



College Algebra Summer Math Packet

Congratulations! You will soon be learning College Algebra!

This summer math packet is a review of some of the concepts learned in your previous course that are needed when you begin your College Algebra course in August. It will assure that all students begin the school year on the same page and with equal opportunity to learn and build upon mathematical concepts that should have been learned in previous courses.

Instructions for completing the packet:

- Please print the packet or use loose leaf paper to complete the packet by hand showing all work. Work must be neat and legible.
- Please use your previous class notes or the websites provided to help you if you need reminders on how to complete some practice problems.
- Take notes as you complete your work. You will be given a quiz on this material the first week of school.
- Work on the packet with your friends. Help each other. Every student is responsible for knowing the material in this packet when you return in August. We will review as a team and everyone will be expected to participate.
- Bring your packet to our first class together. It will be collected for a grade. Only packets done with paper and pencil will be accepted.

Helpful Websites:

<http://www.mathtv.com/>

<http://www.purplemath.com/modules/index.htm>

<https://www.khanacademy.org>

Helpful for graphing functions:

<https://www.education.ti.com/en/resources/family-of-functions>

Name _____

SHORT ANSWER. Write the word or phrase that best completes each statement or answers the question.

Simplify the expression.

1) $22 - [10 - (4 - 7)] + (5 - 7)^3$

1) _____

Find the value of the algebraic expression at the given replacement value.

2) $\frac{y - 3x}{6x + xy}$ when $x = -4, y = 3$

2) _____

Solve the equation.

3) $-3(k - 5) - (-4k - 2) = 4$

3) _____

4) $\frac{x + 4}{6} + \frac{x - 1}{2} = \frac{5}{6}$

4) _____

5) $\frac{1}{4}(x - 12) - \frac{1}{9}(x - 9) = x - 5$

5) _____

6) $1.5x + 2.8 = 0.7x - 0.08$

6) _____

Write the solution set using interval notation.

7) $3(x + 7) \leq 4(x - 8)$

7) _____

8) $\frac{-7x - 20}{4} < 37$

8) _____

9) $\frac{1}{3}(5x - 12) \geq x - 2$

9) _____

10) $\frac{3}{4} + \frac{5}{6} \leq \frac{x}{24}$

10) _____

Solve the compound inequality. Graph the solution set.

11) $17 \leq 4t + 1 \leq 21$

11) _____

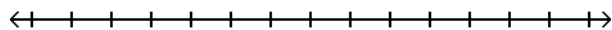

12) $-32 \leq -5z + 3 \leq -17$

12) _____

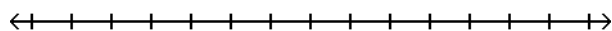

13) $-5x + 1 \geq 11$ or $3x + 3 \geq -9$

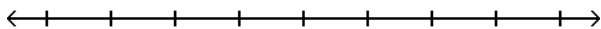

13) _____

Solve the absolute value equation.

14) $|6x + 7| = 9$

14) _____

15) $\left| \frac{9x + 36}{4} \right| = 9$

15) _____

16) $|5x - 7| = |x - 4|$

16) _____

17) $|7x + 2| = |-8 + 8x|$

17) _____

Solve the inequality. Graph the solution set.

18) $|8k + 1| \leq 4$

18) _____

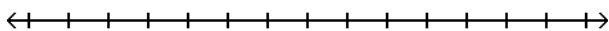

19) $|x - 3| + 6 \geq 11$

19) _____

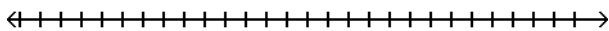

Solve the absolute value equation.

20) $|4x + 6| = 7$

20) _____

21) $|8x + 4| + 8 = 17$

21) _____

22) $\left| \frac{7x - 2}{3} \right| = 4$

22) _____

Graph the equation.

23) $x + y = 6$

23) _____

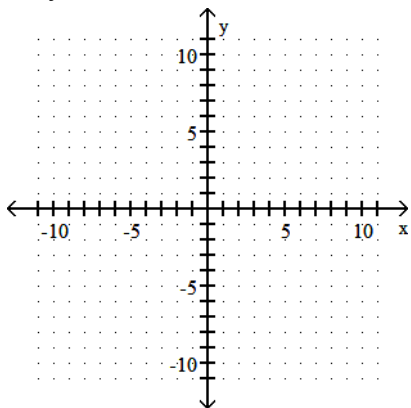

24) $y = \frac{3}{4}x + 8$

24) _____

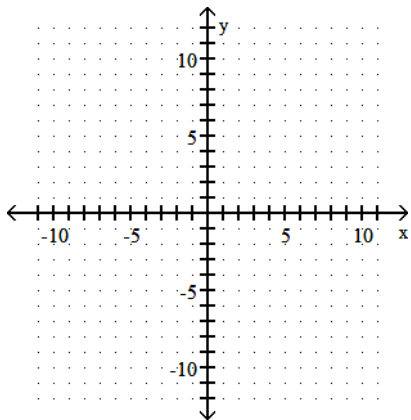

25) $y = |x| - 4$

25) _____

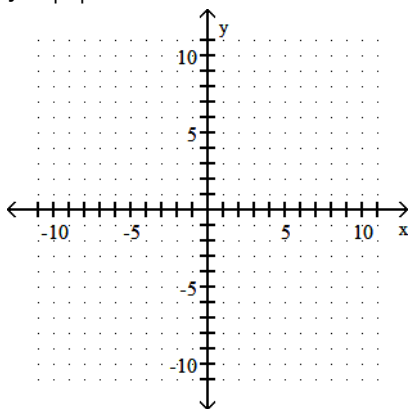

26) $y = x^2 - 2$

26) _____

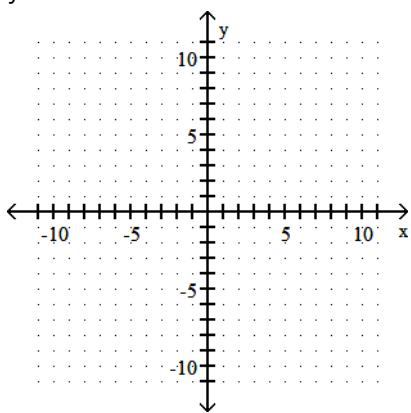

27) $y = |x - 3|$

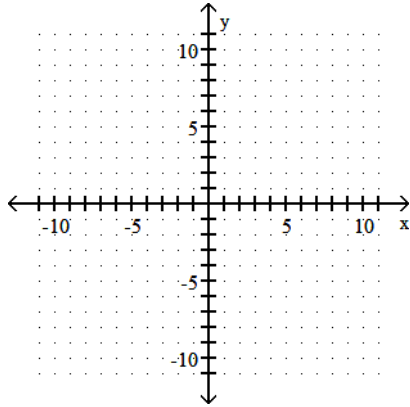

27) _____

28) $y = x^3 - 3$

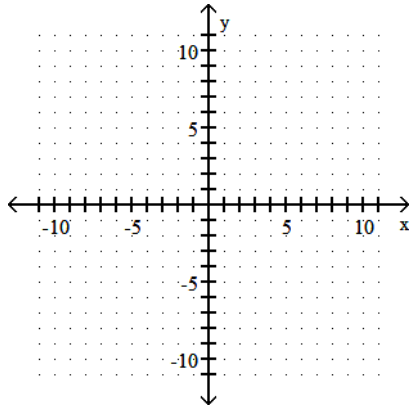

28) _____

Find the domain and the range of the relation. Use the vertical line test to determine whether the graph is the graph of a function.

29)

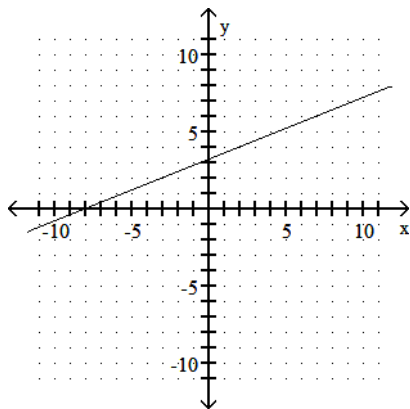

29) _____

30)

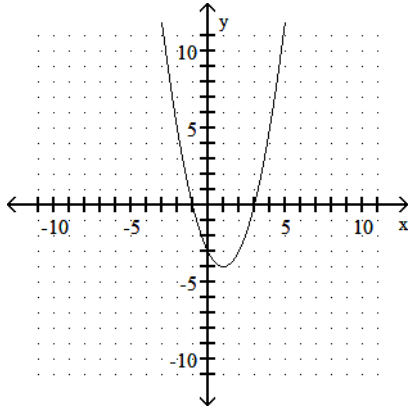

30) _____

31)

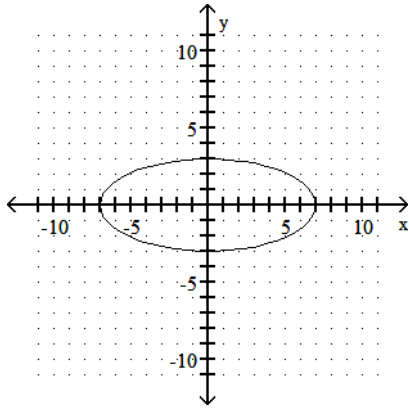

31) _____

Find the indicated value.

32) Find $f(-4)$ when $f(x) = 3x^2 - 5x + 6$.

32) _____

Graph the function.

33) $f(x) = -\frac{2}{3}x + 2$

33) _____

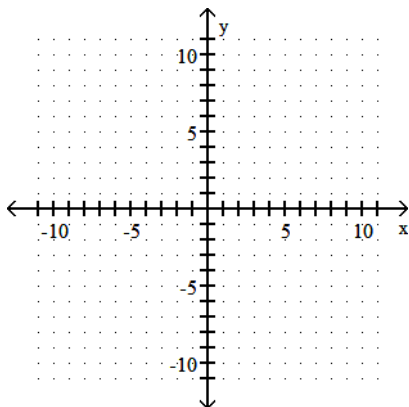

Graph the equation.

34) $x + 3y = 3$

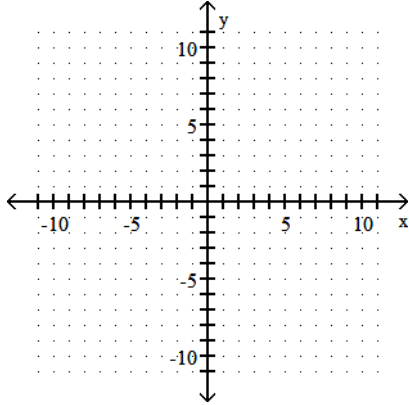

34) _____

35) $-x + 3y = 6$

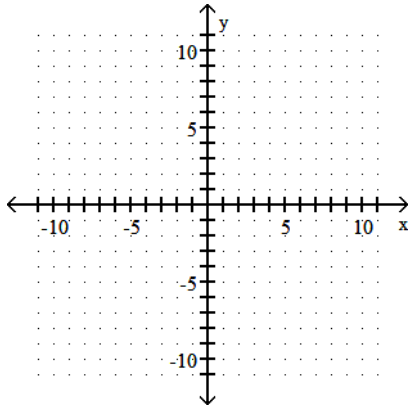

35) _____

36) $-2x + y = 6$

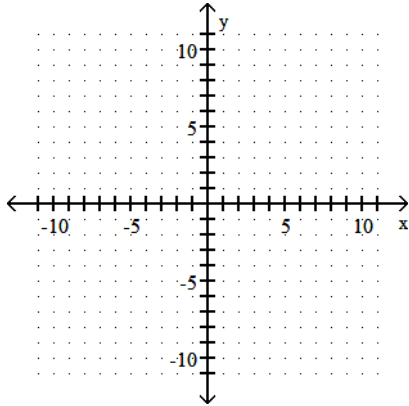

36) _____

Find the slope of the line that goes through the given points.

37) $(-6, -2), (3, -2)$

37) _____

38) $(5, -8), (-4, 5)$

38) _____

39) $(-8, 7), (-8, 6)$

39) _____

Use the points shown on the graph to determine the slope of the line.

40)

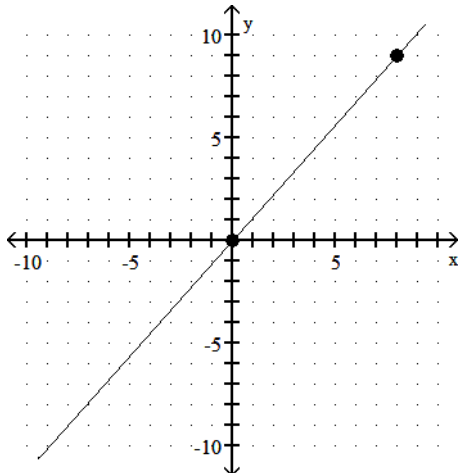

40) _____

41)

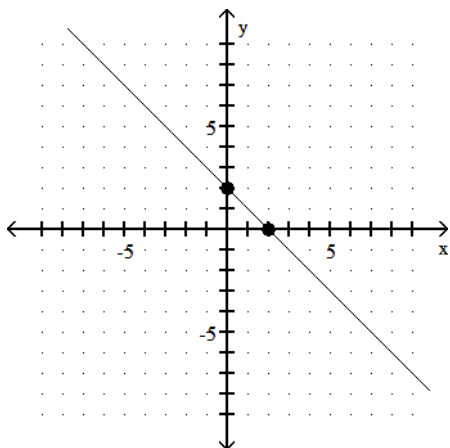

41) _____

Find the slope of the line.

42) $3x + 5y = 28$

42) _____

43) $-2y + 4x = 10$

43) _____

Find the slope and the y-intercept of the line.

44) $3x + 5y = -16$

44) _____

Find the slope of the line.

45) $x + 9 = 5$

45) _____

Determine whether the lines are parallel, perpendicular, or neither.

46) $54x - 9y = 5$

$6x - y = 7$

46) _____

47) $-3x - 6y = 2$

$2x - y = 6$

47) _____

Graph the equation.

48) $y = \frac{3}{4}x + 3$

48) _____

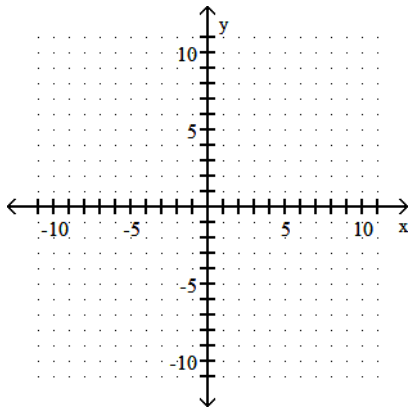

49) $-5x + 7y = 35$

49) _____

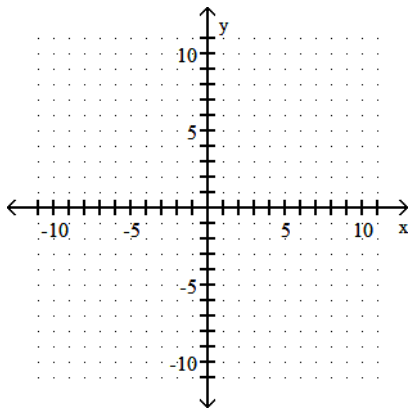

Write an equation of the line with the given slope and containing the given point. Write the equation in the form $y = mx + b$.

50) Slope -4; through $(-2, 5)$

50) _____

Write an equation in standard form for the line graphed.

51)

51) _____

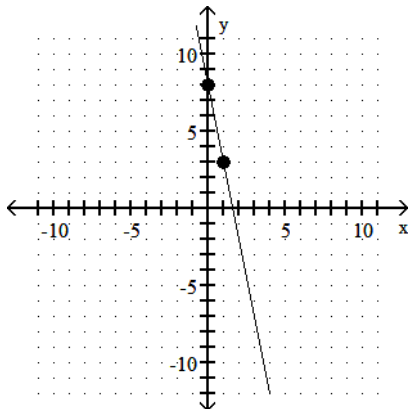

Find an equation of the line. Write the equation using function notation.

52) Through $(1, 8)$ and $(4, 14)$

52) _____

Find an equation of the line. Write the equation in standard form.

53) Slope $-\frac{1}{8}$; y-intercept (0, 8)

53) _____

54) Horizontal; through (3, -9)

54) _____

Find an equation of the line. Write the equation using function notation.

55) Through (3, 5); parallel to $f(x) = 5x - 7$

55) _____

56) Through (-1, 4); perpendicular to $f(x) = 4x - 2$

56) _____

Graph the inequality.

57) $5x + y > -6$

57) _____

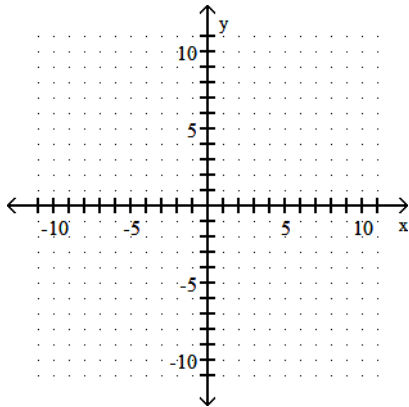

58) $y \leq -9$

58) _____

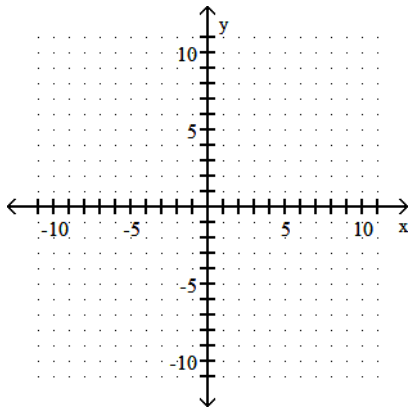

Determine whether the ordered pair is a solution of the system of linear equations.

59) (2, -5), $\begin{cases} x + y = -3 \\ x - y = 7 \end{cases}$

59) _____

Solve the system of equations.

60) $\begin{cases} 2x - 1y = 21 \\ x = -3y \end{cases}$

60) _____

61)
$$\begin{cases} 5x + 2y = 1 \\ 2x + 2y = 16 \end{cases}$$

61) _____

62)
$$\begin{cases} 4x + y = 27 \\ 2x + 4y = 24 \end{cases}$$

62) _____

Graph the solutions to the system of linear inequalities.

63)
$$\begin{cases} y \geq x - 4 \\ y \leq -4 - x \end{cases}$$

63) _____

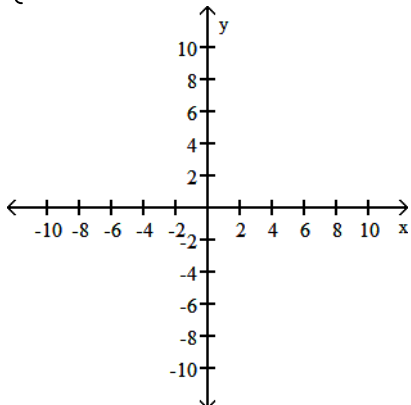

64)
$$\begin{cases} y < -2x - 3 \\ y > x + 3 \end{cases}$$

64) _____

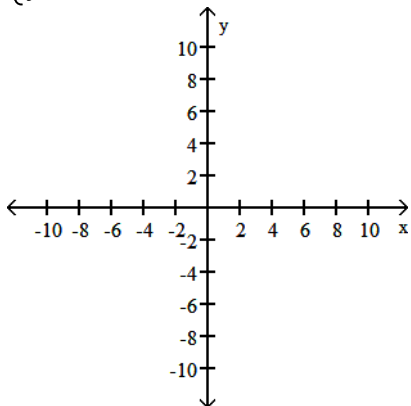

Simplify. Write the answer with positive exponents.

65) $-4x^4y \cdot -6x^5y^3$

65) _____

66) $\frac{x^9y^{12}}{x^4y^5}$

66) _____

67) $\frac{x^{-7}y^{11}}{x^{-2}y^{-2}}$

67) _____

68) $\frac{18x^{-1}y^4}{3xy^{-2}}$

68) _____

Perform the indicated operations.

69) $(7x^8 + 7x^7 + 9x^6 - 4) + (4x^8 + 4x^7 + 4x^6 + 9)$

69) _____

70) $(5x^2 + 6) - (-x^3 + 8x^2 + 10)$

70) _____

71) Subtract $(4x^7 - 16x^6 - 18)$ from $(7x^7 + 15x^6 + 6)$.

71) _____

Multiply.

72) $-9ax^5(-10ax^6 - 12x^2 - 2a)$

72) _____

73) $(x - 1)(4x + 12)$

73) _____

74) $(7x - 3)^2$

74) _____

Factor the polynomial completely.

75) $18x^3 - 6x$

75) _____

76) $x(y - 15) - 7(y - 15)$

76) _____

77) $4x + 36 + xy + 9y$

77) _____

78) $xy + 12x - 10y - 120$

78) _____

79) $x^2 + 7x - 44$

79) _____

80) $4x^2 - 28x + 48$

80) _____

81) $15x^2 + 16x + 4$

81) _____

82) $25x^2 - 9$

82) _____

Solve the equation.

83) $(4x - 3)(x + 1) = 0$

83) _____

84) $x^3 = 81x$

84) _____

85) $4x^2 + 12x + 9 = 0$

85) _____

Find the domain of the rational function.

$$86) f(x) = \frac{8x}{-7 - x}$$

86) _____

$$87) f(x) = \frac{1 - 8x}{x^2 - 18x + 17}$$

87) _____

Simplify the rational expression.

$$88) \frac{5x - 15}{18 - 6x}$$

88) _____

$$89) \frac{7x^2 + 21x^3}{10x + 30x^2}$$

89) _____

Multiply or divide as indicated. Simplify completely.

$$90) \frac{35x + 35}{10x - 5} \cdot \frac{50x - 25}{7x^2 - 7}$$

90) _____

$$91) \frac{x^2 - 24x + 144}{10x - 120} \div \frac{2x - 24}{20}$$

91) _____

Perform the indicated operation. Simplify if possible.

$$92) \frac{x}{x - 3} + \frac{-5}{x - 3}$$

92) _____

$$93) \frac{3}{r} + \frac{7}{r + 3}$$

93) _____

$$94) \frac{b}{b^2 - 25} + \frac{5}{b + 5} - \frac{6}{b}$$

94) _____

Divide.

$$95) \frac{-40x^6 - 56x^5 - 64x^4}{-8x^5}$$

95) _____

$$96) (-10x^3 - 13x^2 - 10x - 3) \div (2x + 1)$$

96) _____

$$97) (36x^3 - 25x) \div (6x - 1)$$

97) _____

Solve the equation.

$$98) \frac{x}{6} + \frac{1}{3} = \frac{x - 4}{3}$$

98) _____

$$99) 1 + \frac{1}{x} = \frac{12}{x^2}$$

99) _____

Find the square root. Assume that all variables represent positive real numbers.

$$100) \sqrt{4x^6}$$

100) _____

Find the cube root.

$$101) \sqrt[3]{-729x^6}$$

101) _____

$$102) \sqrt[3]{-27x^{30}y^{36}}$$

102) _____

Find the root. Assume that all variables represent nonnegative real numbers.

$$103) -\sqrt[4]{256x^{12}y^8}$$

103) _____

104)

$$\sqrt[3]{\frac{216}{x^{24}}}$$

104) _____

Use radical notation to write the expression. Simplify if possible.

$$105) 81^{1/2}$$

105) _____

$$106) 27^{4/3}$$

106) _____

$$107) 7x^{3/4}$$

107) _____

Write with positive exponents. Simplify if possible.

$$108) 8^{-4/3}$$

108) _____

$$109) -64^{-4/3}$$

109) _____

Use the properties of exponents to simplify the expression. Write with positive exponents.

$$110) x^{5/8} \cdot x^{3/8}$$

110) _____

$$111) \frac{x^{4/3} \cdot x^{6/5}}{x^{-1/2}}$$

111) _____

$$112) \frac{y^{3/4}}{y^{1/4}}$$

112) _____

$$113) (b^3)^{2/3}$$

113) _____

Use the product rule to multiply. Assume all variables represent positive real numbers.

114) $\sqrt{32} \cdot \sqrt{50}$

114) _____

115) $\sqrt[3]{5} \cdot \sqrt[3]{25}$

115) _____

Use the quotient rule to divide and simplify.

116) $\sqrt{\frac{3}{16}}$

116) _____

Simplify the radical expression. Assume that all variables represent positive real numbers.

117) $\sqrt{500k^7q^8}$

117) _____

118) $\sqrt[3]{64x^4y^5}$

118) _____

119) $\sqrt[5]{1024x^3y^{22}}$

119) _____

Find the distance between the pair of points.

120) (5, -2) and (3, -6)

120) _____

Find the midpoint of the line segment whose endpoints are given.

121) (3, -8), (-3, 1)

121) _____

Add or subtract. Assume all variables represent positive real numbers.

122) $-5\sqrt{7} - 4\sqrt{63}$

122) _____

123) $-4\sqrt{108} + 4\sqrt{75} - 7\sqrt{243}$

123) _____

Solve.

124) Find the perimeter of the trapezoid. Simplify.

124) _____

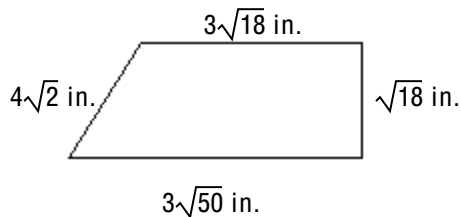

Multiply, and then simplify if possible. Assume all variables represent positive real numbers.

125) $\sqrt{7}(\sqrt{35} + \sqrt{7})$

125) _____

126) $(\sqrt{10} + \sqrt{7})(\sqrt{10} - \sqrt{7})$

126) _____

127) $(\sqrt{5} + \sqrt{7})^2$

127) _____

Solve.

128) $\sqrt{9x - 8} - 8 = 0$

128) _____

129) $\sqrt{x - 2} = 5$

129) _____

Rationalize the denominator and simplify. Assume that all variables represent positive real numbers.

130) $\sqrt{\frac{1}{7}}$

130) _____

131) $\frac{35}{\sqrt{7x}}$

131) _____

132) $\frac{3}{6 - \sqrt{10}}$

132) _____

133) $\frac{\sqrt{6} - \sqrt{7}}{\sqrt{6} + \sqrt{7}}$

133) _____

Rationalize the numerator and simplify. Assume all variables represent positive real numbers.

134) $\frac{3\sqrt{x}}{\sqrt{5y}}$

134) _____

Write in terms of i.

135) $\sqrt{-144}$

135) _____

136) $\sqrt{-270}$

136) _____

Multiply or divide.

137) $\sqrt{-5} \cdot \sqrt{-6}$

137) _____

138) $\frac{\sqrt{-40}}{\sqrt{-5}}$

138) _____

Perform the indicated operation. Write the result in the form $a + bi$.

139) $(3 - 6i) + (7 + 2i)$

139) _____

140) $(6 - 4i) - (6 - i)$

140) _____

141) $4i(9 - 7i)$

141) _____

142) $(8 + 9i)^2$

142) _____

Solve the equation by completing the square.

143) $x^2 - 2x - 3 = 0$

143) _____

$$144) x^2 + 16x + 47 = 0$$

144) _____

Use the quadratic formula to solve the equation.

$$145) x^2 + 10x + 24 = 0$$

145) _____

Use the discriminant to determine the number and type of solutions of the equation.

$$146) x^2 - 6x + 5 = 0$$

146) _____

$$147) x^2 - 12x + 36 = 0$$

147) _____

$$148) x^2 - 3x + 8 = 0$$

148) _____

Write as an exponential equation.

$$149) \log_5 \frac{1}{25} = -2$$

149) _____

$$150) \log_7 \sqrt{7} = \frac{1}{2}$$

150) _____

Write as a logarithmic equation.

$$151) 5^2 = 25$$

151) _____

$$152) 5^{-3} = \frac{1}{125}$$

152) _____

Find the value of the logarithmic expression.

$$153) \log_3 27$$

153) _____

$$154) \log_{1/4} 4$$

154) _____

Simplify.

$$155) \log_7 7^{13}$$

155) _____

$$156) \log_9 9$$

156) _____

Find the value of the logarithmic expression.

$$157) \log_3 \frac{1}{27}$$

157) _____

Solve for x.

$$158) \log_5 25 = x$$

158) _____

$$159) \log_3 x = -2$$

159) _____

Express as the logarithm of a single expression. Assume that variables represent positive numbers.

160) $\log_3 9 + \log_3 7$

160) _____

161) $\log_8 2 + \log_8 (x^3 - 2) + \log_8 4$

161) _____

162) $\log_7 8 - \log_7 10$

162) _____

Use the power property to rewrite the expression.

163) $\log_2 x^8$

163) _____

164) $\log_2 13^{-2}$

164) _____

165) $\log_4 \sqrt[5]{y}$

165) _____

Answer Key

Testname: COLLEGE ALGEBRA

1) 1

2) $-\frac{5}{12}$

3) -13

4) 1

5) $\frac{108}{31}$

6) -3.6

7) $[53, \infty)$

8) $(-24, \infty)$

9) $[3, \infty)$

10) $[38, \infty)$

11) $[4, 5]$

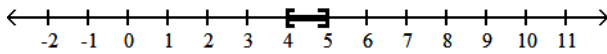

12) $[4, 7]$

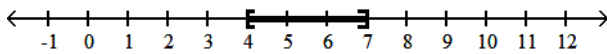

13) $(-\infty, \infty)$

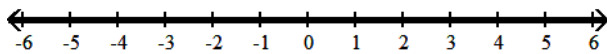

14) $\frac{1}{3}, -\frac{8}{3}$

15) -8, 0

16) $\frac{3}{4}, \frac{11}{6}$

17) $10, \frac{2}{5}$

18) $\left[-\frac{5}{8}, \frac{3}{8}\right]$

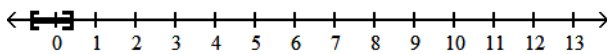

19) $(-\infty, -2] \cup [8, \infty)$

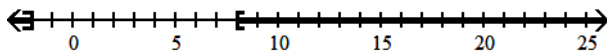

20) $\frac{1}{4}, -\frac{13}{4}$

21) $\frac{5}{8}, -\frac{13}{8}$

22) $2, -\frac{10}{7}$

Answer Key

Testname: COLLEGE ALGEBRA

23)

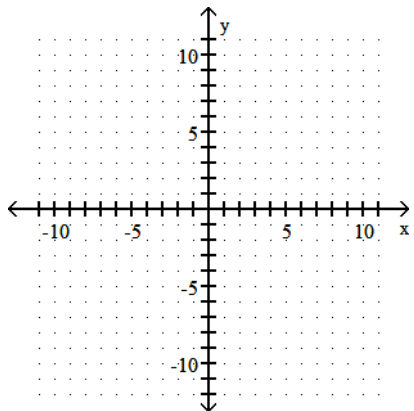

24)

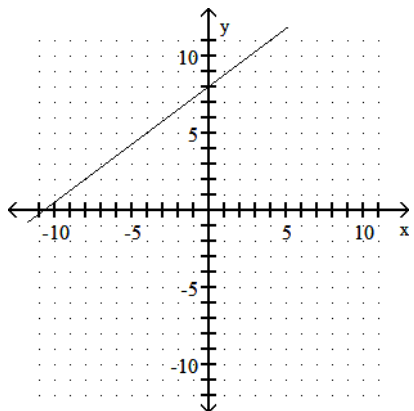

25)

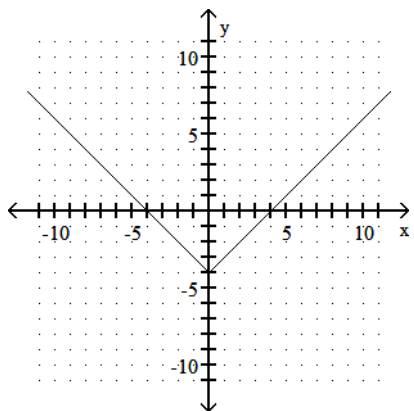

Answer Key

Testname: COLLEGE ALGEBRA

26)

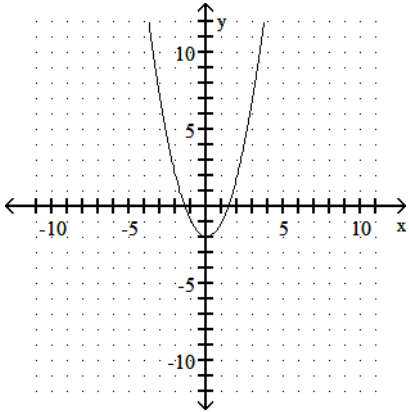

27)

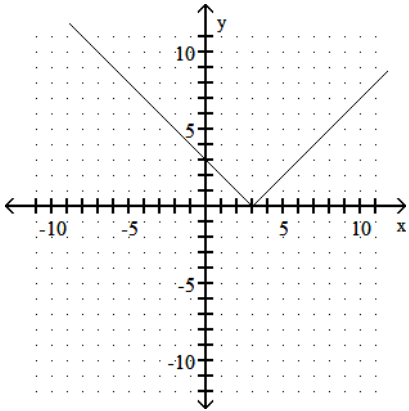

28)

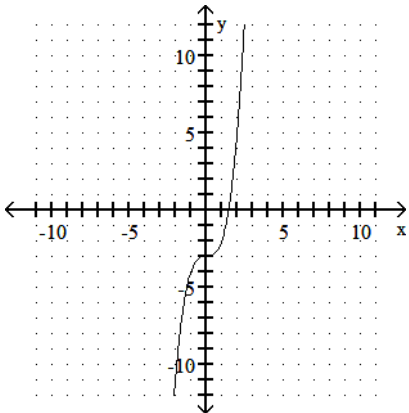

29) domain: $(-\infty, \infty)$

range: $(-\infty, \infty)$

function

30) domain: $(-\infty, \infty)$

range: $[-4, \infty)$

function

31) domain: $[-7, 7]$

range: $[-3, 3]$

not a function

32) 74

Answer Key

Testname: COLLEGE ALGEBRA

33)

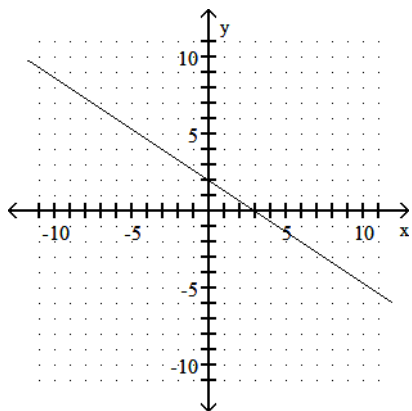

34)

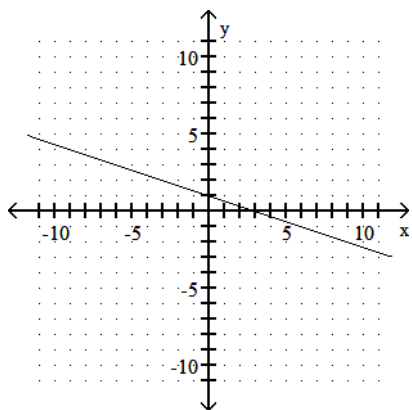

35)

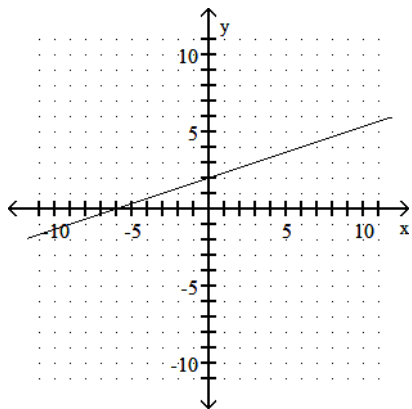

Answer Key

Testname: COLLEGE ALGEBRA

36)

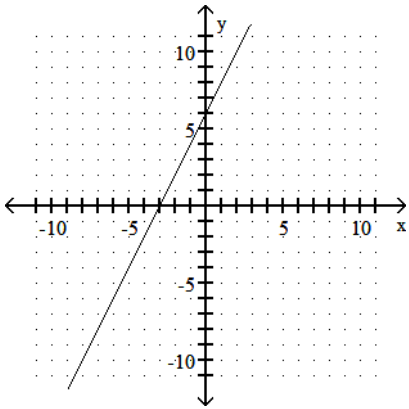

37) 0

38) $-\frac{13}{9}$

39) undefined

40) $\frac{9}{8}$

41) -1

42) $-\frac{3}{5}$

43) 2

44) $m = -\frac{3}{5}$; $b = -\frac{16}{5}$

45) undefined

46) parallel

47) perpendicular

48)

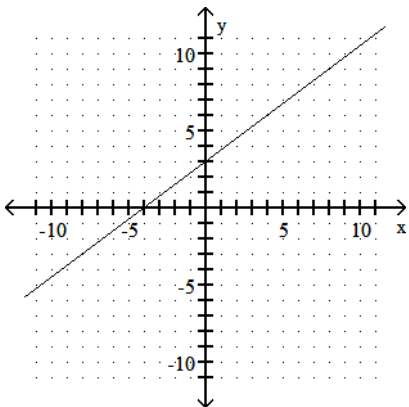

Answer Key

Testname: COLLEGE ALGEBRA

49)

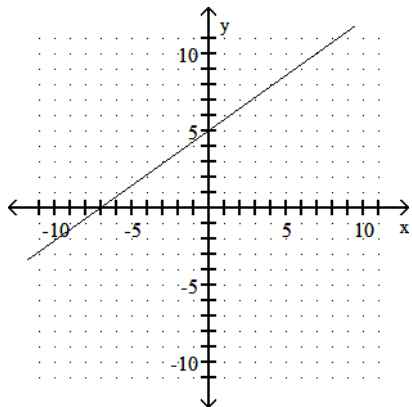

50) $y = -4x - 3$

51) $5x + y = 8$

52) $f(x) = 2x + 6$

53) $x + 8y = 64$

54) $y = -9$

55) $f(x) = 5x - 10$

56) $f(x) = -\frac{1}{4}x + \frac{15}{4}$

57)

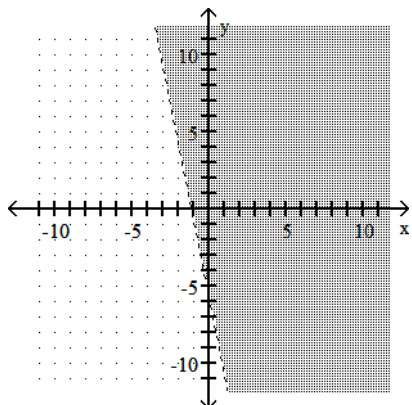

58)

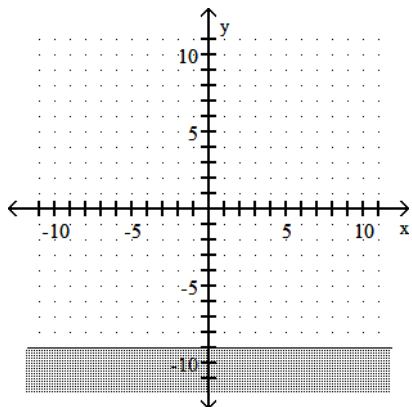

59) Yes

60) (9, -3)

61) (-5, 13)

Answer Key

Testname: COLLEGE ALGEBRA

62) (6, 3)

63)

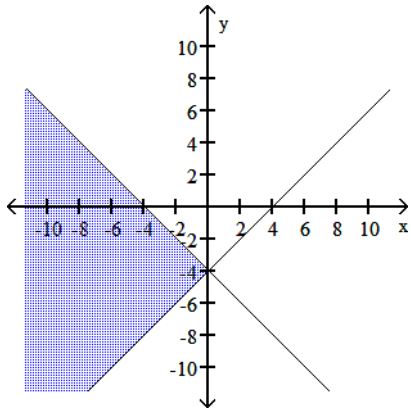

64)

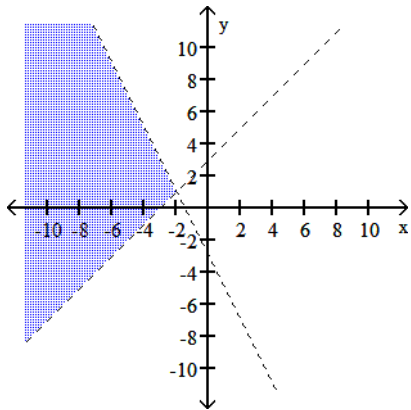

65) $24x^9y^4$

66) x^5y^7

67) $\frac{y^{13}}{x^5}$

68) $\frac{6y^6}{x^2}$

69) $11x^8 + 11x^7 + 13x^6 + 5$

70) $x^3 - 3x^2 - 4$

71) $3x^7 + 31x^6 + 24$

72) $90a^2x^{11} + 108ax^7 + 18a^2x^5$

73) $4x^2 + 8x - 12$

74) $49x^2 - 42x + 9$

75) $6x(3x^2 - 1)$

76) $(y - 15)(x - 7)$

77) $(x + 9)(4 + y)$

78) $(y + 12)(x - 10)$

79) $(x + 11)(x - 4)$

80) $4(x - 3)(x - 4)$

81) $(3x + 2)(5x + 2)$

Answer Key

Testname: COLLEGE ALGEBRA

82) $(5x + 3)(5x - 3)$

83) $\frac{3}{4}, -1$

84) $-9, 0, 9$

85) $-\frac{3}{2}$

86) $\{x \mid x \text{ is a real number and } x \neq -7\}$

87) $\{x \mid x \text{ is a real number and } x \neq 17, x \neq 1\}$

88) $-\frac{5}{6}$

89) $\frac{7x}{10}$

90) $\frac{25}{x - 1}$

91) 1

92) $\frac{x - 5}{x - 3}$

93) $\frac{10r + 9}{r(r + 3)}$

94) $\frac{-25(b - 6)}{b(b + 5)(b - 5)}$

95) $5x + 7 + \frac{8}{x}$

96) $-5x^2 - 4x - 3$

97) $6x^2 + x - 4 - \frac{4}{6x - 1}$

98) 10

99) $-4, 3$

100) $2x^3$

101) $-9x^2$

102) $-3x^{10}y^{12}$

103) $-4x^3y^2$

104) $\frac{6}{x^8}$

105) 9

106) 81

107) $7\sqrt[4]{x^3}$

108) $\frac{1}{16}$

109) $-\frac{1}{256}$

110) x

111) $x^{91/30}$

112) $y^{1/2}$

Answer Key

Testname: COLLEGE ALGEBRA

113) b^2

114) 40

115) 5

116) $\frac{\sqrt{3}}{4}$

117) $10k^3q^4\sqrt{5k}$

118) $4xy\sqrt[3]{xy^2}$

119) $4y^4\sqrt[5]{x^3y^2}$

120) $2\sqrt{5}$ units

121) $\left(0, -\frac{7}{2}\right)$

122) $-17\sqrt{7}$

123) $-67\sqrt{3}$

124) $31\sqrt{2}$ in.

125) $7\sqrt{5} + 7$

126) 3

127) $12 + 2\sqrt{35}$

128) 8

129) 27

130) $\frac{\sqrt{7}}{7}$

131) $\frac{5\sqrt{7x}}{x}$

132) $\frac{18 + 3\sqrt{10}}{26}$

133) $2\sqrt{42} - 13$

134) $\frac{3x}{\sqrt{5xy}}$

135) $12i$

136) $3i\sqrt{30}$

137) $-\sqrt{30}$

138) $2\sqrt{2}$

139) $10 - 4i$

140) $0 - 3i$

141) $28 + 36i$

142) $-17 + 144i$

143) 3, -1

144) $-8 - \sqrt{17}, -8 + \sqrt{17}$

145) -4, -6

146) two real solutions

147) one real solution

148) two complex but not real solutions

149) $5^{-2} = \frac{1}{25}$

Answer Key

Testname: COLLEGE ALGEBRA

$$150) 7^{\frac{1}{2}} = \sqrt{7}$$

$$151) \log_5 25 = 2$$

$$152) \log_5 \frac{1}{125} = -3$$

$$153) 3$$

$$154) -1$$

$$155) 13$$

$$156) 1$$

$$157) -3$$

$$158) 2$$

$$159) \frac{1}{9}$$

$$160) \log_3 63$$

$$161) \log_8 (8x^3 - 16)$$

$$162) \log_7 \frac{4}{5}$$

$$163) 8 \log_2 x$$

$$164) -2 \log_2 13$$

$$165) \frac{1}{5} \log_4 y$$