

## Summer Assignment: 7<sup>th</sup> Grade (Rising 8<sup>th</sup>) Mathematics

Name: \_\_\_\_\_

This summer packet is for students completing the 7<sup>th</sup> grade. **This is a requirement and will be graded at the beginning of the next school year.** You can refer back to Google Classroom for extra support and additional resources. An answer key has been emailed to your parents so you can check your answers. In order for you to receive full credit, use the following checklist:

### Checklist:

Did you read the instructions carefully? \_\_\_\_\_

Have you answered all the questions completely? \_\_\_\_\_

Did you show your work? \_\_\_\_\_

Did you label all units? \_\_\_\_\_

Did you check your work? \_\_\_\_\_

Did you check the spelling of words that are given to you in the packet? \_\_\_\_\_

Did you reread your explanations to yourself to make sure they make sense? \_\_\_\_\_

### Grading:

Criteria	Points Possible	Points Earned
Attention to detail and neatness: name and date written, checklist used, spelling checked, etc.	10	
Thorough completion: all problems complete with work shown	30	
Accuracy	10	
TOTAL	50	

Have a safe and happy summer!

Ms. Kim-Sowers [hkimsowers@aimpa.org](mailto:hkimsowers@aimpa.org)

Mr. Ruth [pruth@aimpa.org](mailto:pruth@aimpa.org)

Ms. Welsh [jwelsh@aimpa.org](mailto:jwelsh@aimpa.org)

Ms. Savage [msavage@aimpa.org](mailto:msavage@aimpa.org)

This is a suggested time-management checklist to help pace yourself over the summer. You can adjust the checklist as you see fit based on your summer schedule.

Month	Date	Specific Lesson	Check when completed
June	6/15 - 6/19	Lesson 1: The Real Number System	
	6/22 - 6/26	Lesson 2: Rational Number Operations	
	6/29 - 7/3	Lesson 3: Algebraic Expressions	
July	7/6 - 7/10	Lesson 4: Algebraic Equations & Inequalities	
	7/13 - 7/17	Lesson 5: Direct & Inverse Proportions	
	7/20 - 7/24	Lesson 6: Angle Properties & Straight Lines	
	7/27 - 7/31	Lesson 7: Circles, Volume, & Surface Area	
August	8/3 - 8/7	Lesson 8: Statistics	
	8/10 - 8/14	Lesson 9: Probability	
	8/17 - 8/21	Lesson 10: Order of Operations	
	8/24 - 8/28	Lesson 11: Mixed Practice (required only for students taking Algebra 1 next year)	

## Resource Pages:

Specific Lesson	Resources
Lesson 1: The Real Number System	<ul style="list-style-type: none"> <li>- <a href="#">Real-Number System</a></li> <li>- <a href="#">Absolute Value</a></li> </ul>
Lesson 2: Rational Number Operations	<ul style="list-style-type: none"> <li>- <a href="#">Adding and Subtracting Integers</a></li> <li>- <a href="#">Multiply and Divide Integers</a></li> </ul>
Lesson 3: Algebraic Expressions	<ul style="list-style-type: none"> <li>- <a href="#">Evaluating Algebraic Expressions</a></li> <li>- <a href="#">Simplifying Algebraic Expressions</a></li> <li>- <a href="#">Factoring Algebraic Expressions</a></li> </ul>
Lesson 4: Algebraic Equations & Inequalities	<ul style="list-style-type: none"> <li>- <a href="#">One Step Addition/Subtraction</a></li> <li>- <a href="#">One Step Division</a></li> <li>- <a href="#">One Step Multiplication</a></li> <li>- <a href="#">One Step Inequalities</a></li> <li>- <a href="#">Two Step Inequalities</a></li> <li>- <a href="#">Equations with Distributive Property</a></li> <li>- <a href="#">Combining Like-Terms</a></li> <li>- <a href="#">Variables on Both Sides</a></li> </ul>
Lesson 5: Direct & Inverse Proportions	<ul style="list-style-type: none"> <li>- <a href="#">Solving Proportions</a></li> <li>- <a href="#">Constant of Proportionality</a></li> <li>- <a href="#">Direct Proportions</a></li> </ul>
Lesson 6: Angle Properties & Straight Lines	<ul style="list-style-type: none"> <li>- <a href="#">Angles Introduction</a></li> <li>- <a href="#">Naming Angles</a></li> <li>- <a href="#">Angle Types</a></li> <li>- <a href="#">Complementary &amp; Supplementary</a></li> <li>- <a href="#">Vertical Angles</a></li> <li>- <a href="#">Angles in Transversals</a></li> </ul>
Lesson 7: Circles, Volume, & Surface Area	<ul style="list-style-type: none"> <li>- <a href="#">Radius, Diameter, Circumference</a></li> <li>- <a href="#">Area of a Circle</a></li> <li>- <a href="#">Volume of Rectangular Prisms</a></li> <li>- <a href="#">Volume of Triangular Prisms</a></li> <li>- <a href="#">Volume of a Cone</a></li> <li>- <a href="#">Volume of a Cylinder</a></li> </ul>
Lesson 8: Statistics	<ul style="list-style-type: none"> <li>- <a href="#">Mean, Median, and Mode</a></li> <li>- <a href="#">Range</a></li> </ul>
Lesson 9: Probability	<ul style="list-style-type: none"> <li>- <a href="#">Introduction to Theoretical Probability</a></li> <li>- <a href="#">Experimental vs. Theoretical</a></li> </ul>
Lesson 10: Order of Operations	<ul style="list-style-type: none"> <li>- <a href="#">Order of Operations</a></li> </ul>

## Lesson 1: The Real Number System

Find the absolute value of the following number:

a.  $|-4|$  \_\_\_\_\_

b.  $|26|$  \_\_\_\_\_

c.  $|-18|$  \_\_\_\_\_

d.  $|-3|$  \_\_\_\_\_

e.  $|-44|$  \_\_\_\_\_

f.  $|65|$  \_\_\_\_\_

g.  $|-99|$  \_\_\_\_\_

h.  $|-6|$  \_\_\_\_\_

i.  $|-128|$  \_\_\_\_\_

j.  $|28|$  \_\_\_\_\_

**Compare. Use  $<$ ,  $>$ , or  $=$ .**

k.  $|-4|$  \_\_\_\_\_  $|-5|$

l.  $17$  \_\_\_\_\_  $|-17|$

m.  $|29|$  \_\_\_\_\_  $|-29|$

n.  $58$  \_\_\_\_\_  $|-59|$

o.  $30$  \_\_\_\_\_  $|-28|$

p.  $|-7|$  \_\_\_\_\_  $0$

q.  $|86|$  \_\_\_\_\_  $|-68|$

r.  $|14|$  \_\_\_\_\_  $-14$

s.  $|-156|$  \_\_\_\_\_  $|-165|$

t.  $|3|$  \_\_\_\_\_  $|-3|$

Locate the following rational numbers on the number line:

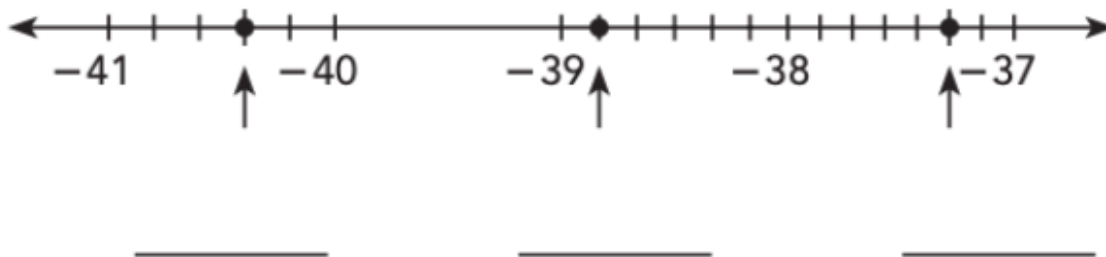

Which of the following numbers are irrational?

- a. 13.4575356...      b. 4.32323      c. -5      d. 17.6

Which of the following numbers is a repeating decimal?

- a. 9.42      b. -13      c. -19.232323...      d. 0.4

Find the square root of the following numbers. Round your answer to the nearest tenths place.

$\sqrt{49} =$  \_\_\_\_\_       $\sqrt{59} =$  \_\_\_\_\_       $\sqrt{121} =$  \_\_\_\_\_       $\sqrt{21} =$  \_\_\_\_\_

Use a calculator and represent each number below as a decimal and order from least to greatest:

$\sqrt{61}$      $\frac{47}{6}$     2.1 = \_\_\_\_\_

Categorize the following numbers:

Number	Terminating Decimal	Repeating Decimal	Non- terminating Decimal	Rational	Irrational
$\sqrt{50}$					
$\frac{13}{20}$					
2.3					
$2.\bar{3}$					

Plot the following rational and irrational numbers on the number line. Convert the numbers to a decimal to help simplify the number.

$\frac{19}{5}$      $\sqrt{25}$      $\sqrt{17}$      $\frac{9}{4}$



## Lesson 2: Rational Number Operations

Write an integer that represents each scenario:

60 meters below the surface: \_\_\_\_\_ Deposit of \$30 into your bank account: \_\_\_\_\_

Withdrawal from your bank account of \$20: \_\_\_\_\_ 45 feet below sea level: \_\_\_\_\_

Altitude of 1,200 feet: \_\_\_\_\_ Weight loss of 15 pounds: \_\_\_\_\_

Stock increased by 4.1%: \_\_\_\_\_ A loss of 30 yards on a play: \_\_\_\_\_

Order the following integers from least to greatest.

7, -3, 4, 12, -10, -2: \_\_\_\_\_

-3, 13, 2, 0, -15, 6: \_\_\_\_\_

-44, 35, -73, -42, -55: \_\_\_\_\_

Order the following integers from greatest to least.

2, -5, 6, -9, 11, -12: \_\_\_\_\_

-10, -14, 3, 0, -7, 5: \_\_\_\_\_

-65, -34, -27, 12, 57, -98: \_\_\_\_\_

Compare the pairs of integers using  $<$ ,  $>$ , or  $=$

-19 \_\_\_\_\_ -11

6 \_\_\_\_\_ -6

-15 \_\_\_\_\_ -11

0 \_\_\_\_\_ -9

3 \_\_\_\_\_ 5

-4 \_\_\_\_\_ -2

9 \_\_\_\_\_ -1

-8 \_\_\_\_\_ -8

Add or subtract the integers.

Use a number line if needed. **NO CALCULATORS FOR THIS PAGE.**

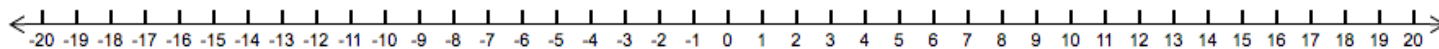

1)  $1 + 15 =$  \_\_\_\_\_

2)  $(-6) - (-17) =$  \_\_\_\_\_

3)  $19 - (-2) =$  \_\_\_\_\_

4)  $(-13) + 20 =$  \_\_\_\_\_

5)  $(-4) + (-18) =$  \_\_\_\_\_

6)  $5 - 14 =$  \_\_\_\_\_

7)  $(-12) - 7 =$  \_\_\_\_\_

8)  $10 + (-16) =$  \_\_\_\_\_

9)  $3 + (-20) =$  \_\_\_\_\_

10)  $(-8) - 12 =$  \_\_\_\_\_

11)  $(-15) - (-10) =$  \_\_\_\_\_

12)  $(-19) + 18 =$  \_\_\_\_\_

13)  $17 + 13 =$  \_\_\_\_\_

14)  $11 - (-9) =$  \_\_\_\_\_

15)  $16 - 0 =$  \_\_\_\_\_

16)  $(-7) + (-14) =$  \_\_\_\_\_

Multiply or divide the integers. **NO CALCULATORS FOR THIS PAGE.**

You may use a multiplication chart if needed.

1)  $6 \times (-4) =$  \_\_\_\_\_

2)  $(-105) \div 7 =$  \_\_\_\_\_

3)  $117 \div 13 =$  \_\_\_\_\_

4)  $(-2) \times (-10) =$  \_\_\_\_\_

5)  $(-11) \times 5 =$  \_\_\_\_\_

6)  $108 \div (-9) =$  \_\_\_\_\_

7)  $(-154) \div (-14) =$  \_\_\_\_\_

8)  $13 \times 12 =$  \_\_\_\_\_

9)  $8 \times 3 =$  \_\_\_\_\_

10)  $(-48) \div (-6) =$  \_\_\_\_\_

11)  $(-40) \div 10 =$  \_\_\_\_\_

12)  $4 \times (-15) =$  \_\_\_\_\_

13)  $(-12) \times (-7) =$  \_\_\_\_\_

14)  $35 \div 5 =$  \_\_\_\_\_

15)  $90 \div (-15) =$  \_\_\_\_\_

16)  $(-1) \times 1 =$  \_\_\_\_\_

### Lesson 3: Algebraic Expressions

Evaluate the following expressions for  $x = 6$ .

1.  $7x$

\_\_\_\_\_

2.  $\frac{x}{3}$

\_\_\_\_\_

3.  $29 - x$

\_\_\_\_\_

4.  $\frac{36}{x}$

\_\_\_\_\_

5.  $9x$

\_\_\_\_\_

6.  $x + 41$

\_\_\_\_\_

7.  $3x + x$

\_\_\_\_\_

8.  $2x - 2$

\_\_\_\_\_

Evaluate the following expressions for  $b = 2$  and  $c = 7$ .

9.  $5 + b + c$

\_\_\_\_\_

10.  $16 + b - c$

\_\_\_\_\_

11.  $c - b + 1$

\_\_\_\_\_

12.  $9b - c$

\_\_\_\_\_

13.  $7c - b$

\_\_\_\_\_

14.  $4c + b$

\_\_\_\_\_

15.  $12b + c$

\_\_\_\_\_

16.  $22 + b - c$

\_\_\_\_\_

Evaluate the following expressions for  $y = 8$  and  $d = 4$ .

17.  $\frac{6y}{d}$

\_\_\_\_\_

18.  $\frac{20}{d} + y$

\_\_\_\_\_

19.  $\frac{yd}{2}$

\_\_\_\_\_

20.  $\frac{y}{d} + 6$

\_\_\_\_\_

Simplify the following expressions:

1)  $10x - 8x + 2 + 10$

2)  $3a + 7 + 2(3 + a)$

3)  $3(m - 5) + m$

4)  $2s + 10 - 7s - 8 + 3s - 7$

5)  $8c - 4 - 2c + 5$

6)  $-4 + 7z + 3 - 2z$

7)  $15 + 4(5y - 10)$

8)  $2d + 17 - 3 - 2d + 4d$

9)  $12n - 8 - 2n + 10 - 4$

10)  $8(2k + 1 + 3k)$

11)  $4(2b + 2) - 3$

12)  $-4 + 8p - 6p - 5 + 20p$

---

Factor the following algebraic expressions:

1)  $6x + 9$

2)  $-20y - 5z$

3)  $15 - 3a$

4)  $2m + 2$

5)  $39u - 52v + 13$

6)  $10z - 60$

7)  $44p + 11q$

8)  $42 + 35w$

9)  $81n - 36$

10)  $40b - 80c - 40d$

## Lesson 4: Algebraic Equations & Inequalities

Solve each equation or inequality by showing your work in order to receive full credit. Use a calculator to check all computational procedures. Be sure to circle your answers.

$$x + 8 = 10$$

---

---

$$20 = y - 10$$

---

---

$$8x = 40$$

---

---

$$v \div 3 = 12$$

---

---

$$w - 8 = 30$$

---

---

$$k + 5 = -65$$

---

---

$$27 = -9x$$

---

---

$$x \div -5 = 5$$

---

---

$$-32 = y + 3$$

---

---

$$-4 = x - 6$$

---

---

$$\frac{x}{3} + 5 = 12$$

---

---

---

$$\frac{y}{4} - 4 = 5$$

---

---

---

$$2w + 6 = 24$$

---

---

---

$$30 = 3y + 9$$

---

---

---

$$\frac{x}{-3} + 9 = 2$$

---

---

---

$$5x + 3 = 2x - 18$$

---

---

---

$$10(2x + 3) = 130$$

---

---

---

$$3(5x - 7) = 9$$

---

---

---

$$\frac{x + 5}{3} = 8$$

---

---

---

$$10x + 4 + 2x = 40$$

---

---

---

$$17x - 10x + 9 = 30$$

$$8x + 3 = 6x + 21$$

---

---

---

---

---

---

Solve and graph the one and two step inequalities.

$<$	$\leq$	$>$	$\geq$
Open dot	Closed dot	Open dot	Closed dot

$$x + 5 < -3$$

$$y - 1 \geq 3$$

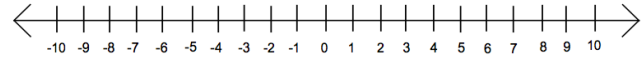
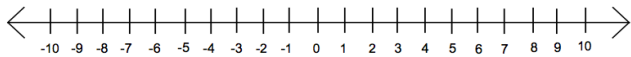

$$4w \leq 16$$

$$c \div 2 > -1$$

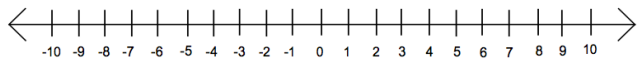
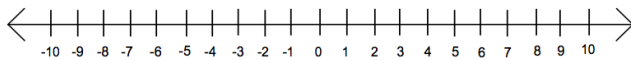

$$k + 2 < -5$$

$$\frac{y}{5} > -2$$

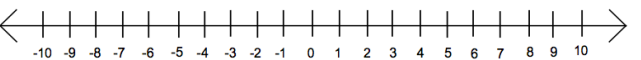
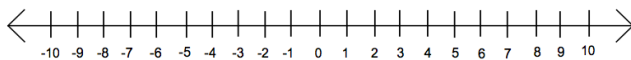

$$2x + 5 > 15$$

---

---

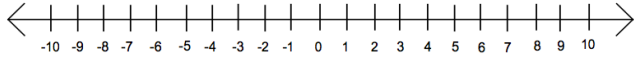

$$\frac{y}{1} - 4 > -1$$

---

---

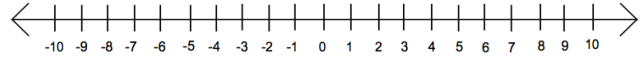

$$4x - 4 > -8$$

---

---



$$\frac{m}{6} - 9 < -9$$

---

---

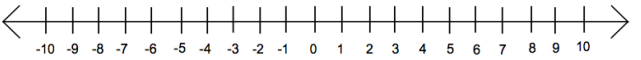

$$3x + 1 \leq 10$$

---

---

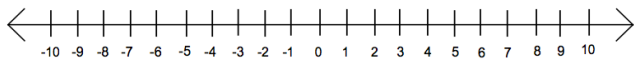

$$\frac{y}{2} + 1 > 3$$

---

---

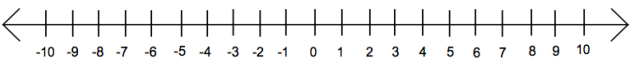

## Lesson 5: Direct & Inverse Proportions

Find the value of  $x$  that will make each proportion true. Show your work to support your answer.

$$\frac{3}{4} = \frac{24}{x}$$

$$\frac{2}{5} = \frac{18}{x}$$

$$\frac{2}{7} = \frac{x}{56}$$

$$\frac{2}{9} = \frac{x}{51}$$

$$\frac{5}{x} = \frac{18}{30}$$

$$\frac{2}{x} = \frac{6}{5}$$

$$\frac{27}{6} = \frac{35}{x}$$

$$\frac{1}{9} = \frac{17}{x}$$

$$\frac{1.7}{4} = \frac{4.2}{x}$$

$$\frac{x}{2.3} = \frac{12.4}{9}$$

Is  $y$  directly proportional to  $x$ ? If yes, state the constant of proportionality ( $\frac{y}{x}$ ) and write the direct proportion equation in the form of  $y=kx$ .

<b>x</b>	1	2	3
<b>y</b>	4	8	12

Is  $y$  directly proportional to  $x$ ? \_\_\_\_\_

Constant of proportionality: \_\_\_\_\_

Equation: \_\_\_\_\_

<b>x</b>	3	6	9
<b>y</b>	10	30	70

Is  $y$  directly proportional to  $x$ ? \_\_\_\_\_

Constant of proportionality: \_\_\_\_\_

Equation: \_\_\_\_\_

<b>x</b>	3	6	9
<b>y</b>	10	30	70

Is  $y$  directly proportional to  $x$ ? \_\_\_\_\_

Constant of proportionality: \_\_\_\_\_

Equation: \_\_\_\_\_

<b>x</b>	2	4	6
<b>y</b>	40	80	120

Is  $y$  directly proportional to  $x$ ? \_\_\_\_\_

Constant of proportionality: \_\_\_\_\_

Equation: \_\_\_\_\_

The table shows the relationship between distance in kilometers and distance in miles. The distance in kilometers is directly proportional to the distance in miles.

<b>Distance (x miles)</b>	20	30	50
<b>Distance (y kilometers)</b>	32.2	48.3	80.5

a) Find the constant of proportionality. What does this value represent in this situation?

b) Write the direct proportion equation.

c) How many kilometers are there in 70 miles?

Tell whether each graph represents a direct proportion. If so, find the constant of proportionality.

1.

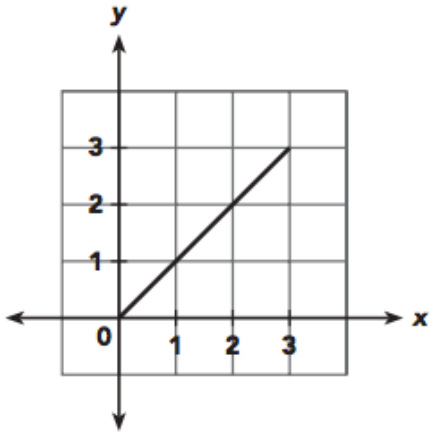

\_\_\_\_\_

2.

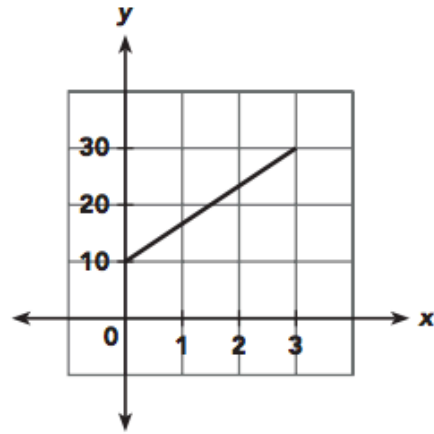

\_\_\_\_\_

3.

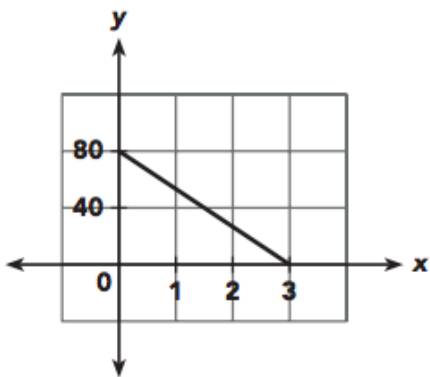

\_\_\_\_\_

4.

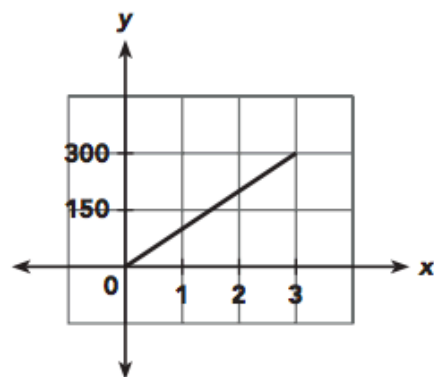

\_\_\_\_\_

The amount of money Joe earns is directly proportional to the number of hours he works. The graph shows the amount of money,  $w$  dollars, Joe earns in  $t$  hours.

a) Find the constant of proportionality. What does this value represent in this situation?

b) How much does Joe earn if he works 3 hours?

c) How long does Joe work if he earns \$90?

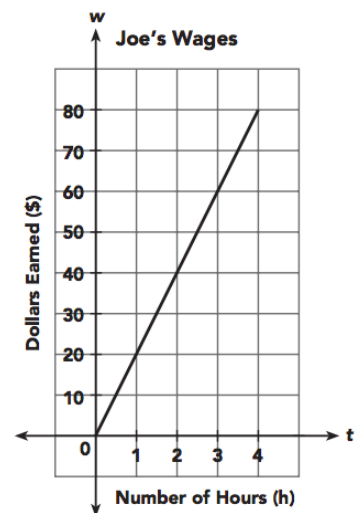

## Lesson 6: Angle Properties and Straight Lines

Calculate the measure of the missing angle.

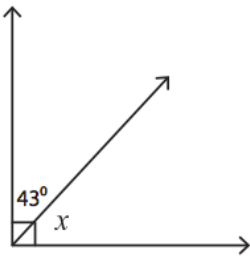

$x =$  \_\_\_\_\_

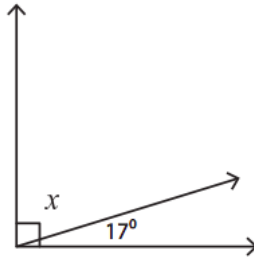

$x =$  \_\_\_\_\_

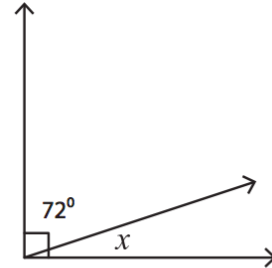

$x =$  \_\_\_\_\_

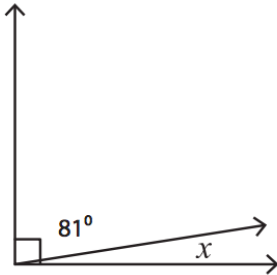

$x =$  \_\_\_\_\_

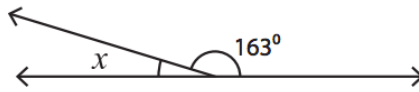

$x =$  \_\_\_\_\_

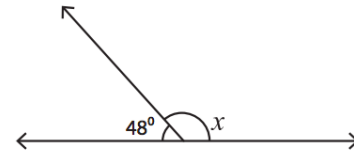

$x =$  \_\_\_\_\_

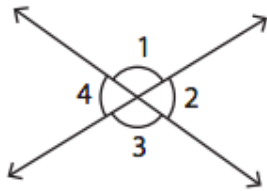

$m\angle 1 = 113^\circ$  ,  $m\angle 2 =$  \_\_\_\_\_

$m\angle 3 =$  \_\_\_\_\_ ,  $m\angle 4 =$  \_\_\_\_\_

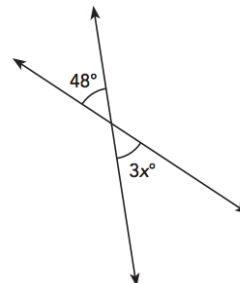
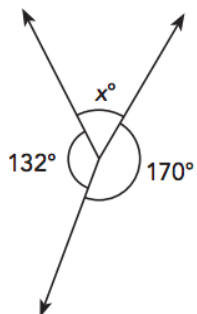
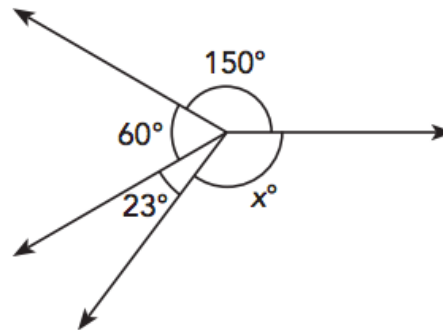

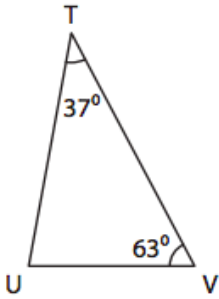

$m\angle U = \underline{\hspace{2cm}}$

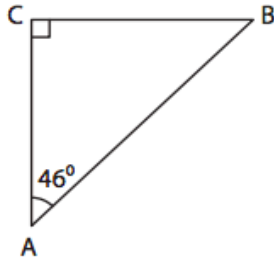

$m\angle B = \underline{\hspace{2cm}}$

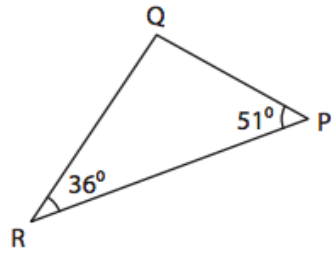

$m\angle Q = \underline{\hspace{2cm}}$

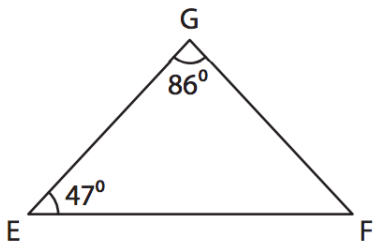

$m\angle F = \underline{\hspace{2cm}}$

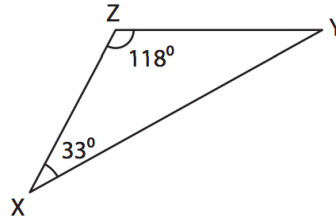

$m\angle Y = \underline{\hspace{2cm}}$

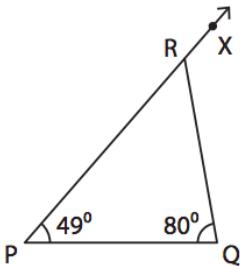

$m\angle QRX = \underline{\hspace{2cm}}$

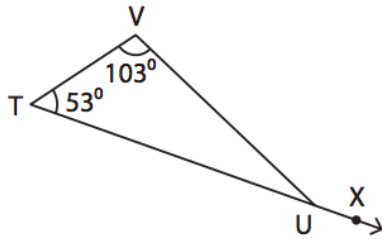

$m\angle VUX = \underline{\hspace{2cm}}$

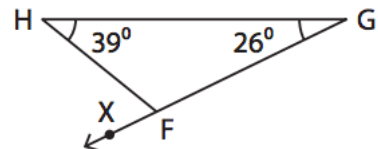

$m\angle HFX = \underline{\hspace{2cm}}$

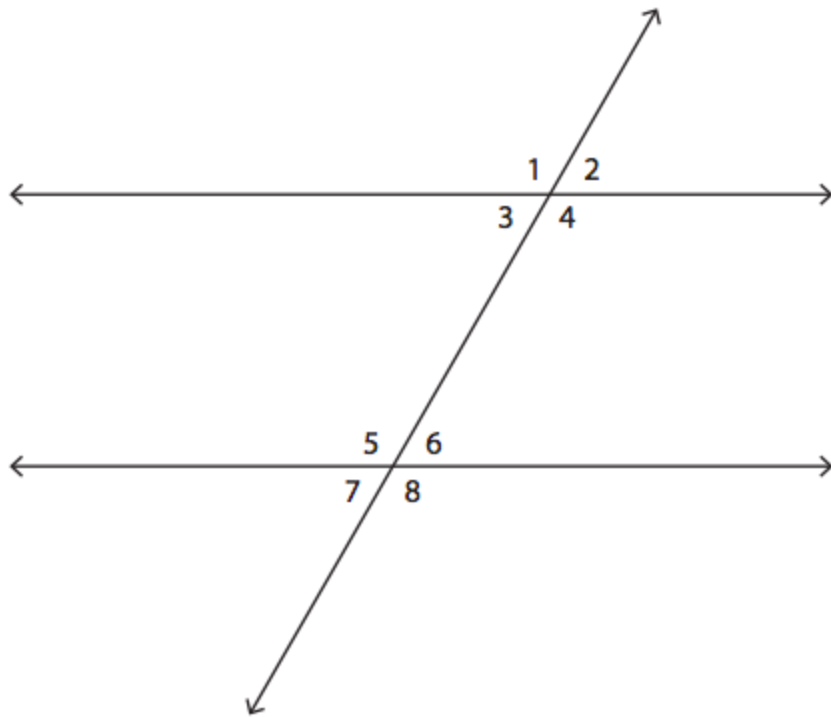

List all of the interior angles: \_\_\_\_\_

List all of the exterior angles: \_\_\_\_\_

List all the pairs of alternate interior angles: \_\_\_\_\_

\_\_\_\_\_

List all the pairs of alternate exterior angles: \_\_\_\_\_

\_\_\_\_\_

List 3 pairs of corresponding angles: \_\_\_\_\_

\_\_\_\_\_

\_\_\_\_\_

Find the value of  $x$  in each set of angles:

1)

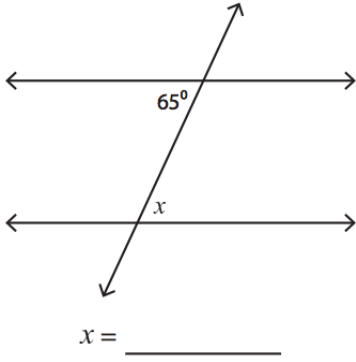

2)

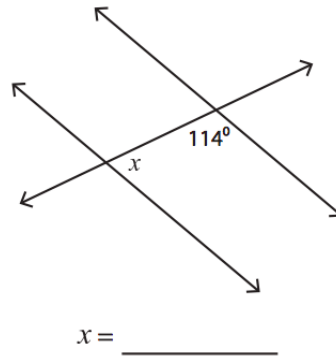

3)

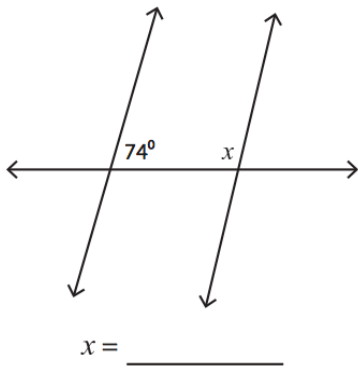

4)

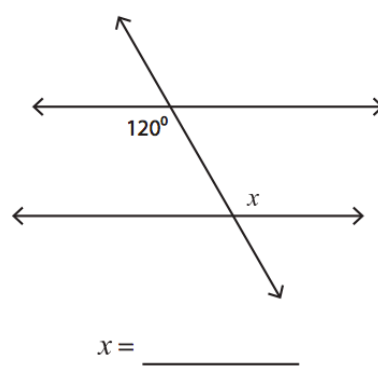

5)

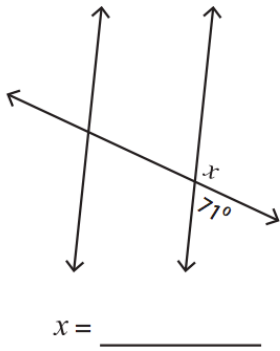

6)

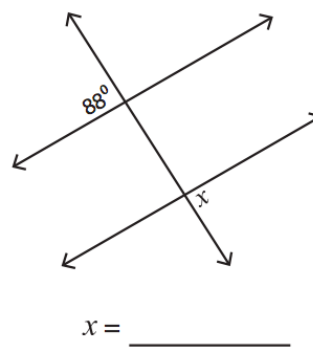

7)

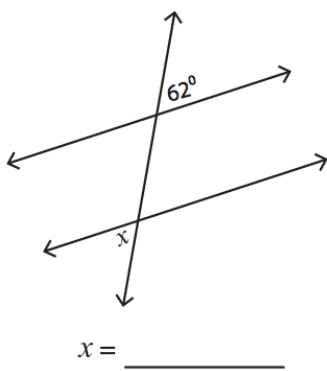

8)

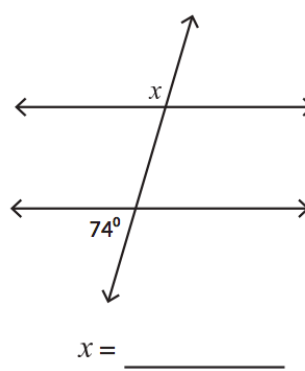

## Lesson 7: Circles, Volume & Surface Areas

Calculate the area and circumference of the following circles. Show work.  
Use 3.14 for  $\pi$ .

$$\text{Circumference} = \pi d \qquad \text{Area} = \pi r^2$$

1)

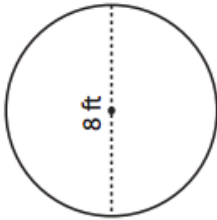

Area = \_\_\_\_\_

Circumference = \_\_\_\_\_

2)

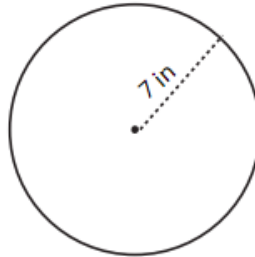

Area = \_\_\_\_\_

Circumference = \_\_\_\_\_

3)

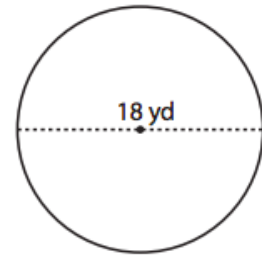

Area = \_\_\_\_\_

Circumference = \_\_\_\_\_

4)

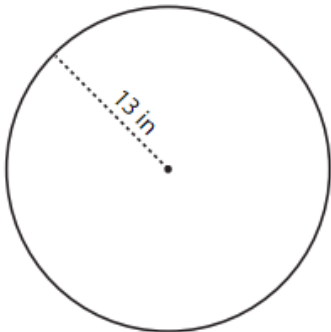

Area = \_\_\_\_\_

Circumference = \_\_\_\_\_

5)

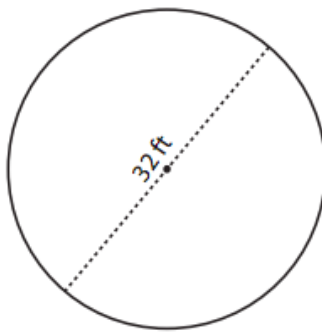

Area = \_\_\_\_\_

Circumference = \_\_\_\_\_

6)

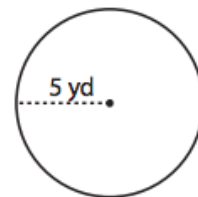

Area = \_\_\_\_\_

Circumference = \_\_\_\_\_

7)

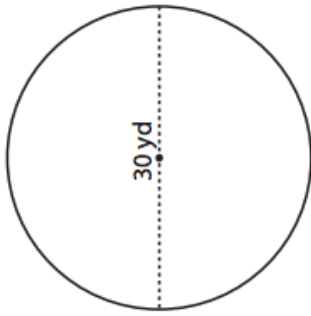

Area = \_\_\_\_\_  
 Circumference = \_\_\_\_\_

8)

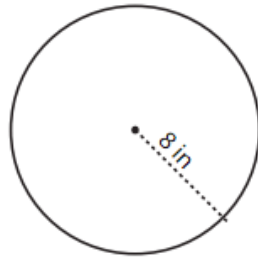

Area = \_\_\_\_\_  
 Circumference = \_\_\_\_\_

9)

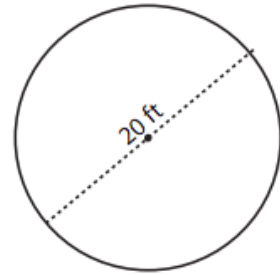

Area = \_\_\_\_\_  
 Circumference = \_\_\_\_\_

The radius of Venus is 3,760.4 miles. Find the following information:



Diameter: \_\_\_\_\_

Circumference: \_\_\_\_\_

The diameter of Saturn is 72,367 miles. Find the following information:

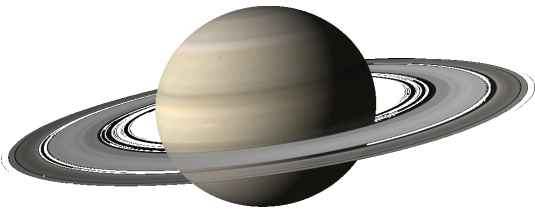

Radius: \_\_\_\_\_

Circumference: \_\_\_\_\_

## Formulas

Rectangular Prism:

$$V = l \times w \times h$$

Triangular Prism:

$$V = \frac{l \times w \times h}{2}$$

Pyramid:

$$V = \frac{l \times w \times h}{3}$$

Cylinder:

$$V = \pi r^2 \times h$$

Cone:

$$V = \frac{\pi r^2 \times h}{3}$$

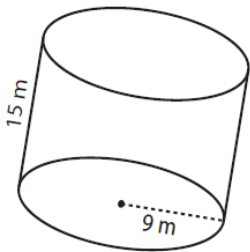

Volume = \_\_\_\_\_

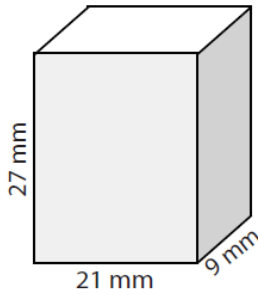

Volume = \_\_\_\_\_

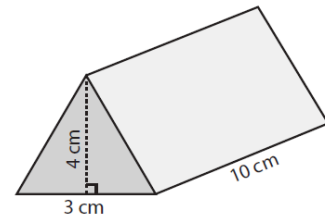

Volume = \_\_\_\_\_

Workspace:

Workspace:

Workspace:

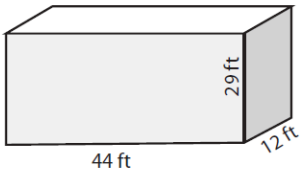

Volume = \_\_\_\_\_

Workspace:

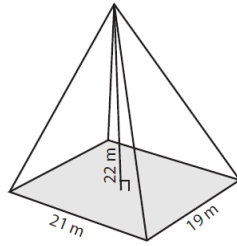

Volume = \_\_\_\_\_

Workspace:

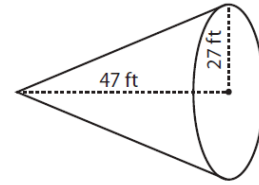

Volume = \_\_\_\_\_

Workspace:

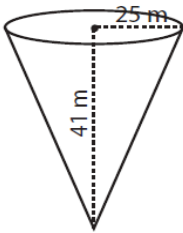

Volume = \_\_\_\_\_

Workspace:

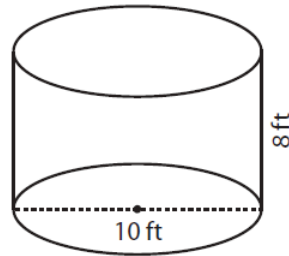

Volume = \_\_\_\_\_

Workspace:

## Lesson 8: Statistics

**Mean** - Finding the mean is the same as finding the \_\_\_\_\_. In order to find the mean, \_\_\_\_\_ up all of the numbers in the data set and then divide it by the amount of numbers in the data set.

**Median** - In order to find the median, you must rewrite the numbers from \_\_\_\_\_ to \_\_\_\_\_. Then, find the middle number in the data set. If there are two numbers in the middle, find the average of the two numbers.

**Mode** - The mode is the \_\_\_\_\_ occurring number in the data set. If there are no numbers that occur the most, you can write, "none".

**Range** - To find the range, take the \_\_\_\_\_ number and subtract the \_\_\_\_\_ number.

### Word Bank:

most      add      greatest      biggest      smallest      average      least

Find the measures of central tendency. Be sure to order your data from least to greatest.

1) 24, 31, 12, 38, 12, 15

2) 5, 28, 16, 32, 5, 16, 48, 29, 5, 35

Mean : \_\_\_\_\_ Median : \_\_\_\_\_

Mean : \_\_\_\_\_ Median : \_\_\_\_\_

Mode : \_\_\_\_\_ Range : \_\_\_\_\_

Mode : \_\_\_\_\_ Range : \_\_\_\_\_

3) 53, 13, 34, 41, 26, 61, 34, 13, 69

4) 85, 58, 72, 85, 46, 93

Mean : \_\_\_\_\_ Median : \_\_\_\_\_

Mean : \_\_\_\_\_ Median : \_\_\_\_\_

Mode : \_\_\_\_\_ Range : \_\_\_\_\_

Mode : \_\_\_\_\_ Range : \_\_\_\_\_

Nine conical flasks have sodium chloride solution of different quantities. The amount of solution (ml) in each flask is given below.

2, 10, 16, 2, 20, 18, 22, 14, 9

Mean : \_\_\_\_\_ Median : \_\_\_\_\_ Mode : \_\_\_\_\_ Range : \_\_\_\_\_

Order data: \_\_\_\_\_

Ten students from a class participated in a math quiz. The scores obtained by them were recorded as follows.

11, 6, 7, 13, 1, 13, 16, 7, 13, 16

Mean : \_\_\_\_\_ Median : \_\_\_\_\_ Mode : \_\_\_\_\_ Range : \_\_\_\_\_

Order data: \_\_\_\_\_

Ray's music album had 15 rock songs, 8 karaokes, 12 hip hops, 10 pop songs, 15 lullabies, 13 jingles and 17 rap songs.

Mean : \_\_\_\_\_ Median : \_\_\_\_\_ Mode : \_\_\_\_\_ Range : \_\_\_\_\_

Order data: \_\_\_\_\_

## Lesson 9: Probability

The marbles pictured below are gray, white, and black. They are placed in a bag and one is drawn at random.

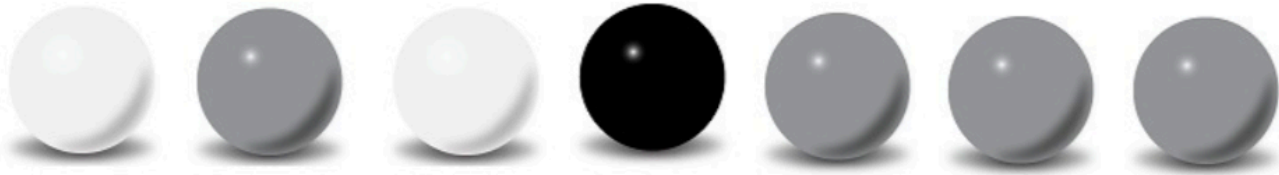

1. Which color marble is least likely to be drawn from the bag? \_\_\_\_\_
2. What is the probability of drawing the black marble from the bag? \_\_\_\_\_
3. What is the probability of drawing a gray marble? \_\_\_\_\_
4. What is the probability of the drawing a white marble? \_\_\_\_\_
5. What is the probability of drawing a marble that is not white? \_\_\_\_\_
6. Would you be more likely to draw a marble that is not black or a marble that is not gray?  
Explain your answer.  
\_\_\_\_\_  
\_\_\_\_\_  
\_\_\_\_\_
7. If three more black marbles were added to the bag,  
what would be the probability of drawing a black marble? \_\_\_\_\_

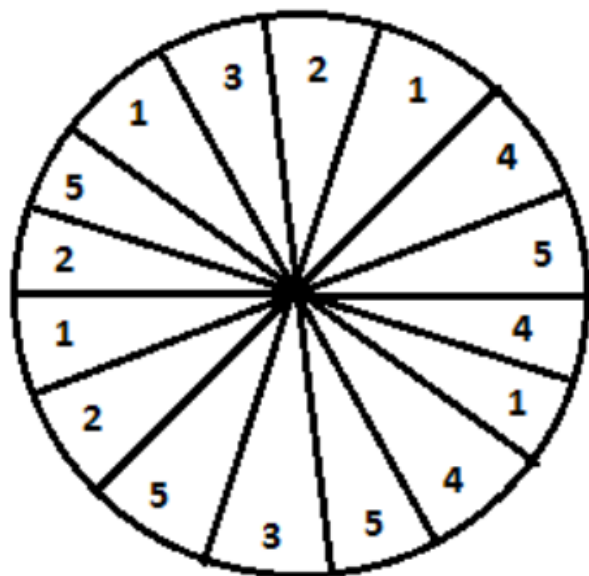

Work Space

<p>What is the probability of choosing an odd number?</p> <p>Answer:</p>	
<p>What is the probability of choosing an even number?</p> <p>Answer:</p>	
<p>What is the probability of choosing a prime number?</p> <p>Answer:</p>	
<p>What is the probability of choosing 1 or 5?</p> <p>Answer:</p>	
<p>What is the probability of choosing 3 or 4?</p> <p>Answer:</p>	

Numbers from 1 to 50 are written on a piece of paper and dropped into a box. A paper is chosen at random.

<p>Find the probability of choosing multiples of 10.</p> <p>Answer: _____</p>	
<p>Find the probability of choosing an even number.</p> <p>Answer: _____</p>	
<p>Find the probability of choosing an odd number.</p> <p>Answer: _____</p>	
<p>Find the probability of choosing factors of 36.</p> <p>Answer: _____</p>	
<p>Find the probability of choosing neither odd nor prime.</p> <p>Answer: _____</p>	

## Lesson 10: Order of Operations

Simplify using order of operations. Show each of your steps to support your work. You may use a calculator for computation.

1)  $5 + 8 \div 2 - 7$

Ans =

2)  $12 \times 3 - 42 + 20$

Ans =

3)  $25 \times 2 - 42 \div 6 + 18$

Ans =

4)  $3 + 32 \div 8 - 9$

Ans =

5)  $4 \times 5 + 3^3 - 15 \div 5$

Ans =

6)  $9 \times 3^2 \div 9 - 4$

Ans =

7)  $3^3 - (76 \div 2)$

Ans =

8)  $(11 + 9) \times 3^2$

Ans =

Rate Your Understanding: This will be helpful for your 8<sup>th</sup> Grade math teacher ☺

3 – Meets	2 – Refresher	1 – Need to Study
I have a complete understanding of the concept. No further action needed.	I can recall some of the concepts, but need a little refresher.	I forgot how to apply the concept and need to study this section.

Specific Lesson	Rating
Lesson 1: The Real Number System	
Lesson 2: Rational Number Operations	
Lesson 3: Algebraic Expressions	
Lesson 4: Algebraic Equations & Inequalities	
Lesson 5: Direct & Inverse Proportions	
Lesson 6: Angle Properties & Straight Lines	
Lesson 7: Circles, Volume, & Surface Area	
Lesson 8: Statistics	
Lesson 9: Probability	
Lesson 10: Order of Operations	

**Lesson 11: Mixed Problems [Required only for students taking Algebra 1**

SHOW WORK (even for multiple choice questions)! **No work = No credit!**

<p><b>If <math>a = -4</math> and <math>b = \frac{4}{3}</math>, find the value of the expression below.</b></p> $\frac{1}{6}a^2 + \frac{9}{10}b$	<p><b>Simplify the expression below.</b></p> $\frac{5^3 -  -19  + 2}{(5 + 2^2) \cdot 3}$
<p><b>Once simplified, which expression is not equivalent to the other three expressions?</b></p> <p><b>A.</b> <math>4(7 - 2m) - 10</math> <b>B.</b> <math>-5m - 11 - 3m + 29</math> <b>C.</b> <math>m - (9m + 1) + 17</math> <b>D.</b> <math>12 + 4m - 3(4m - 2)</math></p>	<p><b>Simplify, then completely factor the expression below.</b></p> $6(4y + 7) - 3(2y - 1)$ <p><b>A.</b> <math>3(6y + 15)</math> <b>B.</b> <math>3(6y + 13)</math> <b>C.</b> <math>9(2y + 5)</math> <b>D.</b> <math>9(2y + 3)</math></p>
<p><b>Find the solution to the equation below.</b></p> $2(4w - 3) = -2(2w + 15)$	<p><b>Translate and solve: "The difference between two-thirds of a number, <math>n</math>, and eleven is at least 17".</b></p>

Which of the following values is a solution to the inequality below?

$$7n + 8 > 9n + 14$$

- A. 1
- B. 2
- C. -3
- D. -4

The soccer team and the lacrosse team sold tubs of cookie dough as a fundraiser. Each tub sold earns \$5 in profit. If the soccer team sold thirteen less than twice the number of tubs that the lacrosse team sold, and the two teams sold 224 tubs combined, how much money did the soccer team raise?

- A. \$395
- B. \$440
- C. \$725
- D. \$855

Ben is buying a book that costs \$14.75 and a magazine that costs \$5.25. If he has a store coupon for 15% off and sales tax is 8%, how much will he pay in total?

- A. 17.92
- B. 18.36
- C. 18.74
- D. 19.08

If  $m\angle 1 = 61^\circ$ ,  $m\angle 2 = 29^\circ$ ,  $m\angle 3 = 151^\circ$ , and  $m\angle 4 = 29^\circ$ , which statement could be true?

- A.  $\angle 1$  and  $\angle 2$  are vertical angles
- B.  $\angle 2$  and  $\angle 3$  are complementary angles
- C.  $\angle 2$  and  $\angle 4$  are complementary angles
- D.  $\angle 3$  and  $\angle 4$  are supplementary angles

Given the diagram below, if  $m\angle AEC = (5x + 1)^\circ$  and  $m\angle CEB = (9x - 3)^\circ$ , find the value of  $x$ .

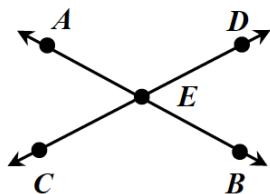

- A.  $x = 1$
- B.  $x = 7$
- C.  $x = 9$
- D.  $x = 13$

What is the perimeter of the shape shown below?

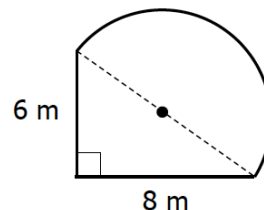

- A.  $P = 29.7$  m
- B.  $P = 36.0$  m
- C.  $P = 45.4$  m
- D.  $P = 58.0$  m

Find the total volume of the figure below.

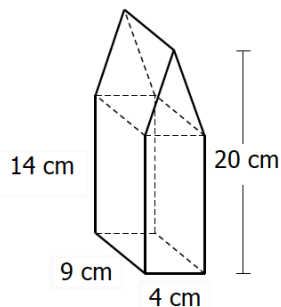

- A.  $598 \text{ cm}^3$
- B.  $612 \text{ cm}^3$
- C.  $674 \text{ cm}^3$
- D.  $709 \text{ cm}^3$

Cone A and Cone B have the same radius. Which statement is true regarding the volume of Cone B compared to the volume of Cone A?

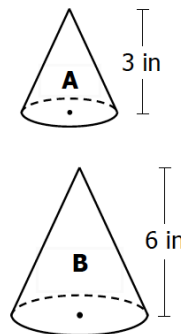

- A. It is two times larger.
- B. It is three times larger.
- C. It is four times larger.
- D. It is nine times larger.

Between which two consecutive numbers does the square root below lie?

$$-\sqrt{128}$$

- A. -13 and -12
- B. -12 and -11
- C. -11 and -10
- D. -10 and -9

Which value is an integer but not a whole number?

- A. 75%
- B.  $5^{-1} \cdot 10$
- C.  $\sqrt{20}$
- D.  $-\frac{4^3}{16}$

Find the solution to the equation below.

$$5(2a - 3) = 13a - 3(a - 5)$$

- A.  $a = -2$
- B.  $a = 5$
- C. No Solution
- D. Infinite Solution

Which graph represents the solution to the inequality below?

$$-\frac{1}{2}(8a - 32) \leq -4$$

- A.
- B.
- C.
- D.