

Dear Students,

To prepare you for next year's Analysis and Trigonometry class, the Math Department requires that you complete a summer review assignment. This review will refresh your skills and prepare you for our Analysis and Trigonometry course.

Copy and solve each problem, **showing all your work**. You will not receive full credit for answers only. Box your answers. Write your name in the upper right-hand corner of the first page.

You are expected to spend a minimum of 4 hours on this assignment, but it may take longer if you are not familiar with the material. ALL assigned problems need to be done in order with all work shown, neat, and stapled. The completed assignment is due the first day of class. We will quickly review the assignment on that day, so bring any questions you have to the first class. We will be having a small assessment on this material during our second class, so you are encouraged to review your work the day before classes start to have it fresh in your mind if you completed the assignment early in the summer. All problems in this review should be material you have already mastered. If there is anything that does not look familiar, please make sure you get the proper help during the summer.

*If you need to brush up on some concepts, here is a link that might be helpful:
www.patrickjmt.com

If you have any questions, you may reach out to the Math Department Chair, Mrs. Brand, at: cbrand@moreaucatholic.org

See you in August!

HERE IS THE ASSIGNMENT:

Do the following problems from the attached pages:

P.2 Exercises: p. 25-26 #49-95 every other odd (i.e. 49, 53, 57, ...), 97

P.3 Exercises: p. 33-34 #9-14 all, 19-29 odd, 37-97 every other odd

P.4 Exercises: p. 42-43 #4, 9-15 odd, 23-103 every other odd

P.5 Exercises: p. 52-53 #7-39 every other odd, 49-65 every other odd, 71

P.2 EXERCISES

See www.CalcChat.com for worked-out solutions to odd-numbered exercises.

VOCABULARY: Fill in the blanks.

- In the exponential form a^n , n is the _____ and a is the _____.
- A convenient way of writing very large or very small numbers is called _____.
- One of the two equal factors of a number is called a _____ of the number.
- The _____ of a number a is the n th root that has the same sign as a , and is denoted by $\sqrt[n]{a}$.
- In the radical form $\sqrt[n]{a}$, the positive integer n is called the _____ of the radical and the number a is called the _____.
- When an expression involving radicals has all possible factors removed, radical-free denominators, and a reduced index, it is in _____.
- Radical expressions can be combined (added or subtracted) if they are _____.
- The expressions $a + b\sqrt{m}$ and $a - b\sqrt{m}$ are _____ of each other.
- The process used to create a radical-free denominator is known as _____ the denominator.
- In the expression $b^{m/n}$, m denotes the _____ to which the base is raised and n denotes the _____ or root to be taken.

SKILLS AND APPLICATIONS

In Exercises 11–18, evaluate each expression.

- | | |
|--|---------------------------------------|
| 11. (a) $3^2 \cdot 3$ | (b) $3 \cdot 3^3$ |
| 12. (a) $\frac{5^5}{5^2}$ | (b) $\frac{3^2}{3^4}$ |
| 13. (a) $(3^3)^0$ | (b) -3^2 |
| 14. (a) $(2^3 \cdot 3^2)^2$ | (b) $(-\frac{3}{5})^3(\frac{5}{3})^2$ |
| 15. (a) $\frac{3}{3^{-4}}$ | (b) $48(-4)^{-3}$ |
| 16. (a) $\frac{4 \cdot 3^{-2}}{2^{-2} \cdot 3^{-1}}$ | (b) $(-2)^0$ |
| 17. (a) $2^{-1} + 3^{-1}$ | (b) $(2^{-1})^{-2}$ |
| 18. (a) $3^{-1} + 2^{-2}$ | (b) $(3^{-2})^2$ |

In Exercises 19–22, use a calculator to evaluate the expression. (If necessary, round your answer to three decimal places.)

- | | |
|-----------------------|--------------------------|
| 19. $(-4)^3(5^2)$ | 20. $(8^{-4})(10^3)$ |
| 21. $\frac{3^6}{7^3}$ | 22. $\frac{4^3}{3^{-4}}$ |

In Exercises 23–30, evaluate the expression for the given value of x .

- | | |
|-----------------------------------|-------------------------------------|
| 23. $-3x^3$, $x = 2$ | 24. $7x^{-2}$, $x = 4$ |
| 25. $6x^0$, $x = 10$ | 26. $5(-x)^3$, $x = 3$ |
| 27. $2x^3$, $x = -3$ | 28. $-3x^4$, $x = -2$ |
| 29. $-20x^2$, $x = -\frac{1}{2}$ | 30. $12(-x)^3$, $x = -\frac{1}{3}$ |

In Exercises 31–38, simplify each expression.

- | | |
|-----------------------------------|--|
| 31. (a) $(-5z)^3$ | (b) $5x^4(x^2)$ |
| 32. (a) $(3x)^2$ | (b) $(4x^3)^0$, $x \neq 0$ |
| 33. (a) $6y^2(2y^0)^2$ | (b) $\frac{3x^5}{x^3}$ |
| 34. (a) $(-z)^3(3z^4)$ | (b) $\frac{25y^8}{10y^4}$ |
| 35. (a) $\frac{7x^2}{x^3}$ | (b) $\frac{12(x+y)^3}{9(x+y)}$ |
| 36. (a) $\frac{r^4}{r^6}$ | (b) $(\frac{4}{y})^3(\frac{3}{y})^4$ |
| 37. (a) $[(x^2y^{-2})^{-1}]^{-1}$ | (b) $(\frac{a^{-2}}{b^{-2}})(\frac{b}{a})^3$ |
| 38. (a) $(6x^7)^0$, $x \neq 0$ | (b) $(5x^2z^6)^3(5x^2z^6)^{-3}$ |

In Exercises 39–44, rewrite each expression with positive exponents and simplify.

- | | |
|---|--|
| 39. (a) $(x+5)^0$, $x \neq -5$ | (b) $(2x^2)^{-2}$ |
| 40. (a) $(2x^5)^0$, $x \neq 0$ | (b) $(z+2)^{-3}(z+2)^{-1}$ |
| 41. (a) $(-2x^2)^3(4x^3)^{-1}$ | (b) $(\frac{x}{10})^{-1}$ |
| 42. (a) $(4y^{-2})(8y^4)$ | (b) $(\frac{x^{-3}y^4}{5})^{-3}$ |
| 43. (a) $3^n \cdot 3^{2n}$ | (b) $(\frac{a^{-2}}{b^{-2}})(\frac{b}{a})^3$ |
| 44. (a) $\frac{x^2 \cdot x^n}{x^3 \cdot x^n}$ | (b) $(\frac{a^{-3}}{b^{-3}})(\frac{a}{b})^3$ |

P.2

In Exercises 45–52, write the number in scientific notation.

45. 10,250.4
 46. $-7,280,000$
 47. -0.000125
 48. 0.00052
 49. Land area of Earth: 57,300,000 square miles
 50. Light year: 9,460,000,000,000 kilometers
 51. Relative density of hydrogen: 0.0000899 gram per cubic centimeter
 52. One micron (millionth of a meter): 0.00003937 inch

In Exercises 53–60, write the number in decimal notation.

53. 1.25×10^5
 54. -1.801×10^5
 55. -2.718×10^{-3}
 56. 3.14×10^{-4}
 57. Interior temperature of the sun:
 1.5×10^7 degrees Celsius
 58. Charge of an electron: 1.6022×10^{-19} coulomb
 59. Width of a human hair: 9.0×10^{-5} meter
 60. Gross domestic product of the United States in 2007:
 1.3743021×10^{13} dollars (Source: U.S. Department of Commerce)

In Exercises 61 and 62, evaluate each expression without using a calculator.

61. (a) $(2.0 \times 10^9)(3.4 \times 10^{-4})$
 (b) $(1.2 \times 10^7)(5.0 \times 10^{-3})$
 62. (a) $\frac{6.0 \times 10^8}{3.0 \times 10^{-3}}$
 (b) $\frac{2.5 \times 10^{-3}}{5.0 \times 10^2}$

In Exercises 63 and 64, use a calculator to evaluate each expression. (Round your answer to three decimal places.)

63. (a) $750 \left(1 + \frac{0.11}{365}\right)^{800}$
 (b) $\frac{67,000,000 + 93,000,000}{0.0052}$
 64. (a) $(9.3 \times 10^6)^3(6.1 \times 10^{-4})$
 (b) $\frac{(2.414 \times 10^4)^6}{(1.68 \times 10^5)^5}$

In Exercises 65–70, evaluate each expression without using a calculator.

65. (a) $\sqrt{9}$
 (b) $\sqrt[3]{\frac{27}{8}}$
 66. (a) $27^{1/3}$
 (b) $36^{3/2}$
 67. (a) $32^{-3/5}$
 (b) $\left(\frac{16}{81}\right)^{-3/4}$
 68. (a) $100^{-3/2}$
 (b) $\left(\frac{9}{4}\right)^{-1/2}$
 69. (a) $\left(-\frac{1}{64}\right)^{-1/3}$
 (b) $\left(\frac{1}{\sqrt{32}}\right)^{-2/5}$
 70. (a) $\left(-\frac{125}{27}\right)^{-1/3}$
 (b) $-\left(\frac{1}{125}\right)^{-4/3}$

In Exercises 71–76, use a calculator to approximate the number. (Round your answer to three decimal places.)

71. (a) $\sqrt{57}$
 (b) $\sqrt[3]{-27^3}$
 72. (a) $\sqrt[3]{45^2}$
 (b) $\sqrt[6]{125}$
 73. (a) $(-12.4)^{-1.8}$
 (b) $(5\sqrt{3})^{-2.5}$
 74. (a) $\frac{7 - (4.1)^{-3.2}}{2}$
 (b) $\left(\frac{13}{3}\right)^{-3/2} - \left(-\frac{3}{2}\right)^{13/3}$
 75. (a) $\sqrt{4.5 \times 10^9}$
 (b) $\sqrt[3]{6.3 \times 10^4}$
 76. (a) $(2.65 \times 10^{-4})^{1/3}$
 (b) $\sqrt{9 \times 10^{-4}}$

In Exercises 77 and 78, use the properties of radicals to simplify each expression.

77. (a) $(\sqrt[5]{2})^5$
 (b) $\sqrt[5]{96x^5}$
 78. (a) $\sqrt{12} \cdot \sqrt{3}$
 (b) $\sqrt[4]{(3x^2)^4}$

In Exercises 79–90, simplify each radical expression.

79. (a) $\sqrt{20}$
 (b) $\sqrt[3]{128}$
 80. (a) $\sqrt[3]{\frac{16}{27}}$
 (b) $\sqrt{\frac{75}{4}}$
 81. (a) $\sqrt{72x^3}$
 (b) $\sqrt{\frac{18z^2}{z^3}}$
 82. (a) $\sqrt{54xy^4}$
 (b) $\sqrt{\frac{32a^4}{b^2}}$
 83. (a) $\sqrt[3]{16x^5}$
 (b) $\sqrt{75x^2y^{-4}}$
 84. (a) $\sqrt[4]{3x^4y^2}$
 (b) $\sqrt[5]{160x^8z^4}$
 85. (a) $2\sqrt{50} + 12\sqrt{8}$
 (b) $10\sqrt{32} - 6\sqrt{18}$
 86. (a) $4\sqrt{27} - \sqrt{75}$
 (b) $\sqrt[3]{16} + 3\sqrt[3]{54}$
 87. (a) $5\sqrt{x} - 3\sqrt{x}$
 (b) $-2\sqrt{9y} + 10\sqrt{y}$
 88. (a) $8\sqrt{49x} - 14\sqrt{100x}$
 (b) $-3\sqrt{48x^2} + 7\sqrt{75x^2}$
 89. (a) $3\sqrt{x+1} + 10\sqrt{x+1}$
 (b) $7\sqrt{80x} - 2\sqrt{125x}$
 90. (a) $-\sqrt{x^3-7} + 5\sqrt{x^3-7}$
 (b) $11\sqrt{245x^3} - 9\sqrt{45x^3}$

In Exercises 91–94, complete the statement with $<$, $=$, or $>$.

91. $\sqrt{5} + \sqrt{3}$ $\sqrt{5+3}$
 92. $\sqrt{\frac{3}{11}}$ $\frac{\sqrt{3}}{\sqrt{11}}$
 93. 5 $\sqrt{3^2+2^2}$
 94. 5 $\sqrt{3^2+4^2}$

In Exercises 95–98, rationalize the denominator of the expression. Then simplify your answer.

95. $\frac{1}{\sqrt{3}}$
 96. $\frac{8}{\sqrt[3]{2}}$
 97. $\frac{5}{\sqrt{14}-2}$
 98. $\frac{3}{\sqrt{5}+\sqrt{6}}$

P.3 EXERCISES

See www.CalcChat.com for worked-out solutions to odd-numbered exercises.

VOCABULARY

In Exercises 1–5, fill in the blanks.

- For the polynomial $a_n x^n + a_{n-1} x^{n-1} + \dots + a_1 x + a_0$, $a_n \neq 0$, the degree is _____, the leading coefficient is _____, and the constant term is _____.
- A polynomial in x in standard form is written with _____ powers of x .
- A polynomial with one term is called a _____, while a polynomial with two terms is called a _____, and a polynomial with three terms is called a _____.
- To add or subtract polynomials, add or subtract the _____ by adding their coefficients.
- The letters in “FOIL” stand for the following. F _____ O _____ I _____ L _____

In Exercises 6–8, match the special product form with its name.

- $(u + v)(u - v) = u^2 - v^2$ (a) A binomial sum squared
- $(u + v)^2 = u^2 + 2uv + v^2$ (b) A binomial difference squared
- $(u - v)^2 = u^2 - 2uv + v^2$ (c) The sum and difference of same terms

SKILLS AND APPLICATIONS

In Exercises 9–14, match the polynomial with its description. [The polynomials are labeled (a), (b), (c), (d), (e), and (f).]

- | | |
|---------------------------|---------------------------------|
| (a) $3x^2$ | (b) $1 - 2x^3$ |
| (c) $x^3 + 3x^2 + 3x + 1$ | (d) 12 |
| (e) $-3x^5 + 2x^3 + x$ | (f) $\frac{2}{3}x^4 + x^2 + 10$ |

- A polynomial of degree 0
- A trinomial of degree 5
- A binomial with leading coefficient -2
- A monomial of positive degree
- A trinomial with leading coefficient $\frac{2}{3}$
- A third-degree polynomial with leading coefficient 1

In Exercises 15–18, write a polynomial that fits the description. (There are many correct answers.)

- A third-degree polynomial with leading coefficient -2
- A fifth-degree polynomial with leading coefficient 6
- A fourth-degree binomial with a negative leading coefficient
- A third-degree binomial with an even leading coefficient

In Exercises 19–30, (a) write the polynomial in standard form, (b) identify the degree and leading coefficient of the polynomial, and (c) state whether the polynomial is a monomial, a binomial, or a trinomial.

- | | |
|----------------------------|----------------------|
| 19. $14x - \frac{1}{2}x^5$ | 20. $2x^2 - x + 1$ |
| 21. $x^2 - 4 - 3x^4$ | 22. $7x$ |
| 23. $3 - x^6$ | 24. $-y + 25y^2 + 1$ |

- | | |
|-----------------------|------------------------------|
| 25. 3 | 26. $-8 + t^2$ |
| 27. $1 + 6x^4 - 4x^5$ | 28. $3 + 2x$ |
| 29. $4x^3y$ | 30. $-x^5y + 2x^2y^2 + xy^4$ |

In Exercises 31–36, determine whether the expression is a polynomial. If so, write the polynomial in standard form.

- | | |
|------------------------|------------------------------|
| 31. $2x - 3x^3 + 8$ | 32. $5x^4 - 2x^2 + x^{-2}$ |
| 33. $\frac{3x + 4}{x}$ | 34. $\frac{x^2 + 2x - 3}{2}$ |
| 35. $y^2 - y^4 + y^3$ | 36. $y^4 - \sqrt{y}$ |

In Exercises 37–54, perform the operation and write the result in standard form.

- $(6x + 5) - (8x + 15)$
- $(2x^2 + 1) - (x^2 - 2x + 1)$
- $-(t^3 - 1) + (6t^3 - 5t)$
- $-(5x^2 - 1) - (-3x^2 + 5)$
- $(15x^2 - 6) - (-8.3x^3 - 14.7x^2 - 17)$
- $(15.6w^4 - 14w - 17.4) - (16.9w^4 - 9.2w + 13)$
- $5z - [3z - (10z + 8)]$
- $(y^3 + 1) - [(y^2 + 1) + (3y - 7)]$
- $3x(x^2 - 2x + 1)$
- $y^2(4y^2 + 2y - 3)$
- $-5z(3z - 1)$
- $(-3x)(5x + 2)$
- $(1 - x^3)(4x)$
- $-4x(3 - x^3)$
- $(1.5t^2 + 5)(-3t)$
- $(2 - 3.5y)(2y^3)$
- $-2x(0.1x + 17)$
- $6y(5 - \frac{3}{8}y)$

In Exercises 55–62, perform the operation.

55. Add $7x^3 - 2x^2 + 8$ and $-3x^3 - 4$.
 56. Add $2x^5 - 3x^3 + 2x + 3$ and $4x^3 + x - 6$.
 57. Subtract $x - 3$ from $5x^2 - 3x + 8$.
 58. Subtract $-t^4 + 0.5t^2 - 5.6$ from $0.6t^4 - 2t^2$.
 59. Multiply $(x + 7)$ and $(2x + 3)$.
 60. Multiply $(3x + 1)$ and $(x - 5)$.
 61. Multiply $(x^2 + 2x + 3)$ and $(x^2 - 2x + 3)$.
 62. Multiply $(x^2 + x - 4)$ and $(x^2 - 2x + 1)$.

In Exercises 63–100, multiply or find the special product.

63. $(x + 3)(x + 4)$ 64. $(x - 5)(x + 10)$
 65. $(3x - 5)(2x + 1)$ 66. $(7x - 2)(4x - 3)$
 67. $(x + 10)(x - 10)$ 68. $(2x + 3)(2x - 3)$
 69. $(x + 2y)(x - 2y)$ 70. $(4a + 5b)(4a - 5b)$
 71. $(2x + 3)^2$ 72. $(5 - 8x)^2$
 73. $(x + 1)^3$ 74. $(x - 2)^3$
 75. $(2x - y)^3$ 76. $(3x + 2y)^3$
 77. $(4x^3 - 3)^2$ 78. $(8x + 3)^2$
 79. $(x^2 - x + 1)(x^2 + x + 1)$
 80. $(x^2 + 3x - 2)(x^2 - 3x - 2)$
 81. $(-x^2 + x - 5)(3x^2 + 4x + 1)$
 82. $(2x^2 - x + 4)(x^2 + 3x + 2)$
 83. $[(m - 3) + n][(m - 3) - n]$
 84. $[(x - 3y) + z][(x - 3y) - z]$
 85. $[(x - 3) + y]^2$ 86. $[(x + 1) - y]^2$
 87. $(2r^2 - 5)(2r^2 + 5)$ 88. $(3a^3 - 4b^2)(3a^3 + 4b^2)$
 89. $(\frac{1}{4}x - 5)^2$ 90. $(\frac{3}{5}t + 4)^2$
 91. $(\frac{1}{5}x - 3)(\frac{1}{5}x + 3)$ 92. $(3x + \frac{1}{6})(3x - \frac{1}{6})$
 93. $(2.4x + 3)^2$
 94. $(1.8y - 5)^2$
 95. $(1.5x - 4)(1.5x + 4)$
 96. $(2.5y + 3)(2.5y - 3)$
 97. $5x(x + 1) - 3x(x + 1)$
 98. $(2x - 1)(x + 3) + 3(x + 3)$
 99. $(u + 2)(u - 2)(u^2 + 4)$
 100. $(x + y)(x - y)(x^2 + y^2)$

In Exercises 101–104, find the product. (The expressions are not polynomials, but the formulas can still be used.)

101. $(\sqrt{x} + \sqrt{y})(\sqrt{x} - \sqrt{y})$
 102. $(5 + \sqrt{x})(5 - \sqrt{x})$
 103. $(x - \sqrt{5})^2$
 104. $(x + \sqrt{3})^2$

105. COST, REVENUE, AND PROFIT An electronics manufacturer can produce and sell x MP3 players per week. The total cost C (in dollars) of producing x MP3 players is $C = 73x + 25,000$, and the total revenue R (in dollars) is $R = 95x$.

- (a) Find the profit P in terms of x .
 (b) Find the profit obtained by selling 5000 MP3 players per week.

106. COST, REVENUE, AND PROFIT An artisan can produce and sell x hats per month. The total cost C (in dollars) for producing x hats is $C = 460 + 12x$, and the total revenue R (in dollars) is $R = 36x$.

- (a) Find the profit P in terms of x .
 (b) Find the profit obtained by selling 42 hats per month.

107. COMPOUND INTEREST After 2 years, an investment of \$500 compounded annually at an interest rate r will yield an amount of $500(1 + r)^2$.

- (a) Write this polynomial in standard form.
 (b) Use a calculator to evaluate the polynomial for the values of r shown in the table.

r	$2\frac{1}{2}\%$	3%	4%	$4\frac{1}{2}\%$	5%
$500(1 + r)^2$					

- (c) What conclusion can you make from the table?

108. COMPOUND INTEREST After 3 years, an investment of \$1200 compounded annually at an interest rate r will yield an amount of $1200(1 + r)^3$.

- (a) Write this polynomial in standard form.
 (b) Use a calculator to evaluate the polynomial for the values of r shown in the table.

r	2%	3%	$3\frac{1}{2}\%$	4%	$4\frac{1}{2}\%$
$1200(1 + r)^3$					

- (c) What conclusion can you make from the table?

109. VOLUME OF A BOX A take-out fast-food restaurant is constructing an open box by cutting squares from the corners of a piece of cardboard that is 18 centimeters by 26 centimeters (see figure). The edge of each cut-out square is x centimeters.

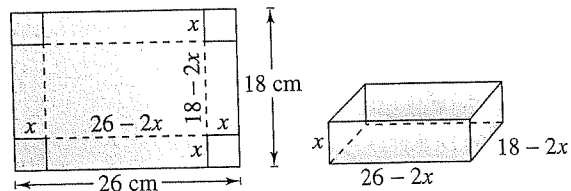

- (a) Find the volume of the box in terms of x .
 (b) Find the volume when $x = 1$, $x = 2$, and $x = 3$.

P.4 EXERCISES

See www.CalcChat.com for worked-out solutions to odd-numbered exercises.

VOCABULARY

In Exercises 1–3, fill in the blanks.

- The process of writing a polynomial as a product is called _____.
- A polynomial is _____ when each of its factors is prime.
- If a polynomial has more than three terms, a method of factoring called _____ may be used.
- Match the factored form of the polynomial with its name.

(a) $u^2 - v^2 = (u + v)(u - v)$	(i) Perfect square trinomial
(b) $u^3 - v^3 = (u - v)(u^2 + uv + v^2)$	(ii) Difference of two squares
(c) $u^2 - 2uv + v^2 = (u - v)^2$	(iii) Difference of two cubes

SKILLS AND APPLICATIONS

In Exercises 5–8, find the greatest common factor of the expressions.

- 80, 280
- 24, 96, 256
- $12x^2y^3, 18x^2y, 24x^3y^2$
- $15(x + 2)^3, 42x(x + 2)^2$

In Exercises 9–16, factor out the common factor.

- $4x + 16$
- $5y - 30$
- $2x^3 - 6x$
- $3z^3 - 6z^2 + 9z$
- $3x(x - 5) + 8(x - 5)$
- $3x(x + 2) - 4(x + 2)$
- $(x + 3)^2 - 4(x + 3)$
- $(5x - 4)^2 + (5x - 4)$

In Exercises 17–22, find the greatest common factor such that the remaining factors have only integer coefficients.

- $\frac{1}{2}x + 4$
- $\frac{1}{3}y + 5$
- $\frac{1}{2}x^3 + 2x^2 - 5x$
- $\frac{1}{3}y^4 - 5y^2 + 2y$
- $\frac{2}{3}x(x - 3) - 4(x - 3)$
- $\frac{4}{3}y(y + 1) - 2(y + 1)$

In Exercises 23–32, completely factor the difference of two squares.

- $x^2 - 81$
- $x^2 - 64$
- $48y^2 - 27$
- $50 - 98z^2$
- $16x^2 - \frac{1}{9}$
- $\frac{4}{25}y^2 - 64$
- $(x - 1)^2 - 4$
- $25 - (z + 5)^2$
- $9u^2 - 4v^2$
- $25x^2 - 16y^2$

In Exercises 33–44, factor the perfect square trinomial.

- $x^2 - 4x + 4$
- $x^2 + 10x + 25$
- $4t^2 + 4t + 1$
- $9x^2 - 12x + 4$
- $25y^2 - 10y + 1$
- $36y^2 - 108y + 81$
- $9u^2 + 24uv + 16v^2$
- $4x^2 - 4xy + y^2$
- $x^2 - \frac{4}{3}x + \frac{4}{9}$
- $z^2 + z + \frac{1}{4}$
- $4x^2 - \frac{4}{3}x + \frac{1}{9}$
- $9y^2 - \frac{3}{2}y + \frac{1}{16}$

In Exercises 45–56, factor the sum or difference of cubes.

- $x^3 - 8$
- $27 - x^3$
- $y^3 + 64$
- $z^3 + 216$
- $x^3 - \frac{8}{27}$
- $y^3 + \frac{8}{125}$
- $8t^3 - 1$
- $27x^3 + 8$
- $u^3 + 27v^3$
- $64x^3 - y^3$
- $(x + 2)^3 - y^3$
- $(x - 3y)^3 - 8z^3$

In Exercises 57–70, factor the trinomial.

- $x^2 + x - 2$
- $x^2 + 5x + 6$
- $s^2 - 5s + 6$
- $t^2 - t - 6$
- $20 - y - y^2$
- $24 + 5z - z^2$
- $x^2 - 30x + 200$
- $x^2 - 13x + 42$
- $3x^2 - 5x + 2$
- $2x^2 - x - 1$
- $5x^2 + 26x + 5$
- $12x^2 + 7x + 1$
- $-9z^2 + 3z + 2$
- $-5u^2 - 13u + 6$

In Exercises 71–78, factor by grouping.

- $x^3 - x^2 + 2x - 2$
- $x^3 + 5x^2 - 5x - 25$
- $2x^3 - x^2 - 6x + 3$
- $5x^3 - 10x^2 + 3x - 6$
- $6 + 2x - 3x^3 - x^4$
- $x^5 + 2x^3 + x^2 + 2$
- $6x^3 - 2x + 3x^2 - 1$
- $8x^5 - 6x^2 + 12x^3 - 9$

In Exercises 79–84, factor the trinomial by grouping.

- $3x^2 + 10x + 8$
- $2x^2 + 9x + 9$
- $6x^2 + x - 2$
- $6x^2 - x - 15$
- $15x^2 - 11x + 2$
- $12x^2 - 13x + 1$

In Exercises 85–120, completely factor the expression.

- $6x^2 - 54$
- $12x^2 - 48$
- $x^3 - x^2$
- $x^3 - 4x^2$

- | | |
|---|---|
| 89. $x^3 - 16x$ | 90. $x^3 - 9x$ |
| 91. $x^2 - 2x + 1$ | 92. $16 + 6x - x^2$ |
| 93. $1 - 4x + 4x^2$ | 94. $-9x^2 + 6x - 1$ |
| 95. $2x^2 + 4x - 2x^3$ | 96. $13x + 6 + 5x^2$ |
| 97. $\frac{1}{81}x^2 + \frac{2}{9}x - 8$ | 98. $\frac{1}{8}x^2 - \frac{1}{96}x - \frac{1}{16}$ |
| 99. $3x^3 + x^2 + 15x + 5$ | 100. $5 - x + 5x^2 - x^3$ |
| 101. $x^4 - 4x^3 + x^2 - 4x$ | 102. $3u - 2u^2 + 6 - u^3$ |
| 103. $2x^3 + x^2 - 8x - 4$ | 104. $3x^3 + x^2 - 27x - 9$ |
| 105. $\frac{1}{4}x^3 + 3x^2 + \frac{3}{4}x + 9$ | 106. $\frac{1}{5}x^3 + x^2 - x - 5$ |
| 107. $(t - 1)^2 - 49$ | 108. $(x^2 + 1)^2 - 4x^2$ |
| 109. $(x^2 + 8)^2 - 36x^2$ | 110. $2t^3 - 16$ |
| 111. $5x^3 + 40$ | 112. $4x(2x - 1) + (2x - 1)^2$ |
| 113. $5(3 - 4x)^2 - 8(3 - 4x)(5x - 1)$ | |
| 114. $2(x + 1)(x - 3)^2 - 3(x + 1)^2(x - 3)$ | |
| 115. $7(3x + 2)^2(1 - x)^2 + (3x + 2)(1 - x)^3$ | |
| 116. $7x(2)(x^2 + 1)(2x) - (x^2 + 1)^2(7)$ | |
| 117. $3(x - 2)^2(x + 1)^4 + (x - 2)^3(4)(x + 1)^3$ | |
| 118. $2x(x - 5)^4 - x^2(4)(x - 5)^3$ | |
| 119. $5(x^6 + 1)^4(6x^5)(3x + 2)^3 + 3(3x + 2)^2(3)(x^6 + 1)^5$ | |
| 120. $\frac{x^2}{2}(x^2 + 1)^4 - (x^2 + 1)^5$ | |

GEOMETRIC MODELING In Exercises 121–124, match the factoring formula with the correct “geometric factoring model.” [The models are labeled (a), (b), (c), and (d).] For instance, a factoring model for

$$2x^2 + 3x + 1 = (2x + 1)(x + 1)$$

is shown in the following figure.

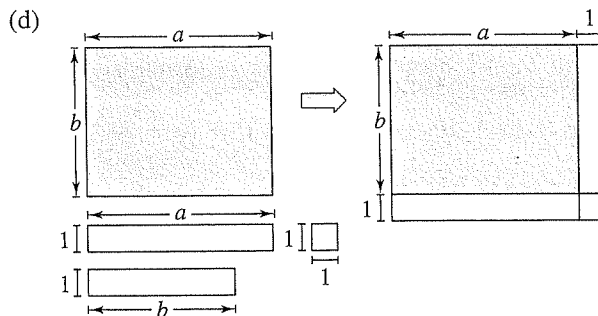
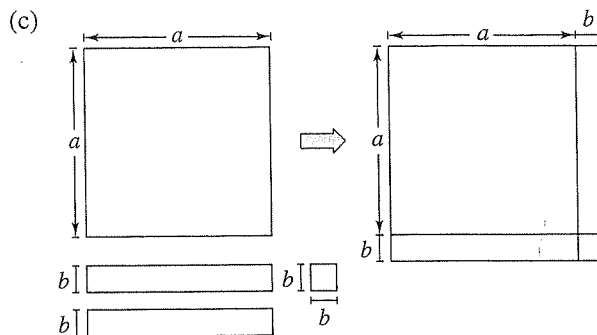
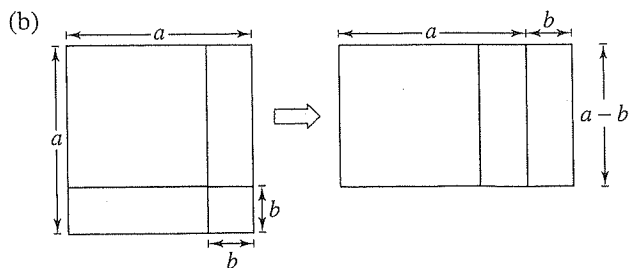
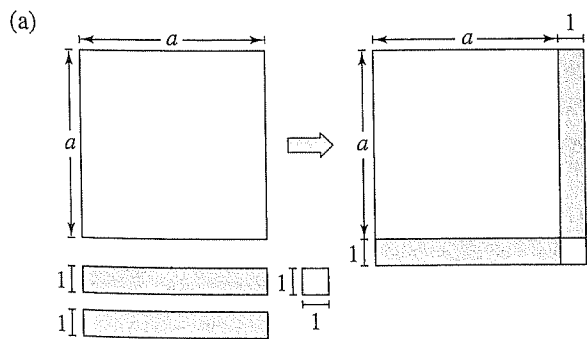
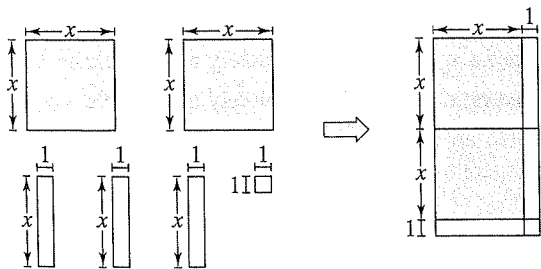

121. $a^2 - b^2 = (a + b)(a - b)$
 122. $a^2 + 2ab + b^2 = (a + b)^2$
 123. $a^2 + 2a + 1 = (a + 1)^2$
 124. $ab + a + b + 1 = (a + 1)(b + 1)$

GEOMETRIC MODELING In Exercises 125–128, draw a “geometric factoring model” to represent the factorization.

125. $3x^2 + 7x + 2 = (3x + 1)(x + 2)$
 126. $x^2 + 4x + 3 = (x + 3)(x + 1)$
 127. $2x^2 + 7x + 3 = (2x + 1)(x + 3)$
 128. $x^2 + 3x + 2 = (x + 2)(x + 1)$

GEOMETRY In Exercises 129–132, write an expression in factored form for the area of the shaded portion of the figure.

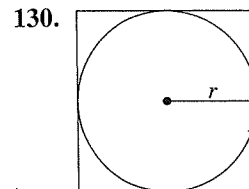
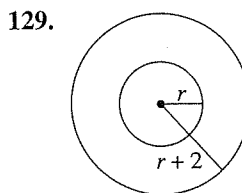

SKILLS AND APPLICATIONS

In Exercises 7–22, find the domain of the expression.

7. $3x^2 - 4x + 7$ 8. $2x^2 + 5x - 2$
 9. $4x^3 + 3, x \geq 0$ 10. $6x^2 - 9, x > 0$
 11. $\frac{1}{3-x}$ 12. $\frac{x+6}{3x+2}$
 13. $\frac{x^2-1}{x^2-2x+1}$ 14. $\frac{x^2-5x+6}{x^2-4}$
 15. $\frac{x^2-2x-3}{x^2-6x+9}$ 16. $\frac{x^2-x-12}{x^2-8x+16}$
 17. $\sqrt{x+7}$ 18. $\sqrt{4-x}$
 19. $\sqrt{2x-5}$ 20. $\sqrt{4x+5}$
 21. $\frac{1}{\sqrt{x-3}}$ 22. $\frac{1}{\sqrt{x+2}}$

In Exercises 23 and 24, find the missing factor in the numerator such that the two fractions are equivalent.

23. $\frac{5}{2x} = \frac{5(\quad)}{6x^2}$ 24. $\frac{3}{4} = \frac{3(\quad)}{4(x+1)}$

In Exercises 25–42, write the rational expression in simplest form.

25. $\frac{15x^2}{10x}$ 26. $\frac{18y^2}{60y^5}$
 27. $\frac{3xy}{xy+x}$ 28. $\frac{2x^2y}{xy-y}$
 29. $\frac{4y-8y^2}{10y-5}$ 30. $\frac{9x^2+9x}{2x+2}$
 31. $\frac{x-5}{10-2x}$ 32. $\frac{12-4x}{x-3}$
 33. $\frac{y^2-16}{y+4}$ 34. $\frac{x^2-25}{5-x}$
 35. $\frac{x^3+5x^2+6x}{x^2-4}$ 36. $\frac{x^2+8x-20}{x^2+11x+10}$
 37. $\frac{y^2-7y+12}{y^2+3y-18}$ 38. $\frac{x^2-7x+6}{x^2+11x+10}$
 39. $\frac{2-x+2x^2-x^3}{x^2-4}$ 40. $\frac{x^2-9}{x^3+x^2-9x-9}$
 41. $\frac{z^3-8}{z^2+2z+4}$ 42. $\frac{y^3-2y^2-3y}{y^3+1}$

43. **ERROR ANALYSIS** Describe the error.

$$\frac{5x^3}{2x^3+4} = \frac{5x^3}{2x^3+4} = \frac{5}{2+4} = \frac{5}{6}$$

44. **ERROR ANALYSIS** Describe the error.

$$\frac{x^3+25x}{x^2-2x-15} = \frac{x(x^2+25)}{(x-5)(x+3)}$$
~~$$= \frac{x(x+5)(x-5)}{(x-5)(x+3)} = \frac{x(x+5)}{x+3}$$~~

In Exercises 45 and 46, complete the table. What can you conclude?

45.

x	0	1	2	3	4	5	6
$\frac{x^2-2x-3}{x-3}$							
$x+1$							

46.

x	0	1	2	3	4	5	6
$\frac{x-3}{x^2-x-6}$							
$\frac{1}{x+2}$							

GEOMETRY In Exercises 47 and 48, find the ratio of the area of the shaded portion of the figure to the total area of the figure.

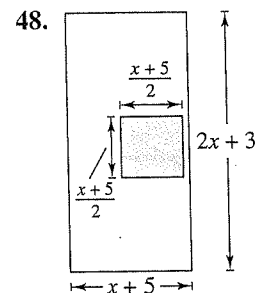
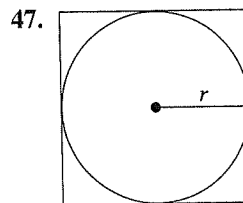

In Exercises 49–56, perform the multiplication or division and simplify.

49. $\frac{5}{x-1} \cdot \frac{x-1}{25(x-2)}$ 50. $\frac{x+13}{x^3(3-x)} \cdot \frac{x(x-3)}{5}$
 51. $\frac{r}{r-1} \div \frac{r^2}{r^2-1}$ 52. $\frac{4y-16}{5y+15} \div \frac{4-y}{2y+6}$
 53. $\frac{t^2-t-6}{t^2+6t+9} \cdot \frac{t+3}{t^2-4}$
 54. $\frac{x^2+xy-2y^2}{x^3+x^2y} \cdot \frac{x}{x^2+3xy+2y^2}$
 55. $\frac{x^2-36}{x} \div \frac{x^3-6x^2}{x^2+x}$
 56. $\frac{x^2-14x+49}{x^2-49} \div \frac{3x-21}{x+7}$

In Exercises 57–68, perform the addition or subtraction and simplify.

57. $6 - \frac{5}{x+3}$

58. $\frac{3}{x-1} - 5$

59. $\frac{5}{x-1} + \frac{x}{x-1}$

60. $\frac{2x-1}{x+3} + \frac{1-x}{x+3}$

61. $\frac{3}{x-2} + \frac{5}{2-x}$

62. $\frac{2x}{x-5} - \frac{5}{5-x}$

63. $\frac{4}{2x+1} - \frac{x}{x+2}$

64. $\frac{2}{x-3} + \frac{5x}{3x+4}$

65. $\frac{1}{x^2-x-2} - \frac{x}{x^2-5x+6}$

66. $\frac{2}{x^2-x-2} + \frac{10}{x^2+2x-8}$

67. $-\frac{1}{x} + \frac{2}{x^2+1} + \frac{1}{x^3+x}$

68. $\frac{2}{x+1} + \frac{2}{x-1} + \frac{1}{x^2-1}$

ERROR ANALYSIS In Exercises 69 and 70, describe the error.

69. ~~$$\frac{x+4}{x+2} - \frac{3x-8}{x+2} = \frac{x+4-3x-8}{x+2}$$

$$= \frac{-2x-4}{x+2} = \frac{-2(x+2)}{x+2} = -2$$~~

70. ~~$$\frac{6-x}{x(x+2)} + \frac{x+2}{x^2} + \frac{8}{x^2(x+2)}$$

$$= \frac{x(6-x) + (x+2)^2 + 8}{x^2(x+2)}$$

$$= \frac{6x - x^2 + x^2 + 4 + 8}{x^2(x+2)}$$

$$= \frac{6(x+2)}{x^2(x+2)} = \frac{6}{x^2}$$~~

In Exercises 71–76, simplify the complex fraction.

71. $\frac{\left(\frac{x}{2} - 1\right)}{(x-2)}$

72. $\frac{(x-4)}{\left(\frac{x}{4} - \frac{4}{x}\right)}$

73. $\frac{\left[\frac{x^2}{(x+1)^2}\right]}{\left[\frac{x}{(x+1)^3}\right]}$

74. $\frac{\left(\frac{x^2-1}{x}\right)}{\left[\frac{(x-1)^2}{x}\right]}$

75. $\frac{\left(\sqrt{x} - \frac{1}{2\sqrt{x}}\right)}{\sqrt{x}}$

76. $\frac{\left(\frac{t^2}{\sqrt{t^2+1}} - \sqrt{t^2+1}\right)}{t^2}$

In Exercises 77–82, factor the expression by removing the common factor with the smaller exponent.

77. $x^5 - 2x^{-2}$

78. $x^5 - 5x^{-3}$

79. $x^2(x^2+1)^{-5} - (x^2+1)^{-4}$

80. $2x(x-5)^{-3} - 4x^2(x-5)^{-4}$

81. $2x^2(x-1)^{1/2} - 5(x-1)^{-1/2}$

82. $4x^3(2x-1)^{3/2} - 2x(2x-1)^{-1/2}$

In Exercises 83 and 84, simplify the expression.

83. $\frac{3x^{1/3} - x^{-2/3}}{3x^{-2/3}}$

84. $\frac{-x^3(1-x^2)^{-1/2} - 2x(1-x^2)^{1/2}}{x^4}$

In Exercises 85–88, simplify the difference quotient.

85. $\frac{\left(\frac{1}{x+h} - \frac{1}{x}\right)}{h}$

86. $\frac{\left[\frac{1}{(x+h)^2} - \frac{1}{x^2}\right]}{h}$

87. $\frac{\left(\frac{1}{x+h-4} - \frac{1}{x-4}\right)}{h}$

88. $\frac{\left(\frac{x+h}{x+h+1} - \frac{x}{x+1}\right)}{h}$

In Exercises 89–94, simplify the difference quotient by rationalizing the numerator.

89. $\frac{\sqrt{x+2} - \sqrt{x}}{2}$

90. $\frac{\sqrt{z-3} - \sqrt{z}}{3}$

91. $\frac{\sqrt{t+3} - \sqrt{3}}{t}$

92. $\frac{\sqrt{x+5} - \sqrt{5}}{x}$

93. $\frac{\sqrt{x+h+1} - \sqrt{x+1}}{h}$

94. $\frac{\sqrt{x+h-2} - \sqrt{x-2}}{h}$

PROBABILITY In Exercises 95 and 96, consider an experiment in which a marble is tossed into a box whose base is shown in the figure. The probability that the marble will come to rest in the shaded portion of the box is equal to the ratio of the shaded area to the total area of the figure. Find the probability.

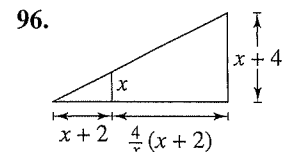
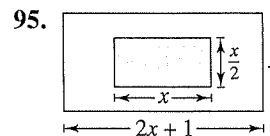

97. **RATE** A digital copier copies in color at a rate of 50 pages per minute.

(a) Find the time required to copy one page.