



CAAC Design and Construction Update

February 19, 2026



Fletcher Miller School MOA – Crossland

Ribbon Cutting
3/18/2026
12:30PM



Issue to Monitor - AC has not been started yet – need stretch of warm temperatures

Conifer HS - Bleachers Norcon

Fabrication
Summer Install



SAFETY – Life Cycle

District Wide Mechanical I

Construction

Swanson, Mandalay (ordered - install this spring), Slater
Columbine Engineering
JCOR (CMGC) Construction Manager/General Contractor

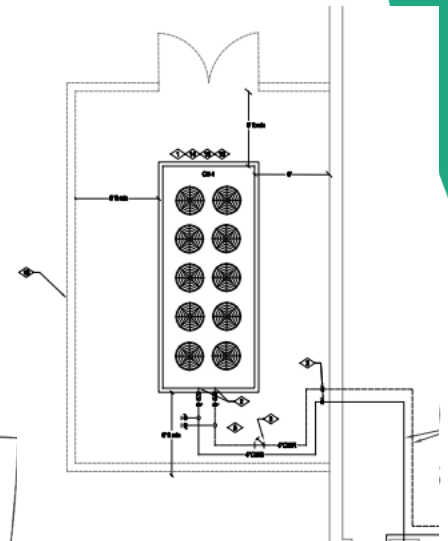
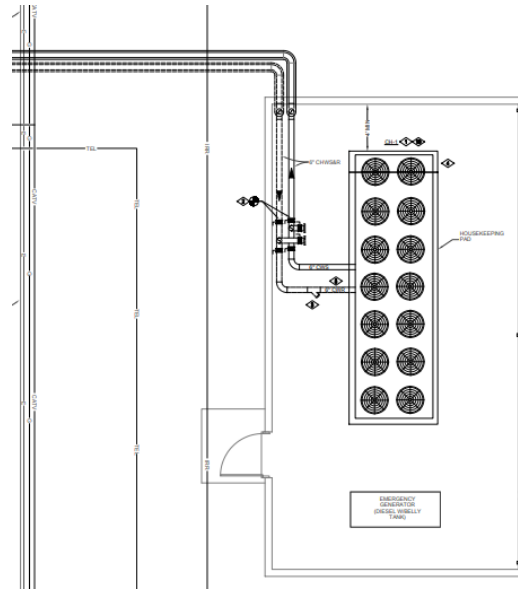
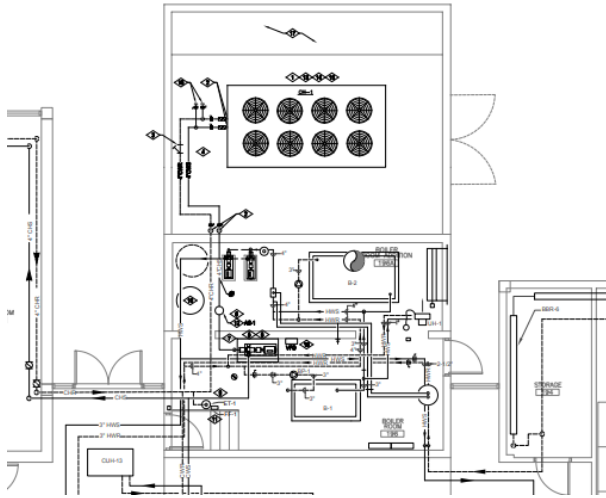

Life Cycle

District Wide Mechanical II

Lasley, Stein, Deane

Columbine Engineering

US Eng (CMGC) Construction Manager/General Contractor

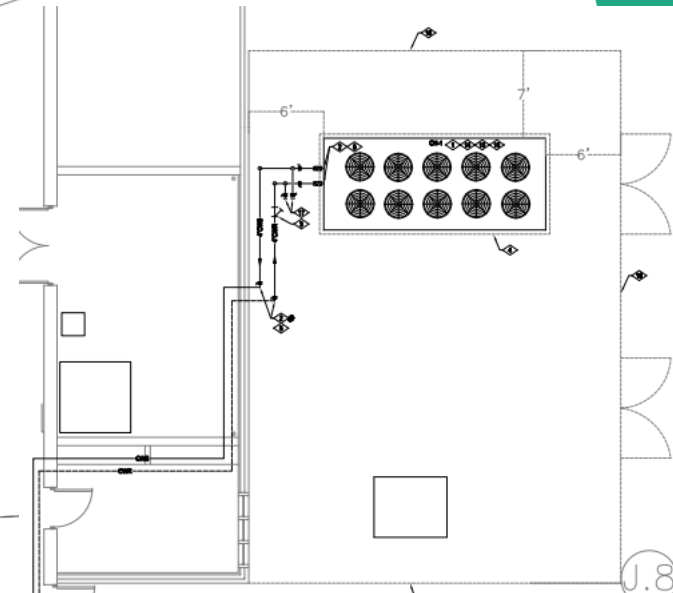
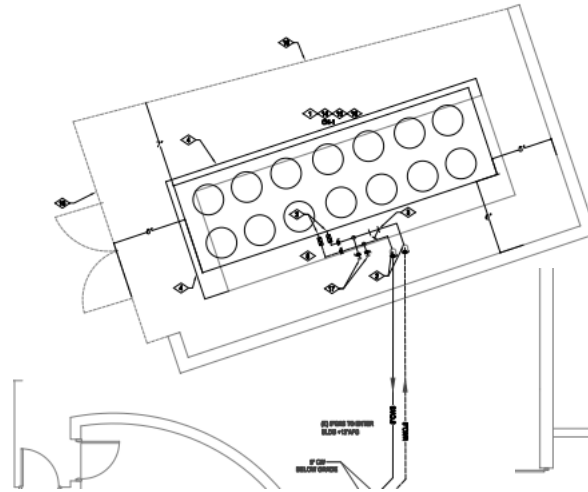
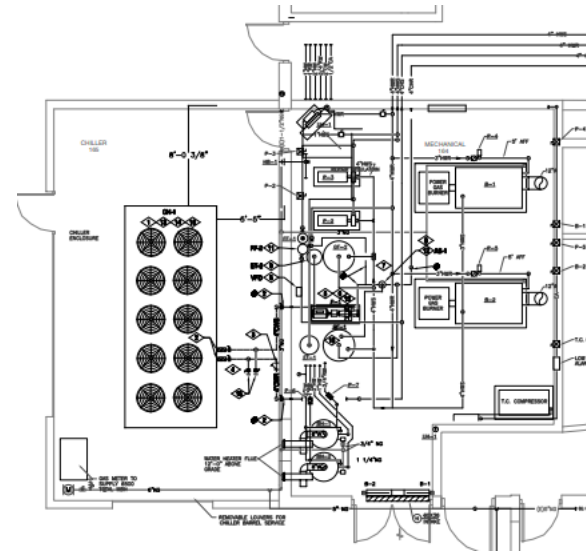

District Wide Flooring Mandalay, Weber, West Woods

Construction

Eidos Single Track

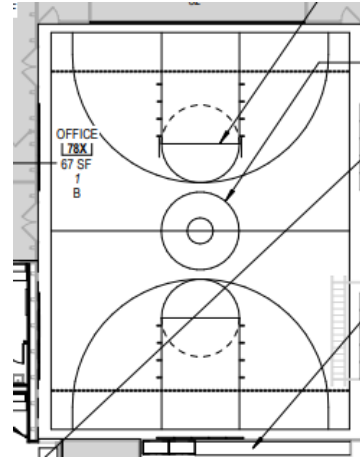
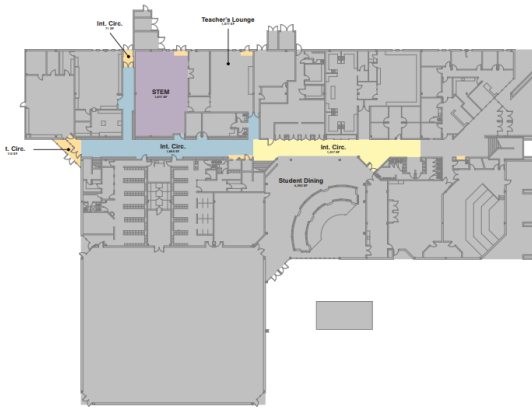

Budget	\$	617,426
Bid 1/15/26	\$	483,732
Under	\$	133,694

District Wide Roofing

Contract BOE
February Consent
Agenda

Standley Lake HS, Alameda International SR+dK Colorado Moisture Control, Inc.

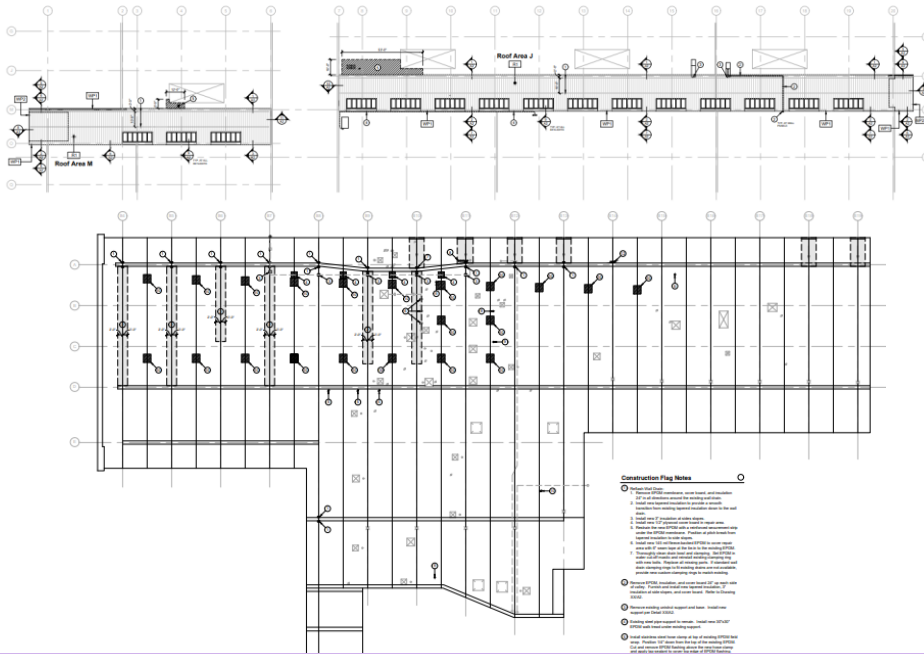

Title: **Bidding Procedures for Capital Construction Projects**
Code: DJE-R
Section: D: Fiscal Management

Life Cycle

Budget	\$ 1,600,000
Bid 1/20/26	\$ 1,342,532
Under	\$ 257,468

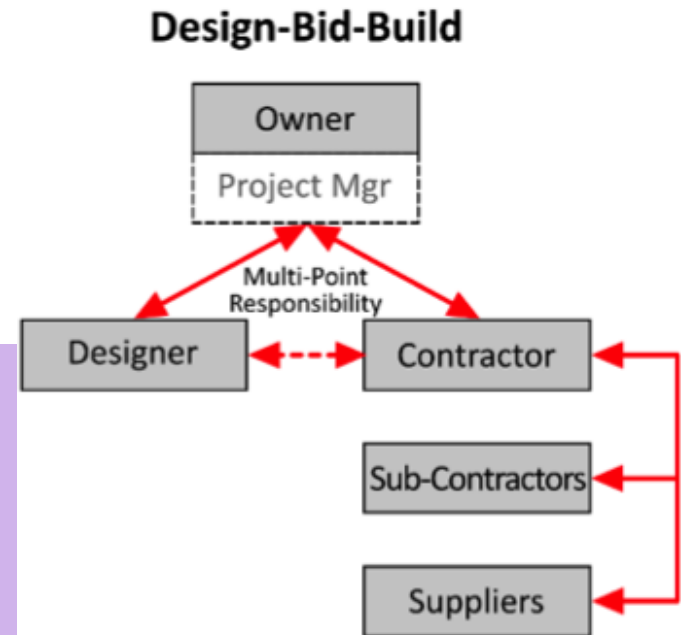

District Wide Paving
 JHS, Columbine HS, Fairmount,
 Kendallvue, Pomona, D'Evelyn,
 Lawrence allowance, WRHS Field Stairs Possible

JVA Crossland (CMGC)

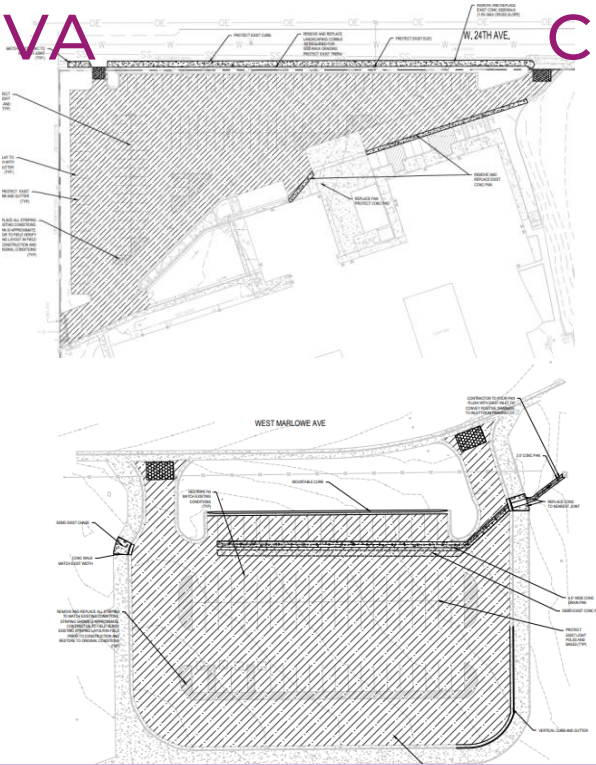

Contract BOE
 February Consent
 Agenda

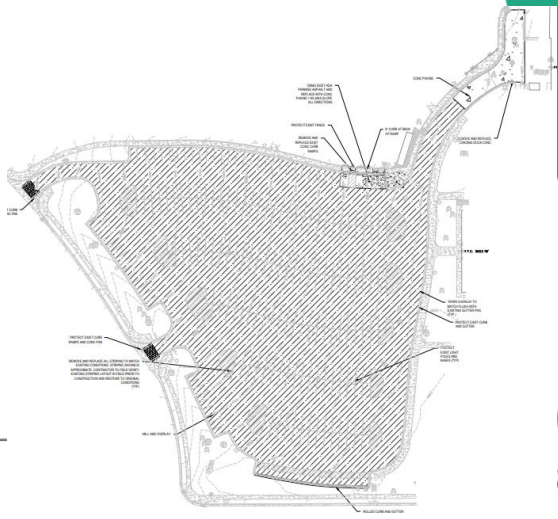
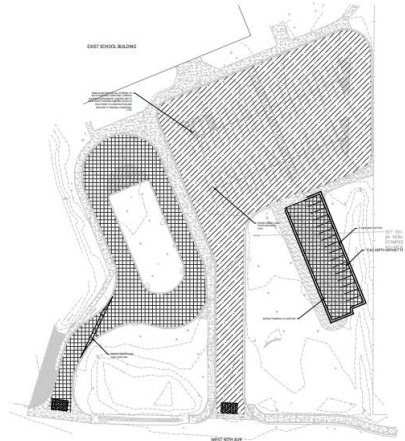

SAFETY – Life Cycle

Budget	\$	3,000,000
GMP 1/26/26	\$	2,370,881
Under	\$	629,119

Green Gables – Boiler Replacement

Bid – Award
GMP

Columbine Engineering US Engineering (CMGC)

Jeffco Maintenance providing \$130k in support

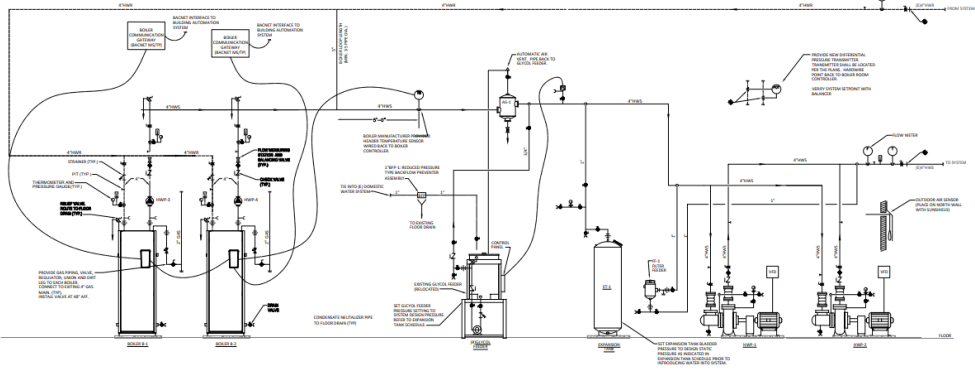

Title: **Bidding Procedures for Capital Construction Projects**
Code: DJE-R
Section: D: Fiscal Management

Life Cycle

Budget	\$	374,198.00
GMP 1/9/26	\$	476,253.64
Over	\$	102,055.64

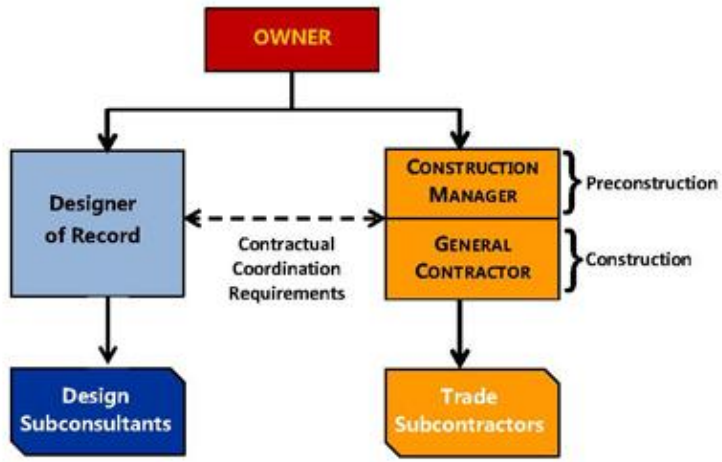

Bradford North K-8 – HVAC Units 1 2 3 4 5

Columbine Engineering

US Engineering (CMGC)

Bid – Award
GMP

Life Cycle

3 Units (Classrooms)
2 Units (Gym/Admin)

Budget was \$449k for 2 units - All units 31 years old

\$449,037 * 5 = \$1,796,148

Cost to Replace all units = **\$1,872,449.52**

or **\$468,112** per unit



Mechanical Plan West – Indicating areas served by each unit.

- Blue – RTU-1
- Green – RTU-2
- Magenta – RTU-3
- Orange – RTU-4
- Cyan – RTU-5

Bradford North K-8 – HVAC Units 1, 3 & 5

Columbine Engineering
3 Units (Classrooms)

Bid – Award
GMP

US Engineering (CMGC)



Title: **Bidding Procedures for Capital Construction Projects**

Code: DJE-R

Section: D: Fiscal Management

Life Cycle

Budget \$ 449,037.00

GMP 1/9/26 \$1,114,920.52

Over \$ 665,883.52

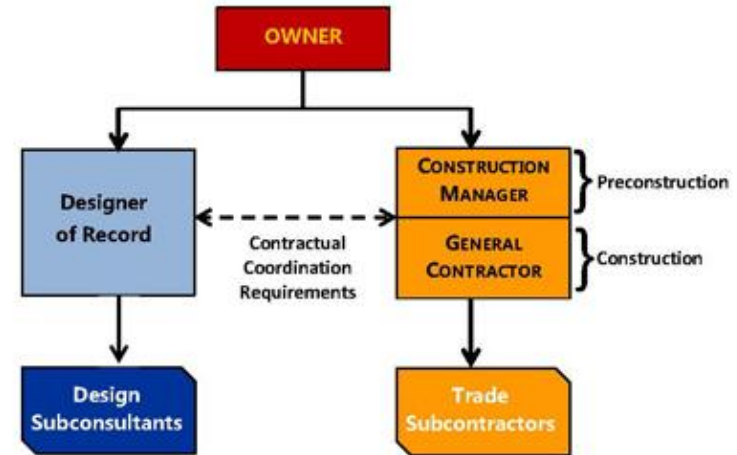

Bradford North K-8 – HVAC

Units 2 & 4

Columbine Engineering

US Engineering (CMGC)

2 Units (Gym/Admin)

Future Phase II



Life Cycle



Mechanical Plan West – Indicating areas served by each unit.

- Blue – RTU-1
- Green – RTU-2
- Magenta – RTU-3
- Orange – RTU-4
- Cyan – RTU-5

Future Phase II Budget \$757,529



Fletcher Miller - Abatement Clear / MOA EDI

Bid – Award
GMP



**Bidding Procedures for
Capital Construction Projects**
Code: DJE-R
Section: D: Fiscal Management

Budget (Project & Hazmat contingency)	\$ 550,000
Bid 2/12/22	\$ 892,155
Over	\$ 342,155

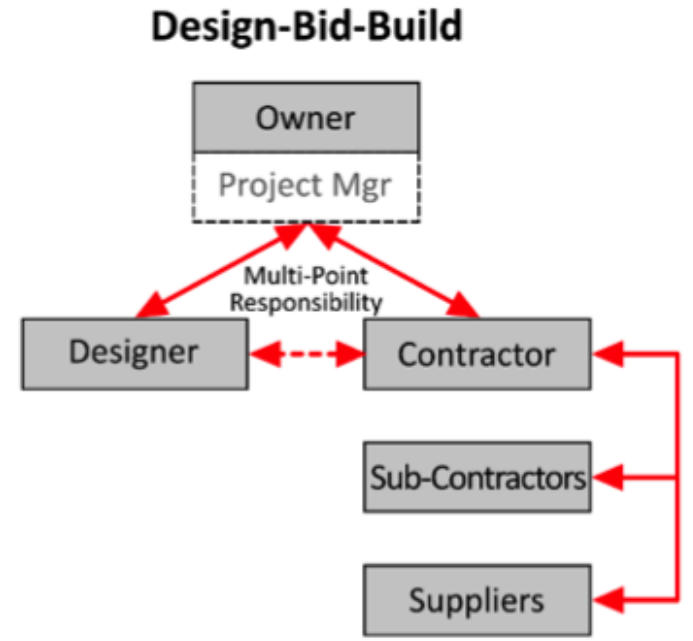

Wayne Carle MS - Flooring RB+B TBD

Bids 2/23/26

Life Cycle

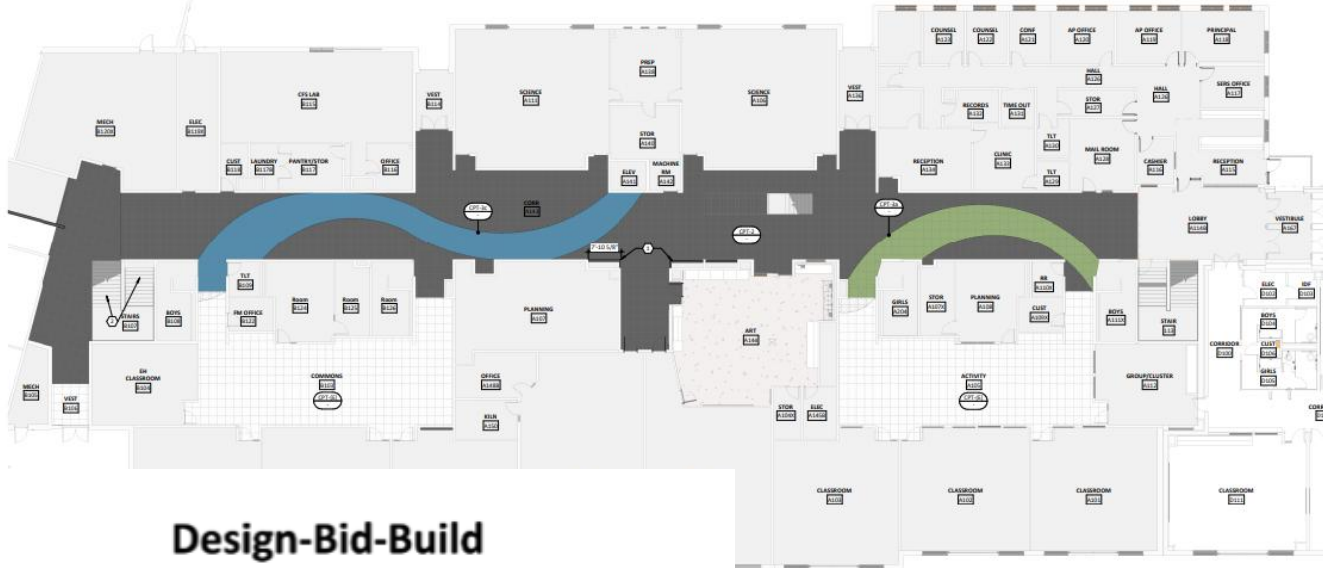

Design-Bid-Build

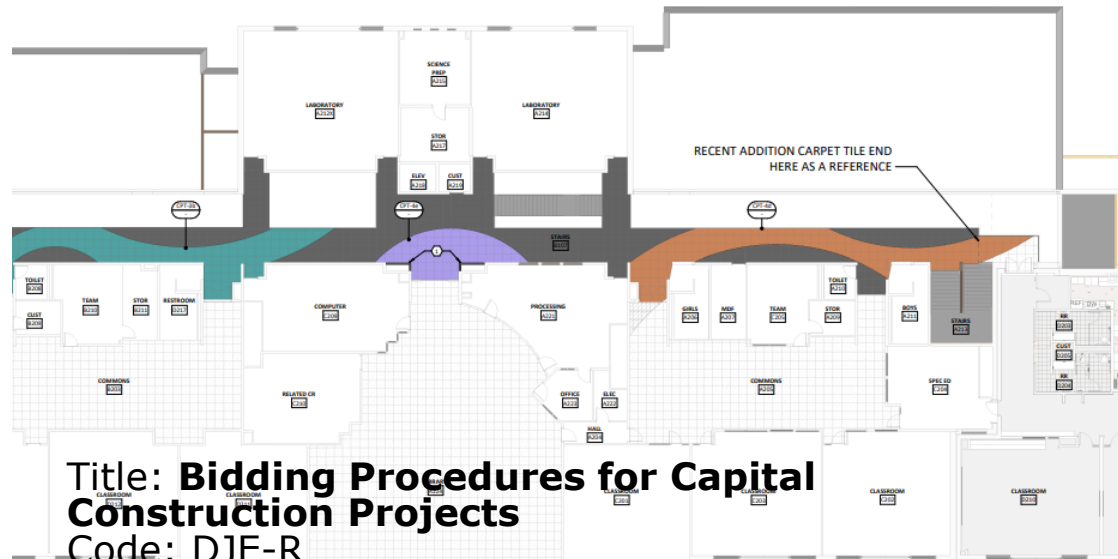
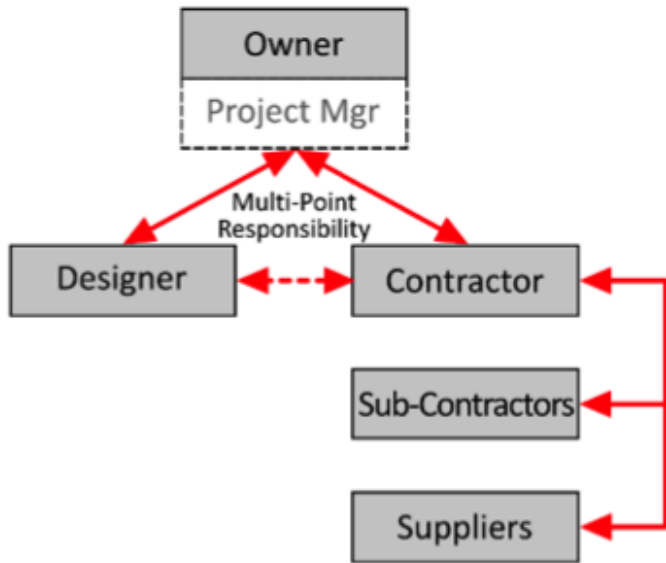

Title: **Bidding Procedures for Capital Construction Projects**
Code: DJE-R
Section: D: Fiscal Management

District Wide – Playgrounds – Parmalee, Bergen, Shelton Design Concepts TBD

Bids 2/26/26

SAFETY – Life Cycle

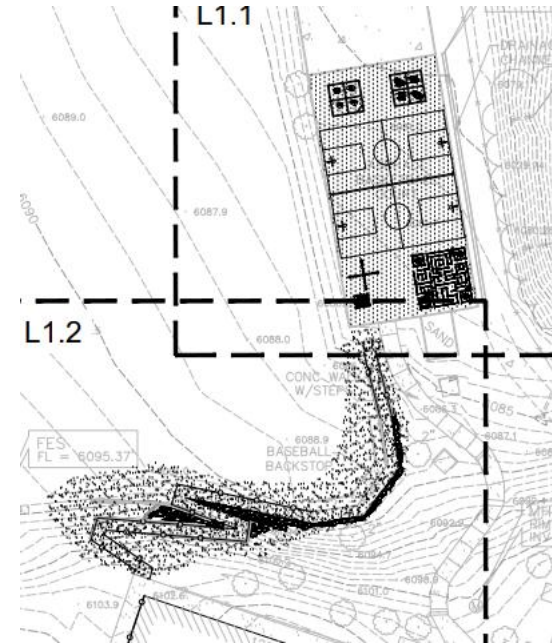
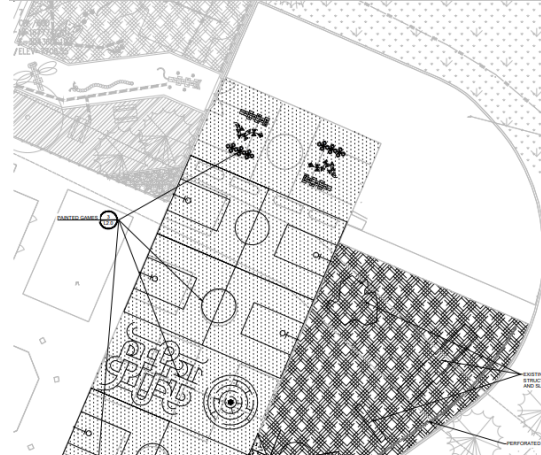
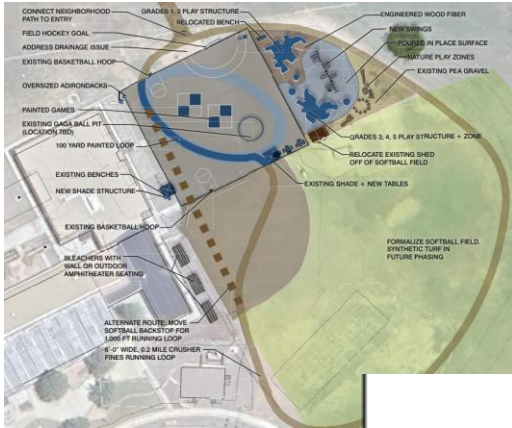

Design-Bid-Build

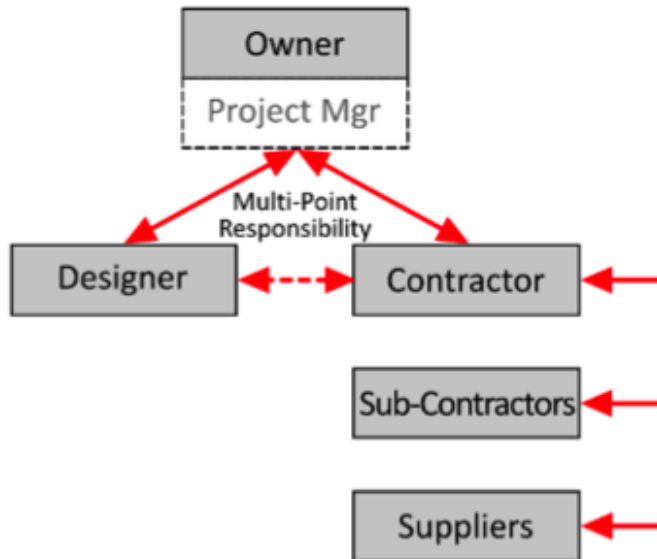

Title: **Bidding Procedures for Capital Construction Projects**
Code: DJE-R
Section: D: Fiscal Management



Fire Alarm System Windy Peak & MT Blue Sky Outdoor Labs

GMP Mar 2026

TLH GTC (CMGC)

Title: **Bidding Procedures for Capital Construction Projects**
Code: DJE-R
Section: D: Fiscal Management

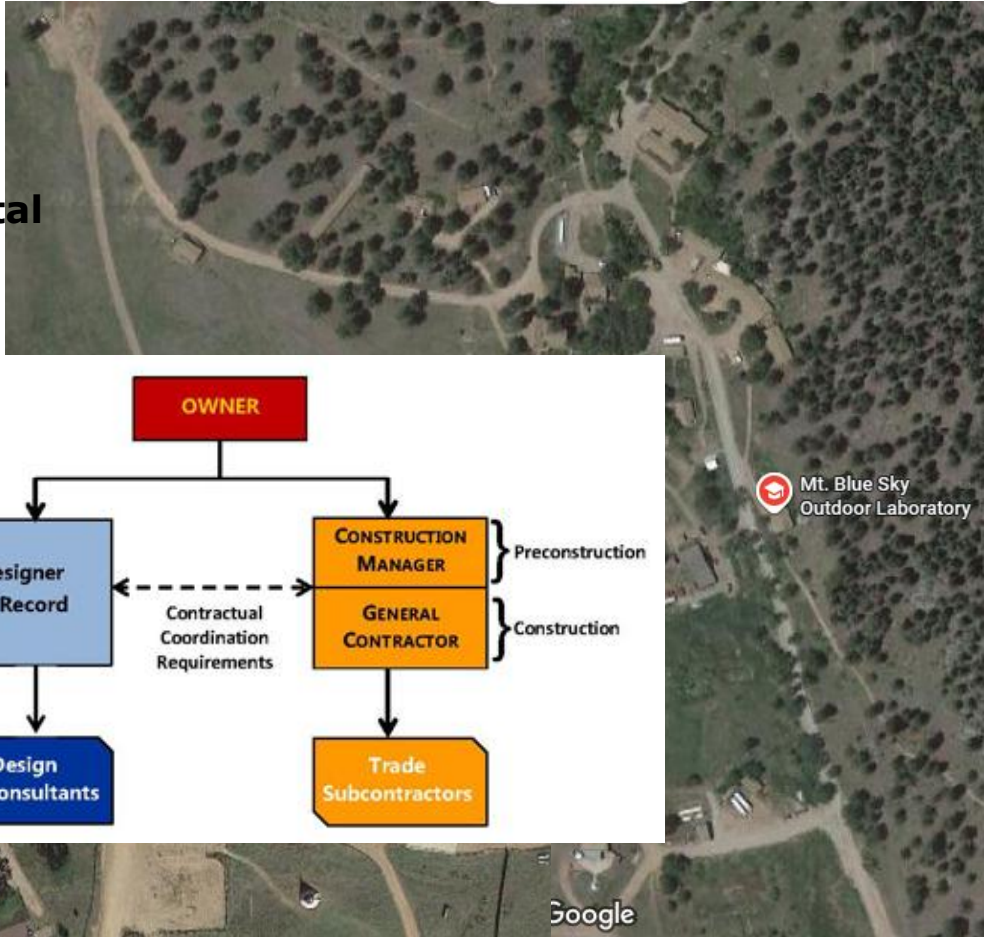

AES System Pilot Successful

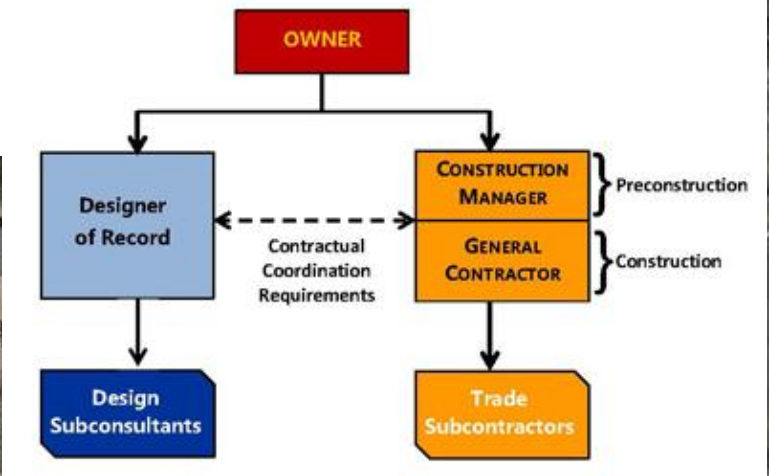

SAFETY – Life Cycle

District Wide – Water Projects Conifer Clarifier, Conifer Water Tank (GMP Jan), Windy Peak New Infiltration Galery, Conifer Aeration System

JVA

Velocity CMGC

SAFETY – Life Cycle

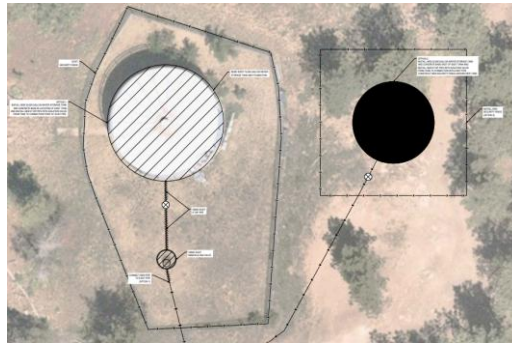

CD's - JVA	CMGC – Velocity
GMP 2/17/26	\$625,464
GMP 2/19/26	\$741,414
Below Budget	\$140,548
	\$ 24,598

Re-Evaluate
2027 Project



Door Access System Technology Consulting Solutions

CMGC RFP to be submitted for revue Feb 20th

Alarm Monitoring Software (AKA SIS - AKA SMS)
Software / Option Evaluation

Manitou Software Selected

SAFETY – Life Cycle

Electric Bus Infrastructure Central Bus Terminal

Highland / Xcel Energy



BOE
Approved
Sept 12

Design

Monthly
Meetings

SAFETY – Life Cycle

Thank You!