

| | | | |
|---|--|----------------------|--|
|  | District Five of Lexington and Richland Counties Invitation for Bid | Solicitation # | 2026-008 |
| | | Date Issued | September 05, 2025 |
| | | Procurement Official | Lauren Bové, CPPO, CPPB |
| | | Phone | (803) 476-8182 |
| | | E-Mail Address | D5bids@lexrich5.org |

| | |
|-------------|---|
| DESCRIPTION | Install New Electrical Service for Marquee at Harbison West Elementary School |
|-------------|---|

The Term "Offer" Means Your "Bid" or "Proposal"

| | | |
|---|-------------------------------|--|
| SUBMIT OFFER BY | September 19, 2025 @ 11:00 am | |
| QUESTIONS & SUBSTITUTION REQUESTS MUST BE RECEIVED BY | September 12, 2025 @ 12:00 pm | Electronically to D5bids@lexrich5.org |
| NUMBER OF COPIES TO BE SUBMITTED | One (1) | |

Offers must be submitted in a sealed package. Solicitation number & Opening Date must appear on package exterior.

SUBMIT YOUR SEALED OFFER TO:

**District Five of Lexington and Richland Counties
Purchasing Office
1020 Dutch Fork Road
Irmo, SC 29063**

| | |
|--|----------------------|
| CONFERENCE TYPE: N/A DATE & TIME: As appropriate, see "Conferences - Pre-Bid/Proposal" & "Site Visit" provisions | LOCATION: N/A |
|--|----------------------|

| | |
|-------------------------------|--|
| AWARD & AMENDMENTS | The award, this solicitation, and any amendments will be posted at the following web address: https://www.lexrich5.org/departments/office-of-finance/purchasing/solicitations-and-awards |
|-------------------------------|--|

You **must** submit a signed copy of this form with Your Offer. By submitting a bid or proposal, You agree to be bound by the terms of the Solicitation. You agree to hold Your Offer open for a minimum of sixty (60) calendar days after the Opening Date.

| | | |
|--|-----------------------------|--|
| NAME OF OFFEROR (Full legal name of business submitting the offer) | | OFFEROR'S TYPE OF ENTITY: (Check one) <input type="checkbox"/> Sole Proprietorship <input type="checkbox"/> Partnership <input type="checkbox"/> Corporation (tax-exempt) <input type="checkbox"/> Corporate entity (not tax-exempt) <input type="checkbox"/> Government entity (federal, state, or local) <input type="checkbox"/> Other _____ (See "Signing Your Offer" provision.) |
| AUTHORIZED SIGNATURE (Person signing must be authorized to submit a binding offer to enter into a contract on behalf of Offeror named above.) | | |
| TITLE (Business title of person signing above) | | |
| PRINTED NAME (Printed name of person signing above) | DATE SIGNED | |
| Instructions regarding Offeror's name: Any award issued will be issued to, and the contract will be formed with, the entity identified as the Offeror above. The entity named as the Offeror must be a single and distinct legal entity. Do not use the name of a branch office or a division of a larger entity if the branch or division is not a separate legal entity, <i>i.e.</i> , a separate corporation, partnership, sole proprietorship, etc. | | |
| STATE OF INCORPORATION (If Offeror is a corporation, identify the state of Incorporation.) | TAXPAYER IDENTIFICATION NO. | |

COVER PAGE

PAGE TWO
(Return Page Two with Your Offer)

| | |
|--|---|
| HOME OFFICE ADDRESS (Address for Offeror's home office / principal place of business) | NOTICE ADDRESS (Address to which all procurement and contract related notices should be sent.) (See "Notice" clause) |
| | Area Code - Number - Extension Facsimile |
| | E-Mail Address |

| | |
|---|---|
| PAYMENT ADDRESS (Address to which payments will be sent.) (See "Payment" clause) | ORDER ADDRESS (Address to which purchase orders will be sent) (See "Purchase Orders" and "Contract Documents" clauses) |
| | Order E-Mail Address: |
| <input type="checkbox"/> Payment Address same as Home Office Address <input type="checkbox"/> Payment Address same as Notice Address (check only one) | <input type="checkbox"/> Order Address same as Home Office Address <input type="checkbox"/> Order Address same as Notice Address (check only one) |

ACKNOWLEDGMENT OF AMENDMENTS:
Offerors acknowledge receipt of amendments by indicating amendment number and its date of issue. (See "Amendments to Solicitation" Provision)

| Amend ment No. | Amendment Issue Date | Amendment No. | Amendment Issue Date | Amendment No. | Amendment Issue Date | Amendment No. | Amendment Issue Date |
|----------------------|-------------------------|------------------|-------------------------|------------------|-------------------------|------------------|-------------------------|
| | | | | | | | |
| | | | | | | | |

| | | | | |
|--|----------------------|----------------------|----------------------|-------------------------|
| DISCOUNT FOR PROMPT PAYMENT (See "Discount for Prompt Payment" clause) | 10 Calendar Days (%) | 20 Calendar Days (%) | 30 Calendar Days (%) | _____ Calendar Days (%) |
| | _____ | _____ | _____ | |

PREFERENCES - A NOTICE TO VENDORS (SEP. 2009): On June 16, 2009, the South Carolina General Assembly rewrote the law governing preferences available to in-state vendors, vendors using in-state subcontractors, and vendors selling in-state or US end products. This law appears in Section 11-35-1524 of the South Carolina Code of Laws. A summary of the new preferences is available at www.procurement.sc.gov/preferences. **ALL THE PREFERENCES MUST BE CLAIMED AND ARE APPLIED BY LINE ITEM, REGARDLESS OF WHETHER AWARD IS MADE BY ITEM OR LOT. VENDORS ARE CAUTIONED TO CAREFULLY REVIEW THE STATUTE BEFORE CLAIMING ANY PREFERENCES. THE REQUIREMENTS TO QUALIFY HAVE CHANGED. IF YOU REQUEST A PREFERENCE, YOU ARE CERTIFYING THAT YOUR OFFER QUALIFIES FOR THE PREFERENCE YOU'VE CLAIMED. IMPROPERLY REQUESTING A PREFERENCE CAN HAVE SERIOUS CONSEQUENCES.** [11-35-1524(E)(4)&(6)]

PREFERENCES - ADDRESS AND PHONE OF IN-STATE OFFICE: Please provide the address and phone number for your in-state office in the space provided below. An in-state office is necessary to claim either the Resident Vendor Preference (11-35-1524(C)(1)(i)&(ii)) or the Resident Contractor Preference (11-35-1524(C)(1)(iii)). Accordingly, you must provide this information to qualify for the preference. An in-state office is not required, but can be beneficial, if you are claiming the Resident Subcontractor Preference (11-35-1524(D)).

In-State Office Address same as Home Office Address
 In-State Office Address same as Notice Address (check only one)

TABLE OF CONTENTS

- I. Scope of Solicitation
- II. Instructions to Offerors
 - A. General Instructions
 - B. Special Instructions
- III. Scope of Work / Specifications
- IV. Information for Offerors to Submit
- V. Qualifications
- VI. Award Criteria
- VII. Terms and Conditions
 - A. General
 - B. Special
- VIII. Bidding Schedule / Cost Proposal
- IX. Attachments to Solicitation

I. SCOPE OF SOLICITATION

School District Five of Lexington and Richland Counties is soliciting competitive sealed bids from qualified sources to install an electrical system for a marquee located at Harbison West Elementary School, located at 257 Crossbow Dr., Columbia, SC 29212. The scope of work shall include furnishing all labor, materials, supplies, and equipment to perform all work required (including cutting, channeling, chasing, excavating and backfilling) to install a complete and working electrical system(s) in accordance with all project specifications and drawings.

ACQUIRE SERVICES & SUPPLIES/EQUIPMENT: The purpose of this solicitation is to acquire services and supplies or equipment complying with the enclosed description and/or specifications and conditions

II. INSTRUCTIONS TO OFFERORS – A. GENERAL INSTRUCTIONS

DEFINITIONS, CAPITALIZATION, AND HEADINGS: CLAUSE HEADINGS USED IN THIS SOLICITATION ARE FOR CONVENIENCE ONLY AND WILL NOT BE USED TO CONSTRUE MEANING OR INTENT. EVEN IF NOT CAPITALIZED, THE FOLLOWING DEFINITIONS APPLY TO ALL PARTS OF THE SOLICITATION, UNLESS EXPRESSLY PROVIDED OTHERWISE.

AMENDMENT means a document issued to supplement the original solicitation document.

BOARD means the Board of Trustees of District Five of Lexington and Richland Counties.

BUSINESS means any corporation, partnership, individual, sole proprietorship, joint stock company, joint venture, or any other legal entity.

CHANGE ORDER means any written alteration in specifications, delivery point, rate of delivery, period of performance, price, quantity, or other provisions of any contract accomplished by mutual agreement of the parties to the contract.

CONTRACT means all types of District Five of Lexington and Richland Counties' agreements, regardless of what they may be called, for the procurement or disposal of supplies, services, equipment or construction.

CONTRACT MODIFICATION means a written order signed by the Procurement Officer, directing the Contractor to make changes which the clause of the contract TITLED "Changes, "if included herein, authorizes the Procurement Coordinator to order without the consent of the Contractor.

CONTRACTOR means the Offeror receiving an award as a result of this solicitation.

COVER PAGE means the top page of the original solicitation on which the solicitation is identified by number. Offerors are cautioned that Amendments may modify information provided on the Cover Page.

OFFER means the bid or proposal submitted in response this solicitation. The terms Bid and Proposal are used interchangeably with the term Offer.

OFFEROR means the single legal entity submitting the offer. The term Bidder is used interchangeably with the term Offeror. See bidding provisions entitled Signing Your Offer and Bid/Proposal As Offer To Contract.

PAGE TWO means the second page of the original solicitation, which is labeled Page Two.

PROCUREMENT OFFICER means the person, or his successor, identified as such on either the Cover Page, an amendment, or an award notice.

YOU and YOUR means Offeror.

SOLICITATION means this document, including all its parts, attachments, and any Amendments.

SUBCONTRACTOR means any person you contract with to perform or provide any part of the work.

WORK means all labor, materials, equipment, services, or property of any type, provided or to be provided by the Contractor to fulfill the Contractor's obligations under the Contract

AMENDMENTS TO SOLICITATION: (a) The Solicitation may be amended at any time prior to opening. All bidders requesting the bid package will be sent copies of all amendments. (b) Offerors shall acknowledge receipt of any amendment to this solicitation (1) by signing and returning the amendment, (2) by identifying the amendment number and date in the space provided for this purpose on Page Two (3) by letter, or (4) by submitting a bid that indicates in some way that the bidder received the amendment. (c) If this solicitation is amended, then all terms and conditions which are not modified remain unchanged.

AUTHORIZED AGENT: All authority regarding this procurement is vested solely with the responsible Procurement Officer. Unless specifically delegated in writing, the Procurement Officer is the only government official authorized to bind the government with regard to this procurement or the resulting contract.

AWARD NOTIFICATION: Notice regarding any award, cancellation of award, or extension of award will be posted at the location and on the date specified on the Cover Page or, if applicable, the most recent notice of extension of award. Should the contract resulting from this Solicitation have a total or potential value more than one hundred thousand dollars, such notice will be sent electronically to all Offerors responding to the Solicitation. Unless a written notice of intent to protest is timely filed pursuant to Section 11-35-4210(1)(b) or the award is otherwise suspended or canceled, the award will be effective on the calendar day (including weekends and holidays) immediately following the seventh business day after such notice is given. When only one response is received, the notice of intended award and the seven-day delay of award may be waived.

BID/PROPOSAL AS OFFER TO CONTRACT: By submitting Your Bid or Proposal, You are offering to enter into a contract with District Five of Lexington and Richland Counties. Without further action by either party, a binding contract shall result upon final award. Any award issued will be issued to, and the contract will be formed with, the entity identified as the Offeror on the Cover Page. An Offer may be submitted by only one legal entity; "joint bids" are not allowed.

BID ACCEPTANCE PERIOD: In order to withdraw Your Offer after the minimum period specified on the Cover Page, You must notify the Procurement Officer in writing.

BID IN ENGLISH and DOLLARS: Offers submitted in response to this solicitation shall be in the English language and in US dollars, unless otherwise permitted by the Solicitation.

CERTIFICATE OF INDEPENDENT PRICE DETERMINATION: GIVING FALSE, MISLEADING, OR INCOMPLETE INFORMATION ON THIS CERTIFICATION MAY RENDER YOU SUBJECT TO PROSECUTION UNDER SECTION 16-9-10 OF THE SOUTH CAROLINA CODE OF LAWS AND OTHER APPLICABLE LAWS.

(a) By submitting an offer, the offeror certifies that-

(1) The prices in this offer have been arrived at independently, without, for the purpose of restricting competition, any consultation, communication, or agreement with any other offeror or competitor relating to—

(i) Those prices;

(ii) The intention to submit an offer; or

(iii) The methods or factors used to calculate the prices offered.

(2) The prices in this offer have not been and will not be knowingly disclosed by the Offeror, directly or indirectly, to any other Offeror or competitor before bid opening (in the case of a sealed bid solicitation) or contract award (in the case of a negotiated solicitation) unless otherwise required by law; and

(3) No attempt has been made or will be made by the Offeror to induce any other concern to submit or not to submit an offer for the purpose of restricting competition.

(b) Each signature on the offer is considered to be a certification by the signatory that the signatory-

(1) Is the person in the Offeror's organization responsible for determining the prices being offered in this bid or proposal, and that the signatory has not participated and will not participate in any action contrary to paragraphs (a)(1) through (a)(3) of this certification; or

(2)(i) Has been authorized, in writing, to act as agent for the Offeror's principals in certifying that those principals have not participated, and will not participate in any action contrary to paragraphs (a)(1) through (a)(3) of this certification [As used in this subdivision (b)(2)(i), the term "principals" means the person(s) in the offeror's organization responsible for determining the prices offered in this bid or proposal];

(ii) As an authorized agent, does certify that the principals referenced in subdivision (b)(2)(i) of this certification have not participated, and will not participate, in any action contrary to paragraphs (a)(1) through (a)(3) of this certification; and

(iii) As an agent, has not personally participated, and will not participate, in any action contrary to paragraphs (a)(1) through (a)(3) of this certification.

(c) If the Offeror deletes or modifies paragraph (a)(2) of this certification, the offeror must furnish with its offer a signed statement setting forth in detail the circumstances of the disclosure.

CERTIFICATION REGARDING DEBARMENT AND OTHER RESPONSIBILITY MATTERS:

(a)

(1) By submitting an Offer, Offeror certifies, to the best of its knowledge and belief, that-

(i) Offeror and/or any of its Principals

(A) Are not presently debarred, suspended, proposed for debarment, or declared ineligible for the award of contracts by any state or federal agency;

(B) Have not, within a three-year period preceding this offer, been convicted of or had a civil judgment rendered against them for: commission of fraud or a criminal offense in connection with obtaining, attempting to obtain, or performing a public (Federal, state, or local) contract or subcontract; violation of Federal or state antitrust statutes relating to the submission of offers; or commission of embezzlement, theft, forgery, bribery, falsification or destruction of records, making false statements, tax evasion, or receiving stolen property; and

(C) Are not presently indicted for, or otherwise criminally or civilly charged by a governmental entity with, commission of any of the offenses enumerated in paragraph (a)(1)(i)(B) of this provision.

(ii) Offeror has not, within a three-year period preceding this offer, had one or more contracts terminated for default by any public (Federal, state, or local) entity.

(2) "Principals," for the purposes of this certification, means officers; directors; owners; partners; and, persons having primary management or supervisory responsibilities within a business entity (e.g., general manager; plant manager; head of a subsidiary, division, or business segment, and similar positions).

(b) Offeror shall provide immediate written notice to the Procurement Officer if, at any time prior to contract award, Offeror learns that its certification was erroneous when submitted or has become erroneous by reason of changed circumstances.

(c) If Offeror is unable to certify the representations stated in paragraphs (a)(1), Offer must submit a written explanation regarding its inability to make the certification. The certification will be considered in connection with a review of the Offeror's responsibility. Failure of the Offeror to furnish additional information as requested by the Procurement Officer may render the Offeror non-responsible.

(d) Nothing contained in the foregoing shall be construed to require establishment of a system of records in order to render, in good faith, the certification required by paragraph (a) of this provision. The knowledge and information of an Offeror is not required to exceed that which is normally possessed by a prudent person in the ordinary course of business dealings.

(e) The certification in paragraph (a) of this provision is a material representation of fact upon which reliance was placed when making award. If it is later determined that the Offeror knowingly or in bad faith rendered an erroneous certification, in addition to other remedies available to the District, the Procurement Officer may terminate the contract resulting from this solicitation for default.

Check for federal and state disbarments at www.sam.gov and <http://procurement.sc.gov/legal/legal-suspend-debar>.

CODE OF LAWS AVAILABLE: The District's Procurement Code is available at: www.lexrich5.org.

DISCLOSURE OF CONFLICTS OF INTEREST OR UNFAIR COMPETITIVE ADVANTAGE: ("OCI FAQ for Contractors" is available at www.procurement.sc.gov)

(a) You certify that, after reasonable inquiry, to the best of your knowledge and belief: (1) your offer identifies any services that relate to either this solicitation or the work and that have already been performed by you, a proposed subcontractor, or an affiliated business or consultant of either; and (2) there are no relevant facts or circumstances that may give rise to an actual or potential organizational conflict of interest, as defined in S.C. Code Ann. Reg. 19-445.2127, or that your offer identifies and explains any unfair competitive advantage you may have in competing for the proposed contract and any actual or potential conflicts of interest that may arise from your participation in this competition or your receipt of an award.

(b) If you, a proposed subcontractor, or an affiliated business or consultant of either, have an unfair competitive advantage or an actual or potential conflict of interest, the District may withhold award. Before withholding award on these grounds, the District will notify you of the concerns and provide a reasonable opportunity for you to respond. The District may consider efforts to avoid or mitigate such concerns, including restrictions on future activities.

(c) The certification in paragraph (a) of this provision is a material representation of fact upon which the District will rely when considering your offer for award.

DEADLINE FOR SUBMISSION OF OFFER: Any offer received after the Procurement Officer of the District or their designee has declared that the time set for opening has arrived, shall be rejected unless the offer has been delivered to the designated District office or mailroom as instructed on the Cover page prior to the bid opening.

DISTRICT OFFICE CLOSINGS: If an emergency or unanticipated event interrupts normal processes so that offers cannot be received at the District as designated for receipt of bids by the exact time specified in the solicitation, the time specified for receipt of offers will be deemed to be extended to the same time of day specified in the solicitation on the first work day on which normal district processes resume. In lieu of an automatic extension, an Amendment may be issued to reschedule the bid opening. If district offices are closed at the time a pre-bid or pre-proposal conference is scheduled, an Amendment will be issued to reschedule the conference. Useful information may be available at: <http://www.lexrich5.org>

DRUG FREE WORK PLACE CERTIFICATION: By submitting an Offer, Contractor certifies that, if awarded a contract, Contractor will comply with all applicable provisions of The Drug-free Workplace Act, Title 44, Chapter 107 of the South Carolina Code of Laws, as amended.

DUTY TO INQUIRE: Offeror, by submitting an Offer, represents that it has read and understands the Solicitation and that its Offer is made in compliance with the Solicitation. Offerors are expected to examine the Solicitation thoroughly and should request an explanation of any ambiguities, discrepancies, errors, omissions, or conflicting statements in the Solicitation. Failure to do so will be at the Offeror's risk. All ambiguities, discrepancies, errors, omissions, or conflicting statements in the Solicitation shall be interpreted to require the better quality or greater quantity of work and/or materials, unless otherwise directed by amendment. Offeror assumes responsibility for any patent ambiguity in the Solicitation that Offeror does not bring to the District's attention. See clause entitled "Questions from Offerors."

ETHICS CERTIFICATE: By submitting an offer, the offeror certifies that the offeror has and will comply with, and has not, and will not, induce a person to violate Title 8, Chapter 13 of the South Carolina Code of Laws, as amended (ethics act). The following statutes require special attention: Section 8-13-700, regarding use of official position for financial gain; Section 8-13-705, regarding gifts to influence action of public official; Section 8-13-720, regarding offering money for advice or assistance of public official; Sections 8-13-755 and 8-13-760, regarding restrictions on employment by former public official; Section 8-13-775, prohibiting public official with economic interests from acting on contracts; Section 8-13-790, regarding recovery of kickbacks; Section 8-13-1150, regarding statements to be filed by consultants; and Section 8-13-1342, regarding restrictions on contributions by contractor to candidate who participated in awarding of contract. The district may rescind any contract and recover all amounts expended as a result of any action taken in violation of this provision. If contractor participates, directly or indirectly, in the evaluation or award of public contracts, including without limitation, change orders or task orders regarding a public contract, contractor shall, if required by law to file such a statement, provide the statement required by Section 8-13-

1150 to the procurement officer at the same time the law requires the statement to be filed.

MULTIPLE OFFERS: Offerors may submit more than one Offer, provided that each Offer has significant differences other than price. Each separate Offer must satisfy all Solicitation requirements. If this solicitation is an Invitation for Bids, each separate offer must be submitted or uploaded as a separate document and must clearly indicate that it is a separate offer. If this solicitation is a Request for Proposals, multiple offers may be submitted or uploaded as one document, provided that you clearly differentiate between each offer and you submit a separate cost proposal for each offer, if applicable.

OMIT TAXES FROM PRICE: Do not include any sales or use taxes in your price that the District may be required to pay.

OPEN TRADE REPRESENTATION: By submitting an Offer, Offeror represents that Offeror is not currently engaged in the boycott of a person or an entity based in or doing business with a jurisdiction with whom South Carolina can enjoy open trade, as defined in SC Code Section 11-35-5300.

PRICING: (a) Fixed Price. If a fixed price is required, award will not be made on an Offer if the total possible price to the District cannot be determined. (b) Price Reasonableness: Any offer may be rejected if the Procurement Officer determines in writing that it is unreasonable as to price. (c) Unbalanced Pricing. The District will analyze all offers with separately priced line items or subline items to determine if the prices are unbalanced. Unbalanced pricing exists when, despite an acceptable total evaluated price, the price of one or more line items is significantly over or understated. The responsible procurement officer may reject an offer as unreasonably priced if she determines that unbalanced pricing increases performance risk (e.g., it is so unbalanced as to be tantamount to allowing an advance payment) or could result in payment of unreasonably high prices. S.C. Code Ann. Reg. 19-445.2122C.

PROHIBITED COMMUNICATIONS AND DONATIONS: Violation of these restrictions may result in disqualification of your offer, suspension or debarment, and may constitute a violation of law. (a) During the period between publication of the solicitation and final award, you must not communicate, directly or indirectly, with the District or its employees, agents or officials regarding any aspect of this procurement activity, unless otherwise approved in writing by the Procurement Officer. (b) You are advised to familiarize yourself with Regulation 19-445.2165, which restricts donation to a governmental entity with whom you have or seek to have a contract. You represent that your offer discloses any gifts made, directly or through an intermediary, by you or your named subcontractors to or for the benefit of the District during the period beginning eighteen months prior to the Opening Date.

PROTESTS: If you are aggrieved in connection with the solicitation or award of the contract, you may be entitled to protest, but only as provided in Section 11-35-4210. To protest the solicitation or an amendment, your written protest must be received within fifteen Days of the date of the applicable solicitation document is issued. To protest an award, (i) written notice of your intent to protest must be received within seven Business Days of the date the award notice is posted and (ii) your actual written protest must be received within fifteen Days of the date the award notice is posted. Time periods are computed in accordance with Section 11-35-310(13) and the definitions of Day and Business Day. Both protests and notices of intent to protest must be received by the Coordinator of Procurement. (b) Pursuant to Section 11-35-410, documents directly connected to a procurement activity may be available within five days after request. All document requests should be directed to D5bids@lexrich5.org. If a protest is pending, the protestant's lawyer may access otherwise unavailable information by applying to the CPO for the issuance of a protective order.

ANY PROTEST MUST BE ADDRESSED TO THE CHIEF PROCUREMENT OFFICE AND SUBMITTED IN WRITING

(a) by email to D5bids@lexrich5.org, or

(B) School District Five of Lexington and Richland Counties, 1020 Dutch Fork Road, Irmo, SC 29063

Lynda Robinson, Coordinator of Procurement
School District Five of Lexington and Richland Counties
1020 Dutch Fork Road
Irmo, SC 29063
Fax: 803-476-8140

E-Mail: ljobins@lexrich5.org

PUBLIC OPENING: Offers will be publicly opened at the date/time and at the location identified on the Cover Page, or last Amendment, whichever is applicable.

QUESTIONS FROM OFFERORS:

(a) Any prospective Offeror desiring an explanation or interpretation of the solicitation, drawings, specifications, etc., must request it in writing. Questions regarding the original solicitation or any amendment must be received by the Procurement Officer no later than five (5) days prior to opening unless an earlier date is stated on the Cover Page. Label any communication regarding your questions with the name of the procurement officer, and the solicitation's title and number. Oral explanations or instructions will not be binding. Any information given a prospective Offeror concerning a solicitation will be furnished promptly to all other prospective Offerors as an Amendment to the solicitation, if that information is necessary for submitting offers or if the lack of it would be prejudicial to other prospective Offerors. We will not identify you in our answer to your question. (b) The District seeks to permit maximum practicable competition. Offerors are urged to advise the Procurement Officer -- as soon as possible -- regarding any aspect of this procurement, including any aspect of the Solicitation, that unnecessarily or inappropriately limits full and open competition.

Email is the preferred method for submitting with "Questions: Solicitation # as the subject of the email."

Questions must be submitted in an easily copied format such as Word.

Email: D5bids@lexrich5.org

Questions may also be submitted to the address listed on the Cover Page of this document or faxed to (803) 476-8138.

REJECTION/CANCELLATION: The District may cancel this solicitation in whole or in part. The District may reject any or all proposals in whole or in part.

RESPONSIVENESS: (a) Award will not be made on a nonresponsive offer. An offer is nonresponsive (i) if it does not constitute an unambiguous offer to enter into a contract with the District, or (ii) if it imposes conditions inconsistent with, or does not unambiguously agree to, the solicitation's material requirements. (b) Bid as Specified. Offers for supplies or services other than those specified will not be considered unless authorized by the Solicitation.

SIGNING YOUR OFFER: Every Offer must be signed by an individual with actual authority to bind the Offer. (a) If the Offeror is an individual, the Offer must be signed by that individual. If the Offeror is an individual doing business as a firm, the Offer must be submitted in the firm name, signed by the individual, and state that the individual is doing business as a firm. (b) If the Offeror is a partnership, the Offer must be submitted in the partnership name, followed by the words by its Partner, and signed by a general partner. (c) If the Offeror is a corporation, the Offer must be submitted in the corporate name, followed by the signature and title of the person authorized to sign. (d) An Offer may be submitted by a joint venturer involving any combination of individuals, partnerships, or corporations. If the Offeror is a joint venture, the Offer must be submitted in the name of the Joint Venture and signed by every participant in the joint venture in the manner prescribed in paragraphs (a) through (c) above for each type of participant. (e) If an Offer is signed by an agent, other than as stated in subparagraphs (a) through (d) above, the Offer must state that it has been signed by an Agent. Upon request, Offeror must provide proof of the agent's authorization to bind the principal.

TERMINATION: Subject to the provisions below, the contract may be terminated for any reason by the Procurement Department providing a 30-day advance notice in writing to the contractor.

(a) **Termination for Convenience:** In the event that this contract is terminated or canceled upon request and for the convenience of the District without the required thirty (30) days advance written notice, then the District may negotiate reasonable termination costs, if applicable.

(b) **Termination for Cause:** Termination by the District for cause, default, or negligence on the part of the contractor shall be excluded from the foregoing provision; termination costs, if any, shall not apply. The thirty (30) days advance notice requirement is waived and the default provision in this bid shall apply.

DISCLOSURE OF YOUR BID/PROPOSAL & SUBMITTING CONFIDENTIAL DATA: (a) According to Section 11-35-410, any person submitting a document in response or with regard to any solicitation or other request, must comply with instructions provided in the solicitation for marking information exempt from public disclosure.

Information not marked as required by the applicable instructions maybe disclosed to the public. IF YOU IDENTIFY YOUR ENTIRE RESPONSE AS EXEMPT FROM PUBLIC DISCLOSURE, OR IF YOU DO NOT SUBMIT A REDACTED COPY AS REQUIRED, THE DISTRICT MAY, IN ITS SOLE DISCRETION, DETERMINE YOUR BID OR PROPOSAL NONRESPONSIVE AND INELIGIBLE FOR AWARD

(b) By submitting a response to this solicitation or request, Offeror agrees to the public disclosure of every page, or portion thereof, of every document regarding this solicitation or request that was submitted at any time prior to entering into a contract (including, but not limited to, documents contained in a response, documents submitted to clarify a response, and documents submitted during negotiations), unless the page, or portion thereof, was redacted and conspicuously marked "Trade Secret" or "Confidential" or "Protected. (2) agrees that any information not redacted and marked, as required by these bidding instructions, as a "Trade Secret" is not a trade secret as defined by the Trade Secrets Act, and (3) agrees that, notwithstanding any claims or markings otherwise, any prices, commissions, discounts, or other financial figures used to determine the award, as well as the final contract amount, are subject to public disclosure.

(c) If your offer includes any information that you claim is exempt from public disclosure, you must submit one complete copy of your offer from which you have removed or concealed such information (the redacted copy). Except for the information removed or concealed, the redacted copy must be identical to your original offer.

(d) Do not mark your entire response (bid, proposal, quote, etc.) as confidential, trade secret, or protected. If only portions of a page are subject to some protection, do not redact the entire page. The redacted copy must reflect the same pagination as the original and show the empty space from which information was redacted. The Procurement Officer must be able to view, search, copy and print the redacted copy without a password. If your response, or any part thereof, is improperly marked as confidential or trade secret or protected, the District may, in its sole discretion, determine it nonresponsive.

(e) On the redacted copy, you must identify the basis of your claim by marking each redaction as follows: You must separately mark with the word "CONFIDENTIAL" every page, or portion thereof, that you redacted and claim as exempt from public disclosure because it is either (1) a trade secret as defined in Section 30-4-40(a)(1) of the Freedom of Information Act, or (2) privileged and confidential, as that phrase is used in Section 11-35410. You must separately mark with the words "TRADE SECRET" every page, or portion thereof, that you redacted and claim as exempt from public disclosure as a trade secret pursuant to Section 39-8-20 of the Trade Secrets Act. You must separately mark with the word "PROTECTED" every page, or portion thereof, that you redacted and claim as exempt from public disclosure pursuant to Section 11-35- 1810. All markings must be conspicuous; use color, bold, underlining, or some other method in order to conspicuously distinguish the mark from the other text.

(f) In determining whether to release documents, the District will detrimentally rely on your redaction and marking of documents, as required by these bidding instructions, as being either "Confidential" or "Trade Secret" or "Protected". By submitting a response, you agree to defend, indemnify and hold harmless the District, its officers and employees, from every claim, demand, loss, expense, cost, damage or injury, including attorney's fees, arising out of or resulting from withholding information by the District, that you have redacted or marked as "Confidential" or "Trade Secret" or "Protected". (All references to S.C. Code of Laws.)

SUBMITTING A PAPER OFFER OR MODIFICATION: (a) All prices and notations should be printed in ink or typewritten. Errors should be crossed out, corrections entered and initialed by the person signing the bid. Do not modify the solicitation document itself (including bid schedule). (b) (1) All copies of the offer or modification, and any other documents required to be submitted with the offer shall be enclosed in a sealed, opaque envelope or package. (2) Address to the Office of Procurement Services as specified in the Solicitation (3) The envelope or package must show the time and date specified for opening, the solicitation number, and the name and address of the bidder. If the offer or modification is sent by mail or special delivery service (UPS, Federal Express, etc.), the outermost envelope or wrapper must be labeled "OFFER ENCLOSED" on the face thereof. (c) If you are responding to more than one solicitation, submit each offer in a separate envelope or package. (d) Submit the number of copies indicated on the Cover Page. (e) Facsimile or e-mail offers, modifications, or withdrawals, will not be considered unless authorized by the Solicitation.

TAXPAYER IDENTIFICATION NUMBER: (a) If Offeror is owned or controlled by a common parent as defined in paragraph (b) of this provision, Offeror shall submit with its Offer the name and TIN of common parent.

(b) Definitions: "Common parent," as used in this provision, means that corporate entity that owns or controls an affiliated group of corporations that files its Federal income tax returns on a consolidated basis, and of which the Offeror is a member. "Taxpayer Identification Number (TIN)," as used in this provision, means the number required

by the Internal Revenue Service (IRS) to be used by the Offeror in reporting income tax and other returns. The TIN may be either a Social Security Number or an Employer Identification Number.

(c) If Offeror does not have a TIN, Offeror shall indicate if either a TIN has been applied for or a TIN is not required. If a TIN is not required, indicate whether (i) Offeror is a nonresident alien, foreign corporation, or foreign partnership that does not have income effectively connected with the conduct of a trade or business in the United States and does not have an office or place of business or a fiscal paying agent in the United States; (ii) Offeror is an agency or instrumentality of a state or local government; (iii) Offeror is an agency or instrumentality of a foreign government; or (iv) Offeror is an agency or instrumentality of the Federal Government.

VENDOR REGISTRATION: Offerors who have not provided products/services to the District in the past or within the past three years should complete a W-9 and submit it with your offer.

WITHDRAWAL OR CORRECTION OF OFFER: Offers may be withdrawn by written notice received at any time before the exact time set for opening. If the Solicitation authorizes facsimile offers, offers may be withdrawn via facsimile received at any time before the exact time set for opening. A bid may be withdrawn in person by a bidder or its authorized representative if, before the exact time set for opening, the identity of the person requesting withdrawal is established and the person signs a receipt for the bid. The withdrawal and correction of Offers is governed by S.C. Code Section 11-35-1520 and Regulation 19-445.2085.

II. INSTRUCTIONS TO OFFERORS – B. SPECIAL INSTRUCTIONS

BACKGROUND CHECKS: The vendor and all representatives of the vendor must have an acceptable background check to enter school property. At a minimum, the Bidder shall obtain a complete South Carolina statewide criminal background investigation for all individuals and employees performing work or services for Bidder or any other entities such as subcontractors, sub-sub-contractors, and consultants who will perform work or a service on this project. In the event that the individual being investigated is from out of state, the criminal background investigation shall be broadened to include their home state, as well as the state of South Carolina as outlined above. The company providing such information must be recognized by local law enforcement agency as qualified to do so. In addition, the Bidder shall check employees against the National Database of Registered Sex Offenders. Any individual that is registered as a sex offender will not be permitted on school property. All costs associated with these criminal background checks are the responsibility of the bidder. The District reserves the right to request a copy of SLED checks on any representatives of the Vendor who will be on District property. The District reserves the right to deny access to any employee, contractor or person caused to be present on District property by the vendor/contractor. Removal of employees on this basis shall not disrupt the project schedule or cost.

BID SUBMITTAL: All bidding documents must be submitted in a sealed envelope. Do not include more than one bid per envelope. The face of the envelope shall contain the bid title, the bid number, and the date and time of bid opening. Bids not submitted on the bid form will be subject to rejection. The district assumes no responsibility for unmarked or improperly marked envelopes.

BID SAMPLES OR DESCRIPTIVE LITERATURE: Do not submit bid samples or descriptive literature unless expressly requested. Unsolicited bid samples or descriptive literature will not be examined or tested, will not be used to determine responsiveness, and will not be deemed to vary any of the provisions of the solicitation. S.C. Code Ann. Reg. 19445.2077D.

PREFERENCES - A NOTICE TO VENDORS: On June 16, 2009, the South Carolina General Assembly rewrote the law governing preferences available to in-state vendors, vendors using in-state subcontractors, and vendors selling in-state or US end products. This law appears in Section 11-35-1524 of the South Carolina Code of Laws. A summary of the new preferences is available at www.procurement.sc.gov/preferences. ALL THE PREFERENCES MUST BE CLAIMED AND ARE APPLIED BY LINE ITEM, REGARDLESS OF WHETHER AWARD IS MADE BY ITEM OR LOT. VENDORS ARE CAUTIONED TO CAREFULLY REVIEW THE STATUTE BEFORE CLAIMING ANY PREFERENCES. THE REQUIREMENTS TO QUALIFY HAVE CHANGED. IF YOU REQUEST A PREFERENCE, YOU ARE CERTIFYING THAT YOUR OFFER QUALIFIES FOR THE PREFERENCE YOU'VE CLAIMED. IMPROPERLY REQUESTING A PREFERENCE CAN HAVE SERIOUS CONSEQUENCES.

PREFERENCES - RESIDENT CONTRACTOR PREFERENCE: To qualify for the RCP, you must maintain an

office in this state. An office is a nonmobile place for the regular transaction of business or performance of a particular service which has been operated as such by the bidder for at least one year before the bid opening and during that year the place has been staffed for at least fifty weeks by at least two employees for at least thirty-five hours a week each. In addition, you must, at the time you submit your bid, directly employ, or have a documented commitment with, individuals domiciled in South Carolina that will perform services expressly required by the solicitation and your total direct labor cost for those individuals to provide those services must exceed fifty percent of your total bid price. [11-35-1524(C)(1)(iii)] Upon request by the procurement officer, you must identify the persons domiciled in South Carolina that will perform the services involved in the procurement upon which you rely in qualifying for the preference, the services those individuals are to perform, and documentation of your labor cost for each person identified. If requested, your failure to provide this information promptly will be grounds to deny the preference (and, potentially, for other enforcement action).

PREFERENCES - RESIDENT SUBCONTRACTOR PREFERENCE: To qualify for this preference, You must meet the following requirements. (1) You must -- at the time you submit your bid -- have a documented commitment from a single proposed first tier subcontractor to perform some portion of the services expressly required by the solicitation. (2) The subcontractor -- at the time you submit your bid -- must directly employ, or have a documented commitment with, individuals domiciled in South Carolina that will perform services expressly required by the solicitation and the total direct labor cost to the subcontractor for those individuals to provide those services exceeds, as applicable, either twenty percent for a 2% preference or forty percent of bidder's total bid price for a 4% preference. (3) You must identify the subcontractor that will perform the work, the work the subcontractor is to perform, and your factual basis for concluding that the subcontractor's work constitutes the required percentage of the work to be performed in the procurement. [11-35-1524(D)] You can stack this preference, i.e., earn another 2% or 4% preference for each additional qualifying subcontractor, but the preference is capped. [1135-1524(D)(4), (E)(7)] Upon request by the procurement officer, you must identify the persons domiciled in South Carolina that are to perform the services involved in the procurement upon which you rely in qualifying for the preference, the services those individuals are to perform, the employer of those persons, your relationship with the employer, and documentation of the subcontractor's labor cost for each person identified. If requested, your failure to provide this information promptly will be grounds to deny the preference (and, potentially, for other enforcement action). **YOU WILL NOT RECEIVE THE PREFERENCE UNLESS YOU SPECIFY WHETHER YOU ARE CLAIMING THE 2% OR 4% PREFERENCE AND YOU PROVIDE THE INFORMATION REQUIRED BY ITEM (3) ABOVE.**

RESPONSIVENESS – CORRECTION OF NON-CONFORMITY: Offerors will not be given an opportunity to correct any material nonconformity. Any deficiency resulting from a minor informality may be cured or waived at the sole discretion of the Procurement Officer.

SITE VISIT – Bidders are strongly encouraged to visit the site prior to bidding to inspect the site. All visitors are required to check in at the front office of the school.

EVERY RESULTING CONTRACT IS SUBJECT TO ALL TERMS OF THE DISTRICT PROCUREMENT CODE INCLUDING LIMITATIONS AS TO DURATION, RIGHTS OF THE DISTRICT TO TERMINATE AND MEANS OF DISPUTE RESOLUTION. NO RESULTING CONTRACT IS RENEWABLE EXCEPT TO THE EXTENT PROVIDED IN THE SOLICITATION. NO VENDOR TERMS TAKE PRECEDENCE OVER THE SOLICITATION AND DISTRICT PROCUREMENT CODE.

III. SCOPE OF WORK / SPECIFICATIONS

SCOPE OF WORK:

School District Five of Lexington and Richland Counties is soliciting competitive sealed bids from qualified sources to install an electrical system for a marquee located at Harbison West Elementary School, located at 257 Crossbow Dr., Columbia, SC 29212. The scope of work shall include furnishing all labor, materials, supplies, and equipment to perform all work required in accordance with all project specifications and drawings. Work shall include, but not be limited to, boring, cutting, channeling, chasing, excavating and backfilling.

PLEASE REFER TO ATTACHMENT D FOR THE FULL SPECIFICATIONS AND DRAWINGS.

BRAND NAME OR EQUAL: Any manufacturer's names, trade names, brand names or catalogue numbers used in the specifications are for the purpose of describing and establishing general performance and quality levels. Such references are not intended to be restrictive. Offerors are invited to use these and equivalent brands or products provided the quality of the proposed products meet or exceed the quality of the specifications listed for any item. If submitting an equal, the vendor must submit detailed descriptive literature with their offer. The District will determine if the equal meets all required specifications. The bid packet must include a list of all the proposed products.

Substitution Requests must be received electronically to D5bids@lexrich5.org by September 12, 2025 @ 12:00pm. Please provide the manufacturer's published description, catalog, or other descriptive document, explaining in detail, exactly what is being proposed. The District shall reserve the exclusive right to determine products and/or services which are approved as equal to those specified in the solicitation. Substitution Requests must be pre-approved by the District. Samples of each product submitted for pre-approval may be required to be supplied at no cost as part of the pre-approval process. If requested, samples of the proposed products, along with a specification sheet stating the products meet the required bid specifications, must be submitted no later than 7 business days after the District's request.

DELIVERY/ PERFORMANCE LOCATION – PURCHASE ORDER: After award, all deliveries must be made and all services provided to the location specified by the District in its purchase order.

QUALITY- NEW- All materials furnished shall be new and unused.

IV. INFORMATION FOR OFFERORS TO SUBMIT

INFORMATION FOR OFFERORS TO SUBMIT – GENERAL: Offeror shall submit a signed Cover Page, Page Two, and Amendments (if applicable). Offeror should submit all other information and documents requested in this part and in parts II.B. Special Instructions; III. Scope of Work; V. Qualifications; and any appropriate attachments addressed in section IX. Attachments to Solicitations. You should submit a summary of all insurance policies you have or plan to acquire to comply with the insurance requirements stated herein, if any, including policy types; coverage types; limits, sub-limits, and deductibles for each policy and coverage type; the carrier's A.M. Best rating; and whether the policy is written on an occurrence or claims-made basis.

MINORITY PARTICIPATION:

Is the bidder a South Carolina Certified Minority Business? Yes No

Is the bidder a Minority Business certified by another governmental entity? Yes No

If so, please list the certifying governmental entity: _____

Will any of the work under this contract be performed by a SC certified Minority Business as a subcontractor? Yes No

If so, what percentage of the total value of the contract will be performed by a SC certified Minority Business as a subcontractor? _____

Will any of the work under this contract be performed by a minority business certified by another governmental entity as a subcontractor? Yes No

If so, what percentage of the total value of the contract will be performed by a minority business certified by another governmental entity as a subcontractor? _____

If a certified Minority Business is participating in this contract, please indicate all categories for which the Business is certified:

- Traditional minority
- Traditional minority, but female Women (Caucasian females)
- Hispanic minorities
- DOT referral (Traditional minority)
- DOT referral (Caucasian female)
- Temporary certification
- SBA 8 (a) certification referral
- Other minorities (Native American, Asian, etc.)

(If more than one minority contractor will be utilized in the performance of this contract, please provide the information above for each minority business.)

The Department of Administration, Division of Small and Minority Business Contracting and Certification, publishes a list of certified minority firms. The Minority Business Directory is available at the following URL: <http://smbcc.sc.gov> (.)

REFERENCES Provide a minimum of three (3) references from employers with similar contracts. References to include the name, contact person, telephone number, email address, and type of services performed.

SUBMITTING REDACTED OFFERS: If your offer includes any information that you marked as “Confidential,” “Trade Secret,” or “Protected” in accordance with the clause entitled “Submitting Confidential Information,” you must also submit one complete copy of your offer from which you have removed or concealed such information (the redacted copy). The redacted copy should (i) reflect the same pagination as the original, (ii) show the empty space from which information was redacted, and (iii) be submitted on magnetic media. (See clause entitled “Electronic Copies - Required Media and Format.”) Except for the information removed or concealed, the redacted copy must be identical to your original offer, and the Procurement Officer must be able to view, search, copy and print the redacted copy without a password.

V. QUALIFICATIONS

QUALIFICATION OF OFFEROR: (1) To be eligible for award, you must have the capability in all respects to perform fully the contract requirements and the integrity and reliability which will assure good faith performance. We may also consider a documented commitment from a satisfactory source that will provide you with a capability. We may consider information from any source at any time prior to award. We may elect to consider (i) key personnel, any predecessor business, and any key personnel of any predecessor business, including any facts arising prior to the date a business was established, and/or (ii) any subcontractor you identify. (2) You must promptly furnish satisfactory evidence of responsibility upon request. Unreasonable failure to supply requested information is grounds for rejection. (3) Corporate subsidiaries are cautioned that the financial capability of an affiliated or parent company will not be considered in determining financial capability; however, we may elect to consider any security, e.g., letter of credit, performance bond, parent-company corporate guaranty, that you offer to provide. Instructions and forms to help assure acceptability are posted on procurement.sc.gov, link to “Standard Clauses & Provisions.”

QUALIFICATIONS – REQUIRED INFORMATION: Submit the following information or documentation for you and for any subcontractor (at any tier level) that you identify pursuant to the clause titled subcontractor – Identification. Err on the side of inclusion. You represent that the information provided is complete.

(a) A detailed, narrative statement providing the general history and experience of the business in providing work of similar size and scope as described in this solicitation, providing adequate information to establish that you meet all the requirements established herein.

(b) A detailed, narrative statement explaining how offeror has available the appropriate financial, material, equipment, facility, and personnel resources and expertise, or firm commitments to obtain them, necessary to meet all contractual requirements of this solicitation

(c) Offeror shall provide (3) references demonstrating company’s background and experience of contracts that are

similar in size and type, preferably in a K-12 setting. References should be for work completed within the last two (2) years and should be on the same scope as described within this offer (Submit on enclosed Reference Form).

(d) Information reflecting the current financial position. Include the most current financial statement and financial statements for the last two (2) fiscal years. If the financial statements have been audited in accordance with the following requirements, provide the audited version of those statements. [Reference Statement of Financial Accounting Concepts No. 5 (FASB, December, 1984), as amended.]

(e) A list of every South Carolina public body for which supplies or services have been provided at any time during the past three years, if any. By submitting an offer, offeror represents that the list is complete.

(f) List of failed projects, suspensions, debarments, and significant litigation.

SUBCONTRACTOR – IDENTIFICATION: If you intend to subcontract, at any tier level, with another business for any portion of the work and that portion either (1) exceeds 10% of your cost, (2) involves access to any “government information,” as defined in the clause entitled “Information Security - Definitions,” if included, or (3) otherwise involves services critical to your performance of the work (err on the side of inclusion), your offer must identify that business and the work which they are to perform. Identify potential subcontractors by providing the business name, address, phone, taxpayer identification number, and point of contact. In determining your responsibility, the District may contact and evaluate your proposed subcontractors.

VI. AWARD CRITERIA

AWARD CRITERIA - BIDS: Award will be made to the lowest responsive and responsible bidder(s).

AWARD TO ONE OFFEROR: Award will be made to one Offeror.

CONTRACT LIMITATIONS: No sales may be made pursuant to this contract for any item or service that is not expressly listed. No sales may be made pursuant to this contract after expiration of this contract. Violation of this provision may result in termination of this contract and may subject contractor to suspension or debarment.

VII. TERMS AND CONDITIONS – A. GENERAL

ASSIGNMENT, NOVATION, AND CHANGE OF NAME, IDENTITY, OR STRUCTURE:

(a) Contractor shall not assign this contract, or its rights, obligations, or any other interest arising from this contract, or delegate any of its performance obligations, without the express written consent of the responsible procurement officer. The foregoing restriction does not apply to a transfer that occurs by operation of law (e.g., bankruptcy; corporate reorganizations and consolidations, but not including partial asset sales). Notwithstanding the foregoing, contractor may assign monies receivable under the contract provided that the District shall have no obligation to make payment to an assignee until thirty days after contractor (not the assignee) has provided the responsible procurement officer with (i) proof of the assignment, (ii) the identity (by contract number) of the specific District contract to which the assignment applies, and (iii) the name of the assignee and the exact address or account information to which assigned payments should be made. (b) If contractor amends, modifies, or otherwise changes its name, its identity (including its trade name), or its corporate, partnership or other structure, or its FEIN, contractor shall provide the procurement officer prompt written notice of such change. (c) Any name change, transfer, assignment, or novation is subject to the conditions and approval required by Regulation 19-445.2180, which does not restrict transfers by operation of law.

BANKRUPTCY: (a) Notice. In the event the Contractor enters into proceedings relating to bankruptcy, whether voluntary or involuntary, the Contractor agrees to furnish written notification of the bankruptcy to the District. This notification shall be furnished within two (2) days of the initiation of the proceedings relating to the bankruptcy filing. This notification shall include the date on which the bankruptcy petition was filed, the identity of the court in which the bankruptcy petition was filed, and a listing of all District contracts against which final payment has not been made. This obligation remains in effect until final payment under this Contract. (b) Termination. This contract is cancellable and subject to immediate termination by the District upon the contractor’s insolvency, including the filing of proceedings in bankruptcy.

CHOICE-OF-LAW: The Agreement, any dispute, claim, or controversy relating to the Agreement, and all the rights and obligations of the parties shall, in all respects, be interpreted, construed, enforced and governed by and under the laws of the State of South Carolina, except its choice of law rules. As used in this paragraph, the term "Agreement" means any transaction or agreement arising out of, relating to, or contemplated by the solicitation.

CONTRACT AWARDED PURSUANT TO CODE: Any contract resulting from this solicitation is formed pursuant to the District's Procurement Code and is deemed to incorporate all applicable provisions thereof and the ensuing regulations. See also clause titled "Code of Laws Available."

CONTRACT DOCUMENTS & ORDER OF PRECEDENCE: (a) Any contract resulting from this solicitation shall consist of the following documents: (1) the solicitation, as amended, (2) your offer, as amended, (3) any statement reflecting the District's final acceptance (a/k/a "award"), and (4) purchase orders. These documents shall be read to be consistent and complementary. Any conflict among these documents shall be resolved by giving priority to these documents in the order listed above.

(b) The terms and conditions of documents (1) through (4) above shall apply notwithstanding any additional or different terms and conditions in any other document, including without limitation, (i) any instrument submitted by the District other than a purchase order, (ii) any invoice or other document submitted by Contractor, or (iii) any privacy policy, terms of use, or end user agreement. Except as otherwise allowed by the solicitation, the terms and conditions of all such documents and any purchase orders shall be void and of no effect.

(c) No contract, license, or other agreement containing contractual terms and conditions will be signed by the District. Any document signed or otherwise agreed to by persons other than the Procurement Officer shall be void and of no effect.

DISCOUNT FOR PROMPT PAYMENT: (a) Discounts for prompt payment will not be considered in the evaluation of offers. However, any offered discount will form a part of the award, and will be taken if payment is made within the discount period indicated in the offer by the Offeror. As an alternative to offering a discount for prompt payment in conjunction with the offer, Offerors awarded contracts may include discounts for prompt payment on individual invoices. (b) In connection with any discount offered for prompt payment, time shall be computed from the date of the invoice. If the Contractor has not placed a date on the invoice, the due date shall be calculated from the date the designated billing office receives a proper invoice, provided the District annotates such invoice with the date of receipt at the time of receipt. For the purpose of computing the discount earned, payment shall be considered to have been made on the date that appears on the payment check or, for an electronic funds transfer, the specified payment date. When the discount date falls on a Saturday, Sunday, or a legal holiday when Federal Government offices are closed and Government business is not expected to be conducted, payment may be made on the following business day.

DISPUTES: (1) Choice-of-Forum. All disputes, claims, or controversies relating to the Agreement shall be resolved exclusively by the appropriate Chief Procurement Officer in accordance with Title 11, Chapter 35, Article 17 of the South Carolina Code of Laws, or in the absence of jurisdiction, only in the Court of Common Pleas for, or a federal court located in, Richland County, State of South Carolina. Contractor agrees that any act by the government regarding the Agreement is not a waiver of either the government's sovereign immunity or the government's immunity under the Eleventh Amendment of the United States Constitution. As used in this paragraph, the term "Agreement" means any transaction or agreement arising out of, relating to, or contemplated by the solicitation. The government does not consent to the jurisdiction of any judicial or administrative tribunals in any other state or to any forum of alternative dispute resolution. (2) Service of Process. Contractor consents that any papers, notices, or process necessary or proper for the initiation or continuation of any disputes, claims, or controversies relating to the Agreement; for any court action in connection therewith; or for the entry of judgment on any award made, may be served on Contractor by certified mail (return receipt requested) addressed to Contractor at the address provided as the Notice Address on Page Two or by personal service or by any other manner that is permitted by law, in or outside South Carolina. Notice by certified mail is deemed duly given upon deposit in the United States mail.

EQUAL OPPORTUNITY: Contractor is referred to and shall comply with all applicable provisions, if any, of Title 41, Part 60 of the Code of Federal Regulations, including but not limited to Sections 60-1.4, 60-4.2, 60-4.3, 60-250.5(a), and 60-741.5(a), which are hereby incorporated by reference.

FALSE CLAIMS: According to the S.C. Code of Laws § 16-13-240, "a person who by false pretense or representation obtains the signature of a person to a written instrument or obtains from another person any chattel, money, valuable security, or other property, real or personal, with intent to cheat and defraud a person of that property is guilty" of a crime.

FIXED PRICING REQUIRED: Any pricing provided by contractor shall include all costs for performing the work associated with that price. Contractor's price shall be fixed for the duration of this contract, including option terms, except as otherwise provided in this solicitation. This clause does not prohibit contractor from offering lower pricing after award.

NO INDEMNITY OR DEFENSE: Any term or condition is void to the extent it requires the District to indemnify, defend, or pay attorney's fees to anyone for any reason.

NOTICE: (A) After award, any notices shall be in writing and shall be deemed duly given (1) upon actual delivery, if delivery is by hand, (2) upon receipt by the transmitting party of automated confirmation or answer back from the recipient's device if delivery is by telex, telegram, facsimile, or electronic mail, or (3) upon deposit into the United States mail, if postage is prepaid, a return receipt is requested, and either registered or certified mail is used. (B) Notice to contractor shall be to the address identified on Cover Page. Notice to the District shall be to the Procurement Officer's address on the Cover Page. Either party may designate a different address for notice by giving notice in accordance with this paragraph.

OPEN TRADE REPRESENTATION: During the contract term, including any renewals or extensions, Contractor will not engage in the boycott of a person or an entity based in or doing business with a jurisdiction with whom South Carolina can enjoy open trade, as defined SC Code Section 11-35-5300.

ORGANIZATIONAL CONFLICT OF INTEREST: (a) The Contractor agrees to immediately advise the Procurement Officer if an actual or potential organizational conflict of interest is discovered after award, and to make a full written disclosure promptly thereafter to the Procurement Officer. This disclosure shall include a description of actions which the Contractor has taken or proposes to take, after consultation with the Procurement Officer, to avoid, mitigate, or neutralize the actual or potential conflict.

(b) The District may terminate this contract for convenience, in whole or in part, if it deems such termination necessary to avoid an organizational conflict of interest. Contractor's failure to include an appropriate termination for convenience clause in any subcontract shall not increase the obligation of the District beyond what it would have been if the subcontract had contained such a clause.

(c) The disclosure required by paragraph (a) of this provision is a material obligation of the contract. If the Contractor knew or should have known of an organizational conflict of interest prior to award, or discovers an actual or potential conflict after award, and does not disclose, or misrepresents, relevant information to the Procurement Officer, the District may terminate the contract for default.

PAYMENT & INTEREST: (a) The District shall pay the Contractor, after the submission of proper invoices or vouchers, the prices stipulated in this contract for supplies delivered and accepted or services rendered and accepted, less any deductions provided in this contract. Unless otherwise specified herein, including the purchase order, payment shall not be made on partial deliveries accepted by the District. (b) Unless otherwise provided herein, including the purchase order, payment will be made by check mailed to the payment address on "page Two." (c) Notwithstanding any other provision, payment shall be made in accordance with S.C. Code Section 11-35-45, or Chapter 6 of Title 29 (real property improvements) when applicable, which provides the Contractor's exclusive means of recovering any type of interest from the Owner. Contractor waives imposition of an interest penalty unless the invoice submitted specifies that the late penalty is applicable. Except as set forth in this paragraph, the District shall not be liable for the payment of interest on any debt or claim arising out of or related to this contract for any reason. (d) Amounts due to the District shall bear interest at the rate of interest established by the South Carolina Comptroller General pursuant to Section 11-35-45 ("an amount not to exceed fifteen percent each year"), as amended, unless otherwise required by Section 29-6-30. (e) Any other basis for interest, including but not limited to general (pre- and post-judgment) or specific interest statutes, including S.C. Code Ann. Section 34-31-20, are expressly waived by both parties. If a court, despite this agreement and waiver, requires that interest be paid on any debt by either party other than as provided by items (c) and (d) above, the parties further agree that the applicable interest rate for any given calendar year shall be the lowest prime rate as listed in the first edition of the Wall Street Journal published for each year, applied as simple

interest without compounding. (f) The District shall have all of its common law, equitable and statutory rights of set-off.

PROHIBITION AGAINST CONFLICTS OF INTERESTS, GRATUITIES AND KICKBACKS: "Any employee or any official of the school district, elective or appointive, who shall take, receive or offer to take or receive either directly or indirectly, any rebate, percentage of contract, money or other things of value, as an inducement or intended inducement, in the procurement of business, or the giving of business, for, or to, or from, any person, partnership, firm of corporation, offering, bidding for, or in open market seeking to make sales to the school district shall be deemed guilty of a felony and upon conviction such person or persons shall be subject to punishment or a fine in accord with State and/or Federal laws."

PUBLICITY: Contractor shall not publish any comments or quotes from District employees, or include the District in either news releases or a published list of customers, without the prior written approval of the Procurement Officer.

PURCHASE ORDERS: CONTRACTOR SHALL NOT PERFORM ANY WORK PRIOR TO THE RECEIPT OF A PURCHASE ORDER FROM THE DISTRICT. The District shall order any supplies or services to be furnished under this contract by issuing a purchase order. Purchase orders may be used to elect any options available under this contract, e.g., quantity, item, delivery date, payment method, but are subject to all terms and conditions of this contract. Purchase orders may be electronic. No particular form is required. An order placed pursuant to the purchasing card provision qualifies as a purchase order. Purchase order number must be clearly stated on each carton or package, shipping ticket, invoice and any/all other information related to the order.

SURVIVAL OF OBLIGATIONS: The Parties' rights and obligations which, by their nature, would continue beyond the termination, cancellation, rejection, or expiration of this contract shall survive such termination, cancellation, rejection, or expiration, including, but not limited to, the rights and obligations created by the following clauses: Indemnification - Third Party Claims, Intellectual Property Indemnification, and any provisions regarding warranty or audit.

SWMBE PARTICIPATION: District Five of Lexington and Richland Counties encourages SWMBE businesses to participate in the Solicitation process. All business conducted with SWMBE businesses certified by the South Carolina Governor's Office of Small and Minority Business Assistance is recorded in an annual report submitted to the Board of Trustees. In order to be included in this report, you must submit a copy of your certificate with your bid.

TAXES: Any tax the contractor may be required to collect or pay upon the sale, use or delivery of the products shall be paid by the District, and such sums shall be due and payable to the contractor upon acceptance. Any personal property taxes levied after delivery shall be paid by the District. It shall be solely the District's obligation, after payment to contractor, to challenge the applicability of any tax by negotiation with, or action against, the taxing authority. Contractor agrees to refund any tax collected, which is subsequently determined not to be proper and for which a refund has been paid to contractor by the taxing authority. In the event that the contractor fails to pay, or delays in paying, to any taxing authorities, sums paid by the District to contractor, contractor shall be liable to the District for any loss (such as the assessment of additional interest) caused by virtue of this failure or delay. Taxes based on Contractor's net income or assets shall be the sole responsibility of the contractor.

TERMINATION: Subject to the conditions below, the District, providing a (30) thirty-day advance written notice is given to the vendor, may terminate the contract for any reason.

NON-APPROPRIATIONS: Any contract entered into by the District resulting from this bid invitation shall be subject to cancellation without damages or further obligation when funds are not appropriated or otherwise made available to support continuation of performance in a subsequent fiscal period or appropriated year.

FOR CONVENIENCE: In the event that this contract is terminated or canceled upon request and for the convenience of the District without the required thirty (30) days advance written notice, then the District may negotiate reasonable termination costs, if applicable.

FOR CAUSE: Termination by the District for cause, default or negligence on the part of the vendor shall be excluded from the foregoing conditions; termination costs, if any, shall not apply. The thirty (30) days advance notice requirement is waived and the default clause in this bid shall apply.

DEFAULT: In case of default by the vendor, the District reserves the right to purchase any or all items in default in the open market, charging the vendor with any additional costs. The defaulting vendor shall not be considered a responsible bidder until the assessed charge has been satisfied.

TERMINATION DUE TO UNAVAILABILITY OF FUNDS: Payment and performance obligations for succeeding fiscal periods shall be subject to the availability and appropriation of funds therefore. When funds are not appropriated or otherwise made available to support continuation of performance in a subsequent fiscal period, the contract shall be canceled. In the event of a cancellation pursuant to this paragraph, contractor will be reimbursed the resulting unamortized, reasonably incurred, nonrecurring costs. Contractor will not be reimbursed any costs amortized beyond the initial contract term.

THIRD PARTY BENEFICIARY: This Contract is made solely and specifically among and for the benefit of the parties hereto, and their respective successors and assigns, and no other person will have any rights, interest, or claims hereunder or be entitled to any benefits under or on account of this Contract as a third-party beneficiary or otherwise.

WAIVER: The District does not waive any prior or subsequent breach of the terms of the Contract by making payments on the Contract, by failing to terminate the Contract for lack of performance, or by failing to strictly or promptly insist upon any term of the Contract. Only the Procurement Officer has actual authority to waive any of District's rights under this Contract. Any waiver must be in writing.

VII. TERMS AND CONDITIONS – B. SPECIAL

1. The contractor shall furnish all labor, equipment, transportation, materials and supplies necessary to perform the work.
2. The contractor shall have all underground utilities located prior to beginning any work.
3. The contractor shall repair and return to their original state all turf areas damaged or disturbed by the contractor.
4. The contractor shall exercise precautions at all times for the protection and safety of their employees, school staff, students, and the general public. Barricades will be provided at the contractor's expense when work is performed in areas traversed by persons or vehicles or when deemed necessary by the District.
5. The contractor shall maintain workplace safety standards at all times.
6. SC law requires that contractors who are awarded contracts in excess of \$5,000 be licensed by the SC Contractors Licensing Board if required for the project. The contractor's SC General Contractor's license number must be clearly indicated on the face of the envelope of bids exceeding this amount. **Contractors must include a copy of their license(s) with their bid.**
7. The contractor shall coordinate installation of new service with Dominion Energy.

CHANGES:

(1) Contract Modification. By a written order, at any time, and without notice to any surety, the Procurement Officer may, subject to all appropriate adjustments, make changes within the general scope of this contract in any one or more of the following:

- (a) Drawings, designs, or specifications, if the supplies to be furnished are to be specially manufactured for the District in accordance therewith;
- (b) Method of shipment or packing;
- (c) Place of delivery;
- (d) Description of services to be performed;
- (e) Time of performance (i.e., hours of the day, days of the week, etc.); or,
- (f) Place of performance of the services.

Subparagraphs (a) to (c) apply only if supplies are furnished under this contract. Subparagraphs (d) to (f) apply only if services are performed under this contract.

(2) Adjustments of Price or Time for Performance. If any such change increases or decreases the contractor's cost of, or the time required for, performance of any part of the work under this contract, whether or not changed by the order, an adjustment shall be made in the contract price, the delivery schedule, or both, and the contract modified in writing accordingly. Any adjustment in contract price made pursuant to this clause shall be determined in accordance with the Price Adjustment Clause of this contract. Failure of the parties to agree to an adjustment shall not excuse the contractor from proceeding with the contract as changed, provided that the District promptly and duly make such provisional

adjustments in payment or time for performance as may be reasonable. By proceeding with the work, the contractor shall not be deemed to have prejudiced any claim for additional compensation, or an extension of time for completion.

(3) Time Period for Claim. Within 30 days after receipt of a written contract modification under Paragraph (1) of this clause, unless such period is extended by the Procurement Officer in writing, the contractor shall file notice of intent to assert a claim for an adjustment. Later notification shall not bar the contractor's claim unless the District is prejudiced by the delay in notification.

(4) Claim Barred After Final Payment. No claim by the contractor for an adjustment hereunder shall be allowed if notice is not given prior to final payment under this contract.

CISG: The parties expressly agree that the UN Convention on the International Sale of Goods shall not apply to this agreement.

COMPLIANCE WITH LAWS: During the term of the contract, contractor shall comply with all applicable provisions of laws, codes, ordinances, rules, regulations, and tariffs.

CONTRACTOR'S LIABILITY INSURANCE - GENERAL

(a) Without limiting any of the obligations or liabilities of Contractor, Contractor shall procure from a company or companies lawfully authorized to do business in South Carolina and with a current A.M. Best rating of no less than A: VII, and maintain for the duration of the contract, insurance against claims for injuries to persons or damages to property which may arise from or in connection with the performance of the work and the results of that work by the contractor, his agents, representatives, employees or subcontractors.

(b) Coverage shall be at least as broad as:

(1) Commercial General Liability (CGL): Insurance Services Office (ISO) Form CG 00 01 12 07 covering CGL on an "occurrence" basis, including products-completed operations, personal and advertising injury, with limits no less than \$1,000,000 per occurrence. If a general aggregate limit applies, the general aggregate limit shall be twice the required occurrence limit. This contract shall be considered to be an "insured contract" as defined in the policy.

(2) Auto Liability: ISO Form Number CA 00 01 covering any auto (Code 1), or if Contractor has no owned autos, hired, (Code 8) and non-owned autos (Code 9), with limits no less than \$1,000,000 per accident for bodily injury and property damage.

(3) Worker's Compensation: As required by the State of South Carolina, with Statutory Limits, and Employer's Liability Insurance with limit of no less than \$1,000,000 per accident for bodily injury or disease.

(c) The District, its officers, officials, employees and volunteers of any of them, must be covered as additional insureds on the CGL policy with respect to liability arising out of work or operations performed by or on behalf of the Contractor including materials, parts or equipment furnished in connection with such work or operations. General liability coverage can be provided in the form of an endorsement to the Contractor's insurance at least as broad as ISO Form CG 20 10 11 85 or if not available, through the addition of both CG 20 10 and CG 20 37 if a later edition is used.

(d) For any claims related to this contract, the Contractor's insurance coverage shall be primary insurance as respects the District, and the officers, officials, employees and volunteers of any of them. Any insurance or self-insurance maintained by the District, or the officers, officials, employees and volunteers of any of them, shall be excess of the Contractor's insurance and shall not contribute with it.

(e) Prior to commencement of the work, the Contractor shall furnish the District with original certificates and amendatory endorsements or copies of the applicable policy language effecting coverage required by this section. All certificates are to be received and approved by the District before work commences. However, failure to obtain the required documents prior to the work beginning shall not waive the Contractor's obligation to provide them. The District reserves the right to require complete, certified copies of all required insurance policies, including endorsements required by this section, at any time.

(f) Should any of the above-described policies be cancelled before the expiration date thereof, notice will be delivered in accordance with the policy provisions. In addition, the Contractor shall notify the District immediately upon receiving any information that any of the coverages required by this section are or will be changed, cancelled, or replaced.

(g) Contractor hereby grants to the District a waiver of any right to subrogation which any insurer of said Contractor may acquire against the District by virtue of the payment of any loss under such insurance. Contractor agrees to obtain any endorsement that may be necessary to effect this waiver of subrogation, but this provision applies regardless of whether or not the District or Using Governmental Unit has received a waiver of subrogation endorsement from the insurer.

(h) Any deductibles or self-insured retentions must be declared to and approved by the District. The District may require the Contractor to purchase coverage with a lower deductible or retention or provide proof of ability to pay losses and related investigations, claim administration, and defense expenses within the retention.

(i) The District reserves the right to modify these requirements, including limits, based on the nature of the risk, prior experience, insurer, coverage, or other special circumstances.

CONTRACTS: Every resulting contract is subject to all terms of the District procurement code including limitations as to duration, rights of the district to terminate and means of dispute resolution. No resulting contract is renewable except to the extent provided in the solicitation. No vendor terms take precedence over the solicitation and the District's procurement code.

CONTRACTOR PERSONNEL: The Contractor shall enforce strict discipline and good order among the Contractor's employees and other persons carrying out the Contract. The Contractor shall not permit employment of unfit persons or persons not skilled in tasks assigned to them.

CONTRACTOR'S OBLIGATION – GENERAL: The contractor shall provide and pay for all materials, tools, equipment, labor and professional and non-professional services, and shall perform all other acts and supply all other things necessary, to fully and properly perform and complete the work. The contractor must act as the prime contractor and assume full responsibility for any subcontractor's performance. The contractor will be considered the sole point of contact with regard to all situations, including payment of all charges and the meeting of all other requirements.

CONTRACTOR'S USE OF DISTRICT PROPERTY: Upon termination of the contract for any reason, the District shall have the right, upon demand, to obtain access to, and possession of, all District properties, including, but not limited to, current copies of all District application programs and necessary documentation, all data, files, intermediate materials and supplies held by the contractor. Contractor shall not use, reproduce, distribute, display, or sell any data, material, or documentation owned exclusively by the District without the District's written consent, except to the extent necessary to carry out the work.

DEFAULT – SHORT FORM: The District may terminate this contract, or any part hereof, for cause in the event of any default by the contractor, or if the contractor fails to comply with any material contract terms and conditions, or fails to provide the District, upon request, with adequate assurances of future performance. In the event of termination for cause, the District shall not be liable to the contractor for any amount for supplies or services not accepted, and the contractor shall be liable to the state for any and all rights and remedies provided by law. If it is determined that the District improperly terminated this contract for default, such termination shall be deemed a termination for convenience.

DISPOSAL OF PACKAGING: Contractor shall dispose of all wrappings, crating, and other disposable materials pertaining to this contract at the end of each working day and upon completion of installation.

ILLEGAL IMMIGRATION: (An overview is available at www.procurement.sc.gov) By signing your offer, you certify that you will comply with the applicable requirements of Title 8, Chapter 14 of the South Carolina Code of Laws and agree to provide to the District upon request any documentation required to establish either: (a) that Title 8, Chapter 14 is inapplicable to you and your subcontractors or sub-subcontractors; or (b) that you and your subcontractors or sub-subcontractors are in compliance with Title 8, Chapter 14. Pursuant to Section 8-14-60, "A person who knowingly makes or files any false, fictitious, or fraudulent document, statement, or report pursuant to this chapter is guilty of a felony, and, upon conviction, must be fined within the discretion of the court or imprisoned for not more than five years, or both." You agree to include in any contracts with your subcontractor's language requiring your subcontractors to (a) comply with the applicable requirements of Title 8, Chapter 14, and (b) include in their contracts with the sub-subcontractor's language requiring the sub-subcontractors to comply with the applicable requirements of Title 8, Chapter 14.

INDEMNIFICATION - THIRD PARTY CLAIMS - GENERAL: Notwithstanding any limitation in this agreement, and to the fullest extent permitted by law, Contractor shall defend and hold harmless indemnitees for and against any and all suits or claims of any character (and all related damages, settlement payments, attorneys' fees, costs, expenses, losses or liabilities) by a third party which are attributable to bodily injury, sickness, disease or death, or to injury to or destruction of tangible property arising out of or in connection with the goods or services acquired

hereunder or caused in whole or in part by any act or omission of contractor, its subcontractors, their employees, workmen, servants, agents, or anyone directly or indirectly employed by them or anyone for whose acts any of them may be liable, regardless of whether or not caused in part by an Indemnitee, and whether or not such claims are made by a third party or an Indemnitee; however, if an Indemnitee's negligent act or omission is subsequently determined to be the sole proximate cause of a suit or claim, the Indemnitee shall not be entitled to indemnification hereunder. Contractor shall be given timely written notice of any suit or claim. Contractor's obligations hereunder are in no way limited by any protection afforded under workers' compensation acts, disability benefits acts, or other employee benefit acts. This clause shall not negate, abridge, or reduce any other rights or obligations of indemnity which would otherwise exist. The obligations of this paragraph shall survive termination, cancelation, or expiration of the parties' agreement. This provision shall be construed fairly and reasonably, neither strongly for nor against either party, and without regard to any clause regarding insurance. As used in this clause, "Indemnitees" means District Five of Lexington and Richland Counties, its instrumentalities, agencies, departments, boards, and all their respective officers, agents and employees.

LICENSES AND PERMITS: During the term of the contract, the Contractor shall be responsible for obtaining, and maintaining in good standing, all licenses (including professional licenses, if any), permits, inspections and related fees for each or any such licenses, permits and /or inspections required by the State, county, city or other government entity or unit to accomplish the work specified in this solicitation and the contract.

MATERIAL AND WORKMANSHIP: Unless otherwise specifically provided in this contract, all equipment, material, and articles incorporated in the work covered by this contract are to be new and of the most suitable grade for the purpose intended.

PRICE ADJUSTMENTS: (1) Method of Adjustment. Any adjustment in the contract price made pursuant to a clause in this contract shall be consistent with this Contract and shall be arrived at through whichever one of the following ways is the most valid approximation of the actual cost to the Contractor (including profit, if otherwise allowed):

- (a) By agreement on a fixed price adjustment before commencement of the pertinent performance or as soon thereafter as practicable;
- (b) By unit prices specified in the Contract or subsequently agreed upon;
- (c) by the costs attributable to the event or situation covered by the relevant clause, including profit if otherwise allowed, all as specified in the Contract; or subsequently agreed upon;
- (d) in such other manner as the parties may mutually agree; or,
- (e) in the absence of agreement by the parties, through a unilateral initial written determination by the Procurement Officer of the costs attributable to the event or situation covered by the clause, including profit if otherwise allowed, all as computed by the Procurement Officer in accordance with generally accepted accounting principles, subject to the provisions of Title 11, Chapter 35, Article 17 of the S.C. Code of Laws.

(2) Submission of Price or Cost Data. Upon request of the Procurement Officer, the contractor shall provide reasonably available factual information to substantiate that the price or cost offered, for any price adjustments is reasonable, consistent with the provisions of Section 11-35-1830.

RELATIONSHIP OF THE PARTIES: Neither party is an employee, agent, partner, or joint venturer of the other. Neither party has the right or ability to bind the other to any agreement with a third party or to incur any obligation or liability on behalf of the other party.

SUBCONTRACTOR SUBSTITUTION PROHIBITED - RESIDENT SUBCONTRACTOR PREFERENCE:

If you receive an award as a result of the subcontractor preference, you may not substitute any business for the subcontractor upon which you relied to qualify for the preference, unless first approved in writing by the procurement officer. If you violate this provision, the District may terminate your contract for cause and you may be debarred. In addition, the procurement officer may require you to pay the District an amount equal to twice the difference between the price paid by the District and the price offered by the next lowest bidder, unless the substituted subcontractor qualifies for the preference.

TERMINATION FOR CONVENIENCE: (1) Termination. The Procurement Officer may terminate this contract

in whole or in part, for the convenience of the District. The Procurement Officer shall give written notice of the termination to the contractor specifying the part of the contract terminated and when termination becomes effective.

(2) Contractor's Obligations. The contractor shall incur no further obligations in connection with the terminated work and on the date set in the notice of termination the contractor will stop work to the extent specified. The contractor shall also terminate outstanding orders and subcontracts as they relate to the terminated work. The contractor shall settle the liabilities and claims arising out of the termination of subcontracts and orders connected with the terminated work. The Procurement Officer may direct the contractor to assign the contractor's right, title, and interest under terminated orders or subcontracts to the District. The contractor must still complete the work not terminated by the notice of termination and may incur obligations as are necessary to do so.

(3) Right to Supplies. The Procurement Officer may require the contractor to transfer title and deliver to the District in the manner and to the extent directed by the Procurement Officer: (a) any completed supplies; and (b) such partially completed supplies and materials, parts, tools, dies, jigs, fixtures, plans, drawings, information, and contract rights (hereinafter called "manufacturing material") as the contractor has specifically produced or specially acquired for the performance of the terminated part of this contract. The contractor shall, upon direction of the Procurement Officer, protect and preserve property in the possession of the contractor in which the District has an interest. If the Procurement Officer does not exercise this right, the contractor shall use best efforts to sell such supplies and manufacturing materials in accordance with the standards of Uniform Commercial Code Section 2-706. Utilization of this Section in no way implies that the District has breached the contract by exercise of the Termination for Convenience Clause.

(4) Compensation. (a) The contractor shall submit a termination claim specifying the amounts due because of the termination for convenience together with cost or pricing data required by Section 11-35-1830 bearing on such claim. If the contractor fails to file a termination claim within one year from the effective date of termination, the Procurement Officer may pay the contractor, if at all, an amount set in accordance with Subparagraph (c) of this Paragraph.

(b) The Procurement Officer and the contractor may agree to a settlement and that the settlement does not exceed the total contract price plus settlement costs reduced by payments previously made by the District, the proceeds of any sales of supplies and manufacturing materials under Paragraph (3) of this clause, and the contract price of the work not terminated;

(c) Absent complete agreement under Subparagraph (b) of this Paragraph, the Procurement Officer shall pay the contractor the following amounts, provided payments agreed to under Subparagraph (b) shall not duplicate payments under this Subparagraph:

(i) contract prices for supplies or services accepted under the contract;

(ii) costs reasonably incurred in performing the terminated portion of the work less amounts paid or to be paid for accepted supplies or services;

(iii) reasonable costs of settling and paying claims arising out of the termination of subcontracts or orders pursuant to Paragraph (2) of this clause. These costs must not include costs paid in accordance with Subparagraph (c)(ii) of this paragraph;

(iv) any other reasonable costs that have resulted from the termination. The total sum to be paid the contractor under this Subparagraph shall not exceed the total contract price plus the reasonable settlement costs of the contractor reduced by the amount of payments otherwise made, the proceeds of any sales of supplies and manufacturing materials under Subparagraph (b) of this Paragraph, and the contract price of work not terminated.

(d) Contractor must demonstrate any costs claimed, agreed to, or established under Subparagraphs (b) and (c) of this Paragraph using its standard record keeping system, provided such system is consistent with any applicable Generally Accepted Accounting Principles.

(5) Contractor's failure to include an appropriate termination for convenience clause in any subcontract shall not (i) affect the District's right to require the termination of a subcontract, or (ii) increase the obligation of the District beyond what it would have been if the subcontract had contained an appropriate clause.

VIII. BIDDING SCHEDULE

Vendor Name: _____

The bid price includes all work required by, and in strict accordance, with the bid documents, plans and specifications for this project.

| Description | Total Cost |
|---|------------|
| Install New Electrical Service for Marquee at Harbison West Elementary School 257 Crossbow Dr., Columbia, SC 29212 | \$ |

GRAND TOTAL (Basis of Award): \$ _____

Preferences: For a FAQ on these preferences, please see: <https://procurement.sc.gov/osp/preferences>

| QUESTION | RESPONSE |
|---|----------------|
| Are you requesting the Resident Contractor Preference- 7% ? <i>See the SC Procurement Code, Section 11-35-1524(C)(1)(iii)</i> | ___ YES ___ NO |
| Are you requesting the Resident Subcontractor Preference- 2% ? <i>See the SC Procurement Code, Section 11-35-1524(D)(1)&(2)</i> | ___ YES ___ NO |
| Are you requesting the Resident Subcontractor Preference- 4% ? <i>See the SC Procurement Code, Section 11-35-1524(D)(1)&(2)</i> | ___ YES ___ NO |

Signature of Authorized Official: _____

Print name and Title: _____

ATTACHMENTS TO SOLICITATION

LIST OF ATTACHMENTS

The following documents are attached to this solicitation:

- A. References
- B. Minority Participation Affidavit
- C. Offeror's Checklist
- D. Specifications/Drawings

ATTACHMENT A

REFERENCES

Instructions: Provide three references of customers that you have provided similar services as is described in this solicitation. The list of References shall be completed in its entirety and submitted with the bid response.

Company/School Name: _____

Address: _____

Contact Person: _____

Phone Number: _____

Email: _____

Type of Service: _____

Company/School Name: _____

Address: _____

Contact Person: _____

Phone Number: _____

Email: _____

Type of Service: _____

Company/School Name: _____

Address: _____

Contact Person: _____

Phone Number: _____

Email: _____

Type of Service: _____

ATTACHMENT B

MINORITY PARTICIPATION AFFIDAVIT

Is the bidder a South Carolina Certified Minority Business? Yes No

Is the bidder a Minority Business certified by another governmental entity? Yes No

If so, please list the certifying governmental entity: _____

Will any of the work under this contract be performed by a SC certified Minority Business as a subcontractor? Yes No

If so, what percentage of the total value of the contract will be performed by a SC certified Minority Business as a subcontractor? _____

Will any of the work under this contract be performed by a minority business certified by another governmental entity as a subcontractor? Yes No

If so, what percentage of the total value of the contract will be performed by a minority business certified by another governmental entity as a subcontractor? _____

If a certified Minority Business is participating in this contract, please indicate all categories for which the Business is certified:

- Traditional minority
- Traditional minority, but female
- Women (Caucasian females)
- Hispanic minorities
- DOT referral (Traditional minority)
- DOT referral (Caucasian female)
- Temporary certification
- SBA 8 (a) certification referral
- Other minorities (Native American, Asian, etc.)

(If more than one minority contractor will be utilized in the performance of this contract, please provide the information above for each minority business.)

The Department of Administration, Division of Small and Minority Business Contracting and Certification, publishes a list of certified minority firms. The Minority Business Directory is available at the following URL: <http://osmba.sc.gov/directory.html>
[04-4015-3]

ATTACHMENT C
Offeror's Checklist

OFFEROR'S CHECKLIST

AVOID COMMON BID/PROPOSAL MISTAKES

Review this checklist prior to submitting your bid/proposal.

If you fail to follow this checklist, you risk having your bid/proposal rejected.

- ✓ COMPLETED & SIGNED ALL REQUIRED DOCUMENTS.
- ✓ DO NOT INCLUDE ANY OF YOUR STANDARD CONTRACT FORMS!
- ✓ UNLESS EXPRESSLY REQUIRED, DO NOT INCLUDE ANY ADDITIONAL BOILERPLATE CONTRACT CLAUSES!
- ✓ REREAD YOUR ENTIRE BID/PROPOSAL TO MAKE SURE YOUR BID/PROPOSAL DOES NOT TAKE EXCEPTION TO ANY OF THE DISTRICT'S MANDATORY REQUIREMENTS!
- ✓ MAKE SURE YOU HAVE PROPERLY MARKED ALL PROTECTED, CONFIDENTIAL OR TRADE SECRET INFORMATION IN ACCORDANCE WITH THE INSTRUCTIONS: "SUBMITTING CONFIDENTIAL INFORMATION." DO NOT MARK YOUR ENTIRE RESPONSE AS CONFIDENTIAL, TRADE SECRET OR PROTECTED! DO NOT INCLUDE A LEGEND ON THE COVER STATING THAT YOUR ENTIRE RESPONSE IS NOT TO BE RELEASED!
- ✓ HAVE YOU PROPERLY ACKNOWLEDGED ALL AMENDMENTS? INSTRUCTIONS REGARDING HOW TO ACKNOWLEDGE AN AMENDMENT SHOULD APPEAR IN ALL AMENDMENTS ISSUED.
- ✓ MAKE SURE THAT YOUR BID/PROPOSAL INCLUDES A COPY OF THE SOLICITATION COVER PAGE. MAKE SURE THE COVER PAGE IS SIGNED BY A PERSON THAT IS AUTHORIZED TO CONTRACTUALLY BIND YOUR BUSINESS.
- ✓ MAKE SURE YOUR BID/PROPOSAL INCLUDES THE NUMBER OF COPIES REQUESTED.
- ✓ CHECK TO ENSURE YOUR OFFER INCLUDES EVERYTHING REQUESTED!
- ✓ IF YOU HAVE CONCERNS ABOUT THE SOLICITATION, DO NOT RAISE THOSE CONCERNS IN YOUR RESPONSE! **AFTER OPENING, IT IS TOO LATE! IF THIS SOLICITATION INCLUDES A QUESTION & ANSWER PERIOD OR A PRE-SOLICITATION CONFERENCE, RAISE YOUR QUESTIONS AS PART OF THAT PROCESS!** PLEASE SEE INSTRUCTIONS UNDER THE HEADING "SUBMISSION OF QUESTIONS" AND ANY PROVISIONS REGARDING PRE-BID/PROPOSAL CONFERENCES.

This checklist is included only as a reminder to help offerors avoid common mistakes. Responsiveness will be evaluated against the solicitation, not against this checklist. You do not need to return this checklist with your offer.

SUBMIT WITH OFFER:

1. Cover Page
2. Page 2
3. Bid Schedule
4. Reference Sheet
5. Minority Participation Affidavit
6. Completed W-9
7. Copy of License(s), if applicable
8. Certificate of Insurance (COI)

ATTACHMENT D-SPECIFICATIONS-DRAWINGS

ELECTRICAL SPECIFICATIONS

- GENERAL PROVISIONS**
 - Work included in these specifications and included on the drawings shall include furnishing all labor, materials, supplies, and equipment to perform all work required including cutting, excavating and backfilling, to install a complete and working electrical system(s) in accordance with these sections of the specifications and the accompanying drawings. This shall include all required preparation work, raceways, coordination, etc. required to install the electrical system.
 - The electrical work shall include, but in no way be limited to the following:
 - Raceways (To include raceways for conductors and cables, but also employ for designated signal systems and future uses.)
 - Electrical Distribution System
 - Exterior and Interior Lighting Systems.
 - Exterior and Interior Power Systems.
 - Wiring Devices.
 - Connection and Installation of Equipment Furnished Under Other Divisions of the Specification.
 - Utility Service Entrances - Electrical
 - The contractor is responsible for including any and all work related to the electrical that is noted in any part of the specifications or any part of the drawings, including Divisions 1, 15 and any other sections. The contractor will supply power to equipment at the voltage indicated on the drawings. The contractor will be held responsible for coordinating the equipment voltages, control equipment, wiring, and locations and type of terminations/connections and/or disconnects to comply with the National Electrical Code, International Building Code, International Energy Conservation Code, all local codes, and the equipment manufacturer's requirements.
 - Electrical Drawings are diagrammatic in nature except where specific dimensions, or specific details are shown on the electrical, mechanical, or architectural drawings. The contractor shall refer to other drawings for exact locations of equipment, building dimensions, architectural details and conditions affecting the electrical work, however, field measurements take precedence over dimensioned drawings. The Electrical Contractor shall provide all labor and materials and all incidental elements, junction and pull boxes, filters, pull wires, connectors, support materials, fuses, disconnect switches, lamps, and labels, to install, connect, start-up and result in a complete and working system in accordance with the drawings and specifications. The contractor is responsible for coordinating the installation of all electrical work with the work of other contractors and/or trades. The electrical drawings are such that the electrical service to equipment furnished and installed under other sections of the contract documents (examples, include but are not limited to: HVAC equipment, water heaters, fans, pumps, motors, etc.) is coordinated for the electrical work only. If the equipment installed under other divisions of the contract documents is not the specified equipment it is the responsibility of the contractor to coordinate the electrical service/interface requirements with the electrical contractor.
 - Provide all wiring, connectors, fittings, connections, and all accessories for the complete installation of, and final connections to, equipment furnished under other divisions of the specifications and where indicated on the drawings or otherwise specified.
 - All safety disconnect switches shall be provided under Division 16 unless specifically noted on drawings. The electrical contractor shall furnish and install fuses that are sized in accordance to the equipment nameplate of the equipment served.
 - The contractor is responsible for obtaining all required permits and complying with all National (NEC, IBC, NFPA), State, County, and Municipal codes and regulations. This shall include, but not be limited to, the following:
 - Federal Occupational Safety and Health Act (OSHA)
 - NFPA 70 (National Electrical Code)
 - NFPA 101 (Life Safety Code)
 - Americans with Disabilities Act (ADA)
 - International Building Code (IBC)
 - International Energy Conservation Code (IECC)
 - The contractor shall keep a set of construction drawings during the length of the project on which he shall note any and all changes from the original drawings. This record set of drawings shall be updated daily.
 - Electrical Subcontractor shall submit for review by the Engineer detailed shop drawings of all material listed below. All submittal data shall be submitted at one time. No material or equipment for which Engineer's review is required shall be delivered to the job site or installed until the Electrical Contractor has in his possession the reviewed and approved shop drawings for the particular material and/or equipment. The Electrical Contractor shall assemble, organize, prepare and review for correctness shop drawings on all materials, equipment, fixtures and devices to be used. If material submitted is the result of "value engineering" or "prior approval" changes, the submittal must contain supporting documentation of the approved changes, otherwise it will be reviewed against the specified products on these plans. The Electrical Contractor shall furnish one (1) PDF copy of shop drawings. Shop drawings that are incorrectly submitted, contain errors or omissions, or not in the form and sequence specified shall be rejected as unapproved. Shop drawings shall contain as cover page a letter by the supplying Vendor stating that the Vendor has received full contract documents and that to the best of his or her knowledge the submittal is in compliance with the contract documents and design intent including all ancillary parts and pieces required for a complete job. Review of shop drawings in no way relieves the Contractor of his responsibility of quantity, dimensions, weights, means and methods, safety, or coordination with others. Failure of the Contractor to submit shop drawings to the Engineer with reasonable time for review shall not entitle the Contractor to an extension of contract time. Reasonable review time is fifteen working days unless otherwise specified. At minimum shop drawings shall be submitted for
 - Panelboards
 - SPD's
 - Basic materials; wire, conduit, fittings, wiring devices
- Requests for Substitution**

Substitution Requests must be received electronically to DBSids@lexrich5.org by the deadline noted in the District's solicitation document. Substitution requests shall contain cut sheets, catalog numbers, the manufacturer's published description, or other descriptive document, explaining in detail exactly what is being proposed. Requests shall include adequate photometric and energy use documentation for comparison to specified. The District shall reserve the exclusive right to determine products and/or services which are approved as equal to those specified in the solicitation. Substituted items will not result in an increase in cost to the Owner.
- Catalog numbers and names that appear in the specifications or on the plans may be incomplete or obsolete and are for descriptive purposes only. As such they may not indicate all of the parts, pieces and systems required for a complete and operating installation. It is the responsibility of the Electrical Contractor, the Vendor and the Supplier to review the plans, specifications and applications to determine the correct item(s) required to include all installation and support materials and systems for a complete and working installation.**

- RACEWAYS/CONDUITS AND ASSOCIATED EQUIPMENT**
 - The work shall include all raceways, conduits, fittings, and all other equipment required to install a raceway system. This shall include, but not be limited to the following:
 - Rigid metal conduit and fittings.
 - Electrical metallic tubing and fittings.
 - Flexible metal conduit and fittings.
 - Liquid tight flexible metal conduit and fittings.
 - Non-metallic conduit and fittings.
 - Except where otherwise permitted on drawings route all conductors in conduit.
 - All signal systems shall have their wiring installed in conduit/raceways to above accessible ceiling. All cabling exposed above ceiling shall be plenum rated.
 - Conduit routing and device wiring for signal system components is not shown on the drawings. The contractor shall coordinate with the signal system manufacturer to determine the conduit (size and routing) and wiring requirements to circuit the equipment shown on the drawings.
 - Specified products and their areas of use shall be as described on drawings.
 - Fittings shall be steel compression type, concrete tight for all EMT raceways. For PVC raceways, use slip fittings with glue joints. For rigid galvanized steel and IMC, fittings shall be threaded galvanized iron, heavy steel, concrete tight.
 - Size conduit for conductor type installed; 1/2 inch minimum size.
 - For all empty raceways, furnish and install a nylon pull cord. The nylon pull cord shall be rated for a 200 pound force pull strength.
- WIRE AND CABLE - 600 VOLTS AND LESS**
 - Work shall include the furnishing and installing of all required wire and cable to complete the wiring and electrical system. This shall include, but not be limited to the following:
 - Building wire.
 - Wiring connections and terminations.
 - All service entrance power cable shall be type XHHW OR THWN-2, 90 degree C, copper conductor U.N.O. Feeders and Branch Circuits Larger Than 8 AWG: Copper, stranded conductor, 600 volt insulation, THHN. Feeders and Branch Circuits 8 AWG and Smaller: Copper conductor, 600 volt insulation, THHN. 6 and 8 AWG, stranded conductor smaller than 8 AWG, solid conductor. MINIMUM SIZE SHALL BE #12 FOR ALL WIRING ABOVE 48 VOLTS. All conductors in damp or wet locations (including below grade) shall be listed for that use, THWN-2 or equivalent.
 - All cables shall be color coded. Color coding shall be as follows:

| | |
|--------------|---------|
| 120/208 Volt | Phase |
| Black | A |
| Red | B |
| White | Neutral |
| Green | Ground |
 - Each wire or cable in a feeder at its terminal points, and in each pull-box, junction box, and panel gutter through which it passes shall be identified to show the circuit number of the breaker that it connects to. Each common wire, common circuit to common loop of a system, sound system, or any signal system conductor, shall be identified.
 - All installation shall be in accordance with the NEC. All splices shall be in junction boxes and shall be electrically and mechanically secure. Where a circuit home run is shown on the plans without any conductor or raceway identification, it shall be a minimum of 2 # 12, 1 # 12 Ground, 1/2" Conduit. Place an equal number of conductors for each phase of a circuit in same raceway or cable. Splice only in junction or outlet boxes. Neatly train and lace within cabinet base plates and covers. Hinge pins, springs and screws shall be constructed of stainless steel. Covers shall comply with appropriate UL and NEC requirements for use in wet locations.
- WIRING DEVICES**
 - The shall include the furnishing and installing of any and all wiring devices required to make a complete and functioning wiring system. See the drawings for symbols and descriptions of devices. Wiring devices are to establish a level of quality. All devices shall be best specification grade. Equivalent devices by Pass and Seymour or Leviton are acceptable. Color of devices shall be per Architect.
 - Duplex receptacle shall be 20 ampere, 120 volt, 2-Pole, 3-Wire, NEMA 5-20R. Unit shall be HBL #5362 or HBL #5362TR (where required).
 - Ground Fault receptacle shall be HBL #GF5362 or HBL #GF5362TR (where required).
 - Light switches other than sweep switches and low voltage button stations shall be 20 ampere, 120-277 volt. Unit shall be HBL #1221 for SPST, HBL #1223 for three-way, and HBL #1224 for Four-Way.
 - Installation shall be per NEC. Include ground wire and connection with all receptacle circuits. Quadraplex receptacles shall be two duplex receptacles installed in a two gang box. Install wall boxes OFF position down. Install convenience receptacles grounding pole on top. Install devices and wall plates flush and level. Provide GFCI receptacles within 5' of any water source. GFCI receptacles shall not be used to protect non-GFCI receptacles.
 - Wiring Device Plates:
 - Provide over-sized Thermoset type cover plates for all flush mounted devices. Color shall match existing or provide at minimum selection of white, ivory, brown or gray.
 - Plates for surface mounted devices in unfinished areas shall be steel, galvanized types with beveled edges.
 - Screws securing the plate shall have flush mounted heads (when installed) with finish to match that of the plate.
 - Weather-proof plates shall be constructed with cast aluminum base plates and covers. Hinge pins, springs and screws shall be constructed of stainless steel. Covers shall comply with appropriate UL and NEC requirements for use in wet locations.

- PANELBOARDS**
 - This section includes furnishing and installing panelboards and related equipment to form a complete and functioning electrical system. This shall include, but not be limited to the following:
 - Service and distribution panelboards.
 - Lighting and appliance branch circuit panelboards.
 - Panelboards shall be as manufactured by Square D or approved alternate.
 - Provide cabinet front with concealed trim clamps, and hinged door with flush lock. Finish in manufacturer's standard gray enamel. Provide panelboards with bus ratings as schedule. Provide ground bus in all panelboards. Minimum Integrated Short Circuit Rating. See drawings. Molded Case Circuit Breakers: NEMA AB 1; provide circuit breakers with integral thermal and instantaneous magnetic trip in each pole. Provide circuit breakers UL listed as Type HACR for air conditioning equipment branch circuits.
 - Furnish and install all required materials to install and mount the panelboards to the wall shown on the drawings. Install panelboards plumb and flush with wall finishes, in conformance with NEMA PB 1.1. Provide filler plates for unused spaces in panelboards.
 - Provide typed circuit directory for each circuit breaker in each panelboard. Visual and Mechanical Inspection: Inspect for physical damage, proper alignment, anchorage, and grounding. Check proper installation and tightness of connections for circuit breakers, fusible switches, and fuses. Provide name plates for each panel and switch as described in the General Notes on the drawings.
- SECONDARY GROUNDING**
 - Work included shall include power system grounding, communication system grounding, and electrical equipment and raceway grounding and bonding. Ground electrical work in accordance with NEC Article 250, local codes as specified herein, and as shown on the drawings.
 - Ground the electrical service system neutral at service entrance to metallic water service and to supplementary grounding electrode(s). Provide communications system grounding conductor at point of service entrance. Bond together system neutrals, service equipment enclosures, exposed non-current carrying metal parts of electrical equipment, metal raceway systems, grounding conductor in raceways and cables, receptacle ground connectors, and plumbing systems.
 - Provide a grounding system that includes all connections and testing of: ground rods, ground cables, ground buses, conduits, fittings, anchors, CADWELD(R) materials and equipment, and other materials as required for a complete installation. Provide ground cables composed of soft drawn, stranded bare copper of 98 percent conductivity encased in nonmetallic conduit above grade. Cable to be buried not less than 24 inches below grade. Install as required to provide sufficient mechanical protection. All copper to copper and copper to steel connections of #6 AWG and larger shall be made with the CADWELD(R).
 - Ground Rods: Copper-encased steel, 3/4 inch diameter, minimum length 10 feet. Number as required to achieve 10 ohms maximum.
 - Provide a separate, insulated equipment grounding conductor in feeder and branch circuits. Terminate each end on a grounding lug, bus, or bushing. Connect grounding electrode conductors to metal water pipe using a suitable ground clamp. Make connections to flanged piping at street side of flange. Provide bonding jumper around water meter. Supplementary Grounding Electrode: Use driven ground rod on exterior of building.
 - Install ground cables continuous between connections. Splices will not be allowed except where indicated on the drawings. Connections made by the CADWELD(R) Process are not considered splices. Where ground cables pass through floor slabs, building walls, etc., and are not in metallic enclosures, provide the sleeves of approved nonmetallic material.
 - Install equipment grounding conductors in raceway with feeder and branch circuit conductors. Flexible metal conduit shall have a ground wire installed with the power conductors. Where connections are made to motors or equipment with flexible metal conduit, grounding conductor shall be stranded copper conductor within the conduit, bonded to the equipment and to the rigid metal raceway system.
 - TESTING**
 - GUARANTEE OF WORK, EQUIPMENT AND MATERIALS**
 - The complete system shall be free of faults, short circuits, grounds and open circuits. Balance loads across phases to obtain minimum neutral current in feeders and branch circuits.
 - The Electrical Contractor shall perform inspections and test as herein specified. The Electrical Contractor shall provide all material, equipment, labor and supervision to perform such tests and inspections.
 - It is the intent of these tests to assure that all tested electrical equipment and systems are operational and within industry and the manufacturer's tolerances and is installed in accordance with the design Specifications. The test and inspections shall determine suitability for energization. Written documentation of the tests and inspections shall be provided and shall include the company name performing the work, project name, date and time of tests, weather and humidity.
 - Systems and equipment are to be tested and operated to verify compliance with the requirements of the contract documents and applicable codes. Equipment, systems, conductors and devices to be tested are as follows:
 - Power Distribution Equipment shown on the one-line (Power Riser) diagram.
 - Proper torque values on lugs and connectors.
 - Proper operation of equipment ground fault protective devices.
 - Conductors - Conductors rated 100 amperes and above.
 - Proper conductor and insulation type
 - Insulation resistance test (Megger) at 1000 volts DC for 1 minute or per cable manufacturer specifications.
 - Minimum insulation resistance values shall not be less than fifty (50) megohms.
 - Grounding
 - Test ground resistance using the attached rod technique (ART) or the fall of potential method according to IEEE 81 at the service entrance.
 - Verify proper type and size of grounding conductors and proper ground connections.
 - If ground resistance exceeds 10 ohms or values otherwise specified in the Specifications, equipment requirements or General or Special Conditions notify the Engineer immediately. The Electrical Contractor shall be responsible for providing alternate and/or additional means of grounding to reduce the ground resistance to 10 ohms or below at no additional cost.
 - All devices which must be adjusted or set to operate on a schedule (time clocks, program mechanisms, etc.) shall be set prior to substantial completion to operate on schedules directed by the Owner. Instruct the owner on the proper operation of these devices.

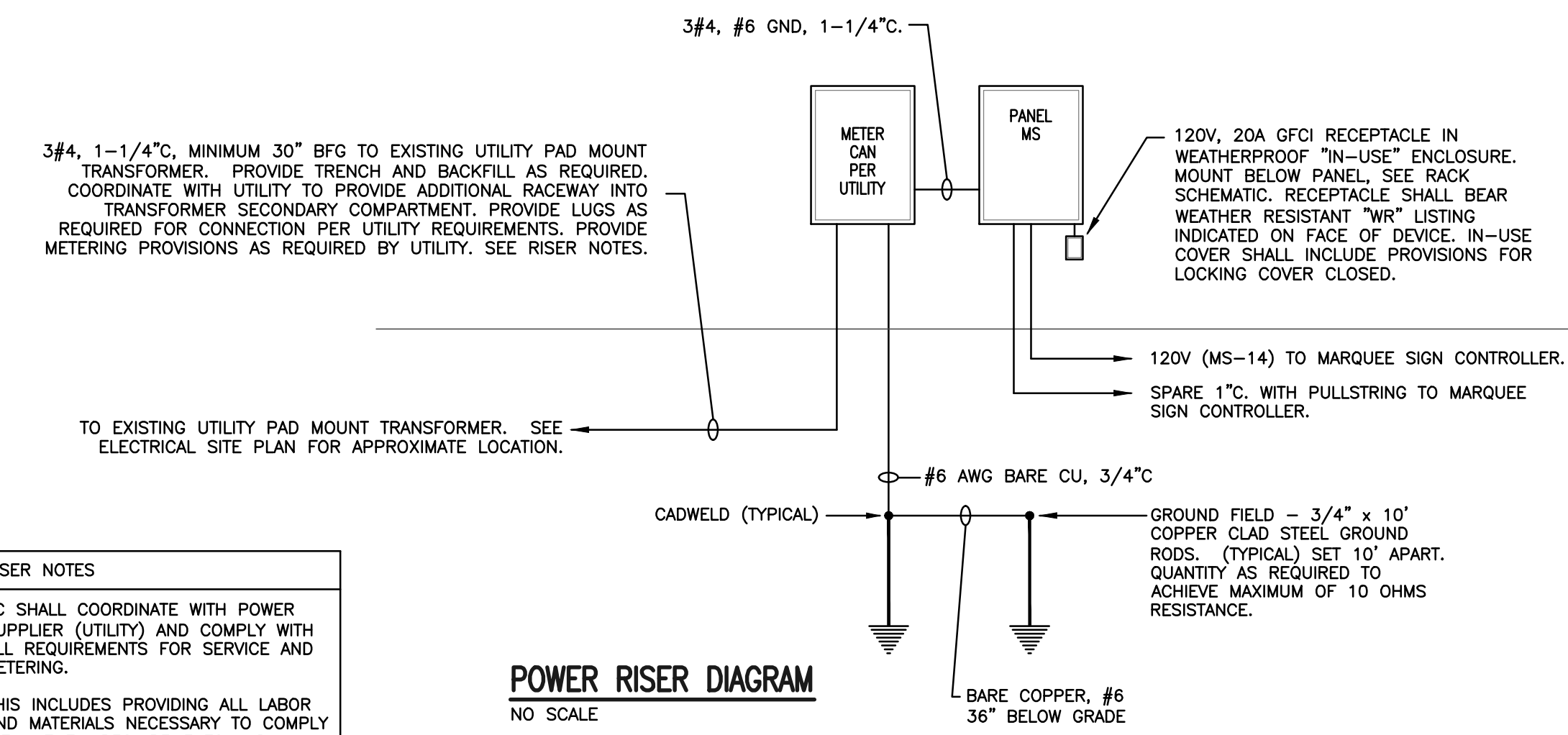

RISER NOTES

EC SHALL COORDINATE WITH POWER SUPPLIER (UTILITY) AND COMPLY WITH ALL REQUIREMENTS FOR SERVICE AND METERING.

THIS INCLUDES PROVIDING ALL LABOR AND MATERIALS NECESSARY TO COMPLY WITH UTILITY REQUIREMENTS AND COORDINATION WITH THE UTILITY TO DETERMINE SERVICE POINT LOCATION AND TYPE.

UTILITY PROVIDER: DOMINION ENERGY CONTACT: TIM ADAMS 803-217-8589

MEASURE RESISTANCE TO GROUND PRIOR TO ENERGIZATION OF EQUIPMENT. IF RESISTANCE TO GROUND IS GREATER THAN 10 OHMS, PROVIDE ALL MATERIALS AND WORK REQUIRED TO REDUCE RESISTANCE TO LESS THAN 10 OHMS AT NO INCREASED COST TO OWNER.

A/C RATINGS ARE BASED ON A 100KVA PAD MOUNTED UTILITY TRANSFORMER WITH 2.82% IMPEDANCE, 120/240V LOCATED 200' FROM SERVICE ENTRANCE WITH AVAILABLE SHORT CIRCUIT CURRENT OF 1,987 AMPS LINE TO GROUND AND 1,092 AMPS LINE TO LINE SERVICE ENTRANCE GEAR.

ALL SERVICE EQUIPMENT SHALL BE LABELED PER NEC 110.16, 110.21 AND 110.24.

ALL UNDERGROUND RACEWAYS SHALL BE IDENTIFIED BY UNDERGROUND LINE MARKING TAPE LOCATED DIRECTLY ABOVE THE RACEWAY AT 6" TO 8" BELOW FINISHED GRADE. TAPE SHALL BE PERMANENT, BRIGHTLY COLORED, CONTINUOUS PRINTED, PLASTIC TAPE COMPOUNDED FOR DIRECT BURIAL NOT LESS THAN 4" WIDE AND 4 MILS THICK. PROVIDE #12 COPPER/CLAD STEEL (CSS) TRACER WIRE WITH A DURABLE DIRECT-BURIED-RATED INSULATION, CONTINUOUS FROM END-TO-END OF SERVICE FEEDER.

CONNECTED LOAD, THIS SECTION (KVA): 1.8

* VERIFY WITH OWNER PROVIDED EQUIPMENT REQUIREMENTS.
** OR AS REQUIRED BY EQUIPMENT BEING INSTALLED.

| | |
|-----|--------------------|
| SPD | SQUARE D Q0250PSPD |
|-----|--------------------|

| NO. | CIRCUIT NAME | WIRE | CONDUIT | LOAD | TRIPS | TRIP TEST | TRIP TEST | TRIP TEST | TRIP TEST | TRIP TEST | TRIP TEST | TRIP TEST | TRIP TEST | TRIP TEST | TRIP TEST | TRIP TEST | TRIP TEST | TRIP TEST | TRIP TEST | |
|-----|----------------|------|---------|------|-------|-----------|-----------|-----------|-----------|-----------|-----------|-----------|-----------|-----------|-----------|-----------|-----------|-----------|-----------|--|
| 1 | PREPARED SPACE | | | | | | | | | | | | | | | | | | | |
| 2 | PREPARED SPACE | | | | | | | | | | | | | | | | | | | |
| 3 | PREPARED SPACE | | | | | | | | | | | | | | | | | | | |
| 4 | PREPARED SPACE | | | | | | | | | | | | | | | | | | | |
| 5 | PREPARED SPACE | | | | | | | | | | | | | | | | | | | |
| 6 | PREPARED SPACE | | | | | | | | | | | | | | | | | | | |
| 7 | PREPARED SPACE | | | | | | | | | | | | | | | | | | | |
| 8 | PREPARED SPACE | | | | | | | | | | | | | | | | | | | |
| 9 | PREPARED SPACE | | | | | | | | | | | | | | | | | | | |
| 10 | PREPARED SPACE | | | | | | | | | | | | | | | | | | | |
| 11 | PREPARED SPACE | | | | | | | | | | | | | | | | | | | |
| 12 | PREPARED SPACE | | | | | | | | | | | | | | | | | | | |
| 13 | PREPARED SPACE | | | | | | | | | | | | | | | | | | | |
| 14 | PREPARED SPACE | | | | | | | | | | | | | | | | | | | |
| 15 | SPD | | | | | | | | | | | | | | | | | | | |

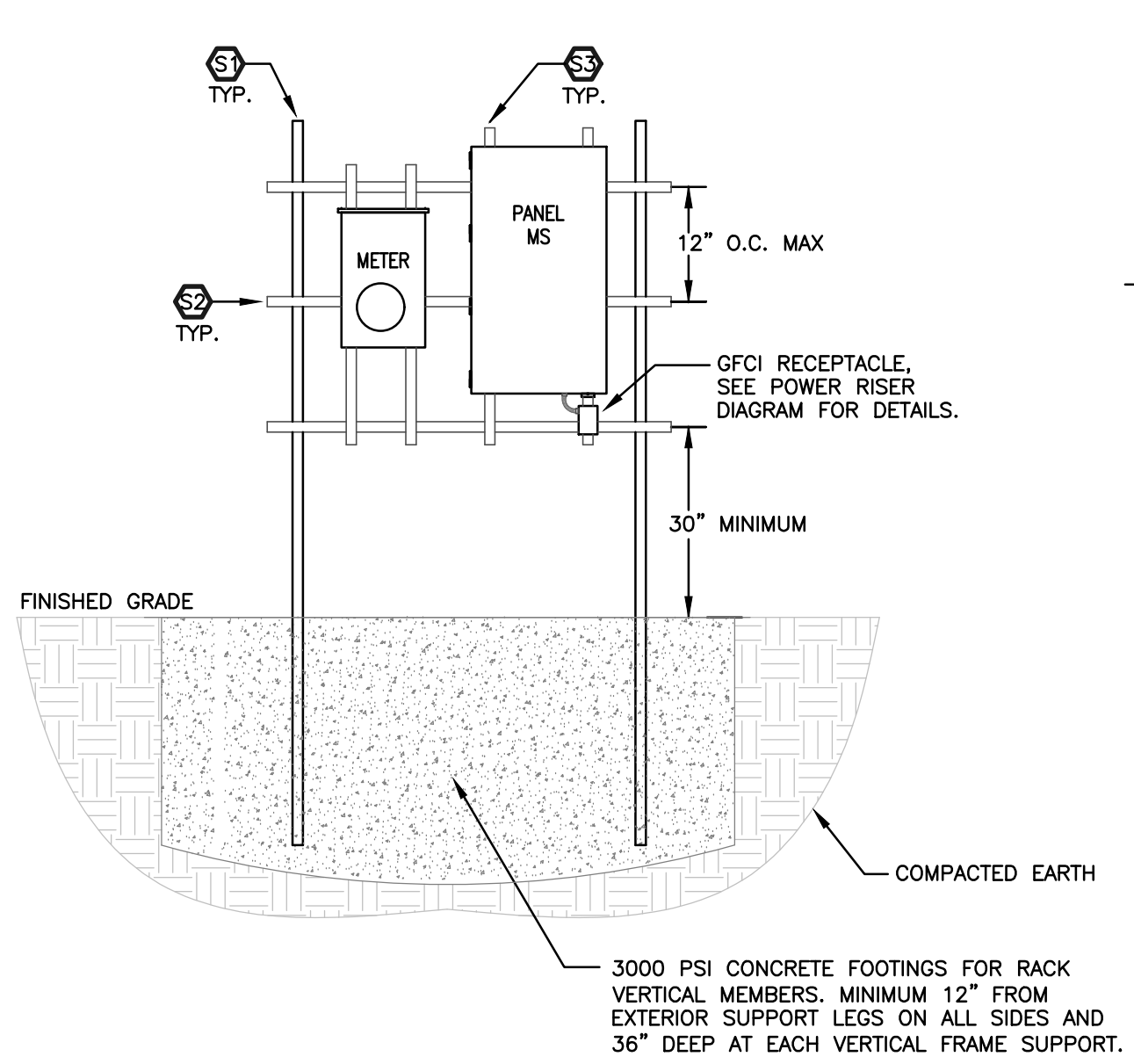

- EQUIPMENT RACK FRAME LEGEND:**
- VERTICAL RACK FRAME MEMBERS (TYPICAL OF 2): PROVIDE MINIMUM 3" GALVANIZED CONDUIT FILLED WITH CONCRETE AND CAPPED FOR ALL VERTICAL RACK SUPPORTS. USE GALVANIZED FASTENERS, STRAPS, FITTINGS, ETC ONLY. COAT ALL FIELD CUTS OF SUPPORTS OR HARDWARE WITH COLD GALVANIZING SPRAY.
 - MAIN HORIZONTAL RACK MEMBERS (TYPICAL OF 3): 12 GAUGE HOT-DIPPED GALVANIZED UNSTRUT, 1-5/8" CHANNEL x 1-5/8" DEPTH, 1-1/8" x 9/16" SLOTS ON 2" CENTERS.
 - VERTICAL RACK EQUIPMENT SUPPORTS (TYPICAL FOR ALL RACK MOUNTED EQUIPMENT): 12 GAUGE HOT-DIPPED GALVANIZED UNSTRUT, 1-5/8" CHANNEL x 1-5/8" DEPTH, 1-1/8" x 9/16" SLOTS ON 2" CENTERS. LENGTHS AS REQUIRED TO SECURE TO HORIZONTAL RACK FRAME MEMBERS ABOVE, BELOW AND BEHIND ALL EQUIPMENT.
- GENERAL NOTE FOR EQUIPMENT MOUNTING:**
COORDINATE EXACT LOCATION OF RACK WITH OWNER. MAINTAIN ELECTRICAL CLEARANCES AND WORKING SPACE AND ACCESS IN ACCORDANCE WITH THE NEC FOR ALL EQUIPMENT INSTALLATIONS.

RACEWAY MATERIAL SCHEDULE

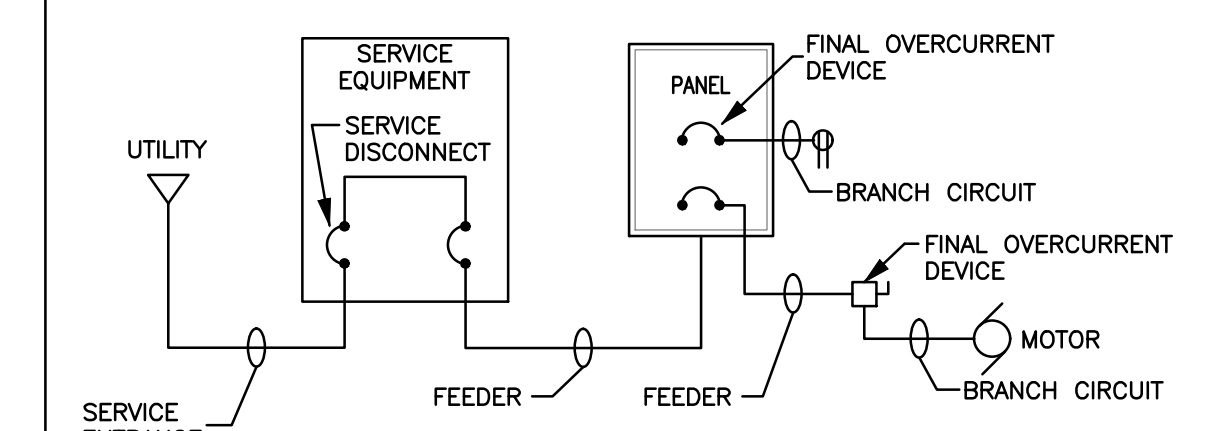

- RACEWAY MATERIALS:**
- SERVICE ENTRANCE: IMC, GRS, SCHED 40 PVC (WITH GRS 90 EMBOWED). IMC AND GRS TO HAVE BITUMINOUS COATING IF INSTALLED BELOW GRADE.
- SERVICE ENTRANCE WHERE EXPOSED TO PHYSICAL DAMAGE OR ABOVE GRADE: IMC, GRS, SCHEDULE 80 PVC.
- FEEDERS: GRS EXCEPT WHERE OTHERWISE NOTED
- OUTDOORS BELOW GRADE: SAME AS SERVICE ENTRANCE.
- OUTDOORS EXPOSED: IMC, GRS (WITH THE EXCEPTION OF CONNECTIONS TO MECHANICAL EQUIPMENT WHICH MAY BE FLEXIBLE WATER TIGHT CONDUIT).
- CONNECTIONS TO ENCLOSURES SHALL ONLY BE PERMITTED ON SIDES OR BOTTOM OF ENCLOSURES. PROVIDE WATER TIGHT HUBS (MYERS HUBS OR EQUIVALENT) FOR ALL CONNECTIONS TO ENCLOSURES.

| ABBREVIATIONS | | | |
|---------------|-----------------------------------|------|--|
| A | AMPERE | IMG | INTERMEDIATE METALLIC CONDUIT |
| AFF | ABOVE FINISHED FLOOR | KVA | KILOVOLT AMPERES |
| AFG | ABOVE FINISHED GRADE | KW | KILOWATT |
| AF | ARC FAULT CIRCUIT INTERRUPTER | MAX | MAXIMUM |
| BKR | BREAKER | MC | MECHANICAL CONDUIT |
| BC | BRANCH CIRCUIT | MFC | MECHANICAL FIBER CONDUIT |
| CATV | CABLE TELEVISION | MIN | MINIMUM |
| CKT | CIRCUIT | MFR | MANUFACTURER |
| EMT | ELECTRICAL CONTRACTOR | NMC | NONMETALLIC-SHEATHED CABLE |
| EF | EXHAUST FAN | Y | YIELD |
| FCU | ELECTRICAL METALLIC TUBING | NEC | 2020 NATIONAL ELECTRICAL CODE, (NFPA 70) |
| FCU | FAN COIL UNIT | SWBD | SWITCHBOARD |
| GC | GENERAL CONTRACTOR | TYP | TYPICAL |
| GF | GROUND FAULT CIRCUIT INTERRUPTER | UNO | UNLESS NOTED OTHERWISE |
| GRS | GALVANIZED RIGID STEEL CONDUIT | WTR | WATER COOLER |
| HID | HIGH INTENSITY DISCHARGE | XFRM | TRANSFORMER |
| IG | DEVICE SHALL HAVE ISOLATED GROUND | | |

The Palmetto Utility Protection Service, Inc.
810 Dutch Square Blvd, Suite 320 Columbia, South Carolina 29210 (803) 939-1117

South Carolina 811
Call 811 Before you Dig

3 DAYS BEFORE DIGGING IN SOUTH CAROLINA

CALL 811

CONTRACTOR SHALL CONTACT THE UNDERGROUND LOCATORS EVERY 10 DAYS FOR AN UPDATE TO UTILITY LOCATIONS.

eti
ENGINEERING, LLC

5725 Bush River Road
Columbia, SC 29212
803.233.9396 (Phone)
803.233.4371 (Fax)

Project Manager:
Troy Lowder PE, x105

ETI #2507-40501

Professional Engineer Seal for Troy R. Lowder, No. 21955, State of South Carolina.

Professional Engineer Seal for E. J. Lowder, No. 022936, State of South Carolina.

08/01/25

HARBISON WEST ELEMENTARY SCHOOL
MARQUEE SIGN ELECTRICAL SERVICE
257 CROSSBOW DR., COLUMBIA, SC 29212

ELEC. SCHEDS., DETAILS, & SPECS.

DRAWN BY: TRL
CHECKED BY: BDT
REVISIONS:

E-1

DATE: 08/01/2025



MARQUEE SIGN ELECTRICAL SERVICE LOCATION. SEE POWER RISER DIAGRAM AND EQUIPMENT RACK SCHEMATIC. COORDINATE EXACT LOCATION WITH OWNER.

APPROXIMATE LOCATION OF NEW UNDERGROUND ELECTRICAL SERVICE. SEE POWER RISER DIAGRAM.

EXISTING UTILITY PAD MOUNT TRANSFORMER. SEE POWER RISER DIAGRAM

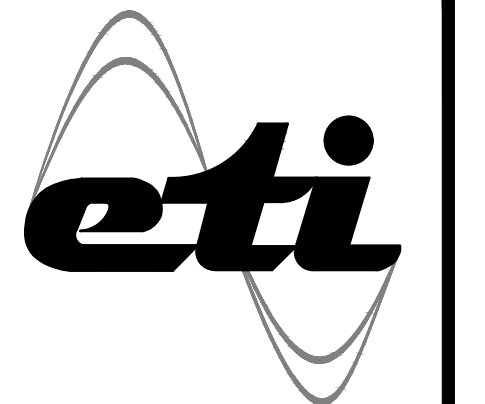

ENGINEERING, LLC

5725 Bush River Road
Columbia, SC 29212
803.233.9396 (Phone)
803.233.4371 (Fax)

Project Manager:
Troy Lowder PE, x105

ETI #2507-40501

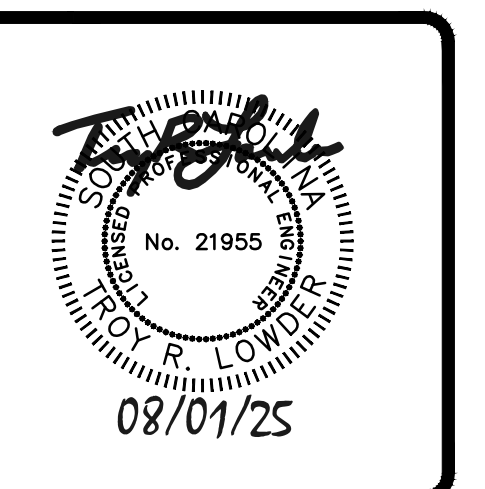
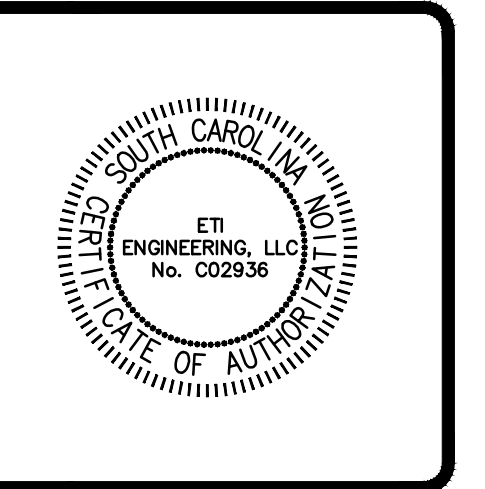

HARBISON WEST ELEMENTARY SCHOOL
MARQUEE SIGN ELECTRICAL SERVICE
257 CROSSBOW DR., COLUMBIA, SC 29212
ELECTRICAL SITE PLAN

DRAWN BY: TRL
CHECKED BY: BDT
REVISIONS:

E-2
DATE: 08/01/2025