

Request for Proposals – September 2, 2025

Project: Gallia Storage Shed Project
160 Centenary Church Road (near bus garage)
Gallipolis, OH 45631

Owner/ District: Gallipolis City School District Board of Education
61 State Street
Gallipolis, Ohio 45631

Response Deadline: September 22, 2025 at 1:00 p.m. local time

The District seeks competitive Proposals for the above-identified Project, subject to the terms and conditions of this Request for Proposals (“RFP”) and its attachments.

The District anticipates the cost for the Project will be less than the amount specified in O.R.C. Section 9.17, therefore the competitive bidding requirements contained in O.R.C. Section 3313.46 do not apply to the procurement of the contractor for the Project. Any references in the RFP to “bid” and “bidding” are to be read consistent with the competitive proposal process being implemented.

Article 1 — General Information

1.1 Project Description

1.1.1 Project Scope. The Project consists of all labor, materials, equipment, and any other services necessary to complete the construction of a new storage shed building as outlined in the drawings prepared by VSWC Architects and attached to this RFP as **Attachment 1**.

1.1.2 Anticipated Project Schedule. Preliminary services, if any, will begin upon execution of the Agreement. It is anticipated that the Date of Substantial Completion will be **February 15, 2026**.

1.1.3 Design Professional. The Design Professional for this Project is VSWC Architects. The Design Professional prepared the drawings for the Work. The Design Professional will also provide construction administration services for the Project. The Contractor will coordinate with the Design Professional, as instructed by the Owner.

Article 2 — Proposal Submission and Selection Process

2.1 Preparation of Proposals

2.1.1 The Proposal will include an executive summary, a completed Proposal Form (in the form furnished with this RFP), and additional materials prepared by the Proposer containing information related to the Evaluation Criteria set forth in Section 2.3.3 of this RFP (limited to 20 pages).

2.1.2 Proposals must follow the following format guidelines:

- .1 Proposals shall be formatted for letter-size (8.5” x 11”) paper, with exception to any draft plan drawings which may be submitted in a larger size format.
- .2 Page numbers must be included at the bottom of each page.
- .3 Minimum 12-point font.

2.1.3 Proposer shall base its pricing on the scope of Work provided in the RFP and **Attachment 1**.

2.1.4 Complete all blank spaces on the Proposal Form in ink or typewritten, in words and figures, and in figures only where no space is provided for words, and sign the form. In the case of a discrepancy between the numbers and words written, the District reserves the right to consult with the Proposer and determine the correct amount.

2.1.5 Submit the completed Proposal to the District prior to the Response Deadline.

2.1.5.1 The electronic copy of the Proposal can be submitted as one PDF file, with the PDF named with the Proposer's name and title of the Project, via email to: **Craig Wright, Superintendent, at craig.wright@gc-k12.org with a courtesy copy to Clayton Arvin, VSWC Architects at Clayton.arvin@vswc.com.**

2.1.5.2 The Proposal can be enclosed in a sealed opaque envelope with the Proposer's name and title of the Project printed in the upper left-hand corner and addressed to:

**Gallipolis City School District Board of Education
ATTN: Craig Wright, Superintendent
61 State Street
Gallipolis, Ohio 45631**

2.1.5.3 Pre-Proposal Meeting. A pre-proposal meeting will be held at 160 Centenary Church Road, Gallipolis, OH 45631 on September 15, 2025 at 10:00 a.m. with a site visit to immediately follow. Attendance is highly recommended.

2.2 Opening of Proposals. Proposals will be accepted until the Response Deadline. Each Proposer is responsible for ensuring that its Proposal is received by the District in accordance with this Request for Proposals by the Response Deadline. The District reserves the right to accept a Proposal after the Response Deadline in its sole discretion.

2.3 Evaluation of Proposals.

2.3.1 Standard of Award. The District intends to award the Contract for the Work to the Proposer submitting the Proposal determined to be in the District's best interest (the "Selected Proposer"), with price being considered, but not being the only determining factor. The District reserves the right to negotiate pricing for the Work with the Selected Proposer.

2.3.2 Clarification of Proposals. The District reserves the right to discuss the contents of the Proposal with the Proposer and request additional information from the Proposer.

2.3.3 Evaluation Criteria. The District, in its sole discretion, will evaluate the Proposers and Proposals to determine which Proposal is in the District's best interest. In making such determination, the District may consider the following criteria, and any such other criteria as it determines proper:

2.3.3.1 Proposer's work history. 15 Points.

- .1** Proposer should have a record of consistent customer satisfaction and of consistent completion of projects, including projects that are comparable to or larger and more complex than District's Project, on time and in accordance with the respective contract documents. If Proposer's management (i.e., president, chairman of the board, or any director) operates or has operated another construction company, District may consider the work history of that company in determining Proposer's qualifications and experience.
- .2** District may consider Proposer's prior experience on other projects for District, including Proposer's demonstrated ability to complete its work on these projects in accordance with the Contract Documents and on time and its ability to work with District.
- .3** Proposer authorizes District and its representatives to contact the owners and design professionals on projects on which Proposer has worked, and authorizes and requests such owners and design professionals to provide District with a candid evaluation of Proposer's performance. By submitting its Proposal, Proposer agrees that if it or any person at its urging, directly or indirectly, brings an action against any of such owners or design professionals or their employees as a result of or related to such evaluation and such action is not successful, Proposer will reimburse such owners, design professionals and/or their employees for all legal fees and expenses incurred by them that are related to

such legal action, including the cost of collection. This obligation is expressly intended for the benefit of such owners, design professionals, and their employees.

2.3.3.2 Proposer's Resources. 15 points. Proposers should have the financial ability to complete the Project successfully and on time and the experience, adequacy, and numbers of Proposer's work force/project team.

- .1 The qualifications of individuals in the Proposers' organization will be considered. Therefore, Proposers should provide detailed information (name, title, and experience) for the individuals that will be assigned to service the District.
- .2 Project Team - Identify the Project Team, including sub-contractors, the percentage of work to be performed by each firm along with the address of each sub-contractor's office. Replicate a completed version of the table below in your proposal.

Firm Name	Location	Date of Establishment	Role	Percentage of Contract

2.3.3.3 Compliance with Federal, State, and Local Laws, Rules, and Regulations. 10 points. Proposers should have a record of consistent compliance with federal, state, and local laws, rules, and regulations, including but not limited to the Occupational Safety and Health Act.

2.3.3.4 Proposer's Subcontractors. 5 points. The foregoing information with respect to any of the subcontractors that Proposer intends to use on the Project

2.3.3.5 Participation in a Drug-Free Workplace Program. 5 points. Proposer's participation in a drug-free workplace program through the Ohio Bureau of Workers Compensation or a program approved by the Bureau of Workers Compensation.

2.3.3.6 Project Approach/Technical Understanding. 20 points. Proposers should provide a conceptual plan for the project, tentative project schedule, any proposed alternates to the base scope of Work, and any proposed alternative plans.

2.3.3.7 Cost. 20 points. The maximum score for cost will be assigned to the Proposer offering the lowest price. The second lowest price will receive the second highest score in this category, and so on.

2.3.3.8 Other Essential Factors. 10 points. The District may award the maximum points to one Proposer for other essential factors, including proposed alternate Project schedule, as determined by the District in its sole discretion. The District has the option to also award zero to nine points to the remaining Proposers' scores without limitation.

2.3.4 Upon request of the District, the Proposer will complete and submit to District, within five (5) days of the request, the following documents:

2.3.4.1 The list of all proposed subcontractors, suppliers, and manufacturers.

2.3.4.2 A proposed schedule for the Work.

2.3.4.3 A proposed schedule of values, allocating the breakdown of labor and material for the Project, including the sum for each, on AIA Documents G702 and G703, or another form acceptable to the District.

2.3.5 After approval by District of the list of proposed subcontractors, suppliers, and manufacturers submitted by the successful Proposer, the list may not be changed unless written approval of the change is authorized by District. Failure to timely submit requested information may result in the determination that Proposer's Proposal is not in the best interest of the District.

2.3.6 By submitting its Proposal, the Proposer agrees that District's determination of which Proposal is in the best interest of the District will be final and conclusive, and that if the Proposer, or any person at Proposer's urging, directly or indirectly challenges such determination in any legal proceeding and such challenge is not successful, Proposer will reimburse District for all legal fees and expenses incurred by District that are related to such challenge, including the cost of collection.

2.4 Negotiation of Agreement.

2.4.1 The District will negotiate an agreement with the Selected Proposer that will be entered into by the Selected Proposer and the District for the Project.

2.4.2 The form of agreement is attached to this RFP at **Attachment 3**. If Proposers would like to propose any deviations from the terms of the agreement, Proposers must identify those terms and submit your proposed modified language in detail in your Proposal in a section clearly titled "Proposed Modifications to Agreement Terms." Failure to do so shall be deemed a waiver of the right to negotiate the terms. Modifications may be accepted in the Owner's sole discretion and may be taken into account by Owner when determining the Proposal in the best interest of the Owner.

2.4.3 If for any reason the District and Selected Proposer are unable to finalize terms of an agreement for the Project, the District may suspend negotiations with the Selected Proposer and initiate negotiations with the next Proposer determined to be in the District's best interest, and so on, until the agreement is fully executed for the Project, or the District rejects all Proposals.

Article 3 — Additional Instructions

3.1 Questions

3.1.1 All questions must be submitted in writing to: **Clayton Arvin, at clayton.arvin@vswc.com**, by 5:00 p.m. five (5) days prior to the submission deadline provided above. The questions and answers will be emailed to all individuals and firms that were provided with a copy of the Request for Proposals.

3.1.2 The District and Design Professional, if any, may also email other Project-related information to the individuals and firms that were provided with a copy of the Request for Proposals.

3.1.3 Addenda.

3.1.3.1 Should any question prompt the District to amend the Request for Proposal, a notice will be sent to all individuals and firms that were provided with a copy of the Request for Proposals. Addenda will be deemed to have been validly given if emailed or otherwise furnished to each Proposer's contact person of record.

3.1.3.2 When an Addendum to this Request for Proposal is necessary less than three days before the Proposal deadline, the District may extend the Proposal deadline through an announcement via email. The District will make reasonable attempts to contact all necessary individuals.

3.2 Proposal Certifications

3.2.1 By submitting a Proposal, the Proposer certifies to the District that:

3.2.1.1 the Proposer has carefully reviewed the Project site and RFP and its Attachments to become familiar with the requirements for the Work and has, to the extent applicable, included all costs necessary to provide labor and materials for the Work in its Proposal, including incidentals, whether or not specifically called for in the RFP and its Attachments and to become familiar with the limitations and conditions related to the Work covered by the Proposal and has included in the Proposal a sum to cover the cost of such items;

3.2.1.2 the Proposer is not the subject of an unresolved finding for recovery issued by the Auditor of State under ORC Section 9.24;

3.2.1.3 the Proposer is not debarred under ORC Section 153.02;

3.2.1.4 the Proposer has not been found by a court to be in default of a judgment or breach of settlement agreement; and

3.2.1.5 the Proposer has not violated ORC Section 3517.102 by exceeding allowable campaign contributions.

3.3 Cancellation and Rejection; Waiver of Minor Irregularities

3.3.1 The District may reject all Proposals and cancel all or any portion of this solicitation at any time for any reason. The District will have no liability to any Proposer arising out of any cancellation of this solicitation or rejection of any related submission.

3.3.2 The District shall reject a Proposal if the District determines that:

3.3.2.1 the Contract could not be awarded under ORC Section 9.24 if a political subdivision were holding the Contract because the recommended Proposer has a finding for recovery issued by the Auditor of State, and the finding for recovery is unresolved;

3.3.2.2 the recommended Proposer is debarred under ORC Section 153.02;

3.3.2.3 the recommended Proposer has violated ORC Section 3517.102 by exceeding allowable campaign contributions; or

3.3.2.4 the District has determined that the Proposer intended to engage in collusion with intent to defraud or other illegal practices.

3.3.3 The District may waive minor irregularities in its sole discretion.

3.4 Proposal Revision. The District may request that a Proposer submit a revised Proposal to clarify any questions which may arise while evaluating the Proposals. If the District requests a clarification of any Proposal, the Proposer must submit the clarification in writing to the District within 3 business days.

3.5 Proposal Withdrawal. If the Selected Proposer withdraws its proposal after selection, the District may award the Contract to the firm next determined to be in the District's best interest.

3.6 Applicable Law and Forum. The rights of any Proposer or any party to a subsequent agreement shall be governed by Ohio law, and only the Court of Common Pleas of the County in which the Project is located shall have jurisdiction over any action or proceeding related to the Proposal or any subsequent agreement. The Proposer irrevocably consents to that jurisdiction.

3.7 Public Records. Pursuant to ORC Section 9.28, documents submitted to the District in response to this Request for Proposal will not be available for public inspection under ORC Section 149.43 until after the District either enters into a contract for the Work or the District cancels this Request for Proposals.

3.8 Expenses of the Proposers. The District accepts no liability for the costs and expenses incurred by the Proposers in responding to this Request for Proposals, responding to clarification requests and discussion meetings, preparing resubmittals, potential interviews, subsequent negotiations, and any other activities included as part of this procurement process. Each Proposer shall prepare the required materials and submittals and attend meetings and interviews at its own expense.

3.9 Pre-Proposal Site Visit. District may provide Proposers access to the Project sites to conduct examinations, investigations, explorations, tests, and studies as Proposer deems necessary for submission of a Proposal. Proposer shall fill all holes and clean up and restore the Project sites to their former condition upon completion of such explorations, investigations, tests, and studies. Proposer shall comply with all applicable Laws and Regulations and District's policies relative to excavation and utility locates. Other than the Pre-Proposal Meeting, Proposers may visit the sites by contacting Craig Wright, Superintendent at craig.wright@gc-k12.org to set an appointment.

Article 4 — Attachments

4.1 Attachment 1. Drawings

4.2 Attachment 2. Proposal Form

4.3 Attachment 3. Form of Agreement with Exhibits

[End of Request for Proposals]

Attachment 1

DRAWINGS

Gallia Storage Shed

for

Gallipolis City Schools

Construction Documents

Owner
 Gallipolis City Schools
 61 State St
 Gallipolis, OH 45631
 (740) 446-3211

Architect
 VSWC Architects
 414 Reading Road, Mason, OH 45040
 PH: (513) 398-4931
 Contact: Chris Dumford (chris@vswc.com)



Set Issuance

8/19/25 Construction Documents

Revision

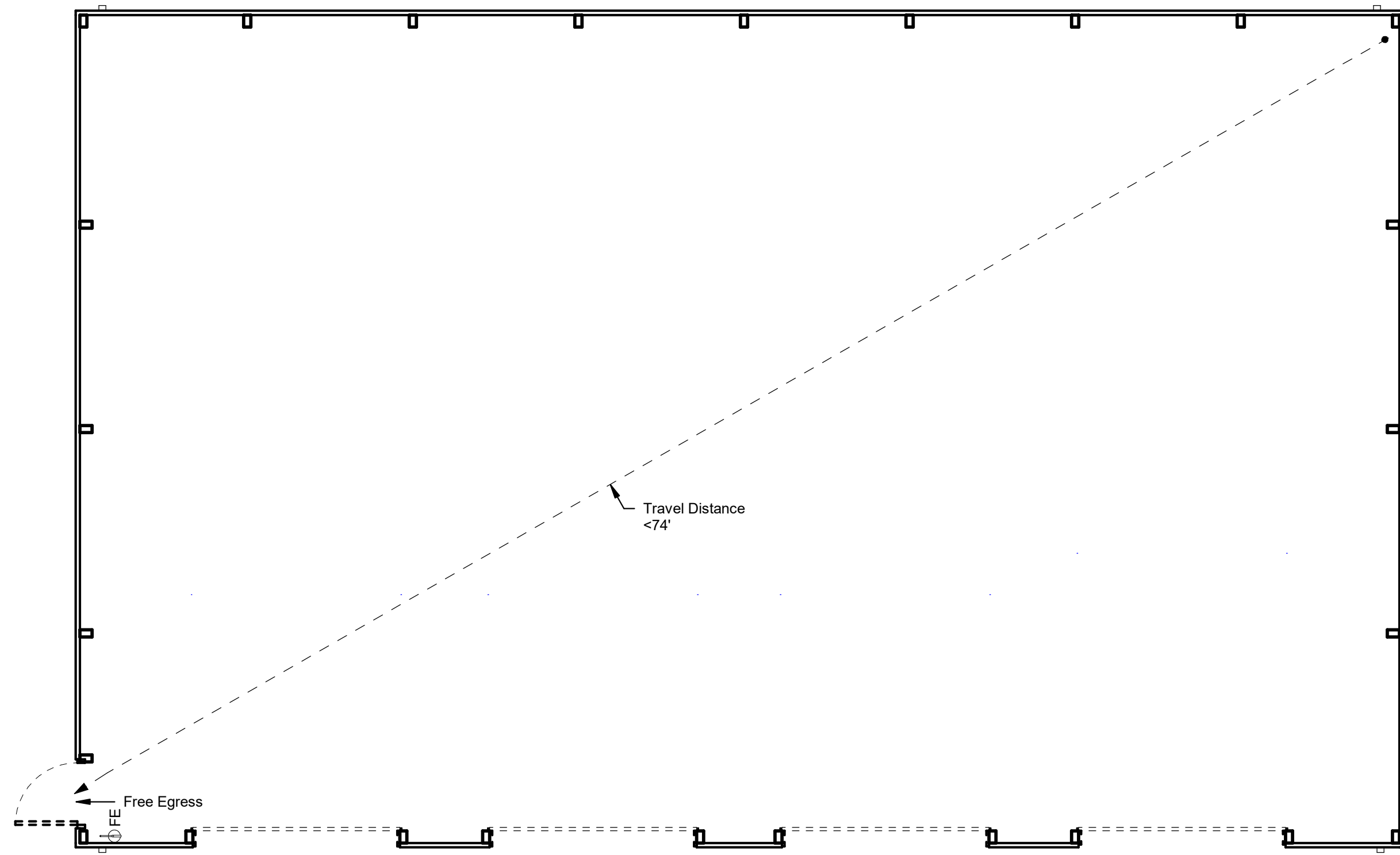

1 Code Plan - First Floor
 G001 3/16" = 1'-0"

Code Analysis Table			
Proposed Condition	Code Reference	Calculation/Data	Comment
Project Name: Gallia Storage Shed			
Scope of Project: New 2,600 SF Storage Shed Building			
Project Description: Project is an Storage Shed (unoccupied Utility Building), constructed using wood "pole barn" construction. Building is unconditioned. Ventilation is provided via openings for future operable doors (man-door and overhead sectional doors). There is no plumbing or electric work associated with this building. Wood roof trusses are pre-engineered (final design of truss members to be provided by contractor, bearing the seal of an Ohio-licensed Engineer). All other components are designed by the design Professional of Record.			
Applicable Code	OBC 2024		
Type of Construction	UB	OBC Table 601	
Main Occupancy Classification	U	OBC 302.312	Shed (not used for agricultural purposes)
Mixed Use	N/A	OBC 508	
Accessory Occupancies	N/A	OBC 508.2	
Mixed Use Nonseparated	N/A	OBC 508.3	
Mixed Use Separated	N/A	OBC 508.4, 507.8	
Incidental Occupancies	N/A	OBC Table 509	
Fire Suppression (general)	Not Sprinkled	OBC 603	
Fire Suppression (basement)	N/A	OBC 603	
Fire Alarm	No Fire Alarm Provided	OBC 907	
Fire Extinguishers	Provided	OBC 906	Within 75' of occupied spaces
Height Allowable (Feet)	40'	OBC Table 504.3	
Height Actual (Feet)	<24'	-OK	
Height Allowable (Stories)	1	OBC Table 504.4	
Height Actual (Stories)	1	-OK	
Area Allowable (per story)			
Tabular Area	9,000	OBC Table 506.2	
Frontage Increase	N/A	OBC 506.3.3	
Total Allowable Area	9,000		
Area Actual (largest story)	2,600	-OK	
Exit Access Travel Allow	200'	OBC Table 1017.2	
Exit Access Travel Actual	<74'	-OK	
Common Path of Travel Allow	100'	OBC Table 1008.2.1	
Common Path of Travel Actual	<74'	-OK	
Exit Separation Req'd	1/2 Area Diagonal (min.)	OBC 1007.1.1	
Exit Separation Actual	>1/2 Diagonal	-OK	
Number of Exits Req'd	1	OBC Table 1008.3.4(2)	<29 Occupants (0)
Number of Exits Actual	1	-OK	
Corridor Width Req'd	36" (where serving <50)	OBC Table 1020.2	
Corridor Width Actual	44" (where serving 51 to 99)	OBC Table 1020.2	
Dead End Corridors	72" (where serving >99)	OBC Table 1020.2	
Corridor Width Actual	N/A	-OK	No Occupiable Space/No Corridors
Dead End Corridors	Not restricted	OBC 1020.4	
Corridors w/DL<50	50'	OBC 1020.4, Exception 2	
Corridors w/DL=49	N/A	OBC 1020.4, Exception 2	No Occupiable Space/No Corridors
Dead end Corridor Actual Max.	N/A	-OK	
Accessibility	Accessible Route Not Req'd	1103.2.4	U Occupancy
Occupant Load	0	OBC 202	Definition of Occupiable Space
Fire Rating Building Elements	0 hr.	OBC Table 601	
Fire Rating of Exterior Walls	0 hr.	OBC 705.8 & Table 602	No other building within 30'
Based on Separation Dist.	0 hr.	OBC 705.8 & Table 602	No property line within 30'
Based on Dist. From Prop. Line	0 hr.	OBC 705.8 & Table 602	

Drawing Index

- G001 Title Sheet
- A111 Plans, Elevations, Sections
- S111 Foundation Plan, Details and Sections
- S331 Framing Plan and Details

Gallia Storage Shed
 185 Centenary Church Road, Gallipolis, OH 45631

for
 Gallipolis City Schools
 61 State St, Gallipolis, OH 45631



2 Site Plan
 G001 1" = 60'-0"

Site Plan Numbered Notes

- 1 In the area of the new building, the site contains existing concrete slab and foundations (from a building previously demolished), manufactured storage sheds (mobile), and piles of loose fill. Prior to start of construction, the Owner shall relocate the mobile storage sheds, demolish the existing slab and foundations (as required for the new work), and level the existing grade.
- 2 Exist. chain link fencing to remain. Protect during construction.
- 3 Exist. gate. Locate building with sidewall length centered on gate opening.
- 4 Exist. overhead electric service running through site, to remain unmodified.

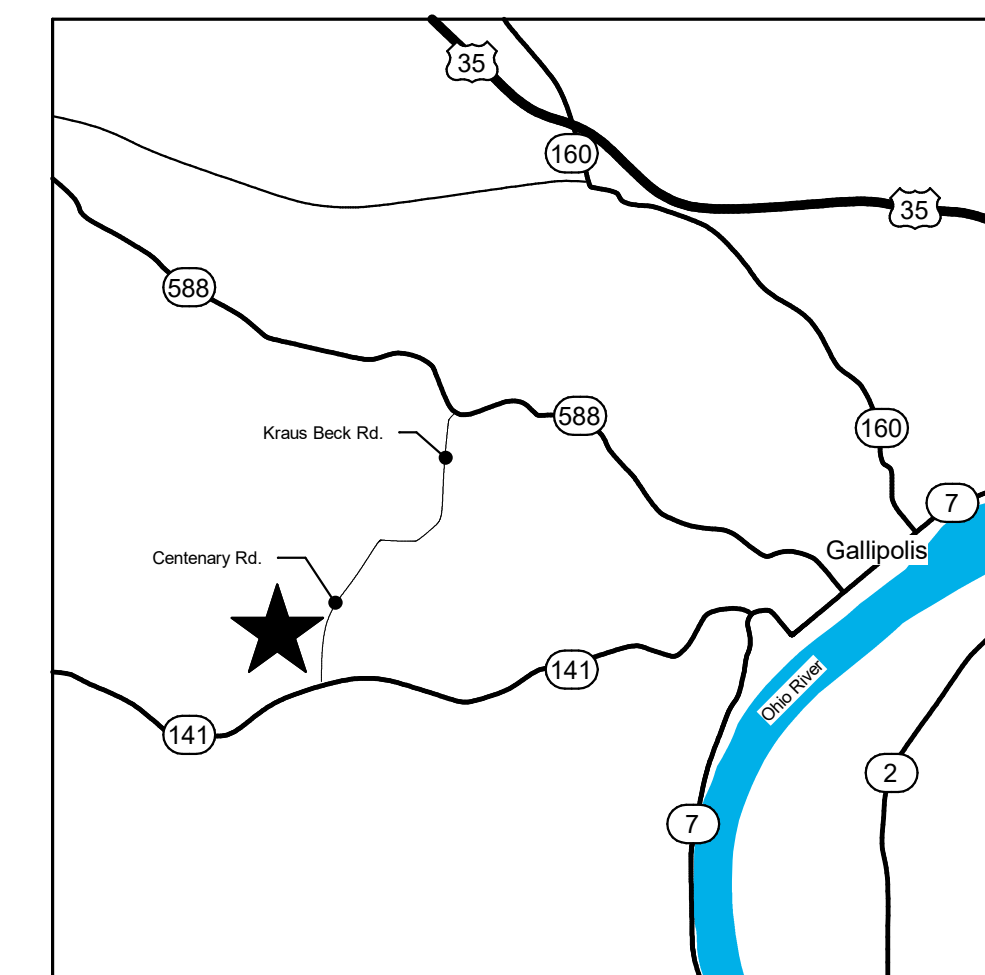

Regional Vicinity Map
 NTS

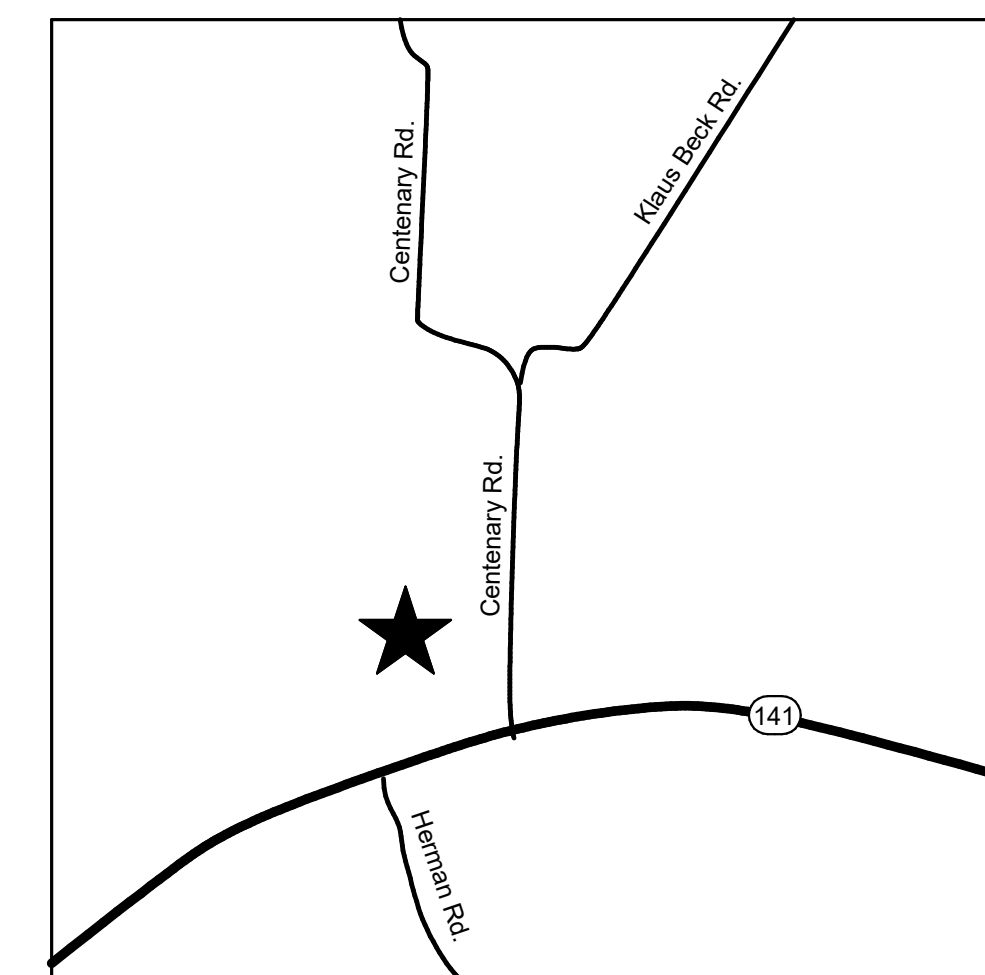

Vicinity Map
 NTS

Construction Documents

Not Published
 All Rights Reserved
 This document is the product and exclusive property of the Architect. This document and the information it contains may not be copied or used for other than the specific purpose for which it was prepared without written consent of VSWC Architects.
 Christopher S. Dumford
 License #11547 Exp. Date 12/31/25
 COPYRIGHT © 2025



VSWC Project Number:404-XX

Title Sheet

G001

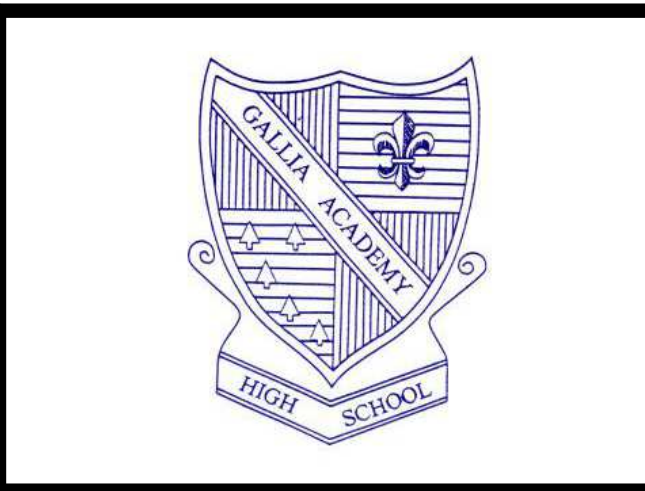

Set Issuance
8/19/25 Construction Documents

Revision

Gallia Storage Shed
185 Centenary Church Road, Gallipolis, OH 45631
for
Gallipolis City Schools
61 State St, Gallipolis, OH 45631

Construction Documents

Not Published
All Rights Reserved
This document is the product and exclusive property of the Architect. This document and the information it contains may not be copied or used for other than the specific purpose for which it was prepared without written consent of VSWC Architects.
Christopher S. Dumford
License #11547 Exp. Date 12/31/25
COPYRIGHT © 2025

VSWC ARCHITECTS
414 Reading Road, Mason, OH 45040

VSWC Project Number:404-XX

Plans, Elevations, Sections
A111

Athletic Storage Shed General Notes

- A. Finish colors of all metal panels and trim to match nearby Bus Garage building.

Storage Shed Numbered Notes

- 1 Wall assembly; 24 ga. x 1 1/4" corrugated metal wall panel over flat 2x4 wood wall girts over PT laminated wood posts. See Struct. Dwg. for post sizes and attachments.
- 2 4" x 3 1/2" x 24 ga. pre-finished metal downspout to precast concrete splash block.
- 3 5" concrete slab w/ WWF over 4" granular fill, provided by Owner.
- 4 6" compacted gravel base, provided by Owner.
- 5 Owner-provided wall-mounted Fire Extinguisher (mounted at 48" to top) with "Fire Extinguisher" signage above.
- 6 Existing chain link fence to remain.
- 7 Roof assembly; exposed fastener 24 ga. x 1 1/4" corrugated metal roof panel over flat 2x4 wood wall girts over pre-engineered wood trusses. See Struct. Dwg. for member sizing and attachment.
- 8 24 ga. pre-finished metal sculpted gutter. See 9/A111.
- 9 24 ga. pre-finished metal ridge cap.
- 10 24 ga. pre-finished metal rake trim. See 11/A111.
- 11 24 ga. pre-finished metal outside corner trim. See 10/A111.
- 12 Opening trimmed at head and jambs with 24 ga. pre-finished metal for future Owner-provided overhead sectional door (manually operated).
- 13 Opening trimmed at head and jambs with 24 ga. pre-finished metal for future Owner-provided man-door (which will be constant egress).
- 14 Concrete post footing. See Struct. Dwg.

Door Schedule			
Door Number	Width	Height	Comments
01	3' - 0"	7' - 0"	Swinging man door. Future, by Owner.
02	10' - 0"	12' - 0"	Overhead sectional door. Future, by Owner.
03	10' - 0"	12' - 0"	Overhead sectional door. Future, by Owner.
04	10' - 0"	12' - 0"	Overhead sectional door. Future, by Owner.
05	10' - 0"	14' - 0"	Overhead sectional door. Future, by Owner.

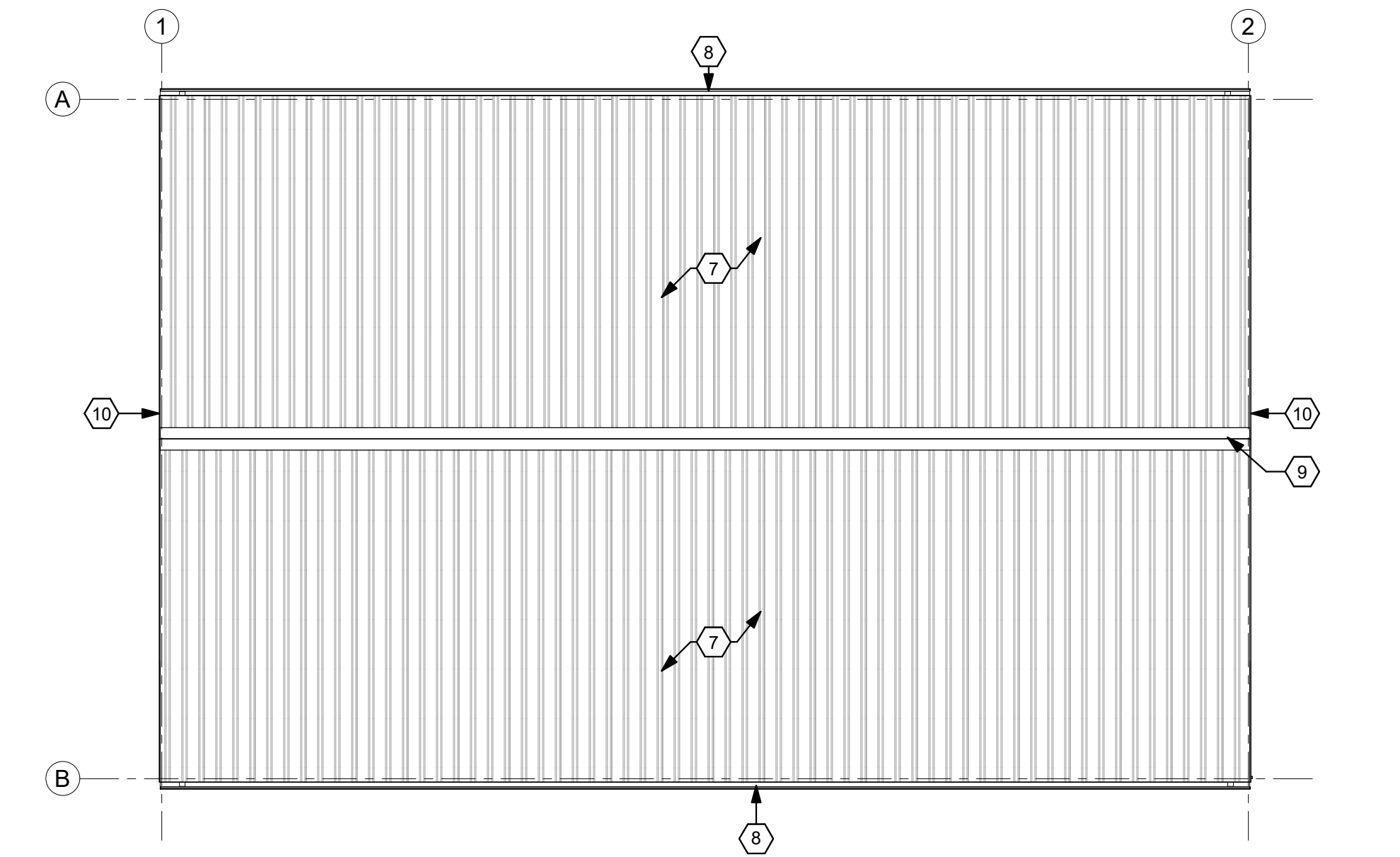

2 Roof Plan
A111
1/8" = 1'-0"

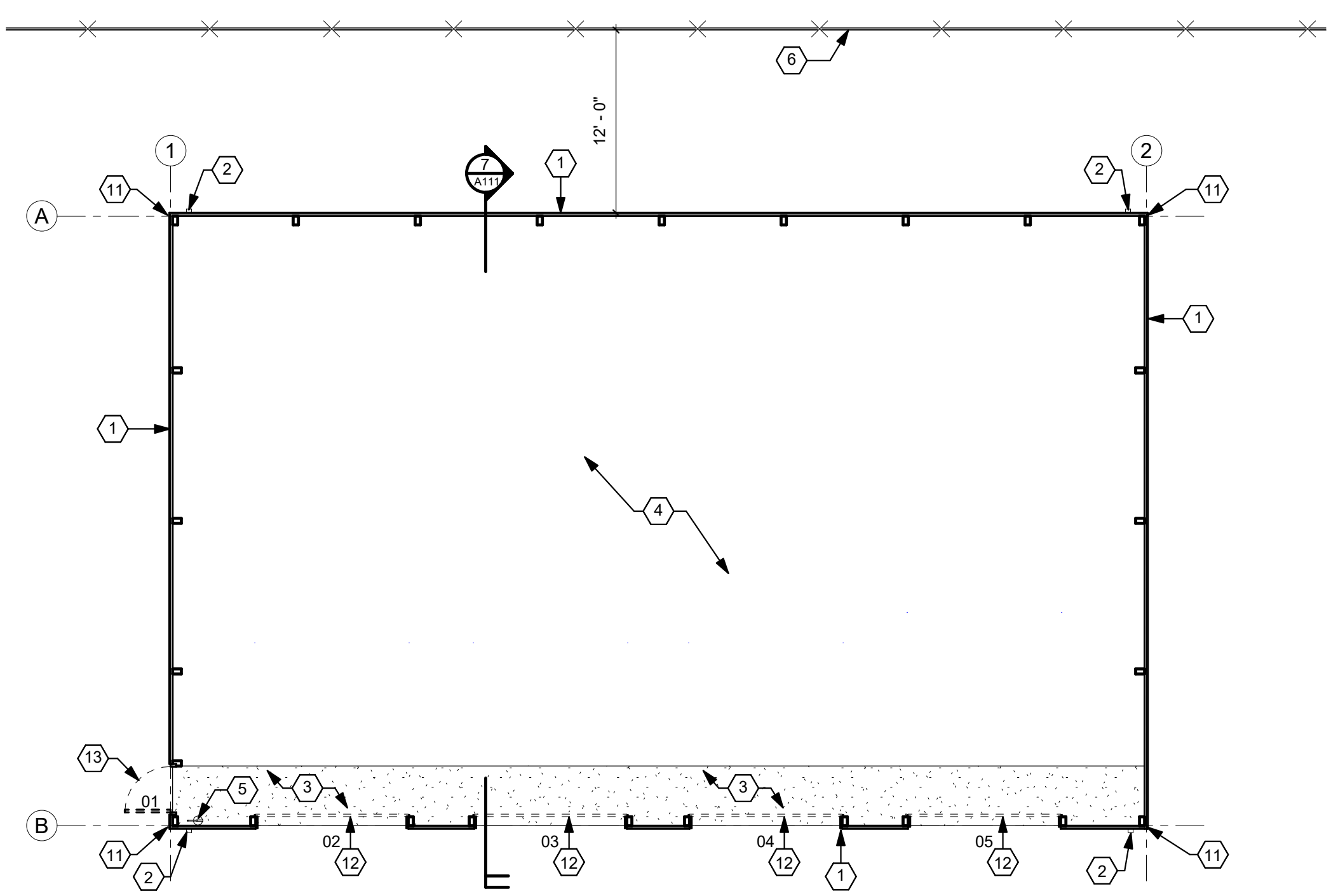

1 Floor Plan
A111
1/8" = 1'-0"

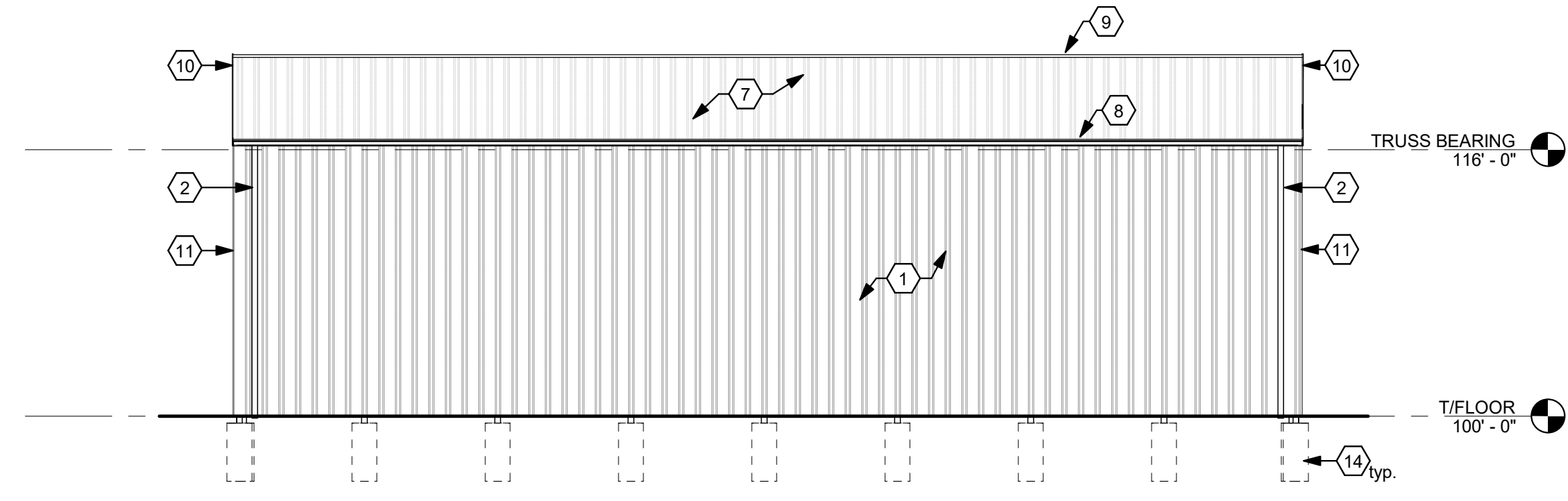

4 West Elevation
A111
1/8" = 1'-0"

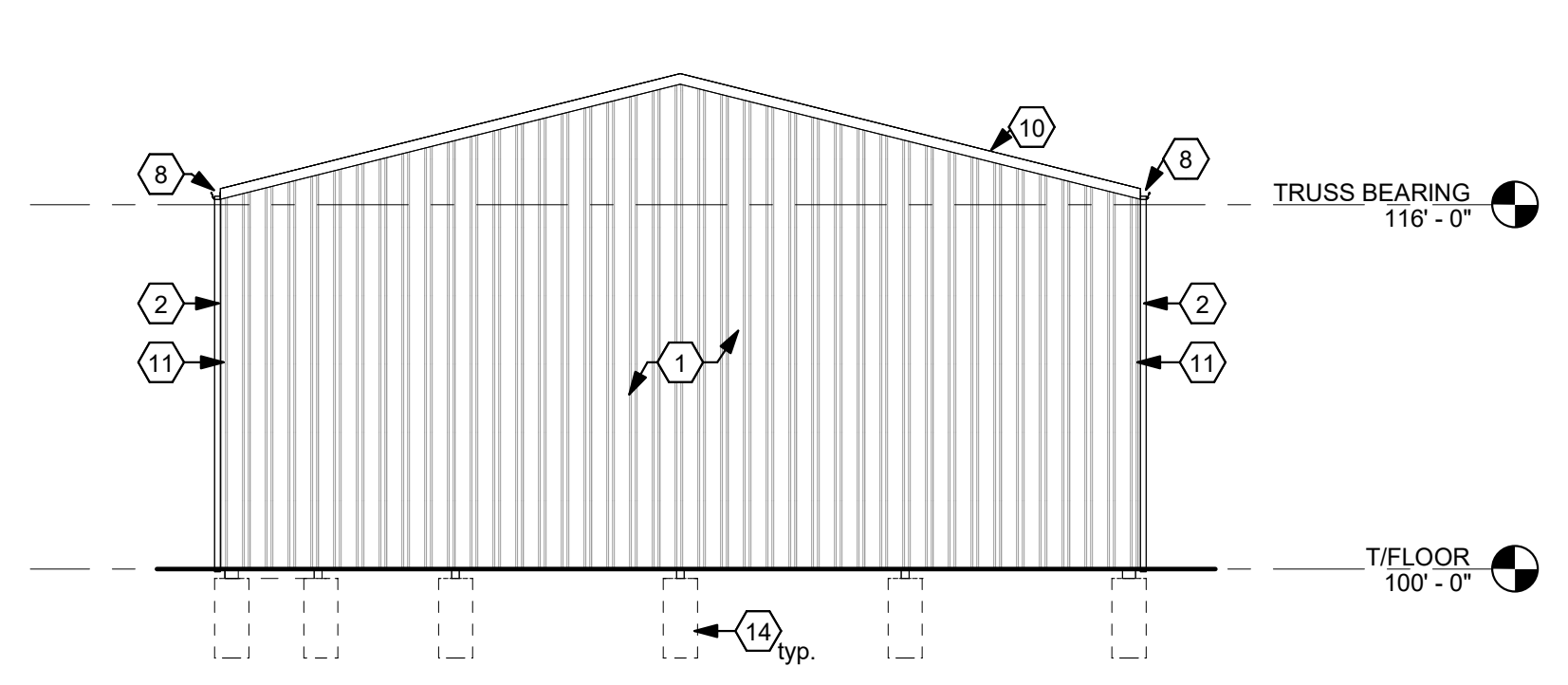

3 North Elevation
A111
1/8" = 1'-0"

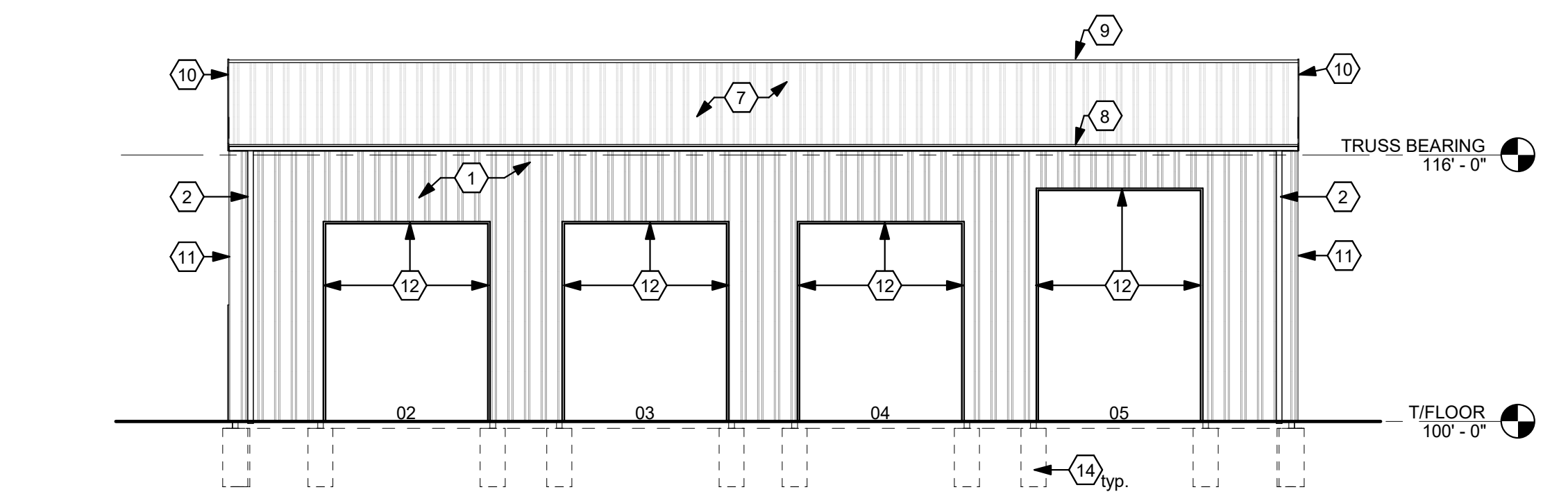

6 East Elevation
A111
1/8" = 1'-0"

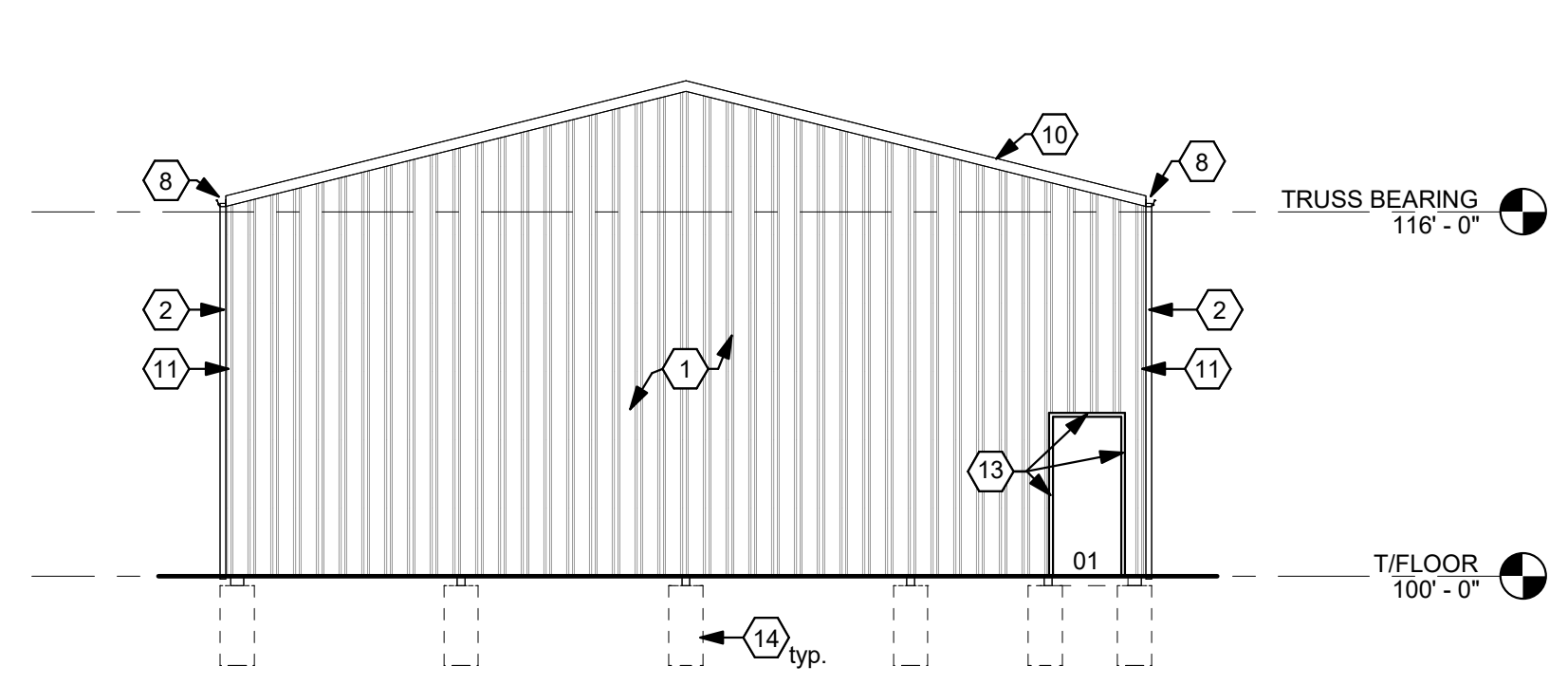

5 South Elevation
A111
1/8" = 1'-0"

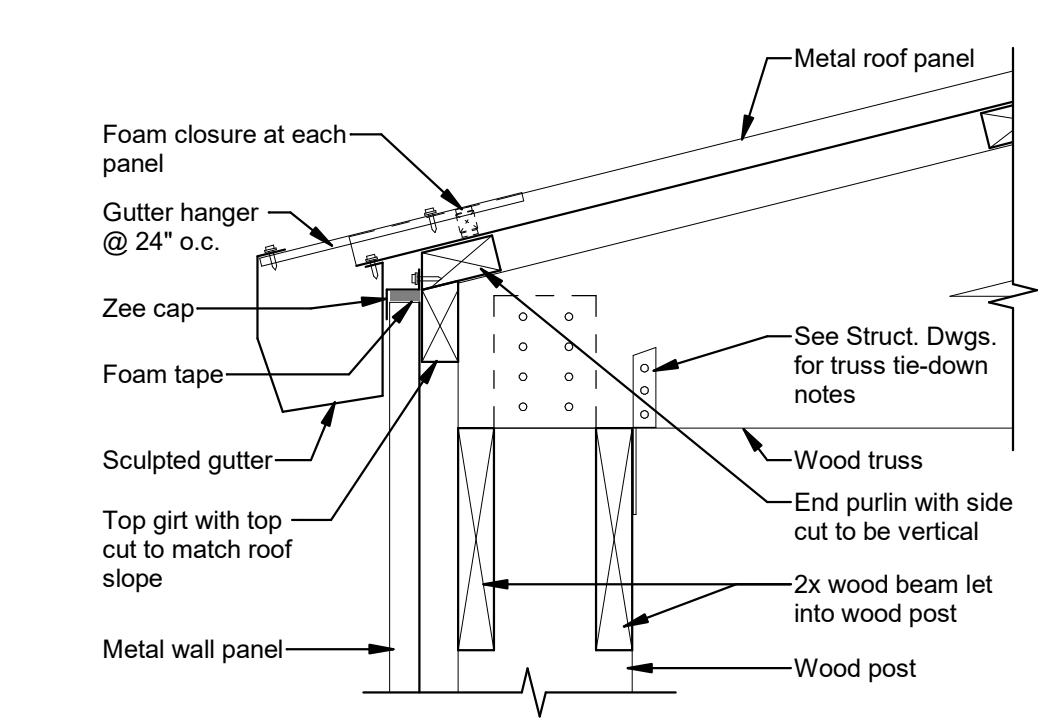

9 Eave Detail
A111
1 1/2" = 1'-0"

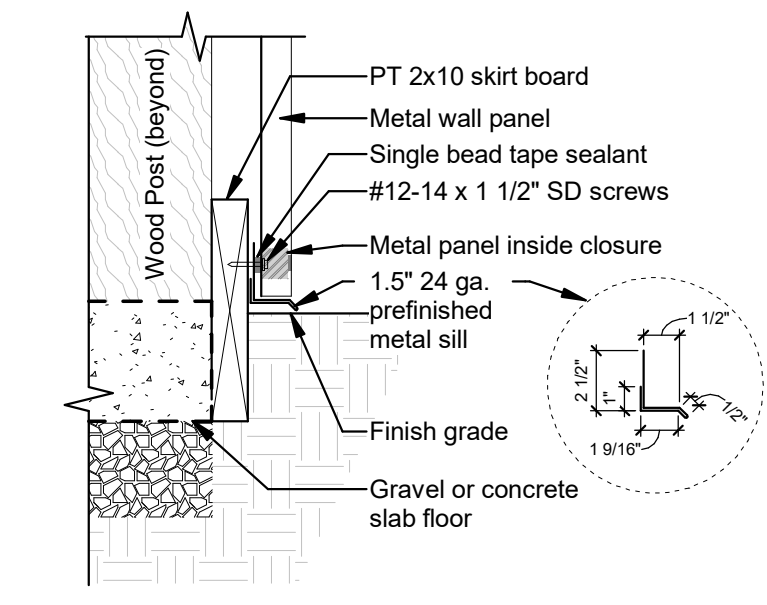

8 Exterior Metal Wall Panel Base Detail
A111
1 1/2" = 1'-0"

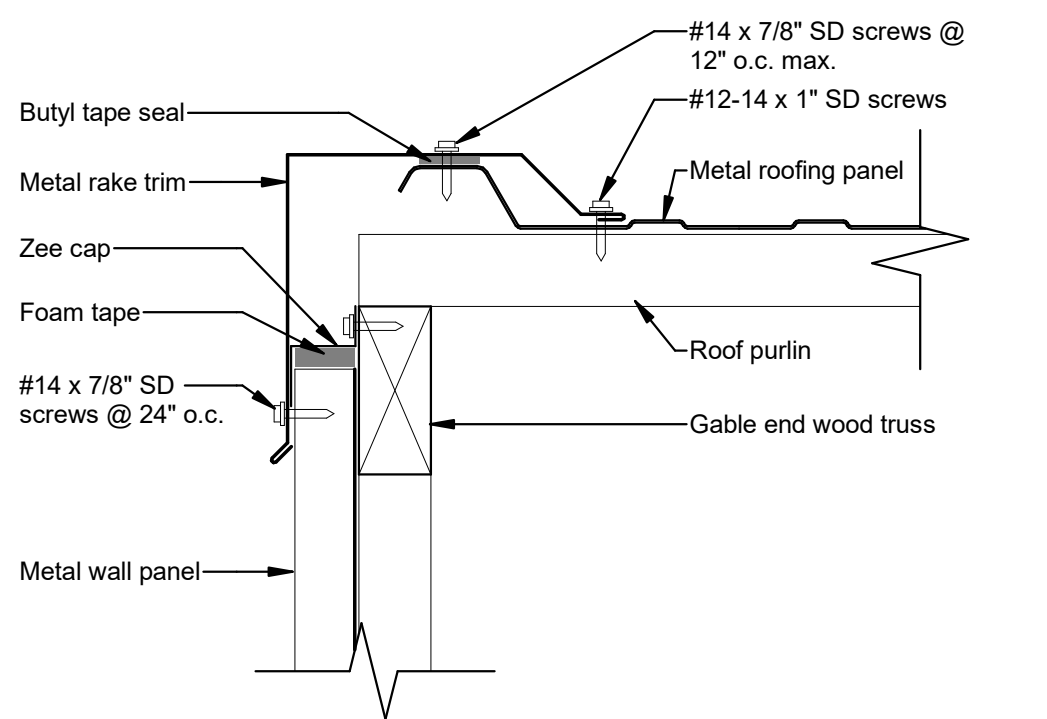

11 Rake Detail
A111
3" = 1'-0"

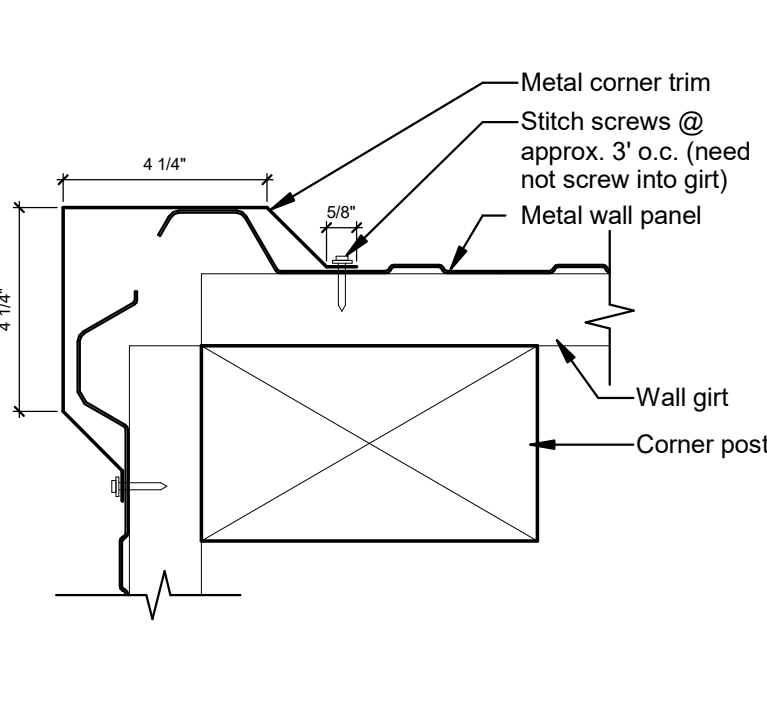

10 Exterior Metal Panel Corner Detail
A111
3" = 1'-0"

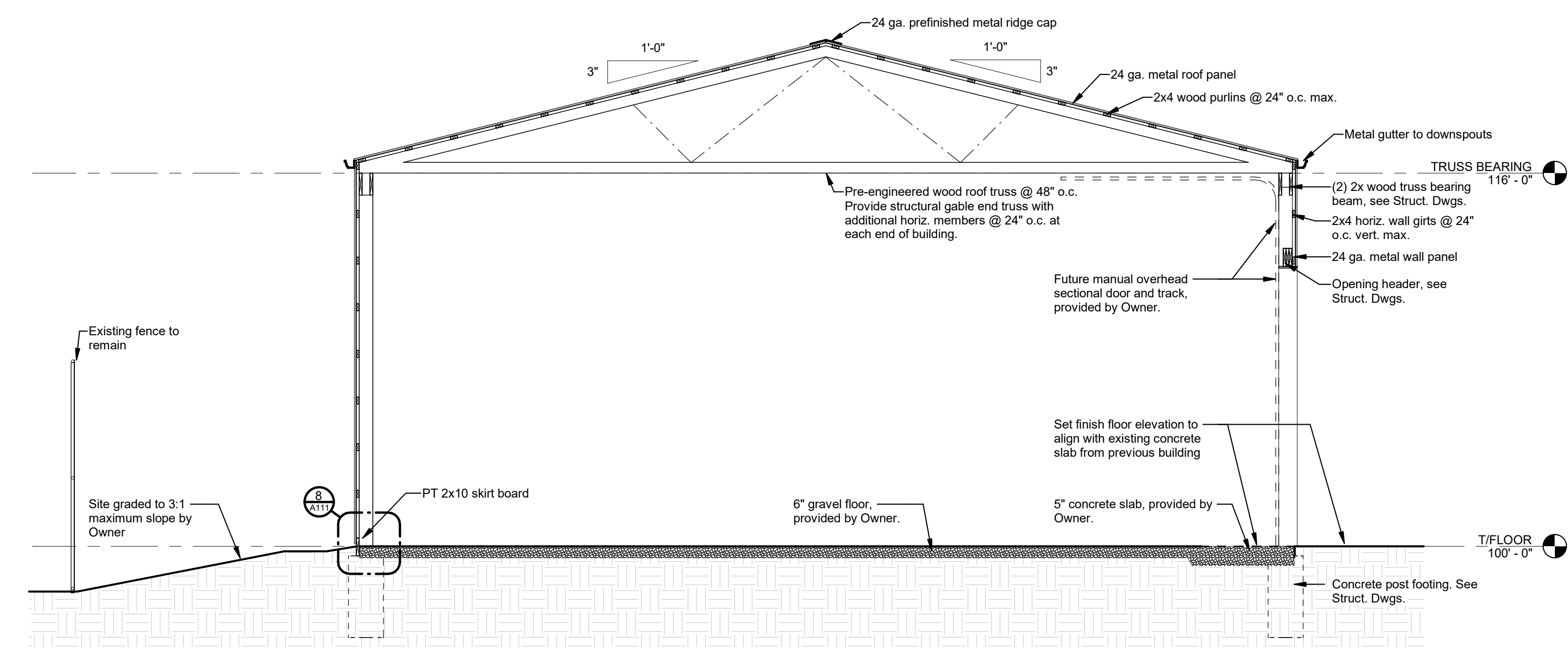

7 Building Section
A111
1/4" = 1'-0"

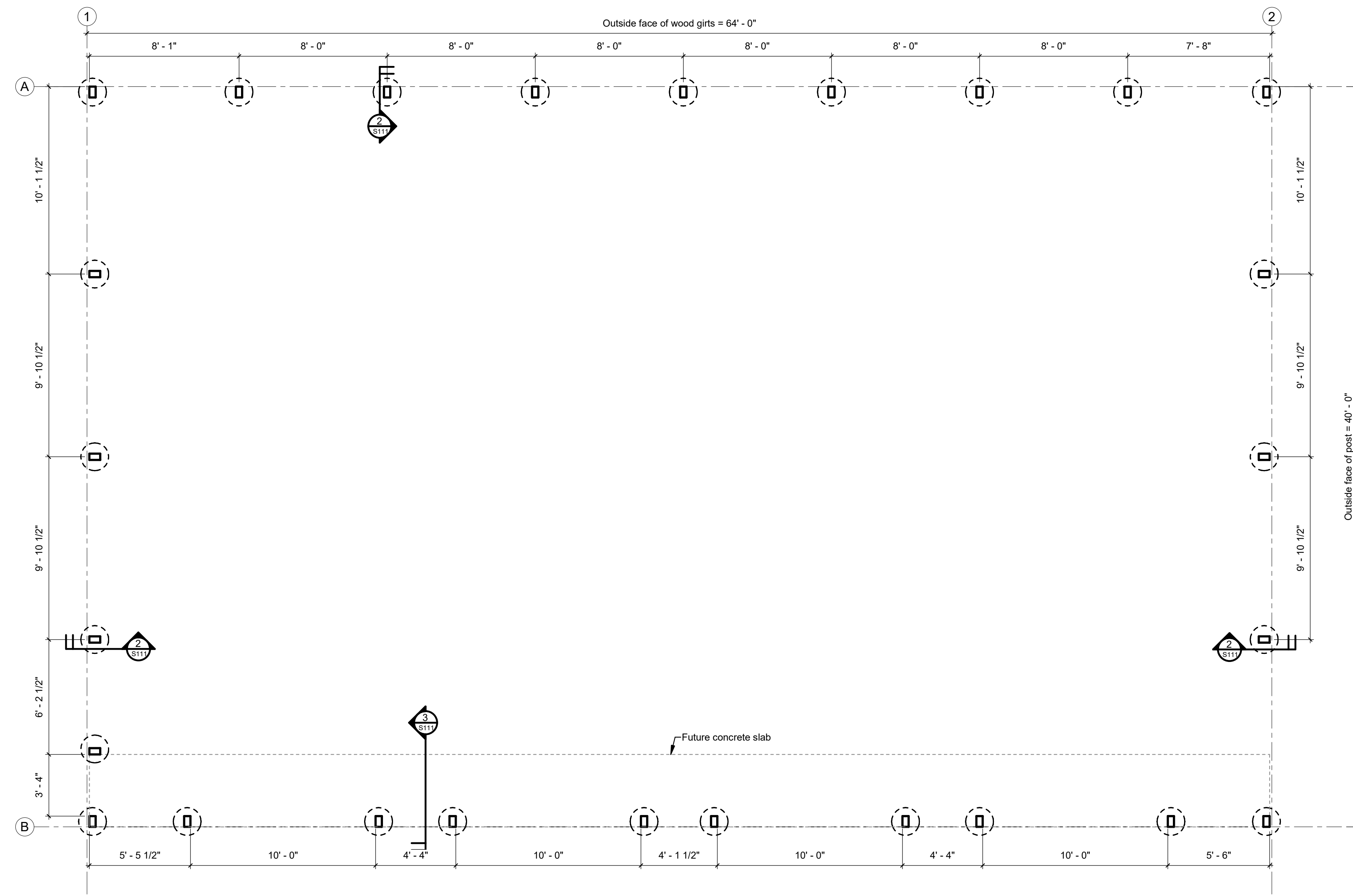

NORTH
 1 Foundation Plan
 S111 1/4" = 1'-0"

Structural Design Loads

Foundation Design Criteria:
 Design allowable soil bearing pressure: 1500PSF
 Verify bearing capacity of soil prior to placement of footings.
 Provide copies of inspection and compacted reports prepared by a qualified geotechnical engineer.

Floor Design Loads (2024 OBC):
 Live Load:
 =100 psf - Slab on grade

Roof Design Loads:
 = 100 psf - Roof
 Minimum Roof Live Load = 20 psf

Snow Load:
 Ground Snow Load, pg = 20.0 psf
 Flat Roof Snow Load, pf = 20.0 psf
 Snow Importance Factor, IS = 1.0
 Thermal Factor, Ct = 1.0
 Exposure Factor, Ce = 1.0

Wind Load:
 Ultimate Wind Speed, Vult = 100 mph
 Basic Wind Speed (3 second gust), V = 90 mph
 Wind Importance Factor, IW = 1.0
 Wind Exposure B
 Internal Pressure Coefficient = +/- 0.18
 MWFRS
 ps30, horizontal = 17.5 psf
 ps30, vertical = 21.5 psf

Seismic Load:
 Occupancy Category II
 SDS = 0.16 Ss = 0.19
 SD1 = 0.10 S1 = 0.072
 Site Soil Class D
 Seismic Design Category B
 Basic Seismic Force Resisting System - Light frame walls with shear panels
 R = 6.5
 IE = 1.0
 Cs = 0.024
 Cd = 4.0
 Equivalent Lateral Force Procedure used in design
 Base Shear, V = 4 Kips

Foundation General Notes

- Bottom of building footings shall be minimum 42" below finished grade.
- Top of floor elevation is 100'-0" unless otherwise noted.
- Subgrade shall be compacted using industry acceptable compacting techniques, to 95% of the maximum density in accordance with ASTM - D698 and at %2 percent of the optimum moisture content as determined by ASTM - D1557.
- Subgrade shall be composed of natural soil and graded rock free of wood, grass, roots, broken concrete, large stones, trash, or debris of any kind.
- Subbase of concrete slab shall be 4" of crushed stone backfill in accordance with ASTM D 2940.

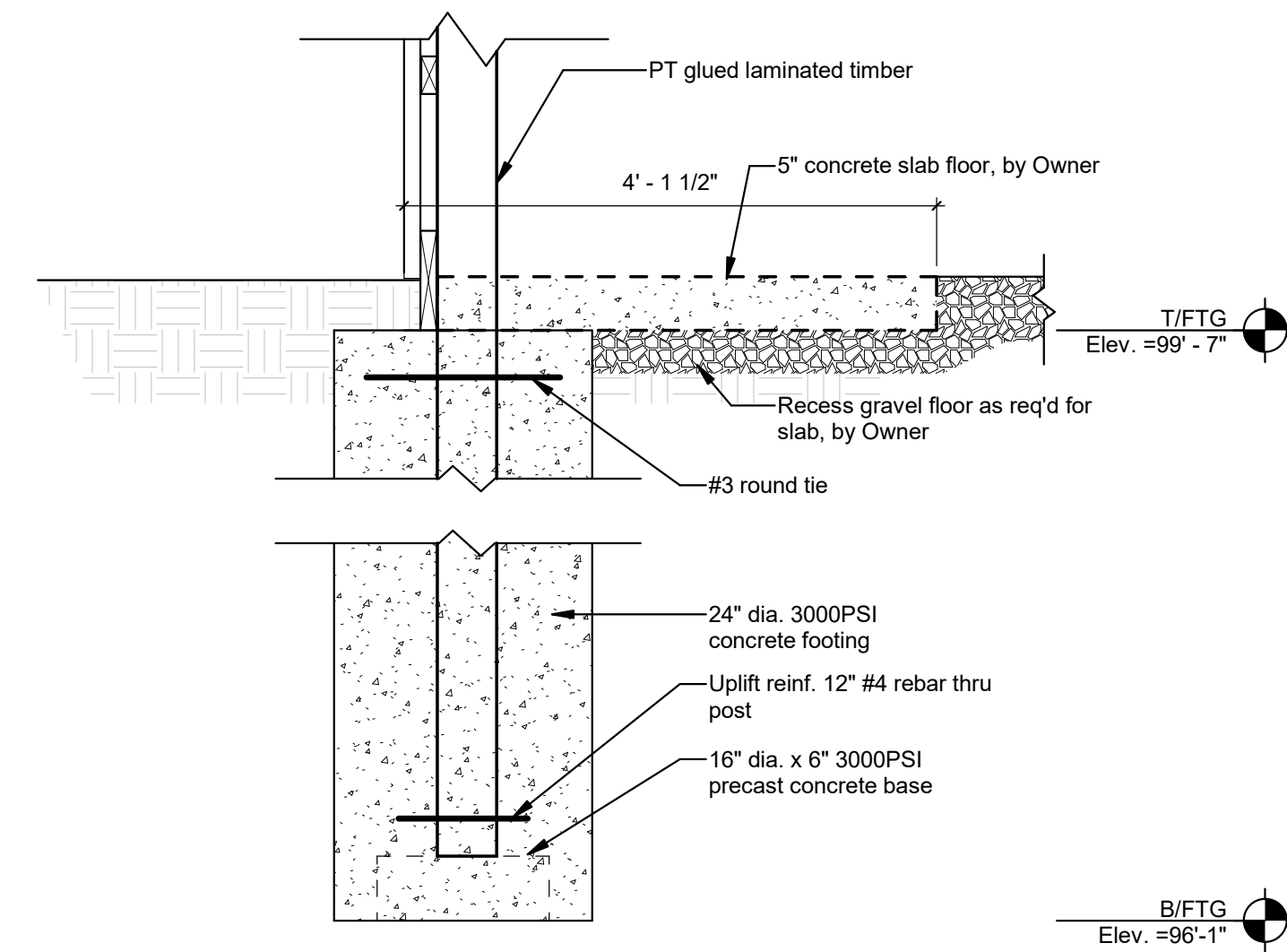

3 Foundation Section
 S111 3/4" = 1'-0"

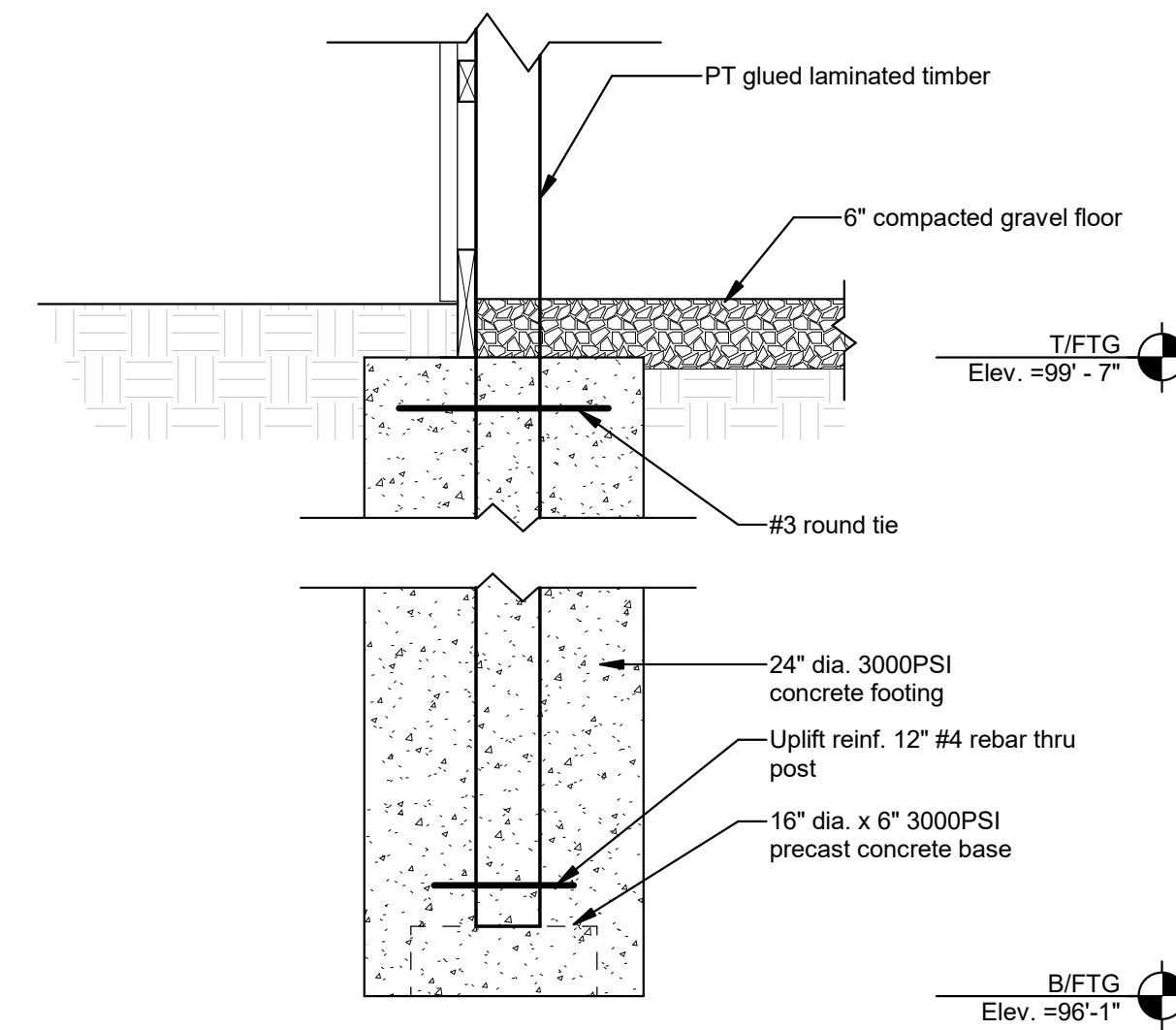

2 Foundation Section
 S111 3/4" = 1'-0"

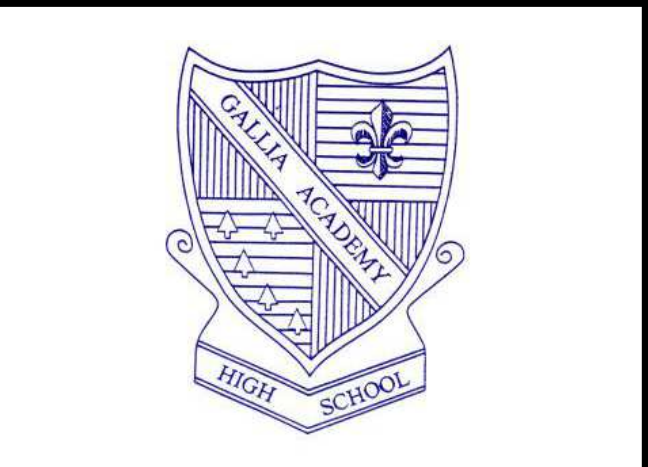

Set Issuance

8/19/25 Construction Documents

Revision

Gallia Storage Shed
 185 Centenary Church Road, Gallipolis, OH 45631
 for
Gallipolis City Schools
 61 State St, Gallipolis, OH 45631

Construction Documents

Not Published
 All Rights Reserved
 This document is the product and exclusive property of the Architect. This document and the information it contains may not be copied or used for other than the specific purpose for which it was prepared without written consent of VSWC Architects.
 Christopher S. Dumford
 License #11547 Exp. Date 12/31/25
 COPYRIGHT © 2025



VSWC Project Number:404-XX

Foundation Plan, Details and Sections

S111

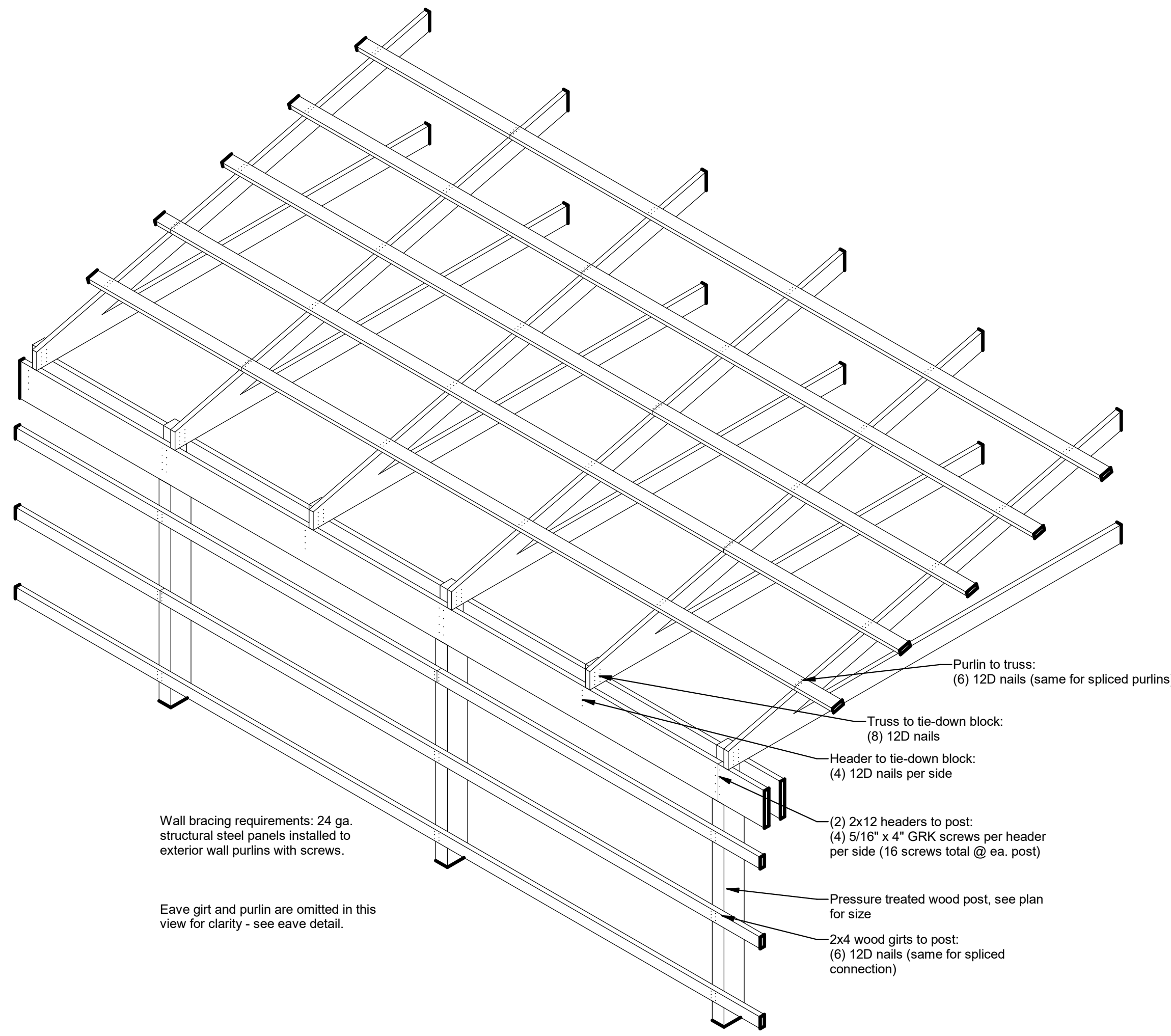

7
S331
Detail
Red'd Attachments

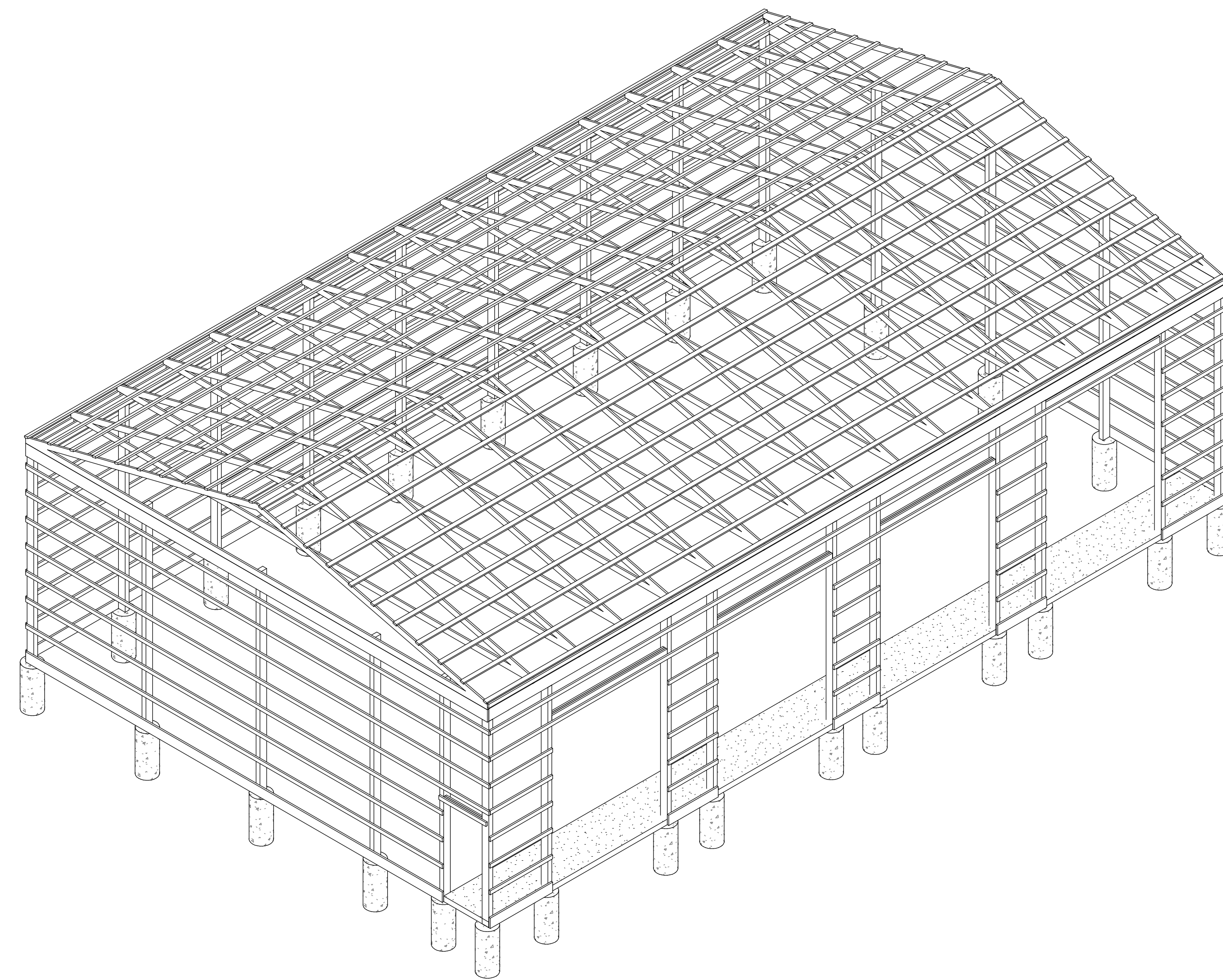

1
S331
Isometric - Building Framing

Framing General Notes

- A. This framing plan is a conceptual representation of the framing assembly. This plan is diagrammatic and does not show every member of construction. Contractor is responsible for supplying all ledgers, blocking, etc. necessary for a complete assembly. Contractor shall field modify all truss tails and/or shim bearing plates as req'd.
- B. All wood trusses to be pre-engineered mono-planar trusses @ 48" o.c. max. and shall have intermediate web members as req'd by the manufacturer. Trusses shall be multi-ply as req'd by the truss manufacturer.
- C. Truss manufacturer shall provide shop drawings (including tabulation of stress analysis) to the Architect (prior to fabrication) bearing the stamp of an Ohio Licensed Professional Engineer. The Engineer's stamp and signature shall appear on each truss type drawing and on all required field fixes. Trusses shall be designed in accordance with applicable building codes.
- D. All misc. framing, blocking, bridging, bracing, etc. shall be #2 or better.
- E. Contractor shall provide temporary bracing as recommended by the Truss Plate Institute (TPI) and as specified by the truss manufacturer.
- F. Contractor shall provide the minimum level of permanent bracing of the roof system (2x4s lapped 2 trusses min.) as indicated below (unless more permanent bracing is req'd by Truss Engineer)
 - a. "X" type bracing (on truss webs) at 15' o.c. measured parallel to trusses and 24' o.c. measured perpendicular to trusses
 - b. Diagonal bracing (on top of bottom chords) at all gable ends; on the inside of all girder trusses; and at intermediate spacing not to exceed 30' unbraced.
 - c. Lateral bracing (on top of bottom chords) continuous perpendicular to all trusses and spaced not to exceed 15' measured parallel to trusses.
- G. Bracing is shown on the plan to clarify, but not limit the bracing specified above. Contractor shall refer to T.P.I. literature for proper installation of all bracing.
- H. Contractor shall provide permanent bracing of truss members as required by the Truss Engineer (as indicated on the Engineered Truss Profile Drawings).
- I. Trusses shall be designed for indicated snow load plus roof structure dead load plus 5 PSF collateral dead load.
- J. All fasteners to be steel.
 - a. Not-dipped galvanized fasteners are required where in contact with pressure-treated lumber.
 - b. All connections to be made per 2024 OBC Table 2304.10.1.
 - c. Add bearing blocks where required for adequate fastener spacing.
- K. Provide Simpson H1 tie-down anchor at each truss.
- L. Provide diagonal bracing at horizontal members of gable end trusses.

Framing Plan Numbered Notes

- 1 Pre-engineered wood truss @ 48" o.c., designed by Truss Engineer.
- 2 PT laminated post 3 ply 2x8.
- 3 (2) 2x12 header, see 4/S331.
- 4 2x truss tie down block @ ea. truss bearing (except where truss can be tied to post). See detail 5/S331.
- 5 Header at overhead door opening: (3) 2x12's w/ (6) 5/16" x 4" GRK screws per header (18 screws total).
- 6 Header at main door opening: (2) 2x6's w/ (3) 12d screws per header (6 screws total).
- 7 2x4 roof purlins @ 24" o.c.
- 9 Permanent bracing design by Truss Engineer. Bracing includes horizontal, diagonal, and cross-bracing. Bracing is shown on plan to clarify, but not limit extent of required bracing.

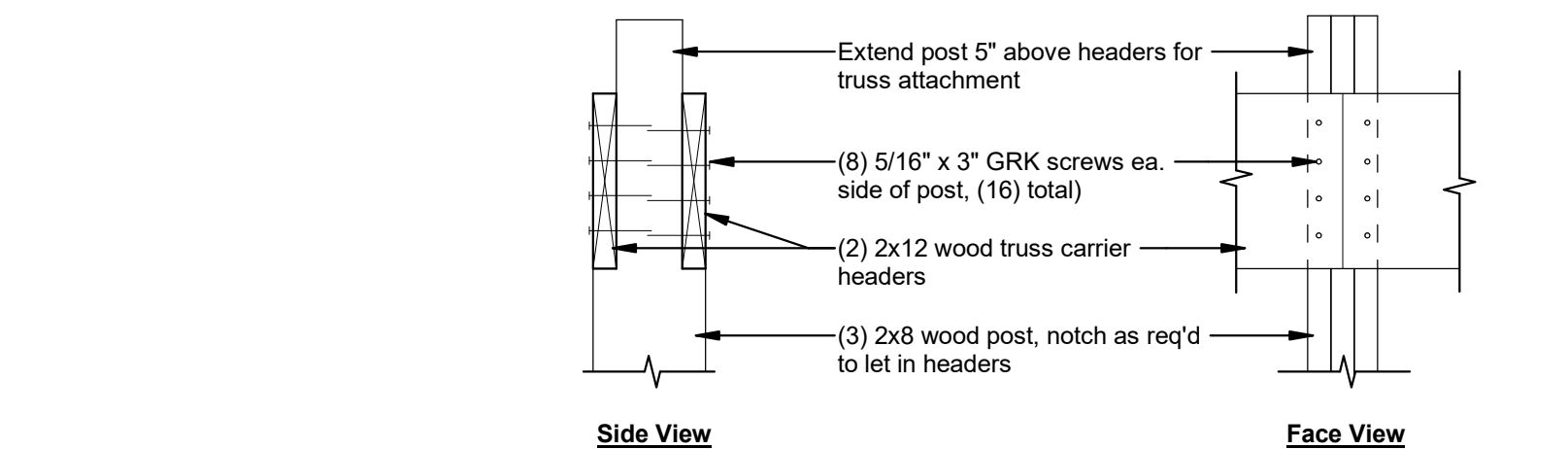

4
S331
Detail
Truss Bearing Header Beam
1" = 1'-0"

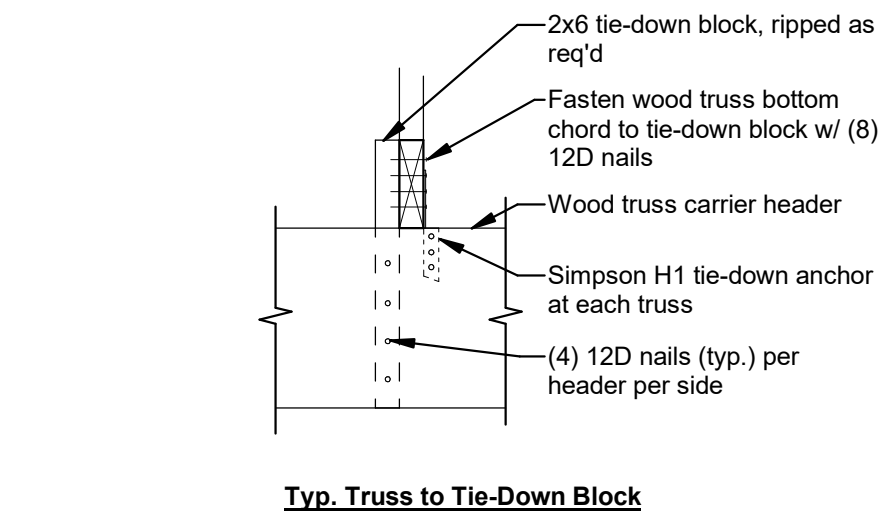

5
S331
Detail
Truss Tie-Downs
1" = 1'-0"

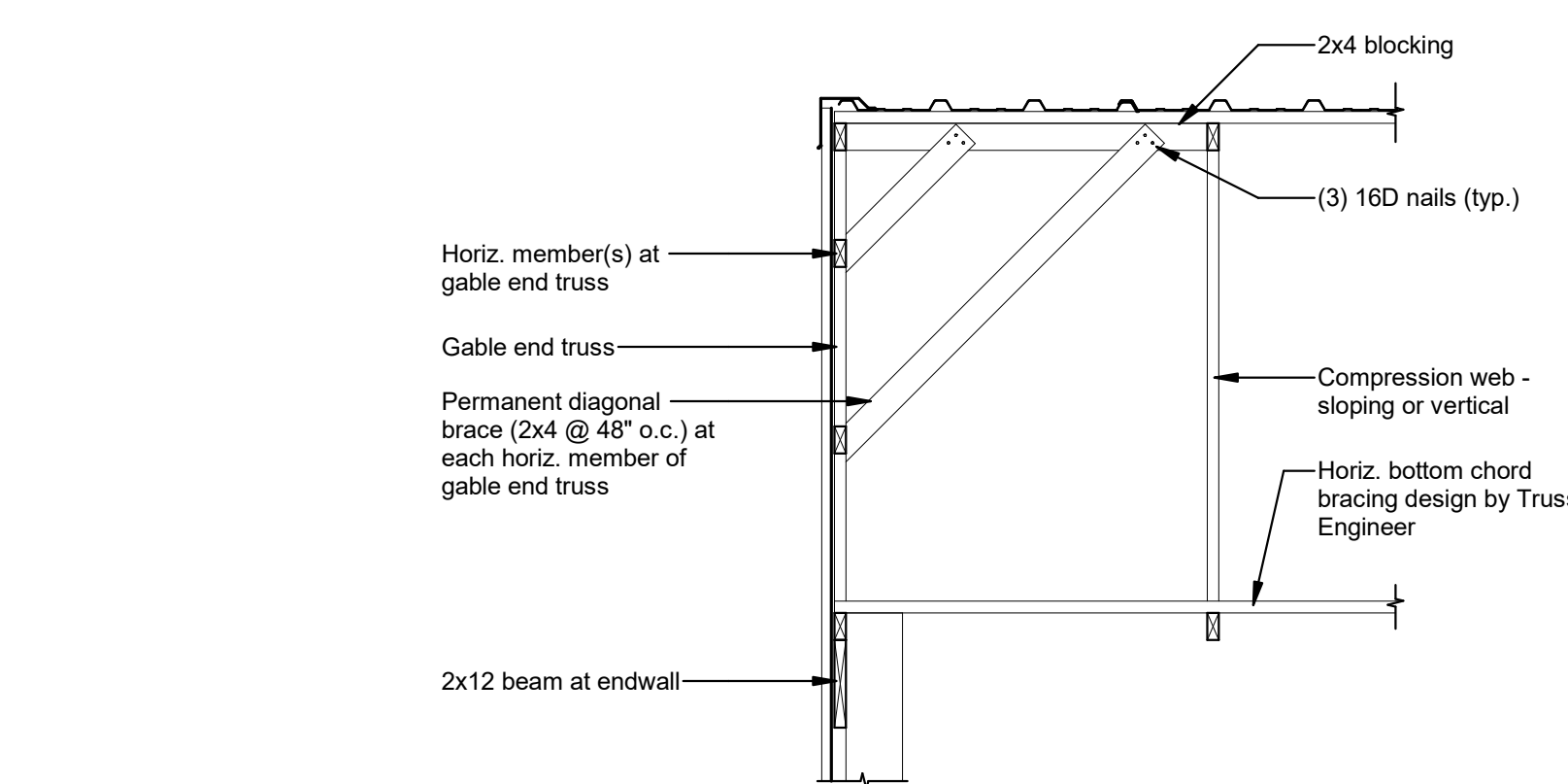

6
S331
Detail
End Truss Diagonal Bracing
1/2" = 1'-0"

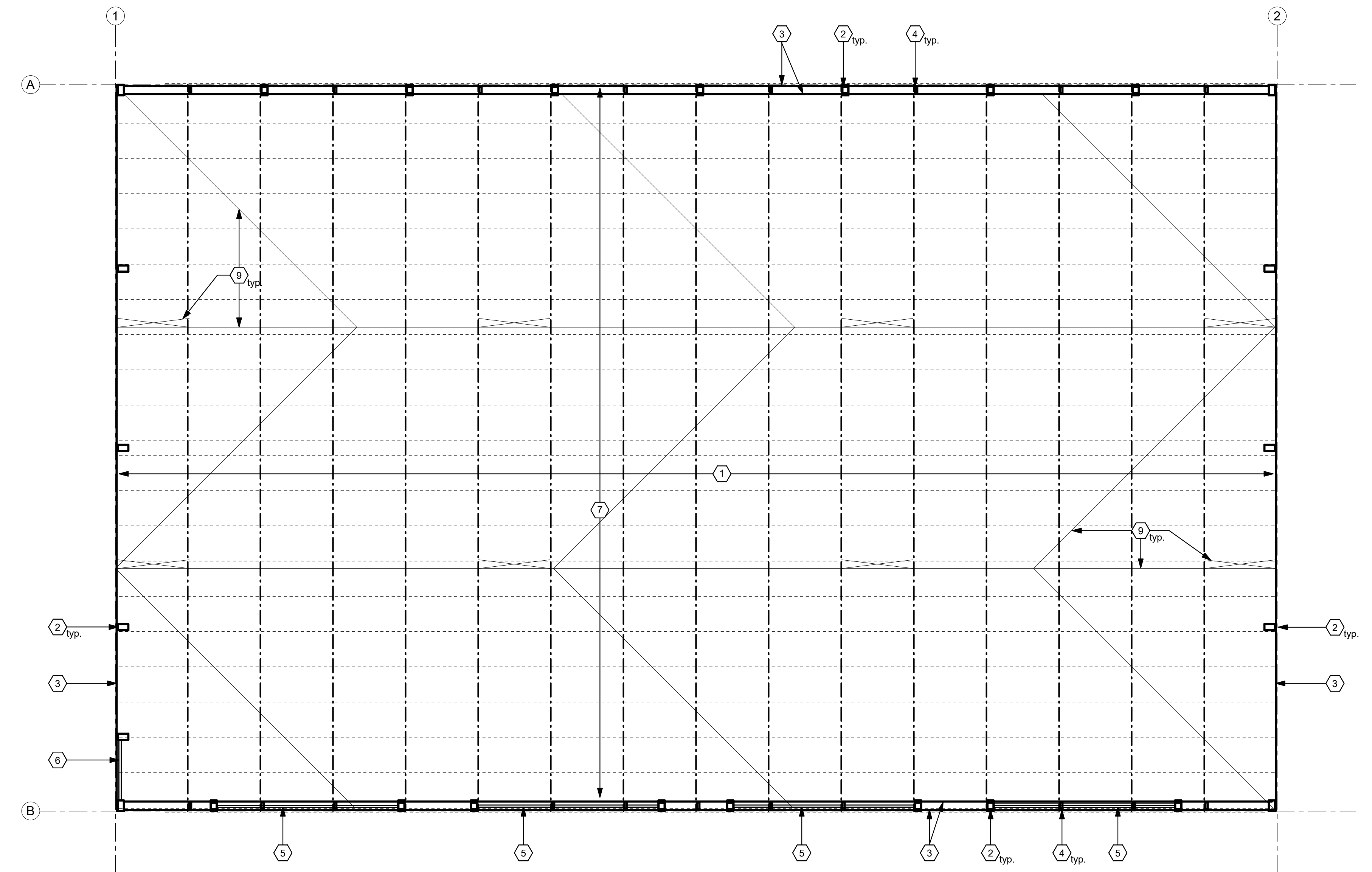

3
S331
Framing Plan
1/4" = 1'-0"

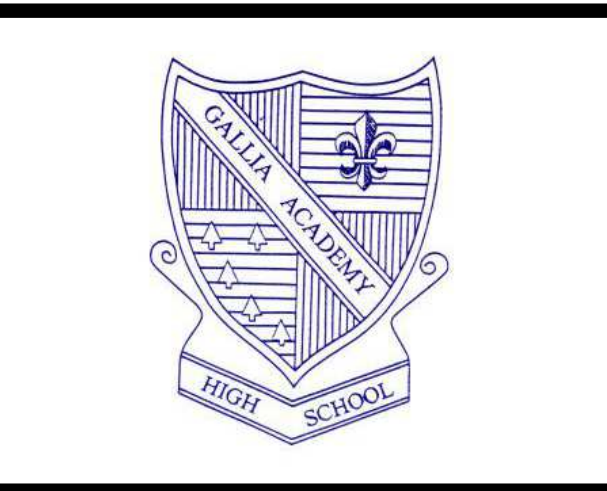

Set Issuance
8/19/25 Construction Documents

Revision

Gallia Storage Shed
185 Centenary Church Road, Gallipolis, OH 45631
for
Gallipolis City Schools
61 State St, Gallipolis, OH 45631

Construction Documents

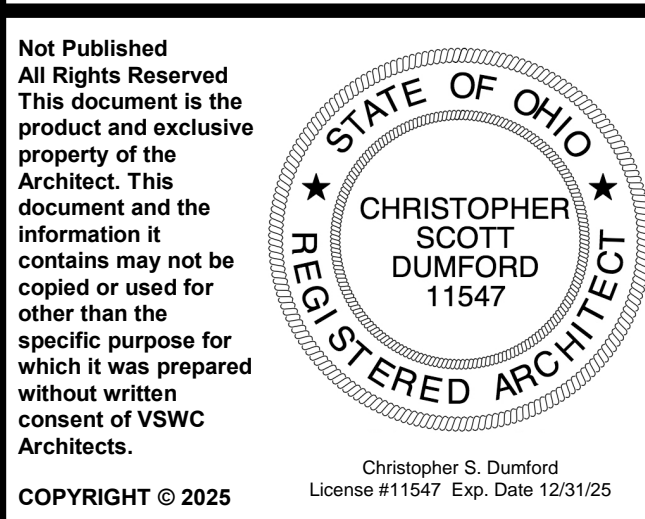

VSWC Project Number:404-XX

Framing Plan and Details
S331

Attachment 2

PROPOSAL FORM

Attachment 2: Proposal Form

Proposer's Name: _____

Proposer's Address: _____

Principal Contact: _____

Telephone Number: _____

Email Address: _____

Federal Tax ID Number: _____

Date Submitted: _____

Article 1 — Pricing Proposal

1.1 The Proposer will perform all Work identified in the Request for Proposals ("RFP") and its Attachments for the **Gallia Storage Shed Project** (the "Project"), if any, for the lump sum of:

_____ Dollars (\$ _____)
(Words) (Figures)

Article 2 — Addenda

2.1 Receipt of the following Addenda is hereby acknowledged:

Addendum No. _____	Date: _____
Addendum No. _____	Date: _____
Addendum No. _____	Date: _____

Article 3 — Proposer's Certifications

3.1 Proposer hereby acknowledges that the following representations in this Proposal are material and not mere recitals:

3.1.1 Proposer has read and understands the RFP and its Attachments and agrees to comply with all their requirements.

3.1.2 Proposer represents that the Proposal is based upon the RFP and its Attachments, including but not limited to any drawings and specifications provided.

3.1.3 Proposer has visited the Project site, become familiar with local conditions and has correlated personal observations about the requirements of the RFP and its Attachments. Proposer has no outstanding questions regarding the interpretation of the RFP and its Attachments based upon what it has observed and could reasonably have been expected to have observed.

3.1.4 Proposer has carefully reviewed the Project site, and any drawings and specifications that have been provided to become familiar with the requirements for the Work and has included all costs necessary to provide labor and materials for the Work in this Proposal, including incidentals, whether or not specifically called for and to become familiar with the limitations and conditions related to the

Work covered by the Proposal and has included in this Proposal, a sum to cover the cost of such items.

3.1.5 Proposer and each person signing on behalf of Proposer certify, and in the case of a joint or combined proposal, each party thereto certifies as to such party's organization, under penalty of perjury, that to the best of the undersigned's knowledge and belief:

3.1.5.1 the Proposal amount, any Unit Prices and any Alternate items in the Proposal have been arrived at independently without collusion, consultation, communication or agreement, for the purpose of restricting competition as to any matter relating to such Base Proposal, Unit Prices or Alternate Items with any other Proposer;

3.1.5.2 unless otherwise required by law, the Proposal amount, any Unit Prices and any Alternate items in the Proposal have not been knowingly disclosed by the Proposer and will not knowingly be disclosed by the Proposer prior to the proposal opening, directly or indirectly, to any other Proposer who would have any interest in the Proposal amount, Unit Prices or Alternate items; and

3.1.5.3 no attempt has been made or will be made by the Proposer to induce any other individual, partnership or corporation to submit or not to submit a proposal for the purpose of restricting competition.

3.1.5.1 the Proposer is not the subject of an unresolved finding for recovery issued by the Auditor of State under ORC Section 9.24 or that Proposer has taken the appropriate remedial steps required under Section 9.24, ORC, or otherwise qualifies under this section;

3.1.5.2 the Proposer is not debarred under ORC Section 153.02;

3.1.5.3 the Proposer has not been found by a court to be in default of a judgment or breach of settlement agreement; and

3.1.5.4 the Proposer has not violated ORC Section 3517.102 by exceeding allowable campaign contributions.

3.1.6 Proposer will negotiate and enter into an agreement with the private financial institution financing the Project, if an agreement is awarded on the basis of this Proposal.

3.1.7 Proposer certifies that the upon the award of an agreement, the Proposer will make a good faith effort to ensure that all of the Proposer's employees, while working on the site of the Project, will not purchase, transfer, use or possess illegal drugs or alcohol or abuse prescription drugs in any way.

3.1.8 Proposer agrees to furnish any information requested by the Owner to evaluate the experience, resources, and qualifications of the Proposer.

Signed and Submitted:

Proposer's Name

By: _____
Signature

Printed Name & Title

Date

Attachment 3

FORM OF AGREEMENT WITH EXHIBITS

OWNER-CONTRACTOR AGREEMENT

Owner:

**Gallipolis City School District Board of Education
61 State Street
Gallipolis, Ohio 45631**

Project: Gallia Storage Shed Project

Location:

**Near Bus Garage
160 Centenary Church Road
Gallipolis, OH 45631**

Contractor:

Contact: _____

Phone: _____

Email: _____

Owner, a political subdivision of the State of Ohio, and Contractor have entered into this Owner-Contractor Agreement ("Agreement") and is effective the date the Agreement is signed by the Owner. The competitive bidding requirements for school districts outlined in O.R.C. Section 3313.46 do not apply to the procurement of the Contractor for the Project as the cost of the Project is less than the amount specified in O.R.C. Section 9.17.

The Project Owner and Contractor agree as follows:

1. WORK.

1.1. Contractor will furnish all the labor, services, materials, plant, equipment, tools, scaffolds, appliances, and all other things (collectively called the "Work") necessary for the timely and proper completion of the Project.

1.2. Contractor must at all times furnish sufficient skilled workers, materials, and equipment to perform the Work in strict conformance with the Contract Documents and to the entire satisfaction of Owner, so as to complete the Project by the Date for Substantial Completion. All materials and equipment provided must be new, free from all defects, fit for the purpose for which intended, and merchantable.

1.3. Contractor will assign a competent Project Supervisor. At the Owner's request, Contractor will replace the Project Supervisor, provided that the request is reasonable. Owner will not be responsible for the acts or omissions of the Project Supervisor or his assistants.

1.4. Contractor shall be responsible for cutting, fitting, or patching required to complete the Work or it make its parts fit together properly.

2. CONTRACT DOCUMENTS.

2.1. The Contract Documents consist exclusively of the following documents incorporated by reference:

- A. Public Notice;
- B. Request for Proposals;
- C. Contractor's Proposal (as modified and attached to this Agreement);
- D. Owner-Contractor Agreement, including all exhibits attached hereto;
- E. Drawings prepared by VSWC Architects;
- F. Sales & Use Tax/ Construction Contract Exemption Certificate;
- G. Addenda issued;
- H. Modifications issued after the execution of the contract, including:
 - a. A written amendment to the Agreement signed by both parties;
 - b. A Change Order; or
 - c. A Construction Change Directive

2.2. Contractor will use the State of Ohio Subcontract Form for all subcontracted Work, in accordance with ORC Section 153.503(C) and OAC Section 153:1-3-02.

2.3. Unless otherwise stated in the Contract Documents, words that have well-known technical or construction industry meanings are used in the Contract Documents in accordance with such recognized meanings. Days shall mean calendar days unless noted otherwise.

3. OWNER REPRESENTATIVE AND DESIGN PROFESSIONAL.

3.1. Design Professional. The Design Professional for this Project is VSWC Architects. The Design Professional prepared the drawings for the Work. The Design Professional will also provide construction administration services for the Project. The Contractor will coordinate with the Design Professional, as instructed by the Owner.

3.2. Craig Wright, Superintendent, is the Owner's Representative with respect to all matters involving Owner.

3.2.1. Except as specifically stated to the contrary elsewhere in this Agreement, Contractor will direct all communications to Owner through the Owner's Representative.

3.3. Contractor will coordinate the Work with the Owner and Owner's separate contractors, consultants, or other agents. Contractor will provide access to the Work at all times.

4. TIME FOR COMPLETION AND PROJECT COORDINATION.

4.1. Contract Time. The Work shall commence as of the Effective Date of this Agreement (the "Date of Commencement"), with all associated Work being completed on or before **February 15, 2026** (the "Date for Substantial Completion").

4.1.1. Substantial Completion. Substantial Completion is the stage in the progress of the Work when the Work or designated portion thereof is sufficiently complete in accordance with the Contract Documents so that the Owner can occupy or utilize the Work for its intended use. Notwithstanding anything in the Contract Documents to the contrary, this shall include, but is not limited to, start up and successful testing of all systems and equipment. For purposes of releasing retainage in accordance with Ohio Revised Code 153.13, Substantial Completion shall not be effective until a certified payment application for release of such retainage has been received by Owner.

4.1.2. Within thirty days Substantial Completion of the Work or a designated portion thereof, as certified by the Design Professional or confirmed by the Owner, and Owner's receipt of consent of the Contractor's surety, if any, the Owner shall make a payment of retainage applying to such Work and any interest thereon accrued. Such payment shall be adjusted for Work that is incomplete or not in accordance with the requirements of the Contract Documents. The Owner is entitled to withhold 200% of the value of such incomplete or nonconforming Work as necessary to assure Final Completion, per Ohio Revised Code 153.13.

4.1.3. Date of Final Completion. Final Completion shall mean that the Work is complete in all respects in accordance with the Contract Documents and the Contractor has submitted to the Owner all required documents. The date of Final Completion shall be within **14** calendar days from the Date of Substantial Completion.

4.2. Time is of the Essence. THE DATES IN THE CONTRACT DOCUMENTS ARE OF THE ESSENCE OF THIS AGREEMENT. CONTRACTOR WILL PROSECUTE ITS WORK IN ACCORDANCE WITH THE CONTRACT DOCUMENTS, INCLUDING ANY AMENDMENTS THERETO.

4.3. Contractor's Construction and Submittal Schedules

4.3.1. The Contractor shall prepare for Owner's review and approval the construction schedule ("Construction Schedule") and a corresponding detailed schedule of values pursuant to the Ohio Revised Code Section 153.13 within seven (7) calendar days after the Effective Date. The schedule of values must be broken out into labor and materials for each line item. The Contractor shall prepare the Construction Schedule in Critical Path Method ("CPM") format unless provided otherwise in the Contract Documents or otherwise in writing by the Owner. Each major category of Work shall be shown separately in the Construction Schedule with all the significant activities involved, showing durations of time, manpower requirements, and restraints. The Construction Schedule is for the purpose of coordinating the timing, phasing, and sequence of the Work of the Contractor and shall not change or modify the Date for Substantial Completion. The Date for Substantial

Completion shall only be changed or modified by Change Order, other Modification, or a Claim that is Finally Resolved, regardless of the dates in the Construction Schedule.

4.3.1.1. The Contractor shall update the Construction Schedule each month;

4.3.1.2. The Construction Schedule shall be manpower loaded;

4.3.1.3. The Contractor shall, on a weekly basis, prepare and submit to the Owner a written report describing the activities begun or finished during the preceding week, Work in progress, expected completion of the Work, a look-ahead projection of all activities to be started or finished in the upcoming two (2) weeks, including without limitation the Contractor's workforce crew size and total resource hours associated with such Work and any other information requested;

4.3.1.4. The float in the Construction Schedule and any updates to it shall belong to the Owner. Float shall mean the amount of time by which activities may be delayed without affecting the Date for Substantial Completion; and

4.3.1.5. The Contractor's obligation to submit requested scheduling information is a material term of its Contract. If the Contractor fails to submit requested scheduling information in writing within five (5) days of a request for such information from the Owner, the Contractor shall pay and the Owner may withhold from the Contractor Liquidated Damages at the rate of Fifty Dollars (\$50.00) a day for each calendar day thereafter that the Contractor fails to submit the requested information.

4.3.2. The Contractor shall perform the Work in accordance with the most recent Construction Schedule submitted to the Owner, provided that the Contractor shall comply with any orders under Section 4.3.3. However, preparation of such schedule shall not constitute a waiver of the Owner's rights under the Contract to have the Work completed by the Date for Substantial Completion.

4.3.3. If the Owner determines that the performance of the Work has not progressed so that it is likely that the Contractor will not achieve Substantial Completion of its Work by the Date for Substantial Completion, the Owner shall have the right to order the Contractor to take corrective measures necessary to expedite the Work, including, without limitation: (i) working additional shifts or overtime; (ii) supplying additional manpower, equipment, and facilities, and (iii) other similar measures ("Corrective Measures"). If the Owner orders the Contractor to take such corrective measures, the Contractor shall take and continue such Corrective Measures until the Owner is satisfied that the Contractor is likely to achieve Substantial Completion of its Work by its Date for Substantial Completion.

4.3.3.1. The Contractor shall not be entitled to adjustment in the Contract Sum in connection with the Corrective Measures required by the Owner pursuant to this Section 4.3.3, unless the Contractor is able to establish that it is entitled to additional compensation under the terms of the Contract Documents.

4.4. Delays and Accelerations.

4.4.1. Notice of Delays. Contractor will give Owner written notice of any delay affecting its Work in the form and with the information specified in the Contract Documents within forty-eight (48) hours of the commencement of the delay; provided that the 48-hour notice will be extended to ten (10) days for unusually severe weather conditions not reasonably anticipatable. The failure to give the required notice constitutes an irrevocable waiver of Contractor's right to seek an extension of time and/or additional compensation/damages for the delay.

4.4.2. Acceleration of the Work. Owner may require Contractor to accelerate its Work by adding workers or working additional shifts, extended shifts or overtime, so that the Work is in final form before the Date for Substantial Completion. If Owner requires Contractor to accelerate its Work, Contractor will within five (5) days take the required action, and Owner thereafter will issue a Change Order increasing the Contract Sum to pay for Contractor's additional costs of accelerating its Work so that the Work is in final form before the Date for Substantial Completion. If there is a dispute as to whether Contractor is entitled to a Change Order for accelerating its Work, Contractor must proceed to accelerate its Work without waiting for a Change Order or payment of any additional compensation, but may reserve its right to make a claim against Owner for its additional costs incurred in accelerating its Work. Contractor's additional costs for accelerating its Work will be determined in accordance with Section 4.4.3.

4.4.3. Compensation for Acceleration of the Work.

4.4.3.1. Owner's Obligation to Pay. When Owner initiates the acceleration of the Work, Owner will pay Contractor, as provided in Section 4.4.3.2, for Contractor accelerating its Work so that its Work is substantially complete by the Date for Substantial Completion. However, when Contractor's Work is ordered to be accelerated as a result of Contractor's own fault or the fault of its subcontractors or suppliers, Owner will not pay Contractor for such acceleration.

4.4.3.2. Compensation for Acceleration of the Work. To the extent that Owner requires Contractor to accelerate its Work so that the Work is in final form before the Date for Substantial Completion, Owner will pay Contractor for Contractor's reasonable additional costs of accelerating its Work, as determined in accordance with this section. The additional costs of accelerating the Work will be (a) any premium for overtime, additional shift work, or extended shift work, (b) the cost of any additional supervision or general conditions required by the acceleration, (c) out of pocket cost of any additional equipment required for the acceleration, (d) to the extent Contractor can document lost productivity due to the acceleration, the cost associated with such lost productivity, and (e) overhead, including home office overhead, and profit equal to 10% of the total amount of the other items for which additional compensation is permitted under this section. The foregoing are the only additional compensation and/or damages Contractor will be entitled to receive for accelerating its Work so that it is complete before the Date for Substantial Completion. As a condition precedent to its recovery of additional compensation, Contractor must provide Owner with full information about the costs of accelerating its Work in the form and format requested by Owner.

5. CORRECTIVE ACTION.

5.1. If Owner determines that Contractor is in default by not cooperating or coordinating its Work properly with its subcontractors, not supplying sufficient skilled workers, not cleaning up the Project, not furnishing the necessary materials, equipment, or any temporary services or facilities to perform the Work in strict conformance with the Contract Documents, or Contractor is not on schedule, or is not otherwise performing its obligations under the Contract Documents, CONTRACTOR MUST WITHIN TWO (2) BUSINESS DAYS AFTER NOTICE OF SUCH DETERMINATION, (1) COMMENCE SUCH ACTION AS IS NECESSARY TO CORRECT THE DEFICIENCIES NOTED BY OWNER, (2) PROCEED TO CORRECT SUCH DEFICIENCIES WITHIN FIFTEEN (15) DAYS OF SUCH NOTICE OR, (3) IF OWNER INSTRUCTS CONTRACTOR TO TAKE URGENT CORRECTIVE ACTION TO PROTECT PERSONS OR PROPERTY, IMMEDIATELY TAKE SUCH CORRECTIVE ACTION, including but not limited to increasing the number of skilled workers, providing temporary services or facilities, and cleaning up the Project. Such corrective action shall be taken and continued without interruption and without waiting to initiate any dispute under this Agreement or the resolution of any dispute initiated under this Agreement. Failure to comply with this provision shall be an additional default.

6. COMPENSATION.

6.1. Contract Sum. The Contract Sum to be paid by Owner to Contractor, as provided herein, for the satisfactory performance and completion of the Work and all of the duties, obligations and responsibilities of Contractor under this Agreement and the other Contract Documents is \$_____. The Contract Sum includes the following:

6.1.1. Base Proposal Amount: \$_____ (Lump Sum Bid)

6.1.2. [Not Used.]

6.1.3. [Not Used.]

6.1.4. [Not Used.]

6.2. The Contract Sum includes all federal, state, county, municipal, and other taxes imposed by law, including but not limited to any sales, use, and personal property taxes payable by or levied against Contractor on account of the Work or the materials incorporated into the Work. Contractor is responsible to pay any such taxes.

6.3. The Contract Sum includes fees and costs for any required building permit as well as other permits, fees, licenses, and inspections by government agencies necessary for proper execution and completion of the Work

that are customarily secured after execution of the Contract and legally required at the time negotiations are concluded. Contractor is responsible to secure any such permits, fees, licenses, and inspections.

6.4. Liquidated Damages.

6.4.1. Contractor must achieve Substantial Completion by the date stated in Section 4.1 and Final Completion by the date stated in Section 4.1.3. By entering into this Agreement, Contractor agrees that the period for performing the Work is reasonable and that Contractor can achieve Substantial Completion and Final Completion by the dates identified in this Agreement.

6.4.2. Liquidated Damages for Substantial Completion. If Contractor does not achieve Substantial Completion of all of its Work on the Project by the Date for Substantial Completion stated in Section 4.1, Contractor shall pay the Owner (and the Owner may set off from sums coming due Contractor) liquidated damages in the per diem amount stated in the following chart for each calendar day beyond the Date for Substantial Completion, as may be modified in accordance with the Contract Documents, that the Contractor fails to achieve Substantial Completion.

Contract Sum Amount	Dollars Per Day
\$0.01 to \$50,000.00	\$100.00
\$50,000.01 to \$150,000.00	\$200.00
\$150,000.01 to \$500,000.00	\$300.00
\$500,000.01 to \$750,000.00	\$400.00
\$750,000.01 to \$1,000,000.00	\$500.00
\$1,000,000.01 to \$2,000,000.00	\$700.00
More than \$2,000,000.00	\$1,000.00

6.4.3. Liquidated Damages for Final Completion. If Contractor does not achieve Final Completion of all of its Work on the Project by the date of Final Completion stated in Section 4.1.3, Contractor shall pay the Owner (and the Owner may set off from sums coming due Contractor) liquidated damages in the per diem amount stated in the following chart for each calendar day beyond the Date of Final Completion, as may be modified in accordance with the Contract Documents, that the Contractor fails to achieve Final Completion.

Contract Sum Amount	Dollars Per Day
\$0.01 to \$50,000.00	\$50.00
\$50,000.01 to \$150,000.00	\$100.00
\$150,000.01 to \$500,000.00	\$150.00
\$500,000.01 to \$750,000.00	\$200.00
\$750,000.01 to \$1,000,000.00	\$250.00
\$1,000,000.01 to \$2,000,000.00	\$350.00
More than \$2,000,000.00	\$500.00

6.4.4. Contractor acknowledges by signing this Agreement with Owner that the amounts of liquidated damages represent a reasonable estimate of the actual damages Owner would incur if the Work is not substantially complete or finally complete by the foregoing dates and that the damages that may result from the failure to substantially complete or finally complete the work by the foregoing dates are uncertain and difficult to ascertain. No waiver of consequential damages shall preclude the Owner from recovering liquidated damages. In the event Contractor fails to achieve Substantial Completion by the date of Final

Completion, Contractor shall accrue liquidated damages for both Substantial Completion and Final Completion until each respective date is met.

6.4.5. Nothing in this Section 6.4 shall preclude the Owner from recovering its actual damages from the Contractor for third-party claims against the Owner or damages not associated with delay.

7. PAYMENT AND RETAINAGE.

7.1. Payment.

7.1.1. Applications for Payment. Payment applications shall be submitted on a monthly basis and shall reflect the amount of Work completed as of the date the application for payment is submitted consistent with the schedule of values. Payment applications must be received by the Owner not later than the fifteenth (15th) day of the month; payment applications received after the 15th day of the month will be deemed to be received in the following month and will be held for payment during the following payment period. With each application for payment the Contractor shall submit one copy of the following documentation:

- (a) Invoice for Work performed and materials and equipment provided for the previous pay period;
- (b) If required for the Project, the Certified Payroll Report for payment of prevailing wages;
- (c) Lien waivers from itself and all subcontractors, suppliers, and any other party that performed Work or supplied materials for the Project in a form acceptable to the Owner for the Work performed during the current billing period; and
- (d) Such other supplemental information as the Owner may require. Such other information may include a schedule of all materials and equipment stored on site.

7.1.2. Owner may withhold payment in whole or in part, and may demand that Contractor refund amounts previously paid, to protect Owner from loss because of:

- (a) Contractor's default or failure to perform any of its obligations under the Contract Documents, including but not limited to: failure to provide sufficient skilled workers; Work, including equipment or materials, which is defective or otherwise does not conform to the Contract Documents; failure to conform to the Contract Time or Construction Schedule; and failure to follow the directions of or instructions from Owner;
- (b) Contractor's default or failure to perform any of its obligations under another contract that it has with Owner;
- (c) The filing of third party claims, or reasonable evidence that third party claims have been or will be filed;
- (d) The Work has not proceeded to the extent set forth in the application for payment;
- (e) Any representations made by Contractor are untrue;
- (f) The failure of Contractor to make payments to its Subcontractors;
- (g) Damage to Owner's property or the property of another person or laborer;
- (h) The determination that there is a substantial possibility that the Work cannot be completed for the unpaid balance of the Contract Sum; and/or
- (i) Liens filed or reasonable evidence indicating the probable filing of such liens.

7.1.3. Owner will pay Contractor within thirty (30) days after receipt of the Contractor's certified payment application, provided that the payment application has been properly submitted on a timely basis and is accompanied by all of the required documentation and certified by the Design Professional or Owner. Amounts unpaid after thirty (30) days after Owner's receipt of the payment application shall bear interest at the rate of zero percent (0%).

7.2. Retainage.

7.2.1. Amount of Retainage.

7.2.1.1. Payments for Labor. Payments for labor incorporated into the Work will be at the rate of 96% of the amount set forth in Contractor's payment application and approved by Owner, unless the parties agree otherwise.

7.2.1.2. Payments for Materials and Equipment. Payments for materials and equipment will be at the rate of 92% of the invoice cost of materials and equipment delivered to the Project site or other storage site approved by Owner. The balance of the invoice cost will be payable when the materials or equipment are incorporated into the Work. Incorporated into the Work means such materials and equipment are installed and conform to the requirements of the Contract Documents. When payment is made on account of materials or equipment not yet incorporated into the Project, such materials and equipment will become the property of Owner; provided that if such materials or equipment are stolen, destroyed, or damaged before being fully incorporated into the Project, Contractor shall be required to replace them at its expense.

7.2.1.3. No Subcontractor shall be paid at a rate lower than the rate being paid to the Contractor by the Owner.

7.2.2. Interest on Retainage.

7.2.2.1. Contractor agrees that Owner may hold retained amounts in the project construction fund and is not required to deposit the retained funds into a separate interest-bearing savings account. The balance of the retained funds, plus any interest, will be paid to Contractor within thirty days of Final Completion of the Project, as its final payment for the Project, less any amounts needed to cover damages or costs incurred by Owner related to the Work.

7.2.3. Documentation. Upon request, Contractor immediately will supply Owner with requested information so as to verify the amounts due to Contractor, including but not limited to original invoices for materials and equipment and documents showing that Contractor has paid for such materials and equipment, and so as to verify that amounts due laborers, subcontractors, and materialmen have been paid to them.

7.3. Final Payment.

7.3.1. The final application for payment shall be itemized and submitted after completion of the Work specified for the Project. Contractor shall ensure that the final application for payment shall contain one (1) copy of each of the following documents, if not previously delivered to Owner.

- (a) All items required in Section 7.1.1;
- (b) Contractor's Certificate of Insurance;
- (c) Contractor's Workers' Compensation Certificate;
- (d) Consent of Contractor's Surety to Payment;
- (e) An assignment to Owner of all warranties obtained or obtainable by Contractor from manufacturers and suppliers of equipment and materials incorporated into the Work by written instrument of assignment in a form acceptable to Owner; and
- (f) Such other documentation as required by the Contract Documents, Owner, or applicable law, including but not limited to, the final certified payroll report and required Affidavit of Compliance if Prevailing Wages are required for the Project.

7.3.2. The making of Final Payment by Owner does not constitute a waiver of Claims by Owner for the following:

- (a) Liens, Claims, security interests, or encumbrances arising out of the Contract Documents that are unsettled;

- (b) Failure of the Work to comply with the requirements of the Contract Documents;
- (c) Terms of warranties required by the Contract Documents;
- (d) Claims for Indemnification;
- (e) Claims about which Owner has given Contractor notice; or
- (f) Claims arising after Final Payment.

8. CHANGES IN THE WORK.

8.1. Change Orders.

8.1.1. A Change Order is a written instrument signed by Owner and Contractor stating their agreement upon a change in the Work, the amount of the adjustment or the method for computing the amount of the adjustment of the Contract Sum, if any, and the extent of the adjustment in the Contract Time, if any.

8.1.2. All Change Orders shall be submitted with any supporting documentation requested by the Owner in advance of the performance of the Work that is the subject of the Change Order and must be approved by the Owner in writing in advance of the performance of the Work that is the subject of the Change Order.

8.1.3. The agreement on any Change Order shall constitute a final settlement of all matters relating to the change in the Work that is the subject of the Change Order, including but limited to all direct, indirect, and cumulative costs that include reasonable overhead and profit associated with such change and any and all adjustments to the Contract Sum and in the Contract Time. Total cumulative overhead and profit for Contractor and all Subcontractors on any add or deduct Change Order shall not exceed 15% of the total cost of labor and material. The Contractor shall not proceed with any change in the Work without a signed Change Order. The Contractor's failure to timely seek and obtain such authorization as specified herein, shall constitute an irrevocable waiver by the Contractor of an adjustment to the Contract Sum or the Contract Time for the related work.

8.2. Construction Change Directives.

8.2.1. A Construction Change Directive is a written order prepared and signed by the Owner, directing a change in the Work prior to agreement on adjustment, if any, in the Contract Sum or Contract Time, or both. The Owner may by Construction Change Directive, without invalidating the Contract, order changes in the Work within the general scope of the Contract consisting of additions, deletions, or other revisions, the Contract Sum and Contract Time being adjusted accordingly.

8.2.2. A Construction Change Directive shall be used in the absence of total agreement of a Change Order.

8.2.3. Upon receipt of a Construction Change Directive, the Contractor shall promptly proceed with the change in the Work involved and advise the Owner of the Contractor's agreement or disagreement with the method, if any, provided in the Construction Change Directive for determining the proposed adjustment in the Contract Sum or Contract Time.

8.2.4. When the Owner and Contractor agree with adjustments in the Contract Sum and Contract Time, such agreement shall be effective immediately, and the Owner will prepare a Change Order. Change Orders may be issued for all or any part of a Construction Change Directive.

8.2.5. If the Contractor disagrees with the adjustment in the Contract Time or the Contract Sum, the Contractor may make a Claim in accordance with applicable provisions of Article 9.

9. CLAIMS AND DISPUTES.

9.1. A Claim is a demand or assertion by one of the parties seeking, as a matter of right, adjustment, or interpretation of the terms of the Contract Documents, payment of money, extension of time, or other relief with respect to the terms of the Contract Documents, provided that Owner's decision to adjust or withhold payment under Section 7.1.2 will not be considered a Claim. The responsibility to substantiate claims shall rest with the party making the Claim. Contractor will not knowingly (as "knowingly" is defined in the federal False Claims Act, 31 U.S.C. Section 3729, *et seq.*) present or cause to be presented a false or fraudulent

Claim. As a condition precedent to making a claim, Contractor must submit an affidavit sworn to before a notary public or other person authorized to administer oaths in the State of Ohio and executed by an authorized representative of Contractor, which states that:

The Claim submitted herewith complies with Section 9.1 of the Owner-Contractor Agreement, which provides that "Contractor will not knowingly present or cause to be presented a false or fraudulent Claim."

9.2. Subject to the requirements of Article 9, if Contractor wishes to make a Claim for an increase in the Contract Sum, written notice must be given before proceeding to execute the Work.

9.3. Subject to the requirements of Article 9, if Contractor wishes to make a Claim for additional time, the required written notice must include an estimate of cost and probable effect of delay on progress of the Work. In the event of continuing delay, only one Claim is necessary. If adverse weather conditions are the basis for a Claim for additional time, such claim must be documented by data substantiating that weather conditions were abnormal for the period of time and could not have been reasonably anticipated, and that weather conditions had an adverse effect on the scheduled construction.

9.3.1. The delays for which the Contractor is entitled to additional time are "Excusable Delays." The only Excusable Delays are those delays on the critical path which the Contractor establishes were: (a) caused by the Owner or those in privity of contract with the Owner, (b) physical damage to the Project over which the Contractor has no control, (c) labor disputes beyond the control of the Contractor, (d) work days lost due to weather conditions as provided under Section 4.4.1, (e) concealed or unknown conditions under Section 9.4, and (f) other unforeseeable delays beyond the control of the Contractor and its subcontractors and suppliers of any tier. The delays for which the Contractor is entitled to additional time and money are "Compensable Delays." The only Compensable Delays are those Excusable Delays which the Contractor establishes were proximately caused by an improper action or failure to act by the Owner. Owner, in its sole and reasonable discretion, shall determine whether a delay entitles Contractor to time extension or additional compensation.

9.4. If conditions are encountered at the site which are (1) subsurface or otherwise concealed physical conditions that differ materially from those indicated in the Contract Documents or (2) unknown physical conditions of an unusual nature that differ materially from those ordinarily found to exist and generally recognized as inherent in construction activities of the character provided for in the Contract Documents, then the Contractor shall give written notice to the Owner and the Design Professional, if any, promptly before conditions are disturbed and in no event later than forty-eight (48) hours after first observance of the conditions. If the conditions are materially different and cause an increase or decrease in the Contractor's cost of, or time required for, performance of any part of the Work, Owner will issue an appropriate Change Order.

9.5. Contractor must make all claims by written affidavit per Article 9 within seven (7) days after the occurrence of the event giving rise to the Claim. Proper notice of delay as required under Section 4.4.1 is a condition precedent to entitlement of a Claim. Failure to do so results in an irrevocable waiver of the Claim.

9.6. Within ten (10) days of its receipt of a written request, Contractor must make available to Owner or its representative any books, records, or other documents in its possession or to which it has access relating to any Claim and must require its Subcontractors, regardless of tier, and materialmen to do likewise.

9.7. If a Contractor's Claim has not been resolved at the time of Substantial Completion, the Contractor's exclusive remedy is to file suit in the Common Pleas Court for the county in which the Project is located within 90 days of Substantial Completion, unless the parties otherwise agree in writing, else such Claim is waived. Each party waives its right to remove any such suit to federal court.

9.8. Unless otherwise agreed in writing, Contractor shall continue its Work on the Project and shall maintain progress during any mediation, arbitration, or litigation proceedings, and the Owner shall continue to make payments to the Contractor in accordance with this Agreement, however, the Owner shall be under no obligation to make payments on or against any claim or amounts in dispute during the pendency of any mediation, arbitration, or litigation proceeding to resolve those claims or amounts in dispute.

9.9. Settlement Offers. If the Contractor initiates a claim, the Owner may make settlement offers to settle the Claim at any time up to the date of trial. Such settlement offers shall be subject to Rule 408 (Compromise and Offers of Compromise) of the Ohio Rules of Evidence. If at any stage of the litigation, including any appeals, the Contractor's Claim is dismissed or found to be without merit, or if the damages awarded to the Contractor on its Claim do not exceed the Owner's last settlement offer, the Contractor shall be liable to the Owner and

shall reimburse the Owner for all the Owner's attorneys' fees and expenses, and arising out of or related to such Claim since the date of such last settlement offer.

9.10. Waiver of Claims for Consequential Damages. The Contractor waives Claims against the Owner for consequential damages arising out of or relating to this Contract. This waiver includes damages incurred by the Contractor for principal office expenses including the compensation of personnel stationed there, for losses of financing, business and reputation, and for loss of profit except anticipated profit arising directly from the Work. This waiver is applicable, without limitation, to all consequential damages due to the Owner's termination of the Agreement in accordance with this Agreement.

10. DEFAULT OF CONTRACTOR.

10.1. Events of Default. Each of the following constitutes an event of default of Contractor:

10.1.1. Contractor's failure to perform any of its obligations under the Contract Documents or failure to proceed to commence to correct such failure in accordance with Section 5.1.

10.1.2. Contractor's failure to pay its obligations incurred in connection with this Agreement as they become due or Contractor's insolvency.

10.2. Owner's Remedies. Upon the occurrence of an event of default, Owner has the following remedies, which are cumulative:

10.2.1. Order Contractor to stop the Work, which Contractor must do immediately;

10.2.2. To perform through others all or any part of the Work remaining to be done and to deduct the cost thereof from the unpaid balance of the Contract Sum or, if the unpaid balance of the Contract Sum is inadequate, to demand reimbursement of amounts previously paid to Contractor;

10.2.3. To terminate this Agreement and take possession of, for the purpose of completing the Work or any part of it, all materials, equipment, scaffolds, tools, appliances, and other items belonging to or possessed by Contractor, all of which Contractor hereby transfers and assigns to Owner for such purpose, and to employ any person or persons to complete the Work, including Contractor's employees, and Contractor will not be entitled to receive any further payment until the Work is completed;

10.2.4. To accept assignment of Contractor's subcontracts for the Project, pursuant to any prior rights of the surety, if any, and, at the Owners' sole discretion, to further assign the subcontracts to a successor contractor or other entity provided that (i) the Owner terminates this Agreement for cause, and (ii) provides written notice of such assignment to both Contractor and Subcontractor; and/or,

10.2.5. All other remedies that Owner may have at law or in equity or otherwise under the Contract Documents.

10.3. Termination of Agreement. The termination of this Agreement will be without prejudice to Owner's rights and remedies, including without limitation Owner's right to be indemnified by Contractor.

10.4. Payments Due Contractor. If the unpaid balance of the Contract Sum exceeds the cost of finishing the Project, including any costs, expenses, or damages incurred by Owner as a result of the event of default, including attorneys' and consultants' fees and the administrative expense of Owner's staff, such excess shall be paid to Contractor. If such costs exceed the unpaid balance, Contractor is responsible to pay the difference to Owner. The obligations under this section will survive termination of this Agreement.

11. DEFAULT OF OWNER.

11.1.1. Events of Default. The following constitutes the exclusive events of default of Owner:

11.1.1.1. Failure of Owner to perform any express material obligation under the Contract Documents and to correct such failure within thirty (30) days after receipt of written notice thereof from Contractor specifying the default and the necessary corrective action.

11.2. Contractor's Remedy.

11.2.1. Contractor's sole and exclusive remedy for the default of Owner shall be to follow the procedure set forth in Article 9.

11.2.2. Notwithstanding Section 11.2.1, if Owner fails to pay Contractor undisputed amounts as payment becomes due, Contractor may, upon fifteen (15) days written notice, stop the Work until payment of the undisputed amount owing has been received.

12. SUSPENSION OR TERMINATION FOR THE CONVENIENCE OF OWNER.

12.1. Suspension for the Convenience of Owner.

12.1.1. Owner may, without cause, order Contractor to suspend, delay, or interrupt the Work in whole or in part for such period of time as Owner may determine.

12.1.2. An equitable adjustment will be made for increases in the Contract Time and cost of performance of the Work, including profit and overhead on the increased cost of performance, caused by the suspension, delay or interruption, provided that the total cost of profit and overhead shall not exceed ten percent (10%) of the amount of the increased cost not attributable to profit or overhead. No adjustment will be made to the extent that:

- (a) performance is, was or would have been so suspended, delayed, or interrupted by another cause for which Contractor is responsible; or
- (b) an equitable adjustment is made or denied under another provision of this Agreement for a concurrent event.

12.2. Termination for the Convenience of Owner.

12.2.1. Owner may, in its discretion and without cause, upon three (3) business days' written notice to Contractor terminate this Agreement for Owner's convenience.

12.2.2. Upon receipt of a written notice from Owner terminating this Agreement for the Owner's convenience and without cause, the Contractor will (i) immediately cease performing any or all portions of the Work, unless otherwise directed by the Owner, in which case the Contractor will take the action directed by the Owner, (ii) immediately take all reasonable and necessary action to protect and preserve the Work, and (iii) unless otherwise directed by Owner, terminate or assign all agreements with Subcontractors and suppliers.

12.2.3. If this Agreement is terminated for the Owner's convenience and there exists no event of Contractor's default, as defined in this Agreement, the Contractor shall be entitled to receive payment (i) for Work properly executed up to the date the notice of termination is received by Contractor, including overhead and profit up to the date of termination, and (ii) for Work performed at the direction of the Owner on and after the date on which the notice of termination is received by the Contractor, as determined by the procedures applicable to Change Orders.

12.2.4. If this Agreement is terminated for the Owner's convenience and there exists an event of Contractor's default, as defined in this Agreement, Contractor will be entitled to receive only such sums as it would be entitled to receive following the occurrence of an event of default under this Agreement.

12.2.5. The termination of this Agreement will be without prejudice to any rights or remedies that exist at the time of termination.

13. INSURANCE, INDEMNIFICATION, AND BOND.

13.1. Contractor must maintain commercial general liability insurance in the minimum amount of \$1,000,000.00 per incident and \$2,000,000.00 aggregate, worker's compensation coverage as required by the Ohio Revised Code, automobile liability coverage in the minimum amount of \$1,000,000.00 per accident and \$2,000,000.00 aggregate, and an umbrella policy in the minimum amount of \$5,000,000.00, unless Owner approves other coverage limits in writing. Excess or umbrella coverage may be used to meet these levels of insurance. The Owner and Design Professional, shall be named as an additional insured on the Contractor's insurance policies. The Contractor shall provide a certificate of insurance showing the required coverages, with the Owner named as a certificate holder and as an additional insured; Contractor also agrees to provide Owner with at

least thirty (30) days' notice prior to any changes in coverage of the required insurance. The Contractor shall maintain all such coverage for a period of 3 years after the Date for Final Completion.

13.1.1. The Contractor shall maintain Contractors Errors & Omissions Liability Insurance insuring against errors and omissions arising from the Work if the Work involves any construction management or the preparation of plans and drawings, with limits of not less than \$1,000,000.00 per claim. Such policy shall not contain any exclusions directed toward any types of materials, services or processes involved in the Work. The retroactive date for coverage will be no later than the commencement date of design and will state that in the event of cancellation or nonrenewal the discovery period for insurance claims will be at least three (3) years or otherwise as by written agreement with the Owner.

13.2. Insurance furnished by the Owner, if any, is not intended to and does not cover equipment and materials before they are physically incorporated into the Work or tools. Contractor bears the entire risk of loss with respect to tools, equipment, and materials. Contractor is responsible for damages to Owner's property and to adjacent property caused by or related to the Work or actions by Contractor's employees or those of its subcontractors.

13.3. The Contractor shall purchase and maintain, in a company or companies lawfully authorized to do business in the jurisdiction in which the Project is located, property insurance on an "all-risk" or equivalent policy form, including builder's risk, in the amount of the initial Contract Sum, plus the value of subsequent modifications and cost of materials supplied and installed by others, comprising total value for the entire Project at the site on a replacement cost basis without optional deductibles. Such property insurance shall be maintained, unless otherwise provided in the Contract Documents or otherwise agreed in writing by all persons and entities who are beneficiaries of such insurance, until final payment has been made as provided in Section 7.3 or until no person or entity other than the Owner has an insurable interest in the property required by this Section 13.3 to be covered, whichever is later. The insurance shall include interests of the Owner, the Contractor, Subcontractors, and Sub-subcontractors in the Project.

13.4. Owner and Contractor waive all rights, including all rights of subrogation, against each other and against Subcontractors, Sub-subcontractors, consultants, agents, and employees of the other for damages during construction, but only to the extent covered by (and not prohibited by) any applicable property insurance or builder's risk insurance, except such rights as they may have to the proceeds of such insurances.

13.5. To the maximum extent permitted by law, Contractor shall indemnify and hold harmless Owner and Owner's consultants, agents, and employees from and against all claims, damages, losses, and expenses, including but not limited to attorneys' and consultants' fees, arising out of or related to the performance of the Work, including but not limited to the failure of Contractor to perform its obligations under the Contract Documents, any claims for bodily injury, sickness, disease, or death or to injury to or destruction of or loss of use of real or personal property, claims for additional storage and handling charges, liens against funds, claims related to the alleged failure of the Contractor to perform in accordance with the Contract Documents, and/or claims related to the removal, handling, or use of any hazardous materials. Owner may withhold amounts equal to any sums for which it is entitled to be indemnified from the amounts otherwise due Contractor under the Contract Documents.

13.6. In claims against any person or entity indemnified under this Contract by an employee of Contractor, a Subcontractor, anyone directly or indirectly employed by them or anyone for whose acts they may be liable, the indemnification obligations under this Contract shall not be limited by a limitation on amount or type of damages, compensation, or benefits payable for Contractor or Subcontractor under workers' compensation acts, disability benefits acts, or other employee benefits acts. Contractor expressly waives any protection or immunity with respect to Workers' Compensation claims related to indemnification given under this Agreement.

13.7. Contract Bond [Not Used.]

13.7.1. [Not Used.]

13.7.1.1. [Not Used.]

13.7.2. [Not Used.]

13.7.3. [Not Used.]

14. WARRANTIES. In addition to any other warranties, guarantees, or obligations set forth in the Contract Documents or applicable as a matter of law and not in limitation of the terms of the Contract Documents, Contractor warrants and guarantees that:

- (a) Owner will have good title to the Work and all materials and equipment incorporated into the Work will be new;
- (b) The Work and all materials and equipment incorporated into the Work will be free from all defects, including any defects in workmanship or materials;
- (c) The Work and all equipment incorporated into the Work will be fit for the purpose for which intended;
- (d) The Work and all materials and equipment incorporated into the Work will be merchantable; and,
- (e) The Work and all materials and equipment incorporated into the Work will conform in all respects to the Contract Documents.

Upon notice of the breach of any of the foregoing warranties or guarantees or any other warranties or guarantees under the Contract Documents, Contractor, in addition to any other requirements in the Contract Documents, shall commence to correct such breach and all resulting damage within two (2) business days after written notice from the Owner. Contractor shall correct such breach and damage to the satisfaction of Owner within fifteen (15) days of such notice except when an extension of time is granted in writing by Owner; provided that if such notice is given after final payment hereunder, such 2-day period will be extended to seven (7) days and such 15-day period shall be extended to thirty (30) days. If Contractor fails to commence to correct such breach and damage, or to correct such breach and damage as provided above, Owner, upon written notice to Contractor and without prejudice to any of its other rights or remedies, may correct the deficiencies. Contractor upon written notice from Owner shall pay Owner, within ten (10) days after the date of such notice, all of Owner's costs and expenses incurred in connection with or related to such correction and/or breach, including without limitation Owner's administrative, legal, design, and consulting expenses. The foregoing warranties and obligations of Contractor will survive the final payment and/or termination of this Agreement. If the Contractor fails to pay the Owner any amounts due under this Article 14, Contractor will pay Owner, in addition to the amounts due, a late payment fee of one and one-half percent (1.5%) per month for each month or part thereof that the payments are not paid when due.

15. GENERAL.

15.1. Modification. No modification or waiver of any of the terms of this Agreement or of any other Contract Documents shall be effective against a party unless set forth in writing and signed by or on behalf of a party, which in the case of Owner shall require the signature of Owner pursuant to a specific resolution of Owner. Under no circumstances will forbearance, including the failure or repeated failure to insist upon compliance with the terms of the Contract Documents, constitute the waiver or modification of any such terms. The parties acknowledge that no person has authority to modify this Agreement or the other Contract Documents or to waive any of its or their terms, except as expressly provided in this Paragraph.

15.2. Assignment. Contractor may not assign this Agreement without the written consent of Owner, which Owner may withhold in its sole discretion.

15.3. Third Parties. Nothing contained in this Agreement shall create a contractual relationship with or a cause of action in favor of a third party against either Owner or Contractor.

15.4. Law and Jurisdiction. All questions regarding the validity, intention, or meaning of this Agreement or any modifications of it relating to the rights and obligations of the parties shall be construed and resolved under the laws of the State of Ohio. Any suit, which may be brought to enforce any provision of this Agreement or any remedy with respect hereto, shall be brought in the Common Pleas Court for the county in which the Project is located, and each party hereby expressly consents to the jurisdiction of such court. Each party waives its right to remove any such suit to federal court.

15.5. Statute of Limitations. Regardless of any provision to the contrary, the statute of limitations with respect to any defective or non-conforming Work that is not discovered by Owner will not commence until the discovery of such defective or non-conforming Work by Owner.

15.6. Notices. Notices, requests, or demands by either party shall be in writing, unless otherwise expressly authorized, and shall be personally served; forwarded by expedited messenger service; sent by facsimile transmission; sent by electronic mail with delivery confirmation; or be given by registered or certified mail, return receipt requested, postage prepaid, and addressed to the party at the address set forth at the beginning of this Agreement. Any party may change its address by giving written notice hereunder. All notices, requests, and demands shall be deemed received upon receipt in the case of personal delivery or delivery by expedited messenger service, including leaving the notice at the address provided herein during normal business hours; upon the expiration of forty-eight (48) hours from the time of deposit in the United States mail; or, in the case of a notice given by electronic mail or facsimile transmission, upon the expiration of 24 hours after the transmission is sent.

15.7. Construction. The parties acknowledge that each party has reviewed this Agreement and the other Contract Documents and has voluntarily entered into this Agreement. Accordingly, the normal rule of construction to the effect that any ambiguities are to be resolved against the drafting party shall not be employed in the interpretation of this Agreement, the other Contract Documents, or any amendments or exhibits to it or them.

15.8. Approvals. Except as expressly provided herein, the approvals and determinations of Owner will be subject to the sole discretion of Owner and will be valid and binding on Contractor, provided only that they be made in good faith, *i.e.*, honestly. If Contractor challenges any such approval or determination, Contractor bears the burden of proving by clear and convincing evidence that it was not made in good faith.

15.9. Partial Invalidity. If any term or provision of this Agreement is found to be illegal, unenforceable, or in violation of any laws, statutes, ordinances, or regulations of any public authority having jurisdiction, then, notwithstanding such term or provision, this Agreement shall remain in full force and effect, and such term shall be deemed stricken; provided this Agreement shall be interpreted, when possible, so as to reflect the intentions of the parties as indicated by any such stricken term or provision.

15.10. Compliance with Laws and Regulations. Contractor, at its expense, must comply with all applicable federal, state, and local laws, rules, and regulations applicable to the Work, including but not limited to ORC Chapter 4115 regarding prevailing wage rates, if applicable.

15.11. Project Safety. Contractor must follow all applicable safety and health regulations during the progress of the Project and monitor all of its employees and its subcontractors for compliance with such safety and health regulations. In undertaking the responsibilities set forth in this section, Contractor does not assume any duty or responsibility to the employees of any Subcontractor or supplier, regardless of tier. Owner assumes no responsibility for the development, review, or implementation of any project safety plan or for Project safety and has no authority to direct the means and methods of Contractor.

15.12. Equal Opportunity. Contractor will not, and it will ensure that its Subcontractors, regardless of tier, do not, discriminate against any employee or applicant for employment because of race, religion, color, sex, or national origin. Such action includes but is not limited to the following: employment, upgrading, demotion, transfer, recruitment or recruiting advertising, layoff or termination, rates of pay or other forms of compensation, and selection for training, including apprenticeship. Contractor agrees to post in conspicuous places, available to employees and applicants for employment, notices setting forth the policies of nondiscrimination. Contractor is responsible to ensure that each of its Subcontractors, regardless of tier, states in all solicitations or advertisements for employees placed by them or on their behalf that all qualified applicants will receive consideration for employment without regard to race, religion, color, sex, or national origin.

15.13. No Findings for Recovery. The Contractor represents that the Contractor is not subject to a finding for recovery under Section 9.24, Ohio Revised Code, or that the Contractor has taken the appropriate remedial steps required under Section 9.24, Ohio Revised Code, or otherwise qualifies under this section. If this representation and warranty is found to be false, the Contract is void, and Contractor will immediately repay Owner any funds paid to Contractor under this Contract.

15.14. Non-Discrimination. Contractor agrees:

- (a) Per Section 153.59 of the Ohio Revised Code in the hiring of employees for the performance of Work under this Agreement or in any subcontract, neither the Contractor, subcontractor, nor any person acting on behalf of either of them, shall by reason of race, creed, sex, disability, military status as defined in Section 4112.01 of the Revised Code, or color, discriminate against any citizen of the

state in the employment of labor or workers who are qualified and available to perform the Work to which the employment relates.

(b) That neither the Contractor, subcontractor, nor any person acting on behalf of either of them, shall, in any manner, discriminate against or intimidate any employee hired for the performance of Work under this Agreement on account of race, creed, sex, disability, military status as defined in Section 4112.01 of the Revised Code, or color.

(c) That there shall be deducted from the amount payable to the Contractor by the Owner under this Agreement a forfeiture of twenty-five dollars (\$25.00) as required by Ohio Revised Code Section 153.60 for each person who is discriminated against or intimidated in violation of this Agreement.

(d) That this Agreement may be canceled or terminated by the Owner and all money to become due hereunder may be forfeited for a second or subsequent violation of the terms of this section of this Agreement.

15.15. Use of Owner's Facilities. Contractor will ensure that neither its employees, nor its Subcontractor's or material supplier's employees, regardless of tier, do any of the following without the express prior written consent of Owner:

- (a) use Owner's facilities including but not limited to, common areas, rest rooms, or phones;
- (b) use or bring any alcoholic beverages, controlled substances, or firearms on any property owned by Owner;
- (c) use any radios, tape or compact disc players, or sound amplification equipment; and
- (d) interact in any manner with building occupants, except where necessary to preserve the safety of building occupants.

Contractor must conspicuously post notice of the prohibitions listed in this section at the Project site in the same location as OSHA notices are required to be posted and shall verbally inform all of Contractor's employees, and the employees of Contractor's Subcontractors and materialmen, regardless of tier, of such prohibitions. The notice must be in a form acceptable to Owner.

15.16. Entire Agreement. This Agreement and the other Contract Documents constitute the entire agreement among the parties with respect to their subject matter and will supersede all prior and contemporaneous, oral or written, agreements, negotiations, communications, representations, and understandings with respect to such subject matter, and no person is justified in relying on such agreements, negotiations, communications, representations, or understandings.

15.17. Attachments. Attachments to this Agreement include:

Exhibit A: [Not Used.]

Exhibit B: Sales & Use Tax/ Construction Contract Exemption Certificate

Exhibit C: Contractor's Proposal, dated _____, as modified, to the extent not inconsistent with the terms of this Agreement.

However, in the event of an inconsistency, the provisions of this Agreement control over any proposal, document, or other attachment.

IN WITNESS WHEREOF, the parties have caused this Agreement to be executed by their properly authorized representatives.

Owner:
Gallipolis City School District Board of Education

Contractor:

Signature

Signature

By: _____
Printed Name and Title

By: _____
Printed Name and Title

Date: _____

Date: _____

CERTIFICATE OF FUNDS
(ORC Section 5705.41)

The undersigned, Fiscal Officer of the Owner, hereby certifies in connection with the Agreement to which this Certificate is attached that the amount required to meet the obligations under the contract, obligation, or expenditure for the services described in the attached agreement, has been lawfully appropriated for the purpose, and is in the treasury or in process of collection to the credit of an appropriate fund, free from any outstanding obligation or encumbrance.

Dated: _____

Fiscal Officer

Exhibit B

Sales & Use Tax / Construction Contract Exemption Certificate



Sales and Use Tax Construction Contract Exemption Certificate

Identification of Contract:

Contractee's (owner's) name _____

Exact location of job/project _____

Name of job/project as it appears
on contract documentation _____

The undersigned hereby certifies that the tangible personal property purchased under this exemption certificate is purchased exempt of the tax for incorporation into:

A building used exclusively for charitable purposes by a nonprofit organization operated exclusively for charitable purposes as defined in Ohio Revised Code (R.C.) section 5739.02(B)(12);	Real property that is owned, or will be accepted for ownership at the time of completion, by the United States government, its agencies, the state of Ohio or an Ohio political subdivision;
A horticulture structure or livestock structure for a person engaged in the business of horticulture or producing livestock;	Real property under a construction contract with the United States government, its agencies, the state of Ohio, or an Ohio political subdivision;
The original construction of a sports facility under R.C. section 307.696;	A building under a construction contract with an organization exempt from taxation under section 501(c)(3) of the Internal Revenue Code of 1986 when the building is to be used exclusively for the organization's exempt purposes;
A hospital facility entitled to exemption under R.C. section 140.08;	
A computer data center entitled to exemption under R.C. 122.175; ___% exempt per OH Dept. of Development	A house of public worship or religious education;
A megaproject entitled to exemption as described in R.C. 5739.02(B)(13).	Building and construction materials and services sold for incorporation into real property comprising a convention center that qualifies for property tax exemption under R.C. 5709.084 (until one calendar year after the construction is completed).
Real property outside this state if such materials and services, when sold to a construction contractor in the state in which the real property is located for incorporation into real property in that state, would be exempt from a tax on sales levied by that state;	

The original of this certificate must be signed by the owner/contractee and/or government official and must be retained by the prime contractor. Copies must be maintained by the owner/contractee and all subcontractors. When copies are issued to suppliers when purchasing materials, each copy must be signed by the contractor or subcontractor making the purchase.

Prime Contractor

Name _____
Signed by _____
Title _____
Street address _____
City, state, ZIP code _____
Date _____

Owner/Contractee

Name _____
Signed by _____
Title _____
Street address _____
City, state, ZIP code _____
Date _____

Subcontractor

Name _____
Signed by _____
Title _____
Street address _____
City, state, ZIP code _____
Date _____

Political Subdivision

Name _____
Signed by _____
Title _____
Street address _____
City, state, ZIP code _____
Date _____

Exhibit C

Contractor's Proposal, as
modified, to the extent not
inconsistent with the terms of
this Agreement