

SECTION 26 05 00

COMMON WORK RESULTS FOR ELECTRICAL

PART 1 – GENERAL

A. SUBJECT TO CHANGE

1. These standards are subject to change. Verify that the latest are being used. Product manufacturers listed is the basis of design or equivalent unless noted otherwise.

B. SUMMARY – SECTION INCLUDES

1. Common Work Results for Electrical Systems

C. SUBMITTAL

1. The following products require submittal
 - a. Conduit and fitting
 - b. Surface raceway
 - c. Pull and junction box
 - d. Conductor and connector
 - e. Fuse
 - f. Access panel
 - g. Equipment identification
 - h. Circuit identification
 - i. Remote marquee
 - j. Ground testing
 - k. Compression fitting
 - l. Remote marquee
 - m. Power system study and associated warning sign
 - n. Electronic power monitor
 - o. Phase monitoring
 - p. Electrical service entrance
 - q. Switchboard
 - r. Panelboard
 - s. Dry type transformer
 - t. Engine generator
 - u. Automatic transfer switch
 - v. Receptacle
 - w. Switch
 - x. Dimmer
 - y. Device plate
 - z. Weatherproof enclosure
 - aa. Standalone occupancy and vacancy sensor
 - bb. Lighting control
 - cc. Perimeter raceway
 - dd. Recessed floor box for slab on grade
 - ee. Flush poke-through assembly
 - ff. Service pole
 - gg. Cord Reel
 - hh. Cord Drop
 - ii. Enclosed switch
 - jj. Elevator disconnect
 - kk. Manual motor starter
 - ll. Luminaire

- mm. Sound system
- nn. Fire detection and alarm

D. OPERATION AND MAINTENANCE MANUALS

- 1. Include the following
 - a. All product documentation
 - b. All test reports
 - c. Letter of warranty
 - d. Record drawings
 - e. Transmittal of extra material
- 2. Requirements of operation and maintenance manuals
 - a. Review PDF
 - b. 3 final hard copies and one thumb drive

E. RECORD DRAWINGS

- 1. Requirements of record drawings
 - a. Keep on site during installation, include addenda, RFI's, change orders, products supplied, updated panelboard schedules (including loads), feeder conduit routing, pull/junction boxes larger than 18 by 18 inch, site underground conduits (lighting, feeders, empty conduits, and service conduits, etc.)
 - b. Submit to design team in hard copy or PDF

F. EXTRA MATERIAL

- 1. Requirements of extra material
 - a. Stored in original boxes (refer to individual products for quantities)
 - b. Transmittal with list of material to CCSD to be left at the associated building

G. METHOD OF PROCEDURE

- 1. Requirements for power interruption
 - a. Submit method of procedure for power outages
 - b. Scheduling of power outage one (1) month prior to proposed outage
 - c. Detailed method of procedure reviewed and approved two (2) weeks prior to outage

H. FEES AND PERMITS

- 1. Contractor responsible for fees, including utility, and permits

I. TEMPORARY LIGHTING AND POWER

- 1. Requirements for temporary lighting and power
 - a. Temporary lighting required to meet OSHA requirements when permanent lighting is not available
 - b. 20 ampere, 120 volt GFCI receptacle per 1500 square foot area
 - c. Power to construction equipment
 - d. Temporary fire alarm devices until replacement system is functional

J. DEMOLITION

- 1. Requirements for demolition
 - a. CCSD has the first right of refusal on removed items, if CCSD does not pick-up the items within 5 business days, then the items to be disposed of properly
 - b. Completely remove electrical components associated with remove equipment, unless reused for new installation

- c. Regardless of why a ceiling has been removed anywhere in a building, the cables are to be supported and electrical boxes/conduits not properly supported or closed are to be corrected
 - d. Disposed of properly and pay associated fees for hazardous material
- K. REUSE OF EXISTING EQUIPMENT
 - 1. Requirements for reused of existing equipment
 - a. Maintain UL Listing
 - b. Clean and repair luminaires
 - c. Replace lamps and ballasts
 - d. Update panelboard directories
- L. FLOOR PENETRATION
 - 1. Requirements for floor penetration
 - a. On grade, seal with grouted air tight
 - b. Above grade, install sleeves with grouted or fire stop seal air tight
- M. PENETRATION
 - 1. Maintain fire rating
- N. HOUSEKEEPING PAD
 - 1. Requirements for housekeeping pad
 - a. For floor/ground mounted pad mounted transformers, switchboards, distribution panels, generators, and dry type transformers
 - b. 4 inches high, minimum
 - c. 2 inches beyond equipment supported, minimum
 - d. Equipment bolted to pad
- O. CONTROL SYSTEM
 - 1. Dedicated 20 ampere, 120 volt circuit per control panel connected with surge protective duplex receptacle
- P. PAINTING
 - 1. Touch up electrical equipment with matching paint to factory standard
- Q. EQUIPMENT PROVIDED BY OTHERS
 - 1. Coordinate and adjust as required for equipment provided by others
- R. WARRANTY
 - 1. Overall electrical installation to have a one (1) year warranty, refer to specific products with a longer warranty period
- S. COMPLETION
 - 1. Requirements for completion
 - a. Load balance to 10 percent between phases with updates to record drawings, junction box labels, device circuit labeling, etc.
 - b. Install equipment labels
- T. TESTING
 - 1. Requirements for testing
 - a. Self
 - b. Equipment manufacturer

- c. Third party – Vertiv or RESA Power
- d. Visual review (self)
- e. Torque (self)
- f. Cleanliness of equipment (self)
- g. Megger test feeders (self)
- h. Test and adjust dry type transformer taps (self)
- i. Noise level of dry type transformers (self)
- j. Ground fault interruption testing (third party)
- k. Electronic trip circuit breakers (third party)
- l. Ground resistance (third party)
- m. Reports of testing (submitted and in operation and maintenance manuals)
- n. Refer to other items for individual testing

U. COMMISSIONING

- 1. Requirements for commissioning
 - a. Witnessed and reported to CCSD
 - b. Lighting control systems
 - c. Fire alarm system
 - d. Generator/ATS
 - e. Sound systems
 - f. Educational intercommunication system
 - g. Kiln control
 - h. Kitchen hood/equipment control

V. MOUNTING HEIGHTS (adjust per location)

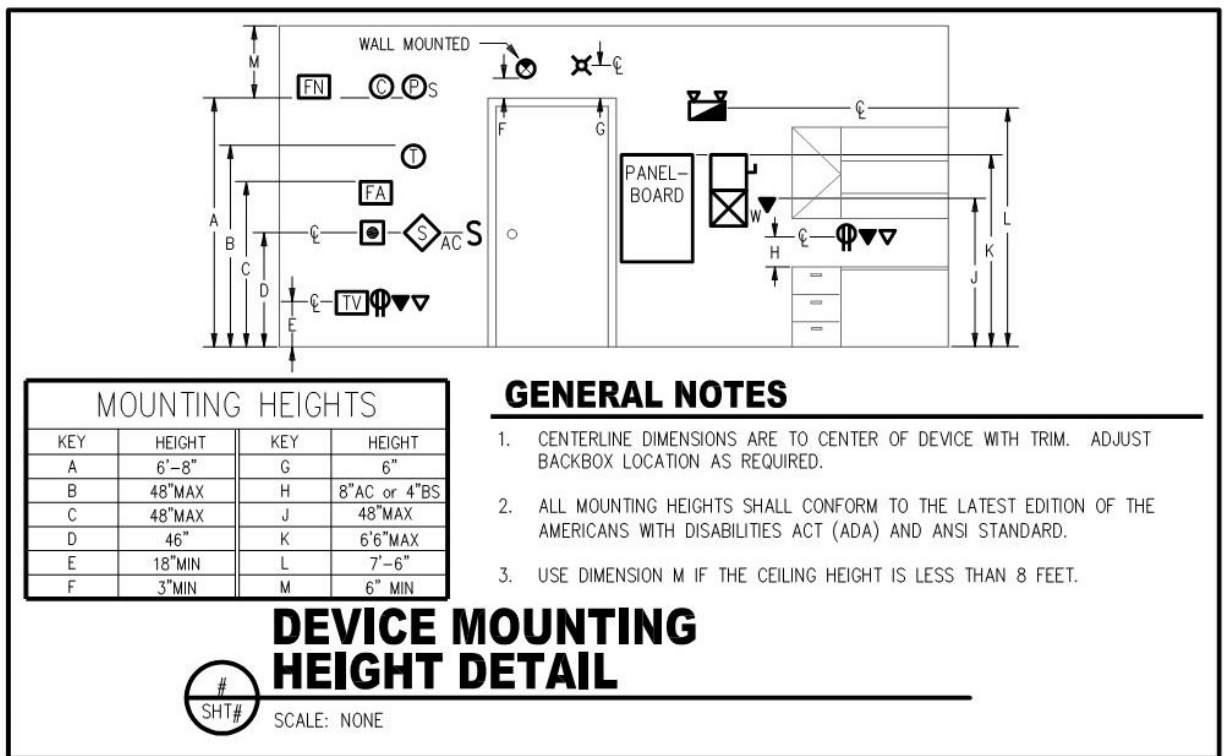

W. KILN CONTROL (adjust per location)

1. Kiln Control (coordinate interface with building automation system designer/installer, electrical contractor, and fire alarm design/installer, plus adjust based on kilns provided and verify with CCSD). Select which detail applies to the application.

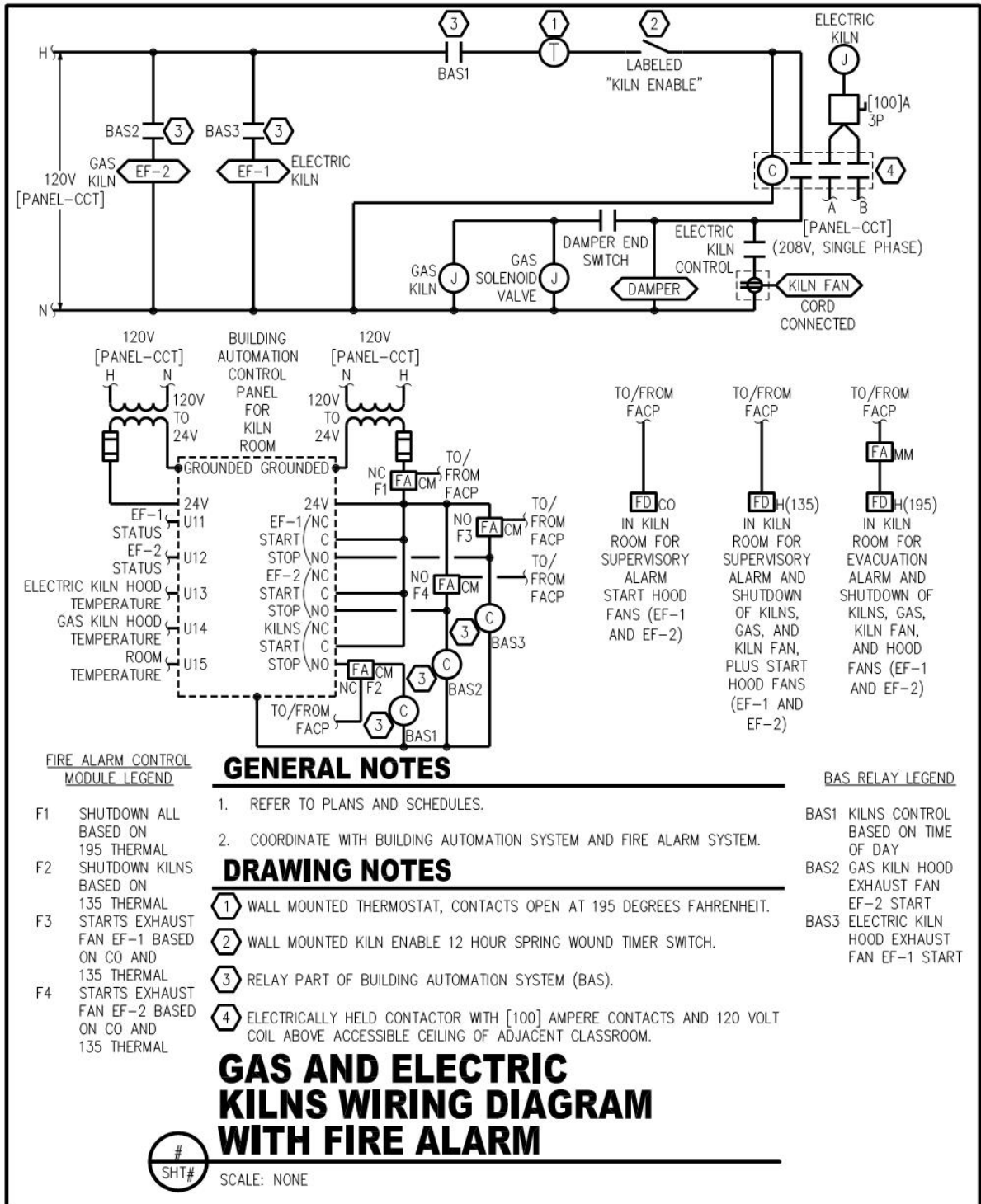

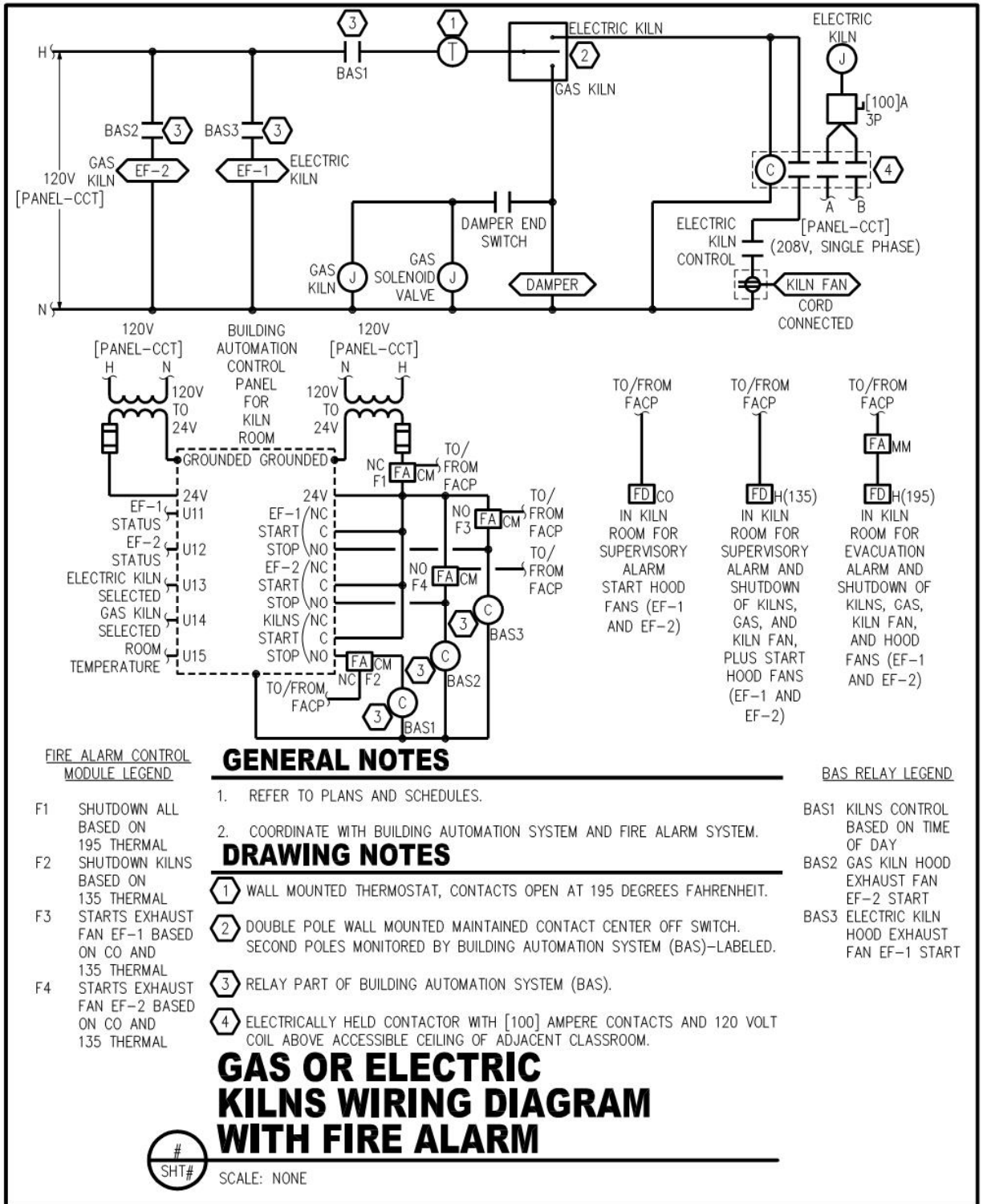

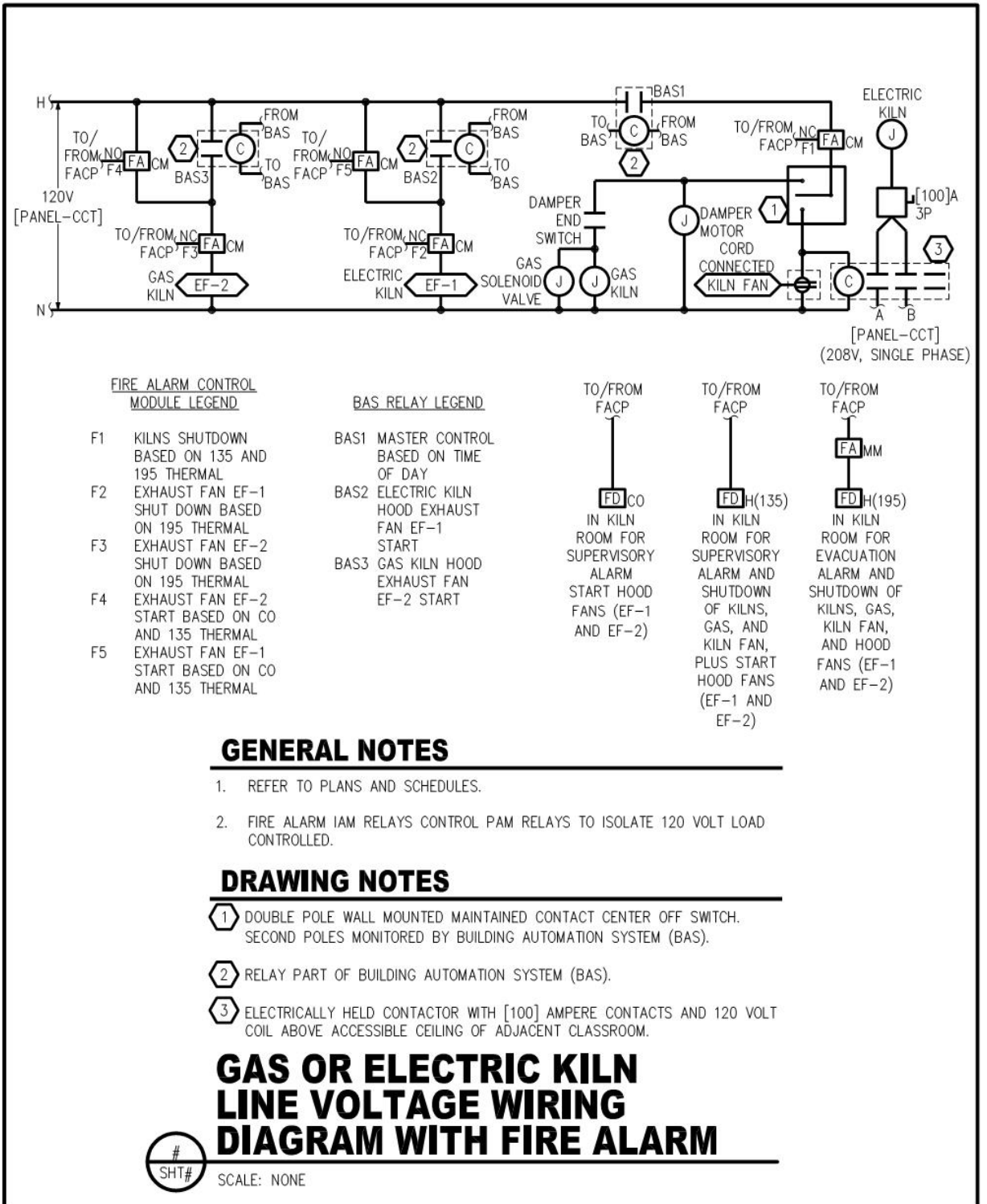

X. KITCHEN HOOD CONTROL PANEL (adjust per location)

1. Kitchen Hood Control (coordinate interface with kitchen equipment, building automation system designer/installer, electrical contractor, mechanical contractor, and fire alarm design/installer, plus adjust based on hood, kitchen equipment, and mechanical equipment provided, and verify with CCSD).

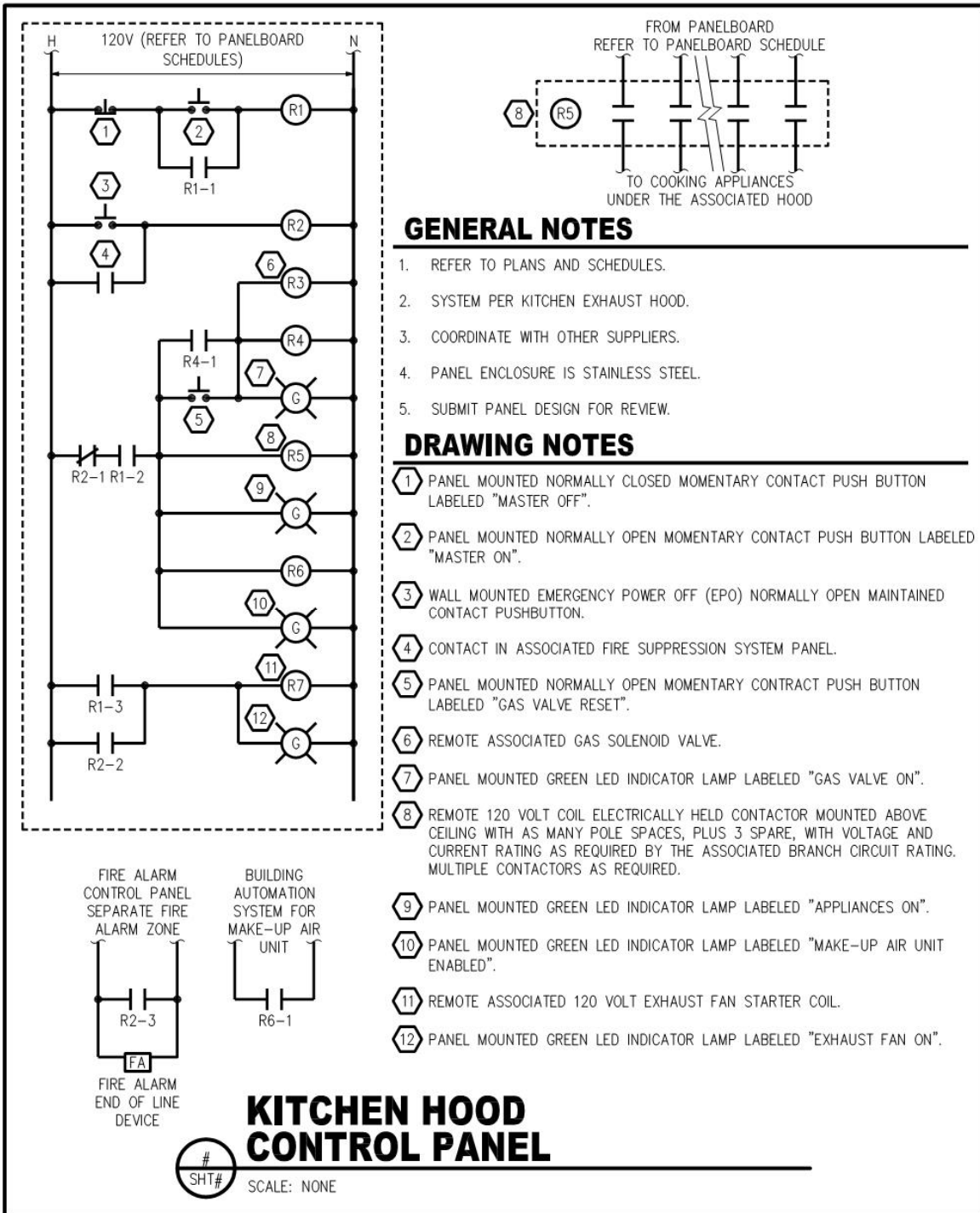

Y. REMOTE MARQUEE

1. Requirements for remote marquee
 - a. Submittal
 - b. Constructed on concrete footing or piers designed by structural engineer for the site wind loading
 - c. Exterior structure material match building block or brick
 - d. Graphic display cabinet to be energy efficient replaceable modular LED boards with a 192 by 64 pixel resolution, or as required by distance from the roadway, IP65 front, IP55 back, IP67 modules, temperature range of -40 to 158 degrees Fahrenheit, automatic dimming between sunset and sunrise, wirelessly controlled with internal memory for up to 100 messages during a 10 hour power outage, and password protected software compatible with workstation located inside building
 - e. Lockable electrical disconnect
 - f. Maximum 20 ampere, 120 volt service for elementary and middle school buildings
 - g. Maximum 30 ampere, 120 volt service for high school buildings
 - h. Wire sized for maximum of 3 percent voltage drop
 - i. Installed under the supervision of a general contractor licensed in Colorado
 - j. Manufacturer-employed technician or factory trained installer present during at least display installation
 - k. Inspect areas in areas of work
 - l. Repair all disturbed areas to original condition
 - m. Clean up, maintain safety, not interfere with the typical building occupant access to the associated building, and remove waste each work day
 - n. All federal, state, and local standards and codes regarding safety must be adhered to and met
 - o. Prior to ordering material or starting the project verify installation, submit discrepancies in writing for consideration
 - p. Comply with manufacturer's recommendations, procedures, and standards for assembly and operation of the systems, includes all equipment, hardware, materials, and methods
 - q. Demonstrate acceptable system performance upon completion of the work and instruct CCSD on the programming and operation for a minimum of 2 hours

END OF SECTION

PAGE INTENTIONALLY BLANK

SECTION 26 05 10

BASIC ELECTRICAL MATERIALS

PART 1 – GENERAL

A. SUBJECT TO CHANGE

1. These standards are subject to change. Verify that the latest are being used. Product manufacturers listed is the basis of design or equivalent unless noted otherwise.

B. SUMMARY – SECTION INCLUDES

1. Basic Electrical Materials

C. CONDUIT

1. General requirements for conduit
 - a. Submittal
 - b. Routed perpendicular and parallel with building lines
 - c. Concealed in finished areas (CCSD approval required for surface mounted raceways on existing concrete, masonry, or etc. surfaces, plastic raceways, Panduit type, are not unacceptable)
 - d. Conduit concealed in masonry walls, minimum of 1 inch from masonry surface
 - e. Include ground conductor (except for electrical service conduits)
 - f. Metallic conduit electrically continuous
 - g. 12 inches above ceilings
 - h. Not routed on roofs without prior approval in writing from CCSD. If approved, then 12 inches above roof on B-Line DBE supports or DB_BS channel racks with roof protection under supports
 - i. Not closer than 12 inches from heat sources
 - j. Separate raceways for systems, voltages, and normal verses generator power
 - k. Expansion joints at building expansion joints and as required to avoid contraction and expansion stresses
 - l. No conduits in floor slabs
2. Rigid Metal Conduit
 - a. Threaded fittings
 - b. 3/4 inch minimum
 - c. 1 inch minimum exterior
 - d. PVC coated sweeps or elbows for more than 30 degree offsets underground or stub-ups or runs greater than 100 feet
 - e. PVC coated minimum of 5 feet on either side of foundation or utility vault penetration
 - f. Exposed exterior and wet locations
 - g. Where subject to physical damage
 - h. Bends for runs larger than 1-1/4 inch factory made
 - i. Bends for 1 inch and 1-1/4 inch factory made or approved bending machine
 - j. Ground bushings (minimum of one end of conduit) at equipment and boxes
3. Electrical Metallic Tubing (EMT)
 - a. Steel set screw connectors
 - b. Rain tight compression type in crawl spaces less than 5 feet deep
 - c. Uninsulated connectors with insulated bushings for larger than 1 inch
 - d. 1/2 inch minimum with 3/4 inch minimum for homeruns
 - e. Majority of interior
 - f. Bends for runs larger than 1-1/4 inch factory made
 - g. Bends for 1 inch and 1-1/4 inch factory made or approved bending machine
 - h. Ground bushings (minimum of one end of conduit) at equipment and boxes

4. Flexible Metal Conduit
 - a. Steel continuous ground spiral
 - b. Steel or malleable iron designed for the purpose fittings
 - c. 1/2 inch minimum
 - d. 3/8 inch minimum for luminaire whips with 18 AWG conductors
 - e. Interior mechanical equipment (maximum of 3 feet)
 - f. Interior dry type transformers (maximum of 3 feet)
 - g. Maximum length of 6 feet or maximum of 3 feet concealed by a wall
 - h. Luminaire whips
 - i. Not for homeruns
5. Liquid Tight Flexible Metal Conduit
 - a. Steel continuous ground spiral with oil and sunlight resistant polyvinyl chloride jacket bonded or extruded onto the exterior
 - b. Steel or malleable iron designed for the purpose fittings
 - c. 3/4 inch minimum
 - d. 1 inch minimum exterior
 - e. Exterior mechanical equipment (maximum of 6 feet)
 - f. Exterior dry type transformers (maximum of 6 feet)
 - g. Generators
6. Rigid Nonmetallic Conduit
 - a. Schedule 40 PVC rated for use with 90 degree C wire
 - b. Fittings that match the conduit
 - c. 1 inch minimum
 - d. Direct buried below slab on grade or exterior
 - e. Concrete encased
 - f. Electrical service conductors concrete encased
 - g. Fittings glued
 - h. PVC coated rigid metal elbows for more than 30 degree offsets underground or stub-ups or runs greater than 100 feet
 - i. PVC coated rigid minimum of 5 feet on either side of foundation or utility vault penetration
 - j. 30 inches below grade or 12 inches below bottom of floor slab
 - k. Multiple non-concrete encased conduits to have 3 inch cover of squeegee
 - l. For exterior underground power, signal, and communication lines, install continuous underground plastic line marker tape located directly above such lines. Marker shall be permanent, bright-colored, continuous-printed, vinyl tape not less than 4 mils thick by 6 inches wide with an embedded continuous metallic strip or core. Marker printing indicates type of underground line. Locate 6 to 8 inches below finished grade, unless otherwise indicated. Where multiple lines installed in a common trench or concrete encased do not exceed an overall width of 16 inches, use a single line marker with printing indicating the multiple lines. Stub ends of tape above grade at both ends.

D. SURFACE RACEWAY

1. Requirements for surface raceway
 - a. Submittal
 - b. Metal only
 - c. For individual circuits, Wiremold 500 or 700 series with associated components
 - d. For multi-circuits, Wiremold 4000 series
 - e. Used where all other options have been exhausted on existing concrete, masonry, or etc. surfaces and with approval by CCSD

E. MC CABLE

1. Requirements for MC Cable
 - a. Submittal
 - b. Consist of color coded insulated conductors wrapped surrounded with a moisture resistant tape and enclosed in a galvanized steel interlocked cladding
 - c. Each cable shall contain a full sized ground wire
 - d. MC cable is not allowed except where specifically indicated, approved by CCSD, and only above accessible grid ceiling for 20 and 30 amperes branch circuit wiring
 - e. Not used for homeruns
 - f. Properly support
 - g. AC cables, NM cables, modular wiring not allowed

F. PULL AND JUNCTION BOX

1. Requirements for pull and junction box
 - a. Submittal
 - b. Interior, galvanized sheet metal boxes with lapped and welded joints, 3/4 inch flanges and screw covers
 - c. Exterior galvanized sheet metal lapped and welded joints, 3/4 inch flanges, bolted covers with full gaskets forming a completely raintight assembly
 - d. Exterior in graded, heavy duty (traffic rated where required) externally flanged for flush mounting with covers fully gasketed, watertight and secured with plated screws or bolts
 - e. Interior, minimum 4 inch square, 2-1/8 inches deep
 - f. Locate to maintain access
 - g. Separate boxes for different voltages and for normal verses generator systems
 - h. Interior, install for conduit runs longer than 100 feet
 - i. Painted inside and outside to identify
 - j. Label cover with associated panelboard, circuit(s), and voltage
 - k. Independently supported

G. OUTLET BOX

1. Requirements for outlet box
 - a. Submittal
 - b. Zinc or cadmium plated code gauge pressed steel and of the knock out type with depth to suit requirements of location
 - c. Accommodate devices, conduits and conductors entering and leaving
 - d. Round boxes not permitted, except where specifically indicated or to match equipment
 - e. Oversized outlet boxes galvanized steel and of the knock out type with screw mounted covers for surface or flush mounting
 - f. Sized as indicated or as required by the NEC. Special outlet boxes shall accommodate the equipment served
 - g. Weatherproof boxes cast aluminum with threaded hubs and screw mounted, gasketed covers
 - h. Interior walls, minimum 4 inch square, 2-1/8 inch deep with plaster ring
 - i. IT boxes, minimum 4 inch square, 2-1/2 inch deep with plaster ring
 - j. Ceilings, minimum 4 inch octagonal, 1-1/2 inch deep or 4-11/16 inch by 2-1/8 inch
 - k. Masonry, minimum 2-1/2 inch by 3-3/4 inch deep single gang with plaster ring if block wall will be plastered
 - l. Painted inside and outside to identify
 - m. Interior walls, vertical
 - n. Above counters, horizontal
 - o. Receptacles within 18 inches of IT outlet

H. CONDUCTOR

1. Requirements for conductor
 - a. Submittal
 - b. Aluminum conductors not allowed
 - c. Minimum number 12 AWG, 98 percent conductivity copper conductors with 600 volt continuous color insulation
 - d. Number 12 AWG and smaller wire except for motor circuits solid with type THHN, or THWN insulation, larger wire and motor circuit feeders stranded with type THHN, or THWN insulation
 - e. Conductors for service entrance use or where used underground type XHHW only
 - f. Fire alarm wire and cable meets requirements of NEC Article 760
 - g. Digital communication, network cabling, and other low voltage systems wiring compatible with system
 - h. Upsize to limit voltage drop at panelboard or distribution panel to 2 percent
 - i. Upsize to limit voltage drop at last device to 3 percent
 - j. Coordinate conductor size with equipment lugs
 - k. 8 inch slack at each outlet
 - l. Maintain separation of different classes of wiring
 - m. Replace existing aluminum conductors
 - n. Installed in conduit, except fire alarm notification circuits, educational intercommunication system, lighting control systems, and sound systems
 - o. 208Y/120V insulation colors: A (black), B (red), C (blue), Neutral (white), Ground (green), Isolated Ground (green with yellow stripe)
 - p. 480Y/277V insulation colors: A (brown), B (orange), C (yellow), Neutral (gray), Ground (green)
 - q. Fire detection and alarm system: speakers (red with green stripe), strobe (red with yellow stripe), power (red with purple stripe), and SLC (red with no stripe)
 - r. Educational intercommunication system: Green

I. CONDUCTOR CONNECTOR

1. Requirements for conductor connector
 - a. Submittal
 - b. For solid wire size number 10 and smaller, "Scotchlok" type Y, R G, or B insulated twist on spring connectors or compression type, 600 volt insulated or acceptable substitution
 - c. For stranded wire number 8 to number 4, "IlSCO" type PCT mechanical tap with clear insulator
 - d. For stranded wire number 3 and larger, "Burdny" long high press compression butt splice type, with heat or cold shrink sleeve
 - e. No Wago connectors
 - f. Installed inside of an accessible, adequately size electrical box
 - g. Motor connections larger than number 10 to be IlSCO or split bolt

J. PULLING COMPOUND

1. Requirements for pulling compound
 - a. Powdered soapstone, ideal "Aqua Gel CW" or Dow Corning compound #7 wire pulling lubricant to pull conductors
 - b. Use sparingly

K. LOW VOLTAGE ROUGH-IN SYSTEM COMPONENT

1. Requirements for low voltage rough-in system component
 - a. Components furnished by Others; system equipment, special outlet box receptacles, power unit cabinets, special outlet boxes, and cable

- b. 4 foot by 8 foot by 3/4 inch plywood backboards
- c. Four (4), four (4) inch conduit for underground service entrance conduit for telephone and CATV
- d. Cable supports; 2 inch diameter galvanized wide base J hooks
- e. Bridal rings for maximum of 8 cables
- f. Outlet boxes with conduit stubbed with 90 degree elbow, insulated throat bushing and pull cords to above nearest accessible ceiling or cable tray
- g. Telephone and CATV service conduits to the main equipment room

L. SUPPORT DEVICE

1. Requirements for support device
 - a. Corrosion resistant or galvanized steel supporting devices and hangers for electrical equipment from this list of Caddy Fasteners
 - b. "Z" purlin clips: 1-1/4 inch maximum conduit
 - c. Conduit clips: 2 inch maximum conduit
 - d. Beam clamps (rod hanger clamps and vertical flange clamps) for support of threaded rod
 - e. Beam clamps (set screw type): 2 inch maximum conduit
 - f. Beam clamps (universal) for support of boxes and combination conduit hanger clamps
 - g. Combination push in conduit clips: 1 inch maximum conduit
 - h. Combination conduit hanger clamps: 2 inch maximum conduit
 - i. Flexible conduit clips: 1 inch maximum flexible conduit
 - j. Special combination conduit clips: 1 inch maximum conduit
 - k. Two hole steel straps
 - l. Conduit hangers: 4 inch maximum conduit
 - m. Screw gun box brackets
 - n. "H" box mounting brackets
 - o. Adequately rated

M. CONDUIT SUPPORT

1. Requirements for conduit support
 - a. Single Runs: Galvanized malleable iron conduit straps for surface mounting or 1/4 inch threaded rod with steel one bolt conduit clamps for all suspended runs
 - b. Multiple Runs: Unistrut or Kindorf channel support for surface mounting or trapeze style hangers of 1-5/8 inches or 13/16 inches width (depth as required) Unistrut or Kindorf painted or galvanized steel channels, supported by 3/8 inch threaded rod for all suspended runs with hangers to allow for 25 percent additional conduits
 - c. Supports and hardware shall be galvanized steel, except that high carbon spring steel supports may be used in steel stud walls to support horizontal and vertical conduit up to 3/4 inch
 - d. Perforated plumbing tape is not permitted in any support application
 - e. Above suspended lay in ceilings, Caddy spring steel clips and dedicated red number 14 support wires may be used to support single runs of suspended electrical metallic tubing up to 3/4 inch within a single room where the structure is more than 4 feet above the level of the ceiling
 - f. Use of Caddy 812MB18A allowed only where an air duct interferes with direct support to structure
 - g. Coordinate requirements for seismic zone
 - h. Multiple conduit support rated for four (4) times the present load with a minimum 200 pounds design load
 - i. Support directly from structure
 - j. Cross bracing as required

- k. Cut ends of channels painted with rust inhibiting primer

N. ANCHOR METHOD

- 1. Requirements for anchor method
 - a. Hollow Masonry: Toggle bolts or spider type expansion anchors
 - b. Solid Masonry (excluding concrete): Steel expansion bolts
 - c. New Concrete: Preset inserts with machine screws and bolts
 - d. Existing Concrete: Steel expansion bolts or explosive powder driven inserts
 - e. Wood Surfaces: Wood screws
 - f. Steel: Welded threaded studs or galvanized steel clamps
 - g. Light Steel: Sheet metal screws
 - h. Adequately rated
 - i. Verify use of explosive powder driven inserts in occupied buildings

O. FUSES

- 1. Requirements for anchor fuses
 - a. Submittal
 - b. Bussmann
 - c. Gould Shawmut
 - d. Littelfuse, Inc
 - e. Provide three (3) spare fuses for each type and rating installed
 - f. Provide spare fused cabinet
 - g. Each device with fuses labeled with phenolic or etched part of nameplate on the outside and Kroy type label inside with the fuse rating installed

P. FIRE SEAL

- 1. Requirements for fire seal
 - a. Meet requirements of jurisdictional authority
 - b. Installed to maintain rating

Q. ACCESS PANEL

- 1. Requirements for access panel
 - a. Submittal
 - b. Milcor, Nystrom, Karp, J.L. Industries, or Williams Brothers
 - c. Milcor Style M for masonry and drywall construction; equal to Milcor Style K for plastered masonry walls and ceilings
 - d. Stainless steel panels used in ceramic tile or glazed structural tile
 - e. Doors 14 gauge minimum sheet metal, 16 gauge frames of cadmium plated or galvanized construction
 - f. Doors with expanded plaster rings where located in plaster walls or flanged finish where located in drywall or block construction
 - g. Panels spring hinges with screwdriver locks in non-public areas
 - h. Key lock, keyed alike, for panels in public areas
 - i. Prime painted or rust inhibitive paint finish
 - j. UL labeled when in fire rated construction, 1-1/2 hour rating
 - k. Minimize need by planning junction boxes and pull boxes in locations other than dry wall ceilings and walls
 - l. Coordinate with architect locations
 - m. Coordinate fire rating with installed location

R. EQUIPMENT IDENTIFICATION

- 1. Requirements for equipment identification
 - a. Submittal

- b. Identify electrical equipment with permanently attached engraved phenolic or etched plates per details below, attached with minimum four (4) sheet metal screws
- c. Factory nameplates attached to each piece of distribution equipment and major system component identifying manufacturer's name, address, model and serial number for each component
- d. Tape Labels: Kroy type adhesive tape, with 3/8 inch black letters on white background for "normal" and red letters on white background for "emergency"
- e. Dymo tape not allowed.
- f. Color identification: normal power (boxes: none; labels: black with white letters), life safety (boxes: orange; labels: orange with black letters), standby (boxes: yellow or labels: yellow with black letters), UPS (boxes: black; labels: white with black letters), fire alarm (red), IT (per CCSD), educational intercommunication system (green), security (white), and sound system (per CCSD)

S. NAMEPLATE DETAILS

1. Requirements for nameplates
 - a. Submittal
 - b. Include all that apply

1/4 INCH 

EQUIPMENT TAG [P-1]

DISTRIBUTION BRANCH [NORMAL]

OVERCURRENT RATING AND TYPE [100A FRS-R OR 100A3P TYPE FH]

FED FROM [PANELBOARD H1A-1,3,5] IN ROOM [NUMBER OR NAME]

[18,000 AIC]

CALCULATED AVAILABLE SHORT CIRCUIT CURRENT [11,000] AMPERES

DATE OF CALCULATION [8/20/2018]

[480] VOLTS, 60 HERTZ

FEEDER OR BRANCH CIRCUIT: [COPPER 3#1(THHN),1#8G(THHN),1-1/2 INCH CONDUIT]

INSTALLED [8/20/2018]

GENERAL NOTES

1. MINIMUM TEXT HEIGHT 1/8 INCH, UNLESS NOTED OTHERWISE.
2. NAMEPLATE WHERE EQUIPMENT IS LOCATED EXTERIOR TO BE MADE OF METAL WITH ETCHED LETTERING AND ATTACHED WITH FOUR (4) SCREWS.
3. NAMEPLATE WHERE EQUIPMENT IS LOCATED INTERIOR TO BE PHENOLIC WITH ENGRAVED LETTERING AND ATTACHED WITH ADHESIVE TAPE.
4. COLORS:
 - BLACK LETTERS ON WHITE BACKGROUND FOR NORMAL
 - BLACK LETTERS ON ORANGE BACKGROUND FOR LIFE SAFETY OR EMERGENCY
 - BLACK LETTERS ON YELLOW BACKGROUND FOR STANDBY
5. FILL IN SPECIFIC INFORMATION WHERE THERE ARE BRACKETS.

**NAMEPLATE DETAIL-
DISCONNECT SWITCH OR
ENCLOSED CIRCUIT BREAKER**

#

SHT#

SCALE: NONE

1/2 INCH

1/4 INCH

PANELBOARD [H1A]

DISTRIBUTION BRANCH [NORMAL]

[225] AMPERE [COPPER] BUS, [FULL SIZE] NEUTRAL BUS

FED FROM [MAIN DISTRIBUTION BOARD MDB] IN ROOM [NUMBER OR NAME]

[18,000 AIC] FULLY RATED

CALCULATED AVAILABLE SHORT CIRCUIT CURRENT [11,000] AMPERES

DATE OF CALCULATION [04/06/2013]

[480Y/277] VOLTS, [3] PHASE, [4] WIRE, 60 HERTZ

FEEDER OR BRANCH CIRCUIT: [COPPER 4#4/0(THNN),1#4G(THNN),2-1/2 INCH CONDUIT]

COLOR CODING OF PHASE CONDUCTORS

PHASE A [BROWN]

PHASE B [ORANGE]

PHASE C [YELLOW]

NEUTRAL [GREY]

GROUND [GREEN]

INSTALLED [08/20/2018]

GENERAL NOTES

1. MINIMUM TEXT HEIGHT 1/8 INCH, UNLESS NOTED OTHERWISE.
2. NAMEPLATE WHERE EQUIPMENT IS LOCATED EXTERIOR TO BE MADE OF METAL WITH ETCHED LETTERING AND ATTACHED WITH FOUR (4) SCREWS.
3. NAMEPLATE WHERE EQUIPMENT IS LOCATED INTERIOR TO BE PHENOLIC WITH ENGRAVED LETTERING AND ATTACHED WITH ADHESIVE.
4. COLORS:
 - BLACK LETTERS ON WHITE BACKGROUND FOR NORMAL
 - BLACK LETTERS ON ORANGE BACKGROUND FOR LIFE SAFETY OR EMERGENCY
 - BLACK LETTERS ON YELLOW BACKGROUND FOR STANDBY
5. FILL IN SPECIFIC INFORMATION WHERE THERE ARE BRACKETS.

NAMEPLATE DETAIL- PANELBOARD



SCALE: NONE

1/2 INCH
1/4 INCH

DISTRIBUTION BOARD [MDB]

DISTRIBUTION BRANCH [NORMAL]

[4000] AMPERE [COPPER] BUS, [FULL SIZE] NEUTRAL BUS

FED FROM [XCEL PAD MOUNTED TRANSFORMER] LOCATED [SOUTHEAST OF BUILDING]

[65,000 AIC] FULLY RATED
CALCULATED AVAILABLE SHORT CIRCUIT CURRENT [42,400] AMPERES
DATE OF CALCULATION [04/06/2013]

[480Y/277] VOLTS, [3] PHASE, [4] WIRE, 60 HERTZ

FEEDER OR BRANCH CIRCUIT: [COPPER 11(4#500(THHN),3-1/2 INCH CONDUIT)]

COLOR CODING OF PHASE CONDUCTORS

PHASE A [BROWN]	PHASE B [ORANGE]	PHASE C [YELLOW]
NEUTRAL [GREY]	GROUND [N/A]	

INSTALLED [08/20/2018]

GENERAL NOTES

1. MINIMUM TEXT HEIGHT 1/8 INCH, UNLESS NOTED OTHERWISE.
2. NAMEPLATE WHERE EQUIPMENT IS LOCATED EXTERIOR TO BE MADE OF METAL WITH ETCHED LETTERING AND ATTACHED WITH FOUR (4) SCREWS.
3. NAMEPLATE WHERE EQUIPMENT IS LOCATED INTERIOR TO BE PHENOLIC WITH ENGRAVED LETTERING AND ATTACHED WITH ADHESIVE.
4. COLORS:
 - BLACK LETTERS ON WHITE BACKGROUND FOR NORMAL
 - BLACK LETTERS ON ORANGE BACKGROUND FOR LIFE SAFETY OR EMERGENCY
 - BLACK LETTERS ON YELLOW BACKGROUND FOR STANDBY
5. FILL IN SPECIFIC INFORMATION WHERE THERE ARE BRACKETS.

NAMEPLATE DETAIL- DISTRIBUTION BOARD



SCALE: NONE

1/4 INCH

[PANELBOARD H1A]

OVERCURRENT RATING AND TYPE [225A FRS-R OR 225A3P TYPE DJ]
CIRCUIT BREAKER SETTINGS:

	LT PICKUP: [1.0]	LT BAND: [4]
	ST PICKUP: [2.5]	ST BAND: [INST, I ² T OUT]
INST.	PICKUP: [12]	
	GF: [0.2]	GFD: [0.2, I ² T OUT]

[480] VOLTS, [3] PHASE, [4] WIRE, 60 HERTZ

FEEDER OR BRANCH CIRCUIT: [COPPER 4#4/0(THHN),1#4G(THHN),2-1/2 INCH CONDUIT]

INSTALLED [8/20/2018]

GENERAL NOTES

1. MINIMUM TEXT HEIGHT 1/8 INCH, UNLESS NOTED OTHERWISE.
2. NAMEPLATE WHERE EQUIPMENT IS LOCATED EXTERIOR TO BE MADE OF METAL WITH ETCHED LETTERING AND ATTACHED WITH FOUR (4) SCREWS.
3. NAMEPLATE WHERE EQUIPMENT IS LOCATED INTERIOR TO BE PHENOLIC WITH ENGRAVED LETTERING AND ATTACHED WITH ADHESIVE.
4. COLORS:
 - BLACK LETTERS ON WHITE BACKGROUND FOR NORMAL
 - BLACK LETTERS ON ORANGE BACKGROUND FOR LIFE SAFETY OR EMERGENCY
 - BLACK LETTERS ON YELLOW BACKGROUND FOR STANDBY
5. FILL IN SPECIFIC INFORMATION WHERE THERE ARE BRACKETS.

NAMEPLATE DETAIL- LOAD ON DISTRIBUTION BOARD



SCALE: NONE

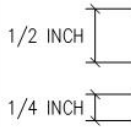

TRANSFORMER [KT-L1A]
 DISTRIBUTION BRANCH [NORMAL]

[75] KVA, [3] PHASE, [480] VOLTS [DELTA], 60 HERTZ IN, [208Y/120] VOLTS OUT, 60 HERTZ

K-RATING: [13]

FED FROM [H1A] LOCATED [IN MAIN ELECTRICAL ROOM]
 LOAD [L1A] LOCATED [IN ELECTRICAL ROOM 110]

%Z: [3.00]
 CALCULATED AVAILABLE SHORT CIRCUIT CURRENT [6,939] AMPERES
 DATE OF CALCULATION [08/20/2018]

FEEDER IN: [3#2,1#6G,1-1/4 INCH CONDUIT]

FEEDER OUT: [3#400,2#300N,1#1G,3-1/2 INCH CONDUIT]

GROUNDING ELECTRODE CONDUCTOR: [1/0]

INSTALLED [08/20/2018]

GENERAL NOTES

1. MINIMUM TEXT HEIGHT 1/8 INCH, UNLESS NOTED OTHERWISE.
2. NAMEPLATE WHERE EQUIPMENT IS LOCATED EXTERIOR TO BE MADE OF METAL WITH ETCHED LETTERING AND ATTACHED WITH FOUR (4) SCREWS.
3. NAMEPLATE WHERE EQUIPMENT IS LOCATED INTERIOR TO BE PHENOLIC WITH ENGRAVED LETTERING AND ATTACHED WITH ADHESIVE.
4. COLORS:
 - BLACK LETTERS ON WHITE BACKGROUND FOR NORMAL
 - BLACK LETTERS ON ORANGE BACKGROUND FOR LIFE SAFETY OR EMERGENCY
 - BLACK LETTERS ON YELLOW BACKGROUND FOR STANDBY
5. FILL IN SPECIFIC INFORMATION WHERE THERE ARE BRACKETS.

**NAMEPLATE DETAIL-
 DRY TYPE TRANSFORMER**



SCALE: NONE

1/2 INCH

GENERATOR [GEN1]

SITE RATING: [800] KW/[1000] KVA, [3] PHASE, [480Y/277] VOLTS, [3] PHASE, [4] WIRE, 60 HERTZ

FEEDS [GDB] LOCATED [IN EMERGENCY ELECTRICAL ROOM]

SUB-TRANSIENT REACTANCE: [0.12]

CALCULATED AVAILABLE SHORT CIRCUIT CURRENT [10,023] AMPERES

DATE OF CALCULATION [08/20/2018]

FEEDER OUT: [COPPER 5(4#400)(THHN),1#4/0G,3-1/2 INCH CONDUIT)]

GROUND ELECTRODE CONDUCTOR: [3/0 (COPPER)]

NEUTRAL: [BONDED TO ENCLOSURE]

INSTALLED [08/20/2018]

GENERAL NOTES

1. MINIMUM TEXT HEIGHT 1/8 INCH, UNLESS NOTED OTHERWISE.
2. NAMEPLATE WHERE EQUIPMENT IS LOCATED EXTERIOR TO BE MADE OF METAL WITH ETCHED LETTERING AND ATTACHED WITH FOUR (4) SCREWS.
3. NAMEPLATE WHERE EQUIPMENT IS LOCATED INTERIOR TO BE PHENOLIC WITH ENGRAVED LETTERING AND ATTACHED WITH ADHESIVE.
4. COLORS:
-BLACK LETTERS ON ORANGE BACKGROUND FOR LIFE SAFETY OR EMERGENCY AND STANDBY
OR
-BLACK LETTERS ON YELLOW BACKGROUND FOR STANDBY ONLY
5. FILL IN SPECIFIC INFORMATION WHERE THERE ARE BRACKETS.

NAMEPLATE DETAIL- GENERATOR



SCALE: NONE

1/2 INCH
1/4 INCH

TRANSFER SWITCH [ATS1]

DISTRIBUTION BRANCH [LIFE SAFETY]

[100] AMPERE, [4] POLE, [480Y/277] VOLT, [3] PHASE, 60 HERTZ
NORMAL SOURCE: [MDB] LOCATED [IN MAIN ELECTRICAL ROOM]
EMERGENCY SOURCE: [GDB] LOCATED [IN EMERGENCY ELECTRICAL ROOM]
LOAD: [LL1A]

[30,000] AIC
CALCULATED AVAILABLE SHORT CIRCUIT CURRENT [18,550] AMPERES
DATE OF CALCULATION [08/20/2013]

NORMAL FEEDER IN: [4#1,1#8G,2 INCH CONDUIT]
EMERGENCY FEEDER IN: [4#1,1#8G,2 INCH CONDUIT]
FEEDER OUT: [4#1,1#8G,2 INCH CONDUIT]

INSTALLED [08/20/2018]

GENERAL NOTES

1. MINIMUM TEXT HEIGHT 1/8 INCH, UNLESS NOTED OTHERWISE.
2. NAMEPLATE WHERE EQUIPMENT IS LOCATED EXTERIOR TO BE MADE OF METAL WITH ETCHED LETTERING AND ATTACHED WITH FOUR (4) SCREWS.
3. NAMEPLATE WHERE EQUIPMENT IS LOCATED INTERIOR TO BE PHENOLIC WITH ENGRAVED LETTERING AND ATTACHED WITH ADHESIVE.
4. COLORS:
 - BLACK LETTERS ON WHITE BACKGROUND FOR NORMAL
 - BLACK LETTERS ON ORANGE BACKGROUND FOR LIFE SAFETY OR EMERGENCY
 - BLACK LETTERS ON YELLOW BACKGROUND FOR STANDBY
5. FILL IN SPECIFIC INFORMATION WHERE THERE ARE BRACKETS.

NAMEPLATE DETAIL- TRANSFER SWITCH



SCALE: NONE

T. CIRCUIT IDENTIFICATION

1. Requirements for circuit identification
 - a. Identify feeder junction boxes and pull boxes with designation of panelboard/switchboard source as "FROM" and load served as "TO" with permanent labels
 - b. Identify pull and junction boxes with the designation of panelboard, the circuit number of each circuit, and voltage contained therein, with permanent marker on box and cover
 - c. Identify circuits in conduits entering outlet boxes with the designation of panelboard and the circuit number of each circuit contained therein, with permanent marker
 - d. Wire and Cable Markers: Brady type permanently printed vinyl cloth adhesive backed wire markers

U. WARNING SIGN

1. Requirements for warning sign
 - a. Submittal
 - b. Arc flash per detail below

The diagram shows a rectangular warning sign with a black border. At the top left is a warning triangle icon. To its right is the text "[DANGER][WARNING]" in a large, bold font. Below this is "[Dangerous!][Level [#]]" in a slightly smaller bold font. The next line is "Arc Flash and Shock Hazard" in a medium-sized bold font. Below that is "[ENERGIZED WORK PROHIBITED][Appropriate PPE Required]" in a medium-sized bold font. The main body of the sign contains technical data: "[EQUIPMENT NAME]" on the left and "Available Fault: [##.## kA]" on the right. Below this are several lines of data: "Shock Risk: [### VAC]", "Arc Flash Boundry: [## in]", "Incident Energy at: [## in]", "Minimum Arc Rating: [### cal/cm^2]", "Limited Approach: [## in]", and "Arc Duration: [### sec]". At the bottom of the sign, it says "Date of Study: [MM/DD/YYYY] for: [INSTALLATION LOCATION NAME]" and "By: [CALCULATION COMPANY NAME] Project #: [# FOR CALCULATIONS]".

Callouts on the right side of the sign specify font requirements: "Arial, 22, Bold" for the top header, "Arial, 18, Bold" for the level indicator, "Arial, 12, Bold" for the hazard text, and "Arial, 12, Bold" for the prohibition text. A callout on the left side specifies "Arial Narrow, 10, Bold" for the equipment name.

GENERAL NOTES

1. LABELS PRINTED WITH COLOR LASER PRINTER ON THE AVERY 5524 WEATHER RESISTANT VINYL SELF ADHESIVE MATERIAL.
2. INSTALL LABELS ON ELECTRICAL DISTRIBUTION EQUIPMENT.

ARC FLASH AND SHOCK WARNING SIGN DETAIL

At the bottom left of the sign detail is a circular stamp containing "# SHT#". To its right, it says "SCALE: NONE".

END OF SECTION

PAGE INTENTIONALLY BLANK

SECTION 26 05 26

GROUNDING AND BONDING FOR ELECTRICAL SYSTEMS

PART 1 – GENERAL

A. SUBJECT TO CHANGE

1. These standards are subject to change. Verify that the latest are being used. Product manufacturers listed is the basis of design or equivalent unless noted otherwise.

B. SUMMARY – SECTION INCLUDES

1. Grounding and Bonding for Electrical Systems

C. GROUND TESTING

1. Requirements for ground testing
 - a. Submittal
 - b. Independent testing agency qualifications (NETA or NRTL member)
 - c. Vertiv or RESA Power
 - d. Continuity
 - e. Service ground less than 10 ohms

D. GROUND CONNECTION GENERAL

1. Requirements for ground connection general
 - a. Make connections so the possibility of galvanic action or electrolysis is minimized
 - b. Select connectors, connection hardware, conductors, and connection methods so metals in direct contact with earth will be galvanically compatible
 - c. Use electroplated or hot tin coated materials to assure high conductivity and to make contact points closer in order of galvanic series
 - d. Make connections at points of clean, bare metal

E. GROUND CLAMP AND HUB

1. Requirements for ground clamp and hub
 - a. Burndy
 - b. Thomas Betts
 - c. Grounding bushings, grounding studs, and grounding jumpers at switchboards, panelboards, pull boxes, and other electrical enclosures
 - d. Tighten screws and bolts for grounding and bonding connectors and terminals according to manufacturers published torque tightening values
 - e. Ground connections to equipment and ground buses shall be by ground lugs or clamps

F. EXOTHERMIC WELD

1. Requirements for exothermic weld
 - a. Enrico Cadweld
 - b. Use for connections to structural steel and for underground connections
 - c. Comply with manufacturer's written instructions
 - d. Welds that are puffed up or that show convex surfaces indicating improper cleaning are not acceptable
 - e. Installer shall be certified
 - f. Below grade connections installed under this contract shall be left exposed for inspection by the designer prior to backfilling

G. MADE ELECTRODE

1. Requirements for made electrode

- a. Blackburn
- b. Copper-clad, 120 inch long, 3/4 inch diameter
- c. Moisture protection, where insulated grounding conductors are connected to grounding rods or grounding buses, insulate entire area of connection and seal against moisture penetration of insulation and cable

H. COMPRESSION FITTING

1. Requirements for compression fitting
 - a. Submittal
 - b. Burndy/Hyground
 - c. Hydraulic compression tools to provide correct circumferential pressure for compression connectors
 - d. Tools and dies recommended by manufacturer of connectors
 - e. Embossing die code or other standard method to make a visible indication that a connector has been adequately compressed on grounding conductor
 - f. Terminations, number 8 AWG and larger, use pressure type grounding lugs, number 10 AWG and smaller grounding conductors may be terminated with pressure type connectors

I. GENERAL GROUNDING

1. Requirements for general grounding
 - a. Ground connections accessible locations to allow for inspection, testing, and maintenance
 - b. Ground conductor in all conduits, except electrical service feeder
 - c. Clean all conductive surfaces on equipment to be grounded, to assure good electrical continuity
 - d. Avoid obstructing access or placing conductors where they may be subjected to strain, impact, or damage
 - e. Conductors shall be formed to the contour of equipment and firmly supported
 - f. Underground grounding conductors bury at least 24 inches below grade, if installed near the base of a structure shall be in earth and as far from the structure as the excavation permits but not closer than 6 inches
 - g. Metal water service pipe, dielectric main water fitting is installed, connect grounding conductor to street side of fitting no jumper across dielectric fittings
 - h. Water meter piping, bonding jumpers to electrically bypass water meters, connect to pipe with grounding clamp connectors
 - i. Grounding rods, drive until tops are 2 inches below finished floor or final grade connected by exothermic weld without damaging copper coating or exposing steel
 - j. Equipment grounding conductors, separate equipment grounding conductor with all feeder and branch circuit conductors, properly sized common equipment grounding conductor may be used for multiple feeders or branch circuits routed within a single conduit
 - k. Connect the ground terminal on each non isolated ground type outlet receptacle to the branch circuit grounding conductor and to the metallic raceway system with bonding jumpers
 - l. Connect the grounding stud on each luminaire to the branch circuit grounding conductor and to the metallic raceway system with bonding jumpers
 - m. Connections to enclosures without ground buses or ground terminals shall be by clamp type lugs added under permanent assembly bolts or under new bolts drilled and added through enclosures or by grounding locknuts or bushings
 - n. Ground cable connections against gaskets, paint, or varnish; or on bolts holding removable access covers shall not be permitted

J. BUILDING BONDING

1. Metallic building components, bond all metal piping, metal air ducts, and exposed interior structural steel to grounding electrode system

K. MAIN ELECTRICAL SERVICE GROUNDING

1. Requirements for main electrical service grounding
 - a. Service equipment building ground, incoming main water line with heavy duty ground clamp, tri-pod (minimum 25 feet apart) made electrodes outside foundation of building, building steel, ground loop, and Ufer
 - b. Ufer ground (concrete encased grounding electrode), bond grounding conductor to reinforcing steel in at least 4 locations, and to anchor bolts and utilize footer under wall of main electrical room

L. POLE MOUNTED LUMINAIRE GROUNDING

1. Requirements for pole mounted luminaire grounding
 - a. Metal poles supporting outdoor luminaires, ground pole to metal reinforcing within concrete pole base using number 6 AWG conductor, exothermic weld or clamp connection
 - b. Precast and cast concrete pole bases for metal poles supporting outdoor luminaires, ground pole to a local ground rod within 6 feet of pole base with number 6 AWG conductor, electrode, exothermic weld connection

M. LOW VOLTAGE DISTRIBUTION TRANSFORMER GROUNDING

1. Requirements for low voltage distribution transformer grounding
 - a. Copper bonding jumper to ground the secondary neutral of transformers to the secondary ground within the transformer
 - b. Grounding electrode conductor to bond the secondary ground of the transformer to the closest building steel or metal water pipe
 - c. Supplemental bonding to building grounding electrode system and the grounding conductor of the primary feeder

N. ISOLATION GROUNDING

1. Isolated equipment grounding conductor, terminate at the isolated equipment grounding conductor terminal of the isolated ground bus in panelboard and to applicable derived system or service

O. GENERATOR GROUNDING

1. Requirements for generator grounding
 - a. Ground the engine generator frame and enclosure using an equipment grounding conductor
 - b. Ground to made electrode (ground rod)

P. COMMUNICATION SYSTEM GROUNDING

1. Requirements for communication system grounding
 - a. Grounding means for the communication systems per the system manufacturer's recommendations
 - b. Main communications service equipment grounding means minimum number 4 AWG, green, insulated, copper grounding conductor connected to the main electrical service equipment ground bus
 - c. Telephone terminal boards and other remote communications equipment grounding means, but not be limited to a minimum number 6 AWG, green, insulated, copper

grounding conductor connected to the equipment ground bus in the low voltage

panelboard serving the telephone equipment or branch circuits in the immediate vicinity

- d. Communication equipment ground bus to be 12 inches long, 4 inches tall, 1/4 inch thick with tapped holes
- e. Route the telephone equipment grounding conductors in 3/4 inch conduit by the most direct means from the telephone equipment ground bus to the electrical equipment grounding system
- f. Permanent, engraved labels at the telephone equipment ground buses identifying these as the equipment grounding means and identifying the location of connection of the grounding conductors to the electrical equipment grounding system

END OF SECTION

SECTION 26 05 73
POWER SYSTEM STUDIES

PART 1 – GENERAL

A. SUBJECT TO CHANGE

1. These standards are subject to change. Verify that the latest are being used. Product manufacturers listed is the basis of design or equivalent unless noted otherwise.

B. SUMMARY – SECTION INCLUDES

1. Power System Studies

C. REQUIRED INFORMATION FROM CONTRACTOR

1. Submittals of self-adhesive weatherproof vinyl labels (Avery 5524 template)
2. Provide distances, conduit type, circuit breaker types, etc. marked up on a comprehensive one-line diagram to project engineer, including the following
 - a. Ampere rating
 - b. Interrupting ampere rating
 - c. Frame size, sensor or plug rating
 - d. Trip settings
 - e. Fault available at line terminals
 - f. Ground fault interrupter trip settings
 - g. Type of cable, cable size and cable length from load terminals to next termination point

D. REQUIRED FROM PROJECT ENGINEER

1. Comprehensive list of required information for the contractor
2. Use ETAP or SKM Systems Analysis computer program
3. PDF file with the arc flash labels that match the detail in 26 05 00 that can be printed on Avery 5524 vinyl template sheets
4. Label for each electrical distribution component, including multiple labels for equipment with more than one section
5. Documentation of the settings of adjustable circuit breakers as a result of coordination study prior to required testing

E. REQUIRED INSTALLATION BY CONTRACTOR

1. Setting of adjustable circuit breakers per project engineer coordination study prior to testing
2. Clean surface of electrical distribution equipment and apply labels

END OF SECTION

PAGE INTENTIONALLY BLANK

SECTION 26 09 15
ELECTRONIC POWER MONITOR

PART 1 – GENERAL

A. SUBJECT TO CHANGE

1. These standards are subject to change. Verify that the latest are being used. Product manufacturers listed is the basis of design or equivalent unless noted otherwise.

B. SUMMARY – SECTION INCLUDES

1. Electronic Power Monitor

C. ELECTRONIC POWER MONITOR

1. Requirements for electronic power monitor
 - a. Submittal
 - b. Manufactured by General Electric or Square D
 - c. Current, Voltage, kW, kVA
 - d. Digital communication capability, open protocol
 - e. Main service equipment incoming

B. PHASE MONITORING

1. Requirements for phase monitoring
 - a. Submittal
 - b. Time Mark (no equivalent)
 - c. Appropriate voltage
 - d. Connected to 20 ampere, 3 pole circuit breaker in closest to main distribution board panelboard
 - e. Mounted in hinged box in main electrical room
 - f. 3/4 inch conduit to security panel
 - g. Part of service upgrades, provide new at new service and remove existing

END OF SECTION

PAGE INTENTIONALLY BLANK

SECTION 26 09 43

NETWORK LIGHTING CONTROL

PART 1 – GENERAL

A. SUBJECT TO CHANGE

1. These standards are subject to change. Verify that the latest are being used. Product manufacturers listed is the basis of design or equivalent unless noted otherwise.

B. SUMMARY – SECTION INCLUDES

1. Network Lighting Control

C. NETWORK LIGHTING CONTROL

1. Requirements for network lighting control
 - a. Submittal
 - b. Manufactured by Acuity (nLight) or Cooper or Leviton
 - c. Compatible with controlled luminaires
 - d. Wireless lighting control is prohibited
 - e. Includes occupancy and vacancy sensors, dimmers, switches, daylight sensors, etc.
 - f. Passive infrared and ultrasonic or audio sensing dual technology products
 - g. Spare components, 10 percent of each component installed, minimum of two (2)
 - h. Locate sensing devices per manufacturer's recommendations
 - i. Locate lighting control panels in electrical rooms
 - j. Owners training

END OF SECTION

PAGE INTENTIONALLY BLANK

SECTION 26 12 13

PAD MOUNTED LIQUID FILLED MEDIUM VOLTAGE TRANSFORMER

PART 1 – GENERAL

A. SUBJECT TO CHANGE

1. These standards are subject to change. Verify that the latest are being used. Product manufacturers listed is the basis of design or equivalent unless noted otherwise.

B. SUMMARY – SECTION INCLUDES

1. Pad Mounted Liquid Filled Medium Voltage Transformer

C. PAD MOUNTED LIQUID FILLED MEDIUM VOLTAGE TRANSFORMER

1. Requirements for pad mounted liquid filled transformer
 - a. Submittal
 - b. Manufactured by ABB, Cooper Power Systems (RTE), Cutler-Hammer, or Equivalent
 - c. Tamperproof/lockable enclosure
 - d. Concrete pad or vault
 - e. Primary bushings (loop or radial feed)
 - f. Load break switch actuator
 - g. Bayonet or other fuse assemblies
 - h. Lightning arrestors
 - i. Tap changer
 - j. Grounding pad
 - k. Parking stands
 - l. Low voltage spades
 - m. Thermometer
 - n. Vacuum gage
 - o. Pressure relief device
 - p. Drain valve with sampling device
 - q. Environmentally safe liquid
 - r. Voltages as required
 - s. 95 kV BIL
 - t. Minimum impedance 2 percent
 - u. Maximum impedance 4 percent
 - v. 185 degree Celsius windings (aluminum or copper)
 - w. Copper terminal lug landings and bus extensions
 - x. Grounding pads in opposite corners of the field wiring sections
 - y. Cooling fans as required
 - z. Olive green highly resistant to corrosion paint
 - aa. Tested

END OF SECTION

PAGE INTENTIONALLY BLANK

SECTION 26 12 19

ELECTRICAL SERVICE ENTRANCE

PART 1 – GENERAL

A. SUBJECT TO CHANGE

1. These standards are subject to change. Verify that the latest are being used. Product manufacturers listed is the basis of design or equivalent unless noted otherwise.

B. SUMMARY – SECTION INCLUDES

1. Electrical Service Entrance

C. ELECTRICAL SERVICE ENTRANCE

1. Requirements for electrical service entrance
 - a. Submittal
 - b. Manufactured by American Midwest Power or Erickson Electrical Equipment Company
 - c. Connection cabinet for XCEL service area
 - d. EUSERC cabinet for Core service area
 - e. Plated copper buses
 - f. Minimum of 65,000 AIC or greater as required
 - g. Mounted on concrete pad
 - h. Utility metering exterior of building

END OF SECTION

PAGE INTENTIONALLY BLANK

SECTION 26 22 00

DRY TYPE TRANSFORMER

PART 1 – GENERAL

A. SUBJECT TO CHANGE

1. These standards are subject to change. Verify that the latest are being used. Product manufacturers listed is the basis of design or equivalent unless noted otherwise.

B. SUMMARY – SECTION INCLUDES

1. Dry Type Transformer

C. DRY TYPE TRANSFORMER

1. Requirements for dry type transformer
 - a. Submittal
 - b. Manufactured by Powersmiths or Mirus (no equivalent)
 - c. Copper windings
 - d. Maximum 115 degree Celsius rise windings
 - e. K-9 rated for all transformers, except K-13 rated for transformers supporting a majority of electronic equipment
 - f. Meet current energy code
 - g. NEMA 1 enclosures typical, rain shield for transformers located on the exterior or wet location
 - h. Floor mounted on concrete pad and rubber vibration absorbing mounts
 - i. Suspended 75 kVA or less with CCSD review of suspension method
 - j. Secondary overcurrent protection of a single device
 - k. The maximum sound level rating of 0.5 to 9 kVA - 40 dBa, 10 to 50 kVA - 45 dBa, 51 to 150 kVA - 50 dBa, 151 to 300 kVA - 55 dBa, 301 to 500 kVA - 60 dBa
 - l. Replace noisy transformers

END OF SECTION

PAGE INTENTIONALLY BLANK

SECTION 26 24 13

SWITCHBOARD

PART 1 – GENERAL

A. SUBJECT TO CHANGE

1. These standards are subject to change. Verify that the latest are being used. Product manufacturers listed is the basis of design or equivalent unless noted otherwise.

B. SUMMARY – SECTION INCLUDES

1. Switchboard

C. SWITCHBOARD

1. Requirements for switchboard
 - a. Submittal
 - b. Manufactured by ABB, Square D and Siemens (no equivalent)
 - c. Main service entrance distribution equipment or sub-distribution equipment
 - d. Plated copper buses
 - e. Main protective devices 800 amperes and larger, adjustable trip circuit breaker with (where required) ground fault
 - f. Branch protective devices 250 amperes and larger, 80 percent rated electronic trip circuit breakers with long time, short time, instantaneous, ground fault (where required) trip devices
 - g. Circuit breakers with frame sizes above 100 amperes shall have a single magnetic trip adjustment located on the front of the circuit breaker
 - h. Minimum of 50,000 AIC or greater as required
 - i. Mounted on concrete pad
 - j. Setting of devices per power system studies
 - k. Main located in dedicated electrical room or on the exterior of the building with utility metering
 - l. No conduits shall penetrate the top of a NEMA 3R switchboard

m. Nomenclature per below

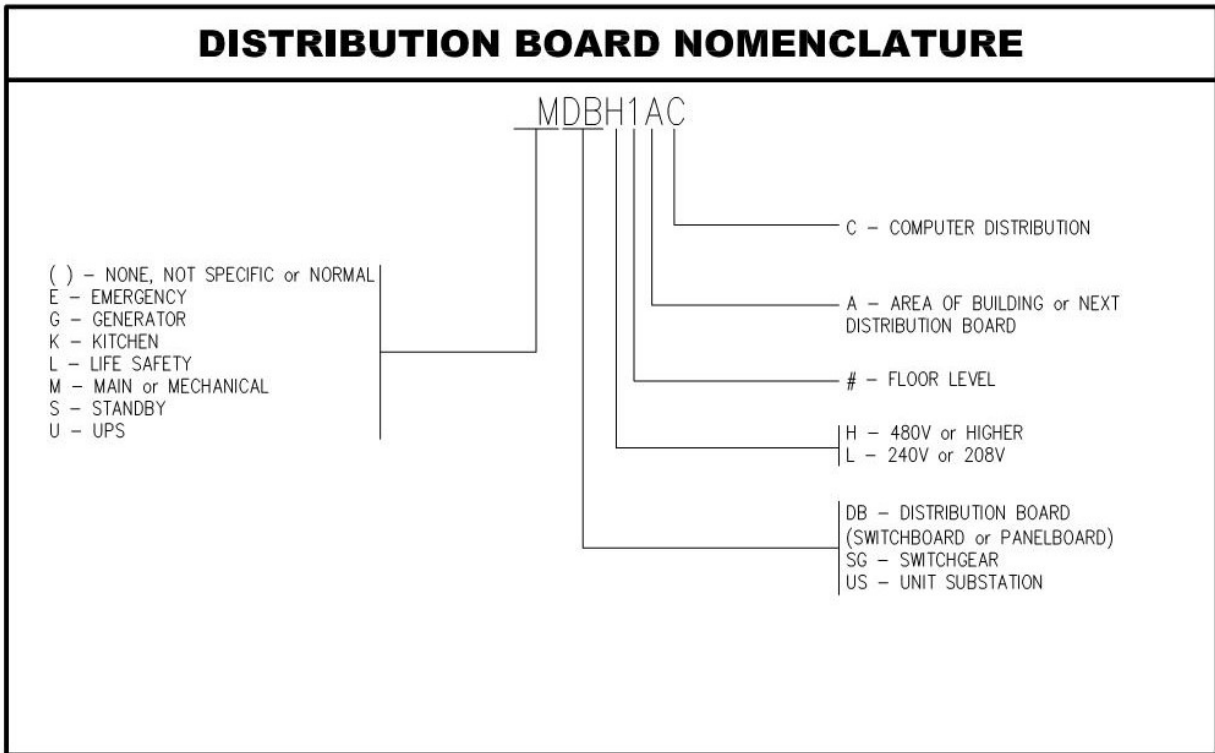

END OF SECTION

SECTION 26 24 16

PANELBOARD

PART 1 – GENERAL

A. SUBJECT TO CHANGE

1. These standards are subject to change. Verify that the latest are being used. Product manufacturers listed is the basis of design or equivalent unless noted otherwise.

B. SUMMARY – SECTION INCLUDES

1. Panelboard

C. PANELBOARD

1. Requirements for panelboard
 - a. Submittal
 - b. Manufactured by ABB or Square D or Siemens (no equivalent)
 - c. 208Y/120V (ABB-ReliaGear or Square D-N series or Siemens-P series)
 - d. 480Y/277V branch panelboards (ABB-ReliaGear or Square D-N series or Siemen-P series)
 - e. Distribution circuit breaker panelboard (ABB-ReliaGear neXT, Square D-I-Line type or Siemens-P series)
 - f. Fusible switch type distribution panelboards (ABB, or Square D-type QMB or Siemens-P series)
 - g. 100 percent rated copper busing
 - h. 200 percent rated neutral busing for panelboards supporting majority of electronic equipment
 - i. 100 percent rated isolation ground bus where used
 - j. Bolt on circuit breakers
 - k. Circuit breakers with frame sizes above 100 amperes shall have a single magnetic trip adjustment located on the front of the circuit breaker
 - l. Hinged trim covers for branch circuit panelboards
 - m. Multi-section panelboards same height
 - n. NEMA 1 enclosures typically, NEMA 3R for wet or exterior locations, or NEMA 12 in pool equipment rooms
 - o. Full height busing
 - p. Fully rated AIC
 - q. Flush mounting to maintain fire rating of wall
 - r. Spare conduits stubbed to above accessible ceiling with 90 degrees, capped for flush mounted panelboards equal to 10 percent of the installed conduits
 - s. Panelboard directories with type written description of loads with spares and spaces written with pencil
 - t. New designs to include 20 percent spare capacity, 10 percent spare circuit breakers and 10 percent spaces
 - u. Located in dedicated electrical room, except in kitchens, laboratories, or mechanical rooms
 - v. No conduits shall penetrate the top of a NEMA 3R panelboard

w. Nomenclature per below

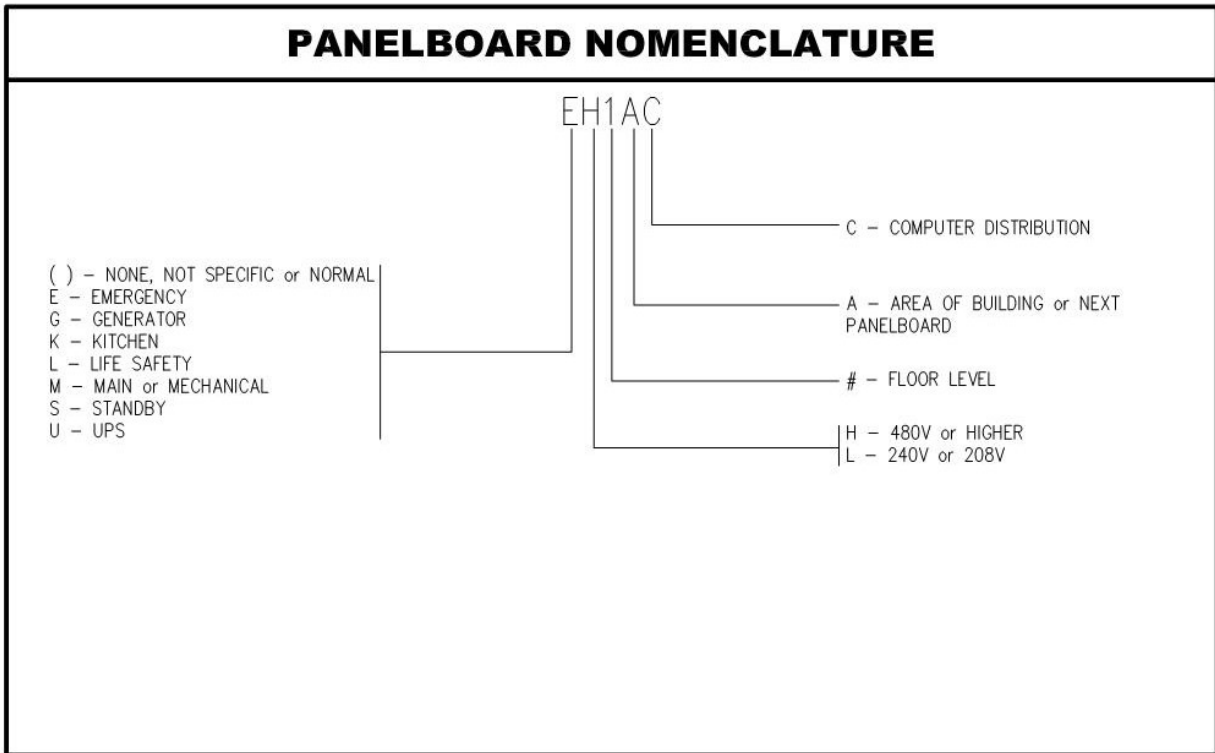

END OF SECTION

SECTION 26 27 26

WIRING DEVICES AND DELIVERY SYSTEMS

PART 1 – GENERAL

A. SUBJECT TO CHANGE

1. These standards are subject to change. Verify that the latest are being used. Product manufacturers listed is the basis of design or equivalent unless noted otherwise.

B. SUMMARY – SECTION INCLUDES

1. Receptacle, Switch, Dimmer, Device Plate, Weatherproof Enclosure, Stand Alone Occupancy and Vacancy Sensor, Perimeter Raceway, Floor Box, In Floor Raceway or One Floor Raceway, Recessed Floor Box for Slab on Grade, Flush Poke-Through Assembly, Service Pole, Cord Reel, and Cord Drop

C. RECEPTACLE

1. Requirements for receptacle
 - a. Submittal
 - b. Manufactured by Cooper Wiring Devices, Hubbell, Leviton, or Pass and Seymour
 - c. Color gray typically (adjust per existing), red for life safety, brown for standby, orange for isolated ground, black for surge protective device, blue for automatic receptacle control
 - d. Premium specification grade, 20 ampere minimum
 - e. No integral USB ports
 - f. Tamper resistant type
 - g. Mount vertically 18 inches above finished floor or grade typically (adjust to nearest block course)
 - h. Mounted horizontal 4 inches above counter backsplash
 - i. Installed with ground connection up where vertical and ground connection to the left for horizontal
 - j. Special devices to match load
 - k. Weather resistant duplex mounted on roof, connected dedicated circuit from 208Y/120V panelboard (not mechanical equipment), in weatherproof enclosure (weatherproof while in use cover)
 - l. Energy code automatically controlled receptacles with labeling:
 1. General: Wall mounted receptacles to be double duplex outlets with one (1) duplex continuously powered and other than blue, and one (1) duplex controlled as outlined with contactors located in electrical rooms
 2. Individual rooms, controlled via occupancy sensor power pack
 3. Individual rooms with existing wireless lighting control via contactor(s) interfaced with building automation system
 4. Large open areas with modular furniture control shared neutral circuits with contactor(s) interfaced with building automation system and wall mounted 2 hour override timer switch (leaving the dedicated neutral circuit for computer CPU's only continuously powered)
 5. All wall mounted monitors, displays, and projectors controlled via dedicated contactor(s) interfaced with building automation system

D. SWITCH

1. Requirements for switch
 - a. Submittal
 - b. Manufactured by Cooper Wiring Devices, Hubbell, Leviton, or Pass and Seymour
 - c. Color gray typically (adjust per existing), red for life safety, clear with red pilot light (pilot light load on), clear with white illuminated handle (pilot light load off)

- d. Premium specification grade, 20 ampere minimum
 - e. Mounted within 18 inches of the door jamb
 - f. Mounted 46 inches to center above finished floor
 - g. Pilot light load on for control of equipment
 - h. Pilot light load off in mechanical and electrical rooms
- E. DIMMER
- 1. Requirements for dimmer
 - a. Submittal
 - b. Compatible with LED luminaire being controlled
 - c. Gray color (adjust per existing)
 - d. Pushbuttons to raise and lower with separate on/off switch
 - e. Spare devices of 10 percent with a minimum of two (2)
 - f. Other requirements refer to switch
- F. DEVICE PLATE
- 1. Requirements for device plate
 - a. Submittal
 - b. Manufactured by Cooper Wiring Devices, Hubbell, Leviton, or Pass and Seymour
 - c. Stainless steel
 - d. Panelboard and circuit number labeled on inside with permanent marker and outside with Kroy type labeling
- G. WEATHERPROOF ENCLOSURE
- 1. Requirements for weatherproof enclosure
 - a. Submittal
 - b. Manufactured by Hubbell, Pass and Seymour, Taymac, Thomas and Betts, or Raco
 - c. NEMA 3R rating while in use
 - d. Metallic die cast alloy 360 copper-free aluminum baked lacquer finish
 - e. For devices mounted on the roof and other locations subject to water from above
 - f. Panelboard and circuit number labeled on inside with Kroy type labeling
- H. STAND ALONE OCCUPANCY AND VACANCY SENSOR
- 1. Requirements for stand alone occupancy and vacancy sensor
 - a. Submittal
 - b. Manufactured by Acuity or Wattstopper
 - c. Passive infrared and ultrasonic or audio sensing dual technology products
 - d. Appropriate for the location and application
 - e. Manual on for vacancy sensors
 - f. Auxiliary contacts
 - g. Daylight sensing
 - h. Spare devices of 10 percent with a minimum of two (2)
 - i. Wall box type vacancy sensors in small rooms
 - j. Ceiling mounted most areas
 - k. All, except egress and exit lighting, controlled by occupancy and vacancy sensors
 - l. Ceiling devices connected ahead of wall switch manual control with maintenance switch ahead of sensor
 - m. Auxiliary contacts for interface with building automation system and automatically connected receptacles

I. PERIMETER RACEWAY

1. Requirements for perimeter raceway
 - a. Submittal
 - b. Multi-channel steel finished in gray suitable for field repainting
 - c. Duplex device spacing indicated on drawings
 - d. Includes communication section with devices indicated on drawings
 - e. Plugmold multi-outlet assemblies not allowed
 - f. Continuous lengths
 - g. Two (2) 3/4 inch conduits from communication section per end stubbed to above accessible ceiling
 - h. Maximum of 4 duplex receptacles per circuit wired alternately in long lengths

J. FLOOR BOX

1. Requirements for floor box
 - a. Not allowed

K. IN FLOOR RACEWAY OR ON FLOOR RACEWAY

1. Requirements for in floor raceway or on floor raceway
 - a. Not allowed

L. RECESSED FLOOR BOX FOR SLAB ON GRADE

1. Requirements for recessed floor box for slab on grade
 - a. Submittal
 - b. Cast iron with number of gangs indicated on drawings
 - c. Brushed aluminum cover with cord training openings
 - d. No plastic trim pieces allowed
 - e. Devices as indicated
 - f. Minimum 1-1/4 inch conduit from communication section per 4 devices stubbed to above accessible ceiling of the same floor level
 - g. Coordinate locations with floor construction

M. RECESSED POKE-THROUGH ASSEMBLY

1. Requirements for recessed poke-through assembly
 - a. Submittal
 - b. Fire rated assembly
 - c. Flush aluminum flange
 - d. Devices as indicated and recessed under a hinged brushed aluminum cover with cord training opening
 - e. No plastic trim pieces allowed
 - f. Minimum of 3/4 inch conduit from communication devices stubbed to above accessible ceiling of the floor level below
 - g. Gray or black

N. SERVICE POLE

1. Requirements for service pole
 - a. Submittal
 - b. Steel with gray or ivory finish
 - c. Height to 6 inches above ceiling
 - d. Devices as indicated
 - e. Connections above ceiling

O. CORD REEL

1. Requirements for cord reel
 - a. Submittal
 - b. Manufactured by Molex/Woodhead
 - c. Two (2) 20 ampere, GFCI protected receptacles connected with twist lock receptacle at ceiling
 - d. Strain relief at receptacle box
 - e. Standard duty Model 998L Series in classrooms
 - f. Industrial duty Model 9383 Series in shops
 - g. Where mounted in accessible ceiling areas use brushed stainless steel plate ceiling tile

P. CORD DROP

1. Requirements for cord drop
 - a. Submittal
 - b. SO cord with two (2) 20 ampere, GFCI protected receptacles connected with twist lock receptacle at ceiling
 - c. Strain relief at receptacle box and connection at ceiling
 - d. Where mounted in accessible ceiling areas use brushed stainless steel plate ceiling tile

END OF SECTION

SECTION 26 28 16
ENCLOSED SWITCH

PART 1 – GENERAL

A. SUBJECT TO CHANGE

1. These standards are subject to change. Verify that the latest are being used. Product manufacturers listed is the basis of design or equivalent unless noted otherwise.

B. SUMMARY – SECTION INCLUDES

1. Enclosed Switch

C. ENCLOSED SWITCH

1. Requirements for enclosed switch
 - a. Submittal
 - b. Manufactured by ABB, Siemens, and Square D
 - c. Heavy duty, 100 percent duty rated
 - d. NEMA 1 enclosures typically, NEMA 3R for wet or exterior locations, or NEMA 4X in kitchens
 - e. Open auxiliary contacts when switch is open for VFD interface

D. ELEVATOR DISCONNECT

1. Requirements for elevator disconnect
 - a. Submittal
 - b. Manufactured by Bussmann
 - c. NEMA 4 enclosure
 - d. Type LPJ fuses
 - e. Shunt-trip power monitor relay
 - f. Pilot light
 - g. Open auxiliary contacts when switch is open
 - h. Locate within 18 inches of machine room door jamb
 - i. Monitor shunt-trip power relay and auxiliary contacts with fire alarm

END OF SECTION

PAGE INTENTIONALLY BLANK

SECTION 26 29 13

MOTOR STARTER

PART 1 – GENERAL

A. SUBJECT TO CHANGE

1. These standards are subject to change. Verify that the latest are being used. Product manufacturers listed is the basis of design or equivalent unless noted otherwise.

B. SUMMARY – SECTION INCLUDES

1. Motor Starter

C. MAGNETIC MOTOR STARTER

1. Requirements for magnet motor starter
 - a. Supplied by others
 - b. Installed by electrical contractor
 - c. Labeled with load controlled and panelboard and circuit

D. MANUAL MOTOR STARTER

1. Requirements for manual motor starter
 - a. Submittal
 - b. Manufactured by Allen Bradley, General Electric, or Siemens
 - c. Thermal overloads (where indicated) matched to load controlled
 - d. Pilot light
 - e. Mounted adjacent to equipment
 - f. Labeled with load protected, panelboard, and circuit

END OF SECTION

PAGE INTENTIONALLY BLANK

SECTION 26 32 13

ENGINE GENERATOR SYSTEM

PART 1 – GENERAL

A. SUBJECT TO CHANGE

1. These standards are subject to change. Verify that the latest are being used. Product manufacturers listed is the basis of design or equivalent unless noted otherwise.

B. SUMMARY – SECTION INCLUDES

1. Engine Generator System

C. ENGINE GENERATOR SYSTEM

1. Requirements for engine generator system
 - a. Submittal
 - b. Manufactured by Caterpillar, Cummins/Onan, Generac
 - c. Natural gas engine with submittal of Department of Regulatory Agencies “NATURAL GAS AS AN ALTERNATE FUEL SOURCE” document
 - d. 105 degree Celsius rated windings
 - e. Neutral bonded to housing
 - f. Sound attenuated weather resistant enclosure
 - g. Rodent resistant enclosure
 - h. Site rated
 - i. Starting aids such as battery warming pads, block heater, etc.
 - j. Permanent magnet type alternator
 - k. Battery charger at generator
 - l. Digital remote annunciator
 - m. Located on concrete pad on exterior of building
 - n. Overcurrent coordinated
 - o. EPO located on building near engine generator
 - p. Factory start-up
 - q. 4 hour load bank testing with single step
 - r. Training
 - s. Remote annunciator located in building engineer’s office
 - t. Remote annunciator NFPA 110 includes alarms, sounder activation (lamp color-flashing where indicated) and other components: Overspeed, sound (red), Low Oil Pressure, sound (red), Pre-Low Oil Pressure, sound (red), High Engine Temp, sound (red), Pre-High Engine Temp, sound (amber), Low Coolant Temp, sound (red), Failure to Start, sound (red), Weak Battery, sound (red), Low Battery Voltage, sound (red), High Battery Voltage, sound (amber), Genset Running (amber), Not In Auto, sound (red-flashing), Check Genset (amber), Low Fuel Level, sound (red), Low Coolant Level, sound (amber), Charger AC Failure, sound (amber), Genset Supplying Load (amber), Customer Fault 1 (red), Customer Fault 2 (amber), Customer Fault 3 (red), Network Status Lamp (red), silence/lamp test button, and horn.

END OF SECTION

PAGE INTENTIONALLY BLANK

SECTION 26 36 00
TRANSFER SWITCH

PART 1 – GENERAL

A. SUBJECT TO CHANGE

1. These standards are subject to change. Verify that the latest are being used. Product manufacturers listed is the basis of design or equivalent unless noted otherwise.

B. SUMMARY – SECTION INCLUDES

1. Transfer Switch

C. TRANSFER SWITCH

1. Requirements for transfer switch
 - a. Submittal
 - b. Manufactured by ASCO, Caterpillar, Cummins/Onan, ABB/Zenith, Generac
 - c. 4 pole
 - d. 3 per position auxiliary contracts
 - e. Testing with engine generator
 - f. Touch screen on cover to adjust user settings

END OF SECTION

PAGE INTENTIONALLY BLANK

SECTION 26 43 13

SURGE PROTECTIVE DEVICE

PART 1 – GENERAL

A. SUBJECT TO CHANGE

1. These standards are subject to change. Verify that the latest are being used. Product manufacturers listed is the basis of design or equivalent unless noted otherwise.

B. SUMMARY – SECTION INCLUDES

1. Surge Protective Device

C. SURGE PROTECTIVE DEVICE

1. Requirements for surge protective device
 - a. Submittal
 - b. Main service device Current Technology SL3-300 (no equivalent) disconnect, surge counter, indicator lights, test port, and 20 year warranty
 - c. Generator distribution surge protective device ABB OVRHT3C50 or equivalent
 - d. Receptacle device from manufacturer of receptacles
 - e. Main service device tapped to bus with 4#2,1#2G,1-1/2”C maximum of 10 feet cable length with minimal bends
 - f. Generator distribution surge protective device connected to 20 ampere, 3 pole circuit breaker in the first panelboard downstream of the automatic transfer switch mounted adjacent to panelboard protected

END OF SECTION

PAGE INTENTIONALLY BLANK

SECTION 26 50 00

LIGHTING

PART 1 – GENERAL

A. SUBJECT TO CHANGE

1. These standards are subject to change. Verify that the latest are being used. Product manufacturers listed is the basis of design or equivalent unless noted otherwise.

B. SUMMARY – SECTION INCLUDES

1. Lighting

C. LIGHTING

1. Requirements for lighting
 - a. Submittal
 - b. Manufactured by well-known manufacturer, all manufacturers approved by CCSD
 - c. Manufactured by those indicated on luminaire schedule
 - d. LED light sources with minimum 5 year material and labor warranty
 - e. 4000K color temperature
 - f. 80 CRI for most uses with 90 CRI in art rooms and dressing rooms
 - g. Limited glare
 - h. Dimmable
 - i. Exit signs cast aluminum with green letters
 - j. Pole mounted on pole base designed by structural engineer
 - k. Exterior mounting heights and light trespass to meet local lighting ordinance with a backlight rating that minimizes light trespass and glare, an up light rating of 0, and a maximum glare rating of 2
 - l. Spare drivers and LED boards of 10 percent with a minimum of two (2) per luminaire type
 - m. Spare UL 924 relays of 10 percent of installed components with minimum of two (2)
 - n. Interior lighting, except egress and exit lighting, controlled by occupancy and vacancy sensors
 - o. All exterior building mounted luminaires connected to generator
 - p. Egress luminaires indicated with an adjacent red sticker
 - q. Interior luminaires in most rooms, except storage, and equipment, to have dimming
 - r. Instructional spaces with generator powered luminaires to be controlled with other lighting via UL 924 relay
 - s. Manual lighting control in all interior locations
 - t. Exterior lighting controlled by building automation system via contactors with manual over-ride switch labeled
 - u. Illumination levels and requirements to comply with Code of Colorado Regulations for instructional and general use areas
 - v. Illumination levels for kitchens to be minimum of 50 footcandles
 - w. Illumination for elevator equipment rooms and pits to meet the requirements of ANSI
 - x. Interior lighting maximum of 3 to 1 maximum to minimum
 - y. Egress lighting per Code with no greater than 40 to 1 maximum to minimum
 - z. Illumination levels for parking and exterior walkway areas to be minimum of 0.2 footcandles, 20 to 1 maximum to minimum, and 4 to 1 average to minimum
 - aa. Illumination levels for building entrances 2 footcandle average, and maximum of 5 footcandles
 - bb. Pass COMcheck
 - cc. Interior daylight and occupancy control per energy code

- dd. Energy code automatically time controlled lighting contactors located in electrical rooms, contactor(s) interfaced with building automation system, and wall mounted maximum two (2) hour override switches for interior lighting
- ee. Exterior area lighting with motion controlled dimming per energy code, use the maximum amount of allowed energy so that at 50 percent power the surveillance cameras are effective

END OF SECTION