

BID ADDENDUM NO. 2

OWNER: EDGEMONT UNION FREE SCHOOL DISTRICT

PROJECT NAME: ADMINISTRATION BUILDING ADDITION,
SITE IMPROVEMENTS & RELATED WORK

This Addendum is hereby included in and made a part of the Contract Documents, dated February 28, 2025 whether or not attached thereto.

All requirements of the original project specifications and drawings shall remain in force except as amended by this addendum.

DATE: March 18, 2025

This addendum consists of two (2) pages plus revised Bid Form Contract #1, Bid Form Contract #2, Bid Form Contract #3 and Bid Form Contract #4, Sketch SK-E1.0, revised drawing E002 and E120.

THE FOLLOWING ARE MODIFICATIONS, CLARIFICATIONS, DELETIONS OR ADDITIONS TO THE SPECIFICATIONS:

00 4100 – BID FORM CONTRACT #1 GENERAL CONSTRUCTION

DELETE in its entirety and **REPLACE** with revised attached section Bid Form Contract #1.

00 4110 – BID FORM CONTRACT #2 PLUMBING

DELETE in its entirety and **REPLACE** with revised attached section Bid Form Contract #2.

00 4120 – BID FORM CONTRACT #3 MECHANICAL

DELETE in its entirety and **REPLACE** with revised attached section Bid Form Contract #3.

00 4130 – BID FORM CONTRACT #4 ELECTRICAL

DELETE in its entirety and **REPLACE** with revised attached section Bid Form Contract #4.

01 2100 – ALLOWANCES

01 2100-1.7 ADD”

8. GC- 1 Removal of Trench Rock:
 - a. Description: Removal of trench rock off site and backfill resultant void.
Unit of Measurement: Cubic Yard
Quantity: One hundred cubic yards of trench rock including backfilling.
One Hundred cubic yards @ _\$_____ per each yard:
_____ (\$ _____) DOLLARS
9. GC-2 Removal of Mass Rock:
 - a. Description: Removal of mass rock, backfill resultant void and disposed off site.
Unit of Measurement: Cubic Yard
Quantity: Three hundred cubic yards of mass rock including backfilling.
Three hundred cubic yards @ _\$_____ per each yard:”.

03 3000 – CAST-IN-PLACE CONCRETE

03 3000-7, 2.5 ADD “Q. Underslab Vapor Retarder:

1. Sheet Material: ASTM E1745, Class A; stated by manufacturer as suitable for installation in contact with soil or granular fill under concrete slabs. Single-ply polyethylene is prohibited.
2. Installation: Comply with ASTM E1643.
3. Accessory Products: Vapor retarder manufacturer's recommended tape, adhesive, mastic, prefabricated boots, etc., for sealing seams and penetrations.
4. Products:
 - a. "Griffolyn T-65G" by Reef Industries Inc, three-ply nylon, or polyester-cord-reinforced high-density polyethylene sheet; laminated to a nonwoven geotextile fabric, 30 mils thick."

THE FOLLOWING ARE MODIFICATIONS, CLARIFICATIONS, DELETIONS OR ADDITIONS TO THE DRAWINGS:

DRAWING E001 – ELECTRICAL NOTES, LEGEND, DRAWING SCHEDULE, AND KEY PLAN
ADD Key Plan as shown on Sketch SK-E1.0 attached to this addendum.

DRAWING E002 – ELECTRICAL LIGHTING FIXTURE SCHEDULE, LIGHTING CONTROL SCHEDULE, & LIGHTING CONTROL DETAILS
REVISE Lighting Fixture Schedule as shown on revised drawing attached to this addendum.

DRAWING AD E120 – LOWER LEVEL ELECTRICAL LIGHTING PLAN
REVISE exterior light fixtures as shown on revised drawing attached to this addendum.

END OF SED ADDENDUM NO. 2

The following attachments are being provided for informational purposes:

Bidder RFI Responses (In the event of a discrepancy between these responses and the contract documents, the contract documents shall prevail unless modified by addendum.)

Bid RFI-#002 dated 3/13/2025 (1 page).

Bid RFI-#003 undated (1 page).

Bid RFI-#004 dated 3/17/2025 (1 page).

**SECTION 00 4100
BID FORM CONTRACT #1 GENERAL CONSTRUCTION**

THE PROJECT AND THE PARTIES

TO:

Edgemont School District
300 White Oak Lane:
Scarsdale, NY 10583

FOR:

Administration Building Cafeteria Addition
Edgemont Jr./Sr. High School
300 White Oak Lane
Scarsdale, NY

DATE: _____ (Bidder to enter date)

All information must be typewritten. Handwritten Bid Form will be rejected.

SUBMITTED BY: _____

Bidder's Full Name _____

Address _____

City, State, Zip _____

Contact Individual _____

Telephone No. _____ E-mail: _____

1.1 OFFER

A. Having examined the Place of The Work and all matters referred to in the Bidding Requirements and the Contract Documents prepared by Fuller and D'Angelo, P.C. for the Administration Building & Building A Additions, Site Improvements & Related Work, we, the undersigned, hereby offer to enter into a Contract to perform Contract No.1 General Construction Work for the Sum of:

1. **BASE BID**

a. The Base Bid of this Proposal for all work required by the Contract Documents for Contract No.1 General Construction for the Administration Building Additions, Site Improvements & Related Work is as follows:
_____ (\$ _____) DOLLARS

b. **TOTAL ALLOWANCES**

a) The Total Allowance as indicated in Section 01 2100 - Allowances is as follows:
_____ \$ _____ DOLLARS

Note: Attach Section 01 2100 - Allowances itemized contingency list to bid proposal.

c. **TOTAL BASE BID**

The Total Base Bid of this Proposal for all work required by the Contract Documents for Contract No.1 General Construction for the Administration Building Additions, Site Improvements & Related Work is as follows:

_____ (\$ _____) DOLLARS

(The Total Base Bid is sum of 1.1.A.1.a and 1.1.A.1.b).

B. The undersigned further understands and agrees that he is to furnish and provide all the necessary material, machinery, plant, implements, tools, labor, services, skill and other items of whatever nature required, and to do and perform all the work necessary under the Contract, to complete the work in accordance with the drawings and specifications and any addenda thereto, and to accept in full

FULLER AND D'ANGELO, P.C.
ARCHITECTS AND PLANNERS

Edgemont School District
Administration Building Cafeteria Addition
Site Improvements & Related Work
BID FORM CONTRACT #1 GENERAL CONSTRUCTION

compensation therefore the amount of the Total Base Bid stated, modified by such additive- or deductive alternatives, if any as are accepted by the Owner.

- C. We have included the required Performance and Payment bonds **costs** in the Bid Amount.

1.2 ACCEPTANCE

- A. This offer shall be open to acceptance and is irrevocable for forty-five (45) days from the bid closing date during which time the Owner has the right to enter into a contract, and the bid securities of the three (3) lowest responsible bidders shall be held until the executive of the Contract. Once the bid proposal has been submitted in the sealed envelope, there shall be no alterations or amendments; external markings or separate supplementary information shall, in no way, affect the sealed bid information. The contract will be awarded to the lowest responsible bidder meeting the specifications and furnishing the required security.
- B. Upon award by the the Edgemont School District within the time period stated above, we will:
1. Execute the Agreement within ten (10) days of receipt of Notice of Award or five (5)days following receipt of Contract, whichever is later.
 2. Furnish the required Performance and Payment bonds within ten (10) days of receipt of Notice of Award or with the executed Contract.
- C. If this contract is accepted within the time stated, and we fail to commence the Work or we fail to provide the required Bonds, the security deposit shall be forfeited as damages to Edgemont School District by reason of our failure, limited in amount to the lesser of the face value of the security deposit or the difference between this bid and the bid upon which a Contract is signed.
- D. In the event our bid is not accepted within the time stated above, the required security deposit shall be returned to the undersigned, in accordance with the provisions of the Instructions to Bidders; unless a mutually satisfactory arrangement is made for its retention and validity for an extended period of time.

1.3 REJECTION OF BIDS

- A. The Owner reserves the right to reject any or all proposals and to waive non-material variances in bid submissions as it deems in the best interests of the Owner.

1.4 CONTRACT TIME

- A. If this Bid is accepted, we will:
1. Complete all the work covered by this Proposal with a commencement date of NO EARLIER THAN Award of Contract by Owner. Work shall be phased as indicated in 01 1000 Summary of Contract. Failure to complete each phase of work by dates indicated will result in liquidated damages as stated in the AIA 232- 2017 General Conditions of the Contract .

1.5 CHANGES TO THE WORK

- A. Refer to Article 8 of the General Conditions .

1.6 ADDENDA

- A. The following Addenda have been received. The modifications to the Bid Documents noted below have been considered and all costs are included in the Bid Sum.
1. Addendum # _____ Dated _____.
 2. Addendum # _____ Dated _____.
 3. Addendum # _____ Dated _____.
 4. Addendum # _____ Dated _____.

1.7 BID FORM SUPPLEMENTS

- A. Refer to Section 00 4301 - Bid Form Supplements.

1.8 BIDDER'S FURTHER AFFIRMATION AND DECLARATION

- A. The above name bidder and should this bid be a joint bid each party thereto, further affirm and declares:

FULLER AND D'ANGELO, P.C.
ARCHITECTS AND PLANNERS

Edgemont School District
Administration Building Cafeteria Addition
Site Improvements & Related Work
BID FORM CONTRACT #1 GENERAL CONSTRUCTION

1. That said bidder is of lawful age and the only one interested in this bid; and that no other person, firm or corporation, except those herein above named, has any interest in this bid or in the contract proposed to be entered into.
2. That this bid is made without any understanding, agreement or connection with any other person, firm, or corporation making a bid for the same work, and is in all respects fair and without collusion or fraud.
3. That said bidder is not in arrears to the Edgemont School District upon debt or contract, and is not a defaulter, as surety or otherwise upon any obligation to the said Edgemont School District
4. That no member of the Edgemont School District or any officer or employee of the Edgemont School District or person whose salary is payable in whole or in part from the Edgemont School District treasury, or the spouse of any foregoing is or shall be or become interested, directly or indirectly, as a contracting party, partner, stockholder, surety or otherwise, in this bid, or in the performance of the Contract, or in the supplies, materials or equipment and work or labor to which it relates, or in any portion of the profits thereof.
5. That he/she has carefully examined the site of the work and that, from his/her own investigations, he/she has satisfied him/herself as to the nature and location of the work, and character, quality and quantity of materials, and all difficulties likely to be encountered, the kind and extent of equipment and other facilities needed for the performance of the work, the general and local conditions, and all other items which may, in any way, affect the work or its performance.
6. That if a corporation, this bid or proposal containing the Non-Collusive Binding Certification and the foregoing Affirmation and Declaration has been authorized by the Board of Directors of such Corporation, which authorization includes the signing and submission of this bid or proposal and the inclusion therein of the said Certificate of Non-Collusion and Affirmation and Declaration as the Act and Deed of the Corporation.

1.9 BID FORM SIGNATURE(S)

The Corporate Seal of

(Bidder - print the full name of your firm)

was hereunto affixed in the presence of:

(Authorized signing officer, Title)

(Seal)

(Authorized signing officer, Title)

If the Bid is a joint venture or partnership, add additional forms of execution for each member of the joint venture in the appropriate form or forms as above.

Subscribed and sworn before me this day of ____ 202 ____

Notary Public: _____

My Commission Expire: _____

END OF BID FORM

**SECTION 00 4110
BID FORM CONTRACT #2 PLUMBING**

THE PROJECT AND THE PARTIES

TO:

Edgemont School District
300 White Oak Lane:
Scarsdale, NY 10583

FOR:

Administration Building Cafeteria Addition
Edgemont Jr./Sr. High School
300 White Oak Lane
Scarsdale, NY

DATE: _____ (Bidder to enter date)

All information must be typewritten. Handwritten Bid Form will be rejected.

SUBMITTED BY: _____

Bidder's Full Name _____

Address _____

City, State, Zip _____

Contact Individual _____

Telephone No. _____ E-mail: _____

1.1 OFFER

A. Having examined the Place of The Work and all matters referred to in the Bidding Requirements and the Contract Documents prepared by Fuller and D'Angelo, P.C. for the Administration Building & Building A Additions, Site Improvements & Related Work, we, the undersigned, hereby offer to enter into a Contract to perform Contract No. 2 Work for the Sum of:

1. **BASE BID:**

a. The Base Bid of this Proposal for all work required by the Contract Documents for Contract No. 2 Plumbing at the Administration Building Additions, Site Improvements & Related Work is as follows:
_____ (\$ _____) DOLLARS

b. **TOTAL ALLOWANCES**

a) The Total Unit Cost Allowance as indicated in Section 01 2100 - Allowances is as follows:
Eight Thousand _____ (\$8,000.00) DOLLARS

2. **TOTAL BASE BID**

a. The Total Base Bid of this Proposal for all work required by the Contract Documents for Contract No. 2 Plumbing and Related Work work for the Administration Building Additions, Site Improvements & Related Work is as follows:
_____ (\$ _____) DOLLARS

B. The undersigned further understands and agrees that he is to furnish and provide all the necessary material, machinery, plant, implements, tools, labor, services, skill and other items of whatever nature required, and to do and perform all the work necessary under the Contract, to complete the work in accordance with the drawings and specifications and any addenda thereto, and to accept in full compensation therefore the amount of the Total Base Bid stated, modified by such additive- or deductive alternatives, if any as are accepted by the Owner.

FULLER AND D'ANGELO, P.C.
ARCHITECTS AND PLANNERS

- C. All Allowances described in Section - 01 2100 - Allowances are included in the Total Bid Sum.

1.2 ACCEPTANCE

- A. This offer shall be open to acceptance and is irrevocable for forty-five (45) days from the bid closing date, during which time the Owner has the right to enter into a contract, and the bid securities of the three (3) lowest responsible bidders shall be held until the execution of the Contract. Once the bid proposal has been submitted in the sealed envelope, there shall be no alterations or amendments; external markings or separate supplementary information shall, in no way, affect the sealed bid information. The contract will be awarded to the lowest responsible bidder meeting the specifications and furnishing the required security.
- B. Upon award by the Edgemont School District within the time period stated above, we will:
1. Execute the Agreement within ten (10) days of receipt of Notice of Award or five (5) days following receipt of Contract, whichever is later.
 2. Furnish the required Performance and Payment bonds within ten (10) days of receipt of Notice of Award or with the executed Contract.
- C. If this contract is awarded to us and we fail to commence the Work or we fail to provide the required Bonds, the security deposit shall be forfeited as damages to Edgemont School District by reason of our failure, limited in amount to the lesser of the face value of the security deposit or the difference between this bid and the bid upon which a Contract is signed.
- D. In the event our bid is not accepted within the time stated above, the required security deposit shall be returned to the undersigned, in accordance with the provisions of the Instructions to Bidders; unless a mutually satisfactory arrangement is made for its retention and validity for an extended period of time.

1.3 REJECTION OF BIDS

- A. The Owner reserves the right to reject any or all proposals and to waive non-material variances in bid submissions as it deems in the best interests of the Owner.

1.4 CONTRACT TIME

- A. If this Bid is accepted, we will:
1. Complete all the work covered by this Proposal with a commencement date of NO EARLIER THAN Award of Contract by Owner. Work shall be phased as indicated in 01 1010 Milestone Schedule. Failure to complete each phase of work by dates indicated will result in liquidated damages as stated in the General Conditions.

1.5 CHANGES TO THE WORK

- A. Refer to Article 8 of the General Conditions .

1.6 ADDENDA

- A. The following Addenda have been received. The modifications to the Bid Documents noted below have been considered and all costs are included in the Bid Sum.
1. Addendum # _____ Dated _____.
 2. Addendum # _____ Dated _____.
 3. Addendum # _____ Dated _____.
 4. Addendum # _____ Dated _____.

1.7 BID FORM SUPPLEMENTS

- A. Refer to Section 00 4301 - Bid Form Supplements.

1.8 BIDDER'S FURTHER AFFIRMATION AND DECLARATION

- A. The above named bidder and should this bid be a joint bid each party thereto, further affirm and declares:
1. That said bidder is of lawful age and the only one interested in this bid; and that no other person, firm or corporation, except those herein above named, has any interest in this bid or in the contract proposed to be entered into.

Edgemont School District
Administration Building Cafeteria Addition
Site Improvements & Related Work
BID FORM CONTRACT #2 PLUMBING

2. That this bid is made without any understanding, agreement or connection with any other person, firm, or corporation making a bid for the same work, and is in all respects fair and without collusion or fraud.
3. That said bidder is not in arrears to the Edgemont School District upon debt or contract, and is not a defaulter, as surety or otherwise upon any obligation to the said Edgemont School District
4. That no member of the Edgemont School District or any officer or employee of the Edgemont School District or person whose salary is payable in whole or in part from the Edgemont School District treasury, or the spouse of any foregoing is or shall be or become interested, directly or indirectly, as a contracting party, partner, stockholder, surety or otherwise, in this bid, or in the performance of the Contract, or in the supplies, materials or equipment and work or labor to which it relates, or in any portion of the profits thereof.
5. That he/she has carefully examined the site of the work and that, from his/her own investigations, he/she has satisfied him/herself as to the nature and location of the work, and character, quality and quantity of materials, and all difficulties likely to be encountered, the kind and extent of equipment and other facilities needed for the performance of the work, the general and local conditions, and all other items which may, in any way, affect the work or its performance.
6. That if a corporation, this bid or proposal containing the Non-Collusive Binding Certification and the foregoing Affirmation and Declaration has been authorized by the Board of Directors of such Corporation, which authorization includes the signing and submission of this bid or proposal and the inclusion therein of the said Certificate of Non-Collusion and Affirmation and Declaration as the Act and Deed of the Corporation.

1.9 BID FORM SIGNATURE(S)

The Corporate Seal of

(Bidder - print the full name of your firm)

was hereunto affixed in the presence of:

(Authorized signing officer, Title)

(Seal)

(Authorized signing officer, Title)

If the Bid is a joint venture or partnership, add additional forms of execution for each member of the joint venture in the appropriate form or forms as above.

Subscribed and sworn before me this day of ____ 202* ____

Notary Public: _____

My Commission Expire: _____

END OF BID FORM

SECTION 00 4120
BID FORM CONTRACT #3 MECHANICAL

THE PROJECT AND THE PARTIES

TO:

Edgemont School District
300 White Oak Lane:
Scarsdale, NY 10583

FOR:

Administration Building Cafeteria Addition
Edgemont Jr./Sr. High School
300 White Oak Lane
Scarsdale, NY

DATE: _____ (Bidder to enter date)

All information must be typewritten. Handwritten Bid Form will be rejected.

SUBMITTED BY: _____

Bidder's Full Name _____

Address _____

City, State, Zip _____

Contact Individual _____

Telephone No. _____ E-mail: _____

1.1 OFFER

A. Having examined the Place of The Work and all matters referred to in the Bidding Requirements and the Contract Documents prepared by Fuller and D'Angelo, P.C. for the Administration Building Additions, Site Improvements & Related Work, we, the undersigned, hereby offer to enter into a Contract to perform Contract No. 3 Mechanical Work for the Sum of:

1. **BASE BID**

a. The Base Bid of this Proposal for all work required by the Contract Documents for Contract No. 3 Mechanical for the Administration Building Additions, Site Improvements & Related Work is as follows:
_____ (\$ _____) DOLLARS

b. **TOTAL ALLOWANCES**

a) The Total Unit Cost Allowance as indicated in Section 01 2100 - Allowances is as follows:
Twenty Eight Thousand _____ (\$28,000.00) DOLLARS

2. **TOTAL BASE BID**

a. The Total Base Bid of this Proposal for all work required by the Contract Documents for Contract No. 3 Mechanical and Related Work work for the Administration Building Additions, Site Improvements & Related Work is as follows:
_____ (\$ _____) DOLLARS

(The Total Base Bid is sum of 1.1.A.1.a and 1.1.A.1.b).

a. Note: Attach Section 01 2100 - Allowances itemized contingency list to bid proposal.

B. The undersigned further understands and agrees that he is to furnish and provide all the necessary material, machinery, plant, implements, tools, labor, services, skill and other items of whatever nature required, and to do and perform all the work necessary under the Contract, to complete the work in accordance with the drawings and specifications and any addenda thereto, and to accept in full

FULLER AND D'ANGELO, P.C.
ARCHITECTS AND PLANNERS

compensation therefore the amount of the Total Base Bid stated, modified by such additive- or deductive alternatives, if any as are accepted by the Owner.

- C. All Allowances described in Section - 01 2100 - Allowances are included in the Total Bid Sum.

1.2 ACCEPTANCE

- A. This offer shall be open to acceptance and is irrevocable for forty-five (45) days from the bid closing date during which time the Owner has the right to enter into a contract, and the bid securities of the three (3) lowest responsible bidders shall be held until the execution of the Contract. Once the bid proposal has been submitted in the sealed envelope, there shall be no alterations or amendments; external markings or separate supplementary information shall, in no way, affect the sealed bid information. The contract will be awarded to the lowest responsible bidder meeting the specifications and furnishing the required security.
- B. Upon award by the Edgemont School District within the time period stated above, we will:
1. Execute the Agreement within ten (10) days of receipt of Notice of Award or five (5) days following receipt of Contract, whichever is later.
 2. Furnish the required Performance and Payment bonds within ten (10) days of receipt of Notice of Award or with the executed Contract.
- C. If this contract is awarded to us and we fail to commence the Work or we fail to provide the required Bonds, the security deposit shall be forfeited as damages to Edgemont School District by reason of our failure, limited in amount to the lesser of the face value of the security deposit or the difference between this bid and the bid upon which a Contract is signed.
- D. In the event our bid is not accepted within the time stated above, the required security deposit shall be returned to the undersigned, in accordance with the provisions of the Instructions to Bidders; unless a mutually satisfactory arrangement is made for its retention and validity for an extended period of time.

1.3 REJECTION OF BIDS

- A. The Owner reserves the right to reject any or all proposals and to waive non-material variances in bid submissions as it deems in the best interests of the Owner.

1.4 CONTRACT TIME

- A. If this Bid is accepted, we will:
1. Complete all the work covered by this Proposal with a commencement date of NO EARLIER THAN Award of Contract by Owner. Work shall be performed as indicated in 01 1000 Summary of Contract. Failure to complete each phase of work by dates indicated will result in liquidated damages as stated in the AIA 232- 2017 General Conditions of the Contract

1.5 CHANGES TO THE WORK

- A. Refer to Article 8 of the General Conditions

1.6 ADDENDA

- A. The following Addenda have been received. The modifications to the Bid Documents noted below have been considered and all costs are included in the Bid Sum.
1. Addendum # _____ Dated _____.
 2. Addendum # _____ Dated _____.
 3. Addendum # _____ Dated _____.
 4. Addendum # _____ Dated _____.

1.7 BID FORM SUPPLEMENTS

- A. Refer to Section 00 4301 - Bid Form Supplements.

1.8 BIDDER'S FURTHER AFFIRMATION AND DECLARATION

- A. The above name bidder and should this bid be a joint bid each party thereto, further affirm and declares:

Edgemont School District
Administration Building Cafeteria Addition
Site Improvements & Related Work
BID FORM CONTRACT #3 MECHANICAL

1. That said bidder is of lawful age and the only one interested in this bid; and that no other person, firm or corporation, except those herein above named, has any interest in this bid or in the contract proposed to be entered into.
2. That this bid is made without any understanding, agreement or connection with any other person, firm, or corporation making a bid for the same work, and is in all respects fair and without collusion or fraud.
3. That said bidder is not in arrears to the Edgemont School District upon debt or contract, and is not a defaulter, as surety or otherwise upon any obligation to the said Edgemont School District
4. That no member of the Edgemont School District or any officer or employee of the Edgemont School District or person whose salary is payable in whole or in part from the Edgemont School District treasury, or the spouse of any foregoing is or shall be or become interested, directly or indirectly, as a contracting party, partner, stockholder, surety or otherwise, in this bid, or in the performance of the Contract, or in the supplies, materials or equipment and work or labor to which it relates, or in any portion of the profits thereof.
5. That he/she has carefully examined the site of the work and that, from his/her own investigations, he/she has satisfied him/herself as to the nature and location of the work, and character, quality and quantity of materials, and all difficulties likely to be encountered, the kind and extent of equipment and other facilities needed for the performance of the work, the general and local conditions, and all other items which may, in any way, affect the work or its performance.
6. That if a corporation, this bid or proposal containing the Non-Collusive Binding Certification and the foregoing Affirmation and Declaration has been authorized by the Board of Directors of such Corporation, which authorization includes the signing and submission of this bid or proposal and the inclusion therein of the said Certificate of Non-Collusion and Affirmation and Declaration as the Act and Deed of the Corporation.

1.9 BID FORM SIGNATURE(S)

The Corporate Seal of

(Bidder - print the full name of your firm)

was hereunto affixed in the presence of:

(Authorized signing officer, Title)

(Seal)

(Authorized signing officer, Title)

If the Bid is a joint venture or partnership, add additional forms of execution for each member of the joint venture in the appropriate form or forms as above.

Subscribed and sworn before me this day of ____ 202* ____

Notary Public: _____

My Commission Expire: _____

END OF BID FORM

**SECTION 00 4130
BID FORM CONTRACT #4 ELECTRICAL**

THE PROJECT AND THE PARTIES

TO:

Edgemont School District
300 White Oak Lane:
Scarsdale, NY 10583

FOR:

Administration Building Cafeteria Addition
Edgemont Jr./Sr. High School
300 White Oak Lane
Scarsdale, NY

DATE: _____ (Bidder to enter date)

All information must be typewritten. Handwritten Bid Form will be rejected.

SUBMITTED BY: _____

Bidder's Full Name _____

Address _____

City, State, Zip _____

Contact Individual _____

Telephone No. _____ E-mail: _____

1.1 OFFER

A. Having examined the Place of The Work and all matters referred to in the Bidding Requirements and the Contract Documents prepared by Fuller and D'Angelo, P.C. for Administration Building & Building A Additions, Site Improvements & Related Work, we, the undersigned, hereby offer to enter into a Contract to perform Contract No. 3 Electrical Work for the Sum of:

1. BASE BID

a. The Base Bid of this Proposal for all work required by the Contract Documents for Contract No. 4 Electrical for the Administration Building Additions, Site Improvements & Related Work is as follows:

_____ \$ _____ DOLLARS

b. TOTAL ALLOWANCES

a) The Total Unit Cost Allowance as indicated in Section 01 2100 - Allowances is as follows:
Sixty Four Thousand Five Hundred _____ (\$64,500.00) DOLLARS

c. TOTAL BASE BID

a) The Total Base Bid of this Proposal for all work required by the Contract Documents for Contract No. 4 Electrical for the Administration Building Additions, Site Improvements & Related Work is as follows:

_____ (\$ _____) DOLLARS

(The Total Base Bid is sum of 1.1.A.1.a and 1.1.A.1.b)

Note: Attached Section 01 2100 - Allowances itemized contingency list to bid proposal.

B. The undersigned further understands and agrees that he is to furnish and provide all the necessary material, machinery, plant, implements, tools, labor, services, skill and other items of whatever nature required, and to do and perform all the work necessary under the Contract, to complete the work in

FULLER AND D'ANGELO, P.C.
ARCHITECTS AND PLANNERS

accordance with the drawings and specifications and any addenda thereto, and to accept in full compensation therefore the amount of the Total Base Bid stated, modified by such additive- or deductive alternatives, if any as are accepted by the Owner.

- C. All Allowances described in Section - 01 2100 - Allowances are included in the Total Bid Sum.

1.2 ACCEPTANCE

- A. This offer shall be open to acceptance and is irrevocable for forty-five (45) days from the bid closing date during which time the Owner has the right to enter into a contract, and the bid securities of the three (3) lowest responsible bidders shall be held until the execution of the Contract. Once the bid proposal has been submitted in the sealed envelope, there shall be no alterations or amendments; external markings or separate supplementary information shall, in no way, affect the sealed bid information. The contract will be awarded to the lowest responsible bidder meeting the specifications and furnishing the required security.
- B. Upon award by the Edgemont School District within the time period stated above, we will:
1. Execute the Agreement within ten (10) days of receipt of Notice of Award or five (5) days following receipt of Contract, whichever is later.
 2. Furnish the required Performance and Payment bonds within ten (10) days of receipt of Notice of Award or with the executed Contract.
- C. If this contract is awarded to us and we fail to commence the Work or we fail to provide the required Bonds, the security deposit shall be forfeited as damages to Edgemont School District by reason of our failure, limited in amount to the lesser of the face value of the security deposit or the difference between this bid and the bid upon which a Contract is signed.
- D. In the event our bid is not accepted within the time stated above, the required security deposit shall be returned to the undersigned, in accordance with the provisions of the Instructions to Bidders; unless a mutually satisfactory arrangement is made for its retention and validity for an extended period of time.

1.3 REJECTION OF BIDS

- A. The Owner reserves the right to reject any or all proposals and to waive non-material variances in bid submissions as it deems in the best interests of the Owner.

1.4 CONTRACT TIME

- A. If this Bid is accepted, we will:
1. Complete all the work covered by this Proposal with a commencement date of NO EARLIER THAN Award of Contract by Owner. Work shall be phased as indicated in 01 1000 Summary of Contract. Failure to complete each phase of work by dates indicated will result in liquidated damages as stated in the General Conditions.

1.5 CHANGES TO THE WORK

- A. Refer to Article 8 of the General Conditions.

1.6 ADDENDA

- A. The following Addenda have been received. The modifications to the Bid Documents noted below have been considered and all costs are included in the Bid Sum.
1. Addendum # _____ Dated _____.
 2. Addendum # _____ Dated _____.
 3. Addendum # _____ Dated _____.
 4. Addendum # _____ Dated _____.

1.7 BID FORM SUPPLEMENTS

- A. Section 00 4301 - Bid Form Supplements.

1.8 BIDDER'S FURTHER AFFIRMATION AND DECLARATION

- A. The above named bidder and should this bid be a joint bid each party thereto, further affirm and declares:

Edgemont School District
Administration Building Cafeteria Addition
Site Improvements & Related Work
BID FORM CONTRACT #4 ELECTRICAL

1. That said bidder is of lawful age and the only one interested in this bid; and that no other person, firm or corporation, except those herein above named, has any interest in this bid or in the contract proposed to be entered into.
2. That this bid is made without any understanding, agreement or connection with any other person, firm, or corporation making a bid for the same work, and is in all respects fair and without collusion or fraud.
3. That said bidder is not in arrears to the Edgemont School District upon debt or contract, and is not a defaulter, as surety or otherwise upon any obligation to the said Edgemont School District
4. That no member of the Edgemont School District or any officer or employee of the Edgemont School District or person whose salary is payable in whole or in part from the Edgemont School District treasury, or the spouse of any foregoing is or shall be or become interested, directly or indirectly, as a contracting party, partner, stockholder, surety or otherwise, in this bid, or in the performance of the Contract, or in the supplies, materials or equipment and work or labor to which it relates, or in any portion of the profits thereof.
5. That he/she has carefully examined the site of the work and that, from his/her own investigations, he/she has satisfied him/herself as to the nature and location of the work, and character, quality and quantity of materials, and all difficulties likely to be encountered, the kind and extent of equipment and other facilities needed for the performance of the work, the general and local conditions, and all other items which may, in any way, affect the work or its performance.
6. That if a corporation, this bid or proposal containing the Non-Collusive Binding Certification and the foregoing Affirmation and Declaration has been authorized by the Board of Directors of such Corporation, which authorization includes the signing and submission of this bid or proposal and the inclusion therein of the said Certificate of Non-Collusion and Affirmation and Declaration as the Act and Deed of the Corporation.

1.9 BID FORM SIGNATURE(S)

The Corporate Seal of

(Bidder - print the full name of your firm)

was hereunto affixed in the presence of:

(Authorized signing officer, Title)

(Seal)

(Authorized signing officer, Title)

If the Bid is a joint venture or partnership, add additional forms of execution for each member of the joint venture in the appropriate form or forms as above.

Subscribed and sworn before me this day of ____ 202* ____

Notary Public: _____

My Commission Expire: _____

END OF BID FORM

PLOT DATE: March 17, 2025 - 2:59pm

KEY PLAN

SCALE N.T.S.

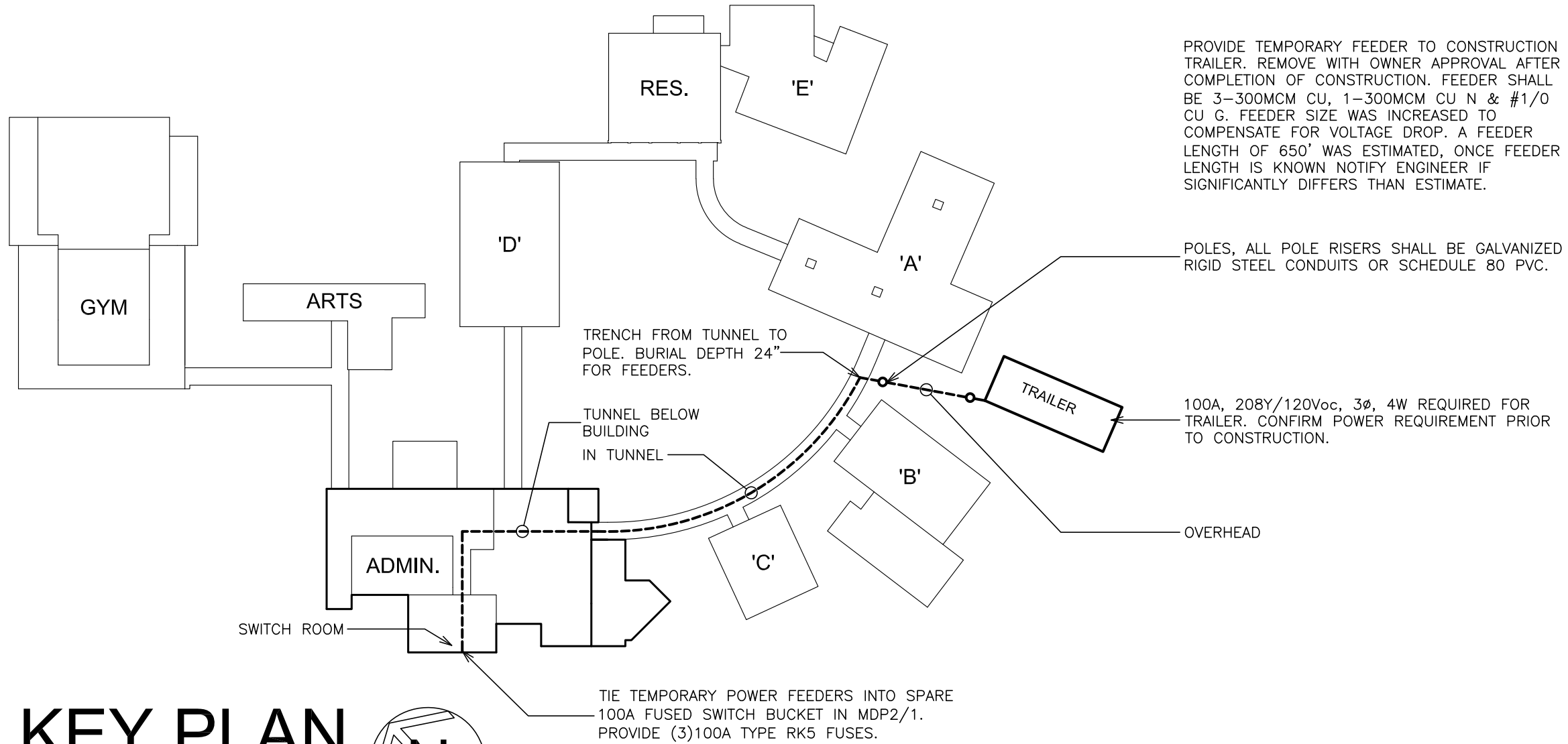
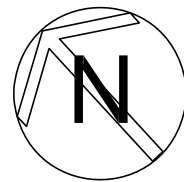

PROJECT TITLE

EDGEMONT SCHOOL DISTRICT
ADMINISTRATION BUILDING ADDITION, SITE
IMPROVEMENTS & RELATED WORK
300 WHITE OAK LANE, SCARSDALE, NY 10583

DRAWING TITLE

TEMPORARY POWER FOR CONSTRUCTION
TRAILER

03-17-2025
DATE

SKETCH

ISSUED TO

FILE NO.
24529.02

DRAWING NO.
SK-E1.0

FULLER
D'ANGELO
P.C.

ARCHITECTS
PLANNERS

45 KNOLLWOOD ROAD ELMSFORD NEW YORK 10523
TEL. 914.892.4444 FAX 914.892.1717
WWW.FULLERDANGELO.COM

Copyright 2025 All Rights Reserved by FULLER & D'ANGELO P.C.

LIGHTING FIXTURE SCHEDULE

TAG	DESCRIPTION	EQUIVALENT MANUFACTURERS AND CATALOG NUMBER	WATTAGE OR LAMPS	QUANTITY*	REMARKS
A	RECESSED 4' LED 1000LM/FT 0-10V DIMMING	ARON DUO-T-BAR DUOT1-F15/16-4FA-1000-B2-35K8-UNV-DM-W	32.4W LED 3500K	0	2
A-EM	RECESSED 4' LED 1000LM/FR 0-10V DIMMING	ARON DUO-T-BAR DUOT1-F15/16-4FA-1000-B2-35K8-UNV-DM-E12W-W	32.4W LED 3500K	0	WIRE EMERGENCY BATTERY AHEAD OF LOCAL SWITCHING
A1	RECESSED 4' LED 750LM/FT 0-10V DIMMING	ARON DUO-T-BAR DUOT1-F15/16-4FA-750-B2-35K8-UNV-DM-W	26.8W LED 3500K	0	
A1-EM	RECESSED 4' LED 750LM/FT 0-10V DIMMING	ARON DUO-T-BAR DUOT1-F15/16-4FA-750-B2-35K8-UNV-DM-E12W-W	26.8W LED 3500K	0	WIRE EMERGENCY BATTERY AHEAD OF LOCAL SWITCHING
A2	RECESSED 4' LED 1250LM/FT 0-10V DIMMING	ARON DUO-T-BAR DUOT1-F15/16-4FA-1250-B2-35K8-UNV-DM-W	40.8W LED 3500K	0	
A2-EM	RECESSED 4' LED 1250LM/FT 0-10V DIMMING	ARON DUO-T-BAR DUOT1-F15/16-4FA-1250-B2-35K8-UNV-DM-E12W-W	40.8W LED 3500K	0	WIRE EMERGENCY BATTERY AHEAD OF LOCAL SWITCHING
B	RECESSED 4.5" ROUND LED 0-10V DIMMING	USA BEVELED 2.2 BASIC B4RDF-12G1-35K5-50-BF-WH-WH-NCSM-UNV-D6E-CB27	12W LED 3500K	40	
B-EM	RECESSED 4.5" ROUND LED 0-10V DIMMING	USA BEVELED 2.2 BASIC B4RDF-12G1-35K5-50-BF-WH-WH-NCSM-UNV-D6E-CB27-EM	12W LED 3500K	3	WIRE EMERGENCY BATTERY AHEAD OF LOCAL SWITCHING
C	SURFACE MOUNT 4' LED STRIP SEALED GASKETED ENCLOSURE WITH IMPACT RESISTANT DIFFUSER 0-10V DIMMING	WILLIAMS 96 96-4-L62/840-HAIFR-DRV-UNV	48W LED 4000K	5	
C-EM	SURFACE MOUNT 4' LED STRIP SEALED GASKETED ENCLOSURE WITH IMPACT RESISTANT DIFFUSER 0-10V DIMMING	WILLIAMS 96 96-4-L62/840-HAIFR-EM/10W-DRV-UNV	48W LED 4000K	2	WIRE EMERGENCY BATTERY AHEAD OF LOCAL SWITCHING
D	RECESSED 2' ROUND LED WITH CONCAVE LENS 0-10V DIMMING	WILLIAMS RND RND-2-L45/835-FCA-(L32)-DIM-UNV	56.6W LED 3500K	51	
D-EM	RECESSED 2' ROUND LED WITH CONCAVE LENS 0-10V DIMMING	WILLIAMS RND RND-2-L45/835-FCA-EM/10W-(L32)-DIM-UNV	56.6W LED 3500K	28	WIRE EMERGENCY BATTERY AHEAD OF LOCAL SWITCHING
E-EM	3" ROTATABLE CRESCENT SUSPENDED DIRECT/INDIRECT LED 0-10V DIMMING DIRECT RGBW DMX INDIRECT	ALW MR3 MR3-R060/3-SS-MIN-80-3500K-0/10V/S-LENS-RGBW-80-3500K-0/10V/S-LENS-GB-GB-UNV-EM/8	29W LED 3500K DIRECT 80W LED 3500K RGBW INDIRECT	1	WIRE EMERGENCY BATTERY AHEAD OF LOCAL SWITCHING (EM DIRECT LIGHT)
E1-EM	3" ROTATABLE CRESCENT SUSPENDED DIRECT/INDIRECT LED 0-10V DIMMING DIRECT RGBW DMX INDIRECT	ALW MR3 MR3-R060/5-SS-MIN-80-3500K-0/10V/S-LENS-RGBW-80-3500K-0/10V/S-LENS-GB-GB-UNV-EM/8	29W LED 3500K DIRECT 80W LED 3500K RGBW INDIRECT	1	WIRE EMERGENCY BATTERY AHEAD OF LOCAL SWITCHING (EM DIRECT LIGHT)
E2-EM	3" ROTATABLE CRESCENT SUSPENDED DIRECT/INDIRECT LED 0-10V DIMMING DIRECT RGBW DMX INDIRECT	ALW MR3 MR3-R060/3-SS-MIN-80-3500K-0/10V/S-LENS-RGBW-80-3500K-0/10V/S-LENS-GB-GB-UNV-EM/8	29W LED 3500K DIRECT 80W LED 3500K RGBW INDIRECT	1	WIRE EMERGENCY BATTERY AHEAD OF LOCAL SWITCHING (EM DIRECT LIGHT)
E3-EM	3" ROTATABLE CRESCENT SUSPENDED DIRECT/INDIRECT LED 0-10V DIMMING DIRECT RGBW DMX INDIRECT	ALW MR3 MR3-R060/3-SS-MIN-80-3500K-0/10V/S-LENS-RGBW-80-3500K-0/10V/S-LENS-GB-GB-UNV-EM/8	29W LED 3500K DIRECT 80W LED 3500K RGBW INDIRECT	1	WIRE EMERGENCY BATTERY AHEAD OF LOCAL SWITCHING (EM DIRECT LIGHT)
F	2" ROUND LINEAR LED WITH ROTATIONAL ARM SYSTEM 0-10V DIMMING	BIRCHWOOD LIGHTING HAI-LED RAS HAI-LED-225B-SLO-35-2-MW-FW-120-D1-RAS-4CP-R3-MW-6	5.8W LED 3500K	5	
G	2'X4' EDGE LIT ARCHED LED PANEL 0-10V DIMMING	WILLIAMS AP AP-24-L70/835-DIM-UNV	66.1W LED 3500K	6	
G-EM	2'X4' EDGE LIT ARCHED LED PANEL 0-10V DIMMING	WILLIAMS AP AP-24-L70/835-EM/10W-DIM-UNV	66.1W LED 3500K	4	WIRE EMERGENCY BATTERY AHEAD OF LOCAL SWITCHING
G1	2'X4' EDGE LIT ARCHED LED PANEL 0-10V DIMMING	WILLIAMS AP AP-24-L50/835-DIM-UNV	44W LED 3500K	6	
G1-EM	2'X4' EDGE LIT ARCHED LED PANEL 0-10V DIMMING	WILLIAMS AP AP-24-L50/835-EM/10W-DIM-UNV	44W LED 3500K	2	WIRE EMERGENCY BATTERY AHEAD OF LOCAL SWITCHING
H	2" CONTINUOUS SUSPENDED LED 0-10V DIMMING	WILLIAMS MX2 MX2D-8'00-L4/835-D-MSF36-DIM-UNV	27.2W LED 3500K	5	
H-EM	2" CONTINUOUS SUSPENDED LED 0-10V DIMMING	WILLIAMS MX2 MX2D-8'00-L4/835-D-MSF36-EM/10WLP-DIM-UNV	27.2W LED 3500K	3	WIRE EMERGENCY BATTERY AHEAD OF LOCAL SWITCHING
I	EXTERIOR LED WALLPACK WITH INTEGRAL PHOTOCELL 0-10V DIMMING	WILLIAMS VWP VWP4-L30/740-T3-SLV-SDGL-PC-DIM-120V	36W LED 4000K	2	
I-EM	EXTERIOR LED WALLPACK WITH INTEGRAL PHOTOCELL 0-10V DIMMING	WILLIAMS VWP VWP4-L30/740-T3-SLV-SDGL-EM/10W-PC-DIM-120V	36W LED 4000K	3	WIRE EMERGENCY BATTERY AHEAD OF LOCAL SWITCHING
J-EM	72" EXTERIOR EGRESS LED WITH INTEGRAL PHOTOCELL 0-10V DIMMING	LUMINAIRE LED AEL AEL-36-MIN1-30W-40K-120-DP-SVH-EMB310-PC	30W LED 4000K	0	WIRE EMERGENCY BATTERY AHEAD OF LOCAL SWITCHING
J1-EM	36" EXTERIOR EGRESS LED WITH INTEGRAL PHOTOCELL 0-10V DIMMING	LUMINAIRE LED AEL AEL-36-MIN1-30W-40K-120-DP-SVH-EMB310-PC	30W LED 4000K	0	WIRE EMERGENCY BATTERY AHEAD OF LOCAL SWITCHING
M-EM	EXTERIOR RECESSED 4.5" ROUND LED 0-10V DIMMING	USA BEVELED 2.2 BASIC B4RDF-12G1-40K5-50-BF-AC-AC-NCSM-UNV-D6E-EMW	12W LED 4000K	0	WIRE EMERGENCY BATTERY AHEAD OF LOCAL SWITCHING
N	EXTERIOR RECESSED RECTANGULAR STEP LIGHT LED 0-10V DIMMING	WILLIAMS S10 S10-H-L3/840-FGT-SLV-DIM-120	14W LED 4000K	4	
P	1/4" X 5" SQUARE STRAIGHT ALUMINUM POLE	US ARCHITECTURAL LIGHTING SNA S SNA 145-125-1-RAL-9005-1		0	
P2	POLE MOUNTED PARKING LOT LED WITH INTEGRAL PHOTOCELL AND STEP DIM MOTION SENSOR	US ARCHITECTURAL LIGHTING TSUNAMI TSU-VLED-II-120LED-525MA-NW-480-1-RAL-9005-T-HS-VLED-PC480V-MS-F211	192W LED 4000K	0	
P3	POLE MOUNTED PARKING LOT LED WITH INTEGRAL PHOTOCELL AND STEP DIM MOTION SENSOR	US ARCHITECTURAL LIGHTING TSUNAMI TSU-VLED-II-120LED-525MA-NW-480-1-RAL-9005-T-PC480V-MS-F211	192W LED 4000K	0	
P4	POLE MOUNTED PARKING LOT LED WITH INTEGRAL PHOTOCELL AND STEP DIM MOTION SENSOR	US ARCHITECTURAL LIGHTING TSUNAMI TSU-VLED-IV-120LED-525MA-NW-480-1-RAL-9005-T-PC480V-MS-F211	192W LED 4000K	0	
EXIT	EXIT SIGN WITH WHICH FACE AND GREEN LETTERS WITH SELF DIAGNOSTICS	LITHONIA LIGHTING LQM S W 3 G MVOLT EL N SD	5W LED MAX GREEN	**	

NOTE: * - FINAL QUANTITIES PER PLANS

LIGHTING CONTROL SCHEDULE

SYMBOL	DESCRIPTION	EQUIVALENT MANUFACTURERS AND CATALOG NUMBER
	1 RELAY ROOM CONTROLLER 0-10V DIMMING 120V 20A	WATTSTOPPER DLM LMRC-211
	2 RELAY ROOM CONTROLLER 0-10V DIMMING 120V 20A	WATTSTOPPER DLM LMRC-212
	1 RELAY ROOM CONTROLLER 0-10V DIMMING 120V 10A	WATTSTOPPER DLM LMRC-111
	CEILING MOUNT DUAL TECH OCCUPANCY SENSOR	WATTSTOPPER DLM LMDC-100
	DIGITAL SINGLE ZONE ON/OFF AND DIMMING CLOSED LOOP PHOTOSENSOR	WATTSTOPPER DLM LMLS-400
	1-BUTTON DIMMING WALL SWITCH WHITE	WATTSTOPPER DLM LMDM-101-W
	DIGITAL 5-BUTTON SCENE SWITCH	WATTSTOPPER DLM LM5W-105-W
	ZONE CONTROLLER	WATTSTOPPER DLM LMZC-301
	EMERGENCY LIGHTING CONTROL UNIT UL924	WATTSTOPPER DLM ELCU-200

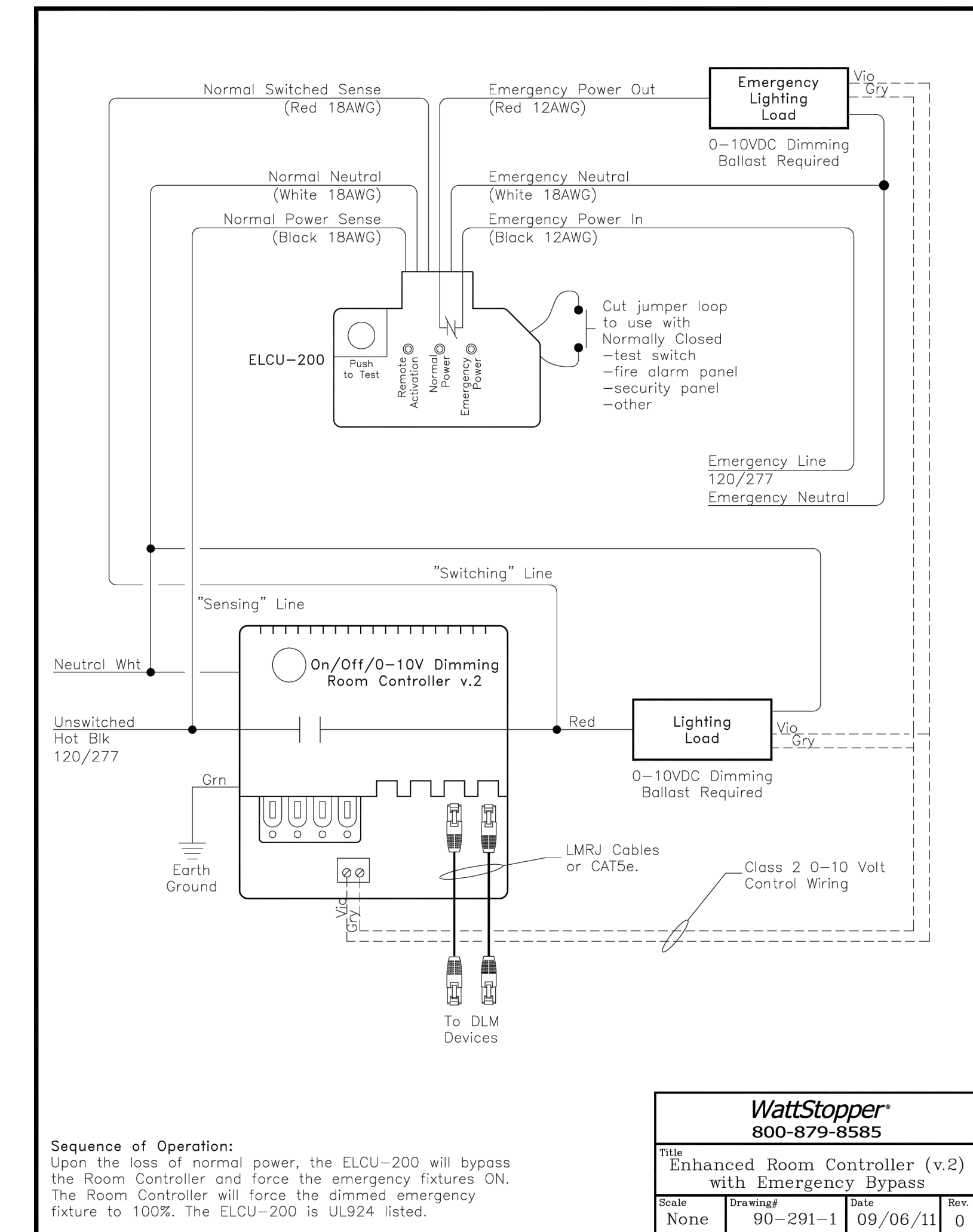
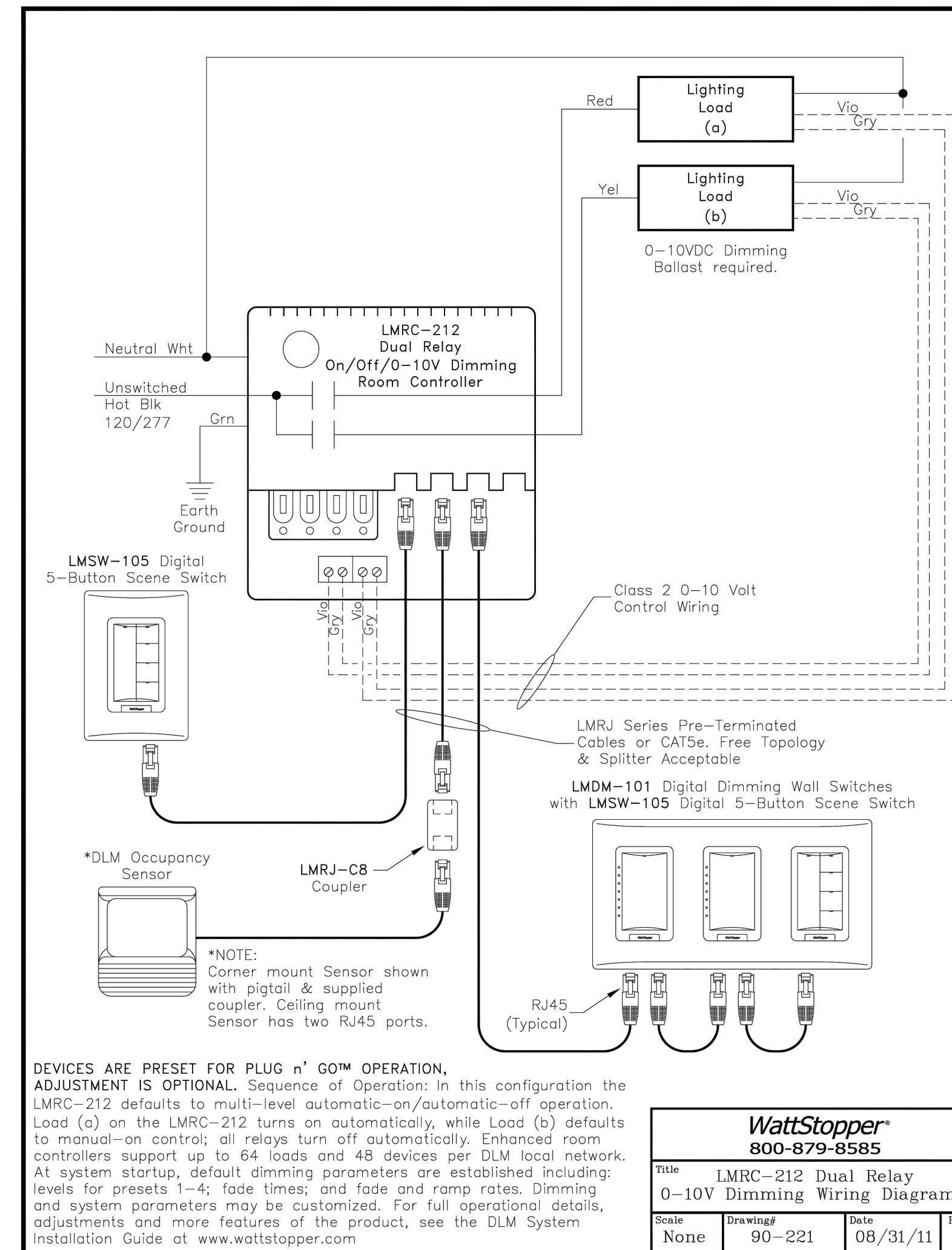

Sequence of Operation:
Upon the loss of normal power, the ELCU-200 will bypass the Room Controller and force the emergency fixtures ON. The Room Controller will force the dimmed emergency fixture to 100%. The ELCU-200 is UL924 listed.

WattStopper
800-879-8585

AS PER USA CONGRESS ARCHITECTURAL WORKS COPYRIGHT PROTECTION ACT OF 1990 ALL IDEAS AND DESIGNS INCLUDING DERIVATIVES THEREOF, ALL DRAWINGS AND SPECIFICATIONS CONSTITUTE THE ORIGINAL COPYRIGHT WORK BY FULLER AND D'ANGELO, P.C. (FAD). THE DRAWINGS AND SPECIFICATIONS AS INSTRUMENTS OF SERVICE BY FAD ARE CREATED AND PROPERTY OF FAD. ANY REPRODUCTION WITHOUT THE PRIOR CONSENT OF FAD IS PROHIBITED.



ALTERNATION OF THESE DOCUMENT EXCEPT BY A NOTATION OF NEW YORK STATE EDUCATION LAW.
480 SULLYWOOD ROAD, ELIZABETH, NEW YORK 07208
TEL: 973-899-4644 FAX: 973-899-1319
Copyright 2022. All Rights Reserved by FULLER & D'ANGELO, P.C.

FULLER & D'ANGELO P.C.
ARCHITECTS & PLANNERS

S.E.D. CONTROL NUMBER
HIGH SCHOOL ADMINISTRATION BUILDING
66-00-00-01-015

PROJECT TITLE
EDGEWOOD SCHOOL DISTRICT
ADMINISTRATION BUILDING ADDITION, SITE IMPROVEMENTS & RELATED WORK
300 WHITE OAK LANE, ELIZABETH, NY 10883

DATE	ISSUED TO
03-18-2025	ADDENDUM #2
03-12-2025	ADDENDUM #1
02-28-2025	BID SET
06-10-2022	S.E.D. SUBMISSION
	DATE
	ISSUED TO
SHEET SIZE 30"x42"	DRAWING NO. E002
SCALE AS NOTED	FILE NO. 24529.02
DRAWN BY LFG	

PLOT DATE: March 18, 2025 - 1:08pm

CIRCUITING NOTES:

CIRCUITING DESIGNATIONS ARE AS FOLLOWS:

(EX. A24) WHERE * IS THE PANEL DESIGNATION AND ## IS THE CIRCUIT DESIGNATION.

PANELS ARE AS FOLLOWS UNLESS NOTE OTHERWISE:

- A = PANEL LP-A
- B = PANEL LP-B
- C = PANEL LP-C
- D = PANEL LP-D

LIGHT FIXTURE ANNOTATION:

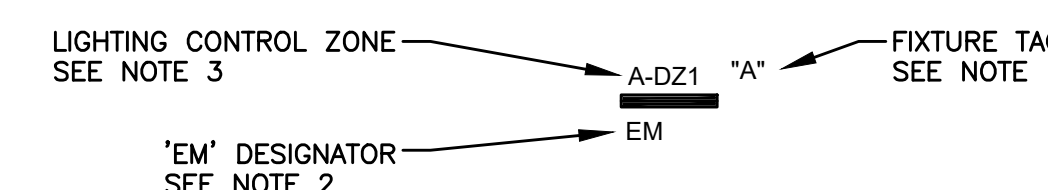

1. LIGHT FIXTURE TAGS DENOTING FIXTURE TYPE ARE IN QUOTATION MARKS AND CONTAIN AT AT LEAST ONE LETTER (EX. "A") IS FIXTURE TAG A ON THE LIGHTING FIXTURE SCHEDULE ON DRAWING E002.
2. AN "EM" DESIGNATOR INDICATES THE FIXTURE SHALL BE PROVIDED WITH AN EMERGENCY POWER BATTERY. ALL FIXTURES REQUIRED TO HAVE EMERGENCY POWER HAVE A VARIANT OF THE FIXTURE IN THE LIGHTING FIXTURE SCHEDULE DENOTED AS "A-EM".
3. THE LIGHTING CONTROL ZONE DESIGNATOR IS MADE UP OF LETTERS FOUND ON THE LIGHTING CONTROL ZONES NOTE. THIS INDICATES THE TYPE OF LIGHTING CONTROL REQUIRED. A FIXTURE WITH A CONTROL ZONE WITH "-DZ1" APPENDED TO THE END OF IT (EX. A-DZ1) IS PART OF A DAYLIGHT CONTROL AREA, CONTINUOUS DAYLIGHT REDUCTION CONTROLS SHALL BE PROVIDED.

GENERAL NOTES:

1. INSTALL LIGHTING CONTROL PER MANUFACTURER'S INSTRUCTIONS AND WIRING DIAGRAMS.
2. CONTRACTOR SHALL ENSURE LIGHTING CONTROL MEETS & IS COMMISSIONED TO COMPLY WITH THE 2020 ENERGY CONSERVATION CODE OF NEW YORK STATE.

LIGHTING CONTROL ZONES:

ZONE	DESCRIPTION	CONTROL
A	CAFETERIA	MANUAL DIMMING, OCCUPANCY SENSOR (AUTO-ON 100%, AUTO-OFF 15 MIN), CONTINUOUS DAYLIGHT DIMMING
B	OFFICE	MANUAL DIMMING, OCCUPANCY SENSOR (MANUAL-ON, AUTO-OFF 15 MIN)
C	CORRIDOR	OCCUPANCY SENSOR (ALWAYS ON 30%, AUTO-ON 100%, AUTO-OFF 15 MIN), SCHEDULED WITH MANUAL OVERRIDE
D	TOILET	OCCUPANCY SENSOR (AUTO-ON 100%, 15 MIN)
E	UNUSED	
F	IT, JANITORIAL, STORAGE	VACANCY WALL SWITCH (MANUAL-ON, AUTO-OFF 15 MIN)
G	MECH. ROOM	MANUAL SWITCH
H	ELEC. ROOM	UNUSED
I	UNUSED	
J	KITCHEN	OCCUPANCY SENSOR (AUTO-ON 30%, MANUAL-ON 100% 15 MIN)
K	SERVERY	OCCUPANCY SENSOR (AUTO-ON 30%, MANUAL-ON 100% 15 MIN)

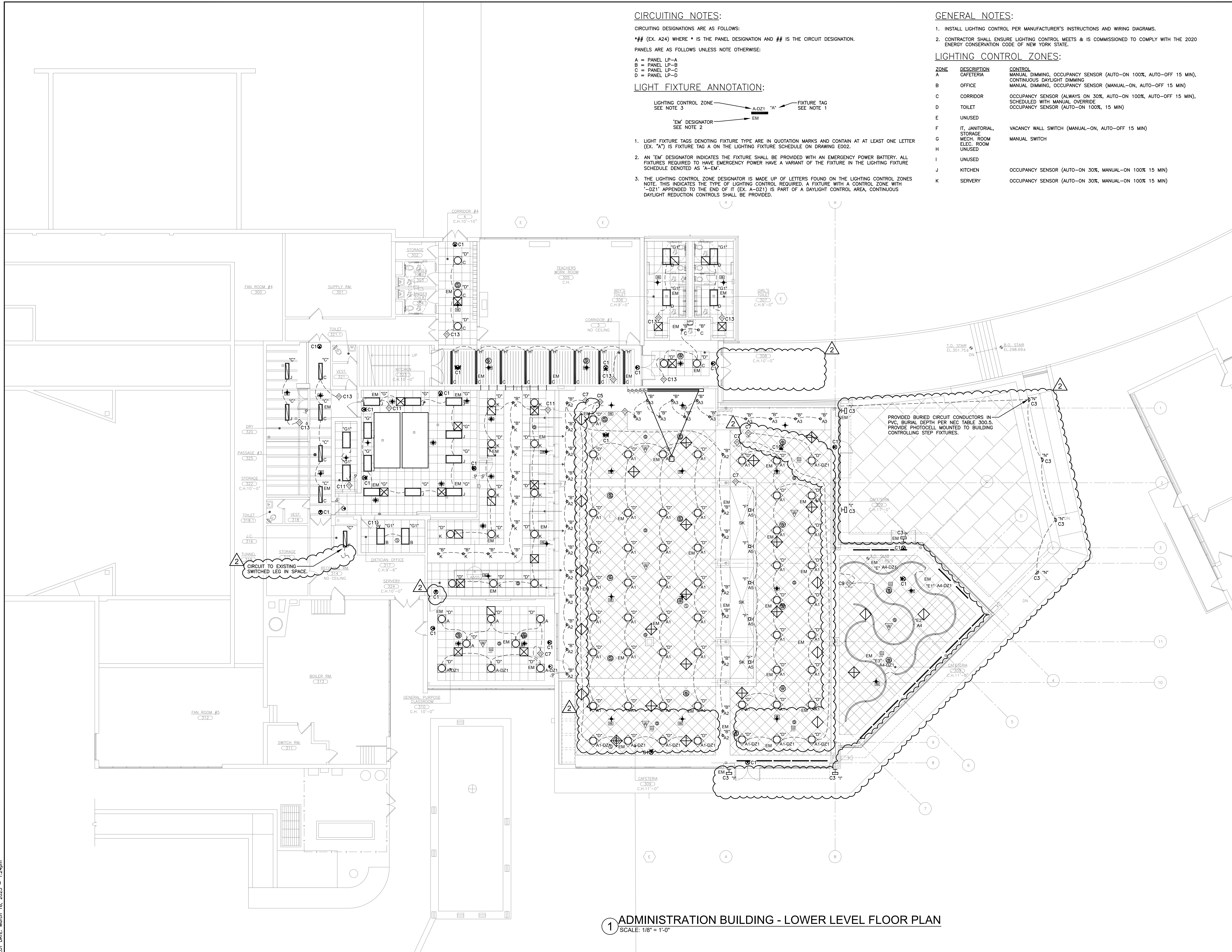

PROVIDED BURIED CIRCUIT CONDUCTORS IN PVC. BURIAL DEPTH PER NEC TABLE 300.5. PROVIDE PHOTOCELL MOUNTED TO BUILDING CONTROLLING STEP FIXTURES.

2 CIRCUIT TO EXISTING SWITCHED LEG IN SPACE.

1 ADMINISTRATION BUILDING - LOWER LEVEL FLOOR PLAN
SCALE: 1/8" = 1'-0"

AS PER USA CONGRESS ARCHITECTURAL WORKS COPYRIGHT PROTECTION ACT OF 1990 ALL IDEAS AND DESIGNS INCLUDING DERIVATIVES THEREOF, ALL DRAWINGS AND SPECIFICATIONS CONSTITUTE THE ORIGINAL COPYRIGHT WORK BY FULLER AND D'ANGELO, P.C. (FAD). THE DRAWINGS AND SPECIFICATIONS AS INSTRUMENTS OF SERVICE BY FAD ARE CREATED BY FAD FOR THIS PROJECT ONLY AND REMAIN THE PRODUCT AND PROPERTY OF FAD. ANY REPRODUCTION WITHOUT THE PRIOR CONSENT OF FAD IS PROHIBITED.



ALTERNATION OF THESE DOCUMENT EXCEPT BY A NOTATION OF NEW YORK STATE EDUCATION LAW.

48 SULLYWOOD ROAD, ELIZABETH, NEW YORK 10828
TEL: 914-899-4444 FAX: 914-899-1919
Copyright 2025. All Rights Reserved by FULLER & D'ANGELO, P.C.

**FULLER
D'ANGELO
P.C.**
ARCHITECTS
PLANNERS

S.E.D. CONTROL NUMBER
HIGH SCHOOL ADMINISTRATION BUILDING
66-04-00-001-015

PROJECT TITLE
EDGE MOUNT SCHOOL DISTRICT
ADMINISTRATION BUILDING ADDITION, SITE
IMPROVEMENTS & RELATED WORK
300 WHITE OAK LANE, SCARSDALE, NY 10583

DRAWING TITLE
**LOWER LEVEL ELECTRICAL
LIGHTING PLAN**

03-18-2025	ADDENDUM #2
03-12-2025	ADDENDUM #1
02-28-2025	BID SET
06-10-2022	S.E.D. SUBMISSION
DATE	ISSUED TO
SHEET SIZE 30"x42"	DRAWING NO. AD E120
SCALE AS NOTED	FILE NO. 24529.02
DRAWN BY LFG	