

Penny Sikes 5th and 6th Grade Mathematics Tournament
Sponsored by Farmers and Merchants Bank

6th Grade Individual Test

- 1) Make sure your name, the full name of your school, and your grade are written on the scantron.
- 2) NO CALCULATORS!
- 3) DO NOT OPEN THIS TEST BOOKLET UNTIL INSTRUCTED TO DO SO BY THE TEST MONITOR.
- 4) If you must leave to go to the restroom, raise your hand and a monitor will escort you to the nearest restroom. Remember you have a time limit.
- 5) Read each problem carefully and mark each answer on your scantron.
- 6) Each correct answer on the test will be counted as one point on your individual score.
- 7) If individuals have the same written test score, ties will be broken by determining which student gave correct answers to the most difficult item(s) on the test.
- 8) When the individual testing is over, please make sure you take your pencil, test, and scratch work with you. You will need the pencil for the ciphering rounds.

Southeast Bulloch High School 5th and 6th Grade Mathematics Tournament
April 19, 2008

6th Grade Test

Name _____

1. Complete the statement. 108 inches = _____ yards

- (a) 3 (b) 6 (c) 9 (d) 12

2. Widget Industries had stock that sold at $30\frac{1}{8}$. After a takeover bid, the stock rose $4\frac{1}{4}$ points. What was the new price?

- (a) $34\frac{3}{8}$ points (b) $34\frac{1}{8}$ points (c) $26\frac{1}{8}$ points (d) $25\frac{7}{8}$ points

3. You are buying supplies for a birthday party. You figure that a 2-liter bottle of juice will serve 7 guests. How many 2-liter bottles will you need if you invite 84 guests?

- (a) 24 (b) 6 (c) 12 (d) 14

4. Find the value of x. Perimeter = $9\frac{2}{5}$ mm

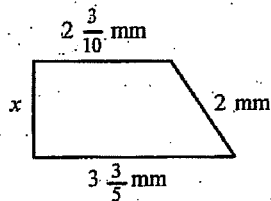

- (a) $1\frac{1}{2}$ mm (b) $1\frac{1}{5}$ mm (c) $1\frac{1}{10}$ mm (d) 1 mm

5. One day, 20% of the students at Ridge School went to the zoo. That left 240 students at school for the day. How many students went on the field trip?

- (a) 24 (b) 48 (c) 72 (d) 60

6. Each small square in the grid is 1 unit by 1 unit. Find the area of the triangle.

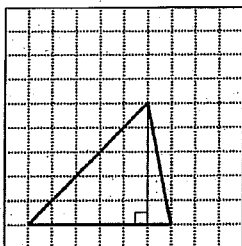

- (a) 30 square units (b) 32 square units (c) 15 square units (d) 11 square units

7. Find the area of the circle.

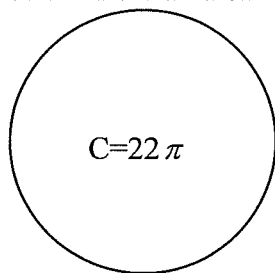

- (a) $44\pi \text{ ft}^2$ (b) $121\pi \text{ ft}^2$ (c) $484\pi \text{ ft}^2$ (d) $11\pi \text{ ft}^2$

8. What is $\frac{1}{2}\%$ of 500?

- (a) 250 (b) 1000 (c) 25 (d) 2.5

9. Evaluate : $20 - 12 \div 2 \times 3 + 9$

- (a) 21 (b) 27 (c) 11 (d) 19.2

10. Choose the value that makes the statement true $137.5\% > \underline{\hspace{2cm}}$

- (a) $\frac{137}{5}$ (b) $1\frac{3}{8}$ (c) $1\frac{1}{2}$ (d) $1\frac{1}{8}$

11. Which of the following equations is satisfied by pairs of numbers in the table below?

x	0	3	6	9
y	-3	0	3	6

- I. $y = x + 3$
- II. $x = y + 3$
- III. $y = x - 3$

- (a) II only (b) I and II only (c) II and III only (d) I only

12. Determine which coordinates are the midpoints of the sides of the quadrilateral.

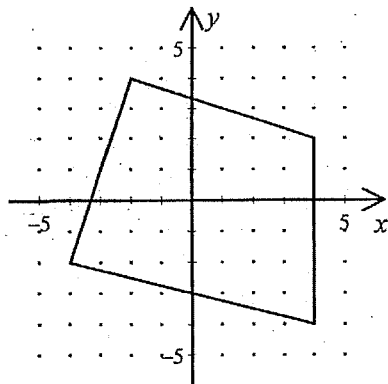

- (a) (1,-3), (3,1), (-1,4), (-3,0) (b) (-1,3), (-3, -1), (1,-4), (3,0)
- (c) (3,-1), (-1,-3), (-4,1), (0,3) (d) (-3,1), (1,3), (4,-1), (0,-3)

13. The line plot below represents the number of movies seen in a year by middle school students. Each x represents 10 students. How many students saw 10 or fewer movies?

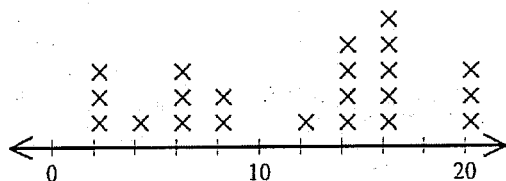

- (a) 80 students (b) 9 students (c) 90 students (d) 130 students

14. A map has a scale of 5 cm to 9 km. Which proportion would NOT allow you to solve the problem of how far two cities are from each other if they are 2 cm part on the map?

- (a) $\frac{9}{5} = \frac{x}{2}$ (b) $\frac{5}{2} = \frac{9}{x}$ (c) $\frac{5}{2} = \frac{x}{9}$ (d) $\frac{5}{9} = \frac{2}{x}$

15. The hourly parking fees for the local airport from 1986 through 1996 are shown on the line graph below. Using this information, predict what the hourly parking fee was for 1998.

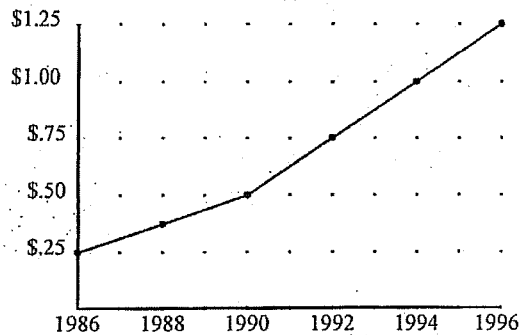

- (a) \$1.25 per hour (b) \$1.62 per hour (c) \$1.37 per hour (d) \$1.50 per hour

16. $\sqrt{100} = \sqrt{36} + \sqrt{?}$

- (a) 2 (b) 4 (c) 16 (d) 64

17. Game wardens use experiments to help determine the number of fish in a lake. Suppose 75 fish are caught, tagged, and released back into the lake. Two weeks later 50 fish are caught, of which 5 are found to have tags. Using this information, estimate the number of fish in the lake.

- (a) 120 (b) 70 (c) 3750 (d) 750

18. Find the prime factorization of 2520.

- (a) $2 \times 4 \times 5 \times 7 \times 9$ (b) $3^2 \times 5 \times 7 \times 8$ (c) $2^3 \times 5 \times 7 \times 9$ (d) $2^3 \times 3^2 \times 5 \times 7$

19. Marilyn's age in 9 years will be twice what it was 15 years ago. How old is Marilyn now?

- (a) 26 (b) 24 (c) 41 (d) 39

20. There is an advertisement in an auto parts store:

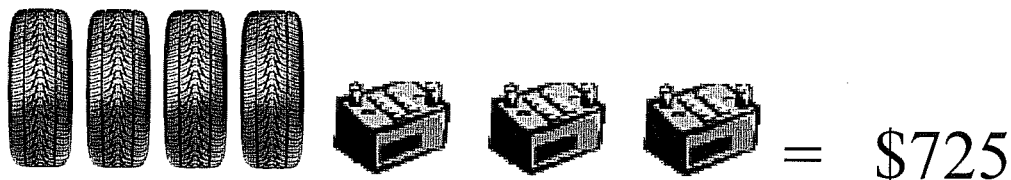

How much is a tire?

- (a) \$75 (b) \$150 (c) \$250 (d) \$125

21. What is $\frac{1}{9}$ of $\frac{4}{6}$ of a mile ?

- (a) 54 miles (b) $\frac{1}{6}$ mi (c) $\frac{2}{27}$ mi (d) 36 mi

22. Kim invested money in stocks and bonds. Her profit from these investments was \$615. If the stocks earned \$85 more than the bonds, how much money did Kim receive from each type of investment?

- (a) \$370 from stocks, \$245 from bonds (b) \$350 for stocks, \$265 from bonds
(c) \$265 from stocks, \$350 from bonds (d) \$340 from stocks, \$275 from bonds

23. There are 32 students in your math class. Of these students, 21 made the honor roll and 13 earned A's in math. If 5 students earned both, how many students did not earn either A's in math or honor roll?

- (a) 5 (b) 9 (c) 3 (d) 2

24. Franco went to the mall with his friends. He spent half of the money he took with him on videos and one-fourth of the remaining money on lunch. If he spent \$6.50 on lunch, how much money did he take with him?

- (a) \$39.00 (b) \$26.00 (c) \$32.50 (d) \$52.00

25. The map below gives the distances, in miles, between various locations in a state park. Traveling the shortest distance along the paths shown on the map, from the visitor center Teresa visits the cave, waterfall, and monument, but not necessarily in that order, and then returns to the visitor center. If she does not retrace her steps along any path and the total distance that Teresa travels is 14.7 miles, what is the distance between the cave and the monument?

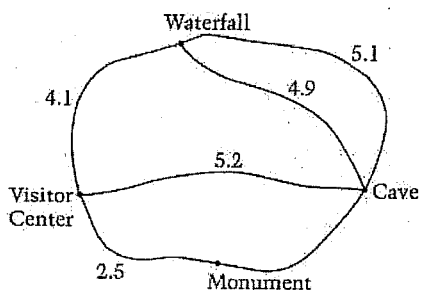

- (a) 2.5 miles (b) 2.7 miles (c) 3.0 miles (d) 3.2 miles

26. Marla wound a cord $3\frac{1}{3}$ times around a spool with a $\frac{1}{3}$ meter circumference. How many meters of cord did she wind?

- (a) $\frac{1}{10}$ meters (b) $1\frac{1}{9}$ meters (c) $\frac{9}{10}$ meters (d) 10 meters

27. A survey asked teens to name their favorite sport. Of the 200 asked, $\frac{3}{10}$ chose soccer, $\frac{1}{5}$ chose track, $\frac{3}{20}$ chose swimming, $\frac{8}{25}$ chose gymnastics, and $\frac{3}{100}$ chose golf. How many teens chose gymnastics as their favorite sport?

- (a) 128 (b) 32 (c) 8 (d) 64

28. Which equation describes the data in the table below?

X	1	2	3	4	5	6
Y	2.5	3	3.5	4	4.5	5

- (a) $y = .5x + .5$ (b) $y = 2x + .5$ (c) $y = x + 2$ (d) $y = .5x + 2$

29. The 500 ballots from the Student Council President election were placed in a paper bag. The voting results were: 265 for Marc, 125 for Wanda, 75 for Ken, and 35 for Sylvia. What is the probability that a ballot drawn would have Ken's name on it?

- (a) 0.1 (b) 0.15 (c) 0.013 (d) 0.75

30. There is a law stating that "the ratio of the width to length of the American flag should be 10 to 19". Which one of the following flags is not in the correct ratio?

- (a) 60 in by 114 in (b) 30 ft by 57 ft (c) 20 in by 38 in (d) 20 ft by 45 ft

31. If $3x - 1 = 11$ and $5y + 2 = 3y + 34$, then $x + y = ?$

- (a) 45 (b) 21 (c) 35 (d) 20

32. Approximately what percent of Charles' total monthly earnings is used for car expenses?

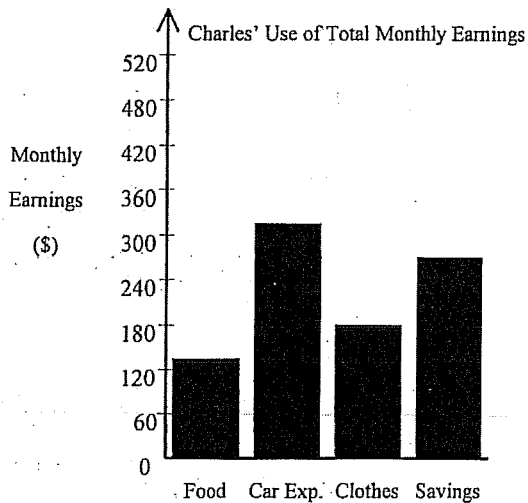

- (a) 315% (b) 45% (c) 30% (d) 35%

33. You have small cans of paint that will cover 1728 square inches. You need to paint all sides of 22 boxes that are 4 inches by 8 inches by 10 inches. How many cans of paint will you need to open to complete the job?

- (a) 5 cans (b) 6 cans (c) 4 cans (d) 3 cans

37. The figure below represents the overhead view of a deck surrounding a hot tub. What is the area of the deck? Use $\pi = 3.14$

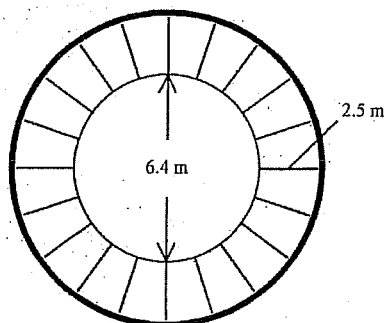

- (a) 375.921 sq m (b) 32.1536 sq m (c) 102.019 sq m (d) 69.865 sq m

38. Draw the image when the figure is rotated in a coordinate plane 270 degrees clockwise about D.

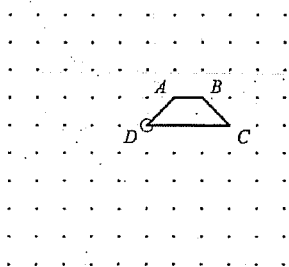

[A]

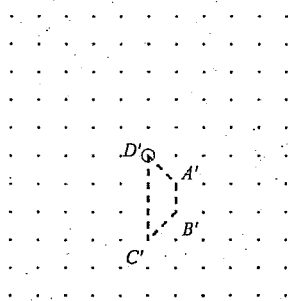

[B]

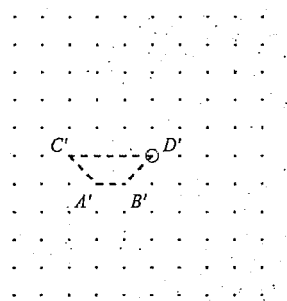

[C]

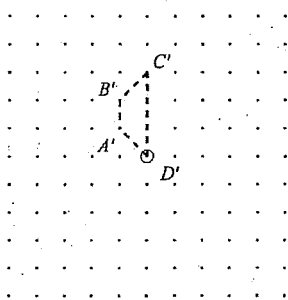

[D]

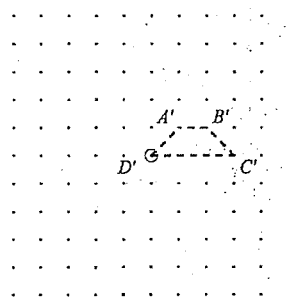

44. Easy Ride Van Company finds that about 40 percent of the time a person who makes an advance reservation for transportation does not keep the reservation. Therefore, for each of their 10 passenger vans, the Easy Ride Van Company schedules 13 persons on the basis of advance reservations. Based on the information above, about how many riders out of the 13 scheduled would not keep their reservations?

- (a) 1 (b) 3 (c) 5 (d) 7

45. According to the pattern suggested in the four examples below, how many consecutive odd integers are required to give a sum of 144?

$$1 + 3 = 4$$

$$1 + 3 + 5 = 9$$

$$1 + 3 + 5 + 7 = 16$$

$$1 + 3 + 5 + 7 + 9 = 25$$

- (a) 9 (b) 12 (c) 15 (d) 36

46. The distance around a circular pond is shown below. From the snack bar, Jake notices an island in the center of the pond. Of the following, which is the best approximation of the distance from the snack bar to the center of the island?

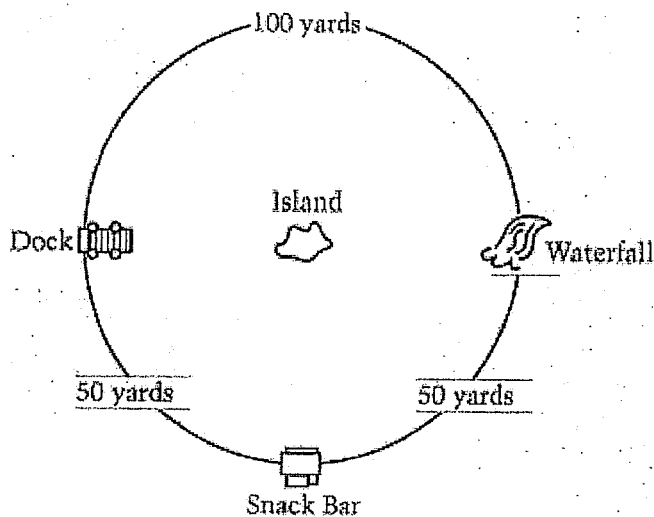

- (a) 16 yards (b) 20 yards (c) 32 yards (d) 64 yards

47. What number is represented by point A on the number line below?

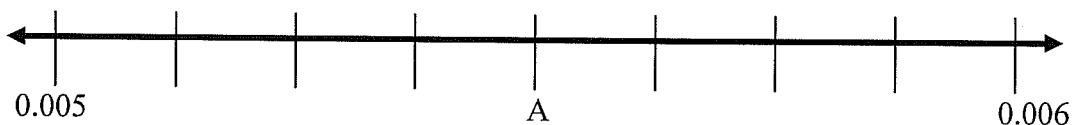

- (a) 0.0010 (b) 0.0054 (c) 0.0055 (d) 0.055

48. Which of the following can be folded to form the prism below?

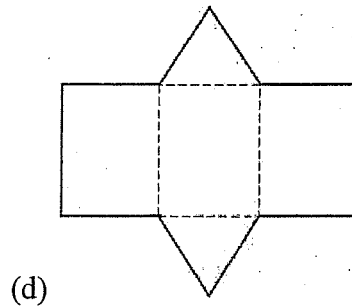
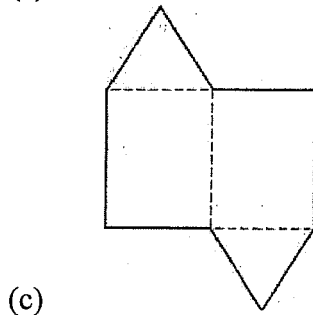
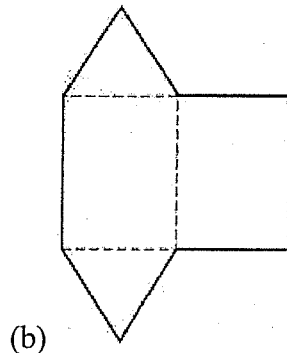
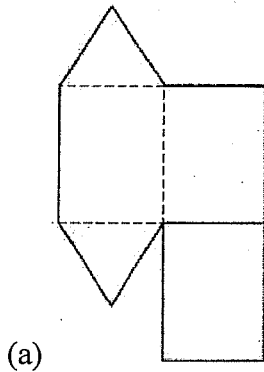
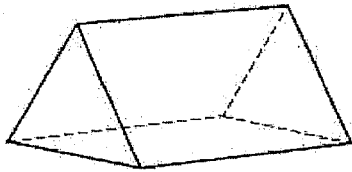

49. If the digit in the tens place of 37,241 is increased by one and the digit in the thousands place is decreased by one, how has the number been changed?

- (a) the number has been decreased by 990 (b) the number has been decreased by 1,000
(c) the number has been decreased by 1,010 (d) the number has been increased by 1,010

50. A rope 32 feet long is to be cut into pieces that are $\frac{1}{8}$ of a foot long. How many pieces can be obtained?

- (a) 256 pieces (b) 2000 pieces (c) 320 pieces (d) 4 pieces

Southeast Bulloch High School Fifth & Sixth Grade Mathematics Tournament
April 19, 2008
Sixth Grade Division Item Analysis

Number	Answer	Percent Correct
1.	A	91%
2.	A	98%
3.	C	90%
4.	A	89%
5.	D	71%
6.	C	93%
7.	B	73%
8.	D	71%
9.	C	83%
10.	D	76%
11.	C	93%
12.	D	68%
13.	C	95%
14.	C	84%
15.	D	88%
16.	C	77%
17.	D	63%
18.	D	86%
19.	D	81%
20.	D	83%
21.	C	79%
22.	B	83%
23.	C	83%
24.	D	71%
25.	D	66%
26.	B	79%
27.	D	80%
28.	D	79%
29.	B	88%
30.	D	85%
31.	D	70%
32.	D	62%
33.	C	68%
34.	C	88%
35.	B	61%
36.	A	80%
37.	D	59%
38.	C	73%
39.	C	61%
40.	A	60%
41.	A	66%
42.	D	65%
43.	D	61%
44.	C	62%
45.	B	60%
46.	C	60%
47.	C	59%
48.	D	64%
49.	A	57%
50.	A	59%