

2016 Penny Sikes Math Tournament

5th Grade Exam

1. Simplify: $4.24 \div 0.02 =$

- [A] 212 [B] 21.2 [C] 2.12 [D] 0.212

2. Verizon wireless advertised five different monthly plans for its cellular phones, as shown in the table below.

Monthly cost	\$39.99	\$59.99	\$79.99	\$104.99
Number of minutes per month	400	800	1200	1500

The cheapest plan in dollars per minute is:

- [A] 400 [B] 800 [C] 1200 [D] 1500

3. The perimeter of a rectangle with length 4 and width 3 is

- [A] 7 [B] 12 [C] 14 [D] 25

4. The first two numbers in a sequence are 3 and 4. Every number after that is the sum of the two preceding it. What will the sixth number in the sequence be?

- [A] 7 [B] 18 [C] 22 [D] 29

5. Derek and his friends kept track of how much their height increased, in inches, over the past year. The line plot below shows this information.

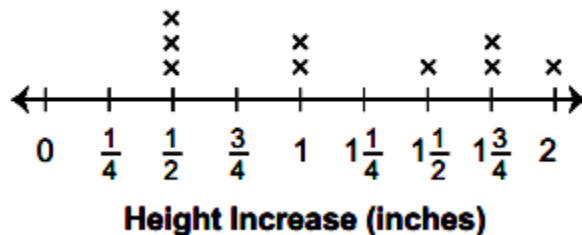

A year ago Derek was $52 \frac{1}{4}$ inches tall. Which height could he be now?

- [A] $52 \frac{1}{2}$ inches [B] 53 inches [C] $53 \frac{1}{2}$ inches [D] 54 inches

6. Which statement is true?

- [A] All hexagons are triangles because they have at least 3 sides.
- [B] All octagons are polygons because they have at least 3 sides.
- [C] All parallelograms are rectangles because they have 2 sets of parallel sides.
- [D] All rhombi are squares because they have 4 sides that are all the same length.

7. Thirty cubes were used to construct this 3-step staircase. How many cubes would be used to construct a 10-step staircase of the same width?

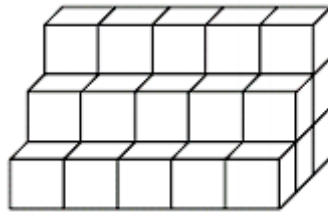

- [A] 100
- [B] 180
- [C] 240
- [D] 275

8. Which equation shows how to multiply $6 \times 5 \times 3$ using the associative property?

- [A] $6 \times 5 \times 3 = 3 \times 5 \times 6$
- [B] $(6 \times 3) + 5 = 6 \times (3 + 5)$
- [C] $(6 \times 5) \times 3 = 6 \times (5 \times 3)$
- [D] $(6 \times 5) + (6 \times 3) = (6 \times 3) + (6 \times 5)$

9. What is the standard form of twenty-one and six hundred thirty-four ten thousandths?

- [A] 21.06034
- [B] 21.6034
- [C] 21.634
- [D] 21.0634

10. How many of the whole numbers from 1 to 100 are divisible by 3?

- [A] 30
- [B] 31
- [C] 33
- [D] 34

11. What is $92.53 \div 10$?

- [A] 0.9253
- [B] 9.253
- [C] 92.53
- [D] 925.3

12. Josh poured 38 gallons of water into 6 buckets. He poured the same amount into each bucket. How much water did Josh pour into each bucket?

[A] $6\frac{4}{6}$ gallons

[B] $6\frac{1}{2}$ gallons

[C] $6\frac{1}{3}$ gallons

[D] $6\frac{1}{6}$ gallons

13. The total length of three boards is $\frac{7}{8}$ of a yard. The lengths of two of the boards are $\frac{1}{4}$ of a yard and $\frac{3}{16}$ of a yard. What is the length of the third board?

[A] $\frac{9}{16}$ of a yard

[B] $\frac{1}{2}$ of a yard

[C] $\frac{7}{16}$ of a yard

[D] $\frac{3}{8}$ of a yard

14. Which numbers belong in the intersection?

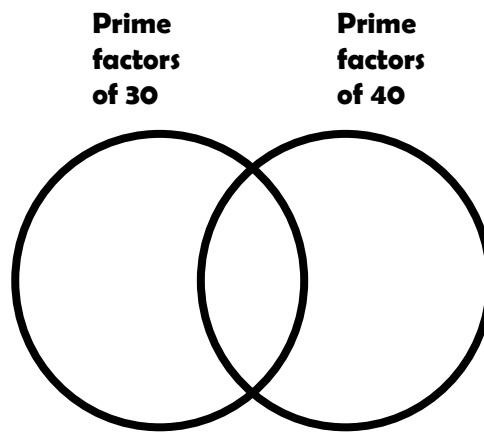

[A] 2 and 3

[B] 2 and 5

[C] 3 and 5

[D] 2, 3, and 5

15. What is the value of this expression?

$$6\frac{7}{8} + 4\frac{3}{4} + 8\frac{1}{2}$$

[A] $20\frac{1}{8}$

[B] $19\frac{3}{8}$

[C] $18\frac{11}{14}$

[D] $18\frac{1}{2}$

16. Two-thirds of the students in a class are wearing blue jeans. Two-sixths of the students who are wearing blue jeans are also wearing red shirts. What fraction of the students in the class are wearing blue jeans and red shirts?

[A] $\frac{1}{9}$

[B] $\frac{2}{9}$

[C] $\frac{1}{3}$

[D] $\frac{4}{9}$

17. Each smaller cube in this right rectangular prism has a volume of 1 cubic unit.

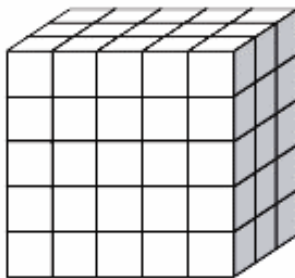

What is the volume of this prism?

- [A] 25 cubic units [B] 50 cubic units [C] 75 cubic units [D] 100 cubic units

18. A solid geometric figure is shown below.

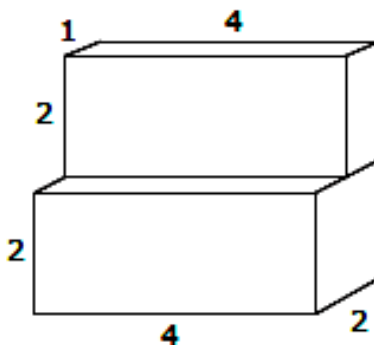

What is the volume (in cubic units) of the solid figure?

- [A] 12 [B] 15 [C] 24 [D] 30

19. Ms. Phillips is buying food for a picnic. She went to a discount store that sells food that is boxed in large amounts.

Item	Amount per Box
Hot dogs	15
Hot dog buns	10
Bags of potato chips	12

What is the least number of bags of potato chips that Ms. Phillips should buy in order to have the same number of hot dogs, hot dog buns, and bags of potato chips?

- [A] 3 [B] 4 [C] 5 [D] 6

20. Angie's times for each lap of her mile run were 1.182, 1.156, 1.114, and 1.137. What set of numbers shows the lap times in order from least to greatest?

[A] $1.114 < 1.137 < 1.156 < 1.182$

[B] $1.114 < 1.156 < 1.137 < 1.182$

[C] $1.182 < 1.156 < 1.137 < 1.114$

[D] $1.182 < 1.156 < 1.114 < 1.137$

21. The coach used a digital stopwatch to time a race. The fastest time was recorded on this stopwatch:



When the race was over, the coach posted the winning time in fraction form. Which is the winning time?

[A] $\frac{17}{1000}$

[B] $1\frac{7}{10}$

[C] $1\frac{7}{100}$

[D] $1\frac{7}{1000}$

22. Harriet, Jim, Roberto, Maria, and Willie are in the same eighth-grade class. One of them is this year's class president. Based on the following information, who is the class president?

- The class president was last year's class vice president and lives on Vine Street.
- Willie is this year's class vice president.
- Jim and Maria live on Cypress Street
- Roberto was not last year's class vice president.

[A] Harriet

[B] Roberto

[C] Maria

[D] Willie

23. Which has the smallest area?

[A] a rectangle 9 in x 4 in

[B] a square 12 in x 1 ft

[C] a rectangle 1 ft x 3 ft

[D] a square 1 yd x 1 yd

24. The town council wants to have a circular walking trail around the park.

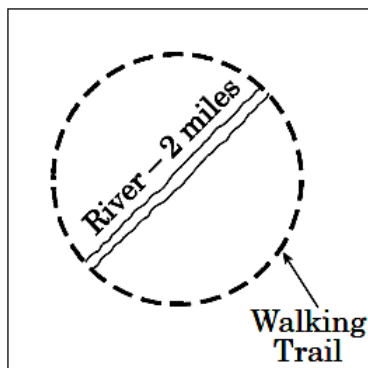

About how long will the walking trail be?

- [A] 2 miles [B] 6 miles [C] 8 miles [D] 12 miles

25. $\triangle \triangle = \square \triangle \square$ $\triangle \square = \bigcirc \bigcirc$

$$\triangle = 50$$

Using the diagram above, which of the following statements is true?

- A $\bigcirc < \triangle$
- B $\square > \bigcirc$
- C $\triangle < \square$
- D $\triangle < \bigcirc$

26. After science class, Stacy interviewed her classmates to find out how many rocks they had in their collections. She recorded the following data:

15, 21, 12, 8, 25, 20, 18, 15, 11, and 15

Which statement is true about Stacy's findings?

- [A] The range of the data is 15.
- [B] The mean of the data is 160.
- [C] The median of the data is 25.
- [D] The mode of the data is 15.

27. Simplify: $738 \div 18$

[A] 40

[B] 41

[C] 401

[D] 410

28. Four hundred sixty-nine and eight hundredths can also be written as

[A] 460.908

[B] 460.98

[C] 469.08

[D] 469.800

29. What is the area of the shaded ring below if the inside diameter is 8 inches and the outside diameter is 10 inches long?

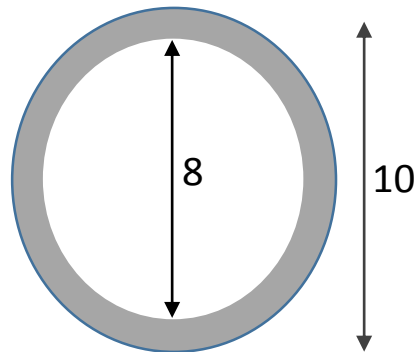

[A] $2\pi \text{ in}^2$

[B] $9\pi \text{ in}^2$

[C] $36\pi \text{ in}^2$

[D] $100\pi \text{ in}^2$

30. Sarah ran $4\frac{3}{4}$ miles on Monday, $3\frac{1}{2}$ miles on Tuesday, and $5\frac{1}{3}$ miles on Wednesday. If her goal is to run 19 miles per week, and she divides the remaining miles left evenly between Thursday and Friday, how many miles must she run on Friday?

[A] $6\frac{5}{24}$

[B] $3\frac{5}{24}$

[C] $3\frac{7}{24}$

[D] $2\frac{17}{24}$

31. A bag contains lemon and limes. The ratio of lemons to limes is 4 to 11. How much fruit is in the bag if there are 44 lemons?

[A] 121

[B] 156

[C] 165

[D] 137

32. Express $\frac{3}{25}$ as a percent.

[A] 3%

[B] 12%

[C] 25%

[D] 325%

33. Find the volume of the rectangular prism. Round to the nearest tenth.

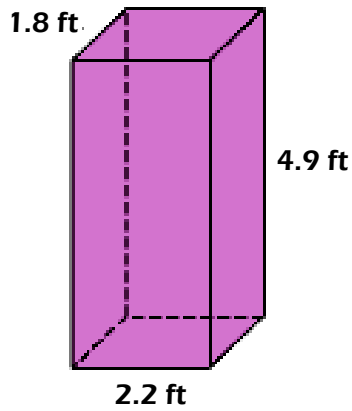

[A] 20 ft^3

[B] 38.8 ft^3

[C] 9.7 ft^3

[D] 19.4 ft^3

34. Graph $J(2, 5)$

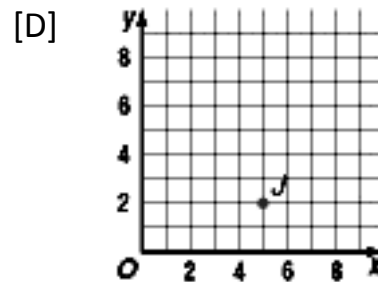
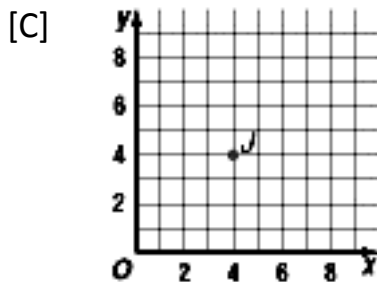
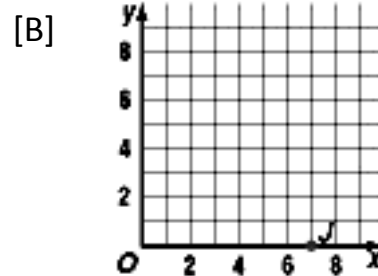
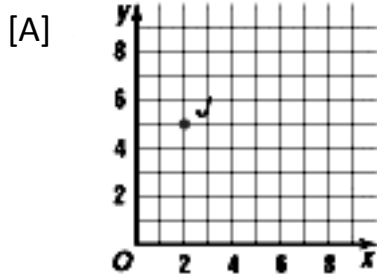

35. Select the figure that has no lines of symmetry.

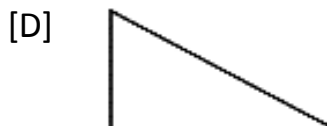
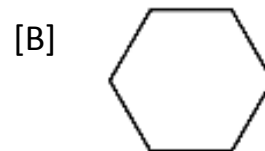

41. The Allen family needs to set aside \$3,000 for monthly expenses. The list below shows where the money is spent.

Food	\$600
Housing	\$1,500
Electricity and Telephone	\$200
Clothes	\$200
Car Repairs and Gas	\$300
Emergencies and Children's Allowances	\$200

If a circle graph is constructed, about what fraction of the circle will represent food expenses?

- [A] $\frac{1}{2}$ [B] $\frac{1}{3}$ [C] $\frac{1}{5}$ [D] $\frac{1}{10}$

42. Simplify: $\frac{2}{3} \times \frac{11}{12}$

- [A] $\frac{11}{18}$ [B] $\frac{13}{15}$ [C] $\frac{1}{2}$ [D] $\frac{8}{11}$

43. Evaluate $w - v$ if $w = 6\frac{2}{7}$ and $v = 4\frac{1}{14}$.

- [A] $\frac{25}{14}$ [B] $7\frac{6}{7}$ [C] $2\frac{1}{7}$ [D] $2\frac{3}{14}$

44. A set of encyclopedias would be measured by

- [A] milligrams [B] kilograms [C] liters [D] grams

45. What is the value of x in the parallelogram?

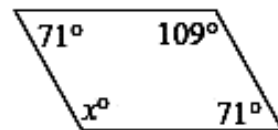

- [A] 71 [B] 109 [C] 92 [D] 130

46. A bag contains 6 different colored balls. Alberto picks 2 balls from the bag. How many different color combinations are possible?

[A] 6

[B] 12

[C] 15

[D] 30

47. Which is **closest** to the area of the shaded figure, in square units.

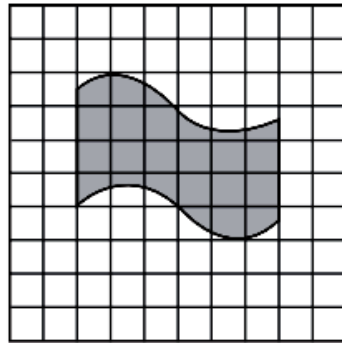

□ = 1 square unit

[A] 12 square units

[B] 18 square units

[C] 24 square units

[D] 30 square units

48. Each letter in the word CHATTAHOOCHEE is written on a separate piece of paper. Each piece of paper is the same size. The pieces of paper are put into a bag. One of the pieces of paper is selected from the bag at random.

What is the probability the letter on the first piece of paper selected will be a H?

[A] $\frac{2}{13}$

[B] $\frac{3}{13}$

[C] $\frac{6}{13}$

[D] $\frac{10}{13}$

49. Which transformation could result in the diagram?

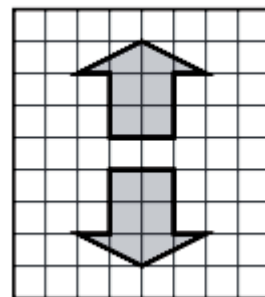

[A] Reflection or Translation

[B] Translation or Rotation

[C] Reflection or Rotation

[D] Rotation only

50. Rhonda's cheer team is making a photo collage for their team captain. They have photos in the sizes shown below.

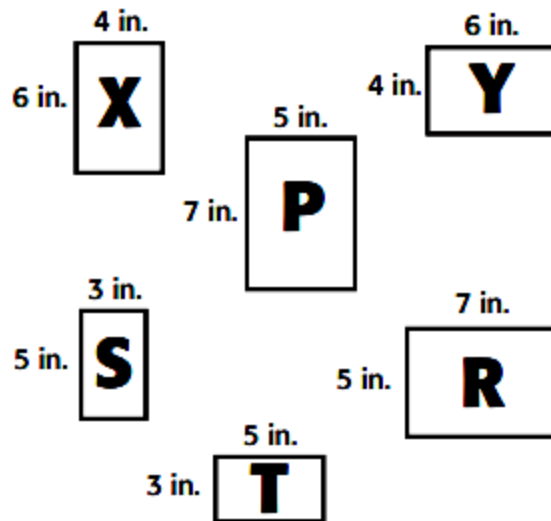

They will place the photos next to each other so that their edges are touching. They don't want any photos rotated, cut, or overlapping. Which two sets would NOT make rows of equal length?

[A]

First set	2 size R photos and 2 size S photos
Second set	5 size X photos

[B]

First set	2 size Y photos
Second set	4 size S photos

[C]

First set	2 size X photos and 1 size Y photo
Second set	4 size S photos

[D]

First set	6 size T photos
Second set	5 size Y photos

1. A	26. D
2. C	27. B
3. C	28. C
4. D	29. B
5. D	30. D
6. B	31. C
7. D	32. B
8. C	33. D
9. D	34. A
10. C	35. D
11. B	36. C
12. C	37. C
13. C	38. B
14. B	39. A
15. A	40. A
16. B	41. C
17. C	42. A
18. C	43. D
19. C	44. B
20. A	45. B
21. B	46. D
22. A	47. B
23. A	48. B
24. B	49. C
25. A	50. C

