

5th Grade Individual Test 2006

- Find the sum. $802 + 1326$ [A] 2028 [B] 9228 [C] 2128 [D] 9328
- Find the difference. $342.37 - 14.8$
[A] 327.57 [B] 3408.9 [C] 3275.7 [D] 357.17
- Find the product. 65×62 [A] 4030 [B] 2660 [C] 3930 [D] 3830

Find the quotient.

- $\frac{0.0216}{0.36}$ [A] 0.0006 [B] 0.06 [C] 0.6 [D] 6000
- $4088 \div 28$ [A] 141 [B] 140.96 [C] 146.03 [D] 146

6. Which expression represents $\left(\frac{4}{11}\right)^4$?

- [A] $\frac{4}{11} \times \frac{4}{11} \times \frac{4}{11} \times \frac{4}{11}$ [B] $\frac{16}{44} \times \frac{16}{44} \times \frac{16}{44} \times \frac{16}{44}$ [C] $4 \frac{4}{11}$ [D] $\frac{8}{15} \times \frac{8}{15} \times \frac{8}{15} \times \frac{8}{15}$

7. Simplify the expression. $27(90 - 10 \div 5) + 8 \cdot 5$

- [A] 2185 [B] 2470 [C] 2416 [D] 11,920

8. Evaluate $\frac{y}{3x} - z$ when $x = 3$, $y = 36$, and $z = 1$.

- [A] -11 [B] 3 [C] 5 [D] -8

9. The number of cars sold by type, per 100, is listed in the table. Use the table to answer the questions.

U.S. Car Sales by Vehicle Size and Type, 1991-1995

Year	Small	Midsize	Large	Luxury	Total
1991	33.0	44.9	8.3	13.9	100.0
1992	32.9	44.5	9.2	13.4	100.0
1993	32.8	43.3	11.1	12.8	100.0
1994	29.2	45.6	11.7	13.5	100.0
1995	27.1	48.5	10.8	13.6	100.0

How many more large cars per

100 were sold in 1992 than in 1991?

- [A] 0.09 [B] 9.0 [C] 17.5 [D] 0.9

10. The double-line graph compares rainfall, in centimeters, in Sydney and Canberra in March, 1993.

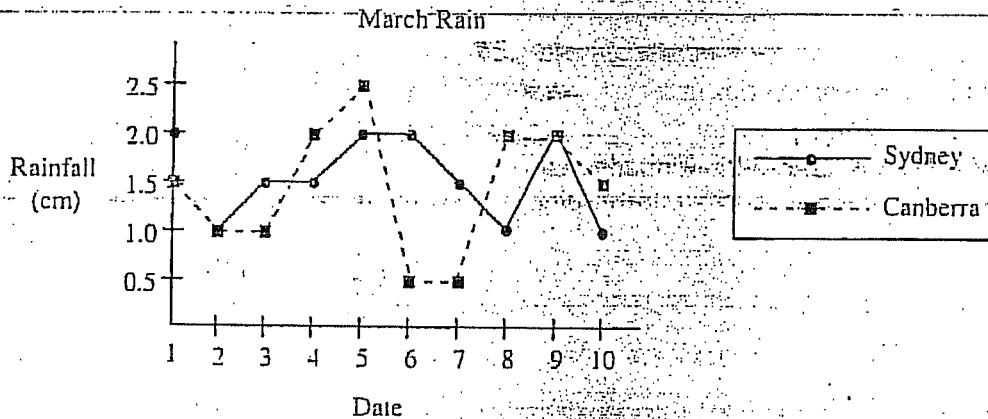

What was the date of the most rainfall in Canberra?

- [A] March 6 [B] March 10 [C] March 1 [D] March 5

11. What is the name of the polygon shown?

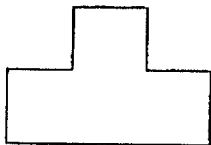

- [A] nonagon [B] octagon [C] pentagon [D] hexagon

12. How many dots will be in the fifth figure of this pattern?

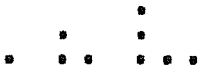

- [A] 7 [B] 13 [C] 11 [D] 9

13. Kaye runs a small business with three employees. She pays one employee \$2300 a month, another \$1600 a month, and the third \$1400 a month. How much does she pay her employees in a year?

- [A] \$62,400 [B] \$30,600 [C] \$63,600 [D] \$31,800

14. In an election between two candidates, 930 votes were cast. If the winner received 220 more votes than the loser, how many votes did the winner receive?

- [A] 355 votes [B] 575 votes [C] 1150 votes [D] 710 votes

15. Decide which information is necessary to solve the problem. Then solve the problem:

You sell and deliver newspapers in your neighborhood. You start each day at 7:00 a.m.

You earn \$0.07 per paper you deliver. You earn a \$5.00 bonus for every new subscription

you obtain for the company. This week you delivered 120 papers and obtained one new

subscription. You worked 1.5 hours each day. How much did you earn this week?

- [A] \$608.40 [B] \$6.27 [C] \$8.40 [D] \$13.40

16. Name the coordinates of the points A , B , C , and D .

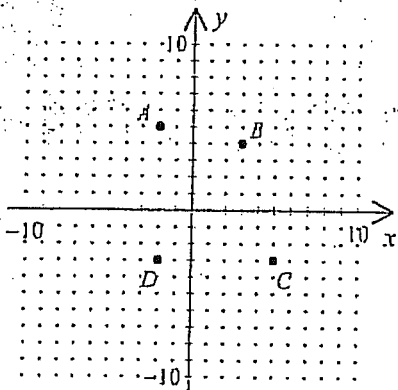

- [A] $A(5, -2)$, $B(4, 3)$, $C(-3, 5)$, $D(-3, -2)$ [B] $A(-2, 5)$, $B(3, 4)$, $C(5, -3)$, $D(-2, -3)$
 [C] $A(-2, 5)$, $B(4, 3)$, $C(5, -3)$, $D(-3, -2)$ [D] $A(5, -2)$, $B(3, 4)$, $C(-3, 5)$, $D(-2, -3)$

17. Estimate the area of the figure below. The area of each square is 16 cm^2 .

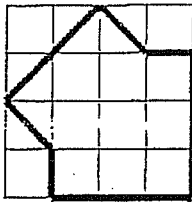

- [A] 181.5 cm^2 [B] 256 cm^2 [C] 184 cm^2 [D] 176 cm^2

18. Use the time line showing the life of George Washington.

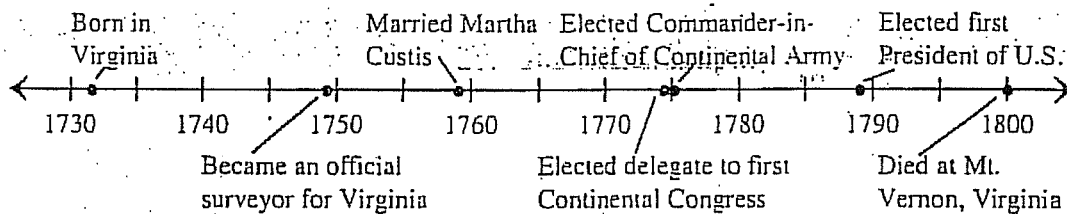

About how old was George Washington when he died?

- [A] about 77 [B] about 73 [C] about 63 [D] about 67

19. A bag contains 2 red, 5 white, and 6 blue marbles. Find the probability of obtaining a white or a blue marble in a single draw.

- [A] $\frac{7}{13}$ [B] $\frac{8}{13}$ [C] 1 [D] $\frac{11}{13}$

20. Use the spinner.

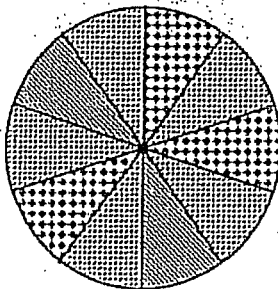

What is the probability that the spinner will land on a checkered section?

- [A] $\frac{1}{10}$ [B] $\frac{1}{9}$ [C] $\frac{9}{10}$ [D] $\frac{3}{10}$

21. Which number is divisible by 3 and by 8?

- [A] 939 [B] 312 [C] 2504 [D] 933

22. Which of the following numbers is prime? [A] 27 [B] 51 [C] 57 [D] 73

23. Simplify the fraction. $\frac{24}{36}$ [A] $\frac{5}{6}$ [B] $\frac{1}{6}$ [C] $\frac{6}{9}$ [D] $\frac{2}{3}$

24. Which of the following fractions is smallest? $\frac{13}{16}$, $\frac{2}{3}$, $\frac{1}{5}$, $\frac{1}{6}$

[A] $\frac{13}{16}$ [B] $\frac{1}{5}$ [C] $\frac{2}{3}$ [D] $\frac{1}{6}$

25. Add. Then simplify. $\frac{5}{10} + \frac{9}{10}$ [A] $2\frac{4}{5}$ [B] $1\frac{2}{5}$ [C] $\frac{7}{10}$ [D] $1\frac{1}{5}$

Subtract. Then simplify.

26. $5\frac{6}{11} - 2\frac{4}{11}$ [A] $4\frac{2}{11}$ [B] $3\frac{9}{11}$ [C] $3\frac{2}{11}$ [D] $2\frac{2}{11}$

27. $\frac{5}{6} - \frac{7}{12}$ [A] $\frac{5}{18}$ [B] $\frac{1}{2}$ [C] $\frac{19}{72}$ [D] $\frac{1}{4}$

28. Frank has three packages of seeds. One of the packages contains 8 ounces, one contains $\frac{2}{3}$ ounces, and one contains $4\frac{2}{3}$ ounces. How many ounces of seeds does Frank have in all?

[A] $13\frac{1}{3}$ oz [B] $10\frac{1}{4}$ oz [C] 10 oz [D] $13\frac{7}{18}$ oz

29. There is a ratio of 33 players for every 2 coaches. If there are 8 coaches, how many players are there?

[A] 132 players [B] 4 players [C] 264 players [D] NG

30. Find the area of the figure.

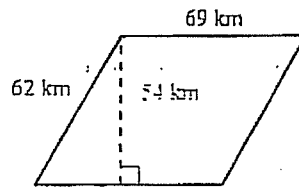

- [A] 4002 km^2 [B] 4278 km^2 [C] 3537 km^2 [D] 3726 km^2

31. If $\triangle ABC \cong \triangle DEF$, $AB = 4$ feet, $m\angle B = 39^\circ$, and $m\angle F = 17^\circ$, which of the following statements is false?

- [A] $\angle C \cong \angle F$ [B] $CA = DF$ [C] $AB = ED$ [D] $m\angle E = 124^\circ$

32. The two rectangular rooms shown below are congruent. The architect did not finish the diagrams. Find the missing side lengths and angle measures.

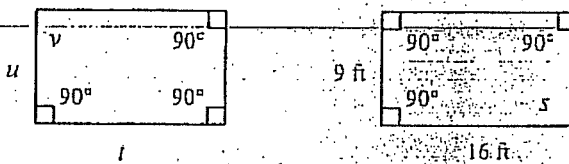

- [A] $s = 16 \text{ ft}; t = 9 \text{ ft}; u = 90^\circ; v = 90^\circ$ [B] $s = 90^\circ; t = 16 \text{ ft}; u = 9 \text{ ft}; v = 90^\circ$
 [C] $s = 90^\circ; t = 9 \text{ ft}; u = 16 \text{ ft}; v = 90^\circ$ [D] $s = 16 \text{ ft}; t = 90^\circ; u = 9 \text{ ft}; v = 90^\circ$

33. Find the volume of the prism.

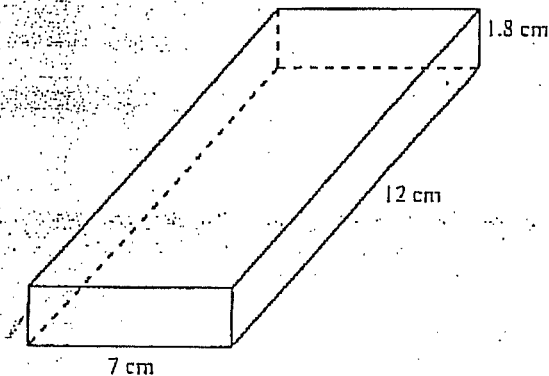

- [A] 151.2 cm^3 [B] 105.6 cm^3 [C] 83.2 cm^3 [D] 118.2 cm^3

34. Write an algebraic model of the situation. An amusement park charges \$7.00 admission and \$2.00 per ride.

- [A] $y = 2x + 7$ [B] $y = -2x + 7$ [C] $y = 7x + -2$ [D] $y = 7x + 2$

35. Find the area of a circle with radius 12 cm. Use $\pi = 3.14$.

- [A] 452.16 cm^2 [B] 904.32 cm^2 [C] 75.36 cm^2 [D] 226.08 cm^2

36. Find the area of the quadrilateral. (not drawn to scale)

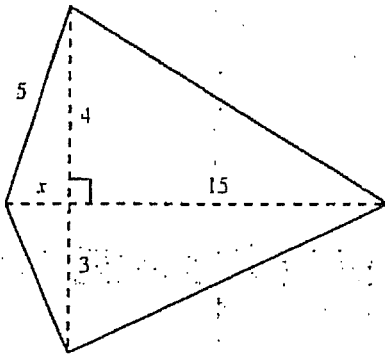

[A] 67

[B] 126

[C] 12

[D] 63

37. Write 3213 in expanded notation.

[A] $(3 \times 10000) + (2 \times 1000) + (1 \times 100) + (3 \times 10)$

[B] $(3 \times 10000) + (2 \times 1000) + (3 \times 100) + (1 \times 10)$

[C] $(3 \times 1000) + (2 \times 100) + (3 \times 10) + (1 \times 10)$

[D] $(3 \times 1000) + (2 \times 100) + (1 \times 10) + 3$

38. What is the described number? $3 \times 100,000 + 6 \times 10,000 + 4 \times 100 + 5 \times 1$

[A] 364,500

[B] 360,045

[C] 306,405

[D] 360,405

39. Write 34.771 in expanded notation.

[A] $(3 \times 10) + (4 \times 1) + (77 \times 0.01) + (1 \times 0.001)$

[B] $34 + (771 \times 0.001)$ [C] $34 + (7 \times 0.1) + (7 \times 0.01) + (1 \times 0.001)$

[D] $(3 \times 10) + (4 \times 1) + (7 \times 0.1) + (7 \times 0.01) + (1 \times 0.001)$

40. Convert 656 centimeters to meters.

[A] 0.656 m

[B] 6560 m

[C] 65,600 m

[D] 6.56 m

41. Round each decimal to the given decimal place. 2.0526 (thousandths)

[A] 2.05

[B] 2.1

[C] 2.052

[D] 2.053

42. Multiply: 0.547×0.18 [A] 0.009846 [B] 98.46 [C] 0.09846 [D] 9.846

43. What numbers are represented by the stem-and-leaf plot below?

7		5	6	9
8		1	3	4
9		2	9	

[A] 57, 67, 97, 18, 38, 48, 29, 99

[B] 12, 13, 16, 9, 11, 12, 11, 18

[C] 75, 76, 79, 81, 83, 84, 92, 99

[D] 5, 6, 9, 1, 3, 4, 2, 9

44. So far in Spanish class, your test scores are 87, 88, 83, and 76. What score do you need on the fifth test to get an average or mean of 85?

[A] 91

[B] 92

[C] 83.5

[D] 89

45. Which fraction would make the statement $\frac{3}{5} < \bigcirc$ true?

[A] $\frac{2}{5}$

[B] $\frac{1}{3}$

[C] $\frac{3}{4}$

[D] $\frac{1}{2}$

46. How long is the black strip to the nearest quarter inch?



[A] $1\frac{1}{2}$ in.

[B] 7 in.

[C] 2 in.

[D] $1\frac{3}{4}$ in.

47. Convert 5 yards to inches. [A] 63 in. [B] 60 in. [C] 15 in. [D] 180 in.

48. Which statement is FALSE?

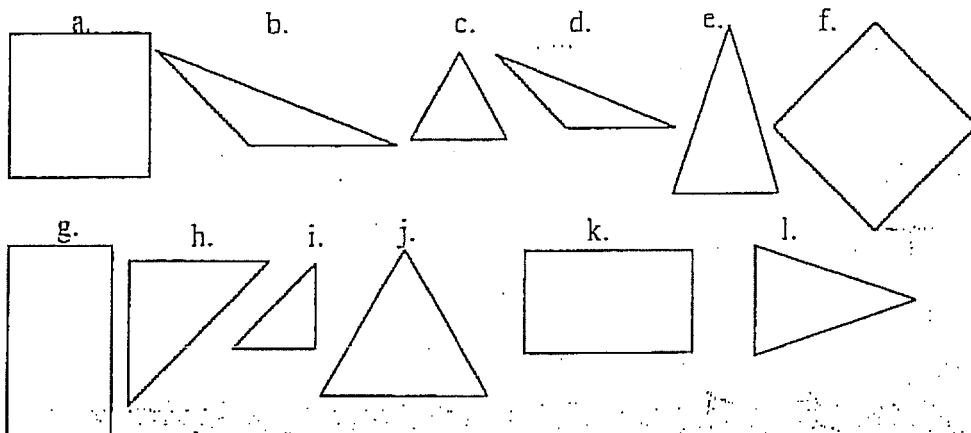

[A] h and i are similar.

[B] g and k are similar.

[C] b and d are similar.

[D] f and g are congruent.

49. Find the measure of angle x.

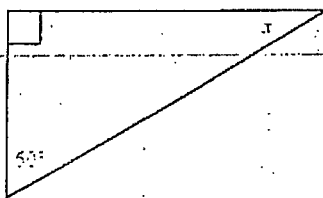

[A] 70°

[B] 90°

[C] 30°

[D] 50°

50. Grade 7 students were surveyed to determine how many hours a day they spent, on average, on various activities. The results are shown in the circle graph below. About how much time altogether was spent on socializing and school?

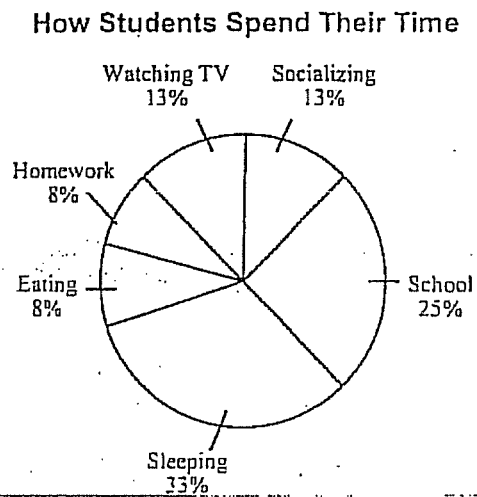

[A] 6 h

[B] 9 h

[C] 38 h

[D] 12 h

Southeast Bulloch High School Fifth & Sixth Grade Mathematics Tournament
April 8, 2006
Fifth Grade Division Item Analysis

Number	Answer	Percent Correct
1.	C	99%
2.	A	79%
3.	A	93%
4.	B	43%
5.	D	78%
6.	A	91%
7.	C	30%
8.	B	54%
9.	D	70%
10.	D	95%
11.	B	49%
12.	D	58%
13.	C	78%
14.	B	33%
15.	D	65%
16.	B	63%
17.	D	70%
18.	D	52%
19.	D	80%
20.	D	99%
21.	B	72%
22.	D	26%
23.	D	89%
24.	D	64%
25.	B	88%
26.	C	91%
27.	D	93%
28.	A	83%
29.	A	63%
30.	D	36%
31.	D	32%
32.	B	83%
33.	A	60%
34.	A	44%
35.	A	19%
36.	D	23%
37.	D	90%
38.	D	64%
39.	D	49%
40.	D	53%
41.	D	64%
42.	C	68%
43.	C	79%
44.	A	30%
45.	C	70%
46.	D	77%
47.	D	73%
48.	D	73%
49.	C	72%
50.	B	27%