

Borough of Audubon



TELEPHONE: (856) 547-0710
FAX: (856) 546-4749

606 W. NICHOLSON ROAD
AUDUBON, NEW JERSEY 08106

FIRE INSPECTION REQUIREMENTS SALE OF PROPERTY

There must be a working smoke detector in every bedroom. They must be a new, sealed, 10-year battery, smoke detector. Must be UL Approved/Certified.

Outside of every bedroom within 10 feet, there must be a new, sealed, 10-year battery, smoke detector and carbon monoxide detector. It can be a combination carbon monoxide/smoke detector.

There must be a smoke detector in the basement, attic and on the first floor by the steps going up to the second floor.

There must be a 2A-10BC fire extinguisher (no more than 5 lbs.) in the kitchen purchased within the last year. Please provide the receipt or an inspection must be performed on the fire extinguisher with the tags.

Your house numbers for your address must be visible from the street.

BOROUGH of AUDUBON - OFFICE of the FIRE MARSHAL
REQUIREMENTS FOR SMOKE DETECTOR, CARBON MONOXIDE DETECTOR & FIRE EXTINGUISHER COMPLIANCE

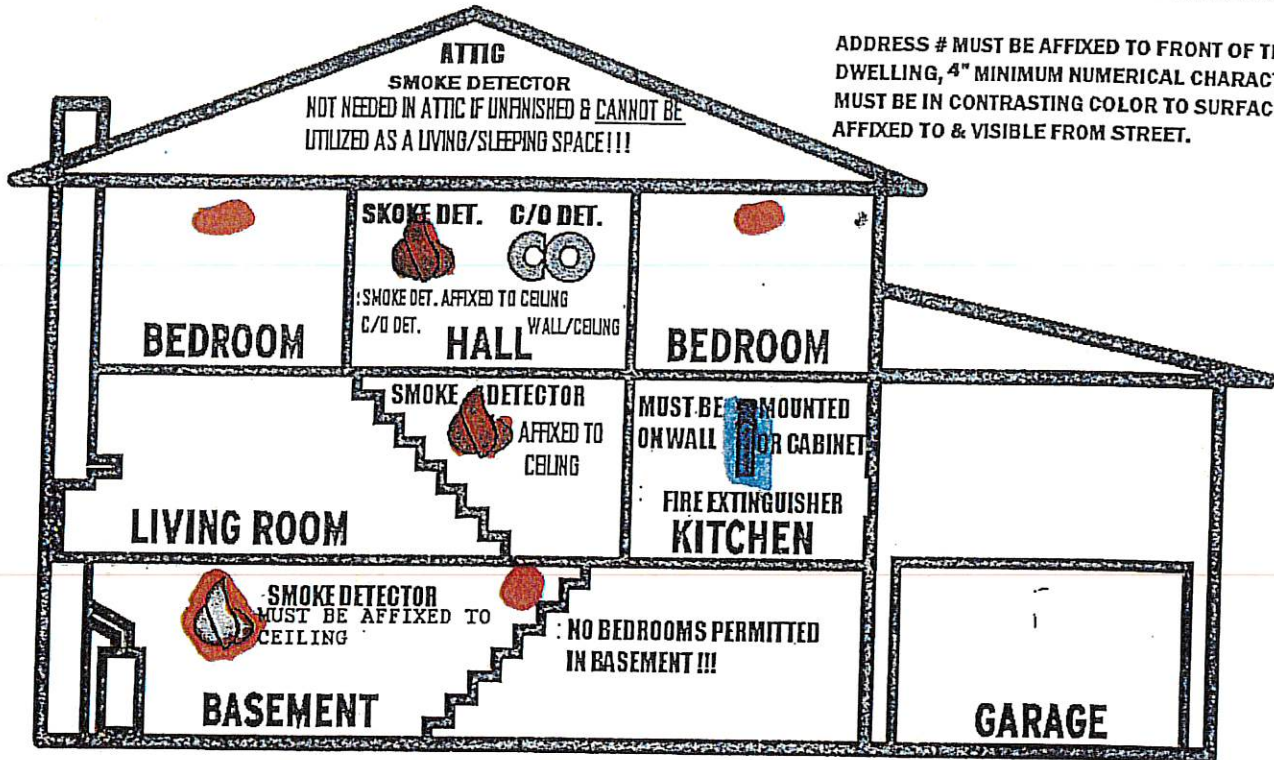

ADDRESS # MUST BE AFFIXED TO FRONT OF THE DWELLING, 4" MINIMUM NUMERICAL CHARACTERS & MUST BE IN CONTRASTING COLOR TO SURFACE BEING AFFIXED TO & VISIBLE FROM STREET.



Smoke Alarm
Carbon Monoxide Alarm



Fire Extinguisher

ADDRESS

Diagrams

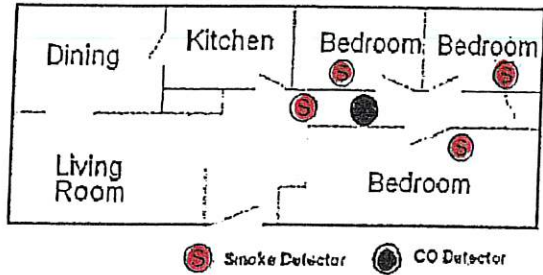

Figure 1

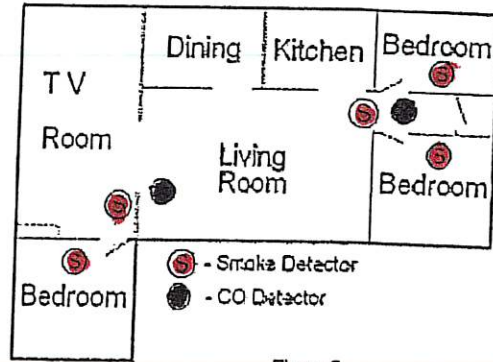

Figure 2

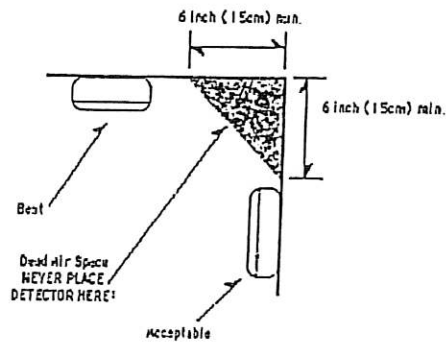

Figure 3

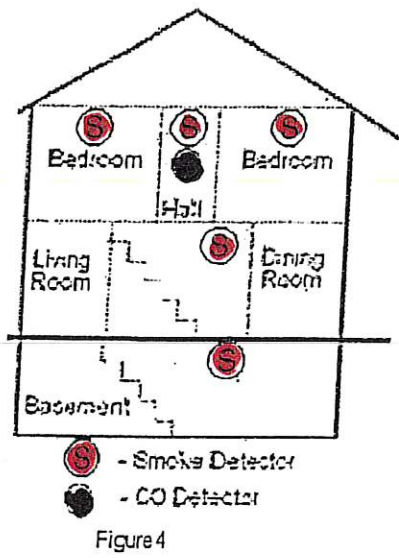

Figure 4

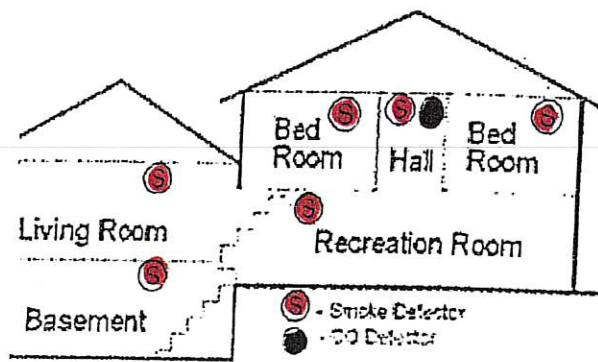

Figure 5