

MONROE CAREER &
TECHNICAL INSTITUTE

Program Guide

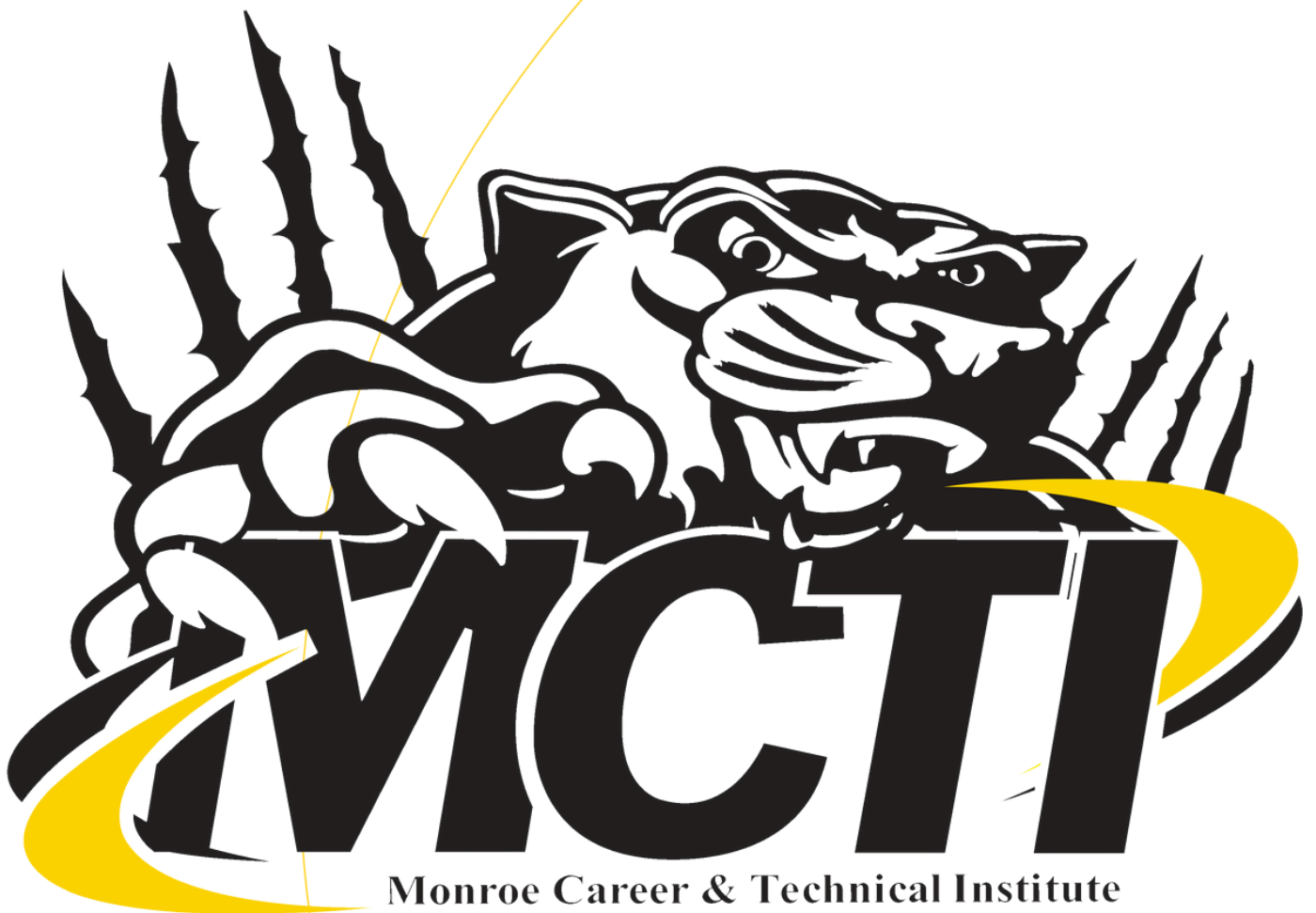

Monroe Career & Technical Institute

PROFESSIONAL EXCELLENCE IN CAREER AND TECHNICAL
TRAINING TODAY FOR A SUCCESSFUL TOMORROW.

MCTI is an extension of the four school districts of Monroe County and provides tuition-free career and technical education for high school students. Students in grades 10 - 12 attend a half-day at MCTI and a half-day at their sending high school. MCTI also offers a full-day program for 9th grade students.

An MCTI education provides students with more opportunities to learn practical skills using state-of-the-art equipment, develop leadership skills, obtain industry credentials, and earn college credits all while gaining real-world experiences.

SENDING SCHOOL DISTRICTS



**East Stroudsburg Area
School District**



**Pleasant Valley
School District**



**Pocono Mountain
School District**



**Stroudsburg Area
School District**



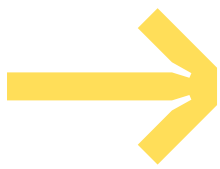

PROGRAMS

MCTI offers students 24 Pennsylvania Department of Education (PDE) approved programs that articulate a secondary career and technical education to a postsecondary degree, diploma, or certificate programs. These programs align the secondary courses to a postsecondary program to complete a degree or certificate. Our programs are divided into the following five Career Clusters:



TRANSPORTATION

Automotive Collision Repair.....	1
Automotive Technology.....	2
Diesel Technology.....	3
Outdoor Power Equipment Technology.....	4



CONSTRUCTION

Carpentry.....	5
Electrical Technology.....	6
HVAC Technology.....	7
Masonry.....	8
Plumbing.....	9



ENGINEERING TECHNOLOGY

Drafting & Design Technology.....	10
Electronics Technology.....	11
Precision Machining.....	12
Welding Technology.....	13



COMMUNICATIONS

Computer Information Science.....	14
Computer Networking & Security.....	15
Graphic Communications.....	16



SERVICE

Business and Hospitality Management.....	17
Cosmetology.....	18
Criminal Justice.....	19
Culinary Arts.....	20
Health Professions.....	21
Horticulture.....	22
Therapeutic Science/Sports Medicine.....	23
Diversified Occupations.....	24



AUTOMOTIVE COLLISION REPAIR

47.0603 AUTOBODY/COLLISION AND REPAIR TECHNOLOGY/TECHNICIAN
(PDE APPROVED PROGRAM OF STUDY)



The Auto Collision Repair Program prepares students to apply technical knowledge and skills to repair damaged vehicles, such as automobiles and light trucks. Students learn to examine damaged vehicles and estimate repair costs; repair and replace upholstery, accessories, electrical and hydraulic windows and seat operating equipment. They are instructed on how to remove trim to gain access to vehicle body and fenders; remove and replace glass; repair dented areas; replace excessively damaged fenders, panels and grills; straighten bent frames or unibody structures using hydraulic jacks and pulling devices; and file, grind and sand repaired surfaces using power tools and hand tools.

CAREER PATHS

- Automobile Body and Related Repairers
- Helpers-Installation, Maintenance and Repair Workers
- Automotive Specialty Technicians
- Painters, Transportation Equipment



According to I-CAR, nearly half of entry-level technicians hired are selected from career or technical school programs.

INDUSTRY CREDENTIALS

Students can earn the following industry-recognized credentials:

- S/P2 Automotive Certification via S/P2
- I-CAR, various levels via I-CAR



AUTOMOTIVE TECHNOLOGY

47.0604 AUTOMOBILE/AUTOMOTIVE MECHANICS TECHNOLOGY/TECHNICIAN
(PDE APPROVED PROGRAM OF STUDY)

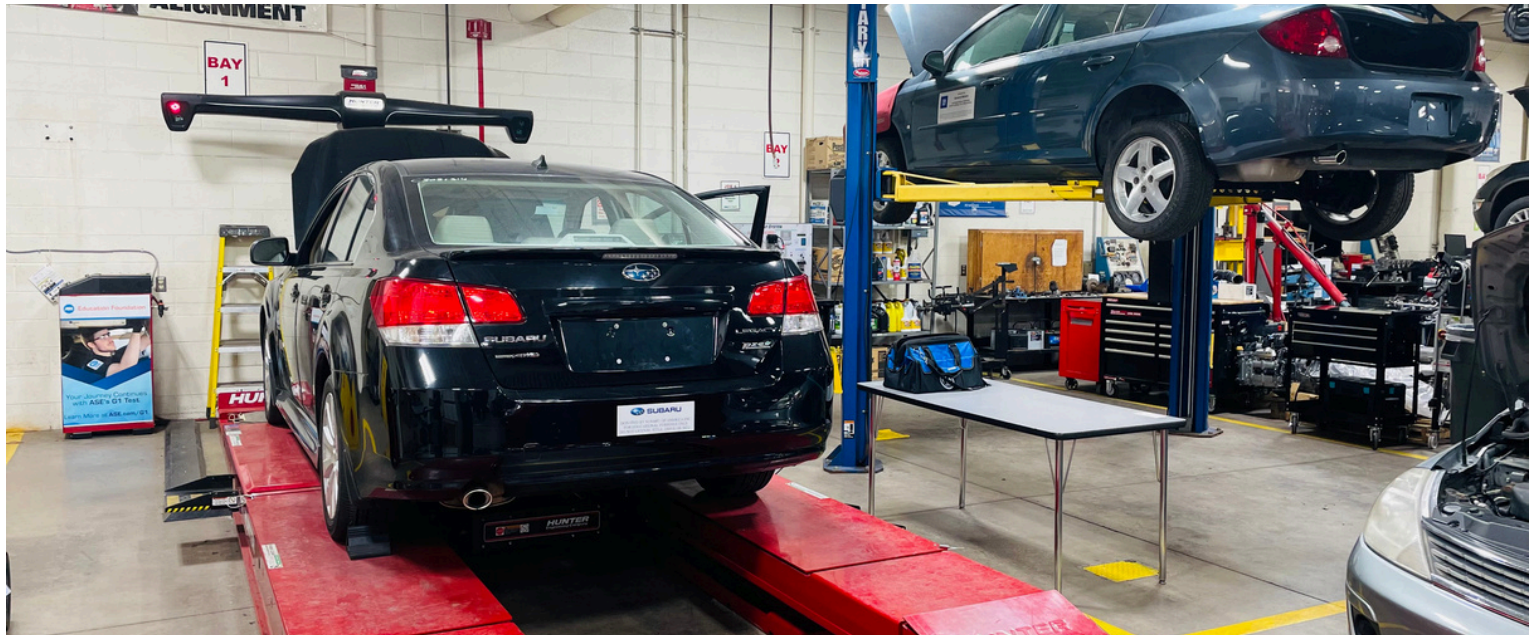

The Automotive Technology Program prepares students to apply technical knowledge and skills to engage in the servicing and maintenance of all types of automobiles and light trucks. Students will learn to diagnosis malfunctions in engines, fuel, electrical, brake systems, as well as drive trains and suspension systems. Testing to repair these malfunctions may include computer analysis. Instruction is also given in the adjustment and repair of individual components and systems such as cooling systems, fuel system components and air conditioning using technical repair information, and state inspection procedures.

This program is certified by the National Automotive Technicians Education Foundation (NATEF). Automotive technicians need knowledge of electronics, emission control, electricity, mechanics, and hydraulics.

The need for skilled technicians is rapidly increasing. Expanded use of electronics, new government requirements on safety and pollution control, and more extensive warranties on new vehicles require the work of highly skilled technicians and diagnosticians.

Alternate fuels and hybrid vehicles mass production will create 150,000 new jobs. For the next few years, production of hybrid cars will grow to about 5.4 million units.

CAREER PATHS

- Automotive Service Technician and Mechanic
- Automotive Specialty Technician
- Administrative Service Manager

INDUSTRY CREDENTIALS

Students can earn the following industry-recognized credentials:

- S/P2 Automotive Certification via S/P2
- Certified Safety Inspector, Cat I via PA Dept. of Transportation
- Section 609 Certification for Refrigerant, Recycling and Recovery via Mobile Air Conditioning Society Worldwide
- ASE via Automotive Service Excellence
- Battery Starting and Charging System via AC Delco
- Electrical State 1 & 2 via AC Delco
- AYES Certificate via Automotive Youth Educational System
- Motor Oil Certification via Valvoline



DIESEL TECHNOLOGY

47.0613 MEDIUM/HEAVY VEHICLE AND TRUCK TECHNOLOGY/TECHNICIAN
(PDE APPROVED PROGRAM OF STUDY)



The Diesel Technology Program is designed to prepare students to apply technical knowledge and skills to the specialized maintenance and repair of trucks, buses, and other commercial and industrial vehicles. This program includes instruction in diesel engine mechanics, suspension and steering, brake systems, electrical and electronic systems, preventive maintenance inspections, drive trains, HVAC systems, and auxiliary equipment installation and repair.

The Diesel Technology Program includes safety, theory, and general practice. Diesel technicians must like to work with machines and be able to use both hand and power tools. This program is certified by the National Automotive Technicians Education Foundation (NATEF).



On average, approximately 28,000 openings for diesel service technicians and mechanics have been projected each year over this decade.

CAREER PATHS

- Bus and Truck Mechanic
- Diesel Engine Specialist
- Industrial Machinery Mechanic
- Automotive Master Mechanic
- Helpers-Installation
- Farm Equipment Mechanic

INDUSTRY CREDENTIALS

Students can earn the following industry-recognized credentials:

- S/P2 Automotive Certification via S/P2
- Certified Safety Inspector, Cat I via Pennsylvania Department of Transportation
- Section 609 Certification for Refrigerant Recycling and Recovery via National Institute for Automobile Service Excellence
- Get Ahead via Daimler Trucks North America



OUTDOOR POWER EQUIPMENT TECHNOLOGY

47.0699 VEHICLE MAINTENANCE AND REPAIR TECHNOLOGIES, OTHER
(PDE APPROVED CAREER TECH PROGRAM)



The Power Equipment Technologies Program prepares students to apply technical knowledge and skills to repair, service, maintain and diagnose problems on a variety of small internal-combustion gasoline engines and related systems used on portable power equipment such as lawn and garden equipment, chain saws, outboard motors, rototillers, snowmobiles, lawn mowers, motorcycles, personal watercraft and pumps and generators. Students are instructed in the principles of the internal-combustion engine and all systems related to the powered unit. Instruction also includes the use of technical and service manuals, state inspection code, care and use of tools and test equipment, engine tune-up/maintenance, engine overhaul, troubleshooting and diagnostic techniques, drive lines and propulsion systems, electrical and electronic systems, suspension and steering systems and service operations and parts management.

According to the U.S. Bureau of Labor Statistics, overall employment of small engine mechanics is projected to grow 9 percent or approximately 8300 jobs each year. The global powersports market is projected to grow from \$8.76 billion to \$12.75 billion over the next five years.

CAREER PATHS

- Engine Repair Technician
- Gas-Engine Technician
- Power-Saw Mechanic
- Small-Engine Mechanic
- Motorboat Mechanics and Service Technician
- Motorcycle Mechanic

INDUSTRY CREDENTIALS

Students can earn the following industry-recognized credentials:

- S/P2 Automotive Certification via S/P2
- S/P2 Safety and Pollution Prevention via S/P2
- OSHA Certification via CareerSafe
- Outdoor Power Equipment Technician Certification via Equipment & Engine Training Council
- Master Service Technician via Briggs and Stratton Corporation
- STIHL MasterWrench Service Technician-Bronze via STIHL



CARPENTRY

46.0201 CARPENTRY/CARPENTER
(PDE APPROVED PROGRAM OF STUDY)



The Carpentry Program prepares students to apply technical knowledge and skills to lay out, fabricate, erect, install and repair structures and fixtures using hand and power tools. This program includes instruction in common systems of framing, construction materials, estimating, blueprint reading and finish carpentry techniques. Students are taught with a combination of classroom theory and hands-on building experience in residential, commercial, and industrial construction trades.

Employment of carpenters is projected to grow 8% over the next five years, being one of the fastest growing occupations. Population growth may result in more new-home construction—one of the largest segment employing carpenters—which will require many new workers.



CAREER PATHS

- Rough Carpenter
- Carpenter Helper
- Roofer
- Drywaller

INDUSTRY CREDENTIALS

Students can earn the following industry-recognized credentials:

- OSHA Certification via CareerSafe
- Pennsylvania Builders Association Skills Certificate via Pennsylvania Builders Association
- Articulated Ladder via American Ladder Institute
- Mobile Ladder via American Ladder Institute
- Single and Extension Ladder via American Ladder Institute
- Step Ladder via American Ladder Institute



ELECTRICAL TECHNOLOGY

46.0399 ELECTRICAL AND POWER TRANSMISSION INSTALLERS, OTHER
(PDE APPROVED PROGRAM OF STUDY)

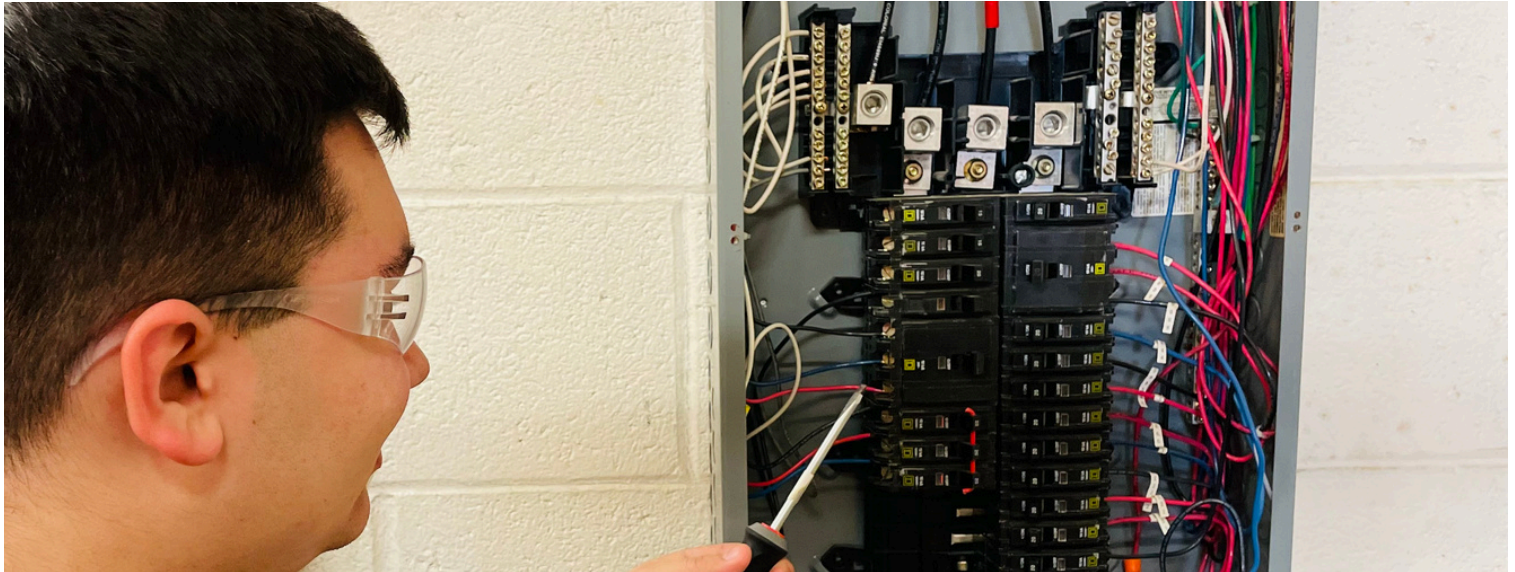

The Electrical Technology Program prepares students to apply technical knowledge and skills necessary to install, operate, maintain and repair electrically-energized residential, commercial and industrial systems, and DC and AC motors, controls and electrical distribution panels. Instruction emphasizes practical application of mathematics, science, circuit diagrams and use of electrical codes and includes blueprint reading, sketching and other subjects essential for employment in the electrical occupations. Reading and interpretation of commercial and residential construction wiring codes and specifications, installation and maintenance of wiring, service and distribution networks within large construction complexes are also critical components of the program.

Students are given the opportunity to pursue advanced training in motor control circuits and power technology applications. Students are also afforded the opportunity to study home automation by using the Smart Home Technology and receive practical experience by completing many projects.



America will face a shortage of electricians in the near future, according to the U.S. Bureau of Labor Statistics (BLS) and the National Electrical Contractors Association (NECA). The trade group says that 7,000 electricians join the field each year, but 10,000 retire. The BLS reports that employment of electricians is projected to grow 10% over the next five to seven years— making it one of the fastest growing occupations.

CAREER PATHS

- Electrician Helper
- Electrician, Apprentice
- First Line Supervisor and Manager
- Electric Motor and Switch Assembler and Repairer

INDUSTRY CREDENTIALS

Students can earn the following industry-recognized credentials:

- OSHA Certification via CareerSafe
- Pennsylvania Builders Association Skills Certificate via Pennsylvania Builders Association
- Articulated Ladder via American Ladder Institute
- Mobile Ladder via American Ladder Institute
- Single and Extension Ladder via American Ladder Institute
- Step Ladder via American Ladder Institute



HVAC TECHNOLOGY

**47.0201 HEATING, AIR CONDITIONING, VENTILATION
AND REFRIGERATION MAINTENANCE TECHNOLOGY/TECHNICIAN
(PDE APPROVED PROGRAM OF STUDY)**



The Heating, Ventilation & Air Conditioning (HVAC) Program combines classroom and practical learning experiences. This program prepares students to apply technical knowledge and skills to install, repair and maintain commercial and domestic heating, air conditioning and refrigeration systems. Instruction includes theory and application of basic principles involved in conditioning of air (cooling and heating); filtering and controlling humidity; operating characteristics of various units and parts; blueprint reading; use of technical reference manuals; the diagnosis of malfunctions; overhaul, repair and adjustment of units and parts such as pumps, compressors, valves, springs and connections; and repair of electric/electronic and pneumatic control systems.

CAREER PATHS

- Helpers- Installation, Maintenance, and Repair Workers
- Refrigeration Mechanic
- Air Conditioning and Heating Mechanics
- First Line Supervisors of Production and Operating Workers
- Stationary Engineer



HVAC's massive compound annual growth rate of about 4% will reach an estimated market size of \$370 billion by 2030.

INDUSTRY CREDENTIALS

Students can earn the following industry-recognized credentials:

- OSHA Certification via CareerSafe
- PBA Skills Certificate via Pennsylvania Builders Association
- EPA 608 Certification via Air Conditioning, Heating & Refrigeration Institute



MASONRY

46.0101 MASON/MASONRY
(PDE APPROVED PROGRAM OF STUDY)



The Masonry Program prepares students to apply technical knowledge and skills in the laying and/or setting of brick, concrete block, glass block, hard tile, marble and related materials using trowels, levels, hammers, chisels and other hand tools. The masonry curriculum combines classroom and practical learning experience including projects. There are several essential qualities to succeed at becoming a mason. Masons must regularly lift very heavy equipment and materials, such as blocks that weigh more than 40 pounds. Manual dexterity is also essential to applying smooth, even layers of mortar and quickly set bricks. Masons must have creativity to cut and shape masonry units into attractive and functional structures. They must also have the ability to read and comprehend blueprints, plans and instructions including safety policies and procedure manuals.

CAREER PATHS

- Brickmasons and Blockmasons
- Stonemasons
- Tile and Marble Setters
- Segmental Pavers
- Cement Mason and Concrete Finishers
- First-line Supervisors and Managers/Supervisors- Construction Trade Workers



Masonry is one of the oldest of the skilled trades. It dates back to the use of sunbaked clay brick more than 6,000 years ago; stone masonry dates back even further.

INDUSTRY CREDENTIALS

Students can earn the following industry-recognized credentials:

- OSHA Certification via CareerSafe
- Pennsylvania Builders Association Skills Certificate via Pennsylvania Builders Association



PLUMBING

46.0503 PLUMBING TECHNOLOGY/PLUMBER
(PDE APPROVED PROGRAM OF STUDY)

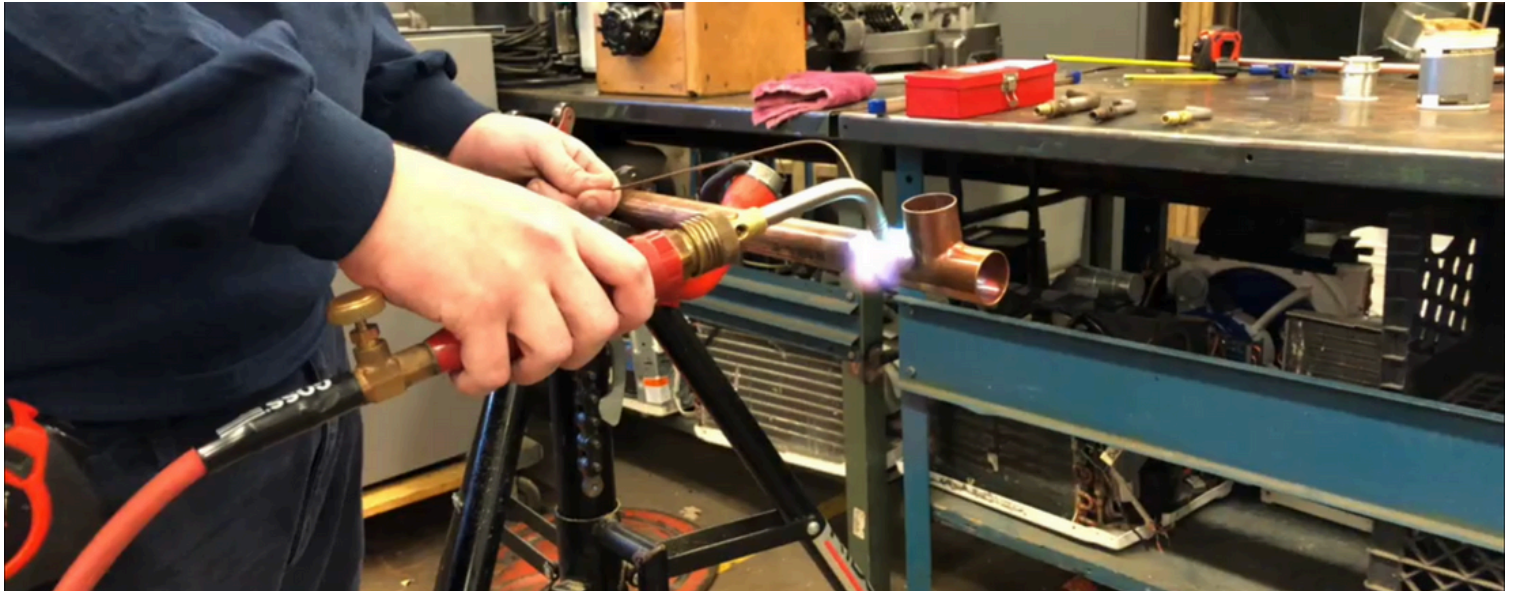

Plumbing Technology prepares students to practice as licensed plumbers by applying technical knowledge, safety and skills to lay out, assemble, install and maintain plumbing fixtures and systems for steam, natural gas, oil, hot water, heating, cooling, drainage, lubricating, sprinkling and industrial processing systems in home and business environments. The program includes instruction in source determination, water distribution, waste removal, pressure adjustment, basic physics, technical mathematics, blueprint reading, pipe installation, pumps, brazing and soldering, plumbing inspection and applicable codes and standards.

The program combines classroom and practical learning experiences. Students also become involved with many community service projects related to their program of study. This program is certified by the National Center for Construction Education and Research.

Over the next 10 years, it is expected that 81,900 plumbers will be needed; this includes 75,200 additional plumbers, and the retirement of 6,700 existing plumbers. According to the Bureau of Labor Statistics, plumbing related jobs are projected to grow by 16% in the coming years, much faster than average.



CAREER PATHS

- Pipefitter and Steamfitter Plumbers
- Plumber
- Heating and Air Conditioning Mechanics
- First Line Supervisor Managers and Mechanics, Installers and Repairers

INDUSTRY CREDENTIALS

Students can earn the following industry-recognized credentials:

- OSHA Certification via CareerSafe
- PBA Skills Certificate via Pennsylvania Builders Association
- EPA 608 Certification via Air Conditioning, Heating & Refrigeration Institute



DRAFTING & DESIGN TECHNOLOGY

15.1301 DRAFTING AND DESIGN TECHNOLOGY/TECHNICIAN, GENERAL
(PDE APPROVED PROGRAM OF STUDY)

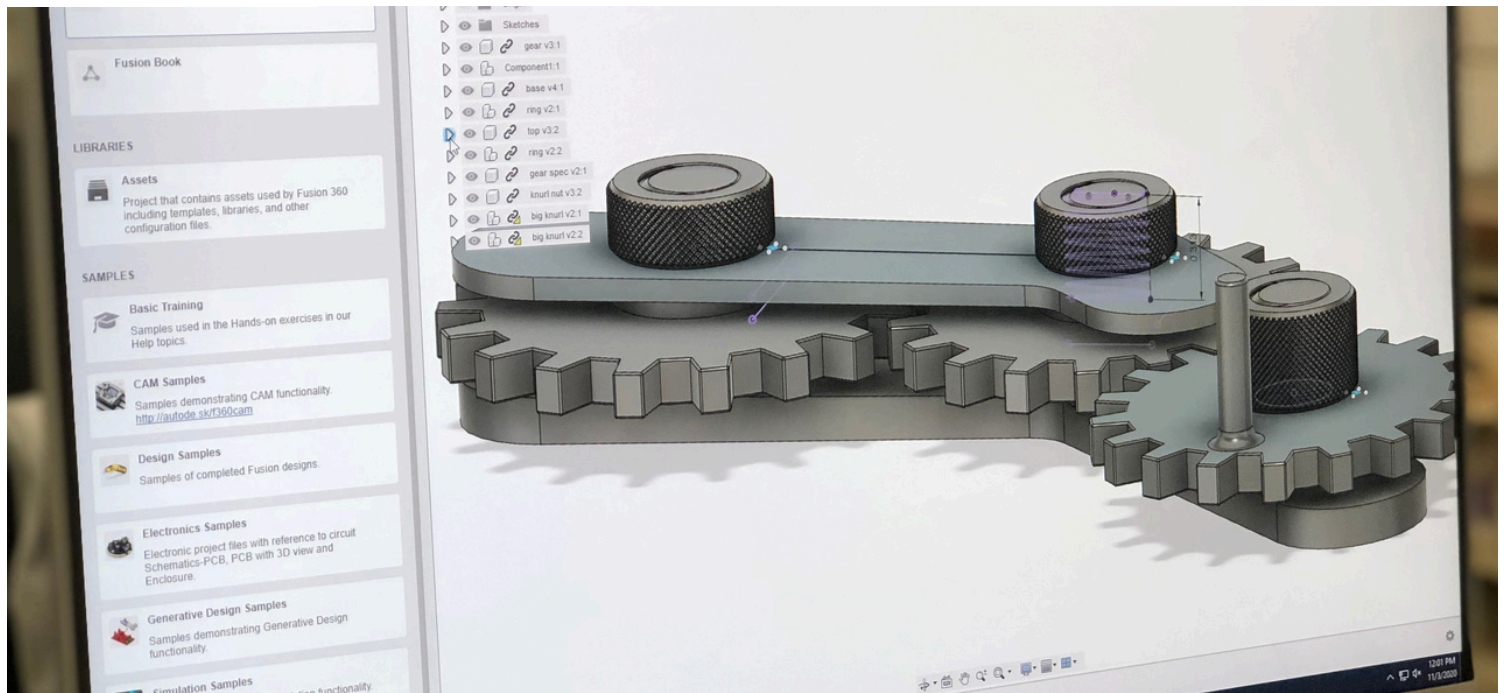

Drafting & Design Technology prepares students to apply technical knowledge and skills as each relates to gathering and translating of data or specifications including basic aspects of planning, preparing and interpreting mechanical, architectural, structural, civil, electrical/electronic, topographical and other drawings and sketches used in various engineering fields. Instruction is designed to provide experiences in drawing and Computer Aided Design (CAD); the use of reproduction materials, equipment and processes; the preparation of reports and data sheets for writing specifications; the development of plan and process charts indicating dimensions, tolerances, fasteners, joint requirements and other engineering data; the development of models; and drafting multiple view assembly and sub-assembly drawings as required for manufacture, construction and repair of mechanisms.

Students who successfully complete the program will have the opportunity to work as entry level CAD-technicians with mechanical, architectural, and civil drafting professionals. Students may also work in many related careers such as surveying, construction estimating, and specification writing.



Many MCTI Drafting & Design alumni are enrolled in higher education programs such as design, architecture, teaching and mechanical engineering.

CAREER PATHS

- Mechanical Drafter
- Architectural Drafter
- Civil Drafter
- Interior Designer
- Engineering

INDUSTRY CREDENTIALS

Students can earn the following industry-recognized credentials:

- OSHA Certification via CareerSafe
- Autodesk Certified User via Autodesk



ELECTRONICS TECHNOLOGY

15.0303 ELECTRICAL, ELECTRONIC AND COMMUNICATIONS,
ENGINEERING TECHNOLOGY/TECHNICIAN
(PDE APPROVED PROGRAM OF STUDY)



Electronics Technology prepares students to apply basic electronic principles and technical skills to the production, calibration, estimation, testing, assembling, installation and maintenance of electronic equipment. Emphasis is on passive components and solid-state devices; digital circuits; optoelectronic devices; operational amplifiers; audio and RF amplifiers; oscillators; power supplies; and AM, FM and PCM modulators. Knowledge is acquired through theoretical instruction, experimentation and hands-on activities. Instruction will develop basic levels of knowledge, understanding and associated skills essential for entry-level employment in communications, industrial electronics, digital processing, robotics, avionics, biomedical technology and other electronics occupations. Through collaborative curriculum planning with colleges and trade schools, students who participate in this program are eligible to obtain up to 12 credits advanced standing in a post-secondary program.

CAREER PATHS

- Production Repairer
- Electronic Assembler
- Electrical & Electronic Technicians
- Communication Technician
- Electronic Engineer
- Electrical & Electronic Drafters
- Electro-Mechanical Technicians

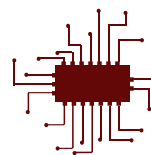

Electrical and electronics engineers are among the best paid in the field, earning between \$94,210 and \$99,210. The projected growth rate for both occupations is about 7% each year.

INDUSTRY CREDENTIALS

Students can earn the following industry-recognized credentials:

- OSHA Certification via CareerSafe



PRECISION MACHINING

48.0501 MACHINE TOOL TECHNOLOGY/MACHINIST
(PDE APPROVED PROGRAM OF STUDY)

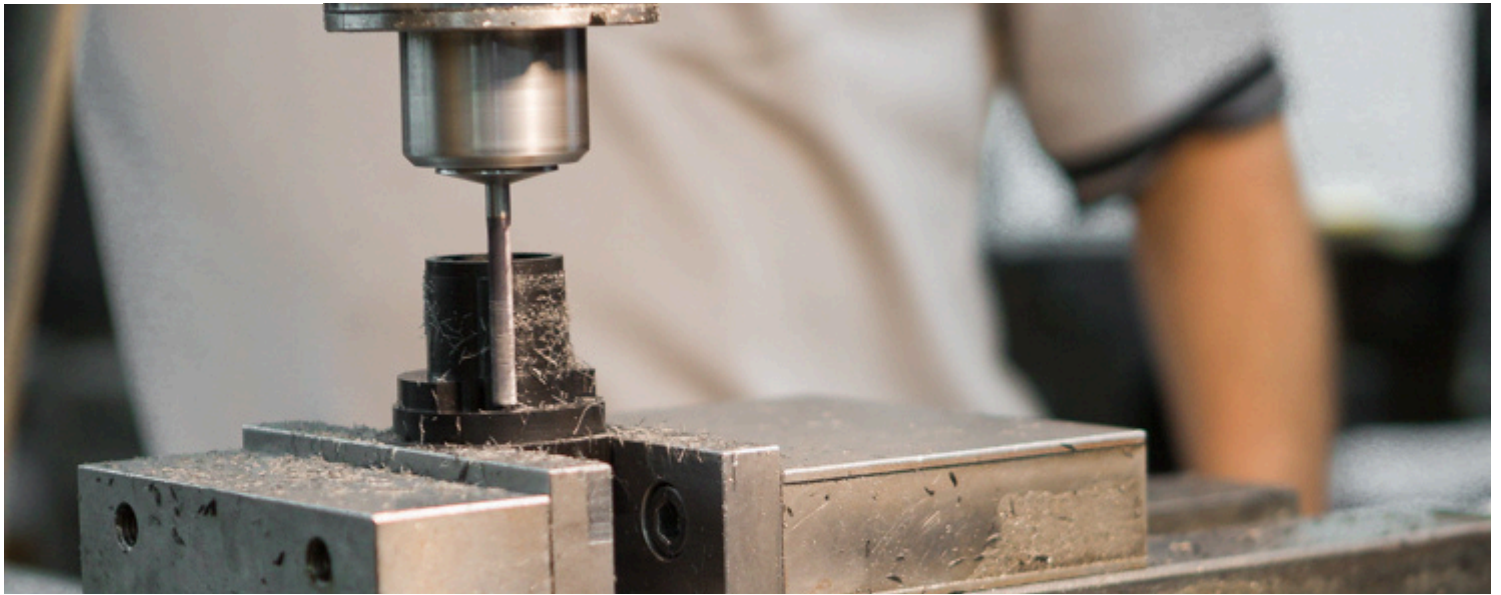

Precision Machining is designed to provide students instruction, knowledge and skills in all aspects of shaping parts for industrial applications. Instruction involves making computations relating to work dimensions, tooling and feeds and speeds of machining. Emphasis is placed upon bench work and the operation of lathes, power saws, milling machines, grinders, drills and computer operated equipment (CNC and CIM). Instruction also includes the use of precision measuring instruments such as layout tools, micrometers and gauges; methods of machining and heat treatment of various metals; blueprint reading; and the layout of machine parts. Instruction prepares students to operate all types of hand and computer controlled machines.

The program provides both practical skills and related theory in machine tool operation, computer-aided design (CAD) along with the technical mathematics, science, and communication skills essential to a career in manufacturing. The program is certified by the National Institute of Metalworking Skills Inc. (NIMS).

Individuals trained in the area of precision machining rank among the top five most needed employees in the United States.



CAREER PATHS

- Machine Tool Setter
- Machinist
- Machine Tool Operator
- Tool and Die Maker
- Mechanical Engineer
- Mechanical Inspector
- CNC Programmer

INDUSTRY CREDENTIALS

Students can earn the following industry-recognized credentials via National Institute for Metalworking Skills, Inc.:

- NIMS Machining Level I
- NIMS Machining Level I CNC milling
- NIMS Machining Level I CNC turning
- NIMS Machining Level I Manual Milling
- NIMS Machining Level I Manual turning between centers
- NIMS Machining Level I Manual turning with chucking
- NIMS Machining Level I Manual Drill Press Operations
- NIMS Machining Level I Measurement, Materials and Safety
- NIMS Machining Level I Planning, Benchwork, Layout



WELDING TECHNOLOGY

48.0508 WELDING TECHNOLOGY/WELDER
(PDE APPROVED PROGRAM OF STUDY)



The Welding Technology Program prepares students to apply technical knowledge and skills in gas, arc, shielded and non-shielded metal arc, brazing, flame cutting and plastic welding. Hand, semi-automatic and automatic welding processes are also included in the instruction. Students learn safety practices and types and uses of electrodes and welding rods; properties of metals; blueprint reading; electrical principles; welding symbols and mechanical drawing; use of equipment for testing welds by ultrasonic methods and destruction and hardness testing; use of manuals and specification charts; use of portable grinders; positioning and clamping. Welding standards are established by the American Welding Society (AWS), American Society of Mechanical Engineers and American Bureau of Ships. The program is certified by the American Welding Society.

CAREER PATHS

- Combination Welders, Cutters, Solderers, & Brazers
- Skilled production Welders and Laborers
- Engineering Technician



Did you know that you can literally work on the bottom of the ocean? Underwater welders are a specialized occupation and can afford opportunities to travel to places that many people would normally not have the opportunity to visit.

INDUSTRY CREDENTIALS

Students can earn the following industry-recognized credentials:

- American Welding Society Welding Certification via American Welding Society



COMPUTER INFORMATION SCIENCE

52.1201 MANAGEMENT INFORMATION SYSTEMS AND BUSINESS DATA PROCESSING
(PDE APPROVED PROGRAM OF STUDY)

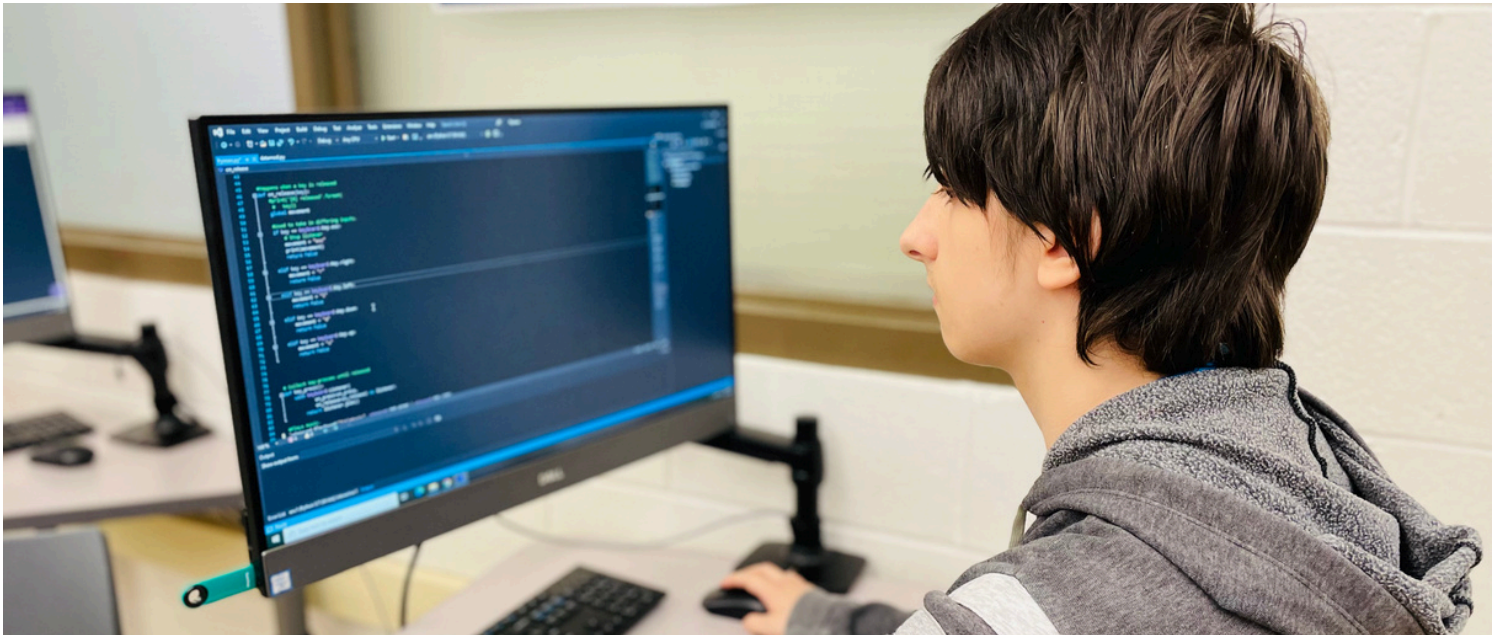

The Computer Information Science Program prepares students to apply technical knowledge and skills to support the design and development of software applications, manage data systems and related mathematical statistics for analysis and forecasting of business data, process and retrieve business information, and prepare and interpret process and data models.

Students will create a relational database, receive instruction in a variety of computer programming languages including writing, testing and debugging code; writing related system user documentation; demonstrating an understanding of core computer concepts to include the internet and the basic functions of business desktop applications; and analyzing common hardware, software and network processes. Students will receive instruction in business ethics and law, economics, office procedures and communications, and will learn office safety, computer fundamentals, database administration and computer maintenance/troubleshooting.

CAREER PATHS

- Computer & Information Systems Managers
- Computer Systems Analysts
- Computer Programmers
- Database Administrators
- Computer Network Architects



Employment in computer and information technology occupations is projected to grow 13 percent over the next ten years, making this one of the fastest growing occupations.

INDUSTRY CREDENTIALS

Students can earn the following industry-recognized credentials:

- Microsoft Certified Professional (MCP) via Microsoft
- Microsoft Office Specialist via Microsoft
- Microsoft Office Specialist via Certiport
- Oracle Certification (path based on product) via Oracle



COMPUTER NETWORKING & SECURITY

11.0901 COMPUTER SYSTEMS NETWORKING AND TELECOMMUNICATIONS
(PDE APPROVED PROGRAM OF STUDY)



The Computer Networking and Security Program focuses on the design, implementation and management of linked systems of computers, peripherals and associated software and prepares individuals with the technical skills required to support networks and network users. This program includes instruction in network technologies and standards: system design, architecture, operating systems, security, communications protocols, client support, messaging services, network management, troubleshooting and server optimization. Those completing the program may be employed as a network administrator, network specialist, network technician, webmaster, client services analyst (end user) or network operator. The core content of this course is focused on nationally recognized certifications. Upon completion of the program, students may be eligible to obtain up to 30 advanced standing credits at a post-secondary institution based on their career track.



Computer and information technology (IT) professionals made a median salary of \$91,250 in May 2020, according to the US Bureau of Labor Statistics (BLS). That's significantly more than the median salary for all other occupations, which was \$41,950.

CAREER PATHS

- Network Systems and Data Communications Analyst
- Information Security Analysts
- Web Developers
- Network and Computer Systems Administrators
- Computer User Support Specialists
- Computer Network Support Specialists

INDUSTRY CREDENTIALS

Students can earn the following industry-recognized credentials:

- A+ via Computing Technology Industry Association (Comp TIA)
- Network+ via Comp TIA
- Security+ via Comp TIA
- Cisco Certified Network Associate (CCNA) via CISCO
- PC Pro via Test Out
- Network Pro via Test Out
- Security Pro via Test Out



GRAPHIC COMMUNICATIONS

10.0399 GRAPHIC COMMUNICATIONS, OTHER
(PDE APPROVED PROGRAM OF STUDY)



Graphic Communications prepares students to apply technical knowledge and skills to plan, prepare and execute commercial and industrial visual image and print products using mechanical, electronic and digital graphic and printing equipment. Students learn desktop publishing, layout, composition, presswork and bindery as well as photography, and several graphic arts techniques. Emphasis is on typographical layout and design using computer graphics, photo typesetting, platemaking, offset preparation and operation, paper cutting, ink and color preparation and dynamics and airbrush and screen printing production.

Concentration in the area of graphic arts will permit the student to work in computer design, digital prepress, press work, Sign making/vehicle graphics, screen printing, sandblasting, and more. In addition, the student will be instructed in various finishing operations.

CAREER PATHS

- Commercial & Industrial Designers
- Graphic Designers
- Desktop Publishers
- Screen Printing / Embroidery
- Prepress / Finishing and Binding
- Printing Press Operators
- Etchers and Engravers



Graphic design allows you to make your own mark while working to meet your clients' needs. With freedom and creativity comes variety, and this makes things fun and sharpens your skills in a variety of visual styles.

INDUSTRY CREDENTIALS

Students can earn the following industry-recognized credentials:

- OSHA Certification via CareerSafe



BUSINESS AND HOSPITALITY MANAGEMENT

52.1801 SALES, DISTRIBUTION AND MARKETING OPERATIONS, GENERAL
(PDE APPROVED PROGRAM OF STUDY)



The Business and Hospitality Management Program focuses on a wide variety of instruction associated with careers in the business and hospitality fields. The program prepares individuals to perform one or more business and hospitality functions such as selling, pricing, promotion (including social media), product/service management, distribution, financing, guest services, front office operations, facilities management, resort management and marketing information management. In addition, this program includes varying emphasis on technical knowledge of products and/or services marketed; related communications, economics, technological and computational skills; and abilities and attitudes associated with human relations. The program may also include management functions associated with owning and operating a business.

CAREER PATHS

- General & Operations Managers
- Advertising & Promotions Managers
- Marketing Managers
- Sales Managers
- First-Line Supervisors of Retail Sales Workers
- Retail Salespersons
- Advertising Sales Agent
- Social Media Specialist
- Sales Representatives
- Guest Relations
- Event Planning
- Entertainment and Leisure Services
- Food and Beverage Operations



According to Mediakix, there is a \$1 billion influencer marketing industry on Instagram, which continues to grow.

INDUSTRY CREDENTIALS

Students can earn the following industry-recognized credentials:

- OSHA Certification via CareerSafe



COSMETOLOGY

12.0401 COSMETOLOGY /COSMETOLOGIST, GENERAL
(PDE APPROVED CAREER TECH PROGRAM)



The Cosmetology Program prepares individuals to apply technical knowledge and skills related to the cosmetology industry in a variety of beauty treatments including the care of the hair, skin, and nails. Instruction includes training in giving shampoos, rinses and scalp treatments; hair styling, setting, cutting, coloring, tinting and lightening; permanent waving; facials; manicuring; and hand and arm massaging. The program includes instruction in bacteriology, anatomy, hygiene, sanitation, salon management including record keeping and customer relations. Instruction is designed to qualify students for the licensing examination upon successfully completing 1,250 hours of instruction.



According to US Bureau of Labor Statistics, more than 30% of all salon industry professionals are self-employed.

CAREER PATHS

- Manicurist
- Hairdresser
- Hairstylist
- Cosmetologist
- Manager
- Skin Care Specialist

INDUSTRY CREDENTIALS

Students can earn the following industry-recognized credentials:

- Cosmetologist via Pennsylvania Department of State, State Board of Cosmetology



CRIMINAL JUSTICE

**43.0107 CRIMINAL JUSTICE/POLICE SCIENCE
(PDE APPROVED PROGRAM OF STUDY)**



The Criminal Justice Program prepares students to apply technical knowledge and skills that relate to performing entry-level duties as a patrolman, corrections officer, juvenile officer, security officer and probation officer. The course stresses patrol and related duties such as traffic and crowd control, the American legal system, techniques used in the police laboratory and training in emergency and disaster situations. Also stressed is physical development with a strong emphasis on self-defense and the building of self-confidence. Investigatory techniques such as interviewing and evidence gathering, report writing, a study of juvenile law and procedure, the techniques of crime prevention, the criminal process from arrest through conviction and procedural matters affecting law enforcement such as arrest, search and seizure and legal principles developed in information lessons are utilized in supervised simulated situations.



Criminal Justice careers are honorable and provide the opportunity for service and a commitment to duty. There are many different aspects associated with careers in the Criminal Justice field, providing a wide range of opportunities.

CAREER PATHS

- Police and Sheriff's Patrol Officer
- Security Officer
- Correctional Officer
- Police, Fire and Ambulance Dispatchers
- Forensic Evidence Technician
- Police and Private Detectives and Investigators
- Bailiffs

INDUSTRY CREDENTIALS

Students can earn the following industry-recognized credentials:

- Certificate of Training - Recognition and Identification of Hazardous Materials (HAZMAT) via Pennsylvania State Fire Academy
- First Aid via American Heart Association
- Adult CPR via American Heart Association
- AED Essentials via American Heart Association
- Certified Protection Officer, CPO via International Foundation for Protection Officers



CULINARY ARTS

12.0508 INSTITUTIONAL FOOD WORKERS
(PDE APPROVED PROGRAM OF STUDY)



The Culinary Arts Program prepares students for employment related to institutional, commercial or other food industry occupations. Instruction and specialized learning experiences include theory, laboratory and work experience related to planning, selecting, preparing and serving of quantity food and food products; nutritive values; use and care of commercial equipment; safety; and sanitation precautions. The MCTI Culinary Arts program is certified by the American Culinary Federation.



MCTI Culinary Arts students run the Laurel Lake Cafe. The cafe is a full service restaurant that is open to the public Tuesday through Friday.

CAREER PATHS

- Chefs and Head Cooks
- First Line Supervisors of Food Preparation and Serving Workers
- Baker
- Cooks, Restaurant
- Cooks, Short Order
- Food Preparation Workers
- Waiter/Waitress

INDUSTRY CREDENTIALS

Students can earn the following industry-recognized credentials:

- OSHA Certification via CareerSafe
- Certified Fundamental Cook (CFC) via American Culinary Federation
- ServSafe/Manager Food Safety Certification via National Restaurant Association
- ServSafe Food Handler Certification via National Restaurant Association
- ProStart National Certificate of Achievement via Pennsylvania Restaurant & Lodging Association (PRLA)
- ServSafe Allergen Certification via ServSafe
- SP2 Workplace Safety Certification via SP2
- SP2 Food Safety Certification via SP2



HEALTH PROFESSIONS

51.9999 HEALTH CARE TECHNOLOGY
(PDE APPROVED PROGRAM OF STUDY)



Health Professions provides students with a variety of educational, informational and biological technology to prepare students for future employment in an ever-changing diverse healthcare field. Students completing this program will find themselves well prepared to enter the workforce as a PCA (Patient Care Attendant) or Homecare Provider. Upon successful completions, students will have obtained First Aid, CPR, AED and Stop The Bleed certifications. The program includes an extensive eight-week shadowing experience for juniors and seniors at an approved medical facility. The student shadowing experience encompasses live interaction within the following disciplines: Emergency Care, Laboratory Procedures, Medical Surgical Unit, Radiology, Respiratory Therapy, Social Services, Therapy, and Ultrasound Technology. Successful students will also be prepared to obtain additional certifications in Phlebotomy, EMT, Medical Assistant, EKG and Nurse Aide with MCTI's Adult Continuing Education evening program and/or participate in an articulation agreement with Northampton Community College.

CAREER PATHS

- Health Technologists and Technicians, All Other
- Healthcare Practitioners and Technical Workers, All Other
- Healthcare Support Workers, Other
- Patient Care Attendant (PCA)
- Homecare Provider



Healthcare is one of the fastest growing sectors of the economy and is estimated to increase 19% between now and 2024, creating over 2 million new job openings.

INDUSTRY CREDENTIALS

Students can earn the following industry-recognized credentials:

- BLS Healthcare Provider via American Heart Association
- Stop The Bleed Certification
- Personal Care Assistant



HORTICULTURE

01.0601 APPLIED HORTICULTURE/HORTICULTURAL OPERATIONS, GENERAL
(PDE APPROVED PROGRAM OF STUDY)



The Horticulture program has a combination of organized subject matter and practical experiences that prepares individuals to produce, process and market plants, shrubs and trees used principally for ornamental, recreational and aesthetic purposes and to establish, maintain and manage horticultural enterprises. Instruction emphasizes knowledge, understanding and application important to establishing, maintaining and managing horticultural enterprises such as arboriculture, floriculture, greenhouse operation and management, landscaping, nursery operation and management and turf management.



Pennsylvania leads the country in mushroom growing. The 68 mushroom farms in the state produced 63 percent of all those in the United States.

CAREER PATHS

- Landscape Architect
- Landscaping and Groundskeeping
- Agricultural Worker
- Nursery and Greenhouse Workers
- Farmers, Ranchers, and Other Agricultural Managers

INDUSTRY CREDENTIALS

Students can earn the following industry-recognized credentials:

- OSHA Certification- Agriculture via CareerSafe
- National Safe Tractor and Machinery Operator via Hazardous Occupations and Safety Training in Agriculture (HOSTA)
- Certified Landscape Technician (CLT) via Pennsylvania Landscape & Nursery Association
- Pennsylvania Certified Horticulturist (PCH) via Pennsylvania Landscape & Nursery Association
- Worker Protection Standard Training via US Environmental Protection Agency Region III



THERAPEUTIC SCIENCE/SPORTS MEDICINE

**51.2604 Rehabilitation Aide
(PDE APPROVED CAREER TECH PROGRAM)**

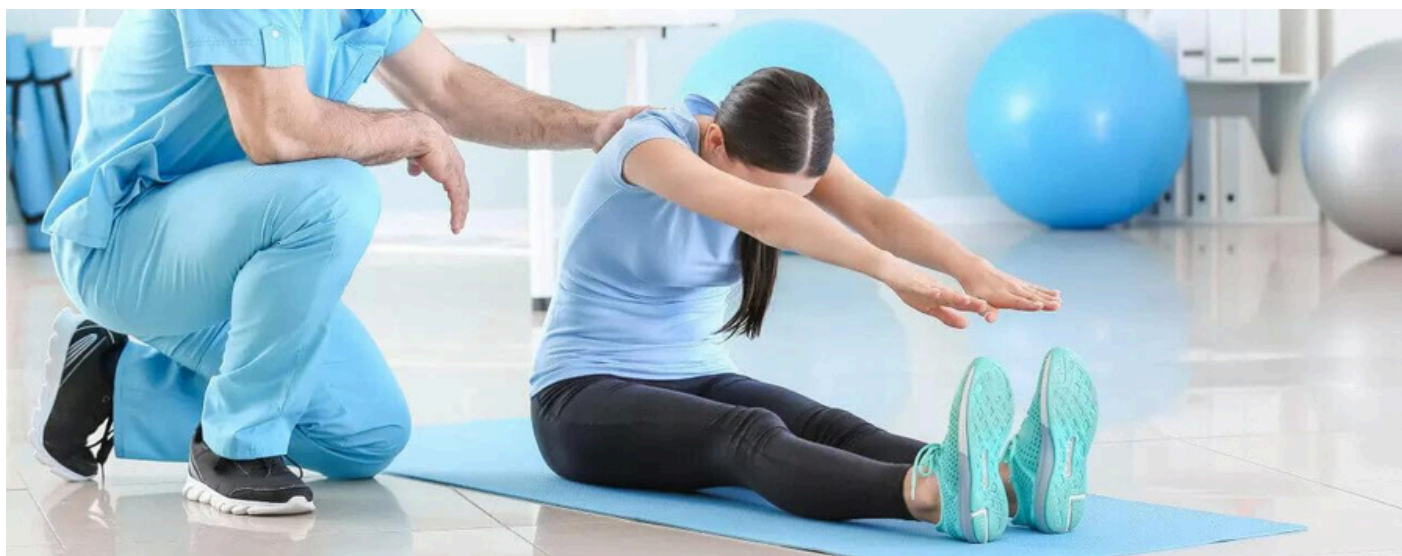

Therapeutic Science and Sports Medicine is a program designed to educate students on the theories of injury prevention, recognition, and emergency care as well as health and wellness. This technical program will include theory and hands on application related to anatomy, physiology, therapeutic exercise, restorative care, strength and conditioning, injury recognition, injury management, weight management and nutrition. Students will learn to design exercise programs, nutrition plans, injury preventative plans, and injury recovery plans that promote overall mental and physical health and wellness. Students will leave the program prepared for employment in settings that include fitness clubs, assisted care facilities, and wellness programs. Students who wish to pursue an advanced degree will have a strong foundation to enter post-secondary programs in the fields of exercise science, physical therapy, occupational therapy, and athletic training.

CAREER PATHS

- Personal Trainer
- Strength & Conditioning Coach
- Sports Performance Coach
- Physical Therapist Assistant
- Massage Therapist
- Rehabilitation Aide
- Sports Medicine
- Athletic Trainer
- Occupational Therapist
- Physical Therapist



Employment in the field has a bright outlook and is predicted to grow 14 percent between 2022-2032 which is faster than average.

INDUSTRY CREDENTIALS

Students can earn the following industry-recognized credentials:

- OSHA Certification- Healthcare via CareerSafe
- First Aid CPR AED via American Heart Association
- Physical Therapy Technicain/Aide Certification - AMCA
- Certified Personal Trainer - NASM



DIVERSIFIED OCCUPATIONS

32.0105 JOB-SEEKING/CHANGING SKILLS
(PDE APPROVED TECH PREP PROGRAM)



The Diversified Occupations Program (D.O.) is a one-year instructional program for seniors that operates as an integral part of vocational education to provide a cooperative arrangement between the school and employers whereby the student receives general education instruction in the school and on-the-job training through part-time employment in business/industry. The area of training may be in any vocational education area where there are needs for trained persons and must relate to the student's career objective.

The D.O. Program is a partnership between MCTI, the sending district, the student and the student's parents/guardians, and the employer. This training program is designed to help the student to transition from school to the world of work while gaining valuable life and work experience. Students are responsible for finding part-time employment with a local employer which is directly related to the career field they wish to pursue after graduating from high school. This program is conducted at the student's district high school campus.

CAREER PATHS

Career opportunities will be determined upon receiving employment in a specific industry.

INDUSTRY CREDENTIALS

Students can earn the following industry-recognized credentials:

OSHA Certification via CareerSafe

Get Involved!



CAREER AND TECHNICAL STUDENT ORGANIZATIONS (CTSO)

Every program provides opportunities for participation in a CTSO. CTSOs are vocational student organizations primarily based in high schools, colleges and career technology centers, similar to school clubs and extracurricular activities. More information about specific organizations is available through the program instructor.



National Technical
Honor Society



Interact
Rotary Sponsored Club





**MCTI STUDENTS CAN
EARN COLLEGE
CREDITS THROUGH
ARTICULATION
AGREEMENTS!**

SOAR- Statewide Articulation Agreements

<https://www.collegetransfer.net/Search/PA-Bureau-of-CTE-SOAR-Programs>

The mission of SOAR (Students Occupationally and Academically Ready) is to prepare students for college and careers in a diverse, high-performing workforce by allowing students to transfer credits to the post-secondary level. To be eligible for articulated credits under the SOAR program students must complete their POS task list at the proficient level, score competent or advanced on their NOCTI, and earn a 2.75 program GPA.

Local Articulation Agreements

https://docs.google.com/spreadsheets/d/1eov4nStARjOKbQQ_HBo2BSUfgePKV-IA-dCERV9X2YE/edit?gid=0#gid=0

Articulation agreements are formal partnerships between educational institutions that outline the terms and conditions for the transfer of credits. These agreements specify which courses taken at one institution will be recognized and accepted for credit by another institution. They are designed to provide a clear pathway for students to transfer from one educational program to another while ensuring the continuity of their academic progress.

For more information please contact Abigail Tomsho.

atomsho@monroecti.org

570-629-2001 ext 1117



HOW DO I APPLY?

-Contact-

Contact MCTI or your School Counselor. More information can be found at www.monroecti.org.

-Apply-

Complete an online application on our website.

Apply Now!

*Your Future
Starts Here!*

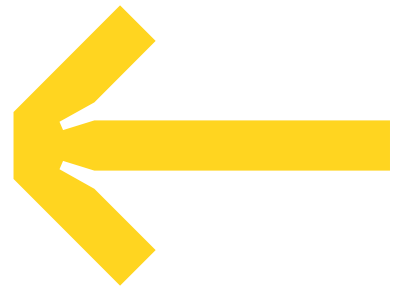

FOLLOW US!



MONROE CAREER & TECHNICAL INSTITUTE

194 LAUREL LAKE RD, BARTONSVILLE, PA 18321

WWW.MONROECTI.ORG

(570) 629-2001

The Monroe Career & Technical Institute is an equal education institution and will not discriminate on the basis of age, race, color, national origin, gender or handicap in its activities, programs or employment practices as required by Title VI, Title IX, Section 504 and the Americans with Disabilities Act. For information regarding civil rights or grievance procedures, and information regarding services, activities and facilities that are accessible to and usable by handicapped persons, contact the Frank Zaso, Supervisor of Curriculum & Instruction, at 194 Laurel Lake Rd, Bartonsville, PA 18321 (570) 629-2001.