

MEMORANDUM FOR ALL CADETS

12 August 2024

From: TX-20063rd AFJROTC Senior Aerospace Science Instructor

Subject: Cadet Guide Welcome Letter

1. Welcome to Air Force Junior Reserve Officer Training Corps (AFJROTC) at Tivy High School. Our mission is **“To develop citizens of character.”** Everything we do seeks to accomplish this mission.

2. AFJROTC is the best citizenship and leadership development program available to high school students in our nation. Our program is built on the Air Force Core Values of **Integrity First, Service Before Self, and Excellence in All We Do.** You are here to learn how to apply these core values so they become much more than simple head knowledge. Our hope and goal is that you choose to embody these principles so you try to live your life by them each day. We want these principles to become a big part of who you are as a person.

3. By being a part of AFJROTC, you will develop your leadership skills and understand the importance of service to each other, to our community, and our nation. You will be a member of a true team and part of a superb, award winning, Corps of cadets. Your involvement in class, properly wearing the uniform once per week, keeping yourself well groomed, and participating in our Leadership Development Requirements (LDRs) are all critical and are non-negotiable. Proper behavior in and outside of AFJROTC is also important. This Cadet Guide provides the foundation of information that you will need to understand to succeed in the program and in life. Most of your cadet questions will be answered in this guide.

4. Membership in AFJROTC at Tivy High School is a privilege, not a right. Failure to maintain proper behavior, grooming standards, and uniform wear requirements will result in removal from the program.

5. Your interest, participation, and enthusiasm is critical to having an outstanding program and is expected. The more involved you are in your Corps, the better. There are so many activities and teams called “Leadership Development Requirements” for you to be a part of that will give you the opportunities to learn and develop your leadership, service and teambuilding skills. Welcome to Tivy High School AFJROTC and the TX-20063<sup>rd</sup> Corps of Cadets. You will have fun in AFJROTC!

&lt;&lt;e-signed/jba/12 Aug 24&gt;&gt;

JOHN B. APOSTOLIDES, Lt Col, USAF (Ret)

Tivy High School, SASI – TX-20063

**THIS CADET GUIDE BELONGS TO:**

---

**FLIGHT**

**TX-20063<sup>rd</sup> CADET GUIDE**

This is the operations guide TX-20063<sup>rd</sup> cadets will use during 2024-25 school year. Each cadet should use the information in this guide as a reference source while enrolled in the JROTC program. It has all the information a cadet needs to answer most questions regarding expectations, academic, classroom procedures, and uniform wear. The handbook is composed of 17 chapters with 19 attachments, each addressing a different aspect of knowledge cadets are expected to gain. Take advantage of the information to assist you in your Air Force JROTC experience.

## TABLE OF CONTENTS

<b>CHAPTER</b>	<b>TITLE</b>	<b>PAGE</b>
1.	The Pledge, National Anthem, Air Force Song, Cadet Creed, & - Scope of the TX-20063 AFJROTC Program	5-7
2.	Values & The Honor Code	10
3.	Military Customs and Courtesies	12
4.	Classroom Conduct and Procedures	14
5.	Personal Appearance of Cadets	19
6.	The United States Air Force Uniform	26
7.	Grading System and Assignment Make-up Policy	33
8.	LDRs, Teams, and Corps Meetings & Letterman Jacket Criteria	37
9.	Organizational Charts of the TX-20063 <sup>rd</sup> Corps of Cadets	42
10.	Cadet Promotions	46
11.	Job Descriptions	48
12.	Unit Manning Document/Rank Listing	60
13.	National and Local AFJROTC Awards and Decorations	62
14.	Certificates of Completion and Training	73
15.	7-Year Curriculum Plan & Course Offerings	75
16.	Admission, Transfer, and Disenrollment of Cadets D. Discipline	76

## LIST OF ATTACHMENTS

<b>ATTACHMENTS</b>	<b>TITLE</b>	<b>PAGE</b>
1.	Uniform Issue Receipt	85
2.	Tivy High School AFJROTC Letterman Jacket Requirements	86
3.	Air Force Junior ROTC Badges	87
4.	Cadet Ranks	89
5.	Cadet Male Headgear / Cadet Female Headgear	90
6.	Cadet Beret Headgear	92
7.	Cadet ABU's and ABU Headgear	93
8.	Cadet Lightweight Blue Jacket	95
9.	Cadet Male Service Dress / Cadet Female Service Dress	96
10.	Cadet Male Blue Shirt / Cadet Female Blue Shirt	98
11.	Cadet Flight Suit	100
12.	Cadet Semi-Formal Dress Uniform (male)	101
13.	Cadet Sample Exhibition Drill Uniform	102
14.	Sample Cadet Uniform Pictures	104
15.	Drill Manual Extract	107
16.	Acronyms	112
17.	Insignia of the United States Armed Forces	113
18.	TX-20063 Leadership Cord Tracker	115
19.	Update to Dress and Appearance (Aug 2021)	116
20.	AFJROTC Ribbon Chart	120

## CHAPTER 1

### The Pledge of Allegiance

I pledge allegiance to the flag of the United States of America,

And to the republic for which it stands, one nation, under God,  
indivisible, with liberty and justice for all.

### **The Star-Spangled Banner**

Oh, say can you see, by the dawn's early light,  
What so proudly we hailed at the twilight's  
last gleaming?

Whose broad stripes and bright stars, through the  
perilous fight, O'er the ramparts we watched, were so  
gallantly streaming?

And the rockets' red glare, the bombs bursting  
in air, Gave proof through the night that our  
flag was still there.

O say, does that Star - Spangled Banner yet wave  
O'er the land of the free and the home of the brave?

On the shore, dimly seen through the mists of the deep,  
Where the foe's haughty host in dread silence reposes,  
What is that which the breeze, o'er the  
towering steep, As it fitfully blows, now  
conceals, now discloses? Now it catches the  
gleam of the morning's first beam, In full  
glory reflected now shines on the stream:

'Tis the star-spangled banner! O long may it wave  
O'er the land of the free and the home of the brave.

And where is that band who so  
vauntingly swore That the havoc of  
war and the battle's confusion A home  
and a country should leave us no  
more?

Their blood has wiped out their foul footstep's pollution.

No refuge could save the hireling and  
slave From the terror of flight, or the  
gloom of the grave: And the star-  
spangled banner in triumph doth wave  
O'er the land of the free and the home of  
the brave.

Oh! thus be it ever, when freemen shall stand  
Between their loved homes and the war's desolation!  
Blest with victory and peace, may the heaven-rescued  
land Praise the Power that hath made and preserved us  
a nation.

Then conquer we must, when our cause it is just,  
And this be our motto: "In God is our trust."

And the Star - Spangled Banner in triumph  
shall wave O'er the land of the free and the  
home of the brave!

### **The Air Force Song**

Off we go into the wild blue yonder,  
Climbing high into the sun;  
Here they come zooming to meet our thunder,  
At 'em boys, Give 'er the gun! (Give 'er the  
gun now!) Down we dive, spouting our  
flame from under, Off with one helluva  
roar!  
We live in fame or go down in flame.  
Hey! Nothing'll stop the U.S. Air Force!

Additional verses:  
Minds of men fashioned a crate of thunder,  
Sent it high into the blue;  
Hands of men blasted the world asunder;  
How they lived God only knew! (God only  
knew then!) Souls of men dreaming of skies  
to conquer Gave us wings, ever to soar!  
With scouts before And bombers galore.  
Hey! Nothing'll stop the U.S. Air Force!

Bridge: "A Toast to the Host"  
Here's a toast to the host  
Of those who love the vastness of the sky, To a  
friend we send a message of his brother men  
who fly.  
We drink to those who gave their all of  
old, Then down we roar to score the  
rainbow's pot of gold.  
A toast to the host of men we boast, the U.S. Air Force!  
Zoom!

Off we go into the wild sky yonder,  
Keep the wings level and true;  
If you'd live to be a grey-haired wonder  
Keep the nose out of the blue! (Out of the  
blue, boy!) Flying men, guarding the  
nation's border, We'll be there, followed  
by more!  
In echelon we carry on. Hey!

Nothing'll stop the U.S. Air Force!

Words & music by Robert Crawford

## **AFJROTC Cadet Creed**

**I am an Air Force Junior ROTC Cadet.**

**I am connected and faithful to every Corps of Cadets who serve their community and nation with patriotism.**

**I earn respect when I uphold the Core Values of Integrity First, Service Before Self, and Excellence In All We Do.**

**I will always conduct myself to bring credit to my family, school, Corps of Cadets, community, and to myself.**

**My character defines me.**

**I will not lie, cheat, or steal. I am accountable for my actions and deeds.**

**I will hold others accountable for their actions as well.**

**I will honor those I serve with, those who have gone before me, and those who will come after me.**

**I am a Patriot, a Leader, and a Wingman devoted to those I follow, serve, and lead.**

**I am an Air Force Junior ROTC Cadet.**

### ***SCOPE OF THE TX-20063 AFJROTC PROGRAM***

Program Scope: The Tivy High School (THS) Air Force Junior Reserve Officer Training Course (AFJROTC) is designated as “TX-20063.” The primary purpose of TX-20063 is to help develop better citizens through a leadership development program. Students **NEVER** incur a military service obligation by participating in the program. Each course taught emphasizes education and practical skill development in three basic areas: Aerospace Science, Leadership Education, and Wellness.

1. The **mission** of the Air Force Junior ROTC (AFJROTC) program is to:

**“Develop Citizens of Character”**

2. The **goals** of the AFJROTC program are to instill:
  - The values of citizenship,
  - Service to the United States,
  - Personal responsibility, and • A sense of accomplishment.
  
3. The **objectives** of AFJROTC are to educate and train high school cadets in citizenship; promote community service; instill responsibility, character, and self-discipline; and provide instruction in air and space fundamentals.
  
4. This program will enable the students to:
  - Develop a high degree of strong morals, self-esteem, self-reliance, personal appearance and leadership.
  - Adhere to the values of integrity, service, and excellence.
  - Increase their understanding of patriotism and responsibilities as US citizens.
  - Participate in community service activities.
  - Expand their skills of critical thinking and problem solving, communication and collaboration, and creativity and innovation.
  - Demonstrate military customs, courtesies, and traditions and develop habits of order, discipline, and social skills.
  - Acquire a broad-based knowledge of aerospace studies and leadership education.
    - Strive to graduate from high school and prepare for college and careers in the 21<sup>st</sup> century.
  - Cultivate a commitment to physical fitness and a healthy lifestyle.



5. AFJROTC cadets affirm to:
  - a. Create and maintain standards of the highest order.
  - b. Respect school property to the fullest extent.
  - c. Respect all teachers, instructors, appointed AFJROTC officers, and classmates.
  - d. Obey instructions from our teachers, appointed AFJROTC officers and non-commissioned officers.
  - e. Recognize and appreciate the sacrifices parents / guardians have made to further their education and to show them all due respect and gratitude.
  - f. Take pride in wearing my AFJROTC uniform. Wear the uniform properly and with respect and ACT PROFESSIONALLY.
  - g. Love and revere our community, country, flag, and our US Constitution which guarantees our freedoms and rights.

## CHAPTER 2

### *VALUES & THE HONOR CODE*

**CORE VALUES:** When we look at the mission of Air Force Junior ROTC we see the words “**Develop Citizens of Character.**” As AFJROTC cadets you are expected to meet a higher standard of ethics and to do that, you first must understand some terms that apply to values that should already be important to you. These are the Air Force Core Values.

1. **Integrity First** is the essential element upon which other values are built. Integrity is being honest with others as well as with yourself. Integrity is doing what is right at all times, even when no one else is looking.
2. **Service Before Self** calls for having a sense of commitment and dedication for the needs of others, the community, and the environment. It is thinking of others before yourself.
3. **Excellence in All We Do** is the desire to do the very best you can in everything you do.

These values serve as our road map and set the standard of our behavior. They serve to remind us of the importance of setting and meeting higher standards of performance as we pursue our goals in life.

**THE CADET HONOR CODE:** We can take a lesson from all the military service academies whose young men and women adhere to a strict honor code.

**“I will not lie, cheat, or steal, nor tolerate those that do.”**

- **Lie** - a statement of untruth, meant to deceive or mislead OR telling a “partial truth” with the intent to deceive or mislead.
- **Cheat** - take unfair advantage or gaining an unearned advantage.
- **Steal** - deprive some one of their property without their permission or without payment.

If you become aware of lying, cheating, or stealing, report the incident to the cadet chain of command and the instructors.

## CHAPTER 3

### MILITARY CUSTOMS AND COURTESIES

1. Cadets are held to a higher standard of courtesy and conduct. You are expected to observe correct military conduct at all times in and out of school. **Positive behavior reflects credit upon yourself, your family, your school, and the TX-20063<sup>rd</sup> Corps of Cadets.**
2. The salute is a friendly military exchange of greeting throughout the world. Military personnel consider the salute a courteous and respectful greeting among members and it is one of the oldest traditions binding military professionals together.
3. When outdoors and in uniform, saluting is required. At Tivy High School while outside, you will salute and extend a verbal greeting to the instructors and cadet officers. If you meet an active duty officer visiting the campus, you will also render a salute. Salute when you recognize the person and eye contact is made with him/her within a reasonable distance.
4. The salute is rendered indoors only when cadets are reporting to cadet officers or the instructors or during presentations. When attempting to enter the Junior ROTC Instructor Reception Office (JIRO) or the SASI, or ASI office, cadets should KNOCK ONCE and wait for permission to enter/come in.
  - a. To enter the classroom. March directly to the cadet officer in charge, salute and state your business.
  - b. To enter the SASI office. The cadet will march directly to the front of the desk. Stop and stand two paces in front of the desk. Salute sharply. Report “Sir/Ma’am, Cadet (Rank and Last name) reports or reports as ordered.” Hold the salute until the SASI returns your salute. Respond appropriately. When the purpose of the report or meeting is completed, the cadet again salutes, and waits until the salute is returned or otherwise acknowledged, and the cadet will perform an appropriate facing movement and leave by the most direct route. Note:
  - c. The ONLY “No Salute Area” is the bus stop patio outside of the cafeteria.
5. Salutes are never given or returned while running. The cadet will instead come to quick time (a walk) and render the salute.
6. Cadets not in uniform *may* salute as if they are in uniform.
7. If a cadet observes the American flag being raised or lowered from any flag staff, he or she will assume the position of attention, render the hand salute (if in uniform) and hold it until the flag has reached the top summit or bottom base of the flag staff. If the cadet is in civilian clothes, he or she will assume the position of

attention, and place the right hand over the heart. If a cadet is wearing civilian attire including headgear, he or she will remove the headgear and hold it to his or her left shoulder so the right hand is over the heart.

8. If the Pledge of Allegiance is recited and a cadet is in uniform indoors, the cadet should stand at attention, face the flag, and remain silent. If most of those present are in civilian clothes, however, the cadet should stand at attention and may exercise the option of joining with the others in reciting the pledge.
9. If the Pledge of Allegiance is recited and a cadet is in uniform outdoors, the cadet should stand at attention, remain silent, face the flag, and render the hand salute
10. If the Pledge of Allegiance is recited and a cadet is not in uniform indoors or outdoors, the cadet should stand at attention, face the flag, and recite the pledge. The right hand is placed over the heart during the recitation, and cadets will hold hats, if worn, as described in 7, above.
11. If the National Anthem is being played, and a cadet is in uniform outdoors, the cadet should stand at attention, face the flag (if it is visible, or face in the direction of the music if not,) and salute. (If no flag is visible, the cadet should simply face straight ahead while saluting.)
12. If the National Anthem is being played, and a cadet is not in uniform outdoors, the cadet should stand at attention, face the flag, and place the right hand over the heart (cadets will also hold the hat in the right hand as described in 7 above). If in civilian clothes, indoors, the cadet will stand at attention and face the flag, if visible or in the direction of the music if it is not.
13. If a cadet is late for a formation, he or she will approach the cadet or person in charge when the formation is at a halt, salute, and request permission to fall in.
14. Cadet Officers and cadet NCOs should correct saluting errors in a courteous and helpful manner when cadets junior to them commit such errors. All cadets are expected to accept such corrections properly.

## **CHAPTER 4**

### ***CLASSROOM CONDUCT AND PROCEDURES***

Cadets are expected to observe correct military conduct at all times. Such behavior will reflect credit upon themselves, their parents, the TX-20063<sup>rd</sup>, Tivy High School and the United States Air Force. Officer and enlisted cadets will be graded on leadership/followership, as appropriate, at the end of each week.

**CLASSROOM PROCEDURES:** Place all cell phones in the boxes at the front of the classroom before class begins. At the beginning of the class, the Flight Commander will call state “standby” and then call the flight to attention and lead the class in the Pledge of Allegiance. After the pledge the Flight Sergeant will command “Report.” Each element leader, beginning with the first, will report to the Flight Sergeant the

name of any cadet who is absent by saluting and stating, “Sir/Ma’am, 1<sup>st</sup>, 2<sup>nd</sup>, 3<sup>rd</sup>, or 4<sup>th</sup> element reports all cadets are present and accounted for with the exception of Cadet(s) (last name).” If no cadets are absent, the element leader will state “Sir/Ma’am 1<sup>st</sup>, 2<sup>nd</sup>, 3<sup>rd</sup>, 4<sup>th</sup>, element reports all cadets are present and accounted for.” The Flight Sergeant will report to the Flight Commander who will in turn report to the instructor. If the Flight Commander is absent, the Flight Sergeant will replace him or her, and element leaders and assistants will fill in as needed. If the Flight Sergeant is absent, the first element leader will move up. If any element leader is absent, the assistant element leader will take his or her place.

- Promptness is an objective of the program and cadets are expected to be behind their chairs before the tardy bell rings. Classroom instruction begins with all cadets are standing at attention behind their chairs. After the Flight Commander (FC) has reported attendance to the instructor, he will then review the Communication Board and answer any questions from the flight. The FC will then turn the room over to an Instructor for the academic lesson.
- In the event the instructor is delayed, the Flight Commander may, at his or her option, seat the flight. Once seated, the Flight Commander will give the command “In Seats, ATTENTION” when the instructor enters. Cadets will then assume a position of attention while seated and maintain it until the report is given and the instructor orders “At Ease.” Note that the instructions in this paragraph apply only at the beginning of a class, not at dismissal time.
- Cadets who enter the classroom after the tardy bell has sounded will delay reporting in until the instructor has received the flight attendance report. The tardy cadet will then report in to the Flight Commander stating “Sir/Ma’am, Cadet (last name) requests permission to join the flight.” Any excuse slip will be presented at that time. **Cadets without a tardy slip will explain their tardiness.** If the instructor is not present when the tardy cadet arrives, the cadet will report in to the Flight Commander who will in turn inform the instructor.

### **MOVING TO & FROM OUTDOOR FIELD ACTIVITIES DURING A CLASS PERIOD:**

The flight commander and/or Flight Sergeant will march cadets to outdoor field activities in a “Column of Twos” formation. Inside the school building, cadets will exit the room in single file and form up into two columns in the hallway outside of the classroom.

**CLASSROOM DISMISSAL:** With two minutes remaining in the class period, the instructor will turn the class over to the Flight Commander who will remind cadets of upcoming activities and events. All tables need to be cleared and straight. When the bell rings, cadets will wait for the Flight Commander to command “Flight, TENCH HUT,” cadets will stand, place their chairs neatly behind their tables and come to the “Position of Attention.” The Flight Commander will then command “DISMISSED.” Cadets will collect all their items and depart from the classroom in an orderly manner. Element leaders are responsible to ensure all tables are straight and chairs placed

neatly behind the desks. The Flight Commander and Flight Sergeant will depart last making a final check of the classroom prior to leaving.

**GENERAL INFORMATION:** There are general rules that all cadets are expected to follow while in the AFJROTC classroom.

**Asking a Question or Responding to a Question:** To ask a question, cadets will raise their hand. Once recognized, they will ask their question. In a formal lecture class with a guest speaker or VIP when a cadet is asked a question, they will stand and respond. They should remain standing until the conversation regarding the question is completed, or are instructed to be seated.

**Cadet in Charge:** Cadets have earned positions of responsibility within the Cadet Corps. Those designated as the “cadet in charge” are responsible for meeting commitments assigned. Cadets assigned to groups under the purview of a cadet in charge must comply with all legal instructions and requests as they pertain to the assignment of a task.

**Calling the Room to Attention:** Under normal circumstances, the room is called to attention when the SASI, Superintendent, Principal/Assistant Principal, or a Distinguished Visitor enters the classroom, however, once formal classroom instruction has begun (e.g. the academic lesson for the day) do not interrupt the flow of the class by calling the room to attention. Also, do not call the room to attention if there is an officer of equal or higher rank already in the room. The Flight Commander and Flight Sergeant needs to be attentive and use good judgment in this area. When the room is called to attention, cadets will remain at attention until given the command “As you were” or “Carry on.”

### **Class Preparation**

- Bring proper materials to class. You are required to bring AFJROTC notebook/binder, pens, pencils, and paper to class each day. Writing utensils will not be provided by the instructors. Open your binder to your planner and be prepared to annotate dates.
- DO NOT bring materials that do not pertain to JROTC (magazines, cards, etc.)

### **Courtesy**

- Be attentive when someone else is speaking.
- Do not interrupt, wait for your opportunity to speak.
- **SLEEPING IN CLASS WILL NOT BE TOLERATED.** If you are having problems staying awake, **quietly stand up** and move to the rear of the classroom and stand.
- **Do not** leave your assigned seat during class unless you have permission from the Flight Commander or the instructor.

### **Expectations**

- **Sit in chairs, NOT on tables.** Do not roll around the room in the chairs.

- No feet on chairs, desks or tables for any reason.
- **Do not** wear hats, caps, or hoodies in the classroom. Hats are not allowed indoors at school.
- **No** gum in the classroom.
- Water and Gatorade are authorized. However, no previously opened containers can be brought into the classroom.
- Edibles and candy are only allowed with instructor permission.
- Leave all personal problems outside the classroom; “drama” is best left off campus.

### **Hall Pass/Leaving Class**

- During the class period, no one will leave the classroom without the instructor’s permission. A hall pass will be required at all times while outside the classroom unless in flight formation.

### **Illness/Nurse Visit**

- Let the instructor know if you are ill. Cadets visiting the nurse must have a “nurse pass” from the instructor prior to leaving the classroom. Cadets will be escorted by the Flight Sergeant or other designated cadet (who will take the hall pass), to the nurse’s office.

### **Learn to Think Before Speaking**

- Try to do things yourself rather than asking questions that are not necessary. Try to rely on your own abilities first, instead of automatically asking for the answer. In most instances, your questions will be answered if you listen to the information given by the Corps staff or instructors.

### **Notebooks**

- Academic Planners will be issued to each cadet. Cadets are expected to keep their planners up to date for all classes. Keep planners current and accurate. They can be graded by instructors.

### **Storage of Cellular Phones During Class**

AFJROTC is **NOT** a Bring Your Own Device (BYOD) classroom. Prior to the start of each class cadets will store their cellular phones in a cabinet drawer at the front of the classroom. Cadets will use the drawer corresponding to their element (row) in the class: 1<sup>st</sup> element top drawer, 2<sup>nd</sup> element second drawer, and so on. Phones should be on silent mode. During the final two minutes of class, when directed, cadets will retrieve their phones.

### **Uniform Wear**

- Wear the proper blue uniform on inspection day (on each Wednesday or as directed) and fitness appropriate wear on physical training days.

- Friday is usually wellness day and cadets must wear athletic clothing and athletic shoes for their JROTC class. Failure to wear the appropriate athletic shoes or clothing will result in a 69 maximum grade for wellness.
- TX-20063 has a “**3 strikes and you are out**” policy regarding failure to wear the AFJROTC uniform. Failure to wear the JROTC uniform three (3) times in any semester will likely result removal from the program. The SASI is the final decision authority for all removal actions. Parental contact should be attempted/accomplished prior to removal. NOTE: Removal for substandard performance or refusal to wear the JROTC uniform or failure to maintain grooming standards could occur at any time during the school year and consequently the student could lose credit for the semester.

### **Use of Audio/Visual Recording Devices**

- Taking photos or making audio or video recordings without permission in ANY context in which the person has a reasonable expectation of privacy is prohibited. Such physical areas on campus include but are not limited to private offices, classrooms, storage rooms, supply rooms and the armory. In such areas, permission must be granted by all persons being photographed or recorded.
- The use of any audio/video recording devices during classroom instructional periods must be approved by the class instructor.
- Violations will result in disciplinary action, up to and including removal from the AFJROTC program. This action will be in addition to any disciplinary action for violating the KISD electronics use policy.

### **Work Assignments, Homework & Projects**

- Turn in all homework and project assignments on time based on the Kerrville ISD grading/late policy.

**PUBLIC DISPLAY OF AFFECTION (PDA):** While wearing the AFJROTC uniform, both on and off campus, close physical contact such as holding hands, cuddling, embracing, kissing, and any other public display of affection is **strictly prohibited**. When not in uniform, KISD Student Handbook restrictions apply. PDA discredits AFJROTC, since indiscriminate displays of affection show a lack of maturity, discipline and restraint in public. It detracts from the professional image of the Air Force. It can also be harmful to the good order, discipline, and morale of the Cadet Corps. Individuals displaying a lack of maturity risk a lower AFJROTC leadership grade for their conduct.

### **JROTC INSTRUCTOR RECEPTION OFFICE (JIRO) Policy:**

Cadets are not allowed in the JIRO, with the exception of the Top Staff and any cadets the Corps Commander, SASI or ASI allow. This policy is in place during school hours to maintain an organized and clean work area and limit distractions from work that



needs to be accomplished. There is no eating or drinking in the JIRO. The JIRO is a work area and must be kept clean and functional.

## CHAPTER 5

### ***PERSONAL APPEARANCE OF CADETS***

1. You are issued and required to wear the official uniform of the United States Air Force. Your proper conduct, actions, and attitudes will create and sustain a favorable public impression which will enhance your image and that of the TX-20063<sup>rd</sup>. Any objectionable behavior in public will create an unfavorable impression towards the AFJROTC program and the Air Force. As an Air Force Junior ROTC cadet, you must constantly strive to present a neat, clean, and well-groomed appearance.

#### Specific Male Cadet Grooming Guidelines.

(Refer to Figure 1)

- **Hair.** Keep your hair clean, neat, and trimmed. It must not contain large amounts of grooming aids such as greasy creams, oils, and sprays that remain visible in the hair. When your hair is groomed, it should not touch your ears or eyebrows, and only the closely cut or shaved hair on the back of your neck should touch the collar.
- Male hair should not exceed 2 inches in bulk regardless of the length on the top of the head and will not exceed 1/4 inch at the termination point on the back of the head. Bulk is the distance that the hair projects from the scalp when groomed (as opposed to length of the hair). The bulk and length of your hair must not interfere with wearing any Air Force headgear properly, and it must not protrude below the front band of the headgear. Your hair must have a tapered appearance on both sides and back, both with and without headgear. A tapered appearance means that, when viewed from any angle, the outline of the hair on the side and back will generally match the shape of the skull, curving inward to the end point. Military “High and Tight” cuts are authorized.
- Male cadets whose hair is not in accordance with the above rules will have points deducted from their weekly uniform grade. Minus 31 points for the first violation, minus 62 points for the second consecutive violation, a zero uniform grade for the third consecutive violation, and continued violations may constitute grounds for probation and subsequent removal from AFJROTC. Faddish haircuts will result in a “0” as a grade for that uniform wear week and are grounds for dismissal from the program.
- Braided hairstyles, spikes, lines or Initials/lettering shaved into the head are not authorized, nor are bizarre hair styles, including unnatural hair colors, and partially shaved heads. Your hair may not contain or have attached to it any visible foreign items. If you dye your hair, it should look natural. You may not dye your hair an unusual color or one that contrasts with your natural coloring. Sideburns must be neatly trimmed and tapered in the same manner as your haircut and must be straight and of even width (not flared) and end in a clean-shaven horizontal line. They may not extend below the lowest part of the outer ear opening. No extreme or

faddish hair styles are allowed. Hair may not protrude below the front band of properly worn headgear.

- Mustaches are generally discouraged but are allowed if they follow the guidance below. Mustaches will be conservative (moderate, being within reasonable limits; not excessive or extreme) and will not extend downward beyond the lip line of the upper lip or extend sideways beyond a vertical line drawn upward from both corners of the mouth. See Figure 1-1, reference points B, C, and D.
- Any other facial hair is not authorized unless for medical / religious reasons. Cadet must submit medical / religious facial hair waiver request to SASI for authorization. SASI will submit waiver request in WINGS for review by HQ AFJROTC Waiver Review board.
- Sideburns will be neatly trimmed. Sideburns will not extend beyond the lowest part of the exterior ear opening, will be straight and even width (not flared), and will end with a clean-shaven horizontal line.
- Male cadets will NOT wear earrings/gauges or tongue/facial piercing jewelry anytime during the school day or during any AFJROTC functions. Any cadet in violation of this rule may be considered for removal from AFJROTC.
- Males are not permitted to paint or grow their fingernails.
- Piercings or gauges are not authorized.
- ADDITIONAL GUIDANCE ON MALE HAIR - ATTACHMENT 19

Figure 1. **Male Hair Grooming Standards.**

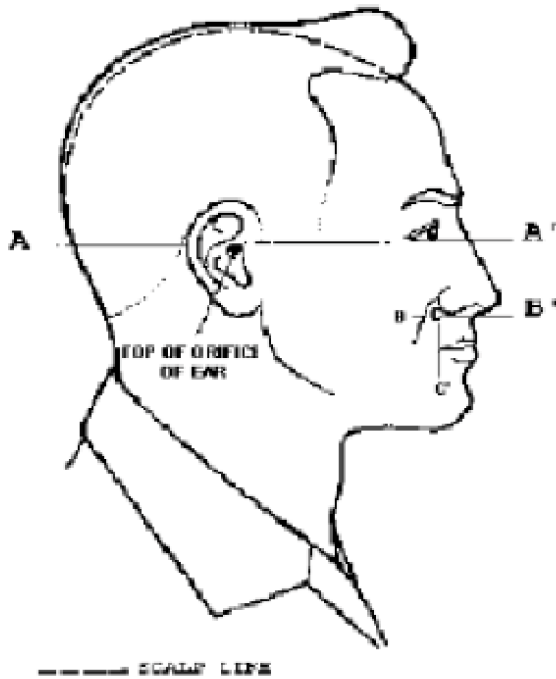

Figure 1-2  
Male Grooming Standards (Side View)

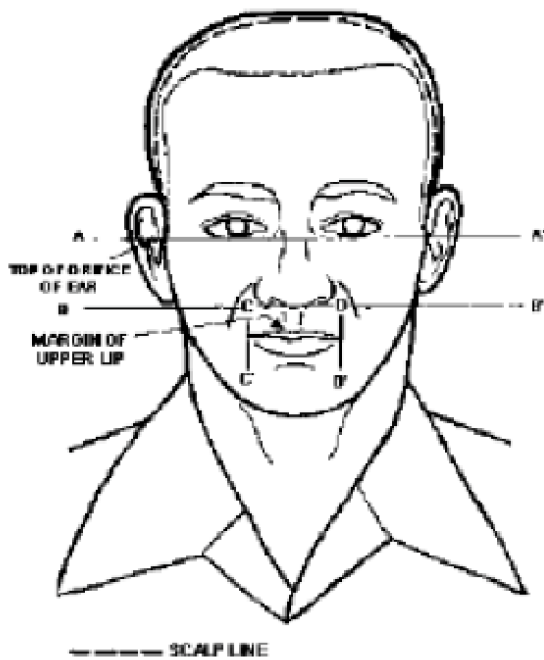

Figure 1-1  
Male Grooming Standards (Front View)

**Specific Female Cadet Grooming Guidelines.**

- **Authorized Female Hair Styles.**
- No minimum hair length to a maximum bulk of 3 ½ inches from scalp and allows proper wear of headgear. Hair must not exceed bulk and length standards and must not extend below the bottom of the collar. Headgear must fit properly. (Figure 2)



Figure 2.

- Hair will end above the bottom edge of collar and will not extend below an invisible line drawn parallel to the ground, both front to back and side to side.
- Bangs, or side-swiped hair will not touch either eyebrow, to include an invisible line drawn across eyebrows and parallel to the ground. (See Figure 3)
- When hair is in a bun, the bun must be a single bun; no wider than the width of the head and all loose ends must be tucked in and secured. (See Figure 3)



Figure 3.

- When hair is in a ponytail, it must be a single ponytail; that does not exceed bulk and length standards and does not extend below the bottom of the collar (except while in the PTU).
- When in doubt, assess correct length of hair with the cadet standing in the position of attention. The intent is for pinned-up hair to be styled in a manner

that prevents loose ends from extending upward on the head. For example, when using a clip or hairpins, hair will not present the appearance of a rooster tail. (Figure 4)

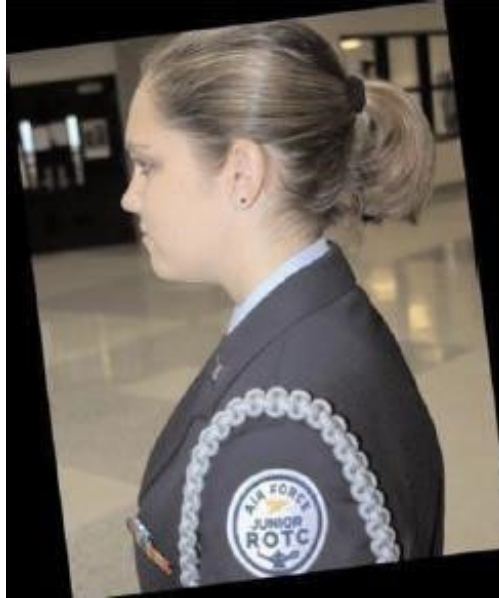

Figure 4.

- Hair accessories. If worn, black fabric scrunchies, hairpins, combs, clips, headbands, elastic bands and barrettes are authorized with all hair colors. Accessories that match the hair color (i.e., blonde, brunette, natural red, black) are also authorized. Hair must still comply with bulk and appearance standards. Headgear must fit properly.
- Headbands or fabric scrunchies will not exceed one-inch in width. Ornaments are not authorized (i.e., ribbons, beads, jeweled pins).



Figure 5.  
Example of an authorized scrunchy.

- Braids, twists, micro-braids, French braids, Dutch braids and cornrows are authorized. A braid or twist is two or more portions of interwoven hair. (Figure 6)



Figure 6. Authorized Braids

- If adding additional hair, it must be a natural looking color, similar to the individual's hair color. It must be conservative (moderate, being within reasonable limits; not excessive or extreme) and not present a faddish appearances. Hair color, highlights, lowlights, and frosting will not be faddish or extreme and will be natural looking hair color, similar to the individual's hair color (e.g. black, brunette, blond, natural red, and grey).
- **Unauthorized. Locs and shaved heads.** Locs are defined as portions of hair that have been intentionally or unintentionally fused together to form a loc or locs. Shaved heads are defined as complete removal of all hair to the skin on the head or portions of the head. Figure 7. Mohawk, mullet or etched designs are not allowed.

Figure 7.



Unauthorized Female Hairstyles: Locs & shaved heads

### Female Cadets

- Hair must be styled to present a professional appearance. Allow the wear of conservative hairpins, combs, headbands, elastic bands and barrettes. Hair pins and bands must match hair color. Long hair will be secured with no loose ends. However, bangs, if worn, will not touch the eyebrows.
- Hair will not be worn in an extreme or faddish style. It will not extend below any side of an invisible line drawn parallel to the ground at the bottom edge of the shirt collar regardless of length. Scrunchies are authorized as a hair accessory; however, ribbons, beads, and jeweled pins are not authorized as hair accessories. Female cadets are prohibited from wearing them in uniform. They may not have shaved heads, military high-and-tight or flat tops haircuts. Hair will not exceed 3 ½ inches in bulk, or prevent the proper wear of headgear.
- Unnatural hair color and other bizarre hairstyles are not authorized. Hair color/high lights/frosting will not be faddish and will be natural looking (Blonde, Brunette, Natural Red, Black, or Gray).
- Earrings will be small round or square white diamond, gold, white pearl, or silver earrings with any uniform combination and worn as a set. If member has multiple holes only one set of earrings will be worn in the lower earlobe. Earrings must match and fit tightly without extending below the earlobe. Clip-ons must fit tightly and may not extend below the earlobe unless the piece extending is the connecting band on the clip. Wearing multiple earrings in a single ear or any type of cartilage piercings is not allowed.
- Absolutely no body piercing jewelry or multiple earrings/gauges are allowed in accordance with KISD policy (e.g., no tongue, nose, eyebrow, mouth jewelry, upper ear, etc.), anytime during the school day or during any school function, especially while in uniform. Any cadet in violation of this rule may be considered possible probation and subsequent removal from AFJROTC.
- Fingernails cannot extend more than ¼ inch from the end of the finger and cannot be painted in bright or dark colors of any kind. French manicures and natural colored polished are preferred. If used, nail polish must be a single color (and should complement skin tone) or French manicure style. Some examples of extreme colors include but are not limited to, purple, gold, blue, black, bright red and fluorescent colors. Glitter mixed in with any color is unauthorized.
- Cosmetics must be conservative and in good taste.



## CHAPTER 6

### THE UNITED STATES AIR FORCE UNIFORM

1. The reputation of the United States Air Force as a professional military organization is known worldwide. Since the uniform you wear is a symbol of reputation, each cadet in the AFJROTC program at Tivy High School must wear it properly. The importance of this cannot be over-emphasized, since the uniform, except for insignia, rank and patches, is the very same uniform worn by active duty Air Force airmen.
2. Protecting government property is each cadet's responsibility. All uniform items, AFJROTC textbooks, computers, etc. are equipment items loaned to you by the Air Force. Uniform and equipment items must be accounted for at all times. Also, any equipment belonging to Tivy High School and issued to cadets, must be protected and maintained.
3. At the time you are issued your uniform and equipment you will be required to sign a Uniform Issue Receipt, see attachment 2, and place your initials on each line for individual items of uniform and equipment issued. Each item then becomes your personal responsibility. If you lose an item, or willfully or negligently destroy it, you will be required to pay for it. At the time of issue of uniforms and equipment you will be advised of the cost of each item.
4. As a minimum one complete uniform with all accessories and insignia is issued to each cadet. It is most important that each cadet understand that all items of the uniform or equipment (with the exception of shoes and socks) must be returned or paid for before the end of the school year. **Uniforms must be returned dry-cleaned and/or laundered.** Neither the AFJROTC Certificate of Training nor the Certificate of Completion will be awarded until all uniform and equipment items have been turned in. In addition, a financial obligation will be incurred and must be paid before graduation, registration, or transfer of credit to another school or college admission. The cleaning fee for turning the uniform in dirty is \$30.00.
5. Each cadet will be issued the following items: Service dress coat, light weight jacket, pants/trousers, shirt/blouse, tie/tie tab, flight cap, shoes, nametags, and rank/ribbons (as earned).
6. To preclude unnecessary expense to the cadet and/or delay of receipt of grades or diploma, and to provide for efficient turn-in of uniforms and equipment, the following suggestions are offered.
  - Do not leave uniform items in unlocked lockers or unattended at school.
  - Do not lend uniform items to other cadets or persons.
  - Do not permit another cadet to turn in your uniform or equipment items.

- **Place your name on the inside of your flight cap for identification purposes.**
- Be alert for uniform or equipment items left or misplaced by another cadet. Turn in such items to an instructor.

## 7. UNIFORM WEAR

- a) AFJROTC uniforms will be issued to all cadets during the 1<sup>st</sup> six weeks grading period. All cadets will wear the uniform starting the 1<sup>st</sup> Wednesday of the 2<sup>nd</sup> six weeks grading period.
- b) Airmen Battle Uniform (ABU's) are allowed to be purchased by AS-2, AS-3, and AS-4 cadets. They can be worn two Wednesdays per month in place of the normal blue uniform wear or as directed by instructors.
- c) Cadets are authorized to wear a Flight Suit while enrolled in and after successful completion of Ground School. Flight Suits must be bought at the personal expense of the cadet.
- d) The Optional Cadet Uniform (OCU) consists of:
  - 1) Current Tivy AFJROTC polo shirt (tucked into the pants)
  - 2) Slacks, pants or school-appropriate jeans (without holes)
  - 3) Solid color belt (leather is preferred)
  - 4) Closed toe shoes
  - 5) During grooming inspection, cadets must have their hair up to grooming standards but may wear jewelry and have manicured nails.
  - 6) Hats will be authorized on a case by case basis for outside wear

The OCU will be worn as prescribed by the instructors and during certain events such as upperclassmen Curriculum in Action trips and the End of Year trip.

8. Wednesday of each week is uniform day unless you are instructed otherwise. The issued uniform will be worn all day unless an instructor has authorized a clothing change.
  - a. If you are found out of uniform without permission from the SASI/ASI, you will receive a zero (0) uniform grade for that day and be noted towards removal (after three incidents.) Failure to wear the uniform will result in the "Loss of Standing" or "Not in Good Standing" status.
  - b. During the period of time a cadet is "Not in Good Standing" they are NOT eligible for AFJROTC trips or allowed to attend the Military Ball.
  - c. To regain "Good Standing" a cadet must successfully wear the uniform on the next two scheduled wear dates. If a cadet is dual enrolled (taking two classes of Aerospace Science) the uniform will be graded during both classes.
  - d. Assignment to ISS will result in 4 weeks of Loss of Standing and a 60 for the leadership grade for that week. Suspension from school will result in a minimum of 6 weeks of Loss of Standing and could result in removal from AFJROTC.

- e. If a cadet is found wearing a partial uniform (i.e. white t-shirt, blue pants, and shoes without the blue shirt on) they will receive a “0” for that week’s Uniform grade grading period.
9. A three-strike rule will be enforced for uniform wear; meaning failure to wear uniform three times, will likely result in probation and subsequent removal from AFJROTC. The SASI will make the final removal determination based on the individual circumstances.

### Male Cadet Uniform

- a. **Flight Cap:** Wear cap tilted slightly to your right, with the vertical crease in the line with the center of the forehead, in a straight line with the nose. It will be approximately 1 inch from the eyebrows. Do not crush the crown, front, or back of the cap. It is always removed indoors unless you are under arms. When not worn, the flight cap should be tucked under the belt on the wearer’s left side between the first and second belt loops; cap will not fold over belt. The wearer must write their name on the inside of the cap.
- b. **Beret:** Berets may be worn if the cadet is on a team or a current member of the corps staff. Berets must be centered over the left eye and the excess of the beret must be flattened towards the right side of the wearer. Flashes are not authorized on the berets.
- c. **Shirt:** Generally worn with collar open, unless instructed otherwise. Wear a white undershirt (V-neck or athletic style) with all service and dress uniforms; the white crew-neck style undershirt is authorized only when wearing closed collar service and dress uniforms. Undershirt will be tucked into trousers. The sleeves of the undershirt must not protrude below the shirt. The shirttail is pulled into the trousers tightly and tucked at the sides to make it nearly form fitting. The only creases on the shirt are down the sides of the sleeves. Military creases are not authorized.
- d. **Trousers:** Trim and fitted with no bunching at the waist or bagging at the seat. The front of the trouser leg must rest on the front of the shoe, with a slight break in the crease. The back of the trousers must be approximately 7/8 of an inch longer than the front. The rear button of the trousers will be buttoned at all times. Articles carried in the pockets should not be visible.
- e. **Belt and Buckle:** The tip and buckle of the belt must have a chrome-like finish. When properly worn, the tip of the belt extends beyond the buckle facing, to the wearer’s left. No blue fabric will show between the buckle and belt tip. You must have a visible gig-line. This is a line that runs down the right front edge of your shirt, belt buckle, and fly. The belt is threaded through the loops to your left.
- f. **Service Dress Coat:** The outside pockets of the coat are for decoration only. Nothing should be carried in them. Use the inside pocket for carrying small, flat items. All outside pockets and buttons will be secured at all times. The coat may be removed in the classroom, only with the instructor’s permission. If the coat is removed in the classroom, it will be carefully

draped over the back of the chair. The tie/tie tab will not be removed or loosened even though the coat is removed. The coat will be donned and buttoned before leaving the classroom. Rank and ribbons are mandatory; ribbons should be centered and grounded over pocket. The blue name tag is not worn on this jacket.

- g. **Lightweight Jacket:** Partially lined and water repellent. It is waist length with a zipper front and two slanted pockets. It has knitted cuffs and waistband. The jacket may be worn over all blue shirts. The jacket must be zipped up at least halfway when worn.

### Female Cadet Uniform

- a. **Flight Cap:** Worn tilted toward the wearer's right, with the vertical crease at the center of the forehead in a straight line with the nose, approximately 1-inch above the eyebrows. Hair may protrude in the front of the cap, but must not touch the eyebrows. Do not crush the crown, front, or back of the cap. It is always removed indoors unless you are under arms. When not worn, the flight cap should be tucked under the belt on the wearer's left side between the 1st and 2nd belt loops; cap will not fold over belt.
- b. **Blouse:** Generally worn with collar open, unless instructed otherwise. Wearing a white bra is mandatory, however females may wear a white undershirt (V-neck or athletic style) with all service and dress uniforms; the white crew-neck style undershirt is authorized only when wearing closed collar service and dress uniforms. Undershirt will be tucked into the pants. The sleeves of the undershirt must not protrude below the shirt. The shirttail is pulled into the pants tightly and tucked at the sides to make it nearly form fitting. The only creases on the shirt are down the sides of the sleeves, military creases are not authorized.
- c. **Pants:** Trim and fitted with no bunching at the waist or bagging at the seat. The front of the pant leg must rest on the front of the shoe, with a slight break in the crease. The back of the pant must be approximately 7/8 of an inch longer than the front. Articles carried in the pockets should not be visible.
- d. **Belt and Buckle:** The tip and buckle of the belt must have a chrome-like finish. When properly worn, the tip of the belt extends beyond the buckle facing, the wearer's right. No blue fabric will show between the buckle and belt tip. You must have a visible gig-line. This is a line that runs down the right front edge of your shirt, belt buckle, and fly. The belt is threaded through the loops to your right.
- e. **Service Dress Coat:** The outside pockets of the coat are for decoration only. Nothing should be carried in them. Use the inside pocket for carrying small, flat items. All outside pockets and buttons will be secure at all times. The coat may be removed in the classroom, with instructor's permission. If

the coat is removed in the classroom, it will be carefully draped over the back of the chair. The tie/tie tab will not be removed or loosened even though the coat is removed. The coat will be donned and buttoned before leaving the classroom. Rank and ribbons are mandatory; ribbons should be centered and grounded over pocket. The blue name tag is not worn on this jacket.

- f. **Lightweight Jacket:** Partially lined and water repellent. It is waist length with a zipper front and two slanted pockets. It has knitted cuffs and waistband. The jacket may be worn over all blue shirts. If worn, the jacket must be at least halfway zipped.

## 10. Uniform Care and Cleaning.

- **(Main Street Cleaners @ 1008 Main Street - by the Medicine Stop)** is our contract tailor shop and provides all uniform alterations. **AFJROTC will pay for the alterations accomplished at this location – cadets will be given a voucher to get the work done.** An instructor will provide the cadet with a signed uniform alteration voucher for the work to be done. **Only Main Street Cleaners is allowed to do alterations. You will be responsible for any damages to the uniform from unauthorized tailoring.**
- **The service coat, trousers/pants, lightweight jacket (including liner), flight cap, tie/tie-tab must be commercially dry cleaned. Home dry cleaning products do not work and must not be used on these uniform items. Shirts/blouses may be laundered commercially, however they may be laundered at home, but must be ironed to remove wrinkles.**
- When uniform items no longer fit, you must have them dry cleaned/laundered and returned to an instructor for exchange with cleaning tags attached. No exchanges will be made for items that have not been commercially dry cleaned. Shirts/blouses laundered at home must be ironed to remove wrinkles before turn in.
- Clothing items that can no longer be worn or become otherwise unserviceable should be turned into an instructor as soon as possible. If the unserviceable condition is due to fair wear and tear in normal use, the items will be replaced at no cost. Items of clothing that do not fit properly should be dry cleaned/laundered and exchanged.
- When turning in or exchanging uniform items or other equipment, communicate with the instructors.

**NOTE:** Airman Battle Uniforms (ABUs) are NOT issued in the TX-20063 AFJROTC.

### Miscellaneous

- **Socks:** Are mandatory and must be black. Ankle socks are NOT authorized.
- **Under shirts:** Males are required to wear white V-neck T-shirts underneath the blue Air Force issued shirt. The T-shirt protects the garment and allows for more comfortable wear of the Air Force shirt. The unit cannot provide undershirts to cadets so this will be a cadet/family expense.
- **Pockets:** Will be buttoned. Hands should be kept out of uniform pockets. If your hands are cold wear plain, black gloves. Avoid carrying bulky items in the pockets which distort the appearance of the uniform.
- **Shoes:** Will be laced to the top and shined to a high gloss at all times. Be sure to check the edges of the heels and soles. Corfam (patent leather) shoes are an optional personal expense for AS-4 cadets only.
- **Name Tags:** The name tag is worn over the right breast pocket, parallel and centered above the top seam of the pocket on the male uniform. For the female blouse, the name tag is centered on the right side between the arm sleeve and the button line, and placed even with or 1 ½ inches higher or lower than the first exposed button.
- **Ribbons:** Center and grounded above the left breast pocket, parallel and centered above the top seam of the pocket on the male uniform. Females will center their ribbons on the left side of the blouse aligning the bottom of the ribbons with the bottom of the name tag. Center is measured between the arm sleeve seam and the button line of the blouse.
- **Shoulder cords:** One shoulder cord is authorized to be worn only on the left shoulder, cord must be grounded to the epaulet, the shoulder cord cannot be worn on ABU's.
- Trim all loose strings and frayed seams on the uniform
- See instructor to replace missing buttons promptly.
- Develop the habit of carrying books, book bags and other objects in the left hand or on the left shoulder to free the right hand for saluting when outdoors.
- One bracelet (no dangling charms or devices) which is conservative, and ½ inch wide or less in width can be worn while in uniform. Rings (maximum of 3) may be worn. Thumb rings do not present a professional appearance, and will not be worn in uniform.  
Necklaces, cloth/string wristbands, pendants, ankle bracelets, and other visible adornments are prohibited while in uniform. Bracelets that support a cause, philosophy, individual or group are not authorized. Traditional POW/MIA bracelets and Medical Alert bracelets are authorized. Watches must be conservative and only one can be worn around the wrist while in uniform. Conservative examples (not all inclusive) are solid color black, brown, silver or

gold. Prohibited examples are diamond covered, neon, bright colors, and bands that exceed 1-inch in width.

- Uniform must not be worn if hitchhiking.
- Approved sunglasses may be worn, but not in formation or inside a building. Mirrored or colored lenses are not authorized.
- Only authorized uniform items will be worn. Do not mix any uniform items with civilian clothing.
- Flight caps or berets will be worn while outside.
- Headphones will not be worn while in uniform (or in hallways or class either). It is unprofessional and is a potential safety risk.

## CHAPTER 7

### ***GRADING SYSTEM AND ASSIGNMENT MAKE-UP POLICY***

1. Tivy High School uses a numerical grade system. This system, as applied to the AFJROTC program, is shown below:

100-90% = A, 89-80% = B, 79-75% = C, 74-70% = D, 69-0% = F

NOTE: AFJROTC Instructors will be available to discuss your work with you or your parent/guardian any school day. **Should your parents/guardians wish to make an appointment, please send a note, e-mail, or call (830) 257-2212 Ext 3615 (SASI–Col Woods) or Ext 3616 (ASI – CMSgt Galifaro).**

**The instructors conference period is period 7, from 2:30 to 3:25 p.m.**

2. Grading is based on a 100% System and cadet performance will be tabulated in five areas.

<u>Area</u>	<u>Percent</u>
• Academic Tests & Quizzes (per event)	25%
• Uniform Wear (per event)	25%
• Daily Work (weekly grade)	20%
• Wellness (weekly grade)	20%
• Activity (6-week grade)	10%

All components of the AFJROTC curriculum (chapters 3 & 15) are reflected in each grading area.

**Academic Tests & Quizzes.** Tests and quizzes are usually announced, but occasionally a surprise pop quiz will be given. Composition of tests and quizzes will be in of any combination of multiple-choice, true-false, completion, matching, short answer or essay questions. Sufficient time will be given to permit everyone to complete all tests and quizzes. Tests and quizzes may be critiqued in class after they have been graded.

**Uniform Wear. The uniform wear day for the TX-20063<sup>rd</sup> is Wednesday.**

After uniform issue is completed, a date will be assigned to be the “1<sup>st</sup> Uniform Wear Day.” All cadets will be required to wear the uniform on that day and every subsequent Wednesday. On rare occasions, the uniform wear day may be changed depending on class schedule (for example, if the Veteran’s Day Ceremony is on a Monday, the uniform day for that week would be changed to Monday). Be advised the Corps will be notified well in advance of any changes in the uniform wear day for a particular week. **Reference Chapter 6, Para 9 for specific uniform wear requirements.**



Title X (10) U.S.C. Federal Law establishing the AFJROTC program and the contract between the Kerrville ISD and AFJROTC requires all cadets wear the uniform **at least one day per week for the entire school day to participate in the program.**

**Daily Work:** Includes class participation and leadership/followership. Leadership / followership grades apply to the “Daily Work” area in the overall six-week grade. Deductions are taken on the day of the infraction. See Attachment 1 for an example of this score sheet.

NOTE: Failure to wear the uniform will result in a “0” for the weekly Daily Work grade in the week the uniform should have been worn, along with a Uniform wear grade of “0.” If absent on uniform day, the next day back to school is the uniform make-up day. The uniform must be worn all school day (7:50 a.m. – 3:25 p.m.).

**Wellness:** Wellness is one day per week, usually Friday, consisting of academics and leadership performance (exercises and organized team) activities. Exercises are based on the President’s Physical Fitness Program. Team activities give cadets a chance to demonstrate and practice leadership skills in a competitive group environment. To enroll in AFJROTC, cadets must be physically able to participate in a regular high school PE class. Therefore, failure to participate, including “unexcused absences” will result in a “0” for the weekly wellness grade. An “excused” absence will be annotated as a “no count” wellness grade and does not affect the overall grade for the grading period. The AS-4 flight may be exempt from this if Corps work needs to be done. Failure to wear PT gear or PT shoes will result in a 70 (1<sup>st</sup> offense), a 50 (2<sup>nd</sup> offense), or a 0 (3<sup>rd</sup> or more offense).

**Activity:** Tivy’s AFJROTC program hosts many Leadership Development Requirements (LDRs) which are considered required activities during the course of the school year. These opportunities are announced well ahead of time. Cadets must participate in one event each six weeks. Failure to complete the requirement will result in a “0” for your Activity Grade.

Activities include (but are not limited to): Community Service Projects, Drill Team, Color Guard, Rocketry Team, Awareness Presentation Team (APT), KHAS Project, PT Team, Quadcopter Team, Veterans Day Ceremony, Football Flag Runner Team, Antler Tram, Push-up Squad, Field Day Committee, Antler Classic Rocketry and Quadcopter Competitions, Unit Picnic, Unit Dances, Adopt-a-Highway Community Service, and the Bataan Death March memorial event.

### 3. Assignment Make Up

- a. If you miss a day in AFJROTC and you missed a graded event, the **MAKE UP WORK IS YOUR RESPONSIBILITY**.
- b. After an absence, on the day of your return, you are expected to ask your instructor at the beginning of the class, if there is anything that needs to be made up. If you do not ask, and a quiz, test, inspection, etc., was given during your absence, expect to take a zero “0” for that grade. You will normally make up the work within two AFJROTC class days after the day of absence. The idea is to make up work as quickly and reasonably possible after an absence; do not delay it indefinitely. If you are not sure whether something was missed, ask your instructor.
- c. In the event you are absent two or more days, discuss with the instructor when you can reasonably be ready to take quizzes or inspections, etc. Do not ignore the subject or you will not receive credit for the missed work.
- d. If you are absent from school on uniform inspection day (Wednesday or as assigned), you have until the following class day to make up the inspection. For instance: if you miss a Wednesday uniform, you must make up the inspection on Thursday or the next day that you are back to school.
- e. Failure to make up a uniform inspection results in a “0” for the uniform major grade for that week and a “0” in daily work, loss of “good standing” and possible disciplinary action (See Chapter D).
- f. If you are absent Wednesday and Thursday of that week, your uniform inspection will be made up on the following Monday. Uniform make ups will not be conducted on Wellness/PT Days (Fridays).
- g. Excuses such as “I did not know what uniform to wear” or “My uniform is in the dry cleaners” will not be accepted. It is your responsibility to wear the uniform as assigned on the proper day. This means you must plan to have the uniform ready. If you fail to wear the uniform on the assigned day, and you were physically at school on Wednesday (or assigned day), your make-up grade will start with “70” and any discrepancies will be added and subtracted from the maximum score of “70.”
- h. Skipping JROTC class to avoid the uniform inspection will result in a “0” for the major grade that week. Instructors check to see if cadets who are absent in JROTC, are also absent in other classes that same day and regularly converse with other teachers. They will know and find out if you try this and your grade will reflect it.
- i. Academic grades and leadership performance are key factors in the selection of cadets for promotion, awards, decorations, competition for scholarships, summer leadership school and academy nominations.

## CHAPTER 8

### ***AFJROTC LEADERSHIP DEVELOPMENT REQUIREMENTS (LDRs) TEAMS AND MEETINGS***

**1. Color Guard Team:** This elite group has the honor of presenting and posting the National and State colors (e.g. Flags) at important school and community programs. Teams also compete at area drill competitions. Team members represent Tivy High School, Air Force Junior ROTC, and the community throughout the state. Members of the Color Guard are awarded a distinctive blue and black shoulder cord. All cadet staff members are expected to perform color guard details.

**2. Armed Drill Team:** Precision and execution of marquee movements are the hallmark of this team. Team members perform at community and school functions providing demonstrations that rival active duty military drill teams. Trust and dedication are major requirements to becoming a member and must be shown by all team members.

**3. Unarmed Drill Team:** Rhythm and creativity are essential to members being selected to this exciting team. This team has opportunity to create style and charisma with their dance moves and precise choreography. Practice is demanding yet rewarding when the team chemistry flows through the dance.

**4. Saber Team & POW/MIA Detail:** Military precision, attention to detail and a propensity to safely handle a military Saber are requirements for this elite team of cadets.

**5. Physical Training Team:** Endurance, and competitive drive and desire are requirements for being a physical fitness team member. Running, sit-ups, chin-ups, and push-ups are required at competition and this is what the team will focus on during training. Cadets maintain a record of training and analyze training improvement techniques. Self-motivation and team morale is essential to team each member's success.

**6. Kitty Hawk Air Society (KHAS):** This team is an academic honor society that promotes high academic standards, participates in school and community service projects, promotes self- confidence and initiative, develops leadership abilities, encourages academic excellence through tutoring, and assists in educational development in the post-high school years. Once inducted, team members are authorized to wear the KHAS badge. The KHAS meetings will be held periodically during the school year. AFJROTC Seniors who are members of the KHAS will be awarded the KHAS Silver and Purple Cords to be worn with their cap and gown for graduation.

**7. Model Rocketry Team:** The model rocketry team is for cadets interested in constructing and flying model rockets. The team represents the TX-20063<sup>rd</sup> in model rocketry competitions around the state.

**8. Awareness Presentation Team (APT):** Team members represent Tivy AFJROTC during several elementary school visits throughout the school year. They give presentations and perform different skits with selected themes such as drug awareness, Halloween Safety, and Summer and Spring Break Safety. When a cadet has completed three presentations he or she will be awarded the APT badge. APT meetings will be held periodically during the school year.

**9. Quadcopter / Drone Flight Training Team:** The purpose of this team is to provide practical flight application with hands-on training using computer simulations and a variety of quadcopters. It will reinforce science, technology, mathematics and engineering objectives of the curriculum.

**10. Flag Running Team:** The purpose of this team is to raise school morale at home and away football games by running school flags at kickoff, half time, and after each touchdown.

**11. Antler Tram Team:** The purpose of this team is to provide service assistance in parking and escorting guests to shuttles at all home football games.

**12. Strategic Gaming Team:** The purpose of this team is to utilize board games to develop higher level thought and planning skills that require participating cadets to develop individual and team strategies to win the games.

**13. Flag Detail Team:** This team is responsible for taking care of the flags at the front entrance of THS and lowering the flags to half-mast when notifications direct. Members of this detail who perform 3 or more details, will earn the Patriotic Flag Ribbon.

**Letterman Jackets:** Cadets will be able to earn a letter jacket through AFJROTC.

However, they must meet the following criteria:

- Have successfully completed two full **academic** years of AFJROTC at Tivy High School
- Be enrolled in a 3<sup>rd</sup> year of JROTC (i.e. be a Junior or Senior)
- Be in good academic standing with at least a “B” average in AFJROTC
- Display good citizenship and be a positive role model in all classes as evidenced by
  - No conduct grade below “S” (Satisfactory)
  - No suspensions (ISS or OSS) in the year the jacket is earned
  - No removal from any position or temporary rank in AFJROTC in the year the jacket is to be issued
  - No AFJROTC Honor Code violations

- ☐ No Cadet Probation in the year prior to or the year when jacket is earned
- ☐ No behavior that reflects negatively on the AFJROTC program
- ☐ Accumulate 3,000 letterman jacket points from the activities listed in (Attachment 3)
- ☐ Instructors are the final determination authority on all letterman jackets

When eligible, cadets will be notified and given an order form for the jacket and patches. The jacket, the “T” letter on front and the 14-inch Air Force Wings Patch for the back of the jacket and all other custom selections and embroidery will be 100% paid for by the cadet. Unit funds will not be used for this expense.

**NOTE 1:** Failure to maintain the qualifying criteria between the time the jacket is ordered and the day it is issued will result in the jacket being withheld from the cadet pending a review by the SASI. Depending on the circumstances, the jacket may be withheld for a designated period of time or, in the case of grievous violations, a cadet may be denied receipt of the JROTC Letterman Jacket altogether. Cadets disqualified from receiving the JROTC Letterman Jacket may **NOT** be entitled to a refund of money.

**NOTE 2:** Cadets must be at least a junior and enrolled in the JROTC program and meet all other published criteria to receive a Tivy JROTC Letterman Jacket.

**NOTE 3:** Only AFJROTC sponsored service projects performed as a TX-20063rd Corps can be counted for Letterman Points. Instructors can award up to 500 points per school year to a cadet(s) that have performed above and beyond what is normally expected. After a cadet earns 3,000 Letterman Points, and stays in “good-standing” in the year prior to and the year the jacket is earned, cadets earn the opportunity to pay for and get their JROTC Letterman Jacket. This jacket expense is a 100% cadet expense and is not unit funded. Final Letterman Jacket eligibility determination is at instructor discretion.

**14. Curriculum in Action Trips (Field Trips):** In addition to normal classroom activities, cadets will also have the opportunity to go on several field trips throughout the year. Cadets must be “In Good Standing” to attend AFJROTC field trips. **A cadet’s “Loss of Good Standing” occurs when disciplinary action is administered by a principal, administrator, AFJROTC Instructor or Cadet Discipline Board. See Chapter D**

**15. ROTC Dance(s):** Each semester, cadets have the opportunity to attend AFJROTC hosted dances. Cadets must be in good standing to attend and meet the requirements as prescribed by the letters given out prior to these dances. Previously enrolled cadets may attend if invited as a guest of a currently enrolled cadet in good

standing. Note: Cadets previously in AFJROTC must have departed in good standing and must be approved by the SASI and ASI in order to attend the dance.

**16. Staff Meetings:** The Corps Commander will hold weekly Corps Staff meetings and a Commander's Call each 6-weeks grading period throughout the school year. Corps staff meetings are held before school normally at 7:20 a.m. on uniform days. All cadets in leadership positions are required to attend the weekly meeting. All such staff meetings provide the opportunity for face-to-face communication between the commander and staff. They are also vehicles for group problem solving and allow the cadet staff to participate in Corps activity planning.

- All meetings will begin and end with the staff being called to attention. The **Corps Commander** will give the command "seats" and the meeting will begin. Commanders and staff officers will brief on plans, programs, and the unit's progress, identifying and discussing problem areas. Staff officers will brief the commander on their respective areas, identifying progress and discussing problem areas.
- If the **Corps Commander** is unavailable, the **Vice Corps Commander** will run the Corps Staff meeting or Commander's Call. If both are unavailable, the Deputy Commander for Training (DCT) will run the meeting.
- The **Corps Information Officer** will serve as a recorder and prepare a report of each meeting detailing discussion reached, actions taken, assignments made, etc. The report will be submitted through the Corps Commander, to the SASI for approval. The classroom will have a copy of the minutes posted on the bulletin board to allow cadets who were absent an opportunity to see what new business and upcoming events were discussed at the meeting.
- The **Senior Flight Commander/Staff Information Officer** will take attendance and provide a listing of absentees to the SASI/ASI. Absences are excused only by making prior arrangements with the Corps Commander, Vice Commander a Deputy Corps Commanders or the Senior Enlisted Advisor (SEA). Unexcused absences reflect a lack of discipline, commitment and leadership and can result in disciplinary action to include reduction in rank (demotion) and loss of the individual's Corps, Flight, or Team position or job.  
**(See Chapter D)**
- The appropriate Deputy Commander will follow up to ensure that the designated cadets accomplish actions as directed during the staff meetings.

- The staff meeting will be under the cadet’s control and military courtesies will be followed at all times. Instructors will be present to ensure all AFJROTC operations and activities do not conflict with THS and KISD guidelines and provide oversight, advice and approval (as required).
- The Chief Enlisted Advisor may conduct Enlisted Advisory Council meetings once each six weeks grading period, as required.

• **CHAPTER 9**

**TX-20063 ORGANIZATIONAL CHARTS**

**Corps Senior Staff**

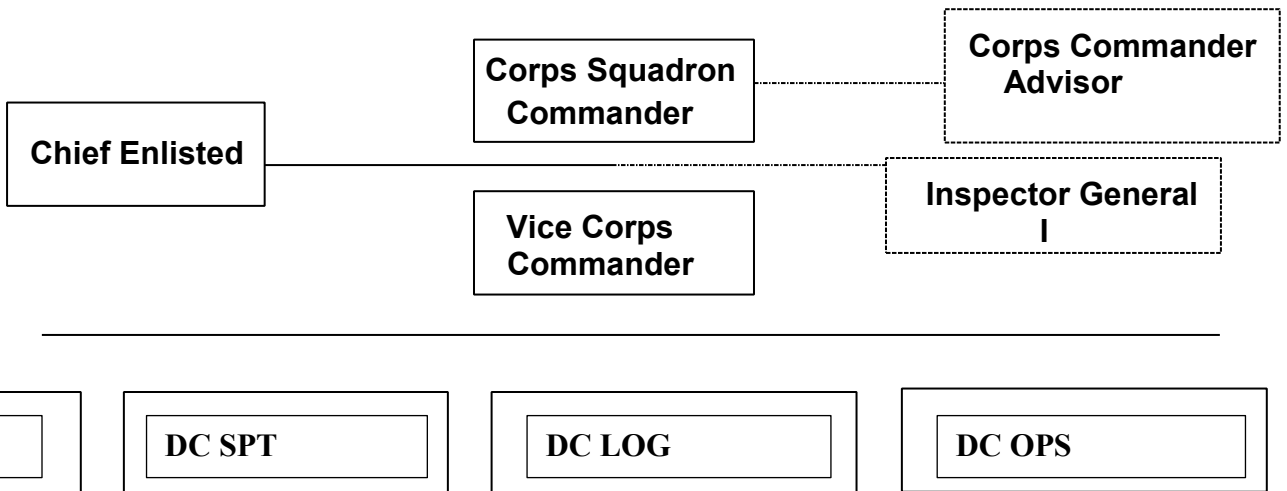

## Corps Command Staff

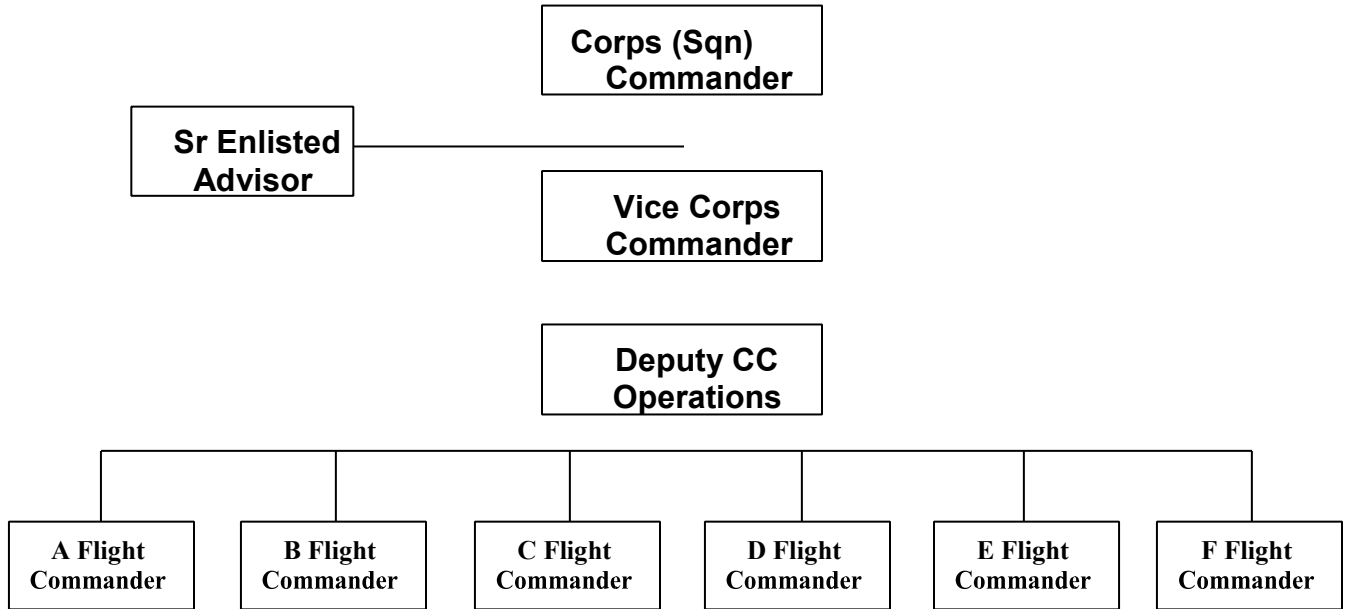

## Corps Administrative Staff (Corps Staff)

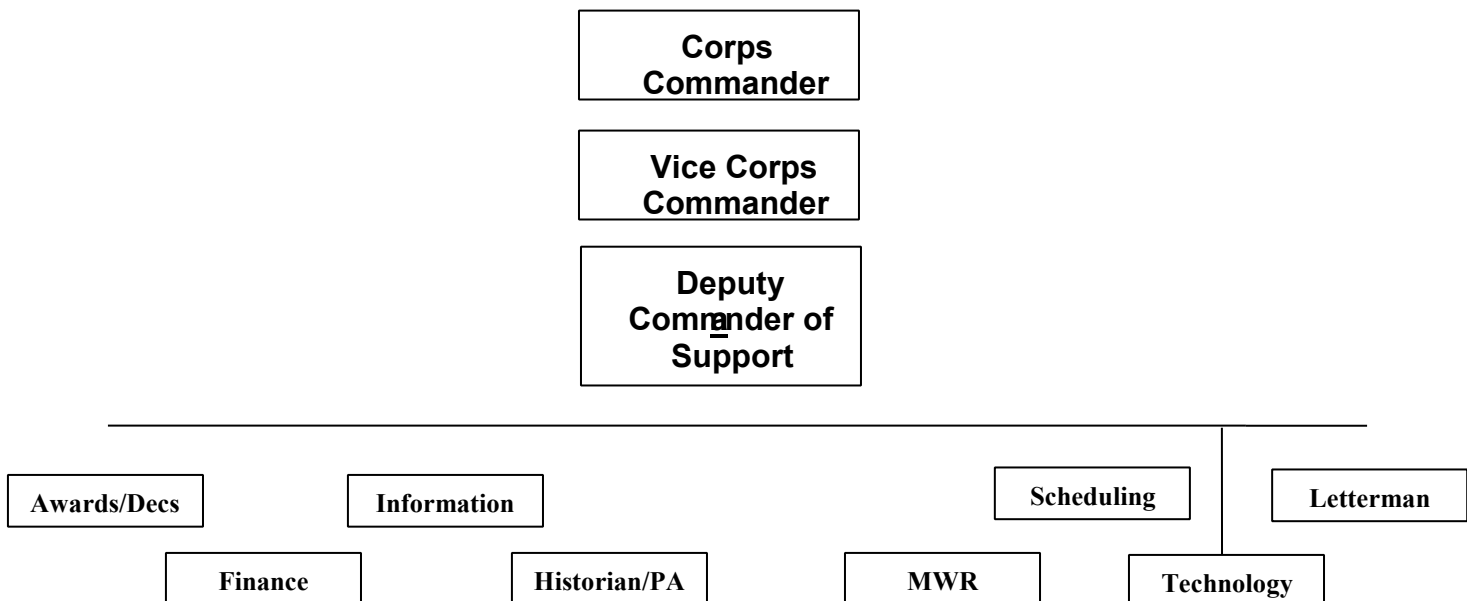



# Co-Curricular

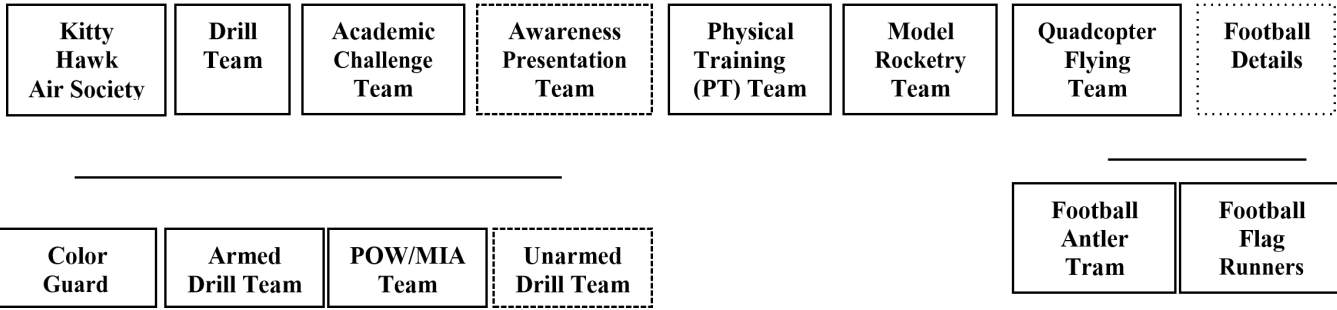

## TX-20063<sup>RD</sup> Flight Staff

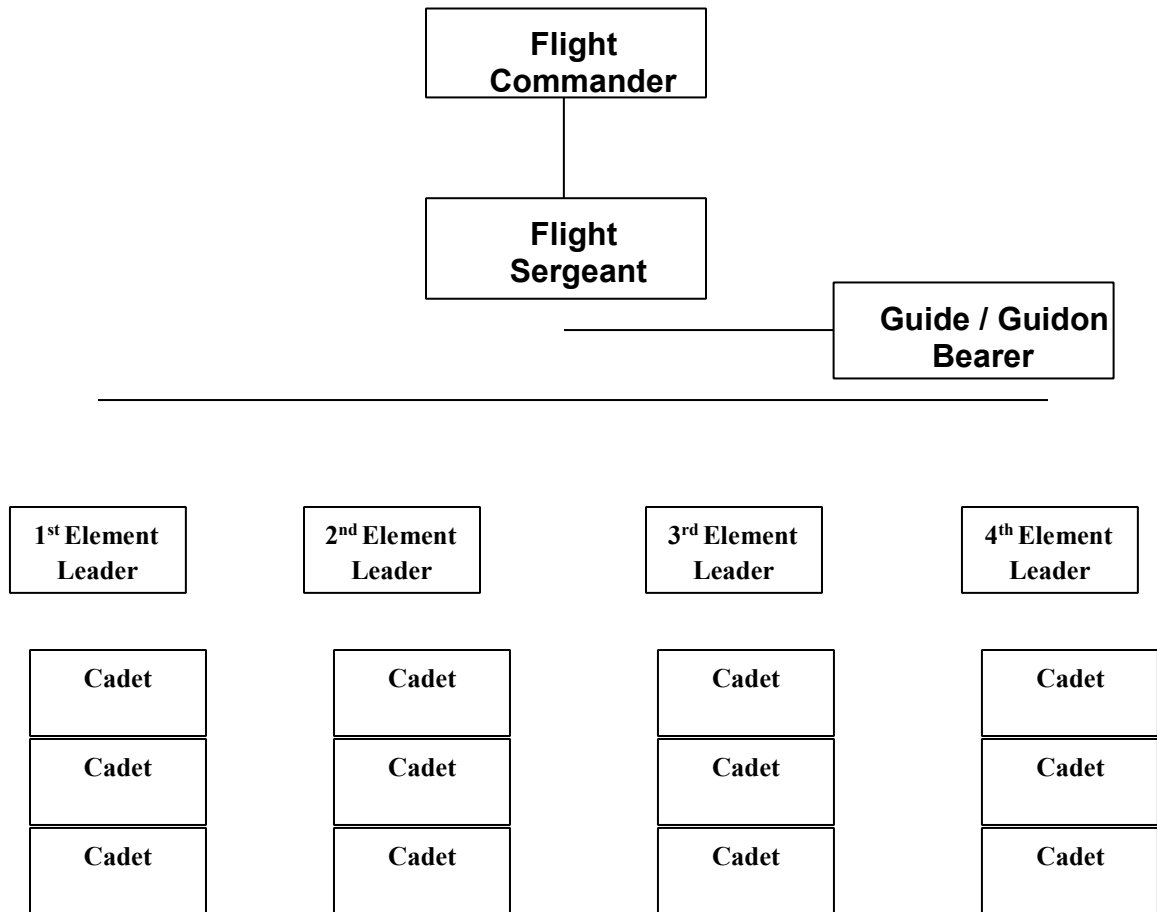

### CHAPTER 10

## ***CADET PROMOTIONS***

1. TX-20063<sup>rd</sup> promotions are based on demonstrated potential to serve in the higher rank, maturity, leadership capability, and performance. Awards and decorations are earned for outstanding performance in accordance with AFJROTC written guidance and TX-20063<sup>rd</sup> policy / procedures. Instructors are the final cadet rank determination authority.
2. **Ranks:** Rank is awarded based on a cadet's leadership potential and performance. It is earned and is evidence of promotion and standing among cadets. It reflects a cadet's increase in maturity, ability, and willingness to accept additional leadership responsibility. Promotions can occur throughout the year based on performance and position vacancies. They will be made with the recommendation of the cadet chain of command, concurrence of the ASI, and approval of the SASI. Items considered in reviewing cadets for promotion are: academic grades, demonstrated leadership potential, extra and co-curricular activities, motivation and desire for increased responsibility, and the cadet's performance and acceptance of responsibility.
3. **Permanent Promotion:** All cadets will have permanent grade normally according to the number of years of AFJROTC successfully completed. Cadet Airman can be earned and awarded during the first year of AFJROTC, Cadet Airman First Class during the second year, Cadet Senior Airman the third year, and Cadet Staff Sergeant the fourth year. Permanent rank will be awarded based on satisfactory performance.
4. **Temporary Promotion:** Cadets may also receive a promotion to a temporary grade based on the level of assignment and position within the unit. These are, as the word implies, temporary, and will normally be removed if the cadet is no longer assigned to the position. The SASI may approve an exception to this AFJROTC policy for seniors in good standing who may then retain their "temporary" rank through graduation. The positions / grades authorized for each position are shown in the Unit Manning Document (UMD), Ch. 12. Promotions up to SrA are not limited in the number by the UMD.
5. **Promotion Quotas:** The number of cadets who can hold a particular grade is limited by the number stated in the UMD. The UMD clearly reflects the fewer number of slots for the higher grades. Promotion is a reward for a job well done and it is an expression of confidence in continued performance above the standard. Not every cadet can, or should, be promoted.
6. **Reduction in Grade/Demotions:** Cadets are subject to a reduction in grade at any time for failure to carry out responsibilities or meet established standards. In addition, cadet officers are expected to maintain passing grades in all subjects. Any cadet officer on the "**UIL Failure List**" (or Reporting Period Failure List) will be considered to be on probationary status, and will have one marking period to come off the "UIL" list or be demoted. Moreover,

inclusion on the “UIL” list cannot be repeated more than once during the school year. Cadet demotions may be administrative or corrective.

- **Administrative Demotions** are non-punitive and are made as required by the SASI to manage the Unit Manning Document authorizations in the Cadet Corps.

**NOTE:** A cadet who resigns from a leadership position and is unable, unwilling, or unqualified for another leadership position in the Corps will be administratively demoted to their permanent JROTC rank (based on their number of years in the program).

- **Corrective Demotions (for cause)** are made by the SASI whenever cadets fail to perform satisfactorily in the positions in which they have been entrusted.

7. **Future Promotions:** Cadets initially assigned to officer and NCO positions will not normally be appointed to the highest rank authorized for the position in the UMD to allow for future promotion based on performance.

8. **Cadet Officers:** Not every cadet will, or should be, promoted to officer grade. The Officer Corps will be comprised of those proven, dedicated cadets with a demonstrated interest and outstanding performance in AFJROTC. Cadet Officer Candidates must meet the following criteria.

- Successful completion of their first year of AFJROTC (AS 1).
- Successful completion of a summer Cadet Leadership Course (if possible).
- Assignment to an officer position with duties listed in the Unit Manning Document.

**NOTE:** The SASI may waive the criteria for unique circumstances.

9. **Cadet Position Rotation:** In order to provide leadership training and experience to a greater number of cadets, the cadet command and staff positions may be rotated during the school year. The rotation of various positions will be based on the positions available, individual cadet abilities, and cadet chain of command recommendations. Cadets may apply for command/staff positions through the cadet chain of command, starting with his or her flight commander. Cadet candidates for command/staff positions are carefully considered so that they may gain the greatest possible leadership experience and fulfill the responsibility of those positions. Personnel changes will be made whenever a cadet has demonstrated the ability to perform at a

higher level of responsibility or when performance is not up to an acceptable standard.

10. **Special Orders:** Promotions, demotions, and appointments to command or staff positions will be made by Special Orders drafted by the Personnel Officer, coordinated through the ASI, and signed by the Cadet Corps Commander and the SASI.

## CHAPTER 11

### ***JOB DESCRIPTIONS***

1. AFJROTC Instruction 36-2001 requires the SASI to write and make available to all cadets, job descriptions. The purpose of a job description is to outline the general duties and responsibilities of any particular leadership position in the Corps. As you are considering your goals in the AFJROTC, you should refer to the job descriptions to see those areas that interest you. A note of caution – please do not set a goal you are not willing to work for. Remember – each leadership position has responsibilities and a rank that will allow a cadet to carry out these responsibilities. Your goal should not be to “be a cadet Captain,” but should be to fill a leadership position that has a rank of cadet Captain.
2. All Cadet Squadron Staff OIC’s report directly to the Deputy Commander of Support. All information, reports, orders, newsletters, etc. must be received and approved by the Deputy Commander. Officers will be required to assign duties and responsibilities to their NCOIC’s with specific due dates prior to the Deputy Commander’s suspense. Follow up requests and actions are the responsibility of the NCOIC. Use the appropriate chain of command to request assistance within a flight when necessary. Communication is important between the OIC and NCOIC on all tasks.

### **CORPS (SQUADRON) COMMANDER IS RESPONSIBLE FOR:**

- Command and control of the Cadet Corps using the members of his/her staff and subordinate commanders.
- Keeping instructors updated on all activities in the Corps.
- Direct supervision of the Vice Group Commander, SEA and Deputies.
- Representing the Cadet Corps at all public and Corps related functions.
- The appearance, discipline, efficiency, training and conduct of the Corps.
- Conducting the Corps Disciplinary Board.
- Assisting the SASI and ASI as necessary. Ensure that all members of the Corps have the opportunity to develop leadership commensurate with their individual abilities.
- Establishing and posting the overall goals for the TX-20063<sup>rd</sup> Cadet Corps.
- Ensuring goals of subordinate commanders support the Corps Goals.
- Inspecting each staff function and activity as scheduled and discussing such inspections at scheduled staff meetings.
- Administering Cadet Corps activities according to JROTC principles & procedures.
- Compiling and maintaining a Continuity Binder for this position.

- Other duties as assigned.

**CORPS COMMANDER ADVISOR (Former Corps CC) IS RESPONSIBLE FOR:**

- Advising and assisting the Corps Commander (as needed).
- OIC for the Annual Awards Ceremony.
- Special projects as determined by the SASI and ASI.  
Compiling and maintaining a Continuity Binder for this position.
- Other duties as assigned.

Although the Corps Commander Advisor is NOT in any direct chain of command, they are to be treated with the respect their rank and former position commands.

**VICE SQUADRON COMMANDER IS RESPONSIBLE FOR:**

- Command and control of the Cadet Corps in the absence of the Corps Commander.
- Direct supervision of the Deputy Commanders for Training, Support and Operations.
- Officer in charge of preparing the unit for the annual Unit Inspection (when there is NO Inspector General).
- Cadet of the Semester & Six Weeks Boards.
- The appearance, discipline, efficiency, training and conduct of the Corps.
- Keeping the Corps Commander informed of all activities.
- Assisting the Corps Commander as needed.
- Compiling and maintaining a Continuity Binder for this position.
- Other duties as assigned.

**INSPECTOR GENERAL OF THE CORPS IS RESPONSIBLE FOR:**

- Officer in charge of preparing the unit for the annual Unit Inspection.
- Reports directly to the Corps Commander.
- Rumor Control.
- Keeping the instructors and Senior Staff informed of all observations.
- Compiling and maintaining a Continuity Binder for this position.

**DEPUTY COMMANDER OPERATIONS IS RESPONSIBLE FOR:**

- Direct supervision and training of Flight Commanders.
- Conduct periodic Flight Commander and Flight Sergeant training.
- The appearance, discipline, efficiency, training and conduct within the flights.
- Assisting the SASI and ASI as necessary. Ensure that all flight members have the opportunity to develop leadership commensurate with their individual abilities.
- The appearance, discipline, efficiency, training and conduct of the Corps.
- Keeping the Corps Commander & Vice Group Commander informed of all activities.
- Assisting the Corps Commander & Vice Group Commander as needed.
- Compiling and maintaining a Continuity Binder for this position.
- Other duties as assigned.

**DEPUTY COMMANDER OF TRAINING & TEAMS IS RESPONSIBLE FOR:**

- Supervising all Co-Curricular & Extra-Curricular Teams (see organizational chart).
- Monitoring the scheduling of team practices and competitions ensuring the activities are added to the Corps Schedule.

- The appearance, discipline, efficiency, training and conduct of the Corps.  
Keeping the Corps Commander, Vice Commander and Instructors advised on all Team Activities.
- Assisting the Corps Commander & Vice Group Commander as needed.
- Monitoring procedures, providing oversight and input, as requested, to insure the best use of material and personnel.
- Rumor control.
- Keeping instructors and Senior Staff informed of all observations.
- Compiling and maintaining a Continuity Binder for this position.
- Other duties assigned.

**DEPUTY COMMANDER SUPPORT IS RESPONSIBLE FOR:**

- Direct supervision of the Corps Staff.
- Review submitted After Action Reports within 48 hours (2 school days) of receipt.
- Identifying and establishing goals to be attained by the staff based on the Corps goals.
- Establishing committees -- assigning appropriate cadets, outlining committee duties, establishing committee suspense's (timelines) and monitoring committee progress at regular intervals, as directed by the Corps CC.
- The appearance, discipline, efficiency, training and conduct of the Corps Staff.
- Publishing of promotion orders and special orders.
- Keeping the Corps Commander & Vice Corps Commander informed of all activities.
- Assisting the Corps Commander & Vice Corps Commander as needed.
- Compiling and maintaining a Continuity Binder for this position.
- Other duties as assigned.

**SENIOR ENLISTED and/or OFFICER ADVISOR IS RESPONSIBLE FOR:**

- Reporting directly to the Corps Commander and performing assigned duties as directed.
- Representing the enlisted members of the TX-20063<sup>rd</sup>.
- Conducting Enlisted Advisory Council meetings once per 6 weeks and informing the Corps Commander of pertinent issues.
- Forming parades and other cadet formations as needed.
- Maintains all disciplinary action records.
- The appearance, discipline, efficiency, training and conduct of the Corps.
- Other duties as required.
- Compiling and maintaining a Continuity Binder for this position.

**FLIGHT COMMANDERS ARE RESPONSIBLE FOR:**

- Appearance, discipline, and military training of the flight under their command.
- The conduct of their flight and the conduct of all flight members during leadership training and in the academic classroom.
- Supervising their Flight Sergeant.  
Ensuring all assigned administrative suspense's for their flight are met.
- Leading and directing the cadet flight at all cadet formations.
- Advising the Deputy Commander Operations of discipline or other problems within the flight.
- Advising the Instructors on matter pertaining to their flight.

- Compiling and maintaining a Continuity Binder for this position.
- Other duties as assigned.

#### **FLIGHT SERGEANTS ARE RESPONSIBLE FOR:**

- Direct supervision of their Element Leaders.
- Forming up the flight for leadership training.
- Preparing the flight for personal/uniform inspection.
- Ensuring all assigned administrative tasks and reports for their Flight are completed accurately and in a timely manner for submission to the staff.
- Assisting the Flight Commander as required.
- Serving as acting Flight Commander as required.
- Maintaining the Flight Continuity Binder in the classroom.
- Assisting in the training of cadets.
- Other duties as assigned.

#### **ELEMENT LEADERS ARE RESPONSIBLE FOR:**

- Leading the element in the classroom and drill pad.
- Assisting the cadet Flight Commander and Flight Sergeant.
- Reporting to the Flight Sergeant the names of any cadets absent from the formation at the beginning of each class period.
- Other duties as assigned.

#### **FLIGHT GUIDE / GUIDON BEARER IS RESPONSIBLE FOR:**

- Leading the direction and rate of march for the flight.
- Using and storing the flight guide-on.
- Proficient in Guidon procedures IAW AFMAN 36-2203
- Other duties as assigned. **FLIGHT REPRESENTATIVES - STAFF DUTIES (Info, Awards & Decs, Logistics, etc.):**
  - Refer to the staff position they are designated to be aware of responsibilities within flight.
  - Other duties as assigned.

### **CORPS STAFF JOB DESCRIPTIONS**

#### **FINANCE OFFICER/NCOIC IS RESPONSIBLE FOR:**

- Reports to the Deputy Commander Support.
- Preparing the Corps' yearly budget and the monthly update of the budget.
- Assisting the Instructors and Corps Commander in planning, organizing, controlling, and coordinating unit fund raising drives.
- Keeping the Command Staff informed of all activities related to this position prior to staff meetings.
- Requesting funds for all events and purchases of equipment and supplies.
- Ensuring authorization for expenditures is incorporated into the staff meeting minutes.
- Preparing an annual After-Action report at the close of the year (due 1st week in May).
- Training at least one sophomore or junior cadet in the duties and responsibilities

- Monitors the Corps Fundraisers.
- Compiling and maintaining a Continuity Binder for this position.
- Other duties as assigned.

#### **LOGISTICS OFFICER/NCOIC IS RESPONSIBLE FOR:**

- Reports to the Deputy Commander Support.
- Assisting the ASI with receipt, issue and accounting of all items of uniform, equipment and supplies.
- Assisting the ASI in maintaining supply records.
- Training of at least one cadet in each flight on the proper procedures for filling out equipment hand receipts.
- Ensure the cleaning of AFJROTC facilities.
- Proper storage of uniforms, supplies, and equipment.
- Assisting the ASI with inventories.
- Keeping the Staff informed of all activities related to this position prior to staff meetings.
- Providing guidance to the cadet staff on proper supply discipline.
- Training at least one sophomore or junior cadet in the duties and responsibilities.
- Compiling and maintaining a Continuity Binder for this position.

#### **PUBLIC AFFAIRS & HISTORIAN OFFICER/NCOIC IS RESPONSIBLE FOR:**

- Reports to the Deputy Commander Support.
- Writing press stories and documenting Corps accomplishments and news
- Providing the ASI and SASI, through the chain of command, with information on all matter of publicity related to Tivy High School JROTC so it may be forwarded to AFJROTC Headquarters, as required.
- Coordinating with the Tivy Newspaper Staff in preparing publicity items concerning the Cadet Corps.
- Training of at least once cadet in each flight on proper procedures.
- Upon approval of the SASI, through the chain of command, ensuring appropriate publicity of Tivy High School AFJROTC is directed to each of the following important public segments:
  - The Cadet Corps.
  - The school population.
  - Tivy administration (Principal, Asst. Principals, Teachers and Staff).
  - KISD administration (Superintendent, School Board and KISD Staff).
  - Local news media-radio and TV.
  - The national public (United States Air Force, national magazines, and other AFJROTC units).
- Ensuring that all press releases are cleared by the SASI.
- Maintain the unit scrap book, history and other records, reflecting upon traditions, accomplishments and activities of the Cadet Corps. The unit scrapbook should be updated at the end of each semester.
- Training at least one junior or sophomore in your duties and responsibilities.
- Keeping the Corps Staff informed of activities prior to all staff meetings.
- Ensure space is reserved in the Tivy High School Yearbook for the Cadet Corps.
- Compiling and maintaining a Continuity Binder for this position.
- Rumor Control.



- Other duties as assigned.

#### **SCHEDULING OFFICER/NCOIC IS RESPONSIBLE FOR:**

- Reports to the Deputy Commander Support.
- Maintaining the Master Calendar of Events in the Instructor Office and in the classroom.
- Updating the TX-20063<sup>rd</sup> computerized calendar.
- Keeping the instructors, Command Staff, Corps Staff, Flights and organizations informed of possible scheduling conflicts both within the Corps and from outside organizations.
- Compiling and maintaining a Continuity Binder for this position.
- Other duties as assigned.
- Ensure space is reserved in the Tivy High School Yearbook for the Cadet Corps.
- Compiling and maintaining a Continuity Binder for this position.
- Rumor Control.
- Other duties as assigned.

#### **INFORMATION OFFICER/NCOIC IS RESPONSIBLE FOR:**

- Reports to the Deputy Commander Support.
- Working with the SASI and ASI to oversee the care of the unit administrative files.
- Keeping and posting minutes of cadet command staff meetings.
- Maintaining attendance records for cadet corps staff meeting and other meetings related to cadet Corps activities.
- Compiling and maintaining a Continuity Binder for this position.
- Rumor Control.
- Other duties as assigned.

#### **WEBMASTER / TECHNOLOGY OFFICER/NCOIC IS RESPONSIBLE FOR:**

- Reports to the Deputy Commander Support.
- The care, efficient use, and management of all cadet computer equipment.
- Maintaining a list of computer qualified cadets.
- Maintaining sign in/sign out sheets and rosters for accountability of all computer equipment.
- Assisting staff members in the production of computer generated products.
- **Entering data into the AFJROTC Wings data base.**
- As the Corps Photography Coordinator, responsible for training of photographers in the use of JROTC photographic equipment.
- Ensuring at least one, and no more than two, photographer(s) travel to all events such as: drill meets, football games, parades community service, and trips.
- Developing and maintaining the “unofficial” TX-20063 web page.
- Control access to and monitoring of webpages and social media • Compiling and maintaining a Continuity Binder for this position.
- Rumor Control.
- Other duties as assigned.

#### **AWARDS AND DECORATIONS OFFICER/NCOIC IS RESPONSIBLE FOR:**

- Reports to the Deputy Commander Support.
- Having a thorough understanding of Wings data base.
- Ensuring Flight Commanders prepare orders for their flights by the suspense dates.

- Ensuring award criteria is being met.
- Updating each cadet's awards and decorations file in CIMS.
- Assisting the Personnel Officer in maintaining Special Orders for Awards and Decs.
- Working with the Corps Commander Advisor (or other designated officer in charge) to plan and execute the annual Corps Award Ceremony.
- Other duties as assigned.

#### **MORALE WELFARE AND RECREATION OFFICER/NCOIC IS RESPONSIBLE FOR:**

- Reports to the Deputy Commander of Support  
Planning all Corps MWR events (e.g. Field Days, Christmas Dance, etc.) and assigns only officers and SNCOs as project officers.
- Reporting status of MWR events at Cadet Staff Meetings.
- Preparing an After Action Report (AAR) detailing events.
- Preparing suggested news releases for events and passing them to Public Affairs Officer/NCO for proper distribution.
- Compiling and Maintaining a Continuity Binder for this position.
- Rumor Control. • Other duties as assigned.

#### **LETTERMAN TRACKING OFFICER/NCOIC IS RESPONSIBLE FOR:**

- Reports to the Deputy Commander Support. • Tracking Letterman Points for all cadets in the Corps
  - Ensuring Flight CCs provide information on points earned for activities.
  - Periodically (at least every 2 weeks) post letterman jacket point totals.
- Ensuring letterman point criteria is being met.
- Notifies cadets who have qualified for an AFJROTC Letterman Jacket.
- Assists qualified cadets in completing application packet for a letterman jacket.
- Other duties as assigned.

### **CORPS TEAM COMMANDERS JOB DESCRIPTIONS**

#### **ARMED/UNARMED/COLOR GUARD TEAM CMDRS ARE RESPONSIBLE FOR:**

- Reporting directly to the Deputy Commander Training on all team related duties.
- Recruiting qualified team members.
- Issuing and ensuring the return of all team equipment from team members.
- Training their team in drill maneuvers.
- **Maintaining the Week In Review, listing all activities-date, time, location and participants.**
- Leading the teams in ceremonial functions.
- Commanding the teams in competitive drill meets.
- Coordinating teams for details/events or competitions.
- Maintaining a Continuity Binder for this position.
- Other duties as assigned.

#### **SABER TEAM – POW/MIA DETAIL COMMANDER:**

- Reporting directly to the Deputy Commander Training on all team related duties.

- Recruiting qualified team members.
- Issuing and ensuring the return of all team equipment from team members.  
Training their team in maneuvers.
- **Maintaining the Week In Review, listing all activities-date, time, location and participants.**
- Leading the teams in ceremonial functions.
- Commanding the teams in competitive meets.
- Coordinating teams for details/events or competitions.
- Maintaining a Continuity Binder for this position.
- Other duties as assigned.

#### **PERSONAL FITNESS (PT) TEAM COMMANDER:**

- Reporting directly to the Deputy Commander Training on all team related duties.
- Recruiting qualified team members.
- Establishing and overseeing a training program for all team members.
- **Maintaining the Week In Review, listing all activities-date, time, location and participants.**
- Commanding the teams in competitive meets.
- Coordinating teams for details/events or competitions.
- Maintaining a Continuity Binder for this position.
- Other duties as assigned.

#### **KITTY HAWK AIR SOCIETY COMMANDER IS RESPONSIBLE FOR:**

- Keeping Deputy Commander of Teams advised on all KHAS activities.
- Updating KHAS instructor mentor of KHAS activities and plans.
- Conducting annual search for qualified candidates.
- Conducting KHAS initiation.
- Overseeing KHAS community service projects.
- **Maintaining the Week In Review, listing all activities-date, time, location and participants.**
- Holding required periodic meetings.
- Assuring that all team members stay academically eligible.
- Overseeing any tutoring programs in AFJROTC.
- Maintaining a Continuity Binder for this position.
- Other duties as assigned.

#### **AWARENESS PRESENTATION TEAM CMDR/NCOICIS RESPONSIBLE FOR:**

- Reporting to the Deputy Commander of Training on all APT activities.
- Keeping the APT instructor mentor updated on all activities.
- Recruiting cadets to be members of the Awareness Presentation Team.
- Coordinating 5-10 minute speeches or skits for feeder schools.  
Designating 2-3 cadet teams to perform the presentations.
- **Maintaining the Week In Review, listing all activities-date, time, location and participants.**
- Setting goals for presentations.

- Preparing an annual After Action Report due no later than the first meeting in May.
- Training at least one junior or sophomore in your duties and responsibilities.
- Training all APT specialists on duties and responsibilities.
- Maintaining a log of all activities listing: date, time, location and participants.
- Compiling and maintaining a Continuity Binder for this position.
- Rumor Control.
- Other duties as assigned.

#### **MODEL ROCKETRY TEAM COMMANDER/NCOIC IS RESPONSIBLE FOR:**

- Reporting to the Deputy Commander of Training on all model rocketry activities.
- Keeping the Model Rocketry inspector mentor updated on all activities.
- Ensuring the team meets all the requirements as set forth in AFJROTC regulations.
- Training cadets in model rocketry procedures.
- Oversees Model Rocketry Badge Qualification training requirements.
- Requesting orders for equipment and material.
- Preparing an After Action Report at the close of the season.
- Training at least one sophomore or junior in the duties and responsibilities.
- Coordinating teams for details/events or competitions.
- **Maintaining the Week In Review, listing all activities-date, time, location and participants.**
- Compiling and maintaining a Continuity Binder for this position.
- Other Duties as assigned.

#### **QUADCOPTER DRONE FLIGHT TRAINING TEAM COMMANDER/NCOIC IS RESPONSIBLE FOR:**

- Reporting to the Deputy Commander of Training on all quadcopter activities.
- Keeping the quadcopter mentor updated on all activities.
- Ensuring the team meets all the requirements as set forth in AFJROTC regulations.
- Training cadets in quadcopter flight procedures.
- Requesting orders for equipment and material.
- Preparing an After Action Report at the close of the season.
- Training at least one sophomore or junior in the duties and responsibilities.
- Coordinating teams for details/events or competitions.
- **Maintaining the Week In Review, listing all activities-date, time, location and participants.**
- Compiling and maintaining a Continuity Binder for this position.
  - Rumor Control. Other Duties as assigned.

#### **Flag Running Team**

- Reporting to the Deputy Commander of Training on all flag running activities.
- Coordinating team for events.
- **Maintaining the Week In Review, listing all activities-date, time, location and participants.**
- Ensuring the team meets all the requirements as set forth in AFJROTC regulations.
- Compiling and maintaining a Continuity Binder for this position.

**CHAPTER 12*****UNIT MANNING DOCUMENT AND RANK AUTHORIZATIONS***

The rank to the left is the entry level rank, with the rank to the right being the highest rank in which a cadet may be promoted to. If a cadet is dual-enrolled, the higher year will apply. All deviations must be coordinated through the ASI and approved by the SASI.

<b>POSITION</b>	<b>TITLE</b>	<b>RANK</b>	<b>YEAR</b>	<b>AUTH</b>	
<b>COMMAND STAFF</b>	Corps (Squadron) Commander	c/Lt Col/Col	AS 3-4	1	
	Corps Commander Advisor	c/Lt Col/Col	AS 3-4	1	
	SASI/Corps Aid-de-Camp	c/Maj/Col	AS 3-4	1	
	Corps Vice Commander	c/Maj/Lt Col	AS 3-4	1	
	Corps Inspector General	c/Maj/Lt Col	AS 3-4	1	
	Deputy Commander Operations Operations Squadron Cmdr	c/Capt/Maj	AS 3-4	1	
	Deputy Commander Support Support Squadron Cmdr	c/Capt/Maj	AS 3-4	1	
	Deputy Commander Training Training Squadron Cmdr	c/Capt/Maj	AS 3-4	1	
	Chief Enlisted Advisor	c/CMSgt	AS 2-4	1	
<b>FLIGHT STAFF</b>	Flight Commander	c/2 <sup>nd</sup> Lt / Capt	AS 2-4	6	
	Flight Sergeant	c/TSgt / MSgt	AS 2-4	6	
	Flight Element Leaders	c/A1C / SSgt	AS 1-4	24	
	Flight Guide	c/A1C / TSgt	AS 1-4	6	
<b>CORPS STAFF</b>	Finance Officer	c/2 <sup>nd</sup> Lt / Capt	AS 2-4	1	
	Finance NCOIC	c/SSgt / MSgt	AS 1-4	1	
	Logistics Officer	c/2 <sup>nd</sup> Lt / Capt	AS 2-4	2	
	Logistics NCOIC	c/SSgt / MSgt	AS 1-4	1	
	PA/Historian Officer	c/2 <sup>nd</sup> Lt / Capt	AS 2-4	1	
	PA/Historian NCOIC	c/SSgt / MSgt	AS 1-4	1	
	Awards & Decs. Officer	c/2 <sup>nd</sup> Lt/Capt	AS 2-4	1	
	Awards & Decs. NCOIC	c/SSgt / MSgt	AS 1-4	1	
	Information Officer	c/2 <sup>nd</sup> Lt / Capt	AS 2-4	1	
	Information NCOIC	c/SSgt / MSgt	AS 1-4	1	
	Technology Officer	c/2 <sup>nd</sup> Lt / Capt	AS 2-4	1	
	Technology NCOIC	c/SSgt / MSgt	AS 1-4	1	
	Scheduling Officer	c/2 <sup>nd</sup> Lt / Capt	AS 2-4	1	
	Scheduling NCOIC	c/A1C / TSgt	AS 1-3	1	
MWR Officer	c/2 <sup>nd</sup> Lt / Capt	AS 2-4	1		

<b>COCURRICULAR TEAMS</b>	Color Guard Commander	c/2 <sup>nd</sup> Lt / Lt Col	AS 2-4	1
	Color Guard NCOIC	c/TSgt / SMSgt	AS 2-4	1
	Armed Drill Team Cmdr	c/2 <sup>nd</sup> Lt / Lt Col	AS 2-4	1
	Armed Drill Team NCOIC	c/TSgt / SMSgt	AS 2-4	1
	PT Team Commander	c/2 <sup>nd</sup> Lt / Lt Col	AS 2-4	1
	PT Team NCOIC	c/TSgt / SMSgt	AS 2-4	1
	KHAS Commander	c/1 <sup>st</sup> Lt / Maj	AS 2-4	1
	KHAS Vice Commander	c/2 <sup>nd</sup> Lt / Capt	AS 2-4	1
	APT Team Commander	c/2 <sup>nd</sup> Lt / Capt	AS 2-4	1
	Model Rocketry Team Commander	c/2 <sup>nd</sup> Lt / Capt	AS 2-4	1
	Model Rocketry Team NCOIC	c/TSgt / SMSgt	AS 2-4	1
	<b>Quadcopter Team Cmdr</b>	<b>c/2<sup>nd</sup> Lt / Capt</b>	<b>AS 2-4</b>	<b>1</b>
	<b>Quadcopter Team NCOIC</b>	<b>c/TSgt / SMSgt</b>	<b>AS 2-4</b>	<b>1</b>
	Saber-POW/MIA Commander	c/2 <sup>nd</sup> Lt / Capt	AS 2-4	1
	Saber-POW/MIA Asst Cmdr	c/2 <sup>nd</sup> Lt / 1 <sup>st</sup> Lt	AS 2-4	1
	Antler Tram NCOIC	c/SSgt / MSgt	AS 2-4	1
	Flag Runner Cmdr/NCOIC	c/SSgt / MSgt	AS 2-4	1
	Strat Gaming NCOIC	c/SSgt / MSgt	AS 2-4	1

Cadet Colonel	1%
Cadet Lieutenant Colonel	2%
Cadet Major	3%
Cadet Captain	5%
Cadet 1 <sup>st</sup> and 2 <sup>nd</sup> Lieutenant	No Limit
Cadet Chief Master Sergeant	1%
Cadet Senior Master Sergeant	3%
Cadet Master Sergeant	7%
Cadet Technical Sergeant	15%
Cadet Staff Sergeant	No Limit
Cadet Senior Airman	No Limit
Cadet Airman First Class	No Limit
Cadet Airman	No Limit

**The Tivy High School AFJROTC squadron strength, according to rank, cannot exceed the listed percentages. SNCO cadets are considered cadet MSgt through cadet CMSgt.**

## CHAPTER 13

### ***NATIONAL AND LOCAL AFJROTC AWARDS AND DECORATIONS***

1. A number of distinctive awards are authorized for AFJROTC Cadets to recognize outstanding academic and leadership performance or for a specific display of valor. Medals, ribbons, and certificates are awarded in the following categories:
  - **SPECIAL AWARDS:** Special awards are presented to cadets selected by the SASI and approved by the principal. These awards are authorized by AFJROTC publications. Cadets may only receive one National-level Award for each year they are in AFJROTC and may not receive the same National-level Award twice during their AFJROTC career (this does not apply to National competition awards). Cadets may refer to eligibility criteria upon request.
    1. **Gold Valor Award:** This award consists of a medal, ribbon, and certificate. The gold Valor Award recognizes the most outstanding voluntary acts of self-sacrifice and personal bravery by a cadet involving conspicuous risk of life above and beyond the call of duty.
    2. **Silver Valor Award:** Award consists of a medal, ribbon, and certificate. The Silver Valor Award is awarded to a cadet for a voluntary act of heroism which does not meet the risk-of-life requirements of the Gold Valor Award.
    3. **Cadet Humanitarian Award:** Award consists of a ribbon and certificate. It is intended to recognize cadets who provide aid in response to a singular extraordinary event such as a natural disaster or other catastrophe that has placed or has the potential to place a hardship on their fellow citizens. This award is not to be used to recognized day-to-day service in the community.
    4. **Silver Star Community Service with Excellence Award:** Awarded to the Top 5% of units (approx. 45 units) who have the highest “per cadet average” community service hours.
    5. **Community Service with Excellence Award:** Award consists of a ribbon and certificate. It is intended to recognized those individual cadets who provide significant leadership in the planning, organizing, directing, and executing of a major unit community service project that greatly benefit the local community. This is not an award given to participants but to the key leader(s) of the project.

**NATIONAL AWARDS:** National awards are presented to cadets selected by the SASI and approved by the principal. These awards are authorized by AFJROTC publications. Cadets may refer to eligibility criteria upon request. **Medals will not be worn on regular uniform days or during any type of competition.**

6. **Air Force Association Award:** This AFA-sponsored award consists of a medal and ribbon and is presented annually at each unit to the outstanding AS 3 cadet who possesses such characteristics as positive attitude, exceptional personal appearance, exemplary personal attributes, dependability, good character, courtesy demeanor, and a high degree of growth potential. The winner of this award must also rank in the upper 25% of the class in Aerospace Science, top 25% of their high school class for the current year, and achieve an overall academic standing in the upper 10% of his or her class.
7. **Daedalian Award:** This award consists of a medal and ribbon. It is presented to an AS 3 who has demonstrated an understanding and appreciation of patriotism, love of country, and service to the nation. They should possess the potential and desire to pursue a military career and must rank in the upper 10% of the junior class in the AFJROTC program and in the upper 20% of the class overall.
8. **Daughters of the American Revolution Award:** This award consists of a medal and ribbon. It is presented to an AS 4 cadet in the upper one-fourth of the graduating class and AS Class, who has demonstrated qualities of dependability, good character, military discipline, leadership ability, and a fundamental and patriotic understand of the importance of AFJROTC training.
9. **American Legion Scholastic Award:** This award consists of a medal and ribbon and is presented annually to an AS 3 or 4 cadet who is in the upper 10% of the high school class and in the upper 25% of the Aerospace Science Class. Cadet must demonstrate qualities of leadership, and actively participate in student activities, such as student organizations or athletics.
10. **American Legion General Military Excellence Award:** This award consists of a medal and ribbon and is presented annually to an AS 3 or 4 cadet who is in the upper 25% of the AS class, and who demonstrates outstanding qualities of military leadership, discipline, character, and citizenship.
11. **Reserve Officers Association (ROA) Award:** This award consists of a bronze medal, ribbon, and certificate. It is presented annually for military and academic achievement to an outstanding AS4 who possess characteristics of leadership, exceptional personal appearance, exemplary personal attributes, courtesy, growth potential, and rank in the top 10% of their AS class.



12. **Military Officers Association (MOA) Award:** This award consists of a medal pendant and ribbon. It is presented to an outstanding AS 3 cadet who shows exceptional potential for military leadership, high moral character, and high order of loyalty to the unit, school, and country.
13. **Veterans of Foreign Wars (VFW) Award:** This award consists of a medal pendant and ribbon. It is presented to an AS 3 or AS 4 cadet who is actively engaged in the AFJROTC program, possessing outstanding military bearing and conduct, strong positive personal attributes, demonstrates patriotism and leadership potential.
14. **National Society, United States Daughters of 1812 Award:** This award consists of a medal, ribbon and certificate. Is awarded at the SASI discretion for academic excellence, leadership, military discipline, dependability, patriotism and upright character in speech and habits.
15. **National Sojourners Award:** This award consists of a medal pendant, ribbon, and certificate. It is presented to an AS 2 or 3 cadets who contributed the most to encourage and demonstrate Americanism within the Corps of Cadets and on campus. The cadet must also be in the top 25% of his/her academic class, encourage and demonstrate the ideal of Americanism, and demonstrate potential for outstanding leadership.
16. **Scottish Rite, Southern Jurisdiction Award:** This award consists of a medal, ribbon, and certificate. It is presented to an AS 3 cadet who has contributed the most to encourage Americanism by participation in extracurricular activities or community projects, demonstrated academic excellence by being in the top 25% of their class, and demonstrated qualities of dependability, good character, self-discipline, good citizenship and patriotism.
17. **Military Order of the Purple Heart:** This award consists of a medal pendant and ribbon. It is presented to an outstanding AS 3 or 4 cadet who shows a positive attitude toward AFJROTC, demonstrates leadership ability, is active in school and community affairs, and attains a grade of “B” or better in all subjects.
18. **Sons of the American Revolution (SAR) Award:** This award consists of a bronze medal and ribbon. It is presented to an AS 3 cadet who exhibits a higher degree of leadership, military bearing, and all-around excellence in AS studies. The cadet must also be in the top 10% of their AFJROTC class and top 25% of their overall class.
19. **Military Order of the World Wars (MOWW) Award:** This award consists of a bronze medal pendant, certificate, and a ribbon. It is presented annually to a cadet who excels in all military and scholastic aspects and who has indicated, by military and scholastic grades, co- curricular LDR activities, and individual endeavors, a desire to serve our nation, and who has committed to continue in the AFJROTC program for the next year.

20. **American Veterans (AMVETS) Awards:** This award consists of a medal pendant and ribbon. It is presented annually to one qualified cadet that possesses a positive attitude towards Air Force JROTC programs and service in the Air Force. The cadet must obtain a grade of “A” in Aerospace Science, be a JROTC potential officer candidate and be in good standing in all scholastic grades at time of selection.
21. **Air Force Sergeants Association (AFSA) Award:** This award consists of a medal pendant and ribbon. It is presented to an AS 3 or 4 cadet who demonstrates outstanding qualities in military leadership, discipline, character, and citizenship. The cadet must also be in the 25% of the AFJROTC class.
22. **Tuskegee Airman Incorporated (TAI) AFJROTC Award:** This award consists of a ribbon and certificate. It is presented to two AS 1 or 2 cadets who are in good academic standing, having actively participated in cadet corps activities, and demonstrated a potential for leadership.
23. **The Retired Enlisted Association (TREA) Award:** This award consists of a medal set, ribbon, and certificated. It is presented to an enlisted cadet who shows exceptional leadership throughout the course of the school year.
24. **Celebrate Freedom Foundation Award:** This award consists of a ribbon and certificate and is presented annually to an outstanding AS1 or AS2 cadet. The cadet must have: a positive attitude toward JROTC and school, outstanding personal appearance, courteous demeanor, growth potential, indicated potential and desire to pursue a military career. The cadet must also display personal attributes such as initiative, judgment, and self-confidence.
25. **Air Commando Association Award:** Consists of a medal, ribbon and certificate. Awarded annually at the SASI’s discretion to a cadet who emulates the 13 critical attributes of the AF Special Operations Mission: integrity, self-motivation, intelligence, self-discipline, perseverance, adaptability, maturity, judgment, selflessness, leadership, skilled, physical fitness and family strength.
- **AIR FORCE JUNIOR ROTC UNIT, CADET, and TEAM (LDR) AWARDS:**

26. **Distinguished Unit Award with Merit (DUAM):** Awarded to cadets who are enrolled during same academic year in which 1) the unit receives a HQ AFJROTC evaluation with an overall rating of Exceeds Standards and 2) the unit is selected by HQ AFJROTC to receive the DUA. Both criteria must be met in the same academic year.

27. **Distinguished Unit Award (DUA):** This ribbon is awarded to cadets who are enrolled during the academic year when a unit is selected by HQ AFJROTC to receive DUA.
28. **Outstanding Organization Award (OOA):** Awarded to cadets enrolled during the academic year when a unit is selected by HQ AFJROTC to receive the OOA.
29. **Outstanding Flight Ribbon:** This ribbon is awarded to members of the top flight in the flight competition **each semester**. The award of a cluster will recognize each subsequent award.
30. **Top Performer Award:** This Outstanding Cadet Ribbon (OCR) is a Headquarters AFJROTC award presented to a maximum of 2% of the cadet corps. The award of a cluster will recognize each subsequent award. Cadets chosen as State, Pacific and European “AFJROTC and AFA Cadet Leadership Award” winners will be awarded the OCR with silver star.
31. **Outstanding Cadet Ribbon:** This ribbon is awarded annually to the outstanding first-year, second-year, third-year, and fourth-year cadet. The cadet must demonstrate, high moral character, positive personal attributes, display outstanding military potential, and attain academic and military excellence. The award of a cluster will recognize each subsequent award.
32. **Leadership Ribbon:** This ribbon is awarded annually to not more than 5% of the cadets who have displayed outstanding leadership ability above and beyond the performance normally expected. The award of a cluster will recognize each subsequent award.
33. **Superior Performance Ribbon:** This ribbon is awarded annually to not more than 10% of the cadets for recognition of achievements and services which are clearly outstanding and unmistakably exceptional when compared to similar achievements and accomplishments of other cadets. The award of a cluster will recognize each subsequent award.
34. **Achievement Ribbon:** This ribbon is awarded annually to not more than 5% of the cadets who display significant achievement as deemed appropriate in the judgment of the SASI. The award of a cluster will recognize each subsequent award.
35. **Academic Ribbon:** This ribbon is awarded for academic excellence as signified by attaining an overall grade point average of at least “B” with an “A” average in AFJROTC. The award of a cluster will recognize each subsequent award.
36. **Cadet Leadership Course (CLC) Ribbon:** This ribbon is awarded for the completion of an approved AFJROTC Summer Leadership Program of at least 5 days in duration. For each additional leadership school completion,

a bronze star will be awarded. A silver star will be awarded for outstanding performance or leadership ability at a leadership school instead of a bronze star.

37. **Special Teams Placement Ribbon:** This ribbon is awarded to team members for placing first, second or third in an Air Force or Joint Service competition (local, regional, state or national level) to include: Color Guard Teams, Rifle Teams, Drill Teams, Saber Teams, Academic Bowl Teams, Cyber Patriot, etc.).
38. **All Service National Competition Ribbon:** Awarded to team members who compete at a national level competition.
39. **Air Force National Competition Ribbon:** Awarded to team members who compete at an Air Force JROTC national level competition.
40. **Orienteering Competition Ribbon:** Is awarded to team members for completing a unit specific Orienteering Program as a part of the unit curriculum.
41. **Leadership Development Requirement (LDR) Leadership Ribbon:** This ribbon is awarded to cadets who demonstrate exception leadership attributes in achieving objectives through coordinated efforts of others in AFJROTC LDR activities (such as chairperson of the Military Ball, Field Day, Christmas Dance, Awards Ceremony, etc.). The award of a cluster will recognize each subsequent award and may be earned a maximum of 4 times.
42. **Drill Team Ribbon:** This ribbon is awarded to cadets who participate in at least 80% of all drill team practices and participate in at least 2 team competitions per academic year. The award of a cluster will recognize each subsequent award.
43. **Color Guard Ribbon:** This ribbon is awarded to cadets who attend 80% of all color guard practices and participate in at least 2 team events per academic year. The award of a cluster will recognize each subsequent award.
44. **Saber Team Ribbon:** This ribbon is awarded to cadets who participate in 2 saber team details per academic year. The award of a cluster will recognize each subsequent award.
45. **Marksmanship Ribbon:** Ribbon is awarded annually to cadets who participate in the unit's competitive marksmanship team. (Marksmanship is NOT currently offered by the TX-20063<sup>rd</sup>).
46. **Good Conduct Ribbon:** This ribbon is awarded to cadets with no referrals (ISS/OSS) for the academic term, suspensions of any kind, no adverse

reports from other staff or faculty in an academic semester. The award of a cluster will recognize each subsequent award.

47. **Service Ribbon:** This ribbon is awarded at the SASI's discretion for distinctive performance in school, community, or AFJROTC service projects to cadets whose active participation contributed significantly to the overall objective and goals of the organization. Cadets earn this ribbon by completing 8 hours of community service in AFJROTC. The award of a cluster will recognize each subsequent award (each additional 8 hours).
48. **Health and Wellness Ribbon:** This ribbon is awarded to cadets that participate in the health and wellness physical fitness program. All cadets who participate in the program will receive the Health and Wellness Ribbon. Cadets who participate in the Presidential Physical Fitness Program and score in the 75-84 percentiles will receive a second Health and Wellness Ribbon and wear a Bronze Star. If they score within the 85-95% they will receive a Silver Star, and a 96 – 100% will receive a Gold Star for the second ribbon.
49. **Recruiting Ribbon:** This ribbon is awarded to cadets for outstanding efforts in support of unit recruiting activities, in addition to recruiting at least one cadet into AFJROTC. The award of a cluster will recognize each subsequent award.
50. **Activities Ribbon:** This ribbon is awarded to cadets who have participated in co-curricular activities other than Drill, Color Guard, and Saber teams. These include, but are not limited to orienteering teams, model rocketry clubs, AFJROTC Academic Teams and AFJROTC sports teams. The award of a cluster will recognize each subsequent year of the award.
51. **Attendance Ribbon:** This ribbon is awarded to cadets with no more than 3 school absences in an academic term. absences and no unexcused absences in an **academic semester**. The award of a cluster will recognize each subsequent award.
52. **Dress and Appearance Ribbon:** This ribbon is awarded to cadets who wear the JROTC, uniform on all designated uniform days and conforming to all AFJROTC dress and appearance standards and maintaining a 90% or above with no "0". It will be awarded at the end of the 5<sup>th</sup> six weeks.
53. **Longevity Ribbon:** This ribbon is awarded to cadets for successful completion of each AS year or second semester if they were not enrolled the first semester. Cadets may receive one award annually.
54. **Bataan Death March Memorial Hike Ribbon:** AFJROTC units may conduct an optional 14 mile Bataan Death March Memorial Hike to honor and remember the sacrifices of the victims and survivors of World War II's

Bataan Death March. Event must be accomplished on a locally determined 14 mile course over a span of no more than three days.

**55. Patriotic Flag Ribbon:** May be awarded for participation in non-color guard events specifically designed to honor our nation's flag. Such events include flag raising ceremonies, flag folding ceremonies, flag retirement ceremonies, and historical flag demonstrations. Members of the Corps who participate in the flag folding ceremony on Veterans Day qualify for this ribbon.

- **CIVIL AIR PATROL (CAP) AUTHORIZED AWARDS EARNED IN CAP:**

**56. General Carl Spaatz Award (CAP Award)**

**57. General Ira C. Eaker Award (CAP)**

**58. Amelia Earhart Award (CAP)**

**59. Gen Billy Mitchell Award (CAP)**

**60. Gen J. F. Curry Award (CAP)**

- **OTHER NATIONAL AWARDS.** These medals and ribbons **CANNOT** be worn in the AFJROTC uniform if earned after 1 Aug 2018. They **CANNOT** be presented during the Annual Awards Ceremony. If earned prior to 30 July 2018, during regular uniform days the following award ribbons can be worn in the following precedence listed below following the Patriotic Flag Ribbon.

**1. Sons of Union Veterans of the Civil War (SUVCW) Award:** This award consists of a medal pendant and ribbon. It is presented to one deserving cadet annually (may be first, second, third, or fourth year cadet), who displays a high degree of patriotism and has demonstrated a high degree of academic excellence and leadership ability.

**2. Sons of Confederate Veteran's H.L. Hunley Award:** This award consists of a medal, ribbon and certificate. This award should go to a rising second year cadet who has demonstrated the qualities of Honor, Courage and in particular Commitment to his/her unit throughout the school year.

**3. Robert E. Lee Leadership Award:** Consists of a medal, ribbon and certificate. Awarded annually at the SASI's discretion to a cadet who emulates leadership, moral character, and dedication to duty that was so superbly personified by General Robert E. Lee.

**4. Any non-funded National Awards (i.e. NCOA, National Society, Daughters of Founders and Patriots of America, American Military Retirees Association**

“LEAP,” United Daughters of the Confederacy, etc.)

### **Medals:**

**Medals will not be worn on regular uniform days or during any type of competition.** Medals may be worn on the semi-formal uniform only for formal and semi-formal occasions of a limited nature including dining ins/outs, and military ball or other formal events as prescribed by the SASI. Medals and ribbons cannot be worn together.

### **Scholarships:**

The Tivy Class of 1952 gifted the Corps with \$1,100 that will be given as scholarships. There will be one \$500 and two \$300 Awards for cadets who meet the following requirements: Be in the top 25 percent of his or her class in AFJROTC and have demonstrated outstanding qualities in military leadership, discipline, character, and citizenship.

Brigadier General William C. ‘Sonny’ Lindley Memorial Scholarship for \$1,500.00. Senior cadets may write a research paper on Gen Lindley and submit an application for consideration for this scholarship. The Lindley family makes the determination on the winner.

- **BADGES**

- **Distinguished AFJROTC Cadet Award:** This award consists of a certificate and a Distinguished AFJROTC Cadet Badge. This award recognizes one outstanding AS 3 cadet annually at each unit. Selection is made at the end of each school year. This allows the recipient to wear the award throughout the senior year. The recipient must be of high moral character, demonstrate positive personal attributes, display outstanding military potential, and maintain consistent academic and military excellence.
- **Ground School Badge:** Awarded for completion of the AFJROTC aviation honors ground school curriculum or successful completion of another aviation ground school program prescribed by the FAA. Instructors will Email [HQ-Logistics@afjrotc.com](mailto:HQ-Logistics@afjrotc.com) a copy of the cadet’s Ground School Certificate, and then go to WINGS \ Logistics \ Create Display Orders. Flight suits are authorized for those cadets currently enrolled in or that have successfully completed aviation honors ground school, been awarded a flight solo badge, flight certificate badge or have successfully completed the AFJROTC Flight Academy program.
- **Flight Solo Badge:** Awarded to any cadet possessing a solo flight certificate signed by a FAA certified flight instructor for either powered or non-powered aircraft.
- **Pilot Certificate Badge:** Awarded to any cadet who possesses a valid FAA pilot’s certificate for either powered or non-powered aircraft.
- **Model Rocketry Badge:** This badge is awarded to members of the Model Rocketry Club who have successfully completed all of the club objectives.

- **Awareness Presentation Team Badge:** This badge is awarded to cadets who have given a minimum of three presentations to a local civic organization or elementary and intermediate schools.
- **Kitty Hawk Air Society Badge:** This badge is awarded to members of the Kitty Hawk Air Society who meet the required academic GPA of 85 on a 100 point scale with a 90 or above in AFJROTC.
- **Aerospace Education Foundation (AEF) Academic Cadet Badge:** Awarded to rising Junior and Senior cadets for academic excellence as signified by attaining an overall 3.3 grade point average with no grade below “C” on their transcript. The individuals must be recommended by the SASI.
- **Cadet of the 6 Weeks.** Cadets will be nominated through the chain of Command for Cadet of the 6 weeks based on their performance in and out of the class room. The cadets will meet a board to determine the Cadet of the Semester.
  - b. The cadet board will consist of members of the Command Staff.
  - c. Cadets will be rated in the areas of uniform appearance and basic cadet knowledge in chain of command and ranks. The chairperson of the board must inform cadets and allow ample time to prepare for the board.
  - d. After the board has convened and determined the cadet of the 6 weeks for each of the categories, a memo must be written and turned into the Instructors for approval. Results will be entered into the Cadet’s personnel file.
  - e. Recognition will be announced within three school days of the board. Winning cadets will receive their award in their flights and be recognized during the Annual Awards Ceremony.
- **Cadet of the Year.** Cadets of the 6 Weeks from each category will compete for Cadet of the Year. The cadets will meet a board to determine the Cadet of the Year.
  - a. The board will consist of members of the Command Staff
  - b. The cadets will be rated in the areas of uniform appearance and basic cadet knowledge in the chain of command and ranks. The chairperson of the board must inform the cadets and allow ample time to prepare for the board.
  - c. After the board has convened and determined the cadet of the Semester for each of the categories, a memo must be written and turned into the Instructors for approval. Results will be entered into the Cadet’s personnel file.



- d. Recognition will be announced within three school days of the board. Winning cadets will receive their award in their flights and recognized during the Annual Awards Ceremony.

## CHAPTER 14

### ***CERTIFICATES OF COMPLETION AND TRAINING***

1. There are two types of certificates that may be awarded to AFJROTC cadets. They are the **Certificate of Completion** and the **Certificate of Training**. Descriptions of each follow.
  - a. **Certificate of Completion.** Presented to cadets in good standing who have satisfactorily completed three or more years of JROTC. Cadets must have this certificate in their possession when joining the senior ROTC program or upon enlisting in the Armed Forces will gain advanced rank benefits offered by the respective branch of service.
    - With the **Certificate of Completion**, the cadet will be excused from one year of the General Military Course (GMC) of the senior AFROTC program. This privilege must be arranged with the Professor of Aerospace Science (PAS) at the time of enrollment in the college or university.
    - If the cadet elects to enlist in one of the branches of the Armed Forces, the **Certificate of Completion** will provide for promotion to pay grade of E-3 in most cases, by all branches of the service except the USMC (promotes to E-2). This promotion at the time of enlistment provides for an immediate monetary benefit. It also makes the cadet senior to personnel without such a certificate who enlist at the same time, and theoretically makes the cadet eligible for earlier future promotions.
  - b. **Certificate of Training.** This certificate is presented to cadets in good standing who satisfactorily complete two or more years of a JROTC program.
    - With the certificate of training, a cadet may be excused from one academic term (semester or quarter) of the GMC of the senior AFROTC program. This privilege, again, must be arranged with the PAS at the time of college or university enrollment.
    - If the cadet elects to enlist in one of the branches of the Armed Forces, the **Certificate of Training** will provide for promotion to pay grade of E-2 by all branches of the service providing and immediate monetary benefit.
2. “Satisfactorily completed”, means both a passing numerical grade for the year and a letter grade higher than “Unsatisfactory” (either “N,” “S,” or “E”) in citizenship; otherwise, a student has not satisfactorily completed the course. The SASI is the final decision authority on these Certificates of Completion and Training.

## CHAPTER 15

### ***7 YEAR CURRICULUM PLAN & COURSE OFFERINGS***

The AFJROTC program is grounded in the Air Force Corps Values of – Integrity First, Service Before Self, and Excellence in All We Do. The Curriculum emphasizes the Air Force heritage and traditions, the development of flight sciences, military aerospace policies, and space exploration.

The AFJROTC curriculum is 40% Aerospace Science, 40% Leadership Education and 20% Wellness. Students in the program are identified as Aerospace Science 1 or AS1 (first year), AS 2 (second year), AS 3 (third year), AS 4 (fourth year) cadets. The first three years concentrate on aerospace science, leadership skills, and drill. The fourth year concentrates on research and planning for higher education and future careers. In addition, cadets in the Corps Staff have as their primary task to improve their life skills by managing and directing Corps activities. Further, they assist the Aerospace Science Instructor (ASI) and Senior Aerospace Science Instructor (SASI) in the management of Corps operations, development of unit goals, and the means to accomplish them. Wellness Education is included in every year of the curriculum.

#### **1. Air Force Junior ROTC Courses Offered at Tivy High School (\*\* indicates what will be taught in SY2021/22)**

##### **Aerospace Science**

- \*\* AS-100: A Journey into Aviation History
- AS-200: The Science of Flight: A Gateway to New Horizons
- AS-300: Exploring Space: The High Frontier
- AS-400: Management of the Cadet Corps

##### **Leadership Education**

- \*\* LE-100: Traditions, Wellness, and Foundations of Citizenship
- LE-200: Communication, Awareness, and Leadership
- LE-300: Life Skills and Career Opportunities
- LE-400: Principles of Management

##### **Wellness**

- \*\* **Cadet Health and Wellness Program**

**The 7-Year Curriculum Plan** for Tivy’s Air Force Junior ROTC with Course Offerings is published online under the **Tivy High School webpage / Activities / AFJROTC**.

A syllabus for each course will be issued to each cadet at the beginning of each school year.

## CHAPTER 16

### ***ADMISSION, TRANSFER, AND DISENROLLMENT OF CADETS***

1. **ADMISSION:** to be eligible for membership in the AFJROTC program, each cadet must be:
  - An American citizen or an alien admitted for permanent residence.
  - Physically capable of participating in AFJROTC physical training.
  - Enrolled and attending a regular course of instruction at Tivy High School. (Can be waived in accordance with KISD policy and AFJROTC policy).
  - Selected by the SASI in coordination with the Principal or designated representative.
  - Each cadet must comply with the rules and regulations of the Aerospace Science Department.
  - Must accept responsibility for care and maintenance of the Air Force uniform, textbooks, and other U.S. Government property.
  
2. **TRANSFER:** Transfer students from Army, Navy, Marines, Coast Guard or other AFJROTC units will be admitted with full credit for JROTC training already received, to include documented awards and decorations. Cadet rank for transfer students will be determined in accordance with AFJROTC policy, TX-20063<sup>rd</sup> Cadet Guide, and instructor determination.
  
3. **DISENROLLMENT:** A cadet may be dis-enrolled for any of the following reasons:
  - Failure to wear the uniform on designated days. TX-20063 has a three strikes and your out policy.
  - Failure to maintain acceptable cadet standards including, but not limited to, unacceptable conduct both on and off campus, improper attitude, failure to meet grooming standards, not meeting established standards prescribed by the cadet guide, and or honor code violations.
  - Inaptitude or indifference to training.
  - Serious violation of KISD Student Handbook.
  - Any violation as specified in Chapter D – Discipline.
  - Failing AFJROTC academics, leadership labs, or leadership training any one semester or term.
  - Any other reason deemed appropriate by the SASI or Tivy High Principal. For example, failure to wear the uniform as required is grounds for disenrollment.
  - The SASI is the final disenrollment authority for all AFJROTC cadets.

**IMPORTANT NOTE:** The AFJROTC program is a strictly voluntary program. Failure of students to maintain the standards outlined in this guide will result in removal from the program.

## CHAPTER D

### Discipline

Throughout this guide, cadet expectations and standards have been clearly presented. This chapter outlines TX-20063 process for maintaining discipline within the Corps of Cadets.

Discipline is the foundation of a successful military organization and a key ingredient to have a successful life. The ability to observe, evaluate, and make the right decisions for yourself are vital to success (in the military, in business, in professional and personal life.) Discipline should NOT be thought of solely in a negative context.

In its natural sense, discipline is systematic instruction intended to train a person, sometimes literally called a disciple, in a craft, trade or other activity, or to follow a particular code of conduct or "order". Often, the phrase "to discipline" carries a negative connotation. This is because enforcement of order—that is, ensuring instructions are carried out—is often regulated through punishment.

Discipline is the assertion of willpower over more base desires, and is usually understood to be synonymous with self-control. Self-discipline is to some extent a substitute for motivation, when one uses reason to determine the best course of action that opposes one's desires.

Virtuous behavior is when one's motivations are aligned with one's reasoned aims: to do what one knows is best and to do it gladly. Continent behavior, on the other hand, is when one does what one knows is best, but must do it by opposing one's motivations. Moving from continent to virtuous behavior requires training and some self-discipline.

from  
Wikipedia.org

Cadets are expected to be able to determine “right” from “wrong” actions at all times. We are guided by the cadet honor code of:

**“I will not lie, cheat, or steal nor tolerate those who do.”**

These simple words are the basis for a code to live by for the remainder of a cadet’s life. However, these words are specific and clear in their demands and are still relevant in our society. A cadet should be HONEST in both words and deeds. A cadet should not make quibbling and evasive statements, should do their own work, and should assist others to cooperate to meet

common goals. Trustworthiness not just in battle but throughout life is not only noble but necessary for the welfare and continued existence of our civilized society. The code requires self-control and a conscious effort to not take the easy road for short-term success, but to take the hard road for long-term success. Eventually living by the code will become an ingrained habit of the cadet's total lifestyle. The Honor Code stresses that lying, cheating, or stealing is not tolerated and that HONOR is a noble, moral standard that is the essence of our Corps and our civilized society.

### **PERSONAL STANDARDS OF CONDUCT:**

- Cadets become a leader by exhibiting positive character qualities of Integrity, Service, Excellence, intelligence, good judgment, decisiveness, and initiative. Cadets inspire others to follow by setting examples of truthfulness, confidence, and maturity. In order to realize the cadet's highest potential, cadets must maintain high standards of self-discipline, high ideals, good manners, social grace, appropriate dress (in or out of uniform), using appropriate language in and out of uniform (no profanity), and proper grooming.
- Cadets will display friendliness and respect to other students, Tivy High School faculty, Aerospace Science Instructors and other AFJROTC cadets. You will greet other cadets and Aerospace Science Instructors in a pleasant manner, regardless of location.
- Cadet officers will exercise discretion in enforcing military courtesy. Cadets will not be placed in an embarrassing situation by a public reprimand. However, cadet officers have the authority and the responsibility to deal with violations of military customs or courtesies.
- Cadets will show respect for Aerospace Science Instructors and any guest speakers by addressing them as 'sir" or "ma'am" and by responding to them in the same manner.
- Enlisted cadets show their respect for cadet officers by addressing and responding to them as "sir" or "ma'am."
- Cadets will not wear hats (uniform or civilian) indoors unless permission is obtained from the SASI. When cadets are in uniform and carrying weapons they will wear the correct headgear outdoors and indoors.
- Cadets will show proper respect to the Flag of the United States at all times, both inside and outside of buildings. This respect includes following the procedures contained in this guide.
- Cadets will follow procedures outlined in this cadet guide and will obey reasonable orders from all senior cadets, regardless of position or rank.

**UNACCEPTABLE BEHAVIOR:** Cadets who knowingly violate the AFJROTC standards of

conduct and performance are subject to the following disciplinary process. If a cadet engages in unacceptable behavior, AFJROTC reserves the right to impose disciplinary actions in addition to any consequences a cadet might receive from other THS teachers and/or administrators.

- Cadet Officers and Noncommissioned Officers are responsible for maintaining discipline and setting a good example at all times.
  - Cadets will NOT attempt to use AFJROTC rank or position to obtain personal gain or favor.
  - They will never demean, belittle, harass or use obscene language.
- Any abuse of cadet officer or cadet NCO authority may result in immediate removal from a position of command, authority, and supervision by and instructor and possible subsequent demotion.

**Consequences:** The consequences for not following the standard of conduct are subject to written counseling, a Demerit System or in most grievous instances a Corps Disciplinary board. Cadets are expected to accept the consequences for their actions should they forget or willfully break a rule.

### Written Counseling

**Letter of Counseling:** A Letter of Counseling may be issued for the following repeated (two times or more of a specific) infractions of TX-20063 Standards of Conduct. The cadet's flight sergeant or flight commander (or higher cadet staff position) will issue a Letter of Counseling. A Letter of Counseling will remain in a cadet's records for at least one month at which time it may be removed if deemed appropriate by the cadet's supervisor, for repeated infractions, i.e. two or more.

1. Unprepared for class
  2. Disrupting class
  3. Sleeping in class
  4. Talking without permission
  5. Sitting on tables
  6. Wearing a hat in class
  7. Violating handbook guidelines
  8. Hair or sideburns not in compliance
  9. Unauthorized jewelry
  10. Violation of dress code
- All disciplinary actions are routed to the SEA, who sends them up the chain of command. The SEA maintains all disciplinary records.

### Demerit Procedures

**OBJECTIVE:** The point of a demerit is to help train (discipline) a cadet to have better character and succeed as a leader!

SEA will have responsibility of disciplinary actions if SEA is a position not filled then Vice Corps will assume all disciplinary duties.

Author of Demerits: Corps Commander, Vice Corps Commander, Inspector General, Deputy Commander, Corps Commander Advisor, Special Assistant to the Senior Instructor and the Senior Enlisted Advisor (for enlisted cadets only) and the instructors.

Reasons:

- Conduct unbecoming a cadet
  - Failure to perform duties
  - Failure to wear the uniform
  - Lack of military courtesy
  - Abuse of officer or NCO authority
  - Missing scheduled meeting
  - Failure to turn in staff work
  - Writing on instructional boards without permission
  - Horseplay in class
  - Making improper or inappropriate gestures
- **1st demerit** = “Loss of Good Standing” for one week. (If a large event is happening that one week like military ball that will be up to the instructor)
  - **2nd demerit** = Detention which shall be constructive to AFJROTC (Work that isn’t done initially)
  - **3rd demerit** = Meeting with the disciplinary board and no possible promotions.
  - **4th demerit** = No promotions and loss of position/authority (i.e. cadet rank)

Demerits will remain in the cadet’s records minimum of 18 weeks (one full semester). After 18 weeks the demerit may be removed based on the flight commander’s recommendation and a Deputy Commander, or above, approval.

**Steps:**

1. Author of the demerit must sign two copies
  2. Author will bring the demerit with proper evidence to the Corps Commander. CC will then sign both copies if deemed appropriate / true. If Corps Commander is the author, then both instructors with review and sign.
  3. Corps Commander then brings both copies with evidence to an instructor for review and signature.
  4. If demerit is reviewed properly and signed by all parties then it will be passed on to the receiver of demerit.
  5. While the demerit is being served there will be the author, corps commander and vice corps commander in room with the receiver. If author is the Corps Commander or Vice Corps Commander then a Deputy Commander will step into role of witness.
  6. Receiver will be counseled on the issue and sign saying they were counseled correctly and understand the consequences. \*by signing this document they are saying they have received and understand the action being taken for such issue.\*
- Author will explain the

issue and how to fix this issue. The council/ board will allow the intended to explain themselves. There will NOT be any

bashing/slandering of receiver (we are all cadets, so treat others how you wish to be treated!)

ALL information will be documented and put into record in the under disciplinary tab of SEA continuity binder.

### **CADET CORPS DISCIPLINARY BOARD**

- Board members - Corps Commander, Vice Corps Commander, Deputy Commanders, Corps Commander Advisor, Special Assistant to the Senior Instructor, and the Senior Enlisted Advisor.
- All Disciplinary Boards will be monitored by an instructor.
- Disciplinary Board Actions.

#### **Infractions That Could Be Referred To The Board:**

Discipline may consist of, but is not limited to, loss of standing, temporary reduction in rank, temporarily withholding promotion, removal from position, and permanent reduction in rank

1. Cadet Honor Code violation
2. Insubordination or disobedience
3. Unexcused missed formation such as parade, color guard or drill team performance, etc.
4. Multiple Letters of Counseling
5. Disrespect to cadet officer or cadet placed in position of authority
6. Misuse of property
7. Profanity
8. Failure to perform assigned duty or duties

#### **Behaviors That Require a Cadet Review Board:**

This could result in actions up to a recommendation to the SASI for dismissal from the program.

1. Cadet Honor Code Violation (to include: Lying, Stealing, Cheating)
2. Vandalism
3. Alcohol or Drug related
4. Weapons violation
5. Fighting
6. Disrespect to teachers or staff
7. Suspension for any reason
8. Any infractions involving Law Enforcement either ON/OFF school property
9. Any other official reasons not listed

- All Disciplinary Board decisions will be reviewed by the ASI for compliance with this guidance and presented to the SASI for final approval / decision.



**Exception:** Sometimes for the good of the program an individual may be removed immediately from a position and/or reduced in rank when agreed upon by the SASI.

- All disciplinary actions are routed to the SEA, who sends them up the chain of command. The SEA maintains all disciplinary records.

## **NON-NEGOTIABLE ITEMS REQUIRING INSTRUCTOR ACTION**

### **Zero-Tolerance Items: Hazing and Harassment**

**HAZING:** Hazing, degrading, or deliberately embarrassing cadets will NOT be tolerated or permitted during any AFJROTC event or activity in or out of the classroom, this includes OFF CAMPUS as well. The TX-20063<sup>rd</sup> instructors will continually review unit policies to ensure the health and wellbeing of all cadets is maintained so no cadet is placed at risk. Cadets in leadership positions are continually trained to recognize hazing and inappropriate disciplinary activity. Cadet leaders set the example for other cadets in the Corps. In accordance with AFJROTC policy; push-ups or any other type of physical discipline is not condoned. This behavior will be immediately reported to the chain of command. The ASI and SASI will also be informed immediately. If the effected cadet feels it is necessary, he/she may report the incident directly to the ASI or SASI. Physical discipline such as doing push-ups for an infraction is considered hazing and will not be done.

### **HARASSMENT: NO FORM OF SEXUAL HARASSMENT WILL BE TOLERATED!**

Any of the following may constitute sexual harassment or discrimination: • Physical Contact:

Squeezing a person's shoulder or putting a hand around their waist.

- Gestures: Puckering one's lip suggestively or making obscene signs with one's fingers or hands.
- Jokes: Telling off-color, ethnic, or racial jokes
- Pictures: Pin-ups, particularly those of scantily clad individuals
- Comments: Generalities that lump certain groups together or denigrate them.
- Terms of Endearment: Calling anyone "honey," "dear," "sweetheart," or similar expressions are unacceptable. The effect is the primary issue rather than the intent. Even if you have "used the term for years," these expressions are inappropriate.
- Questionable Compliments: Compliments can make individuals feel uncomfortable or worse. Even if the person who received the "compliment" is not disturbed by it, others may be. Questions regarding this chapter should be addressed to the SASI.

**SOCIAL MEDIA CONTRACT:** The Tivy High School cadets are expected to behave by the following social media guidelines:

- No showing pictures or discussing in any way: drinking alcohol, using tobacco, or other ILLEGAL items or behavior.
- No sending of inappropriate pictures of oneself or others to other students or minors.
- No showing pictures or discussing in any way: sexual promiscuity (this includes inappropriate PDA with the same and opposite gender).
- No acting in a way or showing pictures of or discussing behavior that tarnishes the Kerrville ISD, the Air Force, or the TX-20063<sup>rd</sup> reputation.
- No activity of any kind that qualifies as bullying or harassment.
- No other activities that go against the KISD handbook or code of conduct.

- No other activities that are illegal (or show illegal material).

**NOTE:** This is a reference list and is not fully inclusive. If an issue arises that the SASI or ASI deem inappropriate, they may fully exercise the right to take disciplinary action or remove the cadet(s) from the program.

A contract agreeing to these terms is given out at the beginning of the year to be signed by cadets and parents or guardians.

**CADET PROBATION:** Cadet Probation is intended to be corrective in nature and is not intended to be punitive although the result of disciplinary action or cadet probation could impact eligibility for Letterman jackets, promotions, leadership opportunities, and/or awards. Probation determination and probation periods are at the discretion of the instructors and are determined on a case by case basis. Probation letters will be sent home with the cadet and require parent or guardian signature to ensure parents/guardians are aware of the action and the situation leading to the probation action. Any additional violations following placement on probation will likely result in immediate cadet removal from the Corps of Cadets.

**ATTACHMENT 1**

AFJROTC TX-20063  
Hand Receipt

Cadet Name:	Cadet Flight:	Issued By:
Logistic Signature:	Date of Issue:	Return Date Suspense:

ITEM	Size	Qty	Issue Initial	Return Initial
T-Shirt				
Socks				
Shoes				
Short Sleeve Shirt				
Light Weight Blue Jacket				
Service Coat				
Trousers				
Flight Cap				
Tie/Tab				
Belt/Buckle				
PT Shirt				
PT Shorts				
Sweatshirt				
Sweatpants				

I acknowledge receipt of and responsibility for the items described above and will return items in a clean and serviceable condition by the return date indicated.

\_\_\_\_\_  
Printed Name (Issued Cadet)

\_\_\_\_\_  
Signature

WINGS Entry

Date: \_\_\_\_\_

Logistics cadet name: \_\_\_\_\_

SASI/ASI Approval: \_\_\_\_\_

**ATTACHMENT 2****TIVY HIGH SCHOOL AFJROTC LETTERMAN JACKET**

<b>ACTIVITIES</b>		<b>POINTS</b>
<b>TEAMS (Drill, Color Guard, Rocketry, PT, etc.)</b>		
1.	Attend a minimum of 80% of practices in a semester	100
2.	Participate in an event (Posting Colors at Board Meeting, AP demo, etc)	150
3.	Place in a team competition (max of 200 pts per competition) <ul style="list-style-type: none"> <li>• First Place</li> <li>• Second Place</li> <li>• Third Place</li> </ul>	100 75 50
<b>CADET LEADERSHIP/AWARDS</b>		
1	Attend and graduate from a Leadership School	100
2	Attend and graduate from a Leadership School with Honors (Honor Graduate)	150
3	Be a Leadership School Cadet Training Officer / Advisor	200
4	Receive National Award Recognition (AFA, VFW, etc.)	100
5	Earn Outstanding Cadet, Leadership, Superior Performance or Top Performer Award	50
6	Distinguished Unit Award	100
<b>CADET PROMOTION/ACHIEVEMENT</b>		
1	Promoted to Officer Rank (Initial)	100
2	Promoted to NCO Rank (Initial)	50
3	Selected as Cadet of the 6-weeks/semester	100
4	Member of the Outstanding Flight of the Semester	50
5	Receive Academic, Attendance, or Dress and Appearance Ribbon	25
6	Receive the E2C Ribbon with:	
	• Gold Star (100 percentile)	100
	• Silver Star (90 – 99 percentile)	75
	• Bronze Star (80 – 89 percentile)	50
7	Inducted into the Kitty Hawk Air Society (KHAS)	100
8	Completion of subsequent year in KHAS	50
9	Be a member of a KISD recognized National Honor Society	50
10	Earn AFJROTC Sponsored Badge (APT, Rocketry, etc)	50
11	Project Officer/NCO (Christmas Dance, Field Day, Recruiting, Military Ball, etc)	100
<b>CADET INVOLVEMENT</b>		
1	Participate in a parade or retreat ceremony (includes Homecoming parade)	50
2	Attend/Participate in Field Day	50
3	Attend the Christmas Dance	25
4	Attend the Military Ball	75
5	Attend Awards Ceremony/Banquet	75
6	Attend Field Trips	50
7	Recruit a new cadet	50
8	Participate in school/community service project (per hour)*	10
9	Above and Beyond Merit Points **	<b>500</b>

\* Only AFJROTC service projects performed as a TX-20063<sup>rd</sup> Corps can be counted for Letterman Points.

\*\* Instructors can award up to **500** points per school year to a cadet(s) that have performed above and beyond what is normally expected. After a cadet earns 3,000 Letterman Points, and stays in “good-standing” in the year prior to and year the jacket is earned, cadets earn the opportunity to pay for and get their JROTC Letterman jacket. This jacket expense is a 100% cadet expense and is not unit funded. Final Letterman jacket eligibility determination is at SASI and ASI discretion.

ATTACHMENT 3

**AUTHORIZED AIR FORCE JROTC  
BADGES AND INSIGNIA**



Hap Arnold Optional  
Enlisted/Officer Service  
Cap Insignia



OFFICERS  
SERVICE CAP  
INSIGNIA



MODEL ROCKETRY  
BADGE



KITTY HAWK  
AIR SOCIETY  
BADGE



DISTINGUISHED  
CADET BADGE



SHOULDER TAB  
METAL OR CLOTH



GROUND SCHOOL  
BADGE



FLIGHT SOLO  
BADGE



FLIGHT CERTIFICATE  
BADGE

**Cadets may only wear one of these badges on their uniform**



AWARENESS  
PRESENTATION  
TEAM BADGE

Cadets can choose only one badge. Either the APT badge or the Marksmanship Shield. Follow APT placement criteria if cadets wear the Marksmanship Shield.



AEF BADGE



The National Finalists CyberPatriot badge is the only CyberPatriot badge that may be worn. See placement in Attachments 9, 10, 11, and 12. Notes 15 and/or 16.

Badges/Insignia not listed here are unauthorized for wear.

## AUTHORIZED AIR FORCE JROTC BADGES AND INSIGNIA

### Marksmanship Badges – Wear Only One



CMP Awarded Badges



Unit Awarded Badges

If earned choose only one – ***CADETS MAY ONLY WEAR ONE on their uniform.*** Place directly underneath ribbons. Cadets may NOT wear Marksmanship Shield (see below) with Marksmanship Badge.  
Do not wear Marksmanship badges with medals



Marksmanship  
Shield

Choose either the APT or Marksmanship Shield and a Marksmanship Badge.  
Only one may be worn.

Males and females may wear the marksmanship badge (may only wear one) below the ribbons on the blue shirt or service dress uniform or

**Marksmanship badges will not be worn with medals.**

**Badges/Insignia not listed here are unauthorized for wear.**

ATTACHMENT 4

**AIR FORCE JROTC RANK INSIGNIA**

CADET OFFICER RANK



NOTE: Cadet Officer rank used is either cloth epaulet or collar rank, depending on specific uniform worn.

CADET ENLISTED RANK

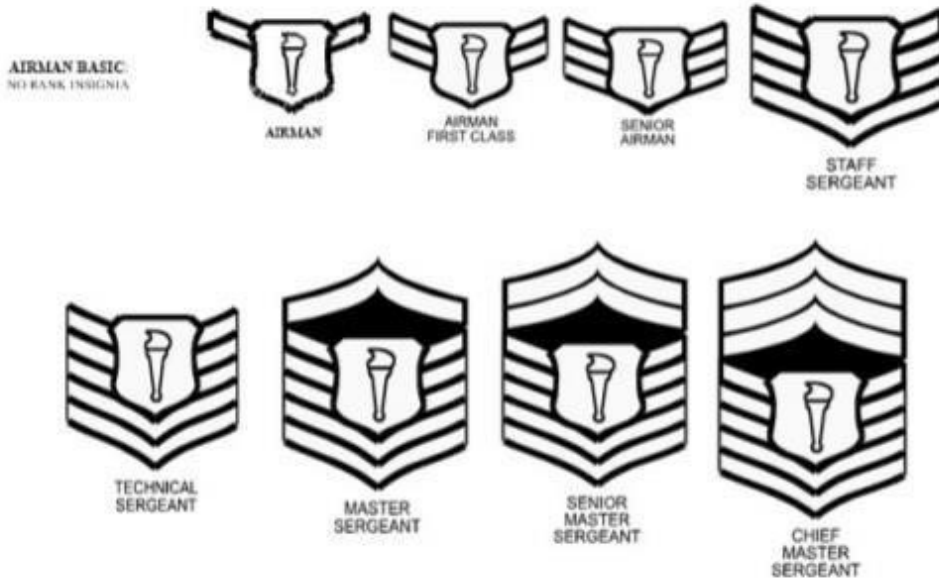

NOTE: Cadet Enlisted rank used is small collar rank only, regardless of uniform worn

Rank insignia not listed here is unauthorized.  
The First Sergeant device is not authorized.

ATTACHMENT 5

**CADET MALE HEADGEAR**



Service Cap – Solid dark Air Force blue color only. Cadet officers may wear the AFJROTC officer hat insignia or the large Hap Arnold Wings insignia. Enlisted cadets may only wear the large Hap Arnold Wings insignia

**FLIGHT CAP\***

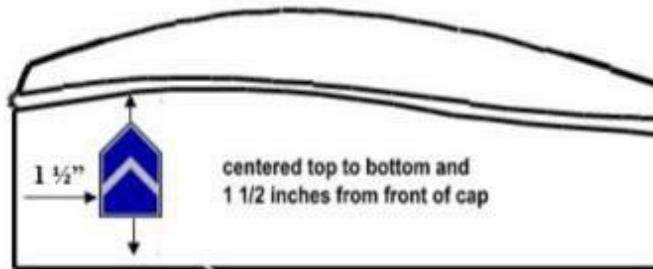

- Enlisted Ranks will have no hat insignia on the flight cap.
- The former officer flight cap emblem will not be worn on the flight cap.



# CADET FEMALE HEADGEAR

## SERVICE CAP

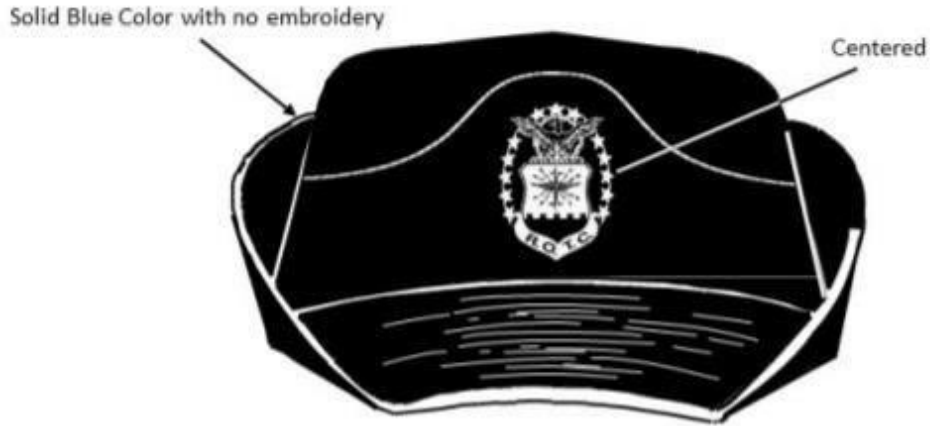

Service Cap - Solid dark Air Force blue color only. Cadet officers may wear the AFJROTC officer hat insignia or the large Hap Arnold Wings insignia. Enlisted cadets may only wear the large Hap Arnold Wings insignia.

## FLIGHT CAP\*

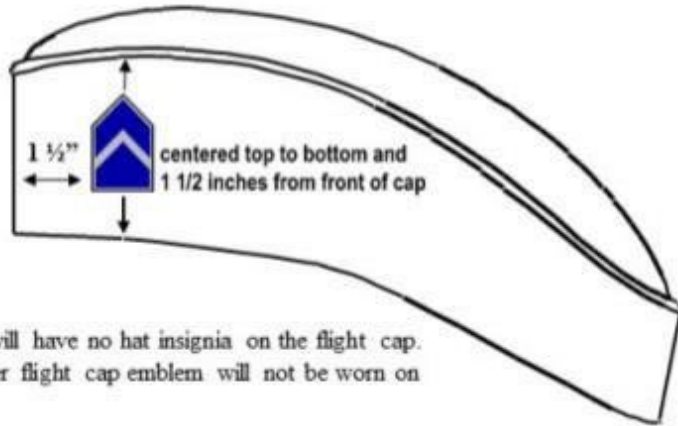

- Enlisted Ranks will have no hat insignia on the flight cap.
- The former officer flight cap emblem will not be worn on the flight cap.

## ATTACHEMENT 6

## CADET BERET HEADGEAR

### BERET



#### Berets.

1. Solid Color white, dark blue or black ONLY, with AFJROTC officer rank insignia or mini-Hap Arnold Insignia pin. The former officer/enlisted flight cap emblems will not be worn on the beret. The wear of a "Beret Flash" or mini unit patch is not authorized.
2. Position headband straight across the forehead, 1 inch above the eyebrows. Drape the top over the right ear. Wear the stiffener with the aligned insignia above the left eye. Adjust ribbon for comfort, tie in a knot, and tuck inside or cut-off. The insignia will be centered, ¼ inch above and parallel to the headband.
3. The wear of a "Beret Flash" is not authorized.

## ATTACHMENT 7

## CADET ABU Male and Female

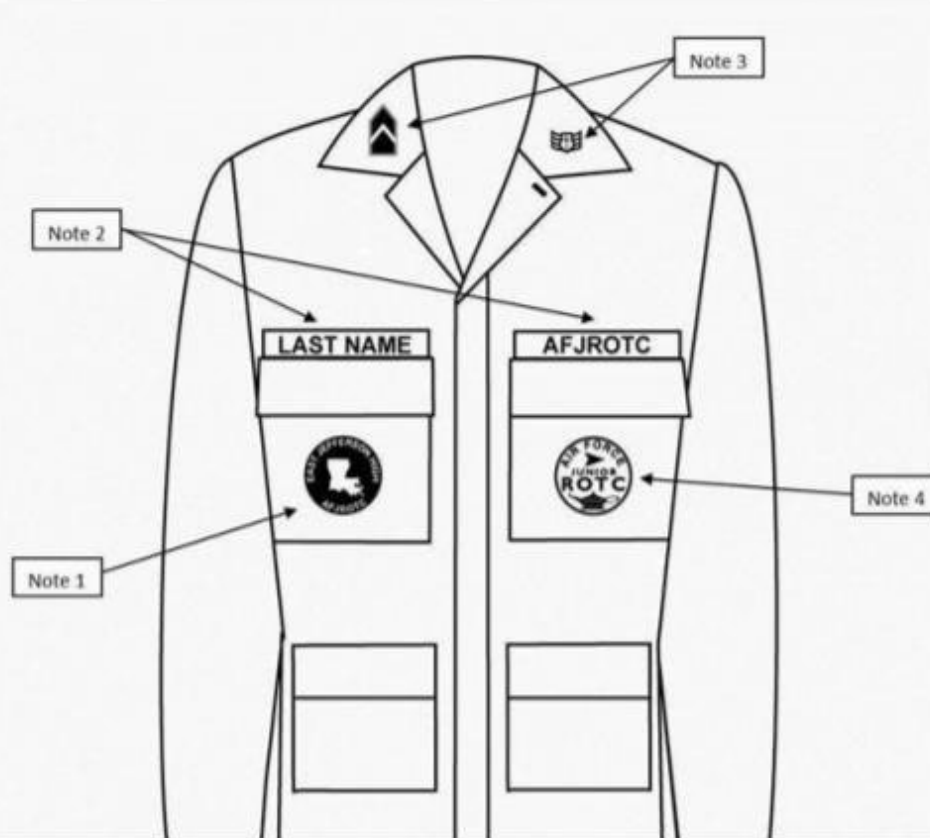

1. Unit patch (optional). If worn, will be placed on right pocket and centered. (AF Funds may not be used to procure unit patches.)
2. Last Name and AFJROTC tapes. Letters are dark blue on digital camo background (mandatory). Tapes are grounded and centered on pockets. Name tape only may be held with Velcro to enable reuse/reissue to a different cadet.
3. Grade insignia (officer or enlisted) (mandatory). Will be worn on the left and right collars, centered on collar and parallel with bottom of collar. Airman Basic have no collar insignia.
4. AFJROTC Patch (white, Lamp of Knowledge): **WHITE patch only (mandatory)**. Will be worn on left pocket and centered.
5. **Berets, ascots, and shoulder cords will not be worn with ABUs.**
6. **ABU sage green boots may be reissued to cadets. Spray boots with disinfectant spray before reissuing ABU boots.**
7. **OCP uniforms are not authorized for wear by AFJROTC cadets at any time.**

## CADET ABU HEADGEAR



Enlisted Cadets will not wear rank on the ABU cap.



Officers will wear rank insignia on the ABU cap.

**No other style of head gear is authorized for wear with ABUs.**

**Exception is for Cadet Leadership Course (CLC) specific headgear that will ONLY be worn during the period of the CLC course.**

## ATTACHMENT 8

## CADET LIGHT WEIGHT BLUE JACKET



NOTE: The epaulet rank is no longer authorized on the lightweight blue jacket.

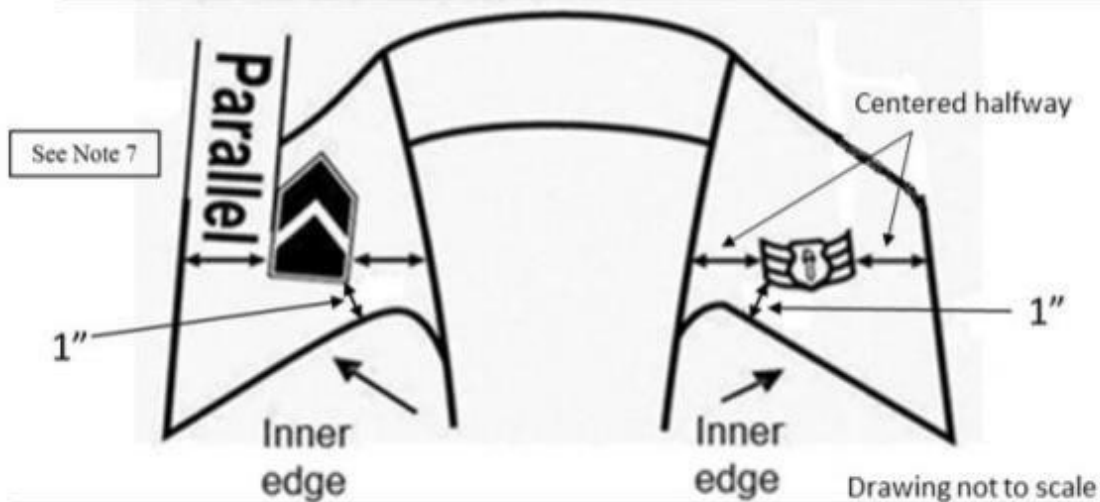

1. Shoulder tabs are centered between unit patch and shoulder seam. If no patch, then 1 inch below shoulder seam.
2. Unit patch on right  $\frac{1}{2}$  to 1 inch below shoulder seam and centered.
3. Grade insignia (officer and enlisted) will be worn on both lapels, mandatory. For placement see Note 7.
4. Optional item: center vertically between the shoulder seam and where the underarm side seam joins the armhole sleeve and center horizontally between the center zipper and the sleeve armhole seam. Per AFJROTCI 36-2010, para 6.1.1.10.1. The words "U.S. Air Force" must appear directly below the symbol, or units can choose to use "AFJROTC." Embroidery expenses must be at no cost to the Air Force.
5. AFJROTC Patch (white, Lamp of Knowledge), mandatory. Center  $\frac{1}{2}$  to 1 inch below left shoulder seam
6. Jacket will be closed to at least the halfway point.
7. Center insignia horizontally on collar. Place 1 inch from bottom of collar and parallel to the outer edge of the collar.
8. Enlisted rank insignia **MUST** be worn on the blue shirt while wearing the light weight jacket.
9. **Ascots and shoulder cords will not be worn on this uniform.**



## ATTACHMENT 9

## CADET MALE SERVICE DRESS

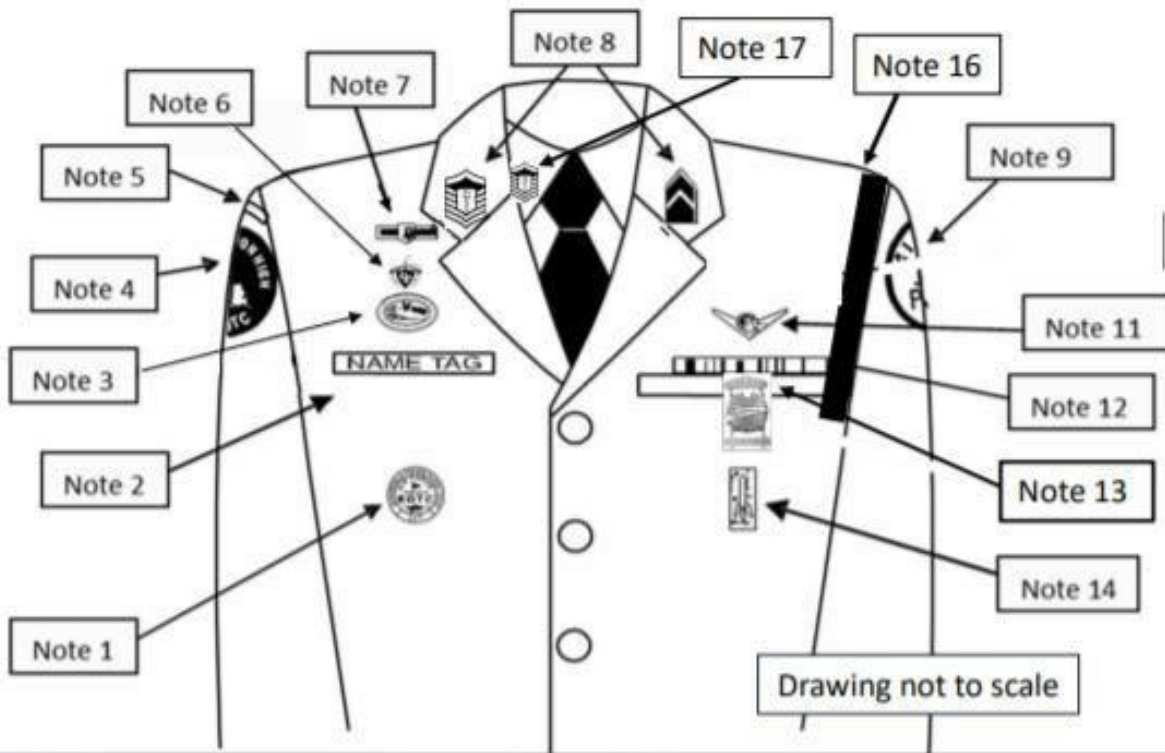

1. Awareness Presentation Team (APT) Badge. Centered 3 inches below the bottom of the silver name tag.
2. Silver Name tag, mandatory. Center on the right side between arm seam and lapel with bottom edge parallel to top of welt pocket.
3. Kitty Hawk Badge. See Note 15 below.
4. Unit patch. Place  $\frac{1}{2}$  to inch below shoulder seam and centered.
5. Shoulder tab: Center between unit patch and shoulder seam. If no patch, then 1 inch below shoulder seam.
6. Aerospace Education Foundation (AEF) Badge. See Note 15 below.
7. Distinguished Cadet Badge. # 1 See Note 15 below.
8. Grade insignia (officer and enlisted) worn on both lapels, mandatory. Place insignia halfway up the seam, resting on but not over it. Bottom of insignia is horizontal with the ground.
9. AFJROTC Patch (white, Lamp of Knowledge), mandatory. Center  $\frac{1}{2}$  to 1 inch below left shoulder seam.
10. Deleted.
11. Cadets will only wear one of the following badges, Aviation Ground School/Unmanned Aircraft Badge, Flight Solo Badge and/or Flight Certificate Badge. See Note 15 below.
12. Ribbons, mandatory. Centered, on but not over edge of pocket. Wear 3 or 4 in a row. Wear all or some ribbons earned.
13. Marksmanship Badge - Marksmanship competition awards/badges may be worn on the AFJROTC uniform. Males and females will wear the badge (may only wear one) below the ribbons on the blue shirt or service dress uniform. **Marksmanship badges will not be worn with medals.**
14. Model Rocketry Badge. Worn 2 inches below the pocket.
15. Except marksmanship badge. Wear first badge placed  $\frac{1}{8}$  inch above silver name tag or ribbons and is centered horizontally. Additional badges are placed  $\frac{1}{8}$  inch above previous badge. Order of precedence for badges are as show on the diagram. Distinguished Cadet Badge, then the AEF Badge, then the Kitty Hawk Badge and lastly the CyberPatriot National Finalist Badge. **No more than two Flight badges are authorized.**
16. Shoulder Cord. No wider than 1 inch and will be grounded to the seam of the left shoulder. May be solid or multi-colored.
17. Enlisted rank insignia **MUST** be worn on the blue shirt while wearing the service dress.
18. **Medals are not authorized for wear on this uniform with ribbons. Ribbons and medals may not be mixed.**

## CADET FEMALE SERVICE DRESS

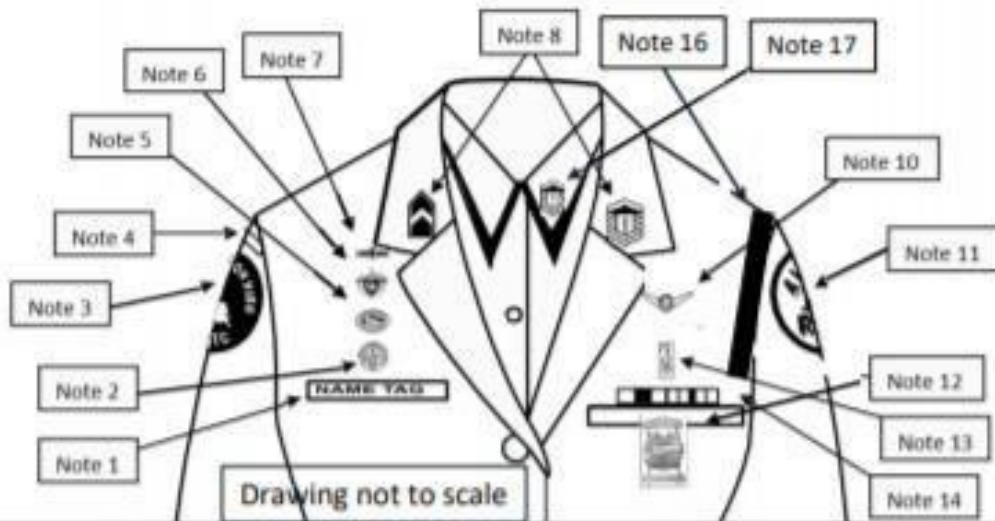

1. Silver Name tag, mandatory. Center on the wearer's right between the sleeve seam and lapel and the bottom of the name tag will be parallel with the bottom of ribbons.
2. Awareness Presentation Team Badge. See Note 15 below.
3. Unit patch. Center  $\frac{1}{2}$  to 1 inch below shoulder seam
4. Shoulder tab: Center between unit patch and shoulder seam. If no patch, then 1 inch below shoulder seam
5. Kitty Hawk Badge. See Note 15 below.
6. Aerospace Education Foundation (AEF) Badge. See Note 15 below.
7. Distinguished Cadet Badge. See Note 15 below.
8. Grade insignia (officer and enlisted) worn on both lapels, mandatory. Place insignia halfway up the seam, resting on but not over it. Bottom of insignia is horizontal with the ground.
9. Deleted
10. Cadets will only wear one of the following badges, Aviation Ground School/Unmanned Aircraft Badge, Flight Solo Badge and/or Flight Certificate Badge. See Note 15 below.
11. AFJROTC Patch (white, Lamp of Knowledge), mandatory. Center  $\frac{1}{2}$  to 1 inch below left shoulder seam.
12. Marksmanship Badge - Marksmanship competition awards/badges may be worn on the AFJROTC uniform. Males and females will wear the badge (may only wear one) below the ribbons on the blue shirt or service dress uniform. **Marksmanship badges will not be worn with medals.**
13. Model Rocketry Badge. See Note 15.
14. Ribbons, mandatory. Center ribbons resting on but not over edge of welt pocket. Wear 3 or 4 in a row. Wear all or some ribbons earned.
15. Except marksmanship badge. Wear first badge placed  $\frac{1}{2}$  inch above silver name tag or ribbons and is centered horizontally. Additional badges are placed  $\frac{1}{2}$  inch above previous badge. Order of precedence for badges are as show on the diagram. Distinguished Cadet Badge, then the AEF Badge, then the Kitty Hawk Badge, then the Awareness Presentation Team Badge and lastly the CyberPatriot National Finalist Badge. **No more than two Flight badges are authorized.**
16. Shoulder Cord. No wider than 1 inch and will be grounded to the seam of the left shoulder. May be solid or multi-colored.
17. Enlisted rank insignia **MUST** be worn on the blue shirt while wearing the service dress.
18. **Medals are not authorized for wear on this uniform with ribbons. Ribbons and medals may not be mixed.**

# CADET MALE BLUE SHIRT

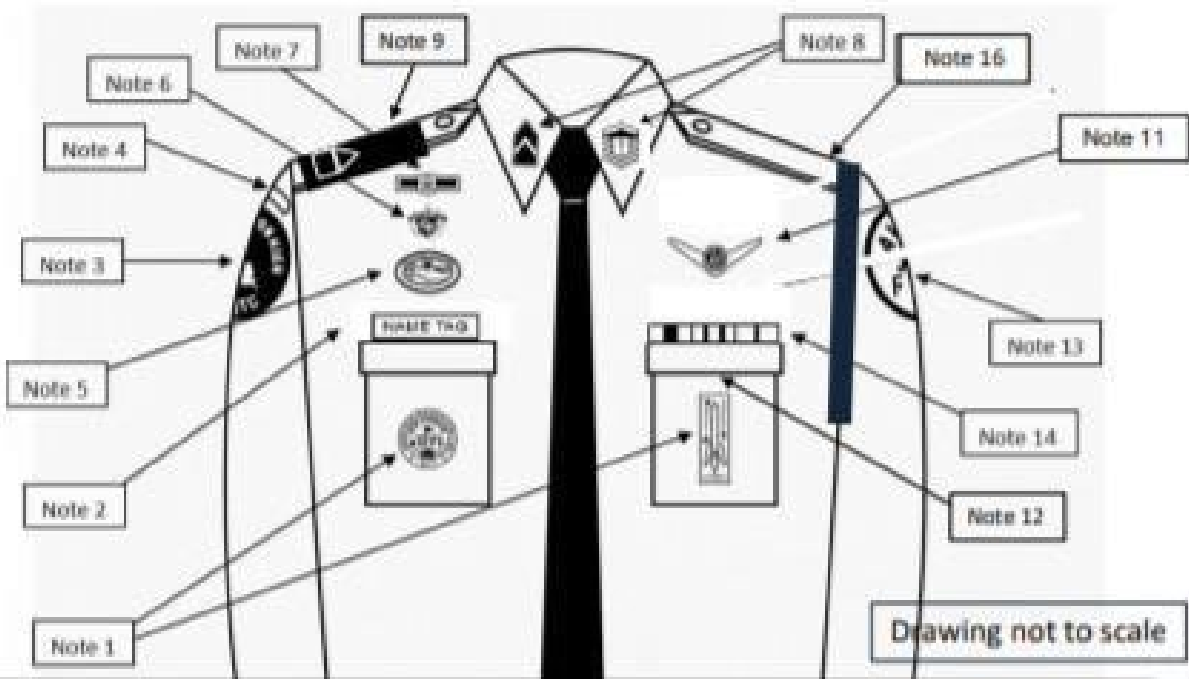

1. Awareness Presentation Team (APT) and Model Rocketry Badge are centered on the pockets on the appropriate sides as displayed above.
2. Name Tag: Mandatory wear. Blue Plastic with white letters. Must be grounded and centered over wearer's right pocket.
3. Unit patch. Centered 3/4 to 1 inch below the shoulder seam.
4. Shoulder tab. Centered between unit patch and shoulder seam. If no patch, then place 1 inch below shoulder seam.
5. Kitty Hawk Badge. See Note 15.
6. Aerospace Education Foundation (AEF) Badge. See Note 15.
7. Distinguished Cadet Badge. See Note 15.
8. Grade insignia, mandatory (officer and enlisted) worn on both left and right collar, centered side to side and top to bottom. Enlisted rank's bottom point of torch points towards the point of the collar. Officer top point of rank aligned with point of collar. Cadet/Avn Basic have no insignia of any kind on the collar.
9. Officers only. When using officer cloth rank on epaulets versus miniature metal rank on collar, place as close as possible to shoulder seam. (Use larger male epaulets only).
10. Deleted
11. Cadets will only wear one of the following badges, Aviation Ground School/Unmanned Aircraft Badge, Flight Solo Badge and/or Flight Certificate Badge. See Note 15 below.
12. Marksmanship competition awards/badges may be worn on the AFJROTC uniform. Males and females will wear the badge (may only wear one) below the ribbons on the blue shirt or service dress uniform. **Marksmanship badges will not be worn with medals.**
13. AFJROTC Patch (Lamp of Knowledge), mandatory. Center 3/4 to 1 inch below left shoulder seam.
14. Ribbons are optional. Wear all, some or no ribbons earned. If worn, ribbons will be centered, resting on, but not over the edge of the pleated pocket on the wearers left.
15. Except marksmanship badges. First badge placed 1/2 inch above name tag or ribbons and is centered horizontally. Additional badges placed 1/2 inch above previous badge. Order of precedence for Badges are as show on the diagram. Distinguished Cadet Badge, then AEF Badge, then Kitty Hawk Badge, and finally the CyberPatriot National Finalist Badge. **No more than two Flight badges are authorized.**
16. Shoulder Cord. No wider than 1 inch and will be grounded to the seam of the left shoulder under epaulet. May be solid or multi-colored.
17. **Medals (regardless of what type) are not authorized for wear on this uniform.**



## CADET FEMALE BLUE SHIRT

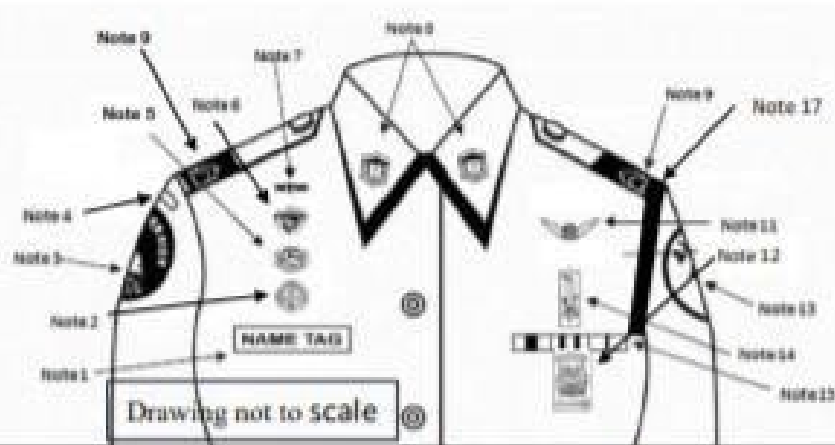

1. Name Tag: Mandatory wear. Blue Plastic with white letters. Without ribbons: centered on right side, parallel to ground and within 1 ½ inches higher/lower than topmost exposed button. With Ribbons: Even with bottom row of ribbons, centered on right side, parallel to ground and within 1 ½ inches higher/lower than topmost exposed button.
2. Awareness Presentation Team (APT) Badge. See Note 16
3. Unit Patch. Centered on sleeve and ½ to 1 inch below shoulder seam.
4. Shoulder Tab (Metal or cloth). Centered between unit patch and shoulder seam, if no patch, then 1 inch below shoulder seam.
5. Kitty Hawk Air Society Badge. See Note 16.
6. Aerospace Education Foundation (AEF) Badge. See Note 16.
7. Distinguished Cadet Badge. See Note 16.
8. Grade insignia, mandatory (officer and enlisted) worn on both left and right collar, centered side to side and top to bottom. Enlisted rank's bottom point of torch points towards the point of the collar. Officer top point of rank aligned with point of collar. Cadet/Amn Basic have no insignia of any kind on the collar
9. Officers only. When using officer cloth rank on epaulets versus miniature metal rank on collar, place as close as possible to shoulder seam. (Use smaller female epaulets only)
10. Deleted.
11. Cadets will only wear one of the following badges, Aviation Ground School/Unmanned Aircraft Badge, Flight Solo Badge and/or Flight Certificate Badge. See Note 16 below.
12. Marksmanship Badge - Marksmanship competition awards/badges may be worn on the AFJROTC uniform. Males and females will wear the badge (may only wear one) below the ribbons on the Blue shirt or service dress uniform. **Marksmanship badges will not be worn with medals.**
13. AFJROTC Patch (white, Lamp of Knowledge), mandatory. Center ½ to 1 inch below left shoulder seam
14. Model Rocketry Badge. See Note 16.
15. Ribbons are optional. Wear all, some or no ribbons earned. If worn, center ribbons on wearer's left, parallel with ground. Align bottom of the ribbons with the bottom of the name tag.
16. Except marksmanship badge. Wear first badge placed ½ inch above silver name tag or ribbons and is centered horizontally. Additional badges are placed ½ inch above previous badge. Order of precedence for badges are as show on the diagram. Distinguished Cadet Badge, then the AEF Badge, then the Kitty Hawk Badge, then the Awareness Presentation Team Badge and lastly the CyberPatriot National Finalist Badge. **No more than two Flight badges are authorized.**
17. Shoulder Cord. No wider than 1 inch and will be grounded to the seam of the left shoulder under the epaulet. May be solid or multi-colored.
18. Medals (regardless of what type) are not authorized for wear on this uniform.

### ATTACHMENT 11

## FLIGHT SUIT (Male and Female)

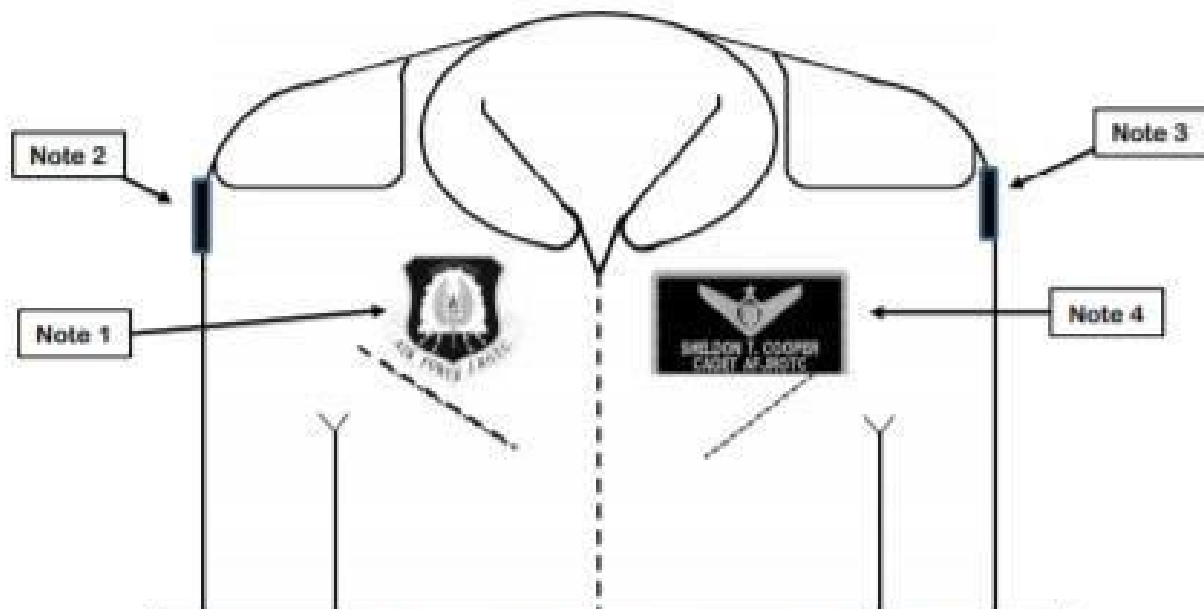

1. \* AFJROTC Command Patch (mandatory). Velcro attached. This style of patch may only be worn on the Flight Suit. Cadets can only wear **ONE** ground school, flight solo or flight certificate badges upon successful completion those programs (See Ops Supplement, Chapter 7, paras 7.2.1, 7.2.2 and 7.2.3).
  2. The unit patch will be worn on the right sleeve (shoulder) of the Flight Suit, if the unit patch is unavailable then the white, Lamp of Knowledge, AFJROTC Patches will not be sewn directly onto the flight suit, all patches must be attached using Velcro.
  3. \* American Flag Patch (mandatory) on left shoulder. Patches will not be sewn directly onto the flight suit, all patches must be attached using Velcro.
  4. \* Cadet Name Patch (mandatory). Velcro attached. Black background with silver border (if unit has a unit patch, units may substitute background color/border with unit patch colors). Cadet Name Badge – Top line will be Cadet Name and second line will be "CADET AFJROTC". Patches will not be sewn directly onto the flight suit, all patches must be attached using Velcro.
  5. Flight Suits are authorized for those cadets that are currently enrolled in or that have successfully completed AFJROTC aviation honors ground school, have been awarded the aviation ground school/unmanned aircraft badge, flight solo badge, flight certificate badge or have successfully completed the AFJROTC Flight Academy program.
- Flight patches and Velcro may be purchased from a vendor using MilPer funds.
  - Flight Suits maybe purchased through WINGS/FEDMALL (contact HQ Logistics for assistance.)

## ATTACHMENT 12

## Semi-Formal Dress Uniform

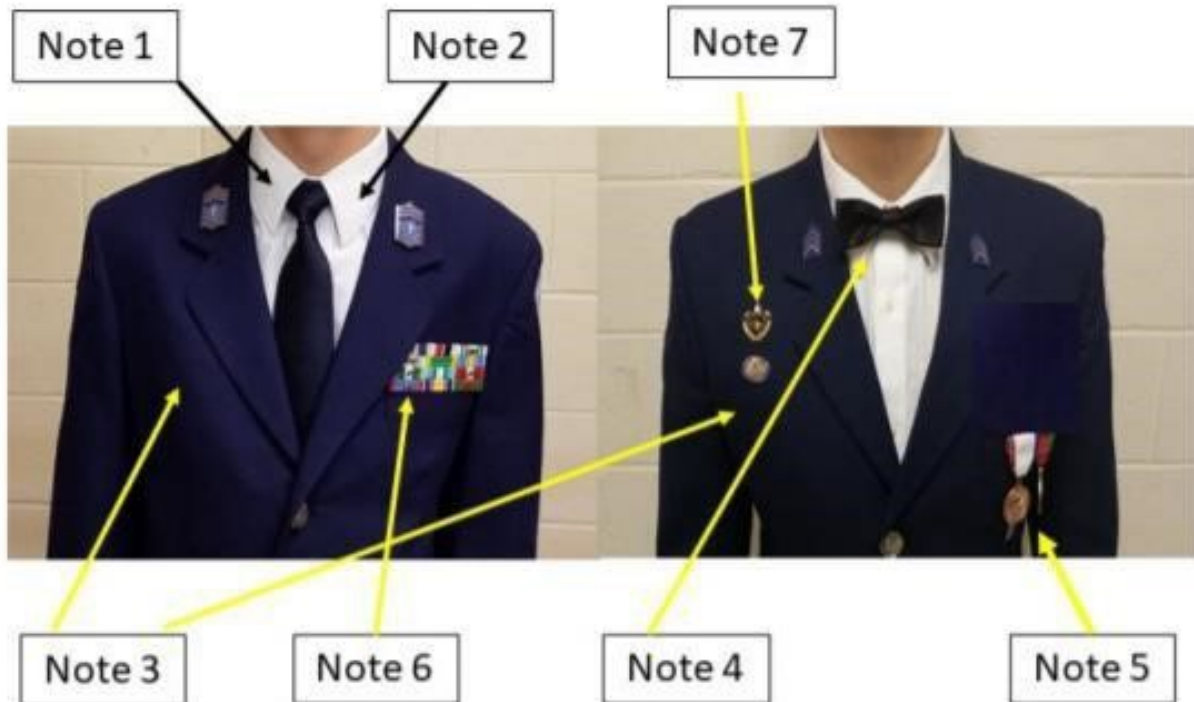

1. The blue or white long-sleeve shirt will be plain, knit or woven, commercial type with a short or medium point collar, with button or French cuffs.
2. Enlisted members do not need to wear two sets of ranks on the semi-formal uniform.
3. The Silver Name Tag will not be worn on the semi-formal dress uniform.
4. Black or Blue bow tie may be worn with the semi-formal uniform (white shirt only).
5. Large medals will be worn on the semi-formal uniform coat  $\frac{1}{2}$  inch below the top of the welt of the pocket, centered on the pocket. If medals are worn, ribbons will not be worn (no mixing).
6. AFJROTC ribbons may be worn on the semi-formal uniform. If ribbons are worn, medals will not be worn (no mixing).
7. Authorized badges may be worn on the semi-form dress uniform. If medals are worn, badges that are normally worn directly under the ribbon rack will not be worn.
8. Headgear is not worn with the semi-formal dress uniform.
9. Per Chapter 7 para 7.8.4.8. **Mess Dress Uniforms are not authorized for wear by AFJROTC cadets.**



## ATTACHMENT 13

## Sample Exhibition Uniform



$\frac{3}{4}$  inch  
stripe

1. Solid Color white, dark blue or black ONLY, with AFJROTC officer rank insignia or mini-Hap Arnold Insignia pin. The former officer/enlisted flight cap emblems will not be worn on the beret. The wear of a "Beret Flash" or mini unit patch is not authorized.
2. Shoulder Cord. Cadets are authorized to wear one shoulder cord on the left shoulder. This will be a single "infantry" style cord, without metal tips, no more than 1-inch wide. On the blue shirt the cord will be under the epaulet, grounded to the left shoulder seam and pinned to the shoulder with the pin hidden beneath the cord. May be solid or multi-colored.
3. Blue/Silver Name Tags and ribbons may be omitted on uniforms where a drill rifle or other equipment may damage the item or injure the performing member. **This does not apply to uniforms worn during regular uniform days.**
4. Blue pants may be modified to have a  $\frac{3}{4}$  inch stripe on the outside length of the pants, silver, blue, or black only. **These items will not be worn on regular uniform days.**
5. Solid color ascots may be worn (embroidery or a unit patch is authorized on the ascot), colors may be locally-determined (school colors), but must be conservative and in good taste, and defined in the Cadet Guide or Unit Operations Instruction. **Ascots will not be worn on regular uniform days.**
6. **Embroidery on the Air Force blue drill team uniform is not authorized, i.e., on the back of the blue shirt collar or shoulder yoke.**
7. **Specialized unit rank/shoulder boards are not authorized.**
8. **Wrist bands are not authorized.**
9. AFJROTC Patch (white, Lamp of Knowledge), mandatory. Center  $\frac{1}{2}$  to 1 inch below left shoulder seam.
10. **Black Boots/corfams may be issued on an as required basis to the unit Color Guard or Drill Team. This is for restricted use and is not intended for use across unit's entire cadet corps. Black boots/corfams may be reissued to cadets. Spray boots/corfams with disinfectant spray before reissuing.**

de Effective: 16 Aug 2021



## Sample Exhibition Uniform



1. Women's Service Caps may be worn with the Hap Arnold Wings insignia or Officer Service Cap may also be worn with the large officer service cap insignia large officer's. Service Caps (wheel and bucket hats) will be a **solid color and free of any embroidery.**
2. Shoulder Cord. Cadets are authorized to wear one shoulder cord on the left shoulder. This will be a single "infantry" style cord, without metal tips, no more than 1-inch wide. On the blue shirt the cord will be under the epaulet, grounded to the left shoulder seam and pinned to the shoulder with the pin hidden beneath the cord. May be solid or multi-colored.
3. Blue/Silver Name Tags and ribbons may be omitted on uniforms where a drill rifle or other equipment may damage the item or injure the performing member. **This does not apply to uniforms worn during regular uniform days.**
4. Blue pants may be modified to have a 3/4 inch stripe on the outside length of the pants, silver, blue, or black only. **These items will not be worn on regular uniform days.**
5. Solid color ascots may be worn (embroidery or a unit patch is authorized on the ascot), colors may be locally-determined (school colors), but must be conservative and in good taste, and defined in the Cadet Guide or Unit Operations Instruction. **Ascots will not be worn on regular uniform days.**
6. **Embroidery on the Air Force blue drill team uniform is not authorized, i.e., on the back of the blue shirt collar or shoulder yoke.**
7. **Specialized unit rank/shoulder boards are not authorized.**
8. A 1/2 inch silver, dark blue, or black only sleeve braid, 3 inches from the end of the sleeve, may be worn.
9. AFJROTC Patch (white, Lamp of Knowledge), mandatory. Center 1/2 to 1 inch below left shoulder seam.
10. **Black Boots/corfams may be issued on an as required basis to the unit Color Guard or Drill Team. This is for restricted use and is not intended for use across unit's entire cadet corps. Black boots/corfams may be reissued to cadets. Spray boots/corfams with disinfectant spray before reissuing.**

ATTACHMENT 14

**Sample Uniform Pictures**  
**Cadets will not wear both officer and enlisted rank on their uniforms ... these are sample pictures only**

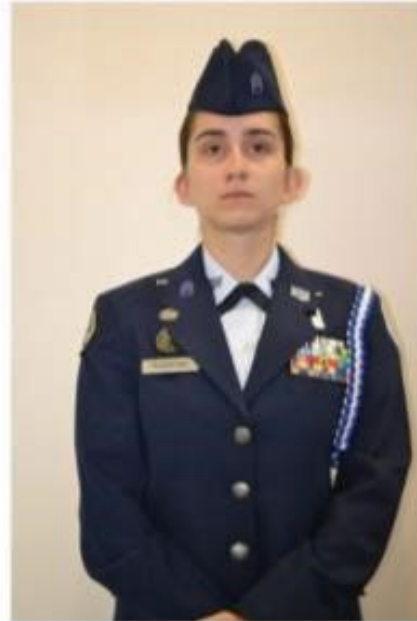

## Sample Uniform Pictures





# Sample Uniform Pictures



Local Purchased PFT Gear



FEDMALL Purchased Air Force PTG

FEDMALL  
Purchased Air Force  
Sweat Shirt and  
Pants



**ATTACHMENT 15**

**AFMAN 36-2203  
20 November 2013, Incorporating Change 1 29 Feb 2016  
Chapter 3**

**INDIVIDUAL (DRILL) INSTRUCTION**

**3.1. Positions and Movements.** This chapter explains, by word and picture, certain basic positions and movements.

**3.2. Position of Attention.** To come to attention, bring the heels together smartly and on line. Place the heels as near each other as the conformation of the body permits, and ensure the feet are turned out equally, forming a 45-degree angle. Keep the legs straight without stiffening or locking the knees. The body is erect with hips level, chest lifted, back arched, and shoulders square and even. Arms hang straight down alongside the body without stiffness, and the wrists are straight with the forearms. Place thumbs, which are resting along the first joint of the forefinger, along the seams of the trousers or sides of the skirt. Hands are cupped (but not clenched as a fist) with palms facing the leg (figure 3.1). The head is kept erect and held straight to the front with the chin drawn in slightly so the axis of the head and neck is vertical; eyes are to the front, with the line of sight parallel to the ground. The weight of the body rests equally on the heels and balls of both feet, and silence and immobility are required.



**Figure 3.1. Position of Attention.**

### 3.3. Rest Positions:

3.3.1. Execute rests (parade rest, at ease, rest, and fall out) from a halt and only from the position of attention as follows:

3.3.1.1. **Parade Rest.** The command is **Parade, REST.** On the command **REST**, the airman will raise the left foot from the hip just enough to clear the ground and move it smartly to the left so the heels are 12 inches apart, as measured from the inside of the heels. Keep the legs straight, but not stiff, and the heels on line. As the left foot moves, bring the arms, fully extended, to the back of the body, uncupping the hands in the process; and extend and join the fingers, pointing them toward the ground. The palms will face outwards. Place the right hand in the palm of the left, right thumb over the left to form an “X” (figure 3.2). Keep head and eyes straight ahead, and remain silent and immobile.

**Figure 3.2. Parade Rest.**



3.3.1.2. **At Ease.** The command is **AT EASE.** On the command **AT EASE**, airmen may relax in a standing position, but they must keep the right foot in place. Their position in the formation will not change, and silence will be maintained.

3.3.1.3. **Rest.** The command is **REST.** On the command **REST**, the same requirements for at ease apply, but moderate speech is permitted.

3.3.1.4. **Fall Out.** The command is **FALL OUT**. On the command **FALL OUT**, individuals may relax in a standing position or break ranks. They must remain in the immediate area, and no specific method of dispersal is required. Moderate speech is permitted.

3.3.2. To resume the position of attention from any of the rests (except fall out), the command is (for example) **Flight, ATTENTION**. On the command **Flight**, the airmen assume the position of parade rest; and at the command **ATTENTION**, they assume the position of attention.

**3.4. Facings Movements.** Execute facing movements from a halt, at the position of attention, and in the cadence of quick time. Perform facing movements in two counts.

3.4.1. **Right (Left) Face.** The commands are **Right (Left), FACE**. On the command **FACE**, raise the right (left) toe and left (right) heel slightly and pivot 90 degrees to the right (left) on the ball of the left (right) foot and the heel of the right (left) foot, assisted by slight pressure on the ball of the left (right) foot. Keep legs straight, but not stiff. The upper portion of the body remains at attention. This completes count one of the movement. Next, bring the left (right) foot smartly forward, ensuring heels are together and on line. Feet should now be forming a 45-degree angle, which means the position of attention has been resumed (figure 3.3). This completes count two of the movement.

**Figure 3.3. Right Face.**



3.4.2. **About Face.** The command is **About, FACE**. On the command **FACE**, lift the right foot from the hip just enough to clear the ground. Without bending the knees, place the ball of the right foot approximately half a shoe length behind and slightly to the left of the heel. Distribute the weight of the body on the ball of the right foot and the heel of the left foot. Keep both legs straight, but not stiff. The position of the foot has not changed. This completes count one of the

movement. Keeping the upper portion of the body at the position of attention, pivot 180 degrees to the right on the ball of the right foot and heel of the left foot, with a twisting motion from the hips. Suspend arm swing during the movement, and remain as though at attention. On completion of the pivot, heels should be together and on line and feet should form a 45-degree angle. The entire body is now at the position of attention (figure 3.4). This completes count two of the movement.

**Figure 3.4. About Face.**

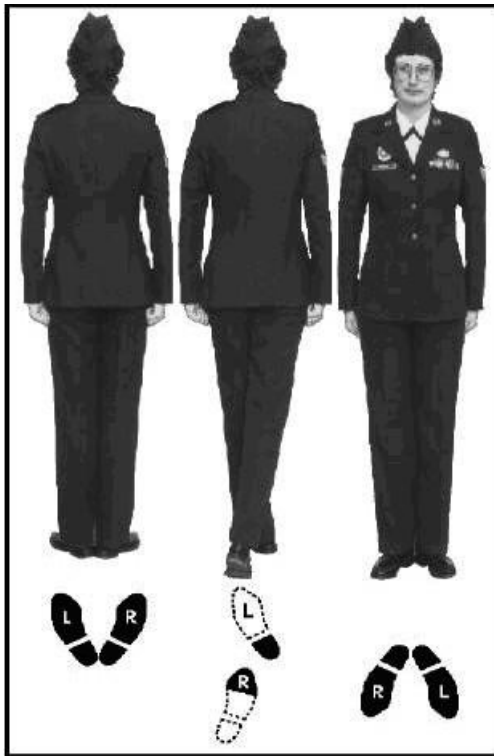

**3.4.3. Half Right (Left) Face.** When instructions are given for 45-degree movements, the command

**Half Right (Left), FACE** may be used. The procedures described in paragraph 3.4.1 are used except each person executes the movement by facing 45 degrees to the right or left.

**3.5. Hand Salute.** This is used for training purposes only. The command is **Hand, SALUTE**, and it is performed in two counts. On the command **SALUTE**, the individual raises the right hand smartly in the most direct manner while at the same time extending and joining the fingers. Keep the palm flat and facing the body. Place the thumb along the forefingers, keeping the palm flat and forming a straight line between the fingertips and elbows (figure 3.5). Tilt the palm slightly toward the face. Hold the upper arm horizontal, slightly forward of the body and parallel to the ground. Ensure the tip of the middle finger touches the right front corner of the headdress. If wearing a non-billed hat, ensure the middle finger touches the outside corner of the right eyebrow or the front corner of glasses. The rest of the body will remain at the position of attention. This is count one of the movement. To complete count two of the movement, bring the arm smoothly and

smartly downward, retracing the path used to raise the arm. Cup the hand as it passes the waist, and return to the position of attention.

**Figure 3.5. Hand Salute.**



## ATTACHMENT 16

## ACRONYMS

AAR	After Action Report
ADMIN	Administration or Administrative
AFJROTC	Air Force Junior Reserve Officer Training Corps
AFJROTCI	Air Force Junior Reserve Officer Training Corps Instruction
AFROTC	Air Force Reserve Officer Training Corps ( <i>College</i> )
ASAP	As Soon As Possible
ASI	Aerospace Science Instructor
Cadet Leadership	Corps Command Staff, Flight Commanders and Flight Sergeants
Cadet Command Staff	Corps CC, Vice CC, Deputies (DCO, DCS, DCT), SEA.
Corps CC or Group CC	Cadet Corps Commander or Commander of the Corps of Cadets
c/NCOIC	Cadet Noncommissioned Officer-in-Charge
c/OIC	Cadet Officer-in-Charge
DCO	Cadet Deputy Commander for Operation (Ops Squadron Cmdr)
DCS	Cadet Deputy Commander for Support (Support Squadron Cmdr)
DCT	Cadet Deputy Commander for Training (Training Squadron Cmdr)

EOD	End of Day
Flt CC	Flight Commander
Flt Sgt	Flight Sergeant
LOC	Letter of Counseling
MR	Memo for Record
NCO	Non-Commissioned Officer
NCOIC	Non-Commissioned Officer In Charge
NLT	No Later Than
OIC	Officer in Charge
OPS	Cadet Corps Operations Commander
PA	Public Affairs Officer
POC	Point of Contact
RHIP	Rank Has Its Privileges
ROTC	Reserve Officer Training Corps (College only)
SASI	Senior Aerospace Science Instructor
SEA	Senior Enlisted Advisor
SNCO	Senior Non-Commissioned Officer (MSgt – CMSgt)
SASI	Special Assistant to the Senior Instructor / Aide-de-Camp
SSAN	Social Security Account Number
TDY	Temporary Duty ( <i>Active Duty</i> )
THS	Tivy High School ( <i>Tivy Pride</i> )
UIL	Unfavorable Information List (Reporting Period Failure List)
UMD	Unit Manning Document
Vice or Vice Group	Vice Group Commander





















































ATTACHMENT 17

## Insignia of the United States Armed Forces – Enlisted

E-1	E-2	E-3	E-4	E-5	E-6	E-7	E-8	E-9	SERIES RELATED RANKS			
<b>ARMY</b>												
no insignia												
Private E-1 (PV1)	Private E-2 (PV2)	Private First Class (FFC)	Corporal (CPL) Specialist (SFC)	Sergeant (SGT)	Staff Sergeant (SSG)	Sergeant First Class (SFC)	Master Sergeant (MSG)	First Sergeant (1SG)	Sergeant Major (SGM)	Command Sergeant Major (CSM)	Sergeant Major of the Army (SMA)	
<b>MARINES</b>												
no insignia												
Private (Pvt)	Private First (PFC)	Lance Corporal (LCpl)	Corporal (Cpl)	Sergeant (Sgt)	Staff Sergeant (SSgt)	Gunnery Sergeant (GySgt)	Master Sergeant (MSgt)	First Sergeant (1stSgt)	Master Gunnery Sergeant (MGMgt)	Sergeant Major (SgtMaj)	Sergeant Major of the Marine Corps (SgtMajMC)	
<b>NAVY</b>												
no insignia												
Seaman Recruit (SR)	Seaman Apprentice (SA)	Seaman (SN)	Petty Officer Third Class (PO3)	Petty Officer Second Class (PO2)	Petty Officer First Class (PO1)	Chief Petty Officer (CPO)	Senior Chief Petty Officer (SCPO)	Master Chief Petty Officer (MCPO)	Force or Fleet Chief Petty Officer (FORN/C) (FLTMC)	Master Chief Petty Officer of the Navy (MCPON)		
<b>AIR FORCE</b>												
no insignia												
Airman Basic (AB)	Airman (Amm)	Airman First Class (A1C)	Senior Airman (SrA)	Staff Sergeant (SSgt)	Technical Sergeant (TSgt)	Master Sergeant (MSgt)	First Sergeant (E-7)	Senior Master Sergeant (SMSgt)	Chief Master Sergeant (CMSgt)	First Command Master Sergeant (E-9)	Command Master Sergeant (CCM)	Chief Master Sergeant of the Air Force (CMSAF)
<b>COAST GUARD</b>												
Seaman Recruit (SR)	Seaman Apprentice (SA)	Seaman (SN)	Petty Officer Third Class (PO3)	Petty Officer Second Class (PO2)	Petty Officer First Class (PO1)	Chief Petty Officer (CPO)	Senior Chief Petty Officer (SCPO)	Master Chief Petty Officer (MCPO)	Command Master Chief (CMC)	Master Chief Petty Officer of the Coast Guard (MCPON-CG)		
<b>Warrant</b>												
<b>ARMY</b>					<b>NAVY</b>							
Warrant Officer (WO1)	Chief Warrant Officer (CW2)	Chief Warrant Officer (CW3)	Chief Warrant Officer (CW4)	Chief Warrant Officer (CW5)	Chief Warrant Officer (CW2)	Chief Warrant Officer (CW3)	Chief Warrant Officer (CW4)	Chief Warrant Officer (CW4)	Chief Warrant Officer (CW4)			
<b>MARINES</b>					<b>COAST GUARD</b>							
Warrant Officer (WO)	Chief Warrant Officer (CW02)	Chief Warrant Officer (CW03)	Chief Warrant Officer (CW04)	Chief Warrant Officer (CW05)	Chief Warrant Officer (CW02)	Chief Warrant Officer (CW03)	Chief Warrant Officer (CW03)	Chief Warrant Officer (CW04)	Chief Warrant Officer (CW04)			



## Insignia of the United States Armed Forces - Officer

O-1	O-2	O-3	O-4	O-5	O-6	O-7	O-8	O-9	O-10	SPECIAL
<b>ARMY</b>										
 Second Lieutenant (2LT)	 First Lieutenant (1LT)	 Captain (CPT)	 Major (MAJ)	 Lieutenant Colonel (LTC)	 Colonel (COL)	 Brigadier General (BG)	 Major General (MG)	 Lieutenant General (LTG)	 General (GEN)	 General of the Army (GA)
<b>MARINES</b>										
 Second Lieutenant (2ndLt)	 First Lieutenant (1stLt)	 Captain (Capt)	 Major (Maj)	 Lieutenant Colonel (LtCol)	 Colonel (Col)	 Brigadier General (BGen)	 Major General (MajGen)	 Lieutenant General (LtGen)	 General (Gen)	
<b>NAVY</b>										
 Ensign (ENS)	 Lieutenant Junior Grade (LTJG)	 Lieutenant (LT)	 Lieutenant Commander (LCDR)	 Commander (CDR)	 Captain (CAPT)	 Rear Admiral Lower Half (RADM)(L)	 Rear Admiral Upper Half (RADM)(U)	 Vice Admiral (VADM)	 Admiral (ADM)	 Fleet Admiral (FADM)
<b>AIR FORCE</b>										
 Second Lieutenant (2d Lt)	 First Lieutenant (1st Lt)	 Captain (Capt)	 Major (Maj)	 Lieutenant Colonel (Lt Col)	 Colonel (Col)	 Brigadier General (Brig Gen)	 Major General (Maj Gen)	 Lieutenant General (Lt Gen)	 General (Gen)	
<b>COAST GUARD</b>										
 Ensign (ENS)	 Lieutenant Junior Grade (LTJG)	 Lieutenant (LT)	 Lieutenant Commander (LCDR)	 Commander (CDR)	 Captain (CAPT)	 Rear Admiral Lower Half (RADM)(L)	 Rear Admiral Upper Half (RADM)(U)	 Vice Admiral (VADM)	 Admiral (ADM)	

ATTACHMENT 18

**TX-20063 – Leadership Cord Tracker**

<b>Position</b>	<b>Cord Type / Color(s)</b>
<b>Corps Commander (CC)</b>	<b>Metallic Silver</b>
<b>Corps Commander Advisor</b>	<b>Black &amp; Grey</b>
<b>Corps Vice Commander (CV)</b>	<b>Navy Blue &amp; Metallic Silver</b>
<b>Inspector General (IG)</b>	<b>Royal Blue &amp; Gold</b>
<b>Chief Enlisted Advisor (CEA)</b>	<b>Royal Blue</b>
<b>Deputy Commander Operations (DCO)</b>	<b>Navy &amp; Gray</b>
<b>Deputy Commander Support (DCS)</b>	<b>Navy &amp; Gray</b>
<b>Deputy Commander Training (DCT)</b>	<b>Navy &amp; Gray</b>
<b>Logistics Commander</b>	<b>Kelly Green &amp; White</b>
<b>Kitty Hawk Air Society Commander</b>	<b>Black &amp; Dark Gold</b>
<b>Color Guard Commander</b>	<b>Dark Gold &amp; White</b>
<b>Drill Team Commander</b>	<b>Black &amp; Royal Blue</b>
<b>Rocketry Commander</b>	<b>Maroon</b>
<b>Quad Commander</b>	<b>Maroon &amp; Gold</b>
<b>Saber Team Commander</b>	<b>Gray</b>
<b>Flight Commander</b>	<b>Royal Blue &amp; White</b>
<b>Flight Sergeants</b>	<b>Jay Blue</b>
<b>Guide</b>	<b>Infantry Blue</b>

## ATTACHMENT 19

## UPDATE TO AFJROTC DRESS &amp; PERSONAL APPEARANCE GUIDELINES (Aug 2021)

AFI 36-2903, Incorporating Change 1, dated 25 June 2021

## 7.8. Specific Female Cadet Grooming Guidelines.

7.8.1. Hair-Female. Hair-Female. No minimum hair length, to a maximum bulk of 4 inches from scalp and allows proper wear of headgear. Hair will end above the bottom edge of collar and will not extend below an invisible line drawn parallel to the ground, both front to back and side to side unless pulled back and secured or worn in an authorized ponytail/equivalent or long braid(s). If hair is pulled back and secured behind the head, radius will not exceed 6 inches from the point where the hair is gathered (i.e., no more than 6 inches to the left and 6 inches to the right, 12 inches total width; and 6 inches protruding from where hair is gathered) and must allow for proper wear of headgear. One or two braids or a single ponytail/equivalent may be worn down the member's back with length not extending below a horizontal line running between the top of each sleeve inseam at the under arm through the shoulder blades. The braid(s) or ponytail/equivalent cannot be worn over the shoulder or pulled in front of the body. They shall extend down the member's back. Bangs, or side-swiped hair, may touch eyebrows but will not touch or cover eyes. When in doubt, assess correct length of hair with Airman standing in the position of attention. See **Figure 3.2** for examples of female hair standards. **Exception:** While wearing the Physical Training Gear (PTG), long hair will be secured but may have loose ends and may extend below a horizontal line running between the top of each sleeve inseam at the under arm through the shoulder blades.

7.8.1.1. Pinned-up hair should be styled in a manner that prevents loose ends from extending upward on the head. When hair is in a bun, the bun must be a single bun; all loose ends must be tucked in and secured. When hair is in a ponytail/equivalent, it must be a single ponytail/equivalent that does not extend below a horizontal line running between the top of each sleeve inseam at the under arm through the shoulder blades.

7.8.1.2. Will be clean, well-groomed, present a professional appearance, allow proper wear of headgear and conform to safety requirements. Will *not* contain excessive amounts of grooming aids (e.g., gel, mousse, pomade, or moisturizer), appear lopsided, touch either eyebrow, or end below an imaginary line across the forehead at the top of the eyebrows that is parallel to the ground. If applied, dyes, tints, bleaches and frostings must result in natural hair colors. Examples of natural hair colors are brown, blonde, brunette, natural red, black or grey. All cadets are authorized to wear hair in a natural color regardless of their natural born hair color. Prohibited hair color examples (*not* all inclusive) are burgundy, purple, orange, fluorescent or neon colors. SASIs may temporarily authorize cancer patients to wear approved caps (black/tan) due to a temporary medical condition (i.e., radiation/chemotherapy).

7.8.1.3. Hair accessories. If worn, hair accessories (e.g., fabric scrunches, hairpins, combs, clips, headbands, elastic bands, barrettes, etc.) must match hair color. Black hair accessories are authorized regardless of hair color. Hair must still comply with bulk and appearance standards. Headgear must fit properly. Headbands or fabric scrunchies will not exceed one-inch in width. Ornaments are *not* authorized (i.e., ribbons, beads, jeweled pins).



**Scrunchie**



**Hair Clips**

7.8.1. Locs, braids, twists, micro-braids, French braids, Dutch braids and cornrows are authorized. Locs are defined as portions of hair that have been intentionally or unintentionally fused together to form a loc or locs. A braid or twist is two or more portions of interwoven hair. If adding additional hair, it must be a natural- looking color (similar to the individual's hair color) and conservative (moderate, being within reasonable limits; not excessive or extreme). Multiple locs, braids, twists or cornrows may come together down the back in one or two braids or a single ponytail. Hair must not exceed bulk standard (see figure 3.2). Headgear must fit properly.

7.8.2. All locs, braids and twists, when worn will be of uniform dimension, no wider than one inch, with natural spacing between the locs, braids, and twists and must be tightly interwoven to present a neat, professional and well-groomed appearance. When worn, multiple locs, braids, or twists shall be of uniform dimension, small in diameter (approximately ¼ inches), show no more than ¼ inch of scalp between the locs, braids, or twists and must be tightly interwoven to present a neat, professional appearance.

7.8.3. A braid/twist must continue to the end of the hair without design and following the contour of the head, and may be worn loose or in a secured style within hair standards in paragraph 7.10.1 above. **Exception:** Micro-braids or twists are not required to continue to the end of the hair.

**Figure 3.2. Female Hair Style Examples**

**Authorized Female Ponytails/equivalent and long braid(s) Hair Styles Examples.**



**Ponytail/Pull-through Ponytail Style/Braided Ponytail**





**Braided Ponytails/Multiple Braids in a Single Ponytail**



**Pulled back secured and**

**does not exceed 6-inch radius**



**Pulled back secured and does not exceed 6-inch radius**



### Two Braids Looped Underneath/Two Braids

#### 7.9. Specific Male Cadet Grooming Guidelines. (See Figure 3.1)

7.9.1. **Men's Hair.** Will be clean, well-groomed, present a professional appearance, allow proper wear of headgear and conform to safety requirements. Will *not* contain excessive amounts of grooming aids (e.g., gel, mousse, pomade, or moisturizer), appear lopsided, touch either eyebrow, or end below an imaginary line across the forehead at the top of the eyebrows that is parallel to the ground. If applied, dyes, tints, bleaches and frostings must result in natural hair colors. Examples of natural hair colors are brown, blonde, brunette, natural red, black or grey. All cadets are authorized to wear hair in a natural color regardless of their natural born hair color.

Prohibited hair color examples (*not* all inclusive) are burgundy, purple, orange, fluorescent or neon colors. SASIs may temporarily authorize cancer patients to wear approved caps (black/tan) due to a temporary medical condition (i.e., radiation/chemotherapy).

7.9.2. **Hair-Male.** Tapered appearance on both sides and the back of the head, both with and without headgear. A tapered appearance is one that when viewed from any angle outlines the member's hair so that it conforms to the shape of the head, curving inward to the natural termination point without eccentric directional flow, twists or spiking. A block-cut is permitted with tapered appearance. Hair will *not* exceed 2 inches in bulk, regardless of length and ¼ inch at natural termination point; allowing only closely cut or shaved hair on the back of the neck to touch the collar. Hair will not touch the ears or protrude under the front band of headgear.

Cleanly shaven heads, military high-and-tight or flat-top cuts are authorized. Prohibited examples (*not* all inclusive) are Mohawk, mullet, cornrows, dreadlocks or etched shapes/design. Cadets may have one (cut, clipped or shaved) front to back, straight-line part, not slanted or curved, on either side of their head, above the temple. Part will not exceed 4 inches length or ¼ inch width. Men are *not* authorized hair extensions. See **figure 3.1** for graphic examples of appropriate sideburns, mustache and male hair standards.



# Air Force and Space Force JROTC Ribbon Chart

 1. Gold Valor Award	 2. Silver Valor Award	 3. Cadet Humanitarian Award	 4. Silver Star Community Service w/Excellence Award	 5. Community Service with Excellence Award	 6. Air Force Association Award
 7. Daedalian Award	 8. Daughters of the American Revolution Award	 9. American Legion Scholastic Award	 10. American Legion General Military Excellence Award	 11. Reserve Organization of America (ROA) Award	 12. Military Officers Association Award
 13. Veterans of Foreign Wars (VFW) Award	 14. National Society United States Daughters of 1812	 15. National Sojourners Award	 16. Scottish Rite, Southern Jurisdiction Award	 17. Military Order of the Purple Heart	 18. Sons of the American Revolution Award
 19. Military Order of World Wars Medal	 20. American Veterans Award	 21. Air Force Sergeants Association	 22. Tuskegee Airman Inc. Award	 23. The Retired Enlisted Association Award	 24. Celebrate Freedom Foundation Award
 25. Air Commando Association Award	 26. Distinguished Unit Award w/Merit	 27. Distinguished Unit Award	 28. Outstanding Organization Award	 29. Outstanding Flight Ribbon	 30. Top Performer Award
 31. Outstanding Cadet Ribbon	 32. Leadership Ribbon	 33. Superior Performance Ribbon	 34. Achievement Ribbon	 35. Academic Ribbon	 36. Cadet Leadership Course Ribbon
 37. Special Teams Placement Ribbon	 38. All-Service National Competition Ribbon	 39. Air Force Nationals Competition Ribbon	 40. Orienteering Ribbon	 41. Leadership Development Requirement (LDR) Leadership Ribbon	 42. Drill Team Ribbon
 43. Color Guard Ribbon	 44. Sabre Team Ribbon	 45. Marksmanship Ribbon	 46. JLAB Ribbon	 47. Cyber Patriot Ribbon	 48. StellarXplorers Ribbon
 49. Raiders Team Ribbon	 50. Military Model Building Ribbon	 51. Unmanned Aircraft Systems (UAS) Ribbon	 52. Robotics Ribbon	 53. Good Conduct Ribbon	 54. Service Ribbon
 55. Health and Wellness Ribbon	 56. Recruiting Ribbon	 57. Activities Ribbon	 58. Attendance Ribbon	 59. Dress and Appearance Ribbon	 60. Longevity Ribbon
	 61. Bataan Death March Memorial Hike Ribbon	 62. Patriotic Flag Ribbon	 63. Resiliency Ribbon	 64-68. CAP Ribbons	