

Print & Go

Math PRACTICE

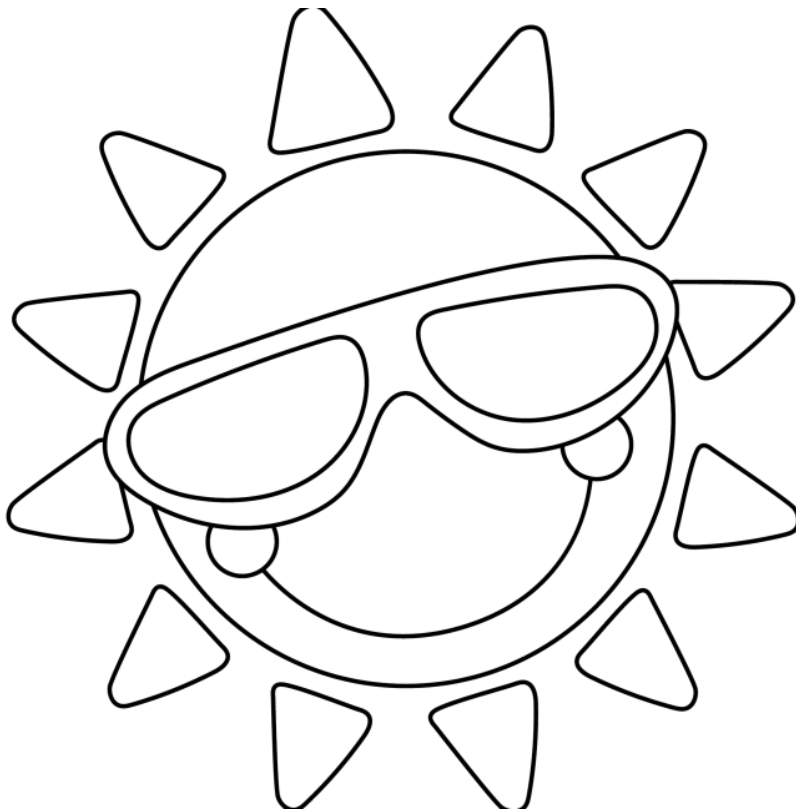

FREE from
The Curriculum Corner

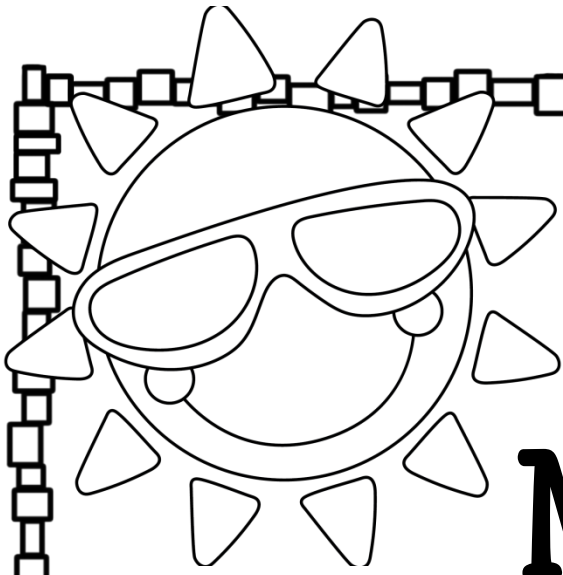

My Math Practice Book

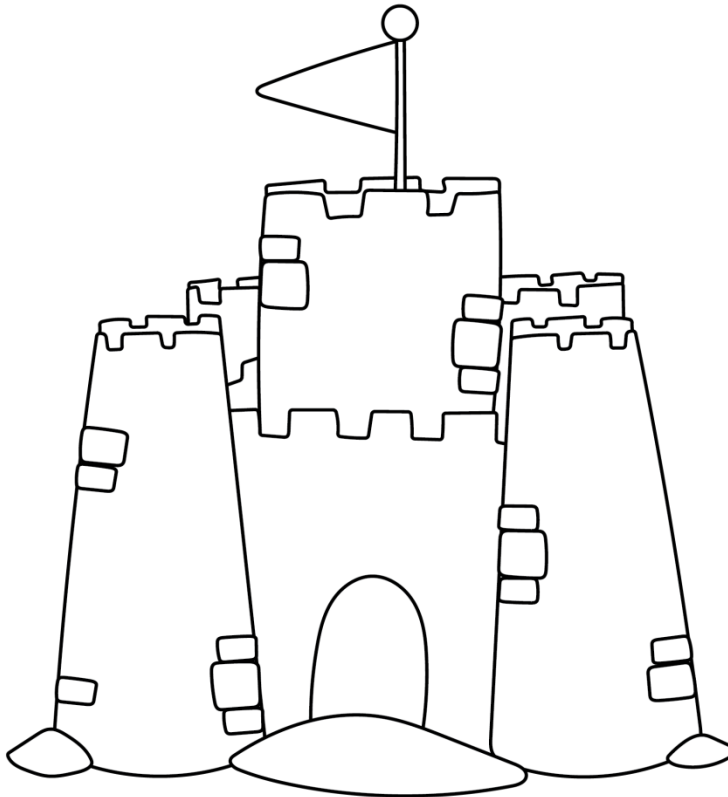
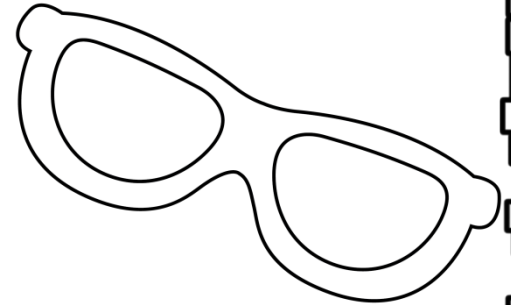

Name: _____

Name: _____

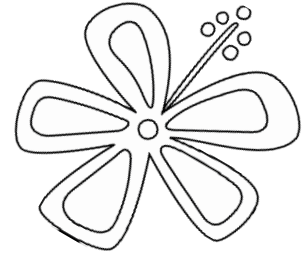

Patterns

Directions: Write the next three numbers and the rule for each pattern.

76, 71, 66, 61, _____, _____, _____

6, 12, 24, 48, _____, _____, _____

98, 97, 95, 92, 88, _____, _____, _____

40, 8, 80, 16, 160, 32, _____, _____, _____

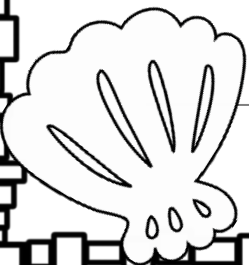

Name: _____

Rounding Numbers

Directions: Round each number to the nearest 100 and then the nearest 1,000.

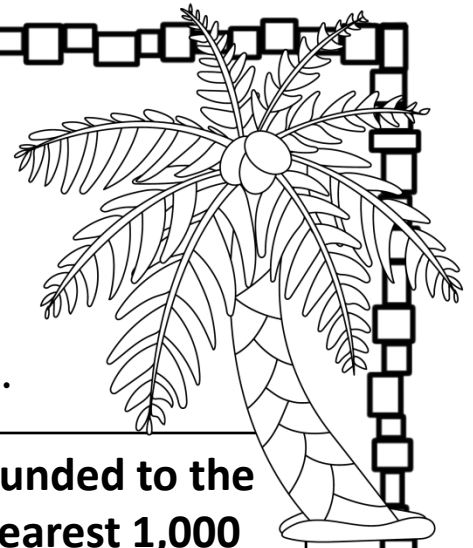

	rounded to the nearest 100	rounded to the nearest 1,000
1,318		
2,323		
6,651		
4,237		
8,938		
3,145		
9,572		
6,863		
7,480		

Name: _____

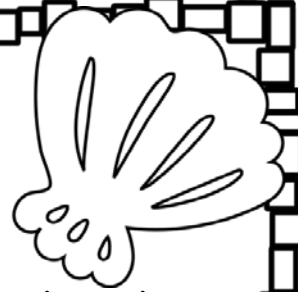

Rounding Practice

Directions: Round to the nearest 1,000 in your head.
If you round up color the sun orange. If you round down color the sun yellow.

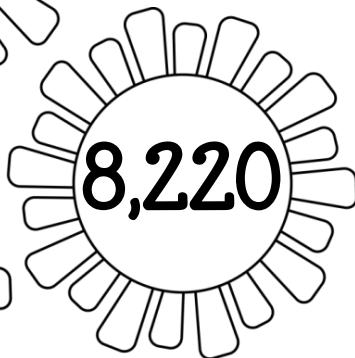
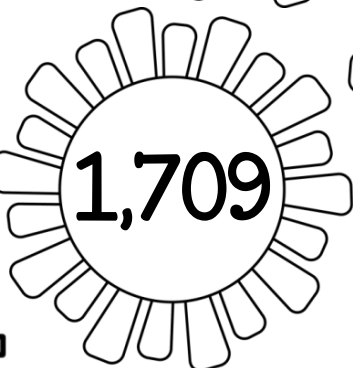
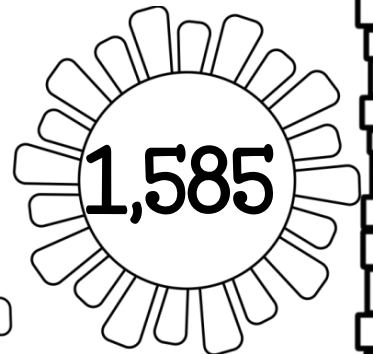
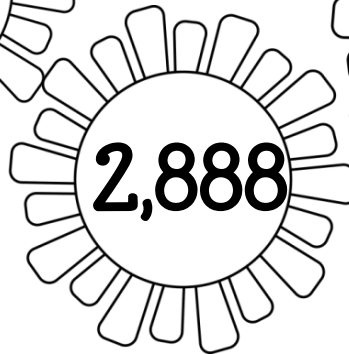
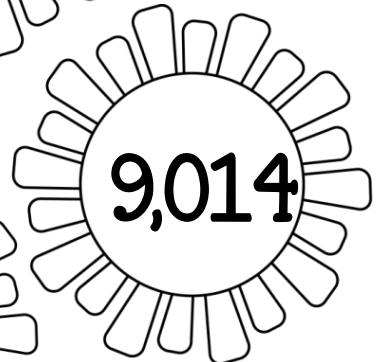
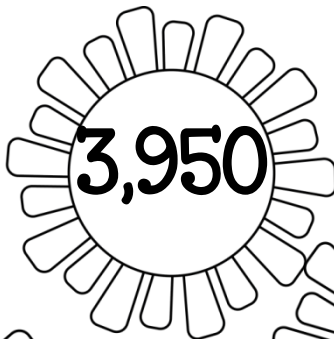
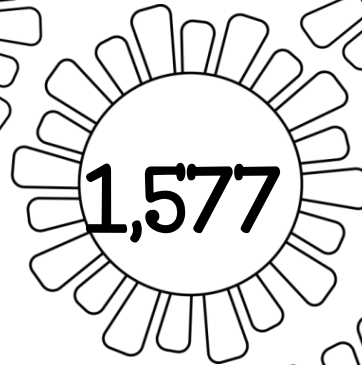
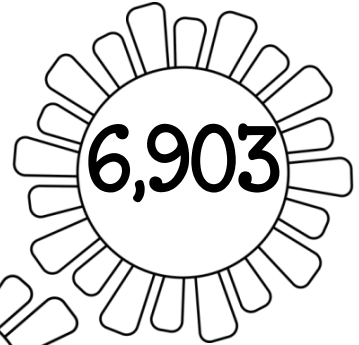
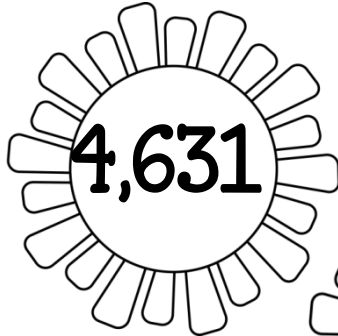
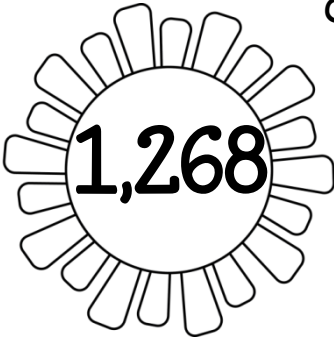

Name: _____

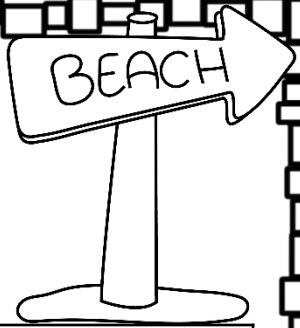

Expanded Form

Directions: Write each number in expanded form.

58	
264	
794	
803	
2,573	
7,180	

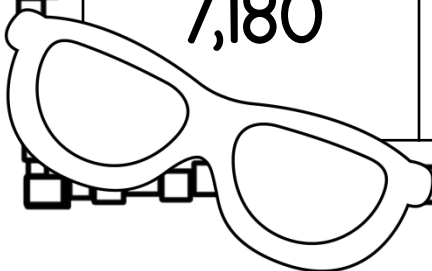



BEACH

Name: _____

Word Form

Directions: Write each number in word form.

71

274

124

507

1,068

6,935

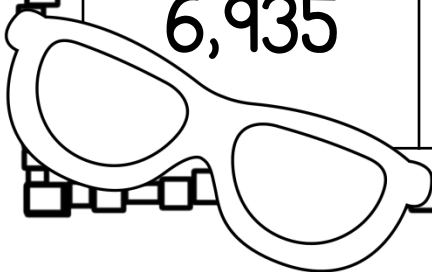

Name: _____

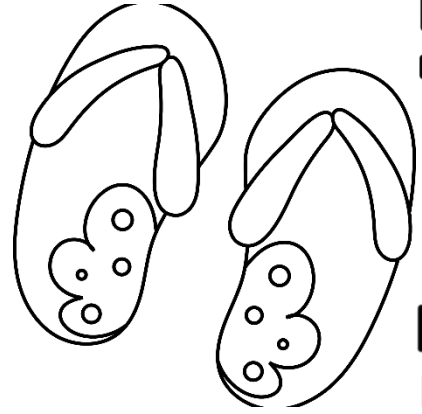

Ordering Numbers

Directions: Write the numbers in order from least to greatest.

3,291 7,295 4,628 5,053

3,879 6,003 3,998 3,446

5,071 1,663 5,611 9,412

5,050 5,005 4,405 4,030

Name: _____

Use $>$, $<$ or $=$

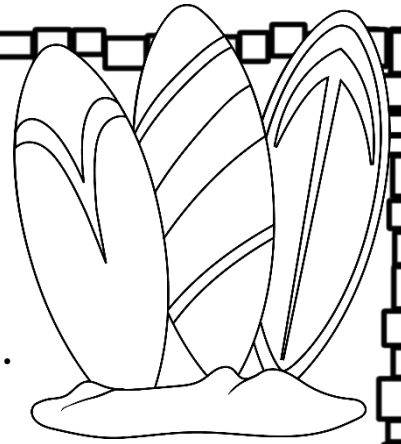

Directions: Compare each set of numbers.
Use the correct sign.

1.20		1.02
------	--	------

5.82		8.52
------	--	------

6.03		6.03
------	--	------

3.07		3.70
------	--	------

4.94		9.94
------	--	------

6.45		4.65
------	--	------

3.75		3.57
------	--	------

1.17		.917
------	--	------

71.2		71.2
------	--	------

2.01		2.00
------	--	------

85.2		80.7
------	--	------

6.77		7.67
------	--	------

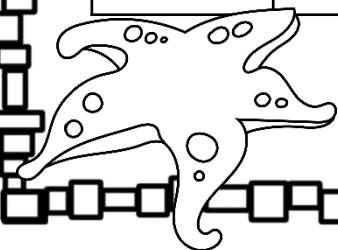

Name: _____

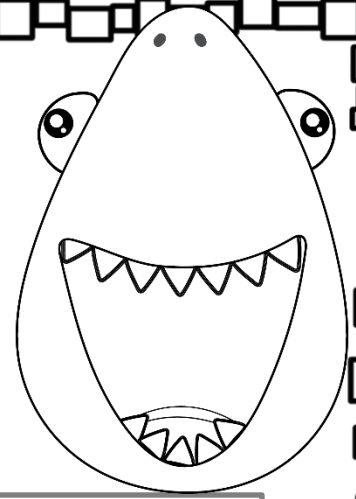

Ordering Decimals

Directions: Write the numbers in order from least to greatest.

1.36, 1.3, 1.63, 1.03

0.3, 0.13, 0.19, 0.31

6.46, 6.41, 4.06, 4.6

0.42, 3.74, 4.2, 3.47

Name: _____

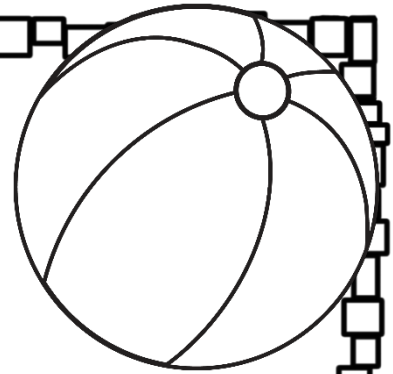

Multiplication & Division

Solving word problems.

Riley has 3 times as many golf balls as Jherica. Jherica has 7 golf balls. How many do they have altogether? Draw a picture to show this. Write the math fact that goes with your picture.

Livy has a coin collection with 24 coins. This is 4 times as many as Kylie has. How many do they have altogether? Draw a picture to show this. Write the math fact that goes with your picture.

Mark has 36 cookies to share with his friends. He is sharing them with 12 friends. How many do they each get? Draw a picture to show this. Write the math fact that goes with your picture.

Name: _____

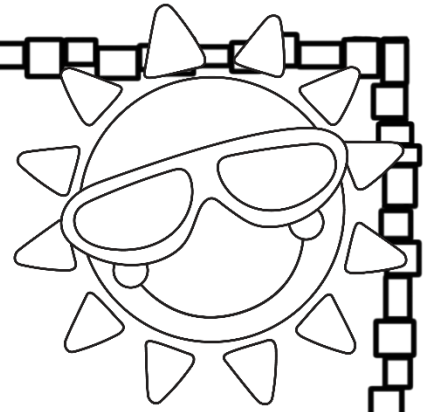

Multi-Step Word Problems

Solving word problems.

Tyla had 24 pieces of drawing paper. Her sister used 2 pages and her brother used 4 pages. She split the rest of the pages with her 2 friends. How many page did each of them get?

Nathan has a bag of candies to share with his friends. There are 34 pieces in the bag. He is going to give an equal number to each of his 5 friends. He will give the rest to his little sister. How many pieces will his sister get?

Lilly had \$10. She spent \$4 on lunch and \$2 on ice cream. Her mom gave her \$3 the next day. How much money does she have now?

Name: _____

Multiples

Directions: List four multiples of each number.

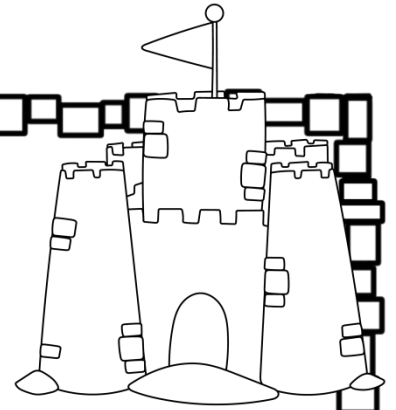

3	6	9	12	15
4				
6				
8				
9				
12				
14				

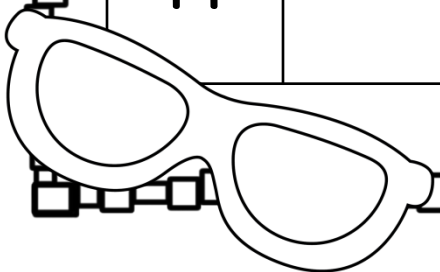

Name: _____

Factors

Directions: Factor each number.

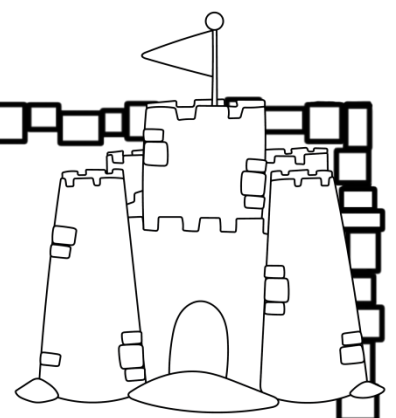

12	1, 2, 3, 4, 6, 12
15	
18	
24	
27	
36	
50	

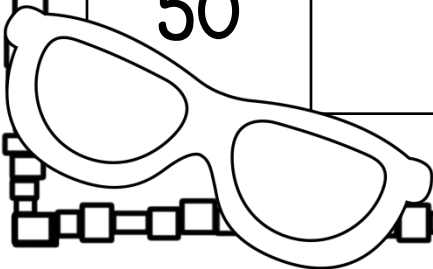

Name: _____

Comparing Numbers

Directions: Write $>$, $<$ or $=$ to compare each pair of numbers.

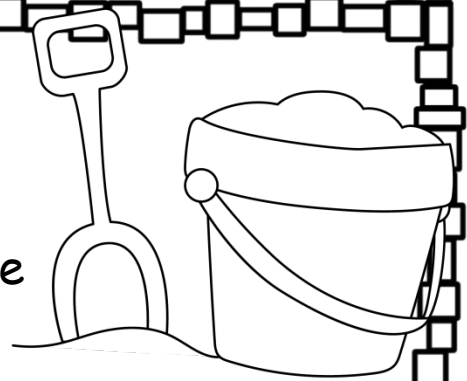

52,000 _____ 52,000

2,641 _____ 1,641

16,083 _____ 15,846

85,276 _____ 83,194

14,410 _____ 14,041

72,053 _____ 72,530

11,104 _____ 11,104

285,582 _____ 285,528

163,091 _____ 160,910

942,850 _____ 952,001

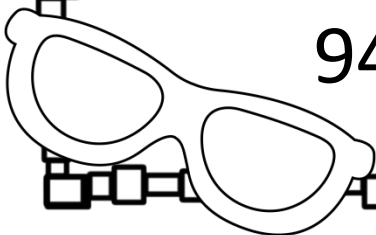

Name: _____

Addition & Subtraction

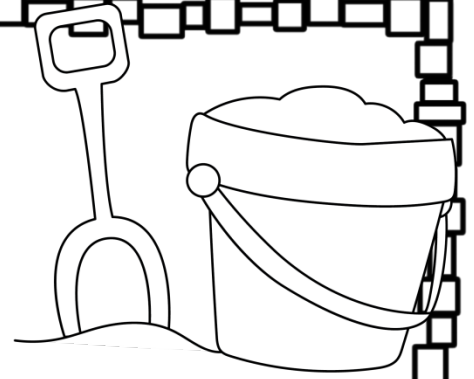

$$\begin{array}{r} 359 \\ +326 \\ \hline \end{array}$$

$$\begin{array}{r} 783 \\ -495 \\ \hline \end{array}$$

$$\begin{array}{r} 524 \\ +509 \\ \hline \end{array}$$

$$\begin{array}{r} 900 \\ -182 \\ \hline \end{array}$$

$$\begin{array}{r} 704 \\ +756 \\ \hline \end{array}$$

$$\begin{array}{r} 930 \\ -672 \\ \hline \end{array}$$

$$\begin{array}{r} 65 \\ 42 \\ +75 \\ \hline \end{array}$$

$$\begin{array}{r} 263 \\ 748 \\ +164 \\ \hline \end{array}$$

$$\begin{array}{r} 683 \\ 842 \\ +275 \\ \hline \end{array}$$

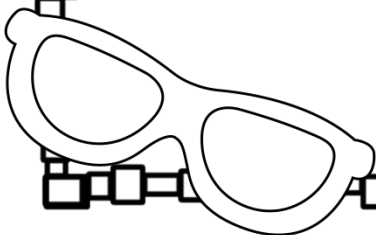

Name: _____

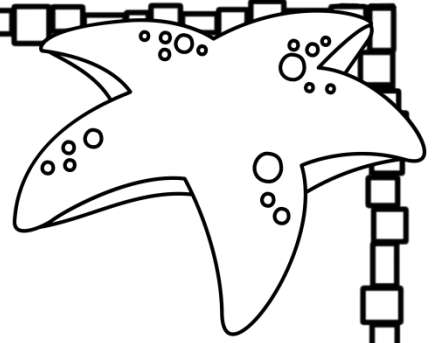

4-Digit Subtraction

$$\begin{array}{r} 8,714 \\ -3,325 \\ \hline \end{array}$$

$$\begin{array}{r} 3,242 \\ -1,489 \\ \hline \end{array}$$

$$\begin{array}{r} 7,263 \\ -5,007 \\ \hline \end{array}$$

$$\begin{array}{r} 6,326 \\ -2,732 \\ \hline \end{array}$$

$$\begin{array}{r} 8,354 \\ -4,829 \\ \hline \end{array}$$

$$\begin{array}{r} 6,901 \\ -6,174 \\ \hline \end{array}$$

$$\begin{array}{r} 9,415 \\ -8,057 \\ \hline \end{array}$$

$$\begin{array}{r} 3,880 \\ -1,882 \\ \hline \end{array}$$

$$\begin{array}{r} 3,000 \\ -1,632 \\ \hline \end{array}$$

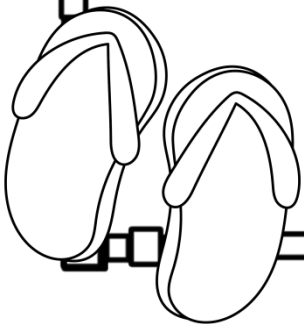

Name: _____

Missing Factors

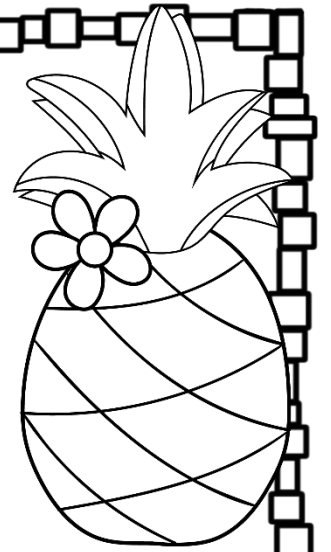

$3 \times \underline{\quad} = 18$

$9 \times \underline{\quad} = 63$

$\underline{\quad} \times 10 = 20$

$5 \times \underline{\quad} = 50$

$\underline{\quad} \times 2 = 18$

$9 \times \underline{\quad} = 90$

$7 \times \underline{\quad} = 49$

$\underline{\quad} \times 8 = 72$

$\underline{\quad} \times 4 = 44$

$4 \times \underline{\quad} = 32$

$6 \times \underline{\quad} = 42$

$\underline{\quad} \times 1 = 9$

$\underline{\quad} \times 8 = 64$

$\underline{\quad} \times 3 = 27$

Name: _____

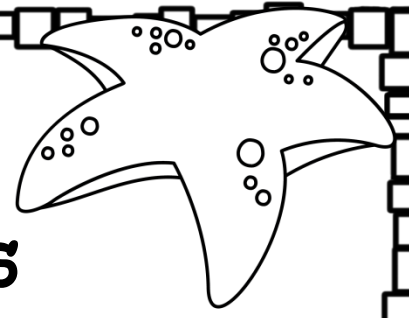

Write the Missing Factors

$6 \times \underline{\quad} = 54$

$3 \times \underline{\quad} = 33$

$\underline{\quad} \times 2 = 16$

$8 \times \underline{\quad} = 32$

$\underline{\quad} \times 4 = 40$

$12 \times \underline{\quad} = 132$

$9 \times \underline{\quad} = 81$

$\underline{\quad} \times 1 = 9$

$\underline{\quad} \times 7 = 21$

$11 \times \underline{\quad} = 110$

$5 \times \underline{\quad} = 35$

$\underline{\quad} \times 10 = 80$

$\underline{\quad} \times 9 = 18$

$\underline{\quad} \times 8 = 88$

Name: _____

Complete the number sentences.

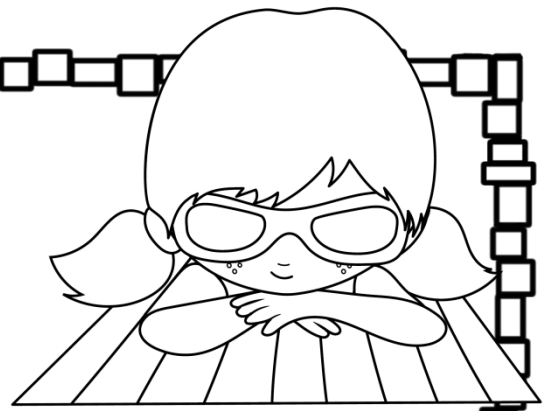

$3 \times \square = 15$

$15 \div 3 = \square$

$8 \times \square = 24$

$24 \div 8 = \square$

$5 \times \square = 45$

$45 \div 5 = \square$

$7 \times \square = 49$

$49 \div 7 = \square$

$12 \times \square = 36$

$36 \div 12 = \square$

$8 \times \square = 64$

$64 \div 8 = \square$

$4 \times \square = 20$

$20 \div 4 = \square$

$9 \times \square = 54$

$54 \div 9 = \square$

$9 \times \square = 99$

$99 \div 9 = \square$

$10 \times \square = 60$

$60 \div 10 = \square$

$9 \times \square = 72$

$72 \div 9 = \square$



Name: _____

Multiplication Practice

Directions: Write the answer to each fact. Color the odd answers red and the even answers blue. You might need to rewrite the problem first.

$27 \times 6 =$

$18 \times 3 =$

$43 \times 9 =$

$39 \times 2 =$

$34 \times 7 =$

$17 \times 6 =$

$18 \times 3 =$

$66 \times 3 =$

$47 \times 4 =$

$52 \times 8 =$

$63 \times 5 =$

$44 \times 9 =$

$27 \times 7 =$

$31 \times 5 =$

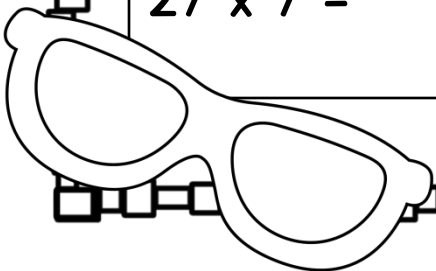

Name: _____

Multiplication Practice

Directions: Write the answer to each fact.
You might need to rewrite the problem first.



$15 \times 26 =$

$24 \times 13 =$

$62 \times 72 =$

$28 \times 67 =$

$92 \times 17 =$

$73 \times 84 =$

$94 \times 35 =$

$28 \times 83 =$

$72 \times 24 =$

$83 \times 18 =$

Name: _____

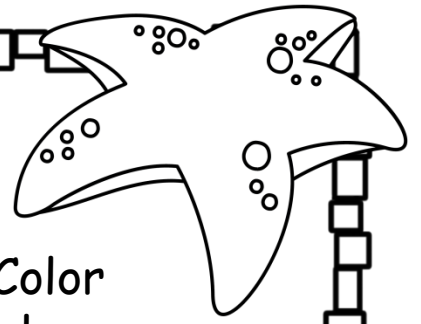

Division Facts

Directions: Write the answer to each fact. Color the odd answers red and the even answers blue.

$40 \div 5 =$

$16 \div 2 =$

$28 \div 7 =$

$36 \div 9 =$

$10 \div 2 =$

$20 \div 4 =$

$18 \div 3 =$

$80 \div 10 =$

$81 \div 9 =$

$6 \div 1 =$

$21 \div 3 =$

$54 \div 6 =$

$45 \div 9 =$

$32 \div 8 =$

$64 \div 8 =$

$24 \div 4 =$

$28 \div 7 =$

$40 \div 4 =$

$42 \div 6 =$

$35 \div 7 =$

$42 \div 7 =$

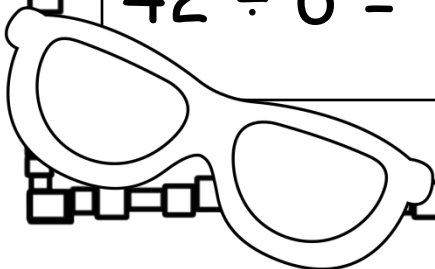

Name: _____

Division Practice

Directions: Write the answer to each fact.
You might need to rewrite the problem first.

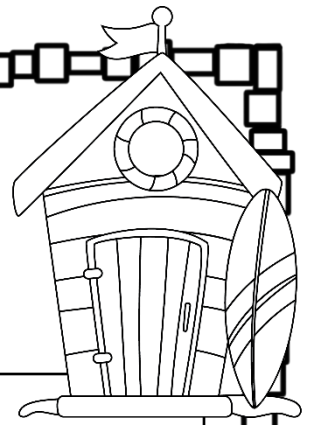

$91 \div 3 =$

$50 \div 3 =$

$43 \div 9 =$

$85 \div 7 =$

$34 \div 7 =$

$79 \div 6 =$

$325 \div 3 =$

$235 \div 5 =$

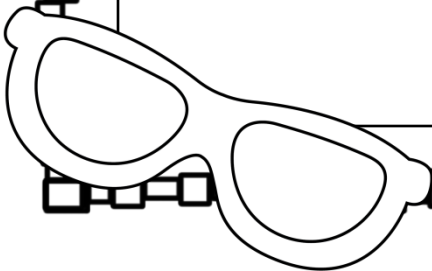

Name: _____

Division Practice

Directions: Write the answer to each problem.
Rewrite the problems first.

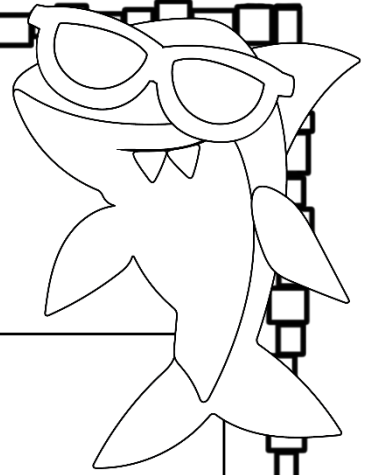

$$8,437 \div 3 =$$

$$2,076 \div 3 =$$

$$8,179 \div 8 =$$

$$4,236 \div 2 =$$

$$9,479 \div 5 =$$

$$6671 \div 2 =$$

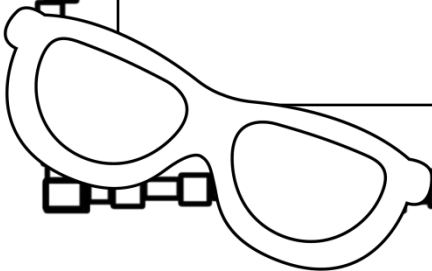

Name: _____

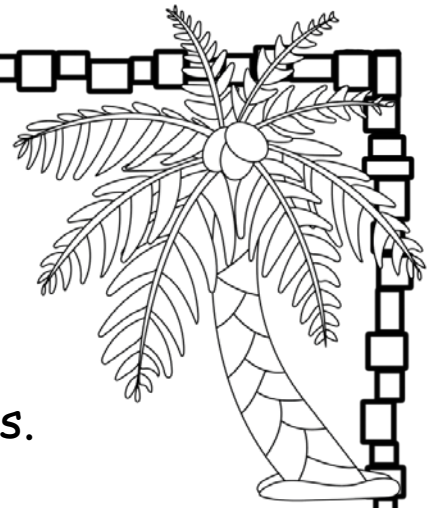

Equivalent Fractions

Directions: Write the equivalent fractions.

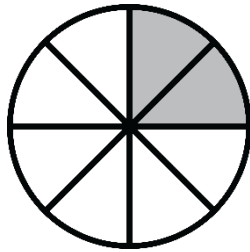
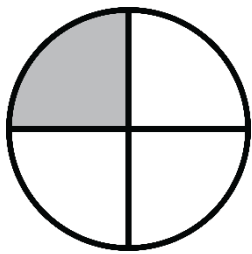

_____ = _____

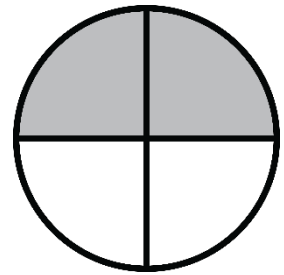
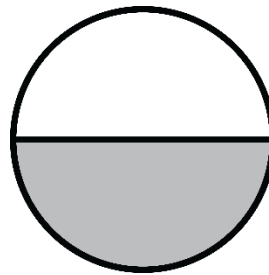

_____ = _____

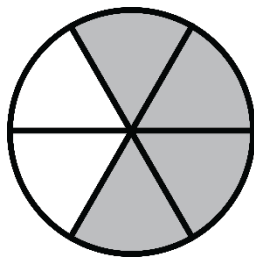
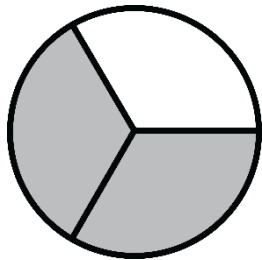

_____ = _____



_____ = _____

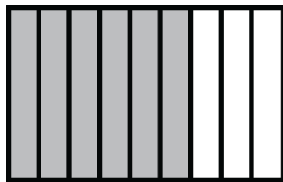

_____ = _____

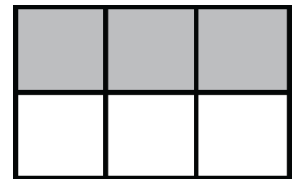
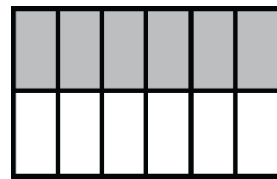

_____ = _____

Name: _____

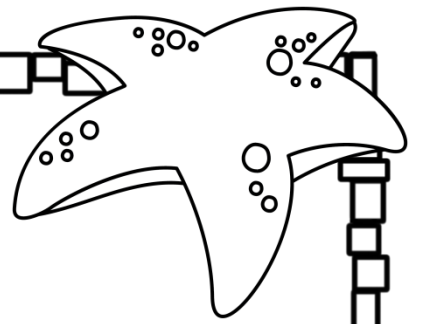

Word Problem Practice

Anya has collected 1,237 seeds to plant in her town's gardens this summer. If there are 9 gardens and she wants to plant the same number of seeds in each garden, how many seeds will she have left?

Thomas collected 3,857 cans of soup to donate to the food pantries in his city. If he wants to give each shelter the same number of cans and there are 8 shelters, how many cans will he have left?

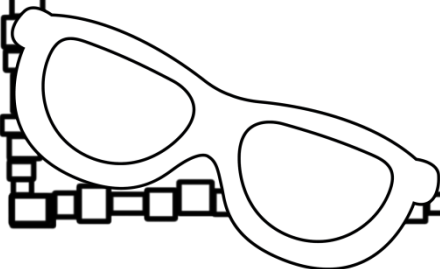

Name: _____

Using Patterns to Divide

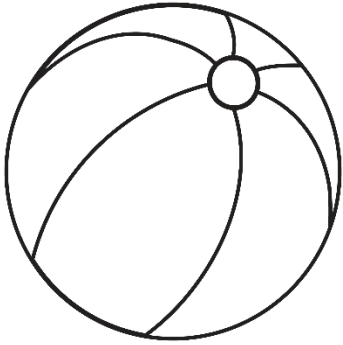

$$210 \div 70 = \underline{\quad}$$

$$140 \div 70 = \underline{\quad}$$

$$1,200 \div 60 = \underline{\quad}$$

$$4,800 \div 80 = \underline{\quad}$$

$$5,000 \div 50 = \underline{\quad}$$

$$6,300 \div 90 = \underline{\quad}$$

$$2,700 \div 30 = \underline{\quad}$$

$$3,500 \div 700 = \underline{\quad}$$

$$4,800 \div 60 = \underline{\quad}$$

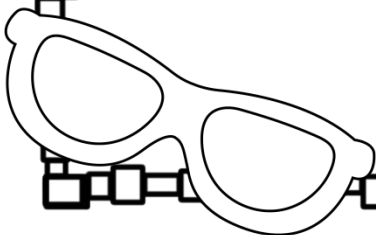
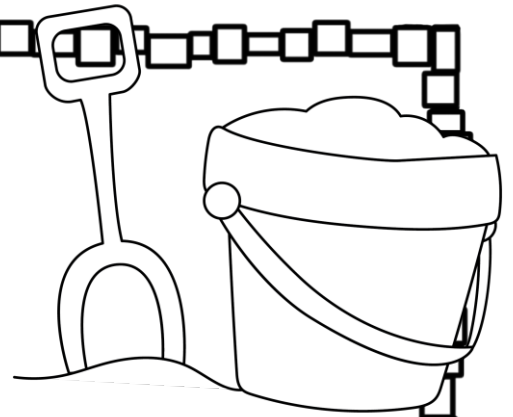

Name: _____

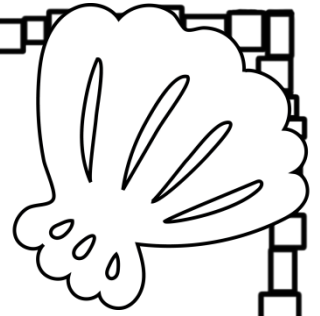

Writing Rules

Directions: Find the missing numbers in each table. Write a rule for each table.

Rule: multiply by _____

input	output
2	18
3	
5	
8	72
9	

Rule: subtract _____

input	output
\$18	\$13
\$22	
\$26	\$20
\$29	
\$35	

Rule: _____

input	output
32	52
38	
47	67
51	71
66	

Rule: _____

input	output
32	64
47	
53	106
68	
172	

Name: _____

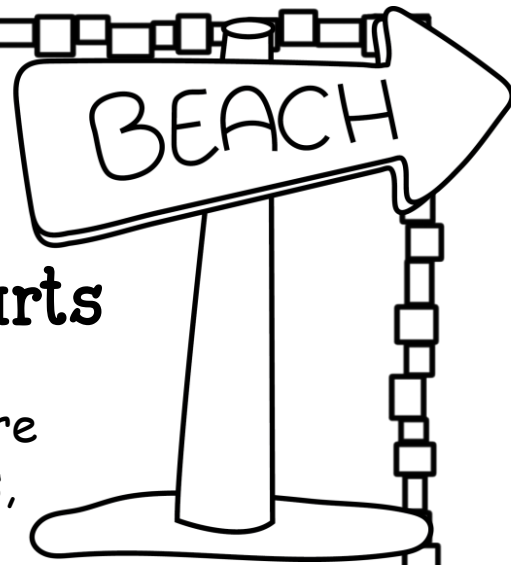

Dividing Shapes into Equal Parts

Directions: Name how the equal parts are divided. (halves, thirds, fourths, fifths, sixths, eighths, ninths)

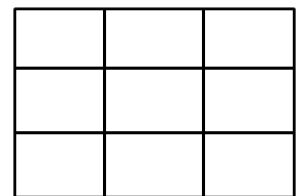
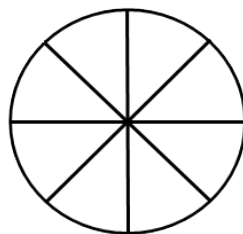
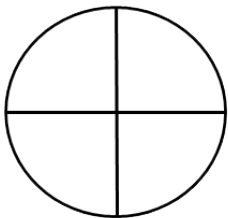
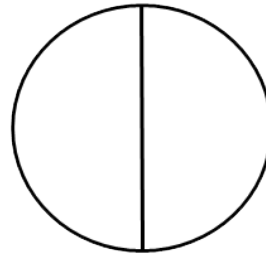
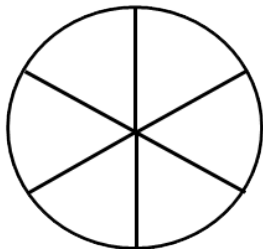
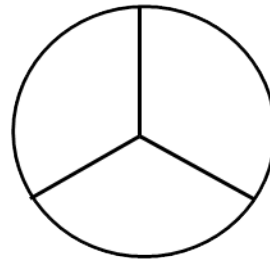
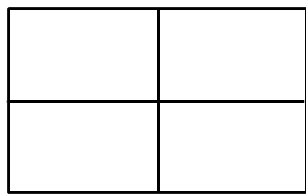

Name: _____

Adding Fractions

Directions: Find the sum.
Simplify the fraction if possible.

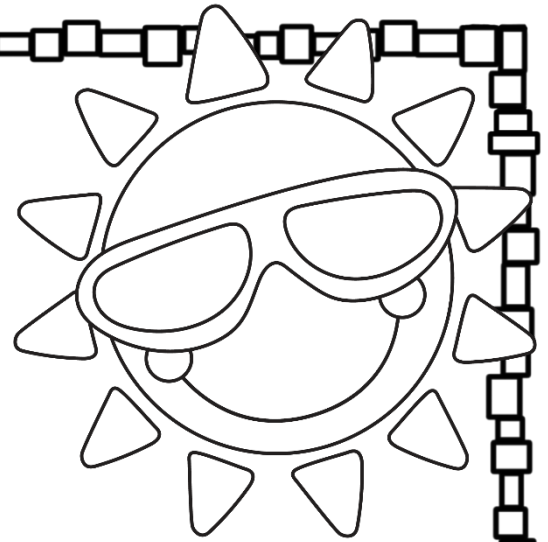

$$\frac{1}{9} + \frac{3}{9} =$$

$$\frac{1}{3} + \frac{1}{3} =$$

$$\frac{1}{4} + \frac{1}{4} =$$

$$\frac{1}{5} + \frac{2}{5} =$$

$$\frac{4}{5} + \frac{1}{5} =$$

$$\frac{3}{6} + \frac{1}{6} =$$

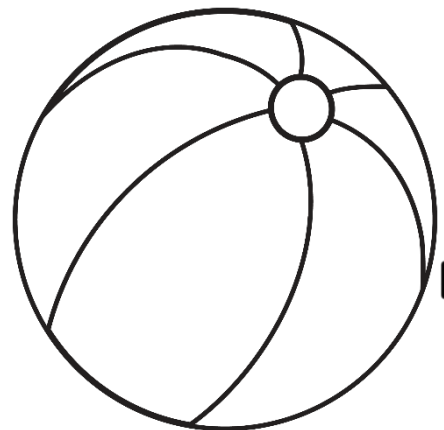

Name: _____

Fractions & Decimals

Directions:

Write each fraction as a decimal.

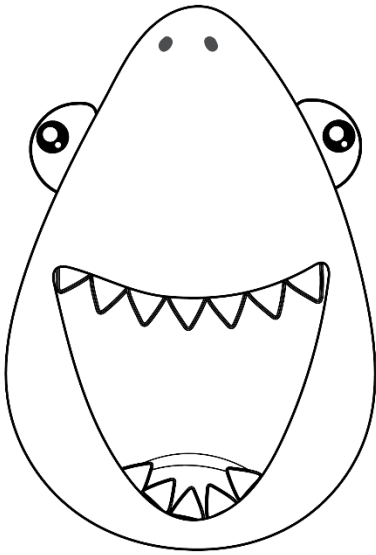
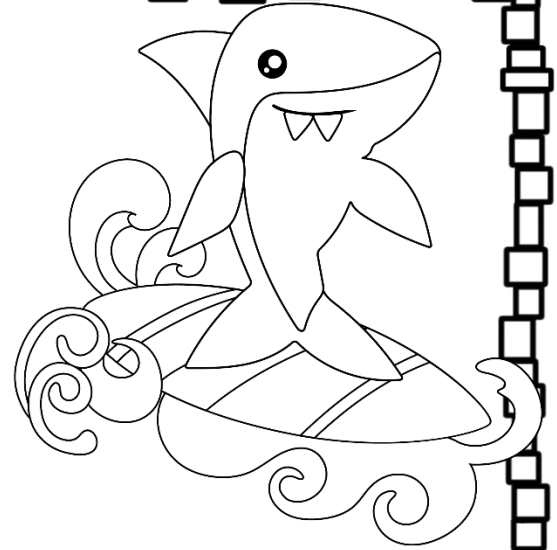

$$\frac{2}{10} =$$

$$\frac{4}{10} =$$

$$\frac{8}{10} =$$

$$\frac{9}{10} =$$

$$\frac{17}{100} =$$

$$6 \frac{30}{100} =$$

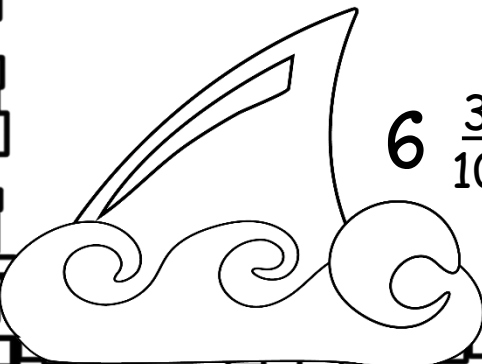
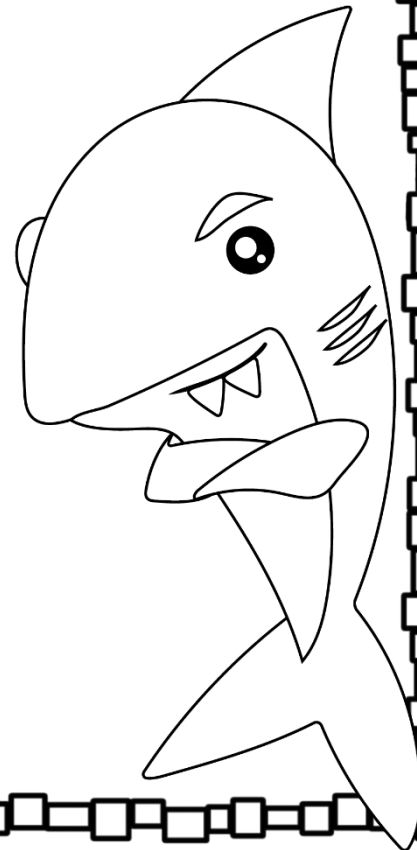

Name: _____

Fractions & Decimals

Directions:

Write each fraction as a decimal.

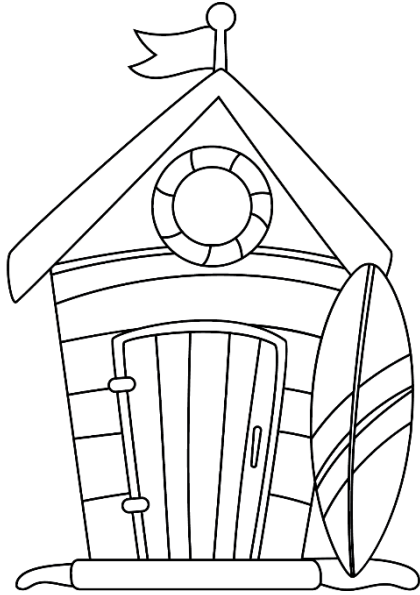
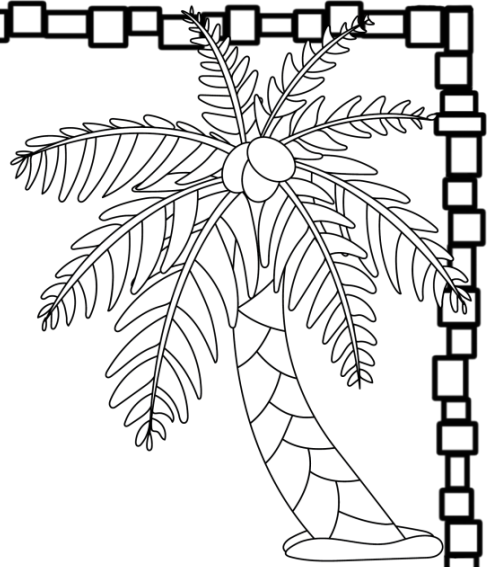

$$\frac{4}{50} =$$

$$\frac{4}{25} =$$

$$\frac{13}{20} =$$

$$\frac{9}{50} =$$

$$\frac{7}{20} =$$

$$\frac{11}{25} =$$

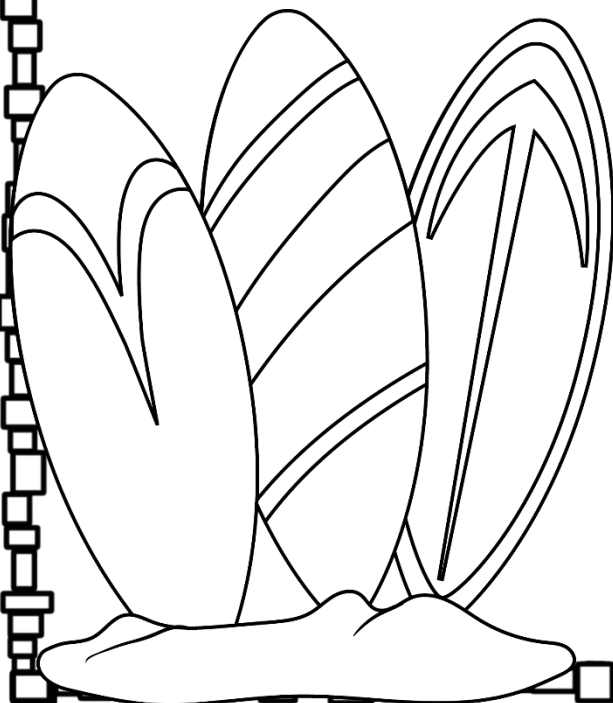

Name: _____

Fractions & Decimals

Directions:

Write each decimal as a fraction in lowest terms.

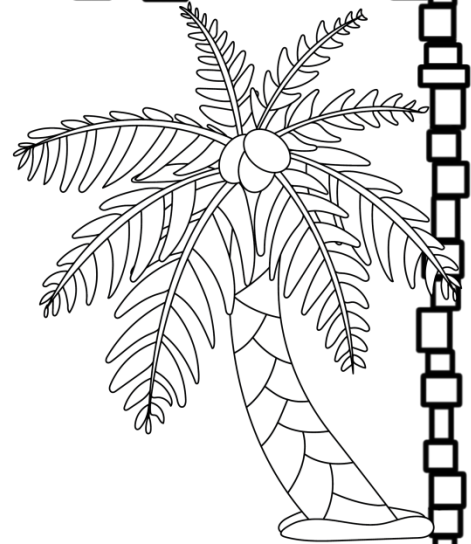

$$6.09 =$$

$$2.41 =$$

$$7.09 =$$

$$41.73 =$$

$$70.37 =$$

$$835.93 =$$

$$264.58 =$$

Name: _____

Money Word Problems

Directions: Find the elapsed time.



Trevor bought a piece of pizza for \$1.75 and a drink for .59. How much did he spend?

Haley bought a bag of popcorn for \$3.15 and a drink for \$1.99. How much did she spend?

Kila bought three movie tickets for her friends. Each ticket was \$8.25. How much did she spend?

Miles had \$20. He bought a movie ticket for \$7.50 and popcorn for \$4.25. How much money does he have left?

Lincoln is going to buy two movie tickets for \$7.50 each. He also wants to buy a drink for \$2.75 and candy for \$2.50. He has \$20. Does he have enough money?

Sylvia spent \$18 at the movies. She bought a ticket for \$7.50 and a drink for \$4.00. She also bought a bag of popcorn. How much did the popcorn cost?

Name: _____

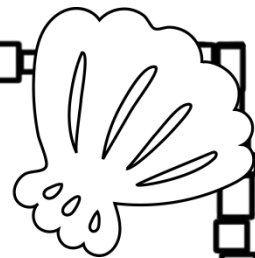

Telling Time Word Problems

Directions: Read and solve each word problem.

It is 6:30. What time will it be in 2 hours and 15 minutes?

It is 3:15. What time will it be in 3 hours and 30 minutes.

It is 1:45. What time will it be in 4 hours and 10 minutes?

It is 8:45. What time was it 2 hours and 30 minutes ago?

It is 10:50. What time was it 4 hours and 10 minutes ago?

It is 5:30. What time was it 3 hours and 20 minutes ago?

Name: _____

Finding the perimeter.

Directions: Add the length of the sides to find the perimeter of each shape.

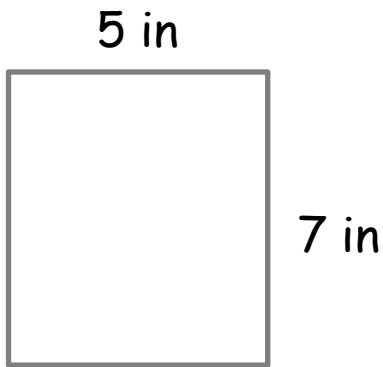
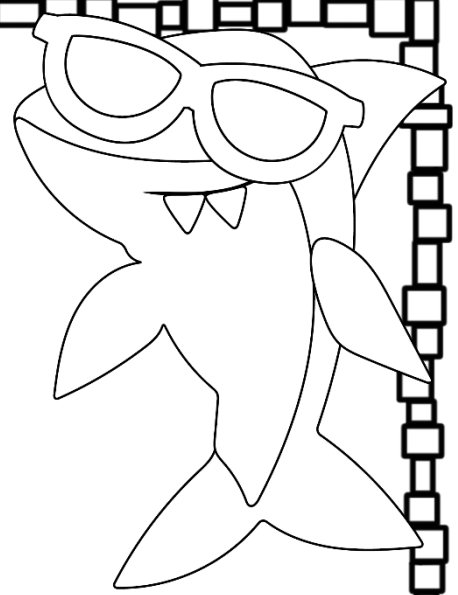

The perimeter is:

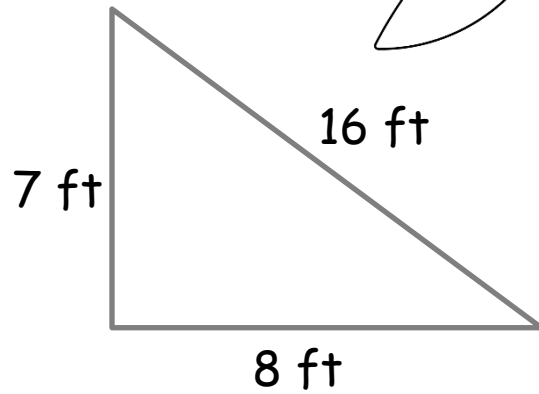

The perimeter is:

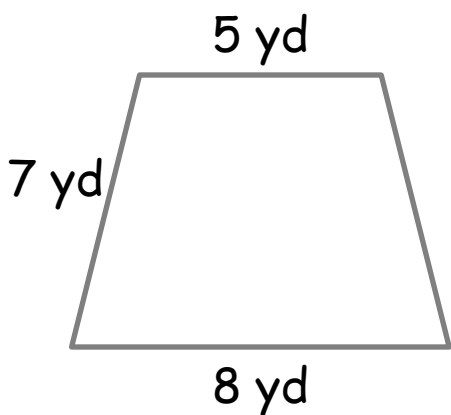

The perimeter is:

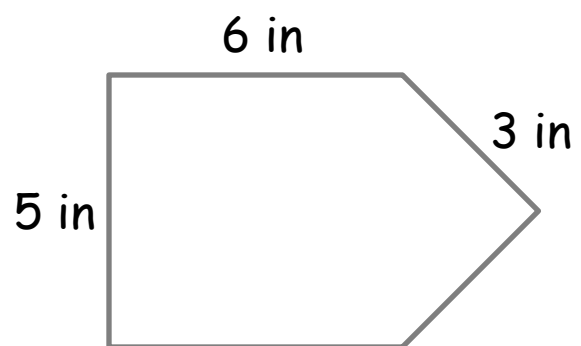

The perimeter is:

Name: _____

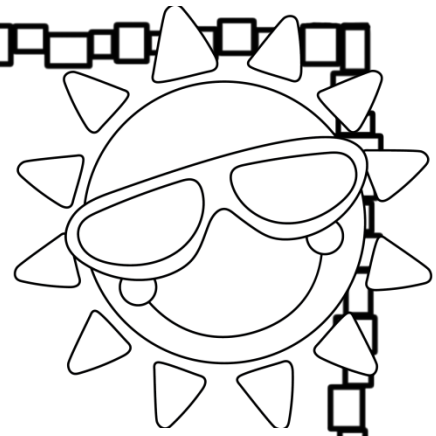

Finding the Area

Directions: Multiply the length by width to find the area.

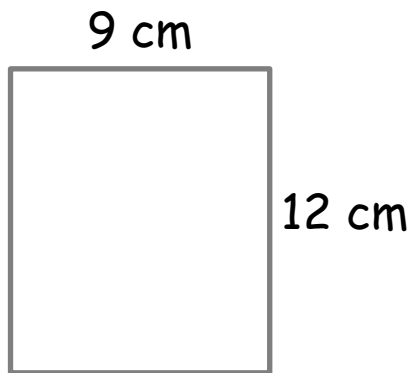

The area is:

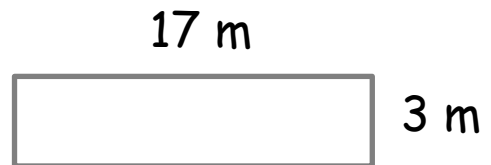

The area is:

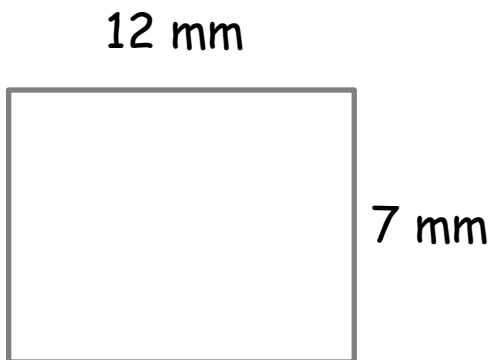

The area is:

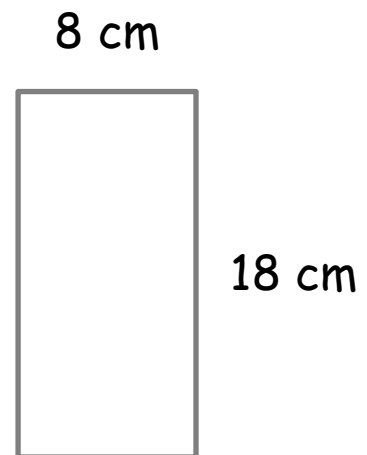

The area is:

Name: _____

Identifying Angles

Directions: Identify each angle below as acute, right or obtuse.

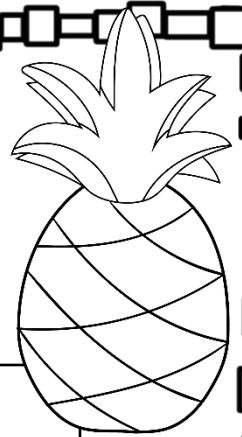

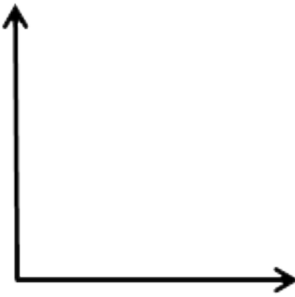
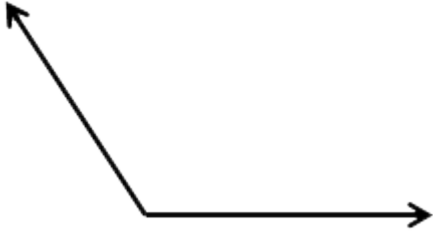
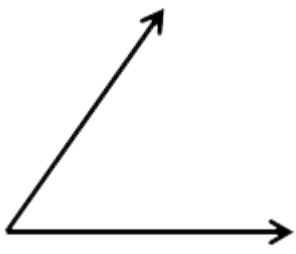
 A right angle (90 degrees) formed by a vertical ray pointing up and a horizontal ray pointing right, meeting at a vertex.	
 An obtuse angle (greater than 90 degrees) formed by a horizontal ray pointing right and another ray pointing up and to the left, meeting at a vertex.	
 An acute angle (less than 90 degrees) formed by a horizontal ray pointing right and another ray pointing up and to the right, meeting at a vertex.	

Name: _____

Label the Triangles

Directions: Label each triangle: equilateral, isosceles or scalene.

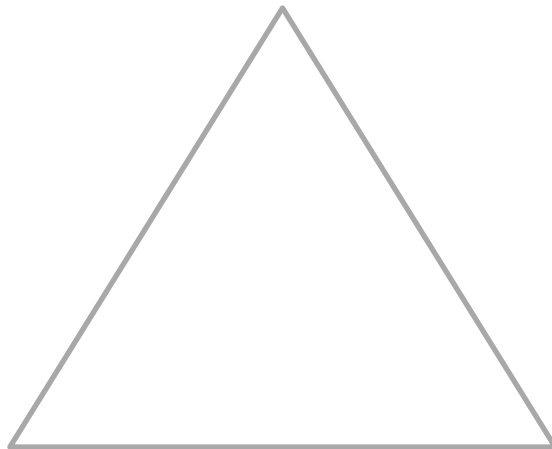
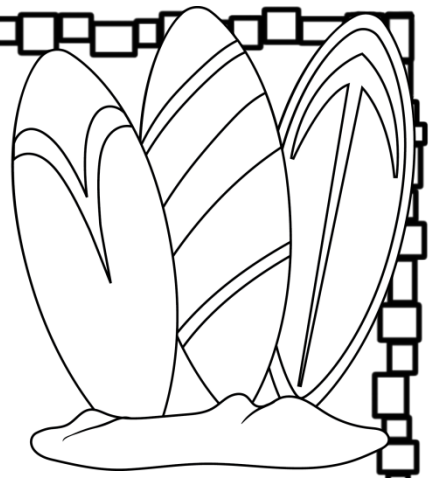

ANSWER KEY

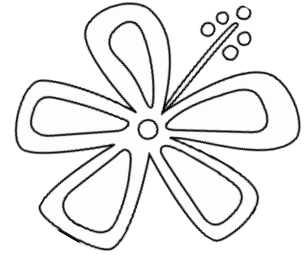

Patterns

Directions: Write the next three numbers and the rule for each pattern.

76, 71, 66, 61, _____, _____, _____

56, 51, 46

6, 12, 24, 48, _____, _____, _____

96, 192, 384

98, 97, 95, 92, 88, _____, _____, _____

83, 77, 70

40, 8, 80, 16, 160, 32, _____, _____, _____

320, 64, 640

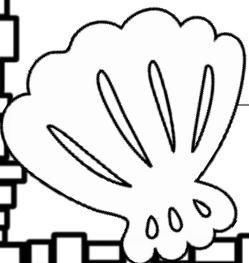

ANSWER KEY

Rounding Numbers

Directions: Round each number to the nearest 100 and then the nearest 1,000.

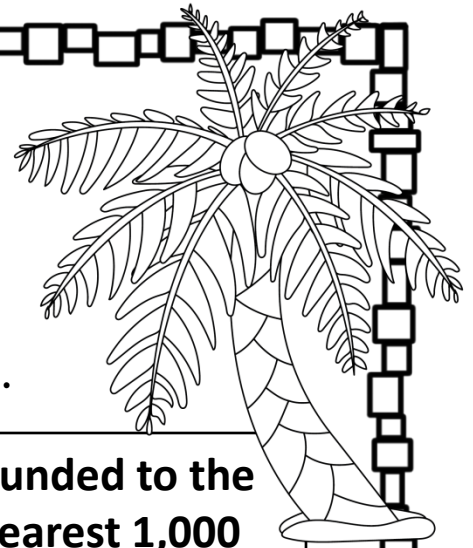

	rounded to the nearest 100	rounded to the nearest 1,000
1,318	1,300	1,000
2,323	2,300	2,000
6,651	6,700	7,000
4,237	4,200	4,000
8,938	8,900	9,000
3,145	3,100	3,000
9,572	9,600	10,000
6,863	6,900	7,000
7,480	7,500	7,000

ANSWER KEY

Rounding Practice

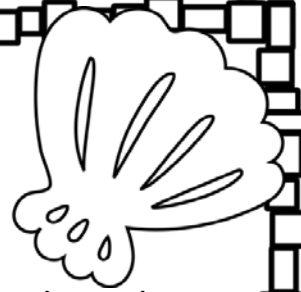

Directions: Round to the nearest 1,000 in your head.
If you round up color the sun orange. If you round down color the sun yellow.

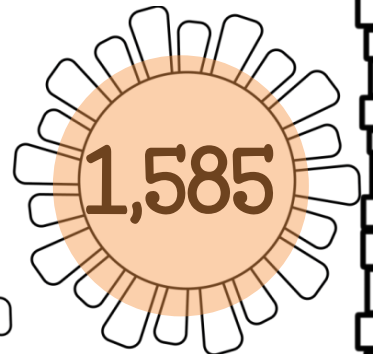
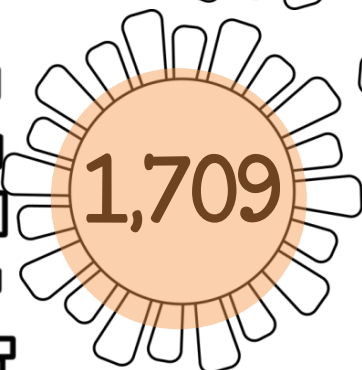
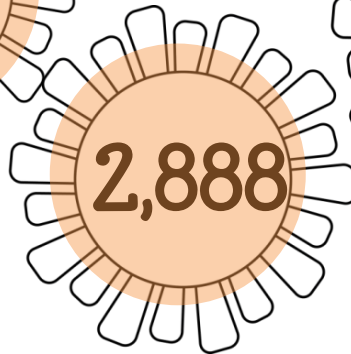
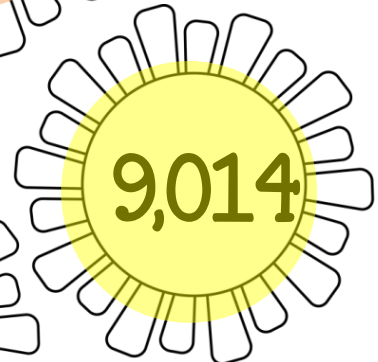
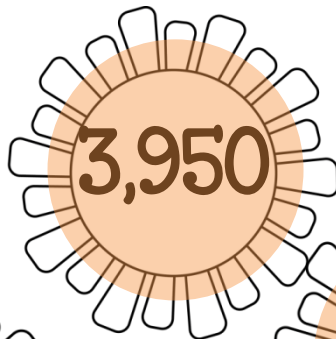
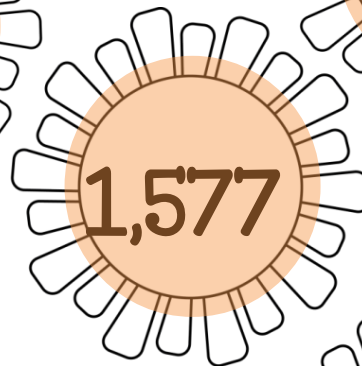
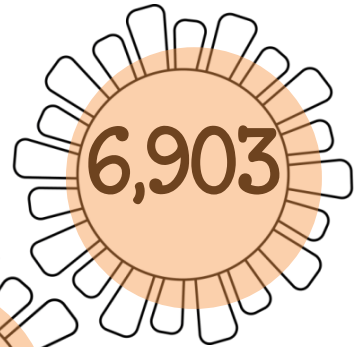
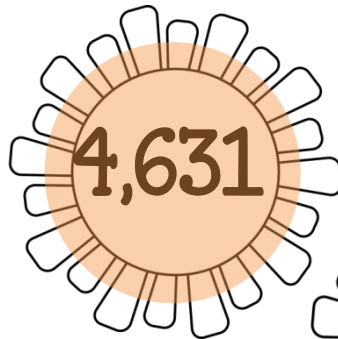
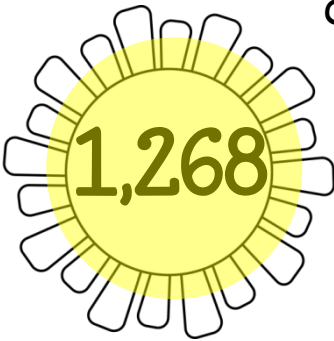

ANSWER KEY



Expanded Form

Directions: Write each number in expanded form.

58	$50 + 8$
264	$200 + 60 + 4$
794	$700 + 90 + 4$
803	$800 + 3$
2,573	$2,000 + 500 + 70 + 3$
7,180	$7,000 + 100 + 80$

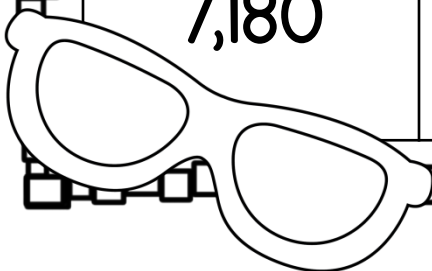

ANSWER KEY



BEACH

Word Form

Directions: Write each number in word form.

71

seventy-one

274

two hundred seventy-four

124

one hundred twenty-four

507

five hundred seven

1,068

one thousand, sixty-eight

6,935

six thousand, nine hundred
thirty-five

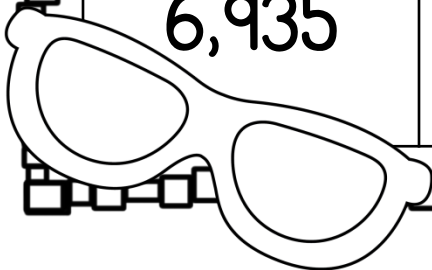

ANSWER KEY

Ordering Numbers

Directions: Write the numbers in order from least to greatest.

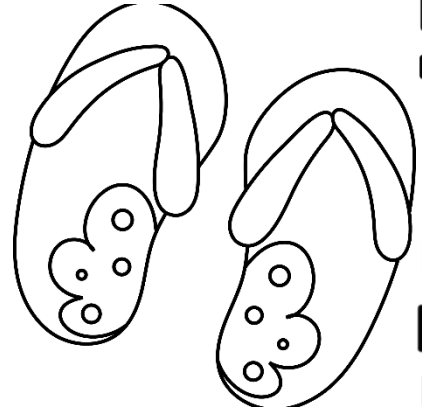

3,291 7,295 4,628 5,053

3,291; 4,628; 5,053; 7,295

3,879 6,003 3,998 3,446

3,446; 3,879; 3,998; 6,003

5,071 1,663 5,611 9,412

1,663; 5,071; 5,611; 9,412

5,050 5,005 4,405 4,030

4,030; 4,405; 5,005; 5,050

ANSWER KEY

Use $>$, $<$ or $=$

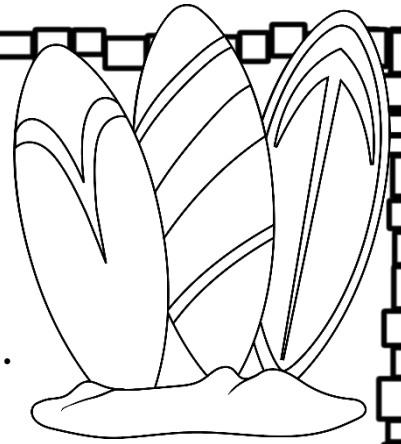

Directions: Compare each set of numbers.
Use the correct sign.

1.20	$>$	1.02
------	-----	------

5.82	$<$	8.52
------	-----	------

6.03	$=$	6.03
------	-----	------

3.07	$<$	3.70
------	-----	------

4.94	$<$	9.94
------	-----	------

6.45	$>$	4.65
------	-----	------

3.75	$>$	3.57
------	-----	------

1.17	$>$.917
------	-----	------

71.2	$=$	71.2
------	-----	------

2.01	$>$	2.00
------	-----	------

85.2	$>$	80.7
------	-----	------

6.77	$<$	7.67
------	-----	------

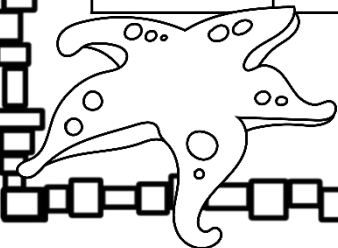

Name: _____

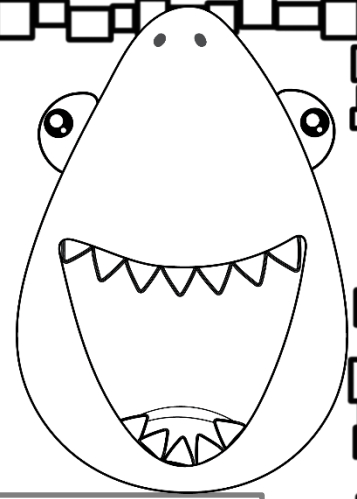

Ordering Decimals

Directions: Write the numbers in order from least to greatest.

1.36, 1.3, 1.63, 1.03

1.03; 1.3; 1.36; 1.63

0.3, 0.13, 0.19, 0.31

0.13; 0.19; 0.3; 0.31

6.46, 6.41, 4.06, 4.6

4.06; 4.6; 6.41; 6.46

0.42, 3.74, 4.2, 3.47

.42; 3.47; 3.74; 4.2

ANSWER KEY

Multiplication & Division

Solving word problems.

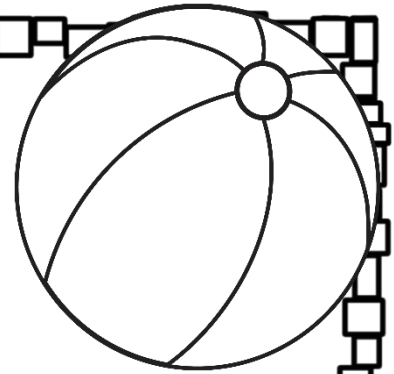

Riley has 3 times as many golf balls as Jherica. Jherica has 7 golf balls. How many do they have altogether? Draw a picture to show this. Write the math fact that goes with your picture.

$$(3 \times 7) + 7 = 28$$

Livy has a coin collection with 24 coins. This is 4 times as many as Kylie has. How many do they have altogether? Draw a picture to show this. Write the math fact that goes with your picture.

$$24 + (24 \div 4) = 30$$

Mark has 36 cookies to share with his friends. He is sharing them with 12 friends. How many do they each get? Draw a picture to show this. Write the math fact that goes with your picture.

$$36 \div 12 = 3$$

ANSWER KEY

Multi-Step Word Problems

Solving word problems.

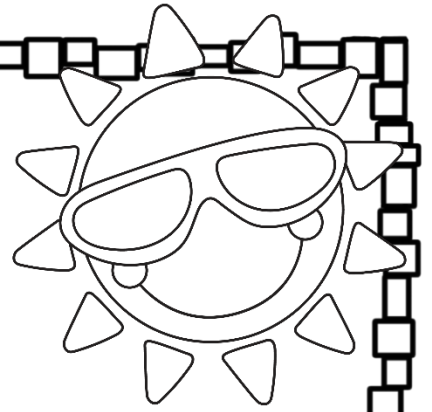

Tyla had 24 pieces of drawing paper. Her sister used 2 pages and her brother used 4 pages. She split the rest of the pages with her 2 friends. How many page did the three of them each get?

6 pieces

Nathan has a bag of candies to share with his friends. There are 34 pieces in the bag. He is going to give an equal number to each of his 5 friends. He will give the rest to his little sister. How many pieces will his sister get?

4 pieces

Lilly had \$10. She spent \$4 on lunch and \$2 on ice cream. Her mom gave her \$3 the next day. How much money does she have now?

\$7

ANSWER KEY

Multiples

Directions: List four multiples of each number.

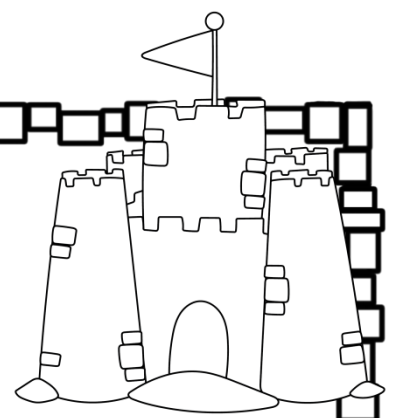

3	6	9	12	15
4	8	12	16	20
6	12	18	24	30
8	16	24	32	40
9	18	27	36	45
12	24	36	48	60
14	28	42	56	70

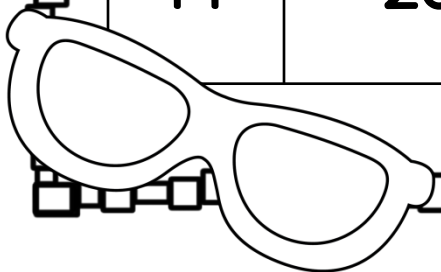

ANSWER KEY

Factors

Directions: Factor each number.

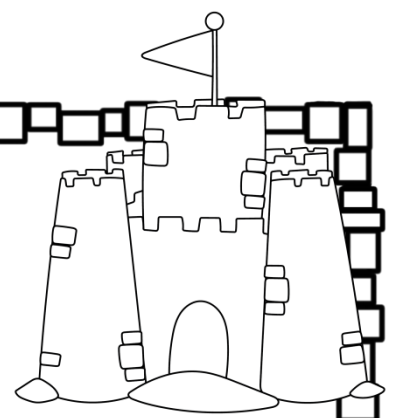

12	1, 2, 3, 4, 6, 12
15	1, 3, 5, 15
18	1, 2, 3, 6, 9, 18
24	1, 2, 3, 4, 6, 8, 12, 24
27	1, 3, 9, 27
36	1, 2, 3, 4, 6, 9, 18, 36
50	1, 2, 5, 10, 25, 50

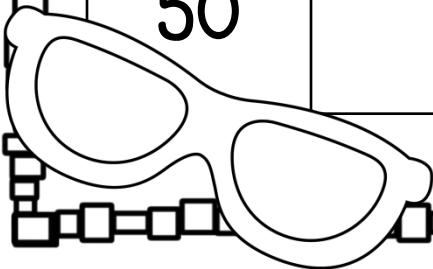

ANSWER KEY

Comparing Numbers

Directions: Write $>$, $<$ or $=$ to compare each pair of numbers.

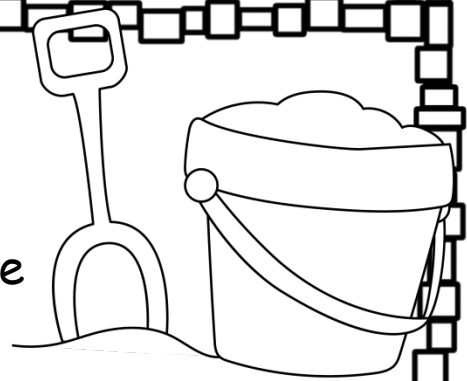

$$52,000 \quad \underline{\quad = \quad} \quad 52,000$$

$$2,641 \quad \underline{\quad > \quad} \quad 1,641$$

$$16,083 \quad \underline{\quad > \quad} \quad 15,846$$

$$85,276 \quad \underline{\quad > \quad} \quad 83,194$$

$$14,410 \quad \underline{\quad > \quad} \quad 14,041$$

$$72,053 \quad \underline{\quad < \quad} \quad 72,530$$

$$11,104 \quad \underline{\quad = \quad} \quad 11,104$$

$$285,582 \quad \underline{\quad > \quad} \quad 285,528$$

$$163,091 \quad \underline{\quad > \quad} \quad 160,910$$

$$942,850 \quad \underline{\quad < \quad} \quad 952,001$$

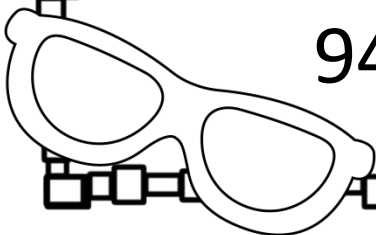

ANSWER KEY

Addition & Subtraction

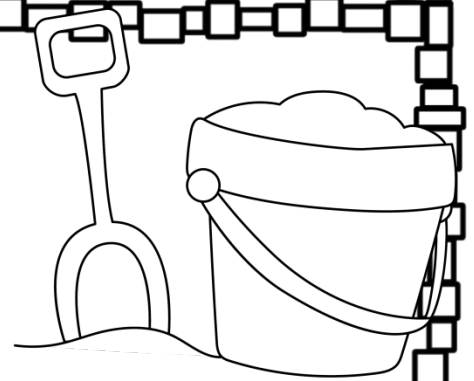

$$\begin{array}{r} 359 \\ +326 \\ \hline 685 \end{array}$$

$$\begin{array}{r} 783 \\ -495 \\ \hline 288 \end{array}$$

$$\begin{array}{r} 524 \\ +509 \\ \hline 1,033 \end{array}$$

$$\begin{array}{r} 900 \\ -182 \\ \hline 718 \end{array}$$

$$\begin{array}{r} 704 \\ +756 \\ \hline 1,460 \end{array}$$

$$\begin{array}{r} 930 \\ -672 \\ \hline 258 \end{array}$$

$$\begin{array}{r} 65 \\ 42 \\ +75 \\ \hline 182 \end{array}$$

$$\begin{array}{r} 263 \\ 748 \\ +164 \\ \hline 1,175 \end{array}$$

$$\begin{array}{r} 683 \\ 842 \\ +275 \\ \hline 1,800 \end{array}$$

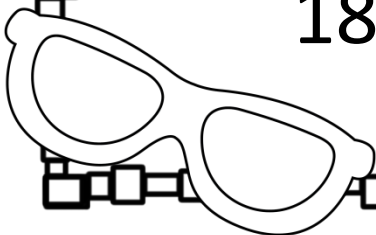

ANSWER KEY

4-Digit Subtraction

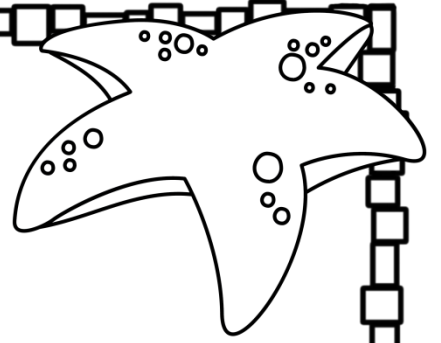

$$\begin{array}{r} 8,714 \\ -3,325 \\ \hline \end{array}$$

$$5,389$$

$$\begin{array}{r} 6,326 \\ -2,732 \\ \hline \end{array}$$

$$3,594$$

$$\begin{array}{r} 9,415 \\ -8,057 \\ \hline \end{array}$$

$$1,358$$

$$\begin{array}{r} 3,242 \\ -1,489 \\ \hline \end{array}$$

$$1,753$$

$$\begin{array}{r} 8,354 \\ -4,829 \\ \hline \end{array}$$

$$3,525$$

$$\begin{array}{r} 3,880 \\ -1,882 \\ \hline \end{array}$$

$$1,998$$

$$\begin{array}{r} 7,263 \\ -5,007 \\ \hline \end{array}$$

$$2,256$$

$$\begin{array}{r} 6,901 \\ -6,174 \\ \hline \end{array}$$

$$727$$

$$\begin{array}{r} 3,000 \\ -1,632 \\ \hline \end{array}$$

$$1,368$$

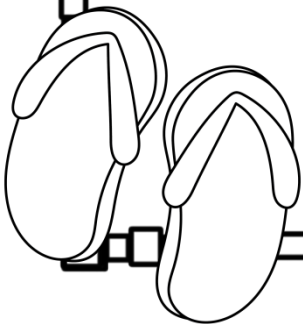

ANSWER KEY

Missing Factors

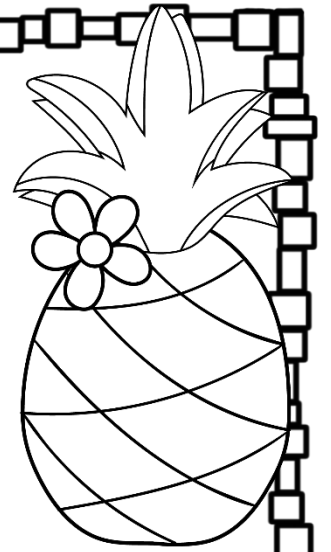

$$3 \times \underline{6} = 18$$

$$9 \times \underline{7} = 63$$

$$\underline{2} \times 10 = 20$$

$$5 \times \underline{10} = 50$$

$$\underline{9} \times 2 = 18$$

$$9 \times \underline{10} = 90$$

$$7 \times \underline{7} = 49$$

$$\underline{9} \times 8 = 72$$

$$\underline{11} \times 4 = 44$$

$$4 \times \underline{8} = 32$$

$$6 \times \underline{7} = 42$$

$$\underline{9} \times 1 = 9$$

$$\underline{8} \times 8 = 64$$

$$\underline{9} \times 3 = 27$$

ANSWER KEY

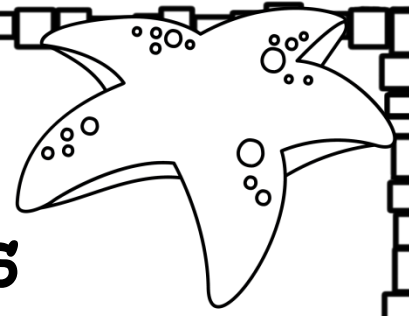

Write the Missing Factors

$$6 \times \underline{9} = 54$$

$$3 \times \underline{11} = 33$$

$$\underline{8} \times 2 = 16$$

$$8 \times \underline{4} = 32$$

$$\underline{10} \times 4 = 40$$

$$12 \times \underline{11} = 132$$

$$9 \times \underline{9} = 81$$

$$\underline{9} \times 1 = 9$$

$$\underline{3} \times 7 = 21$$

$$11 \times \underline{10} = 110$$

$$5 \times \underline{7} = 35$$

$$\underline{8} \times 10 = 80$$

$$\underline{2} \times 9 = 18$$

$$\underline{11} \times 8 = 88$$

ANSWER KEY

Complete the number sentences.

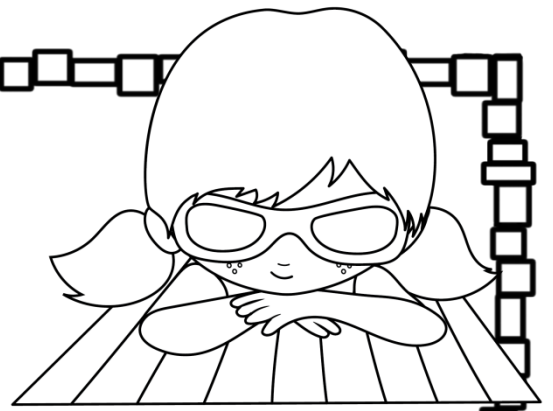

$3 \times 5 = 15$

$15 \div 3 = 5$

$8 \times 3 = 24$

$24 \div 8 = 3$

$5 \times 9 = 45$

$45 \div 5 = 9$

$7 \times 7 = 49$

$49 \div 7 = 7$

$12 \times 3 = 36$

$36 \div 12 = 3$

$8 \times 8 = 64$

$64 \div 8 = 8$

$4 \times 5 = 20$

$20 \div 4 = 5$

$9 \times 6 = 54$

$54 \div 9 = 6$

$9 \times 11 = 99$

$99 \div 9 = 11$

$10 \times 6 = 60$

$60 \div 10 = 6$

$9 \times 8 = 72$

$72 \div 9 = 8$

ANSWER KEY

Multiplication Practice

Directions: Write the answer to each fact. Color the odd answers red and the even answers blue. You might need to rewrite the problem first.

$27 \times 6 = 162$

$18 \times 3 = 54$

$43 \times 9 = 387$

$39 \times 2 = 78$

$34 \times 7 = 238$

$17 \times 6 = 102$

$18 \times 3 = 54$

$66 \times 3 = 198$

$47 \times 4 = 188$

$52 \times 8 = 416$

$63 \times 5 = 5,080$

$44 \times 9 = 396$

$27 \times 7 = 168$

$31 \times 5 = 155$

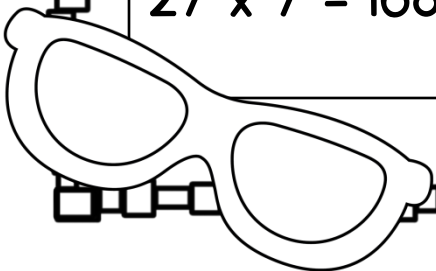

ANSWER KEY

Multiplication Practice

Directions: Write the answer to each fact.
You might need to rewrite the problem first.



$15 \times 26 = 390$

$24 \times 13 = 312$

$62 \times 72 = 4,896$

$28 \times 67 = 1,876$

$92 \times 17 = 1,564$

$73 \times 84 = 6,132$

$94 \times 35 = 3,290$

$28 \times 83 = 2,324$

$72 \times 24 = 1,728$

$83 \times 18 = 1,494$

ANSWER KEY

Division Facts

Directions: Write the answer to each fact. Color the odd answers red and the even answers blue.

$40 \div 5 = 8$

$16 \div 2 = 8$

$28 \div 7 = 4$

$36 \div 9 = 4$

$10 \div 2 = 5$

$20 \div 4 = 5$

$18 \div 3 = 6$

$80 \div 10 = 8$

$81 \div 9 = 9$

$6 \div 1 = 6$

$21 \div 3 = 7$

$54 \div 6 = 9$

$45 \div 9 = 5$

$32 \div 8 = 4$

$64 \div 8 = 8$

$24 \div 4 = 6$

$28 \div 7 = 4$

$40 \div 4 = 10$

$42 \div 6 = 7$

$35 \div 7 = 5$

$42 \div 7 = 6$

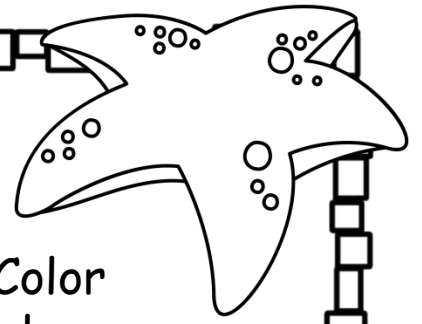

ANSWER KEY

Division Practice

Directions: Write the answer to each fact.
You might need to rewrite the problem first.

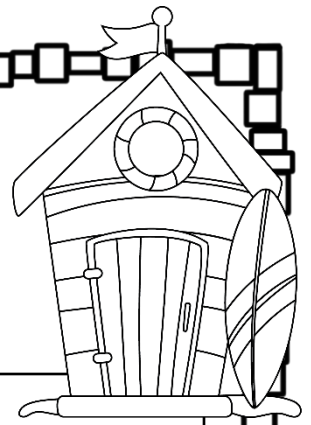

$91 \div 3 =$

$30 \frac{1}{3}$

$50 \div 3 =$

$16 \frac{2}{3}$

$43 \div 9 =$

$4 \frac{7}{9}$

$85 \div 7 =$

$12 \frac{1}{7}$

$34 \div 7 =$

$4 \frac{6}{7}$

$79 \div 6 =$

$16 \frac{2}{3}$

$325 \div 3 =$

$108 \frac{1}{3}$

$235 \div 5 =$

47

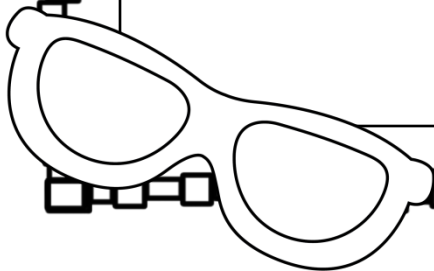

ANSWER KEY

Division Practice

Directions: Write the answer to each problem.
Rewrite the problems first.

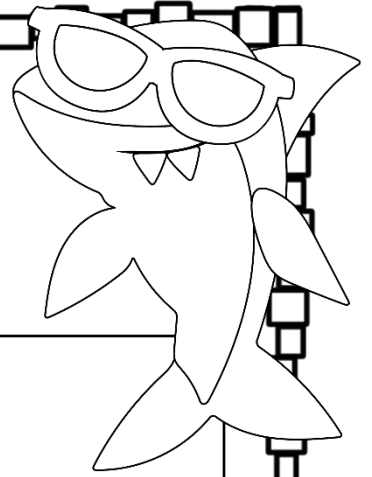

$$8,437 \div 3 =$$

$$2,812 \frac{1}{3}$$

$$2,076 \div 3 =$$

$$692$$

$$8,179 \div 8 =$$

$$1,022 \frac{3}{8}$$

$$4,236 \div 2 =$$

$$2,118$$

$$9,479 \div 5 =$$

$$1,895 \frac{1}{5}$$

$$6671 \div 2 =$$

$$3,335 \frac{1}{2}$$

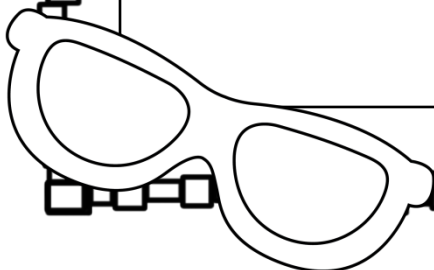

ANSWER KEY

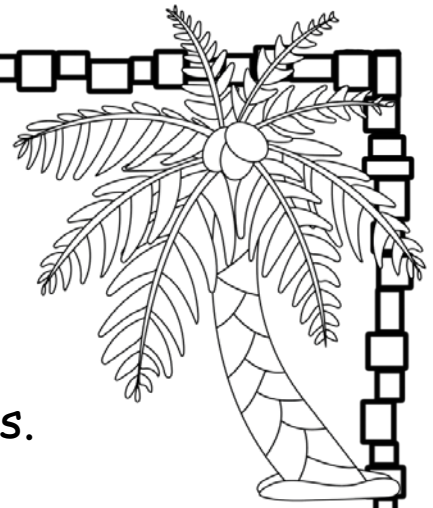

Equivalent Fractions

Directions: Write the equivalent fractions.

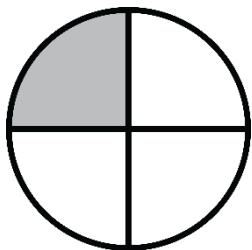

$$\frac{1}{4}$$

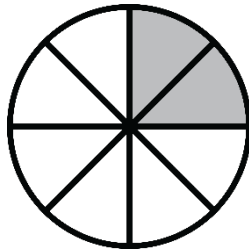

$$\frac{2}{8}$$

$$\underline{\quad \frac{1}{4} \quad} = \underline{\quad \frac{2}{8} \quad}$$

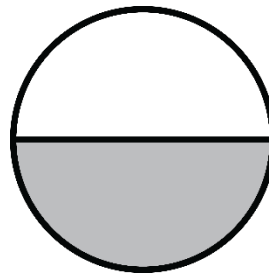

$$\frac{1}{4}$$

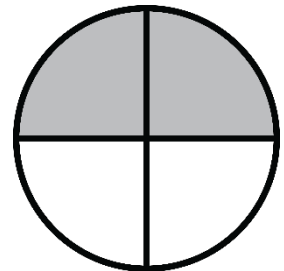

$$\frac{2}{8}$$

$$\underline{\quad \frac{1}{4} \quad} = \underline{\quad \frac{2}{8} \quad}$$

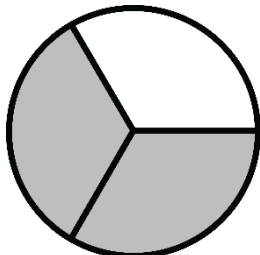

$$\frac{2}{3}$$

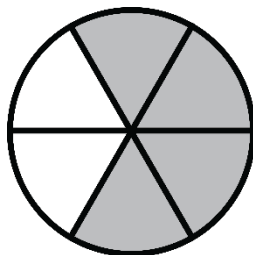

$$\frac{4}{6}$$

$$\underline{\quad \frac{2}{3} \quad} = \underline{\quad \frac{4}{6} \quad}$$



$$\frac{2}{8}$$



$$\frac{1}{4}$$

$$\underline{\quad \frac{2}{8} \quad} = \underline{\quad \frac{1}{4} \quad}$$



$$\frac{2}{3}$$

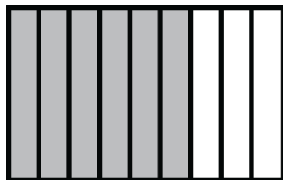

$$\frac{6}{9}$$

$$\underline{\quad \frac{2}{3} \quad} = \underline{\quad \frac{6}{9} \quad}$$

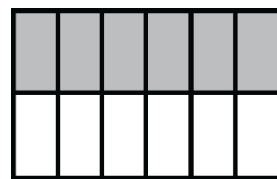

$$\frac{6}{12}$$

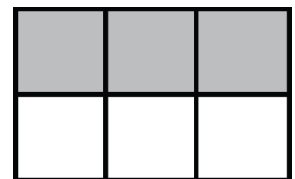

$$\frac{3}{6}$$

$$\underline{\quad \frac{6}{12} \quad} = \underline{\quad \frac{3}{6} \quad}$$



ANSWER KEY

Word Problem Practice

Anya has collected 1,237 seeds to plant in her town's gardens this summer. If there are 9 gardens and she wants to plant the same number of seeds in each garden, how many seeds will she have left?

4 seeds

Thomas collected 3,857 cans of soup to donate to the food pantries in his city. If he wants to give each shelter the same number of cans and there are 8 shelters, how many cans will he have left?

1 can

ANSWER KEY

Using Patterns to Divide

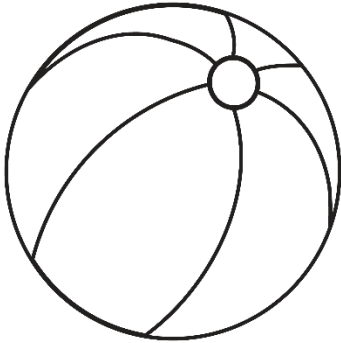

$$210 \div 70 = \underline{3}$$

$$140 \div 70 = \underline{2}$$

$$1,200 \div 60 = \underline{80}$$

$$4,800 \div 80 = \underline{60}$$

$$5,000 \div 50 = \underline{500}$$

$$6,300 \div 90 = \underline{70}$$

$$2,700 \div 30 = \underline{90}$$

$$3,500 \div 700 = \underline{5}$$

$$4,800 \div 60 = \underline{80}$$

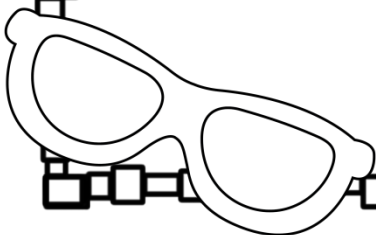
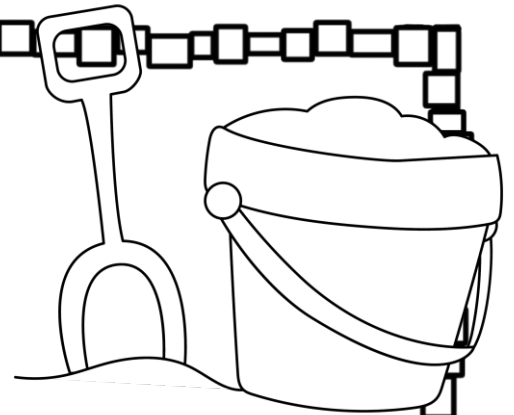

ANSWER KEY

Writing Rules

Directions: Find the missing numbers in each table. Write a rule for each table.

Rule: multiply by 9

input	output
2	18
3	27
5	45
8	72
9	81

Rule: subtract 5

input	output
\$18	\$13
\$22	\$110
\$26	\$20
\$29	\$145
\$35	\$175

Rule: +20

input	output
32	52
38	58
47	67
51	71
66	86

Rule: x2

input	output
32	64
47	94
53	106
68	136
172	344

ANSWER KEY

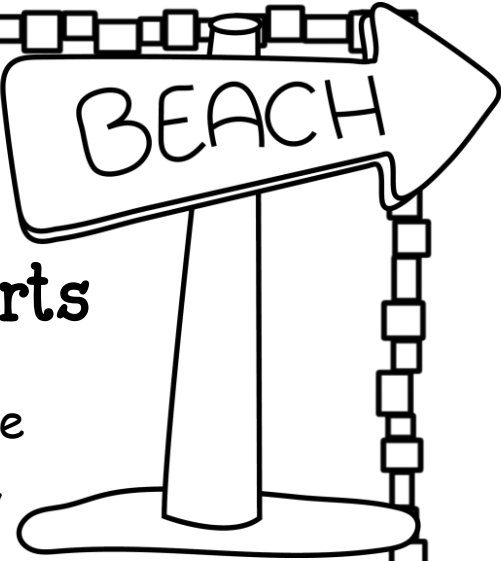

Dividing Shapes into Equal Parts

Directions: Name how the equal parts are divided. (halves, thirds, fourths, fifths, sixths, eighths, ninths)



fourths



thirds

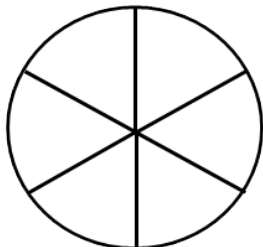

sixths

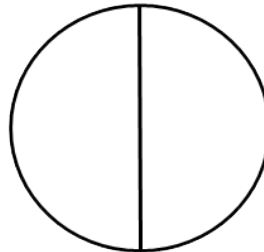

halves

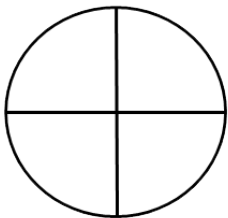

fourths

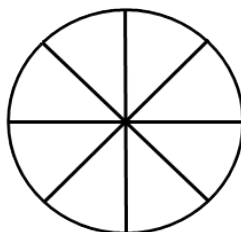

eighths

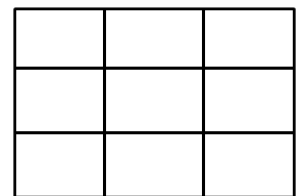

ninths

ANSWER KEY

Adding Fractions

Directions: Find the sum.
Simplify the fraction if possible.

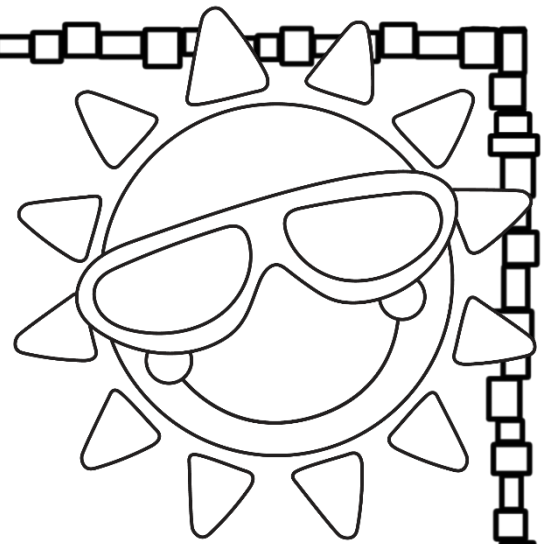

$$\frac{1}{9} + \frac{3}{9} = \frac{4}{9}$$

$$\frac{1}{3} + \frac{1}{3} = \frac{2}{3}$$

$$\frac{1}{4} + \frac{1}{4} = \frac{2}{8} = \frac{1}{4}$$

$$\frac{1}{5} + \frac{2}{5} = \frac{3}{5}$$

$$\frac{4}{5} + \frac{1}{5} = \frac{5}{5} = 1$$

$$\frac{3}{6} + \frac{1}{6} = \frac{4}{6} = \frac{2}{3}$$

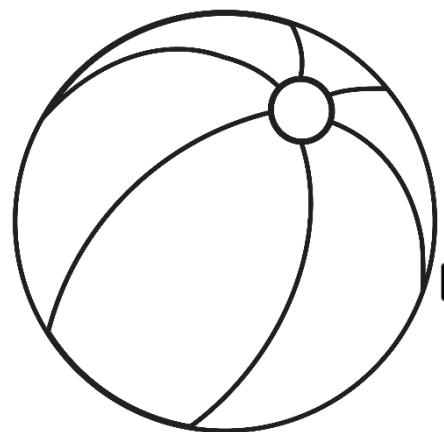

ANSWER KEY

Fractions & Decimals

Directions:

Write each fraction as a decimal.

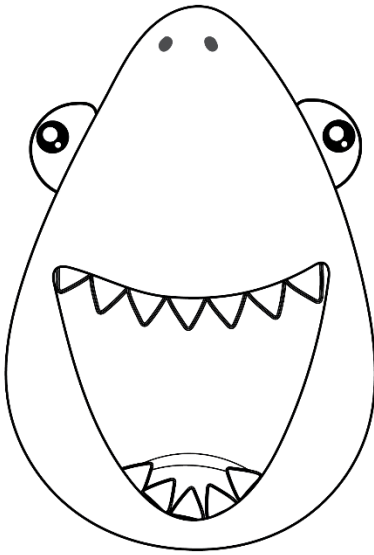
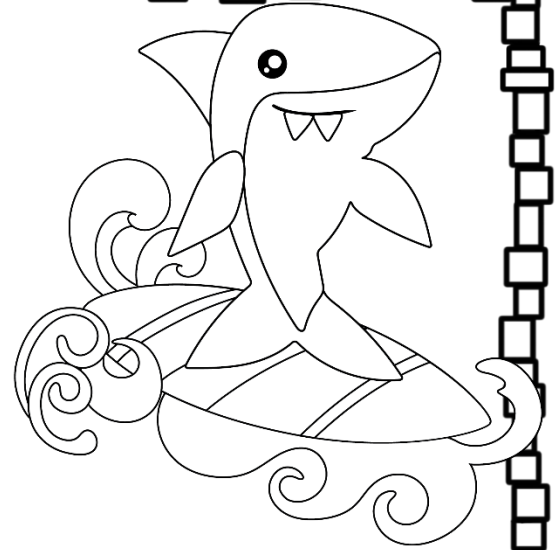

$$\frac{2}{10} = .2$$

$$\frac{4}{10} = .4$$

$$\frac{8}{10} = .8$$

$$\frac{9}{10} = .9$$

$$\frac{17}{100} = .17$$

$$6 \frac{30}{100} = 6.3$$

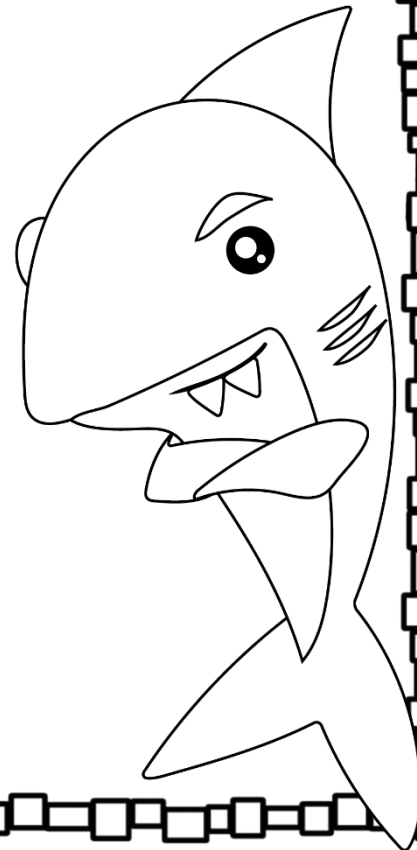

ANSWER KEY

Fractions & Decimals

Directions:

Write each fraction as a decimal.

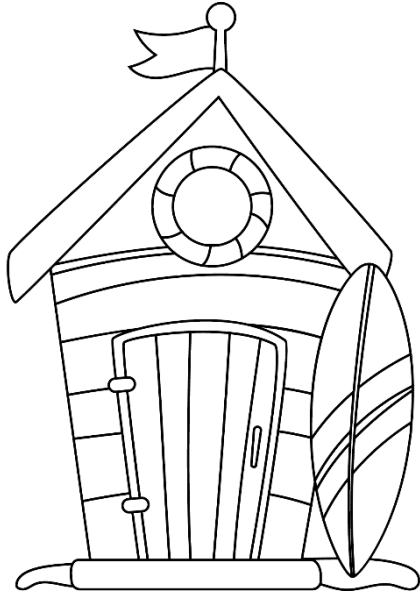

$$\frac{4}{50} = .08$$

$$\frac{4}{25} = .16$$

$$\frac{13}{20} = .65$$

$$\frac{9}{50} = .18$$

$$\frac{7}{20} = .35$$

$$\frac{11}{25} = .44$$

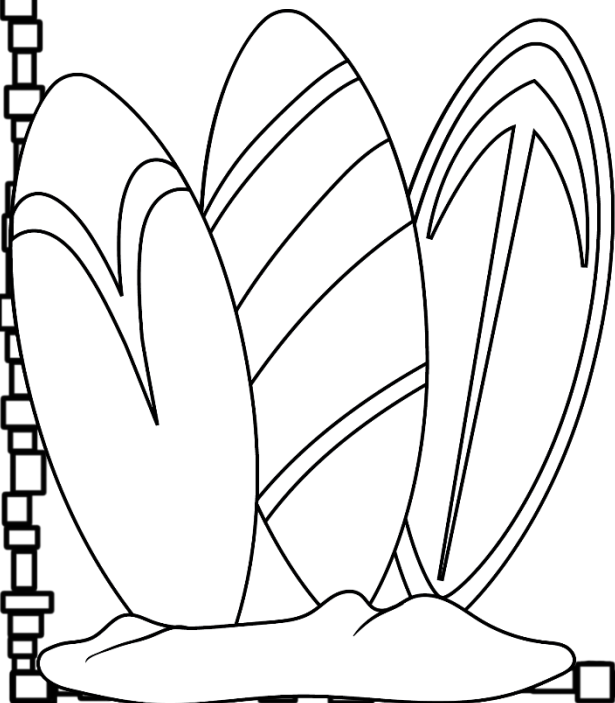
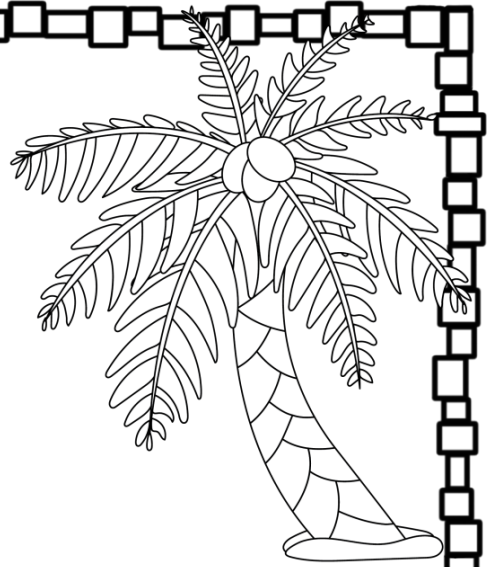

ANSWER KEY

Fractions & Decimals

Directions:

Write each decimal as a fraction in lowest terms.

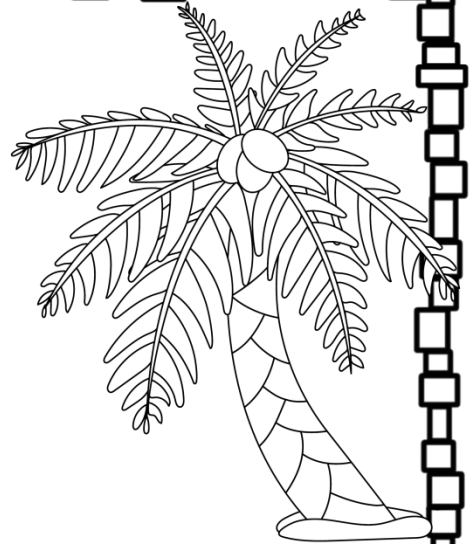

$$6.09 = 6 \frac{9}{100}$$

$$2.41 = 2 \frac{41}{100}$$

$$7.09 = 7 \frac{9}{100}$$

$$41.73 = 41 \frac{73}{100}$$

$$70.37 = 70 \frac{37}{100}$$

$$835.93 = 835 \frac{93}{100}$$

$$264.58 = 264 \frac{29}{50}$$

ANSWER KEY

Money Word Problems

Directions: Find the elapsed time.



Trevor bought a piece of pizza for \$1.75 and a drink for .59. How much did he spend?

\$2.34

Haley bought a bag of popcorn for \$3.15 and a drink for \$1.99. How much did she spend?

\$5.14

Kila bought three movie tickets for her friends. Each ticket was \$8.25. How much did she spend?

\$24.75

Miles had \$20. He bought a movie ticket for \$7.50 and popcorn for \$4.25. How much money does he have left?

\$8.25

Lincoln is going to buy two movie tickets for \$7.50 each. He also wants to buy a drink for \$2.75 and candy for \$2.50. He has \$20. Does he have enough money?

no

Sylvia spent \$18 at the movies. She bought a ticket for \$7.50 and a drink for \$4.00. She also bought a bag of popcorn. How much did the popcorn cost?

\$6.50

ANSWER KEY

Telling Time Word Problems

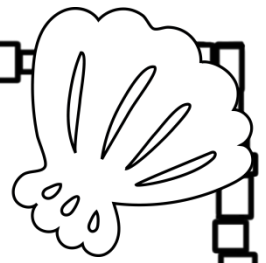

Directions: Read and solve each word problem.

It is 6:30. What time will it be in 2 hours and 15 minutes?

8:45

It is 3:15. What time will it be in 3 hours and 30 minutes.

6:45

It is 1:45. What time will it be in 4 hours and 10 minutes?

5:55

It is 8:45. What time was it 2 hours and 30 minutes ago?

11:15

It is 10:50. What time was it 4 hours and 10 minutes ago?

6:30

It is 5:30. What time was it 3 hours and 20 minutes ago?

2:10

ANSWER KEY

Finding the perimeter.

Directions: Add the length of the sides to find the perimeter of each shape.

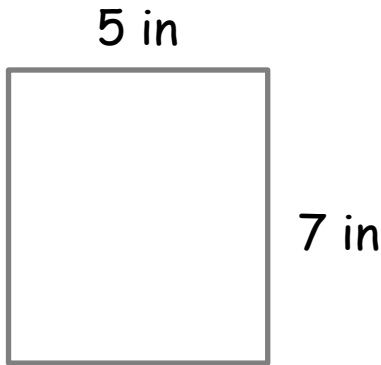
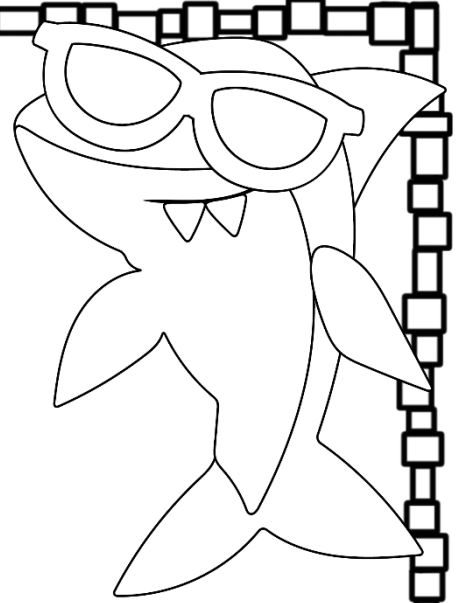

The perimeter is:
24 in

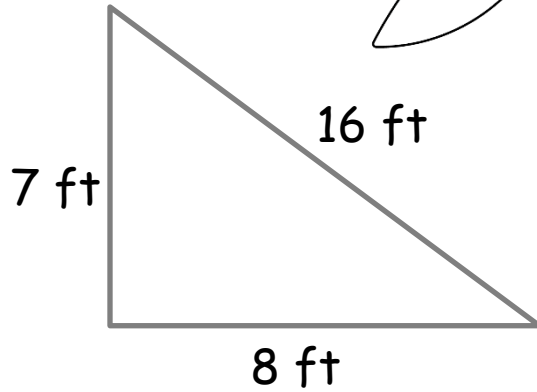

The perimeter is:
31 ft

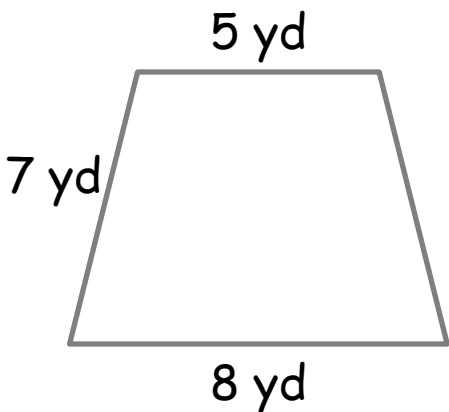

The perimeter is:
27 yd

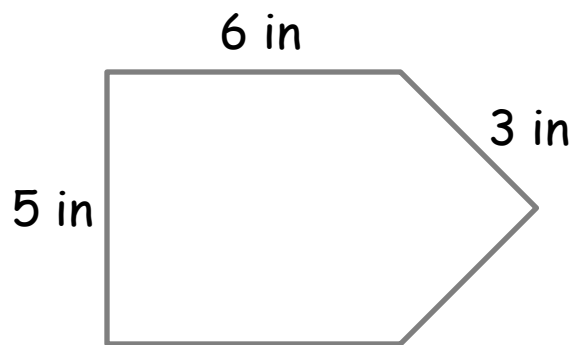

The perimeter is:
23 in

ANSWER KEY

Finding the Area

Directions: Multiply the length by width to find the area.

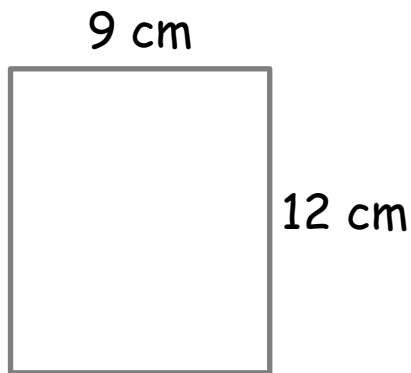
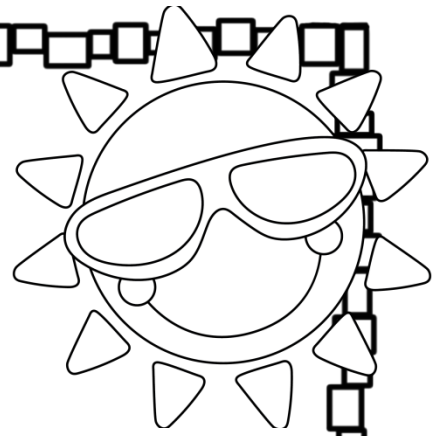

The area is:
 108 cm^2



The area is:
 51 m^2

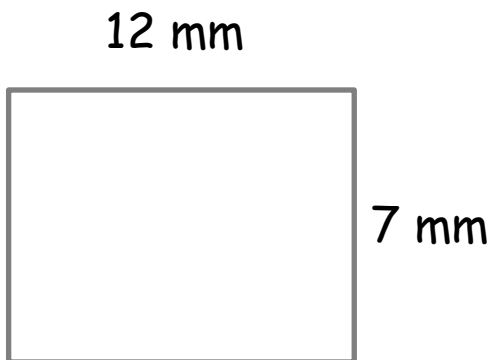

The area is:
 84 mm^2

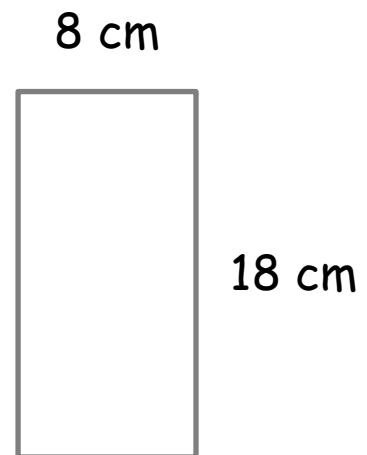

The area is:
 144 mm^2

ANSWER KEY

Identifying Angles

Directions: Identify each angle below as acute, right or obtuse.

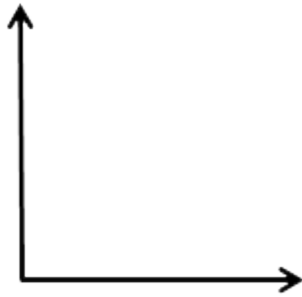
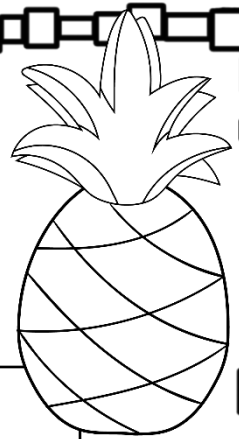

right

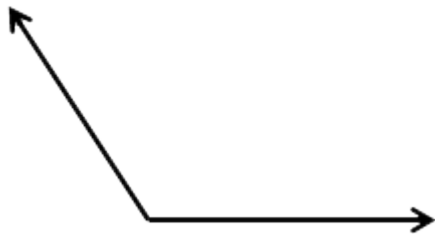

obtuse

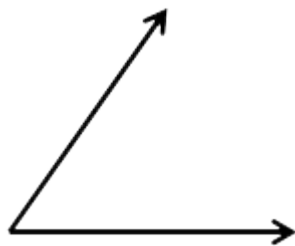

acute

ANSWER KEY

Label the Triangles

Directions: Label each triangle: equilateral, isosceles or scalene.

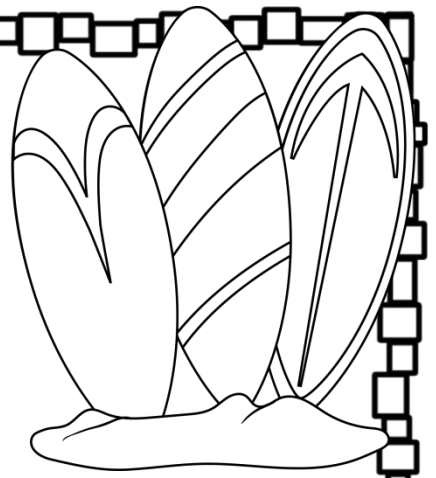

right



scalene

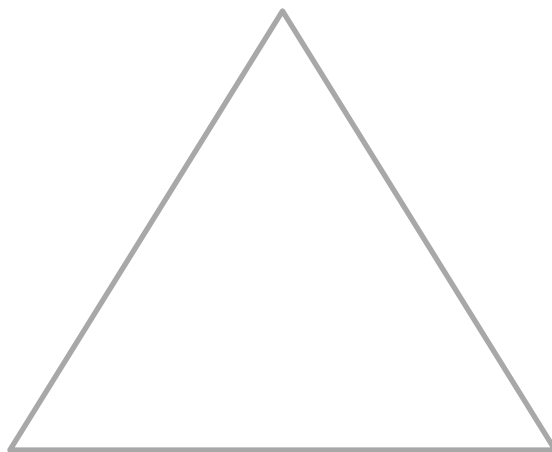

isosceles