

TRUE SIZE VIEW

DETAIL A
ALL ROUNDS R 3.00

BOTTOM LUGS FLUSH WITH BOTTOM OF FRONT GRILL

NOTE: TOP LUGS ATTACH TO TOP FRONT GRILL SCREW THROUGH 4 LUGS
BOTTOM LUGS ATTACH TO BOTTOM FRONT GRILL WITH GLUE PINS 4 LUGS 4 PINS

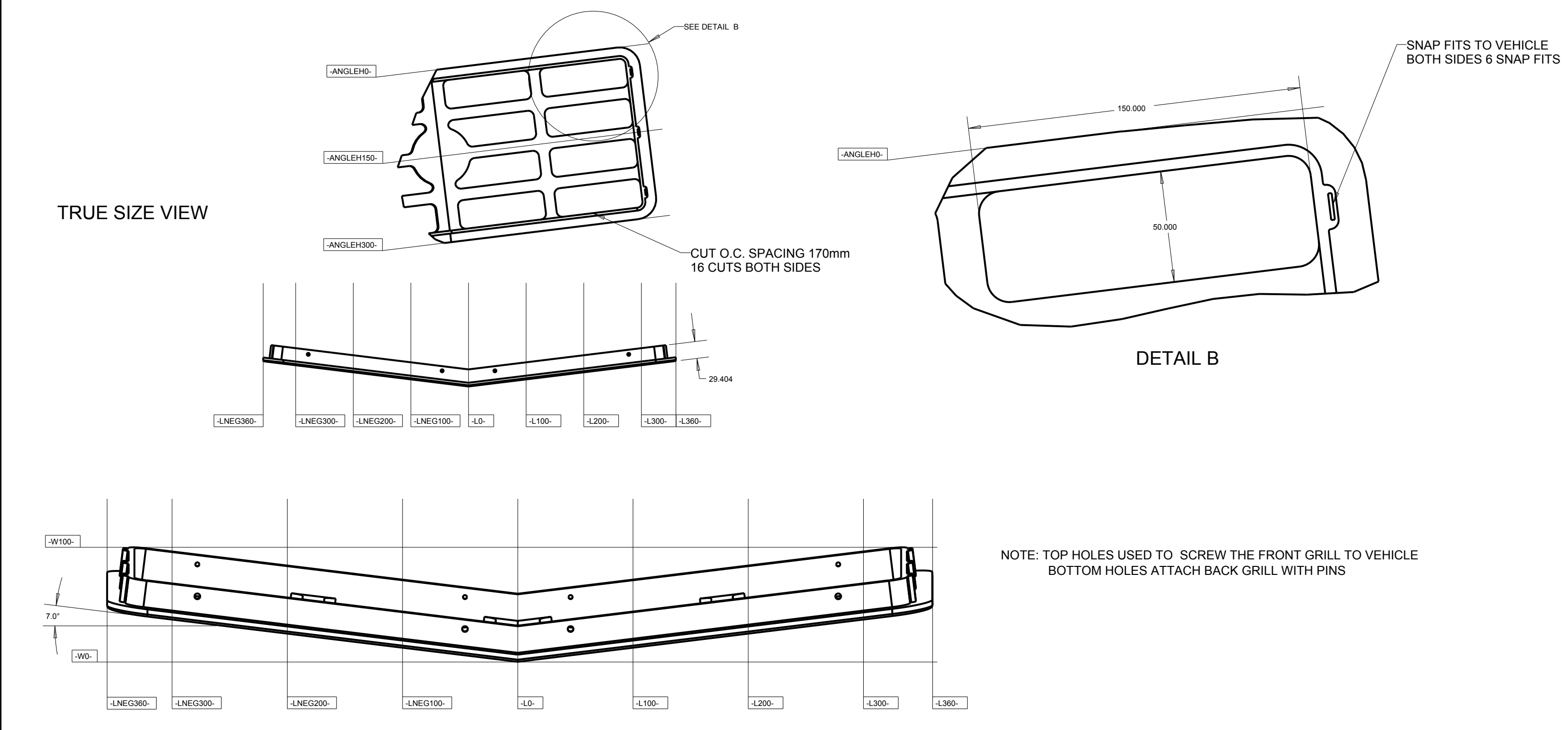

TRUE SIZE VIEW

DETAIL B

NOTE: TOP HOLES USED TO SCREW THE FRONT GRILL TO VEHICLE
BOTTOM HOLES ATTACH BACK GRILL WITH PINS

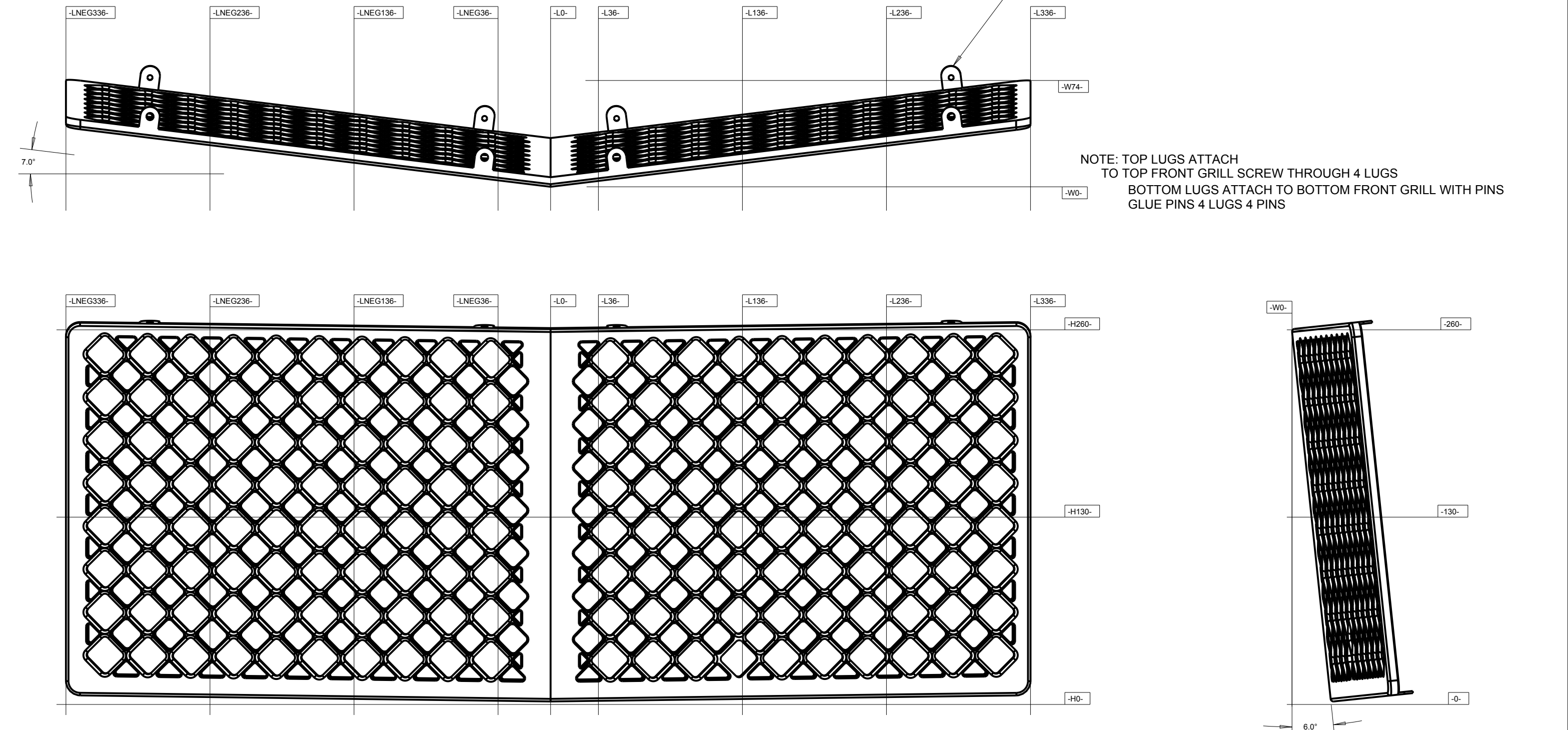

2 BACK GRILL
MATERIAL: TPO PLASTIC

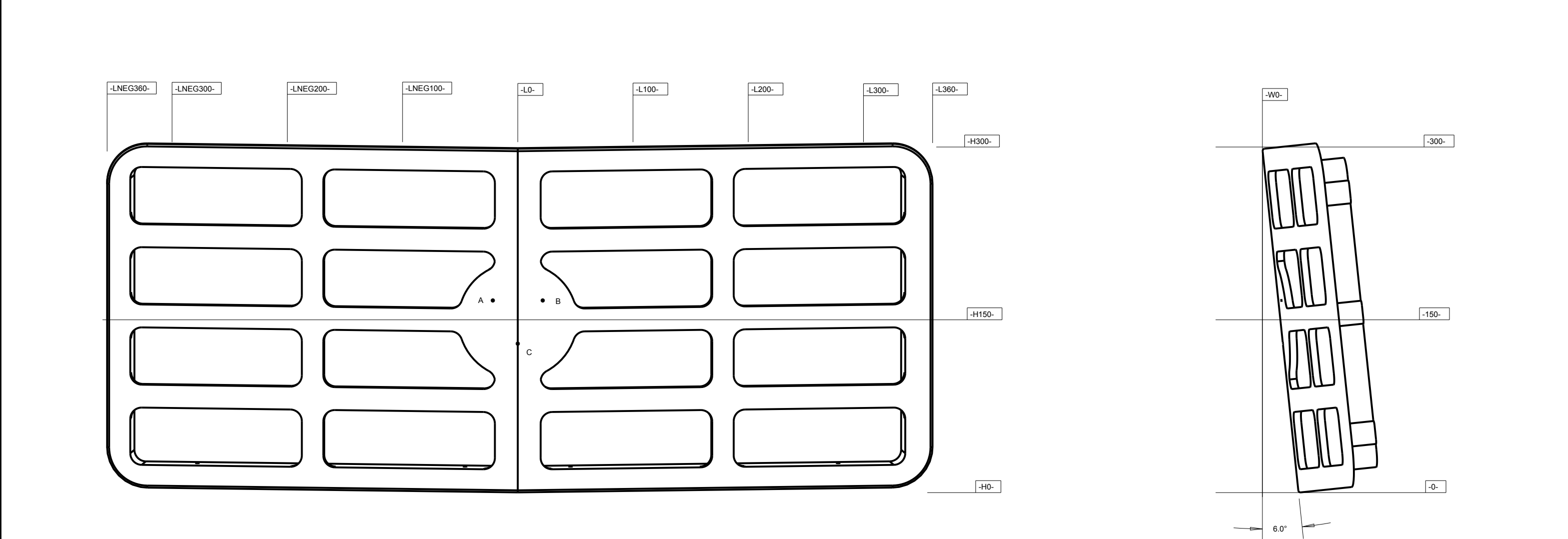

1 FRONT GRILL
NOTE: BADGE PINS ATTACH TO HOLES A, B, C ON PART
MATERIAL: PC ABS PLASTIC CHROMED

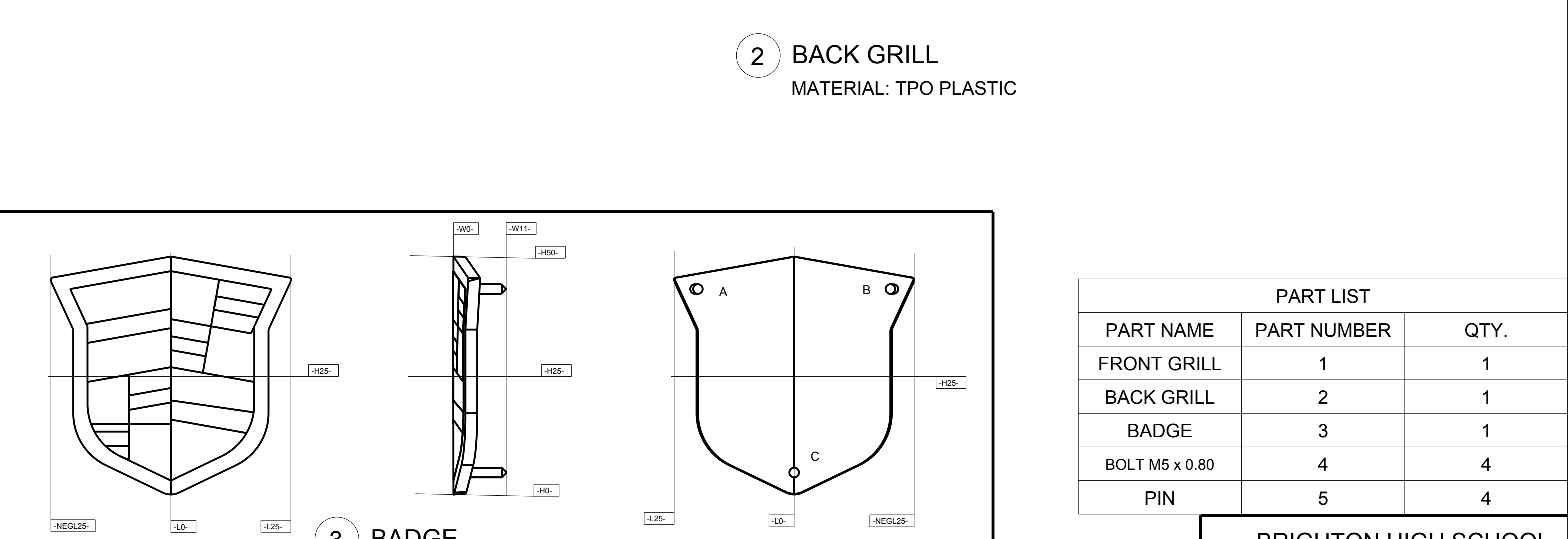

3 BADGE
NOTE: BADGE ATTACHED TO PART WITH PINS A, B, C
PINS OF BADGE ATTACHED WITH GLUE
MATERIAL: PC ABS PLASTIC CHROMED

PART LIST		
PART NAME	PART NUMBER	QTY.
FRONT GRILL	1	1
BACK GRILL	2	1
BADGE	3	1
BOLT M5 x 0.80	4	4
PIN	5	4

DIMENSIONAL TOLERANCE			DWG:ASBE CADILLAC TRUCK GRILL	
.X = ± .1	DWG BY: GILLIAN POWERS		HR: 2ND	
.XX = ± .05	DATE: 11/25/13		SCALE: NONE	
.XXX = ± .005	SH: 1-1			
ANGLES = ± 1°				

BRIGHTON HIGH SCHOOL
BRIGHTON, MI