

METRIC

EXPLODED VIEW

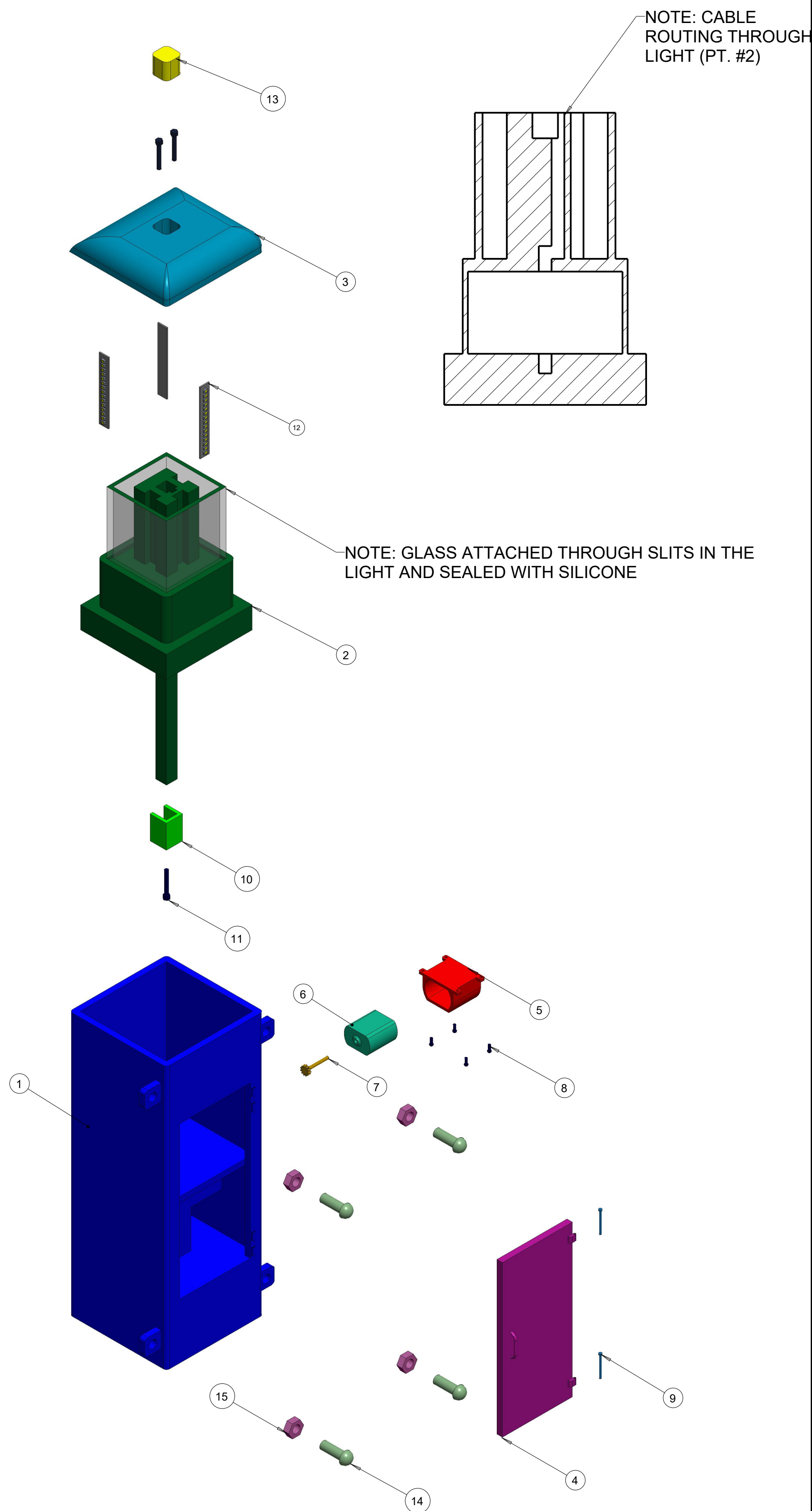

ASSEMBLED ISOMETRICS

CLOSED STATE

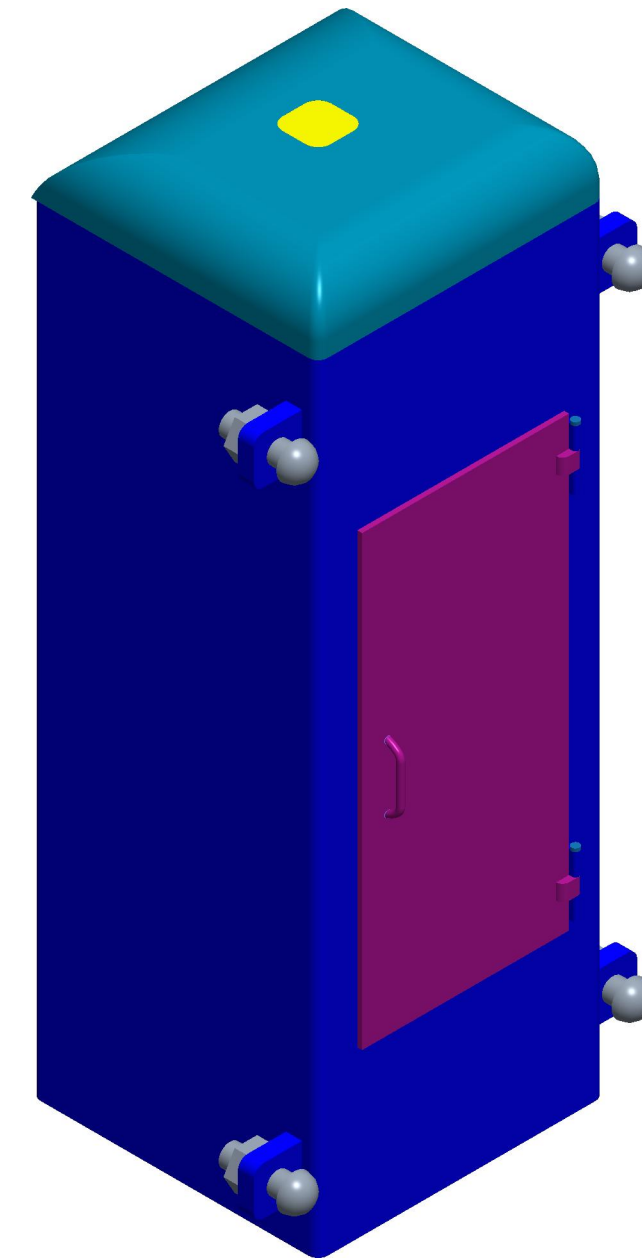

OPEN STATE

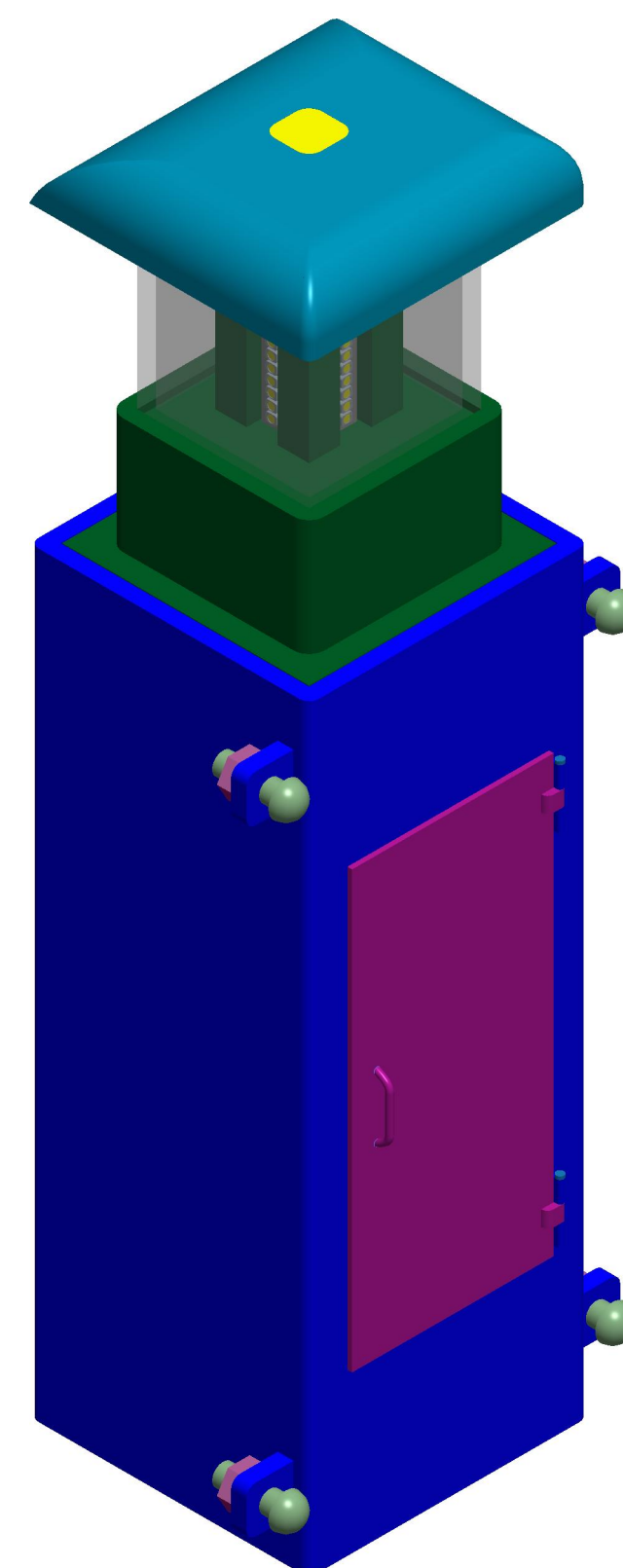

FULLY ASSEMBLED TRUCK BED

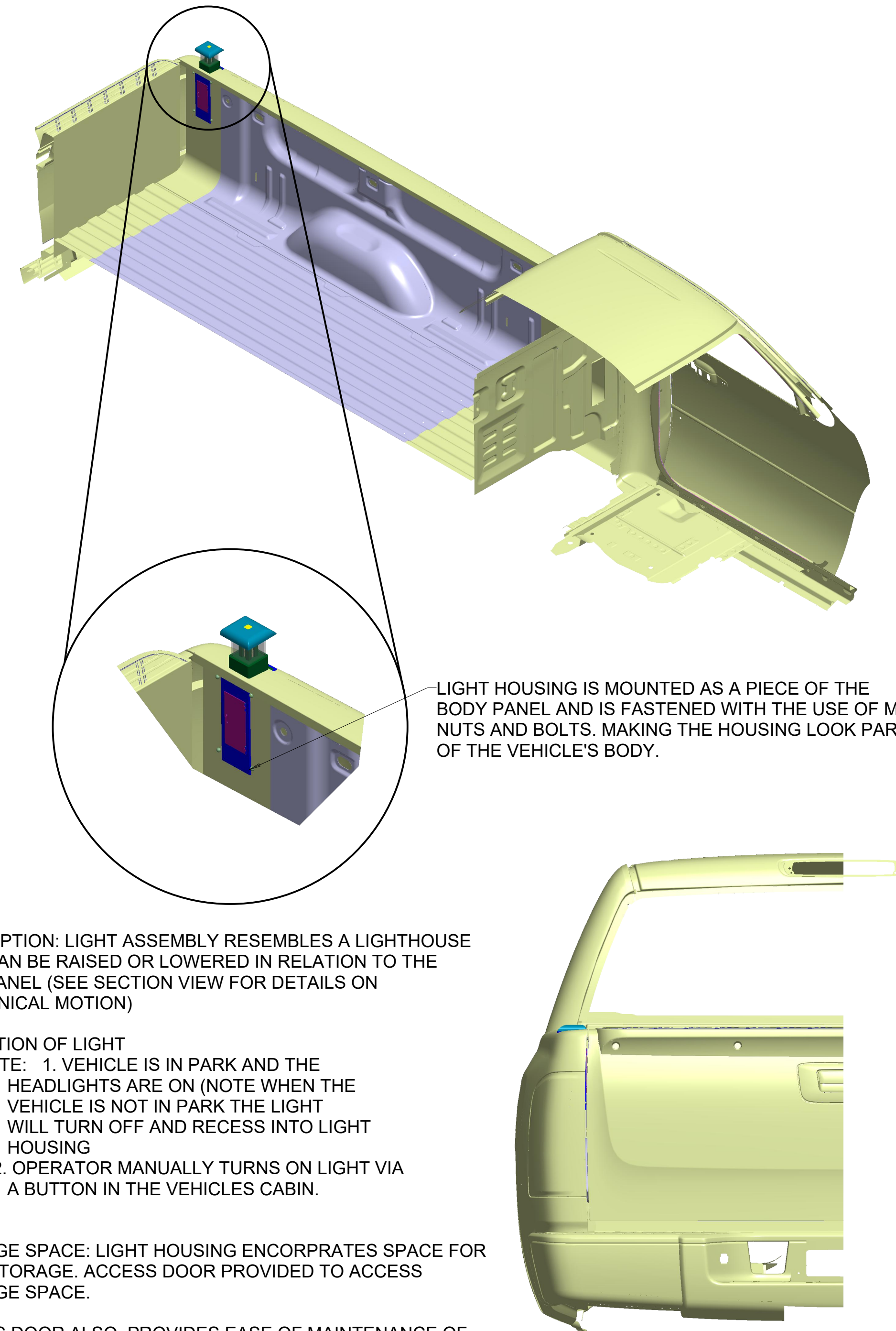

MECHANISM SECTIONED VIEW

THE LIGHT IS LIFTED BY A LINEAR GEAR SYSTEM, THIS SYSTEM IS MOVED BY THE USE OF A MOTOR THAT CONTROLS THE HEIGHT BY USING A RACK AND PINION GEAR. THIS ALLOWS FOR EASY OPERATION AND EASY ASSEMBLY

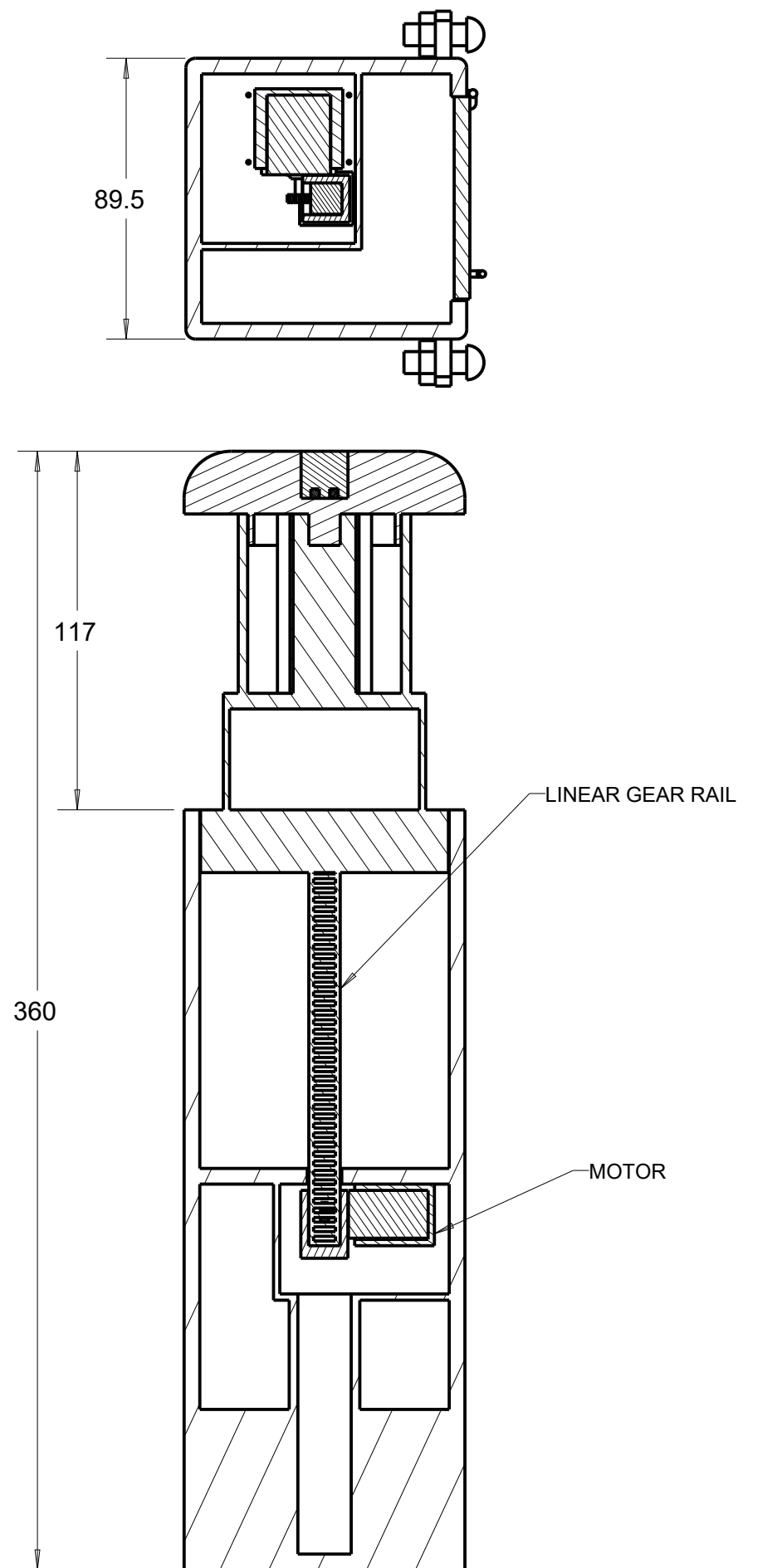

PARTS LIST		
PART #	PART NAME	QTY.
1	LIGHT HOUSING	1
2	LIGHT SLIDE	1
3	LIGHT CAP	1
4	HOUSING DOOR	1
5	MOTOR HOUSING	1
6	MOTOR	1
7	MOTOR SHAFT	1
8	M2 SCREWS	4
9	HINGE PIN	2
10	GEAR RAIL ENDCAP	1
11	M3 SCREW	3
12	LED STRIP	3
13	FINISH PLUG	1
14	M7 BOLT	4
15	M7 NUT	4

ASSEMBLY INSTRUCTIONS

1. LIGHT HOUSING (PT. #1) IS TO BE MOUNTED INTO A PRECUT SECTION OF THE VEHICLES BODY PANEL BY THE USE OF M7 NUTS AND BOLTS (PT. #14/15)
2. MOTOR (PT. #6) IS TO BE ASSEMBLED BY SLIDING THE SHAFT (PT. #7) INTO THE MOTOR BODY UNTIL THERE'S A CLICK.
3. NEXT THE MOTOR FROM THE PREVIOUS STEP WILL BE INSERTED INTO THE MOTOR HOUSING (PT.#5). THEN THE WHOLE ASSEMBLED MOTOR WILL BE MOUNTED TO THE INSIDE OF THE LIGHT HOUSING FROM STEP ONE BY USING M2 SCREWS (PT. #8)
4. NEXT ASSEMBLE THE LIGHT ITSELF, TAKE THE LIGHT SLIDE (PT. #2) AND SLIDE IT INTO THE LIGHT HOUSING FROM STEP 1 THROUGH THE SLOT ON THE TOP OF THE BODY PANEL. ATTACH THE RAIL CAP (PT. #10) TO THE BOTTOM OF THE RAIL WITH M3 BOLTS (PT. #11)
5. NEXT ATTACH LEDS TO THE INSIDE OF THE LIGHT SLIDE FROM THE PREVIOUS STEP WITH ADHESIVE
6. ATTACHE LIGHT CAP (PT. #3) TO THE TOP OF THE LIGHT WITH 2 M3 BOLTS. THEN INSERT THE FINISH PLUG (PT. #13) WITH A FRICTION FIT
7. ATTACH DOOR (PT. #4) TO THE LIGHT HOUSING USING DOOR PINS (PT. #9) INTO HINGE HOLES ON DOOR (PT#) AND LIGHT HOUSING (PT#)

STUDENT NAME: COLLIN FINETTI

SCHOOL: BRIGHTON HIGH SCHOOL

GRADE LEVEL: 12 CATEGORY:

CREATIVE ENGINEERING

EMAIL ADDRESS: FINETTICJ@BRIGHTONK12.COM

TEACHER NAME: MATTHEW JOURDEN