

FULL ASSEMBLY VIEW

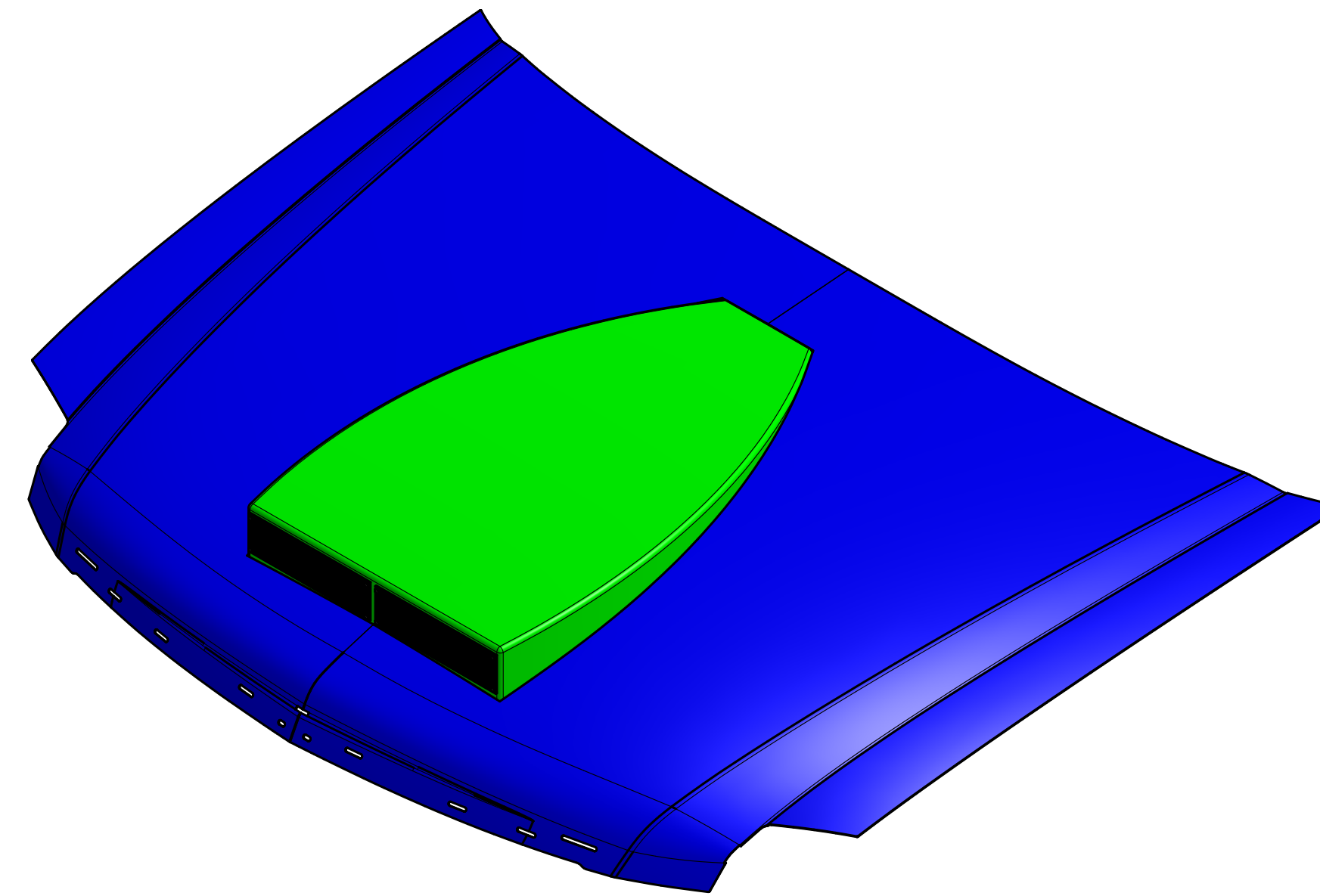

HOOD CUTOUT VIEW

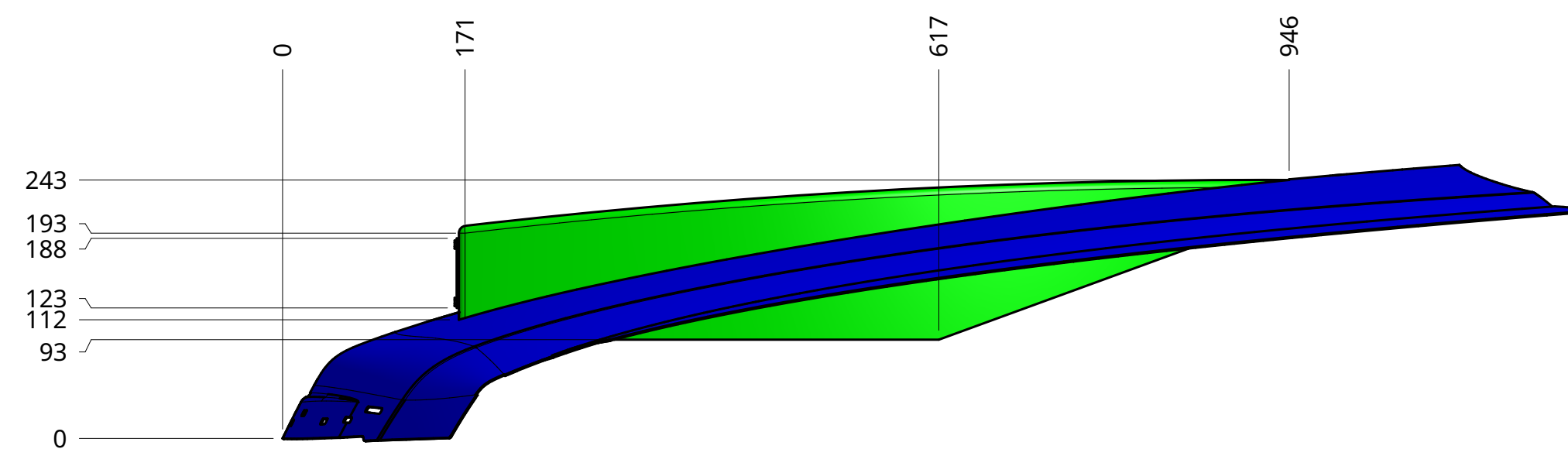
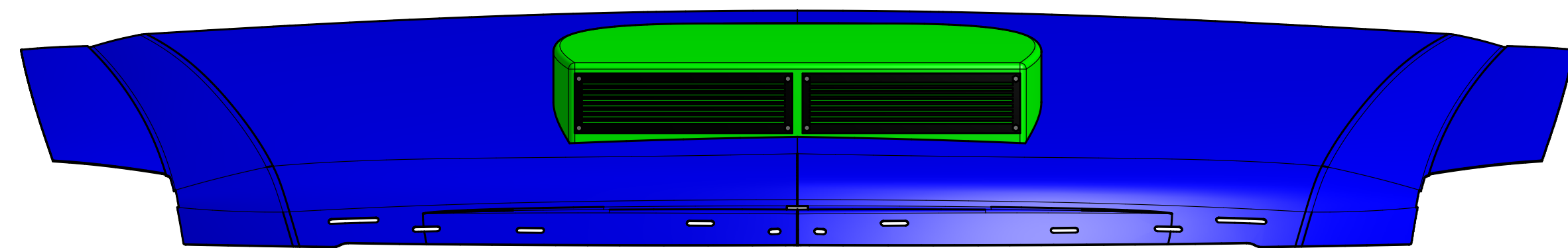
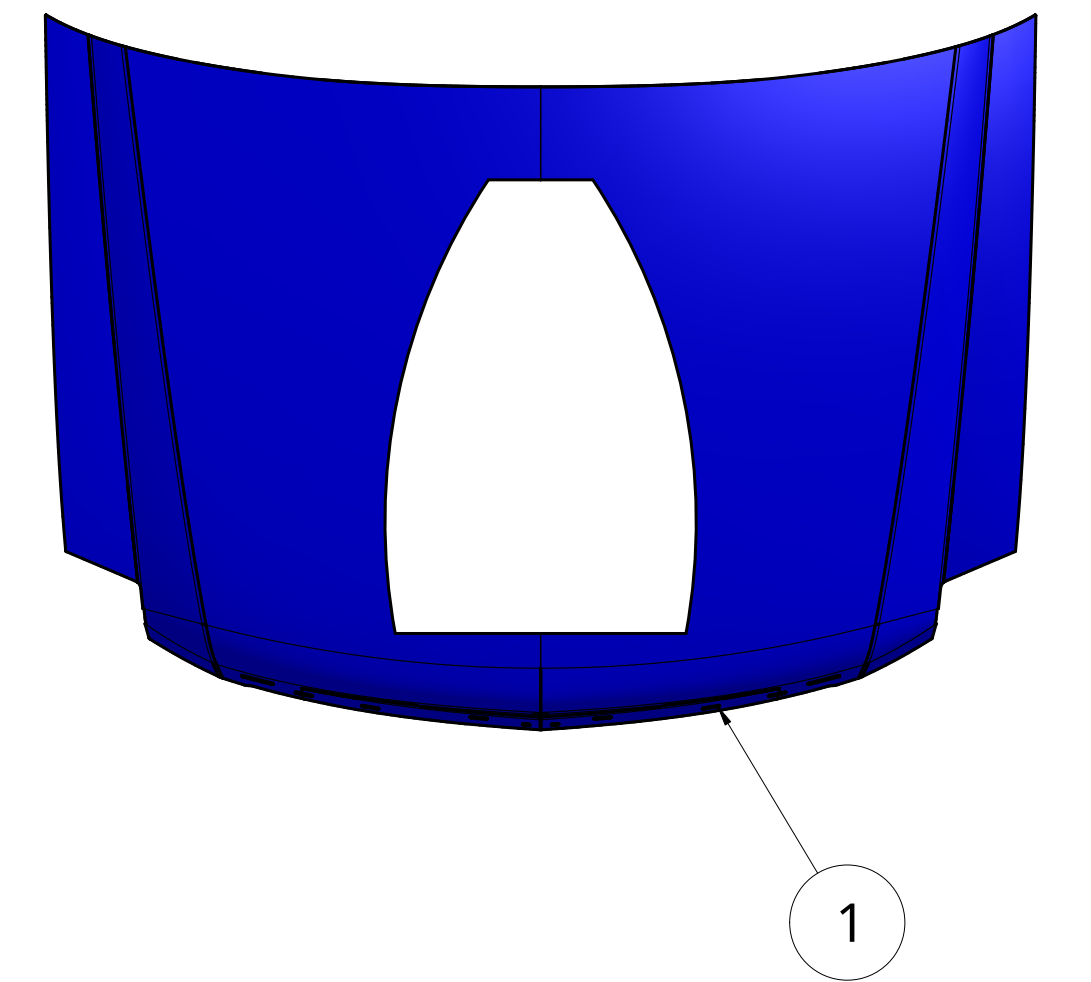

- ASSEMBLY INSTRUCTIONS:
- COAT GRILL EDGES WITH RUBBER SEALANT
  - PRESS OVER SCOOP VENT HOLE FROM FRONT (SEE ASSEMBLED HOOD SCOOP/ GRILL)
  - FASTEN GRILL TO HOOD SCOOP WITH SCREWS
  - SET HOOD SCOOP INTO HOOD CUTOUT UNTIL SNUG FIT
  - WELD HOOD SCOOP TO HOOD

METRIC

4	SCREW	8	1 OF 1
3	GRILL	2	1 OF 1
2	HOOD SCOOP	1	1 OF 1
1	HOOD	1	1 OF 1
PART #	PART NAME	QTY.	SHEET

NOTE:  
MATERIAL: ALUMINIUM  
GUAGE: 11

GRILL



ASSEMBLED HOOD SCOOP/ GRILL

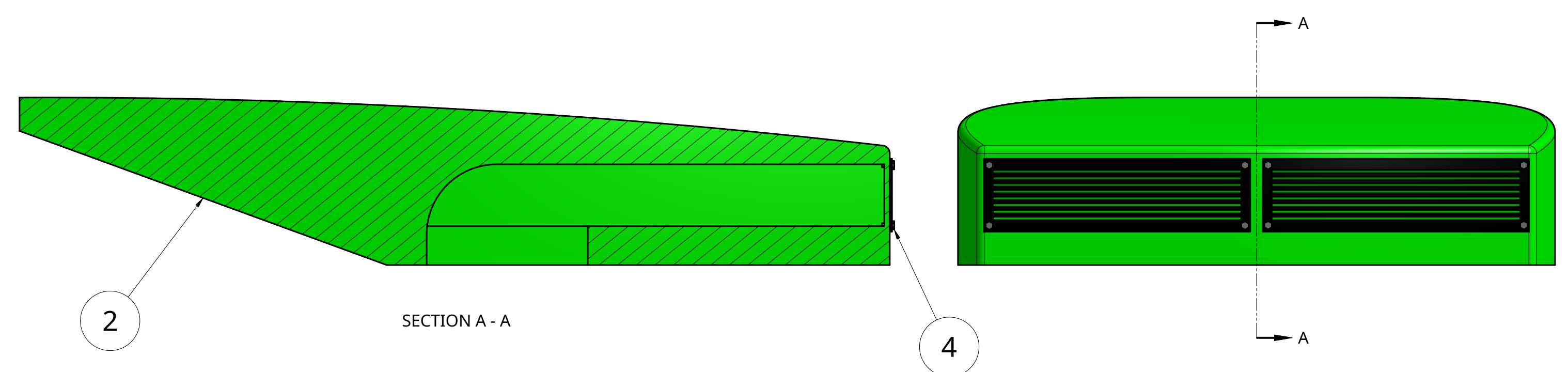

ASBE HOOD SCOOP  
STUDENT NAME: CAYDEN COATSWORTH  
SCHOOL: BRIGHTON HIGH SCHOOL  
GRADE LEVEL: CATEGORY:  
ENGINEERING DESIGN  
11  
EMAIL ADDRESS: COATSWORTHCT22@brightonk12.com  
TEACHER NAME: MATT JOURDEN