

SECTION A - A

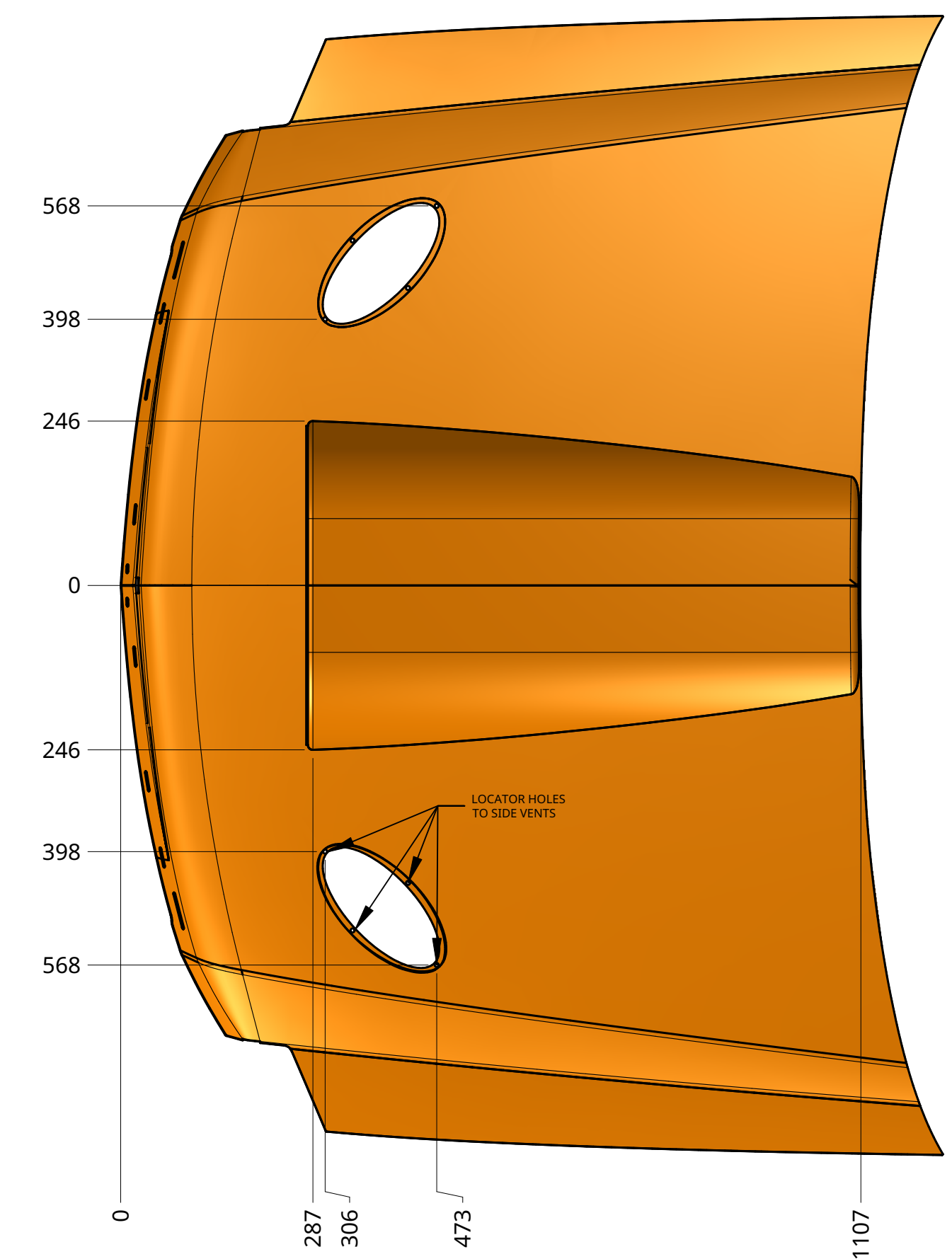

HOOD BOTTOM VIEWS
SHOWS HOOD SCOOP AND VENT FINISHED OPENINGS

3 VENT GRILL

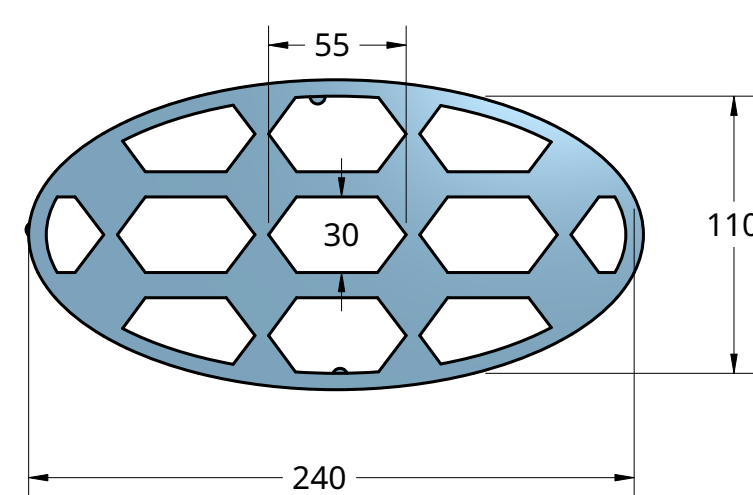
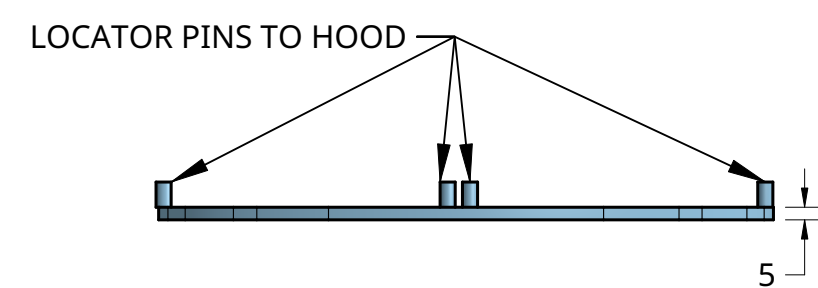

4 SCOOP GRILL

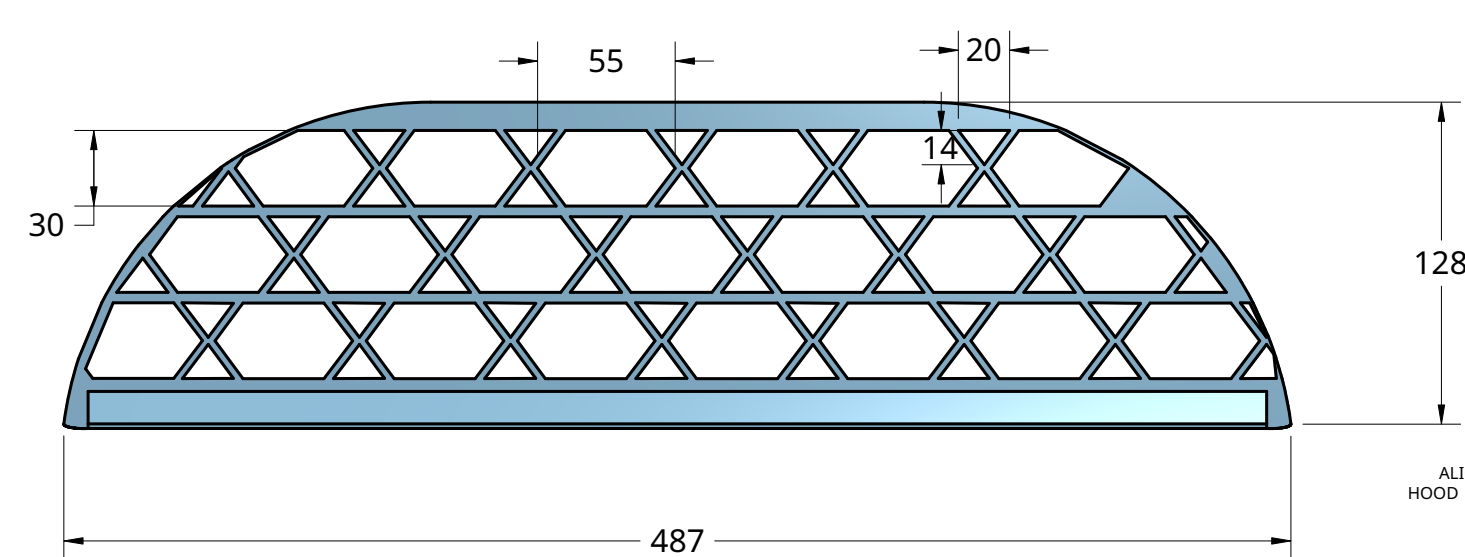
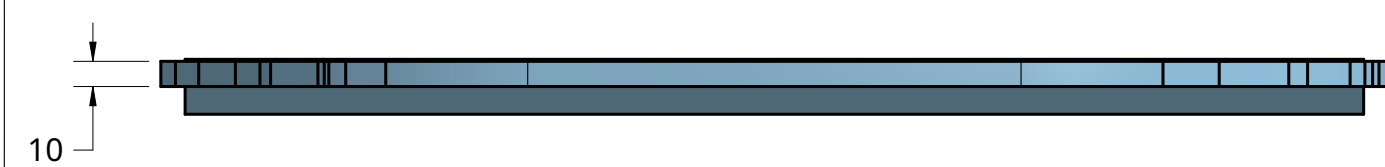

ASSEMBLY INSTRUCTIONS

- 1) PART 2 FORM PRESSED IN TO PART 1
- 2) PART 3 SLIDE FLUSH WITH FRONT OF PART 2
- 3) APPLY ADHESIVE TO INSIDE EDGE OF HOOD SCOOP
- 4) FILLET WELD INSIDE EDGE OF HOOD SCOOP AND PART 3
- 5) APPLY ADHESIVE TO LOCATOR PINS AND EDGE ON PART 4
- 6) PRESS FIT FIRMLY INTO LOCATOR HOLES ON HOOD
- 7) VINYL WRAP HOOD TO DESIRED COLOR

NOTE:
VENT HOLES
CUT AT FACTORY

METRIC

ITEM	QUANTITY	PART NUMBER	PART DESCRIPTION
HOOD	1	1	HOOD
HOOD SCOOP	1	2	COWL SCOOP
SCOOP GRILL	1	3	THE HEXAGONAL GRILL
VENT GRILL	2	4	SMALLER HEXAGONAL GRILL

STUDENT NAME: ZACH KRAMER	
SCHOOL: BRIGHTON HIGH SCHOOL	
GRADE LEVEL: 12	CATEGORY: ENGINEERING DESIGN
EMAIL ADDRESS: KRAMERZT21@BRIGHTONK12.COM	
TEACHER NAME: MR. MATT JOURDEN	