

**INSTRUCTIONS TO BIDDERS**  
**Purchase & Installation of CDL Training Simulators**  
**MID-EAST CAREER AND TECHNOLOGY CENTERS**

**Treasurer's Office**  
**400 Richards Road**  
**Zanesville, OH 43701**

For further information contact:

**Nanette Nolder**  
**Treasurer/CFO**  
**Phone: 740.454.0105**  
**Email: nnolder@mideastctc.org**

The Mid-East Career and Technology Centers are seeking bids from eligible bidders for the purchase and installation of 43 commercial driver's license (CDL) training simulators in its facilities. The project will include the purchase of all required hardware and software, as well as all work necessary to deliver, install, and integrate the simulators into the District's facilities and existing infrastructure. The District requires all responsible bidders to be able to provide CDL simulators that are easily convertible for training in the use of other types of equipment, including heavy equipment. The simulators must not require any internet connection and must be able to communicate to other simulators using network cabling.

Bids must be received in the Treasurer's Office, via delivery or mail no later than: **noon on August 9<sup>th</sup>, 2024.**

Envelopes shall be plainly marked: **CDL Training Simulator Project** on left, lower corner of envelope. Submit signed original bid and one (1) copy of the bid.

**Bidder is requested to use the District's Bid Form that is enclosed.**  
**No bid shall be considered unless made on the District's forms.**

LEGIBLE INFORMATION MUST BE GIVEN IN THE SPACES PROVIDED.

All federal, state, and local laws regarding competitive bidding, anti-competitive practices, and conflict of interest shall be applicable to this Invitation for Bid.

The School District is a tax-exempt entity; this certificate is available upon request.

The School District intends to accept the lowest responsive and responsible bid, however, it reserves the right to reject any and all, or parts of any and all, bids and to waive any irregularities in a bid, and to accept the bid or bids which the judgment of proper officials, is in the best interest of the School District.

No bid may be withdrawn for a period of sixty days after the scheduled closing time for receipt of the bids.

## PROJECT PLANS/SPECIFICATIONS

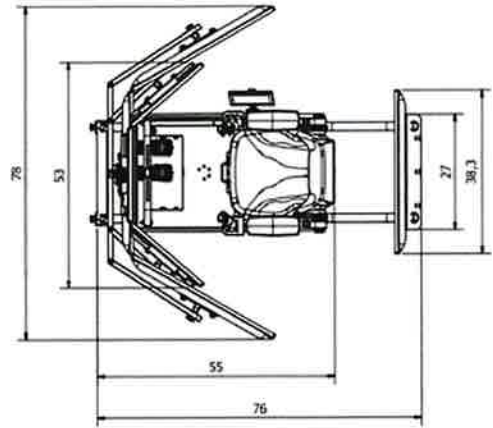
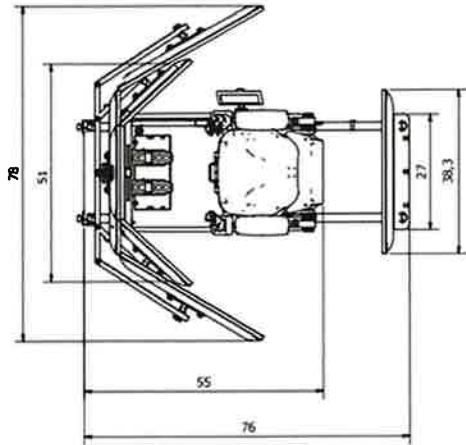
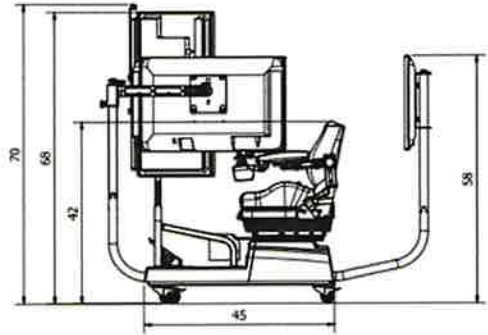
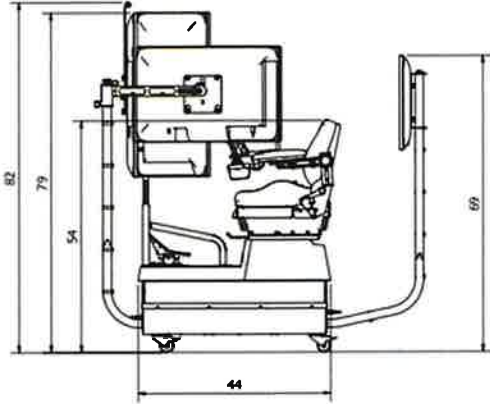

### **MUMB**

Without screens and stands

HxWxL: 54,2x27x44,5 in

Weight approx. 375 lb

**Screens in Portrait View:**

HxWxL: 79,4x52,8x55,5 in

Weight approx. 510 lb

**Screens in Landscape View:**

HxWxL: 69,3x79,2x55,5 in

Weight approx: 510 lb

**Rear Screen**

Total length with rear screen: 76 in

Weight approx: 576 lb with three screens in the front

**Motion platform**

Stroke Length: 1,5 in

**Electrical**

Connection: 110V, 15A

Power Max: 800W



### **MU**

Without screens and stands

HxWxL: 42,5x27x41,3 in

Weight approx. 254 lb

**Screens in Portrait View:**

HxWxL: 68,1x52,7x41,3 in

Weight approx. 388 lb

**Screens in Landscape Mode:**

HxWxL: 57,8x79,2x41,3 in

Weight approx: 388 lb

**Rear screen**

Total length with rear screen: 76 in

Weight approx: 455 lb with three screen in the front

**Electrical**

Connection: 110V, 15A

Power Max: 800W

**BID FORM  
MID-EAST CAREER AND TECHNOLOGY CENTERS  
TREASURER'S OFFICE**

Reply to: **CDL Training Simulator Project**

No Later Than: **noon on August 9<sup>th</sup>, 2024**

The undersigned proposes and agrees to furnish any or all items bid at the prices stated herein.

---

The District shall not consider any bid that cannot guarantee timely completion of the entire project by **November 1, 2024**.

Provide all needed material, labor, equipment, and any associated delivery or transportation costs to complete the installation and integration of the simulators fitting the prescribed specifications included with the enclosed Project Plans, and all related work.

Materials Cost: \$ \_\_\_\_\_ Materials

Labor Cost: \$ \_\_\_\_\_ Labor

**Total Cost (Materials + Labor):** \$ \_\_\_\_\_ **Total**

For any questions regarding the project, contact:

**Nanette Nolder**  
**Treasurer/CFO**  
**Phone: 740.454.0105**  
**Email: nnolder@mideastctc.org**

Bids must contain the name of every person interested therein, including any partners, sub-contractors, and joint ventures, and be accompanied by a (i) bid and performance bond in the full amount of the bid tendered as a guarantee that the bidder will, if the award is made to the bidder, enter into a proper contract with the board of education for the project, or (ii) certified check, cashier's check, money order, or letter of credit in an amount equal to ten percent (10%) of the bid tendered as a guarantee that the bidder will, if the award is made to the bidder, enter into a proper contract with the Board of Education for the project and furnish a performance bond for the amount of the contract at the time the bidder executes the contract. All such bonds, certified checks, cashier's checks, money orders, and letters of credit shall be payable to the Mid-East Career and Technology Centers Board of Education.

All proper contracts entered into with the Board of Education for the project shall substantially comply with the Standard Terms and Conditions set forth in this Bid Form.

The successful bidder must have and maintain current workers compensation insurance, comprehensive general liability and automobile insurance for bodily injury, death, or loss of or

damage to property of third persons in the minimum amount of \$1,000,000.00 per occurrence and \$3,000,000 in the aggregate, with the Mid-East Career and Technology Centers Board of Education as an additional named insured.

THE UNDERSIGNED HEREBY CERTIFIES THAT ITEMS FURNISHED AS A RESULT OF THIS BID WILL BE IN FULL ACCORDANCE WITH THE INSTRUCTION TO BIDDERS, THIS BID FORM, AND THE MID-EAST CAREER AND TECHNOLOGY CENTERS SPECIFICATIONS APPLYING THERETO UNLESS EXCEPTIONS ARE STATED ABOVE. THE MID-EAST CAREER AND TECHNOLOGY CENTERS INTENDS TO ACCEPT THE LOWEST RESPONSIVE AND RESPONSIBLE BID, BUT RESERVES THE RIGHT TO REJECT ANY AND ALL, OR PART OF ANY AND ALL, BIDS, TO WAIVE ANY IRREGULARITIES IN A BID, OR TO ACCEPT THE BID OR BIDS WHICH IN THE JUDGMENT OF PROPER OFFICIALS, IS TO THE BEST INTEREST OF THE DISTRICT.

**Bidding Company:** \_\_\_\_\_

**Address:**  
\_\_\_\_\_

\_\_\_\_\_

<b>City</b>	<b>State</b>	<b>Zip</b>
-------------	--------------	------------

**Phone No.:** \_\_\_\_\_ **Fax No.:** \_\_\_\_\_

**Email:** \_\_\_\_\_

**Prepared By:** \_\_\_\_\_  
**Name & Title (print or type)**

**List any and all additional interested persons, including any partners, sub-contractors, and joint ventures:**  
\_\_\_\_\_  
\_\_\_\_\_  
\_\_\_\_\_  
\_\_\_\_\_

**Signature:** \_\_\_\_\_

## STANDARD TERMS AND CONDITIONS

1. **BILLING:** The combined price of materials and labor shall not exceed the total price for the project stated above and shall be billed to the Mid-East Career and Technology Centers Board of Education ("District") at prices not exceeding those stated on the purchase order.
2. **INVOICE:** Prepayment or progress payments are not permitted unless prior permission is obtained from the Treasurer's Office. You shall invoice the district only for services fully rendered. Invoices shall be delivered to the District within ten (10) days of the completed work. The District will have thirty (30) days to pay invoices in full.
3. **TAXES:** The District is a tax-exempt entity. The District's certificate is available upon request. You are responsible for all Social Security taxes and Workers' Compensation contributions for yourself or any of your employees.
4. **CANCELLATION:** The District reserves the right to cancel this order by written notice if you do not fulfill your contractual obligations with respect to timeliness, quality and/or any other reason.
5. **DEFAULT PROVISIONS:** In case of your default, the District will provide you with written notice an opportunity to cure the defect within ten (10) business days. If you fail to cure the default within the time specified, the District may procure the materials and/or services from other sources and hold you responsible for any excess costs occasioned thereby and any other damages permitted by law.
6. **NO VERBAL AGREEMENTS:** The District will be bound only by the terms and conditions of this order and will not be responsible for verbal agreements made by any officer or employee of the District. In order to be binding on the parties, any changes made to these Terms and Conditions shall be in writing and signed by both parties.
7. **INSPECTION:** The District may inspect the materials ordered and services rendered hereunder during construction and/or preparation at reasonable times and shall have the right to inspect such materials and services upon completion. Materials and/or services furnished hereunder may at any time be rejected for defects revealed by inspection, analysis, or use after delivery or completion even though such items may have previously been inspected and accepted. Such rejected items may be returned to you for a full refund to the District including shipping and transportation charges.
8. **WARRANTY:** You warrant that all materials and all services provided shall not violate any federal, state, or local laws, regulations, or orders. You warrant all materials delivered and services rendered to be free from defects of material or workmanship, to be good quality, and to conform strictly to any specifications, drawings or samples which may have been specified or furnished by the District. Said warranties shall not negate nor limit any implied warranties of merchantability or fitness. This warranty shall survive any inspection, delivery, acceptance, or payment by the District.
9. **SAVE HARMLESS:** You shall indemnify and hold the District, its officers, elected officials, agents, consignees, employees, volunteers, and representatives harmless from and against all expenses, damages, claims, suits, or liabilities (including attorney's fees of the District) of every kind whatsoever by reason of, arising out of, or in any way connected with, accidents, occurrences, injuries or losses to or any person or property which may occur before or after acceptance of the completed services by the District upon or about in any way due to resulting from, in whole or in part, the preparation, manufacture, construction, completion, and/or delivery of the materials and/or services, including such as are caused by your subcontractors and excluding only such as are caused by the sole negligence of the District other than where

the District's negligence consists of its failure to discover a condition caused or permitted to exist by you or any subcontractor of yours.

10. **INSURANCE:** While this Agreement is in effect, you shall maintain insurance with an insurance company lawfully authorized to do business in Ohio for protection from (i) claims under workers' compensation acts and other employee benefit acts that are applicable; (ii) claims for damages because of personal injury, death, contractual liability, and property damage. Such insurance shall have a combined single occurrence limit of not less than one million dollars (\$1,000,000) and a combined aggregate limit of not less than three million dollars (\$3,000,000) and name the District as an additional insured with respect to the work done under this Agreement. In addition, such policies shall protect all your subcontractors, if any. Proof of such insurance shall be furnished by you to the District upon request. You agree to make prompt written report to the insurance company involved of all accidents, occurrences, injuries, or losses which may occur and of any and all claims made against the persons insured under said policies of insurance and to send copies of such reports to the District within twenty-four (24) hours of the time that you obtained knowledge of the occurrence thereof.
11. **EXAMINATION OF PREMISES:** Since work is to be performed hereunder on the premises of the District, you represent that you have examined the premises, the Project Plans, and any specifications or other documents furnished in connection with this project and that you have satisfied yourself as to the condition of the premises and site and agrees that no allowance shall be made in respect of any error as to such on your part.
12. **CLEANING OF PREMISES:** Since work is to be performed hereunder on the premises of the District, you shall at all times keep the premises free from accumulation of waste material or rubbish. At the completion of the work required under this Agreement, you shall remove any and all waste material or rubbish that was a result of your performance of work under this Agreement and leave the premises broom clean.
13. **EQUAL EMPLOYMENT OPPORTUNITY:**
  - a) You agree that you will not discriminate against any employee or applicant for employment because of race, color, religion, sex, ancestry, national origin, place of birth, age, marital status, or handicap with respect to employment, upgrading promotion, or transfer, recruitment or recruitment advertising, lay-off determination; rates of pay or other forms of compensation; and selection for training, including apprenticeship.
  - b) It is expressly agreed and understood by you that Section 13 (a) constitutes a material condition of this contract as fully as specifically rewritten herein, also that failure to comply therewith shall constitute a breach thereof entitling the District to terminate the contract at its option.
14. **AGREEMENT TO BE EXCLUSIVE:** This constitutes the entire agreement between the parties and supersedes all other oral agreements only when there is no executed contract between the parties. The parties acknowledge and agree that neither of them has made any representation with respect to the subject matter of this purchase order or any representation inducing the execution and delivery of this purchase order, except such representations as are specifically set forth here, and each party acknowledges that it has relied on these representations in connection with its dealings with the other.
15. **GOVERNING LAW:** This contract, the performance under it, and all suits and special proceedings under it, shall be construed in accordance with the laws of the State of Ohio. In any action, special proceeding or other proceeding that may be brought arising out of, in connection with, or by reason of this agreement, the laws of the State of Ohio shall be

applicable and shall govern to the exclusion of the laws of any other forum, without regard to the jurisdiction in which the action or special proceeding may be instituted.

16. **ADDITIONAL RIGHTS:** Any rights or remedies granted to the District in any part of this Agreement shall not be exclusive of, but shall be in addition to, any other rights or remedies granted in another part of this Agreement and any other rights or remedies that the District may have at law or in equity in any such instance. Any litigation arising from disputes herein shall be instituted only in Noble County, Ohio.
17. **INDEPENDENT CONTRACTOR:** The contractor, his assigns, heirs, successors, employees and any and all subcontractors are independent contractors and are not agents and/or employees of the District.
18. **ASSIGNMENT:** This Agreement is not assignable to any other entity or contractor. Assignment of this Agreement shall void the Agreement.