

**SECTION 00 01 01
PROJECT TITLE PAGE**

PROJECT MANUAL

FOR



**ORANGE COUNTY SCHOOLS
200 E KING STREET,
HILLSBOROUGH, NORTH CAROLINA 27278**

**NEW HOPE ELEMENTARY SCHOOL BUILDING ENCLOSURE MAINTENANCE & REPAIR
1900 NEW HOPE CHURCH ROAD,
CHAPEL HILL NORTH CAROLINA 27514
REI PROJECT NO. 023RAL-049**

04-10-2024

PREPARED BY:



**9121 ANSON WAY, SUITE 100, RALEIGH, NC 27615
NORTH CAROLINA FIRM LICENSE C-1520**

SECTION 00 01 07

SEALS PAGE

PART 1 GENERAL

1.1 SUMMARY

A. Design Firm for New Hope Elementary School Building Enclosure Maintenance & Repair with Project Manual dated 04-10-2024:

1. REI Engineers, Inc., 9121 Anson Way, Suite 100, Raleigh, NC 27615.
2. North Carolina Firm License C-1520

Professional Engineer



Registered Waterproofing Consultant



END OF SECTION

SECTION 00 01 10

TABLE OF CONTENTS

PROCUREMENT AND CONTRACTING REQUIREMENTS

1.1 DIVISION 00 -- PROCUREMENT AND CONTRACTING REQUIREMENTS

- A. 00 01 07 - Seals Page
- B. 00 01 10 - Table of Contents
- C. 00 01 15 - List of Drawings
- D. 00 11 13 - Advertisement for Bids
- E. 00 21 13 - Instructions to Bidders
- F. 00 41 13 - Bid Form
- G. 00 43 13 - Bid Bond Form
- H. 00 43 39 - Minority Business Enterprise
- I. 00 52 13 - Standard Form of Agreement
- J. 00 60 00 - Project Forms
- K. 00 61 13.13 - Performance Bond Form
- L. 00 61 13.16 - Payment Bond Form
- M. 00 62 76.13 - Sales Tax Report
- N. 00 63 13 - Request for Interpretation
- O. 00 63 25 - Substitution Request Form
- P. 00 63 55 - Change Proposal Form
- Q. 00 65 36 - Contractor's Warranty
- R. 00 65 37 - Asbestos Free Warranty
- S. 00 72 13 - General Conditions of the Contract
- T. 00 73 00 - Supplementary Conditions

SPECIFICATIONS

2.1 DIVISION 01 -- GENERAL REQUIREMENTS

- A. 01 11 00 - Summary of Work
- B. 01 14 00 - Work Restrictions

- C. 01 21 00 - Allowances
- D. 01 22 00 - Unit Prices
- E. 01 23 00 - Alternates
- F. 01 25 00 - Substitution Procedures
- G. 01 26 00 - Contract Modification Procedures
- H. 01 29 00 - Payment Procedures
- I. 01 31 00 - Project Management and Coordination
- J. 01 33 00 - Submittal Procedures
- K. 01 40 00 - Quality Requirements
- L. 01 42 00 - Reference Standards
- M. 01 50 00 - Temporary Facilities and Controls
- N. 01 73 00 - Execution Requirements
- O. 01 74 00 - Cleaning and Waste Management
- P. 01 77 00 - Closeout Procedures

2.2 DIVISION 04 -- MASONRY

- A. 04 05 00 - Mortar and Grout
- B. 04 05 24 - Masonry Repointing
- C. 04 20 00 - Unit Masonry

2.3 DIVISION 07 -- THERMAL AND MOISTURE PROTECTION

- A. 07 13 26 - Self-Adhering Sheet Waterproofing
- B. 07 62 00 - Sheet Metal Flashing and Trim
- C. 07 92 00 - Elastomeric Joint Sealants

2.4 DIVISION 22 -- PLUMBING

- A. 22 14 00 - Storm Drainage

2.5 DIVISION 31 -- EARTHWORK

- A. 31 00 00 - Earthwork
- B. 31 23 17 - Trenching

2.6 DIVISION 32 -- EXTERIOR IMPROVEMENTS

A. 32 05 23 - Cement and Concrete for Exterior Improvements

END OF SECTION

SECTION 00 01 15
LIST OF DRAWINGS

PART 1 GENERAL

1.1 SUMMARY

A. The following drawings dated 04-10-2024 are included as part of the Contract Documents:

1. G-001 Cover
2. XW101 Site Plan
3. XW201 Typical Elevations
4. XW501 Details
5. XW502 Details

END OF SECTION

SECTION 00 11 13

ADVERTISEMENT FOR BIDS

PART 1 GENERAL

1.1 PROJECT INFORMATION

- A. Project Name: New Hope Elementary School Building Enclosure Maintenance & Repair
- B. Project Address: 1900 New Hope Church Road, Chapel Hill, North Carolina 27514
- C. Owner: Orange County Schools
- D. General Scope of Work: Perform general exterior building enclosure maintenance and repair; including below-grade stormwater rehabilitation, facade cleaning, replacement of joint sealants, repointing of masonry veneer, and replacement of broken/ deteriorated veneer units.

1.2 BIDS

- A. Sealed bids for the project will be received from bidders by the Owner at 200 E King Street, Hillsborough, North Carolina 27278 until 1:00 PM on 05-21-2024, at which time they will be publicly opened and read.

1.3 PROJECT DOCUMENTS

- A. Electronic project documents may be obtained from the Engineer, REI Engineers, Inc., 9121 Anson Way, Suite 100, Raleigh, NC 27615, David Krekelberg, dkrekelberg@reiengineers.com at no cost.

1.4 BIDDING REQUIREMENTS

- A. All bidders are hereby notified that they shall be properly licensed under the state laws governing their trades.
- B. Bid security in the amount equal to not less than 5% of the gross amount of the bid is required.
- C. A Performance Bond and Payment Bond in the amount of the contract is required.
- D. Submit questions to REI Engineers, Inc. in writing to the Project Manager's email address listed above no later than 5:00 PM at least 10 days prior to the bid due date.

1.5 PRE-BID MEETING

- A. A Pre-Bid Meeting is scheduled for 9:00 AM on 04-30-2024 at the project address listed above.
- B. Attendance is mandatory.

END OF SECTION

SECTION 00 21 13

INSTRUCTIONS TO BIDDERS

PART 1 GENERAL

1.1 DEFINITIONS

- A. The Bidding Documents consist of the Advertisement or Invitation to Bid, Instructions to Bidders, Bid Form, and other sample bidding and contract forms.
- B. The proposed Contract Documents consist of the Form of Agreement between the Owner and Contractor, Conditions of the Contract (General, Supplementary and other Conditions), Drawings, Specifications and Addenda issued prior to execution of the Contract.
- C. Definitions set forth in Section 00 72 13 - General Conditions of the Contract for Construction or in other Contract Documents are applicable to the Bidding Documents.
- D. Addenda are written or graphic instruments issued by the Engineer prior to the execution of the Contract which modify or interpret the Bidding Documents by additions, deletions, clarifications or corrections.
- E. A Bid is a complete and properly executed proposal to do the Work for the sums stipulated therein, submitted in accordance with the Bidding Documents.
- F. The Base Bid is the sum stated in the Bid for which the Bidder offers to perform the Work described in the Bidding Documents as the base, to which Work may be added or from which Work may be deleted for sums stated in Alternate Bids.
- G. An Alternate Bid (or Alternate) is an amount stated in the Bid to be added to or deducted from the amount of the Base Bid if the corresponding change in the Work, as described in the Bidding Documents, is accepted.
- H. A Unit Price is an amount stated in the Bid as a price per unit of measurement for materials, equipment or services or a portion of the Work as described in the Bidding Documents.
- I. A Bidder is a person or entity who submits a Bid and who meets the requirements set forth in the Bidding Documents.
- J. A Sub-bidder is a person or entity who submits a bid to a Bidder for materials, equipment or labor for a portion of the Work.

1.2 BIDS

- A. Submit Bid Form along with required enclosures in a sealed envelope, with the Bidder's name, license number, and project name written on the outside; place this sealed envelope in another envelope and deliver to the Owner at the address specified.
- B. Bids will be received until the date and time specified at which time they will be publicly opened and read.
- C. Fill in and sign the bid form correctly. Bids that show any omission, alterations of form, additions not called for, conditional Bids, or any irregularities of any kind may be rejected. If erasures are necessary and appear on the forms, each such erasure must be initialed by the person signing the proposal.

- D. Bids that are non-responsive or fail to follow the Instructions to Bidders may be rejected.
- E. No bid may be withdrawn after receipt of Bids for a period of 90 days.

1.3 ACCEPTANCE OF BID (AWARD)

- A. It is the intention of the Owner to award a contract for work under this project to the lowest responsible Bidder; however, in the interest of suitability to the need of the Owner and/or economy, equipment, materials and furnishings other than the lowest in price may be selected.
- B. The Owner reserves the right to reject any or all Bids, to accept any bid submitted, to waive any formalities, and to negotiate with the low Bidder or Bidders any changes considered necessary or desirable. The Owner reserves the right to reject any Bid when such rejection is in the interest of the Owner to reject the bid of the bidder who has previously failed to perform or to complete on time Contracts of a similar nature; and to reject the bid of a bidder who is not, in the opinion of the Engineer, in a position to perform the Contract.
- C. The Owner shall have the right to accept Alternates in any order or combination, unless otherwise specifically provided in the Bidding Documents, and to determine the low Bidder on the basis of the sum of the Base Bid and Alternates accepted. Alternates may be accepted at any time during the bid holding period.

1.4 PRE-BID MEETING

- A. Refer to the invitation or advertisement for bids for the date, time and location of the Pre-Bid Meeting.
- B. A Pre-Bid Meeting will be held for purposes of considering questions posed by Bidders. All interpretations and corrections to Contract Documents deriving from this meeting will be documented via Addendum.
- C. If the Bidder does not attend the Pre-Bid Meeting, it is the Bidder's responsibility to obtain the Pre-Bid Meeting Minutes and all Addenda.

1.5 DISQUALIFICATION

- A. The Owner reserves the right to disqualify Bids, before or after opening, upon evidence of collusion with intent to defraud or commit other illegal practices upon the part of the Bidder.

1.6 CONTRACTOR'S LICENSE

- A. All Bidders must have proper licenses for contractors as required by State Law. The Bidder's license number shall be listed on the bid form and on the outside of the inner sealed envelope in which the bid is submitted.

1.7 CONFLICT OF INTEREST

- A. Bidders must disclose in writing with their bid the name of any owner, officer, director, or agent who is also an employee of the Owner.
- B. Bidders must disclose in writing with their bid the name of any employee of the Owner who owns, directly or indirectly, an interest of 5 percent or more in the Bidder's firm or any of its branches or subsidiaries.

- C. By submitting a bid, the Bidder certifies that there is no relationship between the Bidder and any person or entity which is, or gives the appearance of, a conflict of interest related to this project.

1.8 NON-DISCRIMINATION

- A. The Bidder shall not discriminate against any individuals and will take proactive measures to assure compliance with all Federal and State requirements concerning fair employment, employment of people with disabilities, and concerning the treatment of all employees without regard to discrimination based upon age, race, color, religion, sex, national origin, or disability.

1.9 INTERPRETATION OF DRAWINGS AND SPECIFICATIONS

- A. Examine Drawings and Specifications and all Addenda or other revisions thereto and thoroughly familiarize himself with the detailed requirements thereof prior to submitting a proposal.
- B. Should a Bidder find discrepancies or ambiguities in, or omissions from the Specifications and Drawings bound herein, or should be in doubt as to their meaning, notify the Engineer in writing immediately. Engineer will issue an interpretation in the form of an addendum. This addendum will be forwarded to all Bidders of record.
- C. Addenda will be issued no later than four days prior to the date for receipt of Bids except an Addendum withdrawing the request for Bids or one which includes postponement of the date for receipt of Bids.
- D. Act promptly and allow sufficient time for a reply to be provided before the date established for submission of Bids.
- E. Acknowledge receipt of all addenda on the Bid Form.
- F. No oral interpretations will be made to any Bidder as to the meaning or intent of the Contract Documents or be effective to modify any of the provisions of the Contract Documents.

1.10 SUBSTITUTIONS

- A. References are made to certain specific products solely to denote the quality standard of the desired product and are not intended to restrict Bidders to a specific brand, make, manufacturer, or name. These products have been noted to assist in establishing material types and acceptable products. Equivalent products will be considered acceptable provided that the approval of the specific product has been given in writing by the Engineer.
- B. Written requests for substitution of equivalent products from prime bidders will be considered if received by the Engineer 10 calendar days prior to the bid opening.
- C. Identify the product or the fabrication or installation method to be replaced in each request. Include related specification sections and drawing number.
- D. Provide complete documentation on both the product specified and the proposed substitution including the following information as appropriate:
 - 1. Comparison of specified and proposed substitute product data, fabrication drawings, and installation procedures.
 - 2. Samples where applicable or requested.

3. Detailed comparison of significant qualities of the proposed substitution with those of the work specified.
 4. Coordination information, including a list of changes or modifications needed to other parts of the Work and to construction performed by the Owner and separate Contractors that will become necessary to accommodate the proposed substitution.
- E. Certification by the Bidder or manufacturer that the substitution proposed is equal to or better in every respect to that required by the Contract Documents, and that it will perform equal or superior to product specified in the application indicated. The Bidder waives any right to additional payment or time, which may subsequently become necessary because of the failure of the substitution to perform adequately.
- F. Engineer's Action: The Engineer may request additional information or documentation necessary for evaluation of the request. The Engineer will notify the Bidders of acceptance of the proposed substitution by means of an addendum to the bid documents. If the proposed substitute is accepted through an addendum use the product specified by name. Engineer's Substitution Approval during bidding and subsequent addendums does not void the Bidder's responsibility to submit the required shop drawings and comply with the other contract documents and requirements.

1.11 SITE INVESTIGATION

- A. Examine the site to determine the extent of work involved, size of work, etc., and the conditions under which the work must be staged and performed. Examine the grounds and buildings, utilities and roads and ascertain by any reasonable means conditions that will in any manner affect its work. Ask the Engineer for any additional information that he deems necessary to be fully informed as to exactly what is to be expected prior to submitting a proposal. The drawings have been prepared on the basis of surveys and inspections of the site and physical conditions at the site. This, however, does not relieve the Bidder of the necessity for fully informing itself as to the existing physical conditions. Secure field measurements for quantities upon which proposal is based. Carefully examine the existing conditions as compared to the Contract Documents.
- B. The submission of a bid will be construed as evidence that such an investigation has been made, and no subsequent allowance will be made in this connection on behalf of the bidder for any error or negligence.
- C. Upon arrival at the Project Site, immediately proceed to the main entrance/office and advise the administrative personnel of its presence and purpose. Sign the visitor's log, giving his name, his company and the time and date of the visit.
- D. Inspection of the work areas shall occur between the hours of 8:00 AM and 5:00 PM. No inspections will be conducted on Saturdays, Sundays, or holidays.

1.12 BID SECURITY

- A. Bid bond, deposit of cash or a certified check drawn on a bank or trust company insured by the FDIC in an amount equal to not less than 5% of the gross amount of the bid is required.

1.13 PERFORMANCE BOND AND LABOR AND MATERIALS PAYMENT BOND

- A. A Performance Bond and Payment Bond in the amount of the contract is required. Include the cost of providing Performance Bond and Payment Bond in the Base Bid.

1.14 PRIME CONTRACT

- A. Perform all work under a single prime contract.

1.15 PERMITS, FEES AND TAXES

- A. Secure and pay the costs of licenses, permits and fees for inspections required by City, County and/or State authorities; Social Security and other applicable Local, State and Federal Government taxes, and sales taxes. Include such costs in its bid.

1.16 SUBCONTRACTORS

- A. List names of subcontractors on the Bid Form. Identify work by the general, subcontractor or not applicable for each trade; utilize blank lines to list trades not provided in the table. Do not list suppliers. All blanks must be filled in. Failure to do so may result in bid being declared non-responsive. If there is more than one subcontractor per trade identified below, list all. If no subcontractors are to be utilized, indicate by signing at the appropriate place at the bottom of the table.
- B. A Bidder whose bid is accepted shall not substitute any person as subcontractor in the place of the subcontractor listed in the original bid, except if the listed subcontractor's bid is later determined by the successful Bidder to be nonresponsible or nonresponsive or the listed subcontractor refuses to enter into a contract for the complete performance of the bid work, or with the approval of the awarding authority, the Owner, for good cause shown by the successful Bidder.
- C. The terms, conditions, and requirements of each contract between the successful Bidder and a subcontractor performing work under a subdivision or branch of work listed in this subsection shall incorporate by reference the terms, conditions, and requirements of the contract between the contractor and the Owner.

1.17 FORM OF AGREEMENT

- A. The form of agreement between the Owner and Contractor to be entered into shall be the sample contained in Section 00 52 13 - Standard Form of Agreement.

1.18 BIDDER QUALIFICATIONS

- A. Bids will be accepted from Bidders who are regularly engaged in, and licensed to perform, the work they are bidding, which represents a significant portion of their total volume and who perform this work with workers regularly employed on their direct payrolls. Before a bid is considered for award, the Bidder may be requested by the Engineer to submit a statement of facts in detail as to its previous experience in performing similar or comparable work and of its business and technical organization and financial resources available to be used in contemplated work. The Bidder may also be required to submit a statement of facts in detail on his proposed subcontractors as to their previous experience and past performance in performing similar work or comparable work.

END OF SECTION

SECTION 00 41 13

BID FORM

PART 1 GENERAL

1.1 PROJECT AND ITS PARTIES

A. TO:

- 1. Mr. Patrick Florence
- 2. Orange County Schools
- 3. 200 E King Street,
- 4. Hillsborough, North Carolina 27278

B. PROJECT:

- 1. New Hope Elementary School Building Enclosure Maintenance & Repair
- 2. REI Project No. 023RAL-049

C. FROM:

- 1. Date: _____
- 2. Bidder: _____
- 3. Address: _____
- 4. Phone: _____ Email: _____
- 5. GC License : _____ Classification: _____ Limitation: _____

1.2 BASE BID

A. The undersigned, as bidder, hereby declares that the only person or persons interested in this bid as principal or principals is or are named herein and that no other person than herein mentioned has any interest in this bid or in the contract to be entered into; that this proposal is made without connection with any other person, company or parties making a bid or proposal; and that it is in all respects fair and in good faith without collusion or fraud. The Bidder further declares that he has examined the site of the work and the contract documents relative thereto dated 04-10-2024 as prepared by REI Engineers, Inc., and has read all special provisions furnished prior to the opening of bids; that he has satisfied himself relative to the work to be performed. The Bidder proposes and agrees if this bid is accepted to contract with the Owner in the form of contract specified, to furnish all necessary materials, equipment, machinery, tools apparatus, means of transportation and labor necessary to complete the construction of the project with a definite understanding that no money will be allowed for extra work except as set forth in the General Conditions and the Contract Documents, for the sum of:

- 1. Words: _____
- 2. Figures: _____.

1.3 ALTERNATES:

A. The undersigned agrees to perform alternative work as described in Section 01 23 00 - Alternates for the sums stated below resulting in additions to or deductions from the base bid stated above. Additions and deductions shall include any modifications of the Work or additional work that may be reasonably included as part of the alternative work. All alternative work is to be completed within the same timeframe as the base bid work. All alternates must be filled out. A zero or no entry after any alternate indicates no cost change to include that Alternate. Alternates may be accepted at any time during the bid holding period. The undersigned acknowledges that failure to complete all information requested in this section may result in the rejection of this bid.

1. Alternate No. 1: Replace glazing sealant at all exterior windows/ storefronts.

a. Words: _____

b. Figures: _____.

c. Select One: ___ Add or ___ Deduct

1.4 ALLOWANCES:

A. Include in the Base Bid the 35,000.00 Contingency Allowance.

B. Include in the Base Bid the following Quantity Allowances:

1. Repoint 12,000 LF of Deteriorated Mortar Joints.

2. Replace 250 EA of Deteriorated CMU Veneer Units.

3. Replace 2,300 SF of Concrete Sidewalk.

4. Repair 100 Abandoned Facade Penetrations.

1.5 UNIT PRICES:

A. Unit prices quoted and accepted shall apply throughout the life of the contract, except as otherwise specifically noted. Unit prices shall be applied, as appropriate, to compute the total value of changes in the scope of the work all in accordance with the contract documents.

1. Repoint Deteriorated Mortar Joint: _____ per LF

2. Replace Deteriorated CMU Veneer Unit: _____ per EA

3. Replace Concrete Sidewalk: _____ per SF

4. Repair Abandoned Facade Penetration: _____ per EA

1.6 BID HOLDING TIME AND ACCEPTANCE:

A. The undersigned hereby agrees that this bid may not be revoked or withdrawn after the time set for the opening of bids but shall remain open during the bid holding period as specified in Section 00 21 13 - Instructions to Bidders.

1.7 SCHEDULE OF COMPLETION:

- A. The undersigned understands that time is of the essence and agrees to the Contract Time and liquidated damages as indicated in General Conditions of the Contract for Construction and Supplementary Conditions apply to this Work. The undersigned hereby agrees to commence work on this project within 30 days following receipt of an Executed Agreement between the Owner and Contractor. Date of commencement will be established in a Notice to Proceed issued to the Contractor. Complete work under the Base Bid and all alternates accepted within 120 calendar days from the date of commencement.
 - 1. Construction is anticipated to begin June 12, 2024. See Section 01 14 00 "Work Restrictions" for additional information.
 - 2. Applicable liquidated damages shall be as stated in the Supplementary Conditions.

1.8 ADDENDUM:

- A. Addendum received and used in computing bid:
 - 1. Addendum No. 1: _____
 - 2. Addendum No. 2: _____

1.9 SUBCONTRACTORS:

- A. Fill out all blanks on the list below listing all subcontractors. Identify work by the general, subcontractor or not applicable for each trade; utilize blank lines to list trades not provided. Do not list suppliers. All blanks must be filled in. Failure to do so may result in bid being declared non-responsive. If there is more than one subcontractor per trade identified below, list all. If no subcontractors are to be utilized, indicate by signing at the appropriate place at the bottom of the table.
 - 1. Trade: General Contractor: _____
 - 2. Trade: Sheet Metal Contractor: _____
 - 3. Trade: Waterproofing Contractor: _____
 - 4. Trade: Plumbing Contractor: _____
 - 5. Trade: Masonry Contractor: _____
 - 6. Trade: Concrete Contractor: _____
 - 7. Trade: Utility Locate Contractor: _____
 - 8. Trade: Waste Disposal Contractor: _____
 - 9. Trade: _____ Contractor: _____
 - 10. Trade: _____ Contractor: _____
 - 11. Trade: _____ Contractor: _____
 - 12. We do not plan to use subcontractors: _____ Signed

1.10 ENCLOSURES:

- A. Provide the following enclosures with submitted bid:
 - 1. Bid Bond
 - 2. Section 00 43 39 - Minority Business Enterprise Submittals
 - a. MWSBE Identification Form
 - b. State of North Carolina Affidavit A - Listing of the Good Faith Effort or Affidavit B - Intent to Perform Contract with Own Workforce.

1.11 SUBMITTED BY:

- A. Contractor Name: _____
- B. Authorized Signing Officer Name: _____
- C. Authorized Signing Office Title: _____
- D. Signature: _____
- E. Respectfully submitted this _____ day of _____, 20____

1.12 NOTARIZED BY:

- A. I, _____ print name , a Notary Public for _____ County of _____ State , do hereby certify that _____ officer listed above personally appeared before me this day and acknowledged the due execution of the foregoing instrument. Witness my hand and official seal, this _____ day of _____, 20 ____ . My commission expires ____ of _____, 20 ____ .
- B. Signed: _____

OFFICIAL SEAL

END OF SECTION

SECTION 00 43 13

BID BOND FORM

PART 1 GENERAL

1.1 SUMMARY

A. Section Includes:

1. Owner's required Bid Bond Form attached to this section.

1.2 RELATED DOCUMENTS

A. Drawings and general provisions of the Contract, including General and Supplementary Conditions and Specification Sections apply to this Section.

1.3 BID SECURITY

- A. File a bid bond in the amount equal to not less than 5% of the gross amount of the bid executed in accordance with and conditioned as prescribed by GS 143-129, as amended by Chapter 1104 of the North Carolina Public Laws of 1951.
- B. In lieu thereof, each bid may be accompanied by a deposit of cash or a certified check drawn on a bank or trust company insured by the Federal Deposit Insurance Corporation (FDIC) in an amount equal to not less than 5% of the gross amount of the bid.
- C. Bid Bond shall be signed by the Bidder and notarized.
- D. If the successful Bidder fails to execute the contract within 10 days after award, the above deposit will be retained by the Owner on the bid bond executed on liquidated damages.

FORM OF BID BOND

KNOW ALL MEN BY THESE PRESENTS THAT _____ as principal, and _____, as surety, who is duly licensed to act as surety in North Carolina, are held and firmly bound unto Orange County, North Carolina through _____ as obligee, in the penal sum of _____ DOLLARS, lawful money of the United States of America, for the payment of which, well and truly to be made, we bind ourselves, our heirs, executors, administrators, successors and assigns, jointly and severally, firmly by these presents.

Signed, sealed and dated this _____ day of _____, 20__.

WHEREAS, the said principal is herewith submitting proposal for and the principal desires to file this bid bond in lieu of making the cash deposit as required by G.S. 143-129.

NOW, THEREFORE, THE CONDITION OF THE ABOVE OBLIGATION is such, that if the principal shall be awarded the contract for which the bid is submitted and shall execute the contract and give bond for the faithful performance thereof within ten days after the award of same to the principal, then this obligation shall be null and void; but if the principal fails to so execute such contract and give performance bond as required by G.S. 143-129, the surety shall, upon demand, forthwith pay to the obligee the amount set forth in the first paragraph hereof. Provided further, that the bid may be withdrawn as provided by G.S. 143-129.1

_____(SEAL)
_____(SEAL)
_____(SEAL)
_____(SEAL)
_____(SEAL)

SECTION 00 43 39

MINORITY BUSINESS ENTERPRISE

PART 1 GENERAL

1.1 SUMMARY

A. Section Includes:

1. Owner's required Minority, Women and Small Business Enterprise Program.

1.2 RELATED DOCUMENTS

A. Drawings and general provisions of the Contract, including General and Supplementary Conditions and Specification Sections apply to this Section.

GUIDELINES FOR RECRUITMENT AND SELECTION OF MINORITY BUSINESSES FOR PARTICIPATION IN STATE CONSTRUCTION CONTRACTS

In accordance with G.S. 143-128.2 (effective January 1, 2002) these guidelines establish goals for minority participation in single-prime bidding, separate-prime bidding, construction manager at risk, and alternative contracting methods, on State construction projects in the amount of \$300,000 or more. The legislation provides that the State shall have a verifiable ten percent (10%) goal for participation by minority businesses in the total value of work for each project for which a contract or contracts are awarded. These requirements are published to accomplish that end.

SECTION A: INTENT

It is the intent of these guidelines that the State of North Carolina, as awarding authority for construction projects, and the contractors and subcontractors performing the construction contracts awarded shall cooperate and in good faith do all things legal, proper and reasonable to achieve the statutory goal of ten percent (10%) for participation by minority businesses in each construction project as mandated by GS 143-128.2. Nothing in these guidelines shall be construed to require contractors or awarding authorities to award contracts or subcontracts to or to make purchases of materials or equipment from minority- business contractors or minority-business subcontractors who do not submit the lowest responsible, responsive bid or bids.

SECTION B: DEFINITIONS

1. Minority - a person who is a citizen or lawful permanent resident of the United States and who is:
 - a. Black, that is, a person having origins in any of the black racial groups in Africa;
 - b. Hispanic, that is, a person of Spanish or Portuguese culture with origins in Mexico, South or Central America, or the Caribbean Islands, regardless of race;
 - c. Asian American, that is, a person having origins in any of the original peoples of the Far East, Southeast Asia and Asia, the Indian subcontinent, the Pacific Islands;
 - d. American Indian, that is, a person having origins in any of the original peoples of North America; or
 - e. Female
2. Minority Business - means a business:
 - a. In which at least fifty-one percent (51%) is owned by one or more minority persons, or in the case of a corporation, in which at least fifty-one percent (51%) of the stock is owned by one or more minority persons or socially and economically disadvantaged individuals; and
 - b. Of which the management and daily business operations are controlled by one or more of the minority persons or socially and economically disadvantaged individuals who own it.
3. Socially and economically disadvantaged individual - means the same as defined in 15 U.S.C. 637. "Socially disadvantaged individuals are those who have been subjected to racial or ethnic prejudice or cultural bias because of their identity as a member of a group without regard to their individual qualities". "Economically disadvantaged individuals are those socially disadvantaged individuals whose ability to compete in the free enterprise system has been impaired due to diminished capital and credit opportunities as compared to others in the same business area who are not socially disadvantaged".
4. Public Entity - means State and all public subdivisions and local governmental units.
5. Owner - The State of North Carolina, through the Agency/Institution named in the contract.
6. Designer - Any person, firm, partnership, or corporation, which has contracted with the State of North Carolina to perform architectural or engineering, work.
7. Bidder - Any person, firm, partnership, corporation, association, or joint venture seeking to be

awarded a public contract or subcontract.

8. Contract - A mutually binding legal relationship or any modification thereof obligating the seller to furnish equipment, materials or services, including construction, and obligating the buyer to pay for them.
9. Contractor - Any person, firm, partnership, corporation, association, or joint venture which has contracted with the State of North Carolina to perform construction work or repair.
10. Subcontractor - A firm under contract with the prime contractor or construction manager at risk for supplying materials or labor and materials and/or installation. The subcontractor may or may not provide materials in his subcontract.

SECTION C: RESPONSIBILITIES

1. Office for Historically Underutilized Businesses, Department of Administration (hereinafter referred to as HUB Office).

The HUB Office has established a program, which allows interested persons or businesses qualifying as a minority business under G.S. 143-128.2, to obtain certification in the State of North Carolina procurement system. The information provided by the minority businesses will be used by the HUB Office to:

- a. Identify those areas of work for which there are minority businesses, as requested.
- b. Make available to interested parties a list of prospective minority business contractors and subcontractors.
- c. Assist in the determination of technical assistance needed by minority business contractors.

In addition to being responsible for the certification/verification of minority businesses that want to participate in the State construction program, the HUB Office will:

- (1) Maintain a current list of minority businesses. The list shall include the areas of work in which each minority business is interested.
- (2) Inform minority businesses on how to identify and obtain contracting and subcontracting opportunities through the State Construction Office and other public entities.
- (3) Inform minority businesses of the contracting and subcontracting process for public construction building projects.
- (4) Work with the North Carolina trade and professional organizations to improve the ability of minority businesses to compete in the State construction projects.
- (5) The HUB Office also oversees the minority business program by:
 - a. Monitoring compliance with the program requirements.
 - b. Assisting in the implementation of training and technical assistance programs.
 - c. Identifying and implementing outreach efforts to increase the utilization of minority businesses.
 - d. Reporting the results of minority business utilization to the Secretary of the Department of Administration, the Governor, and the General Assembly.

2. State Construction Office

The State Construction Office will be responsible for the following:

- a. Furnish to the HUB Office a minimum of twenty-one days prior to the bid opening the following:
 - (1) Project description and location;
 - (2) Locations where bidding documents may be reviewed;
 - (3) Name of a representative of the owner who can be contacted during the advertising period to advise who the prospective bidders are;
 - (4) Date, time and location of the bid opening.
 - (5) Date, time and location of prebid conference, if scheduled.

- b. Attending scheduled prebid conference, if necessary, to clarify requirements of the general statutes regarding minority-business participation, including the bidders' responsibilities.
- c. Reviewing the apparent low bidders' statutory compliance with the requirements listed in the proposal, that must be complied with, if the bid is to be considered as responsive, prior to award of contracts. The State reserves the right to reject any or all bids and to waive informalities.
- d. Reviewing of minority business requirements at Preconstruction conference.
- e. Monitoring of contractors' compliance with minority business requirements in the contract documents during construction.
- f. Provide statistical data and required reports to the HUB Office.
- g. Resolve any protest and disputes arising after implementation of the plan, in conjunction with the HUB Office.

3. Owner

Before awarding a contract, owner shall do the following:

- a. Develop and implement a minority business participation outreach plan to identify minority businesses that can perform public building projects and to implement outreach efforts to encourage minority business participation in these projects to include education, recruitment, and interaction between minority businesses and non-minority businesses.
- b. Attend the scheduled prebid conference.
- c. At least 10 days prior to the scheduled day of bid opening, notify minority businesses that have requested notices from the public entity for public construction or repair work and minority businesses that otherwise indicated to the Office for Historically Underutilized Businesses an interest in the type of work being bid or the potential contracting opportunities listed in the proposal. The notification shall include the following:
 - 1. A description of the work for which the bid is being solicited.
 - 2. The date, time, and location where bids are to be submitted.
 - 3. The name of the individual within the owner's organization who will be available to answer questions about the project.
 - 4. Where bid documents may be reviewed.
 - 5. Any special requirements that may exist.
- d. Utilize other media, as appropriate, likely to inform potential minority businesses of the bid being sought.
- e. Maintain documentation of any contacts, correspondence, or conversation with minority business firms made in an attempt to meet the goals.
- f. Review, jointly with the designer, all requirements of G.S. 143-128.2(c) and G.S. 143-128.2(f) – (i.e. bidders' proposals for identification of the minority businesses that will be utilized with corresponding total dollar value of the bid and affidavit listing good faith efforts, or affidavit of self-performance of work, if the contractor will perform work under contract by its own workforce) - prior to recommendation of award to the State Construction Office.
- g. Evaluate documentation to determine good faith effort has been achieved for minority business utilization prior to recommendation of award to State Construction Office.
- h. Review prime contractors' pay applications for compliance with minority business utilization commitments prior to payment.
- i. Make documentation showing evidence of implementation of Owner's responsibilities available for review by State Construction Office and HUB Office, upon request

4. Designer

Under the single-prime bidding, separate prime bidding, construction manager at risk, or alternative contracting method, the designer will:

- a. Attend the scheduled prebid conference to explain minority business requirements to the prospective bidders.
- b. Assist the owner to identify and notify prospective minority business prime and subcontractors

of potential contracting opportunities.

- c. Maintain documentation of any contacts, correspondence, or conversation with minority business firms made in an attempt to meet the goals.
- d. Review jointly with the owner, all requirements of G.S. 143-128.2(c) and G.S.143-128.2(f) – (i.e. bidders’ proposals for identification of the minority businesses that will be utilized with corresponding total dollar value of the bid and affidavit listing Good Faith Efforts, or affidavit of self-performance of work, if the contractor will perform work under contract by its own workforce) - prior to recommendation of award.
- e. During construction phase of the project, review “MBE Documentation for Contract Payment” – (Appendix E) for compliance with minority business utilization commitments. Submit Appendix E form with monthly pay applications to the owner and forward copies to the State Construction Office.
- f. Make documentation showing evidence of implementation of Designer’s responsibilities available for review by State Construction Office and HUB Office, upon request.

5. Prime Contractor(s), CM at Risk, and Its First-Tier Subcontractors

Under the single-prime bidding, the separate-prime bidding, construction manager at risk and alternative contracting methods, contractor(s) will:

- a. Attend the scheduled prebid conference.
- b. Identify or determine those work areas of a subcontract where minority businesses may have an interest in performing subcontract work.
- c. At least ten (10) days prior to the scheduled day of bid opening, notify minority businesses of potential subcontracting opportunities listed in the proposal. The notification will include the following:
 - (1) A description of the work for which the subbid is being solicited.
 - (2) The date, time and location where subbids are to be submitted.
 - (3) The name of the individual within the company who will be available to answer questions about the project.
 - (4) Where bid documents may be reviewed.
 - (5) Any special requirements that may exist, such as insurance, licenses, bonds and financial arrangements.

If there are more than three (3) minority businesses in the general locality of the project who offer similar contracting or subcontracting services in the specific trade, the contractor(s) shall notify three (3), but may contact more, if the contractor(s) so desires.

- d. During the bidding process, comply with the contractor(s) requirements listed in the proposal for minority participation.
- e. Identify on the bid, the minority businesses that will be utilized on the project with corresponding total dollar value of the bid and affidavit listing good faith efforts as required by G.S. 143-128.2(c) and G.S. 143-128.2(f).
- f. Make documentation showing evidence of implementation of PM, CM-at-Risk and First-Tier Subcontractor responsibilities available for review by State Construction Office and HUB Office, upon request.
- g. Upon being named the apparent low bidder, the Bidder shall provide one of the following: (1) an affidavit (Affidavit C) that includes a description of the portion of work to be executed by minority businesses, expressed as a percentage of the total contract price, which is equal to or more than the applicable goal; (2) if the percentage is not equal to the applicable goal, then documentation of all good faith efforts taken to meet the goal. Failure to comply with these requirements is grounds for rejection of the bid and award to the next lowest responsible and responsive bidder.
- h. The contractor(s) shall identify the name(s) of minority business subcontractor(s) and corresponding dollar amount of work on the schedule of values. The schedule of values shall be provided as required in Article 31 of the General Conditions of the Contract to facilitate payments to the subcontractors.
- i. The contractor(s) shall submit with each monthly pay request(s) and final payment(s), “MBE

Documentation for Contract Payment” – (Appendix E), for designer’s review.

- j. During the construction of a project, at any time, if it becomes necessary to replace a minority business subcontractor, immediately advise the owner, State Construction Office, and the Director of the HUB Office in writing, of the circumstances involved. The prime contractor shall make a good faith effort to replace a minority business subcontractor with another minority business subcontractor.
- k. If during the construction of a project additional subcontracting opportunities become available, make a good faith effort to solicit subbids from minority businesses.
- l. It is the intent of these requirements apply to all contractors performing as prime contractor and first tier subcontractor under construction manager at risk on state projects.

6. **Minority Business Responsibilities**

While minority businesses are not required to become certified in order to participate in the State construction projects, it is recommended that they become certified and should take advantage of the appropriate technical assistance that is made available. In addition, minority businesses who are contacted by owners or bidders must respond promptly whether or not they wish to submit a bid.

SECTION 4: DISPUTE PROCEDURES

It is the policy of this state that disputes that involves a person's rights, duties or privileges, should be settled through informal procedures. To that end, minority business disputes arising under these guidelines should be resolved as governed under G.S. 143-128(g).

SECTION 5: These guidelines shall apply upon promulgation on state construction projects. Copies of these guidelines may be obtained from the Department of Administration, State Construction Office, (physical address) 301 North Wilmington Street, Suite 450, NC Education Building, Raleigh, North Carolina, 27601-2827, (mail address) 1307 Mail Service Center, Raleigh, North Carolina, 27699-1307, phone (919) 807-4100, Website: www.nc-sco.com

SECTION 6: In addition to these guidelines, there will be issued with each construction bid package provisions for contractual compliance providing minority business participation in the state construction program.

MINORITY BUSINESS CONTRACT PROVISIONS(CONSTRUCTION)

APPLICATION:

The **Guidelines for Recruitment and Selection of Minority Businesses for Participation in State Construction Contracts** are hereby made a part of these contract documents. These guidelines shall apply to all contractors regardless of ownership. Copies of these guidelines may be obtained from the Department of Administration, State Construction Office, (physical address) 301 North Wilmington Street, Suite 450, NC Education Building, Raleigh, North Carolina, 27601-2827, (mail address) 1307 Mail Service Center, Raleigh, North Carolina, 27699-1307, phone (919) 807-4100, Website: <http://www.nc-sco.com>

MINORITY BUSINESS SUBCONTRACT GOALS:

The goals for participation by minority firms as subcontractors on this project have been set at 10%.

The bidder must identify on its bid, the minority businesses that will be utilized on the project with corresponding total dollar value of the bid and affidavit (Affidavit A) listing good faith efforts **or** affidavit (Affidavit B) of self-performance of work, if the bidder will perform work under contract by its own workforce, as required by G.S. 143-128.2(c) and G.S. 143-128.2(f).

The lowest responsible, responsive bidder must provide Affidavit C, that includes a description of the portion of work to be executed by minority businesses, expressed as a percentage of the total contract price, which is equal to or more than the applicable goal.

OR

Provide Affidavit D, that includes a description of the portion of work to be executed by minority businesses, expressed as a percentage of the total contract price, **with documentation of Good Faith Effort, if the percentage is not equal to the applicable goal.**

OR

Provide Affidavit B, which includes sufficient information for the State to determine that the bidder does not customarily subcontract work on this type project.

The above information must be provided as required. Failure to submit these documents is grounds for rejection of the bid.

MINIMUM COMPLIANCE REQUIREMENTS:

All written statements, affidavits or intentions made by the Bidder shall become a part of the agreement between the Contractor and the State for performance of this contract. Failure to comply with any of these statements, affidavits or intentions, or with the minority business Guidelines shall constitute a breach of the contract. A finding by the State that any information submitted either prior to award of the contract or during the performance of the contract is inaccurate, false or incomplete, shall also constitute a breach of the contract. Any such breach may result in termination of the contract in accordance with the termination provisions contained in the contract. It shall be solely at the option of the State whether to terminate the contract for breach.

In determining whether a contractor has made Good Faith Efforts, the State will evaluate all efforts made by the Contractor and will determine compliance in regard to quantity, intensity, and results of these efforts. Good Faith Efforts include:

- (1) Contacting minority businesses that reasonably could have been expected to submit a quote and that were known to the contractor or available on State or local government maintained lists at least 10 days before the bid or proposal date and notifying them of the nature and scope of the work to be performed.
- (2) Making the construction plans, specifications and requirements available for review by prospective minority businesses or providing these documents to them at least 10 days before the bid or proposals are due.
- (3) Breaking down or combining elements of work into economically feasible units to facilitate minority participation.
- (4) Working with minority trade, community, or contractor organizations identified by the Office for Historically Underutilized Businesses and included in the bid documents that provide assistance in recruitment of minority businesses.
- (5) Attending any prebid meetings scheduled by the public owner.
- (6) Providing assistance in getting required bonding or insurance or providing alternatives to bonding or insurance for subcontractors.
- (7) Negotiating in good faith with interested minority businesses and not rejecting them as unqualified without sound reasons based on their capabilities. Any rejection of a minority business based on lack of qualification should have the reasons documented in writing.
- (8) Providing assistance to an otherwise qualified minority business in need of equipment, loan capital, lines of credit, or joint pay agreements to secure loans, supplies, or letters of credit, including waiving credit that is ordinarily required. Assisting minority businesses in obtaining the same unit pricing with the bidder's suppliers in order to help minority businesses in establishing credit.
- (9) Negotiating joint venture and partnership arrangements with minority businesses in order to increase opportunities for minority business participation on a public construction or repair project when possible.
- (10) Providing quick pay agreements and policies to enable minority contractors and suppliers to meet cash-flow demands.

APPENDIX E

MBE DOCUMENTATION FOR CONTRACT PAYMENTS

Prime Contractor/Architect: _____

Address & Phone: _____

Project Name: _____

Pay Application #: _____ Period: _____

The following is a list of payments made to Minority Business Enterprises on this project for the above- mentioned period.

MBE FIRM NAME	* INDICATE TYPE OF MBE	AMOUNT PAID THIS MONTH	TOTAL PAYMENTS TO DATE	TOTAL AMOUNT COMMITTED

*Minority categories: Black, African American (B), Hispanic (H), Asian American (A), American Indian (I), Female (F), Social and Economically Disadvantage (D)

Date: _____ Approved/Certified By: _____

Name

Title

Signature

SUBMIT WITH EACH PAY REQUEST & FINAL PAYMENT

(Revised 3/14/2003)

Identification of HUB Certified/Minority Business Participation

I, _____,
 (Name of Bidder)

do hereby certify that on this project, we will use the following HUB Certified/ minority business as construction subcontractors, vendors, suppliers or providers of professional services.

Firm Name, Address and Phone #	Work Type	*Minority Category	**HUB Certified (Y/N)

*Minority categories: Black, African American (**B**), Hispanic (**H**), Asian American (**A**) American Indian (**I**), Female (**F**) Socially and Economically Disadvantaged (**D**)

** HUB Certification with the state HUB Office required to be counted toward state participation goals.

The total value of minority business contracting will be (\$) _____.

State of North Carolina - AFFIDAVIT A - Listing of Good Faith Efforts

County of _____

(Name of Bidder)

Affidavit of _____

I have made a good faith effort to comply under the following areas checked:

Bidders must earn at least 50 points from the good faith efforts listed for their bid to be considered responsive. (1 NC Administrative Code 30 I.0101)

- 1 – (10 pts)** Contacted minority businesses that reasonably could have been expected to submit a quote and that were known to the contractor, or available on State or local government maintained lists, at least 10 days before the bid date and notified them of the nature and scope of the work to be performed.
- 2 --(10 pts)** Made the construction plans, specifications and requirements available for review by prospective minority businesses, or providing these documents to them at least 10 days before the bids are due.
- 3 – (15 pts)** Broken down or combined elements of work into economically feasible units to facilitate minority participation.
- 4 – (10 pts)** Worked with minority trade, community, or contractor organizations identified by the Office of Historically Underutilized Businesses and included in the bid documents that provide assistance in recruitment of minority businesses.
- 5 – (10 pts)** Attended prebid meetings scheduled by the public owner.
- 6 – (20 pts)** Provided assistance in getting required bonding or insurance or provided alternatives to bonding or insurance for subcontractors.
- 7 – (15 pts)** Negotiated in good faith with interested minority businesses and did not reject them as unqualified without sound reasons based on their capabilities. Any rejection of a minority business based on lack of qualification should have the reasons documented in writing.
- 8 – (25 pts)** Provided assistance to an otherwise qualified minority business in need of equipment, loan capital, lines of credit, or joint pay agreements to secure loans, supplies, or letters of credit, including waiving credit that is ordinarily required. Assisted minority businesses in obtaining the same unit pricing with the bidder's suppliers in order to help minority businesses in establishing credit.
- 9 – (20 pts)** Negotiated joint venture and partnership arrangements with minority businesses in order to increase opportunities for minority business participation on a public construction or repair project when possible.
- 10 - (20 pts)** Provided quick pay agreements and policies to enable minority contractors and suppliers to meet cash-flow demands.

The undersigned, if apparent low bidder, will enter into a formal agreement with the firms listed in the Identification of Minority Business Participation schedule conditional upon scope of contract to be executed with the Owner. Substitution of contractors must be in accordance with GS143-128.2(d) Failure to abide by this statutory provision will constitute a breach of the contract.

The undersigned hereby certifies that he or she has read the terms of the minority business commitment and is authorized to bind the bidder to the commitment herein set forth.

Date: _____ Name of Authorized Officer: _____
Signature: _____
Title: _____

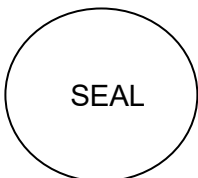

State of _____, County of _____
Subscribed and sworn to before me this _____ day of _____ 20____
Notary Public _____
My commission expires _____

State of North Carolina - AFFIDAVIT B - Intent to Perform Contract with Own Workforce.

County of _____

Affidavit of _____

(Name of Bidder)

I hereby certify that it is our intent to perform 100% of the work required for the _____

_____ contract.

(Name of Project)

In making this certification, the Bidder states that the Bidder does not customarily subcontract elements of this type project, and normally performs and has the capability to perform and will perform all elements of the work on this project with his/her own current work forces; and

The Bidder agrees to provide any additional information or documentation requested by the owner in support of the above statement. The Bidder agrees to make a Good Faith Effort to utilize minority suppliers where possible.

The undersigned hereby certifies that he or she has read this certification and is authorized to bind the Bidder to the commitments herein contained.

Date: _____ Name of Authorized Officer: _____

Signature: _____

Title: _____

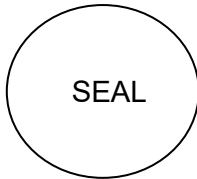

State of _____, County of _____

Subscribed and sworn to before me this _____ day of _____ 20____

Notary Public _____

My commission expires _____

State of North Carolina - AFFIDAVIT C - Portion of the Work to be Performed by HUB Certified/Minority Businesses

County of _____

(Note this form is to be submitted only by the apparent lowest responsible, responsive bidder.)

If the portion of the work to be executed by HUB certified/minority businesses as defined in GS143-128.2(g) and 128.4(a),(b),(e) is equal to or greater than 10% of the bidders total contract price, then the bidder must complete this affidavit.
 This affidavit shall be provided by the apparent lowest responsible, responsive bidder within **72 hours** after notification of being low bidder.

Affidavit of _____ I do hereby certify that on the
 (Name of Bidder)

 (Project Name)
 Project ID# _____ Amount of Bid \$ _____

I will expend a minimum of _____% of the total dollar amount of the contract with minority business enterprises. Minority businesses will be employed as construction subcontractors, vendors, suppliers or providers of professional services. Such work will be subcontracted to the following firms listed below.

Attach additional sheets if required

Name and Phone Number	*Minority Category	**HUB Certified Y/N	Work Description	Dollar Value

*Minority categories: Black, African American (**B**), Hispanic (**H**), Asian American (**A**) American Indian (**I**), Female (**F**) Socially and Economically Disadvantaged (**D**)

**** HUB Certification with the state HUB Office required to be counted toward state participation goals.**

Pursuant to GS143-128.2(d), the undersigned will enter into a formal agreement with Minority Firms for work listed in this schedule conditional upon execution of a contract with the Owner. Failure to fulfill this commitment may constitute a breach of the contract.

The undersigned hereby certifies that he or she has read the terms of this commitment and is authorized to bind the bidder to the commitment herein set forth.

Date: _____ Name of Authorized Officer: _____

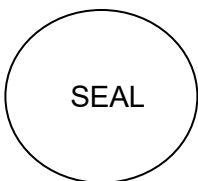

Signature: _____

Title: _____

State of _____, County of _____

Subscribed and sworn to before me this _____ day of _____ 20____

Notary Public _____

My commission expires _____

State of North Carolina - AFFIDAVIT D - Good Faith Efforts

County of _____

(Note this form is to be submitted only by the apparent lowest responsible, responsive bidder.)

If the goal of 10% participation by HUB Certified/ minority business **is not** achieved, the Bidder shall provide the following documentation to the Owner of his good faith efforts:

Affidavit of _____ I do hereby certify that on the _____
(Name of Bidder)

Project ID# _____ (Project Name) Amount of Bid \$ _____

I will expend a minimum of _____% of the total dollar amount of the contract with HUB certified/ minority business enterprises. Minority businesses will be employed as construction subcontractors, vendors, suppliers or providers of professional services. Such work will be subcontracted to the following firms listed below. (Attach additional sheets if required)

Name and Phone Number	*Minority Category	**HUB Certified Y/N	Work Description	Dollar Value

*Minority categories: Black, African American (**B**), Hispanic (**H**), Asian American (**A**) American Indian (**I**), Female (**F**) Socially and Economically Disadvantaged (**D**)

**** HUB Certification with the state HUB Office required to be counted toward state participation goals.**

Examples of documentation that may be required to demonstrate the Bidder's good faith efforts to meet the goals set forth in these provisions include, but are not necessarily limited to, the following:

- A. Copies of solicitations for quotes to at least three (3) minority business firms from the source list provided by the State for each subcontract to be let under this contract (if 3 or more firms are shown on the source list). Each solicitation shall contain a specific description of the work to be subcontracted, location where bid documents can be reviewed, representative of the Prime Bidder to contact, and location, date and time when quotes must be received.
- B. Copies of quotes or responses received from each firm responding to the solicitation.
- C. A telephone log of follow-up calls to each firm sent a solicitation.
- D. For subcontracts where a minority business firm is not considered the lowest responsible sub-bidder, copies of quotes received from all firms submitting quotes for that particular subcontract.
- E. Documentation of any contacts or correspondence to minority business, community, or contractor organizations in an attempt to meet the goal.
- F. Copy of pre-bid roster
- G. Letter documenting efforts to provide assistance in obtaining required bonding or insurance for minority business.
- H. Letter detailing reasons for rejection of minority business due to lack of qualification.
- I. Letter documenting proposed assistance offered to minority business in need of equipment, loan capital, lines of credit, or joint pay agreements to secure loans, supplies, or letter of credit, including waiving credit that is ordinarily required.

Failure to provide the documentation as listed in these provisions may result in rejection of the bid and award to the next lowest responsible and responsive bidder.

Pursuant to GS143-128.2(d), the undersigned will enter into a formal agreement with Minority Firms for work listed in this schedule conditional upon execution of a contract with the Owner. Failure to fulfill this commitment may constitute a breach of the contract.

The undersigned hereby certifies that he or she has read the terms of this commitment and is authorized to bind the bidder to the commitment herein set forth.

Date: _____ Name of Authorized Officer: _____

Signature: _____

Title: _____

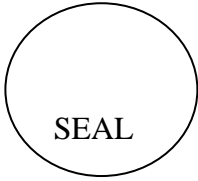

State of _____, County of _____

Subscribed and sworn to before me this _____ day of _____ 20____

Notary Public _____

My commission expires _____

APPENDIX E

MBE DOCUMENTATION FOR CONTRACT PAYMENTS

Prime Contractor/Architect: _____

Address & Phone: _____

Project Name: _____

Pay Application #: _____ Period: _____

The following is a list of payments made to Minority Business Enterprises on this project for the above-mentioned period.

MBE FIRM NAME	* INDICATE TYPE OF MBE	AMOUNT TO BE PAID	TOTAL PAYMENTS TO DATE	TOTAL AMOUNT COMMITTED

*Minority categories: Black, African American (B), Hispanic (H), Asian American (A), American Indian (I), Female (F), Social and Economically Disadvantage (D)

Date: _____ Approved/Certified By: _____

Name

Title

Signature

SUBMIT WITH EACH PAY REQUEST & FINAL PAYMENT

SECTION 00 43 39

MINORITY BUSINESS ENTERPRISE

PART 1 GENERAL

1.1 SUMMARY

A. Section Includes:

1. Owner's required Minority, Women and Small Business Enterprise Program.

1.2 RELATED DOCUMENTS

A. Drawings and general provisions of the Contract, including General and Supplementary Conditions and Specification Sections apply to this Section.

SECTION 00 52 13

STANDARD FORM OF AGREEMENT

PART 1 GENERAL

1.1 SUMMARY

A. Section Includes:

1. Owner's Standard Form of Agreement

1.2 RELATED DOCUMENTS

A. Drawings and general provisions of the Contract, including General and Supplementary Conditions and Specification Sections apply to this Section.

OWNER-CONTRACTOR AGREEMENT

(SAMPLE)

PROJECT NUMBER: 023RAL-049

SCHOOL NAME: **New Hope Elementary School**

THIS AGREEMENT, in four (4) copies, made this () day of _____, Two Thousand and Twenty by and between _____ (herein referred to as the "Owner"), whose mailing address is _____ and _____. (herein referred to as the "Contractor"), whose mailing address is _____. Correspondence, submittals, and notices relating to or required under this Contract shall be sent in writing to the above addresses; unless either party is notified in writing by the other, of a change in address.

WITNESSETH:

WHEREAS, it is the intent of the Owner to obtain the services of the Contractor in connection with the new construction of **New Hope Elementary School Building Enclosure Maintenance & Repair** (hereinafter referred to as the "Project" or the "Work"); and

WHEREAS, the Contractor desires to perform such construction in accordance with the terms and conditions of this Agreement,

NOW, THEREFORE, in consideration of the promises made herein and other good and valuable consideration, the following terms and conditions are hereby mutually agreed to, by and between the Owner and Contractor:

Article 1

DEFINITIONS

- 1.1 All terms in this Agreement which are defined in the Information for Bidders and the General Conditions shall have the meanings designated therein.

- 1.2 The Contract Documents are as defined in the General Conditions. Such documents form the Contract, and all are as fully a part thereof as if attached to this Agreement or repeated herein.

Article 2

STATEMENT OF THE WORK

- 2.1 The Project is the Work identified in the plans and specifications prepared by REI Engineers, Inc. dated TBD, 2024 for Orange County Board of Education, including the following addenda:

A listing of the plans and specifications included in the Contract Documents is attached as Exhibit A.

- 2.2 The Parties agree that the Project shall include the following alternates:

None

- 2.3 The Parties agree to the following modifications to the Project's plans and specifications, including the noted value engineering items:

List item(s) and proposed deduct/add(s). If none, delete this language list "None"

- 2.4 The Contractor shall provide and pay for all materials, tools, equipment, labor and professional and non-professional services, and shall perform all other acts and supply all other things necessary, to fully and properly perform and complete the Work, as required by the Contract Documents.

- 2.5 The Contractor shall further provide and pay for all related facilities described in any of the Contract Documents, including all work expressly specified therein and such additional work as may be reasonably inferred therefrom, saving and excepting only such items of work as are

specifically stated in the Contract Documents not to be the obligation of the Contractor. The totality of the obligations imposed upon the contractor by this Article and by all other provisions of the Contract Documents, as well as the structures to be built and the labor to be performed, is herein referred to as the "Work".

Article 3

DESIGN CONSULTANT

- 3.1 The Design Consultant (as defined in the General Conditions) shall be **REI Engineers, Inc.** whose address is **9121 Anson Way, Suite 100, Raleigh, NC 27615**, however, that the Owner may, without liability to the Contractor, unilaterally amend this Article from time to time by designating a different person or organization to act as its Design Consultant and so advising the Contractor in writing, at which time the person or organization so designated shall be the Design Consultant for purposes of this Contract.

Article 4

TIME OF COMMENCEMENT AND COMPLETION

- 4.1 The Contractor shall commence the Work promptly upon the date established in the Notice to Proceed. If there is no Notice to Proceed, the date of commencement of the Work shall be the date of this Agreement or such other date as may be established herein.
- 4.2 Time is of the essence. The Contractor shall achieve Final Completion, as defined in the General Conditions on or before the date established for Final Completion in the Supplementary Conditions.
- 4.3 The Supplementary Conditions contains certain specific dates that shall be adhered to and are the last acceptable dates unless modified in writing by mutual agreement between the Contractor and the Owner. All dates indicate midnight unless otherwise stipulated. The only exceptions to this schedule are defined in the General Conditions under 8.3 DELAYS AND EXTENSIONS OF TIME.

4.4 Should the Contractor fail to complete the Work on or before the dates stipulated for Substantial Completion and/or Final Completion, or such later date as may result from an extension of time granted by the Owner, he shall pay the Owner, as liquidated damages the sums set forth in the General and Supplementary Conditions.

Article 5

CONTRACT SUM

5.1 Provided that the Contractor shall strictly and completely perform all of its obligations under the Contract Documents, and subject only to additions and deductions by Modification or as otherwise provided in the Contract Documents, the Owner shall pay to the Contractor, in current funds and at the time and in the installments hereinafter specified, the sum of _____ Dollars (\$ _____) herein referred to as the "Contract Sum". This amount includes the base bid and the Alternates in Section 2.2

5.2 The Contract Sum includes the value engineering items and other contract modifications noted in Section 2.3 above that total \$_____.

5.3 Unit Prices are established as follows for the Project:

Unit Price No. 1	Repoint 12,000 LF Deteriorated Mortar Joints.	\$_____/LF
Unit Price No. 2	Replace 250 Broken/ Deteriorated CMU Veneer Units	\$_____/EA
Unit Price No. 3	Replace 250 SF Concrete Sidewalk	\$_____/SF

Article 6

PROGRESS PAYMENTS

- 6.1 The Contractor hereby agrees that on or about the First day of the month for every month during the performance of the Work he will deliver to the Owner's Project Manager an Application for Payment in accordance with the provisions of Article 9 of the General Conditions. This date may be changed upon mutual agreement, stated in writing, between the Owner and Contractor. Payment under this Contract shall be made as provided in the General Conditions. Payments due and unpaid under the Contract Documents shall not bear interest.

Article 7

OTHER REQUIREMENTS

- 7.1 The Contractor shall submit the Performance Bond, Labor and Material Payment Bond and Certification of Insurance as required by the Contract Documents.
- 7.2 The Owner shall furnish to the Contractor one **(1)** set of drawings and one **(1)** set of specifications, at no extra cost, for use in the Construction of the Work. Additional sets of drawings or specifications may be obtained by the Contractor by paying the Owner for the costs of reproduction, handling and mailing.
- 7.3 The Contractor shall make a good faith effort to utilize Historically Underutilized Businesses (HUB's) per N.C. Gen. Stat. 143-128.2, and as described in the construction documents.
- 7.4 The General Conditions, Supplemental Conditions and the plans and specifications, including any addenda, are incorporated herein by reference.

IN WITNESS WHEREOF, _____ Board of Education (hereinbefore called the "Owner") has caused these presents to be signed and its corporate seal to be hereunto affixed, attested by its Chairperson and Secretary, and _____ (hereinbefore called "Contractor") has caused these presents to be signed by its President and its Corporate seal to be hereunto affixed, as hereinafter attested, all as of the day and year first above written.

_____ **BOARD OF EDUCATION**

Board Chairperson

ATTEST:

Superintendent

[Corporate Seal]

By: _____

, President or Vice-President

(Print Name)

ATTEST:

Corporate Secretary

[Corporate Seal]

This instrument has been preaudited in the manner required by the School Budget and Fiscal Control Act.

Finance Officer

Date

SECTION 00 60 00

PROJECT FORMS

PART 1 GENERAL

1.1 SUMMARY

- A. The following documents are hereby incorporated into the Contract Documents by reference:
1. AIA Documents: Properly licensed forms are available for purchase from the American Institute of Architects at www.aia.org/documents. Utilize current version of each document.
 - a. G702 Application and Certificate for Payment
 - b. G703 Continuation Sheet
 - c. G706 Contractor's Affidavit of Payment of Debts and Claims
 - d. G706A Contractor's Affidavit of Payment of Release of Liens
 - e. G707 Consent of Surety to Final Payment
- B. The following documents are included in the Project Manual:
1. Section 00 61 13.13 - Performance Bond Form
 2. Section 00 61 13.16 - Payment Bond Form
 3. Section 00 62 76.13 - Sales Tax Report
 4. Section 00 63 13 - Request for Interpretation
 5. Section 00 63 25 - Substitution Request Form
 6. Section 00 63 55 - Change Proposal Form
 7. Section 00 65 36 - Contractor's Warranty
 8. Section 00 65 37 - Asbestos Free Warranty

END OF SECTION

SECTION 00 61 13.13

PERFORMANCE BOND FORM

PART 1 GENERAL

1.1 SUMMARY

- A. Section Includes:
 - 1. Utilize Owner's required Performance Bond Form attached to this section.

1.2 RELATED DOCUMENTS

- A. Drawings and general provisions of the Contract, including General and Supplementary Conditions and Specification Sections apply to this Section.

1.3 GENERAL

- A. A Performance Bond in the amount of the contract is required.
- B. Include the cost of providing bonds in the Base Bid.
- C. Deliver the required bonds to the Owner no later than three days following the date of execution of the Contract. If the Work is to be commenced prior thereto in response to a letter of intent, prior to commencement of the Work, submit evidence satisfactory to the Owner that such bonds will be furnished and delivered in accordance with this Section.
- D. Write bonds on the forms contained or referenced herein.
- E. Write bond in the amount of the Contract Sum.
- F. Date bonds on the date of the Contract.
- G. Issue bonds by sureties and execute by an attorney-in-fact, on behalf of the surety, who is authorized to do business in the State of North Carolina .
- H. Affix thereto a certified and current copy of the power of attorney.

END OF SECTION

PERFORMANCE BOND

IT IS HEREBY AGREED that

(Insert full name and address of Contractor)

as Principal, hereinafter called Contractor, and,

(Insert full name and address of Surety)

as Surety, hereinafter called Surety, are held and firmly bound unto the

as Obligee, hereinafter called Owner, in the amount of _____ Dollars (\$ _____), for the payment whereof Contractor and Surety bind themselves, their heirs, executors, administrators, successors and assigns, jointly and severally, firmly by these obligations.

WHEREAS, Contractor has by written agreement dated _____, 20____, entered into a contract with Owner for the construction of _____ (Insert the name of the Project)

in accordance with Drawings and Specifications prepared by _____ (Insert full name and address of Architect/Engineer)

which contract is by reference made a part hereof, and is hereinafter referred to as the Contract.

NOW, THEREFORE, THE CONDITION OF THIS OBLIGATION is such that, if Contractor shall promptly and faithfully perform said Contract, then this obligation shall be null and void; otherwise it shall remain in full force and effect. The Surety hereby waives notice of any alteration or extension of time made by the Owner.

Whenever Contractor shall be, and declared by Owner to be in default, under the Contract, the Owner having performed Owner's obligations thereunder, the Surety may promptly remedy the default, or shall promptly:

- 1) Complete the Contract in accordance with its terms and conditions, or
- 2) Obtain a bid or bids for completing the Contract in accordance with its terms and conditions, and upon determination by Surety of the lowest responsible bidder, or, if the Owner elects, upon determination by the Owner and the Surety jointly of the lowest

responsible bidder, arrange for a contract between such bidder and Owner, and make available as Work progresses (even though there should be a default or a succession of defaults under the contract or contracts of completion arranged under this paragraph) sufficient funds to pay the cost of completion less the balance of the contract price; but not exceeding, including other costs and damages for which the Surety may be liable hereunder, the amount set forth in the first paragraph hereof. The term "balance of the contract price," as used in this paragraph, shall mean the total amount payable by Owner to Contractor under the Contract and any amendments thereto, less the amount properly paid by Owner to Contractor.

Any suit under this bond must be instituted before the expiration of any applicable statute of limitations under the Contract.

No right of action shall accrue on this bond to or for the use of any person or corporation other than the Owner named herein or the heirs, executors, administrators or successors of the Owner.

Signed and sealed this _____ day of _____ 20_____.

PRINCIPAL

[Affix corporate seal]

(Name) _____
(Title) _____

(Witness)

SURETY

[Affix corporate seal]

(Name) _____
(Title) _____

(Witness)

SECTION 00 61 13.16

PAYMENT BOND FORM

PART 1 GENERAL

1.1 SUMMARY

A. Section Includes:

1. Utilize Owner's required Payment Bond Form attached to this section.

1.2 RELATED DOCUMENTS

A. Drawings and general provisions of the Contract, including General and Supplementary Conditions and Specification Sections apply to this Section.

1.3 GENERAL

- A. A Labor and Material Payment Bond in the amount of the contract is required.
- B. Include the cost of providing bonds in the Base Bid.
- C. Deliver the required bonds to the Owner no later than three days following the date of execution of the Contract. If the Work is to be commenced prior thereto in response to a letter of intent, prior to commencement of the Work, submit evidence satisfactory to the Owner that such bonds will be furnished and delivered in accordance with this Section.
- D. Write bonds on the forms contained or referenced herein.
- E. Write bond in the amount of the Contract Sum.
- F. Date bonds on the date of the Contract.
- G. Issue bonds by sureties and execute by an attorney-in-fact, on behalf of the surety, who is authorized to do business in the State of North Carolina .
- H. Affix thereto a certified and current copy of the power of attorney.

LABOR AND MATERIAL PAYMENT BOND

THIS BOND IS ISSUED SIMULTANEOUSLY WITH PERFORMANCE BOND IN FAVOR OF THE OWNER CONDITIONED ON THE FULL AND FAITHFUL PERFORMANCE OF THE CONTRACT

IT IS HEREBY AGREED that _____ (Insert full name and address of Contractor)

as Principal, hereinafter called "Principal," and, _____ (Insert full name and address of Surety)

as Surety, hereinafter called "Surety," are held and firmly bound unto the

as Obligee, hereinafter called Owner, for the use and benefit of claimants as hereinbelow defined, in the amount of _____ Dollars (\$ _____), for the payment whereof Principal and Surety bind themselves, their heirs, executors, administrators, successors and assigns, jointly and severally, firmly by these obligations.

WHEREAS, Principal has by written agreement dated _____, 20_____, entered into a contract with Owner for the construction of _____ (Insert the name of the Project)

in accordance with Drawings and Specifications prepared by _____ (Insert full name and address of Architect/Engineer)

which contract is by reference made a part hereof, and is hereinafter referred to as the "Contract."

NOW, THEREFORE, THE CONDITION OF THIS OBLIGATION is such that, if Principal shall promptly make payment to all claimants as hereinafter defined, for all labor and material used or reasonably required for use in the performance of the Contract, then this obligation shall be void; otherwise it shall remain in full force and effect, subject, however, to the following conditions:

1. A claimant is defined as one having a direct contract with the principal or with a Subcontractor of the Principal for labor, material, or both, used or reasonably required for use in the performance of the Contract, labor and material being construed to include that part of water, gas, power, light, heat, oil, gasoline, telephone service or rental of equipment directly applicable to the Contract.
2. The above named Principal and Surety hereby jointly and severally agree with the Owner that every claimant as herein defined, who has not been paid in full before the expiration of a period of ninety (90) days after the date on which the last of such claimant's work or labor was done or performed, or materials were furnished by such claimant, may sue on this bond for the use of such claimant, prosecute the suit to final judgment for such sum or sums as may be justly due claimant, and have execution thereon. The Owner shall not be liable for the payment of any costs or expenses of any such suit.
3. No suit or action shall be commenced hereunder by any claimant:
 - a) Unless claimant, other than one having a direct contract with the Principal, shall have given written notice to any two of the following: the Principal, the Owner, or the Surety above named, within ninety (90) days, after such claimant did or performed the last of the work or labor, or furnished the last of the materials for which said claim is

made, stating with substantial accuracy the amount claimed and the name of the party to whom the materials were furnished, or for whom the work or labor was done or performed. Such notice shall be served by mailing the same by registered mail or certified mail; postage prepaid, in an envelope addressed to the Principal, Owner or Surety, at any place where an office is regularly maintained for the transaction of business, or served in any manner in which legal process may be served in the state in which the aforesaid project is located, save that such service need not be made by a public officer.

b) After the expiration of one (1) year following the date on which Principal ceased Work on said Contract, it being understood, however, that if any limitation embodied in this bond is prohibited by any law controlling the construction hereof such limitation shall be deemed to be amended so as to be equal to the minimum period of limitation permitted by such law.

c) Other than in a state court of competent jurisdiction in and for the county or other political subdivision of the state in which the Project, or any part thereof, is situated, or in the United States District Court for the district in which the Project, or any part thereof, is situated, and not elsewhere.

4. The amount of this bond shall be reduced by and to the extent of any payment or payments made in good faith hereunder, inclusive of the payment by Surety of mechanics' liens which may be filed of record against said improvement, whether or not claim for the amount of such lien be presented under and against this bond.

Signed and sealed this ____ day of _____ 20 ____.

PRINCIPAL

[Affix corporate seal]

(Name) _____
(Title) _____

(Witness)

SURETY

[Affix corporate seal]

(Name) _____
(Title) _____

(Witness)

SECTION 00 62 76.13

SALES TAX REPORT

PART 1 GENERAL

1.1 SUMMARY

A. Section Includes:

1. Submit the attached State and County Sales/Use Tax Statement and Certification with each application for payment.

1.2 RELATED DOCUMENTS

A. Drawings and general provisions of the Contract, including General and Supplementary Conditions and Specification Sections apply to this Section.

**SECTION 00 63 13
REQUEST FOR INTERPRETATION**

Project:	New Hope Elementary School Building Enclosure Maintenance & Repair	RFI Number:	
From:		Date:	
Engineer:	REI Engineers, Inc.	REI Project No.:	023RAL-049

Specification Section:

Paragraph:

Drawing Reference:

Request:

Signed By: _____

Response:

Attachments:

Response From: _____ Date Rec'd: _____ Date Ret'd: _____

Signed By: _____ Date: _____

Copies: __ Owner __ Contractor __ Engineer __ Other

END OF SECTION

**SECTION 00 63 25
SUBSTITUTION REQUEST FORM**

PART 1 -

Project Name: New Hope Elementary School Building Enclosure Maintenance & Repair

Date: _____

Product and/or Fabrication Method: _____

Specification Section: _____

Related Drawings: _____

Criteria or Specified Product	Included
Product Data	_____
Fabrication Drawings	_____
Samples Where Applicable	_____
List of changes or Modifications Needed to Work as Specified	_____

Criteria or Specified Product	Included
Product Data	_____
Fabrication Drawings	_____
Samples Where Applicable	_____
List of changes or Modifications Needed to Work as Specified	_____

The substitution proposed is equal-to or better in every respect to that required by the Contract Documents, and it will perform equal or superior to product specified in the application indicated. The Contractor waives right to additional payment or time, that may subsequently become necessary because of the failure of the substitution to perform adequately.

Signed: _____

END OF SECTION

SECTION 00 63 55

CHANGE PROPOSAL FORM

PART 1 GENERAL

1.1 CHANGE PROPOSAL FOR:

- A. New Hope Elementary School Building Enclosure Maintenance & Repair
- B. From (Contractor): _____
- C. Change Proposal No. _____
- D. Description of Change: _____

1.2 CHANGE BREAKDOWN

- A. Materials:
 - 1. Total direct cost of materials: \$ _____
 - 2. Overhead & profit on A1 (15% max.): \$ _____
 - 3. Sales tax: \$ _____
 - 4. Shipping & transportation: \$ _____
 - 5. Total Materials (A1+A2+A3+A4): \$ _____
- B. Labor:
 - 1. Total manhours: _____ mh at \$ _____ /hr. = \$ _____
 - 2. Overhead & profit on B1 (15% max.): \$ _____
 - 3. Payroll taxes and insurance: _____ %: \$ _____
 - 4. Total Labor (B1+B2+B3): \$ _____
- C. Equipment Rental:
 - 1. Equipment Rental
 - 2. Overhead & profit on C1 (6% max.): \$ _____
 - 3. Total Equipment Rental (C1+C2): \$ _____
- D. Subcontractors:
 - 1. Subcontractors: \$ _____
 - 2. Overhead & profit on D1 (6% max.): \$ _____

3. Total Subcontractors (D1+D2): \$ _____
- E. Subtotal of Proposal (A5+B4+C3+D3): \$ _____
- F. Bonds (% of Subtotal (E)): \$ _____
- G. Total of Change Proposal (E+F): \$ _____
- H. Time Extension Request: _____ calendar days
- I. The Contractor agrees to perform the work outlined in this change proposal for the amount specified above in accordance with the Contract Documents if the work is authorized by the Owner.
1. Contractor Signature and Date: _____
2. Engineer Recommended Approval and Date: _____
3. Owner Approval and Date: _____

END OF SECTION

**SECTION 00 65 16
CERTIFICATE OF SUBSTANTIAL COMPLETION**

Project:

Contractor:

Owner:

Engineer:

REI Project No.:

The Work performed under this Contract has been reviewed and found, to the Engineer's best knowledge, information and belief, to be substantially complete. Substantial Completion is the stage in the progress of the Work when the Work or designated portion is sufficiently complete in accordance with the Contract Documents so that the Owner can occupy or utilize the Work for its intended use. The date of Substantial Completion of the Project is the date of issuance established by this Certificate, which is also the date of commencement of applicable warranties required by the Contract Documents, except as stated below (list below or indicated "None"):

REI Engineers, Inc.

Engineer

By

Date of Issuance

A list of items to be completed or corrected (Punch List) is attached hereto. The failure to include any items on such list does not alter the responsibility of the Contractor to complete all Work in accordance with the Contract Documents.

Cost estimate of Work that is incomplete or defective: \$ _____ (to date as signed above).

The Contractor will complete or correct the Work on items described as defective hereto within fifteen (15) days from the Date of Issuance

Contractor

By

Date

The Owner accepts the Work as substantially complete and will assume full possession at 12:00 AM on the day immediately following the Date of Issuance.

Owner

By

Date

SECTION 00 65 36

CONTRACTOR'S WARRANTY

PART 1 GENERAL

1.1 WARRANTY

- A. Know all men by these presents, that we, _____ (Contractor), having installed exterior wall repairs and exterior storm water system on the New Hope Elementary School Building Enclosure Maintenance & Repair under contract between Orange County Schools and Contractor, warrant to the Owner with respect to said work that for the period specified below, the work shall be watertight and free from defects, provided however the following are excluded from this Warranty: 1) defects or failures resulting from abuse by the Owner, 2) damages caused by fire, tornado, hail, hurricane, acts of God, wars, vandalism, riots or civil commotion, and 3) defects in design involving failure of structural frame, load bearing walls, and/or foundations. We agree that should any leaks occur in the work we will perform emergency repairs within 24 hours' notice and perform permanent repairs promptly in a manner to restore the work to a watertight condition by methods compatible to the system, acceptable under industry standards and general practice, and acceptable to the Manufacturer, all at no expense to the Owner. We further agree that for the period specified below, we will make repairs at no expense to the Owner to defects which may develop in the work in a manner compatible to the system, acceptable under industry standards and general practice as established by the Engineer and acceptable to the Manufacturer. We agree to attend one post construction field inspection no earlier than one month prior to the Contractor's Warranty expiration date and to complete corrective actions requested by Owner, Engineer, or Manufacturer at no additional cost to the Owner.
- B. Warranty Period: 2 years from date of substantial completion of _____, 20__.

1.2 EXECUTED BY

- A. Contractor: _____
- B. Authorized Signing Officer Name: _____
- C. Authorized Signing Office Title: _____
- D. Signature: _____ Date: _____

1.3 NOTARIZED BY:

- A. I, _____ (print name), a Notary Public for _____ County of _____ (State), do hereby certify that _____ (officer listed above) personally appeared before me this day and acknowledged the due execution of the foregoing instrument. Witness my hand and official seal, this ____ day of _____, 20 ____ . My commission expires ____ of _____, 20 ____ .
- B. Signed: _____

(OFFICIAL SEAL)

END OF SECTION

SECTION 00 65 37

ASBESTOS FREE WARRANTY

PART 1 GENERAL

1.1 FOR

- A. Owner: Orange County Schools
- B. Project: New Hope Elementary School Building Enclosure Maintenance & Repair
- C. Project Address: 1900 New Hope Church Road, Chapel Hill, North Carolina 27514

1.2 WARRANTY

- A. Date of Substantial Completion: _____
- B. Know all men by these presents, that we, _____
(Contractor) having furnished labor, materials, equipment and/or supplies, removed existing roof system; installed new roof system and/or miscellaneous components; from, to and/or on the above referenced project under contract between the Owner and Contractor, warrant to Owner with respect to said work that no materials containing asbestos fibers were incorporated into the work, and that, to our knowledge and belief, no materials containing asbestos remain in or are covered by the work.
- C. Exceptions: _____ If there are no exceptions, state "None".

1.3 EXECUTED BY

- A. Contractor: _____
- B. Authorized Signing Officer Name: _____
- C. Authorized Signing Office Title: _____
- D. Signature: _____ Date: _____

1.4 NOTARIZED BY:

- A. I, _____ (print name), a Notary Public for _____ County of _____ (State), do hereby certify that _____ (officer listed above) personally appeared before me this day and acknowledged the due execution of the foregoing instrument. Witness my hand and official seal, this _____ day of _____, 20 _____. My commission expires ____ of _____, 20 ____.
- B. Signed: _____

(OFFICIAL SEAL)

END OF SECTION

SECTION 00 72 13

GENERAL CONDITIONS OF THE CONTRACT

PART 1 GENERAL

1.1 SUMMARY

A. Section Includes:

1. Owner's General Conditions of the Contract.

1.2 RELATED DOCUMENTS

A. Drawings and general provisions of the Contract, including General and Supplementary Conditions and Specification Sections apply to this Section.

SECTION V

GENERAL CONDITIONS

NOTICE OF DISCLAIMER

TAKE NOTICE, that these General Conditions may contain language and Article, Section or Paragraph headings or names which appear similar to or the same as the provisions of the "General Conditions of the Contract for Construction", published by the American Institute of Architects, AIA Document A-201.

TAKE NOTICE, however, that these General Conditions are substantially and materially different in many respects from the AIA Document A-201 and that certain additions, deletions or other modifications have been made to provisions similar to those contained in the AIA Document. This document, further, contains provisions, which do not appear in the AIA document.

The use of any language or Article or Paragraph format similar to or the same as AIA Document A-201 does not constitute an endorsement by the American Institute of Architects of this document.

SECTION V GENERAL CONDITIONS OF THE CONTRACT FOR CONSTRUCTION

TABLE OF ARTICLES

- | | |
|---|--|
| 1. CONTRACT DOCUMENTS | 9. PAYMENTS AND COMPLETION |
| 2. DESIGN CONSULTANT | 10. PROTECTION OF PERSONS AND PROPERTY |
| 3. OWNER | |
| 4. CONTRACTOR | 11. INSURANCE |
| 5. SUBCONTRACTORS | 12. CHANGES IN THE WORK |
| 6. WORK BY OWNER OR BY SEPARATE CONTRACTORS | 13. UNCOVERING AND CORRECTION |
| 7. MISCELLANEOUS PROVISIONS | 14. TERMINATION OF THE CONTRACT |
| 8. TIME | 15. DISPUTE RESOLUTION |

ARTICLE 1

CONTRACT DOCUMENTS

- 1.1 DEFINITIONS
 - 1.1.1 AS SHOWN, AS INDICATED, AS DETAILED: These words, and words of like implication, refer to information contained in Drawings and Specifications describing the Work, unless explicitly stated otherwise in the Contract Documents.
 - 1.1.2 CLAIM: A Claim as used in the Contract is a demand or assertion by one of the parties seeking, as a matter of right, adjustment or interpretation of contract terms, payment of money, a credit against the payment of money, extension of time or other relief with respect to the terms of the

Contract. The term Claim also includes other disputes and matters in question between the parties to a contract involved in the Owner's construction and repair projects arising out of or relating to the Contract or the construction process.

- 1.1.3 **CONTRACT:** The Contract is the sum of all the Contract Documents. The Contract represents the entire and integrated agreement between the Owner and the Contractor and supersedes all prior negotiations, representations, or agreements, either written or oral. The Contract may be amended or modified only by a Modification as defined in Paragraph 1.1.4. The Contract may also be referred to in the Contract Documents as "this Contract", "this Agreement" or "the Agreement".
- 1.1.4 **CONTRACT DOCUMENTS:** The Contract Documents consist of the Owner-Contractor Agreement, the Conditions of the Contract (General and Supplemental Conditions), the Plans, Drawings, and Specifications, and all Addenda thereto issued prior to and all Modifications thereto issued after execution of the Contract. A Modification is (1) a written amendment to the Contract signed by both parties; (2) a Change Order or a Construction Change Directive issued pursuant to the provisions of Article 12; (3) a written interpretation issued by the Design Consultant pursuant to Paragraph 2.2.7; or (4) a written order for a minor Change in the Work issued pursuant to Section 12.4. The Contract Documents do not include any other documents including but not limited to soils, geotechnical or other reports, surveys and analysis, which may be printed, bound or assembled with the Contract Documents, or otherwise made available to the Contractor for review or information under this Contract, unless specifically enumerated and directly incorporated by reference in the Contract Documents.
- 1.1.5 **HE/HIS:** The term He or His is not intended to be gender specific.
- 1.1.6 **MANUFACTURER:** An individual, company, or corporation who manufactures, fabricates, or assembles a standard product. A standard product is one that is not made to special design, and if furnished by either direct sale or by contract to the Contractor, Subcontractor or Vendor.
- 1.1.7 **MATERIAL SUPPLIER OR VENDOR:** A person or organization who supplies, but who is not responsible for the installation of, materials, products and equipment.
- 1.1.8 **NOTICE:** The term Notice as used herein shall mean and include written notice. Notice shall be deemed to have been given when delivered to the address of the person, firm or corporation for whom intended, or to his, their or its duly authorized agent, representative or officer; or when enclosed in a postage prepaid wrapper or envelope addressed to such person, firm or corporation at his, their or its Notice Address and deposited in a United States mailbox by registered or certified mail. To "Notify" means to give Notice. The Notice Addresses for the Owner and Contractor are stated in the Owner-Contractor Agreement and may be changed by a party by giving Notice to the other of such change.
- 1.1.9 **PLANS OR DRAWINGS:** All drawings or reproduction of drawings pertaining to the Work.
- 1.1.10 **PRODUCT:** The term Product includes materials, systems and equipment.
- 1.1.11 **PROJECT:** The Project is the total construction of which the Work performed under the Contract Documents may be the whole or a part.
- 1.1.12 **PROPOSAL:** A complete and properly signed document whereby the Contractor proposes to provide additional or a reduced scope of construction work on the Project for the sums stipulated therein, supported by data required by the Design Consultant or Owner.

- 1.1.13 PROVIDE: As a directive to the Contractor, and as pertaining to labor, materials or equipment, "provide" means "furnish and install completely".
- 1.1.14 SPECIFICATIONS: Descriptions, provisions and requirements, pertaining to method and manner of performing the Work, or to quantities and qualities of materials or equipment to be furnished under terms of the Contract.
- 1.1.15 WORK: The Work comprises the construction and services required of the Contractor by the Contract Documents and includes all labor, supplies and other facilities or things necessary to produce such construction, and all materials, equipment, and supplies incorporated or to be incorporated in such construction.
- 1.2 EXECUTION, CORRELATION AND INTENT
- 1.2.1 The Contractor and Owner acknowledge that neither these General Conditions, nor any other Contract Document shall be construed against the Owner due to the fact that they may have been drafted by the Owner or the Owner's agent. For the purposes of construing these General Conditions, and any other Contract Document, both the Contractor and the Owner shall be considered to have jointly drafted them.
- 1.2.2 The Owner-Contractor Agreement shall be signed in not less than three (3) copies by the Owner and Contractor, and each of which shall be deemed an original, but all of which shall constitute one and the same instrument.
- 1.2.3 By executing the Contract, the Contractor represents that he has visited the site, familiarized himself with the local conditions under which the Work is to be performed, and correlated his observations with the requirements of the Contract Documents.
- 1.2.4 The intent of the Contract Documents is to include all items necessary for the proper execution and completion of the Work. The Contract Documents are complementary, and what is required by any one shall be as binding as if required by all. Performance by the Contractor shall be required only to the extent consistent with the Contract Documents and reasonably inferable from them as being necessary to produce the intended results. Words and abbreviations which have well-known technical or trade meanings are used in the Contract Documents in accordance with such recognized meanings unless otherwise specifically defined herein. The table of contents, titles, headings, running headlines and marginal notes contained herein and in said documents are solely to facilitate reference to various provisions of the Contract Documents and in no way affect, limit or cast light upon the interpretation of the provisions to which they refer.
- 1.2.5 The organization of the Specifications into divisions, sections and articles, and the arrangement of Drawings are for convenience only. The Contractor may subcontract the Work in such divisions as he sees fit consistent with applicable law and he is ultimately responsible for furnishing all of the Work.
- 1.2.6 Anything shown on the Drawings and not mentioned in the Specifications or mentioned in the Specifications and not shown on the Drawings shall have the same effect as if shown or mentioned respectively in both. Detailed specifications take priority over general specifications and detailed drawings take precedence over general drawings. Any Work shown on one drawing shall be construed to be shown in all drawings. If any portion of the Contract Documents shall be in conflict with any other portion, the various documents comprising the

Contract Documents shall govern in the following order of precedence: The Owner-Contractor Agreement; the Supplemental Conditions; the General Conditions; the Specifications; the Drawings. The Contractor shall notify the Design Consultant and the Owner of all such inconsistencies promptly. Any such conflict or inconsistency between or in the Drawings or Specifications shall be submitted by the Contractor promptly to the Owner and Design Consultant and the Design Consultant's decision thereon shall be final and conclusive.

- 1.2.7 The Contractor agrees that nothing contained in the Contract Documents or any contract between the Owner and the Design Consultant shall create any contractual relationship between the Design Consultant and the Contractor, or between the Design Consultant and any Subcontractor or Sub-subcontractors. The Contractor acknowledges and agrees that this Contract is not intended to create, nor shall any provision be interpreted as creating, any contractual relationship between the Owner or Contractor and any third parties.
- 1.2.8 The provisions of this Contract cannot be amended, modified, varied or waived in any respect except by a Modification. The Contractor is hereby given notice that no person has authority to orally waive, or to release the Contractor from any of the Contractor's duties or obligations under or arising out of this Contract. Any waiver, approval or consent granted by Modification to the Contractor shall be limited to those matters specifically and expressly stated thereby to be waived, approved or consented to and shall not relieve the Contractor of the obligation to obtain any future waiver, approval or consent.
- 1.2.9 Any material or operation specified by reference to published specifications of a Manufacturer, a society, an association, a code, or other published standard, shall comply with requirements of the listed document which is current on date the Owner received bids for the construction of the Project. In case of a conflict between referenced document and the Specifications, Specifications shall govern. In case of a conflict between such listed documents, the one having more stringent requirements shall govern.
- 1.2.10 The Contractor, if requested, shall furnish an affidavit from each or any Manufacturer certifying that materials or products delivered to the job meets requirements specified.

1.3 OWNERSHIP AND USE OF DOCUMENTS

- 1.3.1 All Drawings, Specifications and copies thereof furnished by the Design Consultant are and shall remain the property of the Owner. They are to be used by Contractor only with respect to the Project and are not to be used by Contractor on any other project. With the exception of one contract set for each party to the Contract, such documents are to be returned or suitably accounted for to the Owner on request at the completion of the Work. Submission or distribution to meet official regulatory requirements or for other purposes in connection with the Project is not to be construed as publication in derogation of Owner's rights or the Design Consultant's common law copyright or other reserved rights.

ARTICLE 2

THE DESIGN CONSULTANT

2.1 DEFINITIONS

2.1.1 The term "Design Consultant" or "A/E" or "Architect" or "Engineer" as used or set forth in the Contract Documents, shall mean the entity and its consultants or agents, or their duly authorized representatives, that is responsible for designing or engineering the Work, and performing the activities specified herein, and in the Agreement for Design Consultant Services, including any consultants to said entity or firm acting within the scope of their agreements with the Design Consultant. Such firm or agency and its representatives shall act severally within the scope of particular duties entrusted to them, unless otherwise provided for in the Contract Documents or in the Agreement for Design Consultant Services.

2.1.2 The Design Consultant may be identified in the Owner-Contractor Agreement and is referred to throughout the Contract Documents as if singular in number and masculine in gender. The Design Consultant is further described as and, throughout this document, shall mean one or both of the following:

2.1.2.1 ARCHITECT, a person or other legal entity lawfully licensed to practice architecture in the State wherein the Project is located; or

2.1.2.2 ENGINEER, a person or other legal entity lawfully licensed to practice engineering in the State wherein the Project is located.

2.2 SERVICES OF THE DESIGN CONSULTANT

2.2.1 The Design Consultant will provide certain services as hereinafter described and further described in the Agreement for Design Consultant Services.

2.2.2 Should errors, omissions, or conflicts in the Drawings, Specifications, or other Contract Documents prepared by or on behalf of the Design Consultant be discovered, the Design Consultant will prepare such amendments or supplementary documents and provide consultation as may be required.

2.2.3 The Design Consultant will visit the site at intervals appropriate to the stage of construction to familiarize itself generally with the progress and quality of the Work and to determine in general if the Work is proceeding in accordance with the Contract Documents. The Design Consultant will not be required to make exhaustive or continuous on-site inspections to check the quality or quantity of the Work, but it shall make as many inspections as may reasonably be required to fulfill its obligations to the Owner. On the basis of such on-site observations, the Design Consultant and his consultants shall endeavour to guard the Owner against defects and deficiencies in the Work. The Design Consultant will conduct the weekly construction meeting and shall be responsible for preparing accurate and complete minutes of all such meetings and other Project meetings and distributing same to all participants.

2.2.4 The Design Consultant will render written field reports to the Owner in the form required by the Owner relating to the periodic visits and inspections of the Project required by Paragraph 2.2.3.

- 2.2.5 The Design Consultant will not be responsible for and will not have control or charge of construction means, methods, techniques, sequences or procedures, or for safety precautions and programs in connection with the Work, and he will not be responsible for the Contractor's failure to carry out the Work in accordance with the Contract Documents. The Design Consultant will not be responsible for or have control or charge over the acts or omissions of the Contractor, Subcontractors, or any of their agents or employees, or any other persons performing any portion of the Work.
- 2.2.6 The Design Consultant shall at all times have access to the Work wherever it is in preparation or progress. The Contractor shall provide safe facilities for such access so the Design Consultant may perform his functions under the Contract Documents.
- 2.2.7 As required, the Design Consultant will render to the Owner, within a reasonable time, interpretations concerning the design and other technical aspects of the Work and the Contract Documents.
- 2.2.8 All communications, correspondence, submittals, and documents exchanged between the Design Consultant and the Contractor in connection with the Project shall be through the Owner or in the manner prescribed by the Owner. Further, all communications, correspondence, submittals and documents transmitted from the Owner or Design Consultant will be directed to the Contractor and copied to the Owner or Design Consultant.
- 2.2.9 All interpretations and decisions of the Design Consultant shall be consistent with the intent of and reasonably inferable from the Contract Documents.
- 2.2.10 The Design Consultant's decisions in matters relating to artistic effect will be final if consistent with the intent of the Contract Documents.
- 2.2.11 If the Design Consultant observes any Work that does not conform to the Contract Documents, the Design Consultant shall report this observation to the Owner. The Design Consultant will prepare and submit to the Owner "punch lists" of the Contractor's work, which is not in conformance with the Contract Documents. The Owner will transmit such "punch lists" to the Contractor.
- 2.2.12 The Design Consultant has the authority to condemn or reject any or all of the Work on behalf of the Owner when, in its opinion, the Work does not conform to the Contract Documents. Whenever, in the Design Consultant's reasonable opinion, it is considered necessary or advisable for the implementation of the intent of the Contract Documents, the Design Consultant will have the authority to require special inspection or testing of any portion of the Work in accordance with the provisions of the Contract Documents whether or not such portion of the Work be then fabricated, installed or completed.
- 2.2.13 The Design Consultant will review the Contractor's submittals such as Shop Drawings, Product Data and Samples, but only for conformance with the design concept of the Work and for general compliance with the Contract Documents. Such action shall be taken within fourteen (14) days of receipt unless otherwise authorized by the Owner.
- 2.2.14 The Owner will establish with the Design Consultant procedures to be followed for review and processing of all Shop Drawings, catalogue submittals, project reports, test reports, maintenance manuals, and other necessary documentation, as well as requests for changes and applications for extensions of time.

- 2.2.15 The Design Consultant will prepare Change Orders and Construction Change Directives when requested by the Owner.
- 2.2.16 The Design Consultant and the Owner will conduct inspections to determine the dates of Substantial Completion and Final Completion. The Design Consultant will issue a final Certification of Payment.
- 2.2.17 The Design Consultant will prepare three (3) printed copies and one (1) electronic computer file compatible with the latest version of AutoCAD, or other program designated by Owner, showing significant Changes in the Work made during the construction process, based on neatly and clearly marked-up Drawings, prints, and other data furnished by the Contractor(s) and the applicable Addenda, clarifications and Change Orders which occurred during the Project. The Design Consultant will also provide the Owner assistance in the original operation of any equipment or system such as initial start-up, testing, adjusting, and balancing.
- 2.2.18 In case of the termination of the employment of the Design Consultant, the Owner may appoint a Design Consultant whose status under the Contract Documents shall be that of the former Design Consultant.

ARTICLE 3

OWNER

3.1 DEFINITION

- 3.1.1 The Owner is the person or entity identified as such in the Owner-Contractor Agreement and may be referred to throughout the Contract Documents as if singular in number and masculine in gender. The term Owner means the Owner or his authorized representative or agent. The phrase "Owner or its agent" as used in this Agreement, does not include the Separate Contractors or their Subcontractors.

3.2 INFORMATION, SERVICES AND RIGHTS OF THE OWNER

- 3.2.1 The Owner will provide administration of the Contract as herein described. The Design Consultant shall also provide aspects of administration of the Contract as herein described or as specified in the Agreement for Design Consultant Services.
- 3.2.2 The Owner shall at all times have access to the Work whenever it is in preparation or progress. The Contractor shall provide safe facilities for such access.
- 3.2.3 The Owner shall not be responsible for or have control or charge of the construction means, methods, techniques, sequences, or procedures, or for safety precautions and programs in connection with the Work, and will not be responsible for the Contractor's failure to carry out the Work in accordance with the Contract Documents.
- 3.2.4 The Owner will have authority to require special inspection or testing of portions of the Work to the same extent as the Design Consultant in accordance with Paragraph 2.2.12 whether or not such portion of the Work be then fabricated, installed, or completed. However, neither the Owner's authority to act under Paragraph 3.2.4, nor any decision made by the Owner in good faith either to exercise or not to exercise such authority shall give rise to any duty or responsibility of the Owner to the Contractor, any Subcontractor, any of their agents or

employees, or any other person performing any of the Work.

- 3.2.5 The Owner shall have the authority and discretion to call, schedule, and conduct job meetings to be attended by the Contractor, representatives of his Subcontractors, and the Design Consultant, to discuss such matters as procedures, progress, problems, and scheduling.
- 3.2.5.1 The Contractor is requested and required to attend weekly job site progress conferences as called by the Design Consultant. The Contractor shall be represented at these job progress conferences by project personnel authorized by the Contractor to make schedule and financial decision and by project personnel representatives. These meetings shall be open to Subcontractors, Material Suppliers, and any others who can contribute shall be encouraged by the Contractor to attend. It shall be the principal purpose of these meetings, or conferences, to affect coordination, cooperation and assistance in every practical way toward the end of maintaining progress of the Project on schedule and to complete the Project within the specified Contract Time. The Contractor shall be prepared to assist progress of the Work as required in his particular contract and to recommend remedial measures for the correction of progress as may be appropriate. The Design Consultant shall be the coordinator of the conferences and shall preside as chairman.
- 3.2.5.2 If the Project is awarded as a single prime construction contract, the Design Consultant shall determine which, if any, Subcontractors and/or Material Suppliers shall be required to attend weekly job site progress conferences. The Contractor shall comply with this request and the meeting shall be conducted as described in Subparagraph 3.2.5.1.
- 3.2.6 The Owner will establish procedures to be followed for processing all Shop Drawings, catalogues, and other project reports, and other documentation, test reports, and maintenance manuals.
- 3.2.7 The Owner and Design Consultant will review all requests for changes and shall implement the processing of Change Orders, including applications for extension of the Contract Time.
- 3.2.8 The Owner, will not be responsible for the failure of the Contractor to plan, schedule, and execute the Work in accordance with the approved schedule or the failure of the Contractor to meet scheduled Completion Dates or the failure of the Contractor to schedule and coordinate the Work of his own trades and Subcontractors or to coordinate and cooperate with any Separate Contractors.
- 3.2.9 The Owner, in consultation with the Design Consultant, will review and process all Applications for Payment by the Contractor, including the final Application for Payment.
- 3.2.10 The Owner and Design Consultant shall not be responsible or liable to Contractor for the acts, errors or omissions of the Contractor, Subcontractors, or their agents or employees, or any other persons performing any of the Work or working on the Project.
- 3.2.11 The Owner shall furnish surveys describing the physical characteristics and legal limitations for the site of the Project, which are in its possession and are relevant to the Work.
- 3.2.12 The Owner shall secure and pay for necessary easements, required for permanent structures or for permanent changes in existing facilities.
- 3.2.13 The Owner shall furnish information or services under the Owner's control with reasonable promptness to avoid unreasonable delay in the orderly progress of the Work.

- 3.2.14 Unless otherwise provided in the Contract Documents, the Contractor will be furnished, free of charge, copies of Drawings and Specifications in accordance with the Supplemental Conditions.
- 3.2.15 The Owner will make reasonable efforts to make available for the Contractor's reasonable review, at the Owner's offices or together with the Contract Documents, certain boring logs, geotechnical, soils and other reports, surveys and analyses pertaining to the Project site of which the Owner is aware, has in its possession and are relevant to the Work. Any boring logs that are provided to the Contractor are only intended to reflect conditions at the locations of the borings and do not necessarily reflect site conditions at other locations. Any reports, surveys and analyses provided by Owner are for the Contractor's information only, and their accuracy and completeness are not guaranteed or warranted by the Owner or the Design Consultant, and such reports are not adopted by reference into, nor are they part of the Contract Documents. Notwithstanding any factual statement, conclusion, or any language or recommendations contained in such reports, the Contractor assumes full responsibility for inspection of the site and determination of the character, quality and quantity of any soil, surface or subsurface conditions that may be encountered or which may affect the Work, and for the means and methods of construction that he employs when performing the Work.
- 3.2.16 The foregoing rights are in addition to other rights of the Owner enumerated herein and those provided by law.

3.3 OWNER'S RIGHT TO STOP OR TO SUSPEND THE WORK

- 3.3.1 If the Contractor fails to correct defective Work as required by Section 13.2 or fails to carry out the Work or supply labor and materials in accordance with the Contract Documents, the Owner by a written Notice may order the Contractor to stop the Work, or any portion thereof, until the cause for such order has been eliminated; however, this right of the Owner to stop the Work shall not give rise to any duty on the part of the Owner to exercise this right for the benefit of the Contractor or any other person or entity.
- 3.3.2 The Owner may order the Contractor in writing to suspend, delay, or interrupt all or any part of the Work for such period of time as he may determine to be appropriate for the convenience of the Owner.
- 3.3.3 If the performance of all or any part of the Work (including the work of the Contractor and its Subcontractors) is, for an unreasonable period of time, suspended, delayed, or interrupted by an act of the Owner or the Design Consultant, or by failure of any one of them to act within the time specified in this Contract (or if no time is specified, within a reasonable time), an adjustment shall be made for an increase in the actual time required for performance of the Work by the Contractor, due solely to such unreasonable suspension, delay, or interruption and the Contract modified in writing accordingly. However, no Claim shall be made under this Paragraph for any suspension, delay, or interruption pursuant to Paragraph 3.4.1, or for which Claim is provided or excluded under any other provision of this Contract. No Claim under this Paragraph shall be allowed on behalf of the Contractor or its Subcontractors, unless within twenty (20) days after the act or failure to act involved, and for continuing or ongoing acts or failures to act within twenty (20) days of the first day of the act or failure to act, the Contractor submits to the Owner a written statement setting forth, as fully as then practicable, the extent of such Claim, and unless the Claim is asserted in writing within thirty (30) days after the termination of such suspension, delay, or interruption. For continuing or ongoing acts or failures to act, the Contractor shall update its written statement every twenty (20) days until the suspension, delay or interruption is terminated. The Contractor shall waive any and all Claims under this Paragraph 3.3.3 which are not filed in strict conformance with Paragraph 3.3.3. The

Contractor shall indemnify, defend and hold the Owner harmless from any Claim by a Subcontractor that is waived because it is not filed in strict conformance with this Paragraph 3.3.3 or any other provision of the Contract regarding Claims.

3.3.4 In the event of a suspension of the Work or delay or interruption of the Work per Paragraph 3.3.3, the Contractor will and will cause his Subcontractors to protect carefully his, and their, materials and Work against damage, loss or injury from the weather and maintain completed and uncompleted portions of the Work as required by the Contract Documents. If, in the opinion of the Owner, any Work or material shall have been damaged or injured by reason of failure on the part of the Contractor or any of his Subcontractors to so protect same, such Work and materials shall be removed and replaced at the expense of the Contractor.

3.3.5 No Claim by the Contractor under Paragraph 3.3.3 shall be allowed if asserted after final payment under this Contract or if it is not asserted in strict conformance with Paragraph 3.3.3.

3.4 OWNER'S RIGHT TO CARRY OUT THE WORK

3.4.1 If the Contractor defaults or otherwise neglects to carry out the Work in accordance with the Contract Documents and fails within ten (10) days after the date written Notice is given by the Owner, with a copy of such Notice sent to the Contractor's Surety, to commence and continue remedy of such default or neglect with diligence and promptness, the Owner may, without prejudice to any other remedy he may have, make good such deficiencies and may further elect to complete all Work thereafter through such means as the Owner may select, including the use of a new contractor pursuant to Paragraph 3.4.2. In such case, the Owner shall provide Notice to the Contractor's Surety and an appropriate Change Order shall be issued deducting from the payments then or thereafter due the Contractor the cost of correcting such deficiencies, including compensation for the Design Consultant's additional services made necessary by such default, neglect or failure and any other damages suffered by Owner as a result of Contractor's breach, including but not limited to Owner's reasonable attorney's fees and litigation costs and expenses. If the payments then or thereafter due the Contractor are not sufficient to cover such amount, the Contractor or its Surety shall pay the difference to the Owner. Notwithstanding the Owner's right to carry out a portion of the Work, warranty, maintenance and protection of the Work remains the Contractor's and Surety's responsibility. Further, the provisions of this Paragraph do not affect the Owner's right to require the correction of defective or non-conforming Work in accordance with Section 13.2.

3.4.2 Whenever the Contractor shall be, and declared by the Owner to be in default under the Contract, the Owner having substantially performed Owner's obligations thereunder, the Surety shall promptly remedy the default, or shall be liable to Owner for damages pursuant to the Performance Bond and as provided by law. Any action by Surety or by Owner against the Surety shall not relieve Contractor of its duties, responsibilities and liabilities to Owner pursuant to the Contract or as allowed by law.

ARTICLE 4

CONTRACTOR

4.1 DEFINITION

4.1.1 The Contractor is the person or organization identified as such in the Owner-Contractor Agreement and may be referred to throughout the Contract Documents as if singular in number and masculine in gender. The term Contractor means the Contractor or his authorized representative, who shall have authority to bind the Contractor in all matters pertinent to the Contract.

4.1.2 The Contract is not one of agency by the Contractor for Owner but one in which Contractor is engaged independently in the business of providing the services and performing the Work herein described as an independent contractor.

4.2 REVIEW OF CONTRACT DOCUMENTS

4.2.1 The Contractor represents that prior to executing this Contract, the Contractor carefully reviewed and studied the Contract Documents and notified the Owner and Design Consultant of any errors, inconsistencies or omissions of which the Contractor is aware. The Contractor agrees to continuously and carefully study and compare the Contract Documents after the execution of this Contract and shall at once report to the Owner and Design Consultant any error, inconsistency or omission he may discover, including, but not limited to, any requirement which may be contrary to any law, ordinance, rule, regulation, building code, or order of any public authority bearing on the Work. If the Contractor has reported in writing an error, inconsistency or omission, has promptly stopped the affected Work until otherwise instructed, and has otherwise followed the instructions of the Owner, the Contractor shall not be liable to the Owner or the Design Consultant for any damage resulting from any such errors, inconsistencies or omissions in the Contract Documents. The Contractor shall perform no portion of the Work at any time without it being specified in Contract Documents and, where required, approved Shop Drawings, Product Data or Samples for such portion of the Work.

4.2.2 The Contractor and his Subcontractors shall keep at the site of the Work at least one copy of the Drawings and Specifications and shall at all times give the Owner, the Design Consultant, inspectors, as well as other representatives of the Owner access thereto.

4.3 SUPERVISION AND CONSTRUCTION PROCEDURES

4.3.1 The Contractor shall supervise and direct the Work, using his best skill and attention. He shall be solely responsible for and have control over all construction means, methods, techniques, sequences and procedures and for coordinating all portions of the Work under the Contract.

4.3.1.1 It shall be the Contractor's responsibility to schedule the Work; to maintain a progress schedule for the Project; and to notify the Design Consultant and the Owner of any changes in the progress schedule. He shall be responsible for providing adequate notice to all Subcontractors to insure efficient continuity of all phases of the Project. The Contractor is responsible for keeping the Owner and Design Consultant fully informed as to the work progress, including immediate notification of any work progress changes.

4.3.2 The Contractor shall be responsible to the Owner for the acts and omissions of his employees,

Subcontractors and Sub-subcontractors, Suppliers, their agents and employees, and other persons performing any of the Work and for their compliance with each and every requirement of the Contract Documents, in the same manner as if they were directly contracted by the Contractor.

- 4.3.3 The Contractor shall not be relieved from his obligations to perform the Work in accordance with the Contract Documents either by the acts, failures to act or duties of the Owner or the Design Consultant in their administration of the Contract, or by inspections, tests or approvals (or the lack thereof) required or performed under Section 7.6 by persons other than the Contractor.
- 4.3.4 Before starting a section of the Work, the Contractor shall carefully examine all preparatory work that has been executed to receive his work to see that it has been completed in accordance with the Contract Documents. He shall check carefully, by whatever means are required, to ensure that his work and adjacent, related work will finish to proper and required standards for quality, contours, planes, and levels.
- 4.3.5 The Contractor understands and agrees that the Owner and Design Consultant will not be responsible for and will not have control or charge of construction means, methods, techniques, sequences or procedures, or for safety precautions and programs in connection with the Work, and they will not be responsible for the Contractor's failure to carry out the Work in accordance with the Contract Documents. The Owner and the Design Consultant will not be responsible for or have control or charge over the acts or omissions of the Contractor, Subcontractors, or any of their agents or employees, or any other persons performing any of the Work.
- 4.3.6 The Contractor shall not use or provide Subcontractor equipment, materials, methods or persons to which Owner and Design Consultant have a reasonable objection and shall remove no portion of the Work or stored materials from the site of the Work, except for defective Work the Contractor may be required to replace or repair as set forth herein.
- 4.3.7 The Contractor shall verify all grades, lines, levels and dimensions as indicated and shown on the Drawings and in the Specifications prior to beginning any portion of the Work and shall immediately report in writing any errors or inconsistencies to the Design Consultant before commencing that portion of the Work.

4.4. CONTRACTOR'S REPRESENTATIONS

- 4.4.1 By entering into this Contract with the Owner, the Contractor represents and warrants the following, together with all other representations and warranties in the Contract Documents:
 - .1 That he is experienced in and competent to perform the type of work required and to furnish the Subcontractors, materials, supplies, equipment and services to be performed or furnished by him;
 - .2 That he is financially solvent, able to pay his debts as they mature, and possessed of sufficient working capital to initiate and complete the Work required under the Contract;
 - .3 That he is familiar with all Federal, State, County, municipal and department laws, ordinances, permits, regulations, building codes and resolutions which may in any way affect the Work or those employed therein, including but not limited to any special laws or regulations relating to the Work or any part thereof;

- .4 That such temporary and permanent Work required by the Contract Documents will be satisfactorily constructed and fit for use for its intended purpose and that such construction will not injure any person, or damage any property;
- .5 That he has carefully examined the Contract Documents and the site of the Work and that from his own investigations, he has satisfied himself and made himself familiar with: (1) the nature and location of the Work; (2) the character, quality and quantity of surface and subsurface materials likely to be encountered, including, but not limited to, all structures and obstructions on or at the Project site, both natural and man-made; (3) the character of equipment and other facilities needed for the performance of the Work; (4) the general and local conditions including without limitation its climatic conditions, the availability and cost of labor and the availability and cost of materials, tools and equipment; (5) the quality and quantity of all materials, supplies, tools, equipment, labor and professional services necessary to complete the Work in the manner required by the Contract Documents; and (6) all other matters or things which could in any manner affect the performance of the Work;
- .6 That he will fully comply with all requirements of the Contract Documents;
- .7 That he will perform the Work consistent with good workmanship, sound business practice, and in the most expeditious and economical manner consistent with the best interests of the Owner;
- .8 That he will furnish efficient business administration and experienced project management and supervision, and an adequate supply of workers, equipment, tools and materials at all times;
- .9 That he has carefully reviewed the Work required and that the Work can be planned and executed in a normal and orderly sequence of Work and reasonably scheduled so as to ensure completion of the Work in accordance with the Contract Documents, allowing for normal and reasonably foreseeable weather, labor and other delays, interruptions and disruptions of the Work;
- .10 That he will complete the Work within the Contract Time and all portions thereof within any required Completion Dates;
- .11 That his Contract Sum is based upon the labor, materials, systems and equipment required by the Contract Documents, without exception; and
- .12 That he will make a good faith effort to utilize Historically Underutilized Businesses (HUB's) per N.C. Gen. Stat. 143-128.2, and as described in the construction documents.

4.5 LABOR AND MATERIALS

- 4.5.1 Unless otherwise provided in the Contract Documents, the Contractor shall provide and pay for all labor, materials, equipment, supplies, tools, construction equipment and machinery, water, heat, utilities, transportation, and other facilities and services necessary or proper for or incidental to the execution and completion of the Work required by and in accordance with the Contract Documents and any applicable code or statute, whether specifically required by the Contract Documents or whether their provision may reasonably be inferred as necessary to produce the intended results, whether temporary or permanent and whether or not incorporated

or to be incorporated in the Work. Final payment will not be made until the Work is so completed and Contractor has otherwise complied with the Contract Documents in full.

4.5.2 The Contractor shall at all times enforce strict discipline and good order among his employees and Subcontractors performing any of the Work and shall not employ or contract with on the Work any unfit person or entity or anyone not skilled in the task assigned to him. The Owner may, by Notice, require the Contractor to remove from the Work any employee or employee of a Subcontractor performing any of the Work, that the Owner deems incompetent, careless or otherwise objectionable.

4.5.3 The Contractor shall be responsible for ensuring that the Work is completed in a skillful and workmanlike manner.

4.5.4 All equipment, apparatus and/or devices of any kind to be incorporated into the Work that are shown or indicated on the Drawings or called for in the Specifications or required for the completion of the Work shall be entirely satisfactory to the Owner and the Design Consultant as regards operations, capacity and/or performance. No approval, either written or verbal, of any drawings, descriptive data or samples of such equipment, apparatus and/or device shall relieve the Contractor of his responsibility to turn over the same in good working order for its intended purpose at the completion of the Work in complete accordance with the Contract Documents. Any equipment, apparatus and/or device not fulfilling these requirements shall be removed and replaced by proper and acceptable equipment, etc. or put in good working order satisfactory to the Owner and Design Consultant without additional cost to the Owner.

4.6 WARRANTY

4.6.1 The Contractor warrants to the Owner and the Design Consultant that all materials and equipment furnished under this Contract will be new unless otherwise specified, and that all workmanship will be in accordance with generally accepted industry standards, free from faults and defects and in conformance with the Contract Documents and all other warranties and guaranties specified therein. Where no standard is specified for such workmanship or materials, they shall be the best of their respective kinds. All Work not conforming to these requirements, including substitutions not properly approved and authorized, may be considered defective. If required by the Owner or the Design Consultant, the Contractor shall furnish satisfactory evidence as to the kind and quality of materials and equipment. This warranty is not limited by the provisions of Article 13.

4.6.2 The Contractor will be required to complete the Work specified and to provide all items needed for construction of the Project, complete and in good order.

4.6.3 The warranties set forth in this Section 4.6 and elsewhere in the Contract Documents shall survive Final Completion of the Work under Section 9.9.

4.6.4 The Contractor guarantees and warrants to the Owner all Work as follows:

- .1 That all materials and equipment furnished under this Contract will be new and the best of its respective kind unless otherwise specified;
- .2 That all Work will be in accordance with generally accepted industry standards and free of omissions and faulty, poor quality, imperfect and defective material or workmanship;
- .3 That the Work shall be entirely watertight and leak proof in accordance with all applicable

industry customs and practices, and shall be free of shrinkage and settlement;

- .4 That the Work, including but not limited to, mechanical and electrical machines, devices and equipment, shall be fit and fully usable for its intended and specified purpose and shall operate satisfactorily with ordinary care;
 - .5 That consistent with requirements of the Contract Documents, the Work shall be installed and oriented in such a manner as to facilitate unrestricted access for the operation and maintenance of fixed equipment;
 - .6 That the Work will be free of abnormal or unusual deterioration which occurs because of poor quality materials, workmanship or unsuitable storage; and
 - .7 That the products or materials incorporated in the Work will not contain asbestos.
- 4.6.5 All Work not conforming to guarantees and warranties specified in the Contract Documents, including substitutions not properly approved and authorized, may be considered defective. If required by the Design Consultant or Owner, the Contractor shall furnish satisfactory evidence as to the kind and quality of materials and equipment.
- 4.6.5.1 The Contractor will submit a written affidavit certifying that none of the materials incorporated in the Project contain asbestos.
- 4.6.6 If, within one (1) year after the date of Substantial Completion of the Work or designated portion thereof as defined in Paragraph 8.1.3 or within such longer period of time as may be prescribed by law or by the terms of any applicable special warranty required by the Contract Documents, any of the Work is found to be defective, not in accordance with the Contract Documents, or not in accordance with the guarantees and warranties specified in the Contract Documents, the Contractor shall correct it within five (5) working days or such other period as mutually agreed, after receipt of Notice from the Owner to do so. The Owner shall give such Notice with reasonable promptness after discovery of the condition. For items that remain incomplete or uncorrected on the date of Substantial Completion, the one (1) year warranty shall begin on the date of Final Completion of the Work or upon correction of the defective Work.
- 4.6.7 If at any time deficiencies in the Work are discovered which are found to have resulted from fraud or misrepresentation, or an intent or attempt to or conspiracy to defraud the Owner by the Contractor, any Subcontractor or Supplier, the Contractor will be liable for replacement or correction of such Work and any damages which Owner has incurred related thereto, regardless of the time limit of any guarantee or warranty.
- 4.6.8 Any materials or other portions of the Work, installed, furnished or stored on site which are not of the character or quality required by the Specifications, or are otherwise not acceptable to the Design Consultant or the Owner, shall be immediately removed and replaced by the Contractor to the satisfaction of the Design Consultant and Owner, when notified to do so by the Design Consultant or Owner.

- 4.6.9 If the Contractor fails to correct defective or non-conforming Work as required by Paragraph 4.6.6, or if the Contractor fails to remove defective or non-conforming Work from the site, as required by Paragraph 4.6.8, the Owner may elect to either correct such Work in accordance with Section 3.4 or remove and store materials and equipment at the expense of the Contractor. If the Contractor does not pay the cost of such removal and storage within ten (10) days thereafter, the Owner may upon ten (10) additional days written Notice sell such Work at auction or at private sale and shall account for the net proceeds thereof, after deducting all the costs that should have been borne by the Contractor, including compensation for the Design Consultant's additional services and Owner's reasonable attorney's fees made necessary thereby. If such proceeds of sale do not cover all costs, which the Contractor should have borne, the difference shall be charged to the Contractor and an appropriate Change Order shall be issued. If the payments then or thereafter due the Contractor are not sufficient to cover such amount, the Contractor shall pay the difference to the Owner.
- 4.6.10 The Contractor shall bear the cost of making good all of the Work of the Owner, Separate Contractors or others, destroyed or damaged by such correction or removal required under this Article 4, Article 13 or elsewhere in the Contract Documents.
- 4.7 TAXES
- 4.7.1 The Contractor shall pay all sales, consumer, use and other similar taxes for the Work or portions thereof provided by the Contractor which are legally enacted at the time the Owner received bids for the construction of the Project, whether or not yet effective.
- 4.7.2 Sales and Use Tax. Contractor shall be responsible for complying with any applicable sales and use tax obligations imposed by Chapter 105, Article 5 of the North Carolina General Statutes. Where Contractor has been contracted with to oversee "new construction" or "reconstruction" as defined in G.S. 105-164.4H, Contractor shall be responsible for issuing and maintaining an Affidavit of Capital Improvement.
- 4.8 PERMITS, FEES AND NOTICES
- 4.8.1 The Owner shall be responsible for fees associated with permits and approval of the Drawings including but not limited to building permit, utility impact fees, stormwater permit and driveway permit.
- 4.8.2 The Contractor is responsible for all fees, permits and other costs associated with temporary utilities, including but not limited to installation, use, disconnection, removal and/or relocation.
- 4.8.3 The Contractor will pay for his own license, inspection and re-inspection fees for the proper execution and completion of the Work.
- 4.8.4 The Contractor shall give all notices and comply with all laws, ordinances, rules, regulations and lawful orders of any public authority bearing on the performance of the Work, including but not limited to all applicable building codes. If Contractor believes that any part of the Drawings or Specifications are inconsistent with applicable laws, rules, regulations, lawful orders of public authorities or building codes, Contractor shall Notify the Owner and Design Consultant of such inconsistencies immediately.
- 4.9 ALLOWANCES

4.9.1 The Contractor shall include in the Contract Sum all Allowances stated in the Contract Documents. Items covered by these Allowances shall be supplied for such amount and by such persons as the Owner may direct, but the Contractor will not be required to employ persons against whom he makes a reasonable objection.

4.9.2 Unless otherwise provided in the Contract Documents:

- .1 Allowances for Work: These allowances shall cover the cost to the Contractor for the materials and equipment required by the allowance delivered at the site, all applicable taxes, unloading, uncrating and storage, protection from elements, labor, installation and finishing and other expenses required to complete the installation, and a fixed percentage for overhead and profit as defined in Article 12.
- .2 Allowances for Products/Materials: Allowance includes the cost of the product, delivery to the site and applicable taxes. The Contractor's costs for unloading and handling on the site, labor, installation, overhead, profit and other expenses contemplated for the material allowance shall be included in the Contract Sum and not in the allowance;
- .3 Whenever the cost is more than or less than the Allowance, the Contract Sum shall be adjusted accordingly by Change Order, the amount of which will recognize changes, if any, in handling costs on the site, labor, installation costs, overhead, profit and other expense.

4.10 SUPERINTENDENT

4.10.1 The Contractor shall employ, and have approved by the Owner, a competent superintendent and necessary assistants who shall be in attendance at the Project site during the progress of the Work. The superintendent shall represent the Contractor and all communications given to the superintendent shall be as binding as if given to the Contractor. If the Contractor employs more than a single individual in this role, the Owner shall be provided an organizational chart and personnel listing for the staff performing the functions of a superintendent. In such event, all references to the superintendent elsewhere in the Contract Documents shall mean the staff performing the functions of a superintendent.

4.10.2 The superintendent shall be in attendance at the Project site not less than eight (8) hours per day, five (5) days per week, unless the job is closed down due to conditions beyond the control of the Contractor or until termination of the Contract in accordance with the Contract Documents. It is understood that such superintendent shall be acceptable to the Owner and shall be the one who will be continued in that capacity for the duration of the Project, unless he ceases to be on the Contractor's payroll or the Owner otherwise agrees. The superintendent shall not be employed on any other project for or by Contractor or any other entity during the course of the Work.

4.11 PROGRESS SCHEDULE

4.11.1 The Contractor shall prepare and submit to the Owner for the Owner's review and approval an estimated progress schedule for the Work.

4.12 RESPONSIBILITY FOR COMPLETION

4.12.1 The Contractor shall furnish such manpower, materials, facilities and equipment and shall work within the normal scheduled working hours to ensure the performance of the Work within the Completion Dates specified in the Owner-Contractor Agreement. If for any reason the

Contractor must work outside of the normal scheduled working hours, a custodian employed by the Owner is required to be in attendance when accessing the work area. The Contractor agrees to reimburse the Owner for such custodian's time. The reimbursement is due with the subsequent payment application.

- 4.12.2 If it becomes apparent to the Design Consultant or Owner that the Work will not be completed within required Completion Dates, the Contractor agrees to undertake some or all of the following actions, at no additional cost to the Owner, in order to ensure, in the opinion of the Design Consultant and Owner, that the Contractor will comply with all Completion Date requirements:
- .1 Increase manpower, materials, crafts, equipment and facilities;
 - .2 Increase the number of working hours per shift, shifts per working day, working days per week, or any combination of the foregoing, including but not limited to night shifts, overtime operations and Sundays and holidays;
 - .3 Reschedule activities to achieve maximum practical concurrence of accomplishment of activities;
 - .4 Require that his superintendent be at the Project site not less than ten (10) hours per day, six (6) days per week; and
 - .5 Reimburse the Owner in accordance with Paragraph 4.12.1 above for all work performed outside of the normal scheduled work hours.
- 4.12.3 In undertaking the actions required under Paragraph 4.12.1, Contractor shall prepare and adhere to a recovery schedule if the Project is behind schedule by four (4) or more days.
- 4.12.4 If the actions taken by the Contractor are not satisfactory, the Design Consultant or Owner may direct the Contractor to take any and all actions necessary to ensure completion within the required Completion Dates, without additional cost to the Owner. In such event, the Contractor shall continue to assume responsibility for his performance and for completion within the required dates.
- 4.12.5 If, in the opinion of the Design Consultant or Owner, the actions taken by the Contractor pursuant to this Article or the progress or sequence of the Work are not accurately reflected on the construction schedule, the Contractor shall revise such schedule to accurately reflect the actual progress and sequence of the Work.
- 4.12.6 Failure of the Contractor to substantially comply with the requirements of this Article, may be considered grounds for a determination by the Owner, pursuant to Article 14, that the Contractor is failing to prosecute the Work with such diligence as will ensure its completion within the time specified.
- 4.12.7 The Owner may, at its sole discretion and for any reason, other than due to the fault of Contractor require the Contractor to accelerate the Work by providing overtime, Saturday, Sunday and/or holiday work and/or by having all or any Subcontractors designated by the Owner provide overtime, Saturday, Sunday, and/or holiday work. In the event that the Owner requires such acceleration a Change Order shall be issued in accordance with Article 12.
- 4.12.8 This Section 4.12 does not eliminate the Contractor's responsibility to comply with the local

noise ordinances, all highway permit requirements and all other applicable laws, regulations, rules, ordinances, resolutions, and permit requirements.

4.13 DOCUMENTS AND SAMPLES AT THE SITE

4.13.1 The Contractor shall maintain at the site for the Owner one record copy of all Drawings, Specifications, Addenda, Change Orders and other Modifications, in good order and marked currently to record all changes made during construction, and approved Shop Drawings, Product Data and Samples. These shall be delivered to the Design Consultant upon completion of the Work.

4.14 SHOP DRAWINGS, PRODUCT DATA AND SAMPLES

4.14.1 Shop Drawings are drawings, diagrams, schedules and other data specially prepared for the Work by the Contractor or any Subcontractor, Manufacturer, Supplier or distributor to illustrate some portion of the Work.

4.14.2 Product Data are illustrations, standard schedules, performance charts, instructions, brochures, diagrams and other information furnished by the Contractor to illustrate a material, product or system for some portion of the Work.

4.14.3 Samples are physical examples, which illustrate materials, equipment or workmanship and establish standards by which the Work will be judged.

4.14.4 Manuals are manufacturer's installation, start-up, operating, and maintenance and repair instructions together with parts lists, pictures, sketches and diagrams, which set forth the manufacturer's requirements for the benefit of the Contractor and the Owner.

4.14.5 The Contractor shall prepare or have prepared at its expense and shall review, indicate approval thereupon, and submit, with reasonable promptness and in such sequence as to cause no delay in the Work or in the other work of the Owner or any Separate Contractor, all Shop Drawings, Product Data, Manuals and Samples required by the Contract Documents.

4.14.5.1 Unless otherwise directed in writing, the Contractor shall submit no less than three (3) copies of each Shop Drawing, Product Data, or Manuals to the Design Consultant. Routing of said submittals will be from the Contractor to the Design Consultant with a copy of the transmittal to the Owner. The Design Consultant will return one (1) copy of the reviewed submittal to the Contractor.

4.14.5.2 Where the Contract calls for the submittal of manufacturer's data to the Design Consultant for information only, such submittals shall be made before the commencement of any portion of the Work requiring such submission. Work performed without benefit of approved Shop Drawings for any portion of the Work is subject to removal and replacement at no cost to the Owner.

4.14.5.3 For standard manufactured items not requiring special Shop Drawings for manufacture, Contractor shall submit no less than three (3) copies of Manufacturer's catalogue sheets showing illustrated cuts of item to be furnished, scale details, sizes, dimensions, performance characteristics, capacities, wiring diagrams and controls, and all other pertinent information. One (1) copy of reviewed submissions will be returned to the Contractor.

4.14.5.4 Unless otherwise directed in writing, all other Shop Drawings, Contractor shall submit no less

than three (3) legible copies of each drawing. Each drawing shall have a clear space for stamps. When phrase "by others" appears on Shop Drawings, the Contractor shall indicate on the Shop Drawing who is to furnish material or operations so marked before submittal. When the Shop Drawings are checked "revise and resubmit", the Contractor shall make corrections and submit new copies for review. The Shop Drawings shall contain the Contractor's "approval" and corrections.

- 4.14.5.5 For use of all trades, the Contractor shall provide such number of Shop Drawings as is required for field distribution.
- 4.14.5.6 The Design Consultant will review submittals and make marks to indicate corrections or revisions required and will stamp each submittal with an action stamp and will mark the stamp with the action required by the Contractor.
- 4.14.5.7 Contractor shall submit names of proposed Manufacturers, Material Suppliers, dealers, who are to furnish materials, fixtures, appliances or other fittings for approval as early as possible, to afford proper investigation and checking.
- 4.14.5.8 Transactions with manufacturers, or Subcontractors, shall be through Contractor.
- 4.14.5.9 Unless otherwise specified, Contractor shall submit samples in duplicate of adequate size showing quality, type, color range, finish, and texture as indicated in the Specifications.
- 4.14.5.10 Where Specifications require manufacturer's printed installation instructions, Contractor shall submit duplicate copies of such instructions for approval.
- 4.14.5.11 When several materials are specified by name for one use, Contractor shall select for use any of those so specified.
- 4.14.5.12 Whenever item or class of material is specified exclusively by trade name, manufacturer's name, or by catalogue reference, Contractor shall use only such item, unless written approval for substitution is secured, as outlined in the Specifications and in Section 4.15 of the General Conditions.
- 4.14.5.13 Contractor shall not order materials until receipt of written approval. Contractor shall furnish materials equal in every respect to approved samples.
- 4.14.6 By approving and submitting Shop Drawings, Product Data, Manuals and Samples, the Contractor represents that he has determined and verified all materials, field measurements, and field construction criteria related thereto, and that he has checked and coordinated the information contained within such submittals with the requirements of the Work and of the Contract Documents. The Contractor shall adhere to any supplementary processing and scheduling instructions pertaining to Shop Drawings, which may be issued by the Design Consultant.
- 4.14.6.1 Parts and details not fully indicated on the Drawings shall be detailed by the Contractor in accordance with standard engineering practice. Dimensions on the Drawings, as well as detailed drawings themselves are subject in every case to measurements of existing, adjacent, incorporated and completed, which shall be taken by the Contractor before undertaking any Work dependent on such data.
- 4.14.7 The Contractor shall not be relieved of responsibility for any deviation from the requirements

of the Contract Documents by the Design Consultant's review of Shop Drawings, Product Data, Samples or Manuals under Paragraph 2.2.14 unless the Contractor has specifically informed the Design Consultant in writing of such deviation at the time of submission and the Design Consultant has given written approval to the specific deviation. The Contractor shall not be relieved from responsibility to Owner for errors or omissions in the Shop Drawings, Product Data, Samples, or Manuals by virtue of the Design Consultant's review or approval thereof.

- 4.14.8 The Contractor shall make corrections required by the Design Consultant and shall resubmit the required number of corrected copies of Shop Drawings or new Product Data or Samples. The Contractor shall direct specific attention, in writing on resubmitted Shop Drawings, Product Data or Samples or Manuals, to revisions other than those requested by the Design Consultant on previous submittals. Re-submittals necessitated by required corrections due to Contractor's errors or omissions shall not be cause for extension of Contract Time or an increase in the Contract Sum.
- 4.14.8.1 No portion of the Work requiring submission of Shop Drawings, Product Data, Samples or Manuals shall be commenced until the submittal has been approved by the Design Consultant as provided in Article 2. All such portions of the Work shall be in accordance with approved submittals.
- 4.14.9 Shop Drawings, Product Data and Samples shall be dated and shall bear the name of the Project; a description or the names or equipment, materials and items; and complete identification of locations at which materials or equipment are to be installed. Shop Drawings shall be stamped and signed stating that the Contractor has determined and verified all materials, field measurements, and field construction criteria related thereto and that he has checked and coordinated the information contained within such submittals with the requirements of the Work and of the Contract Documents.
- 4.14.10 Submittals of Shop Drawings, Product Data, Samples or Manuals shall be accompanied by a transmittal letter, in duplicate, containing the name of the Project, the Contractor's name, the number of Shop Drawings, Product Data, Samples, or Manuals, identification of Specification section and other pertinent data.
- 4.15 EQUAL PRODUCTS AND SUBSTITUTIONS
- 4.15.1 All materials, supplies and articles furnished under the Contract shall, whenever specified and otherwise practicable, be the standard products of recognized, reputable manufacturers. Unless otherwise specifically provided in the Contract Documents, the naming of a certain brand, make, manufacturer or article, device, product, material, fixture or type of construction shall convey the general style, type, character and standard of quality of the article desired and shall not be construed as limiting competition. The Contractor, in such cases, may with Owner's written approval, use any brand, make, manufacturer, article, device, product, material, fixture, form or type of construction which in the judgment of the Design Consultant is equal to that specified. An item may be considered equal to the item so named or described if, in the opinion of the Owner and Design Consultant (1) it is at least equal in quality, durability, appearance, strength, and design; (2) it will perform at least equally the specific function imposed by the general design for the Work being contracted for or the material being purchased; and (3) it conforms substantially, even with deviations, to the detailed requirements for the item in the Specifications. Approval by the Owner and Design Consultant will be granted based upon considerations of quality, workmanship, economy of operation, suitability for the purpose intended, warranty and acceptability for use on the Project.

4.15.2 To obtain such approval on makes or brands of material other than those specified in Contract Documents, and not previously approved at the time the Owner received bids for the construction of the Project, the Contractor's request for approval of any substitution shall include:

- .1 Complete data substantiating compliance of the proposed substitution with the Contract Documents;
- .2 Product identification including manufacturers' name, address, and phone number;
- .3 Manufacturer's literature showing complete product description, performance and test data, and all reference standards;
- .4 Samples and colors in the case of articles or products;
- .5 Names and addresses of similar projects on which the product was used and date of installation;
- .6 For construction methods, include a detailed description for the proposed method and drawings illustrating same;
- .7 Itemized comparison of proposed substitution with product or method specified and any cost reduction, which shall benefit the Owner;
- .8 Accurate cost data on proposed substitution in comparison with product or method specified;
- .9 All directions, specifications, and recommendations by manufacturers for installation, handling, storing, adjustment, and operation; and
- .10 Item by item comparison of characteristics of substitution item with those items specified.

4.15.3 The Contractor shall also submit with his request for approval a sworn and notarized statement which shall include all of the following representations by the Contractor, namely that:

- .1 He has investigated the proposed product or method and determined that it is equal or better in all respects to that specified and that it fully complies with all requirements of the Contract Documents;
- .2 He will meet all contract obligations with regard to this substitution;
- .3 He will coordinate installation of accepted substitutions into the Work, making all such changes and any required schedule adjustments, at no additional cost to the Owner, as may be required for the Work to be complete in all respects;
- .4 He waives all Claims for additional costs and additional time related to substitutions, which consequently become apparent. He also agrees to hold the Owner harmless from Claims for extra costs and time incurred by other Subcontractors and suppliers, or additional services which may have to be performed by the Design Consultant, for changes for extra work that may, at some later date, be determined to be necessary in order for the Work to function in the manner intended in the Contract Documents;

- .5 He will provide the same warranty and guarantee, and perform any work required in accordance therewith, for the substitution that is applicable to the specified item for which the substitution is requested;
- .6 Material will be installed, handled, stored, adjusted, tested, and operated in accordance with the manufacturers' recommendation and as specified in the Contract Documents.
- .7 In all cases new materials will be used unless this provision is waived by Notice from the Owner or his Design Consultant, or unless otherwise specified in the Contract Documents;
- .8 All material and workmanship will be in every respect in accordance with that which, in the opinion of the Owner or Design Consultant, is in conformity with approved modern practice; and
- .9 He has provided accurate cost data on the proposed substitution in comparison with the product or method specified.

4.15.4 Subject to the provisions of any applicable laws, approval for substitutions or equal products shall be at the sole discretion of the Owner, shall be in writing to be effective, and the decision of the Owner shall be final. The Owner or Design Consultant may require tests of all materials proposed for substitution so submitted to establish quality standards, at the Contractor's expense. After approval of a substitution, if it is determined that the Contractor submitted defective information or data regarding the substitution upon which Owner's approval was based, and that unexpected or un contemplated extensive redesign or rework of the Project will be required in order to accommodate the substitution, or that the substituted item will not perform or function as well as the specified item for which substitution was requested, the Contractor will be required to furnish the original specified item or obtain approval to use another substitution; the Contractor shall pay all costs, expenses or damages associated with or related to the unacceptability of such a substitution and the resultant utilization of another item and no time extension shall be granted for any delays associated with or related to such substitution.

4.15.5 If a substitution is approved, no further change in brand or make will be permitted unless satisfactory, written evidence is presented to and approved by the Owner that the manufacturer cannot make scheduled delivery of the approved substituted item. The Owner will not consider substitutions for approval if:

- .1 The proposed substitution is indicated or implied on the Contractor's Shop Drawing or product data submittal and has not been formally submitted for approval by the Contractor in accordance with the above-stated requirements, or
- .2 Acceptance of the proposed substitution will require substantial design revisions to the Contract Documents or is otherwise not acceptable to the Owner and Design Consultant.

4.15.6 Except as otherwise provided for by the provisions of any applicable laws, the Contractor shall not have any right of appeal from the decision of the Owner rejecting any materials submitted if the Contractor fails to obtain the approval for substitution under this Article.

4.16 USE OF SITE

4.16.1 The Contractor shall confine operations at the site to areas permitted by law, ordinances, permits, easements, right-of-way agreements and within the limits of construction as shown on the Contract Documents. The Contractor shall not unreasonably encumber the site, in the opinion of the Owner, with any materials, equipment or trailers nor shall he block the entrances or otherwise prevent reasonable access to the site, other working and parking areas, completed portions of the Work and/or properties, storage areas, areas of other facilities that are adjacent to the worksite. If the Contractor fails or refuses to move said material, equipment or trailers within twenty four (24) hours of notification by the Owner, to so do, the Owner shall have the right, without further notice, to remove, at the Contractor's expense, any material, equipment and/or trailers which the Owner deems are in violation of this Paragraph.

4.17 CUTTING AND PATCHING OF WORK

4.17.1 The Contractor shall be responsible for all cutting, fitting or patching that may be required to complete the Work or to make its several parts fit together properly and in accordance with the Contract Documents.

4.17.2 The Contractor shall not damage or endanger any portion of the Work or the work of the Owner or any Separate Contractors by cutting, patching or otherwise altering any work, or by excavation. The Contractor shall not cut or otherwise alter the work of the Owner or any Separate Contractor except with the written consent of the Owner and of such Separate Contractor. The Contractor shall not unreasonably withhold from the Owner or any Separate Contractor his consent to cutting or otherwise altering the Work. The Owner shall not be required to accept work with a cut, splice, or patch when such cut, splice or patch is not generally accepted practice for the particular work involved or is otherwise unworkmanlike in the opinion of the Design Consultant or the Owner.

4.17.3 Existing structures and facilities including but not limited to building, utilities, topography, streets, curbs, walks, etc., that are damaged or removed due to required excavations or other construction work, shall be patched, repaired or replaced by the Contractor to satisfaction of the Design Consultant and the Owner of such structures and facilities and authorities having jurisdiction. In event the local jurisdictional authorities require that such repairing and patching be done with their own labor and materials, the Contractor shall abide by such regulations and pay for such work with no increase in the Contract Sum.

4.18 CLEANING UP

4.18.1 The Contractor at all times shall keep the premises free from accumulation of waste materials or rubbish caused by his operations. At the completion of the Work and before final payment is made, he shall remove all his waste materials and rubbish from and about the Project as well as all his tools, construction equipment, machinery and surplus materials.

4.18.2 If the Contractor fails to clean up during or at the completion of the Work, the Owner may do so as provided in Section 6.3 and the cost thereof shall be charged to the Contractor.

4.19 COMMUNICATIONS

4.19.1 All communications from the Contractor relating to the Contract Documents or the construction schedule will be directed to the Design Consultant and copied to the Owner. Similarly, all correspondence from the Owner or Design Consultant will be directed to the Contractor and

copied to the Owner or Design Consultant.

4.20 ROYALTIES AND PATENTS

4.20.1 The Contractor shall pay all royalties and license fees. He shall defend all suits or claims for infringement of any patent rights arising out of the Work and shall save the Owner harmless from loss on account thereof.

4.21 INDEMNIFICATION

4.21.1 To the fullest extent permitted by law, the Contractor shall, at its sole cost and expense, indemnify, defend, and hold harmless the Owner and its agents, representatives, and employees from and against all claims, actions, judgments, costs, liabilities, penalties, damages, losses and expenses, including but not limited to attorneys' fees, arising out of and/or resulting from the performance of the Work, provided that any such claim, action, judgment, cost, liability, penalty, damage, loss or expense is caused by any negligent act, error or omission of the Contractor, any Subcontractor or anyone directly or indirectly employed by any of them or anyone for whose acts any of them may be legally liable. The above obligation shall not be construed to negate, abridge, or otherwise reduce any other right or obligation of indemnity which would otherwise exist as to any party or person described in this Section 4.21.1. The parties agree that this indemnification clause is an "evidence of indebtedness" for purpose of N.C. Gen. Stat. § 6-21.2. The parties also specifically acknowledge that the Owner is a public body and it is the intent of the parties that the Owner not incur any expenses when the Contractor is solely responsible for the claims.

4.21.2 In any and all claims against the Owner or the Design Consultant or any of their agents, representatives, or employees by any employee of the Contractor, any Subcontractor, anyone directly or indirectly employed by any of them or anyone for whose acts any of them may be liable, the indemnification obligation under this Section 4.21 shall not be limited in any way by any limitation on the amount or type of damages, compensation or benefits payable by or for the Contractor or any Subcontractor under workers' or workmen's compensation acts, disability benefit acts or other employee benefit acts.

4.21.3 No provision of this Section 4.21 shall give rise to any duties on the part of the Design Consultant or the Owner, or any of their agents, representatives, or employees.

4.22 PERSONS AUTHORIZED TO SIGN DOCUMENTS

4.22.1 The Contractor, within five (5) days after the earlier of the date of a Notice to Proceed or the date of the Owner-Contractor Agreement, shall file with the Owner a list of all persons who are authorized to sign documents such as contracts, certificates, and affidavits on behalf of the Contractor and to fully bind the Contractor to all the conditions and provisions of such documents, except that in the case of a corporation he shall file with the Owner a certified copy of a resolution of the Board of Directors of the corporation in which are listed the names and titles of corporation personnel who are authorized to sign documents on behalf of the corporation and to fully bind the corporation to all the conditions and provisions of such documents.

4.23 CONDITIONS AFFECTING THE WORK

4.23.1 The Contractor shall be responsible for taking all steps necessary to ascertain the nature and location of the Work and the general and local conditions that can affect the Work or the cost

thereof. Failure by the Contractor to fully acquaint himself with conditions which may affect the Work, including, but not limited to conditions relating to transportation, handling, storage of materials, availability of labor, water, roads, weather, topographic and subsurface conditions, Multi-Prime Contract conditions, applicable provisions of law, and the character and availability of equipment and facilities needed prior to and during the execution of the Work, shall not relieve the Contractor of his responsibilities under the Contract Documents and shall not constitute a basis for an adjustment in the Contract Sum or the Contract Time under any circumstances. The Owner assumes no responsibility for any understanding or representation about conditions affecting the Work made by any of his officers, employees, representatives, or agents prior to the execution of the Contract, unless such understandings or representations are expressly stated in the Contract Documents.

- 4.23.2 If in the execution of the Work any valuable items or materials of any kind are discovered buried or hidden within the Work, such items or materials shall be the property of the Owner. The Contractor shall take reasonable precautions to prevent any persons from removing or damaging such items or materials and shall immediately upon discovery thereof and before removal, acquaint the Owner or the Design Consultant with such discovery and carry out, at the expense of the Owner, the Owner's or the Design Consultant's orders as to disposal of the same.

4.24 COMPLIANCE WITH BOARD POLICIES AND PROCEDURES

The Contractor acknowledges that Board policies are available for review at the Owner's website and agrees to comply with the policies. The Contractor also agrees to comply with the following provisions:

- 4.24.1 The Contractor, its Subcontractors and employees shall not possess or carry, whether openly or concealed, any gun, rifle, pistol, or explosive on any property owned by the Owner. This includes firearms locked in containers, vehicles or firearm racks within vehicles. The Contractor, its Subcontractors and employees shall not cause, encourage or aid a minor, who is less than 18 years old to possess or carry, whether openly or concealed, any weapons on any property owned by the Owner.
- 4.24.2 The Contractor, its Subcontractors and employees, are prohibited from profane, lewd, obscene or offensive conduct or language, including engaging in sexual harassment.
- 4.24.3 The Contractor and its Subcontractors shall not manufacture, transmit, conspire to transmit, possess, use or be under the influence of any alcoholic or other intoxicating beverage, narcotic drug, hallucinogenic drug, amphetamine, barbiturate, marijuana or anabolic steroids, or possess, use, transmit or conspire to transmit drug paraphernalia on any property owned by the Owner.
- 4.24.4 The Contractor and its Subcontractors may not at any time use or display tobacco or nicotine-containing products, including but not limited to electronic cigarettes (e-cigarettes), on school premises, both indoor and outdoor. The prohibition of the display of tobacco or nicotine products shall not extend to a display that has a legitimate instructional or pedagogical purpose. For purposes of this Contract, "tobacco product" is defined to include cigarettes, cigars, blunts, bidis, pipes, chewing tobacco, snuff, and any other items containing or reasonably resembling tobacco, tobacco products, or any facsimile thereof. "Tobacco use" includes smoking, chewing, dipping, or any other use of tobacco products.

- 4.24.5 The Contractor, its Subcontractors and employees shall not solicit from or sell to students or staff within the Owner's facilities or campuses, and shall not give gifts of any value to school system employees.
- 4.24.6 Operators of all commercial vehicles on any property owned by the Owner shall be subject to post-accident, random, reasonable suspicion and follow-up testing for drugs and alcohol.
- 4.24.7 The Contractor, its Subcontractors and employees are prohibited from using access to the site pursuant to this Agreement as a means to date, court, or enter into a romantic or sexual relationship with any student enrolled in the Owner's schools. The Contractor agrees to indemnify the Owner for claims against the Owner resulting from relationships which have occurred or may occur between a student and an employee of the Contractor or Subcontractor.
- 4.24.8 Lunsford Act/Criminal Background Checks. The Contractor shall conduct at its own expense sexual offender registry checks on each of its owners, employees, agents, or Subcontractors ("contractual personnel") who will engage in any service on or delivery of goods to school system property or at a school-system sponsored event, except checks shall not be required for individuals who are solely delivering or picking up equipment, materials, or supplies at: (1) the administrative office or loading dock of a school; (2) non-school sites; (3) schools closed for renovation; or (4) school construction sites.. The checks shall include at a minimum checks of the State Sex Offender and Public Protection Registration Program, the State Sexually Violent Predator Registration Program, and the National Sex Offender Registry ("the Registries"). For the Contractor's convenience only, all of the required registry checks may be completed at no cost by accessing the United States Department of Justice Sex Offender Public Website at [http:// www.nsopw.gov/](http://www.nsopw.gov/). The Contractor shall provide certification that the registry checks were conducted on each of its contractual personnel providing services or delivering goods under this Agreement prior to the commencement of such services or the delivery of such goods. The Contractor shall conduct a current initial check of the registries (a check done more than 30 days prior to the date of this Agreement shall not satisfy this contractual obligation). In addition, Contractor agrees to conduct the registry checks and provide a supplemental certification before any additional contractual personnel are used to deliver goods or provide services pursuant to this Agreement. Contractor further agrees to conduct annual registry checks of all contractual personnel and provide annual certifications at each anniversary date of this Agreement. Contractor shall not assign any individual to deliver goods or provide services pursuant to this Agreement if said individual appears on any of the listed registries. Contractor agrees that it will maintain all records and documents necessary to demonstrate that it has conducted a thorough check of the registries as to each contractual personnel, and agrees to provide such records and documents to the school system upon request. Contractor specifically acknowledges that the school system retains the right to audit these records to ensure compliance with this Section at any time in the school system's sole discretion. Failure to comply with the terms of this provision shall be grounds for immediate termination of the Agreement. In addition, the Owner may conduct additional criminal records checks at the Owner's expense. If the school system exercises this right to conduct additional criminal records checks, Contractor agrees to provide within seven (7) days of request the full name, date of birth, state of residency for the past ten years, and any additional information requested by the school system for all contractual personnel who may deliver goods or perform services under this Agreement. Contractor further agrees that it has an ongoing obligation to provide the school system with the name of any new contractual personnel who may deliver goods or provide services under the Agreement. The Owner reserves the right to prohibit any contractual personnel of Contractor from delivering goods or providing services under this Agreement if

the Owner determines, in its sole discretion, that such contractual personnel may pose a threat to the safety or well-being of students, school personnel or others.

- 4.24.9 Contractor shall not employ any individuals to provide services to the Owner who are not authorized by federal law to work in the United States. Contractor represents and warrants that it is aware of and in compliance with the Immigration Reform and Control Act and North Carolina law (Article 2 of Chapter 64 of the North Carolina General Statutes) requiring use of the E-Verify system for employers who employ twenty-five (25) or more employees and that it is and will remain in compliance with these laws at all times while providing services pursuant to this Agreement. Contractor shall also ensure that any of its Subcontractors (of any tier) will remain in compliance with these laws at all times while providing subcontracted services in connection with this Agreement. Contractor is responsible for providing affordable health care coverage to all of its full-time employees providing services to the School System. The definitions of “affordable coverage” and “full-time employee” are governed by the Affordable Care Act and accompanying IRS and Treasury Department regulations.
- 4.24.10 The Contractor, its Subcontractors and employees shall not interact with any students. Nothing in Paragraph 4.24 shall be construed to prevent the Contractor, its Subcontractors and employees from taking necessary measures to protect students, staff or other employees.
- 4.24.11 The Contractor shall at all times enforce strict discipline and good order among its employees and shall not employ any unfit person or anyone not skilled in the task assigned to it. The Owner may require the Contractor to remove any employee the Owner deems incompetent, careless or otherwise objectionable.
- 4.24.12 All agents and workers of the Contractor and its Subcontractors shall wear identification badges provided by the Contractor at all times they are on the Owner’s property. The identification badges shall at a minimum display the company name, telephone number, employee name and a picture of the employee.
- 4.24.13 The Contractor shall comply with the Owner’s site or school building access procedures when working on any existing school campus.
- 4.24.14 Anti-Nepotism. The Contractor warrants that, to the best of its knowledge and in the exercise of due diligence, none of its corporate officers, directors, or trustees and none of its employees who will directly provide services under this Agreement are immediate family members of any member of the Owner’s Board of Education or of any principal or central office staff administrator employed by the Owner. For purposes of this provision, “immediate family” means spouse, parent, child, brother, sister, grandparent, or grandchild, and includes step, half, and in-law relationships. Should Contractor become aware of any family relationship covered by this provision or should such a family relationship arise at any time during the term of this Agreement, Contractor shall immediately disclose the family relationship in writing to the Superintendent. Unless formally waived by the Owner, the existence of a family relationship covered by this Agreement is grounds for immediate termination by Owner without further financial liability to Contractor.
- 4.24.15 Restricted Companies Lists. Contractor represents that as of the date of this Agreement, Contractor is not included on the Final Divestment List created by the North Carolina State Treasurer pursuant to N.C. Gen. Stat. § 147-86.58. Contractor also represents that as of the date of this Agreement, Contractor is not included on the list of restricted companies

determined to be engaged in a boycott of Israel created by the North Carolina State Treasurer pursuant to N.C. Gen. Stat. § 147-86.81.

ARTICLE 5

SUBCONTRACTORS

5.1 DEFINITION

5.1.1 A Subcontractor is a person or entity who has a direct contract with the Contractor to perform any of the Work at the site. The term Subcontractor may be referred to throughout the Contract Documents as if singular in number and masculine in gender and means a Subcontractor or his authorized representative. The term Subcontractor does not include any Separate Contractor or his subcontractors.

5.1.2 A Sub-subcontractor is a person or entity who has a direct or indirect contract with a Subcontractor to perform any of the Work at the site or who contracts to perform or supply any of the Work under the scope of a Subcontractor's subcontract. The term Sub-subcontractor may be referred to throughout the Contract Documents as if singular in number and masculine in gender and means a Sub-subcontractor or an authorized representative thereof.

5.1.3 Nothing contained in the Contract Documents is intended to, nor shall it create, any contractual relationship between the Owner, the Design Consultant, or any of their agents, consultants, employees, independent contractors, or representatives and any Subcontractor, Sub-subcontractor, Supplier or Vendor of the Contractor, except the relationship between Owner and Contractor, but the Owner shall be entitled to performance of all obligations intended for his benefit, and to enforcement thereof.

5.1.4 The Owner and Design Consultant will not deal directly with any Subcontractor, Sub-subcontractor or Material Supplier. Communication will be made only through the Contractor. Subcontractor, Sub-subcontractors or Material Suppliers shall route requests for information or clarification through the Contractor to the Design Consultant.

5.2 AWARD OF SUBCONTRACTS AND OTHER CONTRACTS FOR PORTIONS OF THE WORK

5.2.1 The Contractor, in compliance with the requirements of the Contract Documents and within ten (10) days after the Notice to Proceed, shall furnish in writing to the Owner the names of the persons or entities (including those who are to furnish materials or equipment fabricated to a special design) proposed for each of the principal portions of the Work. The Owner will promptly reply to the Contractor in writing stating whether or not the Owner, after due investigation, has reasonable objection to any such proposed person or entity. Failure of the Owner to reply within a reasonable time shall constitute notice of no reasonable objection. The Contractor understands and agrees that no contractual agreement exists for any part of the Work under this Contract between the Owner and any of the Contractor's Subcontractors or Sub-subcontractors. Further, the Contractor understands and agrees that he alone is responsible to the Owner for the Work under this Contract and that any review of Subcontractors or Sub-subcontractors by the Owner will not in any way make the Owner responsible to any Subcontractor, nor responsible for the actions or failures of any Subcontractor or Sub-subcontractor.

- 5.2.1.1 The Contractor shall identify in the list of names of the Subcontractors proposed, those Subcontractors that are Historically Underutilized Businesses (HUB's) and indicate the portion of the Work that each Subcontractor will perform.
- 5.2.2 The Contractor shall not contract with any such proposed person or entity to whom the Owner has made reasonable objection under the provisions of Paragraph 5.2.1. The Contractor shall not be required to contract with anyone to whom he has a reasonable objection.
- 5.2.3 If the Owner has reasonable objection to any proposed person or entity under Paragraph 5.2.1, the Contractor shall name a substitute to whom the Owner has no reasonable objection. The Contract Sum shall be increased or decreased by the difference in cost occasioned by such substitution and an appropriate Change Order shall be issued, subject to an audit of said difference by the Owner; provided, however, that no increase in the Contract Sum shall be allowed for any such substitution unless the Contractor has acted promptly and responsively in submitting names as required by Paragraph 5.2.1 and the original proposed Subcontractor was: (i) able to carry out his work under his proposed subcontract, (ii) able to comply with all applicable laws, (iii) was an ongoing business in the field of his proposed subcontract, and (iv) had a labor force, capital and a means of supply compatible with the scope of his proposed subcontract.
- 5.2.4 If the Owner requires a change of any proposed Subcontractor or person or organization previously accepted by him on the Project, the Contract Sum shall be increased or decreased by the difference in cost occasioned by such change and an appropriate Change Order shall be issued, subject to an audit by Owner.
- 5.2.5 The Contractor shall notify the Owner and the Design Consultant of any substitution for any Subcontractor identified in accordance with Subparagraph 5.2.1.1. The Contractor shall make no substitution for any Subcontractor, person or entity previously selected if the Owner or the Design Consultant makes reasonable objection to such substitution. Also, Contractor may make no substitution of Subcontractors in violation of applicable law.
- 5.2.6 If during the duration of the Project, the Contractor effects a substitution for any Subcontractor per Paragraph 5.2.5, or if additional subcontract opportunities become available, the Contractor shall make a good faith effort to utilize Historically Underutilized Businesses (HUB's).

5.3 SUBCONTRACTUAL RELATIONS

- 5.3.1 By an appropriate written agreement, the Contractor shall require each Subcontractor, to the extent of the Work to be performed by the Subcontractor, to be bound to the Contractor by the terms of the Contract Documents, and to assume toward the Contractor all the obligations and responsibilities which the Contractor, by these Contract Documents, assumes toward the Owner. Said agreement shall preserve and protect the rights of the Owner under the Contract Documents with respect to the Work to be performed by the Subcontractor so that the subcontracting thereof will not prejudice such rights, and shall allow to the Subcontractor, unless specifically provided otherwise in the agreement between the Contractor and Subcontractor, the benefit of all rights, remedies and redress against the Contractor that the Contractor, by these Contract Documents, has against the Owner. Where appropriate, the Contractor shall require each Subcontractor to enter into similar agreements with his Sub-subcontractors. The Contractor shall make available to each proposed Subcontractor, prior to the execution of the subcontract, copies of the Contract Documents to which the Subcontractor will be bound by this Section 5.3, and identify to the Subcontractor any terms and conditions of the proposed Subcontract which may be at variance

with the Contract Documents. Each Subcontractor shall similarly make copies of such Contract Documents available to his Sub-subcontractors.

5.3.2 The provisions herein regarding Subcontractor approvals shall in no way affect the liability of the Contractor to the Owner regarding performance of all obligations by or payment of Subcontractors. Approval to subcontract with any given Subcontractor shall not to any degree relieve the Contractor of his obligation to perform or have performed to the full satisfaction of the Owner the Work required by this Contract.

5.3.3 The Contractor shall submit Notice to the Owner of any Claims by Subcontractors for which the Owner is believed to be responsible, in strict conformance with the same time requirements and other procedures established for the submission of the Contractor's Claims to the Owner.

5.4 QUALIFICATION SUBMITTALS

5.4.1 Specific qualification submittals may be required of Subcontractors, installers and suppliers for certain critical items of the Work. Required qualification submittals are set forth in detail in the Specifications and shall be collected and submitted by the Contractor for review and approval by the Design Consultant. All information required of a single Subcontractor, installer or supplier shall be contained in a single, complete submittal. The Contractor shall submit the required qualification information within ten (10) days after receipt of the Design Consultant's request.

5.4.2 The Owner and Design Consultant shall reject any proposed Subcontractor, installer or supplier, or any qualification submittals related thereto, for the following reasons:

- .1 The Contractor's failure to submit requested information within the specified time; or
- .2 The Contractor's failure to provide all of the requested information; or
- .3 The Contractor's submission of a Subcontractor, installer or supplier, or qualifications thereof, which are unacceptable in the judgment of the Owner or Design Consultant.

5.4.3 Should the Owner or Design Consultant have reasonable objection to any proposed Subcontractor, installer or supplier, the Contractor shall submit another person or firm who are reasonably acceptable to the Owner and Design Consultant.

5.5 PREPARATORY WORK

5.5.1 Before starting a portion of the Work, the Contractor and the responsible Subcontractor shall carefully examine all preparatory work that has been executed to receive his work. The Subcontractor shall check carefully, by whatever means are required, to ensure that his work and adjacent related work will finish to proper contours, planes and levels. He shall promptly notify the Contractor and the Design Consultant of any defects or imperfections in preparatory work, which will, in any way, affect satisfactory completion of his work. Absence of such notification will be construed as an acceptance of preparatory work and later Claims of defects therein will not be recognized.

5.5.2 Under no conditions shall a portion of the Work proceed prior to preparatory work having been completed, cured, dried, and otherwise made satisfactory to receive such related work. Responsibility for timely installation of all materials rests solely with the Contractor, who shall maintain coordination control at all times.

ARTICLE 6

WORK BY OWNER OR BY SEPARATE CONTRACTORS

6.1 OWNER'S RIGHT TO PERFORM WORK AND TO AWARD SEPARATE CONTRACTS

6.1.1 The Owner reserves the right to perform work related to the Project with his own forces, and to award separate contracts in connection with other portions of the Project or other work on the site under these or similar conditions of the Contract.

6.1.2 When separate contracts are awarded for different portions of the Project or other work on the site, the term Contractor in the Contract Documents in each case shall mean the Contractor who executes each separate Owner-Contractor Agreement.

6.2 MUTUAL RESPONSIBILITY

6.2.1 The Contractor shall afford Separate Contractors and the Owner reasonable opportunity for the introduction and storage of their materials and equipment and the execution of their work and shall properly connect and coordinate the Work with that of the Owner and other contractors to store his apparatus, materials, supplies and equipment in such orderly fashion at the site of the Work as will not unduly or unreasonably interfere with the progress of the Work or the work of any other contractors.

6.2.1.1 If the execution or result of any part of the Work depends upon any work of the Owner or of any Separate Contractor, the Contractor shall, prior to proceeding with the Work, inspect and promptly report to the Owner in writing any apparent discrepancies or defects in such work of the Owner or of any Separate Contractor that render it unsuitable for such proper execution or result of any part of the Work.

6.2.1.2 Failure of the Contractor to so inspect and report shall constitute an acceptance of the Owner's or Separate Contractor's work as fit and proper to receive the Work, except as to defects which may develop in the Owner's or Separate Contractor's work after completion of the Work and which the Contractor could not have discovered by its inspection prior to completion of the Work.

6.2.2 Should the Contractor cause damage to the Work or property of the Owner or of any Separate Contractor on the Project, or to other work on the site, or delay or interfere with the Owner's work on ongoing operations or facilities or adjacent facilities or said Separate Contractor's work, the Contractor shall be liable for the same; and, in the case of another contractor, the Contractor shall attempt to settle said Claim with such other contractor prior to such other contractor's institution of litigation or other proceedings against the other contractor.

6.2.2.1 Should a Separate Contractor be declared in default by the Owner, the Owner shall not be obligated to hire a contractor to perform the work of the Separate Contractor during the time the Separate Contractor's surety is remedying the default pursuant to Paragraph 3.4.2.

6.2.2.2 If such Separate Contractor sues the Owner or Design Consultant on account of any damage, delay or interference cause or alleged to have been caused by the Contractor, the Owner shall notify the Contractor, who shall defend the Owner and Design Consultant in such proceedings at the Contractor's expense. If any judgment or award is entered against the Owner or Design

Consultant in such proceedings, the Contractor shall satisfy the same and shall reimburse the Owner and Design Consultant for all damages, expenses, attorney's fees and other costs which the Owner or Design Consultant incurs as a result thereof.

6.2.3 Should a Separate Contractor cause damage to the Work or to the property of the Contractor or cause delay or interference with the Contractor's performance of the Work, the Contractor shall present directly to said Separate Contractor any Claims it may have as a result of such damage, delay or interference (with an information copied to the Owner) and shall attempt to settle its Claim against said Separate Contractor prior to the institution of litigation or other proceedings against said Separate Contractor.

6.2.3.1 In no event shall the Contractor seek to recover from the Owner or the Design Consultant, and the Contractor hereby waives any Claims against the Owner and Design Consultant relating to any costs, expenses (including, but not limited to, attorney's fees) or damages or other losses incurred by the Contractor as a result of any damage to the Work or property of the Contractor or any delay or interference caused by any Separate Contractor.

6.2.4 Whenever Contractor receives items from another contractor or from Owner for storage, erection or installation, the Contractor receiving such items shall give receipt for items delivered, and thereafter will be held responsible for care, storage and any necessary replacing of item or items received.

6.2.5 When certain items of equipment and other work are indicated as "NIC" (not in contract), or to be furnished and installed under other contracts, any requirements set forth in the Contract Documents for preparation of openings, provision of backing, etc., for receipt of such "NIC" work will be furnished upon written request of the Contractor who shall properly form and otherwise prepare his work in a satisfactory manner to receive such "NIC" work.

6.3 OWNER'S RIGHT TO PERFORM DISPUTED WORK

6.3.1 If a dispute arises between the Contractor and Separate Contractors as to their responsibility for cleaning up as required by Section 4.18 or for accomplishing coordination or doing required cutting, filling, excavating or patching as required by Section 4.17, the Owner may carry out such work and charge the cost thereof to the responsible party as the Owner shall determine to be just.

6.4 COORDINATION OF THE WORK

6.4.1 By entering into this Contract, Contractor acknowledges that there may be other contractors on the site whose work will be coordinated with that of his own. Contractor expresses, warrants and guarantees that he will cooperate with other contractors and will do nothing to delay, hinder or interfere with the work of other Separate Contractors, the Owner or Design Consultant. Contractor also expressly agrees that, in the event his work is hindered, delayed, interfered with or otherwise affected by a Separate Contractor, his sole remedy will be a direct action against the Separate Contractor as described in this Article 6. Contractor will have no remedy, and hereby expressly waives any remedy, against the Owner and/or the Design Consultant on account of delay, hindrance, interference or other event caused by a Separate Contractor.

ARTICLE 7

MISCELLANEOUS PROVISIONS

7.1 GOVERNING LAW

7.1.1 This Contract shall be governed by the laws of the State of North Carolina.

7.1.2 Each and every provision of law and clause required by law to be inserted in this Contract shall be deemed to be inserted herein and the Contract shall be read and enforced as though it were included herein. If through mistake or otherwise, any such provision is not inserted or is not correctly or fully inserted, then upon the application of either party, the Contract shall forthwith be physically amended to make such insertion.

7.2 SUCCESSORS AND ASSIGNS

7.2.1 The Owner and the Contractor each binds himself, his partners, successors, assigns and legal representatives to the other party hereto and to the partners, successors, assigns and legal representatives of such other party in respect to all covenants, agreements and obligations contained in the Contract Documents. The Contractor shall not assign the Contract or sublet it as a whole without the written consent of the Owner, nor shall the Contractor assign any moneys due or to become due to him hereunder, without the previous written consent of the Owner and the Contractor's Surety.

7.3 CLAIMS AND DAMAGES

7.3.1 Should the Contractor, Subcontractor or any Sub-subcontractor suffer injury or damage to person or property because of any act or omission of the Owner or Design Consultant, or of any of their employees, agents or others for whose acts either is legally liable, the Claim on behalf of the Contractor its Subcontractors or Sub-subcontractors shall be made by giving Notice to the Owner, as provided in Article 15 ; otherwise, the Contractor, Subcontractors and Sub-subcontractors shall have waived any and all rights he may have against the Owner or the Design Consultant, or their employees, representatives and agents. The Contractor shall indemnify, defend and hold the Owner harmless from any Claim by a Subcontractor that is waived because it is not filed in strict conformance with this Paragraph or any other provision of the Contract regarding Claims.

7.4 PERFORMANCE BOND AND LABOR AND MATERIAL PAYMENT BOND

7.4.1 The Contractor shall furnish bonds covering the faithful performance of the Contract and the payment of all obligations arising thereunder in a form and with a Surety satisfactory to the Owner.

7.4.2 The Contractor is required to furnish in duplicate a Performance Bond and a Labor and Material Payment Bond, each in the amount of one hundred percent (100%) of the Contract Sum, written by a surety company licensed to do business in North Carolina and with a minimum AM Best "A" rating or comparable rating from another service reasonably acceptable to Owner.

7.5 RIGHTS AND REMEDIES

7.5.1 The duties and obligations of the Contractor imposed by the Contract Documents and the rights

and remedies of the Owner available thereunder shall be in addition to and not a limitation of any duties, obligations, rights and remedies otherwise imposed or available by law.

7.5.2 Except as may be specifically agreed in writing, the failure of the Owner or the Design Consultant to insist in any one or more instances upon the strict performance of any one or more of the provisions of the Contract, or to exercise any right herein contained or provided by law, shall not be construed as a waiver or relinquishment of the performance of such provisions or right(s) or of the right to subsequently demand such strict performance or exercise such right(s), and the rights shall continue unchanged and remain in full force and effect.

7.5.3 The Contractor agrees that he can be adequately compensated by money damages for any breach of the Contract which may be committed by the Owner and hereby agrees that no default, act, or omission of the Owner or the Design Consultant, except for failure to make progress payments as required by the Contract Documents, shall constitute a material breach of the Contract entitling the Contractor to cancel or rescind the provisions of the Contract or (unless the Owner shall so consent or direct in writing) to suspend or abandon performance of all or any part of the Work. The Contractor hereby waives any and all rights and remedies to which he might otherwise be or become entitled, save only his right to money damages.

7.6 TESTS AND INSPECTIONS

7.6.1 If the Contract Documents, laws, ordinances, rules, regulations or orders of any public authority having jurisdiction require any portion of the Work to be inspected, tested, or approved, the Contractor shall give the Owner and Design Consultant timely Notice of its readiness so the Design Consultant and the Owner may observe such inspection, testing or approval. Unless otherwise specifically provided in the Contract Documents, the Contractor shall bear all costs of such inspections, tests or approvals, except that Owner shall pay for "special inspections" as defined and required in Section 1704, the North Carolina State Building Code, or successor section. In the event that such "special inspections" reveal a failure of the Work to comply with the Contract Documents or applicable laws, ordinances, regulations or orders of public authorities having jurisdiction, Contractor shall reimburse the Owner for the costs of such "special inspections".

7.6.1.1 Unless otherwise stipulated in the Contract Documents, the Contractor shall pay for all utilities required for testing of installed equipment of all of his work and work of each Subcontractor. Boiler fuel other than gas shall be provided by Subcontractor furnishing boilers. Labor and supervision required for making such tests shall be provided at no additional cost to the Owner.

7.6.2 If the Design Consultant or the Owner determines that any portion of the Work requires additional inspection, testing, or approval which Paragraph 7.6.1 does not include, the Owner will instruct the Contractor to order such additional inspection, testing or approval, and the Contractor shall give Notice as provided in Paragraph 7.6.1. If such additional inspection or testing reveals a failure of any portion of the Work to comply (1) with the requirements of the Contract Documents, or (2) with respect to the performance of the Work, with laws, ordinances, rules, regulations, or orders of any public authority having jurisdiction, the Contractor shall bear all costs thereof, including compensation for the Design Consultant's and Owner's additional construction management expenses made necessary by such failure.

7.6.3 With regard to inspections and tests, the costs of which the Owner is responsible for paying, they will be made by a pre-qualified, independent testing agency selected by the Owner. The cost of the initial services of such agency will be paid by the Owner. When the initial tests indicate non-compliance with the Contract Documents, any subsequent testing occasioned by

non-compliance shall be performed by the same agency and the cost thereof shall be borne by the Contractor. Representatives of the testing agency shall have access to the Work at all times. The Contractor shall provide facilities for such access in order that the agency may properly perform its functions.

7.6.4 The independent testing agency, contracted by the Owner, shall prepare the test reports, logs, and certificates applicable to the specific inspections and tests and promptly deliver the specified number of copies to the designated parties. Certificates of inspection, testing or approval required by public authorities shall be secured by the Contractor and promptly delivered by him to the Owner, in adequate time to avoid delays in the Work or final payment therefore.

7.6.5 If the Design Consultant or the Owner is to observe the inspections, tests or approvals required by the Contract Documents, laws, ordinances, rules, regulations, or order of any public authority having jurisdiction or that are required to establish compliance with the Contract Documents, he will do so promptly and, where practicable, at the normal place of testing.

7.6.6 The Contractor shall pay for and have sole responsibility for inspections or testing performed exclusively for his own convenience.

7.7 UNENFORCEABILITY OF ANY PROVISION

7.7.1 If any provision of this Contract is held as a matter of law to be unenforceable or unconscionable, the remainder of the Contract shall be enforceable without such provision.

7.8 ATTORNEYS' FEES AND OTHER EXPENSES

7.8.1 The Contractor hereby agrees that he will not submit, assert, litigate or otherwise pursue any frivolous or unsubstantiated Claims or Claims he has specifically waived under the terms of the Contract Documents. In the event that the Contractor's or its Subcontractor's or Sub-subcontractor's Claims, or any separate item of a Claim, is without substantial justification, the Contractor shall reimburse the Owner or Design Consultant for all costs and expenses associated with defending such Claim or separate item, including but not limited to, attorneys' fees, audit costs, accountants' fees, expert witness' fees, additional Design Consultant expenses, additional construction management expenses, or services and any other consultant costs.

7.8.2 If the Contractor breaches any obligation under the Contract Documents, the Contractor shall reimburse the Owner and Design Consultant for all costs and expenses incurred by the Owner relating to such breach, including but not limited to attorneys' fees, audit costs, accountants' fees, expert witness' fees, additional Design Consultant expenses, additional construction management expenses, and any other consultant costs.

7.8.3 If the Owner or Design Consultant substantially prevails in a Claim brought against the Contractor, or in defending a Claim brought by the Contractor, including but not limited to, Claims for fraud or misrepresentation, overpayment, defective work, delay damages, and recovery of termination expenses, the Contractor shall reimburse the Owner and/or Design Consultant for all costs and expenses incurred by them relating to such Claim, including but not limited to attorneys' fees, audit costs, accountants' fees, expert witness' fees, additional Design Consultant expenses, additional construction management expenses, and any other consultant costs.

ARTICLE 8

TIME

8.1 DEFINITIONS

- 8.1.1 Unless otherwise provided, the Contract Time is the period of time allotted in the Contract Documents for Final Completion of the Work as defined in Paragraph 8.1.4, including authorized adjustments thereto. The Contractor shall achieve Final Completion within the Contract Time.
- 8.1.2 The date of commencement of the Work is the date established in the Notice to Proceed. If there is no Notice to Proceed, it shall be the date of the Owner-Contractor Agreement or such other date as may be established therein. The Contractor shall not commence work or store materials or equipment on site until written Notice to Proceed is issued or until the Contractor otherwise receives the Owner's written consent.
- 8.1.3 The date of Substantial Completion of the Work or designated portion thereof is the date certified by the Design Consultant and the Owner when the Work or a designated portion thereof is sufficiently complete, in accordance with the Contract Documents, so the Owner can fully and legally occupy and utilize the Work or designated portion thereof for the use for which it is intended, with all of the parts and systems operable as required by the Contract Documents, including a preliminary test and balance report for the mechanical system. Only incidental corrective work and any final cleaning beyond that needed for the Owner's full use may remain for Final Completion. The Contractor acknowledges and agrees that the intercom, telephone, data security, building automation system (including functional graphics at the site), MATV, and other educational operational systems are required for the Owner's use of the building for its intended purpose. The Contractor shall provide operation and maintenance manuals to the Owner as required by the Contract Documents prior to Substantial Completion and shall provide the required training on the operation of the equipment and systems within two weeks of Substantial Completion. The Contractor shall achieve Substantial Completion by the date specified in the Supplemental Conditions including authorized adjustments thereto. The Owner's occupancy of incomplete work shall not alter the Contractor's responsibilities pursuant to this paragraph. Only incidental corrective work and any final cleaning beyond that needed for the Owner's full use may remain for Final Completion. The issuance of a temporary or final certificate of occupancy shall not, in itself, constitute Substantial Completion.
- 8.1.4 Final Completion of the Work occurs on the date certified by the Design Consultant and the Owner when the Work is totally complete, to include punch list work, in accordance with the Contract Documents and the Owner may fully occupy and utilize the Work for the use for which it is intended. The issuance of a temporary or final certificate of occupancy shall not, in itself, constitute Final Completion.
- 8.1.5 The term Day as used in the Contract Documents shall mean calendar day unless otherwise specifically designated. All dates shall mean midnight of the indicated day unless otherwise stipulated.
- 8.1.6 Completion Dates shall mean the dates set forth in the Supplemental Conditions for Substantial Completion and Final Completion.

8.2 PROGRESS AND COMPLETION

- 8.2.1 All time limits stated in the Contract Documents are of the essence of the Contract with respect to the Contractor's performance.
- 8.2.2 The Contractor shall begin the Work on the date of commencement as defined in Paragraph 8.1.2. He shall carry the Work forward expeditiously with adequate forces and shall achieve Substantial Completion and Final Completion within the time frames stated in the Contract Documents.
- 8.2.3 Attention is directed to the fact that the Work is urgently needed by the Owner; for this reason, it shall be agreed that the Contractor and its Subcontractors will achieve Substantial Completion of the Work under the Contract within the time established under Paragraph 8.2.4 of the Supplemental Conditions after award of Contract, or Notice to Proceed, and that he will achieve Final Completion of the Work in all its details for final acceptance within the time established under Paragraph 8.2.4 of the Supplemental Conditions.
- 8.3 DELAYS AND EXTENSIONS OF TIME
- 8.3.1 The time during which the Contractor or any of the Subcontractors is delayed in the performance of the Work by the issuance of any required permits, acts of god, excessive inclement weather, fires, floods, epidemics, quarantine restrictions, strikes, riots, civil commotions or freight embargoes, or other conditions beyond the Contractor's or the Subcontractors' control and which the Contractor or the Subcontractors could not reasonably have foreseen and provided against, except for delays caused solely by the Owner, Design Consultant or their consultants, shall be added to the time for completion of the Work stated in the Contract. Neither the Owner nor the Design Consultant shall be obligated or liable to the Contractor or the Subcontractors for indirect or direct damages, costs or expenses of any nature which the Contractor, the Subcontractors, or any other person may incur as a result of any of the delays, interferences, changes in sequence in the Work included in this Section 8.3.1. The Contractor hereby expressly waives any Claims against the Owner and the Design Consultant on account of any indirect or direct damages, lost profits, costs or expenses of any nature which the Contractor, the Subcontractors or any other person may incur as a result of any delays, interferences, changes in sequence or the like, and it is understood and agreed that the Contractor's sole and exclusive remedy in any such events shall be an extension of the Contract time in accordance with the Contract Documents.
- 8.3.2 In the event Project delays arise from or out of any act or omission of the Owner, Design Consultant or their consultants, the time during which the Project is delayed shall be added to the Contract and the Contractor may be reimbursed for its direct Project damages, excluding general overhead expenses and indirect costs, if the Contractor strictly complies with this Article 8.3. Notwithstanding the previous sentence, if the Contractor or Subcontractor in any way shares in responsibility for the delay, neither the Owner nor the Design Consultant shall be obligated or liable to the Contractor or the Subcontractors for indirect or direct damages, costs or expenses of any nature which the Contractor, the Subcontractors, or any other person may incur as a result of any of the delays, interferences, changes in sequence of the Work, and the Contractor's sole remedy, if any, shall be an extension of the Contract time.
- 8.3.3 In the event Project delays arise solely from or out of any act or omission of the Contractor, Subcontractors or their agents, the Contractor shall not be entitled to extension of the Contract time and shall be subject to the payment of Liquidated Damages as provided in this Contract.
- 8.3.4 The Contract time shall be adjusted only for changes pursuant to section 12.1, suspension of the Work pursuant to paragraph 3.3.2 or paragraph 3.3.3, and excusable delays pursuant to

paragraph 8.3.4. In the event the Contractor requests an extension of the Contract time or files a Claim related to any form of delay, it shall furnish such justification and supporting evidence as the Owner may deem necessary for a determination of whether or not the Contractor is entitled to an extension of time under the provisions of the Contract, and shall further conform to all of the requirements of the specifications and the Contract regarding construction schedules and reports. The burden of proof to substantiate a Claim shall rest with the Contractor, including evidence that the cause was beyond its control. The Owner shall base its findings of fact and decision on such justification and supporting evidence, including a finding that the alleged delay impacted the Project's critical path, and shall advise the Contractor in writing thereof. If the Owner finds that the Contractor is entitled to any extension of the Contract time, the Owner's determination of the total number of days of extension shall be based upon the currently approved progress schedule and on all data relevant to the extension. Such data will be incorporated into the schedule in the form of a revision thereto, accomplished in a timely manner. The Contractor acknowledges and agrees that actual delays (due to said changes, suspension of Work or excusable delays) in activities which, according to the schedule, do not affect the Contract time, do not have any effect upon the Contract time and therefore will not be the basis for a change therein. The Contractor acknowledges and agrees that time extensions will be granted only to the extent that excusable delays exceed the available float in the critical path activities in the Contractor's currently approved schedule.

8.3.4.1 Extensions in the Contract time by Change Orders are subject to extension-in-time audit by the Owner as follows:

8.3.4.1.1 The Contractor agrees that, even though the Owner, Contractor and Design Consultant have previously signed a Change Order containing an extension-in-time resulting from a change in or addition to the Work that said extension in the Contract time may be adjusted by an audit after the fact by the Owner. If such an audit is to be made, the Owner must undertake the audit and make a ruling within thirty (30) days after the completion of the Work under the Change Order.

8.3.4.1.2 The Contractor agrees that any extension of the Contract time to which it is entitled arising out of a Change Order undertaken on a force accounting (labor and materials) basis, shall be determined by an extension-in-time audit by the Owner after the Work of the Change Order is completed. Such rulings shall be made by the Owner within thirty (30) days after a request for same is made by the Contractor or Design Consultant, except said thirty (30) days will not start until the Work under the Change Order is completed.

8.3.4.1.3 Should a time extension be granted for Substantial Completion the date for Final Completion shall be appropriately adjusted unless specifically stated otherwise.

8.3.4.2 Subject to other provisions of the Contract, the Contractor may be entitled to an extension of the Contract time (but no increase in the Contract sum) for delays arising from unforeseeable causes beyond the control and without the fault or negligence of the Contractor, the Subcontractors or suppliers as follows:

8.3.4.2.1 Labor disputes and strikes (including strikes affecting transportation), that do, in fact, directly delay the progress of the Work on the critical path; however, an extension of Contract time on account of an individual labor strike shall not exceed the number of days of said strike;

8.3.4.2.2 Acts of nature: tornado, fire, hurricane, blizzard, earthquake, or flood that damage Work in place or stored materials or adversely impact the schedule's critical path;

8.3.4.2.3 Excessive inclement weather; however, the Contract time will not be extended due to reasonably anticipated inclement weather or for delays in the aftermath of inclement weather, reasonably anticipated or excessive. The time for performance of this Contract, as stated in the Contract Documents, includes an allowance for calendar days which may not be available for construction out-of-doors; for the purposes of this Contract, the Contractor agrees that the number of calendar days per month based on a five-year average shall be considered reasonably anticipated inclement weather and planned for in the construction schedule per the Contract. Unless the Contractor can substantiate to the satisfaction of the Owner that there was greater than the reasonably anticipated inclement weather considering the time from the notice-to-proceed until the building is enclosed using data from the national weather service station identified in the Supplemental Conditions, or a weather station acceptable to the Owner and that such alleged greater than reasonably anticipated inclement weather actually delayed the Work or portions thereof which had an effect upon the Contract time, the Contractor shall not be entitled to an extension of time.

Also the Contractor agrees that the calculation of the number of excessive inclement weather days shall be the number of days in excess of the five-year average for each month, in which precipitation exceeded one tenth (.10) inch, or in which the highest temperature was 32 degrees F or less as recorded at the approved weather station. Rain days from hurricanes and tropical storms not causing damage in the county in which the project is located shall be deemed inclement weather days.

If the total accumulated number of calendar days lost to excessive inclement weather, from the notice-to-proceed until the building is enclosed, exceeds the total accumulated number to be reasonably anticipated for the same period from the table above, time for completion will be extended by the number of calendar days needed to include the excess number of calendar days lost. No extension of time will be made for days due to excessive inclement weather occurring after the building is enclosed. For the purpose of this Contract, the term "enclosed" is defined to mean when the building is sufficiently roofed and sealed, either temporarily or permanently, to permit the structure to be heated and the plastering and dry-wall trades to work. The Design Consultant shall determine when the structure is "enclosed". Upon the request of either party, the Design Consultant shall issue a letter certifying to the Owner, with a copy to the Contractor, stating the date the building became enclosed. No change in Contract sum will be authorized because of adjustment of Contract time due to excessive inclement weather; and

8.3.4.2.4 Delays in the issuance of a permit required for construction of the Project, acts of the public enemy, acts of the State, Federal or local government in its sovereign capacity, and acts of another Contractor in the performance of a Contract with the Owner relating to the Project.

8.3.5 If the Contractor shall neglect, fail or refuse to complete the Work within the time herein specified, or any proper extension thereof granted by the Owner, then the Contractor does hereby agree, as a part consideration for the awarding of this Contract, to pay the Owner the amount specified in the Contract, not as a penalty but as Liquidated Damages for such breach of Contract as hereinafter set forth, for each and every calendar day that the Contractor shall be in default after the time stipulated in the Contract for completing the Work. The said amount is fixed and agreed upon by and between the Contractor and the Owner because of the impracticability and extreme difficulty of fixing and ascertaining the actual damages the Owner would in such event sustain, and said amount is agreed to be the amount of damages which the Owner would sustain and said amount shall be retained from time to time by the Owner from current periodical estimates.

- 8.3.6 The Contractor and the Subcontractors shall not be entitled to and hereby expressly waive any extension of time resulting from any condition or cause unless said Claim for extensions of time is made in writing to the Owner within ten (10) days of the first instance of delay for all delays, except excessive inclement weather which shall be made in writing to the Owner within forty-five (45) days after the date the structure is enclosed. Circumstances and activities leading to such Claim shall be indicated or referenced in a daily field inspection report for the day(s) affected. In every such written Claim, the Contractor shall provide the following information:
- 8.3.6.1 Nature of the delay;
- 8.3.6.2 Date (or anticipated date) of commencement of delay;
- 8.3.6.3 Activities on the progress schedule affected by the delay, and/or new activities created by the delay and their relationship with existing activities;
- 8.3.6.4 Identification of person(s) or organization(s) or event(s) responsible for the delay;
- 8.3.6.5 Anticipated extent of the delay; and
- 8.3.6.6 Recommended action to avoid or minimize the delay.
- 8.3.7 If no schedule or agreement is made stating the dates upon which written interpretations as set forth in Section 2.2 shall be furnished, then no Claim for delay shall be allowed on account of failure to furnish such interpretations until twenty (20) days after request is made for them, and not then unless such Claim is reasonable.
- 8.3.8 No Claim by the Contractor for an extension of time for delays will be considered unless made in strict compliance with the requirements of this Article. All Claims not filed in accordance with this paragraph shall be waived by the Contractor.
- 8.4 RESPONSIBILITY FOR COMPLETION
- 8.4.1 The Contractor shall be responsible for completion in accordance with Paragraph 4.12.1.
- 8.4.2 The Owner may require the Contractor to submit a recovery schedule demonstrating his program and proposed plan to make up the lag in scheduled progress and to ensure completion of the Work within the Contract Time if the Project is behind schedule by four (4) or more days. If the Owner finds the proposed plan not acceptable, he may require the Contractor to submit a new plan. If the actions taken by the Contractor or the second plan proposed are not satisfactory, the Owner may require the Contractor to take any of the actions set forth in Paragraph 4.12.2 without additional cost to the Owner, to make up the lag in scheduled progress.
- 8.4.3 Failure of the Contractor to substantially comply with the requirements of this Section 8.4 may be considered grounds for a determination by the Owner, pursuant to Section 14.3, that the Contractor is failing to prosecute the Work with sufficient diligence to ensure its completion within the Contract Time.
- 8.5 LIQUIDATED DAMAGES FOR DELAY
- 8.5.1 Owner and Contractor agree that the damages incurred by the Owner due to the Contractor's failure to achieve Substantial Completion by the date specified in the Supplemental Conditions for Substantial Completion, including any extensions thereof, shall be in the amounts set forth

in the Supplemental Conditions, for each consecutive day beyond the date of Substantial Completion that Contractor achieves Substantial Completion, and that the damages incurred by the Owner due to the Contractor's failure to achieve Final Completion by the date specified in the Supplemental Conditions for Final Completion, including any extensions thereof, shall be in the amount set forth in the Supplemental Conditions for each consecutive day beyond the date of Final Completion that Contractor achieves Final Completion. The Liquidated Damages are a reasonable estimate by Contractor and Owner of the damages to be suffered by Owner and are not to be construed as a penalty, it being recognized by the Owner and the Contractor that the injury to the Owner which could result from a failure of the Contractor to complete on schedule is uncertain and cannot be computed exactly or that it would be unreasonably expensive for Owner to calculate its damages exactly.

- 8.5.2 The amount specified for Substantial Completion is the minimum measure of damages the Owner will sustain due to delay in the completion of the Work, which shall include, but not be limited to the loss of use of the facilities, the relocation of students and services, the cost of the Owner's time and resources, damage to the Owner's reputation, and storage of furniture and other materials. The amount specified for Final Completion is a reasonable and proper measure of the damages the Owner will sustain due to the delay in the completion of remedial work. This amount includes the disruption to the school and the learning environment, the cost of the Owners time and resources, damage to the Owner's reputation, and the inability to fully use the facilities. The inability of the Owner to quantify actual damages shall not prevent the recovery of Liquidated Damages.
- 8.5.3 Notwithstanding any other provisions of these General Conditions, if there is concurrent delay in the completion of the Work, the Contractor shall be liable for Liquidated Damages as specified in the General Conditions and Supplemental Conditions during such period of concurrent delay. For the purpose of this Paragraph, concurrent delay means (a) a delay event caused in part by the Owner or its agent and in part by the Contractor or its agents, Subcontractors or Sub-subcontractors, or (b) one or more delay event caused solely by the Owner, its agents, or the Design Consultant, and one or more delay event caused in part by the Contractor, its agents, Subcontractors or Sub-subcontractors, each of which would have resulted in a delay without the other and which delays run concurrently, or at the same time. In the event that the foregoing provision making the Contractor liable for Liquidated Damages during a period of concurrent delay is found to be unenforceable, then the parties agree that in the event of a concurrent delay, the extent of the delay will be apportioned between the Owner and the Contractor, and the Contractor will be responsible for Liquidated Damages as set forth in the General Conditions and Supplemental Conditions for those portions of the delay which are apportioned to the Contractor, its agent, Subcontractors, Sub-subcontractors, or Material Suppliers.
- 8.5.4 The provisions for Liquidated Damages do not bar or limit Owner's other rights and remedies against Contractor, for damages other than for failure to achieve the Substantial Completion date or the Final Completion date as required. The amount of Liquidated Damages set forth in Section 8.5 shall not include additional legal or design professional costs that may result from the Contractor's default. If such legal or design professional costs are incurred by the Owner, the Contractor shall be liable to the Owner for those costs in addition to the Liquidated Damages amount set forth in Section 8.5.
- 8.5.5 The Liquidated Damages assessed for failure to meet Substantial Completion by the specified date and the Liquidated Damages assessed for failure to meet Final Completion by the specified date shall be assessed cumulatively.

ARTICLE 9

PAYMENTS AND COMPLETION

9.1 CONTRACT SUM

9.1.1 The Contract Sum is stated in the Owner-Contractor Agreement and, including authorized adjustments thereto, is the total amount payable by the Owner to the Contractor for the performance of the Work under the Contract Documents.

9.2 SCHEDULE OF VALUES

9.2.1 Before the first Application for Payment, the Contractor shall submit to the Owner a schedule of values allocated to the various portions of the Work and supported by such data to substantiate its accuracy as the Owner may require. This schedule, unless objected to by the Owner, shall be used as a basis for the Contractor's Applications for Payment and only for this purpose. If approved by the Owner, the Contractor may include in his schedule of values a line item for mobilization which shall include a reasonable amount of mobilization for the Contractor and his Subcontractors. The Contractor shall not front-end load his schedule of values.

9.3 APPLICATIONS FOR PAYMENT

9.3.1 Prior to the date for each progress payment established in the Owner-Contractor Agreement, the Contractor shall submit to the Design Consultant an itemized Application for Payment, notarized if required, supported by such data substantiating the Contractor's right to payment as the Design Consultant and the Owner may require, including but not limited to the Contractor's certification that all work for which payment is requested has been completed in full in accordance with the Contract Documents, and reflecting retainage, if any, as provided elsewhere in the Contract Documents. If requested by the Owner, the Contractor shall also certify that he has paid all due and payable amounts for which previous Applications for Payment were issued and payments received from the Owner, by providing waivers of liens for said payments.

9.3.1.1 The Contractor shall submit with the Application for Payment a list of those Historically Underutilized Businesses (HUB's) Subcontractors whose work is included in the application and the amount due each. In addition, the Historically Underutilized Business (HUB) must itself perform satisfactory work or services or provide supplies under the Contract and not act as a mere conduit.

9.3.2 The Owner will withhold retainage from Contractor on all Applications for Payment to the maximum extent and in the maximum amount allowed by law (currently codified at N.C.G.S. 143-134.1) and in accordance with that statute or applicable successor statute. In the event that N.C.G.S 143-134.1 or applicable successor statute are not in effect or do not apply at the time the Contract is executed, Owner will retain five percent (5%) of the amount of each Application for Payment from the Contractor as retainage, until Contractor achieves Final Completion, whether or not the Owner has occupied any or all of the Project before such time. However, if the Owner, at any time after fifty percent (50%) of the Work has been completed, finds that satisfactory progress is being made, he may authorize payment to the Contractor in full of each Progress Payment for work performed beyond the fifty percent (50%) stage of completion. If a reduction in retainage has been made, the Owner may increase the retainage back to original percentage at any time if the Owner concludes that the Contractor is not progressing with the Work in a timely or satisfactory manner.

- 9.3.3 Payments may be made by the Owner, at its sole discretion, on account of materials or equipment not incorporated in the work but delivered and suitably stored at the site or in a bonded warehouse by the Contactor. Payments for materials or equipment stored shall only be considered upon submission by the Contractor of satisfactory evidence (for example, releases or paid invoices from the seller) that the Contractor has acquired title to such material, that it will be utilized on the work under this Contract and that it is satisfactorily stored, protected, and insured or that other procedures satisfactory to the Owner that will protect the Owner's interests have been taken. In the event the materials are stored in a bonded warehouse that is not located in the county of the project, the Contractor shall reimburse the travel cost and hourly billing expenses incurred by the Design Consultant for travel to view and assess whether the materials meet the requirements of the Contract Documents. Materials once paid for by the Owner become the property of the Owner and may not be removed from the work site or bonded warehouse, other than to be delivered from the warehouse to the site, without the Owner's written permission. Responsibility for such stored materials and equipment shall remain with the Contractor regardless of ownership.
- 9.3.3.1 Owner will not make payment to the Contractor on account of materials or equipment not incorporated in the Work but delivered and stored at the site if the Contractor, in his schedule of values, does not include line items for such delivered and stored materials or equipment.
- 9.3.3.2 It is specifically understood and agreed that an inspection and approval of the materials by the Owner, the Design Consultant or any agency retained by any of them shall not in any way subject the Owner to pay for the said materials or any portion thereof, even though incorporated in the Work, if said materials shall in fact turn out to be unfit to be used in the Work, nor shall such inspection be considered as any waiver of objection to the Work on account of the unsoundness or imperfection of the material used.
- 9.3.4 The Contractor warrants that title to all work, materials and equipment covered by an Application for Payment will pass to the Owner either by incorporation in the construction or upon the receipt of payment by the Contractor, whichever occurs first, free and clear of all liens, claims, security interests or encumbrances, hereinafter referred to in this Article 9 as "liens"; and that no work, materials or equipment covered by an Application for Payment will have been acquired by the Contractor, or by any other person performing work at the site or furnishing materials and equipment for the Project, subject to an agreement under which an interest therein or an encumbrance thereon is retained by the seller or otherwise imposed by the Contractor or such other person.
- 9.3.5 The Contractor shall submit with the Application for Payment a notarized Contractor's Sales Tax Report of N.C. State and County sales taxes paid during the payment period with respect to building materials, supplies, fixtures, and equipment that have become a part of, or annexed to, a building or structure erected, altered or repaired for the Owner. The Sales Tax Report shall include the vendor from whom the property was purchased, the dates and number of invoices covering the purchase, the total amount of the invoices of each vendor, the North Carolina State and County sales and use tax paid thereof, and the cost of the property withdrawn from the warehouse stock and North Carolina sales or use taxes paid thereof. Items that should not be included are: scaffolding, forms for concrete, fuel for operation of machinery and equipment, tools, equipment, equipment repair parts and equipment rentals.
- 9.3.6 Unless an interest rate is required by law, Owner shall not pay any interest on an amount owed to Contractor. No interest shall accrue on amounts Owner is authorized by law or by the Contract to withhold or backcharge to Contractor.

9.4 CERTIFICATION OF PAYMENT

- 9.4.1 The Design Consultant will, after receipt of the Contractor's Application for Payment either issue a Certification of Payment to the Owner, with a copy to the Contractor, for such amount as the Design Consultant determines is properly due, or notify the Contractor in writing of their reasons for withholding a Certification as provided in Paragraph 9.6.1.
- 9.4.2 The submission and approval of the progress schedule and monthly updates thereof as required by the Contract shall be an integral part and basic element of the application upon which progress payment shall be made. The Contractor shall be entitled to progress payments only as determined from the currently approved and updated schedule.
- 9.4.3 The signing of a Certification of Payment will constitute a representation by the Design Consultant to the Owner, based on their observations at the site pursuant to their agreements with the Owner, and the data comprising the Application for Payment, that the Work has progressed to the point indicated; that, to the best of their knowledge, information and belief, the quality of the Work is in accordance with the Contract Documents (subject to an evaluation of the Work for conformance with the Contract Documents upon Substantial Completion, to the results of any subsequent tests required by or performed under the Contract Documents, to minor deviations from the Contract Documents correctable prior to completion, and to any specific qualifications stated in their Certification); and that the Contractor is entitled to payment in the amount certified. However, by signing a Certification of Payment, the Design Consultant shall not thereby be deemed to represent that it has made exhaustive or continuous on-site inspections to check the quality or quantity of the Work or that it has reviewed the construction means, methods, techniques, sequences, or procedures, or that it has made any examination to ascertain how or for what purpose the Contractor has used the moneys previously paid on account of the Contract Sum.

9.5 PROGRESS PAYMENTS

- 9.5.1 After a Certification of Payment has been issued, the Owner shall make payment in the manner and within the time provided in the Contract Documents, unless Contractor is in breach of the Contract or otherwise owes the Owner, in which case Owner may withhold an appropriate amount.
- 9.5.2 The Contractor shall promptly pay each Subcontractor (including suppliers, laborers, and material-men) performing labor or furnishing material or equipment for the Work, upon receipt of payment from the Owner, out of the amount paid to the Contractor on account of such Subcontractor's work, the amount to which said Subcontractor is entitled, reflecting the percentage actually retained, if any, from payments to the Contractor on account of such Subcontractor's work. The Contractor shall, by an appropriate agreement with each Subcontractor, also require each Subcontractor to make payments to his Sub-subcontractors in similar manner. The Owner may at any time require proof of payment to a Subcontractor or Sub-subcontractor for work paid by the Owner. Notwithstanding any other provision of the General Conditions, no Contractor, Subcontractor, Sub-subcontractor or Material Supplier shall have any Claim against the Owner, by virtue of the Contract, under any theory, including breach of contract, or third party beneficiary. The Owner shall not be in privity of any contract with any Subcontractor, Sub-subcontractor or Material Supplier pertaining to the Work, the Project and these General Conditions. Also, neither the Contractor, or any Subcontractor or Sub-subcontractor shall have any right to assert a lien on Owner's real property or on any funds held by Owner.

- 9.5.3 The Owner may, on request and at his discretion, furnish to any Subcontractor, if practicable, information regarding the percentages of completion or the amounts applied for by the Contractor and the action taken thereon by the Design Consultant on account of work done by such Subcontractor.
- 9.5.4 Neither the Owner nor the Design Consultant shall have any obligation to pay or to see to the payment of any moneys to any Subcontractor except as may otherwise be required by law.
- 9.5.5 No Certification for a progress payment, nor any progress payment or final payment, nor any partial or entire use or occupancy of the Project by the Owner, shall constitute an acceptance of any Work not in accordance with the Contract Documents.
- 9.5.6 The Contractor agrees to keep the Work and the site of the Project free and clear of all liens related to labor and materials furnished in connection with the Work. Furthermore, pursuant to and in compliance with requirements of Paragraph 9.3.4, the Contractor waives any right he may have to file any type of lien in connection with the Work. Notwithstanding anything to the contrary contained in the Contract Documents, if any such lien is filed or there is evidence to believe that any lien may be filed at any time during the progress of the Work or within the duration of this Contract, the Owner may refuse to make any payment otherwise due the Contractor or may withhold from any payment due the Contractor a sum sufficient in the opinion of the Owner to pay all obligations and expenses necessary to satisfy such lien or the underlying claim represented by such lien. The Owner may withhold such payment unless or until the Contractor, within ten (10) days after demand thereof by the Owner, shall furnish satisfactory evidence that the indebtedness and any lien in respect thereof has been satisfied, discharged and released of record, or that the Contractor has legally caused such lien to be released of record pending the resolution of any dispute between the Contractor and the person or persons filing such lien. If the Contractor shall fail to furnish such satisfactory evidence within ten (10) days of the demand thereof, the Owner may discharge such indebtedness and deduct the amount thereof, together with any and all losses, costs, damages and attorney's fees suffered or incurred by the Owner from any sum payable to the Contractor under the Contract Documents, including but not limited to final payment and retained percentage. This Paragraph 9.5.6 shall be specifically included in all Subcontracts and purchase orders entered into by the Contractor. Notwithstanding any other provision of the Contract, nothing in the Contract shall affect the rights of Subcontractors, Sub-subcontractors, Material Suppliers and Vendors from enforcing any lien rights they have against parties other than the Owner.

9.6 PAYMENTS WITHHELD

- 9.6.1 The Design Consultant may decline to certify payment and may withhold their Certification of Payment in whole or in part, to the extent necessary to reasonably protect the Owner, if in the Design Consultant's opinion it is unable to make representations to the Owner as provided in Paragraph 9.4.3. If the Design Consultant is unable to make representations to the Owner as provided in Paragraph 9.4.3 and to certify payment in the amount of the Application for Payment, it will notify the Contractor as provided in Paragraph 9.4.1. If the Contractor and the Design Consultant cannot agree on a revised amount, the Design Consultant will promptly issue a Certification of Payment for the amount for which it is able to make such representations to the Owner. The Design Consultant may also decline to certify payment because of subsequently discovered evidence or subsequent observations that may nullify the whole or any part of any Certification of Payment previously issued to such extent as may be necessary in its opinion to protect the Owner from loss, because of:

- .1 Defective Work not remedied,
- .2 Third party claims filed, whether in court, in arbitration or otherwise, or reasonable evidence indicating probable filing of such claims,
- .3 Failure of the Contractor to make payments properly to Subcontractors or for labor, materials or equipment,
- .4 Reasonable evidence that the Work cannot be completed for the unpaid balance of the Contract Sum,
- .5 Damage to the Owner or another contractor,
- .6 Reasonable evidence that Contractor will not achieve Substantial Completion and/or Final Completion by the dates specified in the Supplemental Conditions.
- .7 Failure or refusal of the Contractor to carry out the Work in accordance with or to otherwise substantially or materially comply with the Contract Documents,
- .8 Liens filed or reasonable evidence that a lien may be filed for any portion of the Work,
- .9 Failure or refusal of the Contractor to properly schedule and coordinate the Work, to provide progress schedules, reports and updates, or to provide a recovery schedule when required by the Contract,
- .10 Failure or refusal of the Contractor to fully comply with the provisions of Section 6.2 requiring the Contractor to direct certain Claims to Separate Contractors and to defend and indemnify the Owner and/or the Design Consultant in the event Separate Contractors file certain Claims,
- .11 Failure or refusal of the Contractor to submit the required information on Historically Underutilized Businesses (HUB's),
- .12 Failure or refusal of the Contractor to submit a notarized North Carolina State and County Sales Tax Report,
- .13 Any other breach of the Contract by Contractor which has or is likely to cause monetary damages or loss to Owner, or
- .14 Any other reason authorized by the Contract Documents or by law.

9.6.2 When the above grounds in Paragraph 9.6.1 are removed to the Design Consultant's and Owner's satisfaction, payment shall be made for amounts withheld because of them.

9.7 FAILURE OF PAYMENT

9.7.1 If the Owner does not make payment to the Contractor within the forty-five (45) calendar days after receipt of the Contractor's approved Application for Payment from the Design Consultant through no fault of the Contractor, and the Owner otherwise not being entitled under the Contract Documents or applicable law to withhold payment, then the Contractor may, upon seven (7) additional days' Notice to the Owner, stop the Work until payment of the amount owed according to the Contract Documents has been received. In such event, the Contract Sum shall

be increased by the amount of the Contractor's reasonable costs of shut-down, delay and start-up, which shall be effected by appropriate Change Order as provided herein.

9.8 SUBSTANTIAL COMPLETION

- 9.8.1 When the Contractor considers that the Work, or a designated portion thereof which is acceptable to the Owner, is substantially complete as defined in Paragraph 8.1.3, the Contractor shall prepare for submission to the Owner a list of items which in his opinion are to be completed or corrected and shall request in writing that the Design Consultant and the Owner perform a Substantial Completion inspection. The Design Consultant and the Owner shall review the Contractor's list and shall compile a punch list of items to be corrected and completed. The failure to include any items on such list does not alter the responsibility of the Contractor to complete the Work in accordance with the Contract Documents. When the Design Consultant and the Owner on the basis of an inspection jointly determine that the Work or designated portion thereof is substantially complete, they will then prepare a Certificate of Substantial Completion which shall establish the date of Substantial Completion, shall state the responsibilities of the Owner and the Contractor for security, maintenance, heat, utilities, damage to the Work, and insurance, and shall fix the time within which the Contractor shall complete the items listed therein. Warranties required by the Contract Documents shall commence on the date of Substantial Completion of the Work or designated portion thereof unless otherwise provided in the Certificate of Substantial Completion. The Certificate of Substantial Completion shall be submitted to the Owner and the Contractor for their written acceptance of the responsibilities assigned to them in such Certificate.
- 9.8.2 Upon Substantial Completion of the Work or designated portion thereof and upon application by the Contractor and certification by the Design Consultant, the Owner shall make payment, except retainage held pursuant to Paragraph 9.3.2, for such work or portion thereof, as provided in the Contract Documents unless Contractor is in breach of the Contract in which case Owner may withhold an appropriate amount.
- 9.8.3 The acceptance of Substantial Completion payment shall constitute a waiver of all Claims by the Contractor and its Subcontractors and Sub-subcontractors except those previously made in writing and identified by the Contractor as unsettled at the time the Contractor submits the Application for Payment for Substantial Completion, and except for the retainage sums due at Final Completion. The Contractor shall indemnify and hold the Owner harmless against any Claims by its Subcontractors and Sub-subcontractors that are waived because they were not made in writing and identified by the Contractor as unsettled when the Contractor submitted the Application for Payment for Substantial Completion.
- 9.8.4 The Owner shall have the option to correct or conclude any and all punch list items not completed by the Contractor to the satisfaction of the Design Consultant and the Owner within thirty (30) days from the actual date of Substantial Completion by utilizing its own forces or by hiring others. The cost of such correction of remaining punch list items by the Owner or others shall be deducted from the final payment to the Contractor. If Contractor does not complete certain punch list items within this time period, specified in Paragraph 9.8.4, all warranties and guarantees for such incomplete punch list items shall become effective upon issuance of final payment for the Project. Paragraph 9.8.4 does not limit the Liquidated Damages provisions related to failure to reach Final Completion by the date stipulated in the Contract Documents.
- 9.8.5 The issuance of the Certificate of Substantial Completion does not indicate final acceptance of the Project by the Owner, and the Contractor is not relieved of any responsibility for the Project except as specifically stated in the Certificate of Substantial Completion.

- 9.8.6 Should the Design Consultant and the Owner determine that the Work or a designated portion thereof is not substantially complete, they shall inform the Contractor in writing stating why the Project or designated portion is not substantially complete. The Contractor shall expeditiously complete the Work and shall re-request in writing that the Design Consultant and the Owner perform a Substantial Completion inspection. Costs, if any, associated with such inspection shall be assessed to the Contractor.
- 9.8.7 Certificate of Substantial Completion will not be issued until the following is completed by Contractor:
- .1 Submit Contractor's list of work not yet complete with proposed time for completion signed by Contractor's project superintendent;
 - .2 Submit Certificate of Occupancy;
 - .3 Submit record drawings, maintenance manuals, final project photos, property surveys;
 - .4 Deliver tools, spare parts, extra stock and similar items;
 - .5 Submit warranties, bonds, maintenance agreements and final certifications;
 - .6 Complete start-up testing of all systems and instruction of the Owner's personnel;
 - .7 Coordinate and complete final changeover of permanent locks and transmit keys to Owner;
 - .8 Discontinue and remove temporary facilities from the site;
 - .9 Complete final cleaning;
 - .10 Advise the Owner of pending insurance changeover requirements;
 - .11 Coordinate and complete changeover of security, telephone, cable and other services; and
 - .12 Submit pay application showing 100% complete for work claimed to be substantially complete.
- 9.8.8 The Contractor acknowledges that the Design Consultant and its consultants are only required to conduct up to two (2) comprehensive substantial completion inspections as part of its basic services. If more than two (2) substantial completion inspections are required through no fault of the Design Consultant, the cost of the additional inspections shall be paid by the Contractor.

9.9 FINAL COMPLETION AND FINAL PAYMENT

- 9.9.1 Upon receipt of the documentation required by Section 9.8, and of written Notice that the Work is ready for final inspection and acceptance and upon receipt of a final Application for Payment, the Design Consultant and the Owner will promptly make such inspection and, when they find the Work acceptable under the Contract Documents and the Contract fully performed, the Design Consultant shall issue a final Certification of Payment stating that to the best of their knowledge, information and belief, and on the basis of their observations and inspections, the Work has been completed in accordance with the terms and conditions of the Contract Documents. The final Certification of Payment will constitute that the conditions precedent to

the Contractor's being entitled to final payment as set forth in Section 9.8 have been fulfilled. Payment shall be made to the Contractor in the amount certified by the Design Consultant within forty five (45) calendar days after receipt by the Owner of the final Certification of Payment except for any Work for which the Owner is entitled a credit under the Contract Documents.

9.9.1.1 The Contractor acknowledges that the Design Consultant and its consultants are only required to conduct up to two (2) comprehensive final completion inspections as part of its basic services. If more than two (2) final completion inspections are required through no fault of the Design Consultant, the cost of the additional inspections shall be paid by the Contractor.

9.9.2 Neither the final payment nor the remaining retained percentage shall become due until the Work is free and clear of any and all liens and the Contractor submits to the Owner:

.1 An affidavit that all payrolls, bills for materials and equipment, and other indebtedness connected with the Work for which the Owner or his property might in any way be responsible, have been paid or otherwise satisfied;

.2 Consent of Surety to final payment;

.3 If required by the Owner, other data establishing payment or satisfaction of all such obligations, such as receipts, releases and waivers of liens arising out of the Contract, to the extent and in such form as may be designated by the Owner; and

.4 A written certification that:

.1 The Contractor has reviewed the requirements of the Contract Documents,

.2 The Work has been inspected by the Contractor for compliance with all requirements of the Contract Documents,

.3 Pursuant to this inspection, the Contractor certifies and represents that the Work complies in all respects with the requirements of the Contract Documents,

.4 The Contractor further certifies and represents that all equipment and systems have been installed in accordance with the Contract Documents and have been tested in accordance with the Specification requirements and are operational, and

.5 The Contractor hereby certifies and represents that the Work is complete in all respects and ready for final inspection.

9.9.3 If any Subcontractor refuses to furnish a release or waiver required by the Owner, the Contractor may furnish a bond satisfactory to the Owner to indemnify him against any loss. If any such lien or claim remains unsatisfied after all payments are made, the Contractor shall refund to the Owner all moneys that the latter may be compelled to pay in discharging such lien or claims, including all costs and reasonable attorney's fees. The Owner may withhold from the final payment any sum that the Owner has reason to believe may be needed to satisfy any lien, claim or threat of lien arising from the Work. The Owner may deduct from the final payment an amount equal to any costs, expenses and attorney's fees incurred by the Owner in removing or discharging any liens or claim arising from the Work.

9.9.4 If, after Substantial Completion of the Work, Final Completion thereof is materially delayed

through no fault of the Contractor or by the issuance of Change Orders affecting Final Completion, and the Owner so confirms, the Owner shall, upon application by the Contractor and certification by the Design Consultant, and without terminating the Contract, make payment of the balance due for that portion of the Work fully completed and accepted. If the remaining balance for the portion of the Work not fully completed or corrected is less than the retainage stipulated in the Contract Documents, and if bonds have been furnished as provided in Section 7.4, the written consent of the Surety to the payment of the balance due for that portion of the Work fully completed and accepted shall be submitted by the Contractor to the Design Consultant prior to certification of such payment. Such payment shall be made under the terms and conditions governing final payment, except that it shall not constitute a waiver of Claims.

9.9.5 The making of final payment shall constitute a waiver of all Claims by the Owner against the Contractor except those arising from:

- .1 Unsettled liens, and claims against the Owner or the Design Consultant, or their employees, agents, or representatives;
- .2 Faulty, defective or non-conforming Work;
- .3 Failure of the Work to comply with the requirements of the Contract Documents;
- .4 Terms of any warranties contained in or required by the Contract Documents;
- .5 Damages incurred by the Owner resulting from lawsuits brought against the Owner, the Design Consultant, or their agents, employees or representatives because of failures or actions on the part of the Contractor, his Subcontractors, Sub-subcontractors, or any of their employees, agents or representatives;
- .6 Fraud or bad faith committed by the Contractor or any Subcontractor or supplier during performance of the Work but discovered by Owner after final payment; or
- .7 Claims about which Owner did not have actual knowledge or which increase in scope or amount at the time of final payment.

9.9.6 The acceptance of final payment shall constitute a waiver of all Claims by the Contractor except those previously made in writing and identified by the Contractor as unsettled at the time of the final Application for Payment.

9.9.6.1 Notwithstanding any other provision of the Contract, Owner may withhold from Contractor payment otherwise due, as a result of any losses, expenses costs or damages suffered or anticipated to be suffered by Owner as a result of Contractor's breach of any provision of the Contract, including but not limited to Liquidated Damages or backcharges against Contractor.

9.10 OWNER'S RIGHT TO OCCUPY INCOMPLETE WORK

9.10.1 Should the Project, or any portion thereof, be incomplete for Substantial or Final Completion at the scheduled date or dates, the Owner shall have the right to occupy any portion of the Project. In such an event, the Contractor shall not be entitled to any extra compensation on account of said occupancy by the Owner or by the Owner's use of the Project, nor shall the Contractor interfere in any way with said use of the Project. Further, in such an event, the Contractor shall not be entitled to any extra compensation on account of the Owner's occupancy and use of the Project, nor shall the Contractor be relieved of any responsibilities of the Contract including the

required times of completion. Such occupancy by the Owner shall not, in itself, constitute Substantial or Final Completion.

- 9.10.2 If the Owner exercises his rights under the foregoing and occupies the full Project, then there shall be no Liquidated Damages on account of failure on the Contractor's part to reach Substantial Completion from that date forward. This provision does not affect, however, any Liquidated Damages that would be assessed for any period of time between the contractual date of Substantial Completion and the date of any such occupancy. Further, this provision would have no effect on Liquidated Damages assessed on account of late Final Completion.

ARTICLE 10

PROTECTION OF PERSONS AND PROPERTY

10.1 SAFETY PRECAUTIONS AND PROGRAMS

- 10.1.1 The Owner, the Design Consultant, or their agents, employees or representatives are not responsible for the means, methods, techniques, sequences or procedures utilized by the Contractor, or for safety precautions and programs in connection with the Work. The Contractor shall be solely responsible for initiating, maintaining and supervising all safety precautions and programs in connection with the Work. This requirement applies continuously throughout the Contract performance, until final payment is made and all punch list and warranty work is performed properly, and is not limited to regular working hours.

10.2 SAFETY OF PERSONS AND PROPERTY

- 10.2.1 The Contractor shall take all reasonable precautions for the safety of, and shall provide all reasonable protection to prevent damage, injury or loss to:

- .1 All employees on the Work and all other persons who may be affected thereby;
- .2 All the Work and all materials and equipment to be incorporated therein, whether in storage on or off the site, under the care, custody or control of the Contractor or any of his Subcontractors or Sub-subcontractors, machinery, equipment and all hazards shall be guarded or eliminated in accordance with all applicable safety regulations; and
- .3 Other property at the site or adjacent thereto, including trees, shrubs, lawns, walks, pavements, roadways, structures and overhead or underground utilities not designated for removal, relocation or replacement in the course of construction.

- 10.2.2 The Contractor shall give all notices and comply with all applicable laws, ordinances, permits, rules, regulations and lawful orders of any public authority bearing on the safety or persons or property or their protection from damage, injury or loss.

- 10.2.2.1 The Contractor shall at all times safely guard the Owner's property from injury or losses in connection with the Contract. He shall at all times safely guard and protect his own work and adjacent property as provided by law and the Contract Documents, from damage. All passageways, guard fences, lights and other facilities required for protection by applicable safety regulations must be provided and maintained.

- 10.2.3 The Contractor shall erect and maintain, as required by existing conditions and progress of the

Work, all reasonable safeguards for safety and protection, including posting danger signs and other warnings against hazards, promulgating safety regulations and notifying owners and users of adjacent utilities.

- 10.2.4 When the use or storage of explosives or other hazardous materials or equipment is necessary for the execution of the Work, the Contractor shall exercise the utmost care and shall carry on such activities under the supervision of properly qualified personnel.
- 10.2.5 The Contractor shall promptly remedy at his own cost and expense all damage or loss to any property referred to in Subparagraphs 10.2.1.2 and 10.2.1.3 caused by the Contractor, any Subcontractor, any Sub-subcontractor, or anyone directly or indirectly employed by any of them, or by anyone for whose acts any of them may be liable and for which the Contractor is responsible under Subparagraphs 10.2.1.2 and 10.2.1.3, except damage or loss attributable solely to the acts or omissions of the Owner or Design Consultant or anyone directly or indirectly employed by either of them, or by anyone for whose acts either of them may be liable, and not attributable to the fault or negligence of the Contractor. The foregoing obligations of the Contractor are in addition to his obligations under Section 4.21. The Contractor shall perform such restoration by underpinning, repairing, rebuilding, replanting, or otherwise restoring as may be required or directed by the Owner, or shall make good such damage in a satisfactory and acceptable manner. In case of failure on the part of the Contractor to promptly restore such property or make good such damage, the Owner may, upon two (2) calendar days Notice, proceed to repair, rebuild or otherwise restore such property as may be necessary and the cost thereof, or a sum sufficient in the judgment of the Owner to reimburse the owners of property so damaged, will be deducted from any monies due or to become due the Contractor under the Contract.
- 10.2.6 The Contractor is responsible for the proper packing, shipping, handling and storage (including but not limited to shipment or storage at the proper temperature and humidity) of materials to be incorporated in the Work, so as to insure the preservation of the quality and fitness of the material for proper installation and incorporation in the Work, as required by the Contract Documents. For example, but not by way of limitation, Contractor shall, when necessary, place material on wooden platforms or other hard and clean surfaces and not on the ground and/or place such material under cover in any appropriate shelter or facility. Stored materials or equipment shall be located so as to facilitate proper inspection. Material and equipment which is delivered crated shall remain crated until ready for installation. Lawns, grass plots or other private property shall not be used for storage purposes without the written permission of the Owner or lessee unless otherwise within the terms of the easements obtained by the Owner.
- 10.2.6.1 It shall be the responsibility of the Contractor in his preparation of phasing schedule of work operations after consulting with the other Prime Contractors to designate areas in which each Prime Contractor may store materials. Areas designed shall meet with the approval of the Design Consultant.
- 10.2.7 The Contractor shall give notice in writing at least forty eight (48) hours before breaking ground, to all persons, public utility companies, owners of property having structures or improvements in proximity to site of the Work, superintendents, inspectors, or those otherwise in charge of property, streets, water pipes, gas pipes, sewer pipes, telephone cables, electric cables, railroads or otherwise, who may be affected by the Contractor's operation, in order that they may remove any obstruction for which they are responsible and have representative on site to see that their property is properly protected. Such notice does not relieve the Contractor of responsibility for all damages, claims, or defense or indemnification of all actions against Owner resulting from performance of such work in connection with or arising out of Contract.

- 10.2.8 The Contractor shall investigate, locate, mark and protect all utilities encountered or to be encountered while performing the Work, whether indicated on the Drawings or not. The Contractor shall maintain utilities in service until moved or abandoned. The Contractor shall exercise due care when excavating around utilities and shall restore any damaged utilities to the same condition or better as existed prior to starting the Work, at no cost to the Owner. The Contractor shall maintain operating utilities or other services, even if they are shown to be abandoned on the Contract Drawings, in service until new facilities are provided, tested and ready for use.
- 10.2.9 The Contractor shall return all improvements on or about the site and adjacent property which are not shown to be altered, removed or otherwise changed to conditions which existed prior to starting the Work. The Contractor shall video record all areas or otherwise document the conditions existing at the site and in and around existing buildings prior to starting the Work. Submit documentation to the Design Consultant prior to beginning the Work.
- 10.2.10 The Contractor shall protect the Work, including but not limited to, the site, stored materials and equipment, excavations, and excavated or stockpiled soil or other material, intended for use in the Work, and shall take all necessary precautions to prevent or minimize damage to same or detrimental effect upon his performance or that of his Subcontractors, caused by or due to rain, snow, ice, run-off, floods, temperature, wind, dust, sand and flying debris; for example, but not by way of limitation, Contractor shall, when necessary, utilize temporary dikes, channels or pumping to carry-off divert or drain water, and shall as necessary tie-down or otherwise secure the Work and employ appropriate covers and screens.
- 10.2.11 The Contractor shall designate a responsible member of his organization at the site whose duty shall be the prevention of accidents and the protection of material, equipment and property. This person shall be the Contractor's superintendent unless otherwise designated by the Contractor in writing to the Owner.
- 10.2.12 The Contractor shall not load or permit any part of the Work to be loaded so as to endanger its safety.
- 10.2.13 Notification to the Contractor by the Owner or the Design Consultant of a safety violation will in no way relieve the Contractor of sole and complete responsibility for the correctness of said violation or of sole liability for the consequences of said violation.
- 10.3 EMERGENCIES
- 10.3.1 In any emergency affecting the safety of persons or property, the Contractor shall act, at his discretion, to prevent threatened damage, injury or loss. The Contractor shall notify the Owner of the situation and all actions taken immediately thereafter. If, in the opinion of the Contractor, immediate action is not required, the Contractor shall notify the Owner of the emergency situation and proceed in accordance with the Owner's instructions. Provided, however, if any loss, damage, injury or death occurs that could have been prevented by the Contractor's prompt and immediate action, the Contractor shall be fully liable for all costs, damages, claims, actions, suits, attorney's fees and all other expenses arising therefrom or relating thereto.

ARTICLE 11

INSURANCE

11.1 CONTRACTOR'S LIABILITY INSURANCE

11.1.1 The Contractor shall purchase and maintain in companies properly licensed by the Insurance Department of the State of North Carolina and acceptable to the Owner such insurance as will protect him, the Owner, and the Owner's agents, representatives, and employees from claims set forth below which may arise out of or result from the Contractor's operations under the Contract, whether such operations be by himself or by any Subcontractor or by anyone directly or indirectly employed by any of them, or by anyone for whose acts any of them may be liable:

- .1 Claims under workers' or workmen's compensation, disability benefit and other similar employee benefit acts (with Workmen's Compensation and Employer's Liability Insurance in amounts not less than those necessary to meet the statutory requirements of the state(s) having jurisdiction over any portion of the Work);
- .2 Claims for damages because of bodily injury, sickness or disease, or death of his employees; the Contractor will require his Subcontractors to similarly provide Workmen's Compensation Insurance for all of the latter's employees;
- .3 Claims for damages because of bodily injury, sickness or disease, or death of any person other than his employees;
- .4 Claims for damages insured by usual personal injury liability coverage which are sustained (1) by any person as a result of an offense directly or indirectly related to the employment of such person by the Contractor, or (2) by any other person;
- .5 Claims for damages, other than to the Work itself, because of injury to or destruction of tangible property, including loss of use resulting therefrom; and
- .6 Claims for damages because of bodily injury or death of any person or property damage arising out of the ownership, maintenance or use of any motor vehicle.

11.1.2 The insurance required by Paragraph 11.1.1 shall be primary and non-contributing to any insurance possessed or procured by the Owner, and limits of liability shall be not less than those set forth in these General Conditions of the Contract or required by law, whichever is greater.

11.1.3 The insurance required by the Contract shall include contractual liability insurance applicable to the Contractor's obligations under the Contract

11.1.4 Without limiting the above during the term of the Contract, the Contractor and each Subcontractor shall, at their own expense, purchase and maintain the following insurance with companies properly licensed by the Insurance Department of the State of North Carolina and satisfactory to the Owner.

- .1 Worker's Compensation including Occupational Disease and Employer's Liability Insurance.
 - .1 Statutory - Amount and coverage as required by State of North Carolina Worker's Compensation laws.

- .2 Employer's Liability
 - \$1,000,000 Each Accident
 - \$1,000,000 Policy Limit
 - \$1,000,000 Each Employee

- .2 Commercial General Liability (Occurrence Form) - The Contractor shall provide during the life of the Contract such Commercial General Liability (Occurrence Form) Insurance as shall protect him and any Subcontractor performing work under the Contract from claims for damages for Bodily Injury including accidental death, as well as from claims for Property Damage which may arise from operations under the Contract, whether such operations be by himself or by any Subcontractor or by anyone directly or indirectly employed by either of them. This insurance shall be on the Standard Insurance Services Office, Inc. (ISO) Commercial Liability Occurrence Form or other form reasonable acceptable to Owner. The Contractor shall procure insurance coverage for direct operations, sublet work, elevators, contractual liability and completed operations with limits not less than those stated below:
 - .1 A Combined Single Limit for Bodily Injury, Property Damage and Personal Injury of:
 - Limits of Insurance
 - \$2,000,000 General Aggregate (except Products – Completed Operations) Limit
 - \$2,000,000 Products – Completed Operations Aggregate Limit
 - \$1,000,000 Personal and Advertising Injury Limit
 - \$1,000,000 Each Occurrence Limit

- .3 Property Damages, including Broad Form Property Damage and Explosion, Collapse, Underground property damage coverages, and blasting, where necessary;
- .4 Completed Operations Liability: Continuous coverage in force for one year after completion of the Work;
- .5 Commercial Automobile Insurance, including coverage for owned, non-owned and hired vehicles - with limits not less than those stated below:
 - .1 A Combined Single Limit for Bodily Injury and Property Damage of \$1,000,000.
- .6 Umbrella Liability Insurance: Policy to "pay on behalf of the Insured"
 - Limits of Liability:
 - .1 Contract Amount: \$1,000,000-\$2,000,000:
 - Requires Umbrella Liability Insurance Limit of \$1,000,000.
 - .2 Contract Amount: \$2,000,000 and above:
 - Requires Umbrella Liability Insurance Limit of \$2,000,000.

- 11.1.5 The insurance required by Section 11.1 shall be written for not less than any limits of liability specified in the Contract Documents, or required by law, whichever is greater.
- 11.1.6 Certificates of Insurance acceptable to the Owner shall be filed with the Owner prior to commencement of the Work. These Certificates shall contain a provision that coverages afforded under the policies will not be canceled until at least thirty (30) days' prior written Notice

has been given to the Owner. Failure to provide such Notice shall not limit the liability of the Insurer, its agents or representatives.

- 11.1.7 All insurance policies required in this Article, except Worker's Compensation and Commercial Automobile, shall name the Owner as additional named insured for the insurance.
- 11.1.8 The Contractor shall not commence the Work under the Contract until he has obtained all the insurance required hereunder and such insurance has been approved by the Owner, nor shall the Contractor allow any Subcontractor to commence work on his subcontract until all similar insurance required of the Subcontractor has been so obtained and approved. Approval of the insurance by the Owner shall not relieve or decrease the liability of the Contractor hereunder.
- 11.1.9 The Commercial General Liability and Workers Compensation Policies provided by the Contractor shall have endorsements waiving subrogation against the Owner.

11.2 PROPERTY INSURANCE

- 11.2.1 The Contractor shall purchase and at all times maintain such insurance as will protect the Contractor, the Owner, Subcontractors and Sub-subcontractors from loss or damage to the Work or property in the course of construction, including all machinery, materials and supplies on the premises or in transit thereto and intended to become a part of the finished Work until Final Completion. This insurance shall be in the form of "Builders Risk Covered Cause of Loss Form", or equivalent form, to include but not limited to theft, collapse, earth movement, flood, and portions of the Work stored on site, off site and in transit. Any deductible provision in such insurance shall not exceed ten thousand dollars (\$10,000). Notwithstanding any such deductible provision, the Contractor shall remain solely liable for the full amount of any item covered by such insurance. Such insurance shall be in the initial Contract Sum and shall be increased at Contractor's expense in the amount of all additions to the Contract Sum. Such insurance shall include interests of the Owner, the Contractor, Subcontractors and Sub-subcontractors in the Project.
- 11.2.2 Any loss insured under Paragraph 11.2.1 is to be adjusted with the Owner and made payable to the Owner as trustee for the insureds, as their interests may appear, subject to the requirements of Paragraph 11.2.4. The Contractor shall pay each Subcontractor a just share of any insurance moneys received by the Contractor, and by appropriate agreement, written where legally required for validity, shall require each Subcontractor to make payments to his Sub-subcontractors in similar manner.
- 11.2.3 The Owner and Contractor waive all rights against each other for damages caused by fire or other perils to the extent their Claims are covered by insurance obtained pursuant to this Section 11.2, or any other property insurance applicable to the Work, except such rights as they may have to the proceeds of such insurance. The Contractor shall require, by appropriate agreement, written where legally required for validity, similar waivers in favor of the Owner and the Contractor by Subcontractors and Sub-subcontractors. With respect to the waiver of rights of recovery, the term Owner shall be deemed to include, to the extent covered by property insurance applicable thereto, his consultants, employees, and agents and representatives. The Contractor waives as against any Separate Contractor described in Article 6, all rights for damages caused by fire or other perils in the same manner as is provided above as against the Owner. The Owner shall require, by appropriate agreement, written where legally required for validity, similar waivers in favor of the Contractor by any Separate Contractor and his subcontractors and sub-subcontractors.

- 11.2.4 The Owner as trustee shall have power to adjust and settle any loss with the insurers unless one of the parties in interest shall object in writing within five (5) days after the occurrence of loss to the Owner's exercise of this power, and if such objection is made, the matter shall be decided by a court of competent jurisdiction or as the parties in interest otherwise agree. The Owner as trustee shall, in that case, make settlement with the insurers in accordance with the orders of the court or as otherwise agreed by the parties in interest.
- 11.2.5 If the Owner finds it necessary to occupy or use a portion or portions of the Work prior to Substantial Completion thereof, such occupancy or use shall not commence prior to a time mutually agreed to by the Owner and Contractor and to which the insurance company or companies providing the property insurance have consented by endorsement to the policy or policies. This insurance shall not be canceled or lapsed on account of such partial occupancy or use. Consent of the Contractor and of the insurance company or companies to such occupancy or use shall not be unreasonably withheld.
- 11.2.6 The Contractor bears the risk of loss or damage to the Work, the Project, materials stored on site or off site, and Owner's improvements and property under Contractor's control, both during construction and prior to Substantial Completion.
- 11.3 EFFECT OF SUBMISSION OF CERTIFICATES
- 11.3.1 The Owner shall be under no obligation to review any Certificates of Insurance provided by the Contractor or to check or verify the Contractor's compliance with any and all requirements regarding insurance imposed by the Contract Documents. The Contractor is fully liable for the amounts and types of insurance required herein and is not excused should any policy or certificate of insurance provided by the Contractor not comply with any and all requirements regarding insurance imposed by the Contract Documents.
- 11.4 FAILURE OF COMPLIANCE
- 11.4.1 Should the Contractor fail to provide and maintain in force any and all insurance, or insurance coverage required by the Contract Documents or by law, or should a dispute arise between Owner and any insurance company of Contractor over policy coverage or limits of liability as required herein, the Owner shall be entitled to recover from the Contractor all amounts payable, as a matter of law, to Owner or any other parties, had the required insurance or insurance coverage been in force. Said recovery shall include, but is not limited to interest for the loss of use of such amounts of money, plus all attorney's fees, costs and expenses incurred in securing such determination and any other consequential damages arising out of the failure of the Contractor or insurance company to comply with the provisions of the Contract Documents, or any policy required hereby, or any other requirements regarding insurance imposed by law. Nothing herein shall limit any damages for which Contractor is responsible as a matter of law.
- 11.5 OWNER'S INSURANCE
- 11.5.1 Property Insurance: The Owner, at his option, may purchase and maintain such insurance as will insure him against loss of use of his property due to fire or other hazards, however caused.
- 11.5.2 Commercial Public Liability Insurance: The Owner, at his option, may purchase and maintain insurance which will insure and protect him against claims involving bodily injury and property damage to the public. The Owner does not request his insurer to waive any right of subrogation against the Contractor from claims under this coverage.

11.6 LICENSED INSURANCE COMPANIES

11.6.1 All insurance companies providing the above insurance shall be licensed by the Insurance Department of the State of North Carolina and have a minimum AM Best "A" rating or similar rating from another rating agency reasonably acceptable to Owner.

ARTICLE 12

CHANGES IN THE WORK

12.1 GENERAL PROVISIONS RELATED TO CHANGES

12.1.1 A Construction Change Directive is a document issued pursuant to this Paragraph 12.1.1. The Owner may, at any time, without the agreement of the Contractor, by written order signed by the Owner and Design Consultant designated or indicated to be a Construction Change Directive, make any Changes in the Work or add to or subtract from the Work within the general scope of the Contract. A Change in the Work is defined as changes within the general scope of the Contract, including, but not limited to changes:

- .1 In the Specifications or Drawings;
- .2 In the sequence, method or manner of performance of the Work;
- .3 In the Owner-furnished facilities, equipment, materials, services or site; or
- .4 Directing acceleration in the performance of the Work.

12.1.2 A Change Order is a document executed pursuant to this Paragraph 12.1.2. The Owner and Contractor may agree to Changes in the Work, the Contract Sum, the Contract Time and any other change in the Contract by written agreement signed by Owner, Contractor and Design Consultant designated or indicated to be a Change Order. If the Contractor, subsequent to the issuance of a Construction Change Directive, agrees to its terms including any applicable adjustment to the Contract Sum and Contract Time, Contractor shall sign it and it shall become a Change Order.

12.1.3 The Contractor shall not be entitled to any amount for indirect costs, damages or expenses of any nature, including, but not limited to, so-called "impact" costs, labor inefficiency, wage, material or other escalations beyond the prices upon which the Proposal is based and to which the parties have agreed pursuant to the provisions of Article 12, and which the Contractor, its Subcontractors or Sub-subcontractors or any other person may incur as a result of delays, interferences, suspensions, changes in sequence or the like, for whatever cause, whether reasonable or unreasonable, foreseeable or unforeseeable, or avoidable or unavoidable, arising from the performance of any and all Changes in the Work performed pursuant to this Article 12, unless the delay is caused solely by the Owner or its agent. It is understood and agreed that the Contractor's sole and exclusive remedy in the event the delay is caused solely by the Owner or its agent shall be recovery of his direct costs as compensable hereunder and an extension of the Contract Time, but only in accordance with the provisions of the Contract Documents. The phrase "Owner or its agent" as used in the Contract, does not include the Prime Contractors or their Subcontractors.

- 12.1.4 No Claim by the Contractor shall be allowed if asserted after final payment under this Contract. No Claim relating to or flowing from a particular change shall be allowed after execution of the Change Order relating to that change or commencement of the change by the Contractor except as specifically provided in Paragraph 12.2.4.
- 12.1.5 If any dispute should arise between the parties with respect to an increase or decrease in the Contract Sum or an expansion or contraction in the Contract Time as a result of a Change in the Work, the Contractor shall not suspend performance of a Change in the Work or the Work itself unless otherwise so ordered by the Owner in writing. The Owner shall, however, pay to the Contractor up to the Owner's reasonable estimated value of the Change in the Work, regardless of the dispute, if said Change in the Work will result in an increase in the Contract Sum; and the Owner shall have the right to withhold payment from the Contractor in an amount up to the Owner's reasonable estimated value of the Change in the Work, regardless of the dispute, if said Change in the Work will result in a decrease in the Contract Sum.
- 12.1.6 No Change in the Work shall be performed without a fully executed Change Order to the Contract a fully executed Construction Change Directive or other Modification to the Contract.
- 12.1.7 If the Contractor intends to assert a Claim under this Article, he must, within ten (10) days after receipt of a Construction Change Directive, Notify the Owner by written statement setting forth the specific nature and cost of such Claim, unless this period is extended by the Owner. The statement of Claim shall include all direct, indirect and impact costs associated with the change, as well as the Contractor's estimate of the schedule impact of the change, if any. The Contractor and its Subcontractors shall not be entitled to reimbursement for any Claims that are not submitted in strict conformance with the Contract. The Contractor shall indemnify and hold the Owner harmless against any Claims by Subcontractors that are waived because they are not submitted in strict conformance with the Contract.
- 12.2 OWNER DIRECTED CHANGES REQUIRING AN INCREASE IN CONTRACT SUM.
(For decreases in Contract Sum, refer to Section 12.6)
- 12.2.1 If the Change in the Work will result in an increase in the Contract Sum, the Owner shall have the right to require the performance thereof on a lump sum basis, a unit price basis or a time and material basis, all as hereinafter more particularly described (the right of the Owner as aforesaid shall apply with respect to each such Change in the Work).

If the Owner elects to have the Change in the Work performed on a lump sum basis, its election shall be based on a lump sum Proposal which shall be submitted by the Contractor to the Owner within ten (10) days of the Contractor's receipt of a request therefore (but the Owner's request for a lump sum Proposal shall not be deemed an election by the Owner to have the Change in the Work performed on a lump sum basis). The Contractor's Proposal shall be itemized and segregated by labor and materials for the various components of the Change in the Work (no aggregate labor total will be acceptable) and shall be accompanied by signed Proposals of any Subcontractors who will perform any portion of the Change in the Work and of any persons who will furnish materials or equipment for incorporation therein. The Proposal shall also include the Contractor's estimate of the time required to perform said changes. The Contractor shall provide any documentation that may be requested by the Owner or Architect to support the change proposal, including but not limited to payroll records, insurance rates, material quotes, and rental quotes.

The portion of the Proposal relating to labor, whether by the Contractor's forces or the forces of any of its Subcontractors, may include reasonably anticipated gross wages of job site labor,

including foremen, who will be directly involved in the Change in the Work (for such time as they will be so involved), plus payroll costs (including premium costs of overtime time, if overtime is anticipated, Social Security, Federal or State unemployment insurance taxes and fringe benefits required by collective bargaining agreements entered into by the Contractor or any such Subcontractor in connection with such labor) and up to fifteen percent (15%) of such anticipated gross wages, but not payroll costs, as overhead and profit for the Contractor or any such Subcontractor, as applicable (said overhead and profit to include all supervision except foremen). Payroll costs are limited to 39% of the net pay of the worker.

The portion of the Proposal relating to materials may include the reasonably anticipated direct costs to the Contractor or to any of its Subcontractors of materials to be purchased for incorporation in the Change in the Work, plus transportation and applicable sales and use taxes and up to fifteen percent (15%) of said direct material costs as overhead and profit for the Contractor or any such Subcontractor (said overhead and profit to include all small tools), and may further include the Contractor's and any of its Subcontractor's reasonably anticipated rental costs in connection with the Change in the Work (either actual or discounted local published rates), plus up to eight percent (8%) thereof as overhead and profit for the Contractor or any such Subcontractors, as applicable. The Contractor shall provide an itemized breakdown of all transportation and shipping costs, including receipts documenting the expenses. Notwithstanding the above, overhead and profit shall not be applied to any sales tax paid for any purpose or to any transportation or shipping costs incurred by the Contractor or any subcontractor. If any of the items included in the lump sum Proposal are covered by unit prices contained in the Contract Documents, the Owner may, if it requires the Change in the Work to be performed on a lump sum basis, elect to use these unit prices in lieu of the similar items included in the lump sum Proposal, in which event an appropriate deduction will be made in the lump sum amount prior to the application of any allowed overhead and profit percentages. No overhead and profit shall be applied to any unit prices.

The lump sum Proposal may include up to eight percent (8%) of the amount which the Contractor will pay to any of its Subcontractors for Changes in the Work as overhead and profit for the Contractor. The Contractor shall not be reimbursed for the costs of the Subcontractors' Payment and Performance Bonds, as such bonding is not required by the Owner.

- 12.2.2 In the event that the Contractor fails to submit his Proposal within the designated period, the Owner may order the Contractor to proceed with the Change to the Work and the Contractor shall so proceed. The Owner shall unilaterally determine the reasonable cost and time to perform the Work in question, which determination shall be final and binding upon the Contractor. The Contractor may dispute such action in accordance with the Article 15.
- 12.2.3 In the event that the parties are unable to agree as to the reasonable cost and time to perform the Change in the Work based upon the Contractor's Proposal and the Owner does not elect to have the Change in the Work performed on a time and material basis, the Owner may choose to make a determination of the reasonable cost and time to perform the Change in the Work, based upon its own estimates, the Contractor's submission or a combination thereof. A Construction Change Directive shall be issued in this case for the amounts of cost and time determined by the Owner and shall become final and binding upon the Contractor, subject to Contractor's right to dispute such action in accordance with Article 15. Owner has the right to direct by Construction Change Directive a Change in the Work, which is the subject of such Change Order. Failure of the parties to reach agreement regarding the cost and time of the performing the Construction Change Directive, shall not relieve the Contractor from performing the Change in the Work promptly and expeditiously.

12.2.3.1 The Owner reserves the right to reject the Contractor's Proposal for a Change in the Work and to elect to perform said Work using a Separate Contractor. Under such circumstances, all provisions of Article 6 shall be in force.

12.2.4 If the Owner elects to have the Change in the Work performed on a time and material basis, the same shall be performed, whether by the Contractor's forces or the forces of any of its Subcontractors or Sub-subcontractors, at actual cost to the entity performing the Change in the Work (without any charge for administration, clerical expense, supervision or superintendence of any nature whatsoever, including foremen, or the cost, use or rental of tools or plant), plus fifteen percent (15%) thereof as the total overhead and profit (except that said fifteen percent (15%) shall not be applied against any payroll costs, as set forth in Paragraph 12.2.1.) The Contractor shall submit to the Owner daily time and material tickets, on a daily basis to include the identification number assigned to the Change in the Work, the location and description of the Change in the Work, the classification of labor employed (and names and social security numbers), the materials used, the equipment rented (not tools) and such other evidence of cost as the Owner may require. The Owner may require authentication of all time and material tickets and invoices by persons designated by the Owner for such purpose. The failure of the Contractor to secure any required authentication shall, if the Owner elects to treat it as such, constitute a waiver by the Contractor of any Claim for the cost of that portion of the Change in the Work covered by a non-authenticated ticket or invoice; provided, however, that the authentication of any such ticket or invoice by the Owner shall not constitute an acknowledgment by the Owner that the items thereon were reasonably required for the Change in the Work.

12.2.5 No overhead and profit will be paid by the Owner on account of a Change in the Work except as specifically provided in Section 12.2. Overhead and profit, as allowed under Section 12.2, shall be deemed to include all costs and expenses which the Contractor or any of its Subcontractors may incur in the performance of a Change in the Work and which are not otherwise specifically recoverable by them pursuant to Section 12.2.

12.3 CONTRACTOR NOTICE OF CHANGE

12.3.1 If the Contractor or any of its Subcontractors asserts that any event or occurrence has caused a Change in the Work which change causes an increase or decrease in the Contractor's or its Subcontractors cost or the time required for the performance of any part of the Work under the Contract, including Work not affected directly by the change, the Contractor shall, within ten (10) days of such event, give the Owner written Notice as herein required. Said Notice shall include the instructions or circumstances that are the basis of the Claim and the Contractor's best estimate of the cost and time involved.

12.4 MINOR CHANGES IN THE WORK

12.4.1 The Owner shall have authority to order minor Changes in the Work not involving an adjustment in the Contract Sum or an extension of the Contract Time and not inconsistent with the intent of the Contract Documents. Such changes shall be effected by written order, and shall be binding on the Owner and the Contractor. The Contractor shall carry out such written orders promptly.

12.4.2 The Contractor shall not perform any Changes in the Work unless authorized in writing by the Design Consultant or Owner.

12.5 DIFFERING SITE CONDITIONS

12.5.1 Should the Contractor encounter subsurface and/or latent conditions at the site materially differing from those shown on the Drawings or indicated in the Specifications or differing materially from those ordinarily encountered and generally recognized as inherent in work of the character provided for in this Contract, or different from that shown on surveys or tests provided in the bid materials at the time the Owner solicited bids from the construction of the Project, he shall immediately give Notice to the Owner of such conditions before they are disturbed. The Owner and the Design Consultant shall thereupon promptly investigate the conditions and if they find that they materially differ from those shown on the Drawings or indicated in the Specifications, they shall at once make such changes in the Drawings and/or Specifications as they may find necessary. Any increase or decrease of cost resulting from such changes shall be adjusted in the manner provided herein for adjustments as to extra and/or additional work and changes. However, neither the Owner nor the Design Consultant shall be liable or responsible for additional work, costs or Changes to the Work due to material differences between actual conditions and any geotechnical, soils and other reports, surveys and analyses made available for the Contractor's review at the time the Owner solicited bids for the construction of the Project.

12.6 OWNER DIRECTED CHANGES REQUIRING A DECREASE IN CONTRACT SUM.

12.6.1 If the Change in the Work will result in a decrease in the Contract Sum, the Owner may request a quotation by the Contractor of the amount of such decrease. The following provisions shall apply:

The portion of the Proposal relating to labor, whether by the Contractor's forces or the forces of any of its Subcontractors, shall include reasonably anticipated gross wages of job site labor, including foremen, who would have been directly involved in the Work that has been deleted from the Contract, (for such time as they would have been so involved), plus payroll costs (including premium costs of overtime time, if overtime was anticipated, Social Security, Federal or State unemployment insurance taxes and fringe benefits required by collective bargaining agreements entered into by the Contractor or any such Subcontractor in connection with such labor) and seven percent (7%) of such anticipated gross wages, but not payroll costs, as overhead and profit not incurred or earned by the Contractor or any such Subcontractor, as applicable (said overhead and profit to include all supervision except foremen).

The portion of the Proposal relating to materials shall include the reasonably anticipated direct costs which would have been incurred by the Contractor or to any of its Subcontractors of materials which would have been purchased for incorporation in the Work but which has been deleted from the Contract, plus transportation and applicable sales and use taxes which will be avoided and seven percent (7%) of said direct material costs as overhead and profit not incurred or earned by the Contractor or any such Subcontractor (said overhead and profit to include all small tools), and shall further include the Contractor's and any of its Subcontractor's reasonably anticipated rental costs which will be avoided (either actual or discounted local published rates), plus five percent (5%) thereof as overhead and profit not incurred or earned by the Contractor or any such Subcontractors, as applicable. If any of the items included in the lump sum Proposal are covered by unit prices contained in the Contract Documents, the Owner may elect to use these unit prices in determining the amount of reduction to the Contract Sum as a result of a deletion of Work from the Contract. No overhead and profit shall be applied to any unit prices for purposes of calculation such reduction in the Contract Sum.

The lump sum Proposal for Work which would have been performed by any Subcontractors shall include four percent (4%) of that amount as an estimate of the Contractor's overhead and profit that will not be earned by Contractor due to the decrease in the Contract Sum.

The Contractor's quotation shall be forwarded to the Owner within ten (10) days of the Owner's request and, if acceptable to the Owner, shall be incorporated in the Change Order. If not acceptable, the parties shall make every reasonable effort to agree as to the amount of such decrease, which may be based on a lump sum properly itemized, on unit prices stated in the Contract Documents and/or on such other basis as the parties may mutually determine. If the parties are unable to so agree, the amount of such decrease shall be the total of the estimated reduction in actual cost of the Work, as determined by the Owner in its reasonable judgment, plus overhead and profits stated above. This shall become final and binding upon the Contractor, subject to Contractor's right to dispute such action in accordance with the Article 15.

ARTICLE 13

UNCOVERING AND CORRECTION OF WORK

13.1 UNCOVERING OF WORK

13.1.1 If any portion of the Work is covered contrary to the request of the Owner or the Design Consultant or to requirements specifically expressed in the Contract Documents or to requirements of applicable construction permits, it must, if required in writing by the Owner, be uncovered for his observation and shall be replaced at the Contractor's expense.

13.1.2 If any other portion of the Work has been covered which the Design Consultant or the Owner has not specifically requested to observe prior to being covered, either may request to see such portion of the Work and it shall be uncovered by the Contractor. If such Work be found in accordance with the Contract Documents, the cost of uncovering and replacement shall, by appropriate Change Order, be charged to the Owner. If such Work be found not in accordance with the Contract Documents, the Contractor shall pay such costs unless it is found that this condition was caused by the Owner, in which event the Owner shall be responsible for the payment of such costs. If such condition was caused by a Separate Contractor, Contractor may proceed against and only against, said Separate Contractor as provided in Article 6. Any costs to the Owner pursuant to this Paragraph shall be determined in accordance with the provisions of Article 12.

13.2 CORRECTION OF WORK

13.2.1 The Contractor shall promptly reconstruct, replace or correct portions of the Work rejected by the Design Consultant or Owner as defective or as failing to conform to the Contract Documents or as not in accordance with the guarantees and warranties specified in the Contract Documents whether observed before or after Substantial Completion and whether or not fabricated, installed or completed. The Contractor shall bear all costs of correcting such rejected portions of the Work, including compensation for the Design Consultant's and the Owner's additional construction management services made necessary thereby.

13.2.2 The Contractor, unless removal is waived by the Owner, shall remove from the site all portions of the Work which are defective or non-conforming, or if permitted or required, he shall correct such portions of the Work in place at his own expense promptly after receipt of Notice, and such rejected Work shall not thereafter be tendered for acceptance unless the former rejection or requirement for correction is disclosed.

13.2.3 If the Contractor does not proceed with the correction of such defective or non-conforming portions of the Work within a reasonable time fixed by written Notice from the Owner or Design

Consultant, the Owner may either (1) by separate contract or otherwise replace or correct such portions of the Work and charge the Contractor the cost incurred by the Owner thereby and remove and store the materials or equipment at the expense of the Contractor, or (2) terminate this Contract for default as provided in Section 14.3, or both, or take any other measure allowed by law.

13.2.4 The Contractor shall bear the cost of making good all work of the Owner or Separate Contractors destroyed or damaged by such correction or removal.

13.2.5 Nothing contained in this Section 13.2 shall be construed to establish a period of limitation with respect to any other obligation which the Contractor might have under the Contract Documents, including Section 4.6 hereof. The establishment of the time period of one year after the date of Substantial Completion or such longer period of time as may be prescribed by law or by the terms of any warranty required by the Contract Documents relates only to the specific obligation of the Contractor to correct the Work, and has no relationship to the time within which his obligation to comply with the Contract Documents may be sought to be enforced, nor to the time within which proceedings may be commenced to establish the Contractor's liability with respect to his obligations.

13.3 ACCEPTANCE OF DEFECTIVE OR NON-CONFORMING WORK

13.3.1 If the Owner prefers to accept defective or non-conforming Work, he may do so instead of requiring its removal and correction, in which case a Change Order will be issued to reflect a reduction in the Contract Sum where appropriate and equitable, or the Owner may elect to accept payment in materials or services, in lieu of a reduction in the Contract Sum. If the amount of a reduction is determined after final payment, it shall be paid to the Owner by the Contractor.

ARTICLE 14

TERMINATION OF THE CONTRACT

14.1 TERMINATION BY THE CONTRACTOR

14.1.1 If the Work is stopped for a period of one hundred twenty (120) days by the Owner or under an order of any court or other public authority having jurisdiction, or as a result of an act of government, such as a declaration of a national emergency making materials unavailable, and through no act or fault of the Contractor or a Subcontractor or their agents or employees or any other persons performing any of the Work under a contract with the Contractor, then the Contractor may, upon seven (7) additional days' written Notice to the Owner and the Design Consultant, terminate the Contract and recover from the Owner payment on a quantum merit basis, for all Work executed for which Contractor has not previously been paid, less any amounts Contractor may owe Owner under the Contract Documents and less any amounts Owner is entitled to withhold from Contractor or backcharge to the Contractor under the Contract Documents or pursuant to law. The Contractor shall not be entitled to collect and hereby expressly waives any overhead or profit on Work not performed and any damages related to that portion of the Contract which has been terminated.

14.2 TERMINATION FOR CONVENIENCE OF THE OWNER

14.2.1 The Owner may, at any time upon ten (10) days written Notice to the Contractor and to the Contractor's Surety, which Notice shall specify that portion of the Work to be terminated and the date said termination is to take effect, terminate (without prejudice to any right or remedy of

the Owner) the whole or any portion of the Work for the convenience of the Owner. The Contractor's sole remedy, in the event of such termination, will be the allowable termination costs permitted by Section 14.4. Contractor shall include termination clauses identical to Article 14 in each of his subcontracts.

14.3 DEFAULT TERMINATION

14.3.1 Ten (10) days after written Notice is mailed to the Contractor and to the Contractor's Surety, the Owner may terminate (without prejudice to any right or remedy of the Owner or any subsequent buyer of any portion of the Work) the employment of the Contractor and his right to proceed either as to the whole or any portion of the Work required by the Contract Documents and may take possession of the Work and complete the Work by contract or otherwise in any one of the following circumstances:

- .1 If the Contractor or its Surety refuses or fails to prosecute the Work or any separable part thereof with such diligence as will ensure the Substantial and Final Completion of the Work by the dates specified in the Supplemental Conditions for Substantial and Final Completion or fails to complete the Work or remedy a default within said period;
- .2 If the Contractor is in material default in carrying out any provisions of the Contract;
- .3 If the Contractor fails to supply a sufficient number of properly skilled workers or proper equipment or materials;
- .4 If the Contractor fails to make prompt payment to Subcontractors or for materials or labor, unless he otherwise provides the Owner satisfactory evidence that payment is not legally due;
- .5 If the Contractor disregards laws, permits, ordinances, rules, regulations or orders of any public authority having jurisdiction, or fails to follow the instructions of the Owner;
- .6 If the Contractor substantially violates any provisions of the Contract Documents; or
- .7 If the Contractor refuses or fails to properly schedule, plan, coordinate and execute the Work, as specified herein, so as to perform the Work within the specified Completion Dates, or to provide scheduling or related information, revisions and updates as required by the Contract Documents.

14.3.2 The right of the Contractor to proceed shall not be so terminated under this Section 14.3 if the delays in the completion of the Work are due to unforeseeable causes beyond the control and without the fault or negligence of the Contractor or his Subcontractors as specifically set forth in Section 8.3 hereof.

14.3.3 If, after the Contractor has been terminated for default pursuant to Section 14.3, it is determined that none of the circumstances set forth in Paragraph 14.3.1 exist, then such termination shall be considered a termination for convenience pursuant to Section 14.2. In such case, the Contractor's sole remedy will be the costs permitted by Section 14.4.

14.3.4 If the Owner so terminates the employment of the Contractor due to the Contractor's default, the Contractor shall not be entitled to receive any further payment until the Work is finished. If the unpaid balance of the compensation to be paid to the Contractor hereunder shall exceed the expense of so completing the Work (including compensation for additional managerial,

administrative, consultant and inspection services, attorney's fees and any damages for delay) such excess shall be paid to the Contractor.

14.3.5 If such expenses referenced in Paragraph 14.3.1, shall exceed the unpaid balance, the Contractor and his sureties shall be liable to the Owner for such excess. If the right of the Contractor to proceed with the Work is partially or fully terminated, the Owner may take possession of and utilize in completing the Work such materials, appliances, supplies, plant and equipment as may be on the site of the terminated portion of the Work and necessary for the completion of the Work. If the Owner does not fully terminate the right of the Contractor to proceed, the Contractor shall continue to perform the part of the Work that is not terminated.

14.3.6 If the Owner terminates the whole or any part of the Work pursuant to Section 14.3, the Owner may procure, upon such terms and in such manner as the Owner may deem appropriate, supplies or services similar to those so terminated, and the Contractor shall be liable to the Owner for any excess costs for such similar supplies or services. The Contractor shall continue the performance of the Contract to the extent not terminated hereunder.

14.4 ALLOWABLE TERMINATION COSTS

14.4.1 If the Owner terminates the whole or any portion of the Work pursuant to Section 14.2, then the Owner shall only be liable to the Contractor for those costs reimbursable to the Contractor in accordance with Paragraph 14.4.2, plus a markup of ten percent (10%) for profit and overhead on the actual fully accounted costs specified under Paragraph 14.4.2; provided however, that if there is evidence that the Contractor would have sustained a loss on the entire Contract had it been completed, no profit or overhead shall be included or allowed hereunder for the Work performed and an appropriate adjustment shall be made reducing the amount of the settlement to reflect the indicated rate of loss. Under no circumstances shall the Contractor be entitled to any loss profit on the Work terminated pursuant to Section 14.2.

14.4.1.1 After receipt of a Notice of Termination, the Contractor shall submit to the Owner his termination Claim, in the form and with certification prescribed by the Owner. Such Claim shall be submitted promptly but in no event later than three (3) months from the effective date of termination, unless one or more extensions in writing are granted by the Owner upon request of the Contractor made in writing within such three (3) month period or authorized extension thereof. However, if the Owner determines that the facts justify such action, he may receive and evaluate any such termination Claim at any time after such three (3) month period or any extension thereof. Upon failure of the Contractor to submit his termination Claim within the time allowed, the Owner may determine, on the basis of information available to him, the amount, if any, due to the Contractor by reason of the termination and such termination shall be final and binding on the Contractor.

14.4.2 If the Owner terminates the whole or any portion of the Work pursuant to Section 14.2, the Owner shall pay the Contractor an amount for supplies, services, or property accepted by the Owner, and which is in accordance with the Contract Documents, in an amount as if the Contract had not been terminated. In addition, in such event, the Owner shall pay to Contractor an amount representing Contractor's actual cost, excluding any overhead and profit for the items and things specified in Subparagraph 14.5.1.6 and not heretofore paid for, appropriately adjusted for any saving of freight or other charges. Under no circumstances shall the Contractor be entitled to any loss profit on the Work terminated pursuant to Section 14.2.

14.4.2.1 The Contractor agrees that neither the Owner nor the Design Consultant will be liable for payments to Contractors or Subcontractors pursuant to Section 14.4.2 unless each contract and

subcontract contains termination provisions identical to those set forth in this Article 14. The Owner and the Design Consultant will not be liable to the Contractor or any of the Subcontractors for any costs associated with termination if the contract or subcontract of the party involved does not include the required termination language.

14.4.3 In arriving at any amount due the Contractor pursuant to Section 14.4, there shall be deducted the following:

- .1 All unliquidated advance or other payments on account theretofore made to the Contractor applicable to the terminated portion of the Contract;
- .2 Any Claim which the Owner may have against the Contractor;
- .3 Such amount as the Owner determines to be necessary to protect the Owner against loss because of outstanding or potential liens or claims; and
- .4 The agreed price for, or the proceeds of sale of, any materials, supplies or other things acquired by the Contractor sold, pursuant to the provisions of Subparagraph 14.5.1.7, and not otherwise recovered by or credited to the Owner, or returned for a refund by the Contractor.
- .5 All other amounts the Owner is entitled to withhold from the Contractor or charge to the Contractor pursuant to the Contract or as allowed by applicable law.

14.4.4 The total sum to be paid to the Contractor under Section 14.4 shall not exceed the Contract Sum as reduced by the amount of payments otherwise made or to be made for Work not terminated and as otherwise permitted by the Contract. Except for normal spoilage, and except to the extent that the Owner shall have otherwise expressly assumed the risk of loss, there shall be excluded from the amounts payable to the Contractor, as provided in Paragraph 14.4.2, the fair value, as determined by the Owner, of property which is destroyed, lost, stolen or damaged so as to become undeliverable to the Owner, or to a buyer pursuant to Subparagraph 14.5.1.7.

14.5 GENERAL TERMINATION PROVISIONS

14.5.1 After receipt of a Notice of termination from the Owner, pursuant to Section 14.2 or 14.3, and except as otherwise directed by the Owner, the Contractor shall:

- .1 Stop work under the Contract on the date and to the extent specified in the Notice of termination;
- .2 Place no further orders or subcontracts for materials, services or facilities, except as may be necessary for completion of such portion of the Work under the Contract as is not terminated;
- .3 Terminate all orders and subcontracts to the extent that they relate to the performance of the Work terminated by the Notice of termination;
- .4 At the option of the Owner, and in lieu of terminating such orders and subcontracts, assign to the Owner in the manner, at the times and to the extent directed by the Owner in writing, all of the rights in the such orders and subcontracts,
- .5 Settle all outstanding liabilities and all Claims arising out of such termination or orders and

subcontracts, with the approval or ratification of the Owner in writing, to the extent he may require, which approval or ratification shall be final for all the purposes of this Article;

- .6 Transfer title and deliver to the entity or entities designated by the Owner, in the manner, at the times and to the extent directed by the Owner to the extent specifically produced or specifically acquired by the Contractor for the performance of such portion of the Work as had been terminated, the following:
 - (1) The fabricated or unfabricated parts, Work in process, partially completed supplies and equipment, materials, parts, tools, dies, jigs and other fixtures, completed Work, supplies and other material produced as part of, or acquired in connection with the performance of, the Work terminated by the Notice of termination; and
 - (2) The completed or partially completed plans, drawings, information, releases, manuals and other property related to the Work and which, if the Contract had been completed, would have been required to be furnished to the Owner;
- .7 Use his best efforts to return for a refund or sell, in the manner, at the times, to the extent and at the price or prices directed or authorized by the Owner, any property of the types referred to in Subparagraph 14.5.1.6; provided, however, that the Contractor:
 - (1) Shall not be required to extend credit to any buyer, and
 - (2) May acquire any such property under the conditions prescribed by and at a price or prices approved by the Owner in writing; and provided further that the proceeds of any such transfer or disposition shall be applied in reduction of any payments to be made by the Owner to the Contractor under the Contract or shall otherwise be credited to the Contract Sum covered by the Contract or paid in such other manner as the Owner may direct;
- .8 Complete performance of such part of the Work as shall not have been terminated by the Notice of termination;
- .9 Take such action as may be necessary, or as the Owner may direct, for the protection and preservation of the property related to the Contract which is in the possession of the Contractor and in which the Owner has or may acquire an interest; and
- .10 Otherwise mitigate any damages Contractor claims to suffer as a result of a termination.

14.5.2 The Contractor shall, from the effective date of termination until the expiration of three (3) years after final settlement under the Contract, preserve and make available to the Owner, at all reasonable times at the office of the Contractor, but without direct charge to the Owner, all his books, records, documents and other evidence bearing on the costs and expenses of the Contractor under the Contract and relating to the Work terminated hereunder, or, to the extent approved by the Owner, photographs, micro-photographs or other authentic reproductions thereof.

14.5.3 If the termination, pursuant to Section 14.2, be partial, the Contractor may file with the Owner a Claim for an equitable adjustment of the price or prices specified in the Contract relating to the continued portion of the Contract (the portion not terminated by the Notice of termination), and such equitable adjustment as may be agreed upon shall be made in such price or prices. Any Claim by the Contractor for an equitable adjustment under this Paragraph must be asserted

within thirty (30) days from the effective date of the Notice of termination.

- 14.5.4 The Contractor shall refund to the Owner any amounts paid by the Owner to the Contractor in excess of costs reimbursable under Section 14.4.
- 14.5.5 The Contractor shall be entitled to only those damages and that relief from termination by the Owner as specifically provided in Article 14.

ARTICLE 15

DISPUTE RESOLUTION

15.1 INITIATING CLAIMS

- 15.1.1 Claims must be initiated by written Notice to the Owner and to the party against whom the Claim is made with a copy to the Design Consultant. The responsibility to substantiate Claims shall rest with the party making the Claim.
- 15.1.2 Nothing in the Contract shall be construed as meaning that the Owner's assessment of Liquidated Damages is a Claim as defined herein, or that the Owner has the burden of proof to assess Liquidated Damages. Should the Owner assess Liquidated Damages, the burden of proving that such damages should not have been assessed shall rest upon the Contractor.

15.2 RESOLUTION OF CLAIMS AND DISPUTES BETWEEN CONTRACTOR AND OWNER

- 15.2.1 Claims by Contractor against Owner and by Owner against Contractor, including those alleging an error or omission by the Design Consultant shall be subject to the process set forth in this Section 15.2. Such Claims shall be referred initially to the Design Consultant for a decision. A final decision by the Design Consultant, or the failure of the Design Consultant to issue a final decision shall be required as a condition precedent to mediation or litigation of all such Claims arising prior to the date final payment is due. The Design Consultant will initially decide disputes between Owner and Contractor.
- 15.2.2 The Design Consultant will review Claims by Contractor and Owner against each other and within twenty (20) days of the receipt of the written Claim and take one or more of the following actions:
 - .1 Request additional supporting data from the claimant or a response with supporting data from the other party;
 - .2 Reject the Claim in whole or in part;
 - .3 Approve the Claim;
 - .4 Suggest a compromise; or
 - .5 Advise the parties that the Design Consultant is unable to resolve the Claim if the Design Consultant lacks sufficient information to evaluate the merits of the Claim or if the Design Consultant concludes that it would be inappropriate for the Design Consultant to resolve the Claim.
- 15.2.3 In evaluating Claims made under this Section 15.2, the Design Consultant may, but shall not be

obligated to, consult with or seek information from either party or from persons with special knowledge or expertise who assist the Design Consultant in rendering a decision.

- 15.2.4 If the Design Consultant requests a party to provide a response to a Claim under this Section 15.2, or to furnish additional supporting data, such party shall respond, within ten (10) days after receipt of such request, and shall within such time period, either provide a response to the requested supporting data, advise the Design Consultant when the response or supporting data will be furnished, or advise the Design Consultant that no supporting data will be furnished. Upon receipt of the response or supporting data, if any, the Design Consultant will either reject or approve the Claim in whole or in part.
- 15.2.5 The Design Consultant will approve or reject Claims under this Section 15.2 by written decision, which shall state the reason thereof and which shall notify the parties of any change in the Contract Sum or Contract Time or both. The approval or rejection of a Claim by the Design Consultant under this Section 15.2 shall be final and binding on the parties but subject to mediation and litigation.
- 15.2.6 When a written decision of the Design Consultant under this Section 15.2 states that the decision is final but subject to mediation, then a demand for mediation of a Claim covered by such decision must be made within thirty (30) days after the date on which the party making the demand receives the final written decision. Any failure to demand mediation within said thirty (30) days' period shall result in the Design Consultant's decision becoming final and binding to all parties. Claims not resolved in mediation shall be subject to litigation if in accordance with the applicable statutes of limitation and repose.
- 15.2.7 Upon receipt of a Claim under Section 15.2 against the Contractor or at any time thereafter, the Design Consultant or the Owner may, but is not obligated to, notify the Surety, if any, of the nature and amount of the Claim. If the Claim relates to a possibility of a Contractor's default, the Design Consultant or the Owner may, but are not obligated to, notify the Surety and request the Surety's assistance in resolving the controversy.
- 15.2.8 If the Design Consultant deems that a Claim under this Section 15.2 is valid, the Design Consultant shall require all parties to the dispute to share the cost of the Design Consultant's review equitably. If the Design Consultant deems that a Claim under this Section 15.2 is invalid, the Design Consultant shall require the complaining party to bear the cost of the Design Consultant's review. In any event, the Design Consultant may require the complaining party to submit a deposit equivalent to the Design Consultant's hourly rate multiplied by the amount of time the Design Consultant estimates, in the Design Consultant sole discretion, that will be necessary to review the Claim. The Design Consultant shall return any unused portion of this initial deposit to the complaining party following the Design Consultant's completion of the Design Consultant's review of the Claim. Nothing in these procedures shall entitle the Design Consultant to compensation for additional services from the Owner that is not authorized pursuant to the terms and conditions of the Agreement for Design Consultant Services.

15.3 TIME LIMITS ON CLAIMS

- 15.3.1 Unless a shorter time is provided in the Contract Documents, Claims by Contractor or any party except Owner must be initiated within twenty (20) days after occurrence of the event giving rise to such Claim or within twenty (20) days after the claimant first recognizes the condition giving rise to the Claim, whichever is later. Claims against the Owner shall be initiated in strict conformance with the Contract Documents. Nothing in these procedures shall extend the period within or the manner in which Claims against the Owner must be submitted. Claims must be

initiated by written Notice to the Owner and written notice to the other party and to the Design Consultant. Any Claim against the Owner that is not initiated within the applicable time period is waived. Claims by Owner may be made at any time within the applicable statute of limitations and repose.

15.4 CONTINUING CONTRACT PERFORMANCE

15.4.1 Pending final resolution of a Claim, the Contractor shall proceed diligently with the performance of the Contract, unless instructed otherwise in writing by the Owner.

15.5 MEDIATION

15.5.1 As required by N.C.G.S 143-128 (f1), any Claim as defined herein, which exceeds fifteen thousand dollars(\$15,000.00), and which concerns a party involved in the Project, including the Owner, Contractor, Design Consultant, any construction manager, Separate Contractors, or first and lower tier Subcontractors and which arise out of the Contract or the construction process, except those waived Claims shall, be subject to mediation as a condition precedent to the institution of legal proceedings by any party, except that any party may institute legal proceedings or perfect any mechanic's or materialmen's lien in order to meet any applicable statute of limitations or similar deadline prior to engaging in mediation.

15.5.2 The parties shall endeavor to resolve their Claims under this Section 15.5 by mediation which, unless the parties mutually agree otherwise, shall be in accordance with the rules established by the Owner.

15.5.3 The parties shall share cost of the mediation equally except that if the Owner is a party to the dispute, the Owner shall pay at least one third of the cost of the mediation.

15.5.4 The mediation shall be held in a place where the Project is located, unless another location is mutually agreed upon.

15.5.5 Agreements reached in mediation shall be enforceable as settlement agreements in any court having jurisdiction thereof.

END OF GENERAL CONDITIONS

SECTION 00 73 00

SUPPLEMENTARY CONDITIONS

PART 1 GENERAL

1.1 SUMMARY

- A. The following supplements modify, change, delete from or add to the Owner's "General Conditions of the Contract for Construction". All unaltered provisions shall remain in effect.

PART 2 PRODUCTS (NOT USED)

PART 3 EXECUTION (NOT USED)

END OF SECTION

SECTION SC

SUPPLEMENTARY CONDITIONS

THIS SECTION TO BE COMPLETED BY POST BID ADDENDUM

GENERAL CONDITIONS

Document GC, GENERAL CONDITIONS OF THE CONTRACT FOR CONSTRUCTION, constitutes the General Conditions of this Contract, and is hereinafter called "General Conditions." The General Conditions are further revised and supplemented by the provisions of these Supplementary Conditions. The General Conditions and the Supplementary Conditions are applicable to all of the Work under this contract and shall apply to the Contractor and all Subcontractors and Sub-subcontractors.

SUPPLEMENTS:

The following supplements modify, change, delete, or add to the General Conditions. Where any article of the General Conditions is modified or any paragraph deleted, subparagraph or clause thereof is modified, or deleted by these supplements, the unaltered provisions of such article, paragraph, subparagraph or clause shall remain in effect. If there is a discrepancy between the General Conditions and these Supplementary Conditions, the Supplementary Conditions shall control.

ARTICLE 1 - CONTRACT DOCUMENTS

ADD THE FOLLOWING TO 1.3.1:

1.3.1.1 The Contractor will be furnished with one set drawings and specifications for free.

ARTICLE 2 - ARCHITECT

ADD THE FOLLOWING TO PARAGRAPH 2.1:

Design Consultant:

REI Engineers, Inc.
9121 Anson Way, Suite 100
Raleigh, NC 27615

ARTICLE 4 – CONTRACTOR

ADD THE FOLLOWING AFTER THE FIRST SENTENCE OF PARAGRAPH 4.24:

The Owner's policies are available for review at www. [REDACTED].

ARTICLE 7 – MISCELLANEOUS PROVISIONS

ADD THE FOLLOWING TO THE END OF 7.1.1

The Contractor and Owner agree that Orange County, North Carolina shall be the proper venue for any litigation arising out of this Agreement.

ARTICLE 8 - TIME

ADD THE FOLLOWING TO PARAGRAPH 8.2:

8.2.4 The schedule below contains certain specific dates in addition to date of Notice to Proceed and Time for Completion. These dates shall be adhered to and are the last acceptable dates unless modified by mutual agreement between the Contractor and the Owner. All dates indicate midnight unless otherwise stipulated. The only exceptions to this schedule are defined in the General Conditions and Supplementary Conditions under Paragraph 8.3 DELAYS AND EXTENSIONS OF TIME.

Notice of Intent to Award – Insert Date
Return of Owner Contractor Agreement by Contractor – Insert Date
Notice to Proceed – Insert Date
Substantial Completion – Insert Date
Completion of all Commissioning – Insert Date
Final Completion – Insert Date

8.2.4.1 The Owner reserves the right to withhold the issuance of Notice to Proceed by up to forty-five 45 days. For each day that Notice to Proceed is withheld pursuant to this Subparagraph, the dates established for Substantial Completion and Final Completion shall be adjusted. The contractor shall not be entitled to additional compensation if the owner withholds the issuance of Notice to Proceed pursuant to this Subparagraph.

ADD THE FOLLOWING TO THE END OF THE FIRST PARAGRAPH IN 8.3.4.2.3:

The Parties agree that the weather station applicable to this Project shall be the one located at _____.

ARTICLE 9 - PAYMENTS AND COMPLETION

ADD THE FOLLOWING TO PARAGRAPH 9.6:

9.6.3 Additional services and dispute resolution services by the Design Consultant shall be paid by the Contractor at the rate 155.00 per hour.

ADD THE FOLLOWING TO PARAGRAPH 9.10:

9.10.1.1 Substantial Completion Liquidated Damages shall be the sum of five hundred dollars 500.00 per calendar day, and this amount shall be assessed in accordance with Subparagraph 9.10.1 of the General Conditions.

9.10.2.1 Final Completion Liquidated Damages shall be the sum of five hundred dollars 500.00 per calendar day, and this amount shall be assessed in accordance with Subparagraph 9.10.2 of the General Conditions.

ARTICLE 15 – DISPUTE RESOLUTION

ADD THE FOLLOWING NEW PARAGRAPH 15.6:

15.6 The Owner's Dispute Resolution Policy required by N.C.G.S. § 143-128 f1 is contained in Policy www._____.com. The Dispute Resolution Policy is also included in the bid and contract documents.

END OF SUPPLEMENTARY CONDITIONS

SECTION 01 11 00
SUMMARY OF WORK

PART 1 GENERAL

1.1 WORK COVERED BY CONTRACT DOCUMENTS

- A. Project Name: New Hope Elementary School Building Enclosure Maintenance & Repair
- B. Project Address: 1900 New Hope Church Road, Chapel Hill, North Carolina 27514
- C. Owner: Orange County Schools
- D. Engineer: The Contract Documents, dated 04-10-2024, were prepared by REI Engineers, Inc.
- E. This work includes the provision of labor, material, equipment, supervision and administration to integrate the work outlined in these specifications into the total building system such that no leakage into the system occurs. In general, the scope of work in the Base Bid includes:
 - 1. Exterior Wall Restoration:
 - a. Replace elastomeric joint sealants as indicated in Contract Drawings.
 - b. Properly clean exterior walls and windows.
 - c. Provide exterior downspouts, capping existing interior routed downspouts within wall, and tie into existing below-grade stormwater system.
 - d. Repoint masonry mortar joints in accordance with Unit Prices and Quantity Allowances.
 - e. Replace damaged/ broken concrete masonry unit (CMU) veneer units in accordance with Unit Prices and Quantity Allowances.
 - f. Clean, prime, and paint exposed portions of steel lintels in accordance with Unit Prices and Quantity Allowances.
 - g. Replace concrete slab-on-grade sidewalks where impacted by below grade work in accordance with Unit Prices and Quantity Allowances.
 - h. Clean, prime, and paint exposed portions of steel lintels in accordance with Unit Prices and Quantity Allowances.
 - i. Water test all exterior building storm drainage, clear cloggs and make free flowing all below-grade drain lines downstream from downspout tie-ins to collection boxes.
 - 2. Below Grade Waterproofing:
 - a. Prepare wall substrate to receive waterproofing system patch whrere wall is repaired during downspout work.

- b. Provide below grade waterproofing system target patch, including protection/ drainage board (if present).
 - c. Backfill excavated area sloped away from building at minimum 2% slope.
 - d. Replace surface improvements and plantings to match existing types.
- F. Provide electrical, plumbing, mechanical, and other related trade work necessary to facilitate project operations. Relocate or raise conduit, HVAC equipment, curbs, and/or plumbing necessary to comply with the requirements of these documents and conform to the requirements of the State Building Code.
 - 1. Conduct construction operations so that heat, air conditioning, ventilation, electrical, telephone, gas, water, sanitary, storm sewer, and any other service required for the building operations are maintained at all times during normal working hours. Any shutdowns or interruptions shall be coordinated with and approved by the owner.
- G. General requirements and specific recommendations of the material manufacturers are included as part of these specifications. The manufacturers' specifications are the minimum standards required for the completed systems. Where specific items listed herein improve the standards required by the manufacturers, they take precedence where their compliance does not affect the manufacturers' guarantee or warranty provisions.
- H. Act as the Project Expeditor and coordinate work and schedules of others hired. Execution of work within allotted time as indicated is the sole responsibility of the bidding contractor.

1.2 ASBESTOS CONTAINING ROOFING MATERIALS (ACRM):

- A. Sample Testing Results:
 - 1. No materials were sampled or tested for asbestos.
- B. It is the intention of these specifications that no asbestos bearing materials be incorporated into the work. In the event the contractor determines unanticipated asbestos bearing materials present in the building components, stop work in the affected area, notify the Engineer and Owner, and provide temporary protection as required. Costs incurred due to the presence of hidden or unanticipated asbestos bearing materials will be authorized by Change Order to this contract.

1.3 REFERENCE STANDARDS

- A. CSI/CSC MF - Masterformat; 2016.

1.4 CONTRACT

- A. Project constructed under a single prime general construction contract between Owner and Contractor.

1.5 WORK UNDER OTHER CONTRACTS

- A. Separate Contract: Owner may award a separate contract for performance of certain construction operations at Project site.
 - 1. None

- B. Cooperate with separate contractors so work on those contracts are carried out smoothly without interfering with or delaying Work under this Contract.

1.6 SPECIFICATION FORMATS AND CONVENTIONS

- A. Specification Format: The Specifications are organized into Divisions and Sections using the 49-division format and CSI/CSC MF numbering system.
 - 1. Section Identification: The Specifications use section numbers and titles to cross-reference Contract Documents. Sections in the Project Manual are in numeric sequence; however, the sequence is incomplete.
- B. Specification Content: The Specifications use certain conventions for the style of language and the intended meaning of certain terms, words, and phrases when used in particular situations. These conventions are as follows:
 - 1. Abbreviated Language: Language used in the Specifications and other Contract Documents is abbreviated. Interpret words and meanings as appropriate. Infer words implied, but not stated, as the sense requires. Interpret singular words as plural and plural words as singular where applicable as the context of the Contract Documents indicates.
 - 2. Imperative mood and streamlined language are generally used in the Specifications. Perform requirements expressed in the imperative mood. Occasionally, the indicative or subjunctive mood may be used in the Section Text for clarity to describe responsibilities that must be fulfilled indirectly by Contractor or by others when so noted.
 - a. The words "shall" "shall be" or "shall comply with" depending on the context, are implied where a colon (:) is used within a sentence or phrase.

END OF SECTION

SECTION 01 14 00

WORK RESTRICTIONS

PART 1 GENERAL

1.1 SUMMARY

- A. Section Includes:
 - 1. Administrative and procedural requirements for work sequence, work restrictions, occupancy requirements and use of premises.

1.2 RELATED DOCUMENTS

- A. Drawings and general provisions of the Contract, including General and Supplementary Conditions and Specification Sections, apply to this Section.

1.3 SUBMITTALS

- A. Background Checks: Provide background checks for employees anticipated to work on-site during the project.

1.4 WORK SEQUENCE

- A. Construct Work in phases to accommodate the Owner's use; if applicable, of the premises during the construction period; coordinate the construction schedule and operations with the Owner and Engineer.
 - 1. EC Classrooms, Canopies, and Outdoor Activity/Operations areas are priority for Summer Construction.
 - 2. Certain areas of the building facade cannot be accessed during school hours, coordinate with the School.
- B. Construct the Work in phases to provide for public convenience. Do not close off public use of facility until completion of one phase of construction provides alternative usage.
- C. Schedule construction in such a manner that once work has commenced on one facility, the work force to remain at that facility continuously each workday through final completion at that facility.

1.5 WORK RESTRICTIONS

- A. K-12 School Work Restrictions:
 - 1. Work hours generally performed during normal business hours.
 - 2. Coordinate work schedule with School's testing and special events schedule. Contractor may not be allowed on-site during certain testing days/events.

1.6 OCCUPANCY REQUIREMENTS

- A. Owner Occupancy:

1. Owner occupies the premises during construction to conduct his normal operations. Cooperate with Owner in construction operations to minimize conflict and to facilitate Owner usage.
2. Conduct operations as to ensure the least inconvenience and the greatest amount of safety and security for the Owner, building occupants, and the general public.
3. Control noise from operations so that building occupants are not affected.

1.7 SECURITY

- A. Restrict the access of persons entering upon the Owner's property in connection with the work to the Contractor's Entrance and to the site of the work.
- B. Maintain an accurate record of the names and identification of visitors entering upon the Owner's property in connection with the work of this contract, including times of entering and times of leaving, and submit a copy of the record to the Owner weekly.
- C. Background Checks: No persons/personnel allowed on site without the following background checks: Nationwide, Sex Offender check, Social Security Number check. Provide this information to the Engineer/Owner 5 business days prior to the scheduled access for each person. Owner's decision on acceptability of personnel. Each person is required to wear a badge with name, photograph, and company name. Ensure background checks for persons are submitted to Owner and those persons denied access are not allowed on-site.

1.8 USE OF SITE

- A. Limit use of premises and confine construction operations to work in areas indicated and approved by Engineer and Owner. Do not disturb portions of site beyond areas in which the Work is indicated.
 1. Keep driveways and entrances serving premises clear and available to Owner, Owner's employees, and emergency vehicles. Do not use these areas for parking or storage of materials.
 - a. Schedule deliveries to minimize use of driveways and entrances.
 - b. Schedule deliveries to minimize space and time requirements for storage of materials and equipment on-site.
 - c. Schedule deliveries to avoid student pick up and drop off times.
 2. Perform Work in a way that does not restrict parking lots or other locations outside the work area from the facility. Maintain safe access for vehicles.
 3. Move stored materials and equipment that interfere with operations of the Owner.
 4. Protect surface improvements including pavements, curbs, sidewalks, lawn and landscaped areas, utilities, etc.
 5. Repair to the Owner and Engineer's satisfaction, or to restore to condition at the time of award of Contract, or to make restitution acceptable to the Owner, damages to surface improvements resulting from, or attributable to, the work operation.

- a. Repair damaged concrete by replacing full sections of concrete between control/expansion joints.
 - b. Fill ruts in grass areas and grade to original conditions. Provide grass seed and straw.
 - c. Replace disturbed landscaping in mulched or natural areas.
- B. Transportation Facilities
- 1. Truck and equipment access:
 - a. Avoid traffic conflict with vehicles of the Owner's employees and customers and avoid over-loading of street and driveways elsewhere on the Owner's property, limit the access of trucks and equipment to the designated areas.
 - b. Provide adequate protection for curbs and sidewalks over which trucks and equipment pass to reach the job site.
 - 2. Contractor's vehicles:
 - a. Require contractor's vehicles, vehicles belonging to employees of the contractor, and other vehicles entering the Owner's property in performance of the work the contract, to use only the designated access route.
 - b. Do not permit such vehicles to park on street or other area of the Owner's property except in the designated area.

1.9 USE OF BUILDING

- A. Maintain building in a weathertight condition throughout construction period.
- B. Take precaution against injuries to persons or damage to property.
- C. Protect building, its contents, and its occupants during construction period.
- D. Do not overload or permit the structure to be loaded with such weights that endanger its safety or to cause excessive deflection. Equally distribute materials placed on the roof.
- E. Properly secure materials or equipment placed on roof to prevent blow off during wind events. Ensure materials or equipment on roof does not interfere with roof drainage.
- F. Repair to the Owner and Engineer's satisfaction, or to restore to condition at the time of award of Contract, or to make restitution acceptable to the Owner, damages to the building and its contents resulting from, or attributable to, the work operation.
- G. Indoor Air Quality:
 - 1. Coordinate with the facility personnel to identify the area where roof work is performed daily and what HVAC equipment and personnel in the building may be affected by the work.
 - 2. Work with facility personnel to prevent odors or fumes from entering the building or where found to not be practical due to the work area, HVAC equipment limitations or other reasons; coordinate with facility personnel to have occupants relocated to an area of the building not affected by the work.

3. When possible to safely shut down and seal HVAC equipment; as determined by the facility personnel, coordinate with facility personnel to have mechanical units affected by the planned work area and air intakes properly closed and sealed. After closing of mechanical units and air intakes, cover units and intakes with 6-mil polyethylene sheeting taped secure. Remove polyethylene sheeting before coordinating restart of units and intakes.
4. Provide box carriage fans on rooftop during roof application to move and circulate air away from intakes and units.
5. Where HVAC equipment is required to remain operational during roof work, coordinate with facility personnel to cover air intakes with charcoal filters prior to beginning work.
6. When starting roof work using materials which have odors or emit fumes, communicate with facility personnel within the building in the area of the work to determine if fumes or odors are being experienced. If fumes or odors are experienced, stop work until the cause is determined and remediated or occupants can be moved to an area not affected by the work.

1.10 NORTH CAROLINA K-12 SCHOOL POLICIES

- A. Tobacco Policy: The Owner has adopted a Tobacco Free Policy which applies to school property. This is a total ban on tobacco products including cigarettes, cigars, pipes, chewing tobacco, snuff, etc. Contractor is responsible for employee's actions while they are on school property. Failure to follow this policy constitutes a breach of contract and said contract may be terminated without penalty to the school system.
- B. Weapons and Explosives Policy: Excluding law enforcement, persons are prohibited from possessing, carrying, using or threatening to use, or encouraging another person to possess, carry, use or threaten to use, weapons or explosives on school property or while attending curricular or extracurricular activities sponsored by the school. This policy applies to weapons or explosives carried openly or concealed. For purposes of this policy, a weapon includes, but is not limited to gun, rifle, pistol or other firearm; or BB gun, stun gun, air rifle, air pistol, bowie knife, dirk, dagger, slingshot, leaded cane, switchblade knife, blackjack, metallic knuckles, razors and razor blades except solely for personal shaving, fireworks, or sharp-pointed or edged instrument except instructional supplies, unaltered nail files and clips and tools used solely for preparation of food, instruction and/or maintenance on educational property. For purposes of this policy, an explosive includes, but is not limited to and dynamite cartridge, bomb, mine or powerful explosive as defined in N.C. G.S. 14-284.1. For purposes of this policy, school property is school building or bus, school campus, grounds, recreational area, athletic field, or other property owned, used or operated by The Board of Education. This policy does not apply to: 1 a weapon or explosive used solely for educational or school sanctioned ceremonial purposes, or used in a school approved program conducted under the supervision of an adult whose supervision has been approved by the school authority, or 2 firefighters, emergency personnel, North Carolina Forest Service personnel, and private police employed by the School Board, when acting in the discharge of their official duties.

- C. Criminal Record Investigation: When requested by Owner, obtain a county, state and national criminal history covering the past ten years on contractor applicant or contractor employee, hereafter called prospective worker, providing services to Owner. As a minimum, criminal information sources include State and National access to the SBI/DCI Criminal History Record Information for the prospective worker's residence s , past ten years and fingerprints forwarded to the Federal Bureau of Investigation for the search. Previously conducted criminal histories more than one year old are required to be updated. Provide a Criminal Histories Report two weeks prior to arriving "on-site" and update report monthly for new hires. Prospective workers who refuse to provide fingerprints and/or consent to the Criminal Background checks or who have been convicted of sexual deviance, sexual crime, domestic violence, violence against another human being, larceny, alcohol/drug trafficking, alcohol/drug abuse or other disqualifying offense as determined by the Owner, are not be allowed on the property.
- D. Conduct Policy: The conduct of contractor employees to be exemplary; profanity, drinking, lewd or suggestive comments or gestures or other acts of this nature are not tolerated.
- E. Drug Free Policy: Owner conforms to a drug free policy. Contractor employee must be tested upon request of Owner and results provided to Owner. If the employee is found to have been under the influence or using drugs, it constitutes a breach of contract and said contract may be terminated without penalty to the school system.
- F. Dress Code Policy: Shirts and shoes are required, as well as long pants. Identification of employees, vehicles, uniforms, etc. is required when indicated.

END OF SECTION

SECTION 01 21 00

ALLOWANCES

PART 1 GENERAL

1.1 SUMMARY

A. Section Includes:

1. Administrative and procedural requirements governing allowances.

1.2 RELATED DOCUMENTS

A. Drawings and general provisions of the Contract, including General and Supplementary Conditions and Specification Sections apply to this Section, including but not limited to:

1. Section 03 01 30.71 - Rehabilitation of Cast-in-Place Concrete
2. Section 04 05 24 - Masonry Repointing

1.3 ABBREVIATIONS

A. Abbreviations for typical units of measurement:

1. Square Foot (SF)
2. Square Yard (SY)
3. Cubic Foot (CF)
4. Board Foot (BF)
5. Linear Foot (LF)
6. Each (EA)
7. Tonnage (TON)

1.4 CONTINGENCY ALLOWANCE

- A. Include the specified contingency allowance in the base bid.
- B. Credit unused portion remaining at the completion of the contract back to the Owner.
- C. The Owner reserves the right to modify the contingency allowance prior to award of Contract.

1.5 QUANTITY ALLOWANCES

- A. Include the specified quantity allowances in the base bid. Use the unit price submitted on the Bid Form to compute the quantity allowances. The quantities indicated on the Bid Form are estimated quantities only for the purpose of comparing bids. Compensation for the unit price bid made for the exact quantity of work performed under the unit price item. Deductive amounts of unit price work included in the Contract Sum are calculated at 100% of the quoted add unit price.

PART 2 PRODUCTS (NOT USED)

PART 3 EXECUTION

3.1 SCHEDULE OF ALLOWANCES

- A. Contingency Allowance: Include a \$35,000.00 contingency allowance in the base bid.
- B. Quantity Allowances:
 - 1. Repoint 12,000 LF of Deteriorated Mortar Joints. Refer to Section 04 05 24 - Masonry Repointing.
 - 2. Replace 150 EA of Deteriorated Concrete Masonry Veneer Units. Refer to Section 04 20 00 "Unit Masonry".
 - 3. Replace 250 SF of 4 inch Sidewalk. Refer to Section 32 05 23 "Cement and Concrete for Exterior Improvements". Include the related cost for furnishing, mobilizing, forming, and pouring of material. Include the related cost for hauling and disposal of all existing material.

END OF SECTION

SECTION 01 22 00

UNIT PRICES

PART 1 GENERAL

1.1 SUMMARY

A. Section Includes:

1. Administrative and procedural requirements for unit prices.

1.2 RELATED DOCUMENTS

A. Drawings and general provisions of the Contract, including General and Supplementary Conditions and Specification Sections apply to this Section, including but not limited to:

1. Section 04 05 24 - Masonry Repointing

1.3 DEFINITION

A. Unit price is an amount proposed by Bidders, stated on the Bid Form, as a price per unit of measurement for materials or services added to or deducted from the Contract Sum by appropriate modification, if estimated quantities of Work required by the Contract Documents are increased or decreased.

1.4 ABBREVIATIONS

A. Abbreviations for typical units of measurement:

1. Square Foot (SF)
2. Square Yard (SY)
3. Cubic Foot (CF)
4. Board Foot (BF)
5. Linear Foot (LF)
6. Each (EA)
7. Tonnage (TON)

1.5 UNIT PRICE MEASUREMENT

A. Prior to performing work under a unit price as specified herein, notify the Engineer to allow for measurement of the actual quantities of work. Work performed under these items without prior approval and measurement is at the Contractor's expense.

B. Maintain a daily log including visual documentation (i.e. digital photographs) showing dates, location and exact quantities of unit price work.

C. Owner and Engineer reserve the right to reject Contractor's measurement of work-in-place that involves use of established unit prices and to have this work measured, at Owner's expense, by an independent party.

1.6 UNIT PRICE PAYMENT

- A. Include in unit prices costs associated with performing the unit price work including but not limited to labor, material, equipment, insurance, applicable taxes, overhead and profit, bonds, etc.

1.7 UNIT PRICE PERFORMANCE

- A. Install unit price work in accordance with the applicable specification sections and Contract Drawings.

PART 2 PRODUCTS (NOT USED)

PART 3 EXECUTION

3.1 SCHEDULE OF UNIT PRICES

- A. Provide a unit price for:
 - 1. Repoint Deteriorated Mortar Joint. Unit of Measurement: Linear Foot (LF). Refer to Section 04 05 24 - Masonry Repointing.
 - 2. Replace Deteriorated Concrete Masonry Veneer Units. Unit of Measurement: Each (EA). Refer to Section 04 20 00 - Unit Masonry.
 - 3. Provide 4 inch Sidewalk. Unit of Measurement: Square Foot (SF). Refer to Section 32 05 23 - Cement and Concrete for Exterior Improvements. Include the related cost for furnishing, mobilizing, forming, and pouring of material. Include the related cost for hauling and disposal of all existing material.

END OF SECTION

SECTION 01 23 00

ALTERNATES

PART 1 GENERAL

1.1 SUMMARY

A. Section Includes:

1. Administrative and procedural requirements for alternates.

1.2 RELATED DOCUMENTS

A. Drawings and general provisions of the Contract, including General and Supplementary Conditions and Specification Sections apply to this Section.

1.3 DEFINITIONS

A. Alternate: An amount proposed by bidders and stated on the Bid Form for certain work defined in the Bidding Requirements that may be added to or deducted from the Base Bid amount if Owner decides to accept a corresponding change either in the amount of construction or in the products, materials, equipment, systems or installation methods described in the Contract Documents.

1.4 ALTERNATES

A. Indicate on the Bid Form whether the alternate bid amount is to added to or deducted from the base bid in the event the alternate bid is accepted.

B. The Owner reserves the right to accept or reject any or all of the alternate bids.

C. Responsible for determining to his own satisfaction and for his own purposes the limits and extent of the work affected by the alternate bids and to make proper allowance therefore in the submission of alternate bid.

D. Include the cost of each alternate bid as specified in the technical specification sections and as described on the drawings. Perform work required by the alternate bids in accordance with applicable specifications and drawings of the trade section affected.

E. The cost or credit for each alternate is the net addition to or deduction from the Contract Sum to incorporate selected alternates into the Work. No other adjustments are made to the Contract Sum.

F. The Owner reserves the right to delay the acceptance of the alternate bids during the bid holding period prior to accepting the contract without a change in the dollar amount of the alternate bids.

PART 2 PRODUCTS (NOT USED)

PART 3 EXECUTION

3.1 SCHEDULE OF ALTERNATES

- A. Alternate No. 1: Replace glazing sealant at all exterior windows/storefronts.

END OF SECTION

SECTION 01 25 00

SUBSTITUTION PROCEDURES

PART 1 GENERAL

1.1 SUMMARY

A. Section Includes:

1. This Section specifies administrative and procedural requirements for handling requests for substitutions after award of Contract.

1.2 RELATED DOCUMENTS

A. Drawings and general provisions of the Contract, including General and Supplementary Conditions and Specification Sections apply to this Section.

1.3 DEFINITIONS

A. Substitutions: Requests for changes in products, materials, and equipment, of construction required by Contract Documents proposed by the Contractor are considered requests for "substitutions". The following are not considered substitutions:

1. Revisions to Contract Documents requested by the Owner or Engineer.
2. Specified options of products and construction methods included in Contract Documents.
3. Determination of and compliance with governing regulations and orders issued by governing authorities.

1.4 SUBMITTALS

A. Submit requests for acceptance of equivalent items in writing to the Engineer during the submittal process. No substitutions considered after acceptance of project submittals.

B. Substitutions after award are considered solely for convenience and approved by Change Order in form of credit to the Owner. Bear additional costs related to making the substituted material or system work including additional engineering, material or system modifications, and time considerations relating to material or system installation requirements.

C. Provide information sufficient for the Engineer to make a determination of equivalent items. Engineer's determination of the equivalency of a product is final. The Engineer reserves the right to request information or documentation for evaluation including but not limited to the following:

1. Provide a letter describing in detail proposed changes, substitutions, or deviations from the project or manufacturer's specifications.
2. A written explanation of why substitutions should be considered is required.
3. Statement indicating why specified product cannot be provided.
4. Coordination of information, including a list of modifications needed to other parts of the work necessary to accommodate proposed substitution.

5. Product data including drawings, descriptions, and fabrication/installation procedures.
6. Samples where applicable.
7. Material test reports from a qualified testing agency indicating the interpreting test results for compliance with requirements.
8. Contractor's certification that proposed substitution complies with requirements in the contract documents and is appropriate for applications indicated.
9. Contractor's waiver of rights to additional payment or time that may subsequently become necessary because of failure of proposed substitution to produce indicated results.
10. If requesting product substitution after bid award, provide cost information including proposal of change in the contract sum.

END OF SECTION

SECTION 01 26 00

CONTRACT MODIFICATION PROCEDURES

PART 1 GENERAL

1.1 SUMMARY

- A. Section Includes:
 - 1. Administrative and procedural requirements for handling and processing Contract modifications.

1.2 RELATED DOCUMENTS

- A. Drawings and general provisions of the Contract, including General and Supplementary Conditions and Specification Sections apply to this Section.

1.3 REFERENCE STANDARDS

- A. AIA G701 - Change Order; 2017.
- B. AIA G710 - Architect's Supplemental Instructions; 2017.
- C. AIA G714 - Construction Change Directive; 2017.

1.4 PROPOSAL REQUESTS

- A. Owner-Initiated Proposal Requests: A detailed description of proposed changes in the Work that may require adjustment to the Contract Sum or the Contract Time will be issued by the Engineer along with supplemental or revised Drawings and Specifications.
 - 1. Proposal Requests issued by Engineer are for information only. Do not consider them instructions either to stop work in progress or to execute the proposed change.
 - 2. Within 5 days after receipt of Proposal Request, submit a quotation estimating cost adjustments to the Contract Sum and the Contract Time necessary to execute the change.
 - a. Include a list of quantities of products required or eliminated and unit costs, with total amount of purchases and credits. If requested, furnish survey data to substantiate quantities.
 - b. Indicate applicable taxes, delivery charges, equipment rental, and amounts of trade discounts.
 - c. Include costs of labor and supervision directly attributable to the change.
 - d. Include an updated Construction Schedule that indicates the effect of the change, including, but not limited to, changes in activity duration, start and finish times, and activity relationship. Use available total float before requesting an extension of the Contract Time.
- B. Contractor-Initiated Proposals: If latent or unforeseen conditions require modifications to the Contract, propose changes by submitting a request for a change to Engineer.

1. Include a statement outlining reasons for the change and the effect of the change on the Work. Provide a description of the proposed change. Indicate the effect of the proposed change on the Contract Sum and the Contract Time.
 2. Include a list of quantities of products required or eliminated and unit costs, with total amount of purchases and credits. If requested, furnish survey data to substantiate quantities.
 3. Indicate applicable taxes, delivery charges, equipment rental, and amounts of trade discounts.
 4. Include costs of labor and supervision directly attributable to the change.
 5. Include an updated Construction Schedule that indicates the effect of the change, including, but not limited to, changes in activity duration, start and finish times, and activity relationship. Use available total float before requesting an extension of the Contract Time.
 6. Comply with requirements in Division 1 if the proposed change requires substitution of one product or system for product or system specified.
- C. Proposal Request Approval:
1. If sufficient contingency allowance funds remain, written approval will be provided by the Engineer in the form of an Allowance Authorization signed by the Engineer, Contractor and Owner.
 2. If contingency allowance funds are not available; upon approval by Owner, written approval will be provided by the Engineer in the form of a Change Order as provided in the Conditions of the Contract.
 - a. Form of Change Order: AIA G701.
 - b. Do not commence work or purchase materials for such change orders until written approval is received in the form of an executed Allowance Authorization or Change Order.
 - c. An executed Change Order is the only legal document which can change the Contract Sum or Time.

1.5 SUPPLEMENTAL INSTRUCTIONS

- A. Supplemental instructions authorizing minor changes in the Work, not involving an adjustment to the Contract Sum or Contract Time, will be issued by the Engineer on AIA G710.

1.6 CONSTRUCTION CHANGE DIRECTIVE

- A. Construction Change Directive: When the Owner and Contractor are not in total agreement on the terms of a Proposal Request; the Engineer may issue a Construction Change Directive on AIA G714, instructing the Contractor to proceed with a change in the Work, for subsequent inclusion in a Change Order.
1. The Construction Change Directive will contain a description of the change in the Work and designate the method followed to determine the change in the Contract Sum or Contract Time.

2. Submit unit costs, equipment rates and labor rates as requested by the Engineer and agree upon submitted rates before the work progresses unless directed to proceed in the absence of an agreement or in an emergency.
- B. Documentation: Maintain detailed records on a time and material basis of work required by the Construction Change Directive. Provide a copy of those records to the Engineer.
1. After completion of the change, submit an itemized account and supporting data necessary to substantiate cost and time adjustments to the Contract.

END OF SECTION

SECTION 01 29 00

PAYMENT PROCEDURES

PART 1 GENERAL

1.1 SUMMARY

- A. Section Includes:
 - 1. Administrative and procedural requirements necessary to prepare and process Applications for Payment.

1.2 RELATED DOCUMENTS

- A. Drawings and general provisions of the Contract, including General and Supplementary Conditions and Specification Sections apply to this Section.

1.3 DEFINITIONS

- A. Schedule of Values: A statement furnished by Contractor allocating portions of the Contract Sum to various portions of the Work and used as the basis for reviewing Contractor's Applications for Payment.

1.4 REFERENCE STANDARDS

- A. AIA G702 - Application and Certificate for Payment; 1992.
- B. AIA G703 - Continuation Sheet; 1992.
- C. AIA G706A - Contractor's Affidavit of Release of Liens; 1994.
- D. AIA G707 - Consent of Surety to Final Payment; 1994.

1.5 SUBMITTALS

- A. Sample Application for Payment Cover on AIA G702 .
- B. Schedule of Values: A schedule of values on AIA G703 Continuation Sheet consisting of a detailed breakdown of the Contract amount showing separate figures for labor and materials. The work listed under the various sections and subsections of the Specifications serve as the format for preparation.

1.6 SCHEDULE OF VALUES

- A. Coordination: Coordinate preparation of the Schedule of Values with preparation of Submittals.
 - 1. Correlate line items in the Schedule of Values with other required administrative forms and schedules, including the following:
 - a. Application for Payment Forms with Continuation Sheets
 - b. Submittals Schedule
 - c. Contractor's Construction Schedule

2. Submit the Schedule of Values to Engineer along with Submittals.
 3. Sub schedules: Where the Work is separated into phases requiring separately phased payments, provide sub schedules showing values correlated with each phase of payment.
- B. Format and Content: Provide one line item for labor and one line item for material for each Specification Section.
1. Identification: Include the following Project identification on the Schedule of Values:
 - a. Application for Payment Number.
 - b. Application for Payment Date.
 - c. Engineer's project number.
 - d. Period to for Schedule of Values.
 2. Provide a breakdown of the Contract Sum in enough detail to facilitate continued evaluation of Applications for Payment and progress reports. Coordinate with the Project Manual table of contents.
 3. Provide several line items for principal subcontract amounts, where appropriate.
 4. Round amounts to nearest whole dollar; total to equal the Contract Sum.
 5. Provide a separate line item in the Schedule of Values for each part of the Work where Applications for Payment may include materials or equipment purchased or fabricated and stored, but not yet installed.
 6. Differentiate between items stored on-site and items stored off-site. If specified, include evidence of insurance or bonded warehousing.
 7. Provide separate line items in the Schedule of Values for initial cost of materials, for each subsequent stage of completion, and for total installed value of that part of the Work.
 8. Allowances: Provide a separate line item in the Schedule of Values for each allowance. Show line-item value of unit-cost allowances, as a product of the unit cost, multiplied by measured quantity. Use information indicated in the Contract Documents to determine quantities.
 9. Complete each item in the Schedule of Values and Applications for Payment. Include total cost and proportionate share of general overhead and profit for each item.
 10. Show temporary facilities and other major cost items that are not direct cost of work in place either as separate line items in the Schedule of Values or distributed as general overhead expense, at Contractor's option.
 11. Schedule Updating: Update and resubmit the Schedule of Values before the next Applications for Payment when Change Orders or Construction Change Directives result in a change in the Contract Sum.

1.7 APPLICATION FOR PAYMENT

- A. Submit one electronic pdf of the application for payment on AIA G702.
 - 1. Indicate the date for each progress payment. The period of Work covered by each application is the period indicated in the Agreement
 - 2. Provide on original AIA forms.
 - 3. Complete, notarize and execute each Application for Payment by a person authorized to legally sign documents.
 - 4. Show breakdown of the work with separate labor and material amounts on AIA G703 in accordance with the accepted Schedule of Values.
 - 5. Make each application consistent with previous applications and payments as certified by Engineer and paid for by Owner.
 - 6. Engineer will return incomplete applications without action.
- B. Payment Terms: Within 45 days of receipt of engineer-approved request, Owner shall make a progress payment to the Contractor on the basis of a duly certified and approved estimate of the work performed during the preceding calendar month under this Contract.
- C. Retainage: If contract amount exceeds \$100,000, to ensure proper performance of this Contract, 5% of the amount of each estimate will be retained by the Owner until 50% completion, at which time the Owner, with written consent of the surety, shall not retain further retainage from periodic payments due the contractor if the contractor continues to perform satisfactorily and nonconforming work identified in writing prior to that time by the Engineer, engineer or owner has been corrected by the contractor and accepted by the Engineer, engineer or owner.
 - 1. If the owner determines the contractor's performance is unsatisfactory, the owner may reinstate retainage for each subsequent periodic payment application as authorized in this subsection up to the maximum amount of 5%.
 - 2. The project shall be deemed 50% complete when the contractor's gross project invoices, excluding the value of materials stored off-site, equal or exceed 50% of the value of the contract, except the value of materials stored on-site shall not exceed 20% of the contractor's gross project invoices for the purpose of determining whether the project is 50% complete.
 - 3. Within 60 days after the submission of a pay request and one of the following occurs, as specified in the contract documents, the owner with written consent of the surety shall release to the contractor retainage on payments held by the owner:
 - a. The owner receives a certificate of Substantial Completion from the Engineer in charge of the project.
 - b. The owner receives beneficial occupancy or use of the project. However, the owner may retain sufficient funds to secure completion of the project or corrections on work. If the owner retains funds, the amount retained shall not exceed two and one-half times the estimated value of the work to be completed or corrected. Reduction in the amount of the retainage on payments with the consent of the contractor's surety.

- D. Match data of entries on the schedule of values and construction schedule. Include amounts of change orders issued before last day of construction period covered by the application.
- E. The Engineer reserves the right to contact material manufacturers directly, without contractor consent, to verify material invoices. Make material invoices available to the Engineer upon his request from the contractor or material manufacturer.
- F. When requesting payment for materials stored on site, submit with request an invoice for the materials and a certificate of insurance showing proof of coverage for the materials stored on site. Payment will be made only for stored materials. No payment will be made for anticipated overhead and/or profit.
- G. With each application for payment, also submit the following:
 - 1. County/State Sales/Use Tax Statement: Submit with each pay request an original notarized statement provided by the Owner showing taxes paid on the project. List payments made directly to each supplier indicating the supplier's name, invoice date, invoice amount before taxes, taxes paid indicating state and county, and total invoice amount. If no sales taxes have been paid, indicate "NONE" on the statement form and submit accordingly.
 - 2. Unit Price Daily Logs: Submit copies of unit price daily logs and appropriate change order forms with each application for payment unless no unit price work was accomplished during the period covered by the application.
 - 3. Owner's MWSBE Program Forms
 - 4. AIA G706
 - 5. AIA G706A
- H. At substantial completion, submit an application for payment showing 100% completion for portion of the work claimed as substantially complete. Include documentation supporting claim that the work is substantially complete.
- I. At final completion, submit final application for payment with releases and supporting documentation not previously submitted and accepted, including but not limited to the following. Final payment not due until required documents have been submitted.
 - 1. Project Closeout Submittals
 - 2. Final County/State Sales/Use Tax Statement.
 - 3. Owner's MWSBE Program Forms
 - 4. AIA G706
 - 5. AIA G706A
 - 6. AIA G707

END OF SECTION

SECTION 01 31 00

PROJECT MANAGEMENT AND COORDINATION

PART 1 GENERAL

1.1 SUMMARY

- A. Section Includes:
 - 1. This Section includes administrative provisions for coordinating construction operations on Project including, but not limited to, the following:
 - a. Project Schedule
 - b. General project coordination procedures.
 - c. Coordination.
 - d. Daily Site Reporting
 - e. Administrative and supervisory personnel
 - f. Project meetings
 - g. Weekly Reports

1.2 RELATED DOCUMENTS

- A. Drawings and general provisions of the Contract, including General and Supplementary Conditions and Specification Sections apply to this Section.

1.3 SUBMITTALS

- A. Emergency contact list: Key personnel including home, office and mobile numbers, for the Owner, Contractor, Subcontractor(s), and Engineer
- B. Work schedule:
 - 1. Indicate start date, crew size, production rate, completion date, etc.
 - 2. Provide illustrated schedule on an aerial map.

1.4 COORDINATION

- A. Coordinate construction operations with those of other contractors and entities to ensure efficient and orderly installation of each part of the Work. Coordinate its operations with those included in different Sections that depend on each other for proper installation, connection, and operation.
 - 1. Schedule construction operations in sequence required to obtain the best results where installation of one part of the Work depends on installation of other components, before or after its own installation.
 - 2. Coordinate installation of different components with other contractors to ensure maximum accessibility for required maintenance, service, and repair.

3. Make adequate provisions to accommodate items scheduled for later installation.
- B. Contact Progress Reporting: Coordinate the scheduling and sequence of operations with the Owner and Engineer.
- C. If necessary, prepare memoranda for distribution to each party involved, outlining special procedures required for coordination. Include such items as required notices, reports, and list of attendees at meetings.
 1. Prepare similar memoranda for Owner and separate contractors if coordination of their Work is required.
- D. Administrative Procedures: Coordinate scheduling and timing of required administrative procedures with other construction activities and activities of other contractors to avoid conflicts and to ensure orderly progress of the Work. Such administrative activities include, but are not limited to, the following:
 1. Preparation of Construction Schedule.
 2. Preparation of the Schedule of Values.
 3. Installation and removal of temporary facilities and controls.
 4. Delivery and processing of submittals.
 5. Progress meetings.
 6. Pre-Construction conference.
 7. Pre-installation conferences.
 8. Project closeout activities.

1.5 PROJECT MEETINGS

- A. Pre-Construction Meeting
 1. A Pre-Construction Meeting will be scheduled as soon as possible after the award of the contract. The Engineer's Representative will compile minutes of the meeting and will furnish a copy of the minutes to each person present.
 2. Attendance: Project Manager, Job Superintendent and Job Foreman, Owner, Engineer's Representative, manufacturer's representatives, installers of related work and other persons concerned with the installation and performance.
 - a. Provide 3 telephone numbers to contact the Contractor or his authorized representative in the event of an emergency after normal business hours.
 3. Minimum Agenda: Organizational arrangement of Contractor's forces and personnel, and those of subcontractors, materials suppliers, and the Project Manager; channels and procedures for communication; construction schedule, including sequence of critical work; contract documents, including distribution of required copies of Drawings and revisions; processing of Shop Drawings and other data submitted to the Project Manager for review; rules and regulations governing performance of the work and procedures for safety, first aid, security, quality control, housekeeping and related matters.

B. Progress Meetings:

1. Attend bi-weekly on-site progress meetings for the purpose of informing the Owner and the Engineer regarding the status of the project. The Engineer will compile minutes of the meeting and will furnish a copy of the minutes to each person present.
2. Attendance: Owner, Engineer, Contractor Project Manager, Job Superintendent, material Supplier, and Subcontractors, as appropriate. Provide an updated job progress schedule at each weekly meeting. Be thoroughly familiar with the status of the project and be prepared to discuss and act upon situations that arise. The time, date and location of these meetings will be established during pre-construction conference.
3. Minimum Agenda: Review of work progress; field observations, problems, and decisions; identification of problems which impede planned progress; maintenance of progress schedule; corrective measures to regain projected schedules; planned progress during succeeding work period; coordination of projected progress; maintenance of quality and work standards; processing of field decisions and Change Orders; effect of proposed changes on progress, schedule, and coordination; other business relating to work.

C. Substantial Completion Inspection Meeting

1. Scheduled by Owner and Engineer upon written notification of substantial completion of work from the Contractor.
2. Attendance: Owner, Engineer, Contractor, material manufacturer.
3. Minimum Agenda: Walkover inspection, verification of substantial completion, identification of punch list items and identification of problems potentially impeding issuance of warranties.

D. Final Inspection Meeting

1. Scheduled by Owner and Engineer upon written notification of final completion of work from the Contractor.
2. Attendance: Owner, Engineer, Contractor.
3. Minimum Agenda: Verification of final completion including the completion of the punch list items.

1.6 DAILY SITE REPORTING

- A. Upon arrival daily, Contractor's lead employee to report to the facilities office or department where they are working and inform the staff that they have arrived, their reasons for being there, and the number of personnel working. "Log/Sign In" as directed by the staff and show a photo I.D. with company logo.

1.7 WEEKLY CONSTRUCTION REPORTS

- A. Prepare a weekly construction report recording the following information concerning events at Project site and Fax or email a copy to the Engineer by noon on the following Monday:
1. Approximate daily count of personnel at Project Site.

2. Daily material deliveries.
3. Daily High and low temperatures and general weather conditions.
4. Accidents.
5. Unusual events.
6. Stoppages, delays, shortages, and losses.
7. Orders and requests of authorities having jurisdiction.
8. Change Orders received and implemented.
9. Change Directives received and implemented.
10. Daily Allowance and Unit Cost usage.

END OF SECTION

SECTION 01 33 00

SUBMITTAL PROCEDURES

PART 1 GENERAL

1.1 SUMMARY

- A. Section Includes:
1. This Section includes administrative and procedural requirements for submitting Shop Drawings, Product Data, Samples, and other miscellaneous submittals.

1.2 RELATED DOCUMENTS

- A. Drawings and general provisions of the Contract, including General and Supplementary Conditions and Specification Sections apply to this Section.

1.3 SUBMITTAL PROCEDURE

- A. General: The Contractor is responsible for providing the submittals to the Engineer. Each submittal is required to be accepted in writing prior to commencement of work.
- B. Submission Requirements:
1. Submit required submittals electronically in pdf format to the Engineer for review. The submittals will then be returned electronically to the Contractor with comments. Final submittals require written responses to submittal comments.
- C. Processing Time: Allow time for submittal review, including time for resubmittals, as specified below, commencing on Engineers receipt of submittal.
1. Initial Review: Allow 7 work days for initial review of submittals.
 2. Allow 7 work days for processing each resubmittal.
 3. No extension of the Contract Time will be authorized because of failure to transmit submittals enough in advance of the Work to permit processing.
- D. Identification:
1. Submit as one pdf file with bookmarks for each scheduled item.
- E. Deviations: Highlight, encircle, or otherwise identify deviations from the Contract Documents on submittals and provide letter describing in detail proposed changes, substitutions, or deviations from the project or manufacturers specifications. Include a written explanation of why substitutions should be considered under the appropriate tab.
- F. Transmittal: Package submittals appropriately for transmittal. Engineer will discard submittals received from sources other than Contractor. Include Contractors certification stating that information submitted complies with requirements of the Contract Documents.
- G. Use for Construction: Use only final submittals with mark indicating action taken by Engineer in connection with construction.

1.4 SCHEDULE OF SUBMITTALS

- A. Refer to the applicable specification section for list of submittal requirements for each section.
- B. Submit the following submittal items electronically with a title page and/or pdf bookmark for each submittal item to meet the requirements specified herein:
 - 1. Section 00 52 13 - Copy of Executed Owner/Contractor Agreement
 - a. Copy of Contractors Certificate of Insurance
 - 2. Section 00 61 13.13: Copy of Executed Performance Bond Form
 - 3. Section 00 61 13.16: Copy of Executed Payment Bond Form
 - 4. Section 01 14 00 - Work Restrictions
 - 5. Section 01 25 00 - Substitution Procedures
 - 6. Section 01 29 00 - Payment Procedures
 - 7. Section 01 31 00 - Project Management and Coordination
 - 8. Section 01 40 00 - Quality Requirements
 - 9. Section 01 73 00 - Execution Requirements
 - 10. Section 01 77 00 - Closeout Procedures
 - 11. Section 04 05 00 - Mortar and Grout
 - 12. Section 04 05 24 - Masonry Repointing
 - 13. Section 04 20 00 - Unit Masonry
 - 14. Section 07 13 26 - Self-Adhering Sheet Waterproofing
 - 15. Section 07 62 00 - Sheet Metal Flashing and Trim
 - 16. Section 07 92 00 - Elastomeric Joint Sealants
 - 17. Section 22 14 00 - Storm Drainage
 - 18. Shop Drawings: Shop drawings or letter stating installation of materials as detailed in the Contract Drawings unless properly authorized by the Engineer.
 - 19. Existing Damage Documentation: Existing damaged/dysfunctional components documentation (videotape, photos, etc.) including but not limited to asphalt spills, windows, walls, sidewalks, paving, ceilings, etc. Lack of submission prior to commencement of work indicates no existing damaged components and Contractor takes responsibility for damages caused by operations.
 - 20. Physical color samples as specified in the applicable specification section.

PART 2 PRODUCTS

2.1 SUBMITTALS

- A. General: Prepare and submit Submittals required herein and by individual Specification Sections.
- B. Product Data: Collect information into a single submittal for each element of construction and type of product or equipment.
 - 1. If information is specially prepared for submittal because standard printed data are not suitable for use, submit as Shop Drawings, not as Product Data.
 - 2. Mark each copy of each submittal to show which products and options are applicable.
 - 3. Include the following information, as applicable:
 - a. Manufacturers written recommendations.
 - b. Manufacturers product specifications.
 - c. Manufacturers installation instructions.
 - d. Manufacturers catalog cuts.
 - e. Wiring diagrams showing factory-installed wiring.
 - f. Printed performance curves.
 - g. Operational range diagrams.
 - h. Compliance with recognized trade association standards.
 - i. Compliance with recognized testing agency standards.
- C. Shop Drawings: Prepare Project-specific information, drawn accurately to scale. Do not base Shop Drawings on reproductions of the Contract Documents or standard printed data.
 - 1. Preparation: Include the following information, as applicable: dimensions, identification of products, fabrication and installation drawings, schedules, coordination requirements and notation of dimensions established by field measurements.
 - 2. Sheet Size: Except for templates, patterns, and similar full-size drawings, submit Shop Drawings on sheets at least 8-1/2 by 11 inches but no larger than 30 by 42 inches.
- D. Samples: Prepare physical units of materials or products, including the following:

1. Samples for Verification: Submit full-size units or Samples of size indicated, prepared from the same material used for the Work, cured and finished in manner specified, and physically identical with the product proposed for use, and that show range of color and texture variations expected. Samples include, but are not limited to, partial sections of manufactured or fabricated components; small cuts or containers of materials; complete units of repetitively used materials; swatches showing color, texture, and pattern; color range sets; and components used for independent testing and inspection.
 2. Submit three sets of Samples. Engineer will retain two Sample sets; remainder will be returned.
 3. Preparation: Mount, display, or package Samples in manner specified to facilitate review of qualities indicated. Prepare Samples to match Engineers sample where so indicated. Attach label on unexposed side.
 4. Submit Samples for review of kind, color, pattern, and texture for a final check of these characteristics with other elements and for a comparison of these characteristics between final submittal and component as delivered and installed.
 5. Disposition: Maintain sets of approved Samples at Project site, available for quality-control comparisons throughout the course of construction activity and used to determine final acceptance of construction associated with each set.
- E. Qualification Data: Prepare written information that demonstrates capabilities and experience of firm or person. Include lists of completed projects with project names and addresses, names and addresses of engineers and owners, and other information specified.
- F. Product Certificates: Prepare written statements on manufacturers letterhead certifying that product complies with requirements.
- G. Installer Certificates: Prepare written statements on manufacturers letterhead certifying that Installer complies with requirements and, where required, is authorized for this specific Project.
- H. Manufacturer Certificates: Prepare written statements on manufacturers letterhead certifying that manufacturer complies with requirements. Include evidence of manufacturing experience where required.
- I. Material Certificates: Prepare written statements on manufacturers letterhead certifying that material complies with requirements.
- J. Material Test Reports: Prepare reports written by a qualified testing agency, on testing agencies standard form, indicating and interpreting test results of material for compliance with requirements.
- K. Product Test Reports: Prepare written reports indicating current product produced by manufacturer complies with requirements. Base reports on evaluation of tests performed by manufacturer and witnessed by a qualified testing agency, or on comprehensive tests performed by a qualified testing agency.
- L. Design Data: Prepare written and graphic information, including, but not limited to, performance and design criteria, list of applicable codes and regulations, and calculations. Include list of assumptions and other performance and design criteria and a summary of loads. Include load diagrams if applicable. Provide name and version of software used for calculations. Include page numbers.

- M. **Manufacturer's Instructions:** Prepare written or published information that documents manufacturers recommendations, guidelines, and procedures for installing or operating a product or equipment. Include name of product and name, address, and telephone number of manufacturer.
- N. **Insurance Certificates and Bonds:** Prepare written information indicating current status of insurance or bonding coverage. Include name of entity covered by insurance or bond, limits of coverage, amounts of deductibles, and term of the coverage.

PART 3 EXECUTION

3.1 CONTRACTORS REVIEW

- A. Review each submittal, check for compliance with the Contract Documents and note corrections and field dimensions prior to submitting to Engineer.

3.2 ENGINEERS ACTION

- A. **Submittals:** Engineer will review each submittal, make marks to indicate corrections or modifications required, and return it. Engineer will stamp each submittal item with an action stamp and will mark stamp appropriately to indicate action taken.
- B. Submittals not required by the Contract Documents will not be reviewed and may be discarded.

END OF SECTION

SECTION 01 40 00

QUALITY REQUIREMENTS

PART 1 GENERAL

1.1 SUMMARY

- A. Section Includes:
 - 1. This Section includes administrative and procedural requirements for quality assurance and quality control.
 - 2. Secure and pay costs of licenses and permits required by City, County and/or State authorities.

1.2 RELATED DOCUMENTS

- A. Drawings and general provisions of the Contract, including General and Supplementary Conditions and Specification Sections apply to this Section.

1.3 DEFINITIONS

- A. Quality-Assurance Services: Activities, actions, and procedures performed before and during execution of the Work to guard against defects and deficiencies and ensure that proposed construction complies with requirements.
- B. Quality-Control Services: Tests, inspections, procedures, and related actions during and after execution of the Work to evaluate that completed construction comply with requirements. Services do not include contract enforcement activities performed by Engineer.
- C. Authority Having Jurisdiction: AHJ

1.4 DELEGATED DESIGN

- A. Performance and Design Criteria: Where professional design services or certifications by a design professional are specifically required of Contractor by the Contract Documents, provide products and systems complying with specific performance and design criteria indicated. If criteria indicated are not sufficient to perform services or certification required, submit a written request for additional information to Engineer.

1.5 SUBMITTALS

- A. Permit: Provide copy of construction permits along with required licenses or certifications required by the AHJ.

1.6 QUALITY ASSURANCE

- A. Perform quality assurance in accordance with governing Codes, referenced standards, established standards, or industry standards.

- B. Solely responsible for supervising and directing the Work competently and efficiently, devoting such attention thereto and applying such skills and expertise necessary to perform the Work in accordance with the Contract. Solely responsible for the means, methods, techniques, sequences and procedures of construction and for coordinating portions of the Work under the Contract, except where otherwise specified in the Contract Documents. Solely responsible to the Owner that the finished Work complies with the Contract Documents.
- C. It is the intent under this contract that workmanship be of the best quality consistent with the materials and construction methods specified. The presence or absence of the Owner's or Engineer's representative in no way relieves the Contractor of his responsibility to furnish materials and construction in compliance with the drawings and specifications. The Owner and Engineer have the authority to judge the quality and require replacement of unacceptable work or personnel.
- D. Cooperate in the execution of work and plan work in such manners as to avoid conflicting schedules or delay of work. If the work depends upon the work of another Contractor, report defects affecting the work to the Engineer. Commencement of work where such condition exists constitute acceptance of the other Contractor's work as being satisfactory to receive the work commenced. Coordinate work of trades under this contract in such a manner to obtain the best possible workmanship for the project. Install components of the work in accordance with the best practices of the particular trade. Notify the Owner sufficiently in advance of operations to allow for assignment of personnel.
- E. Solely responsible for health and safety precautions and programs for workers and others in connection with the Work. No inspection by, knowledge on the part of, or acquiescence by the Engineer, the Owner, the Owner's employees and agents, or other entity whatever relieves the Contractor from its sole responsibility for compliance with the requirements of the Contract or its sole responsibility for health and safety programs and precautions.
- F. Materials or methods described by words which, when applied, have a well-known technical or trade meaning are held to refer to such recognized standard. Standard specifications or manufacturer's literature, when referenced, are of the latest revision or printing unless otherwise stated, and are intended to establish the minimum requirements acceptable.
- G. When special makes or grades of material which are normally packaged by the supplier or manufacturer are specified or accepted, deliver materials to the site in original packages or containers with seals unbroken and labels intact and do not open until reviewed and accepted by the Engineer. Notify the Engineer prior to such material's delivery.
- H. Provide new materials unless otherwise indicated.
- I. Provide workmanship in accordance with the best modern practice.
- J. Verify dimensions and conditions at the site prior to starting work and notify the Engineer immediately of any errors or inconsistencies.
- K. Maintain one set of the contract documents and accepted submittals at the job site.
- L. Correct deficiencies identified by Engineer and non-conforming work within 24 hours of receipt of notification, either verbally or written, and submit a plan of action for addressing the deficiencies and non-conforming work. Do not proceed with further tear-off or commencement of other work until deficiencies and non-conforming work are properly addressed.
- M. Control of Installation

1. Monitor quality control over suppliers, manufacturers, products, services, site conditions, and workmanship, to produce work of specified quality.
2. Comply with manufacturers' instructions, including each step in the sequence
3. Request clarification from Engineer before proceeding in the event manufacturers' instructions conflict with Contract Documents.
4. Comply with specified standards as the minimum quality for the Work, except where more stringent tolerances, codes, or specified requirements indicate higher standards or more precise workmanship.
5. Only allow Work performed by person qualified to produce workmanship of specified quality.
6. Secure products in place with positive anchorage devices designed and sized to withstand stresses, vibration, physical distortion, or disfigurement.

N. Tolerances:

1. Monitor tolerance control of installed products to produce acceptable work. Do not permit tolerances to accumulate.
2. Comply with manufacturers' tolerances. Request clarification from Engineer in the event manufacturers' tolerances conflict with Contract Documents.
3. Adjust products to appropriate dimensions; position before securing products in place.

O. Installer Qualifications: A firm or individual experienced in installing, erecting, or assembling work similar in material, design, and extent to that indicated for this Project, whose work has resulted in construction with a record of successful in-service performance.

1. Maintain applicable federal, state and municipal licenses.
2. Be certified in writing for a minimum of 2 years by the roofing materials manufacturer to install the primary roofing products.
3. Have a minimum of 5 years' experience in installing the same or similar materials specified under the same firm name as that submitting the bid. If requested, submit a copy of firm's Articles of Incorporation to verify years in business. Crew workers on site are experienced and have a working knowledge of the system being installed.
4. Principals of the firm to have a minimum of 10 years' experience in the estimating, supervision, management and administration of a contracting firm engaged in work similar to work as specified.
5. Licensed by state work is occurring in for the type and dollar amount of work contemplated by these Contract Documents.
6. Never filed bankruptcy or filed for protection from creditors.

7. During the construction and completion of work covered by these Specifications, if the conduct of workers of the various crafts is determined unsuitable or a nuisance to the Owner or Engineer, or if the workman is considered incompetent or detrimental to the work, order such party removed from the grounds with the person not returning during the course of work on the project.
 8. Superintendent: During the performance of work by the Contractor or subcontractors, provide an on site and full time superintendent/representative meeting the following requirements:
 - a. For the purpose of these Specifications the designation "superintendent" is hereby defined as the individual present on the job site while work is being performed, and whose primary responsibility is to supervise and direct the performance of the Work.
 - b. Be in attendance at the project site during the progress of the work and duties as superintendent limited to this project only. Supervise and instruct workmen without engaging in the work process. If superintendent is absent temporarily from the project, designate a competent foreman to assume duties. During the superintendent's absence, foreman cannot engage in the work process; supervise and instruct only. Likewise, communications given to the foreman are binding as if given to the Contractor.
 - c. Communicate matters pertaining to the Work with the Owner and Engineer. Do not make decisions regarding changes in the Work without the Owner and Engineer's knowledge.
 - d. Decision making authority and ability.
 - e. Able to demonstrate knowledge of work being installed.
 - f. Fluent in the English language (reading, writing and speaking).
 - g. In possession of mobile telephone.
 - h. Employed by the Contractor at least six months prior to project commencement.
 - i. Owner approval and Engineer acceptance.
 - j. Once approved, do not change the superintendent except with the consent of the Owner unless he proves unsatisfactory to the Owner or Contractor or is no longer employed.
 - k. Minimum of five 5 years continuous experience as a job superintendent.
 9. No later than ten days prior to the pre-construction conference, provide the Owner, in writing, the names of the proposed project manager, superintendent, and foreman for approval. If he so determines, the Owner, without giving cause, may request an additional name, or names, be submitted for approval. The Owner will notify the Contractor of his acceptance at least 48 hours prior to the pre-construction conference.
- P. Specialists: Certain sections of the Specifications require that specific construction activities be performed by entities who are recognized experts in those operations. Specialists satisfy qualification requirements indicated and be engaged for the activities indicated.

- Q. Fabricator Qualifications: A firm experienced in producing products similar to those indicated for this Project and with a record of successful in-service performance, as well as sufficient production capacity to produce required units.
- R. Factory-Authorized Service Representative Qualifications: An authorized representative of manufacturer who is trained and approved by manufacturer to inspect installation of manufacturer's products that are similar in material, design, and extent to those indicated for this Project.

1.7 QUALITY CONTROL

- A. The authorized representatives and agents of Owner permitted to inspect work, materials, payrolls, records of personnel, invoices of materials, and other relevant data and records.
- B. Owner Responsibilities:
 - 1. Where quality-control services are indicated as Owner's responsibility, Owner will engage a qualified testing agency to perform these services.
 - a. Owner will furnish Contractor with names, addresses, and telephone numbers of testing agencies engaged and a description of the types of testing and inspecting they are engaged to perform.
 - b. Costs for retesting and reinspecting construction that replaces or is necessitated by work that failed to comply with the Contract Documents will be charged to Contractor.
- C. Contractor Responsibilities:
 - 1. Repair and protection of work and materials.
 - 2. Replace work or materials not conforming with requirements of the Specifications or damaged during the progress of the work before completion and acceptance of the project.
 - 3. Coordinate documents with manufacturer and perform such testing, reporting, and communication incidental to provisions of the warranty procedures.
 - 4. Inclement Weather
 - a. In the event of temporary suspension of work during inclement weather, or whenever the Engineer recommends, protect carefully its work and materials against damage or injury from weather. If work or materials have been damaged by reason of failure to protect the work, replace such materials.
 - b. During inclement weather and temporary suspension of work, inspect the facility no later than 9:00 AM each day for leaks and perform temporary repairs if necessary. Make inspections daily during extended periods of inclement weather. Upon arrival at the facility, inform the Owner of his presence and purpose.

- c. If inspection of the facility does not occur by 9:00 AM on days of inclement weather and there is one or more leaks attributable to the Work, at 9:15 AM the Owner can exercise his right to contact an outside contractor to perform temporary repairs as necessary to prevent damage to the building, its contents and to minimize disruption. Reimburse the outside contractor an equitable amount as determined solely by the outside contractor. If the Contractor arrives at the project site after the outside contractor has been contacted, but before temporary repairs are made, reimburse the amount contractor the fixed amount of \$500.00, each occasion, for mobilization and/or travel expenses.
 - d. In the event inclement weather occurs after normal business hours, Saturday, Sunday or holidays, make arrangements with the Owner to provide access to the building to inspect for leaks. Compensate Owner for providing personnel for the service on an hourly rate basis as determined solely by the Owner.
- D. Manufacturer's Field Services: During construction, perform quality assurance site visits monthly by manufacturer's technical representative to ensure materials are being properly installed and as required to obtain the specified warranty.
- 1. The first site visit performed within the first three (3) days of operations.
 - 2. Coordinate site visits with Engineer. Submit reports of findings within one week of inspection. Payment applications will be rejected until applicable reports are received.
 - 3. Inspections to be performed by an employee of the selected manufacturer that is assigned full time to their technical services department. Sales personnel are not acceptable for this function and may result in rejection of the work installed that does not fulfill this requirement.
 - 4. Manufacturer's final inspections performed only with REI personnel in attendance. A minimum of seven days' written notice is required. Manufacturer's final inspection conducted without REI personnel in attendance will be repeated at no additional cost to the Owner.
 - 5. Violation of these requirements results in the removal of that manufacturer for a period of not less than one year from the Engineer's accepted materials list.

PART 2 PRODUCTS (NOT USED)

PART 3 EXECUTION

3.1 REPAIR AND PROTECTION

- A. On completion of testing, inspecting, sample taking, and similar services, repair damaged construction and restore substrates and finishes.
- B. Protect construction exposed by or for quality control service activities.
- C. Repair and protection are Contractor's responsibility, regardless of the assignment of responsibility for quality control services.

END OF SECTION

SECTION 01 42 00

REFERENCE STANDARDS

PART 1 GENERAL

1.1 SECTION INCLUDES

- A. Requirements relating to referenced standards.

1.2 RELATED DOCUMENTS

- A. Drawings and general provisions of the Contract, including General and Supplementary Conditions and Specification Sections apply to this Section.

1.3 REFERENCE STANDARDS

- A. Reference standards are specified in Part 1 of the applicable specification section.
- B. For products or workmanship specified by reference to a document or documents not included in the Project Manual, also referred to as reference standards, comply with requirements of the standard, except when more rigid requirements are specified or are required by applicable codes.
- C. Comply with the reference standard of date of issue current on date of Contract Documents, except where a specific date is established by applicable code.
- D. Should specified reference standards conflict with Contract Documents, request clarification from the Engineer before proceeding.
- E. Neither the contractual relationships, duties, or responsibilities of the parties in Contract nor those of the Engineer shall be altered by Contract Documents by mention or inference otherwise in any reference document.

1.4 BUILDING CODE

- A. Comply with the building code and energy conservation code/standard in effect in North Carolina and current on date of Contract Documents.
 - 1. 2018 North Carolina Building Code
 - 2. 2018 North Carolina Energy Conservation Code

END OF SECTION

SECTION 01 50 00

TEMPORARY FACILITIES AND CONTROLS

PART 1 GENERAL

1.1 SUMMARY

A. Section Includes:

1. This Section includes requirements for temporary facilities and controls, including temporary utilities, support facilities, and security and protection facilities.

1.2 RELATED DOCUMENTS

A. Drawings and general provisions of the Contract, including General and Supplementary Conditions and Specification Sections apply to this Section.

1.3 REFERENCE STANDARDS

- A. NFPA 10 - Standard for Portable Fire Extinguishers; 2022.
- B. NFPA 70 - National Electrical Code; Most Recent Edition Adopted by Authority Having Jurisdiction, Including All Applicable Amendments and Supplements.
- C. NFPA 241 - Standard for Safeguarding Construction, Alteration, and Demolition Operations; 2022, with Errata (2021).

1.4 USE CHARGES

A. Include in Contract, cost or use charges for temporary facilities which are not chargeable to Owner. Allow other entities to use temporary services and facilities without cost, including, but not limited to, Owner's construction forces, occupants of testing and inspecting agencies and personnel of authorities having jurisdiction.

1.5 QUALITY ASSURANCE

- A. Comply with ANSI A10.6, NECA's "Temporary Electrical Facilities," and NFPA 241 .
- B. Comply with NECA, NEMA, and UL standards and regulations for temporary electric service. Install service to comply with NFPA 70 .
- C. Tests and Inspections: Arrange for authorities having jurisdiction to test and inspect each temporary utility before use. Obtain required certifications and permits.
- D. Develop and supervise an overall fire-prevention and first-aid fire-protection program for personnel at Project site. Review needs with local fire department and establish procedures. Instruct personnel in methods and procedures. Post warnings and information.

PART 2 PRODUCTS

2.1 MATERIALS

A. General: Provide new materials or utilize undamaged, previously used materials in serviceable condition if accepted by Engineer. Provide materials suitable for use intended.

- B. Fencing:
 - 1. Safety Fence: Safety orange high density polyethylene fabric with a minimum of 4 feet in height, 15 lbs. per 100 linear feet. Painted steel fence posts with ground anchors and metal tabs stationed often enough to hold the fabric at a minimum height of 3 feet 8 inches tall.
- C. Tarpaulins: Fire-resistive labeled with flame-spread rating of 15 or less.
- D. Water: Potable.
- E. Self-Contained Toilet Units: Single-occupant units of chemical, aerated recirculation, or combustion type; vented; enclosed with a glass-fiber-reinforced polyester shell or similar nonabsorbent material with a self-contained or standalone exterior handwashing station.
- F. Electrical Outlets: Properly configured, NEMA-polarized outlets to prevent insertion of 110 to 120-V plugs into higher-voltage outlets; equipped with ground-fault circuit interrupters, reset button, and pilot light.
- G. Fire Extinguishers: Hand carried, portable, UL rated. Provide class and extinguishing agent as indicated or a combination of extinguishers of NFPA-recommended classes for exposures. Comply with NFPA 10 and NFPA 241 for classification, extinguishing agent, and size required by location and class of fire exposure and the requirements of the local Governing agency.
- H. Ground Protection Mats: 4 foot by 8 foot, HDPE infused with rubber for traction mats designed to protect landscaping from construction equipment.
- I. Overhead Protection Scaffolds: Provide at building egress locations in accordance with OSHA 1926 Subpart L.

PART 3 EXECUTION

3.1 TEMPORARY UTILITIES

- A. Water Service: Water for construction purposes is available from the Owner at no charge. Operate exterior hose bids only with properly fitted handles. Remove at the end of each workday. Repair damage to hose bids or hose bib stems. Do not operate hose bibs with pliers.
- B. Electrical Power Service: Provide portable generators for electrical power requirements.
 - 1. Electric Distribution: Provide receptacle outlets adequate for connection of power tools and equipment. Provide waterproof connectors to connect separate lengths of electrical power cords if single lengths do reach areas where construction activities are in progress. Do not exceed safe length-voltage ratio.

3.2 CONSTRUCTION FACILITIES

- A. Temporary construction facilities include the following:
 - 1. Field Office: prefabricated, mobile units or job-built construction with lockable entrances and serviceable finishes including lights and utilities.
 - 2. Sanitary Facilities: Provide temporary toilets, wash facilities, and drinking-water fixtures. Comply with regulations and health codes for type, number, location, operation, and maintenance of fixtures and facilities. Located facilities at sites approved by Owner. Access inside the facility is not available.

- a. Disposable Supplies: Provide toilet tissue, paper towels, paper cups, and similar disposable materials for each facility. Maintain adequate supply. Provide covered waste containers for disposal of used material.
 - b. Toilets: Install self-contained toilet units. Shield toilets to ensure privacy.
 - c. Wash Facilities: Provide adequate hand washing stations.
 - d. Drinking-Water Facilities: Provide bottled-water, drinking-water units.
3. Waste Disposal Facilities: Provide waste-collection containers in sizes adequate to handle waste from construction operations at a location approved by the Owner. Containerize and clearly label hazardous, dangerous, or unsanitary waste materials separately from other waste. Use of Owner's waste disposal facilities is not acceptable.
- a. If required by authorities having jurisdiction, provide separate containers, clearly labeled, for each type of waste material.

3.3 TEMPORARY BARRIERS, ENCLOSURES AND CONTROLS

- A. Provide temporary barriers and enclosures for protection from exposure, foul weather, construction operations and other activities. Protect buildings and grounds from damages during construction.
- B. Comply with standards and code requirements for erecting structurally adequate barricades. Paint with appropriate colors, graphics, and warning signs to inform personnel and public of possible hazard. Where appropriate and needed, provide lighting, including flashing red or amber lights.
- C. Provide security controls to protect work and materials at the project site.
- D. Provide fencing to enclose the materials storage and staging area.
- E. Protection of roof areas: Provide protection to roof systems in the form of 3/4 inch CDX plywood over 1.5 inch rigid insulation with warning flags on both sides. Limit foot and equipment traffic to protected walkways.
- F. Provide and maintain suitable temporary sidewalks, closed passageways, fences, or other structures required by law so as not to obstruct or interfere with traffic in public streets, alley ways, or private right-of-way. Leave an unobstructed way along public and private places for pedestrians and vehicles.
- G. Provide walks over and around all obstructions in public places. Maintain sufficient light and guards to protect persons from injury.
- H. Provide emergency egress from existing occupied areas at all times as required by AHJ. Maintain egress path in compliance with requirements of the applicable building code.

3.4 PROTECTION FACILITIES INSTALLATION

- A. Provide environmental protection by methods that comply with environmental regulations and that minimize possible air, waterway, and subsoil contamination or pollution or other undesirable effects.
- B. Provide storm water controls sufficient to prevent flooding from heavy rain.
- C. Protection of materials stored on site.

1. Material storage will be designated by the Owner at the Pre-Construction Meeting.
2. Protect materials stored on the job site from theft and weather related damage.
3. Store as much material in locked trailers as practicable.
4. Place no more material on the job site than is necessary to maintain the work schedule.
5. Do not deliver materials prior than 7 days earlier than work commencing.

3.5 TREE AND PLANT PROTECTION:

- A. Contractors are hereby reminded and cautioned that care shall be exercised to protect trees and plants which are to remain during the progress of the Project. Suitable barriers shall be provided around all trees and plants that are to remain and which are in the construction area and product handling area. All damage to such trees and plants shall be repaired; broken limbs properly and neatly pruned and painted with pruning paint; all trunk damage neatly dressed and painted with pruning paint. Any trees and plants which are excessively damaged shall be replaced in like, kind, size, and species by The Contractor at no additional cost. All work shall be by a recognized and approved nursery.
1. All grading around trees and plants to remain shall be such that the root system shall not be disturbed. Earth shall not be temporarily piled around trees and plants, nor shall earth be graded to the trees and plants above the natural root depth for that particular species.
 2. Established trees and plants, which are in the way of construction and which are in the material handling areas, shall be removed and stored for future replanting. The services of a recognized and approved nursery shall be employed to remove the trees and plants and prepare them for storage. Removed trees and plants shall be properly balled and burlapped in accordance with their size. During the time of storage, they shall be properly watered and cared for in accordance with the instructions from the nursery. After the construction work is completed, the stored trees and plants shall be replanted, and those trees and plants not replanted shall be disposed of as directed by the Owner.

3.6 CRANES, HOISTS AND LIFTING

- A. Where cranes and other lifting equipment are required, develop and maintain a plan to execute the work in a safe manner including the following items at a minimum:
1. Erection, climbing and dismantling process
 2. Inspection process for equipment and rigging
 3. Exclusion zones
 4. Maintenance processes
 5. Identification of Qualified/Competent persons
 6. Lifting plan
 7. Process for identifying and working around aerial hazards
 8. Signalmen communication

- 9. Working around energized lines
- 10. Ground conditions and underground hazards
- B. Ensure that cranes and lifting equipment are certified for use by a Qualified/Competent person prior to first use and annually (at a minimum).
- C. Ensure that cranes and lifting equipment are inspected as required by a third party Qualified/Competent person.
- D. Provide ground protection mats over landscaped areas beneath lifts.
- E. Do not operate or travel lifts over curbs or sidewalks. Where necessary to travel equipment over curbs or sidewalks, provide adequate protection to prevent damage.

3.7 PROJECT SIGNAGE

- A. Provide temporary signs to provide information to building occupants directing them away from construction operations.
- B. Provide signage inside adjacent buildings alerting occupants of the Work Area.

3.8 VEHICULAR ACCESS AND PARKING

- A. Parking for vehicles available only in the approved Set-up and Staging area. No other vehicle parking on site is allowed.
- B. Owner Personnel vehicles will be removed from the construction area prior to the start of construction.

3.9 TRAFFIC CONTROLS

- A. Obtain and erect street/parking lot signage as necessary to divert traffic away from staging areas, work area, etc. Coordinate signage requirements with the Owner and Engineer.
- B. Provide temporary traffic controls at junction of temporary roads with public roads. Include warning signs for public traffic and "STOP" signs for entrance onto public roads. Comply with requirements of authorities having jurisdiction.

END OF SECTION

SECTION 01 73 00

EXECUTION REQUIREMENTS

PART 1 GENERAL

1.1 SUMMARY

A. Section Includes:

1. General procedural requirements governing execution of the Work.

1.2 RELATED DOCUMENTS

A. Drawings and general provisions of the Contract, including General and Supplementary Conditions and Specification Sections apply to this Section.

1.3 SUBMITTALS

A. List of Materials on the project site including manufacturer name and product name.

B. Safety Data Sheets (SDS):

1. Safety Data Sheets (SDS) for materials/products anticipated for use and stored or brought to the site for completion of this project.
2. Maintain on site with the Superintendent a set of SDS for products/materials on site.

PART 2 PRODUCTS

2.1 MATERIALS

A. Material storage area designated by the Owner at the Pre-Bid and Pre-Construction Meetings and/or indicated in Contract Drawings.

1. Store materials as required by the manufacturer and indicated in their installation instructions.
2. Store materials as required by their respective specification section.
3. Properly secure materials to resist wind events.

B. Deliver and transport materials to project in accordance with the Owner's requirements and coordinate material deliveries with Owner.

C. Hazardous Materials:

1. Use products, cleaners, and installation materials that are not considered hazardous.
2. Store chemicals in a fireproof cabinet. Store only like materials together in a cabinet. Ensure labels are intact or to place labels on chemicals prior to delivery to site.

PART 3 EXECUTION

3.1 EXAMINATION

- A. Existing Conditions:
 - 1. The existence and location of site improvements, utilities, and other construction indicated as existing are not guaranteed. Before beginning work, investigate and verify the existence and location of construction affecting the Work.
- B. Existing Utilities:
 - 1. The existence and location of utilities and construction indicated as existing are not guaranteed.
 - 2. Before construction, verify the location and points of connection of utility services.
 - 3. Before beginning work, investigate and verify the existence and location of utilities and other construction affecting the Work.
- C. Acceptance of Conditions:
 - 1. Examine areas, and conditions, with Installer or Applicator present where indicated, for compliance with requirements for installation tolerances and other conditions affecting performance.
 - 2. Written Report: Where a written report listing conditions detrimental to performance of the Work is required by other Sections, include a description of the work, list of detrimental conditions, list of unacceptable installation tolerances and recommended corrections.
 - 3. Proceed with installation only after unsatisfactory conditions have been corrected. Proceeding with the Work indicates acceptance of surfaces and conditions.

3.2 PREPARATION

- A. Field Measurements: Take field measurements as required to fit the Work properly. Recheck measurements before installing each material. Where portions of the Work are indicated to fit to other construction, verify dimensions of other construction by field measurements before fabrication. Coordinate fabrication schedule with construction progress to avoid delaying the Work.
- B. Space Requirements: Verify space requirements and dimensions of items shown diagrammatically on Drawings.
- C. Review of Contract Documents and Field Conditions: Upon discovery of the need for clarification of the Contract Documents, submit a request for information to Engineer. Include a detailed description of problem encountered, together with recommendations for changing the Contract Documents.

3.3 INSTALLATION

- A. Locate the Work and components of the Work accurately, in correct alignment and elevation, as indicated.
- B. Install products at the time and under conditions that ensure the best possible results. Maintain conditions required for product performance until Substantial Completion.

- C. Conduct construction operations so no part of the Work is subjected to damaging operations or loading in excess of that expected during normal conditions of occupancy.

3.4 STARTING AND ADJUSTING

- A. Test equipment to verify proper operation. Test and adjust controls and safeties. Replace damaged and malfunctioning controls and equipment.

3.5 PROTECTION OF INSTALLED CONSTRUCTION

- A. Provide protection and maintain conditions that ensure installed Work is without damage or deterioration at time of Substantial Completion.

3.6 CORRECTION OF THE WORK

- A. Restore permanent facilities used during construction to their specified condition.
- B. Replace components that are not up to specification standards.

END OF SECTION

SECTION 01 74 00

CLEANING AND WASTE MANAGEMENT

PART 1 GENERAL

1.1 SUMMARY

- A. Section Includes:
 - 1. Administrative and Procedural requirements for progress cleaning and construction waste management.

1.2 RELATED DOCUMENTS

- A. Drawings and general provisions of the Contract, including General and Supplementary Conditions and Specification Sections apply to this Section.

1.3 REFERENCE STANDARDS

- A. NFPA 241 - Standard for Safeguarding Construction, Alteration, and Demolition Operations; 2022, with Errata (2021).

1.4 DEFINITIONS

- A. Waste: Material that has reached the end of its intended use. Waste includes salvageable, returnable, recyclable and reusable material.
- B. Construction waste: Solid wastes including, but not limited to, building materials, packaging materials, debris and trash resulting from construction operations.
- C. Salvage: To remove a waste material from the Project site to another site for resale or reuse by others.
- D. Hazardous waste: Material or byproduct of construction that is regulated by the Environmental Protection Agency and cannot be disposed in a landfill or other waste end-source without adherence to applicable laws.
- E. Trash: Product or material unable to be returned, reused, recycled or salvaged.
- F. Landfill: Public or private business involved in the practice of trash disposal.

1.5 CLOSEOUT SUBMITTALS

- A. Landfill charge tickets

PART 2 PRODUCTS

2.1 MATERIALS

- A. Cleaning Agents: Use cleaning materials and agents recommended by manufacturer or fabricator of the surface to be cleaned. Do not use cleaning agents that are potentially hazardous to health or property or cause damage to finished surfaces.

PART 3 EXECUTION

3.1 PROGRESS CLEANING

- A. General: Clean Project site and work areas daily, including common areas. Coordinate progress cleaning for joint-use areas where more than one installer has worked. Enforce requirements strictly. Dispose of materials in a legal manner.
 - 1. Comply with requirements in NFPA 241 for removal of combustible waste materials and debris.
 - 2. Do not hold materials more than 7 days during normal weather or 3 days if the temperature is expected to rise above 80 deg F.
 - 3. Containerize hazardous and unsanitary waste materials separately from other waste. Mark containers appropriately and dispose of legally, according to regulations.
- B. Site:
 - 1. Maintain Project site free of waste materials and debris.
 - 2. Keep site free of nails, screws, fasteners and scrap metal. Utilize magnets as necessary to sweep parking lots, driveways and sidewalks. Responsible for repair or replacement of punctured tires of site occupants.
- C. Work Areas: Clean areas where work is in progress to the level of cleanliness necessary for proper execution of the Work.
 - 1. Remove liquid spills promptly.
 - 2. Where dust impairs proper execution of the Work, broom-clean or vacuum the work area, as appropriate.
 - 3. If necessary, have a heavy-duty vacuum on site to remove small, loose debris from work area.
- D. Installed Work: Keep installed work clean. Clean installed surfaces according to written instructions of manufacturer or fabricator of product installed, using only cleaning materials specifically recommended. If specific cleaning materials are not recommended, use cleaning materials that are not hazardous to health or property and do not damage exposed surfaces.
- E. Concealed Spaces: Remove debris from concealed spaces before enclosing the space.
- F. Exposed Surfaces: Clean exposed surfaces and protect as necessary to ensure freedom from damage and deterioration at time of Final Acceptance.
- G. Cutting and Patching: Clean areas and spaces where cutting and patching are performed. remove paint, mortar, oils, putty, and similar materials. Thoroughly clean piping, conduit, and similar features before applying paint or other finishing materials. Restore damaged pipe covering to its original condition.
- H. Waste Disposal: Burying or burning waste materials on-site is not permitted. Washing waste materials down sewers or into waterways is not permitted.

- I. During handling and installation, clean and protect construction in progress and adjoining materials already in place. Apply protective covering where required to ensure protection from damage or deterioration at Final Acceptance.
- J. Clean and provide maintenance on completed construction as frequently as necessary through the remainder of the construction period. Adjust and lubricate operable components to ensure operability without damaging effects.
- K. Limiting Exposures: Supervise construction operations to ensure that no part of the construction completed or in progress, is subject to harmful, dangerous, damaging, or otherwise deleterious exposure during the construction period.

3.2 DISPOSAL OF WASTE

- A. General: Except for items or materials to be salvaged, recycled, or otherwise reused, remove waste materials from Project site and legally dispose of them in a landfill or incinerator acceptable to authorities having jurisdiction.
 - 1. Except as otherwise specified, do not allow waste materials to accumulate on-site.
 - 2. Remove and transport debris in a manner that prevents spillage on adjacent surfaces and areas.
- B. Burning: Do not burn waste materials.
- C. Disposal: Remove waste materials from Owner's property and legally dispose of them.
- D. Separate, store and dispose of hazardous wastes in accordance with local and EPA regulations and additional criteria listed below:
 - 1. Do not incinerate building products manufactured with PVC or containing chlorinated compounds.
 - 2. Disposal of fluorescent tubes to open containers is not permitted.
 - 3. Do not co-mingle unused fertilizers with construction waste.

3.3 FINAL CLEANING

- A. General: Provide final cleaning. Conduct cleaning and waste-removal operations to comply with local laws and ordinances and Federal and local environmental and antipollution regulations.
- B. Cleaning: Employ experienced workers or professional cleaners for final cleaning. Clean each surface or unit to condition expected in an average commercial building cleaning and maintenance program. Comply with manufacturer's written instructions.
 - 1. Complete the following cleaning operations before requesting inspection for certification of Substantial Completion.
 - 2. Clean Project site, yard, and grounds, in areas disturbed by construction activities, including, waste material, litter, and other foreign substances.
 - 3. Sweep paved areas broom clean. Remove petrochemical spills, stains, and other foreign deposits.

4. Remove tools, construction equipment, machinery, and surplus material from Project site. Properly dispose of unwanted surplus material.
 5. Clean exposed exterior and interior hard-surfaced finishes to a dirt-free condition, free of stains, films, and similar foreign substances. Avoid disturbing natural weathering of exterior surfaces. Restore reflective surfaces to their original condition.
 6. Remove debris and surface dust from roofs and walls.
 7. Clean transparent materials and glass in windows. Remove glazing compounds and other noticeable, vision-obscuring materials. Replace chipped or broken glass and other damaged transparent materials.
 8. Remove labels that are not permanent.
 9. Touch up and otherwise repair and restore marred, exposed finishes and surfaces. Replace finishes and surfaces that cannot be satisfactorily repaired or restored or that already show evidence of repair or restoration.
 10. Wipe surfaces of mechanical and electrical equipment and similar equipment. Remove excess foreign substances.
 11. Replace parts subject to unusual operating conditions.
 12. Leave Project clean and ready for occupancy.
- C. Comply with safety standards for cleaning. Do not burn waste materials. Do not bury debris or excess materials on Owner's property. Do not discharge volatile, harmful, or dangerous materials into drainage systems. Remove waste materials from Project site and dispose of lawfully.

END OF SECTION

SECTION 01 77 00
CLOSEOUT PROCEDURES

PART 1 GENERAL

1.1 SUMMARY

- A. Section Includes:
1. This Section includes administrative and procedural requirements for contract closeout, including, but not limited to, the following:
 - a. Inspection Procedures.
 - b. Project Record Documents.
 - c. Warranties.

1.2 RELATED DOCUMENTS

- A. Drawings and general provisions of the Contract, including General and Supplementary Conditions and Specification Sections apply to this Section.

1.3 SUBMITTALS

- A. Warranties: Submit copy of warranties to meet the requirements of their respective specification section.

1.4 SUBSTANTIAL COMPLETION

- A. Submit written certification to the Engineer that the Project is substantially complete along with the following:
1. Prepare a list of items to be completed and corrected (Contractor's punch list), the value of items on the list, and reasons why the Work is not complete.
 2. Notify Owner of pending insurance changeover requirements.
 3. Obtain and submit releases permitting Owner unrestricted use of the Work and access to services and utilities. Include occupancy permits, operating certificates, and similar releases.
 4. Terminate and remove temporary facilities from Project site, along with mockups, construction tools, and similar elements.
 5. Notify Owner of changeover in heat and other utilities.
 6. Submit changeover information related to Owner's occupancy, use, operation, and maintenance.
 7. Complete final cleaning requirements, including touchup painting.
 8. Touch up and otherwise repair and restore marred exposed finishes to eliminate visual defects.

- B. Substantial Completion Inspection: On receipt of written substantial completion certification, the Engineer will make a substantial completion inspection within 7 days after receipt of certification.
1. Should the Engineer consider the Work not substantially complete, he will notify the Contractor, in writing, stating the reasons. Complete the Work and send a second written notice to the Engineer, certifying the Project is substantially complete, at which time the Engineer will re-inspect the work.
 2. Should the Engineer consider the Work substantially complete, he will prepare and issue a Certificate of Substantial Completion accompanied by the list of items to be completed or corrected (Punch List).
 3. A punch list of items will be prepared for correction and completion before the Final Inspection. Complete the punch list items within 15 days of the punch list inspection. If the Contractor fails to complete the punch list within this period, the Owner has the right to impose liquidated damages in the amount of \$500.00 for each consecutive day until the items are completed.

1.5 FINAL COMPLETION

- A. Preliminary Procedures: Before requesting final inspection for determining date of Final Completion, complete the following:
1. Submit a final Application for Payment according to Division 01.
 2. Submit signed copy of Engineer's inspection list of items to be completed or corrected (punch list) certifying each item has been completed or otherwise resolved for acceptance.
 3. Submit evidence of final, continuing insurance coverage complying with insurance requirements.
 4. Instruct Owner's personnel in operation, adjustment, and maintenance of products, equipment, and systems.
- B. Final Inspection: The submission of the signed punch list constitutes as written request for final inspection for acceptance. On receipt of request, Engineer along with the Owner's Representative will conduct a final inspection within 7 days of receipt of certification.
1. Should the Engineer consider that the Work is finally complete in accordance with requirements of the Contract Documents, Project Closeout Submittals will be requested.
 2. Should the Engineer consider that the Work is not finally complete, notification to the Contractor, in writing, stating the reasons will be made.
 3. Take steps to remedy the stated deficiencies and send a second written notice to the Engineer certifying that the Work is complete, at which time the Engineer will re-inspect the Work.

1.6 PROJECT RECORD DOCUMENTS

- A. General: Do not use Project Record Documents for construction purposes. Protect Project Record Documents from deterioration and loss. Provide access to Project Record Documents for Engineer's reference during normal working hours.

1. Submit required record documents and warranties within 30 days of the punch list inspection. If the Contractor fails to properly submit required items within this period, the Owner has the right to impose liquidated damages in the amount of \$500.00 for each consecutive day until the items are properly submitted.
- B. Record Drawings: Maintain and submit one set of blue- or black-line white prints of Contract Drawings and Shop Drawings.
1. Mark Record Prints to show where installation varies from that shown originally. Require individual or entity who obtained record data, whether individual or entity is Installer, subcontractor, or similar entity, to prepare the marked-up Record Prints.
 - a. Give particular attention to information on concealed elements that cannot be readily identified and recorded later.
 - b. Record data as soon as possible after obtaining it. Record and check the markup before enclosing concealed installations.
 2. Mark record sets with erasable, red-colored pencil. Use other colors to distinguish between changes for different categories of the Work at the same location.
 3. Note Construction Change Directive numbers, Change Order numbers, alternate numbers, and similar identification where applicable.
 4. Identify and date each Record Drawing; include the designation "PROJECT RECORD DRAWING" in a prominent location. Organize into manageable sets; bind each set with durable paper cover sheets. Include identification on cover sheets.
- C. Record Specifications: Submit one copy of Project's Specifications, including addenda and contract modifications. Mark copy to indicate where installation varies from that indicated in Specifications, addenda, and contract modifications.
1. Give particular attention to information on concealed products and installations that cannot be readily identified and recorded later.
 2. Mark copy with the proprietary name and model number of products, materials, and equipment furnished, including substitutions and product options selected.
 3. Note related Change Orders and Record Drawings, where applicable.
- D. Miscellaneous Record Submittals: Assemble miscellaneous records required by other Specification Sections for miscellaneous record keeping and submittal in connection with performance of the Work. Bind or file miscellaneous records and identify each, ready for continued use and reference.
1. Completed and signed Engineer's Punch List

1.7 WARRANTIES

- A. Warranties to commence on the date of Substantial Completion of the project.
- B. Elastomeric Joint Sealant warranty as outlined in Section 07 92 00 - Elastomeric Joint Sealants.

- C. Two Year Warranty: Manufacturer's Representative and Contractor's Representative will attend post construction field inspection no earlier than one month prior to the expiration date of the Contractor's Warranty. Submit a written report within 7 days of the site visit to the Engineer listing observations, conditions and recommended repairs or remedial action.
- D. Section 00 65 37 - Asbestos Free Warranty

END OF SECTION

SECTION 04 05 00
MORTAR AND GROUT

PART 1 GENERAL

1.1 SUMMARY

- A. Section Includes
 - 1. Provide mortar and grout for replacement masonry.
 - 2. Provide mortar for repointing.

1.2 RELATED DOCUMENTS

- A. Drawings and general provisions of the Contract, including General and Supplementary Conditions, Division 1 Specification Sections and the following Specification Sections apply to this Section:
 - 1. Section 04 05 24 - Masonry Repointing
 - 2. Section 04 20 00 - Unit Masonry

1.3 REFERENCE STANDARDS

- A. ASTM C91/C91M - Standard Specification for Masonry Cement; 2023.
- B. ASTM C144 - Standard Specification for Aggregate for Masonry Mortar; 2018.
- C. ASTM C150/C150M - Standard Specification for Portland Cement; 2022.
- D. ASTM C207 - Standard Specification for Hydrated Lime for Masonry Purposes; 2018.
- E. ASTM C270 - Standard Specification for Mortar for Unit Masonry; 2019a, with Editorial Revision.
- F. ASTM C404 - Standard Specification for Aggregates for Masonry Grout; 2018.
- G. ASTM C476 - Standard Specification for Grout for Masonry; 2023.
- H. ASTM C595/C595M - Standard Specification for Blended Hydraulic Cements; 2021.
- I. ASTM C979/C979M - Standard Specification for Pigments for Integrally Colored Concrete; 2016.

1.4 SUBMITTALS

- A. Product Data: Manufacturer's Product Data Sheets for materials specified certifying material complies with specified requirements.
- B. Manufacturer's Instructions: Latest edition of the Manufacturer's current material specifications and installation instructions.
- C. Samples: Furnish mortar color samples to match existing mortar for acceptance by Engineer and Owner.

1.5 PRODUCT DELIVERY, STORAGE AND HANDLING

- A. Deliver masonry materials in original sealed containers marked with name of manufacturer and identification of contents.
- B. Store masonry materials under waterproof covers on planking clear of ground, and protect damage from handling, dirt, stain, water and wind.

1.6 MORTAR SAMPLING AND TESTING

- A. Sample and submit mortar for testing and analysis by a qualified testing firm to determine mortar mix requirements prior to work.

PART 2 PRODUCTS

2.1 MATERIALS

- A. Portland Cement: ASTM C150/C150M, Type I
- B. Hydrated Lime: ASTM C207 S
- C. Masonry Cements: ASTM C91/C91M, Type N
- D. Sand: ASTM C144
 - 1. Light colored sand for mortar for laying face brick.
 - 2. White plastering sand meeting sieve analysis for mortar joints for pointing and laying of structural facing tile units except that 100 percent passes No. 8 sieve and not more than 5 percent retained on No. 16 sieve.
 - 3. Test sand for color value in accordance with ASTM C40. Sand producing color darker than specified standard is unacceptable.
- E. Grout Aggregate: ASTM C404, Size 8
- F. Admixtures:
 - 1. No air-entraining admixtures or material containing air-entraining admixtures.
 - 2. No antifreeze compounds added.
 - 3. No admixtures containing added.
- G. Water: Clean and potable.
- H. Mortar Pigment:
 - 1. ASTM C979/C979M: Not to exceed ten percent of the weight of Portland cement.
 - 2. Carbon black not to exceed two percent of the weight of Portland cement.
 - 3. Color of mortar to match existing mortar.
- I. Liquid Acrylic Resin: A formulation of acrylic polymers and modifiers in liquid form designed for use as an additive for mortar to improve physical properties.
- J. Blended Hydraulic Cement: ASTM C595/C595M, Type IS, IP, I (PM).

K. Mortar Cement: ASTM C1329, Type N.

2.2 MORTAR AND GROUT MIXES

A. Masonry Mortar: ASTM C270.

B. Grout:

1. Conform to ASTM C476 except as specified.
2. Fine Grout:
 - a. Portland cement or blended hydraulic cement: one part.
 - b. Hydrated lime: 0 to 1/10 part.
 - c. Fine aggregate: 2-1/4 to three times sum of volumes of cement and lime used.
3. Coarse Grout:
 - a. Portland cement or blended hydraulic cement: one part.
 - b. Hydrated lime: 0 to 1/10 part.
 - c. Fine aggregate: 2-1/4 to three times sum of volumes of cement and lime used.
 - d. Coarse aggregate: one to two times sum of volumes of cement and lime used.
4. Sum of volumes of fine and coarse aggregates: Do not exceed four times sum of volumes of cement and lime used.

PART 3 EXECUTION

3.1 MIXING

- A. Mix in a mechanically operated mortar mixer for at least three minutes but not more than five minutes.
- B. Measure ingredients by volume using a container with a known capacity.
- C. Mix water with dry mortar ingredients in sufficient amount to provide a workable mixture which adheres to vertical surfaces of masonry units.
- D. Mix water with grout dry ingredients in sufficient amount to bring grout mixture to a pouring consistency.
- E. Mortar that has stiffened because of loss of water through evaporations:
 1. Re-tempered by adding water to restore to proper consistency and workability.
 2. Discard mortar that has reached its initial set or has not been used within two hours.

3.2 MORTAR USE LOCATION

- A. Use Type N mortar for brick veneer walls above grade, repointing or other masonry work.

3.3 GROUT USE LOCATIONS

- A. Use fine grout for filling wall cavities and cells of concrete masonry units where the smallest dimension is 2 inches (50 mm) or less.
- B. Use coarse grout for filling wall cavities and cells of concrete masonry units where the smallest dimension is greater than 2 inches (50 mm).
- C. Do not use grout for filling bond beam or lintel units.

END OF SECTION

SECTION 04 05 24

MASONRY REPOINTING

PART 1 GENERAL

1.1 SUMMARY

- A. Section Includes
 - 1. Repointing of damaged or deteriorated mortar joints.

1.2 RELATED DOCUMENTS

- A. Drawings and general provisions of the Contract, including General and Supplementary Conditions, Division 1 Specification Sections and the following Specification Sections apply to this Section:
 - 1. Section 04 05 00 - Mortar and Grout

1.3 PROJECT CONDITIONS

- A. Protect newly pointed joints from rain, until pointed joints are sufficiently hard enough to prevent damage.
- B. Cold Weather Protection:
 - 1. Utilize methods of protection when repointing in freezing temperatures.
 - 2. Comply with applicable sections of "Recommended Practices for Cold Weather Construction" as published by International Masonry Industry All Weather Council.
 - 3. Maintain surfaces at temperatures to prevent mortar from freezing or causing other damage to mortar.

PART 2 PRODUCTS

2.1 MATERIALS

- A. Repointing Mortar: Refer to Section 04 05 00 - Mortar and Grout for mortar requirements.

PART 3 EXECUTION

3.1 REMOVAL OF EXISTING MORTAR JOINTS

- A. Cut out existing mortar joints, both bed and head joints, and remove by means of a tooting chisel or a special pointer's grinder, to a uniform depth of 3/4-inch, or until sound mortar is reached. Take care to not damage edges of existing masonry units to remain.
- B. Remove dust and debris from the joints by brushing, blowing with air or rinsing with water. Do not rinse when temperature is below freezing.

3.2 INSTALLATION

- A. Prior to application of mortar, dampen joints and allow masonry units to absorb surface water.

- B. Tightly pack mortar into joints in thin layers, approximately 1/4-inch thick maximum.
- C. Allow layer to become "thumbprint hard" before applying next layer.
- D. Pack final layer flush with surfaces of masonry units. When mortar becomes "thumbprint hard", tool joints.
- E. Tooling of Joints
 - 1. Tool joints with a jointing tool to produce a smooth, compacted, concaved joint.
 - 2. Tool joints in patch work with a jointing tool to match the existing surrounding joints.

3.3 CLEANING

- A. Clean exposed masonry surfaces on completion.
- B. Remove mortar droppings and other foreign substances from wall surfaces.
- C. First wet surfaces with clean water then wash down with a solution of soapless detergent specially prepared for cleaning brick.
- D. Brush with stiff fiber brushes while washing and thereafter hose down with clean water.
- E. Free clean surfaces from traces of detergent, foreign streaks or stains. Protect materials during cleaning operations including adjoining construction.
- F. Use of muriatic acid for cleaning is prohibited.

END OF SECTION

SECTION 04 20 00

UNIT MASONRY

PART 1 GENERAL

1.1 SUMMARY

- A. Section Includes
 - 1. Provide concrete masonry units for the following:
 - a. Replace damaged or deteriorate veneer units.

1.2 RELATED DOCUMENTS

- A. Drawings and general provisions of the Contract, including General and Supplementary Conditions, Division 1 Specification Sections and the following Specification Sections apply to this Section:
 - 1. Section 04 05 00 - Mortar and Grout

1.3 REFERENCE STANDARDS

- A. ASTM C67/C67M - Standard Test Methods for Sampling and Testing Brick and Structural Clay Tile; 2023.
- B. ASTM C90 - Standard Specification for Loadbearing Concrete Masonry Units; 2023.

1.4 SUBMITTALS

- A. Product Data: Manufacturer's Product Data Sheets for materials specified certifying material complies with specified requirements.
- B. Samples: Review Owners existing veneer and match new veneer to existing for Owner approval.

PART 2 PRODUCTS

2.1 CONCRETE MASONRY UNITS

- A. General: Provide shapes indicated and as follows:
 - 1. Provide special shapes for lintels, corners, jambs, sash, control joints, headers, bonding, and other special conditions.
 - 2. Provide square edged units for outside corners, except where indicated as bullnose.
- B. Masonry Unit Types:
 - 1. Hollow Load Bearing Concrete Masonry Units: ASTM C90, Type 1 or 2 as specified above, Grade N-I or N-II, made with lightweight aggregate. Provide load bearing units for exterior walls, foundation walls, load-bearing walls and shear walls.

2. Special Shapes: Provide special shapes, lintels, corners, control joints, closures, header units, jamb units and other special units to complete the work. Provide special shapes conforming to the requirements for the units with which they are used.
 3. Finish: Color and texture to match existing units, verify in field.
 4. Size: Manufactured to the dimensions listed below (within tolerances specified in the applicable referenced ASTM specification) for the corresponding nominal sizes indicated on Drawings.
 - a. 4-inch nominal: 3-5/8
- C. Subject to compliance with the requirements, provide units from a single source.
1. Johnson Concrete
 2. Adams
 3. Metromont
 4. Engineers accepted equivalent

2.2 MORTAR AND GROUT MATERIALS

- A. Refer to Section 04 05 00 - Mortar and Grout.

2.3 MASONRY ANCHORS

- A. Corrugated Buck Anchor: Minimum 16-gauge hot dipped galvanized steel with corrugations, minimum width of 1-1/4 inch and length sufficient to extend no less than 3/4 inch from outside face of veneer.

2.4 MASONRY CLEANER

- A. Submit brick and mortar manufacturer's written acceptance of proposed cleaner.

PART 3 EXECUTION

3.1 EXAMINATION

- A. Examine conditions for compliance with requirements for installation tolerances and other conditions affecting performance.
- B. Prepare written report the listing conditions detrimental to performance.
- C. Verify that foundations are within tolerances specified.
- D. Verify that reinforcing dowels are properly placed.
- E. Proceed with installation only after unsatisfactory conditions have been corrected.

3.2 INSTALLATION

- A. Build cavity and composite walls and other masonry construction to the thickness shown.
- B. Build single-wythe walls to the widths of masonry units, using units of widths indicated.

- C. Cut masonry units with motor-driven saws to provide clean, sharp, unchipped edges. Cut units to provide a continuous pattern and to fit adjoining construction. Where possible, use full-size units without cutting. Install cut units with cut surfaces and, where possible, cut edges concealed.
- D. Select and arrange units for exposed unit masonry to produce a uniform blend of colors and textures. Mix units from several pallets or cubes as they are placed.
- E. Matching Existing Masonry: Match coursing, bonding, color, and texture of existing masonry.
- F. Wetting of Brick: Wet brick before laying if the initial rate of absorption exceeds 30 g/30 sq. in. per minute when tested per ASTM C67/C67M. Allow units to absorb water so they are damp but not wet at the time of laying.

3.3 REPLACEMENT OF MASONRY UNITS

- A. Cut out mortar joints surrounding masonry units being replaced.
 - 1. Units can be broken and removed provided surrounding units to remain are not damaged.
 - 2. Once the units are removed, carefully chisel out the old mortar and remove dust and debris.
 - 3. If units are located in exterior wythe of a cavity or veneer wall, exercise care to prevent debris falling into cavity.
- B. Dampen surfaces of the surrounding units before units are placed.
 - 1. Allow masonry to absorb surface moisture prior to starting installation of the replacement units.
 - 2. Butter contact surfaces of existing masonry and replacement masonry units with mortar.
 - 3. Center replacement masonry units in opening and press into position.
 - 4. Remove excess mortar with a trowel.
 - 5. Point around replacement masonry units to ensure full head and bed joints.
 - 6. When mortar becomes "thumbprint hard", tool joints.

3.4 CONSTRUCTION TOLERANCES

- A. Comply with tolerances in ACI 530.1/ASCE 6/TMS 602 and the following:
- B. For vertical alignment of exposed head joints, do not vary from plumb by more than 1/4 inch in 10 feet, nor 1/2 inch maximum.
- C. For exposed bed and head joints, do not vary from thickness indicated by more than plus or minus 1/8 inch, with a maximum thickness limited to 1/2 inch. Do not vary from adjacent bed-joint and head-joint thicknesses by more than 1/8 inch.

3.5 MORTAR BEDDING AND JOINTING

- A. Lay hollow masonry units as follows:

1. With full mortar coverage on horizontal and vertical face shells.
 2. Bed webs in mortar in starting course on footings and in courses of piers, columns, and pilasters, and where adjacent to cells or cavities to be filled with grout.
 3. For starting course on footings where cells are not grouted, spread out full mortar bed, including areas under cells.
- B. Cut joints flush for masonry walls to receive plaster or other direct-applied finishes (other than paint).

3.6 CAVITIES

- A. Keep cavities clean of mortar droppings and other materials during construction. Strike joints facing cavities flush.
- B. Cavity-Wall Insulation:
1. Place small dabs of adhesive, spaced approximately 12 inches o.c. both ways, on inside face of insulation boards.
 2. Fit courses of insulation between wall ties and other confining obstructions in cavity, with edges butted tightly both ways.
 3. Press units firmly against inside wythe of masonry or other construction.
 4. Fill cracks and open gaps in insulation with additional insulation or minimal-expanding spray foam with a low-pressure build.

3.7 ANCHORING MASONRY VENEERS

- A. Anchor masonry veneers to wall framing with masonry-veneer anchors to comply with the following requirements:
1. Fasten each anchor through sheathing to wall framing/to CMU back-up wall with fasteners provided by anchor manufacturer suitable for back-up wall substrate.
 2. Embed tie sections in masonry joints.
 3. Locate anchor sections to allow maximum vertical differential movement of ties up and down.
 4. Space anchors no more than 18 inches on center vertically and 24 inches on center horizontally, with not less than 1 anchor for each 2 sq. ft. of wall area. Install additional anchors within 8 inches of openings and at intervals, not exceeding 8 inches, around the perimeter.
 5. Provide corrugated buck anchors anchored to the back-up wall spaced at 24 inches on center maximum along the top course of the replacement masonry for the through wall flashing system replacement.

3.8 REPAIR

- A. Remove and replace masonry units that are loose, chipped, broken, stained, or otherwise damaged or that do not match adjoining units. Install units to match adjoining units; install in fresh mortar, pointed to eliminate evidence of replacement.

- B. Pointing: During the tooling of joints, enlarge voids and holes, except weep holes, and fill with mortar. Point up joints, including corners, openings, and adjacent construction, to provide a neat, uniform appearance. Prepare joints for sealant application.

3.9 CLEANING

- A. In-Progress Cleaning: Clean unit masonry as work progresses by dry brushing to remove mortar fins and smears before tooling joints.
- B. Final Cleaning: After mortar is thoroughly set and cured, clean exposed masonry as follows:
 - 1. Remove large mortar particles by hand with wooden paddles and nonmetallic scrape hoes or chisels.
 - 2. Test cleaning methods on sample wall panel; leave one-half of panel uncleaned for comparison purposes. Obtain Engineer's acceptance of sample cleaning before proceeding with cleaning of masonry.
 - 3. Clean brick by the bucket-and-brush hand-cleaning method described in BIA Technical Notes No. 20, using job-mixed detergent solution.
 - 4. Clean concrete masonry by cleaning method indicated in NCMA TEK 8-2 applicable to type of stain on exposed surfaces.

3.10 DISPOSAL

- A. Remove masonry waste and legally dispose.

END OF SECTION

SECTION 07 13 26

SELF-ADHERING SHEET WATERPROOFING

PART 1 GENERAL

1.1 SUMMARY

A. Section Includes:

1. Provide surface preparation and self-adhered, rubberized asphalt sheet membrane waterproofing along with related accessories to repair below grade waterproofing at downspout repair locations.

1.2 RELATED DOCUMENTS

A. Drawings and general provisions of the Contract, including General and Supplementary Conditions, Division 1 Specification Sections and the following Specification Sections, apply to this Section:

1. Section 07 62 00 - Sheet Metal Flashing and Trim
2. Section 31 00 00 – Earthwork

1.3 SUBMITTALS

- A. Product Data: Manufacturer's Product Data Sheets for materials specified certifying material complies with specified requirements.
- B. Manufacturer's Instructions: Latest edition of the Manufacturer's current material specifications and installation instructions.

1.4 REFERENCE STANDARDS

- A. SCAQMD 1168 - Adhesive and Sealant Applications; 1989, with Amendment (2022).

1.5 QUALITY ASSURANCE

- A. Manufacturer: Manufactured by a firm with a minimum of 10 years' experience in the production and sales of self-adhesive sheet membrane waterproofing.
- B. Installer: A firm with at least 3 years' experience in work of the type required by this section.
- C. Materials: Provide primary materials from a single source manufacturer.
- D. Pre-Application Conference: Hold a pre-application conference to establish procedures and to review conditions, installation procedures and coordination with other related work. Include review of special details and flashing during meeting.
- E. Manufacturer's Representative: Arrange to have trained representative of the manufacturer on site periodically to review installation procedures.

1.6 DELIVERY, STORAGE AND HANDLING

- A. Deliver materials to site in manufacturer's original, unopened containers and packaging, with labels clearly identifying product name and manufacturer.

- B. Store materials in a clean, dry area in accordance with manufacturer's instructions.
- C. Store adhesives at temperatures of 40° F (5°C) and above to facilitate handling.
- D. Store membrane cartons on pallets.
- E. Keep away from sparks and flames.
- F. Completely cover when stored outside. Protect from rain.
- G. Protect materials during handling and application to prevent damage or contamination.
- H. materials that may come into contact with waterproofing membrane system.

1.7 PROJECT CONDITIONS

- A. Perform work when current and forecasted weather conditions are within the limits established by the material manufacturer.
 - 1. Do not apply membrane if the temperature is below 25°F (-4°C) or to a damp, frost covered, or otherwise contaminated surface.
- B. Proceed with installation when substrate construction and preparation work is complete and in condition to receive sheet membrane waterproofing.
- C. Warn personnel against breathing of vapors and contact with skin and eyes; wear appropriate protective clothing and respiratory equipment.
- D. Keep flammable products away from spark or flame. Post "No Smoking" signs. Do not allow use of spark-producing equipment during application and until all vapors have dissipated.
- E. Maintain work area in a neat and workmanlike condition. Remove empty cartons and rubbish from the site daily.

PART 2 PRODUCTS

2.1 MATERIALS

- A. Sheet Membrane Waterproofing: Self-adhering, cold-applied composite sheet consisting of a nominal 60-mil thickness with 56 mil of rubberized asphalt and 4 mil of cross-laminated, high density polyethylene film per ASTM D3767.
 - 1. Polyguard 650 Membrane as manufactured by Polyguard Products, Inc.
 - 2. MAPETHENE HT Membrane as manufactured by MAPEI.
 - 3. BITUTHENE 3000 Membrane as manufactured by GCP Applied Technologies.
 - 4. MEL-ROL Membrane as manufactured by W.R. Meadows, Inc.
 - 5. MiraDRI 860/861 as manufactured by Carlisle Coatings & Waterproofing Inc.

2.2 RELATED MATERIALS

- A. Surface Primer Roller-grade Adhesive:
 - 1. Liquid Adhesive:

- a. A rubber-based, tacky adhesive which is specifically formulated to provide excellent adhesion.
 - b. A water-based, rubber-based adhesive which is specifically formulated to provide excellent adhesion.
- 2. Sealant: A rubber-based sealant which is specifically formulated to provide excellent adhesion. The VOC (Volatile Organic Compound) content meets the SCAQMD 1168 less than 775 g/L.
- B. Detail Tape: Rubberized-asphalt waterproofing membrane laminated to polypropylene backing. The membrane is wound onto a disposable, silicone-treated release sheet to prevent the membrane from sticking onto itself while in the roll. Use Detail Tape for inside/outside corners, penetrations, patching damaged areas and transitions.
- C. Liquid Membranes:
 - 1. Semi-Self-Leveling Liquid Membrane: A two-component, semi-self-leveling, asphalt-modified, urethane material.
 - 2. Liquid Membrane: A two-component, asphalt-modified, urethane.
- D. Detail Sealant: A single-component, STPE, 100% solid moisture-cured, elastomeric sealant. It is an environmentally friendly, non-isocyanate product that replaces silicone and urethane sealants. It is also a low VOC / HAPS-free, cold-applied, self-adhesive, elastomeric sealant.
- E. Miscellaneous Materials: Surface conditioner, waterstop, primer, mastic, liquid membrane, tape, adhesives and other accessories specified or acceptable to manufacturer of sheet membrane waterproofing.

2.3 ACCESSORIES

- A. Termination Bar: Extruded 1 inch x 1/8 inch aluminum bar with holes pre-punched at 6 inches on center.
 - 1. Fasteners: 1/4 inch diameter metal-based expansion anchor with stainless steel pin of length to penetrate substrate a minimum of 1-1/2 inch.

PART 3 EXECUTION

3.1 EXAMINATION

- A. Examine conditions of substrates and other conditions and notify the Engineer, in writing, of circumstances detrimental to the proper completion of the work. Do not proceed with work until unsatisfactory conditions are corrected.

3.2 PREPARATION

- A. Refer to manufacturer's literature for requirements for preparation of substrates. Surfaces structurally sound and free of voids, spalled areas, loose aggregate and sharp protrusions. Remove contaminants, grease, oil and wax from exposed surfaces. Remove dust, dirt, loose stone and debris. Use repair materials and methods acceptable to manufacturer of sheet membrane waterproofing.
- B. Cast-In-Place Concrete Substrates:

1. Do not proceed with installation until concrete has properly cured and dried minimum 7 days for normal structural concrete and minimum 14 days for lightweight structural concrete.
 2. Fill form tie rod holes with concrete and finish flush with surrounding surface.
 3. Repair bugholes over 1/2 inch long and 1/4 inch deep and finish flush with surrounding surface.
 4. Remove scaling to sound, unaffected concrete and repair exposed area.
 5. Grind irregular construction joints to suitable flush surface.
- C. Masonry Substrates: Apply waterproofing over concrete block and brick with smooth trowel-cut mortar joints or parge coat.
- D. Treat joints and install flashing as recommended by waterproofing manufacturer.

3.3 INSTALLATION

- A. Refer to manufacturer's literature for recommendations on installation, including but not limited to, the following:
1. Apply primer at rate recommended by manufacturer. Recoat areas not waterproofed if contaminated by dust. Mask and protect adjoining exposed finish surfaces to protect those surfaces from excessive application of primer.
 2. Delay application of membrane until wall substrate and primer are dry. Dry time varies with weather conditions.
 3. Install patches prior to backfilling.
 4. Install cant bead where patch meets the footer.
 5. Install Sheet Membrane Waterproofing in straight lines avoiding wrinkles. Roll membrane in to ensure adhesion.
 6. Seal edges as required by the manufacturer.
 7. Install Termination Bar at the top edge of the Sheet Membrane Waterproofing.

3.4 REPAIRS

- A. Inspect for damage just prior to installation of subsequent construction activities and make repairs in accordance with manufacturer's recommendation.

3.5 PROTECTION

- A. Protect completed membrane waterproofing from subsequent construction activities as recommended by manufacturer.

END OF SECTION

SECTION 07 62 00

SHEET METAL FLASHING AND TRIM

PART 1 GENERAL

1.1 SUMMARY

- A. Section Includes
 - 1. Sheet metal flashings and trim to provide a permanently watertight condition.
 - 2. Precast concrete splash block where temporary downspouts discharge to grade.

1.2 RELATED DOCUMENTS

- A. Drawings and general provisions of the Contract, including General and Supplementary Conditions, Division 1 Specification Sections apply to this Section.

1.3 REFERENCE STANDARDS

- A. ANSI/SPRI/FM 4435/ES-1 - Test Standard for Edge Systems Used with Low Slope Roofing Systems; 2022.
- B. NRCA (RM) - The NRCA Roofing Manual; 2024.
- C. SMACNA (ASMM) - Architectural Sheet Metal Manual; 2012.

1.4 SUBMITTALS

- A. Product Data: Manufacturer's Product Data Sheets for materials specified certifying material complies with specified requirements.
- B. Manufacturer's Instructions: Latest edition of the Manufacturer's current material specifications and installation instructions.
- C. Shop Drawings: For any transitions and/or terminations not depicted in Contract Drawings.

1.5 QUALITY ASSURANCE

- A. Install in accordance with the Contract Drawings.
- B. Ensure work is free of leaks.
- C. Provide metal edge and coping fabricated and tested in accordance with ANSI/SPRI/FM 4435/ES-1 to resist the specified wind uplift pressures.
 - 1. Fabricate metal edge and coping as shown in Contract Drawings and following NRCA (RM) tested details.
- D. Provide sheet metal flashing and trim in accordance with SMACNA (ASMM).
- E. Provide first-class workmanship. Assemble and secure sheet metal work in accordance with these specifications, roof system manufacturer's requirements and referenced standards.

1.6 DELIVERY, STORAGE AND HANDLING

- A. Delivery: Deliver materials in the manufacturer's original sealed and labeled containers and in quantities required to allow continuity of application.
- B. Storage: Store materials within areas designated by the Owner. Ensure materials remain dry, covered and not in contact with the ground.
- C. Handling: Handle material in such manner as to preclude damage and contamination with moisture or foreign matter.

1.7 PROJECT CONDITIONS

- A. Environmental: Protect building and its components from the elements.
- B. Coordination and Scheduling: Coordinate phases of work to allow continuity of work without delays.

1.8 WARRANTY

- A. Provide pre-finished sheet metal manufacturer's thirty (30) year finish warranty from the date of substantial completion.

PART 2 PRODUCTS

2.1 PRIMARY SHEET METAL

- A. Material: Pre-finished Galvalume
 - 1. 24-gauge, galvalume coated steel meeting or exceeding AZ50 per ASTM A792. Manufacturer's smooth finish, pre-finished color coatings consisting of 70% Kynar 500 fluorocarbon (Polyvinylidene Fluoride PVF2) coating over a urethane primer on the finish side, with primer and a wash coat on the reverse. Measurements per NCCA Technical Bulletin II-4 or ASTM D1005. Protect the finish during fabrication and installation with a strippable plastic film. Manufacturer's standard color selected by Owner.
- B. Components:
 - 1. Downspout Strap
 - 2. Outlet Tube

2.2 FASTENERS

- A. Screws:
 - 1. Sheet metal to sheet metal attachment (exposed): 1/4 inch x 7/8 inch carbon steel, self-drilling point, self-tapping, zinc alloy hex head screws with bonded EPDM tubular washer under head of fastener; screw heads to match color of wall panel by means of factory applied coating. Factory painted heads to match the sheet metal color.
- B. Concrete and Masonry Anchors: 1/4 inch diameter metal-based expansion anchor with stainless steel pin of length to penetrate substrate a minimum of 1-1/2 inches. Factory painted heads to match the sheet metal color.
- C. Washers: Stainless steel with neoprene gasket backing.

1. 5/8 inch diameter for use with 1/4 inch diameter concrete and masonry anchors.
- D. Rivets: #44 stainless steel rivets with stainless steel mandrel and factory painted head to match adjacent sheet metal. Length to properly fasten particular sheet metal components.

2.3 RELATED MATERIALS

- A. Sealants:
1. Sealant Tape: Minimum 1/2 inch wide, non-skinning, butyl sealant tape.
 2. Butyl Sealant: Gun grade, non-skinning, non-hardening, flexible blend of butyl rubber and polyisobutylene sealant.
- B. Pre-Cast Concrete Splash Block: Premanufactured 36 inch by 3 inch by 12 inch, heavy duty concrete splash block.

PART 3 EXECUTION

3.1 EXAMINATION

- A. Coordinate with other work for correct sequencing of items.
- B. Ensure substrates are installed, secured and modified to accommodate sheet metal flashings.
- C. Report deficiencies associated with the sheet metal substrates to Engineer before beginning sheet metal work. Correct deficiencies before installing sheet metal flashings.

3.2 INSTALLATION

- A. General:
1. Lock and seal joints of pre-finished sheet metal.
 2. Provide uniform sheet metal sections with corners, joints and angles mitered, sealed and secured.
 3. Hem (return) exposed edges for strength and appearance.
 4. Fit sheet metal close and neat.
 5. Provide cleats or stiffeners and other reinforcements to make sections rigid and substantial.
 6. Fabricate, support, cleat, fasten and join sheet metal to prevent warping, "oil canning", and buckling.
- B. Sheet Metal Laps (unless otherwise indicated):
1. Notch and lap ends of adjoining sheet metal sections not less than 4 inches; apply sealant tape or two bead of butyl sealant between sections.
 2. Lap miters at corners a minimum of 1 inch and apply sealant between laps. Rivet at 2 inches on center.
- C. Fasteners:

1. Size and type required.
 2. Fasteners compatible with materials being joined.
 3. Exposed Fasteners:
 - a. Install Concrete and Masonry Anchors with 11/32-inch predrilled, oversized holes.
- D. Gutters:
1. Provide downspout outlet tubes in downspout locations. Refer to SMACNA (ASMM) Figure 1-33B and Detail 1. Tab gutter outlet tubes a minimum of 1 inch, set in a bead of sealant and secure to gutter with a minimum of two rivets per tab.
- E. Downspouts:
1. Fabricate downspouts from 4-inch diameter schedule 40 PVC.
 2. Secure downspout to the structure with hangers spaced no more than 5 feet apart with a minimum of two hangers per downspout with a hanger located within 12 inches from bottom.
 3. Fashion downspouts to run back to (at overhangs) and be parallel to the facility walls.
 4. Tie downspouts into below grade storm drainage system unless otherwise noted on Drawings.
 - a. Provide cast iron downspout boot as specified.
 5. If below grade storm drainage system is not present, kick-out downspouts above grade onto concrete splash blocks. Fill in soil to provide slope away from building.

3.3 CLEANING AND PROTECTION

- A. Clean sheet metal work of asphalt, flux, scrapes and dust.
- B. Replace sheet metal components with scratches through the metal finish.

END OF SECTION

SECTION 07 92 00

ELASTOMERIC JOINT SEALANTS

PART 1 GENERAL

1.1 SUMMARY

- A. Section Includes:
 - 1. Replace joint sealants to include removal of materials, preparation of joints, priming of substrate as determined from sample adhesion tests, installation of backer-rod or tape to prevent 3-sided adhesion, and providing specified sealant properly tooled to ensure adhesion.

1.2 RELATED DOCUMENTS

- A. Drawings and general provisions of the Contract, including General and Supplementary Conditions, Division 1 Specification Sections and the following Specification Sections, apply to this Section:
 - 1. Section 04 05 00 - Mortar and Grout
 - 2. Section 04 20 00 - Unit Masonry

1.3 REFERENCE STANDARDS

- A. ASTM C920 - Standard Specification for Elastomeric Joint Sealants; 2018.
- B. ASTM C1193 - Standard Guide for Use of Joint Sealants; 2016 (Reapproved 2023).
- C. ASTM C1248 - Standard Test Method for Staining of Porous Substrate by Joint Sealants; 2022.

1.4 SUBMITTALS

- A. Product Data: Manufacturer's Product Data Sheets for materials specified certifying material complies with specified requirements.
- B. Manufacturer's Instructions: Latest edition of the Manufacturer's current material specifications and installation instructions.
- C. Samples for Verification: Provide Manufacturer's standard color selection for Owner's approval. Provide physical sample of preselected color(s) for final approval of color by Owner before installation.
- D. Compatibility and Adhesion Test Reports: Submit Manufacturer's letters indicating substrate samples have been tested for adhesion and compatibility. Include surface preparation methods along with primer requirements for the substrates tested.
- E. Non-Stain Testing: Provide certification for silicone joint sealants indicating completion of stain testing in compliance with ASTM C1248 for non-fluid-staining results on porous surfaces, concrete, granite and marble.

1.5 QUALITY ASSURANCE

- A. Installer Qualifications:

1. Minimum of 5 years successful experience in building envelope restoration with the application of elastomeric joint sealants on projects of similar type and nature.
 2. Approved by Sealant Manufacturer.
- B. Manufacturer's Field Services: During construction and until substantial completion, perform monthly quality assurance site visits by manufacturer's technical representative to ensure materials are being properly installed and as required to obtain the specified warranty.
1. Manufacturer present during the field mock-up phase and testing.
 2. Coordinate site visits with Engineer. Submit reports of findings within one week of inspection. Payment applications will be rejected until applicable reports are received.
 3. Inspections to be performed by an employee of the selected manufacturer that is assigned full time to their technical services department. Sales personnel are not acceptable for this function.
 4. Manufacturer's final inspections performed only with REI personnel in attendance. A minimum of seven days' written notice is required. Repeat manufacturer's final inspection conducted without REI personnel in attendance at no additional cost to the Owner.
- C. Source Limitations: Obtain joint sealants, related structural glazing sealant or related elastomeric coatings and joint sealant primers through one source from a single Manufacturer.
- D. Field Mock-up:
1. Before caulking work begins, prepare for caulking three 3 joints, each approximately 48 inches long, in each type material to be caulked. Treat joints as hereinafter specified as to preparation. After the joint preparation has been observed by the Engineer, Sealant Manufacturer, and the Contractor, caulk the joints and allow to reach final cure.
 2. After final cure, obtain samples and test for appropriateness of preparation, installation and for adhesion of sealant to substrate. Test completed by manufacturer.
 3. After the manufacturer's representative has observed the on-site job preparation and sealant application for the test areas, and after the material has been tested for appropriateness of use and field condition compliance with the specifications, present to the Engineer a certification that the sealant material is in compliance with the specifications and that field conditions tests confirm that the sealant material is appropriate and suitable for the intended use. Completed by manufacturer.
 4. Do not begin work on the project until approved field tests have been accepted by the Engineer.
- E. During the progress of the work, after material has received final cure, hand pull test in accordance with procedures as published by SWRI, perform in the presence of the Engineer. Perform tests at random times in random areas selected by the Engineer. Repair test areas at no additional charge to the owner.

1.6 DELIVERY, STORAGE, AND HANDLING

- A. Delivery: Deliver materials in the manufacturer's original sealed and labeled containers and cartons.
- B. Storage. Store materials out of direct exposure to the elements, located above standing water at least 4 inches above ground level. Place non-sweating tarpaulins to prevent moisture contamination.
- C. Sealants are heat and moisture sensitive; protect from excessive heat exposure and moisture exposure.
- D. Do not allow sealants to be exposed to prolonged freezing temperatures.
- E. Shelf Life: Do not use products over 9 months old unless Manufacturer's published literature allow. Document product self-life information, and check expiration date before use.
- F. Handling: Handle material to prevent exposure to moisture. During cold temperatures (less than 40°F) store containers at room temperature for 24 hours.

1.7 PROJECT CONDITIONS

- A. Do not apply sealant during precipitation or start in the event there is a probability of precipitation during the application. Forecasted conditions to be dry for no less than 24 hours after application
- B. Ensure sealant Manufacturer's published requirements are followed, including the following general limitations for sealants:
 - 1. Do not apply polyurethane sealants to uncured silicone sealants, or install adjacent to uncured silicone.
 - 2. Do not allow uncured polyurethane sealant to come in contact with alcohol-based sealants, butyl sealants, acrylic sealants or other incompatible materials.
 - 3. Do not allow uncured polyurethane sealant to come in contact with oil-based caulking/sealants, oil, asphalt, polysulfides, or fillers impregnated with oil, asphalt or tar.
 - 4. Do not install sealant on damp substrates.
 - 5. Do not install where sealant where continually immersed in water.
 - 6. Do not apply sealant to "green" treated lumber.
 - 7. Prime masonry, stainless steel, copper, galvanized steel and pre-finished metal with sealant Manufacturer's approved primer. Refer to specified primers.
 - 8. Follow Manufacturer's published precautions.
- C. Do not install more sealant than can cure for 24 hours before precipitation.

1.8 WARRANTY

- A. Material Manufacturer's Warranty:

1. Guarantee material to meet or to exceed the properties specified within this section of the specifications and agree to replace products found defective.
2. Silicone Sealant: 20 year period beginning at date of substantial completion of the work.

PART 2 PRODUCTS

2.1 MATERIALS

A. Silicone Sealant Components:

1. Silicone Sealant: One-component, non-sag, neutral cure, low-modulus, UV resistant, high performance silicone sealant for high movement expansions and control joints meeting AASTM C920, Type S, Grade NS, Class 100/50, Use NT, M, G, A or O. Color chosen by Owner from manufacturer's standard color chart and approved by Owner in advance of application. Acceptable Manufacturers include:
 - a. Dow 790 Building Sealant
 - b. Pecora 890 NST Silicone
 - c. Sikasil-WS 290
 - d. Tremco Spectrum 1
 - e. GE Silicone SilPruf SCS2700 LM
2. Silicone Sealant (Glazing): One-component, non-sag, neutral cure, low-modulus, UV resistant, high performance silicone sealant for high movement expansions and control joints meeting ASTM C920, Type S, Grade NS, Class 50, Use NT, M, G, A or O. Color chosen by Owner from manufacturer's standard color chart and approved by Owner in advance of application. Acceptable Manufacturers include:
 - a. Dow 795 Building Sealant
 - b. Pecora 895 NST Silicone
 - c. Sikasil-WS 295
 - d. Tremco Spectrum 2
 - e. GE Silicone SilPruf SCS2000
3. Primer: Primer manufactured and recommended by Sealant Manufacturer. Consult sealant Manufacturer's published literature for specific substrate and primer types.
4. Backer Rod: Open-cell polyurethane backer-rod or soft polyethylene backer-rod as recommended by sealant Manufacture sized 25% greater than joint for tight fitting compression in the joint.
5. Bond-breaker Tape: Polyethylene strip or tape, as recommended by or supplied by the sealant Manufacturer to prevent 3-sided bond in joints.

PART 3 EXECUTION

3.1 EXAMINATION

- A. Site Verification of Conditions: Inspect joints indicated for restoration and verify joint substrate conditions are acceptable for installation in accordance with sealant Manufacturer's instructions. Correct unsatisfactory conditions before installing sealants.
 - 1. Determine acceptable removal techniques for contaminants, dust, dirt, grease, oils, curing compounds, form release agents, laitance and waterproofing film or over-spray coatings which are harmful to sealant performance.
 - 2. Surface Defects and Repairs: Identify contaminants in substrates that are harmful to system performance. Allow substrates or repaired surface defects to cure per manufacturer's recommendations.
- B. Commencement of work signifies acceptance of substrate. Correct defects in work resulting from accepted substrates at no additional expense to the Owner.

3.2 PREPARATION

- A. Protect adjacent work areas and finished surfaces from damage during joint sealant installation.
- B. Prior to installation, remove joint sealant materials and clean substrates of substances that impair the bond of joint sealants. Remove joint sealant residue.
- C. Remove rusting or scaling surfaces using abrasive cleaning methods as recommended by joint sealant Manufacturer prior to joint sealant installation.
- D. Remove and neutralize efflorescence, mold, mildew and algae prior to joint sealant installation.
- E. Clean and prepare joint surfaces before installing joint sealants. Clean and dry surfaces of frost and dust.
 - 1. Clean porous joint surfaces by using heavy-duty brushing, light abrasive, mechanical abrading or combination of these methods to produce a clean, sound surface for optimum bond with joint sealants per manufacturer's recommendations. Provide dry, dust-free and cleaned substrate for optimum results.
 - 2. Clean non-porous surfaces using the two-cloth solvent wipe method as referenced in ASTM C1193 and outlined by joint sealant manufacturer's instruction. IPA (isopropyl alcohol) is not a degreasing solvent; utilize for non-porous joint cleaning and preparation. Use xylene, toluene or MEK for degreasing solvent and general cleaning of non-porous surfaces. Follow applicable precautions associated with solvents.
- F. Coordinate cleaning, priming and installation to avoid contamination of wet, freshly coated or on adjacent finished surfaces.
- G. Prepare finish-coated surfaces in accordance with joint sealant Manufacturer's specific recommendations.

3.3 INSTALLATION

- A. Comply with joint sealant Manufacturer's written installation instructions for products, primers and applications.
- B. Mix two components per manufacturer's recommendations.
- C. Apply joint sealants for continuous waterproof sealant joint protection. Lap vertical joints over horizontal joints as recommended by sealant Manufacturer. Comply with installation recommendations in ASTM C1193 for use of joint sealants as applicable to each specific sealant installation.
- D. Install sealant primers when recommended by sealant Manufacturer and demonstrated at pre-construction tests after joint surface preparation has been completed and when surfaces are verified as clean and dry.
 - 1. Apply sealant Manufacturer's primer per Manufacturer's instructions.
 - 2. Follow Manufacturer's specific safety, health and environmental recommendations per most recent Material Safety Data Sheets, technical bulletins and instructions. Handle solvents in compliance with applicable EPA, OSHA and VOC requirements regarding health/safety standards.
 - 3. Allow primer installation to dry or cure prior to installation of backing or joint sealants.
- E. Install joint sealant backings of type and size required.
 - 1. Avoid gaps, twisting, stretching or puncturing joint sealant backing materials. Place backing materials into joint opening using a gauge or roller-tool designed to provide the appropriate uniform depth allowing optimum sealant profile, sealant coverage and long-term joint sealant performance.
 - 2. Install bond-breaker tape behind sealant joints where sealant backings are not feasible and to avoid 3-sided adhesion at backside of sealant joint.
 - 3. Use masking tape to protect adjacent finished surfaces prior to joint sealant installation.
- F. Install joint sealants in accordance with joint sealant Manufacturer's instructions using proven techniques that comply with the following and in proper sequence with installation of joint backings.
 - 1. Using proper joint sealant dispensing equipment, place sealants by pushing sealant beads into opening to wet-out joint sealant substrates. Fill sealant joint opening to proper configuration.
 - 2. Install, providing uniform cross-sectional shapes and depths in relation to joint width for optimum sealant movement capability per joint sealant manufacturer's instructions.
- G. Tool non-sag joint sealant installations. After placing fresh sealants and before skinning or curing begins, tool sealants using metal spatulas designed for this purpose in accordance with sealant Manufacturer's recommendation. Tool to form a smooth, uniform sealant finish, eliminating air pockets and ensuring good contact for optimum joint sealant adhesion within each side of the joint opening.

1. Provide concave joint configuration as indicated per figure 8-A in ASTM C1193 unless otherwise indicated for the project. Wet tooling of joint sealants is not permitted.
 2. Remove excess sealant from surfaces adjacent to joint openings using metal spatula, promptly cleaning sealant residue from adjacent finished surfaces. Remove masking after joint sealant is installed.
- H. Allow joint sealants to cure for a minimum of 7 days before adhesion testing is performed as recommended by joint sealant Manufacturer for field-testing.
- I. Match approved sealant mock-up for color, finish and overall aesthetics. Remove, refinish or re-install work not in compliance with the Contract Documents.

3.4 FIELD QUALITY CONTROL

- A. Where required above, ensure Manufacturer's field service is provided consisting of site visits at the start of the project, during application, and upon completion of the project.
- B. Field-Adhesion Testing: keep daily log of sealant installation recording self-performed field-adhesion testing at each elevation of the project and as follows:
1. Document and perform field-adhesion testing in accordance with Manufacturer's recommended field-adhesion testing to qualify for joint sealant Manufacturer's Warranty.
 2. Perform 5 field-adhesion tests for the first 1000 lineal feet and one test in each 1000 lineal feet of sealant joint length thereafter. When the sealant is used to weatherseal between two (2) dissimilar substrates, individually test the sealant adhesion to each side of the joint.
 3. Field test joint sealants in accordance with Method A, Field-Applied Sealant Joint Hand-Pull Tab, in Appendix X-1 in ASTM C1193 and in compliance with Manufacturer's specific recommendations.
 4. In compliance with joint sealant manufacturer, joint sealants tested and not indicating adhesive failure within the substrates are considered satisfactory results. For joint sealants that fail to adhere to the substrate, clean, re-install and then re-test until satisfactory results are obtained.
- C. The Engineer and Owner reserves the right to complete recommended testing required by the Manufacturer at completion of work to ensure warranty requirements and contract compliance are met.

3.5 PROTECTION

- A. Protect installed sealants during and after final curing from damage resulting during construction. Replace damaged joint sealants.

3.6 CLEANING

- A. Clean off/remove excess sealant or sealant residue adjacent to joint sealant installations as the work progresses by methods approved by joint sealant Manufacturer. Do not damage adjacent surfaces with harmful removal techniques and protect finished surfaces beyond those that have been masked.

- B. Remove temporary coverings and masking protection from adjacent work areas upon completion. Remove construction debris from the project site on a planned and regular basis.

END OF SECTION

SECTION 22 14 00

STORM DRAINAGE

PART 1 GENERAL

1.1 SUMMARY

- A. Section Includes:
 - 1. Provide exterior, below-grade storm drainage system.

1.2 RELATED DOCUMENTS

- A. Drawings and general provisions of the Contract, including General and Supplementary Conditions and Division 1 Specifications sections apply to this section, including but not limited to:
 - 1. Section 31 00 00 - Earthwork
 - 2. Section 32 05 23 - Cement and Concrete for Exterior Improvements

1.3 REFERENCE STANDARDS

- A. ASTM D1784 - Standard Classification System and Basis for Specification for Rigid Poly(Vinyl Chloride) (PVC) Compounds and Chlorinated Poly(Vinyl Chloride) (CPVC) Compounds; 2020.
- B. ASTM D1785 - Standard Specification for Poly(Vinyl Chloride) (PVC) Plastic Pipe, Schedules 40, 80, and 120; 2021a.
- C. ASTM D2564 - Standard Specification for Solvent Cements for Poly(Vinyl Chloride) (PVC) Plastic Piping Systems; 2020.
- D. ASTM D2665 - Standard Specification for Poly(Vinyl Chloride) (PVC) Plastic Drain, Waste, and Vent Pipe and Fittings; 2020.
- E. ASTM F656 - Standard Specification for Primers for Use in Solvent Cement Joints of Poly(Vinyl Chloride) (PVC) Plastic Pipe and Fittings; 2021.

1.4 SUBMITTALS

- A. Product Data: Manufacturer's Product Data Sheets for materials specified certifying material complies with specified requirements.
- B. Manufacturer's Instructions: Latest edition of the Manufacturer's current material specifications and installation instructions.
- C. Shop Drawings: Include plans, elevations, sections and details.

1.5 QUALITY ASSURANCE

- A. Ensure plumbing systems and components are installed by licensed, qualified personnel.

- B. Ensure roof drains, couplings, piping, supports, fixtures, pipe hangers, fasteners, fittings, etc. are installed in compliance with the referenced plumbing code, and installed in accordance with the component manufacturer's published guidelines and instructions, and referenced standards.
- C. Field test completed storm drain systems as required by the referenced plumbing code.
- D. Prior to excavating, contact local utility locator to pinpoint gas and utility lines.

1.6 DELIVERY, STORAGE AND HANDLING

- A. Delivery: Deliver materials in the manufacturer's original sealed and labeled packaging.
- B. Storage: Store materials to prevent damage and not encumber Owner's operations.
- C. Handling: Handle materials in such a manner as to prevent damage and contamination.

1.7 PROJECT CONDITIONS

- A. Environmental Requirements:
 1. Install roof drains and associated plumbing during periods of no precipitation to prevent water from entering the building.
 2. Prevent damage to the building and contents during drain and associated plumbing installations.
 3. Comply with applicable rules and regulations of Authorities Having Jurisdiction pertaining to storm sewage systems.
- B. Protection:
 1. Ensure drainage systems remain in service and restore to operational before leaving the site.
 2. Repair drain piping clogged by construction debris at no cost to the Owner.
 3. Protect building interior and exterior surfaces during construction.

PART 2 PRODUCTS

2.1 MATERIALS

- A. Below Grade PVC Drainage Pipe:
 1. Manufactured from PVC compound with a cell class of 12454 per ASTM D1784 and conform to National Sanitation Foundation (NSF) Standard 14.
 2. PVC schedule 40: iron pipe size (IPS) conforming to ASTM D1785 and ASTM D2665 .
 3. Fittings conform to ASTM D2665.
 4. Pipe and fittings produced by a single manufacturer and installed in accordance with manufacturer's recommendations and local code requirements.
 5. Solvent cements conform to ASTM D2564

6. Primer conform to ASTM F656.
 7. The system is intended for non-pressure drainage applications where the temperature does not exceed 140°F.
- B. Downspout Boot:
1. Cast iron downspout boot with integral cleanout, 5 inch by 4 inch inlet size and 6 inch diameter outlet size (verify existing system dimension in field). Provide no-hub connection to below grade storm drainage system.
 2. Masonry screws, 1/4-inch minimum diameter, Type 410 stainless steel. Length as required to provide minimum 1 inch embedment into substrate, or as required by the fastener manufacturer to achieve required withdrawal load; provide stainless steel flat washer as necessary. Acceptable manufacturers include:
 - a. Tapcon by ITW Buildex
 - b. KWIK-CON II by Hilti
 - c. Engineers accepted equivalent.

PART 3 EXECUTION

3.1 EXAMINATION

- A. Conduct a pre-job conference including the Engineer, Contractor, and the Owner's representative prior to the installation of roof drains and associated piping and plumbing fixtures.
- B. Verify that conditions are acceptable to begin the installation.
- C. Inspect daily the plumbing installation to ensure conditions remain satisfactory.

3.2 PREPARATION

- A. Inspect building components and conditions before proceeding with plumbing installation.
- B. Inspect the piping route to ensure conditions are satisfactory to install piping and associated plumbing fixtures for the completed drainage system.
- C. Route piping to maintain working spaces around electrical equipment by NEC.
- D. Route piping and fixtures to not interfere with the service of in-place equipment and systems.
- E. Do not close off or obstruct streets, walks or other adjacent occupied facilities without permission from Owner, Engineer, and Authorities Having Jurisdiction. Coordinate with the Owner and Engineer prior to cutting into asphalt pavement, concrete walks or driveways. Return paving, sidewalks, and landscaping to original condition.

3.3 BELOW GRADE PIPING INSTALLATION

- A. Conform to local plumbing, building, fire code requirements and manufacturers recommendations.

- B. General Locations and Arrangements: Drawing plans and details indicate general location and arrangement of underground storm drainage piping. Location and arrangement of piping layout take design considerations into account. Install piping as indicated on Contract Drawings.
 - 1. Install piping a minimum of 24 inches below grade.
- C. Install piping beginning at low point, true to grades and alignment indicated with unbroken continuity of invert. Place bell ends of piping facing upstream.
 - 1. Provide system with minimum 2-percent slope for horizontal piping.
- D. Install gaskets, seals, sleeves, and couplings according to manufacturer's written instructions for use of lubricants, cements, and other installation requirements.
- E. Install fittings for changes in direction. Use fittings for branch connections unless direct tap into existing drainage lines is indicated.
- F. Ensure piping is supported by compacted soil and provide equal compaction on each side of the piping.
- G. Provide a 50/50 mixture of Class II and Class III soil compacted to 95% proctor density.
- H. Apply grass seeding and ground cover to protect area from erosion.

3.4 FIELD QUALITY CONTROL

- A. Inspect interior of piping to determine whether line displacement or other damage has occurred. Inspect after approximately 24 inches of backfill is in place, and again at completion of the Project.
 - 1. Submit separate reports for each system inspection.
 - 2. Defects requiring correction include the following:
 - a. Alignment: Less than full diameter of inside of pipe is visible between structures.
 - b. Deflection: Flexible piping with deflection that prevents passage of ball of cylinder of size not less than 92.5 percent of piping diameter.
 - c. Crushed, broken, cracked or otherwise damaged piping.
 - d. Infiltration: Water leakage into piping.
 - e. Exfiltration: Water leakage from or around piping on watertight joints.
 - 3. Replace defective piping and repeat inspections.
 - 4. Reinspect and repeat procedure until results are satisfactory.

3.5 CLEANING

- A. Clean interior of piping of dirt and superfluous materials. Flush with potable water.

END OF SECTION

SECTION 31 00 00

EARTHWORK

PART 1 GENERAL

1.1 SUMMARY

- A. Section Includes:
 - 1. Excavate and/or backfill to accommodate the installation of flexible or rigid pavement system.

1.2 RELATED DOCUMENTS

- A. Drawings and general provisions of the Contract, including General and Supplementary Conditions, Division 1 Specification Sections and the following Specification Sections apply to this Section:
 - 1. Section 32 05 23 - Cement and Concrete for Exterior Improvements

1.3 REFERENCE STANDARDS

- A. ASTM D698 - Standard Test Methods for Laboratory Compaction Characteristics of Soil Using Standard Effort (12,400 ft-lbf/ft³ (600 kN-m/m³)); 2012 (Reapproved 2021).
- B. ASTM D1556/D1556M - Standard Test Method for Density and Unit Weight of Soil in Place by Sand-Cone Method; 2015, with Editorial Revision (2016).
- C. ASTM D1557 - Standard Test Methods for Laboratory Compaction Characteristics of Soil Using Modified Effort (56,000 ft-lbf/ft³ (2,700 kN-m/m³)); 2012 (Reapproved 2021).
- D. ASTM D2167 - Standard Test Method for Density and Unit Weight of Soil in Place by the Rubber Balloon Method; 2015.
- E. ASTM D2487 - Standard Practice for Classification of Soils for Engineering Purposes (Unified Soil Classification System); 2017, with Editorial Revision (2020).
- F. ASTM D2940/D2940M - Standard Specification for Graded Aggregate Material for Bases or Subbases for Highways or Airports; 2020.

1.4 DEFINITIONS

- A. Backfill: Soil materials used to fill an excavation.
 - 1. Initial Backfill: Backfill placed beside and over pipe in a trench, including haunches to support sides of pipe.
 - 2. Final Backfill: Backfill placed over initial backfill to fill a trench.
- B. Aggregate Base Course (ABC Stone): Well graded stone measuring up to 1 ½" in size.
- C. Bedding Course: Layer placed over the excavated subgrade in a trench before laying pipe.
- D. Borrow: Satisfactory soil imported from off-site for use as fill or backfill.

- E. Drainage Course: Layer supporting slab-on-grade used to minimize capillary flow of pore water.
- F. Excavation: Removal of material encountered above subgrade elevations.
 - 1. Additional Excavation: Excavation below subgrade elevations as directed by Engineer. Additional excavation and replacement material paid for according to Contract provisions for changes in the Work.
 - 2. Bulk Excavation: Excavations more than 10 feet in width and pits more than 30 feet in either length or width.
 - 3. Unauthorized Excavation: Excavation below subgrade elevations or beyond indicated dimensions without direction by Engineer. Unauthorized excavation, as well as remedial work directed by Engineer, without additional compensation.
- G. Fill: Soil materials used to raise existing grades.
- H. Rock: Rock material in beds, ledges, unstratified masses, and conglomerate deposits and boulders of rock material exceeding 1 cu. yd. for bulk excavation or 3/4 cu. yd. for footing, trench, and pit excavation that cannot be removed by rock excavating equipment equivalent to the following in size and performance ratings, without systematic drilling, ram hammering, ripping, or blasting, when permitted:
 - 1. Rock Excavation, Trench: Late-model, track-mounted hydraulic excavator; equivalent to Caterpillar Model N, 235D LC; measured according to SAE J-1179.
 - 2. Rock Excavation, Mass: Late-model, track-mounted loader with a hydraulically operated power ripper; equivalent to Caterpillar Model No. D-8N, Heavy Duty; measured according to SAE J-732.
 - 3. This classification does not include loose rock, concrete, or other materials that can be removed by means other than drilling and blasting, but which is chosen to remove by drilling and blasting.
- I. Structures: Buildings, footings, foundations, retaining walls, slabs, tanks, curbs, mechanical and electrical appurtenances, or other man-made stationary features constructed above or below the ground surface.
- J. Subbase Course: Layer of standardized ABC Stone installed over the subgrade and prior to flexible or ridged pavement system.
- K. Subgrade: Surface or elevation remaining after completing excavation, or top surface of a fill or backfill below subbase, drainage fill, or topsoil materials.
- L. Topsoil: Natural or cultivated surface-soil layer containing organic matter and sand, silt, and clay particles; friable, pervious, and black or a darker shade of brown, gray, or red than underlying subsoil; reasonably free of subsoil, clay lumps, gravel, and other objects more than 2 inches in diameter; and free of weeds, roots, and other deleterious materials.
- M. Unsatisfactory Soils: ASTM D2487 soil classification groups MH, CL, CH, OL, OH, and PT, or a combination of these group symbols.
 - 1. Unsatisfactory soils also include satisfactory soils not maintained within 2 percent of optimum moisture content at time of compaction.
- N. Utilities include on-site underground pipes, conduits, ducts, and cables, as well as underground services within buildings.

- O. Uncontaminated Stone: Rock material that has not been combined with a significant amount of foreign soils.

1.5 MATERIALS OWNERSHIP

- A. Materials indicated to be stockpiled are the Owner's property.
- B. Store on site.

1.6 SUBMITTALS

- A. Product Data: Manufacturer's Product Data Sheets for materials specified certifying material complies with specified requirements.
- B. Test Reports: Submit test reports indicating suitability of materials supplied from offsite.

1.7 PROJECT CONDITIONS

- A. Existing Utilities: Do not interrupt utilities serving facilities occupied by Owner or others unless permitted in writing by Owner and Engineer and then only after arranging to provide temporary utility services according to requirements indicated:
 - 1. Notify Engineer not less than two days in advance of proposed utility interruptions.
 - 2. Do not proceed with utility interruptions without Engineer's written permission.
 - 3. Contact utility-locator service for area where Project is located before excavating.

PART 2 PRODUCTS

2.1 SOIL MATERIALS

- A. General: Provide borrow soil materials when sufficient satisfactory soil materials are not available from excavations.
- B. Satisfactory Soils: ASTM D2487 soil classification groups GC, SC, CL, ML, GW, GP, GM, SW, SP, and SM, or a combination of these group symbols; free of rock or gravel larger than 3 inches in any dimension, debris, waste, frozen materials, vegetation, and other deleterious matter.
- C. Backfill and Fill: Satisfactory soil materials.
- D. Subbase: Naturally or artificially graded mixture of natural or crushed gravel, crushed stone, and natural or crushed sand; ASTM D2940/D2940M; with at least 90 percent passing a 1-1/2- inch sieve and not more than 12 percent passing a No. 200 sieve.
- E. Base: Naturally or artificially graded mixture of natural or crushed gravel, crushed stone, and natural or crushed sand; ASTM D2940/D2940M; with at least 95 percent passing a 1-1/2-inch sieve and not more than 8 percent passing a No. 200 sieve.
- F. Engineered Fill: Naturally or artificially graded mixture of natural or crushed gravel, crushed stone, and natural or crushed sand; ASTM D2940/D2940M; with at least 90 percent passing a 1-1/2-inch sieve and not more than 12 percent passing a No. 200 sieve.

- G. Bedding: Naturally or artificially graded mixture of natural or crushed gravel, crushed stone, and natural or crushed sand; ASTM D2940/D2940M; except with 100 percent passing a 1-inch sieve and not more than 8 percent passing a No. 200 sieve.

2.2 ACCESSORIES

- A. Detectable Warning Tape: Acid- and alkali-resistant polyethylene film warning tape manufactured for marking and identifying underground utilities, minimum 6 inches wide and 4 mils thick, continuously inscribed with a description of utility, with metallic core encased in a protective jacket for corrosion protection, detectable by metal detector when tape is buried up to 30 inches deep; colored as follows:
 - 1. Red: Electric.
 - 2. Yellow: Gas, oil, steam, and dangerous materials.
 - 3. Orange: Telephone and other communications.
 - 4. Blue: Water systems.
 - 5. Green: Sewer systems.
 - 6. Use warning tape type and color as directed by Utility Agencies having jurisdiction where applicable.

2.3 SOURCE QUALITY CONTROL

- A. Test off-site materials used for suitability under requirements of this section.

PART 3 EXECUTION

3.1 PREPARATION

- A. Protect structures, utilities, sidewalks, pavements, and other facilities from damage caused by settlement, lateral movement, undermining, washout, and other hazards created by earthwork operations.
- B. Protect subgrades and foundation soils against freezing temperatures or frost. Provide protective insulating materials as necessary.
- C. Provide erosion-control measures to prevent erosion or displacement of soils and discharge of soil-bearing water runoff or airborne dust to adjacent properties and walkways.
- D. Provide one public and one private utility locate prior to the start of work. De-energize lines within 10 feet of the work and pothole for gauging proper depth.
 - 1. A vacuum truck is required for potholing within 10 feet of all utility lines.
 - 2. Potholed utilities to remain open and protected until demolition/grading is complete.
 - 3. Locate utilities within 10 days of work and refresh every 30 days.
 - 4. Inspect markings daily for signs of wear.
 - 5. Make markings clearly visible for the duration of the project.

6. Stake whiskers in gravel areas to maintain visibility.
7. Submit illustration of marked utilities prior to the start of construction.

3.2 DEWATERING

- A. Prevent surface water and ground water from entering excavations, from ponding on prepared subgrades, and from flooding Project site and surrounding area.
- B. Protect subgrades from softening, undermining, washout, and damage by rain or water accumulation.
 1. Reroute surface water runoff away from excavated areas. Do not allow water to accumulate in excavations. Do not use excavated trenches as temporary drainage ditches.
 2. Install a dewatering system to keep subgrades dry and convey ground water away from excavations. Maintain until dewatering is no longer required.

3.3 EXPLOSIVES

- A. Explosives: Do not use explosives.

3.4 TOPSOIL STRIPPING

- A. Remove sod and grass before stripping topsoil.
- B. Strip topsoil to whatever depths are encountered in a manner to prevent intermingling with underlying subsoil or other waste materials.
 1. Strip surface soil of unsuitable topsoil, including trash, debris, weeds, roots, and other waste materials.
 2. Stockpile surplus topsoil and allow for re-spreading deeper topsoil.

3.5 EXCAVATION

- A. Unclassified Excavation: Excavation to subgrade elevations regardless of the character of surface and subsurface conditions encountered, including rock, soil materials, and obstructions.
 1. If excavated materials intended for fill and backfill include unsatisfactory soil materials and rock, replace with satisfactory soil materials.
- B. Classified Excavation: Excavation to subgrade elevations classified as earth and rock. Rock excavation paid for by adjusting the Contract Sum according to unit prices included in the Contract Documents.
 1. Earth excavation includes excavating pavements and obstructions visible on surface; underground structures, utilities, and other items indicated to be removed; together with soil, boulders, and other materials not classified as rock or unauthorized excavation.
 - a. Intermittent drilling; blasting, if permitted; ram hammering; or ripping of material not classified as rock excavation is earth excavation.
 2. Rock excavation includes removal and disposal of rock.

- a. Do not excavate rock until it has been classified and cross-sectioned by Owner's Geotechnical Representative.
- C. Excavate to indicated elevations and dimensions within a tolerance of plus or minus 1 inch. Extend excavations a sufficient distance from structures for placing and removing concrete formwork, for installing services and other construction, and for inspections.
 - 1. Excavations for Footings and Foundations: Do not disturb bottom of excavation. Excavate by hand to final grade just before placing concrete reinforcement. Trim bottoms to required lines and grades to leave solid base to receive other work.
 - 2. Excavation for Underground Basins, and Mechanical or Electrical Utility Structures: Excavate to elevations and dimensions indicated within a tolerance of plus or minus 1 inch. Do not disturb bottom of excavations intended for bearing surface.

3.6 SUBGRADE

- A. Notify Engineer and Testing Agency when excavations have reached required subgrade.
- B. If Engineer or Testing Agency determines that unsatisfactory soil is present, continue excavation and replace with compacted backfill or fill material as directed.
 - 1. Additional excavation and replacement material paid for according to Contract provisions for changes in the Work.
- C. Proof roll subgrade and/or subbase with a 10 wheel loaded dump truck weighing a minimum 20 tons. Identify soft pockets and areas of excess yielding. Do not proof roll wet or saturated or frozen subgrades. Limit vehical speed to three miles per hour.
- D. Reconstruct subgrades damaged by freezing temperatures, frost, rain, accumulated water, or construction activities and retest, as directed by Engineer.

3.7 STORAGE OF SOIL MATERIALS

- A. Stockpile fill and other satisfactory excavated soil materials. Stockpile soil materials without intermixing. Place, grade, and shape stockpiles to drain surface water. Cover to prevent windblown dust.
 - 1. Stockpile soil materials away from edge of excavations. Do not store within drip line of remaining trees.

3.8 BACKFILL

- A. Place and compact backfill in excavations promptly, but not before completing the following:
 - 1. Construction below finish grade including, where applicable, dampproofing, waterproofing, and perimeter insulation.
 - 2. Surveying locations of underground utilities for record documents.
 - 3. Inspecting and testing underground utilities.
 - 4. Removing concrete formwork.
 - 5. Removing trash and debris.

6. Removing temporary shoring and bracing, and sheeting.
7. Installing permanent or temporary horizontal bracing on horizontally supported walls.

3.9 FILL

- A. Preparation: Remove vegetation, topsoil, debris, unsatisfactory soil materials, obstructions, and deleterious materials from ground surface before placing fills.
- B. Plow, scarify, bench, or break up sloped surfaces steeper than 1 vertical to 4 horizontal so fill material bonds with existing material.
- C. Place and compact fill material in layers to required elevations as follows:
 1. Use satisfactory soil material except where otherwise indicated.

3.10 MOISTURE CONTROL

- A. Uniformly moisten or aerate subgrade and subsequent fill or backfill layer before compaction to within 2 percent of optimum moisture content or as accepted by Engineer.
 1. Do not place backfill or fill material on surfaces that are muddy, frozen, or contain frost or ice.
 2. Remove and replace, or scarify and air-dry, otherwise satisfactory soil material that exceeds optimum moisture content by 2 percent and is too wet to compact to specified dry unit weight.

3.11 COMPACTION OF BACKFILLS AND FILLS

- A. Place backfill and fill materials in layers not more than 8 inches in loose depth for material compacted by heavy compaction equipment, and not more than 4 inches in loose depth for material compacted by hand-operated tampers.
- B. Place backfill and fill materials evenly around structures to required elevations, and uniformly along the length of the structure.
- C. Compact soil to not less than the following percentages of maximum dry density according to ASTM D698:
 1. Under structures, building slabs and steps scarify and re-compact top 12 inches of existing subgrade and each layer of backfill or fill material at 98 percent. Compact other fill to 95 percent unless otherwise indicated.
 2. Under pavements, compact material to a depth of 8 inches below the finished surface of the subgrade to a density of at least 100% of that obtained by compacting a sample of the material in accordance with AASHTO T 99 as modified by the referenced DOT.
 3. Under walkways, scarify and re-compact top 6 inches below subgrade and compact each layer of backfill or fill material at 95 percent.
 4. Under lawn or unpaved areas, scarify and re-compact top 12 inches below subgrade and compact each layer of backfill or fill material at 90 percent.
 5. Compact utility trenches to 95 percent.

3.12 GRADING

- A. General: Uniformly grade areas to a smooth surface, free from irregular surface changes. Comply with compaction requirements and grade to cross sections, lines, and elevations indicated.
 - 1. Provide a smooth transition between adjacent grades.
 - 2. Cut out soft spots, fill low spots, and trim high spots to comply with required surface tolerances.
- B. Site Grading: Slope grades to direct water away from buildings and to prevent ponding. Finish subgrades to required elevations within the following tolerances:
 - 1. Lawn or Unpaved Areas: Plus or minus 1 inch when tested with a 10-foot straightedge.
 - 2. Walks: Plus 1/2 inch or minus 1 inch when tested with a 10-foot straightedge.
 - 3. Pavements: Plus 1/4 inch or minus 1/2 inch when tested with a 10-foot straightedge.
- C. Grading inside Building Lines: Finish subgrade to a tolerance of plus 1/4 inch or minus 1/2 inch when tested with a 10-foot straightedge.

3.13 SUBBASE AND BASE COURSES

- A. Under pavements and walks, place subbase course on prepared subgrade and as follows:
 - 1. Place base course material over subbase.
 - 2. Compact subbase and base courses at optimum moisture content to required grades, lines, cross sections, and thickness to not less than 98 percent of maximum dry density according to ASTM D698.
 - 3. Shape subbase and base to required crown elevations and cross-slope grades.
 - 4. When thickness of compacted subbase or base course is 6 inches or less, place materials in a single layer.
 - 5. When thickness of compacted subbase or base course exceeds 6 inches, place materials in equal layers, with no layer more than 6 inches thick or less than 3 inches thick when compacted.
- B. Pavement Shoulders: Place shoulders along edges of subbase and base course to prevent lateral movement. Construct shoulders, at least 12 inches wide, of satisfactory soil materials and compact simultaneously with each subbase and base layer to not less than 95 percent of maximum dry density according to ASTM D1557.

3.14 DRAINAGE COURSE

- A. Under slabs-on-grade, place drainage course on prepared subgrade and as follows:
 - 1. Compact drainage course to required cross sections and thickness to not less than 95 percent of maximum dry unit weight according to ASTM D698.

2. When compacted thickness of drainage course is 6 inches or less, place materials in a single layer.
3. When compacted thickness of drainage course exceeds 6 inches, place materials in equal layers, with no layer more than 6 inches thick or less than 3 inches thick when compacted.

3.15 RESPREADING TOPSOIL

- A. Re-spread stockpiled topsoil in planted areas. Distribute stockpiled material in a uniform thickness as follows.
 1. Lawn Areas: 4 inches minimum.
 2. Athletic Fields: 12 inches minimum.
 3. Planting Areas: 12 inches minimum.
- B. Adjust topsoil as required by Engineer following topsoil depth testing by Owner's testing representative.

3.16 FIELD QUALITY CONTROL

- A. Testing Agency: Owner will employ a qualified independent geotechnical engineering testing agency to perform field quality-control testing.
- B. Allow testing agency to inspect and test subgrades and each fill or backfill layer. Proceed with subsequent earthwork only after test results for previously completed work comply with requirements.
- C. Footing Subgrade: At footing subgrades, at least one test of each soil stratum will be performed to verify design-bearing capacities. Subsequent verification and approval of other footing subgrades based on a visual comparison of subgrade with tested subgrade when accepted by Engineer.
- D. Testing agency will test compaction of soils in place according to ASTM D1556/D1556M, ASTM D2167, ASTM D 2922, and ASTM D 2937, as applicable. Tests will be performed at the following locations and frequencies:
 1. Paved and Building Slab Areas: At subgrade and at each compacted fill and backfill layer, at least one test per 2000 sq. ft. or less of paved area or building slab, but in no case fewer than three tests.
 2. Foundation Wall Backfill: At each compacted backfill layer, at least one test for each 100 feet or less of wall length, but no fewer than two tests.
 3. Trench Backfill: At each compacted initial and final backfill layer, at least one test for each 150 feet or less of trench length, but no fewer than two tests.
- E. When testing agency reports that subgrades, fills, or backfills have not achieved degree of compaction specified, scarify and moisten or aerate, or remove and replace soil to depth required; re-compact and retest until specified compaction is obtained.

3.17 PROTECTION

- A. Protecting Graded Areas: Protect graded areas from traffic, freezing, and erosion. Keep free of trash and debris.

- B. Repair and reestablish grades to specified tolerances where completed or partially completed surfaces become eroded, rutted, settled, or where they lose compaction due to subsequent construction operations or weather conditions.
 - 1. Scarify or remove and replace soil material to depth as directed by Engineer; reshape and re-compact.
- C. Where settling occurs before Project correction period elapses, remove finished surfacing, backfill with additional soil material, compact, and reconstruct surfacing.
 - 1. Restore appearance, quality, and condition of finished surfacing to match adjacent work, and eliminate evidence of restoration to the greatest extent possible.
- D. Install temporary erosion control measures as stated in Section 01 50 00 - Temporary Facilities and Controls.

3.18 DISPOSAL OF SURPLUS AND WASTE MATERIALS

- A. Disposal: Remove surplus satisfactory soil and waste material, including unsatisfactory soil, trash, and debris, and legally dispose of it off Owner's property.

END OF SECTION

SECTION 31 23 17

TRENCHING

PART 1 GENERAL

1.1 SUMMARY

- A. Section Includes:
1. Excavating trenches for utilities and utility structures.
 2. Bedding.
 3. Backfilling and compacting to subgrade elevations.
 4. Sheeting and Shoring.
 5. Dewatering.
 6. Compacting backfill material.

1.2 RELATED DOCUMENTS

- A. Drawings and general provisions of the Contract, including General and Supplementary Conditions, Division 1 Specification Sections and the following Specification Sections apply to this Section:
1. Section 31 00 00 - Earthwork

1.3 REFERENCE STANDARDS

- A. AASHTO T 180 - Standard Method of Test for Moisture-Density Relations of Soils Using a 4.54-kg (10-lb) Rammer and a 457-mm (18-in.) Drop; 2022, with Errata .
- B. ASTM D698 - Standard Test Methods for Laboratory Compaction Characteristics of Soil Using Standard Effort (12,400 ft-lbf/ft³ (600 kN-m/m³)); 2012 (Reapproved 2021).
- C. ASTM D1556/D1556M - Standard Test Method for Density and Unit Weight of Soil in Place by Sand-Cone Method; 2015, with Editorial Revision (2016).
- D. ASTM D1557 - Standard Test Methods for Laboratory Compaction Characteristics of Soil Using Modified Effort (56,000 ft-lbf/ft³ (2,700 kN-m/m³)); 2012 (Reapproved 2021).
- E. ASTM D2167 - Standard Test Method for Density and Unit Weight of Soil in Place by the Rubber Balloon Method; 2015.
- F. ASTM D2321 - Standard Practice for Underground Installation of Thermoplastic Pipe for Sewers and Other Gravity-Flow Applications; 2020.

1.4 DEFINITIONS

- A. Utility: Buried pipe, duct, conduit, or cable.
- B. Utility Structures: Manholes, catch basins, inlets, valve vaults, hand holes, and other utility access structures as indicated on Drawings.

- C. Trench Terminology:
 - 1. Foundation: Area under bottom of trench supporting bedding.
 - 2. Bedding: Fill placed under utility pipe.
 - 3. Haunching: Fill placed from bedding to center line of pipe.
 - 4. Initial Backfill: Fill place from center line to 6 to 12 inches above top of pipe.
 - 5. Final Backfill: Fill placed from initial backfill to subgrade.

1.5 SUBMITTALS

- A. Product Data: Manufacturer's Product Data Sheets for materials specified certifying material complies with specified requirements.
- B. Excavation Protection Plan: Describe sheeting, shoring, and bracing materials and installation required to protect excavations and adjacent structures and property; include structural calculations to support plan. Prepare excavation protection plan under direct supervision of Professional Engineer experienced in design of this Work licensed in the applicable state.
- C. Dewatering Plan: Describe methods of dewatering and disposal of water.
- D. Samples: Submit to testing laboratory, in air-tight containers, 30-pound sample of each type of fill.
- E. Materials Source: Submit name of imported fill material suppliers.
- F. Manufacturer's Certificate: Certify products meet or exceed specified requirements.

1.6 COORDINATION

- A. Verify Work associated with lower elevation utilities is complete before placing higher elevation utilities. Notify the Engineer of conflicts.

PART 2 PRODUCTS

2.1 BACKFILL MATERIALS

- A. Subsoil Fill: Clean natural soil with a plasticity index of 15 or less that is free of clay, rock, or gravel lumps larger than 2 inches in any dimension; debris; waste; frozen material; and other deleterious material that cause settlement. Suitable material excavated from the site can be used as subsoil fill under optimum moisture conditions.
- B. Granular Fill: Clean sand, slightly silty sand, or slightly clayey sand having a Unified Soil Classification of SW, SP, SP-SM or SP-SC.
- C. Foundation Stone: Clean coarse aggregate conforming to a state standard for bedding.
- D. Bedding and Haunching Material:
 - 1. Flexible Pipe: ASTM D2321 Class I or II fill
- E. Initial Backfill to 6 inches Minimum Above Utility:
 - 1. Flexible Pipe: ASTM D2321 Class I or II fill.

- F. Final Backfill to Subgrade:
 - 1. Under Pavement: ASTM D2321 Class I or II fill.
 - 2. Under Landscape: Subsoil Fill.

2.2 ACCESSORIES

- A. Geotextile Fabric: 6-ounce, non-woven, non-biodegradable

PART 3 EXECUTION

3.1 PREPARATION

- A. General: Provide safe working conditions, to prevent shifting of material, to prevent damage to structures or other work, to avoid delay to the work, in accordance with applicable safety and health regulations. Properly shore, sheet, and brace excavations which are not cut back to the proper slope and where shown. Meet the general trenching requirements of the applicable safety and health regulations for the minimum shoring, sheeting and bracing for trench excavations.
 - 1. Contractor's Responsibility: Sole responsibility for the design, methods of installation, and adequacy of the shoring, sheeting and bracing.
- B. Arrange shoring, sheeting and bracing so as not to place strain on portions of completed work until the general construction has proceeded far enough to provide ample strength.
- C. If Engineer is of the opinion that the shoring, sheeting or bracing is inadequate or unsuited for the purpose, resubmission of design calculations and working drawings may be ordered, taking into consideration the observed field conditions. Install additional shoring, sheeting and bracing as determined from calculations.
- D. Call local utility line information service indicated on Drawings not less than three working days before performing Work. If the project is located on private property, coordinate utility location with a private utility locating provider.
 - 1. Request underground utilities located and marked within and surrounding construction areas.
 - 2. Identify required lines, levels, contours, and datum locations.
- E. Protect plant life, lawns, rock outcropping, and other features remaining as portion of final landscaping.
- F. Protect benchmarks, structures, fences, sidewalks, paving, and curbs from excavating equipment and vehicular traffic.
- G. Maintain and protect above and below grade utilities indicated to remain.
- H. Establish temporary traffic control and detours when trenching is performed in public right-of-way. Relocate controls and reroute traffic as required during progress of Work.
- I. Staff the trenching process to meet OSHA, state, and local requirements for trenching operations. Additionally, follow Owner safety procedures as long as there is no contradiction in local state of federal requirements.

3.2 LINES AND GRADES

- A. Excavate to lines and grades indicated on Drawings.
 - 1. Owner reserves right to make changes in lines, grades, and depths of utilities when changes are required for Project conditions.
- B. Use laser-beam instrument with qualified operator to establish lines and grades.

3.3 TRENCHING

- A. Excavate subsoil required for utilities.
- B. Remove lumped subsoil, boulders, and rock up of 1/3 cubic yard, measured by volume.
- C. Perform excavation within 48 inches of utility service in accordance with utility's requirements or as stated in Owner's more conservative requirements.
- D. Do not advance open trench more than 200 feet ahead of installed pipe.
- E. Remove water or materials that interfere with Work.
- F. Trench Width: Excavate bottom of trenches maximum 16 inches wider than outside diameter of pipe or as indicated on Drawings.
- G. Excavate trenches to depth indicated on Drawings. Provide uniform and continuous bearing and support for bedding material and pipe.
- H. Maintain vertical faces to an elevation 12 inches above top of pipe.
 - 1. When Project conditions permit, slope or bench side walls above this elevation.
 - 2. When side walls cannot be sloped, provide sheeting and shoring to protect excavation as specified in this Section.
- I. Support Utilities and Structures:
 - 1. Keep trench width at top of trench to practical minimum to protect adjacent or crossing utility lines
 - 2. Support utilities crossing trench by means acceptable to utility company.
 - 3. Do not interfere with 45-degree bearing splay of foundations.
 - 4. Provide temporary support for structures above and below ground.
- J. When subsurface materials at bottom of trench are loose or soft, excavate to firm subgrade or to depth directed by Engineer.
 - 1. Cut out soft areas of subgrade not capable of compaction in place.
 - 2. Backfill with ASTM D2321 Class I or II fill and compact to density equal to or greater than requirements for subsequent backfill material.
- K. Trim Excavation: Hand trim for bell and spigot pipe joints where required. Remove loose matter.

- L. Correct areas over excavated areas with compacted backfill as specified for authorized excavation or replace with fill concrete as directed by Engineer.
- M. Place geotextile fabric over trench foundation stone prior to placing subsequent bedding materials.

3.4 SHEETING AND SHORING

- A. Sheet, shore, and brace excavations to prevent danger to persons, structures, and adjacent properties and to prevent caving, erosion, and loss of surrounding subsoil.
- B. Support trenches more than 5 feet deep excavated through unstable, loose, or soft material. Provide sheeting, shoring, bracing, or other protection to maintain stability of excavation.
- C. Design sheeting and shoring to be removed at completion of excavation work unless approved by Engineer.
- D. Repair damage caused by failure of the sheeting, shoring, or bracing and for settlement of filled excavations or adjacent soil.
- E. Repair damage to Work from settlement, water, or earth pressure or other causes resulting from inadequate sheeting, shoring, or bracing.

3.5 SURFACE WATER CONTROL

- A. Control and remove unanticipated water seepage into excavation.
- B. Provide ditches, berms, and other devices to divert and drain surface water from excavation area as specified.
- C. Divert surface water and seepage water within excavation areas into sumps or settling basins prior to pumping water into drainage channels and storm drains.

3.6 DEWATERING

- A. Design and provide dewatering system to provide dry and stable subgrade.
- B. Operate dewatering system continuously until backfill is minimum 2 feet above normal ground water table elevation.
- C. When dewatering system cannot control water within excavation, notify Engineer and stop excavation work.
 - 1. Supplement or modify dewatering system and provide other remedial measures to control water within excavation.
 - 2. Demonstrate dewatering system operation complies with performance requirements before resuming excavation operations.
- D. Modify dewatering systems when operation causes or threatens to cause damage to construction, existing site improvements, adjacent property, or adjacent water wells.
- E. Discharge ground water and seepage water within excavation areas through filter bags or into settling basins prior to pumping water into drainage channels and storm drains.
- F. Remove dewatering and surface water control systems after dewatering operations are discontinued.

3.7 BEDDING, HAUNCHING, AND INITIAL BACKFILL

- A. Place bedding the width of trench to the depth indicated on Drawings and compact to 95 percent maximum density. Excavate for pipe bells.
- B. Install utility pipe and conduit in accordance with the respective utility section.
- C. Support pipe uniformly along length of pipe.
- D. Carefully place haunching material to center of pipe, rod and tamp material to fill voids and provide uniform support of pipe haunches. Compact to 90 percent maximum density.
- E. Carefully place initial backfill to 6 inches above top of pipe or to depth indicated on Drawings. Compact to 95 percent maximum density.

3.8 FINAL BACKFILLING TO SUBGRADE

- A. Backfill trenches to contours and elevations with unfrozen fill materials.
- B. Systematically backfill to allow maximum time for natural settlement. Do not backfill over porous, wet, frozen, or spongy subgrade surfaces.
- C. Place fill material in continuous layers and compact in accordance with schedule at end of this Section.
- D. Employ placement method that does not disturb or damage utilities in trench or foundation perimeter drainage.
- E. Maintain optimum moisture content of fill materials to attain required compaction density.
- F. Do not leave more than 50 feet of trench open at end of working day.
- G. Protect open trench to prevent danger to the public.

3.9 DISPOSAL OF EXCESS MATERIAL

- A. Dispose of excess material offsite and legally.
- B. Furnish Engineer with certificate of disposal site or agreement from private property owner.

3.10 TOLERANCES

- A. Top Surface of Backfilling: plus or minus 1 inch from required elevations.

3.11 FIELD QUALITY CONTROL

- A. Perform laboratory material tests in accordance with ASTM D698, ASTM D1557 or AASHTO T 180.
- B. Perform in place compaction tests in accordance with the following:
 - 1. Density Tests: ASTM D1556/D1556M, ASTM D2167, or ASTM D2922.
 - 2. Moisture Tests: ASTM D2216, ASTM D3017.
- C. When tests indicate Work does not meet specified requirements, remove Work, replace, compact, and retest.

- D. Frequency of Tests: Two tests per lift per 1000 feet of trench. No less than one test per lift between structures.

3.12 PROTECTION OF FINISHED WORK

- A. Reshape and re-compact fills subjected to vehicular traffic during construction.

3.13 SCHEDULE OF COMPACTION

- A. Under Pavement and Slabs:

1. Granular Fill in maximum 8-inch loose lifts.
2. Compact to minimum 95 percent maximum density except the top 12 inches.
3. Compact top 12 inches to minimum 98 percent maximum density.

- B. Under Landscape Areas:

1. Subsoil Fill in maximum 8-inch loose lifts.
2. Compact to minimum 90 percent maximum density.

- C. In Unstable or Unsuitable Trench Foundation Areas:

1. Foundation Stone in maximum 12-inch loose lifts.
2. Compact to 98 percent maximum density.

END OF SECTION

SECTION 32 05 23

CEMENT AND CONCRETE FOR EXTERIOR IMPROVEMENTS

PART 1 GENERAL

1.1 SUMMARY

- A. Section Includes:
1. Provide exterior concrete system.

1.2 RELATED DOCUMENTS

- A. Drawings and general provisions of the Contract, including General and Supplementary Conditions, Division 1 Specification Sections and the following Specification Sections, apply to this Section:
1. Section 31 00 00 - Earthwork

1.3 DESCRIPTION

- A. Exterior concrete constructed upon the prepared subgrade or substrate and in conformance with the lines, grades, thickness, and cross sections shown on the Drawings meeting the following requirements:
1. Type I concrete
 2. Do not exceed a water cement ratio of 0.35
 3. Minimum system thickness of 4 inches
 4. Minimum slope of 1/8 inch per foot, where the substrate elevation allows for clearance of stationary structures.
 5. Slump between 3 and 5 inches
 6. Minimum 28-day compressive strength of 4,000 psi

1.4 REFERENCE STANDARDS

- A. ACI PRC-211.1 - Selecting Proportions for Normal-Density and High Density-Concrete - Guide; 2022.
- B. ACI PRC-305 - Guide to Hot Weather Concreting; 2020.
- C. ACI PRC-306 - Guide to Cold Weather Concreting; 2016.
- D. ACI PRC-347 - Guide to Formwork for Concrete; 2014 (Reapproved 2021).
- E. ASTM C31/C31M - Standard Practice for Making and Curing Concrete Test Specimens in the Field; 2023.
- F. ASTM C33/C33M - Standard Specification for Concrete Aggregates; 2023.
- G. ASTM C94/C94M - Standard Specification for Ready-Mixed Concrete; 2023.

- H. ASTM C143/C143M - Standard Test Method for Slump of Hydraulic-Cement Concrete; 2020.
- I. ASTM C150/C150M - Standard Specification for Portland Cement; 2022.
- J. ASTM C171 - Standard Specification for Sheet Materials for Curing Concrete; 2020.
- K. ASTM C192/C192M - Standard Practice for Making and Curing Concrete Test Specimens in the Laboratory; 2019.
- L. ASTM C231 - Standard Test Method for Air Content of Freshly Mixed Concrete by the Pressure Method; 2009.
- M. ASTM C260/C260M - Standard Specification for Air-Entraining Admixtures for Concrete; 2010a (Reapproved 2016).
- N. ASTM C494/C494M - Standard Specification for Chemical Admixtures for Concrete; 2019, with Editorial Revision (2022).
- O. ASTM C615/C615M - Standard Specification for Granite Dimension Stone; 2018, with Editorial Revision.
- P. ASTM C618 - Standard Specification for Coal Ash and Raw or Calcined Natural Pozzolan for Use in Concrete; 2023, with Editorial Revision.
- Q. ASTM C1064/C1064M - Standard Test Method for Temperature of Freshly Mixed Hydraulic-Cement Concrete; 2017.
- R. ASTM D1751 - Standard Specification for Preformed Expansion Joint Filler for Concrete Paving and Structural Construction (Nonextruding and Resilient Bituminous Types); 2018.

1.5 SUBMITTALS

- A. Product Data: Manufacturer's Product Data Sheets for materials specified certifying material complies with specified requirements.
- B. Manufacturer's Instructions: Latest edition of the Manufacturer's current material specifications and installation instructions.
- C. Product Test Reports:
 - 1. Concrete Mix Design.

1.6 DELIVERY, STORAGE AND HANDLING

- A. Deliver ready-mixed concrete in accordance with ASTM C94/C94M.
 - 1. Agitating drum required for transportation.

1.7 PROJECT CONDITIONS

- A. When air temperatures of 40°F or above are predicted to occur within the first 24 hours after placement, utilize normal application procedures.
- B. When air temperatures of 32°F - 40°F are predicted to occur within the first 24 hours after placement, with acceptance from the Engineer, heat mixing water to a maximum of 120°F.

- C. Avoid cold weather placement, 35°F and falling, of concrete due to the possibility of the concrete freezing prior to final set. If cold weather installations are required, provide special considerations in accordance with manufacturer's guidelines.

PART 2 PRODUCTS

2.1 ADMIXTURE MANUFACTURER

- A. Manufacturers:

- 1. Sika

2.2 MATERIALS

- A. Portland Cement: ASTM C150/C150M, type I unless otherwise accepted.
- B. Fly Ash: ASTM C618, Class C or F if accepted.
- C. Aggregate: ASTM C33/C33M
- D. Air-Entraining Admixtures: ASTM C260/C260M
- E. Reinforcing Steel: ASTM C615/C615M, when required by drawings.
- F. Expansion Joint Filler: ASTM D1751
- G. Sheet Materials for Curing Concrete: ASTM C171
- H. Water: Potable water as defined by US Department of Health, containing no more than 250 ppm of free chloride ions or other substances that affect the set of Portland cement. Clean, fresh, and free from injurious quantities of acid, alkali, salt, oil, organic matter, or other impurities. Provide water with sufficient pressure and volume to meet the insulation application schedule.
- I. Admixtures: High Range Water Reducing Sika ViscoCrete 2100 meeting ASTM C494/C494M, Type F.
- J. Concrete Forms: Wood, plywood or metal with a high strength and low pliability that can withstand the loads applied.

2.3 MIX DESIGN

- A. Mix materials in accordance with recommendations of manufacturer to yield the specified physical properties while following ASTM C94/C94M.
- B. Strength of the concrete tested prior to installment. Report the average of three-cylinder tests in accordance with ASTM C39, and made and cured in accordance with ASTM C192/C192M.
- C. Follow the guidelines set forth in ACI PRC-211.1 to determine suitable air content based on the nominal maximum aggregate size and the environmental exposure.
- D. Maintain a consistency suitable to provide a plastic mix capable of being screeded to a desirable finish.

PART 3 EXECUTION

3.1 EXAMINATION

- A. Verify surfaces to receive concrete have been properly prepared for installation free of grease and oil.

3.2 PREPARATION

- A. Cover drains, clean outs, etc. before installing Portland cement concrete.
- B. Remove substances that interfere with bonding of the concrete system.
- C. Set screeds to ensure concrete is applied to the required depth and height.
- D. Protect elements surrounding the work of this Section from damage or disfiguration.

3.3 APPLICATION

- A. Provide equipment and application procedures conforming to the material manufacturer's application instructions and referenced ASTM and ACI published guidelines.
- B. Follow AACI PRC-347 requirements for the installation of formwork.
 - 1. Wet forms in hot weather applications just prior to the pour.
 - 2. Clean and coat metal forms prior to reinforcement installation with light form oil.
- C. Remove debris or hardened concrete on the inside the perimeter of the pour.
- D. Distribute concrete in a fashion that does not allow segregation inside the mix.
- E. Work concrete that has not attained its initial set or has not reached its desirable water to cement ratio for longer than one and half hours.
- F. Discharge concrete no more than 3 feet horizontally above the placement position.
- G. Place in lifts not to exceed 12 inches in depth.
- H. Consolidate concrete by spading rodding and vibrating. Avoid applying the vibration to the form work.
- I. Install warm weather concrete in accordance with ACI PRC-305.
- J. Install cold weather concrete in accordance with ACI PRC-306.
- K. Calcium Chloride is not permitted as a set accelerating agent.
- L. Remove drain sump forms as soon as the concrete supports foot traffic. Mix and install drain sump material. Hand form drain sump transition from roof drain to surrounding concrete height.
- M. Do not use water alone to improve the workability of fresh concrete. Avoid using water to assist in finishing operations or working bleed water back into the top surface of the concrete as these practices increase the water-to-cement ratio of the top layer of concrete, which leads to future durability problems.
- N. Slab Finishes:

1. Broom finish an exterior slab, ramp and stair treads with a damp bristle brush
- O. Perform saw cutting as soon as the concrete has cured enough to handle the weight of the saw and cleanly cut a 1/8 inch wide joint 1/4 of the way in to the slab.
- P. Apply curing membrane over concrete deck surface as early as practical for protection against rapid evaporation or dry out. The preferred application method is spraying.
- Q. Remove forms only after the concrete has achieved sufficient strength to carry its own weight and loads. It's recommended to leave forms in place as long as possible. Form removal time frame is the responsibility of the Contractor.
- R. Prevent traffic for 28 days or until the concrete has reached the intended design strength according to the test samples. An early release can be considered based on the samples and the Engineers acceptance.

3.4 FIELD QUALITY CONTROL

- A. A third-party field-testing agency will be hired to perform the tests below:
 1. Test Specimens/Cylinders: One set of cylinders per each placement operation per 100 cubic yards in accordance with ASTM C31/C31M.
 2. Temperature: Performed on the first load and when test specimens are made in accordance with ASTM C1064/C1064M.
 3. Air Content -Pressure Air Meter: Performed on the first load, and a random load per 30 cubic yards in accordance with ASTM C231.
 4. Slump: Performed on the first load, and a random load per 30 cubic yards in accordance with ASTM C143/C143M.

3.5 CLEAN-UP

- A. Clean the site free of Portland cement stains, spills, aggregate, trash and other debris.

END OF SECTION

ORANGE COUNTY SCHOOLS

NEW HOPE ELEMENTARY SCHOOL BUILDING

ENCLOSURE MAINTENANCE & REPAIR

1900 HEW HOPE CHURCH ROAD
CHAPEL HILL, NC 27514

REI PROJECT NO. 023RAL-047

DATE: APRIL 10, 2024



Engineering solutions for tomorrow®

9121 Anson Way | Suite 100
Raleigh, NC 27615

NORTH CAROLINA
ENGINEERING FIRM
LICENSE # C-1520

www.reiengineers.com

SEALS:

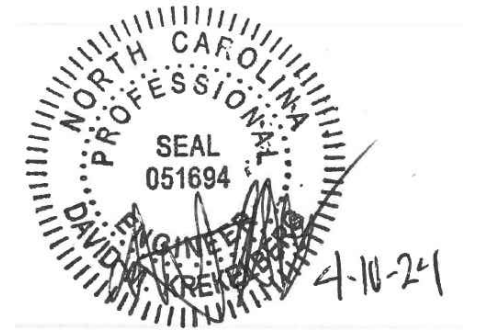

PROJECT NAME:
ORANGE COUNTY SCHOOLS

NEW HOPE ELEMENTARY
SCHOOL BUILDING
ENCLOSURE
MAINTENANCE & REPAIR

1900 HEW HOPE CHURCH ROAD
CHAPEL HILL, NC 27514

PROJ. NO:
023RAL-047

ISSUE:

NO.	DATE	DESCRIPTION
DD	11-20-23	DESIGN DEVELOPMENT
CD	12-12-23	CONTRACT DOCUMENTS (90%)
CD	04-10-24	ISSUED FOR BID

THIS LINE IS 1 INCH ON
THE ORIGINAL DRAWING

IF IT IS NOT 1 INCH ON THIS PAGE,
SCALE DRAWING ACCORDINGLY.

SHEET TITLE

COVER

DRAWING

G-001

- GENERAL NOTES:**
- THESE DOCUMENTS ARE THE PROPERTY OF REI ENGINEERS, INC. (REI) AND REI RETAINS ALL RIGHTS THEREIN, INCLUDING COPYRIGHTS. IT MAY ONLY BE USED IN A MANNER CONSISTENT WITH REI'S RIGHTS WHILE REI IS PROVIDING SERVICE FOR THE SPECIFIC PROJECT IDENTIFIED OR REFERRED TO HEREIN OR EXTENSIONS THERETO. IT MAY NOT BE USED FOR ANY OTHER PURPOSE, EXCEPT WITH THE EXPRESS WRITTEN AGREEMENT OF, AND COMPENSATION TO, REI ENGINEERS, INC.
 - DIMENSIONS, DETAIL COMPONENTS AND EQUIPMENT PENETRATION LOCATIONS ARE FOR INFORMATION ONLY. CONTRACTOR IS RESPONSIBLE TO FIELD VERIFY ALL INFORMATION PROVIDED.
 - ONLY ONE DETAIL INDICATOR MAY BE SHOWN FOR EACH TYPE OF ROOF PENETRATION. ALL OTHER SIMILAR PENETRATIONS ARE TO BE FLASHED AS REQUIRED BY THE TYPICAL DETAIL INDICATOR, UNLESS OTHERWISE NOTED.
 - NOTES ARE INTENDED TO PROVIDE TYPICAL LOCATIONS OF WORK. IT IS THE CONTRACTORS RESPONSIBILITY TO QUANTIFY ALL LOCATIONS.

- DETAIL NOTES**
- LIGHT LINES REPRESENT EXISTING CONSTRUCTION TO REMAIN AND DARK LINES REPRESENT NEW COMPONENTS TO BE PROVIDED.

- ELEVATION NOTES**
- ELEVATIONS ARE PROVIDED FOR REFERENCE. ACTUAL CONDITIONS MAY VARY ON EACH BUILDING ELEVATION. CONTRACTOR SHALL FIELD VERIFY CONDITIONS PRESENT ON EACH ELEVATION.

- ABBREVIATION LIST:**
- AB ABANDONED
 - ALUM. ALUMINUM
 - BLDG. BUILDING
 - CJ CONTROL JOINT
 - DS DOWNSPOUT
 - EJ EXPANSION JOINT
 - EPDM ETHYLENE PROPYLENE DIENE MONOMER
 - EX. EXISTING
 - GALV. GALVANIZE
 - GA. GAUGE
 - HT. HEIGHT
 - MAX. MAXIMUM
 - MIN. MINIMUM
 - N.I.C. NOT IN CONTRACT
 - NOM. NOMINAL
 - N.T.S. NOT TO SCALE
 - O.C. ON CENTER
 - OF OVERFLOW
 - PS PRESSURE SENSITIVE
 - PVC POLYVINYL CHLORIDE
 - SF SQUARE FEET
 - S.S. STAINLESS STEEL
 - SIM. SIMILAR
 - TERM. TERMINATE/TERMINATION
 - TYP. TYPICAL
 - VIF VERIFY IN FIELD

- DRAWING INDEX:**
- G-001 COVER
 - XW101 SITE PLAN
 - XW201 TYPICAL ELEVATIONS
 - XW501 DETAILS
 - XW502 DETAILS

- BUILDING CODE REFERENCE:**
- 2018 NCBC: BUILDING
 - 2018 NCBC: ENERGY CONSERVATION
 - 2018 NCBC: EXISTING BUILDING
 - 2018 NCBC: FIRE PREVENTION
 - 2018 NCBC: FUEL GAS
 - 2018 NCBC: MECHANICAL
 - 2018 NCBC: PLUMBING

- KEY**
- LIMITS OF WORK
 - - - INCLUDED IN CONTRACT
 - ▨ STAGING AND MATERIAL STORAGE

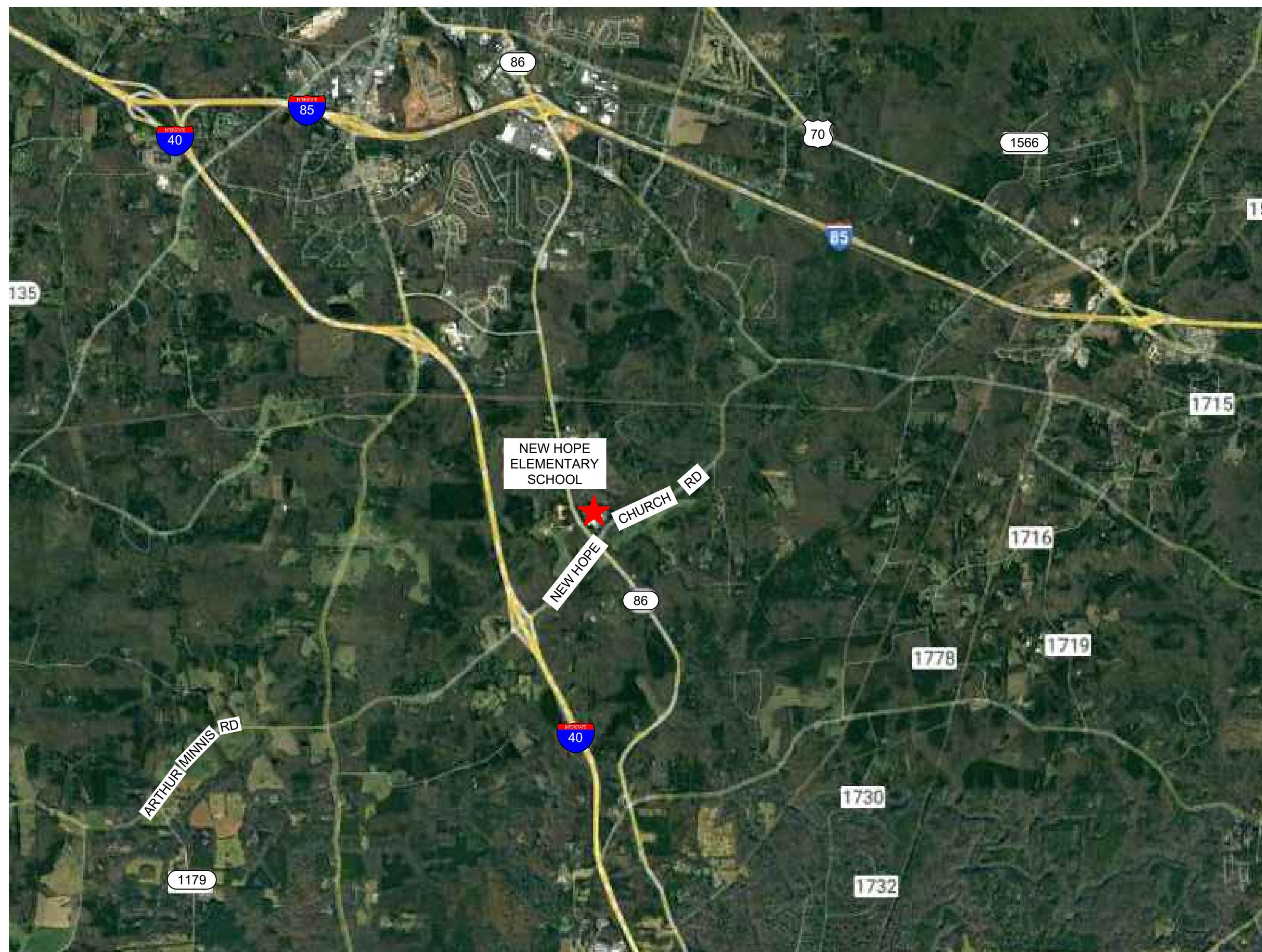

A VICINITY MAP
SCALE: N.T.S.

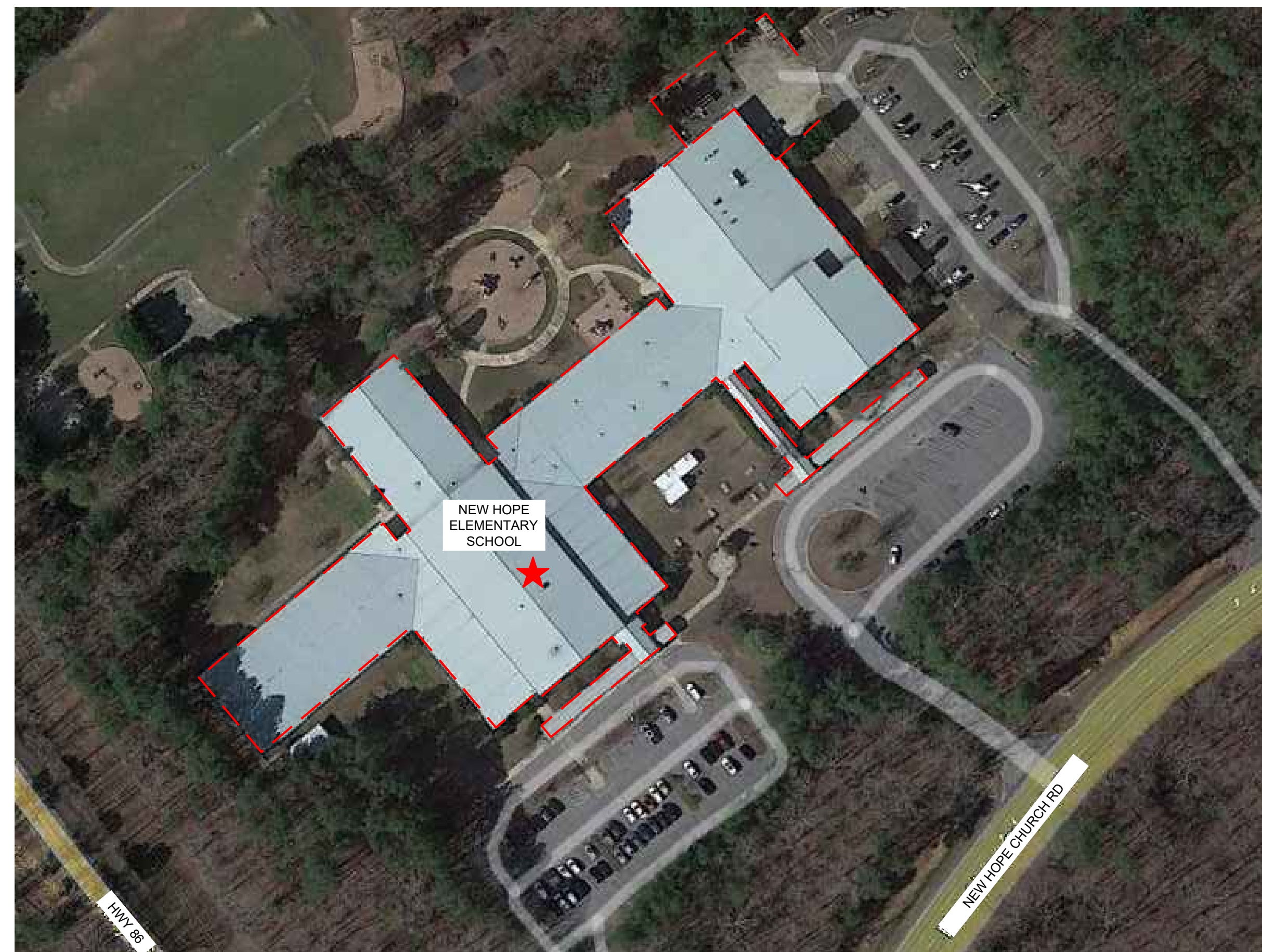

B SITE PLAN
SCALE: N.T.S.





ENGINEERS

Engineering solutions for tomorrow®

9121 Anson Way | Suite 100
Raleigh, NC 27615

NORTH CAROLINA
ENGINEERING FIRM
LICENSE # C-1520

www.reiengineers.com

SEALS:



PROJECT NAME:
ORANGE COUNTY SCHOOLS

**NEW HOPE ELEMENTARY
SCHOOL BUILDING
ENCLOSURE
MAINTENANCE & REPAIR**

1900 HEW HOPE CHURCH ROAD
CHAPEL HILL, NC 27514

PROJ. NO:
023RAL-047

ISSUE:

NO.	DATE	DESCRIPTION
DD	11-20-23	DESIGN DEVELOPMENT
CD	12-12-23	CONTRACT DOCUMENTS (90%)
CD	04-10-24	ISSUED FOR BID

THIS LINE IS 1 INCH ON
THE ORIGINAL DRAWING

IF IT IS NOT 1 INCH ON THIS PAGE,
SCALE DRAWING ACCORDINGLY.

SHEET TITLE

SITE PLAN

DRAWING

XW101

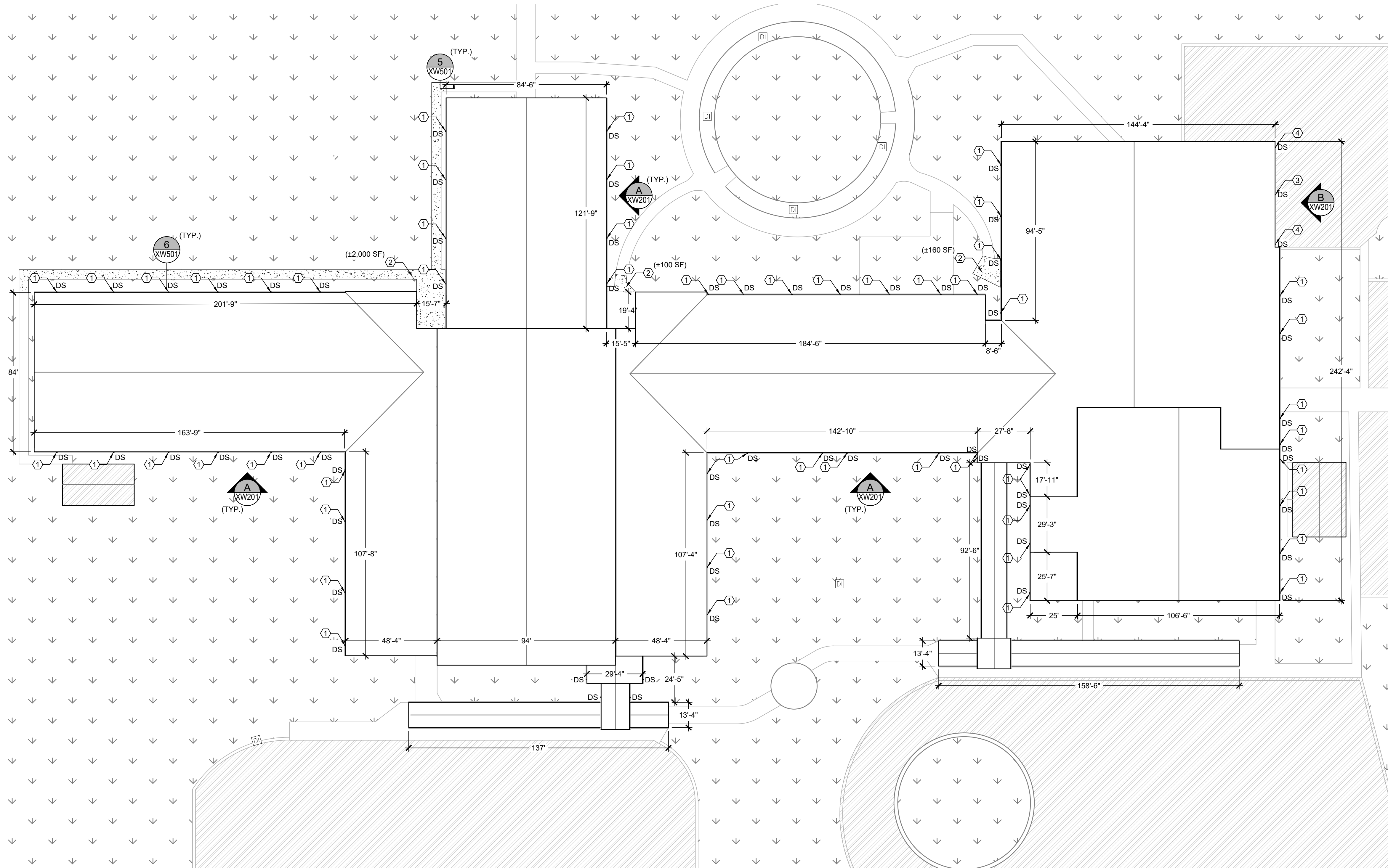

GENERAL NOTES:

- THESE DOCUMENTS ARE THE PROPERTY OF REI ENGINEERS, INC. (REI) AND REI RETAINS ALL RIGHTS THEREIN, INCLUDING COPYRIGHTS. IT MAY ONLY BE USED IN A MANNER CONSISTENT WITH REI'S RIGHTS WHILE REI IS PROVIDING SERVICE FOR THE SPECIFIC PROJECT IDENTIFIED OR REFERRED TO HEREIN OR EXTENSIONS THERETO. IT MAY NOT BE USED FOR ANY OTHER PURPOSE EXCEPT WITH THE EXPRESS WRITTEN AGREEMENT OF, AND COMPENSATION TO, REI ENGINEERS, INC.
- DIMENSIONS, DETAIL COMPONENTS AND EQUIPMENT PENETRATION LOCATIONS ARE FOR INFORMATION ONLY. CONTRACTOR IS RESPONSIBLE TO FIELD VERIFY ALL INFORMATION PROVIDED.
- ONLY ONE DETAIL INDICATOR MAY BE SHOWN FOR EACH TYPE OF ROOF PENETRATION. ALL OTHER SIMILAR PENETRATIONS ARE TO BE FLASHED AS REQUIRED BY THE TYPICAL DETAIL INDICATOR, UNLESS OTHERWISE NOTED.
- NOTES ARE INTENDED TO PROVIDE TYPICAL LOCATIONS OF WORK. IT IS THE CONTRACTOR'S RESPONSIBILITY TO QUANTIFY ALL LOCATIONS.

SHEET NOTES:

- PROVIDE DOWNSPOUT CONNECTED TO EXISTING GUTTER. PROVIDE BOOT AT GRADE CONNECTED TO EXISTING STORM DRAIN LINE. CAP EXISTING DRAIN LINE AND PATCH EXTERIOR WALL. REFER TO DETAILS 1/XW502 & 2/XW502.
- REPLACE CONCRETE SIDEWALKS AS REQUIRED TO PERFORM DOWNSPOUT/STORM WATER REPAIRS. REFER TO DETAIL 4/XW501.
- CLEAR DOWNSPOUT AT CENTER OF LOADING DOCK TO BE FREE FLOWING.
- ROUTE DOWNSPOUT TO GRADE ADJACENT TO LOADING DOCK AREA. DO NOT IMPEDE WALKING PATH OR ACCESS TO LOADING DOCK. SIMILAR TO DETAILS 1/XW502 & 2/XW502.

KEY

	ROOF EDGE
	GUTTER EDGE
	SHEET NOTE SYMBOL
	DETAIL INDICATOR

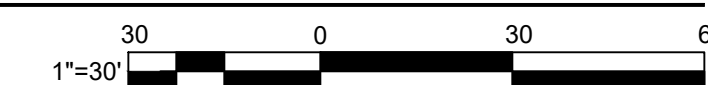

A PLAN
SCALE: 1"=30'



ENGINEERS

Engineering solutions for tomorrow®

9121 Anson Way | Suite 100
Raleigh, NC 27615

NORTH CAROLINA
ENGINEERING FIRM
LICENSE # C-1520

www.reiengineers.com

SEALS:

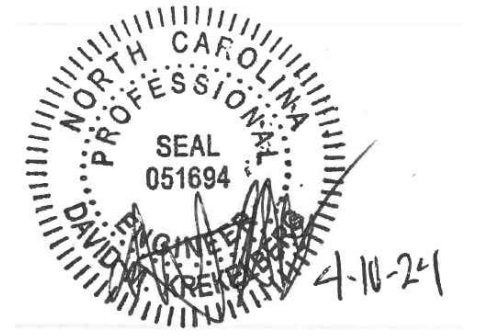

PROJECT NAME:
ORANGE COUNTY SCHOOLS

NEW HOPE ELEMENTARY
SCHOOL BUILDING
ENCLOSURE
MAINTENANCE & REPAIR

1900 HEW HOPE CHURCH ROAD
CHAPEL HILL, NC 27514

PROJ. NO:
023RAL-047

ISSUE:		
NO.	DATE	DESCRIPTION
DD	11-20-23	DESIGN DEVELOPMENT
CD	12-12-23	CONTRACT DOCUMENTS (90%)
CD	04-10-24	ISSUED FOR BID

THIS LINE IS 1 INCH ON
THE ORIGINAL DRAWING
IF IT IS NOT 1 INCH ON THIS PAGE,
SCALE DRAWING ACCORDINGLY.

SHEET TITLE

TYPICAL
ELEVATIONS

DRAWING

XW201

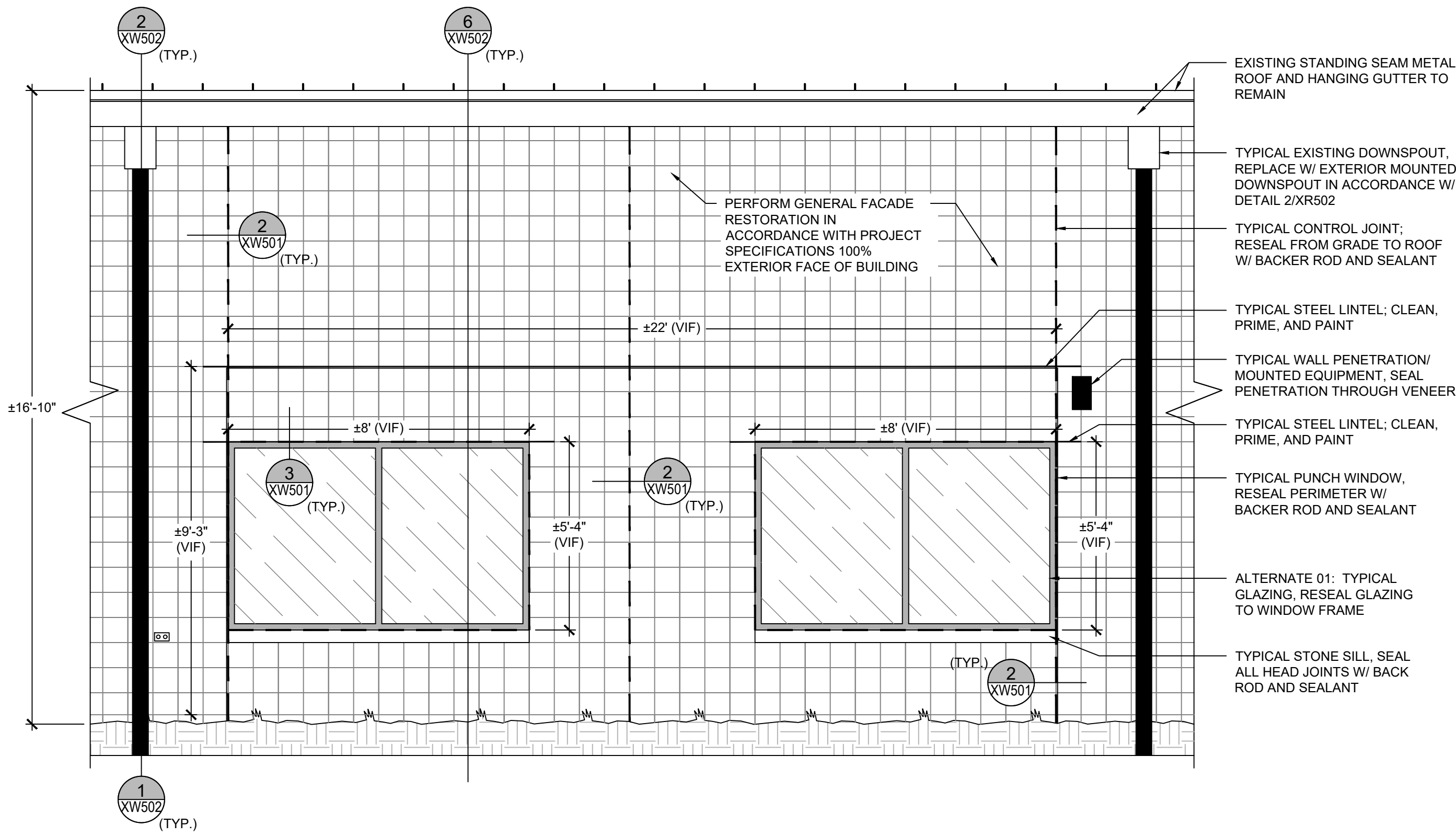

A TYPICAL CLASSROOM WINDOW ELEVATION

SCALE: 3/8" = 1'-0"

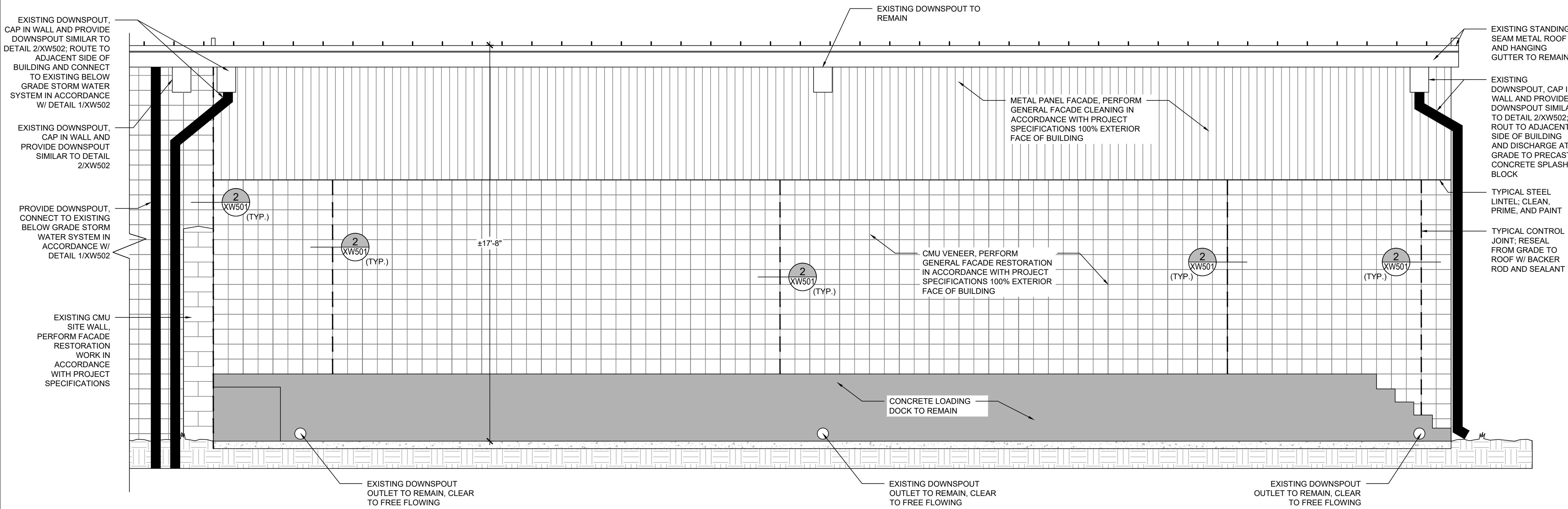

B LOADING DOCK ELEVATION

SCALE: 3/8" = 1'-0"



- GENERAL NOTES:**
- THESE DOCUMENTS ARE THE PROPERTY OF REI ENGINEERS, INC. (REI) AND REI RETAINS ALL RIGHTS THEREIN, INCLUDING COPYRIGHTS. IT MAY ONLY BE USED IN A MANNER CONSISTENT WITH REI'S RIGHTS WHILE REI IS PROVIDING SERVICE FOR THE SPECIFIC PROJECT IDENTIFIED OR REFERRED TO HEREIN OR EXTENSIONS THERETO. IT MAY NOT BE USED FOR ANY OTHER PURPOSE EXCEPT WITH THE EXPRESS WRITTEN AGREEMENT OF, AND COMPENSATION TO, REI ENGINEERS, INC.
 - DIMENSIONS, DETAIL COMPONENTS AND EQUIPMENT PENETRATION LOCATIONS ARE FOR INFORMATION ONLY. CONTRACTOR IS RESPONSIBLE TO FIELD VERIFY ALL INFORMATION PROVIDED.
 - ONLY ONE DETAIL INDICATOR MAY BE SHOWN FOR EACH TYPE OF ROOF PENETRATION. ALL OTHER SIMILAR PENETRATIONS ARE TO BE FLASHED AS REQUIRED BY THE TYPICAL DETAIL INDICATOR, UNLESS OTHERWISE NOTED.
 - NOTES ARE INTENDED TO PROVIDE TYPICAL LOCATIONS OF WORK. IT IS THE CONTRACTOR'S RESPONSIBILITY TO QUANTIFY ALL LOCATIONS.
- SHEET NOTES:**
- ELEVATIONS ARE PROVIDED FOR REFERENCE. ACTUAL CONDITIONS MAY VARY ON EACH BUILDING ELEVATION. CONTRACTOR SHALL FIELD VERIFY CONDITIONS PRESENT ON EACH ELEVATION.

KEY

—	ROOF EDGE
- - -	CONTROL JOINT
—	LINTEL
—	BUILDING PROFILE
□	CMU VENEER
▨	METAL WALL PANEL
⊘	DETAIL INDICATOR



Engineering solutions for tomorrow®

9121 Anson Way | Suite 100
Raleigh, NC 27615

NORTH CAROLINA
ENGINEERING FIRM
LICENSE # C-1520

www.reiengineers.com

SEALS:

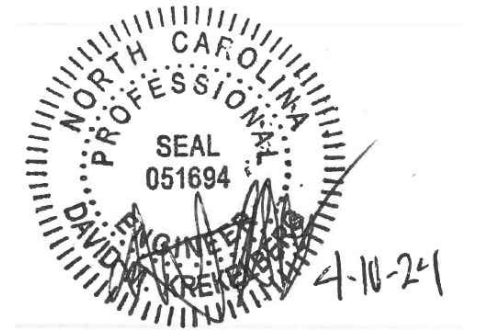

PROJECT NAME:
ORANGE COUNTY SCHOOLS

**NEW HOPE ELEMENTARY
SCHOOL BUILDING
ENCLOSURE
MAINTENANCE & REPAIR**

1900 HEW HOPE CHURCH ROAD
CHAPEL HILL, NC 27514

PROJ. NO:
023RAL-047

NO.	DATE	DESCRIPTION
DD	11-20-23	DESIGN DEVELOPMENT
CD	12-12-23	CONTRACT DOCUMENTS (90%)
CD	04-10-24	ISSUED FOR BID

THIS LINE IS 1 INCH ON
THE ORIGINAL DRAWING

IF IT IS NOT 1 INCH ON THIS PAGE,
SCALE DRAWING ACCORDINGLY.

SHEET TITLE

DETAILS

DRAWING

XW501

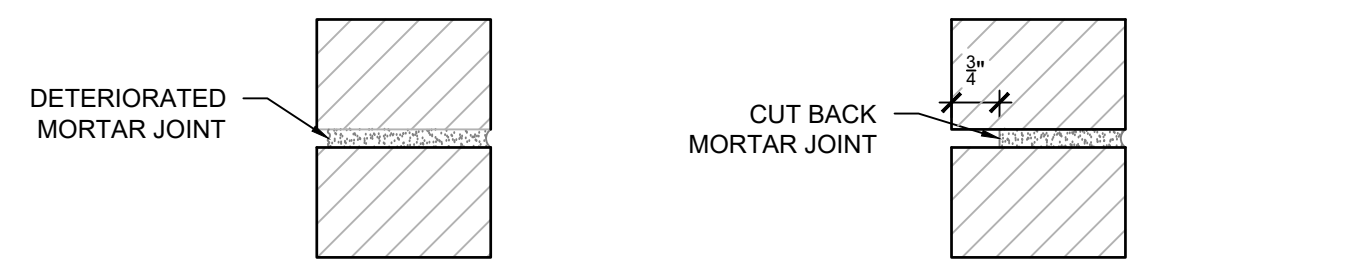

STEP 1: DETERIORATED MORTAR JOINT.
STEP 2: CUT MORTAR JOINT BACK TO UNIFORM MINIMUM DEPTH OF 3/4". DO NOT DAMAGE EDGES OF MASONRY.

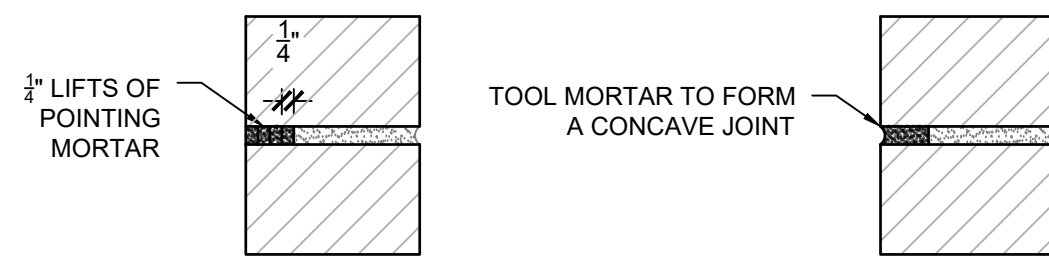

STEP 3: PACK POINTING MORTAR INTO THE JOINT IN 1/4" LIFTS.
STEP 4: TOOL MORTAR JOINT TO A CONCAVE PROFILE.

- NOTES:
- DETERMINE LOCATIONS BASED ON VISUAL INSPECTION AND PROVIDE REPOINTING IN ACCORDANCE WITH UNIT PRICES AND QUANTITY ALLOWANCES.
 - IN GENERAL REPOINT MORTAR JOINTS EXHIBITING THESE DEFICIENCIES:
 - CRACKS WIDER THAN 1/16-INCH.
 - FACE OF JOINT RECESSED MORE THAN 1/4-INCH.
 - SOFT JOINT, MORTAR EASILY REMOVED WITH POINTING TOOL.

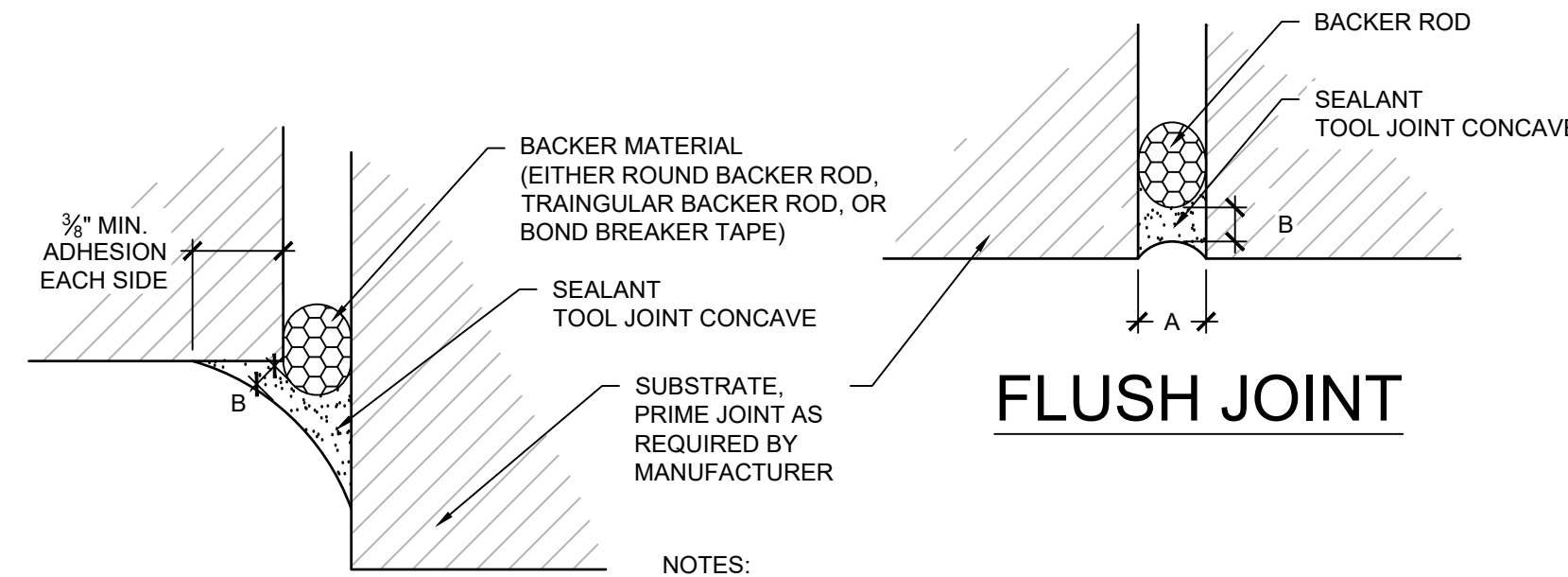

FLUSH JOINT

OFFSET JOINT

2 FACADE SEALANT JOINT REPLACEMENT
SCALE: 3" = 1'-0"

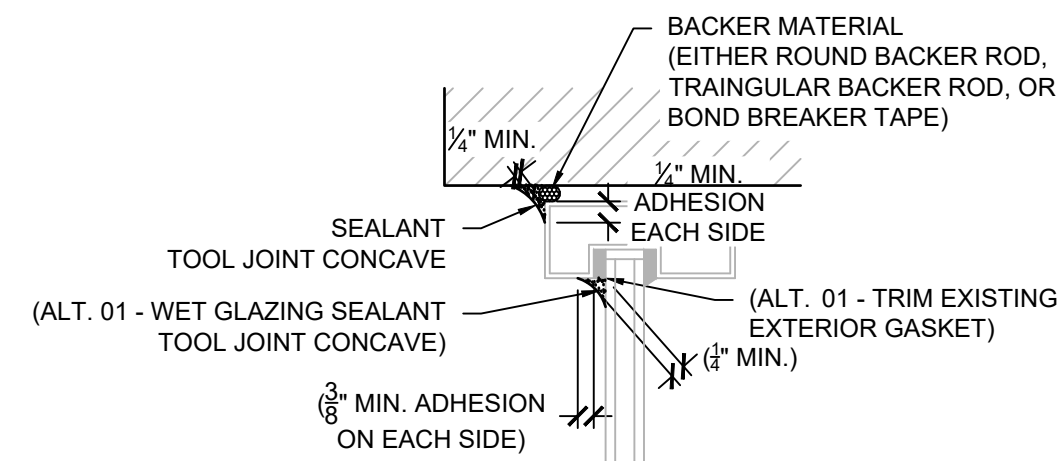

BACKER MATERIAL (EITHER ROUND BACKER ROD, TRIANGULAR BACKER ROD, OR BOND BREAKER TAPE)
SEALANT TOOL JOINT CONCAVE
SUBSTRATE, PRIME JOINT AS REQUIRED BY MANUFACTURER
NOTES:
1. DIMENSION A SHALL BE 1/4" MINIMUM
2. DIMENSION B SHALL BE 1/4" MIN. AND 1/2" MAX.
3. RATIO OF A:B SHALL BE 2:1 MINIMUM.
4. BACKER ROD DIAMETER SHALL BE 25% LARGER THAN JOINT WIDTH.

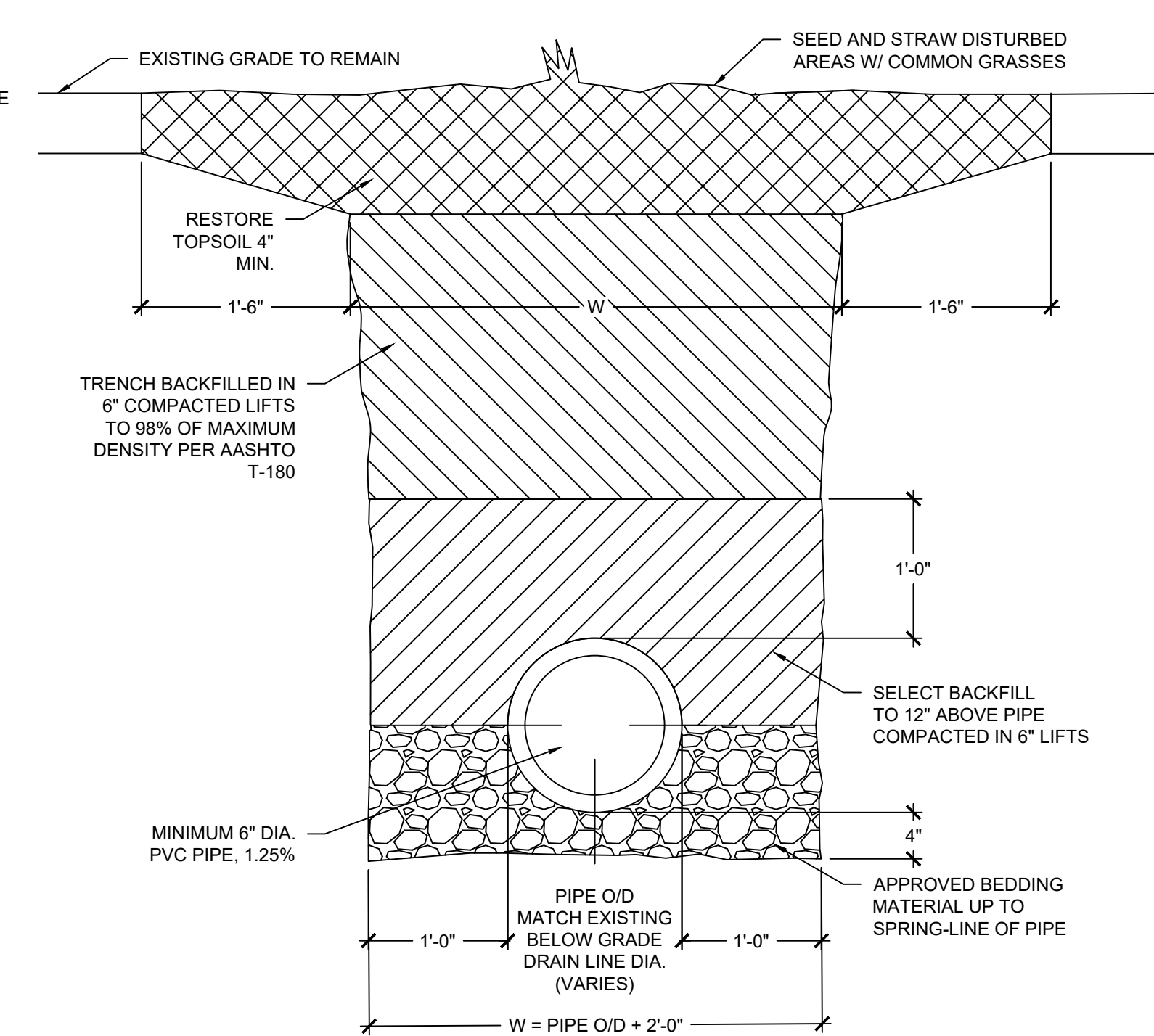

- NOTES:
- UNLESS OTHERWISE SPECIFIED SELECTED MATERIAL SHALL BE FREE OF STONES LARGER THAN 3/8" DIA. REPLACE ALL EXISTING LANE MARKINGS AND REFLECTIVE MARKERS DAMAGED BY CONSTRUCTION ACTIVITIES.

1 MASONRY REPOINTING
NOT TO SCALE

3 WINDOW SEALANT REPLACEMENT
NOT TO SCALE

4 LANDSCAPE: DRAIN PIPE & TRENCH REPAIR
SCALE: 1" = 1'-0"

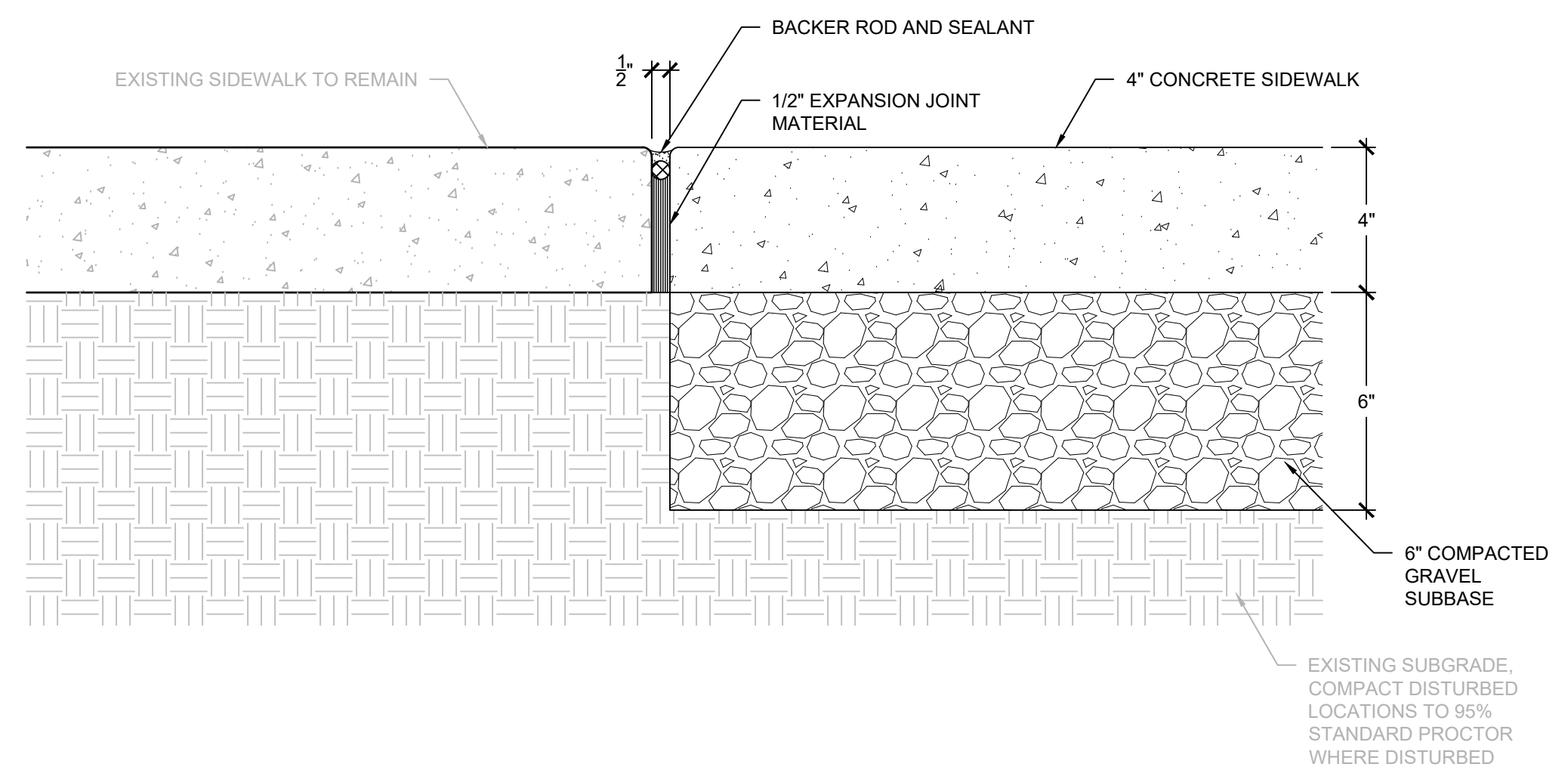

5 TYPICAL CONCRETE SIDEWALK CROSS-SECTION
SCALE: 3" = 1'-0"

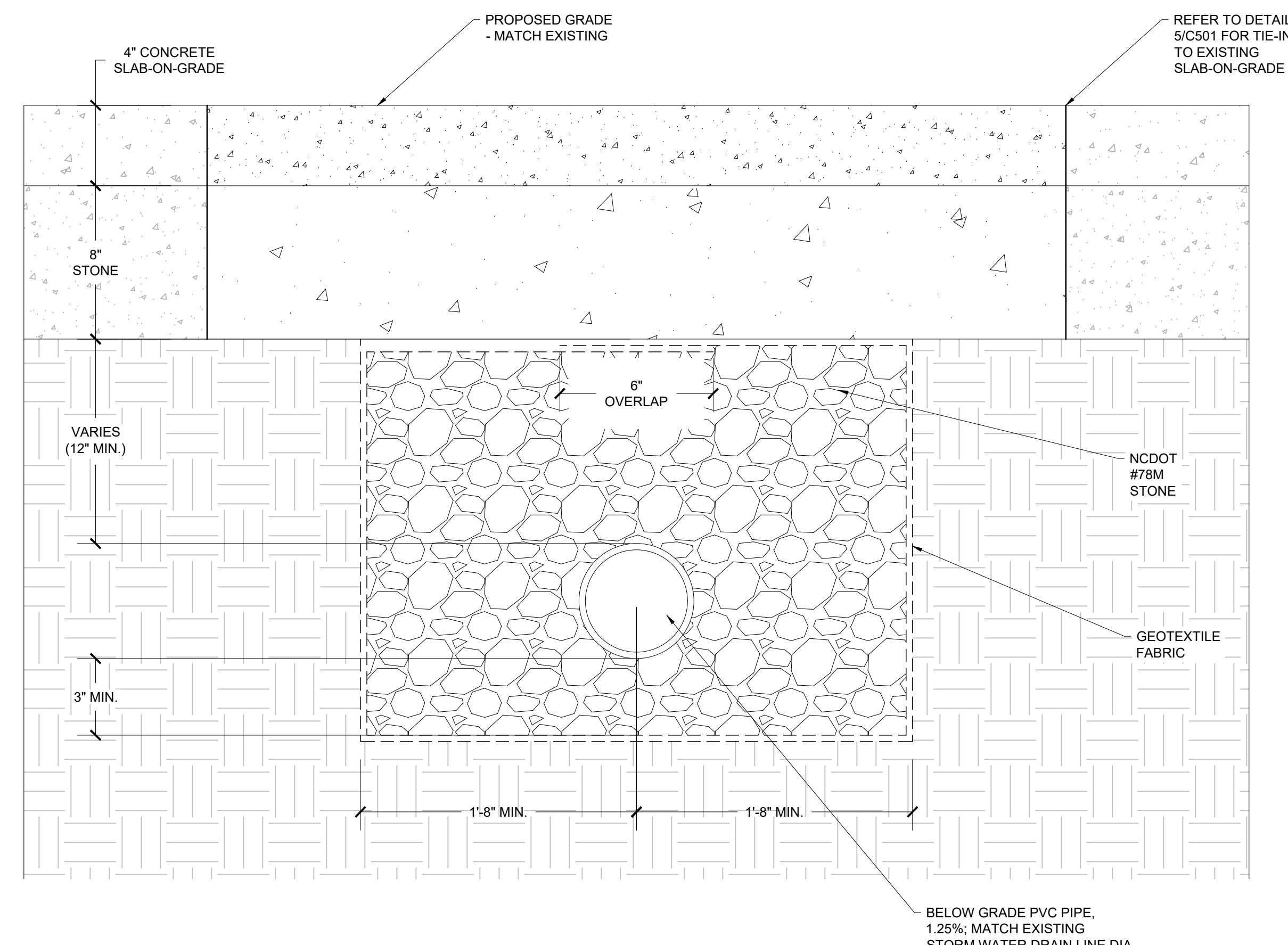

6 PAVING: DRAIN PIPE & TRENCH REPAIR
SCALE: N.T.S.

- GENERAL NOTES:
- THESE DOCUMENTS ARE THE PROPERTY OF REI ENGINEERS, INC. (REI) AND REI RETAINS ALL RIGHTS THEREIN, INCLUDING COPYRIGHTS. IT MAY ONLY BE USED IN A MANNER CONSISTENT WITH REI'S RIGHTS WHILE REI IS PROVIDING SERVICE FOR THE SPECIFIC PROJECT IDENTIFIED OR REFERRED TO HEREIN OR EXTENSIONS THERETO. IT MAY NOT BE USED FOR ANY OTHER PURPOSE EXCEPT WITH THE EXPRESS WRITTEN AGREEMENT OF, AND COMPENSATION TO, REI ENGINEERS, INC.
 - DIMENSIONS, DETAIL COMPONENTS AND EQUIPMENT PENETRATION LOCATIONS ARE FOR INFORMATION ONLY. CONTRACTOR IS RESPONSIBLE TO FIELD VERIFY ALL INFORMATION PROVIDED.
- SHEET NOTES:
- FOR DETAILS, LIGHT LINES REPRESENT EXISTING CONSTRUCTION TO REMAIN AND DARK LINES REPRESENT NEW COMPONENTS TO BE PROVIDED.

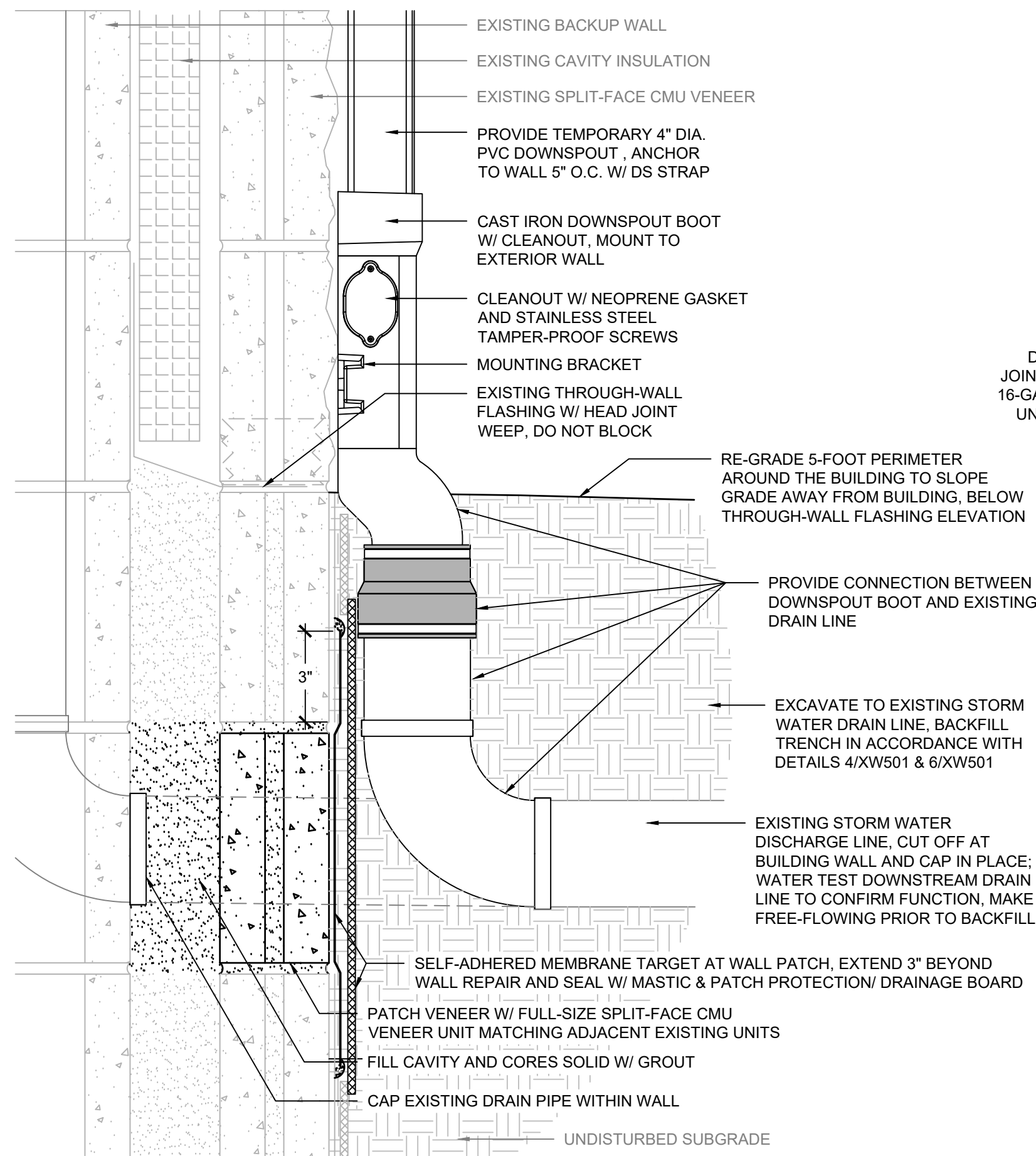

1 NEW DOWNSPOUT & BOOT @ GRADE
SCALE: 3" = 1'-0"

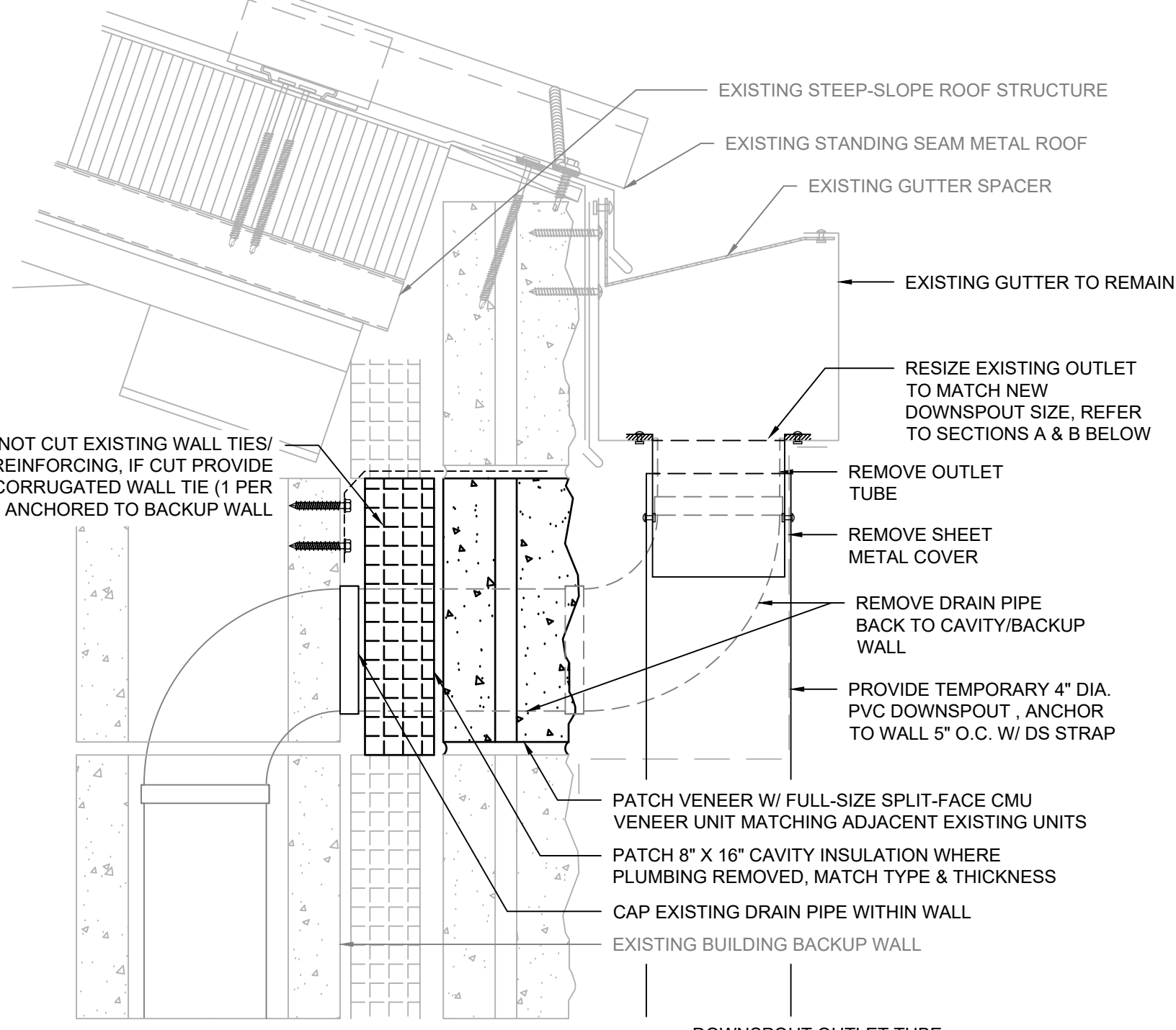

2 NEW DOWNSPOUT @ EXISTING GUTTER
SCALE: 3" = 1'-0"

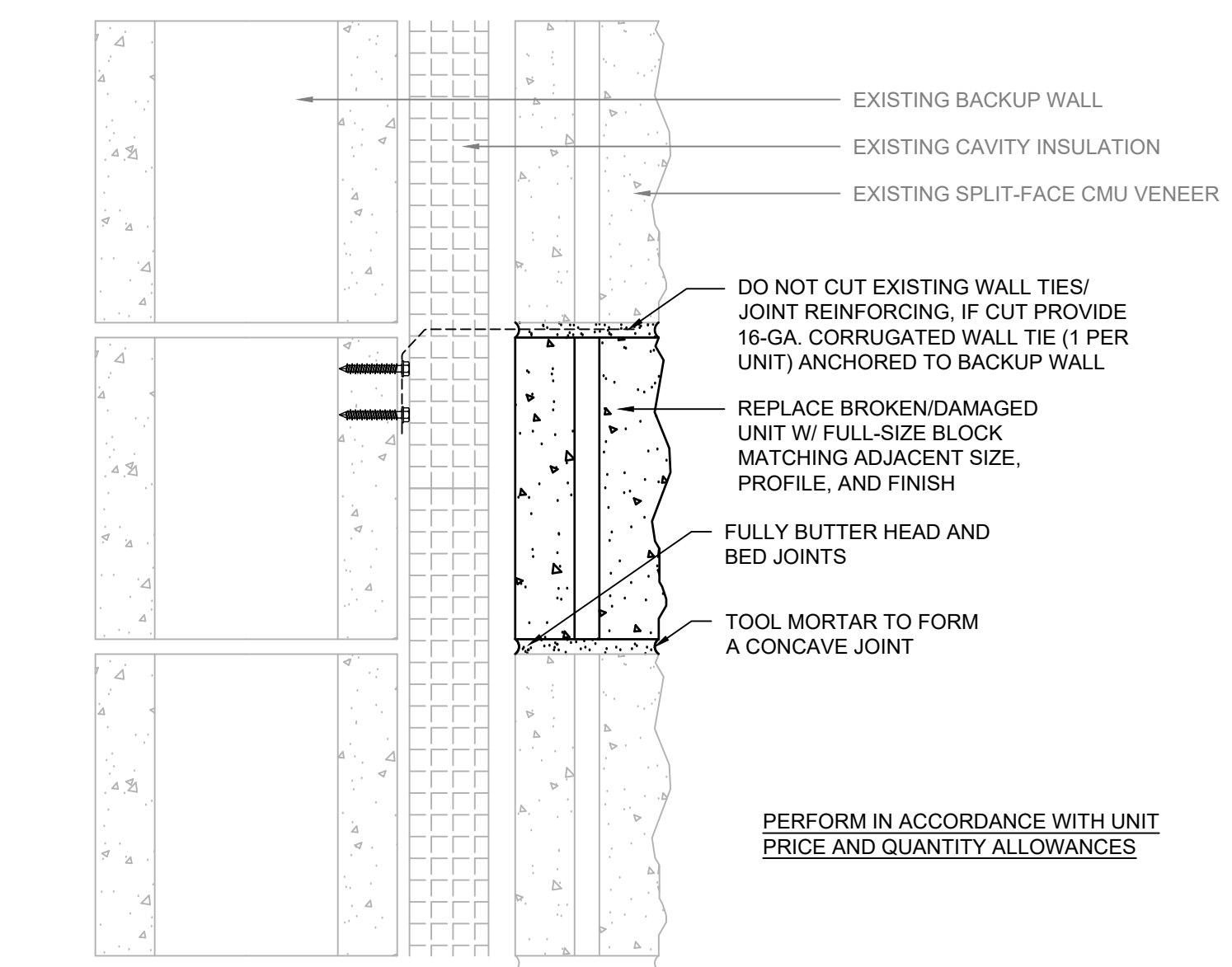

3 REPLACE CMU VENEER UNIT
SCALE: 3" = 1'-0"

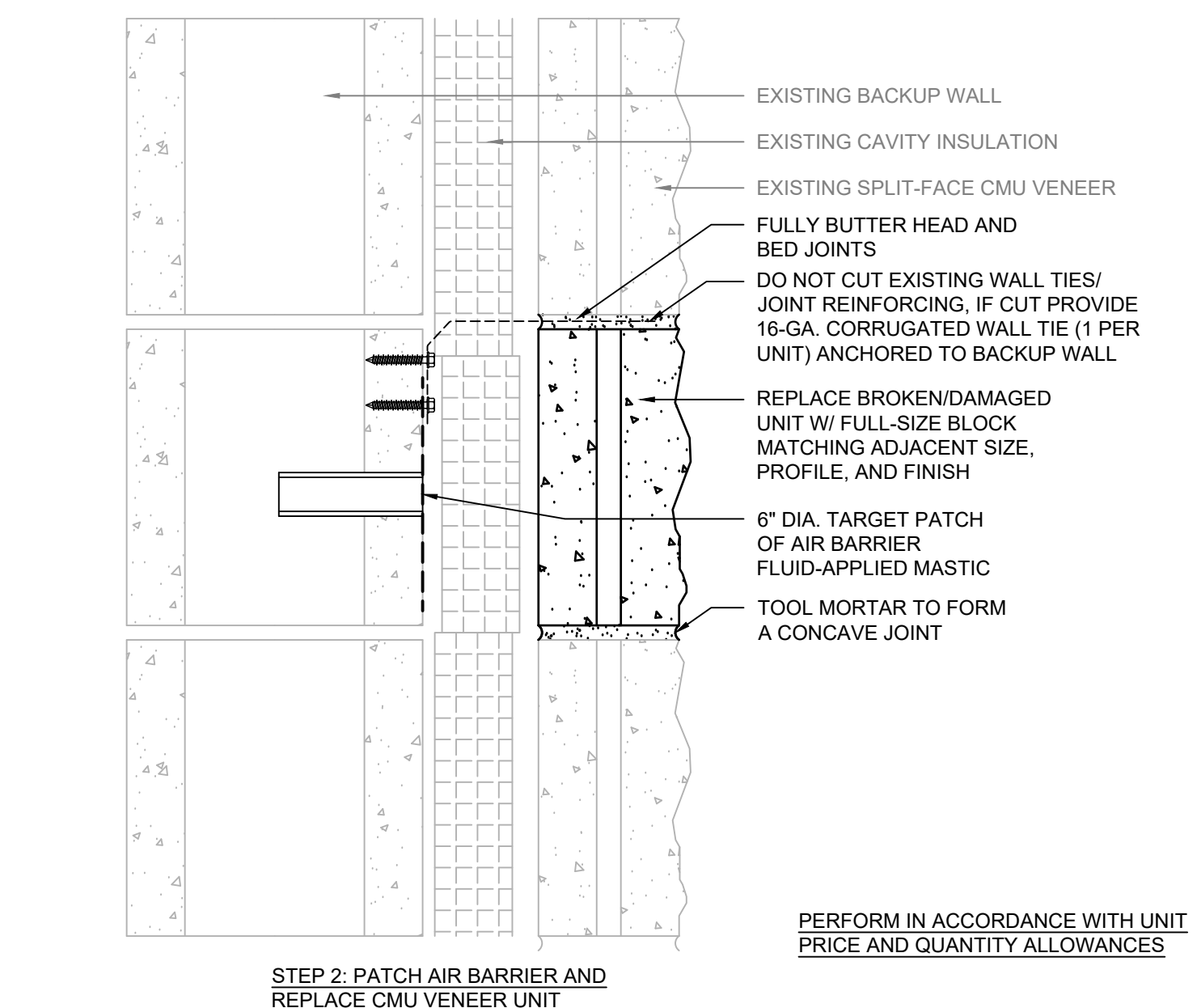
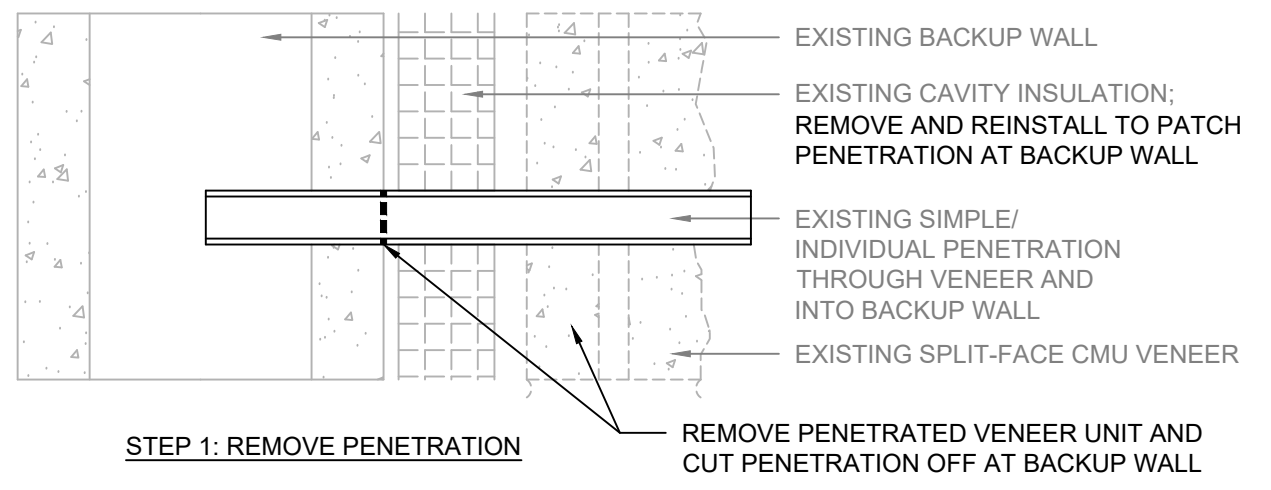

4 REMOVE ABANDONED PENETRATION
SCALE: 3" = 1'-0"

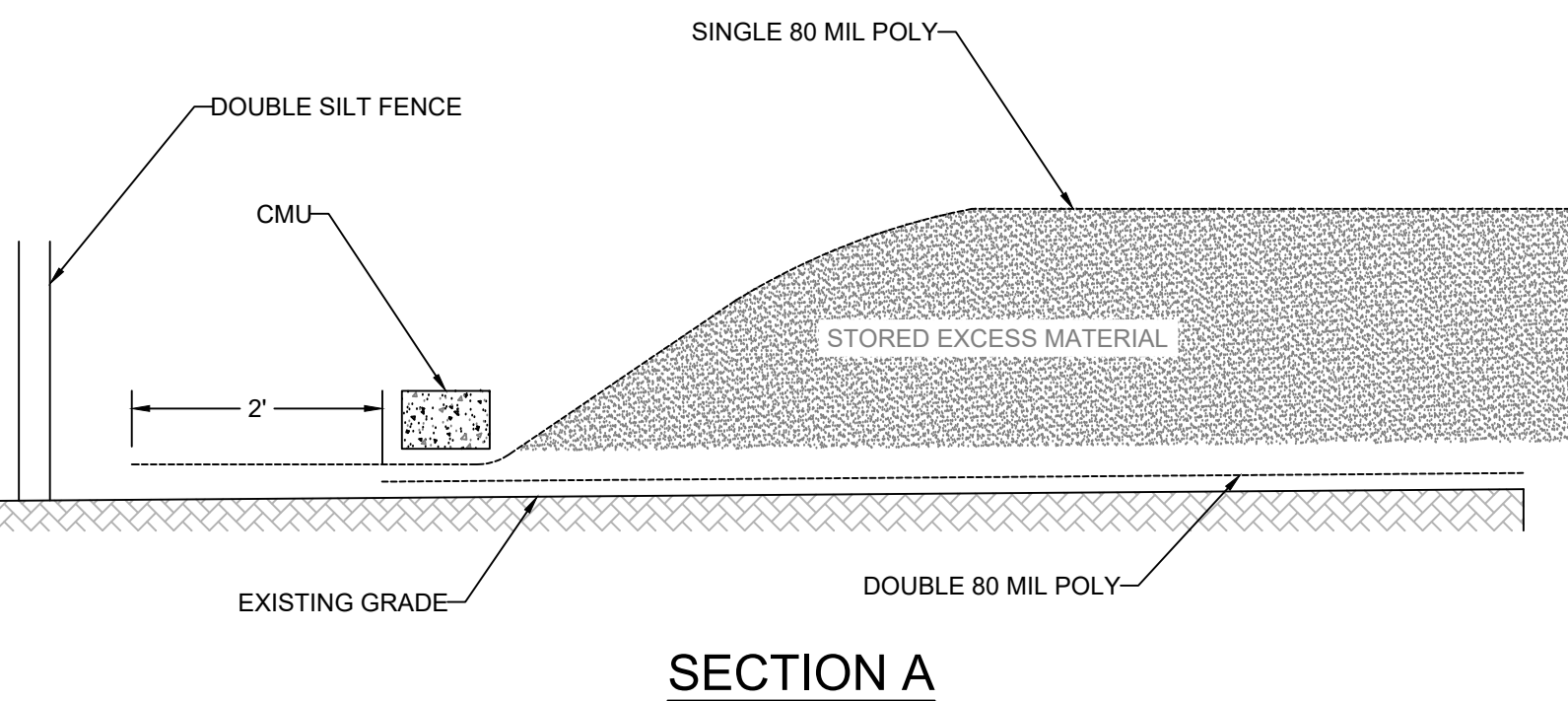
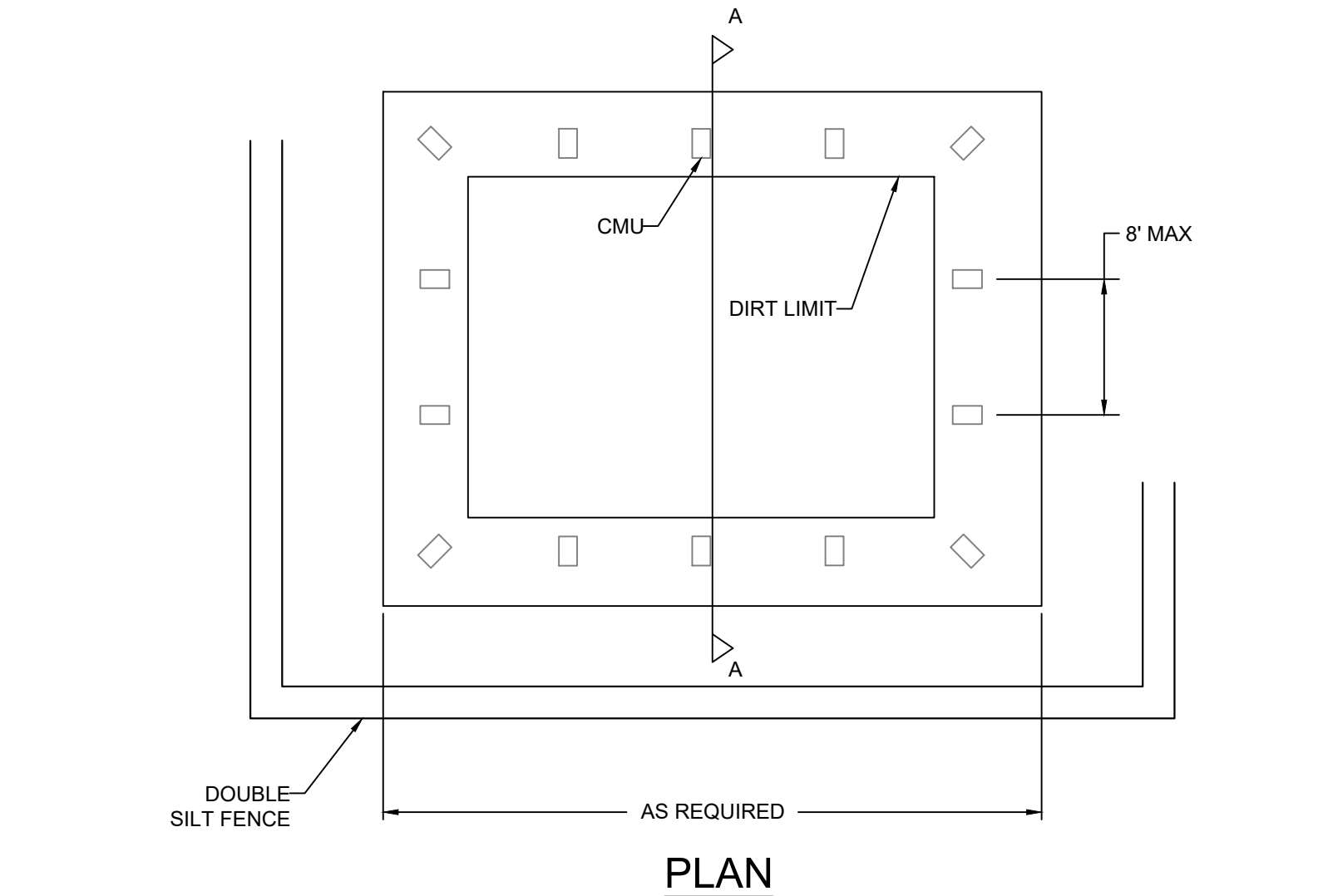

5 EXCESS MATERIAL STORAGE
SCALE: 3" = 1'-0"

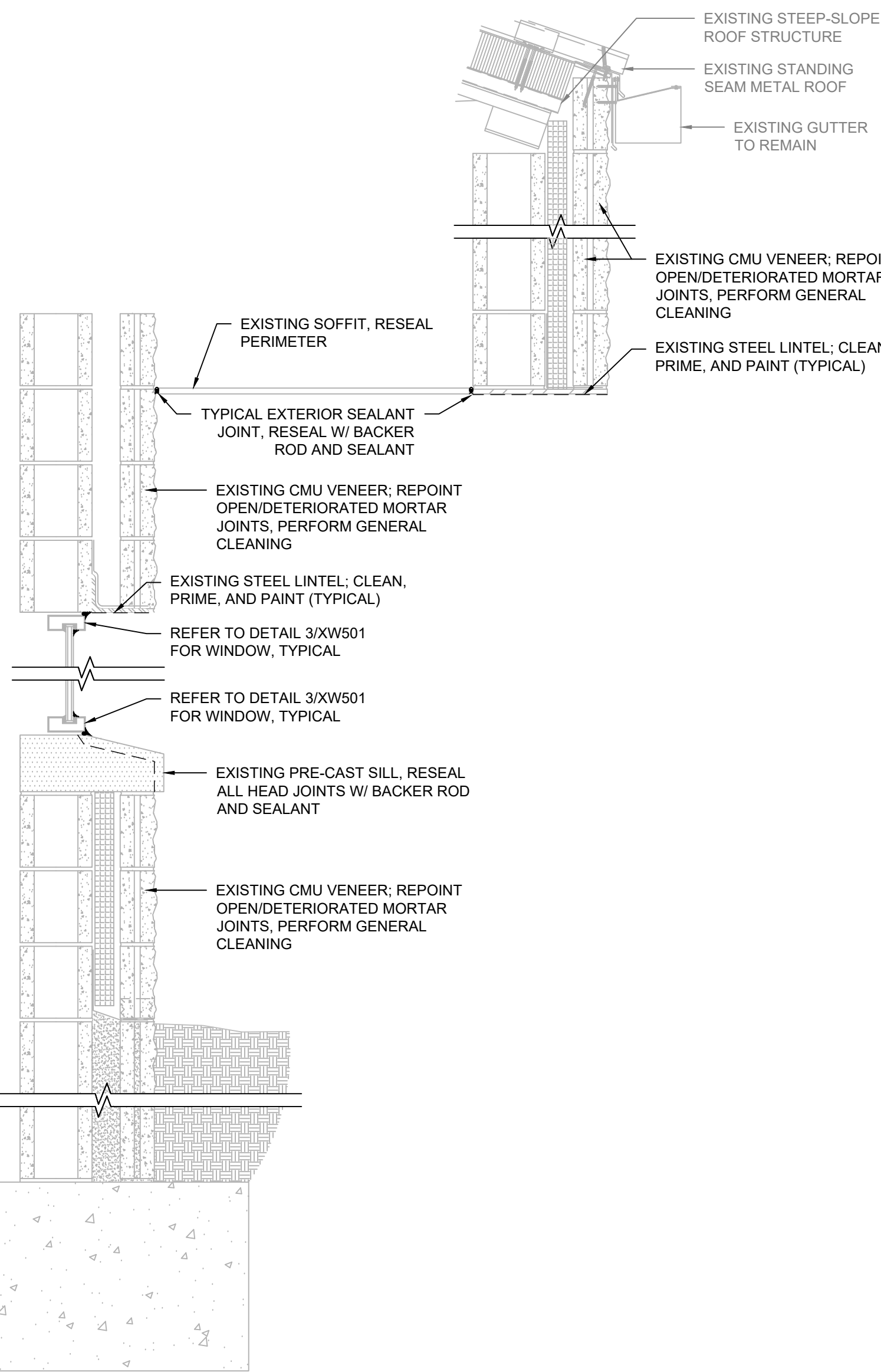

6 TYPICAL WALL SECTION @ WINDOWS
SCALE: 3" = 1'-0"

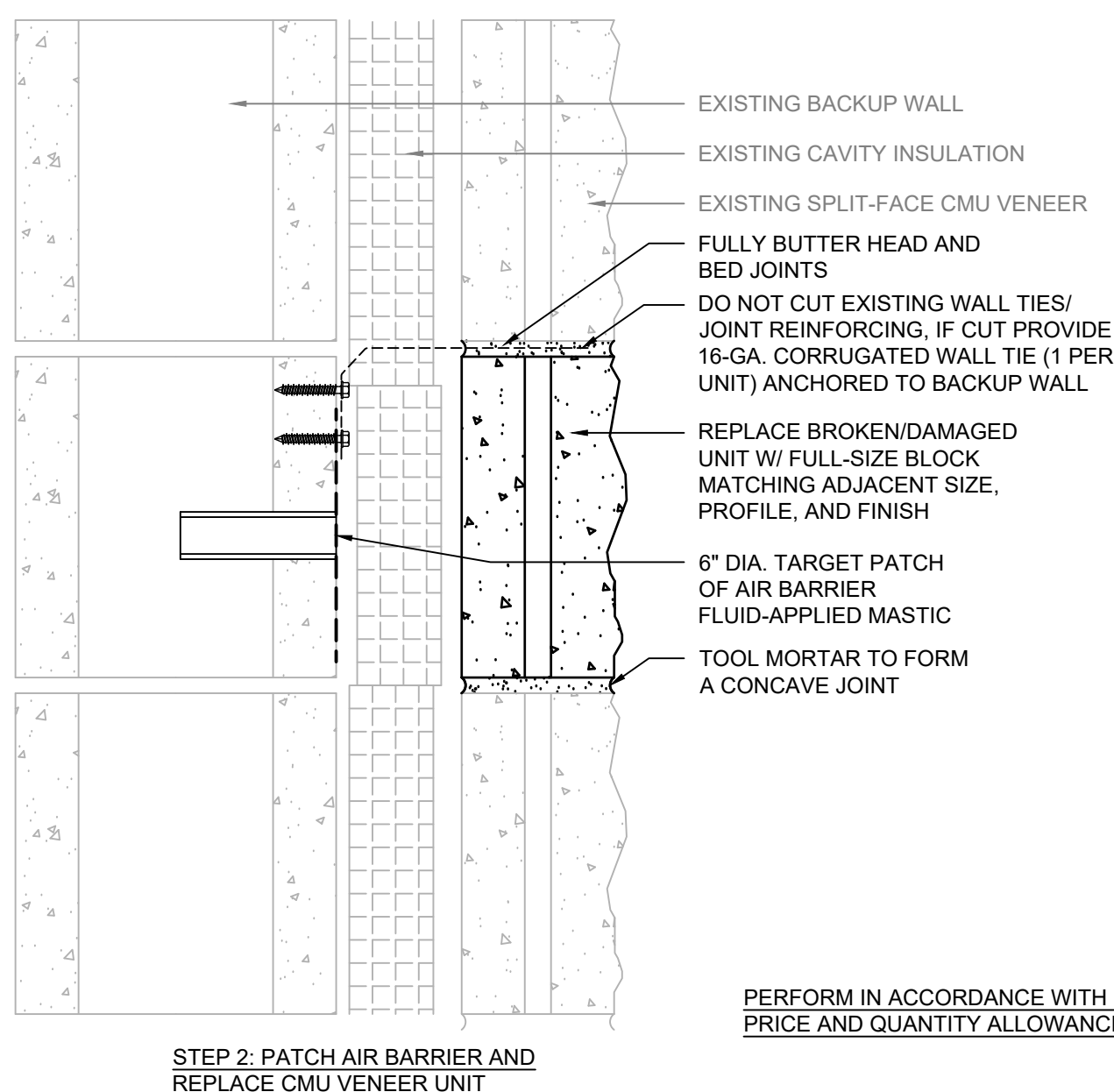

4 REMOVE ABANDONED PENETRATION
SCALE: 3" = 1'-0"

GENERAL NOTES:
1. THESE DOCUMENTS ARE THE PROPERTY OF REI ENGINEERS, INC. (REI) AND REI RETAINS ALL RIGHTS THEREIN, INCLUDING COPYRIGHTS. IT MAY ONLY BE USED IN A MANNER CONSISTENT WITH REI'S RIGHTS WHILE REI IS PROVIDING SERVICE FOR THE SPECIFIC PROJECT IDENTIFIED OR REFERRED TO HEREIN OR EXTENSIONS THERETO. IT MAY NOT BE USED FOR ANY OTHER PURPOSE EXCEPT WITH THE EXPRESS WRITTEN AGREEMENT OF, AND COMPENSATION TO, REI ENGINEERS, INC.
2. DIMENSIONS, DETAIL COMPONENTS AND EQUIPMENT PENETRATION LOCATIONS ARE FOR INFORMATION ONLY. CONTRACTOR IS RESPONSIBLE TO FIELD VERIFY ALL INFORMATION PROVIDED.
SHEET NOTES:
1. FOR DETAILS, LIGHT LINES REPRESENT EXISTING CONSTRUCTION TO REMAIN AND DARK LINES REPRESENT NEW COMPONENTS TO BE PROVIDED.



Engineering solutions for tomorrow®

9121 Anson Way | Suite 100
Raleigh, NC 27615

NORTH CAROLINA
ENGINEERING FIRM
LICENSE # C-1520

www.reiengineers.com

SEALS:



PROJECT NAME:
ORANGE COUNTY SCHOOLS

**NEW HOPE ELEMENTARY
SCHOOL BUILDING
ENCLOSURE
MAINTENANCE & REPAIR**

1900 HEW HOPE CHURCH ROAD
CHAPEL HILL, NC 27514

PROJ. NO:
023RAL-047

ISSUE:

NO.	DATE	DESCRIPTION
DD	11-20-23	DESIGN DEVELOPMENT
CD	12-12-23	CONTRACT DOCUMENTS (90%)
CD	04-10-24	ISSUED FOR BID

THIS LINE IS 1 INCH ON
THE ORIGINAL DRAWING
IF IT IS NOT 1 INCH ON THIS PAGE,
SCALE DRAWING ACCORDINGLY.

SHEET TITLE

DETAILS

DRAWING

XW502