

STATE OF NORTH CAROLINA/ASHEVILLE CITY SCHOOLS

REQUEST FOR PROPOSALS

#148-MAINT-009

PROJECT: Claxton Elementary Stair Railing Alterations PROJECT

USING AGENCY: Asheville City Schools

ISSUE DATE: 3/8/2022

Bids subject to the conditions made a part hereof will be received until **2:00 pm, Wednesday, March 23, 2022**, for furnishing all labor, materials, equipment, and services incidental and implied, for completion of the project described herein.

All Bids must be sent to the Purchasing Clerk at the address or email address provided below:

Asheville City Schools

Attn: Chris Pohlman, Purchasing

85 Mountain Street

Asheville, NC 28801

Phone: 828-350-6101

Fax: 828-251-4915

Email: chris.pohlman@acsgmail.net

Direct inquiries concerning this RFIB to:

Bidding and document questions:

Chris Pohlman, Purchasing Clerk

Office: 828-350-6101

Specifications and/or technical questions:

Tim Shelton, Maintenance Director

Mobile: 828-713-6430

THE PROCUREMENT PROCESS

The following is a general description of the process by which a firm will be selected to provide services.

1. Request for Informal Bids (RFIB), which refers to projects less than \$300,000, is issued to prospective contractors.
2. The deadline for written questions is three days prior to the due date.
3. Bids shall be signed and dated by an official authorized to bind the firm. Unsigned bids will not be considered.
4. All bids must be received by the issuing agency not later than the date and time specified on the cover sheet of this RFIB.
5. Bids will be evaluated according to completeness, content, experience with similar projects, ability of the offeror and its staff, and cost. Award of a contract to one offeror does not mean that the other bids lacked merit, but that, all factors considered, the selected bid was deemed most advantageous to the State.
6. Offerors are cautioned that this is a request for bids, not a request to contract, and the State/Asheville City Schools reserves the right to reject any and all unqualified offers when such rejection is deemed to be in the best interest of the State.

(NOTE: THE BID FORM MUST BE FULLY EXECUTED AND RETURNED FOR CONSIDERATION)

BID FORM

#148-MAINT-009

Claxton Elementary Stair Railing Alterations PROJECT

DUE DATE: 3/23/2022 by 2:00PM

The undersigned having carefully read and considered the terms and conditions of the Contract Documents for Claxton Elementary Stair Railing Alterations Project for Asheville City Schools, North Carolina, does hereby offer to perform such services on behalf of the District, of the type and quality and in the manner described, and subject to and in accordance with the terms and conditions set forth in the Contract Documents at the rates on the Bid Forms hereinafter set forth

Offeror: _____

Address: _____

City/State/Zip: _____ Phone: _____

Fed ID No: _____ MBE Status: _____ Fax: _____

Email: _____

By: (Signature) _____ Date: _____

Printed Name _____ Title: _____

Therefore, in compliance with this Request for Informal Bids, and subject to all conditions herein, the undersigned offers and agrees, if this bid is accepted, to furnish the subject services for a cost not to exceed:

\$ _____ Total

Additional Information, if applicable (attach extra sheets as needed): _____

END OF BID FORM

1. SCOPE OF WORK

The purpose of this solicitation is request Bids to install and fabricate new railing to existing stairwells at Claxton Elementary School. For the full Scope of Work, please see the architectural drawings, which can be found as Attachment A to this solicitation.

The Contractor shall furnish all labor, material, tools, equipment, transportation, insurance, and incidentals necessary to perform the work described herein. All work should be completed by

2. CONDITIONS

Each Bidder shall fully acquaint itself with conditions relating to the scope and restrictions attending the execution of the work under Contract. Bidders shall thoroughly examine and be familiar with the Specifications.

It is also expected that the Bidders will obtain information concerning the conditions at locations that may affect its work. The failure or omission of any Bidder to receive or examine any form, instrument, addendum or other document, or to acquaint itself with existing conditions, shall in no way relieve it of any obligations with respect to its Bid or to the Contract.

The Bidder shall make its own determination as to conditions and shall assume all risk and responsibility and shall complete the work in and under conditions it may encounter or create, without extra cost to Asheville City Schools.

3. QUALITY OF WORK

All work shall be performed in a good and professional manner by skilled, experienced workers. Asheville City Schools shall be responsible for determining the quality of work, and may notify the Contractor of the same.

4. LICENSES AND PERMITS

The Contractor shall obtain all licenses and permits required to execute contract by authorities that have jurisdiction.

5. SAFETY REGULATIONS:

The Contractor shall adhere to the rules, regulations, and interpretations of all state, federal, and local laws that pertain to workers and site safety. This to include OSHA 1910, General Construction, or those regulations mandated by these specifications.

6. NONDISCRIMINATION

The Contractor shall not discriminate against any person because of race, sex, age, creed, color, religion or national origin.

7. HISTORICALLY UNDERUTILIZED BUSINESSES

Pursuant to General Statute 143-48 and Executive Order #150, Asheville City Schools invited and encourages participation in this procurement process by businesses owned by minorities, women, disabled, disabled business enterprises and non-profit work centers for the blind and severely disabled.

8. INDEMNITY

The Contractor will indemnify and save harmless Asheville City Schools, its officers, agents, servants, and employees from and against any and all suits, actions, legal proceedings, claims, demands, damages, costs, expenses, and attorneys' fees to the extent resulting from a willful or negligent act or omission of the Contractor, its officers, agents, servants, and employees in the performance of this Contract; provided, however, that the Contractor shall not be liable for any suits, actions, legal proceedings, claims, demands, damages, costs,

expenses and attorneys' fees arising out of the award of this Contract or a willful or negligent act or omission of the Asheville City Schools, its officers, agents, servants and employees.

9. **INSURANCE**

If awarded a contract, the Bidder will provide a Certificate of Liability Insurance naming the District as additional insured. The issuing insurer must provide 30 days written notice to the District of the expiration of the insurance. As a minimum, the Contractor shall provide and maintain the following coverage and limits:

- Workers' Compensation Insurance, including Employer's Liability with limits of \$250,000 each accident. The Aggregate Limit will not be less than \$2,000,000.
- Property Damage Insurance, including Liability Coverage, with a per occurrence limit of \$1,000,000. The Aggregate Limit will not be less than \$2,000,000

Providing and maintaining adequate insurance coverage is a material obligation of the contractor and is of the essence of this contract. All such insurance shall meet all laws of the State of North Carolina. Such insurance coverage shall be obtained from companies that are authorized to provide such coverage and that are authorized by the Commissioner of Insurance to do business in North Carolina. The Contractor shall at all times comply with the terms of such insurance policies, and all requirements of the insurer under any such insurance policies, except as they may conflict with existing North Carolina laws or this contract. The limits of coverage under each insurance policy maintained by the contractor shall not be interpreted as limiting the contractor's liability and obligations under the contract.

To the extent permitted by law, all or any part of any required insurance coverages may be provided under a plan or plans of self-insurance. The coverages may be provided by the Contractor's parent corporation.

10. **TERMINATION:**

The District may terminate this agreement at any time by 15 days' notice in writing from the District to the Contractor. If the contract is terminated by the District as provided herein, the Contractor shall be paid for services satisfactorily completed, less payment or compensation previously made.

11. **SALES AND USE TAX**

The North Carolina General Assembly has amended the Statute to provide refunds of sales and use tax to local school units in accordance with the provisions of G.S. 105-164. 14(c) effective with tax paid on or after July 1, 1998.

These refunds are to include the "sales and use taxes paid by contractors on building materials, supplies, fixtures and equipment that become a part of or annexed to a building or structure that is owned or leased by the governmental entity and is being erected, altered or repaired for use by the governmental entity (G.S. 105-164.14)."

Sales and Use Tax Technical Bulletin Section 18-2F specifies: "To substantiate a refund claim for sales or use taxes paid on purchases of building materials, supplies, fixtures and equipment by its contractor, the claimant must secure from such contractor certified statements setting forth all of the following information:

- a. the date the property was purchased;
- b. the type of property purchased;
- c. the project for which the property was used;
- d. if the property was purchased in this State, the county in which it was purchased;
- e. if the property was not purchased in this State, the county in which the property was used; and
- f. the amount of sales and use taxes paid.

In the event the contractor makes several purchases from the same vendor, such certified statement must indicate the invoice numbers, the inclusive dates of the invoices, the total amount of the invoices and the State and local sales and use taxes paid thereon. Such statement must also include the cost of any tangible personal

3/2/2022 11:24:28 AM

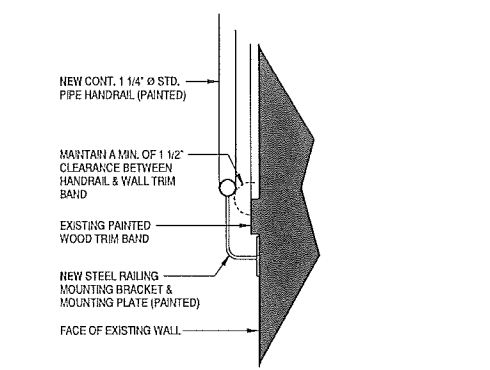

5 WALL MOUNT HANDRAIL DETAIL
A1.5 1 1/2" = 1'-0"

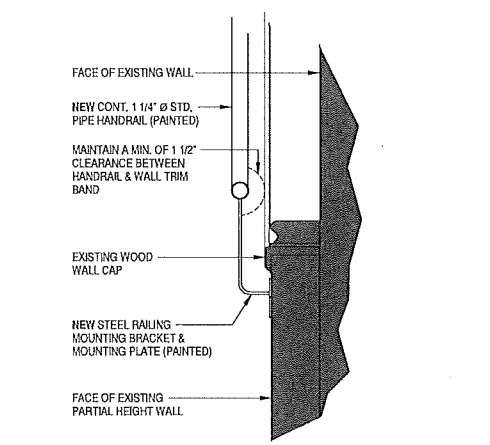

3 WALL MOUNT HANDRAIL DETAIL
A1.5 1 1/2" = 1'-0"

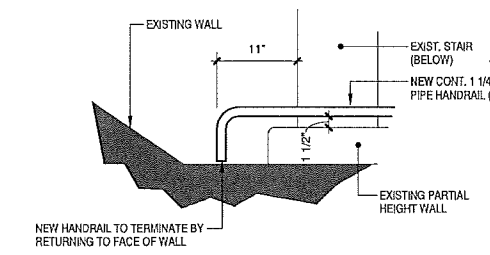

2 HANDRAIL EXTENSION
A1.5 1" = 1'-0"

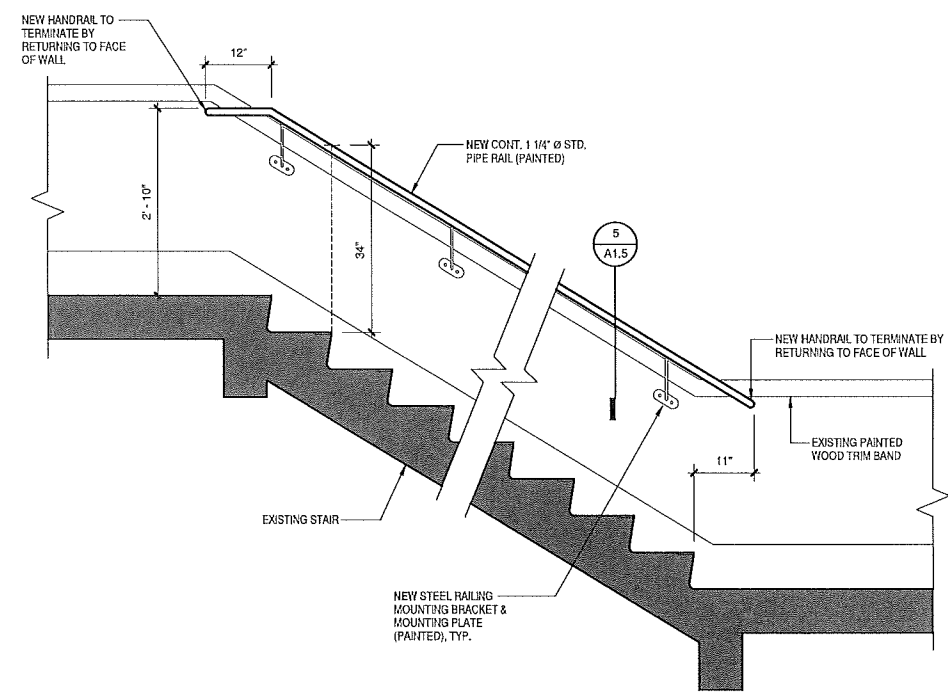

4 WALL MOUNTED RAILING ELEVATION
A1.5 3/4" = 1'-0"

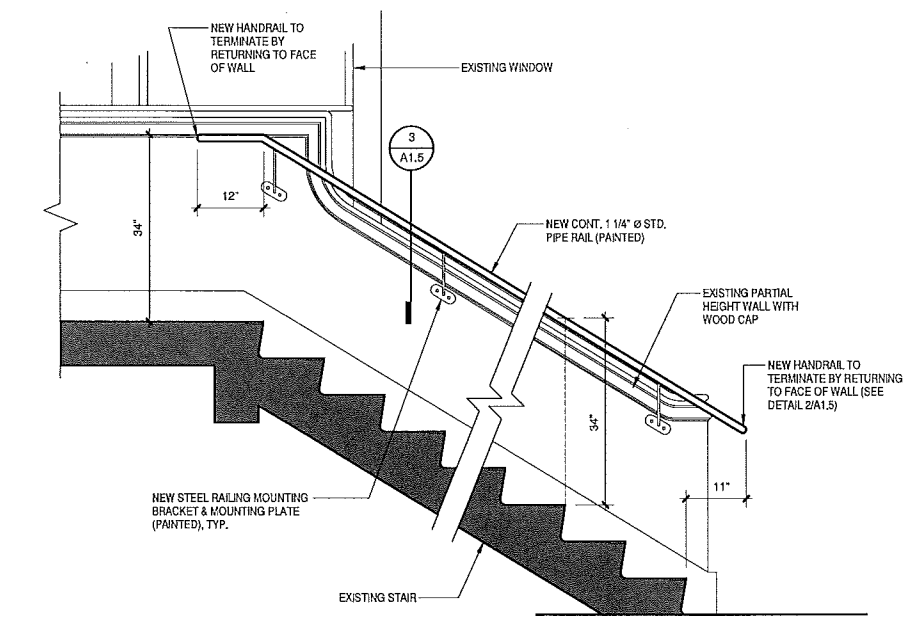

1 WALL MOUNTED RAILING ELEVATION - AT WOOD CAP
A1.5 3/4" = 1'-0"

195 Cone Avenue
Asheville, NC 28801
o: 828.254.1963
f: 828.253.3307
w: pfaarchitects.com

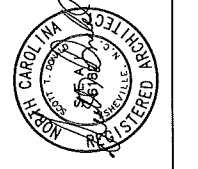
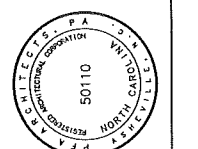

ASHEVILLE CITY SCHOOLS
CLAXTON ELEMENTARY STAIR
RAILING ALTERATIONS
241 MERRIMON AVE.
ASHEVILLE, NC 28801

Revisions	
No.	Date

Project Number: 2021-25
Date: 03-03-2022
Drawn by: CSR

DETAILS & DETAIL ELEVATIONS

Sheet Number:
A1.5