

SUMMER MATH

6th Grade

Multiplying Whole Numbers

1. Write the problem vertically
2. Multiply the ones digit of the bottom number by each of the digits in the top number, right to left
3. Bring down a zero and then multiply the tens digit of the bottom number by each digit in the top number, right to left
4. Bring down two zeros and repeat with the hundreds digit of the bottom number
5. Add up all of the products

ex: $3,481 \times 142$

$$\begin{array}{r} ^1 ^1 ^3 \\ 3,481 \\ \times 142 \\ \hline 6962 \\ + 139240 \\ + 348100 \\ \hline \boxed{494,302} \end{array}$$

Dividing Whole Numbers

1. Write out the long division problem with the first number (dividend) underneath the division symbol and the second number (divisor) to the left of the division symbol
2. Divide the divisor into the smallest part of the dividend it can go into and write the number of times it can go in on top of the division symbol
3. Multiply the number on top by the divisor and write the product under the number you divided into in step 2
4. Subtract your product from the number above it
5. Bring down the next digit of the dividend
6. Repeat steps 2-5 until there is nothing left to bring down.
7. If your last subtraction answer is not zero, write the remainder on top

ex: $6,425 \div 21$

$$\begin{array}{r} \boxed{305 \text{ R}20} \\ 21 \overline{) 6425} \\ \underline{-63} \\ 12 \\ \underline{-12} \\ 0 \\ \underline{-125} \\ 105 \\ \underline{-105} \\ 20 \end{array}$$

Find each product. Show your work.

1. 238×5	2. 832×156	3. $4,899 \times 67$	4. 756×300
5. 19×863	6. 188×732	7. $3,249 \times 173$	8. 609×840

Find each quotient. Show your work.

9. $876 \div 2$	10. $9,473 \div 5$	11. $396 \div 24$	12. $8,911 \div 45$
13. $700 \div 12$	14. $1,065 \div 15$	15. $2,737 \div 305$	16. $4,516 \div 22$

Solve each problem, showing all work.

17. Mrs. Kleim bought 5 boxes of 15 pencils to give to her students. If she has 26 students in her class, how many pencils can she give each student? How many pencils will she have left over?	18. Sarah and her 3 friends split a bag of candy evenly. They each ate 13 pieces of candy and there were 2 pieces leftover. How many pieces of candy were originally in the bag?
---	--

Rounding with Whole Numbers & Decimals

—	—	—	—	—	●	—	—	—
ten-thousands	thousands	hundreds	tens	ones		tenths	hundredths	thousandths

1. Keep all digits to the left of the place you are rounding the same
2. If the digit to the right of the rounding digit is less than 5, keep the rounding digit the same. If it's 5 or greater, increase the rounding digit by 1.
3. Change all places to the right of the digit you are rounding to 0. (Trailing zeros after the decimal are unnecessary)

ex: round 52.943 to the nearest tenth

52.9(4)3

less than 5, so the 9 stays the same

52.900

don't need trailing zeros after the decimal

52.9

Word Form & Expanded Form

1. Word Form: write the whole number in word form, translate the decimal to "and", & write the decimal as if it were a whole number, followed by the name of the place of the last digit
2. Expanded Form: write the value of each non-zero digit separately, with addition signs between them

ex: 209.315

two hundred nine and three hundred fifteen thousandths

$200 + 9 + 0.3 + 0.01 + 0.005$

Comparing & Ordering Decimals

1. Compare the whole number portions of the numbers. If they are different write $>$ for greater than or $<$ for less than.
2. If the whole numbers are the same, compare each digit to the right of the decimal point, one at a time until you find digits that are different. (If necessary, add zeros at the end of a decimal.)

ex: $13.702 \bigcirc 13.74$

$13 = 13$

$13.7 = 13.7$

$13.70 < 13.74$

So, $13.702 < 13.74$

Round the number 21,498.2536 to the nearest indicated place.

19. tenth	20. hundred	21. thousandth	22. one
23. thousand	24. hundredth	25. ten	26. ten-thousand

Complete the chart below.

Standard Form	Expanded Form	Word Form
3.962	27.	28.
29.	$100 + 2 + 0.09$	30.
31.	32.	Five thousand six hundred eighty-five and twelve hundredths
8,770.006	33.	34.
35.	$900 + 10 + 4 + 0.3 + 0.02 + 0.008$	36.
37.	38.	Two thousand nine and thirty-five thousandths

Compare each pair of numbers by writing $<$, $>$, or $=$ in the provided circle.

39. $0.046 \bigcirc 0.13$	40. $9.52 \bigcirc 90.13$	41. $24.13 \bigcirc 24.130$	42. $15.96 \bigcirc 15.906$
43. $0.964 \bigcirc 1$	44. $6.83 \bigcirc 6.825$	45. $7.256 \bigcirc 7.24$	46. $32.9 \bigcirc 3.290$

Order the numbers from least to greatest.

47. 6.86, 6.8, 7, 6.9, 6.827	48. 12.03, 1.2, 12.3, 1.203, 12.301
------------------------------	-------------------------------------

Adding & Subtracting Decimals

1. Write the problem vertically, lining up the decimal points
2. Add zeros, if necessary
3. Add or subtract the numbers as if they were whole numbers
4. Bring the decimal point straight down

ex: $12.8 - 1.52$

$$\begin{array}{r}
 12.\overset{7}{8}\overset{1}{0} \\
 - \quad 1.52 \\
 \hline
 11.\overset{1}{2}8
 \end{array}$$

Multiplying Decimals

1. Write the problem vertically with the numbers lined up to the right (decimals do NOT need to be lined up)
2. Ignore the decimal points and multiply the numbers as if they were whole numbers
3. Count the total number of decimal places in the two factors and put a decimal point in the product so that it has that same number of decimal places

ex: 3.24×0.8

$$\begin{array}{r}
 \overset{1}{3}.\overset{3}{2}4 \rightarrow 2 \text{ decimal places} \\
 \times \quad 0.8 \rightarrow 1 \text{ decimal place} \\
 \hline
 2592 \\
 \hline
 \text{3 decimal places} \\
 \downarrow \\
 \boxed{2.592}
 \end{array}$$

Dividing Decimals

1. Write the dividend under the division symbol and the divisor in front of the division symbol
2. Move the decimal in the divisor after the number and then move the decimal in the dividend the same number of places and bring it up
3. Ignore the decimal point and divide as if whole numbers
4. If there is a remainder, add a zero to the end of the dividend, bring it down, and then continue dividing until there is no remainder

ex: $32.3 \div 0.5$

$$\begin{array}{r}
 \boxed{64.6} \\
 0.5 \overline{) 32.3} \uparrow 0 \\
 \underline{-30} \\
 23 \\
 \underline{-20} \\
 30 \\
 \underline{-30} \\
 0
 \end{array}$$

Find each sum or difference. Show your work.

49. $8.74 + 10.36$	50. $37.4 - 8.55$	51. $12.9 + 105.67$	52. $450.89 - 213.33$
53. $24.1 + 3.74$	54. $14.76 - 9.8$	55. $622.85 + 53.49$	56. $67 - 14.06$

Find each product or quotient. Show your work.

57. 4.5×6	58. $144.8 \div 4$	59. 2.7×0.8	60. $6.2 \div 0.04$
61. 8.9×2.5	62. $15.8 \div 0.5$	63. 14.8×0.12	64. $16.2 \div 1.2$

Solve each problem, showing all work.

65. Ryan spent \$3.25 on lunch every day, Monday through Friday. If he had \$20 at the start of the week, how much money did he have left after Friday?	66. Three friends went out to lunch. The bill came to \$47.31. If they split the bill evenly, how much money does each friend owe?
---	--

Adding & Subtracting Fractions

1. Rename the fractions to equivalent fractions with common denominators
2. Add or subtract the numerators and keep the denominator the same
3. If mixed numbers, add or subtract the whole numbers
4. If possible, simplify the answer & change improper fractions to mixed numbers

ex: $4\frac{4}{9} + \frac{2}{3}$

$$\begin{array}{r} 4\frac{4}{9} \times \frac{1}{1} \quad \frac{4}{9} \\ + \quad \frac{2}{3} \times \frac{3}{3} \quad \frac{6}{9} \\ \hline \end{array}$$

$$4 \frac{10}{9} = \boxed{5 \frac{1}{9}}$$

Multiplying Fractions

1. Turn a whole number into a fraction by giving it a denominator of 1
2. Cross-simplify the fractions if possible
3. Multiply the 2 numerators and the 2 denominators
4. If possible, simplify the answer & change improper fractions to mixed numbers

ex: $6 \times \frac{2}{3}$

$$\begin{array}{r} 2 \cancel{6} \\ \frac{1}{1} \times \frac{2}{\cancel{3}} = \frac{4}{1} \end{array}$$

$$= \boxed{4}$$

Dividing Fractions

1. Turn a whole number into a fraction by giving it a denominator of 1
2. Keep the 1st fraction the same, change the division symbol to multiplication, and flip the 2nd fraction to its reciprocal
3. Multiply the 2 fractions
4. If possible, simplify the answer & change improper fractions to mixed numbers

ex: $12 \div \frac{1}{2}$

$$\frac{12}{1} \div \frac{1}{2}$$

↓

$$\frac{12}{1} \times \frac{2}{1} = \frac{24}{1} = \boxed{24}$$

Find each sum or difference. Show your work.

67. $\frac{7}{8} + \frac{5}{6}$	68. $\frac{9}{10} - \frac{1}{2}$	69. $\frac{3}{11} + \frac{2}{3}$	70. $\frac{11}{12} - \frac{13}{18}$
71. $4\frac{5}{9} + 7\frac{1}{3}$	72. $12\frac{9}{14} - 9\frac{3}{7}$	73. $3\frac{3}{5} + 2\frac{3}{4}$	74. $2\frac{2}{15} - 1\frac{2}{3}$

Find each product or quotient. Show your work.

75. $\frac{1}{6} \times \frac{3}{4}$	76. $6 \div \frac{1}{3}$	77. $15 \times \frac{2}{3}$	78. $\frac{1}{2} \div 3$
79. $\frac{1}{6} \times 10$	80. $\frac{1}{4} \div 2$	81. $\frac{5}{9} \times \frac{3}{20}$	82. $4 \div \frac{1}{5}$

Solve each problem, showing all work.

83. Jacqui ran $1\frac{1}{2}$ miles on Monday, Wednesday, and Friday and $\frac{3}{4}$ mile on Tuesday and Thursday. How far did she run in all?	84. Tyrell gave 3 packs of baseball cards to his friends. He gave each friend $\frac{1}{3}$ of a pack. How many friends got baseball cards?
--	---

The Metric System

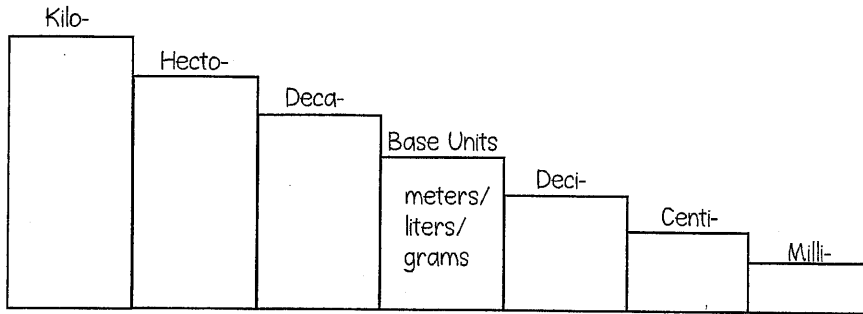

ex: $23 \text{ m} = \underline{\hspace{2cm}} \text{ cm}$

going from base unit step to centi- step, so need to move the decimal 2 places right

$$23.\underline{00}$$

$$= \boxed{2,300 \text{ cm}}$$

Determine the direction and count the number of steps it takes to get from the starting unit to the unit you are converting to and move the decimal point the same number of places in that direction.

The Customary System

Length	Weight	Capacity
1 ft = 12 in	1 lb = 16 oz	1 c = 8 fl oz
1 yd = 3 ft	1 T = 2,000 lb	1 pt = 2 c
1 mi = 5,280 ft		1 qt = 2 pt
		1 gal = 4 qt

ex: $18 \text{ c} = \underline{\hspace{2cm}} \text{ pt}$

cups are smaller units of measure than pints, so need to divide

$$18 \div 2 = \boxed{9 \text{ pints}}$$

To convert from a larger unit to a smaller unit, multiply. To convert from a smaller unit to a larger unit, divide.

Volume

Volume is the number of cubic units inside a figure.

Volume of Rectangular Prism = length x width x height

Volume of Irregular Figure: count cubic units

ex: find the volume

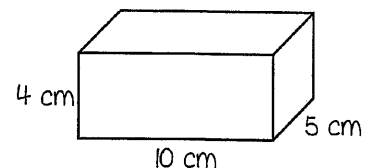

$$V = 4 \times 10 \times 5 = \boxed{200 \text{ cm}^3}$$

Convert each Metric measurement. Show your work.

85. 1.9 km = _____ m	86. 23 g = _____ mg	87. 350 ml = _____ kl
88. 0.07 kg = _____ cg	89. 6 cm = _____ m	90. 35 ml = _____ l

Convert each Customary measurement. Show your work.

91. 48 in = _____ ft	92. 6 pt = _____ c	93. 3 T = _____ lb
94. 1.5 mi = _____ ft	95. 32 pt = _____ gal	96. 32 oz = _____ lb

Find the volume of each figure. Show your work.

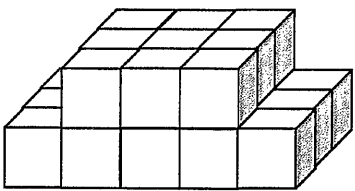
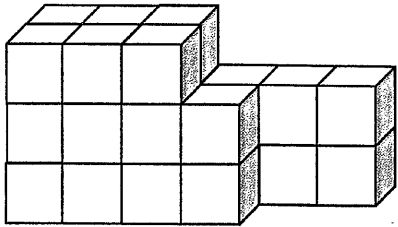
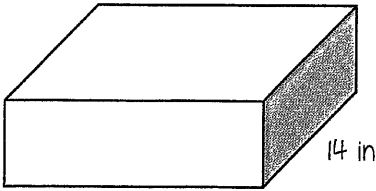
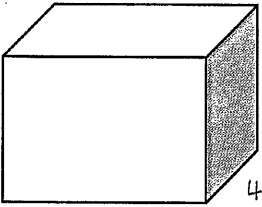
<p>97.</p> 	<p>98.</p> 
<p>99.</p>  <p>5 in</p> <p>14 in</p> <p>14 in</p>	<p>100.</p>  <p>5 cm</p> <p>8 cm</p> <p>4 cm</p>

Answer key

Find each product. Show your work.

1. 238×5 1,190	2. 832×156 129,792	3. $4,899 \times 67$ 328,233	4. 756×300 226,800
5. 19×863 16,397	6. 188×732 137,616	7. $3,249 \times 173$ 562,077	8. 609×840 511,560

Find each quotient. Show your work.

9. $876 \div 2$ 438	10. $9,473 \div 5$ 1,894 R3	11. $396 \div 24$ 16 R12	12. $8,911 \div 45$ 198 R1
13. $700 \div 12$ 58 R4	14. $1,065 \div 15$ 71	15. $2,737 \div 305$ 8 R297	16. $4,516 \div 22$ 205 R6

Solve each problem, showing all work.

17. Mrs. Kleim bought 5 boxes of 15 pencils to give to her students. If she has 26 students in her class, how many pencils can she give each student? How many pencils will she have left over? 2 pencils/student 23 pencils leftover	18. Sarah and her 3 friends split a bag of candy evenly. They each ate 13 pieces of candy and there were 2 pieces leftover. How many pieces of candy were originally in the bag? 54 pieces of candy
---	--

Round the number 21,498.2536 to the nearest indicated place.

19. tenth 21,498.3	20. hundred 21,500	21. thousandth 21,498.254	22. one 21,498
23. thousand 21,000	24. hundredth 21,498.25	25. ten 21,500	26. ten-thousand 20,000

Complete the chart below.

Standard Form	Expanded Form	Word Form
3.962	27. $3 + 0.9 + 0.06 + 0.002$	28. three and nine hundred sixty-two thousandths
29. 102.09	$100 + 2 + 0.09$	30. one hundred two and nine hundredths
31. 5,685.12	32. $5,000 + 600 + 80 + 5 + 0.1 + 0.02$	Five thousand six hundred eighty-five and twelve hundredths
8,770.006	33. $8,000 + 700 + 70 + 0.006$	34. eight thousand seven hundred seventy and six thousandths
35. 914.328	$900 + 10 + 4 + 0.3 + 0.02 + 0.008$	36. nine hundred fourteen and three hundred twenty-eight thousandths
37. 2,009.035	38. $2,000 + 9 + 0.03 + 0.005$	Two thousand nine and thirty-five thousandths

Compare each pair of numbers by writing $<$, $>$, or $=$ in the provided circle.

39. $0.046 < 0.13$	40. $9.52 < 90.13$	41. $24.13 = 24.130$	42. $15.96 > 15.906$
43. $0.964 < 1$	44. $6.83 > 6.825$	45. $7.256 > 7.24$	46. $32.9 > 3.290$

Order the numbers from least to greatest.

47. 6.86, 6.8, 7, 6.9, 6.827 6.8, 6.827, 6.86, 6.9, 7	48. 12.03, 1.2, 12.3, 1.203, 12.301 1.2, 1.203, 12.03, 12.3, 12.301
--	--

Find each sum or difference. Show your work.

49. $8.74 + 10.36$ 19.1	50. $37.4 - 8.55$ 28.85	51. $12.9 + 105.67$ 118.57	52. $450.89 - 213.33$ 237.56
53. $24.1 + 3.74$ 27.84	54. $14.76 - 9.8$ 4.96	55. $622.85 + 53.49$ 676.34	56. $67 - 14.06$ 52.94

Find each product or quotient. Show your work.

57. 4.5×6 27	58. $144.8 \div 4$ 36.2	59. 2.7×0.8 2.16	60. $6.2 \div 0.04$ 155
61. 8.9×2.5 22.25	62. $15.8 \div 0.5$ 31.6	63. 14.8×0.12 1.776	64. $16.2 \div 1.2$ 13.5

Solve each problem, showing all work.

65. Ryan spent \$3.25 on lunch every day, Monday through Friday. If he had \$20 at the start of the week, how much money did he have left after Friday? \$3.75	66. Three friends went out to lunch. The bill came to \$47.31. If they split the bill evenly, how much money does each friend owe? \$15.77
---	---

Find each sum or difference. Show your work.

67. $\frac{7}{8} + \frac{5}{6}$ $1\frac{17}{24}$	68. $\frac{9}{10} - \frac{1}{2}$ $\frac{2}{5}$	69. $\frac{3}{11} + \frac{2}{3}$ $\frac{31}{33}$	70. $\frac{11}{12} - \frac{13}{18}$ $\frac{7}{36}$
71. $4\frac{5}{9} + 7\frac{1}{3}$ $11\frac{8}{9}$	72. $12\frac{9}{14} - 9\frac{3}{7}$ $3\frac{3}{14}$	73. $3\frac{3}{5} + 2\frac{3}{4}$ $6\frac{7}{20}$	74. $2\frac{2}{15} - 1\frac{2}{3}$ $\frac{7}{15}$

Find each product or quotient. Show your work.

75. $\frac{1}{6} \times \frac{3}{4}$ $\frac{1}{8}$	76. $6 \div \frac{1}{3}$ 18	77. $15 \times \frac{2}{3}$ 10	78. $\frac{1}{2} \div 3$ $\frac{1}{6}$
79. $\frac{1}{6} \times 10$ $1\frac{2}{3}$	80. $\frac{1}{4} \div 2$ $\frac{1}{8}$	81. $\frac{5}{9} \times \frac{3}{20}$ $\frac{1}{12}$	82. $4 \div \frac{1}{5}$ 20

Solve each problem, showing all work.

83. Jacqui ran $1\frac{1}{2}$ miles on Monday, Wednesday, and Friday and $\frac{3}{4}$ mile on Tuesday and Thursday. How far did she run in all? 6 miles	84. Tyrell gave 3 packs of baseball cards to his friends. He gave each friend $\frac{1}{3}$ of a pack. How many friends got baseball cards? 9 friends
---	--

Convert each Metric measurement. Show your work.

85. $1.9 \text{ km} = \underline{\hspace{2cm}} \text{ m}$ 1,900	86. $23 \text{ g} = \underline{\hspace{2cm}} \text{ mg}$ 23,000	87. $350 \text{ ml} = \underline{\hspace{2cm}} \text{ kl}$ 0.00035
88. $0.07 \text{ kg} = \underline{\hspace{2cm}} \text{ cg}$ 7,000	89. $6 \text{ cm} = \underline{\hspace{2cm}} \text{ m}$ 0.06	90. $35 \text{ ml} = \underline{\hspace{2cm}} \text{ l}$ 0.035

Convert each Customary measurement. Show your work.

91. $48 \text{ in} = \underline{\hspace{2cm}} \text{ ft}$ 4	92. $6 \text{ pt} = \underline{\hspace{2cm}} \text{ c}$ 12	93. $3 \text{ T} = \underline{\hspace{2cm}} \text{ lb}$ 6,000
94. $1.5 \text{ mi} = \underline{\hspace{2cm}} \text{ ft}$ 7,920	95. $32 \text{ pt} = \underline{\hspace{2cm}} \text{ gal}$ 4	96. $32 \text{ oz} = \underline{\hspace{2cm}} \text{ lb}$ 2

Find the volume of each figure. Show your work.

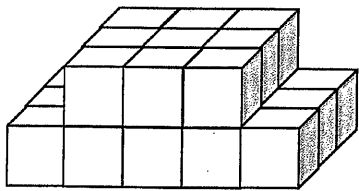
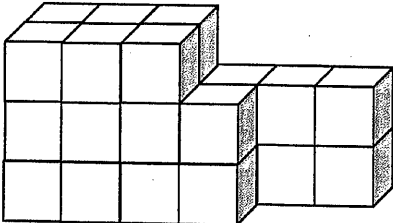
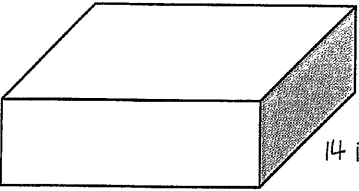
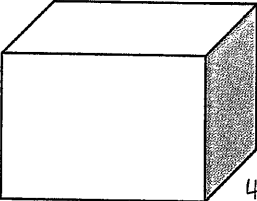
97.  24 cubic units	98.  26 cubic units
99.  980 cubic inches	100.  160 cubic centimeters