

**BOARD OF TRUSTEES**

CARLA CORONA  
CHARLES HUGHES  
JILL MCGRADY  
MIGUEL SANCHEZ IV  
DONITA J. WINN

**ADDENDUM #2**  
**BID #16/23-24**

**Outdoor Weight Room Equipment (8 Sites)**

**May 27, 2024**

**ADMINISTRATION**

GREG NEHEN  
Superintendent  
SHANDELYN WILLIAMS  
Deputy Superintendent  
DR. CHRIS GRADO  
Assistant Superintendent  
Educational Services  
KRISTINA RAMOS  
Assistant Superintendent  
Human Resources

THE FOLLOWING REVISIONS AND CLARIFICATIONS SHALL BE MADE TO THE BIDDING REQUIREMENTS AND CONTRACT DOCUMENTS. REVISE AND AMEND THE DOCUMENTS FOR THE ABOVE NAMED PROJECT IN ACCORDANCE WITH THIS ADDENDUM. THE BID SHALL REFLECT THESE ADDENDUM CHANGES AND EACH BIDDER SHALL MAKE REFERENCE IN THEIR BID TO THIS ADDENDUM.

ALL BIDDING REQUIREMENTS AND CONTRACT DOCUMENTS SHALL APPLY TO THIS ADDENDUM AS ORIGINALLY INDICATED IN THE APPLICABLE PORTION OF THE CONTRACT DOCUMENTS, UNLESS OTHERWISE MODIFIED BY THIS ADDENDUM.

1. Please revise equipment attachment list from Addendum 1 to include the following attachments for the Octagon, or "Dynamic Fitness Half-Rack-"
  - 2 x WOD BOX WING
  - 12 x MONKEY BAR \*Not Required if unavailable on approved alternate
  - 2 x PULLUP HANDLES
  - 16 x WEIGHT HORN
  - 4 x TORSO / LANDMINE TRAINER
  - 4 x BATTLE ROPE EYE STAINLESS STEEL WITH BATTLE ROPE
  - 8pr x STANDARD CATCH RACK
  - 8pr x EXTENDED CATCH RACK
  - 16 x ADJUSTER TEETH UNIT STAINLESS STEEL

2. Submittal for “Dynamic Fitness Half Rack” and “Dynamic Fitness Specialty Bench” are approved, provided statement from Manufacturer is included confirming application of “Alestia SD” Super Durable Powder Coat prior to installation.
3. Bid Due date Extended to June 7, 2024 at 3:00pm. Bids will be opened publicly on Friday, June 7, 2024, at the District Office at 3:00 PM as calculated by the clock designated by the District or its representative as the bid clock or as soon as practicable thereafter. A Bid received after the stated date and time will be returned to the Bidder unopened.
4. Project Duration Extended to 112 days. Project Completion date to be on or before September 30, 2024
5. Liquidated damages increased to \$1,500/day



# DOUBLE HALF RACK DP SHORT BASE

**Approved**  
with confirmation  
of application of  
"Alesta SD" Super  
Durable Powder  
Coat

Dynamic Fitness & Strength's premium rack series doubles both plate storage and workout capacity with this top-of-the-line rack. Maximize your floor space with this Double Half Rack featuring dual storage posts while its heavy-gauge steel frame endures whatever your heaviest lifters put it through. The U-shaped base provides additional stand-alone support and the 2-inch lock notch anchor points offer settings just right for users of any size. Also available with single post weight storage.

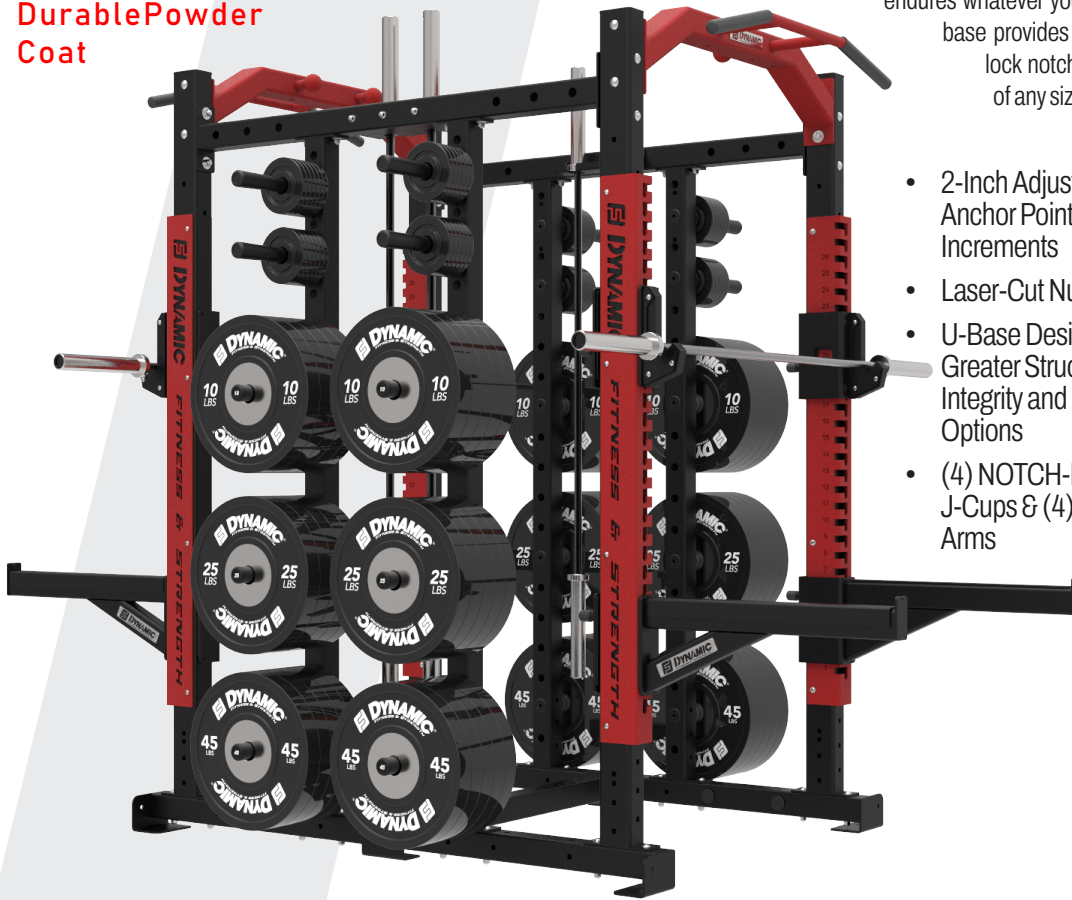

**Features:**

- 2-Inch Adjustable Anchor Point Increments
- Laser-Cut Numbering
- U-Base Design for Greater Structural Integrity and Storage Options
- (4) NOTCH-LOCK J-Cups & (4) 28" Safety Arms
- (2) Multi-Grip Chin Station
- (4) Barbell Storage
- (20) Plate Storage Pegs
- Intensive Multi-Stage Pretreatment Process for Long-Lasting Powder-Coat Finish
- Space Saving Compact Footprint

700105SB  
features powder-coated upright wraps

Bumper plates and Barbells shown for display purposes only. Not included with unit.

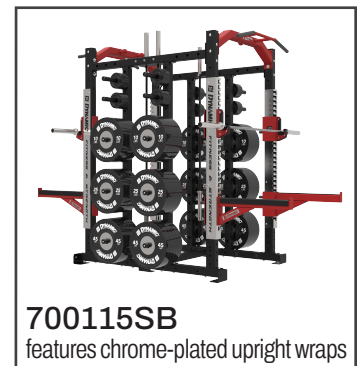

700115SB  
features chrome-plated upright wraps



**A full line of add-on equipment:**

MORE STRENGTH PER SQUARE FOOT™

Increase the functionality of your rack with these and more Ultra Pro accessories & attachments.

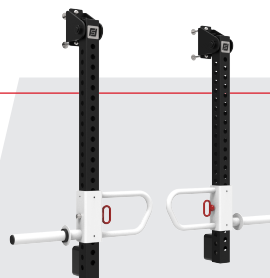

Athletic Training Arms

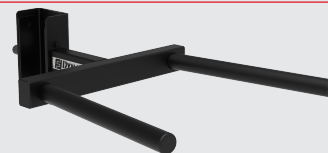

Dip Station



Landmine

Bolt-on Band Pegs

700105SB/700115SB

Ultra Pro™ Series

# DOUBLE HALF RACK DP SHORT BASE

## Specifications:

**FRAME:** 5" X 3" 7-Gauge Structural Steel Tubing

**WEIGHT:** 1009 LBS

**DIMENSIONS:** 75" W x 95" H x 122" L

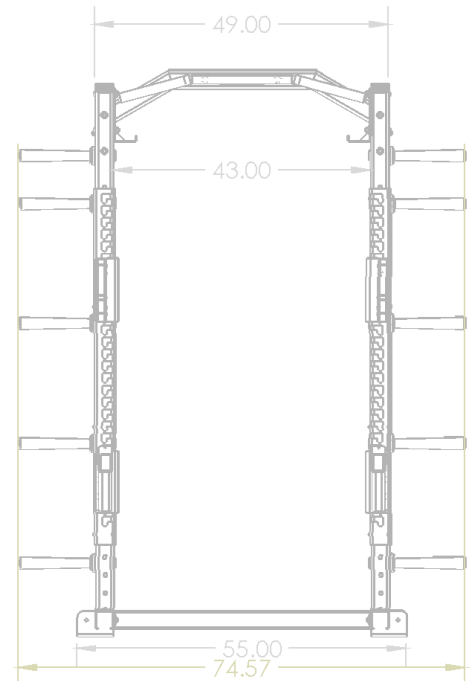
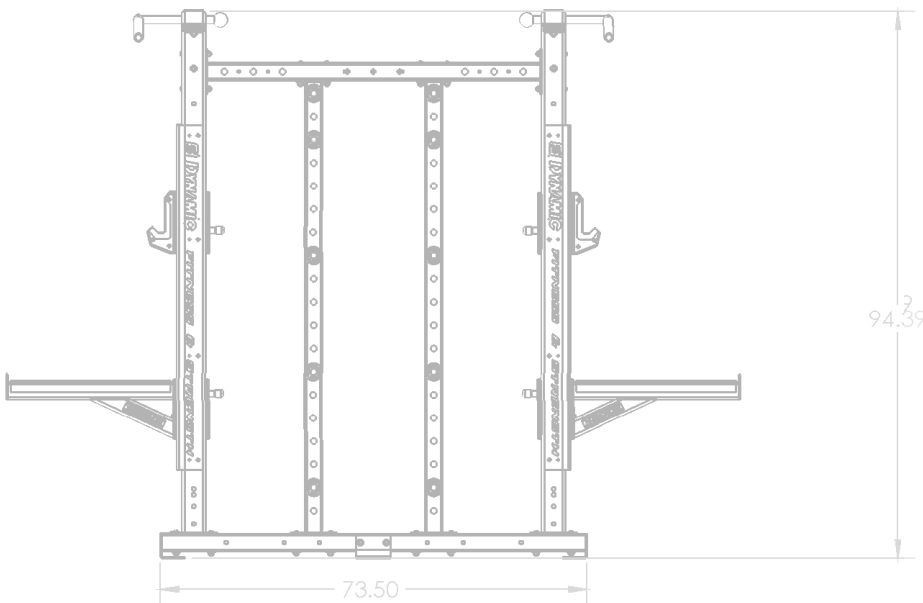
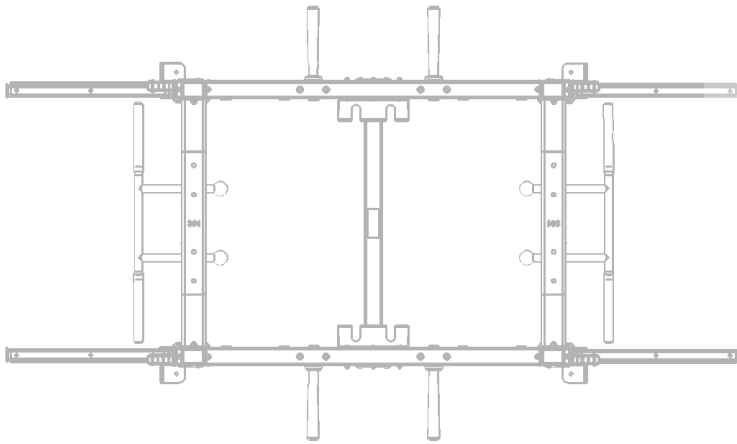
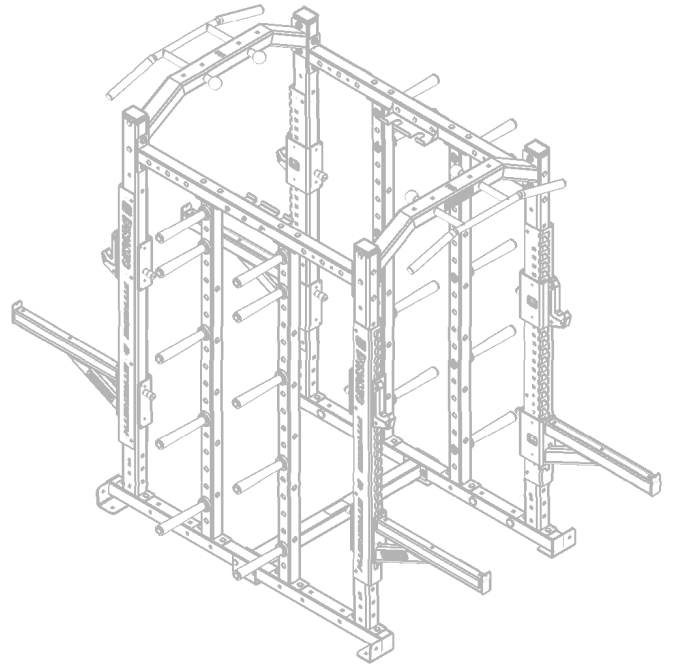



# Specialty Bench Line FID BENCH

Approved  
with confirmation  
of application of  
"Alesta SD" Super  
Durable Powder  
Coat

The Dynamic FID (Flat/Incline/Decline) Bench features multiple back and seat settings and ankle support pads to offer flat, incline, vertical and decline pressing. This bench can also be used for prone supported rowing and posterior work with dumbbells or kettlebells. The rolling base provides convenient transport.

## Features:

- 12" Wide Dual-Pivoting Pads
- 6 Back Positions (-15°/0°/20°/35°/50°/75°)
- 3 Easy-to-Adjust Seat Levels
- Ankle Support Pads
- Rolling Base for Easy Transport
- Protective Rubber Feet
- Custom Color Pad and Custom Printed Slip Cover Options Also Available
- Intensive Multi-Stage Pretreatment Process for Long-Lasting Powder-Coat Finish



**PICK YOUR COLORS!**  
Textured or gloss powder coated finish  
**COLOR-MATCHING ALSO AVAILABLE.**

**A full line of benches**

**MORE STRENGTH PER SQUARE FOOT™**

We have a full line of Utility, Olympic and Specialty Benches.



Utility Bench



Decline Bench



Lumbar Utility Bench

718063

# Specialty Bench Line FID BENCH

## Specifications:

**FRAME:** 2" X 3" 11-Gauge Structural Steel Tubing

**WEIGHT:** 154 LBS

**DIMENSIONS:** 25" W x 19" H x 65" L

**BENCH PAD WIDTH:** 12" Dual Pivoting Pads

