

# ANTELOPE VALLEY JOINT UNION HIGH SCHOOL DISTRICT PROJECT MANUAL

Bid# 15/23-24

Desert Winds, Eastside, and R. Rex Parris High Schools Re-Roofs

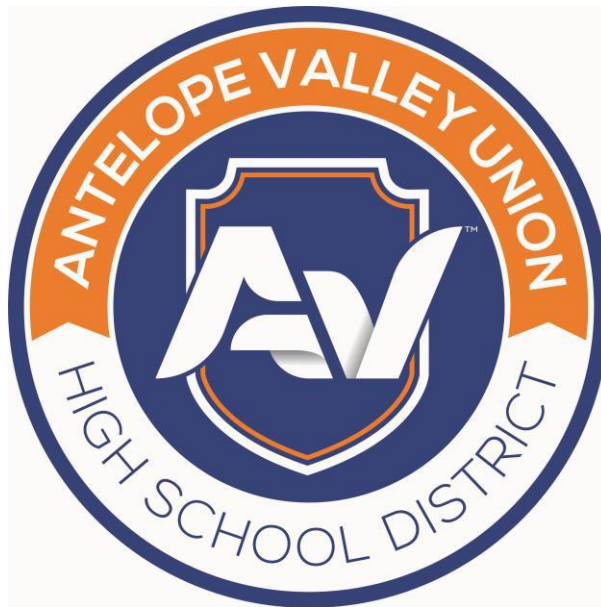

ANTELOPE VALLEY JOINT UNION HIGH SCHOOL DISTRICT  
District Administrative Offices  
176 Holston Dr  
Lancaster, CA 93535-4531  
Los Angeles County, California  
(661) 948-7655

Date of Bid Opening: **May 31, 2024**

Time of Bid Opening: **2:00pm**

**Bid# 15/23-24-Desert Winds, Eastside, and R. Rex Parris High Schools Re-Roofs**

**Project Manual Index**

<b><u>Section</u></b>	<b><u>Page</u></b>
• Cover Page	1
• Project Manual Index	2
• Notice to Bidders	3-5
• Instructions to Bidders	6-14
• General Conditions	15-129
• Agreement	130-136
• Bid Form	137-139
• Bid Bond	140-141
• Payment Bond	142-143
• Performance Bond	144-145
• Designation of Sub Contractors	146-148
• Drug Free Workplace	149
• Escrow Agreement	150-153
• Alcohol & Tobacco Free Campus	154
• Demand for Payroll Records	155
• Notice of Existence of Asbestos	156
• DIR Verification	157
• Fingerprinting	158-163
• Iran Contracting Act	164
• Non-Collusion Declaration	165
• Prime Bidders Certification	166-167
• Prime Bidder Good Faith Worksheet	168-169
• Sufficient Funds Declaration	170
• Workers Compensation Certificate	171
• Roof Project Certificate	172
• Scope of Work/NRC Re-Roof Specs	173-217
• AVUHSD CWA	218-259

## **NOTICE TO BIDDERS**

Notice is hereby given that the Antelope Valley Joint Union High School District (hereinafter referred to as "District") will receive sealed bids on or before the date and time stated for the Bid Opening for:

### **Bid# 15/23-24 Desert Winds, Eastside, and R. Rex Parris High Schools Re-Roofs**

as per drawings and specifications which may now be obtained from:

[L.Montesdeoca@avhsd.org](mailto:L.Montesdeoca@avhsd.org)

[www.PQBids.com](http://www.PQBids.com)

[www.avdistrict.org](http://www.avdistrict.org)

All bids shall be made and presented on the Bid Form furnished by the District. Each bid must conform and be responsive to the Contract Documents.

Bids will be received for **Bid# 15/23-24 Desert Winds, Eastside, and R. Rex Parris High Schools Re-Roofs**

The lowest bid shall be determined: On the amount of the base contract

Time of completion for the Project shall be **(NINETY) (90)** Calendar days from the date established in the District's Notice to Proceed.

Bids will be sealed and filed in the Business Office of the District

### **ANTELOPE VALLEY JOINT UNION HIGH SCHOOL DISTRICT**

**176 Holston Dr**

**Lancaster, California 93535**

**Attention: Monica Garcia**

### **Bid#15/23-24 Desert Winds, Eastside, and R. Rex Parris High Schools Re-Roofs**

on **Friday, May 31, 2024** on or before **(2:00pm)** on the clock designated by the District. Facsimile (FAX) copies of the bid will not be accepted. The District has not adopted any methods or procedures to receive bids via the Internet pursuant to Public Contract Code section 1601. Any bids sent to the District via electronic mail will not be considered.

Bids will be opened publicly on **May 31, 2024, at 176 Holston Dr. Lancaster, CA 93535** at **2:00 PM** as calculated by the clock designated by the District or its representative as the bid clock or as soon as practicable thereafter. A Bid received after the stated date and time will be returned to the Bidder unopened.

**A mandatory Pre-bid conference will be held on Monday, May 20, 2024 at R. Rex Parris High School – 38801 Clock Tower Dr., Palmdale, CA 93550 at 9:00 am followed by Desert Winds and Eastside High Schools. We will meet in front of the Administration Office.**

The District will require the successful Bidder to achieve the minimum goal of 3% DVBE (Disabled Veteran Business Enterprises) established in the bidding documents or to provide acceptable evidence of good faith efforts to do so. The DVBE documents must be sealed

and filed in the Business Office of the District before on **(05/31/2024)** on or before **(2:00PM)**, at which time the bids (including the DVBE forms) will be opened in public.

Bids must be accompanied by a bidder's bond, cashier's check, or certified check for at least ten percent (10%) of the amount of the base bid and made payable to the District. If a bid bond is used, it must be issued by an Admitted Surety (an insurance organization authorized by the Insurance Commissioner to transact the business of insurance in the State of California during this calendar year), which shall be given as a guarantee that the bidder will enter into a Contract if awarded the Work and will be declared forfeited, paid to, or retained by the District as liquidated damages if the bidder refuses or neglects to enter into the Contract provided by the District after being requested to do so.

Bids must be accompanied by an executed Fingerprinting Notice and Acknowledgment.

The successful bidder will be required to furnish a Payment (Labor and Material) Bond in the amount of one hundred percent (100%) of the Contract Sum, and a Faithful Performance Bond in the amount of one hundred percent (100%) of the Contract Sum, said bonds to be secured from an Admitted Surety (an insurance organization authorized by the Insurance Commissioner to transact the business of insurance in the State of California during this calendar year), and satisfactory to the District.

The successful bidder will be required to furnish insurance as set forth in the Contract Documents.

The successful bidder will be allowed to substitute securities or establish an escrow in lieu of retainage, pursuant to Public Contract Code Section 22300, and as described in the Agreement Between District and Contractor and General Conditions.

The District will not consider or accept any bids from contractors who are not licensed to do business in the State of California, in accordance with the California Public Contract Code, providing for the licensing of contractors. In accordance with Section 3300 of said Code, the bidder shall have a Class "**C-39**" license and shall maintain that license in good standing through Project completion and all applicable warranty periods. District reserves the right to reject any bid if a listed subcontractor is not licensed at the time bidder's bid is submitted to District.

The Director of Industrial Relations of the State of California, in the manner provided by law, has ascertained the general prevailing rate of per diem wages and rate for legal holidays and overtime work. The Contractor must pay for any labor therein described or classified in an amount not less than the rates specified. Copies of the schedules of rates are available on the Internet ([www.dir.ca.gov/DLSR/PWD](http://www.dir.ca.gov/DLSR/PWD)) and are on file at the District's business office and are available to any interested party on request. In accordance with section 1773.2 of the California Labor Code, the Contractor shall post a copy of the determination of prevailing rate of wages at each job site. The schedule of per-diem wages is based upon a working day of eight (8) hours. The rate for holiday and overtime work shall be at time plus one-half. The Contractor and any subcontractor(s) shall pay not less than the specified prevailing rates of wages to all workers employed by them in the execution of the contract.

No contractor or subcontractor may be awarded a contract for public work on a public works project unless registered with the Department of Industrial Relations pursuant to Labor Code section 1725.5. No contractor or subcontractor may be listed on a bid proposal for a public



## **INSTRUCTIONS TO BIDDERS**

**Bid# 15/23-24-Desert Winds, Eastside, and R. Rex Parris High Schools Re-Roofs**  
(AVUHSD)

**SECURING DOCUMENTS:** Please contact Leslie Montesdeoca, AVUHSD Facilities Development Technician, for Document request. LMontesdeoca@avhsd.org

### **PREQUALIFICATION:**

This Contract is not subject to prequalification.

**RETENTION:** The Owner will withhold retention of 5% from all progress payments.

### **REGISTRATION:**

For all projects over Twenty-Five Thousand Dollars (\$25,000), the Owner shall not accept any bid or enter into any contract without proof of the bidder's current registration to perform public work under Labor Code section 1725.5.

For all projects over Twenty-five Thousand Dollars (\$25,000), the bidder shall not accept any subbid or enter into any subcontract without proof of the subcontractor's current registration to perform public work under Labor Code section 1725.5.

The District will not consider or accept any bids from contractors who are not licensed to do business in the State of California, in accordance with the California Public Contract Code, providing for the licensing of contractors. In accordance with Section 3300 of said Code, the bidder shall have a Class "C-39" license and shall maintain that license in good standing through Project completion and all applicable warranty periods. District reserves the right to reject any bid if a listed subcontractor is not licensed at the time bidder's bid is submitted to District.

### **PRE-BID CONFERENCES OR SITE VISITS:**

Mandatory pre-bid Job Walk will be held on **Monday, May 20, 2024 at 9:00AM at R. Rex Parris High School** – 38801 Clock Tower Dr., Palmdale, CA 93550 followed by Desert Winds and Eastside High Schools. Meet outside at the front entrance to the school.

### **BUILDER'S RISK COVERAGE:**

For the purpose of builders risk coverage (see General Conditions Article 11), the project is not being solely funded by revenue bonds.

### **USE OF FEDERAL FUNDS:**

Federal funds are being used by Owner for the Contract.

## **BIDS:**

Bids to receive consideration shall be made in accordance with the following instructions:

1. Bids shall be made on a form therefor, obtained from the Architect or Owner. Bids not made on the proper form shall be disregarded. Numbers must be stated in words and figures, and the signatures of all individuals must be in longhand.
2. No bid will be considered which makes exceptions, changes, or in any manner makes reservations to the terms of the drawings or specifications. If prequalification is required for this Contract, no bid will be accepted from a contractor that has not been prequalified.
3. Questions regarding documents, discrepancies, omissions, or doubt as to meanings shall be referred immediately to the Architect who will send written instructions clarifying such questions to each bidder. Oral responses will not be binding on the Owner or Architect or any Construction Manager.
4. Each bid must give the full business address of the bidder and be signed by bidder with bidder's usual signature. Bids by partnerships must furnish the full name of all partners and must be signed in the partnership name by a general partner with authority to bind the partnership in such matters, followed by the signature and designation of the person signing. The name of the person signing shall also be typed or printed below the signature. Bids by corporations must be signed with the legal name of the corporation, followed by the name of the state of incorporation and by the signature and designation of the chairman of the board, president or any vice president, and then followed by a second signature by the secretary, assistant secretary, the chief financial officer or assistant treasurer. All persons signing must be authorized to bind the corporation in the matter. The name of each person signing shall also be typed or printed below the signature. Satisfactory evidence of the authority of the officer signing on behalf of a corporation shall be furnished.
5. Pursuant to the provisions of Sections 4100 to 4114, inclusive, of the Public Contract Code of the State of California, which are hereby incorporated and made a part hereof and these Instructions to Bidders, every bidder shall set forth in its bid (using the Owner's form for Designation of Subcontractors:
  - A. The name and location of the place of business, the California contractor license number, and for all projects over Twenty-Five Thousand Dollars (\$25,000), the public works contractor registration number, of each subcontractor who will perform work or labor or render service to the bidder in or about the construction of the work or improvement, or a subcontractor licensed by the State of California who, under subcontract to the bidder, specially fabricates and installs a portion of the Work or improvement according to detailed drawings contained in the plans and specifications, in an amount in excess of one-half ( $\frac{1}{2}$ ) of one percent (1%) of the bidder's total

bid. An inadvertent error in listing a California contractor's license number shall not be grounds for filing a bid protest or for considering the bid nonresponsive if the bidder submits the corrected contractor's license number to the Owner within 24 hours after the bid opening, or any continuation thereof, so long as the corrected contractor's license number corresponds to the submitted name and location for that subcontractor.

- B. The portion of the Work which will be done by each such subcontractor. If the bidder fails to specify a subcontractor for any portion of the Work to be performed under the Contract in excess of one-half (½) of one percent (1%) of the bidder's total bid, the bidder agrees to perform that portion itself. The successful bidder shall not, without the consent of the Owner:
- 1) Substitute any person as subcontractor in place of the subcontractor designated in the original bid.
  - 2) Permit any subcontract to be assigned or transferred or allow it to be performed by anyone other than the original subcontractor listed in the bid.
  - 3) Sublet or subcontract any portion of the Work in excess of one-half (½) of one percent (1%) of the total bid as to which the original bid did not designate a subcontractor.
6. The Director of Industrial Relations of the State of California, in the manner provided by law, has ascertained the general prevailing rate of per diem wages and the rate for legal holidays and overtime work. The Contractor must pay for any labor therein described or classified in an amount not less than the rates specified. Copies of the required rates are on file at the Owner's business office and are available to any interested party on request.
7. All bids must be accompanied by a completed Non-Collusion Declaration and Sufficient Funds Declaration (Labor Code § 2810). All bids must be accompanied by an executed Fingerprinting Notice and Acknowledgment; Iran Contracting Act Certification, if required by law (see form); Workers' Compensation certification; Contractor Questionnaire, if required (see paragraph 13; and DVBE Certification of Participation and Good Faith Worksheet, if DVBE is required (see paragraph 10).
8. Bids must be accompanied by a certified check, cashier's check, or bidder's bond, for an amount not less than ten percent (10%) of the amount of the base bid, made payable to the order of the Owner. If a bidder's bond accompanies the bid, said bond shall be secured by an Admitted Surety (an insurance organization authorized by the Insurance Commissioner to transact business of insurance in the State of California during this calendar year). The surety insurer must, unless otherwise agreed to by Owner in writing, at the time of issuance of the bond, have a rating not



lower than “A-” as rated by A.M. Best Company, Inc. or other independent rating companies. Owner reserves the right to approve or reject the surety insurer selected by Contractor and to require Contractor to obtain a bond from a surety insurer satisfactory to the Owner. Said check or bond shall be given as a guarantee that the bidder will enter into the Contract if awarded the Work, and in case of refusal or failure to enter into said Contract, the check or bond, as the case may be, shall be payable to the Owner and retained as liquidated damages.

9. Bids shall be sealed and filed as indicated in the Notice to Bidders. Irrespective of how a bidder chooses to deliver the bid and other documents to the Owner, the bidder is responsible for ensuring that the bid and other documents are actually received at the location designated in the Contract Documents for receipt of the bid and other documents prior to the time for the bid opening. Bids and other documents for any reason not actually received at the designated location prior to the time for the bid opening shall not be opened or considered.
10. **THIS CONTRACT X IS \_ IS NOT SUBJECT TO THE DVBE REQUIREMENTS OF EDUCATION CODE SECTION 17076.11.**
11. Contractor shall maintain its license in good standing through Completion of the Work and all applicable warranty periods. Owner reserves the right to reject any bid as nonresponsive if bidder or any subcontractor is not licensed in good standing from the time the bid is submitted to Owner up to award of the Contract, whether or not the bidder listed the subcontractor inadvertently, or if a listed subcontractor’s license is suspended or expires prior to award of the Contract. Owner also reserves the right the reject any bid as nonresponsive if a listed subcontractor’s license is not in good standing to perform the work for which it is listed from the time of submission of the bidder’s bid to award of the Contract.
12. The Owner reserves the right to waive any irregularity and to reject any or all bids.
13. No Contractor Questionnaire is required to be submitted with a bid on this Contract.
14. This project is bound by the District’s Community Workforce Agreement (CWA) with the Los Angeles and Orange County Building and Construction Trade Councils, as referenced in the prospective bid documents.
15. To summarize, each bid for the Contract must include the following documents:
  - a. Bid form, including proof of signers’ authority.
  - b. Bid security
  - c. Designation of Subcontractors
  - d. Non-Collusion Declaration
  - e. Sufficient Funds Declaration
  - f. Fingerprinting Notice and Acknowledgement
  - g. Iran Contracting Act Certification, if required by law

- h. Workers' Compensation Certification
- i. Contractor Questionnaire, if required
- j. DVBE Participation Certification, if required
- k. DVBE Good Faith Worksheet, if required
- l. Proof of registration per Labor Code §1725.5.
- m. Contractor Cert. Re Alcohol and Tobacco free Campus
- n. Demand for Payroll Records
- o. Notice of Existence of Asbestos
- p. Drug Free Workplace Cert
- q. Roof Project Certificate

### **WITHDRAWAL OF BIDS:**

Bids may be withdrawn by bidders prior to the time fixed for the submittal of bids or any authorized postponement thereof. A successful bidder shall not be relieved of the bid unless by consent of the Owner or bidder's recourse to Public Contract Code §5100 et seq.

Unless otherwise required by law, no bidder may withdraw its bid for a period of sixty (60) days after the date set for the opening thereof or any extension thereof. The owner reserves the right to take more than sixty (60) days to make a decision regarding rejection of the bid or award of the Contract.

### **OPENING OF BIDS:**

Opening of bids shall be as soon after the hour set as will be possible; opening and declaration to be as set forth in the Notice to Bidders. Any and all bidders will be permitted to attend.

### **EXAMINATION OF CONTRACT DOCUMENTS AND SITE:**

Before submitting a bid, bidders shall examine the drawings, read the specifications, the form of Agreement between Contractor and Owner, and the other Contract Documents. Bidders shall visit the site of the proposed Work, examine the building, or buildings, if any, and any work that may have been done thereon. Bidders shall fully inform themselves of all conditions, in, at, and about the site, the building or buildings, if any, and any work that may have been done thereon.

Pursuant to Public Contract Code section 1104: 1) bidders shall not be required to assume responsibility for the completeness and accuracy of architectural or engineering plans and specifications, except on clearly designated design build projects; 2) however, bidders shall be required to review architectural or engineering plans and specifications prior to submission of their bids and to report any errors and omissions to the Architect or Owner; and 3) the review shall be confined to the bidder's capacity as a bidder and not as a licensed design professional.

## **BID PROTESTS:**

All bid protests must comply with the following, or they shall be rejected as invalid:

1. The protest shall be in writing;
2. The protest shall be filed and received no later than 4:00 p.m. on the fourth (4th) business day after the deadline for submittal of the bids;
3. The protest shall set forth in detail all grounds for the protest, including all facts, supporting documentation, legal authorities and arguments in support of the bid protest;
4. Before the bid protest deadline, the protesting party shall transmit the complete bid protest, including all documentation, to all other parties having a potential interest that may be adversely affected by the outcome of the protest, including but not limited to all other bidders who may have a reasonable prospect of losing or obtaining an award of the Contract depending on the outcome of the protest; and
5. All factual contentions must be supported by competent, admissible and credible evidence.

The procedures and time limits set forth in this section for bid protests are strictly construed and are protesting party's sole and exclusive remedy in the event of a bid protest. Protesting party's failure to strictly comply with these procedures and time limits shall constitute a waiver of any right to further pursue the bid protest, including but not limited to the presentation of a Government Code claim or legal proceedings. Any matter not set forth in the protest, including any ground for the protest or any evidence supporting a ground for the protest, shall be deemed waived.

A protesting party may not rely on the bid protest submitted by another protesting party, but must timely pursue its own bid protest.

Owner shall review a bid protest that was not rejected for failing to comply with the above procedures. Any final decision on such a bid protest shall be made by the Governing Board.

## **FORM OF AGREEMENT BETWEEN OWNER AND CONTRACTOR:**

The form of Agreement between Owner and Contractor which the successful bidder will be required to execute, if awarded the Work, is a part of this Bid Package.

## **ADDENDA OR BULLETINS:**

Any addenda or bulletins, issued during the time of bidding, shall form a part of the drawings and specifications loaned to the bidder for the preparation of its bid, shall be covered in the bid, and shall be made a part of the Contract Documents. All addenda or bulletins shall be signed by the Architect and approved by the Division of State Architect.

**EVIDENCE OF RESPONSIBILITY:**

Upon the request of Owner, a bidder shall submit promptly to the Owner or its designee satisfactory evidence showing the bidder's financial resources, the bidder's experience in the type of work required by the Owner, the bidder's organization available for the performance of the Contract, and any other required evidence of the bidder's or its subcontractor's qualifications to perform the proposed Contract. The Owner may consider such evidence before making its decision awarding the proposed Contract. Failure to submit evidence of the bidder's or its subcontractors' responsibility to perform the proposed Contract may result in rejection of the bid.

**AWARD OF CONTRACT:**

Rejection of any or all bids, to contract work with whomever and in whatever manner, to abandon work entirely, and/or to waive any informality in receiving of bids is reserved as the right of the Owner. Before the Contract is awarded, the Owner may at its sole discretion, require from the proposed Contractor on the Project further evidence of the reasonable qualifications of such contractor to faithfully, capably, and reasonably perform such proposed Contract and may consider such evidence before making its decision on the award of such proposed Contract.

The Contract shall be awarded to the lowest responsible and responsive bidder as interpreted by the Owner under California law and as specified herein and shall be entered into by the successful bidder within ten (10) days after mailing, faxing or delivery of the Notice of Award of Contract. Owner reserves the right, without any liability, to cancel the award of any bid for any reason at any time before the full execution of the Agreement between Owner and Contractor.

**EXECUTION OF AGREEMENT BETWEEN OWNER AND CONTRACTOR:**

The Agreement between Owner and Contractor shall be signed by the successful bidder in as many originals as the Owner deems necessary and returned, together with the required Contract bonds, insurance certificates, additional insured endorsement, declarations page, a Public Contract Code section 3006(a) Roof Project Certification, if required, Drug-Free Workplace Certification, and Independent Contractor Student Contact Form, within ten (10) days after receipt of the notice of award of the Contract. If the ten (10) day period would expire after the date for commencement of the Work, Contractor must submit the documents before the date of commencement of the Work. If the successful bidder does not comply with this paragraph, Owner may revoke and/or cancel the award to the successful bidder and award the Contract to the next lowest bidder, or may otherwise proceed as allowed by law. A Roof Project Certification is not required if (1) the Owner has ADA (average daily attendance) of 2,500 or less, or (2) the Work involves repair of 25% or less of the roof, or costs \$21,000 or less.

## **CONTRACT BONDS:**

As required by the Contract Documents, two bonds, as itemized below and in the forms presented in these Contract Documents, shall be furnished by the successful bidder on the Project at the time of entering into the Contract and filed with the Owner before the successful bidder commences any Work. They shall be in the form of surety bonds issued by Admitted Surety insurers (an insurance organization authorized by the Insurance Commissioner to transact business of insurance in the State of California during this calendar year). The surety insurers must, unless otherwise agreed to by Owner in writing, at the time of issuance of the bond, have a rating not lower than "A-" as rated by A.M. Best Company, Inc. or other independent rating companies. Owner reserves the right to approve or reject the surety insurers selected by Contractor and to require Contractor to obtain bonds from surety insurers satisfactory to the Owner.

**Performance Bond** in the amount of one hundred percent (100%) of the Contract Sum to insure Owner during construction, and for one year after Completion and during any warranty or guaranty period, against faulty or improper materials or workmanship and to assure Owner of full and prompt performance of the Contract.

**Payment Bond** (Labor and Material) in the amount of one hundred percent (100%) of the Contract Sum in accordance with the laws of the State of California to secure payment of any and all claims for labor and materials used or consumed in performance of this Contract.

## **SUBSTITUTION OF MATERIALS:**

The Contractor must ensure that the proposed substitutions by the Contractor or its subcontractors are submitted to the Owner and Architect a minimum of **Five (5)** calendar days prior to the bid opening for review and possible approval of any equipment or materials thought to be equal to or better than those specified in the drawings or specifications. An addendum may be issued prior to bid opening, including all equipment and materials deemed equivalent to those specified and approved by the Architect. Submittals shall include comparative spec-data of the specified equipment or material and the proposed substitution as set forth in the Contract Documents. Submittals without this information will be automatically rejected.

## **PAYMENTS:**

Payments to the Contractor on account of the Contract shall be made in accordance with the terms of the Contract Documents.

## **TAXES:**

The Owner is generally exempt from payment of Federal Excise Tax on materials. The Owner will furnish exemption certificates to the Contractor to be used to obtain materials

ordinarily subject to Federal Excise Tax without payment of the tax. Bidder shall deduct Federal Excise Taxes from their bid prices before submitting bids, so that such taxes will not be included in the Contract Sum.

**EARLY TERMINATION:**

Notwithstanding any provision herein to the contrary, if for any fiscal year of this Contract the governing body of the Owner fails to appropriate or allocate funds for future periodic payments under the Contract after exercising reasonable efforts to do so, the Owner may upon thirty (30) days' notice, order Work on the Project to cease. The Owner will remain obligated to pay for the Work already performed but shall not be obligated to pay the balance remaining unpaid beyond the fiscal period for which funds have been appropriated or allocated and for which the Work has not been done.

**TIME OF COMPLETION AND LIQUIDATED DAMAGES:**

The Contract Time shall be **Ninety (90)** calendar days. See Article III of the Agreement.

Liquidated damages for delay in Completion of the Work within the Contract Time, or for delay in completion of a specified portion of the Work by a milestone deadline, will accrue and may be assessed as provided in the Contract Documents, including Article III of the Agreement and Article 8 of the General Conditions.

**COVID-19**

During the Work, the Contractor shall ensure that all Work, including but not limited to Work performed by Subcontractors, is performed in compliance with all applicable legal, contractual, and local government requirements related to the novel coronavirus and COVID-19, including “social distancing,” masks, and hygiene as may be ordered by the State or local authorities and as may be directed in the Contract Documents. Each bidder must include in its bid all costs related to these requirements in effect at the time of bidding. If additional COVID-19 requirements are imposed after the bid and the Contractor believes that it is entitled to additional time or money, it must timely submit proper requests pursuant to the Contract Documents.

**GENERAL CONDITIONS**  
**for**  
**CONTRACT OF CONSTRUCTION**

**FOR Bid# 15/23-24-Desert Winds, Eastside, and R. Rex Parris High Schools Re-Roofs**

**Antelope Valley Union High School District [OWNER]**

**April 18, 2024**

**SUMMARY OF CONTENTS**

ARTICLE 1: GENERAL  
CONDITIONS .....  
1 .....

ARTICLE  
2: OWNER.....  
7 .....

ARTICLE 3: THE  
CONTRACTOR .....  
10 .....

ARTICLE 4: ADMINISTRATION OF THE  
CONTRACT 27.....

ARTICLE  
5: SUBCONTRACTORS .....  
42 .....

ARTICLE 6: CONSTRUCTION BY OWNER OR BY SEPARATE  
CONTRACTORS .....  
48

ARTICLE 7: CHANGES IN THE  
WORK 50.....

ARTICLE  
8: TIME.....  
58 .....



ARTICLE 9: PAYMENTS AND  
COMPLETION.....  
63 .....

ARTICLE 10: PROTECTION OF PERSONS AND  
PROPERTY 73.....

ARTICLE 11: INSURANCE AND  
BONDS 78.....  
.....  
.....

ARTICLE 12: UNCOVERING AND CORRECTION OF  
WORK 84.....

ARTICLE 13: MISCELLANEOUS  
PROVISIONS 86.....  
.....  
.....

ARTICLE 14: TERMINATION OR SUSPENSION OF THE  
CONTRACT 98.....

## TABLE OF CONTENTS

ARTICLE 1 .....	1	2.2 INFORMATION AND SERVICES	
GENERAL CONDITIONS .....	1	REQUIRED OF THE OWNER.....	7
1.1 BASIC DEFINITIONS .....	1	2.2.1 INTENTIONALLY LEFT BLANK .....	7
1.1.1 THE CONTRACT DOCUMENTS.....	1	2.2.2 SITE SURVEY .....	7
1.1.2 THE CONTRACT.....	1	2.2.3 SOILS.....	7
1.1.3 THE WORK .....	1	2.2.3.1 <i>Owner Furnished Services</i> .....	7
1.1.4 THE PROJECT .....	2	2.2.3.2 <i>Contractor Reliance</i> .....	7
1.1.5 THE DRAWINGS.....	2	2.2.4 UTILITY SURVEY .....	8
1.1.6 THE SPECIFICATIONS.....	2	2.2.5 INFORMATION.....	8
1.1.7 THE PROJECT MANUAL .....	2	2.2.6 EXISTING UTILITY LINES; REMOVAL,	
1.1.8 OR .....	2	RELOCATION.....	8
1.1.9 COMPLETION.....	2	2.2.6.1 <i>Removal, Relocation</i> .....	8
1.1.10 COMPLETION OF THE PROJECT .....	3	2.2.6.2 <i>Assessment</i> .....	8
1.2 EXECUTION, CORRELATION AND		2.2.6.3 <i>Notification</i> .....	8
INTENT .....	3	2.2.6.4 <i>Underground Utility Clearance</i>	9
1.2.1 CORRELATION AND INTENT.....	3	2.2.7 EASEMENTS .....	9
1.2.1.1 <i>Documents Complementary and</i>		2.2.8 REASONABLE PROMPTNESS .....	9
<i>Inclusive</i> .....	3	2.2.9 COPIES FURNISHED.....	9
1.2.1.2 <i>Coverage of the Drawings and</i>		2.2.10 DUTIES CUMULATIVE.....	9
<i>Specifications</i> .....	3	2.3 OWNER'S RIGHT TO STOP THE	
1.2.1.3 <i>Conflicts</i> .....	3	WORK .....	9
1.2.1.4 <i>Conformance With Laws</i> .....	3	2.4 OWNER'S RIGHT TO CARRY OUT	
1.2.1.5 <i>Ambiguity</i> .....	4	THE WORK.....	9
1.2.1.6 <i>Execution</i> .....	4	ARTICLE 3.....	10
1.2.2 ADDENDA AND DEFERRED APPROVALS	5	THE CONTRACTOR.....	10
1.2.2.1 <i>Addenda</i> .....	5	3.1 DEFINITION .....	10
1.2.2.2 <i>Deferred Approvals</i> .....	5	3.2 SUPERVISION AND	
1.2.3 SPECIFICATION INTERPRETATION.....	5	CONSTRUCTION PROCEDURES .....	10
1.2.3.1 <i>Titles</i> .....	5	3.2.1 CONTRACTOR .....	10
1.2.3.2 <i>As Shown, Etc.</i> .....	5	3.2.2 CONTRACTOR RESPONSIBILITY .....	11
1.2.3.3 <i>Provide</i> .....	5	3.2.3 OBLIGATIONS NOT CHANGED BY	
1.2.3.4 <i>General Conditions</i> .....	5	OTHERS' ACTIONS .....	11
1.2.3.5 <i>Abbreviations</i> .....	5	3.2.4 CONTRACTOR RESPONSIBILITY FOR	
1.2.3.6 <i>Plural</i> .....	5	READINESS FOR WORK.....	11
1.2.3.7 <i>Metric</i> .....	5	3.2.5 PROJECT MEETINGS.....	11
1.2.3.8 <i>Standard Specifications</i> .....	6	3.3 SUPERINTENDENT .....	11
1.2.3.9 <i>Absence of Modifiers</i> .....	6	3.3.1 FULL TIME SUPERINTENDENT.....	11
1.3 OWNERSHIP AND USE OF		3.3.2 STAFF .....	11
ARCHITECT'S DRAWINGS,		3.3.3 RIGHT TO REMOVE .....	12
SPECIFICATIONS AND OTHER		3.4 LABOR AND MATERIALS .....	12
DOCUMENTS .....	6	3.4.1 CONTRACTOR TO PROVIDE .....	12
ARTICLE 2 .....	7	3.4.2 QUALITY .....	12
OWNER .....	7	3.4.3 REPLACEMENT.....	12
2.1 DEFINITION .....	7	3.4.4 DISCIPLINE .....	12

3.5	WARRANTY.....	13	3.11.4.3	<i>Substitution Request Form</i> .....	22
3.6	TAXES.....	13	3.11.4.4	<i>List of Manufacturers and Products Required</i> .....	22
3.7	PERMITS, FEES AND NOTICES.....	13	3.11.5	DEFERRED APPROVALS.....	22
3.7.1	PAYMENT.....	13	3.12	CUTTING AND PATCHING .....	23
3.7.2	COMPLIANCE.....	13	3.12.1	SCOPE .....	23
3.7.3	CONTRACT DOCUMENTS .....	13	3.12.2	CONSENT.....	23
3.7.4	RESPONSIBILITY .....	14	3.12.3	STRUCTURAL MEMBERS .....	23
3.8	ALLOWANCES .....	14	3.12.4	Subsequent Removal.....	23
3.8.1	CONTRACT .....	14	3.13	CLEANING UP.....	23
3.8.2	SCOPE .....	14	3.13.1	CONTRACTOR’S RESPONSIBILITY .....	23
3.8.2.1	<i>Prompt Selection</i> .....	14	3.13.2	FAILURE TO CLEANUP.....	24
3.8.2.2	<i>Cost</i> .....	14	3.13.3	CONSTRUCTION BUILDINGS .....	24
3.8.2.3	<i>Cost Included in Contract Sum</i> ..	14	3.14	ACCESS TO WORK.....	24
3.8.2.4	<i>Contract Sum Adjustment</i> .....	14	3.15	ROYALTIES AND PATENTS .....	24
3.9	CONTRACTOR’S CONSTRUCTION SCHEDULES .....	14	3.15.1	PAYMENT AND INDEMNITY .....	24
3.9.1	Requirements.....	14	3.15.2	REVIEW.....	24
3.9.2	DSA OVERSIGHT PROCESS.....	17	3.16	INDEMNIFICATION .....	24
3.9.3	FAILURE TO MEET REQUIREMENTS.....	17	3.16.1	SCOPE: CONTRACTOR .....	25
3.10	DOCUMENTS AND SAMPLES AT THE SITE .....	17	3.16.2	SCOPE: SUBCONTRACTORS.....	25
3.11	SHOP DRAWINGS, PRODUCT DATA, AND SAMPLES.....	18	3.16.2.1	<i>Indemnity</i> .....	25
3.11.1	SUBMITTALS DEFINED .....	18	3.16.2.2	<i>Joint and Several Liability</i> .....	26
3.11.1.1	<i>Shop Drawings</i> .....	18	3.16.3	NO LIMITATION.....	26
3.11.1.2	<i>Samples</i> .....	18	3.17	OWNER AS INTENDED BENEFICIARY .....	26
3.11.1.3	<i>Contractor’s Responsibility</i> .....	18	3.18	NOTICE OF EXCUSE FOR NONPERFORMANCE .....	26
3.11.1.4	<i>Extent of Review</i> .....	19	3.19	RECOVERY OF DAMAGES FROM OWNER	
3.11.2	DRAWING SUBMISSION PROCEDURE...19		ARTICLE 4.....		30
3.11.2.1	<i>Transmittal Letter and Other Requirements</i> .....	19	ADMINISTRATION OF THE CONTRACT		30
3.11.2.2	<i>Copies Required</i> .....	19	4.1	ARCHITECT.....	30
3.11.2.3	<i>Corrections</i> .....	20	4.1.1	DEFINITION.....	30
3.11.2.4	<i>Approval Prior to Commencement of Work</i> .....	20	4.1.2	MODIFICATION .....	30
3.11.3	SAMPLE SUBMISSIONS PROCEDURE ....20		4.1.3	TERMINATION.....	30
3.11.3.1	<i>Samples Required</i> .....	20	4.2	ARCHITECT’S ADMINISTRATION OF THE CONTRACT.....	30
3.11.3.2	<i>Labels and Instructions</i> .....	20	4.2.1	STATUS.....	30
3.11.3.3	<i>Architect’s Review</i> .....	20	4.2.2	SITE VISITS.....	30
3.11.3.4	<i>Record Drawings and Annotated Specifications</i> .....	21	4.2.3	LIMITATIONS OF CONSTRUCTION RESPONSIBILITY .....	31
3.11.3.5	<i>Equipment Manuals</i> .....	21	4.2.4	COMMUNICATIONS FACILITATING CONTRACT ADMINISTRATION .....	31
3.11.3.6	<i>Owner’s Property</i> .....	21	4.2.5	PAYMENT APPLICATIONS .....	31
3.11.4	SUBSTITUTIONS .....	21	4.2.6	REJECTION OF WORK.....	31
3.11.4.1	<i>One Product Specified</i> .....	21	4.2.7	CHANGE ORDERS .....	31
3.11.4.2	<i>Two or More Products Specified</i> .....	22			

4.2.8	WARRANTIES UPON COMPLETION .....	31
4.2.9	INTERPRETATION.....	32
4.2.10	ADDITIONAL INSTRUCTIONS .....	32
4.2.10.1	<i>Architect’s Interpretations and Decisions</i> .....	32
4.2.10.2	<i>Typical Parts and Sections</i> .....	32
4.2.10.3	<i>Dimensions</i> .....	32
4.3	INSPECTOR OF RECORD.....	32
4.3.1	GENERAL .....	32
4.3.2	INSPECTOR OF RECORD’S DUTIES .....	33
4.3.3	INSPECTOR OF RECORD’S AUTHORITY TO REJECT OR STOP WORK .....	33
4.3.4	INSPECTOR OF RECORD’S FACILITIES .....	33
4.4	RESPONSIBILITY FOR ADDITIONAL CHARGES INCURRED BY THE OWNER FOR PROFESSIONAL SERVICES.....	33
4.5	NOTICES OF POTENTIAL CHANGE, CHANGE ORDER REQUESTS, AND CLAIMS .....	34
4.5.1	NOTICE OF POTENTIAL CHANGE .....	35
4.5.2	CHANGE ORDERS REQUESTS.....	35
4.5.3	DEFINITION OF CLAIM.....	37
4.5.4	TIME FOR SUBMITTING CLAIM; WAIVER .....	37
4.5.5	CONTENT OF CLAIM .....	38
4.5.5.1	<i>Claim Format; Waiver</i> .....	38
4.5.5.2	<i>Claims for Additional Money</i> .....	40
4.5.5.3	<i>Claims for Additional Time</i>	
4.5.5.3.1	<i>Notice of Extent of Claim</i>	
4.5.5.3.2	<i>Unusually Severe Weather Claims</i>	
4.5.5.4	<i>Pass Through Claims</i> .....	41
4.5.6	PROCEDURES FOR CLAIMS (PUBLIC CONTRACT CODE SECTION 9204) .....	42
4.5.6.1	<i>Claims</i> .....	42
4.5.6.2	<i>Meet and Confer</i> .....	42
4.5.6.4	<i>Government Code Claim</i> .....	43
4.5.8	CONTINUING CONTRACT PERFORMANCE .....	44
4.5.9	CLAIMS FOR CONCEALED OR UNKNOWN CONDITIONS .....	44
4.5.81	<i>Trenches or Excavations Less Than Four Feet Below the Surface</i> .....	44

4.5.8.2	<i>Trenches or Excavations Greater Than Four Feet Below the Surface</i> .....	44
4.5.9	INJURY OR DAMAGE TO PERSON OR PROPERTY .....	45
ARTICLE 5	.....	45
SUBCONTRACTORS	.....	45
5.1	DEFINITIONS .....	45
5.1.1	SUBCONTRACTOR .....	45
5.1.2	SUB-SUBCONTRACTOR .....	46
5.1.3	SPECIALTY CONTRACTORS .....	46
5.2	AWARD OF SUBCONTRACTS AND OTHER CONTRACTS FOR PORTIONS OF THE WORK.....	46
5.2.1	ASSIGNMENT OR SUBSTITUTION - CONSENT OF OWNER.....	46
5.2.2	GROUND FOR SUBSTITUTION .....	46
5.2.2.1	<i>No Change in Contract</i> .....	47
5.2.2.2	<i>Substitution Due to Clerical Error</i> .....	47
5.3	SUBCONTRACTUAL RELATIONS.	48
5.4	CONTINGENT ASSIGNMENT OF SUBCONTRACTS .....	48
5.5	SUBCONTRACTOR’S RESPONSIBILITIES.....	49
5.5.1	SUPERVISION BY SUBCONTRACTORS ...	49
5.5.2	DISCIPLINE AND ORDER .....	49
5.5.3	DEFECTS DISCOVERED .....	49
5.5.4	SUBCONTRACTOR INFORMATION.....	49
5.5.5	TEMPORARY STRUCTURES.....	50
5.5.6	CHARGES TO SUBCONTRACTOR.....	50
5.5.7	FINES IMPOSED .....	50
5.5.8	PROJECT SIGNS .....	50
5.5.9	REMEDIES FOR FAILURE TO PERFORM ..	50
5.5.10	DISPUTES NOT TO AFFECT WORK .....	51
5.5.11	APPLICATION FOR PAYMENT .....	51
5.5.12	COMPLIANCE WITH PROCEDURES.....	51
5.5.13	ON-SITE RECORD KEEPING .....	51
5.5.14	NON-EXCLUSIVE OBLIGATIONS .....	51
ARTICLE 6	.....	52
CONSTRUCTION BY OWNER OR BY SEPARATE CONTRACTORS .....		52
6.1	OWNER’S RIGHT TO PERFORM CONSTRUCTION AND TO AWARD SEPARATE CONTRACTS.....	52
6.1.1	OWNER’S RIGHTS .....	52
6.1.2	DESIGNATION AS CONTRACTOR .....	52

6.1.3 CONTRACTOR DUTIES .....	52	8.1 DEFINITIONS .....	62
6.1.4 OWNER OBLIGATIONS .....	52	8.1.1 CONTRACT TIME .....	62
6.2 MUTUAL RESPONSIBILITY .....	53	8.1.2 NOTICE TO PROCEED .....	62
6.2.1 DELIVERY AND STORAGE .....	53	8.1.3 DAYS .....	62
6.2.2 NOTICE BY CONTRACTOR .....	53	8.2 HOURS OF WORK .....	62
6.2.3 COSTS INCURRED .....	53	8.2.1 SUFFICIENT FORCES .....	62
6.2.4 CORRECTION OF DAMAGE .....	53	8.2.2 PERFORMANCE DURING WORKING	
6.3 OWNER'S RIGHT TO CLEAN UP ....	53	HOURS .....	62
ARTICLE 7 .....	54	8.2.3 LABOR CODE APPLICATION .....	62
CHANGES IN THE WORK .....	54	8.2.4 COSTS FOR AFTER HOURS INSPECTIONS	63
7.1 CHANGES .....	54	8.2.5 TIME FOR COMMENCEMENT BY	
7.1.1 NO CHANGES WITHOUT		SUBCONTRACTORS .....	63
AUTHORIZATION .....	54	8.3 PROGRESS AND COMPLETION ....	63
7.1.2 AUTHORITY TO ORDER MINOR		8.3.1 TIME OF THE ESSENCE .....	63
CHANGES .....	54	8.3.2 NO COMMENCEMENT WITHOUT	
7.2 CHANGE ORDERS .....	55	INSURANCE .....	64
7.3 CONSTRUCTION CHANGE		8.3.3 EXPEDITIOUS COMPLETION .....	64
DIRECTIVES ("CCD") .....	55	8.4 EXTENSIONS OF TIME -	
7.3.1 DEFINITION .....	55	LIQUIDATED DAMAGES .....	64
7.3.2 USE TO DIRECT CHANGE .....	55	8.4.1 CONDITIONS ALLOWING FOR EXTENSIONS	
7.4 REQUEST FOR INFORMATION		OF TIME TO COMPLETE THE WORK ONLY	
("RFI") .....	55	(EXCUSABLE DELAY)	
7.4.1 DEFINITION .....	55	8.4.2 COMPENSABLE DELAY (TIME AND	
7.4.2 SCOPE .....	56	MONEY)	
7.4.3 RESPONSE TIME .....	56	8.4.3 NOTICE BY CONTRACTOR REQUIRED;	
7.4.4 COSTS INCURRED .....	56	PROCEDURES FOR DEMANDING ADDITIONAL	
7.5 REQUEST FOR PROPOSAL ("RFP")	56	TIME OR MONEY .....	65
7.5.1 DEFINITION .....	56	8.4.4 EARLY COMPLETION .....	65
7.5.2 SCOPE .....	57	8.4.5 LIQUIDATED DAMAGES	
7.6 CHANGE ORDER REQUEST		8.5 GOVERNMENT APPROVALS .....	66
("COR") .....	57	ARTICLE 9 .....	66
7.6.1 DEFINITION .....	57	PAYMENTS AND COMPLETION .....	66
7.6.2 CHANGES IN PRICE .....	57	9.1 CONTRACT SUM .....	66
7.6.3 CHANGES IN TIME .....	57	9.2 COST BREAKDOWN .....	66
7.7 PRICE OF CHANGE ORDERS .....	57	9.2.1 REQUIRED INFORMATION .....	66
7.7.1 SCOPE .....	57	9.2.2 OWNER ACCEPTANCE REQUIRED .....	67
7.7.2 DETERMINATION OF COST .....	57	9.3 APPLICATIONS FOR PAYMENT ....	67
7.7.3 FORMAT FOR PROPOSED COST CHANGE	60	9.3.1 PROCEDURE .....	67
7.7.4 DISCOUNTS, REBATES, AND REFUNDS ..	61	9.3.2 PURCHASE OF MATERIALS AND	
7.7.5 ACCOUNTING RECORDS .....	61	EQUIPMENT .....	68
7.7.6 NOTICE REQUIRED .....	61	9.3.3 WARRANTY OF TITLE .....	68
7.7.7 APPLICABILITY TO SUBCONTRACTORS ..	61	9.4 REVIEW OF PROGRESS PAYMENT .	69
7.8 WAIVER OF RIGHT TO CLAIM MONEY		9.4.1 OWNER ACCEPTANCE .....	69
OR TIME .....	61		
ARTICLE 8 .....	62		
TIME .....	62		

9.4.2 OWNER’S REVIEW.....	69	10.2.4 USE OR STORAGE OF HAZARDOUS MATERIAL.....	78
9.5 DECISIONS TO WITHHOLD PAYMENT .....	69	10.2.5 FINGERPRINTING .....	79
9.5.1 REASONS TO WITHHOLD PAYMENT.....	69	10.3 PROTECTION OF WORK AND PROPERTY .....	79
9.5.2 PAYMENT AFTER CURE.....	72	10.3.1 PROTECTION OF WORK	
9.5.3 OVERPAYMENT AND/OR FAILURE TO WITHHOLD .....	72	10.3.2 PROTECTION FOR ELEMENTS.....	79
9.6 PROGRESS PAYMENTS .....	72	10.3.3 SHORING AND STRUCTURAL LOADING	79
9.6.1 PAYMENTS TO CONTRACTOR .....	72	10.3.4 CONFORMANCE WITHIN ESTABLISHED LIMITS .....	80
9.6.2 PAYMENTS TO SUBCONTRACTORS.....	72	10.3.5 SUBCONTRACTOR ENFORCEMENT OF RULES .....	80
9.6.3 PERCENTAGE OF COMPLETION OR PAYMENT INFORMATION .....	73	10.3.6 SITE ACCESS .....	80
9.6.4 NO OBLIGATION OF OWNER FOR SUBCONTRACTOR PAYMENT.....	73	10.3.7 PROTECTION OF MATERIALS .....	80
9.6.5 PAYMENT TO SUPPLIERS .....	73	10.4 EMERGENCIES .....	80
9.6.6 PAYMENT NOT CONSTITUTING APPROVAL OR ACCEPTANCE.....	73	10.4.1 EMERGENCY ACTION .....	80
9.6.7 JOINT CHECKS.....	73	10.4.2 ACCIDENT REPORTS.....	80
9.7 COMPLETION OF THE WORK .....	73	10.5 HAZARDOUS MATERIALS.....	81
9.7.1 CLOSE-OUT PROCEDURES .....	73	10.5.1 DISCOVERY OF HAZARDOUS MATERIALS.....	81
9.7.2 COSTS OF MULTIPLE INSPECTIONS .....	74	10.5.2 HAZARDOUS MATERIAL WORK LIMITATIONS.....	81
9.8 PARTIAL OCCUPANCY OR USE.....	74	10.5.3 INDEMNIFICATION BY OWNER FOR HAZARDOUS MATERIAL NOT CAUSED BY CONTRACTOR.....	81
9.9 FINAL PROGRESS PAYMENT AND RELEASE OF RETENTION.....	75	10.5.4 NATURALLY OCCURRING ASBESTOS .	81
9.9.1 FINAL APPLICATION FOR PROGRESS PAYMENT .....	75	10.5.5 INDEMNIFICATION BY CONTRACTOR FOR HAZARDOUS MATERIAL CAUSED BY CONTRACTOR.....	82
9.9.2 PROCEDURES FOR APPLICATION FOR FINAL PROGRESS PAYMENT .....	75	10.5.6 TERMS OF HAZARDOUS MATERIAL PROVISION .....	82
9.9.3 RELEASE OF RETAINAGE .....	76	10.5.7 ARCHEOLOGICAL MATERIALS.....	82
9.10 SUBSTITUTION OF SECURITIES....	76	ARTICLE 11 .....	82
ARTICLE 10 .....	77	INSURANCE AND BONDS.....	82
PROTECTION OF PERSONS AND PROPERTY.....	77	11.1 CONTRACTOR’S LIABILITY INSURANCE.....	82
10.1 SAFETY PRECAUTIONS AND PROGRAMS .....	77	11.1.1 LIABILITY INSURANCE REQUIREMENTS.....	82
10.1.1 CONTRACTOR RESPONSIBILITY.....	77	11.1.2 SUBCONTRACTOR INSURANCE REQUIREMENTS.....	84
10.1.2 SUBCONTRACTOR RESPONSIBILITY....	77	11.1.3 OWNER’S INSURANCE .....	84
10.1.3 COOPERATION .....	77	11.1.4 ADDITIONAL INSURED ENDORSEMENT REQUIREMENTS.....	84
10.1.4 ACCIDENT REPORTS .....	77	11.1.5 WORKERS’ COMPENSATION INSURANCE .....	84
10.1.5 FIRST-AID SUPPLIES AT SITE .....	78		
10.2 SAFETY OF PERSONS AND PROPERTY.....	78		
10.2.1 THE CONTRACTOR.....	78		
10.2.2 CONTRACTOR NOTICES.....	78		
10.2.3 SAFETY BARRIERS AND SAFEGUARDS	78		

11.1.6 BUILDER’S RISK/"ALL RISK" INSURANCE		13.5 TESTS AND INSPECTIONS.....	91
11.1.6.1 COURSE-OF-CONSTRUCTION INSURANCE REQUIREMENTS		13.5.1 COMPLIANCE.....	91
11.1.7 CONSENT OF INSURER FOR PARTIAL  OCCUPANCY OR USE.....	86	13.5.2 INDEPENDENT TESTING LABORATORY	91
11.1.8 FIRE INSURANCE.....	86	13.5.3 ADVANCE NOTICE TO INSPECTOR OF RECORD .....	91
11.1.9 OTHER INSURANCE.....	86	13.5.4 TESTING OFF-SITE .....	91
11.1.10 PROOF OF CARRIAGE OF INSURANCE.....	86	13.5.5 ADDITIONAL TESTING OR INSPECTION	92
11.1.11 COMPLIANCE .....	87	13.5.6 COSTS FOR RETESTING.....	92
11.2 PERFORMANCE AND PAYMENT BONDS .....	87	13.5.7 COSTS FOR PREMATURE TEST .....	92
11.2.1 BOND REQUIREMENTS .....	87	13.5.8 TESTS OR INSPECTIONS NOT TO DELAY WORK .....	92
11.2.2 SURETY QUALIFICATION.....	87	13.6 [INTENTIONALLY LEFT BLANK] .	92
ARTICLE 12 .....	88	13.7 TRENCH EXCAVATION .....	92
UNCOVERING AND CORRECTION OF WORK .....	88	13.7.1 TRENCHES GREATER THAN FIVE FEET.	92
12.1 UNCOVERING OF WORK .....	88	13.7.2 EXCAVATION SAFETY .....	92
12.1.1 UNCOVERING WORK FOR REQUIRED INSPECTIONS.....	88	13.7.3 NO TORT LIABILITY OF OWNER .....	93
12.1.2 COSTS FOR INSPECTIONS NOT REQUIRED.....	88	13.7.4 NO EXCAVATION WITHOUT PERMITS.	93
12.2 CORRECTION OF WORK; WARRANTY .....	88	13.8 WAGE RATES.....	93
12.2.1 CORRECTION OF REJECTED WORK.....	88	13.8.1 WAGE RATES .....	93
12.2.2 REMOVAL OF NONCONFORMING WORK .....	88	13.8.2 HOLIDAY AND OVERTIME PAY.....	93
12.2.3 OWNER’S RIGHTS IF CONTRACTOR FAILS TO CORRECT .....	89	13.8.3 WAGE RATES NOT AFFECTED BY SUBCONTRACTS .....	93
12.2.4 COST OF CORRECTING THE WORK .....	89	13.8.4 CHANGE IN PREVAILING WAGE DURING BID OR CONSTRUCTION.....	93
12.2.5 WARRANTY CORRECTIONS.....	89	13.8.5 FORFEITURE AND PAYMENTS .....	94
12.2.6 NO TIME LIMITATION .....	89	13.8.6 MINIMUM WAGE RATES .....	94
12.3 NONCONFORMING WORK AND WITHHOLDING THE VALUE OF IT .....	90	13.8.7 PER DIEM WAGES .....	94
ARTICLE 13 .....	90	13.8.8 POSTING OF WAGE RATES AND OTHER REQUIRED JOB SITE NOTICES.....	94
MISCELLANEOUS PROVISIONS.....	90	13.9 RECORD OF WAGES PAID: INSPECTION .....	95
13.1 GOVERNING LAW .....	90	13.9.1 APPLICATION OF LABOR CODE.....	95
13.2 SUCCESSORS AND ASSIGNS.....	90	13.10 APPRENTICES.....	97
13.3 WRITTEN NOTICE .....	90	13.10.1 APPRENTICE WAGES AND DEFINITIONS .....	97
13.4 RIGHTS AND REMEDIES .....	90	13.10.2 APPRENTICE LABOR POOL.....	97
13.4.1 DUTIES AND OBLIGATIONS CUMULATIVE.....	90	13.10.3 JOURNEYMAN/APPRENTICE RATIO; COMPUTATION OF HOURS .....	98
13.4.2 NO WAIVER.....	91	13.10.4 JOURNEYMAN/APPRENTICE RATIO	98
		13.10.4.1 <i>Apprenticeable Craft or Trade</i> ..	98
		13.10.5 RATIO EXEMPTION .....	99
		13.10.6 APPRENTICE FUND .....	99
		13.10.7 PRIME CONTRACTOR COMPLIANCE	99
		13.10.8 DECISIONS OF JOINT APPRENTICESHIP COMMITTEE .....	99
		13.10.9 NO BIAS .....	100

13.10.10 VIOLATION OF LABOR CODE.....	100	14.2.2 NOTIFICATION OF TERMINATION.....	103
13.11 ASSIGNMENT OF ANTITRUST		14.2.3 PAYMENTS WITHHELD	
CLAIMS .....	101	14.2.4 PAYMENTS UPON COMPLETION	
13.11.1 APPLICATION .....	101	14.2.5 INCLUSION OF TERMINATION FOR	
13.11.2 ASSIGNMENT OF CLAIM .....	101		
13.12 AUDIT .....	101	CONVENIENCE.....	103
13.13 STORM WATER DISCHARGE		14.3 SUSPENSION OR TERMINATION BY	
PERMIT .....	101	THE OWNER FOR CONVENIENCE.....	104
ARTICLE 14 .....	102	14.3.1 SUSPENSION BY OWNER.....	104
TERMINATION OR SUSPENSION OF THE		14.3.1.1 <i>Adjustments</i> .....	104
CONTRACT.....	102	14.3.1.2 <i>Adjustments for Fixed Cost</i> .....	104
14.1 TERMINATION BY THE		14.3.2 TERMINATION BY THE OWNER FOR	
CONTRACTOR FOR CAUSE		CONVENIENCE.....	104
		14.4 NOT A WAIVER .....	104
14.2 TERMINATION BY THE OWNER FOR		14.5 MUTUAL TERMINATION FOR	
CAUSE		CONVENIENCE .....	105
14.2.1 GROUNDS FOR TERMINATION		14.6 EARLY TERMINATION .....	105



## **ARTICLE 1**

### **GENERAL CONDITIONS**

#### **1.1 BASIC DEFINITIONS**

##### **1.1.1 THE CONTRACT DOCUMENTS**

The "Contract Documents" consist of the Agreement between Owner and Contractor (hereinafter the Agreement), Conditions of the Contract (General, Supplementary and other Conditions), Drawings, Specifications, addenda issued prior to bid, Instructions to Bidders, Notice to Bidders, the Bid Form, Payment Bond, Performance Bond, required insurance certificates, additional insured endorsement and declarations page, Designation of Subcontractors, Noncollusion Declaration, Roof Project Certification (where applicable), Sufficient Funds Declaration (Labor Code section 2810) and the Fingerprinting Notice and Acknowledgment and Independent Contractor Student Contact Form, other documents referred to in the Agreement, and Modifications issued after execution of the Agreement. A Modification is a written amendment to the Contract signed by both parties, a Change Order, a Construction Change Directive, or a written order for a minor change in the Work issued by the Owner. The Contract Documents are complementary, and each obligation of the Contractor, Subcontractors, material or equipment suppliers in any one shall be binding as if specified in all.

##### **1.1.2 THE CONTRACT**

The Contract Documents form the Contract. The "Contract" represents the entire and integrated agreement between the parties hereto and supersedes prior negotiations, representations, or agreements, either written or oral. The Contract may be amended or modified only by a written Modification. The Contract Documents shall not be construed to create a contractual relationship of any kind between the Architect and Contractor, any Construction Manager and Contractor, between the Owner and any Subcontractor or Sub-subcontractor, or between any persons or entities other than the Owner and the Contractor. The terms of the Contract shall not be waived, altered, modified, supplemented or amended in any manner whatsoever except by written agreement signed by the parties and approved or ratified by the Governing Board.

##### **1.1.3 THE WORK**

The "Work" shall include all labor, materials, services and equipment necessary for the Contractor to fulfill all of its obligations pursuant to the Contract Documents, including but not limited to punch list items and submission of documents. It shall include the initial obligation of any Contractor or Subcontractor, who performs any portion of the Work, to visit the Site of the proposed Work with Owner's representatives, a continuing obligation after the commencement of the Work to fully acquaint and familiarize itself with the conditions as they exist and the character of the operations to be carried on under the Contract Documents, and make such investigation as it may see fit so that it shall fully understand the facilities, physical conditions, and restrictions attending the Work under the Contract Documents. Each such Contractor or Subcontractor shall also thoroughly examine and become familiar with the Drawings,

Specifications, and associated bid documents. The “Site” refers to the grounds of the Project as defined in the Contract Documents and such adjacent lands as may be directly affected by the performance of the Work. The Work shall constitute a “work of improvement” under Civil Code section 8050 and Public Contract Code section 7107.

#### **1.1.4 THE PROJECT**

The “Project” is the total construction of the Work performed in accordance with the Contract Documents. However, where applicable, the Project may also include construction by the Owner or by separate contractors.

#### **1.1.5 THE DRAWINGS**

The “Drawings” are graphic and pictorial portions of the Contract Documents prepared for the Project and approved changes thereto, wherever located and whenever issued, showing the design, location, and scope of the Work, generally including plans, elevations, sections, details, schedules, and diagrams as drawn or approved by the Architect.

#### **1.1.6 THE SPECIFICATIONS**

The “Specifications” are that portion of the Contract Documents consisting of the written requirements for material, equipment, construction systems, instructions, quality assurance standards, workmanship, and performance of related services.

#### **1.1.7 THE PROJECT MANUAL**

The “Project Manual” is the volume usually assembled for the Work which may include, without limitation, the bidding requirements, sample forms, Agreement, Conditions of the Contract, and Specifications.

#### **1.1.8 OR**

“Or” shall include “and/or.”

#### **1.1.9 COMPLETION**

Statutory definitions of “Completion” and “Complete” shall apply for those statutory purposes. For all other purposes, including accrual of liquidated damages, Claims and warranties, “Completion” and “Complete” mean the point in the Work where (1) Contractor has fully and correctly performed all Work in all parts and requirements, including corrective and punch list work, and (2) Owner’s representatives have conducted a final inspection that confirmed this performance. Substantial, or any other form of partial or non-compliant, performance shall not constitute “Completion” or “Complete” under the Contract Documents, except to the extent that substantial completion is required for a milestone deadline.

### 1.1.10 COMPLETION OF THE PROJECT

For purposes of accrual of liquidated damages for delays to the Project, *completion* shall mean the point in the Project where (1) all contractors and Owner have fully and correctly performed all work of the entire Project in all parts and requirements, including corrective and punch list work, and (2) Owner's representatives have conducted a final inspection of the entire Project that confirmed this performance. Substantial, or any other form of partial or non-compliant, performance of the entire Project shall not constitute *completion* or *complete*.

## 1.2 EXECUTION, CORRELATION AND INTENT

### 1.2.1 CORRELATION AND INTENT

1.2.1.1 ***Documents Complementary and Inclusive.*** The Contract Documents are complementary and are intended to include all items required for the proper execution and Completion of the Work. Any item of work mentioned in the Specifications and not shown on the Drawings, or shown on the Drawings and not mentioned in the Specifications, shall be provided by Contractor as if shown or mentioned in both.

1.2.1.2 ***Coverage of the Drawings and Specifications.*** The Drawings and Specifications generally describe the work to be performed by Contractor. Generally, the Specifications describe work which cannot be readily indicated on the Drawings and indicate types, qualities, and methods of installation of the various materials and equipment required for the Work. It is not intended to mention every item of Work in the Specifications, which can be adequately shown on the Drawings, or to show on the Drawings all items of Work described or required by the Specifications even if they are of such nature that they could have been shown. All materials or labor for Work, which is shown on the Drawings or the Specifications (or is reasonably inferable therefrom as being necessary to Complete the Work), shall be provided by the Contractor whether or not the Work is expressly covered in the Drawings or the Specifications. It is intended that the Work be of sound, quality construction, and the Contractor shall be responsible for the inclusion of adequate amounts to cover installation of all items indicated, described, or implied in the portion of the Work to be performed by Contractor.

1.2.1.3 ***Conflicts.*** Without limiting Contractor's obligation to identify conflicts for resolution by the Owner, it is intended that the more stringent, higher quality, and greater quantity of Work shall apply.

1.2.1.4 ***Conformance With Laws.*** Each and every provision of law required by law to be inserted in this Contract shall be deemed to be inserted herein, and the Contract shall be read and enforced as though it were included herein, and if through mistake or otherwise any such provision is not inserted, or is not correctly inserted, then upon application of either party the Contract shall be amended in writing to make such insertion or correction.

Before commencing any portion of the Work, Contractor shall check and review the Drawings and Specifications for such portion for conformance and compliance with all laws, ordinances, codes, rules and regulations of all governmental authorities and public utilities

affecting the construction and operation of the physical plant of the Project, all quasi-governmental and other regulations affecting the construction and operation of the physical plant of the Project, and other special requirements, if any, designated in the Contract Documents. In the event Contractor observes any violation of any law, ordinance, code, rule or regulation, or inconsistency with any such restrictions or special requirements of the Contract Documents, Contractor shall promptly notify Architect and Owner in writing of same and shall ensure that any such violation or inconsistency shall be corrected in the manner provided hereunder prior to the construction of that portion of the Work. Where requirements of the Contract Documents exceed those of the applicable building codes and ordinances, the Contract Documents shall govern. Contractor shall comply with all applicable Federal, State and local laws.

If, as and to the extent that Public Contract Code section 1104 is deemed to apply after the award of the Contract, Contractor shall not be required to assume responsibility for the completeness and accuracy of architectural or engineering plans and specifications, notwithstanding any other provision in the Contract Documents, except to the extent that Contractor discovered or should have discovered and reported any errors and omissions to the Architect and Owner, including but not limited to as the result of any review of the plans and specifications by Contractor required by the Instructions to Bidders or other Contract Documents, whether or not actually performed by Contractor.

1.2.1.5 **Ambiguity.** Before commencing any portion of the Work, Contractor shall carefully examine all Drawings and Specifications and other information given to Contractor as to materials and methods of construction and other Project requirements. Contractor shall immediately notify Architect and Owner in writing of any perceived or alleged error, inconsistency, ambiguity, or lack of detail or explanation in the Drawings and Specifications in the manner provided herein. If the Contractor or its Subcontractors, material or equipment suppliers, or any of their officers, agents, and employees performs, permits, or causes the performance of any Work under the Contract Documents, which it knows or should have known to be in error, inconsistent, or ambiguous, or not sufficiently detailed or explained, Contractor shall bear any and all costs arising therefrom including, without limitation, the cost of correction thereof without increase or adjustment to the Contract Sum or the time for performance. If Contractor performs, permits, or causes the performance of any Work under the Contract Documents prepared by or on behalf of Contractor which is in error, inconsistent or ambiguous, or not sufficiently detailed or explained, Contractor shall bear any and all resulting costs, including, without limitation, the cost of correction, without increase to or adjustment in the Contract Sum or the time for performance. In no case shall any Subcontractor proceed with the Work if uncertain without the Contractor's written direction and/or approval.

1.2.1.6 **Execution.** Execution of the Agreement Between Owner and Contractor by the Contractor is a representation that the Contractor has visited the Site, become familiar with the local conditions under which the Work is to be performed and has correlated personal observations with the requirements of the Contract Documents.

## 1.2.2 ADDENDA AND DEFERRED APPROVALS

1.2.2.1 **Addenda.** Subsequent addenda issued shall govern over prior addenda only to the extent specified. In accordance with Title 24, California Code of Regulations, addenda shall be approved by the Division of the State Architect (“DSA”).

1.2.2.2 **Deferred Approvals.** The requirements approved by the DSA on any item submitted as a deferred approval in accordance with Title 24, California Code of Regulations, shall take precedence over any previously issued addenda, drawing or specification.

## 1.2.3 SPECIFICATION INTERPRETATION

1.2.3.1 **Titles.** The Specifications are separated into titled sections for convenience only and not to dictate or determine the trade or craft involved. Organization of the Specifications into divisions, sections and articles, and arrangement of Drawings shall not control the Contractor in dividing the Work among Subcontractors or in establishing the extent of work to be performed by any trade.

1.2.3.2 **As Shown, Etc.** Where “as shown,” “as indicated,” “as detailed,” or words of similar import are used, reference is made to the Drawings accompanying the Specifications unless otherwise stated. Where “as directed,” “as required,” “as permitted,” “as authorized,” “as accepted,” “as selected,” or words of similar import are used, the direction, requirement, permission, authorization, approval, acceptance, or selection by Architect is intended unless otherwise stated.

1.2.3.3 **Provide.** “Provide” means “provided complete in place,” that is, furnished, installed, tested, and ready for operation and use.

1.2.3.4 **General Conditions.** The General Conditions and any supplementary general conditions are a part of each and every section of the Specifications.

1.2.3.5 **Abbreviations.** In the interest of brevity, the Specifications are written in an abbreviated form and may not include complete sentences. Omission of words or phrases such as “Contractor shall,” “shall be,” etc., are intentional. Nevertheless, the requirements of the Specifications are mandatory. Omitted words or phrases shall be supplied by inference in the same manner as they are when a “note” occurs on the Drawings.

1.2.3.6 **Plural.** Words in the singular shall include the plural whenever applicable or the context so indicates.

1.2.3.7 **Metric.** The Specifications may indicate metric units of measurement as a supplement to U.S. customary units. When indicated thus: 1” (25 mm), the U. S. customary unit is specific, and the metric unit is nonspecific. When not shown with parentheses, the unit is specific. The metric units correspond to the “International System of Units” (SI) and generally follow ASTM E 380, “Standard for Metric Practice.”

1.2.3.8 **Standard Specifications.** Any reference to standard specifications of any society, institute, association, or governmental authority is a reference to the organization's standard specifications, which are in effect as of the date the Notice to Bidders is first published. If applicable specifications are revised prior to completion of any part of the Work, the Contractor may, if acceptable to Owner and Architect, perform such Work in accordance with the revised specifications. The standard specifications, except as modified in the Specifications for the Project, shall have full force and effect as though printed in the Specifications. Architect will furnish, upon request, information as to how copies of the standard specifications referred to may be obtained.

1.2.3.9 **Absence of Modifiers.** In the interest of brevity, the Contract Documents frequently omit modifying words such as "all" and "any" and articles such as "the" and "an," but the fact that a modifier or an article is absent from one statement and appears in another is not intended to affect the interpretation of either statement.

### 1.3 **OWNERSHIP AND USE OF ARCHITECT'S DRAWINGS, SPECIFICATIONS AND OTHER DOCUMENTS**

The Drawings, Specifications, and other documents prepared on behalf of the Owner are instruments of the services of the Architect and its consultants and are the property of the Owner. The Contractor may retain one contract record set. Neither the Contractor nor any Subcontractor, Sub-subcontractor, or material or equipment supplier shall own or claim a copyright in the Drawings, Specifications, and other documents prepared by the Architect, and unless otherwise indicated the Architect shall be deemed the author of them. All copies of them, except the Contractor's record set, shall be returned or suitably accounted for to the Owner, upon request upon Completion of the Work. The Drawings, Specifications, and other documents prepared by the Architect, and copies thereof furnished to the Contractor, are for use solely with respect to this Contract. They are not to be used by the Contractor or any Subcontractor, Sub-subcontractor, or material or equipment supplier on other contracts or projects or for additions to this Contract or Project outside the scope of the Work without the specific written consent of the Owner and the Architect. The Contractor, Subcontractors, Sub-subcontractors, and material or equipment suppliers are granted a limited license to use and reproduce applicable portions of the Drawings, Specifications, and other documents prepared by the Architect appropriate to and for use in the execution of their Work under the Contract Documents. Submittal or distribution to meet official regulatory requirements or for other purposes in connection with this Project is not to be construed as publication in derogation of the Owner's property interest or other reserved right. All copies made under this license shall bear appropriate attribution and the statutory copyright notice, if any, shown on the Drawings, Specifications and other documents prepared by the Architect.

## ARTICLE 2

### OWNER

#### 2.1 DEFINITION

The term “Owner” means the person or entity identified as such in the Agreement and is referred to throughout the Contract Documents as if singular in number. The term “Owner” means the Owner and/or the Owner’s authorized representatives, including but not limited to architects and construction managers. To the extent the Contract Documents indicate that Owner has assigned duties to particular representatives of the Owner (such as the Architect, or any construction manager), Owner reserves the right at all times to reassign such duties to different Owner representatives.

#### 2.2 INFORMATION AND SERVICES REQUIRED OF THE OWNER

##### 2.2.1 INTENTIONALLY LEFT BLANK

##### 2.2.2 SITE SURVEY

When required by the scope of the Project, the Owner will furnish, at its expense, a legal description or a land survey of the Site, giving, as applicable, grades and lines of streets, alleys, pavements, adjoining property, rights-of-way, restrictions, easements, encroachments, zoning, deed restrictions, boundaries, and contours of the Site. Surveys to determine locations of construction, grading, and Site work shall be provided by the Contractor.

##### 2.2.3 SOILS

**2.2.3.1 *Owner Furnished Services.*** When required by the scope of the Project, the Owner will furnish, at its expense, the services of geotechnical engineers or consultants when reasonably required or as required by local or state codes. Such services with reports and appropriate professional recommendations shall include test boring, test pits, soil bearing values, percolation tests, air and water pollution tests, and ground corrosion and resistivity tests, including necessary operations for determining subsoil, air, and water conditions.

**2.2.3.2 *Contractor Reliance.*** Test borings and soils reports for the Project have been made for the Owner to indicate the subsurface materials that might be encountered at particular locations on the Project. The Owner has made these documents available to the Contractor and the Contractor has studied the results of such test borings and information that it has as to the subsurface conditions and Site geology as set forth in the test borings and soils reports. The Owner does not assume any responsibility whatsoever with respect to the sufficiency or accuracy of the borings made, or of the logs of the test borings, or of other investigations, or of the soils reports furnished pursuant hereto, or of the interpretations to be made beyond the location or depth of the borings. There is no warranty or guarantee, either express or implied that the conditions indicated by such investigations, borings, logs, soil reports or other information are representative of those existing throughout the Site of the Project, or any part thereof, or that

unforeseen developments may not occur. At the Owner's request, the Contractor shall make available to the Owner the results of any Site investigation, test borings, analyses, studies or other tests conducted by or in the possession of the Contractor or any of its agents. Nothing herein contained shall be deemed a waiver by the Contractor to pursue any available legal right or remedy it may have at any time against any third party who may have prepared any report and/or test relied upon by the Contractor.

#### 2.2.4 UTILITY SURVEY

When required by the scope of the Project, the Owner will furnish, at its expense, all information regarding known existing utilities on or adjacent to the Site, including location, size, inverts, and depths.

#### 2.2.5 INFORMATION

Upon the request of the Contractor, Owner will make available such existing information regarding utility services and Site features, including existing construction, related to the Project as is available from Owner's records. The Contractor may not rely upon the accuracy of any such information, other than that provided under Sections 2.2.2 and 2.2.4 (except that the Contractor may not rely upon and must question in writing to the Owner and the Architect any information which appears incorrect based upon Contractor's Site inspection, knowledge of the Work and Project, and prior experience with similar projects), unless specifically stated in writing that the Contractor may rely upon the designated information.

#### 2.2.6 EXISTING UTILITY LINES; REMOVAL, RELOCATION

**2.2.6.1 *Removal, Relocation.*** Pursuant to Government Code section 4215, the Owner assumes the responsibility for removal, relocation, and protection of utilities located on the Site at the time of commencement of construction under this Contract with respect to any such utility facilities which are not identified in the drawings and specifications made part of the invitation to bid. The Contractor shall not be assessed for liquidated damages for delay in Completion of the Work caused by failure of the Owner to provide for removal or relocation of such utility facilities. Owner shall compensate the Contractor for the costs of locating, repairing damage not due to the failure of the Contractor to exercise reasonable care, removing or relocating such utility facilities, and for equipment necessarily idle during such work.

**2.2.6.2 *Assessment.*** These subparagraphs shall not be construed to preclude assessment against the Contractor for any other delays in Completion of the Work. Nothing in these subparagraphs shall be deemed to require the Owner to indicate the presence of existing service laterals or appurtenances whenever the presence of such utilities on the Site can be inferred from the presence of other visible facilities, such as buildings, or meter junction boxes on or adjacent to the Site.

**2.2.6.3 *Notification.*** If the Contractor, while performing work under this Contract, discovers utility facilities not identified by the Owner in the Contract plans or specifications, Contractor shall immediately notify the Owner and the utility in writing.



**2.2.6.4 *Underground Utility Clearance.*** It shall be Contractor's sole responsibility to timely notify all public and private utilities serving the Site prior to commencing work. The Contractor shall notify and receive clearance from any cooperative agency, such as Underground Service Alert, in accordance with Government Code section 4216, et seq. Contractor shall promptly provide a copy of all such notifications to the Owner.

#### **2.2.7 EASEMENTS**

Owner shall secure and pay for easements for permanent structures or permanent changes in existing facilities, if any, unless otherwise specified in the Contract or Contract Documents.

#### **2.2.8 REASONABLE PROMPTNESS**

Information or services under Owner's control will be furnished by the Owner with reasonable promptness. The Owner shall not be liable for any delays caused by factors beyond the Owner's control including but not limited to DSA's or any other local, State or federal agency's review of bids, change order requests, RFI's or any other documents.

#### **2.2.9 COPIES FURNISHED**

The Contractor will be furnished such copies of Drawings and Project Manuals as are stated in the Contract Documents.

#### **2.2.10 DUTIES CUMULATIVE**

The foregoing are in addition to other duties and responsibilities of the Owner enumerated herein, and especially those in Article 6 (Construction by Owner or by Separate Contractors), Article 9 (Payments and Completion), and Article 11 (Insurance and Bonds).

### **2.3 OWNER'S RIGHT TO STOP THE WORK**

If the Contractor fails to correct Work which is not in accordance with the requirements of the Contract Documents, or persistently fails to carry out Work in accordance with the Contract Documents, the Owner may order the Contractor to stop the Work or any portion thereof, until the Contractor corrects the deficiencies. Contractor shall not be entitled to a time extension for any delays caused by such order. The right of the Owner to stop the Work shall not give rise to a duty on the part of the Owner to exercise this right for the benefit of the Contractor or any other person or entity, except to the extent required by Article 6.

### **2.4 OWNER'S RIGHT TO CARRY OUT THE WORK**

If the Contractor fails or refuses to carry out the Work in accordance with the Contract Documents, Owner may correct such deficiencies by whatever reasonable method the Owner may deem expedient without prejudice to other remedies the Owner may have, including but not limited to having another contractor perform some or all of the Work without terminating the

Contract with Contractor. Owner may exercise this right at any time during the Contractor's Work.

Owner shall first provide written notice to Contractor of Contractor's failure or refusal to perform. The notice will provide the time period within which Contractor must begin correction of the failure or refusal to perform. If the Contractor fails to begin correction within the stated time, or fails to continue correction, the Owner may proceed to correct the deficiencies. In the event the Owner bids the work, Contractor shall not be eligible for the award of the contract. The Contractor may be invoiced the cost to Owner of the work, including compensation for additional professional and internally generated services and expenses made necessary by Contractor's failure or refusal to perform. Owner may withhold that amount from the retention, or progress payments due the Contractor, pursuant to Section 9.5. If retention and payments withheld then or thereafter due the Contractor are not sufficient to cover that amount, the Contractor shall pay the difference to the Owner.

### **ARTICLE 3**

#### **THE CONTRACTOR**

##### **3.1 DEFINITION**

The Contractor is the person or entity identified as such in the Agreement and is referred to throughout the Contract Documents as if singular in number. The term "Contractor" means the Contractor or the Contractor's authorized representative. To the extent that any portion of the Work is provided with the Contractor's own forces, any reference to Subcontractors shall be equally applicable to the Contractor.

##### **3.2 SUPERVISION AND CONSTRUCTION PROCEDURES**

###### **3.2.1 CONTRACTOR**

The Contractor shall supervise and direct the Work using the Contractor's best skill and attention, which shall meet or exceed the standards in the industry. The Contractor shall be solely responsible for and have control over construction means, methods, techniques, sequences, procedures, and coordinating all portions of the Work under the Contract, unless Contract Documents give other specific instructions concerning these matters.

If part of the Project is performed by other contractors that Owner directly retains, Owner shall schedule and coordinate the activities of Contractor with the other contractors. Contractor agrees to accept the Owner's construction schedules, schedule updates, overall sequence and coordination of construction for the Project.

Contractor realizes that work by other contractors or Owner may occur simultaneously with Contractor's Work in any given area. Contractor is responsible for its own sequences that may occur within a given activity or set of activities. Contractor shall not commit or permit any act which will adversely affect the work of any other contractor or Owner. Contractor shall provide

layout of its Work at the request of any other contractor or Owner.

Specific duties of the Contractor shall be in accordance with Title 24 of the California Code of Regulations. Contractor shall fully comply with any and all reporting requirements of Education Code sections 17309 and 81141 in the manner prescribed by Title 24.

### **3.2.2 CONTRACTOR RESPONSIBILITY**

The Contractor shall be responsible to the Owner for acts and omissions of the Contractor's employees, Subcontractors, material and equipment suppliers, and their agents, employees, invitees, and other persons performing portions of the Work under direct or indirect contract with the Contractor or any of its Subcontractors.

### **3.2.3 OBLIGATIONS NOT CHANGED BY OTHERS' ACTIONS**

The Contractor shall not be relieved of obligations to perform the Work in accordance with the Contract Documents by the activities or duties of the Owner's representatives, including but not limited to any construction manager and the Architect, or the Inspector of Record; or by tests, inspections, or approvals required or performed by persons other than the Contractor.

### **3.2.4 CONTRACTOR RESPONSIBILITY FOR READINESS FOR WORK**

The Contractor shall be responsible for inspection of Work already performed under the Contract Documents to determine that such portions are in proper condition to receive subsequent work.

### **3.2.5 PROJECT MEETINGS**

During its Work, Contractor shall attend Owner's Project meetings as scheduled by the Contract Documents, or as otherwise instructed by Owner, to discuss the current status of the Work and Project and the future progress of the Work and the Project. Contractor shall have five (5) days after receipt of Owner's Project meeting minutes to provide written objections and suggested corrections.

## **3.3 SUPERINTENDENT**

### **3.3.1 FULL TIME SUPERINTENDENT**

The Contractor shall provide a competent superintendent and assistants as necessary, all of whom shall be reasonably proficient in speaking, reading and writing English and, who shall be in attendance at the Project Site during performance of the Work. The superintendent shall represent the Contractor, and communications given to the superintendent shall be as binding as if given to the Contractor.

### **3.3.2 STAFF**

The Contractor and each Subcontractor shall: furnish a competent and adequate staff as

necessary for the proper administration, coordination, supervision, and superintendence of its portion of the Work; organize the procurement of all materials and equipment so that the materials and equipment will be available at the time they are needed for the Work; and keep an adequate force of skilled workers on the job to Complete the Work in accordance with all requirements of the Contract Documents.

### **3.3.3 RIGHT TO REMOVE**

Owner shall have the right, but not the obligation, to require the removal from the Project of any superintendent, staff member, agent, or employee of any Contractor, Subcontractor, material or equipment supplier, etc., for cause.

## **3.4 LABOR AND MATERIALS**

### **3.4.1 CONTRACTOR TO PROVIDE**

Unless otherwise provided in the Contract Documents, the Contractor shall provide and pay for labor, material, equipment, tools, construction equipment and machinery, water, heat, utilities, transportation, and other facilities and services necessary for proper execution and Completion of the Work whether temporary or permanent and whether or not incorporated or to be incorporated in the Work. Owner shall have no responsibility for security of, or repair or replacement costs of, any and all material, equipment, tools, construction equipment, and machinery provided by Contractor pursuant to this Subsection.

### **3.4.2 QUALITY**

Unless otherwise specified, all materials and equipment to be permanently installed in the Project shall be new and shall be of such quality as required to satisfy the standards of the Contract Documents. The Contractor shall, if requested, promptly furnish satisfactory evidence as to kind and quality of all materials and equipment. All labor shall be performed by workers skilled in their respective trades, and the quality of their work shall meet whichever is the higher standard for their work: the standard in the industry or the standard in the Contract Documents.

### **3.4.3 REPLACEMENT**

Any work, materials, or equipment, which does not conform to these standards may be disapproved and rejected by the Owner, in which case, they shall be removed and replaced by the Contractor at no cost to the Owner.

### **3.4.4 DISCIPLINE**

The Contractor shall enforce strict discipline and good order among the Contractor's employees and other persons carrying out the Contract in accordance with paragraph 5.5.1 including, but not limited to, Subcontractors, and material or equipment suppliers retained for the Project.

### **3.5 WARRANTY**

For the period of one (1) year after Completion of the Work (see Sections 9.7.1, 12.2.5 and 12.2.6), the Contractor warrants to the Owner that material and equipment furnished under the Contract will be of good quality and new unless otherwise required or permitted by the Contract Documents, that the Work will be free from defects not inherent in the quality required or permitted, and that the Work will conform with the requirements of the Contract Documents. Work not conforming to these requirements, including substitutions not properly approved and authorized, may be considered defective. The Contractor's warranty does not cover damage or defect caused by abuse, modifications not executed by the Contractor, improper or insufficient maintenance, improper operation, or normal wear and tear under normal usage. If required by the Owner, the Contractor shall furnish satisfactory evidence as to the kind and quality of materials and equipment.

### **3.6 TAXES**

Contractor will pay all applicable Federal, State, and local taxes on all materials, labor, or services furnished by it, and all taxes arising out of its operations under the Contract Documents. Owner is exempt from Federal Excise Tax, and a Certificate of Exemption shall be provided upon request.

### **3.7 PERMITS, FEES AND NOTICES**

#### **3.7.1 PAYMENT**

The Contractor shall secure and pay for all permits and governmental fees, licenses, and inspections necessary for proper execution and Completion of the Work which are customarily secured after execution of the Contract and are legally required by any authority having jurisdiction over the Project, except those required by the Division of the State Architect (DSA). Owner shall be responsible for all testing and inspection as required by the DSA on-Site or within the distance limitations set forth in paragraph 13.5.2, unless a different mileage range is specified in the Contract Documents.

#### **3.7.2 COMPLIANCE**

The Contractor shall comply with and give notices required by any law, ordinance, rule, regulation, and lawful order of public authorities bearing on performance of the Work.

#### **3.7.3 CONTRACT DOCUMENTS**

It is not the Contractor's responsibility to ascertain that the Contract Documents are in accordance with any applicable law, statute, ordinance, building codes, rule, or regulation. However, if the Contractor knew, or should have known, or observes that portions of the Contract Document are at variance therewith, the Contractor shall promptly notify the Architect, any construction manager, and Owner in writing, and necessary changes shall be accomplished

by appropriate modification.

### 3.7.4 RESPONSIBILITY

If the Contractor performs any work that it knows, or should have known, is contrary to any law, statute, ordinance, building code, rule or regulation, the Contractor shall assume full responsibility for such work, and shall bear the attributable cost of correction and delays to the Work, other contractors' work, and the Project.

## 3.8 ALLOWANCES

### 3.8.1 CONTRACT

The Contractor shall include in the Contract Sum all allowances, including any general contingency allowance, stated in the Contract Documents. Items covered by specific allowances shall be supplied for such amounts and by such persons or entities as the Owner may direct, but the Contractor shall not be required to employ persons or entities against whom the Contractor makes reasonable and timely objection.

### 3.8.2 SCOPE

3.8.2.1 **Prompt Selection.** Materials and equipment under an allowance shall be selected promptly by the Owner to avoid delay to the Work.

3.8.2.2 **Cost.** Allowances shall cover the cost to the Contractor of materials and equipment delivered at the Site and all required taxes, less applicable trade discounts, etc., as delineated in paragraph 7.7.4.

3.8.2.3 **Cost Included in Contract Sum.** Contractor's costs for unloading and handling at the Site, labor, installation costs, overhead, profit, and other expenses contemplated for stated allowance amounts shall be included in the Contract Sum and not in the allowances.

3.8.2.4 **Contract Sum Adjustment.** Whenever Contractor seeks payment from an allowance and the requested costs are approved by Owner as compliant with the Contract Documents (including Sections 3.8.2.2 and 3.8.2.3, above), Owner may elect to pay the approved costs from the allowance, or pay the costs via Change Order. Any such allowance payment shall conform to the requirements of the Agreement and other Contract Documents.

## 3.9 CONTRACTOR'S CONSTRUCTION SCHEDULES

### 3.9.1 REQUIREMENTS

Before the Contractor's commencement of Work or within two (2) weeks of award of the Contract, whichever is earlier, Contractor shall prepare and submit for the Owner's, and any construction manager's, information the baseline construction schedule for the Work, which

shall conform to the Contract Documents' requirements.

Contractor shall submit an updated schedule by the first day of every month, and whenever else requested by the Owner. Each schedule update must include an accurate as-built schedule and the current as-planned schedule, both of which shall conform to the Contract Documents' requirements. Contractor shall submit its daily logs for the prior month with the updated schedule.

The original schedule and all updates shall conform, at a minimum, to industry standards for (a) critical path scheduling and (b) facilitation of Owner's Project management and evaluation of Contractor Claims for additional money or time.

The original schedule and all updates shall not exceed time limits (including milestone deadlines) under the Contract Documents and shall comply with the Contract Documents scheduling requirements and with any scheduling requirements the Owner provides to the Contractor at the beginning of the Work. The original schedule and all updates shall accurately reflect Work performed to date, reasonable dates for future Work; all construction activities (including procurement); the critical path schedule for Completion of the remainder of the Work; the logic, sequencing, and relationship between the construction activities, including each activity's predecessor and successor activities; and the percentage of the Work completed. The original schedule and all updates shall include a reasonable number of days for weather that is usual or common for each month, as time extensions are not available for such days (see Sections 4.5.5.3.2 and 8.4.1, below); and any failure by Contractor to include a reasonable number of such days, or by Owner to require Contractor to include a reasonable number of such days, shall not affect the reasonable number of such days to be used when determining time extensions under Sections 4.5.5.3.2 and 8.4.1, below.

The construction schedule shall be in the form of either a tabulation, chart, or graph, unless otherwise stated in Division 1 of the Specifications, and shall be in sufficient detail to show the chronological relationship of all activities of the Work including, but not limited to, estimated starting and completion dates of various activities, (including early and late dates and reasonable float for each activity), procurement of materials, the critical path, and scheduling of equipment. Float suppression techniques such as preferential sequencing, special lead/lag logic restraints, extended activity durations, or imposed dates shall be apportioned for the benefit of the Work. Whenever in the Contract Documents Contractor is required to provide a schedule and/or schedule updates, the Contractor shall provide the schedule and updates in electronic format as well as hard copy. Contractor shall be solely responsible for the accuracy, utility and reasonableness of all of its schedules. Owner's acceptance, approval or non-rejection of Contractor's schedules shall not affect Contractor's responsibility for its schedules.

The Contractor and Owner shall use any float on a "first come, first served" basis. The original schedule and updates shall reflect Contractor's and Owner's use of float. Float is not for the exclusive use or benefit of either Owner or Contractor, but it is a jointly owned expiring Work resource available to both parties as needed to meet schedule milestones. For the original schedule and updates, Contractor shall use a critical path network format with the critical paths clearly indicated. Contractor shall use an MS Project, Primavera, or an equivalent or better

program. Contractor shall include reports that sort and list the activities in order of increasing float and by early and late start dates. Contractor shall endeavor to label ten to thirty percent (10-30%) of the tasks as critical, but shall not label less than five (5%) or more than fifty (50%) as critical. Contractor shall use calendar days.

If any change in Contractor's method of operations will cause a change in the construction schedule, Contractor shall submit to Owner, Architect, and any construction manager, a revised construction schedule within seven (7) days of the change.

If, in the Owner's opinion, the Contractor is not prosecuting the Work at a rate sufficient to meet the Work schedule or a contractual milestone, or to Complete the Work within the Contract Time as adjusted by change orders or if the Contractor's actual progress falls behind the Work schedule or it is apparent to Owner that Contractor will not meet contractual milestones or Complete the Work within the Contract Time (as adjusted by change orders), the Owner may require that the Contractor prepare and submit a recovery plan. Contractor must submit a recovery plan within seven (7) days of a demand for the plan. At a minimum, the recovery plan must include a proposed schedule that shows Completion of the Work by the contractual milestones and within the Contract Time, as adjusted by change orders, or Completion by other dates Owner specifies in the demand for a recovery plan. The recovery plan shall state the corrective actions Contractor will undertake to implement it. The recovery plan shall also list any additional money that Contractor believes it should receive if Owner orders Contractor to fully or partially implement the recovery plan. If the Owner orders Contractor to implement the recovery plan, Contractor shall do so, but the order shall not constitute an admission by Owner that Contractor is entitled to additional money. To recover additional money, Contractor must comply with General Conditions Articles 4.5, 7 and 8.

All schedules Contractor submits shall be certified as true and correct, as follows:

I, \_\_\_\_\_ [*name of declarant*], declare the following:

\_\_\_\_\_ [*Contractor company name*] has contracted with \_\_\_\_\_ [*public entity name*] for the \_\_\_\_\_ Contract ("Contract"). \_\_\_\_\_ [*Contractor company name*] authorized me to prepare schedules for \_\_\_\_\_ [*public entity name*] for this Project, and I prepared the attached schedule. I am the most knowledgeable person at \_\_\_\_\_ [*Contractor company name*] regarding the scheduling of the Work for this Contract.

The attached schedule does not breach the Contract between \_\_\_\_\_ [*Contractor company name*] and \_\_\_\_\_ [*public entity name*] for this Project, does not violate any applicable law, satisfies all provisions of the Contract applicable to submission of schedules, only contains truthful and accurate as-built and as-planned dates of the Work (including supporting data), and is not a false claim.



The attached schedule is submitted in compliance with all laws applicable to submission of a Claim, including but not limited to California Penal Code section 72 (Fraudulent Claims), Government Code sections 12650 et seq. (False Claims Act; for example, Government Code section 12651(a)(7)), and Business and Professions Code sections 17200 et seq. (Unfair Business Practices Act). I am aware that submission or certification of false claims, or other Claims that violate law or the Contract, may lead to fines, imprisonment, and/or other serious legal consequences for myself and/or \_\_\_\_\_ [*Contractor company name*].

While preparing this declaration and schedule I consulted with others (including attorneys, consultants, or others who work for \_\_\_\_\_ [*Contractor company name*]) when necessary to ensure that the statements were true and correct.

I declare under the penalty of perjury under the laws of the State of California that the foregoing is true and correct. Executed \_\_\_\_\_, 20\_\_, at \_\_\_\_\_, California.

\_\_\_\_\_  
[signature]  
\_\_\_\_\_  
[name of declarant]

### 3.9.2 DSA OVERSIGHT PROCESS

In connection with the DSA Construction Oversight Process which includes inspection cards and review of changes to the DSA-approved construction documents, the Contractor must (a) include specific tasks in its baseline schedule to take into account these procedures since they are critical path issues; and (b) include a reasonable amount of float in the baseline schedule to accommodate the additional time required by these DSA procedures.

### 3.9.3 FAILURE TO MEET REQUIREMENTS

Failure of the Contractor to provide proper schedules may, at the sole discretion of Owner, constitute either grounds to withhold, in whole or in part, progress payments to the Contractor, or a breach of contract allowing Owner to terminate the Contract.

### 3.10 DOCUMENTS AND SAMPLES AT THE SITE

The Contractor shall maintain at the Site for the Owner one applicable copy of Titles 19 and 24 and record copy of the Drawings, Specifications, Addenda, Change Orders, and other Modifications, in good order and marked currently to record changes and selections made during construction. In addition, the Contractor shall maintain at the Site approved Shop Drawings,

Product Data, Samples, and similar required submittals. These documents shall be available to the Owner and shall be delivered to the Owner, or the Architect for delivery to the Owner, upon Completion of the Work.

### 3.11 SHOP DRAWINGS, PRODUCT DATA, AND SAMPLES

#### 3.11.1 SUBMITTALS DEFINED

3.11.1.1 **Shop Drawings.** The term “shop drawings” as used herein means drawings, diagrams, schedules, and other data, which are prepared by Contractor, Subcontractors, manufacturers, suppliers, or distributors illustrating some portion of the Work, and includes: illustrations; fabrication, erection, layout and setting drawings; manufacturer’s standard drawings; schedules; descriptive literature, instructions, catalogs, and brochures; performance and test data including charts; wiring and control diagrams; and all other drawings and descriptive data pertaining to materials, equipment, piping, duct and conduit systems, and methods of construction as may be required to show that the materials, equipment, or systems and their position conform to the requirements of the Contract Documents. The Contractor shall obtain and submit with the shop drawings all seismic and other calculations and all product data from equipment manufacturers. “Product data” as used herein are illustrations, standard schedules, performance charts, instructions, brochures, diagrams, and other information furnished by the Contractor to illustrate a material, product, or system for some portion of the Work. As used herein, the term “manufactured” applies to standard units usually mass-produced, and “fabricated” means items specifically assembled or made out of selected materials to meet individual design requirements. Shop drawings shall: establish the actual detail of all manufactured or fabricated items, indicate proper relation to adjoining work, amplify design details of mechanical and electrical systems and equipment in proper relation to physical spaces in the structure, and incorporate minor changes of design or construction to suit actual conditions.

3.11.1.2 **Samples.** The term “samples” as used herein are physical examples furnished by Contractor to illustrate materials, equipment, or quality and includes natural materials, fabricated items, equipment, devices, appliances, or parts thereof as called for in the Specifications, and any other samples as may be required by the Owner to determine whether the kind, quality, construction, finish, color, and other characteristics of the materials, etc., proposed by the Contractor conform to the required characteristics of the various parts of the Work. All Work shall be in accordance with the approved samples.

3.11.1.3 **Contractor’s Responsibility.** Contractor shall obtain and shall submit to Architect all required shop drawings and samples in accordance with Contractor’s “Schedule for Submission of Shop Drawings and Samples” provisions in Division 1 of the Specifications and in accordance with the Contractor’s original and updated schedules, and with such promptness as to cause no delay in its own Work or in that of any other contractor, Owner or subcontractor but in no event later than ninety (90) days after the execution of the Agreement. Contractor may be assessed \$100 a day for each day it is late in submitting a shop drawing or sample. No extensions of time will be granted to Contractor or any Subcontractor because of its failure to have shop drawings and samples submitted in accordance with the Schedule. Each Subcontractor shall submit all shop drawings, samples, and manufacturer’s descriptive data for the review of the Owner, the Contractor, and the Architect through the Contractor. By submitting shop drawings, product data, and samples, the Contractor or submitting party (if other

than Contractor) represents that it has determined and verified all materials, field measurements, field conditions, catalog numbers, related field construction criteria, and other relevant data in connection with each such submission, and that it has checked, verified, and coordinated the information contained within such submittals with the requirements of the Work and of the Contract Documents. At the time of submission, any deviation in the shop drawings, product data, or samples from the requirements of the Contract Documents shall be narratively described in a transmittal accompanying the submittal. However, submittals shall not be used as a means of requesting a substitution, the procedure for which is defined in paragraph 3.11.4, "Substitutions." Review by Owner and Architect shall not relieve the Contractor or any Subcontractor from its responsibility in preparing and submitting proper shop drawings in accordance with the Contract Documents. Contractor shall stamp, sign, and date each submittal indicating its representation that the submittal meets all of the requirements of the Contract Documents. Any submission, which in Owner's or Architect's opinion is incomplete, contains numerous errors, or has been checked only superficially by Contractor will be returned unreviewed for resubmission by the Contractor.

3.11.1.4 ***Extent of Review.*** In reviewing shop drawings, the Owner will not verify dimensions and field conditions. The Architect will review and approve shop drawings, product data, and samples for aesthetics and for conformance with the design concept of the Work and the information given in the Contract Documents. The Architect's review shall neither be construed as a complete check nor relieve the Contractor, Subcontractor, manufacturer, fabricator, or supplier from responsibility for any deficiency that may exist or from any departures or deviations from the requirements of the Contract Documents unless the Contractor has, in writing, called the Architect's attention to the deviations at the time of submission and the Architect has given specific written approval. The Architect's review shall not relieve the Contractor or Subcontractors from responsibility for errors of any sort in shop drawings or schedules, for proper fitting of the Work, or from the necessity of furnishing any Work required by the Contract Documents, which may not be indicated on shop drawings when reviewed. Contractor and Subcontractors shall be solely responsible for determining any quantities, whether or not shown on the shop drawings.

### 3.11.2 DRAWING SUBMISSION PROCEDURE

3.11.2.1 ***Transmittal Letter and Other Requirements.*** All shop drawings must be properly identified with the name of the Project and Contractor's name and dated, and each lot submitted must be accompanied by a letter of transmittal referring to the name of the Project and Contractor and to the Specification section number for identification of each item clearly stating in narrative form, as well as "clouding" on the submissions, all qualifications, departures, or deviations from the Contract Documents, if any. Shop drawings, for each section of the Work, shall be numbered consecutively, and the numbering system shall be retained throughout all revisions. All Subcontractor submissions shall be made through the Contractor. Each drawing shall have a clear space for the stamps of Architect and Contractor. Only shop drawings required to be submitted by the Contract Documents shall be reviewed.

3.11.2.2 ***Copies Required.*** Each submittal shall include one (1) legible, reproducible sepia and five (5) legible prints of each drawing, including fabrication, erection, layout and

setting drawings, and such other drawings as required under the various sections of the Specifications until final acceptance thereof is obtained. Subcontractor shall submit copies, in an amount as requested by the Contractor, of: manufacturers' descriptive data for materials, equipment, and fixtures, including catalog sheets showing dimensions, performance, characteristics, and capacities; wiring diagrams and controls; schedules; all seismic calculations and other calculations; and other pertinent information as required.

3.11.2.3 **Corrections.** The Contractor shall make any corrections required by Architect and shall resubmit as required by Architect the required number of corrected copies of shop drawings or new samples until approved. Contractor shall direct specific attention in writing or on resubmitted shop drawings to revisions other than the corrections required by the Architect on previous submissions. Professional services required for more than one (1) re-review of required submittals of shop drawings, product data, or samples are subject to charge to the Contractor pursuant to paragraph 4.4.

3.11.2.4 **Approval Prior to Commencement of Work.** No portion of the Work requiring a shop drawing or sample submission shall be commenced until the submission has been reviewed by Owner and approved by Architect unless specifically directed in writing by the Owner. All such portions of the Work shall be in accordance with approved shop drawings and samples.

### 3.11.3 SAMPLE SUBMISSIONS PROCEDURE

3.11.3.1 **Samples Required.** In case a considerable range of color, graining, texture, or other characteristics may be anticipated in finished products, a sufficient number of samples of the specified materials shall be furnished by the Contractor to indicate the full range of characteristics, which will be present in the finished products; and products delivered or erected without submittal and approval of full range samples shall be subject to rejection. Except for range samples, and unless otherwise called for in the various sections of the Specifications, samples shall be submitted in duplicate. All samples shall be marked, tagged, or otherwise properly identified with the name of the submitting party, the name of the Project, the purpose for which the samples are submitted, and the date and shall be accompanied by a letter of transmittal containing similar information, together with the Specification section number for identification of each item. Each tag or sticker shall have clear space for the review stamps of Contractor and Architect.

3.11.3.2 **Labels and Instructions.** Samples of materials, which are generally furnished in containers bearing the manufacturers' descriptive labels and printed application instructions, shall, if not submitted in standard containers, be supplied with such labels and application instructions.

3.11.3.3 **Architect's Review.** The Architect will review and, if appropriate, approve submissions and will return them to the Contractor with the Architect's stamp and signature applied thereto, indicating the appropriate action in compliance with the Architect's standard procedures.

3.11.3.4 **Record Drawings and Annotated Specifications.** The Contractor will prepare and maintain on a current basis an accurate and complete set of Record Drawings showing clearly all changes, revisions, and substitutions during construction, including, without limitation, field changes and the final location of all mechanical equipment, utility lines, ducts, outlets, structural members, walls, partitions, and other significant features, and Annotated Specifications showing clearly all changes, revisions, and substitutions during construction. A copy of such Record Drawings and Annotated Specifications will be delivered to Owner in accordance with the schedule prepared by Contractor. In the event of a specification that allows Contractor to elect one of several brands, makes, or types of material or equipment, the annotations shall show which of the allowable items the Contractor has furnished. The Contractor will update the Record Drawings and Annotated Specifications as often as necessary to keep them current but no less often than weekly. The Record Drawings and Annotated Specifications shall be kept at the Site and available for inspection by the Owner, Inspector of Record and the Architect. On Completion of the Contractor's Work and prior to Application for Final Progress Payment, the Contractor will provide one complete set of Record Drawings and Annotated Specifications to the Owner, certifying them to be a complete and accurate reflection of the actual construction conditions of the Work.

3.11.3.5 **Equipment Manuals.** Contractor shall obtain and furnish to the Owner three (3) complete sets of manuals containing the manufacturers' instructions for maintenance and operation of each item of equipment and apparatus furnished under the Contract Documents and any additional data specifically requested under the various sections of the Specifications for each division of the Work. The manuals shall be arranged in proper order, indexed, and placed in three-ring binders. At the Completion of its Work, the Contractor shall certify, by endorsement thereon, that each of the manuals is complete, accurate, and covers all of its Work. Prior to submittal of Contractor's Application for Final Progress Payment, and as a further condition to its approval by the Architect, each Subcontractor shall deliver the manuals, arranged in proper order, indexed, endorsed, and placed in three-ring binders, to the Contractor, who shall assemble these manuals for all divisions of the Work, review them for completeness, and submit them to the Owner through the Architect.

3.11.3.6 **Owner's Property.** All shop drawings and samples submitted shall become the Owner's property.

#### 3.11.4 SUBSTITUTIONS

3.11.4.1 **One Product Specified.** Unless the Specifications state that no substitution is permitted, whenever in the Contract Documents any specific article, device, equipment, product, material, fixture, patented process, form, method, or type of construction is indicated or specified by name, make, trade name, or catalog number, with or without the words "or equal," such specification shall be deemed to be used for the purpose of facilitating description of material, process, or article desired and shall be deemed to be followed by the words "or equal." Contractor may, unless otherwise stated, offer any material, process, or article, which shall be substantially equal or better in every respect to that so indicated or specified and will completely accomplish the purpose of the Contract Documents.

3.11.4.2 ***Two or More Products Specified.*** When two or more acceptable products are specified for an item of the Work, the choice will be up to the Contractor. Contractor shall utilize the same product throughout the Project. If a timely substitution request as set forth in Section 3.11.4.3 is not provided and an “or equal” substitution is requested, the Owner may consider the substitution if the product specified is no longer commercially available. If the Owner allows the substitution to be proposed pursuant to such an untimely request, the Contractor will be responsible for the professional fees incurred by the Architect or Architect’s consultants in reviewing the proposed substitution which fees may be withheld from progress payments and/or retention.

3.11.4.3 ***Substitution Request Form.*** Requests for substitutions of products, materials, or processes other than those specified must be made on the Substitution Request form available from the Owner prior to the date of the bid opening. Any Requests submitted less than fourteen (14) days prior to the date of the bid opening will not be considered, except as noted in paragraph 3.11.4.2. A Substitution Request must be accompanied by evidence as to whether or not the proposed substitution: is equal in quality and serviceability to the specified item; will entail no changes in detail and construction of related work; will be acceptable in consideration of the required design and artistic effect; will provide no cost disadvantage to Owner; and will require no excessive or more expensive maintenance, including adequacy and availability of replacement parts. The burden of proof of these facts shall be upon the Contractor. The Contractor shall furnish with its request sufficient information to determine whether the proposed substitution is equivalent including but not limited to all drawings, specifications, samples, performance data, calculations, and other information as may be required to assist the Architect and the Owner in determining whether the proposed substitution is acceptable. The final decision shall be the Owner’s. The written approval of the Owner, consistent with the procedure for Change Orders, shall be required for the use of a proposed substitute material. Owner may condition its approval of the substitution upon delivery to Owner of an extended warranty or other assurances of adequate performance of the substitution. If Contractor requests substitutions that require approval by the Division of the State Architect (“DSA”) or another governmental entity with jurisdiction, Contractor shall bear all risks of delay.

3.11.4.4 ***List of Manufacturers and Products Required.*** The Subcontractor shall prepare and submit to the Contractor within thirty (30) days of execution of the Subcontract comprehensive lists, in quadruplicate, of the manufacturers and products proposed for the Project, including information on materials, equipment, and fixtures required by the Contract Documents, as may be required for Contractor’s or Architect’s preliminary approval. Approval of such lists of products shall not be construed as a substitute for the shop drawings, manufacturer’s descriptive data, and samples, which are required by the Contract Documents, but rather as a base from which more detailed submittals shall be developed for the final review of the Contractor and the Architect.

### 3.11.5 DEFERRED APPROVALS

Deferred approvals shall be submitted and processed pursuant to the requirements of Division 1 of the Specifications. All risks of delay due to the Division of the State Architect’s, or any other governmental agency having jurisdiction, approval of a deferred approval shall be on the

requesting party.

### **3.12 CUTTING AND PATCHING**

#### **3.12.1 SCOPE**

The Contractor shall be responsible for cutting, fitting, or patching required to Complete the Work or to make its parts fit together properly.

#### **3.12.2 CONSENT**

The Contractor shall not damage or endanger a portion of the Work or fully or partially completed construction of the Owner or a separate contractor by cutting, patching, or otherwise altering such construction, or by excavation. The Contractor shall not cut or otherwise alter such construction by the Owner or a separate contractor except with written consent of the Owner and of such separate contractor; such consent shall not be unreasonably withheld. The Contractor shall not unreasonably withhold from the Owner or a separate contractor the Contractor's consent to cutting or otherwise altering the Work. All cutting shall be done promptly, and all repairs shall be made as necessary.

#### **3.12.3 STRUCTURAL MEMBERS**

New or existing structural members and elements, including reinforcing bars and seismic bracing, shall not be cut, bored, or drilled except by written authority of the Architect. Work done contrary to such authority is at the Contractor's risk, subject to replacement at its own expense and without reimbursement under the Contract. Agency approvals shall be obtained by the Architect, not by the Contractor.

#### **3.12.4 SUBSEQUENT REMOVAL**

Permission to patch any areas or items of the Work shall not constitute a waiver of the Owner's or the Architect's right to require complete removal and replacement of the areas or items of the Work if, in the opinion of the Architect or the Owner, the patching does not satisfactorily restore quality and appearance of the Work or does not otherwise conform to the Contract Documents. Any costs caused by defective or ill-timed cutting or patching shall be borne by the person or entity responsible.

### **3.13 CLEANING UP**

#### **3.13.1 CONTRACTOR'S RESPONSIBILITY**

The Contractor shall keep the Site and surrounding area free from accumulation of waste material or rubbish caused by operations under the Contract. The Site shall be maintained in a neat and orderly condition. All crates, cartons, paper, and other flammable waste materials shall be removed from Work areas and properly disposed of at the end of each day. The Contractor shall continuously remove from and about the Site the waste materials, rubbish, tools,

construction equipment, machinery, and materials no longer required for the Work.

### **3.13.2 FAILURE TO CLEANUP**

If the Contractor fails to clean up as provided in the Contract Documents, the Owner may do so, without prior notice to the Contractor and the cost thereof shall be invoiced to the Contractor and withheld from progress payments and/or retention. Each Subcontractor shall have the responsibility for the cleanup of its own Work. If the Subcontractor fails to clean up, the Contractor must do so.

### **3.13.3 CONSTRUCTION BUILDINGS**

When directed by the Owner or the Architect, Contractor and Subcontractor shall dismantle temporary structures, if any, and remove from the Site all construction and installation equipment, fences, scaffolding, surplus materials, rubbish, and supplies belonging to Contractor or Subcontractor. If the Contractor does not remove the tools, equipment, machinery, and materials within fifteen (15) days after Completion of its Work, then they shall be deemed abandoned, and the Owner can dispose of them for its own benefit in whatever way it deems appropriate. Contractor shall pay for any costs to dispose of the items.

### **3.14 ACCESS TO WORK**

The Contractor shall provide the Owner, the Architect, and the Inspector of Record, access to the Work in preparation and progress wherever located.

### **3.15 ROYALTIES AND PATENTS**

#### **3.15.1 PAYMENT AND INDEMNITY**

The Contractor shall pay all royalties and license fees. The Contractor shall defend suits or claims of infringement of patent rights and shall hold the Owner and the Architect harmless and indemnify them, to the extent not caused by the Owner's active negligence, sole negligence or willful misconduct, from loss on account thereof but shall not be responsible for such defense or loss when a particular design, process, or product of a particular manufacturer is required by the Contract Documents. However, if the Contractor has reason to believe the required design, process, or product is an infringement of a patent, the Contractor shall be responsible for such loss unless such information is promptly furnished to the Owner and Architect.

#### **3.15.2 REVIEW**

The review by the Owner or Architect of any method of construction, invention, appliance, process, article, device, or material of any kind shall be for its adequacy for the Work and shall not be an approval for the use by the Contractor in violation of any patent or other rights of any person or entity.

### **3.16 INDEMNIFICATION**



### 3.16.1 SCOPE: CONTRACTOR

To the fullest extent permitted by law, the Contractor shall defend, indemnify, and hold harmless the Owner, any construction manager, Architect, Architect's consultants, the Inspector of Record, the State of California, and their respective agents, employees, officers, volunteers, Boards of Trustees, members of the Boards of Trustees, and directors ("Indemnitees"), from and against claims, actions, damages, liabilities, losses (including but not limited to injury or death of persons, property damage, and compensation owed to other parties), and expenses (including but not limited to attorneys' fees and costs including fees of consultants) alleged by third parties against Indemnitees arising out of or resulting from the following: Contractor's, its Subcontractors', or its suppliers' performance of the Work, including but not limited to the Contractor's or its Subcontractors' use of the Site; the Contractor's or its Subcontractors' construction of the Project, or failure to construct the Project, or any portion thereof; the use, misuse, erection, maintenance, operation, or failure of any machinery or equipment including, but not limited to, scaffolds, derricks, ladders, hoists, and rigging supports, whether or not such machinery or equipment was furnished, rented, or loaned by any of the Indemnitees; or any act, omission, negligence, or willful misconduct of the Contractor or its Subcontractors or their respective agents, employees, material or equipment suppliers, invitees, or licensees but only to the extent caused in whole or in part by the acts or omissions of the Contractor, its Subcontractors, its suppliers, anyone directly or indirectly employed by any of them, or anyone for whose acts they may be liable, regardless of whether or not such claim, damage, loss, or expense is caused in part by a party indemnified hereunder. Such obligation shall not be construed to negate, abridge, or reduce other rights or obligations of indemnity, which would otherwise exist as to a party, person, or entity described in this paragraph. The obligation to defend, indemnify and hold harmless includes any claims or actions by third parties arising out of or resulting from Labor Code section 2810. Contractor shall have no obligation to defend or indemnify the Indemnitees against claims, actions, damages, liabilities, losses, and expenses caused by the active negligence, sole negligence or willful misconduct of Indemnitees. This indemnification shall apply to all liability, as provided for above, regardless of whether any insurance policies are applicable, and insurance policy limits do not act as a limitation upon the amount of the indemnification to be provided by the Contractor.

### 3.16.2 SCOPE: SUBCONTRACTORS

3.16.2.1 **Indemnity.** The Subcontractors shall defend, indemnify, and hold harmless the Indemnitees from and against claims, actions, damages, liabilities, and losses (including but not limited to injury or death of persons, property damage, and compensation owed to other parties), and expenses (including but not limited to attorneys' fees and costs including fees of consultants) alleged by third parties against Indemnitees arising out of or resulting from the following: Subcontractors' performance of the Work, including but not limited to the Subcontractors' use of the Site; the Subcontractors' construction of the Project or failure to construct the Project or any portion thereof; the use, misuse, erection, maintenance, operation, or failure of any machinery or equipment, including, but not limited to, scaffolds, derricks, ladders, hoists, and rigging supports, whether or not such machinery or equipment was furnished, rented, or loaned by any of the Indemnitees; or any act, omission, negligence, or willful misconduct of the Subcontractors or

their respective agents, employees, material or equipment suppliers, invitees, or licensees but only to the extent caused in whole or in part by the acts or omissions of the Subcontractors, anyone directly or indirectly employed by any of them, or anyone for whose acts they may be liable, regardless of whether or not such claim, damage, loss, or expense is caused in part by a party indemnified hereunder. Such obligation shall not be construed to negate, abridge, or reduce other rights or obligations of indemnity, which would otherwise exist as to a party, person, or entity described in this paragraph. This obligation to defend, indemnify and hold harmless includes any claims or actions by third parties arising out of or resulting from Labor Code section 2810. Subcontractors shall have no obligation to defend or indemnify the Indemnitees against claims, actions, damages, liabilities, losses, and expenses caused by the active negligence, sole negligence or willful misconduct of Indemnitees. This indemnification shall apply to all liability, as provided for above, regardless of whether any insurance policies are applicable, and insurance policy limits do not act as a limitation upon the amount of the indemnification to be provided by the Subcontractors.

**3.16.2.2 *Joint and Several Liability.*** In the event more than one Subcontractor is connected with an accident or occurrence covered by this indemnification, then all such Subcontractors shall be jointly and severally responsible to each of the Indemnitees for indemnification, and the ultimate responsibility among such indemnifying Subcontractors for the loss and expense of any such indemnification shall be resolved without jeopardy to any Indemnitee. The provisions of the indemnity provided for herein shall not be construed to indemnify any Indemnitee for its own negligence if not permitted by law or to eliminate or reduce any other indemnification or right which any Indemnitee has by law or equity.

### **3.16.3 NO LIMITATION**

The Contractor's and the Subcontractor's obligation to indemnify and defend the Indemnitees hereunder shall include, without limitation, any and all claims, damages, and costs: for injury to persons and property (including loss of use), and sickness, disease or death of any person; for breach of any warranty, express or implied; for failure of the Contractor or the Subcontractor to comply with any applicable governmental law, rule, regulation, or other requirement; and for products installed in or used in connection with the Work.

### **3.17 OWNER AS INTENDED BENEFICIARY**

The Owner is an intended beneficiary of any architectural or engineering work secured by, or performed by, the Contractor to fulfill its obligations under the Contract. Contractor shall state in its contracts with architectural or engineering consultants that their work is for the intended benefit of the Owner.

### **3.18 NOTICE OF EXCUSE FOR NONPERFORMANCE**

If Contractor believes that acts or omissions of Owner (including but not limited to Owner caused delay) have prevented Contractor from performing the Work as required by the Contract Documents and Contractor intends to rely on Owner's acts or omissions and Civil Code section 1511(1) as reasons to excuse Contractor's nonperformance or to support, among other things,

Contractor's requests for time extensions under section 4.5, below, Contractor shall provide written notice of the excuse within five (5) days of the Owner's acts or omissions. If Contractor fails to timely submit the written notice, Contractor shall have waived any right to later rely on the acts or omissions as a defense to Contractor's nonperformance or as the basis for a time extension, regardless of the merits of the defense or time extension. Contractor will not have satisfied a condition precedent or exhausted administrative remedies. Contractor acknowledges that these written notices are of critical importance to the Owner's management of the Work and Project and the mitigation of costs and delays to the Work and Project.

### **3.19 RECOVERY OF COSTS, DAMAGES, OR TIME EXTENSIONS FROM OWNER**

Notwithstanding any other provisions of the Contract Documents, Contractor expressly waives its right to recover any special, consequential, or indirect damages from Owner in relation to this Contract or the Project. Contractor may only recover general (also known as direct) damages from Owner to the extent allowed by the Contract Documents.

A Notice of Potential Change, Change Order Request and, if necessary, a Claim (see Sections 4.5, 7.2, and 7.6, below) are the exclusive means for Contractor to preserve its rights to recover any costs, damages, or time extensions related to the Contract or the Project from Owner, including but not limited to alleged breaches of contract based on extra work, delay, wrongful withholding, or wrongful termination. Contractor's failure to comply with the Contract Documents' procedures for a COR, CO, and Claim (including but not limited to Sections 4.5, 7.2, 7.6, and 7.7, below) may completely waive Contractor's rights to recovery any such costs or damages.

### **3.20 USE OF FEDERAL FUNDS**

If federal funds are being used either in whole or in part for this Project (see the Instructions to Bidders), then the Project is subject to, and Contractor must comply with, all applicable federal laws including but not limited to the federal regulations set forth in CFR Title 2, Part 200. Accordingly, Contractor agrees to comply with all such federal requirements, including but not limited to the following:

A. **EQUAL EMPLOYMENT OPPORTUNITY.** Contractor agrees to comply with and be bound by Title 14, CFR, Section 60-1.4(b), in accordance with Executive Order 11246, "Equal Employment Opportunity" ([30 FR 12319](#), [12935](#), [3 CFR Part, 1964-1965](#) Comp., p. 339), as amended by Executive Order 11375, "Amending Executive Order 11246 Relating to Equal Employment Opportunity," and implementing regulations at [41 CFR part 60](#), "Office of Federal Contract Compliance Programs, Equal Employment Opportunity, Department of Labor," the terms of which are incorporated by reference as though set forth in full herein.

B. **DAVIS-BACON ACT.** If the Contract Price exceeds \$2,000, Contractor agrees to comply with and be bound by, and assist Owner in ensuring compliance with, the Davis-Bacon Act, as applicable. (40 U.S.C. §§ 3141-3144; 3146-3148 as supplemented by Department of Labor regulations (29 CFR Part 5, "Labor Standards Provisions Applicable to Contracts Covering Federally Financed and Assisted Construction").) Contractor is required to pay wages to laborers

and mechanics at a rate not less than the prevailing wages specified in a wage determination made by the Secretary of Labor. Additionally, Contractor is required to pay wages not less than once a week. Furthermore, pursuant to the Copeland “Anti-Kickback” Act (40 U.S.C. 3145), as supplemented by Department of Labor regulations (29 CFR Part 3, “Contractors and Subcontractors on Public Building or Public Work Financed in Whole or in Part by Loans or Grants from the United States”), Contractor is prohibited from inducing, by any means, any person employed in the construction, completion, or repair of public work, to give up any part of the compensation to which he or she is otherwise entitled.

C. **CONTRACT WORK HOURS AND SAFETY STANDARDS ACT.** If the Contract Price exceeds \$100,000 that involve the employment of mechanics or laborers, Contractor agrees to comply with and be bound by, and assist Owner in ensuring compliance with, the Contract Work Hours and Safety Standards Act, as applicable. (40 U.S.C. 3702 and 3704, as supplemented by Department of Labor regulations (29 CFR Part 5).) Under 40 U.S.C. 3702 of the Act, each contractor must be required to compute the wages of every mechanic and laborer on the basis of a standard work week of 40 hours. Work in excess of the standard work week is permissible provided that the worker is compensated at a rate of not less than one and a half times the basic rate of pay for all hours worked in excess of 40 hours in the work week. The requirements of 40 U.S.C. 3704 are applicable to construction work and provide that no laborer or mechanic must be required to work in surroundings or under working conditions which are unsanitary, hazardous or dangerous. These requirements do not apply to the purchases of supplies or materials or articles ordinarily available on the open market, or contracts for transportation or transmission of intelligence.

D. **RIGHTS TO INVENTIONS MADE UNDER A CONTRACT AGREEMENT.** For all contracts that meet the definition of “funding agreement” under 37 CFR § 401.2 (a) and the recipient or subrecipient wishes to enter into a contract with a small business firm or nonprofit organization regarding the substitution of parties, assignment or performance of experimental, developmental, or research work under that “funding agreement,” Contractor agrees to comply with and be bound by, and assist Owner in ensuring compliance with, 37 CFR Part 401, “Rights to Inventions Made by Nonprofit Organizations and Small Business Firms Under Government Grants, Contracts and Cooperative Agreements,” the provisions of which are incorporated herein by this reference, and any implementing regulations issued by the awarding agency, as applicable.

E. **CLEAN AIR AND FEDERAL WATER POLLUTION ACT CONTROL.** If the Contract Price exceeds \$150,000, Contractor agrees to comply with and be bound by, and assist Owner in ensuring compliance with all applicable standards, orders or regulations issued pursuant to the Clean Air Act (42 U.S.C. 7401-7671q) and the Federal Water Pollution Control Act as amended (33 U.S.C. 1251-1387). Any violations must be reported to the Federal awarding agency and the Regional Office of the Environmental Protection Agency (EPA).

F. **DEBARMENT AND SUSPENSION.** Contractor represents and warrants that it is not listed on the government-wide exclusions in the System for Award Management (SAM), and Contractor agrees to comply with and be bound by, and assist Owner in ensuring compliance with, the OMB guidelines at 2 CFR 180 that implement Executive Orders 12549 (3 CFR part 1986 Comp., p. 189) and 12689 (3 CFR part 1989 Comp., p. 235), “Debarment and Suspension.” SAM

Exclusions contains the names of parties debarred, suspended, or otherwise excluded by agencies, as well as parties declared ineligible under statutory or regulatory authority other than Executive Order 12549.

G. BYRD ANTI-LOBBYING AMENDMENT. If the Contract Price exceeds \$100,000, Contractor agrees to comply with and be bound by, and assist Owner in ensuring compliance with, the Byrd Anti-Lobbying Amendment (31 U.S.C. § 1352). Contractor shall file the declaration and certification required by 31 U.S.C. § 1352(b).

H. PROCUREMENT OF RECOVERED MATERIALS. Contractor agrees to comply with, and be bound by, and assist Owner in ensuring compliance with, 2 CFR Section 200.323, as applicable.

I. PROHIBITION ON CERTAIN TELECOMMUNICATIONS AND VIDEO SURVEILLANCE SERVICES OR EQUIPMENT. Contractor agrees to comply with, and be bound by, and assist Owner in ensuring compliance with, 2 CFR Section 200.216, as applicable.

J. DOMESTIC PREFERENCES FOR PROCUREMENT. Contractor agrees to comply with, and be bound by, and assist Owner in ensuring compliance with, 2 CFR Section 200.322, as applicable. 2 CFR Section 200.322 requires Contractor to provide a preference for the purchase, acquisition, or use of goods, products, or materials produced in the United States (including but not limited to iron, aluminum, steel, cement, and other manufactured products), to the greatest extent practicable.

K. CONTRACTING WITH SMALL AND MINORITY BUSINESSES, WOMEN'S BUSINESS ENTERPRISES, AND LABOR SURPLUS AREA FIRMS. Contractor agrees to comply with, and be bound by, and assist Owner in ensuring compliance with, 2 CFR Section 200.321, as applicable. 2 CFR Section 200.321 requires Contractor to take the affirmative steps listed in 2 CFR Section 200.321 paragraphs (b)(1) through (5) to assure that minority businesses, women's business enterprises, and labor surplus area firms are used when possible.

L. SAFETY AND HEALTH STANDARDS. As required by 34 CFR 75.609, Contractor agrees to comply with and be bound by, and assist Owner in ensuring compliance with, the standards under the Federal Occupational Safety and Health Act of 1970 (29 U.S.C.A., Section 651 et seq.) and State and local codes to the extent that they are more stringent.

M. ENERGY CONSERVATION. As required by 34 CFR 75.616, Contractor agrees to construct facilities to maximize the efficient use of energy and to comply with and be bound by, and assist OWNER in ensuring compliance with, the following standards of the American Society of Heating, Refrigerating, and Air Conditioning Engineers (ASHRAE) set forth in 34 CFR 75.616. Contractor shall also comply with and be bound by, and assist Owner in ensuring compliance with, the mandatory standards and policies relating to energy efficiency which are contained in the state energy conservation plans issued in compliance with the Energy Policy and Conservation Act (Pub. L 94-163, 89 Stat. 871).

N. If any provision is required by federal law, or by the federal grant program funding such

project, to be included in the Contract Documents, such provisions shall be deemed by the parties to have been included.

## **ARTICLE 4**

### **ADMINISTRATION OF THE CONTRACT**

#### **4.1 ARCHITECT**

##### **4.1.1 DEFINITION**

The Architect is the person lawfully licensed to practice architecture or an entity lawfully practicing architecture identified as such in the Agreement and is referred to throughout the Contract Documents as if singular in number. The term “Architect” means the Architect or the Architect’s authorized representative, and shall also refer to all consultants under the Architect’s direction and control.

##### **4.1.2 MODIFICATION**

To the extent the Contract Documents indicate that Owner has assigned duties or responsibilities to the Architect, Owner reserves the right at all times to reassign such duties or responsibilities to different Owner representatives.

##### **4.1.3 TERMINATION**

In the case of the termination of the Architect, the Owner may appoint an architect or another construction professional or may perform such functions with its own licensed professional personnel. The status of the replacement Architect under the Contract Documents shall be that of the former architect.

#### **4.2 ARCHITECT’S ADMINISTRATION OF THE CONTRACT**

##### **4.2.1 STATUS**

The Architect will provide administration of the Contract and may be one of several Owner’s representatives during construction, through release of all retention, and during the one (1) year period following the commencement of any warranties. The Architect will advise and consult with the Owner. The Architect will have authority to act on behalf of the Owner only to the extent set forth in the Owner/Architect agreement. The Architect will have all responsibilities and power established by law, including California Code of Regulations, Title 24, to the extent set forth in the Owner/Architect agreement.

##### **4.2.2 SITE VISITS**

The Architect will visit the Site at intervals necessary in the judgment of the Architect or as otherwise agreed by the Owner and the Architect in writing to become generally familiar with

the progress and quality of the completed Work and to determine in general if the Work is being performed in a manner indicating that the Work, when Completed, will be in accordance with the Contract Documents.

#### **4.2.3 LIMITATIONS OF CONSTRUCTION RESPONSIBILITY**

The Contractor shall not be relieved of obligations to perform the Work in accordance with the Contract Documents either by activities or duties of the Architect in the Architect's administration of the Contract Documents, or by tests, inspections, or approvals required or performed by persons other than the Contractor.

#### **4.2.4 COMMUNICATIONS FACILITATING CONTRACT ADMINISTRATION**

The Owner and the Contractor shall communicate through the Architect, unless there is a construction manager for the Project or the Owner directs otherwise. Communications between Owner and Subcontractors or material or equipment suppliers shall be through the Contractor.

#### **4.2.5 PAYMENT APPLICATIONS**

The Contractor shall submit payment applications to the Architect, unless there is a construction manager for the Project or the Owner directs otherwise.

#### **4.2.6 REJECTION OF WORK**

The Architect, Inspector of Record, any construction manager and others may recommend to the Owner that the Owner reject Work which does not conform to the Contract Documents or that the Owner require additional inspection or testing of the Work in accordance with paragraph 13.5.5, whether or not the Work is fabricated, installed, or completed. However, no recommendation shall create a duty or responsibility to the Contractor, Subcontractors, material and equipment suppliers, their agents or employees, or other persons performing portions of the Work.

#### **4.2.7 CHANGE ORDERS**

The Architect may prepare change orders and construction change directives and may authorize minor changes in the Work.

#### **4.2.8 WARRANTIES UPON COMPLETION**

The Architect in conjunction with the Inspector of Record, or as otherwise directed by Owner, will conduct field reviews of the Work to determine the date of Completion, shall receive and forward to the Owner for the Owner's review and records, written warranties and related documents required by the Contract and assembled by the Contractor. The handling by the Architect of such warranties, maintenance manuals, or similar documents shall not diminish or transfer to the Architect any responsibilities or liabilities required by the Contract Documents of

the Contractor or other entities, parties, or persons performing or supplying the Work.

Except as may be otherwise directed by Owner, the Architect will conduct a field review of the Contractor's comprehensive list of items to be completed or corrected for development of a punch list and one (1) follow-up field review if required. The cost incurred by the Owner for further field reviews or the preparation of further punch lists by the Architect shall be invoiced to the Contractor and withheld from payment and/or retention.

#### 4.2.9 INTERPRETATION

The Architect, Inspector of Record, any construction manager, the Owner or any independent consultant of Owner, as Owner deems appropriate, will interpret and decide matters concerning performance under and requirements of the Contract Documents on written request of the Contractor. The Owner's response to such requests will be made with reasonable promptness, while allowing sufficient time to permit adequate review and evaluation of the request.

#### 4.2.10 ADDITIONAL INSTRUCTIONS

4.2.10.1 *Architect's Interpretations and Decisions.* Interpretations and decisions of the Architect will be consistent with the intent of and reasonably inferable from the Contract Documents and will be in writing or in the form of drawings. When making such interpretations of and decisions regarding the Contract Documents, the Architect will endeavor to secure faithful performance under the Contract Documents by both the Owner and the Contractor and will not show partiality to either. The Work shall be executed in conformity with, and the Contractor shall do no work without, approved drawings, Architect's clarifying instructions, and/or submittals.

4.2.10.2 *Typical Parts and Sections.* Whenever typical parts or sections of the Work are completely detailed on the Drawings, and other parts or sections which are essentially of the same construction are shown in outline only, the complete details shall apply to the Work which is shown in outline.

4.2.10.3 *Dimensions.* Dimensions of Work shall not be determined by scale or rule. Figured dimensions shall be followed at all times. If figured dimensions are lacking on Drawings, Architect shall supply them on request. The Owner's decisions on matters relating to aesthetic effect will be final if consistent with the Contract Documents.

### 4.3 INSPECTOR OF RECORD

#### 4.3.1 GENERAL

One or more Project inspectors ("Inspector of Record") employed by the Owner and approved by the Division of the State Architect will be assigned to the Work in accordance with the requirements of Title 24 of the California Code of Regulations. The Inspector of Record's duties will be as specifically defined in Title 24.



#### **4.3.2 INSPECTOR OF RECORD'S DUTIES**

All Work shall be under the observation of or with the knowledge of the Inspector of Record. The Inspector of Record shall have free access to any or all parts of the Work at any time. The Contractor shall furnish the Inspector of Record such information as may be necessary to keep the Inspector of Record fully informed regarding progress and manner of work and character of materials. Such observations shall not, in any way, relieve the Contractor from responsibility for full compliance with all terms and conditions of the Contract, or be construed to lessen to any degree the Contractor's responsibility for providing efficient and capable superintendence. The Inspector of Record is not authorized to make changes in the drawings or specifications nor shall the Inspector of Record's approval of the Work and methods relieve the Contractor of responsibility for the correction of subsequently discovered defects, or from its obligation to comply with the Contract Documents.

#### **4.3.3 INSPECTOR OF RECORD'S AUTHORITY TO REJECT OR STOP WORK**

The Inspector of Record shall have the authority to reject work that does not comply with the provisions of the Contract Documents. In addition, the Inspector of Record may stop any work which poses a probable risk of harm to persons or property. The Contractor shall instruct its employees, Subcontractors, material and equipment suppliers, etc., accordingly. The absence of any Stop Work order or rejection of any portion of the Work shall not relieve the Contractor from any of its obligations pursuant to the Contract Documents.

#### **4.3.4 INSPECTOR OF RECORD'S FACILITIES**

Within seven (7) days after notice to proceed, the Contractor shall provide the Inspector of Record with temporary facilities, including any requirements stated in Division 1 of the Specifications.

#### **4.4 RESPONSIBILITY FOR ADDITIONAL CHARGES INCURRED BY THE OWNER FOR PROFESSIONAL SERVICES**

If at any time prior to the Completion of the requirements under the Contract Documents, through no fault of its own, the Owner is required to provide or secure additional professional services for any reason by any act or omission of the Contractor, the Contractor shall be invoiced by the Owner for any actual costs incurred for any such additional services, which costs may, among other remedies, be withheld from the progress payments and/or retention. Such invoicing shall be independent from any other Owner remedies, including but not limited to liquidated damages. If payments then or thereafter due to the Contractor are not sufficient to cover such amounts, the Contractor shall pay the difference to the Owner. Additional services shall include, but shall not be limited to, the following:

- A. Services made necessary by the default of the Contractor.

- B. Services made necessary due to the defects or deficiencies in the Work of the Contractor.
- C. Services required by failure of the Contractor to perform according to any provision of the Contract Documents.
- D. Services in connection with evaluating substitutions of products, materials, equipment, Subcontractors proposed by the Contractor, and making subsequent revisions to drawings, specifications, and providing other documentation required (except for the situation where the specified item is no longer manufactured or available).
- E. Services for evaluating and processing Claims submitted by the Contractor in connection with the Work outside the established Change Order process.
- F. Services required by the failure of the Contractor to prosecute the Work in a timely manner in compliance within the specified time for Completion.
- G. Services in conjunction with the testing, adjusting, balancing and start-up of equipment other than the normal amount customarily associated for the type of Work involved.
- H. Services in conjunction with more than one (1) re-review of required submittals of shop drawings, product data, and samples.

#### **4.5 NOTICES OF POTENTIAL CHANGE, CHANGE ORDER REQUESTS, AND CLAIMS**

If the Contractor identifies the potential for extra work, delay in the critical path schedule, or the need for additional money or time, or if the Contractor requests additional money or time on any grounds (including but not limited to an alleged breach of an implied warranty of the correctness of the plans and specifications [*Souza & McCue Construction Co. v. Superior Court* (1962) 57 Cal.2d 508]), or if the Contractor believes that Owner has failed to pay amounts due or otherwise breached the Contract, or otherwise believes that it is entitled to a modification of the Contract terms and conditions, then Contractor shall follow the procedures in this Section 4.5 and Article 7, otherwise Contractor shall have waived its rights to pursue those issues and any later attempts to recover money or obtain a modification shall be barred. Contractor specifically acknowledges the Owner's and public's interest in, and need to know of, potential changes and disputes as early as possible so Owner can investigate, mitigate and resolve adverse cost and time impacts, if any. It is Contractor's obligation to know and comply with the requirements of the Contract Documents, including but not limited to Section 4.5 and Articles 7 and 8, and Owner has no obligation to notify Contractor of any failure to comply with those requirements.

#### 4.5.1 NOTICE OF POTENTIAL CHANGE

Contractor shall submit a written Notice of Potential Change for extra work, critical path delay, or additional money or time. Contractor shall submit written Notices of Potential Change to Owner within five (5) days of the earlier of (a) Contractor becoming aware of the issue creating a potential change, or (b) the date by which Contractor should have become aware of the issue creating a potential change; unless the issues are, or may soon be, adversely affecting the costs or critical path of the Work, in which case the Contractor must submit the written notice without delay so the Owner may take immediate action to mitigate cost and schedule impacts of the change, if any. The written notice shall explain the nature of the potential change so the Owner may take action to mitigate costs and schedule impacts, if necessary.

When submitting a written Notice of Potential Change based on extra work, Contractor shall not perform the extra work until directed in writing to do so by Owner. When submitting a written Notice of Potential Change for an issue of critical path delay, Contractor shall proactively mitigate the effects of the alleged delay as much as reasonably possible so as to minimize any impact to the schedule, until otherwise directed by Owner. If Contractor intends to rely on Owner's acts or omissions in support of a request for a time extension, then Contractor must also provide the notice set forth in section 3.18, above.

Failure to timely submit a written Notice of Potential Change shall constitute a complete waiver by Contractor of any right to later submit a change order request or pursue a Claim on that issue, or to later pursue any additional money or time extensions in any manner related to that issue, regardless of the merits. Contractor will not have satisfied a condition precedent or exhausted administrative remedies. Contractor acknowledges that these written notices are of critical importance to the Owner's Work and Project management and the mitigation of Work and Project costs and delays.

#### 4.5.2 CHANGE ORDERS REQUESTS

If, after submitting a written Notice of Potential Change pursuant to Section 4.5.1, Contractor continues to believe that it is entitled to additional money or time (including but not limited to grant of a time extension; payment of money or damages arising from work done by, or on behalf of, the Contractor, payment of which is not otherwise expressly provided for or the claimant is not otherwise entitled to; or an amount the payment of which is disputed by the Owner) based on an issue, then Contractor shall submit a Change Order Request ("COR"; see Section 7.6.1) to Owner within twenty (20) days of the earlier of (i) Contractor becoming aware of the issue creating a potential change, or (ii) the date by which Contractor should have become aware of the issue creating a potential change. A rejection at any time or a lack of a rejection by Owner of a Notice of Potential Change does not affect the timeline for submitting a COR.

Failure to timely submit a COR related to an issue, or failure to comply with any of the COR requirements in the Contract shall constitute a complete waiver by Contractor of any right to later submit a COR or Claim on that issue, or to later pursue any additional money (or time) in any manner related to that issue, regardless of the merits. Contractor will not have satisfied a condition precedent or exhausted administrative remedies.

The COR shall state the grounds for the additional money or time requested and the amount of money or time requested, and Contractor shall include all information and documentation supporting the COR, including but not limited to calculations and analysis that demonstrate that the requested money or time is allowed by the applicable contract provisions and law. For any money or time other than the money and time specifically requested in the COR, Contractor will have completely waived its rights to recover such additional money or time (Contractor will not have satisfied a condition precedent or exhausted administrative remedies). If the COR requests time, then the COR must identify the number of days of time being requested and must include some critical path schedule analysis to support the number of days requested. Contractor may not reserve its rights, whether in a COR or other document, to submit a COR at a later time or in a manner other than as required by the Contract Documents. Any inclusion of a reservation of rights in a COR shall be grounds for rejection of the COR.

In the event that costs or delay are continuing to accrue at the time that a COR is required to be submitted, Contractor must still timely submit the COR with all available information and documentation supporting the COR as described above, and Contractor shall identify the costs or delay that are continuing. For continuing costs, the COR must include an estimate of when the extra work is expected to conclude and the total costs that will be incurred by the time that the extra work is expected to conclude. For continuing delay, the COR must include a schedule and delay analysis of when Contractor estimates that the delay will cease, what the final time extension request is estimated to be, and an estimate of the total of delay damages, if any, that will be requested. When the continuing cost or delay ends, within ten (10) days Contractor shall submit an updated COR that states the final dollar amount and/or time extension requested and that includes all required information and documentation. Failure to submit such final COR shall act as a waiver as described above.

Contractor shall certify each COR that it submits, including the initial COR and final COR for a continuing cost or delay, using the form set forth in Section 4.5.5.1, except that every reference to "Claim" shall be changed to "COR." If a COR is submitted without certification, a certification can still be submitted within the timelines set forth in the first paragraph of Section 4.5.2. If the COR is not timely certified, Contractor will have completely waived its rights to any money or time for that issue. Contractor will not have satisfied a condition precedent or exhausted administrative remedies. A certification of an initial COR for a continuing cost or delay shall include a statement that "Any estimates in the attached initial COR for a continuing cost or delay are based on true and correct facts and reasonable assumptions, as explained in the initial COR."

The Owner may accept the entire COR, accept part of the COR and reject the remainder, reject the entire COR, or request additional information. If the Owner does not respond within thirty (30) days of submission of the COR by accepting the entire COR, accepting part of the COR and rejecting the remainder, or requesting additional information, the entire COR shall be deemed rejected as of the thirtieth (30th) day. In the case of continuing costs or delay, the 30-day deadline in the previous sentence shall not apply to the initial COR; it will only apply to the final COR (see above). If the Owner requests additional information within thirty (30) days of submission, then the Contractor shall submit the information within fifteen (15) days of the date

of the request and the Owner shall have fifteen (15) days after the receipt of the additional information to accept or reject (in whole or in part) the COR. If the Contractor fails to submit the information within fifteen (15) days, then the COR shall be deemed rejected. If the Owner fails to respond within fifteen (15) days after the submission of additional information, the entire COR shall be deemed rejected as of the fifteenth (15th) day.

#### 4.5.3 DEFINITION OF CLAIM

A “Claim” is a separate demand by the Contractor sent by registered or certified mail, return receipt requested, for (a) a time extension, including, without limitation, a request for relief from damages or penalties for delay assessed by Owner under the Contract Documents; (b) payment by Owner of money or damages arising from work done by, or on behalf of, the Contractor pursuant to the Contract Documents, and payment of which is not otherwise expressly provided for or the claimant is not otherwise entitled to (including but not limited to a claim for damages based on misleading or incomplete plans or specifications); or (c) an amount the payment of which is disputed by the Owner. A Claim includes any claim within the scope of Public Contract Code sections 9204 or 20104 et seq., and any alleged violation of a prompt payment statute. Resubmittal in any manner of a COR which was previously rejected under Section 4.5.2 constitutes a Claim, whether the COR was rejected in whole or in part, and whether the COR was rejected expressly or deemed rejected by Owner inaction. A Claim includes any dispute Contractor may have with the Owner, including one which does not require a Notice of Potential Change or COR under Sections 4.5.1 and 4.5.2, and including any alleged breach of contract by the Owner (such as wrongful withholding of a payment by the Owner). A Claim under this Article 4.5 shall also constitute a claim for purposes of the California False Claims Act. In the event of a conflict between a Claims provision in Division 1 of the Specifications and Section 4.5, Section 4.5 shall take precedence.

The Notice of Potential Change and COR procedures above are less formal procedures which precede the more formal Claim. A Notice of Potential Change does not constitute a Claim. A COR does not constitute a Claim; **except that** if insufficient time remains before the Claim deadline (see Article 4.5.4) for Contractor to submit a COR and for Owner to process and reject the COR under Article 4.5.2, then either (1) Contractor may submit a COR which Owner shall treat as a Claim, but only if the COR complies with all requirements in this Article 4.5 and Article 7 for COR’s and Claims, or (2) a COR is not required so long as a Claim complying with this Article 4.5 is timely submitted.

A Claim does not include vouchers, invoices, progress payment applications, or other routine or authorized forms of requests for progress payments on the Contract; however, those documents remain “claims” for purposes of the California False Claims Act. A Claim does not include a Government Code Claim. (“Government Code Claim” means a claim under Government Code sections 900 et seq. and 910 et seq.)

#### 4.5.4 TIME FOR SUBMITTING CLAIM; WAIVER

Contractor shall submit a Claim to the Owner’s construction manager (or in the absence of a construction manager, to Architect) and Owner within the earlier of (a) fifteen (15) days after

Owner's rejection of a COR in whole or in part, or (b) fifteen (15) days after a COR being deemed rejected, pursuant to Section 4.5.2 above. If the Claim is not based on an issue for which a COR would be required (such as wrongful withholding by the Owner), then Contractor shall submit the Claim within fifteen (15) days after the date on which Contractor knew, or should have known, about the issue on which the Claim is based. If a Claim has not been submitted as of the date that the Contractor Completes the Work and submittal of the Claim was not yet required under the Contract Documents, then the Claim shall be submitted within seven (7) days of Completion of the Work; and such Claim shall not be barred due to lack of a Notice of Potential Change or COR if the deadline for the Notice of Potential Change or COR was after Completion of the Work.

In addition, within seven (7) days of Completion of the Work, Contractor shall submit to Owner, in writing, a list and summary of all Claims for money or time extensions under or arising out of this Contract which were timely filed, which were fully compliant with the Contract's requirements for Claims, and which the Contractor wishes to pursue in whole or in part. This Claim summary requirement shall not extend the time for submitting a Claim.

Failure to timely submit a Claim or Claim summary, failure to specifically identify a Claim in the Claim summary, or failure to comply with any of the requirements in the Contract for a Claim, including but not limited to this Article 4, will act as a complete waiver of Contractor's rights to (a) recover money or time on the issues for which a Claim was required, (b) submit a Government Code Claim for the money or time (see Section 4.5.6.4), and (c) initiate any action, proceeding or litigation for the money or time, regardless of the merits; Contractor will not have satisfied a condition precedent or exhausted administrative remedies. Owner does not have an obligation to reject the Claim for a failure to comply with any of the Claim requirements in the Contract, including the lack of certification, and any failure by Owner to reject, or any delay in rejecting, a Claim on that basis does not waive the Owner's right to reject the Claim on that basis at a later time. In no event may the Contractor reserve its rights to assert a Claim for a time extension or additional money beyond the timelines set forth in this provision unless the Owner agrees in writing to allow the reservation.

#### 4.5.5 CONTENT OF CLAIM

##### 4.5.5.1 *Claim Format; Waiver*

Every Claim shall be in writing. All money or time extensions sought must be stated and itemized in the Claim at the time submitted. The responsibility to substantiate Claims shall rest with the Contractor, and the Contractor shall furnish reasonable documentation to support each Claim, including as applicable, that documentation set forth in sections 4.5.5.2 through 4.5.5.4.

In addition, the Contractor shall include a certification with each and every Claim at the time of submission, as follows:

I, \_\_\_\_\_ [name of declarant], declare the following:

\_\_\_\_\_ [Contractor company name] has entered into a Contract with \_\_\_\_\_ [public entity name] on the \_\_\_\_\_ [name of project] Project. \_\_\_\_\_ [Contractor company name] authorized me to prepare the attached Claim for money and/or time extension) for \_\_\_\_\_ [public entity name] regarding \_\_\_\_\_ [Contractor company's name] Work on the Contract, and requesting \$ \_\_\_\_\_ and/or \_\_\_\_\_ additional days), and I prepared the attached Claim. I am the most knowledgeable person at \_\_\_\_\_ [Contractor company name] regarding this Claim.

The attached Claim complies with all laws applicable to submission of a Claim, including but not limited to California Penal Code section 72, Government Code sections 12650 et seq. (False Claims Act), and Business and Professions Code sections 17200 et seq. (Unfair Business Practices Act). I am aware that submission or certification of false claims, or other claims that violate law or the Contract, may lead to fines, imprisonment, and/or other serious legal consequences for myself or \_\_\_\_\_ [Contractor company name].

The attached Claim does not breach the Contract between \_\_\_\_\_ [Contractor company name] and \_\_\_\_\_ [public entity name] for this Project, is not a false claim, does not violate any applicable law, satisfies all provisions of the Contract applicable to submission of the Claim, only contains truthful and accurate supporting data, and only requests money and/or time extensions that accurately reflect the adjustments to money and time for which I believe that \_\_\_\_\_ [public entity name] is responsible under its Contract with \_\_\_\_\_ [Contractor company name].

While preparing this declaration and Claim, I consulted with others (including attorneys, consultants, or others who work for \_\_\_\_\_ [Contractor company name]) when necessary to ensure that the statements were true and correct.

Contractor understands and agrees that any Claim submitted without this certification does not meet the terms of the Contract Documents; that Owner, or Owner's representatives, may reject the Claim on that basis; and that unless Contractor properly and timely files the Claim with the certification, Contractor cannot further pursue the Claim in any forum and all rights to additional money or time for the issues covered by the Claim are waived due to a condition precedent not having been satisfied.

I declare under the penalty of perjury under the laws of the State of California that the foregoing is true and correct. Executed \_\_\_\_\_, 20\_\_\_\_, at \_\_\_\_\_, California.

\_\_\_\_\_  
\_\_\_\_\_ [name of declarant]

Contractor's failure to timely submit a certification will constitute a complete waiver of Contractor's rights to (a) recover money or time on the issues for which a Claim was required, (b) submit a Government Code Claim (see Section 4.5.6.3) for the money or time, and (c) initiate any action, proceeding or litigation for the money or time. Contractor will not have satisfied a condition precedent or exhausted administrative remedies.

#### ***4.5.5.2 Claims for Additional Money***

Each Claim for additional money (including but not limited to those described in (b) and (c) of the first paragraph of Section 4.5.3) must include all facts supporting the Claim, including but not limited to all supporting documentation plus a written analysis as to (a) why the claimed cost was incurred, (b) why Contractor could not mitigate its costs, (c) why the claimed cost is the responsibility of the Owner, and (d) why the claimed cost is a reasonable amount. In no event will the Contractor be allowed to reserve its rights, whether in a Claim or other document, to assert a Claim for money at a later time or in a manner other than as required by the Contract Documents. Any inclusion of a reservation of rights in a Claim shall be grounds for rejection of the Claim. Any costs not asserted shall be waived. A Claim may not include any costs incurred in preparation of the Claim or in preparation of any underlying COR, including but not limited to costs of delay analysis.

#### ***4.5.5.3 Claims for Additional Time***

##### ***4.5.5.3.1 Notice of Extent of Claim***

If the Contractor wishes to make a Claim for an increase in the Contract Time (including but not limited to Section 4.5.3(a)), the Claim shall include, but not be limited to, all facts supporting the Claim, all documentation of such facts, all information required by the Contract Documents, all information establishing entitlement to a time extension pursuant to Section 8.4.1 below, a current and certified schedule (see Section 3.9.1, above), and a delay analysis explaining (a) the nature of the delay, (b) the Owner's responsibility for the claimed delay, (c) the claimed delay's impact on the critical path, (d) the claimed delay's impact on the date of Completion (including an analysis of any float still remaining and whether the alleged delay in work exceeds such remaining float), and (e) why Contractor could not mitigate the delay impacts. Failure to include an updated and certified schedule, or a delay analysis, in a Claim seeking a time extension will act as a complete waiver of Contractor's rights to (i) recover money or time based on the issues addressed by the Claim, (ii) submit a Government Code Claim for the requested money or time (see Section 4.5.6.4), and (iii) initiate any action, proceeding or litigation for the requested money or time, regardless of the merits; Contractor will not have satisfied a condition precedent or exhausted administrative remedies.

In no event will the Contractor be allowed to reserve its rights, whether in a Claim or other document, to assert a Claim for a time extension at a later time or in a manner other than as required by the Contract Documents. Any inclusion of a reservation of rights in a Claim shall be grounds for rejection of the Claim. Any time extension not timely asserted in a certified Claim shall be waived.



#### 4.5.5.3.2 *Unusual and Uncommon Weather Claims*

If unusual and uncommon weather is the basis for a Claim for additional time, Contractor's delay analysis (see Section 4.5.5.3.1, above) must also provide Owner data and facts showing that the weather conditions were unusual and uncommon for the period of time, could not have been reasonably anticipated or mitigated, had an adverse effect on the critical path of the scheduled construction, and meet all other Contract requirements for a time extension (including but not limited to Section 8.4.1, below).

#### 4.5.5.4 *Subcontractor Requests for Money or Time*

A Subcontractor or supplier to Contractor may not submit a request for additional time or money directly to the Owner due to its lack of contractual privity with Owner. If a Subcontractor or supplier submits to Contractor a request for additional money or time based on an alleged breach of the subcontract or supplier contract by Contractor, Contractor may elect to seek money or time from Owner based on that request of the Subcontractor or supplier.

For any such request to Owner by Contractor, Contractor must comply with the requirements and prerequisites in the Contract Documents for requests to the Owner for money or time (including but not limited to Section 4.5 of the General Conditions regarding Notices of Potential Change, Change Order Requests ["CORs"], Claims, and certifications) and with Public Contract Code section 9204(d)(5). Any such COR or Claim by Contractor must include Contractor's certification (see General Conditions §§4.5.2 and 4.5.5.1), a complete copy of the Subcontractor's or supplier's request for money or time (including all documents submitted by the Subcontractor or supplier), and any other necessary supporting documentation. Any such COR or Claim by Contractor must also include (a) Contractor's detailed analysis of the merit of Subcontractor's or supplier's request to the Contractor, including (i) analysis of Contractor's alleged breaches of the subcontract or supplier contract that allegedly caused the Subcontractor or supplier to incur damages or delay, and (ii) analysis of all of Contractor's defenses to the request for money or time by the Subcontractor or supplier; and (b) Contractor's detailed analysis of the Owner's liability to Contractor for any money or time that Contractor owes, or may later be determined to owe, to Subcontractor or supplier (including but not limited to how Owner's alleged breaches of the Contract Documents caused Contractor to breach the subcontract or supplier contract). In any such COR or Claim, Contractor may deny that it is liable to the Subcontractor or supplier for some or all of the requested money or time, or it may assert that it is merely submitting the COR or Claim to Owner on behalf of the Subcontractor or supplier; but doing one or the other would not excuse Contractor from complying with the above requirements for its request to the Owner.

Any failure by Contractor to timely comply with this Section 4.5.5.4 (including a failure to timely submit a Notice of Potential Change, COR, Claim, certifications, or detailed analysis) shall act as a complete waiver of Contractor's rights to (a) recover money or time from Owner based on any money or time that Contractor owes, or may later be determined to owe, to the Subcontractor or supplier, (b) submit a Government Code Claim to Owner for the money or time requested by the Subcontractor or supplier (see Section 4.5.6.3), and (c) initiate any action, proceeding or litigation against Owner for any money or time that Contractor owes, or may later

be determined to owe, to the Subcontractor or supplier. Contractor will not have satisfied a condition precedent or exhausted administrative remedies.

#### **4.5.6 PROCEDURES FOR CLAIMS (PUBLIC CONTRACT CODE SECTION 9204)**

Claims are subject to this section 4.5.6, and Public Contract Code section 9204, as well as the separate procedures and substantive provisions of Sections 4.5.1 through 4.5.5 and the rest of the Contract Documents. Claims of \$375,000 or less, are also subject to Public Contract Code sections 20104 et seq., but to the extent that one of the procedures in Sections 20104 et seq. conflicts with the procedures in Section 9204, the requirements of Section 9204 shall control.

##### **4.5.6.1 *Claims***

The Owner shall conduct a reasonable review of the Claim and shall respond in writing to any written Claim within 45 days of receipt of the Claim. During that 45-day period, plus any extension, Owner may request in writing additional documentation supporting the Claim or relating to defenses to the Claim the Owner may have against the Contractor. Owner shall review any additional documentation Contractor supplies in response to that request within the 45 day, plus any extension, timeline.

After receipt of a Claim, the 45-day period may be extended by Owner and Contractor. The written response shall identify which portion of the Claim is disputed and what portion is undisputed. If Owner needs approval from its governing board to provide the written response, and the governing board does not meet within the 45 days or any extended period of time, then the Owner shall have up to three days after the next publicly noticed meeting of the governing board to provide the written response. Any payment due on an undisputed portion of the Claim shall be processed and made within sixty (60) days after the Owner issues the written response. Owner's failure to respond to a Claim within the above time periods or to otherwise meet the above time requirements shall result in the Claim being deemed rejected in its entirety.

##### **4.5.6.2 *Meet and Confer***

If the Contractor disputes the Owner's written response, or the Owner fails to respond within the time prescribed, the Contractor may so notify the Owner, in writing, either within 15 days of receipt of the Owner's response or within 15 days of the Owner's failure to respond within the time prescribed, respectively, and demand an informal conference to meet and confer for settlement of the issues in dispute. Upon a written demand sent by registered or certified mail return receipt requested, the Owner shall schedule a meet and confer conference for settlement of the dispute, which shall take place within 30 days of the demand. Upon written agreement of the Owner and Contractor, the conference may take place during regularly scheduled Project meetings. The informal conference is not a mediation since there is no neutral person facilitating communication to assist the parties to reach agreement; therefore, the provisions of Evidence Code sections 1115-1128 shall not apply to any portion of the informal conference (including but not limited to any documents provided or shown, or statements of fact or opinion made, by a party) unless the parties expressly agree in writing to their application. Any offer of compromise at an informal conference shall not be admissible to prove liability, as provided in Evidence

Code section 1152, but this statute's prohibition of admissibility shall not apply to other statements before or at the informal conference, or in any document prepared for or exchanged at the informal conference.

If Contractor fails to timely notify the Owner that it wishes to meet and confer pursuant to the previous paragraph, then Contractor will have waived all rights to (a) recover money or time on the issues for which a Claim was required, (b) submit a Government Code Claim (see Section 4.5.6) for such money or time, and (c) initiate any action, proceeding or litigation for such money or time. Contractor will not have satisfied a condition precedent or exhausted administrative remedies.

Within ten (10) business days after the conclusion of the meet and confer conference, the Owner shall give a written statement to the Contractor identifying the portion of the Claim that remains in dispute and the portion that is undisputed. Any payment due on an undisputed portion of the Claim shall be processed and made within sixty (60) days after the Owner issues the written statement. Within ten (10) business days of issuance of Owner's written statement, Contractor shall identify in writing the disputed portion of the Claim that shall be submitted to non-binding mediation (which may consist of any nonbinding process, including but not limited to neutral evaluation or a dispute review board), with the Owner and Contractor sharing the costs equally. The Owner and Contractor shall mutually agree to a mediator within ten (10) business days after the Contractor has identified in writing the disputed portion of the Claim. If they cannot agree upon a mediator, then each shall select a mediator and those two mediators shall select a qualified neutral third party to mediate the disputed portion of the Claim. (Each party shall bear the fees and costs its respective mediator charged in connection with the selection of the neutral mediator). The parties may mutually waive in writing the requirement for mediation. If Contractor fails to timely notify the Owner in writing that it wishes to mediate pursuant to this paragraph, Contractor will have waived all right to further pursue the Claim pursuant to section 4.5.4. The parties shall reasonably cooperate to schedule and attend a mediation as soon as reasonably possible. Owner's failure to respond to the Claim within the above time periods or to otherwise meet the above time requirements shall result in the Claim being deemed rejected in its entirety.

#### 4.5.6.3 *Government Code Claim*

If the Claim or any portion remains in dispute after the mediation and Contractor wishes to pursue it, the Contractor **must** file a timely and proper Government Code Claim. The filing of a Government Code Claim is specifically required in addition to all contractual procedures described in Sections 4.5 through 4.5.6.2. The above contractual procedures do not act as a substitute for the Government Code Claim process, and the two sets of procedures shall be sequential with the contractual procedures coming first.

Failure to timely file a Government Code Claim shall act as complete waiver of Contractor's rights to (a) recover money or time on the issues for which a Government Code Claim was required, and (b) initiate any action, proceeding or litigation for such money or time. Contractor will not have satisfied a condition precedent or exhausted administrative remedies.

Owner and Contractor shall proceed with the Government Code Claim according to Government Code, Section 900 et seq., and as otherwise permitted by law. For purposes of the applicable Government Code provisions, and as provided in Public Contract Code section 20104.2(e), the running of the time period within which a Contractor must file a Government Code Claim shall be tolled from the time the Contractor submits a written Claim under Article 4.5 until the time that the Claim is denied, in whole or in part, as a result of the meet and confer process in Section 4.5.6.2, including any period of time utilized by the meet and confer process.

#### **4.5.7 CONTINUING CONTRACT PERFORMANCE**

Despite Contractor's submission of, or Owner's rejection of, a Notice of Potential Change, COR or Claim, or Government Code Claim based on alleged breaches of the Contract by Owner, the Contractor shall proceed diligently with performance of the Contract as directed by Owner, and the Owner shall continue to make any undisputed payments in accordance with the Contract. Contractor acknowledges that Completion of the Work is a high priority for both Owner and Contractor as failure to Complete the Work would most likely cause each of them to incur much greater costs and damages than would be incurred if the Work were Completed. If Contractor believes that Owner has breached the Contract and that such breach is preventing or delaying Contractor's performance as directed by Owner, then Contractor must submit notice as required by Section 3.18, above.

#### **4.5.8 CLAIMS FOR CONCEALED OR UNKNOWN CONDITIONS**

##### ***4.5.8.1 Trenches or Excavations Less Than Four Feet Below the Surface***

If Contractor encounters conditions at the Site which are subsurface or otherwise concealed physical conditions, which differ materially from those indicated in the Contract Documents, or unknown physical conditions of an unusual nature, which differ materially from those ordinarily found to exist and generally recognized as inherent in construction activities of the character provided for in the Contract Documents, the Contractor shall give notice to the Owner promptly before conditions are disturbed and in no event later than ten (10) days after first observance of the conditions. If Contractor believes that such conditions differ materially and will cause an increase in the Contractor's cost of, time required for, or performance of any part of the Work, Contractor must comply with the provisions above for Notice of Potential Change, Change Order Request, and Claims (beginning with Section 4.5.1).

##### ***4.5.8.2 Trenches or Excavations Greater Than Four Feet Below the Surface***

Pursuant to Public Contract Code section 7104, when any excavation or trenching extends greater than four feet below the surface:

4.5.8.2.1 The Contractor shall promptly, and before the following conditions are disturbed, notify the public entity, in writing, of any:

(1) Material that the Contractor believes may be material that is hazardous waste, as defined in Section 25117 of the Health and Safety Code, that

is required to be removed to a Class I, Class II, or Class III disposal site in accordance with the provisions of existing law.

(2) Subsurface or latent physical conditions at the site differing from those indicated by information about the site made available to bidders prior to the deadline for submitting bids.

(3) Unknown physical conditions at the site of any unusual nature, different materially from those ordinarily encountered and generally recognized as inherent in work of the character provided for in the Contract.

4.5.8.2.2 The public entity shall promptly investigate the conditions, and if it finds that the conditions do materially so differ, or do involve hazardous waste, and cause a decrease or increase in the Contractor's cost of, or the time required for, performance of any part of the Work shall issue a change order under the procedures described in the Contract.

4.5.8.2.3 In the event that a dispute arises between the public entity and the Contractor whether the conditions materially differ, or involve hazardous waste, or cause a decrease or increase in the Contractor's cost of, or time required for, performance of any part of the Work, the Contractor shall not be excused from the Contract Completion deadline, but shall proceed with all Work to be performed under the Contract. The Contractor shall retain any and all rights provided either by Contract or by law which pertain to the resolution of disputes and protests between the contracting parties.

#### **4.5.9 INJURY OR DAMAGE TO PERSON OR PROPERTY**

If either party to the Contract suffers injury or damage to person or property because of an act or omission of the other party, any of the other party's employees or agents, or others for whose acts such party is legally liable, written notice of such injury or damage, whether or not insured, shall be given to the other party within a reasonable time not exceeding ten (10) days after first observance. The notice shall provide sufficient detail to enable the other party to investigate the matter. For a Notice of Potential Change, COR and Claim for additional cost or time related to this injury or damage, Contractor shall follow Section 4.5.

### **ARTICLE 5**

#### **SUBCONTRACTORS**

##### **5.1 DEFINITIONS**

###### **5.1.1 SUBCONTRACTOR**

A Subcontractor is a person or entity, who has a contract with the Contractor to perform a portion of the Work at the Site. The term "Subcontractor" is referred to throughout the Contract

Documents as if singular in number and means a Subcontractor or an authorized representative of the Subcontractor. The term “Subcontractor” does not include a separate contractor or subcontractors of a separate contractor. To the extent that the term Trade Contractor is utilized in the Contract Documents, it shall have the same meaning as the term “Subcontractor.”

#### **5.1.2 SUB-SUBCONTRACTOR**

A Sub-subcontractor is a person or entity who has a direct or indirect contract with a Subcontractor to perform a portion of the Work at the Site. The term “Sub-subcontractor” is referred to throughout the Contract Documents as if singular in number and means a Sub-subcontractor or an authorized representative of the Sub-subcontractor.

#### **5.1.3 SPECIALTY CONTRACTORS**

If a Subcontractor is designated as a “Specialty Contractor” as defined in section 7058 of the Business and Professions Code, all of the Work outside of that Subcontractor’s specialty shall be performed in compliance with the Subletting and Subcontracting Fair Practices Act, Public Contract Code sections 4100, et seq.

### **5.2 AWARD OF SUBCONTRACTS AND OTHER CONTRACTS FOR PORTIONS OF THE WORK**

#### **5.2.1 ASSIGNMENT OR SUBSTITUTION - CONSENT OF OWNER**

In accordance with Public Contract Code sections 4107 and 4107.5, no Contractor whose bid is accepted shall, without the written consent of the Owner: substitute any person or entity as a Subcontractor in place of the Subcontractor designated in the original bid; permit any such Subcontract to be assigned or transferred, or allow it to be performed by any person or entity other than the original Subcontractor listed in the original bid; sublet or subcontract any portion of the Work in excess of one-half of one percent (0.5%) of the Contractor’s total bid as to which its original bid did not designate a Subcontractor. Any assignment or substitution made without the prior written consent of the awarding authority shall be void, and the assignees shall acquire no rights in the Contract. Any consent, if given, shall not relieve Contractor or its Subcontractors from their obligations under the terms of the Contract Documents.

#### **5.2.2 GROUNDS FOR SUBSTITUTION**

Pursuant to Public Contract Code section 4107 and the procedure set forth therein, no Contractor whose bid is accepted may request to substitute any person or entity as a Subcontractor in place of a Subcontractor listed in the original bid except in the following instances:

- A. When the Subcontractor listed in the bid after having a reasonable opportunity to do so, fails or refuses to execute a written contract for the scope of work specified in the subcontractor’s bid and at the price specified in the subcontractor’s bid, when that written contract, based upon the general terms, conditions, plans and

specifications for the Project involved or the terms of that Subcontractor's written bid, is presented to the Subcontractor by the Contractor;

- B. When the listed Subcontractor becomes insolvent or the subject of an order for relief in bankruptcy;
- C. When the listed Subcontractor fails or refuses to perform his or her Subcontract;
- D. When the listed Subcontractor fails or refuses to meet the bond requirements of the prime contractor set forth in Public Contract Code section 4108.
- E. When the Contractor demonstrates to the awarding authority, or its duly authorized officer, subject to the further provisions of Public Contract Code section 4107.5, that the name of the Subcontractor was listed as the result of inadvertent clerical error;
- F. When the listed Subcontractor is not licensed pursuant to the Contractors License Law; or
- G. When the awarding authority, or its duly authorized officer, determines that the Work being performed by the listed Subcontractor is substantially unsatisfactory and not in substantial accordance with the plans and specifications, or the Subcontractor is substantially delaying or disrupting the progress of the Work.
- H. When the listed Subcontractor is ineligible to work on a public works project pursuant to Section 1777.1 of the Labor Code.
- I. When the awarding authority determines that a listed Subcontractor is not a responsible contractor.

5.2.2.1 **No Change in Contract.** Any substitutions of Subcontractors shall not result in any increase in the Contract Sum or result in the granting of any extension of time for Completion of the Work.

5.2.2.2 **Substitution Due to Clerical Error.** The Contractor, as a condition of asserting a claim of inadvertent clerical error in the listing of a Subcontractor, shall, pursuant to Public Contract Code section 4107.5, within two (2) working days after the time of the prime bid opening by the awarding authority, give written notice to the awarding authority and copies of such notice to both the Subcontractor it claims to have listed in error, and the intended Subcontractor who had bid to the Contractor prior to bid opening. Any listed Subcontractor who has been notified by the Contractor in accordance with the provisions of this section as to an inadvertent clerical error, shall be allowed six (6) working days from the time of the prime bid opening within which to submit to the awarding authority and to the Contractor written objection to the Contractor's claim of inadvertent clerical error.

In all other cases, the Contractor must make a request in writing to the awarding authority for the substitution of a subcontractor, giving reasons therefor. The awarding authority shall mail a written notice to the listed Subcontractor giving reasons for the proposed substitution. The listed Subcontractor shall have five (5) working days from the date of such notice within which to file with the awarding authority written objections to the substitution.

Failure to file written objections pursuant to the provisions of this section within the times specified herein shall constitute a complete waiver of objection to the substitution by the listed Subcontractor and, where the ground for substitution is an inadvertent clerical error, an agreement by the listed Subcontractor that an inadvertent clerical error was made.

If written objections are filed, the awarding authority shall give five (5) days notice to the Contractor and to the listed Subcontractor of a hearing by the awarding authority on the Contractor's request for substitution as provided in Public Contract Code section 4107. The determination by the awarding authority shall be final.

### **5.3 SUBCONTRACTUAL RELATIONS**

By appropriate agreement, written where legally required for validity, the Contractor shall require each Subcontractor, to the extent of the Work to be performed by the Subcontractor, to be bound to the Contractor by terms of the Contract Documents, and to assume toward the Contractor all obligations and responsibilities, which the Contractor, by the Contract Documents, assumes toward the Owner. Each subcontract agreement shall preserve and protect the rights of the Owner under the Contract Documents with respect to the Work to be performed by the Subcontractor so that subcontracting thereof will not prejudice such rights, and shall allow to the Subcontractor, unless specifically provided otherwise in the subcontract agreement, the benefit of all rights, remedies, and redress against the Contractor that the Contractor, by the Contract Documents, has against the Owner. Where appropriate, the Contractor shall require each Subcontractor to enter into similar agreements with Sub-subcontractors. The Contractor shall make available to each proposed Subcontractor, prior to the execution of the subcontract agreement, copies of the Contract Documents to which the Subcontractor will be bound. Upon written request of the Subcontractor, the Contractor shall identify to the Subcontractor the terms and conditions of the proposed subcontract agreement, which may be at variance with the Contract Documents. Subcontractors shall similarly make copies of applicable portions of such documents available to their respective proposed Sub-subcontractors.

### **5.4 CONTINGENT ASSIGNMENT OF SUBCONTRACTS**

Each subcontract agreement for a portion of the Work is assigned by the Contractor to the Owner provided that:

- A. Assignment is effective only after termination of the Contract with the Contractor by the Owner for cause pursuant to Article 14 and only for those subcontract agreements which the Owner accepts by notifying the Subcontractor in writing; and



- B. Assignment is subject to the prior rights of the surety, if any, obligated under any bond relating to the Contract.

## **5.5 SUBCONTRACTOR'S RESPONSIBILITIES**

Every Subcontractor is bound to the following provisions, unless specifically noted to the contrary in the Subcontractor's contract subject to the limitations of section 5.3.

### **5.5.1 SUPERVISION BY SUBCONTRACTORS**

Subcontractors shall efficiently supervise their Work, using their best skill and attention. Each of them shall carefully study and compare all Drawings, Specifications, and other instructions, shall at once report to Contractor any error or omission which any of them may discover, and shall subsequently proceed with the Work in accordance with instructions from the Contractor concerning such error or omission. Each Subcontractor shall be fully responsible for and shall bear the full risk of loss of all of its property.

### **5.5.2 DISCIPLINE AND ORDER**

Each Subcontractor shall at all times enforce strict discipline and good order among its Subcontractors, material or equipment suppliers, or their agents, employees, and invitees, and shall establish and maintain surveillance over the activities of each of the foregoing to minimize any disturbance, damage, pollution, or unsightly conditions relative to property areas adjacent to or in the vicinity of the Site. The Contractor shall have the right to remove from the Work any employee of a Subcontractor for any reason including, without limitation, incompetence or carelessness.

### **5.5.3 DEFECTS DISCOVERED**

Should the proper and accurate performance of the Work depend upon the proper and accurate performance of other work not included in its Contract, each Subcontractor shall use all necessary means to discover any defect in such other work and shall allow the Contractor, the Owner and Architect, or other Subcontractors as Contractor elects, a reasonable amount of time to remedy such defects. If the Subcontractor should proceed with its Work, it shall be considered to have accepted such other work, unless the Subcontractor shall have proceeded pursuant to instructions in writing by the Contractor over its written objection.

### **5.5.4 SUBCONTRACTOR INFORMATION**

Each Subcontractor shall submit to the Owner, the Contractor, or the Architect, as the case may be, promptly when requested by any of the foregoing, information with respect to the names, responsibilities, and titles of the principal members of its staff, the adequacy of the Subcontractor's equipment and the availability of necessary materials and supplies. Subcontractor shall fully cooperate with Contractor in its periodic review of the adequacy of Subcontractor's supervision, personnel, and equipment, and the availability of necessary materials and supplies and shall promptly comply with the requirements of the Contractor with

respect thereto.

#### **5.5.5 TEMPORARY STRUCTURES**

Each Subcontractor shall furnish at its expense its own temporary facilities and storage except those specifically agreed to be furnished to it by the Contractor in the Subcontract Agreement. Subcontractor's material storage rooms and field offices, etc., will be placed in locations designated by the Contractor. When it becomes necessary due to the progress of the Work for the Subcontractor to relocate its field operations, it will do so in an expeditious manner and at no additional cost to Contractor or Owner. The construction of material storage rooms and field offices, etc., will be of fire resistive material only, such as concrete or gypsum block, rated drywall, or sheet metal.

#### **5.5.6 CHARGES TO SUBCONTRACTOR**

Each Subcontractor may be subject to the Contractor's reasonable charges for hoisting, repair to other work caused by the fault or negligence of Subcontractor, removal of Subcontractor's rubbish, and clean-up occasioned by Subcontractor.

#### **5.5.7 FINES IMPOSED**

Subcontractor shall comply with and pay any fines or penalties imposed for violation of any applicable law, ordinance, rule, regulation, Environmental Impact Report mitigation requirement, and lawful order of any public authority, including, without limitation, all OSHA and California OSHA requirements and those of other authorities having jurisdiction of the safety of persons or property.

#### **5.5.8 PROJECT SIGNS**

Each Subcontractor shall not display on or about the Project any sign, trademark, or other advertisement. The Owner will permit a single Project sign, which shall be subject to the Owner's prior and sole discretion and approval, as to all matters including, without limitation, size, location, material, colors, style and size of printing, logos and trademarks (if any), text, and selection of names to be displayed.

#### **5.5.9 REMEDIES FOR FAILURE TO PERFORM**

Without limitation of any other right or remedy available to Contractor under the Contract Documents or at law, should: the Subcontractor fail to perform its portion of the Work in a skilled and expeditious manner in accordance with the terms of the Contract Documents with sufficient labor, materials, equipment, and facilities; delays the progress of the job or otherwise fail in any of its obligations; or either a receiver is appointed for the Subcontractor or the Subcontractor is declared to be bankrupt or insolvent, and such appointment, bankruptcy, or insolvency proceedings or declaration is not set aside within thirty (30) days, then the Contractor, upon three (3) days notice to the Subcontractor (subject to the requirements of Pub. Contracts Code, § 4107), may provide such labor, materials, or perform such work and recover the cost

plus profit and overhead from monies due or to become due thereafter to the Subcontractor. The Contractor may terminate the employment of the Subcontractor, taking possession of its tools, materials, and equipment related to the Work and cause the entire portion of the Subcontractor's Work to be finished either by another Subcontractor or through the Contractor's own forces.

#### **5.5.10 DISPUTES NOT TO AFFECT WORK**

In the event of any dispute as to whether or not any portion of the Work is within the scope of the Work to be performed by a Subcontractor, or any dispute as to whether or not the Subcontractor is entitled to a Change Order for any Work requested of it or entitled to payment, the Subcontractor shall continue to proceed diligently with the performance of the Work. Regardless of the size or nature of the dispute, the Subcontractor shall not under any circumstances cease or delay performance of its portion of the Work during the existence of the dispute. The Contractor shall continue to pay the undisputed amounts called for under the Subcontract Agreement during the existence of the dispute. Any party stopping or delaying the progress of the Work because of a dispute shall be responsible in damages to the Owner, the Architect, and the Contractor for any losses suffered as a result of the delay.

#### **5.5.11 APPLICATION FOR PAYMENT**

Contractor agrees to advise the Subcontractor if any documentation in connection with the Subcontractor's application for payment has not been accepted or is in any way unsatisfactory.

#### **5.5.12 COMPLIANCE WITH PROCEDURES**

Each Subcontractor shall comply with all procedures established by the Contractor for coordination among the Owner, the Owner's consultants, Architect, Contractor, and the various Subcontractors for coordination of the Work with all local municipal authorities, government agencies, utility companies, and any other agencies with jurisdiction over all or any portion of the Work. The Subcontractor shall cooperate fully with all of the foregoing parties and authorities.

#### **5.5.13 ON-SITE RECORD KEEPING**

Subcontractor shall comply with all on-Site record keeping systems established by the Contractor and shall, upon the request of the Contractor, provide the Contractor with such information and reports as the Contractor may deem appropriate. Without limitation of the foregoing, the Subcontractor shall assemble all required permits and certificates so that they are readily accessible at the Site.

#### **5.5.14 NON-EXCLUSIVE OBLIGATIONS**

The specific requirements of Article 5 are not intended to exclude the obligation of the Subcontractor to comply with any of the other provisions of the General Conditions and the other

Contract Documents which are relevant to the proper performance of its portion of the Work.

## **ARTICLE 6**

### **CONSTRUCTION BY OWNER OR BY SEPARATE CONTRACTORS**

#### **6.1 OWNER'S RIGHT TO PERFORM CONSTRUCTION AND TO AWARD SEPARATE CONTRACTS**

##### **6.1.1 OWNER'S RIGHTS**

The Owner reserves the right to perform Project work with the Owner's own forces, or to award separate contracts in connection with such other work or other construction or operations on the Site under contract conditions identical or substantially similar to these including those portions related to insurance. Upon the election to perform such work with its own forces or by separate contracts, the Owner shall notify the Contractor. If the Contractor claims that delay or additional cost is involved because of such action by the Owner, the Contractor shall proceed pursuant to Section 4.5 in the Contract Documents.

##### **6.1.2 DESIGNATION AS CONTRACTOR**

When separate contracts are awarded for different portions of the Project or other construction or operations on the Site, the term "Contractor" in the Contract Documents in each of those contracts shall mean the contractor who executes each separate Owner/Contractor agreement.

##### **6.1.3 CONTRACTOR DUTIES**

Although the Owner shall have overall responsibility for coordination and scheduling of the activities of the Owner's own forces and of each separate contractor with the Work of the Contractor, Contractor shall cooperate with Owner. The Contractor shall participate with other separate contractors and the Owner in reviewing their construction schedules when directed to do so. The Contractor shall make any revisions to the construction schedule deemed necessary after a joint review and mutual agreement. The construction schedules shall then constitute the schedules to be used by the Contractor until subsequently revised.

##### **6.1.4 OWNER OBLIGATIONS**

Unless otherwise provided in the Contract Documents, when the Owner performs work related to the Project with the Owner's own forces, the Owner shall be deemed to be subject to the same obligations, and to have the same rights, which apply to the Contractor under the General Conditions, including, without excluding others, those stated in Article 3, this Article 6 and Articles 10 and 12.

## **6.2 MUTUAL RESPONSIBILITY**

### **6.2.1 DELIVERY AND STORAGE**

The Contractor shall afford the Owner and separate contractors reasonable opportunity for delivery and storage of their materials and equipment and performance of their activities, and shall connect and coordinate the separate contractors' construction and operations with theirs as required by the Contract Documents.

### **6.2.2 NOTICE BY CONTRACTOR**

If part of the Contractor's Work depends upon proper execution or results from work by the Owner or a separate contractor, the Contractor shall, prior to proceeding with that portion of the Work, promptly report to the Owner patent discrepancies or defects in such other construction that would render it unsuitable for such proper execution and results. Failure of the Contractor to so report shall constitute an acknowledgment that the Owner's or separate contractors' completed or partially completed construction is fit and proper to receive the Contractor's Work, except as to defects not then reasonably discoverable.

### **6.2.3 COSTS INCURRED**

Costs, expenses, and damages caused by delays, improperly timed activities, defective construction, or damages to another's work/Work or property shall be borne by the party responsible. Should Contractor cause damage to the work or property of any other contractor on the Project, or to the Project or property of a third party, or cause any delay to any such contractor or third party, the Contractor shall defend, indemnify and hold Owner harmless for such damage or delay under Section 3.16, above. Owner may withhold from progress payments and/or retention the cost of delay or damage to another contractor's work or damage to another contractor's property or to the property of Owner caused by Contractor.

### **6.2.4 CORRECTION OF DAMAGE**

The Contractor shall promptly remedy damage wrongfully caused by the Contractor to completed or partially completed construction or to property of the Owner or separate contractors.

## **6.3 OWNER'S RIGHT TO CLEAN UP**

If a dispute arises among the Contractor, separate contractors, and the Owner as to the responsibility under their respective contracts for maintaining the premises and surrounding area free from waste materials and rubbish as described in Section 3.13, the Owner may clean up and allocate the cost among those responsible as the Owner determines to be just.

## **ARTICLE 7**

### **CHANGES IN THE WORK**

#### **7.1 CHANGES**

##### **7.1.1 NO CHANGES WITHOUT AUTHORIZATION**

The Owner reserves the right to change the Work by making such alterations, deviations, additions to, or deletions from the plans and specifications, as may be deemed by the Owner to be necessary or advisable for the proper Completion or construction of the Work contemplated, and Owner reserves the right to require Contractor to perform such work. No adjustment will be made in the Contract unit price of any Contract item regardless of the quantity ultimately required.

Owner shall compensate Contractor with money or grant extra time for any extra work ordered by the Owner to be performed. Contractor shall follow the provisions of the Contract Documents, including General Conditions sections 4.5, 7.6, 7.7, and 8.4, when requesting additional money or additional time. Contractor shall expeditiously perform all extra work upon direction, even if no agreement has been reached on extra time or money. For all such changes resulting in a credit to Owner, Contractor shall follow Sections 7.5 and 7.7 in providing the credit to Owner. Contractor shall bring all potential credits to the Owner's attention.

There shall be no change whatsoever in the drawings, specifications, or in the Work or payments under the Contract Documents without an executed Change Order, Construction Change Directive, or order by the Owner pursuant to Section 7.1.2. Owner shall not be liable for the cost of any extra work or any substitutions, changes, additions, omissions, or deviations from the Drawings and Specifications unless the same shall have been properly requested under Section 4.5 and authorized by, and the cost thereof approved in writing by, Change Order or Construction Change Directive. Owner shall not be liable for, and Contractor shall bear the burden of, any post-bid escalation in the costs of materials; but Contractor will retain the benefit of any post-bid cost decreases. No extension of time for performance of the Work shall be allowed hereunder unless request for such extension is properly made under Section 4.5 and such time is thereof approved in writing by Change Order or Construction Change Directive. The provisions of the Contract Documents shall apply to all such changes, additions, and omissions with the same effect as if originally embodied in the Drawings and Specifications.

##### **7.1.2 AUTHORITY TO ORDER MINOR CHANGES**

The Owner has authority to order minor changes in the Work not involving any adjustment in the Contract Sum, an extension of the Contract Time, or a change which is inconsistent with the intent of the Contract Documents. Such changes shall be effected by written Construction Change Directive and shall be binding on the Contractor. The Contractor shall carry out such written orders promptly.

## 7.2 CHANGE ORDERS (“CO”)

A CO is a written instrument signed by the Owner and the Contractor, stamped (or sealed) and signed by Architect, and approved by the Owner’s Governing Board and DSA, stating the agreement of Owner and Contractor upon all of the following:

- A. A change in the Work;
- B. The amount of the adjustment in the Contract Sum, if any; and
- C. The extent of the adjustment in the Contract Time, if any.

Unless expressly stated otherwise in the CO, any CO executed by Owner and Contractor constitutes and includes full and complete money and time (including but not limited to, adjustments to money and time) for all costs and effects caused by any of the changes described within it. Unless expressly stated otherwise in the CO, in consideration for the money received for the changes described in the CO, Contractor waives all Claims for all costs and effects caused by any of the changes, including but not limited to labor, equipment, materials, delay, extra work, overhead (home and field), profit, direct costs, acceleration, disruption, impaired productivity, time extensions, and any the costs and effects on Subcontractors and suppliers of any tier.

## 7.3 CONSTRUCTION CHANGE DIRECTIVES (“CCD”)

### 7.3.1 DEFINITION

A CCD is a written unilateral order signed by the Owner directing performance of the Work or a change in the Work. The CCD may state an adjustment in the Contract Sum, Contract Time, or Milestone Deadline. The Owner may by CCD, without invalidating the Contract, order changes in the Work within the general scope of the Contract consisting of additions, deletions, or other revisions pursuant to Section 7.1.1.

### 7.3.2 USE TO DIRECT CHANGE

A CCD shall be used in the absence of agreement on the terms of a CO. If Contractor disagrees with the terms of a CCD, it shall nevertheless perform the work directed by the CCD, but it may pursue the Notice of Potential Change, COR and Claim procedures of Section 4.5 if Contractor believes it is entitled to changes in the Contract Sum or Contract Time.

## 7.4 REQUEST FOR INFORMATION (“RFI”)

### 7.4.1 DEFINITION

An RFI is a written request prepared by the Contractor asking the Owner to provide additional information necessary to clarify an item which the Contractor feels is not clearly shown or called for in the drawings or specifications, or to address problems which have arisen under field

conditions.

#### **7.4.2 SCOPE**

The RFI shall reference all the applicable Contract Documents including specification section, detail, page numbers, drawing numbers, and sheet numbers, etc. The Contractor shall make suggestions and/or interpretations of the issue raised by the RFI. An RFI cannot modify the Contract Sum, Contract Time, or the Contract Documents.

#### **7.4.3 RESPONSE TIME**

Unless Owner expressly directs otherwise in writing, Contractor shall submit RFIs directly to the Architect, with copies forwarded to the Owner. Contractor shall submit a revised and updated priority schedule with each RFI. The Architect shall endeavor to follow the Contractor's requested order of priorities. The Owner and Contractor agree that an adequate time period for the Architect (or other designated recipient of the RFI) to respond to an RFI is generally fourteen (14) calendar days after the Architect's receipt of an RFI, unless the Owner and Contractor agree otherwise in writing. However, in all cases, the Architect shall take such time, whether more or less than 14 days, as is necessary in the Architect's professional judgment to permit adequate review and evaluation of the RFI. If Contractor informs the Architect that it needs a response to an RFI expedited to avoid delay to the critical path, the Architect shall provide a response as quickly as reasonably possible. The total time required for the Architect to respond is subject to the complexity of the RFI, the number of RFI's submitted concurrently and the reprioritization of pending RFI's submitted by the Contractor, among other things. If Contractor believes that the Architect's response results in a change in the Work that warrants additional money or time, or that Architect's response was unreasonably delayed and caused delay to the Work's critical path, Contractor shall follow the procedures for additional money or time under Section 4.5. No presumption shall arise as to the timeliness of the response if the response is more than fourteen (14) days after the Architect's receipt of the RFI. Contractor shall review the Contract Documents before submitting an RFI to ensure that the information is not already in the Contract Documents. To compensate the Owner for time and costs incurred for each time the information was already in the Contract Documents, Owner may withhold \$100 from progress payments or retention in addition to any other remedies which Owner may have the right to pursue.

#### **7.4.4 COSTS INCURRED**

The Contractor shall be invoiced by the Owner for any costs incurred for professional services, which shall be withheld from progress payments or retention, if an RFI requests an interpretation or decision of a matter where the information sought is equally available to the party making such request.

### **7.5 REQUEST FOR PROPOSAL ("RFP")**

#### **7.5.1 DEFINITION**

An RFP is Owner's written request asking the Contractor to submit to the Owner an estimate of



the effect, including credits, of a proposed change on the Contract Sum and the Contract Time.

#### **7.5.2 SCOPE**

An RFP shall contain adequate information, including any necessary drawings and specifications, to enable Contractor to provide the cost breakdowns required by section 7.7. The Contractor shall not be entitled to any additional money for preparing a response to an RFP, whether ultimately accepted or not.

### **7.6 CHANGE ORDER REQUEST (“COR”)**

#### **7.6.1 DEFINITION**

A COR is any written request prepared by the Contractor asking the Owner for additional money or time, including a “proposed change order” or “PCO.” However, a Claim (see Sections 4.5.3-4.5.6) is not a COR. See Section 4.5.2 for additional COR requirements. The COR shall include all information necessary to establish the Contractor’s entitlement to additional money or time.

#### **7.6.2 CHANGES IN PRICE**

A COR shall include breakdowns per section 7.7 to validate any proposed change in Contract Sum.

#### **7.6.3 CHANGES IN TIME**

Where a change in a Milestone Deadline or Contract Time is requested, a COR shall also include delay analysis to validate any proposed change, and shall meet all requirements in these General Conditions, including but not limited to Section 8.4. Any additional time requested shall not be the number of days to make the proposed change, but must be based upon the impact to the Work schedule as defined in section 3.9 and Division 1 of the Specifications.

### **7.7 PRICE OF CHANGE ORDERS**

#### **7.7.1 SCOPE**

Any COR shall provide in writing to the Owner, the Architect and any construction manager, the effect of the proposed CO upon the Contract Sum and the actual cost of construction, which shall include a complete itemized cost breakdown of all labor and material showing actual quantities, hours, unit prices, wage rates, required for the change, and the effect upon the Contract Time of such CO.

#### **7.7.2 DETERMINATION OF COST**

The amount of the increase or decrease in the Contract Sum resulting from a CO, if any, shall be determined in one or more of the following ways as applicable to a specific situation:

- A. Mutual acceptance of a lump sum properly itemized and supported by sufficient substantiating data to permit evaluation;
- B. Unit prices stated in the Contractor's original bid, the Contract Documents, or subsequently agreed upon between the Owner and the Contractor;
- C. Cost to be determined in a manner agreed upon by the parties and a mutually acceptable fixed or percentage fee; or
- D. By cost of material and labor and percentage of overhead and profit. If the value is determined by this method the following requirements shall apply:

1. **Daily Reports by Contractor.**

a) General: At the close of each working day, the Contractor shall submit a daily report to the Inspector of Record and any construction manager, on forms approved by the Owner, together with applicable delivery tickets, listing all labor, materials, and equipment involved for that day, the location of the work, and for other services and expenditures when authorized concerning extra work items. An attempt shall be made to reconcile the report daily, and it shall be signed by the Inspector of Record and the Contractor. In the event of disagreement, pertinent notes shall be entered by each party to explain points which cannot be resolved immediately. Each party shall retain a signed copy of the report. Reports by Subcontractors or others shall be submitted through the Contractor.

b) Labor: Show names of workers, classifications, and hours worked.

c) Materials: Describe and list quantities of materials used.

d) Equipment: Show type of equipment, size, identification number, and hours of operation, including, if applicable, loading and transportation.

e) Other Services and Expenditures: Describe in such detail as the Owner may require.

2. **Basis for Establishing Costs.**

a) Labor will be the actual cost for wages prevailing locally for each craft or type of workers at the time the extra work is done, plus employer payments of payroll taxes and insurance, health and welfare, pension, vacation, apprenticeship funds, and other direct costs resulting from Federal, State, or local laws, as well as assessments or benefits required by lawful collective bargaining agreements. The use of a labor classification, which would increase the extra work cost, will not be permitted unless the Contractor establishes the necessity for such additional costs. Labor costs for equipment operators and

helpers shall be reported only when such costs are not included in the invoice for equipment rental.

b) Materials shall be at invoice or lowest current price at which such materials are locally available and delivered to the Site in the quantities involved, plus sales tax, freight, and delivery.

The Owner reserves the right to approve materials and sources of supply or to supply materials to the Contractor if necessary for the progress of the Work. No markup shall be applied to any material provided by the Owner.

c) Tool and Equipment Rental. No payment will be made for the use of tools which have a replacement value of \$100 or less.

Regardless of ownership, the rates to be used in determining equipment rental costs shall not exceed listed rates prevailing locally at equipment rental agencies or distributors at the time the work is performed.

The rental rates paid shall include the cost of fuel, oil, lubrication, supplies, small tools, necessary attachments, repairs and maintenance of any kind, depreciation, storage, insurance, and all incidentals.

Necessary loading and transportation costs for equipment used on the extra work shall be included. If equipment is used intermittently and, when not in use, could be returned to its rental source at less expense to the Owner than holding it at the work Site, it shall be returned unless the Contractor elects to keep it at the work Site at no expense to the Owner.

All equipment shall be acceptable to the Inspector of Record, in good working condition, and suitable for the purpose for which it is to be used. Manufacturer's ratings and modifications shall be used to classify equipment, and equipment shall be powered by a unit of at least the minimum rating recommended by the manufacturer.

d) Other Items. The Owner may authorize other items which may be required on the extra work. Such items include labor, services, material, and equipment which are different in their nature from those required by the Work, and which are of a type not ordinarily available from the Contractor or any of the Subcontractors. Invoices covering all such items in detail shall be submitted with the Application for Payment.

e) Invoices. Vendors' invoices for material, equipment rental, and other expenditures shall be submitted with the COR. If the Application for Payment is not substantiated by invoices or other documentation, the Owner may establish the cost of the item involved at the lowest price which was current at the time of the Daily Report.

f) Overhead, premiums and profit. For overhead, including direct costs, submit with the COR and include: home office overhead, off-Site supervision, CO preparation/negotiation/research for Owner initiated changes, time delays, project interference and disruption, additional guaranty and warranty durations, on-Site supervision, additional temporary protection, additional temporary utilities, additional material handling costs, and additional safety equipment costs.

**7.7.3 FORMAT FOR PROPOSED COST CHANGE**

The following format shall be used as applicable by the Owner and the Contractor to communicate proposed additions and deductions to the Contract.

	<u>EXTRA</u>	<u>CREDIT</u>
A. Material (attach itemized quantity and unit cost plus sales tax, invoices, receipts, truck tags, etc., for force account work)	_____	_____
B. Labor (attach itemized hours and rates, daily logs, certified payroll, etc.)	_____	_____
C. Equipment (attach any invoices)	_____	_____
D. Subtotal	_____	_____
E. If Subcontractor performed Work, add Subcontractor's overhead and profit to portions performed by Subcontractor, not to exceed fifteen percent (15%) of item D.	_____	_____
F. Liability and Property Damage Insurance, Worker's Compensation Insurance, Social Security, and Unemployment Taxes, not to exceed twenty-five percent (25%) of Item B.	_____	_____
G. Subtotal	_____	_____
H. General Contractor's Overhead and Profit, not to exceed fifteen percent (15%) of Item G; and for work performed by subcontractors, not to exceed five percent (5%).	_____	_____

I.	Subtotal	_____	_____
J.	Bond not to exceed one percent (1%) of Item I.	_____	_____
K.	TOTAL	_____	_____

It is expressly understood that the value of such extra work or changes, as determined by any of the aforementioned methods, expressly includes (1) any and all of the Contractor’s costs and expenses resulting from additional time required on the project or resulting from delay to the project, and (2) any costs of preparing a COR, including but not limited to delay analysis. Any costs or expenses not included are deemed waived.

**7.7.4 DISCOUNTS, REBATES, AND REFUNDS**

For purposes of determining the cost, if any, of any change, addition, or omission to the Work hereunder, all trade discounts, rebates, refunds, and all returns from the sale of surplus materials and equipment shall accrue and be credited to the Contractor, and the Contractor shall make provisions so that such discounts, rebates, refunds, and returns may be secured, and the amount thereof shall be allowed as a reduction of the Contractor’s cost in determining the actual cost of construction for purposes of any change, addition, or omissions in the Work as provided herein.

**7.7.5 ACCOUNTING RECORDS**

With respect to portions of the Work performed by COs and CCDs on a time-and-materials, unit-cost, or similar basis, the Contractor shall keep and maintain cost-accounting records satisfactory to the Owner, which shall be available to the Owner on the same terms as any other books and records the Contractor is required to maintain under the Contract Documents.

**7.7.6 NOTICE REQUIRED**

Contractor shall submit a written Notice of Potential Change for additional money or time pursuant to section 4.5.1.

**7.7.7 APPLICABILITY TO SUBCONTRACTORS**

Any requirements under this Article 7 shall be equally applicable to COs or CCDs issued to Subcontractors by the Contractor to the same extent required of the Contractor.

**7.8 WAIVER OF RIGHT TO CLAIM MONEY OR TIME**

Failure to demand money based on costs, or time extensions, as part of a COR constitutes a complete waiver of Contractor’s right to claim the omitted money or time. All money or time for an issue must be included in the COR at the time submitted.

## **ARTICLE 8**

### **TIME**

#### **8.1 DEFINITIONS**

##### **8.1.1 CONTRACT TIME**

Unless otherwise provided, Contract Time is the period of time, including authorized adjustments, allotted in the Contract Documents for Completion of the Work.

##### **8.1.2 NOTICE TO PROCEED**

Contractor shall not commence the Work until it receives a Notice to Proceed from Owner. The date of commencement of the Work is the date established in the Notice to Proceed. The date of commencement shall not be postponed by the failure to act of the Contractor or of persons or entities for whom the Contractor is responsible.

##### **8.1.3 DAYS**

The term “day” as used in the Contract Documents shall mean calendar day unless otherwise specifically defined.

#### **8.2 HOURS OF WORK**

##### **8.2.1 SUFFICIENT FORCES**

Contractors and Subcontractors shall furnish sufficient forces to ensure the prosecution of the Work, including Work directed pursuant to a CCD (see Section 7.3, above), in accordance with the Construction Schedule.

##### **8.2.2 PERFORMANCE DURING WORKING HOURS**

Work shall be performed during regular working hours except that in the event of an emergency or when required to complete the Work in accordance with job progress, work may be performed outside of regular working hours with the advance written consent of the Owner.

##### **8.2.3 LABOR CODE APPLICATION**

As provided in Article 3 (commencing at § 1810), Chapter 1, Part 7, Division 2 of the Labor Code, eight (8) hours of labor shall constitute a legal day’s work. The time of service of any worker employed at any time by the Contractor or by any Subcontractor on any subcontract under this Contract, upon the work or upon any part of the work contemplated by this Contract, is limited and restricted to eight (8) hours during any one calendar day and forty (40) hours during any one calendar week, except as hereinafter provided. Notwithstanding the provision hereinabove set forth, work performed by employees of Contractors in excess of eight (8) hours

per day and forty (40) hours during any one week shall be permitted upon this public work with compensation provided for all hours worked in excess of eight (8) hours per day at not less than one and one-half (1-1/2) times the basic rate of pay.

Contractor or subcontractor shall pay to the Owner a penalty of Twenty-five Dollars (\$25.00) for each worker employed in the execution of this Contract by the Contractor, or by any Subcontractor, for each calendar day during which such worker is required or permitted to work more than eight (8) hours in any calendar day and forty (40) hours in any one (1) calendar week, in violation of the provisions of Article 3 (commencing at § 1810), Chapter 1, Part 7, Division 2 of the Labor Code, unless compensation for the workers so employed by Contractor is not less than one and one-half (1-1/2) times the basic rate of pay for all hours worked in excess of eight (8) hours per day.

#### **8.2.4 COSTS FOR AFTER HOURS INSPECTIONS**

If the work done after hours is required by the Contract Documents to be done outside the Contractor's or the Inspector of Record's regular working hours, the costs of any inspections, if required to be done outside normal working hours, shall be borne by the Owner.

If the Owner allows the Contractor to do work outside regular working hours for the Contractor's own convenience, the costs of any inspections required outside regular working hours, among other remedies, shall be invoiced to the Contractor by the Owner and withheld from progress payments and/or retention. Contractor shall give Owner at least 48 hours notice prior to working outside regular working hours.

If the Contractor elects to perform work outside the Inspector of Record's regular working hours, costs of any inspections required outside regular working hours, among other remedies, may be invoiced to the Contractor by the Owner and withheld from progress payments and/or retention.

#### **8.2.5 TIME FOR COMMENCEMENT BY SUBCONTRACTORS**

Unless otherwise provided in the Contract Documents, all Subcontractors shall commence their Work within two (2) consecutive business days after notice to them by the Contractor and shall prosecute their Work in accordance with the progress of the Work.

### **8.3 PROGRESS AND COMPLETION**

#### **8.3.1 TIME OF THE ESSENCE**

Time limits stated in the Contract Documents are of the essence of the Contract. By executing the Agreement the Contractor confirms that the Milestone Deadlines and Contract Time are reasonable periods for performing the Work.

### 8.3.2 NO COMMENCEMENT WITHOUT INSURANCE

The Contractor shall not knowingly, except by agreement or instruction of the Owner, in writing, commence operations on the Site or elsewhere prior to the effective date of insurance required by Article 11 to be furnished by the Contractor. The date of commencement of the Work shall not be changed by the effective date of such insurance.

### 8.3.3 EXPEDITIOUS COMPLETION

The Contractor shall proceed expeditiously to perform the Work, including Work directed pursuant to a CCD (see Section 7.3, above), with adequate forces, labor, materials, equipment, services and management, shall achieve all Milestone Deadlines, and shall achieve Completion within the Contract Time.

## 8.4 EXTENSIONS OF TIME - LIQUIDATED DAMAGES

Contractor waives all rights and remedies as to any delay experienced during the Work (including any right to rescind the Contract and any right to refuse to perform the Contract) except for the rights and remedies expressly allowed by the Contract (including but not limited to time extensions and delay damages pursuant to this Section 8.4.1 and Section 8.4.2 below, and termination pursuant to Section 14.1 below).

### 8.4.1 CONDITIONS ALLOWING FOR EXTENSIONS OF TIME TO COMPLETE THE WORK ONLY (EXCUSABLE DELAY)

The Contractor shall be granted a reasonable time extension under the Contract Documents, including but not limited to Sections 3.18 and 4.5 and Article 7, for excusable delays, which are those delays that meet each and every of the following conditions:

- (a) The delay was beyond the control of Contractor and its subcontractors and material suppliers;
- (b) The delay was caused by events that were not reasonably foreseeable to Contractor at the time of bidding;
- (c) All float in the schedule had been used, and the delay impacted and delayed the controlling items of Work (i.e., the as-built critical path, as determined from the as-planned schedule and the actual progress of the Work), thus delaying the achievement of a Milestone Deadline or the Completion of the whole Work within the Contract Time;
- (d) The delay was not caused by Contractor or its subcontractors or suppliers, including but not limited to their breaches of contract or the standard of care;
- (e) The delay was not associated with loss of time resulting from the necessity of submittals to Owner for approval, or from necessary Owner surveys, measurements, inspections and testing;
- (f) The delay was not caused by usual or common weather for the time of year, including usual or common severe weather; and
- (g) The delay could not have been prevented or mitigated by the exercise of care, prudence, foresight, and diligence by Contractor.



Excusable delays may include acts of God, acts of public enemy, acts of the Owner or anyone employed by it, acts of another contractor in performance of a contract (other than this Contract) with the Owner, fires, floods, epidemics, quarantine restrictions, labor disputes, unusual and uncommon weather for the time of year, unforeseen site conditions, or delays of subcontractors due to such causes. Owner shall take into consideration other relevant factors such as concurrent delays. Contractor has the burden of proving that any delay was excusable.

#### **8.4.2 COMPENSABLE DELAY (TIME AND MONEY)**

Compensable delays are those excusable delays for which Contractor is also entitled to money. To be compensable, an excusable delay must be one for which the Owner is responsible, where the delay was unreasonable under the circumstances involved, and where the delay was not within the contemplation of the parties; *however*, Contractor shall not be entitled to monetary compensation when (a) Contractor could have reasonably anticipated the delay and avoided or minimized the cost impacts of it, (b) there was a concurrent delay which does not qualify for monetary compensation under this paragraph, (c) the cause of the delay was reasonably unforeseen by the Owner or the delay was caused by factors beyond the control of the Owner, including but not limited to a delay under Section 2.2.8 above or a delay caused by a utility company's failure to perform despite Owner's reasonable arrangements for such performance; or (d) any other defense available to Owner under law or equity applies. Contractor has the burden of proving that any delay was excusable and compensable, including an analysis that establishes non-concurrency. Compensation shall be limited to field overhead (i.e., general conditions) and home office overhead, as may be allowed by law.

#### **8.4.3 NOTICE BY CONTRACTOR REQUIRED; PROCEDURES FOR DEMANDING ADDITIONAL TIME OR MONEY**

For notice and other required procedures related to requests by Contractor for additional time or money related to delay, Contractor shall comply with the Contract Documents, including but not limited to Sections 3.18 and 4.5, and Article 7, above.

#### **8.4.4 EARLY COMPLETION**

Regardless of the cause therefore, the Contractor may not maintain any Claim or cause of action against the Owner for damages incurred as a result of its failure or inability to Complete its Work on the Project in a shorter period than established in the Contract Documents, the parties stipulating that the period set forth in the Contract Documents is a reasonable time within which to perform the Work on the Project.

#### **8.4.5 LIQUIDATED DAMAGES**

Failure to Complete the Work within the Contract Time and in the manner provided for by the Contract Documents, or failure to complete any specified portion of the Work by a milestone deadline, shall subject the Contractor to liquidated damages as described in Article III of the Agreement and the Contract Documents. Accordingly, the parties agree that the amount set forth

in the Agreement shall be presumed to be the amount of damages which the Owner shall directly incur as a result of each calendar day by which Completion of the Work is delayed beyond the Contract Time as adjusted by Change Orders.

In addition, delaying another contractor's work on the Project or causing delay to the *completion* of the Project shall subject the Contractor to liquidated damages as described in Article III of the Agreement and the Contract Documents. Accordingly, the parties agree that the amount set forth in the Agreement shall be presumed to be the amount of damages which the Owner shall directly incur as a result of each calendar day by which Contractor delays the work of others on the Project or *completion* of the Project itself.

If liquidated damages accrue as described above, the Owner, in addition to all other remedies provided by law, shall have the right to assess and withhold as provided in Article III of the Agreement and the Contract Documents.

#### **8.5 GOVERNMENT APPROVALS**

Owner shall not be liable for any delays or damages related to the time required to obtain government approvals.

### **ARTICLE 9**

#### **PAYMENTS AND COMPLETION**

##### **9.1 CONTRACT SUM**

The Contract Sum is stated in the Agreement, later adjusted by Change Orders and Construction Change Directives, and is the total amount payable by the Owner to the Contractor for performance of the Work under the Contract Documents.

##### **9.2 COST BREAKDOWN**

###### **9.2.1 REQUIRED INFORMATION**

On forms approved by the Owner, the Contractor shall furnish the following:

- A. Within ten (10) days of the mailing, faxing or delivering of the Notice of Award of the Contract, a detailed breakdown of the Contract Sum (Schedule of Values) for each Project or Site. Each item in the schedule of values shall include its proper share of the overhead and profit.
- B. Within ten (10) days of the mailing, faxing or delivering of the Notice of Award of the Contract, a schedule of estimated monthly payment requests (cash flow) due the Contractor showing the values and construction time of the various portions of the Work to be performed by it and by its Subcontractors or material and equipment suppliers containing such supporting evidence as to its correctness

as the Owner may require;

- C. Five (5) days prior to the submission of a pay request, an itemized breakdown of work done for the purpose of requesting partial payments;
- D. Within ten (10) days of the mailing, faxing or delivering of the Notice of Award of the Contract, the name, address, telephone number, fax number, license number and classification, and for all projects over Twenty-five Thousand Dollars (\$25,000) the public works contractor registration number, of all of its Subcontractors and of all other parties furnishing labor, material, or equipment for its Contract, along with the amount of each such subcontract or the price of such labor, material, and equipment needed for its entire portion of the Work.

### **9.2.2 OWNER ACCEPTANCE REQUIRED**

The Owner shall review all submissions received pursuant to paragraph 9.2.1 in a timely manner. All submissions must be accepted by the Owner before becoming the basis of any payment.

### **9.3 APPLICATIONS FOR PAYMENT**

#### **9.3.1 PROCEDURE**

On or before the fifth (5th) day of each calendar month during the progress of the portion of the Work for which payment is being requested, the Contractor shall submit to the Architect, unless there is a construction manager for the Project or the Owner directs otherwise, an itemized Application for Payment for operations completed in accordance with the Schedule of Values through the end of the previous calendar month. Such application shall be notarized, if required, and supported by the following or such portion thereof as the applicable entity requires:

- A. The amount paid to the date of the Application to the Contractor, to all its Subcontractors, and all others furnishing labor, material, or equipment for its Contract;
- B. The amount being requested with the Application for Payment by the Contractor on its own behalf and separately stating the amount requested on behalf of each of the Subcontractors and all others furnishing labor, material, and equipment under the Contract;
- C. The balance that will be due to each of such entities after said payment is made;
- D. A certification that the Record Drawings and Annotated Specifications are current;
- E. The Owner approved additions to and subtractions from the Contract Sum and Time;

- F. A summary of the retentions (each Application shall provide for retention, as set out in Article 9.6);
- G. Material invoices, evidence of equipment purchases, rentals, and other support and details of cost as the Owner may require from time to time;
- H. The percentage of Completion of the Contractor's Work by line item;
- I. A statement showing all payments made by the Contractor for labor and materials on account of the Work covered in the preceding Application for Payment. Such applications shall not include requests for payment of amounts the Contractor does not intend to pay to subcontractors or others because of a dispute or other reason; and
- J. Contractor's monthly reports, daily reports, and monthly schedule updates for all months of Work prior to the Application for Payment that Contractor has not previously submitted.

### **9.3.2 PURCHASE OF MATERIALS AND EQUIPMENT**

As the Contractor is required to order, obtain, and store materials and equipment sufficiently in advance of its Work at no additional cost or advance payment from Owner, to assure that there will be no delays, payment by the Owner for stored material shall be made only in unusual circumstances where the Architect specifically recommends, and Owner specifically approves the payment in writing. If payments are to be made on account of materials and equipment not incorporated in the Work, but delivered and suitably stored at the Site or at some other location agreed upon in writing by the Owner, the payments shall be conditioned upon submission by the Contractor, Subcontractor, or vendor of bills of sale and such other documents satisfactory to the Owner to establish the Owner's title to such materials or equipment free of all liens and encumbrances, and otherwise protect the Owner's interest, including, without limitation, provision of applicable insurance and transportation to the Site. All stored items shall be inventoried, specified by identification numbers (if applicable), released to the Owner by sureties of the Contractor and the Subcontractor and, if stored off-Site, stored only in a bonded warehouse.

### **9.3.3 WARRANTY OF TITLE**

The Contractor warrants that title to all Work covered by an Application for Payment will pass to the Owner no later than the time of payment. The Contractor further warrants that upon submittal of an Application for Payment all Work for which Certificates for Payment have been previously issued and payments received from the Owner shall, to the best of the Contractor's knowledge, information, and belief, be free and clear of liens, claims, security interests, or encumbrances in favor of the Contractor, Subcontractors, material and equipment suppliers, or other persons or entities making a claim by reason of having provided labor, materials, and equipment relating to the Work. Transfer of title to Work does not constitute a waiver by Owner

of any defects in the Work.

#### **9.4 REVIEW OF PROGRESS PAYMENT**

##### **9.4.1 OWNER ACCEPTANCE**

The Owner will, within seven (7) days after receipt of the Contractor's Application for Payment, either accept such payment or notify the Contractor in writing of the Owner's reasons for withholding acceptance in whole or in part as provided in paragraph 9.5.1.

##### **9.4.2 OWNER'S REVIEW**

The review of the Contractor's Application for Payment by the Owner will be based, at least in part, on the Owner's observations at the Site and the data comprising the Application for Payment that the Work has progressed to the point indicated. The review is also subject to an evaluation of the Work for conformance with the Contract Documents, to results of subsequent tests and inspections, to minor deviations from the Contract Documents correctable prior to Completion, and to specific qualifications expressed by the Owner. The Owner may reject the Application for Payment if it is not complete under section 9.3. The issuance of a Certificate for Payment will constitute a representation that the Contractor is entitled to payment in the amount certified, subject to any specific qualifications Owner expresses in the Certificate for Payment. However, Contractor's entitlement to payment may be affected by subsequent evaluations of the Work for conformance with the Contract Documents, test and inspections and discovery of minor deviations from the Contract Documents correctable prior to Completion. The issuance of a Certificate for Payment will not be a waiver by the Owner of any defects in the Work covered by the Application for Payment, nor will it be a representation that the Owner has:

- A. Made exhaustive or continuous on-Site inspections to check the quality or quantity of the Work;
- B. Reviewed construction means, methods, techniques, sequences, or procedures;
- C. Reviewed copies of requisitions received from Subcontractors, material and equipment suppliers, and other data requested by the Owner to substantiate the Contractor's right to payment; or
- D. Made an examination to ascertain how or for what purpose the Contractor has used money previously paid on account of the Contract Sum.

#### **9.5 DECISIONS TO WITHHOLD PAYMENT**

##### **9.5.1 REASONS TO WITHHOLD PAYMENT**

The Owner may withhold from a progress payment, in whole or in part, to such extent as may be necessary to protect the Owner due to any of the following:

- A. Defective or incomplete Work not remedied;
- B. Stop Payment Notices. For any stop payment notice, the Owner shall withhold the amount stated in the stop payment notice, the stop notice claimant's anticipated interest and court costs and an amount to provide for the public entity's reasonable cost of any litigation pursuant to the stop payment notice. For any stop payment notice action the parties resolve before judgment is entered, Owner has the right to permanently withhold for any reasonable cost of litigation for that stop payment notice, even if it exceeds the amount originally withheld by Owner for the estimated reasonable cost of litigation. However, if (1) the Contractor at its sole expense provides a bond or other security satisfactory to the Owner in the amount of at least one hundred twenty-five percent (125%) of the claim, in a form satisfactory to the Owner, which protects the Owner against such claim, and (2) the Owner chooses to accept the bond, then Owner would release the withheld stop payment notice funds to the Contractor, except that Owner may permanently withhold for any reasonable cost of litigation. Any stop payment notice release bond shall be executed by a California admitted, fiscally solvent surety, completely unaffiliated with and separate from the surety on the payment and performance bonds, that does not have any assets pooled with the payment and performance bond sureties.
- C. Liquidated damages against the Contractor, whether already accrued or estimated to accrue in the future;
- D. Reasonable doubt that the Work can be Completed for the unpaid balance of any Contract Sum or within the Contract Time;
- E. Damage to the property or work of the Owner, another contractor, or subcontractor;
- F. Unsatisfactory prosecution of the Work by the Contractor;
- G. Failure to store and properly secure materials;
- H. Failure of the Contractor to submit on a timely basis, proper and sufficient documentation required by the Contract Documents, including, without limitation, monthly progress schedules, shop drawings, submittal schedules, schedule of values, product data and samples, proposed product lists, executed change orders, and verified reports;
- I. Failure of the Contractor to maintain record drawings;
- J. Erroneous estimates by the Contractor of the value of the Work performed, or other false statements in an Application for Payment;
- K. Unauthorized deviations from the Contract Documents;

- L. Failure of the Contractor to prosecute the Work in a timely manner in compliance with established progress schedules and Completion deadlines;
- M. Subsequently discovered evidence or observations nullifying the whole or part of a previously issued Certificate for Payment;
- N. Failure by Contractor to pay Subcontractors or material suppliers as required by Contract or law, which includes but is not limited to Contractor's failure to pay prevailing wage and any assessment of statutory penalties;
- O. Overpayment to Contractor on a previous payment;
- P. Credits owed to Owner for reduced scope of work or work that Contractor will not perform;
- Q. The estimated cost of performing work pursuant to Section 2.4;
- R. Actual damages related to false claims by Contractor;
- S. Breach of any provision of the Contract Documents;
- T. Owner's potential or actual loss, liability or damages caused by the Contractor; and
- U. As permitted by other provisions in the Contract or as otherwise allowed by law, including statutory penalties Owner or other entities assessed against Contractor. (See e.g., Labor Code section 1813 (working hours) or Public Contract Code section 4110 (subcontractor listings and substitutions))

Owner may, but is not required to, provide to Contractor written notice of the items for which Owner is withholding amounts from a progress payment.

To claim a breach of contract or violation of law based on wrongful withholding by the Owner from a progress payment or based on a late progress payment, or if Contractor otherwise disputes any progress payment or lack thereof, within fifteen (15) days of the alleged breach of contract, violation of law, or late or disputed progress payment Contractor shall submit a Claim pursuant and subject to Sections 4.5.3-4.5.6. The Contractor need not submit a Notice of Potential Change or a Change Order Request.

For any withheld amount based on an estimate where the actual amount later becomes known and certain, no later than the final accounting for the Contract the Owner will release any amount withheld over that certain and known amount. If the certain and known amount exceeds the amount previously withheld, Owner may withhold additional amounts from Contractor to cover the excess amount. If available funds are not sufficient, Contractor shall pay Owner the difference.

Despite any withholding from a progress payment, or any other dispute about a progress payment, Contractor shall continue to expeditiously perform the Work pursuant to the Contract Documents, including but not limited to General Conditions sections 4.5.8, 7.1.1, 8.3.1, and 8.3.3.

#### **9.5.2 PAYMENT AFTER CURE**

When Contractor removes or cures the grounds for withholding amounts, payment shall be made for amounts withheld because of them. No interest shall be paid on any retainage or amounts withheld due to the failure of the Contractor to perform in accordance with the terms and conditions of the Contract Documents.

#### **9.5.3 OVERPAYMENT AND/OR FAILURE TO WITHHOLD**

Neither Owner's overpayment to Contractor, nor Owner's failure to withhold an amount from payment that Owner had the right to withhold, shall constitute a waiver by Owner of its rights to withhold those amounts from future payments to Contractor or to otherwise pursue recovery of those amounts from Contractor.

### **9.6 PROGRESS PAYMENTS**

#### **9.6.1 PAYMENTS TO CONTRACTOR**

Unless otherwise stated in the Contract Documents, within thirty (30) days after receipt of an undisputed and properly submitted Application for Payment, Contractor shall be paid a sum equal to ninety-five percent (95%) of the undisputed value of the Work performed up to the last day of the previous month, less the aggregate of previous payments; and Owner shall retain the other five percent (5%) of the undisputed value of the Work. The value of the Work completed shall be an estimate only, no inaccuracy or error in said estimate shall operate to release the Contractor, or any bondsman, from damages arising from such Work or from enforcing each and every provision of this Contract, and the Owner shall have the right subsequently to correct any error made in any estimate for payment. Contractor shall base an Application for Payment only on the original Contract Sum plus any fully executed and Board-approved Change Orders. Contractor shall not include Notices of Potential Claims, CORs, Claims or disputed amounts.

The Contractor shall not be entitled to have any payment requests processed, or be entitled to have any payment made for work performed, so long as any lawful or proper direction given by the Owner concerning the Work, or any portion thereof, remains uncomplished with. Payment shall not be a waiver of any such direction.

#### **9.6.2 PAYMENTS TO SUBCONTRACTORS**

No later than ten (10) days after receipt of payment from Owner, pursuant to Business and Professions Code section 7108.5, the Contractor shall pay to each Subcontractor, out of the amount paid to the Contractor on account of such Subcontractor's portion of the Work, the



amount to which said Subcontractor is entitled, reflecting percentages actually retained from payments to the Contractor on account of such Subcontractor's portion of the Work. The Contractor shall, by appropriate agreement with each Subcontractor, require each Subcontractor to make payments to Sub-subcontractors in a similar manner.

### **9.6.3 PERCENTAGE OF COMPLETION OR PAYMENT INFORMATION**

The Owner will, on request, furnish to a Subcontractor, if practicable, information regarding percentages of Completion or amounts applied for by the Contractor, and action taken thereon by the Owner, on account of portions of the Work done by such Subcontractor.

### **9.6.4 NO OBLIGATION OF OWNER FOR SUBCONTRACTOR PAYMENT**

The Owner shall have no obligation to pay, or to see to the payment of, money to a Subcontractor except as may otherwise be required by law.

### **9.6.5 PAYMENT TO SUPPLIERS**

Payment to material or equipment suppliers shall be treated in a manner similar to that provided in paragraphs 9.6.2, 9.6.3 and 9.6.4.

### **9.6.6 PAYMENT NOT CONSTITUTING APPROVAL OR ACCEPTANCE**

An accepted Application for Payment, issuance of a Certificate for Payment, a progress payment, or partial or entire use or occupancy of the Project by the Owner shall not constitute acceptance or approval of any portion of the Work, especially any Work not in accordance with the Contract Documents.

### **9.6.7 JOINT CHECKS**

Owner shall have the right, if necessary for the protection of the Owner, to issue joint checks made payable to the Contractor and Subcontractors and/or material or equipment suppliers. The joint check payees shall be responsible for the allocation and disbursement of funds included as part of any such joint payment. However, Owner has no duty to issue joint checks. In no event shall any joint check payment be construed to create any contract between the Owner and a Subcontractor of any tier, any obligation from the Owner to such Subcontractor, or rights in such Subcontractor against the Owner.

## **9.7 COMPLETION OF THE WORK**

### **9.7.1 CLOSE-OUT PROCEDURES**

When the Contractor considers that the Work is Complete and submits a written notice to Owner requesting an inspection of the Work, the Owner shall review the Work and prepare and submit to the Contractor a comprehensive list of items to be Completed or corrected (the "Punch List"). The Punch List shall include all outstanding obligations of Contractor, including training, start-

up, testing, and submission to Owner of all required documentation (e.g., written guarantees, warranties, invoices, as-built drawings, manuals, bonds, and the documents described in Sections 9.3 and 9.9). The Contractor and/or its Subcontractors shall proceed promptly to Complete and correct items on the Punch List. Failure to include an item on the Punch List does not alter the responsibility of the Contractor to Complete all Work (including the omitted item) in accordance with the Contract Documents, and to Complete or correct the Work so long as the statute of limitations (or repose) has not run.

When the Contractor believes the Punch List Work is Complete and in accordance with the Contract Documents, it shall then submit a request for an additional inspection by the Owner to determine Completion. Owner shall again inspect the Work and inform the Contractor of any items that are not complete or correct. Contractor shall promptly Complete or correct items until no items remain.

After the Work, including all Punch List Work, is inspected and informally deemed by the Owner to be Complete, the Owner's governing body may formally accept the Work as Complete at a meeting of the governing body. Warranties required by the Contract Documents shall commence on the date of Contractor's Completion of the Work (see Sections 3.5, 12.2.5, and 12.2.6).

Owner may record a Notice of Completion as allowed by Civil Code section 9200 *et seq.*

#### **9.7.2 COSTS OF MULTIPLE INSPECTIONS**

More than two (2) requests by Contractor to make inspections to confirm Completion as required under paragraph 9.7.1 shall be considered an additional service of Owner, and all subsequent costs will be invoiced to Contractor and withheld from remaining payments.

#### **9.8 PARTIAL OCCUPANCY OR USE**

The Owner may occupy or use any completed, or partially completed, portion of the Work at any stage prior to acceptance, or prior to Completion if there is no formal acceptance. Occupancy or use of any portion of the Work, or the whole Work, shall not constitute approval or acceptance of it, nor shall such occupancy or use relieve Contractor of any of its obligations under the Contract Documents regarding that portion of, or the whole, Work.

The Owner and the Contractor shall agree in writing to the responsibilities assigned to each of them for payments, security, maintenance, heat, utilities, damage to the Work, insurance, the period for correction of the Work, and the commencement of warranties required by the Contract Documents. When the Contractor considers a portion complete, the Contractor may request an inspection of that portion and preparation of a Punch List by the Owner for that portion, as set forth for the entire Work under paragraph 9.7.1; however, such inspection and Punch List shall not act as any form of approval or acceptance of that portion of the Work, or of any Work not complying with the requirements of the Contract, and that portion shall be subject to subsequent inspections and Punch Lists.

Immediately prior to such partial occupancy or use, the Owner, the Architect and the Contractor shall jointly inspect the area to be occupied or portion of the Work to be used in order to determine and record the condition of the Work.

## **9.9 FINAL PROGRESS PAYMENT AND RELEASE OF RETENTION**

### **9.9.1 FINAL APPLICATION FOR PROGRESS PAYMENT**

When, pursuant to Section 9.7.1, the Owner finds all of the Work is Completed in accordance with the Contract Documents, it shall so notify Contractor, who shall then submit to the Owner its final Application for Payment.

Upon receipt and approval of such final Application for Payment, the Owner shall issue a final Certificate of Payment, based on its knowledge, information, and belief, and on the basis of its observations, inspections, and all other data accumulated or received by the Owner in connection with the Work, that such Work has been Completed in accordance with the Contract Documents. If required to do so under Labor Code section 1773.3, subd. (d), Owner shall withhold final payment.

### **9.9.2 PROCEDURES FOR APPLICATION FOR FINAL PROGRESS PAYMENT**

The Application for Final Progress Payment pursuant to Section 9.9.1 shall be accompanied by the same details as set forth in paragraph 9.3, and in addition, the following conditions must be fulfilled:

- A. The Work shall be Complete, and the Contractor shall have made, or caused to have been made, all corrections to the Work which are required to remedy any defects therein, to obtain compliance with the Contract Documents or any requirements of applicable codes and ordinances, or to fulfill any of the orders or directions of Owner required under the Contract.
- B. Each Subcontractor shall have delivered to the Contractor all written guarantees, warranties, applications, and bonds required by the Contract Documents for its portion of the Work, and Contractor delivered them to the Owner.
- C. The Contractor shall deliver to the Owner (i) reproducible final Record Drawings and Annotated Specifications showing the Contractor's Work "as built," with the Contractor's certification of the accuracy of the Record Drawings and Annotated Specifications, (ii) all warranties and guarantees, (iii) operation and maintenance instructions, manuals and materials for equipment and apparatus, and (iv) all other documents required by the Contract Documents.
- D. Contractor shall provide extensive assistance in the utilization of any equipment or system such as initial start-up or testing, adjusting and balancing, preparation of operation and maintenance manuals and training personnel for operation and maintenance.

Acceptance of Final Progress Payment shall constitute a complete waiver of Claims except for those previously identified in writing and identified by that payee as unsettled at the time of Final Progress Payment.

### **9.9.3 RELEASE OF RETAINAGE**

Owner shall withhold not less than 5% of the Contract Sum (“retainage,” or “retention”) until Completion and acceptance of the Project, per Public Contract Code section 9203.

Owner may withhold from release or payment of retainage up to 150% of disputed amounts, including but not limited to the issues listed in Section 9.5. If retainage is held in an escrow account pursuant to an escrow agreement under Public Contract Code section 22300 (see Section 9.10) and Owner withholds from release of retainage based on a breach of the Contract, or other default, by Contractor, Owner may withdraw the withheld retainage from the escrow account.

Owner shall release the undisputed retainage within sixty (60) days after Completion of the Project. For this purpose, “Completion” is defined in Public Contract Code section 7107(c). No interest shall be paid on any retainage, or on any amounts withheld, except as provided to the contrary in any Escrow Agreement and General Conditions between the Owner and the Contractor under Public Contract Code section 22300.

To claim a breach of contract or violation of law based on wrongful withholding by the Owner from retention or based on a late payment or late release of retention, or if Contractor otherwise disputes any payment or release of retention or lack thereof, within fifteen (15) days of the alleged breach of contract, violation of law, or late or disputed payment/release of retention Contractor shall submit a Claim pursuant and subject to Sections 4.5.3-4.5.6. The Contractor need not submit a Notice of Potential Change or a Change Order Request.

### **9.10 SUBSTITUTION OF SECURITIES**

In accordance with section 22300 of the Public Contract Code, the Owner will permit the substitution of securities for any retention monies withheld by the Owner to ensure performance under the Contract. At the request and expense of the Contractor, securities equivalent to the amount withheld shall be deposited with the Owner, or with a state or federally chartered bank as the escrow agent, who shall then pay such retention monies to the Contractor. Upon Completion of the Contract, the securities shall be returned to the Contractor if Owner has no basis to withhold under the Contract Documents.

Securities eligible for investment under this section shall include those listed in Government Code section 16430, bank or savings and loan certificates of deposit, interest-bearing, demand-deposit accounts, standby letters of credit, or any other security mutually agreed to by the Contractor and the Owner.

The Contractor shall be the beneficial owner of any securities substituted for monies withheld and shall receive any interest thereon.

Any escrow agreement entered by Owner and Contractor pursuant to Public Contract Code section 22300, shall be substantially similar to the form set forth in Public Contract Code section 22300.

## **ARTICLE 10**

### **PROTECTION OF PERSONS AND PROPERTY**

#### **10.1 SAFETY PRECAUTIONS AND PROGRAMS**

##### **10.1.1 CONTRACTOR RESPONSIBILITY**

The Contractor shall have responsibility for initiating, maintaining, and supervising all safety precautions and programs in connection with the performance of the Contract. Each Contractor shall designate a responsible member of its organization whose duties shall include loss and accident prevention, and who shall have the responsibility and full authority to enforce the program. This person shall attend meetings with the representatives of the various Subcontractors employed to ensure that all employees understand and comply with the programs. Contractor will ensure that his employees and Subcontractors cooperate and coordinate safety matters with any other contractors on the Project to form a joint safety effort.

##### **10.1.2 SUBCONTRACTOR RESPONSIBILITY**

Subcontractors have the responsibility for participating in, and enforcing, the safety and loss prevention programs established by the Contractor for the Project, which will cover all Work performed by the Contractor and its Subcontractors. Each Subcontractor shall designate a responsible member of its organization whose duties shall include loss and accident prevention, and who shall have the responsibility and full authority to enforce the program. This person shall attend meetings with the representatives of the various Subcontractors employed to ensure that all employees understand and comply with the programs.

##### **10.1.3 COOPERATION**

All Subcontractors and material or equipment suppliers, shall cooperate fully with Contractor, the Owner, and all insurance carriers and loss prevention engineers.

##### **10.1.4 ACCIDENT REPORTS**

Subcontractors shall promptly report in writing to the Contractor all accidents whatsoever arising out of, or in connection with, the performance of the Work, whether on or off the Site, which caused death, personal injury, or property damage, giving full details and statements of witnesses. In addition, if death or serious injuries or serious damages are caused, the accident shall be reported immediately by telephone or messenger. Contractor shall thereafter promptly report the facts in writing to the Owner giving full details of the accident.

### **10.1.5 FIRST-AID SUPPLIES AT SITE**

The Contractor will provide and maintain at the Site first-aid supplies for minor injuries.

## **10.2 SAFETY OF PERSONS AND PROPERTY**

### **10.2.1 THE CONTRACTOR**

The Contractor shall take reasonable precautions for the safety of, and shall provide reasonable protection to prevent damage, injury, or loss to:

- A. Employees on the Work and other persons who may be affected thereby;
- B. The Work, material, equipment, tools, construction equipment, and machinery to be incorporated therein or necessary for the proper execution and Completion of the Work, whether in storage on or off the Site, under the care, custody, or control of the Contractor or the Contractor's Subcontractors or Sub-subcontractors; and
- C. Other property at the Site or adjacent thereto such as trees, shrubs, lawns, walks, pavement, roadways, structures, and utilities not designated for removal, relocation, or replacement in the course of construction.

### **10.2.2 CONTRACTOR NOTICES**

The Contractor shall give notices and comply with applicable laws, ordinances, rules, regulations, and lawful orders of public authorities bearing on the safety of persons or property or their protection from damage, injury, or loss.

### **10.2.3 SAFETY BARRIERS AND SAFEGUARDS**

The Contractor shall erect and maintain, as required by existing conditions and performance of the Contract, reasonable safeguards for safety and protection, including posting danger signs and other warnings against hazards, promulgating safety regulations, and notifying owners and users of adjacent Sites and utilities.

### **10.2.4 USE OR STORAGE OF HAZARDOUS MATERIAL**

When use or storage of explosives, other hazardous materials or equipment, or unusual methods are necessary for execution of the Work, the Contractor shall exercise utmost care and carry on such activities under supervision of properly qualified personnel. The Contractor shall notify the Owner any time that explosives or hazardous materials are expected to be stored on Site. Location of storage shall be coordinated with the Owner and local fire authorities.

### **10.2.5 FINGERPRINTING**

At its own expense, Contractor shall comply with all fingerprinting requirements under law and Contract, including but not limited to the requirements of Education Code section 45125.2 and the Independent Contractor Student Contact Form which is a part of the Contract. Contractor shall hold harmless, defend and indemnify the Owner under section 3.16, for any costs, including attorneys' fees, Owner incurs from Contractor's failure to comply.

## **10.3 PROTECTION OF WORK AND PROPERTY**

### **10.3.1 PROTECTION OF WORK**

The Contractor and Subcontractors shall continuously protect the Work, the Owner's property, and the property of others, from damage, injury, or loss until the earlier of formal acceptance of the Work or Completion of the Work. The Contractor and Subcontractors shall make good any such damage, injury, or loss, except such as may be solely due to, or caused by, agents or employees of the Owner; except that for projects not solely funded through revenue bonds, (a) Contractor shall not be responsible for damages caused by a tidal wave to the extent that the damages exceed 5% of the Contract Sum, and (b) Contractor shall not be responsible for damages caused by an earthquake above 3.5 on the Richter Scale in magnitude to the extent that the damages exceed 5% of the Contract Sum, per Public Contract Code §7105(a).

### **10.3.2 PROTECTION FOR ELEMENTS**

The Contractor will remove all mud, water, or other elements as may be required for the proper protection and prosecution of its Work. The Contractor shall at all times provide heat, coverings, and enclosures necessary to maintain adequate protection against weather so as to preserve the Work, materials, equipment, apparatus, and fixtures free from injury or damage.

### **10.3.3 SHORING AND STRUCTURAL LOADING**

The Contractor shall not impose structural loading upon any part of the Work under construction or upon existing construction on or adjacent to the Site in excess of safe limits, or loading such as to result in damage to the structural, architectural, mechanical, electrical, or other components of the Work. The design of all temporary construction equipment and appliances used in construction of the Work and not a permanent part thereof, including, without limitation, hoisting equipment, cribbing, shoring, and temporary bracing of structural steel, is the sole responsibility of the Contractor. All such items shall conform to the requirements of governing codes and all laws, ordinances, rules, regulations, and orders of all authorities having jurisdiction. The Contractor shall take special precautions, such as shoring of masonry walls and temporary tie bracing of structural steel work, to prevent possible wind damage during construction of the Work. The installation of such bracing or shoring shall not damage or cause damage to the Work in place or the Work installed by others. Any damage which does occur shall be promptly repaired by the Contractor at no cost to the Owner.

#### **10.3.4 CONFORMANCE WITHIN ESTABLISHED LIMITS**

The Contractor and Subcontractors shall confine their construction equipment, the storage of materials, and the operations of workers to the limits indicated by laws, ordinances, permits, and the limits established by the Owner, and shall not unreasonably encumber the premises with construction equipment or materials.

#### **10.3.5 SUBCONTRACTOR ENFORCEMENT OF RULES**

Subcontractors shall enforce the Owner's and the Contractor's instructions, laws, and regulations regarding signs, advertisements, fires, smoking, the presence of liquor, and the presence of firearms by any person at the Site.

#### **10.3.6 SITE ACCESS**

The Contractor and the Subcontractors shall use only those ingress and egress routes designated by the Owner, observe the boundaries of the Site designated by the Owner, park only in those areas designated by the Owner, which areas may be on or off the Site, and comply with any parking control program established by the Owner such as furnishing license plate information and placing identifying stickers on vehicles.

#### **10.3.7 PROTECTION OF MATERIALS**

The Contractor and the Subcontractors shall receive, count, inspect for damage, record, store, and protect construction materials for the Work and Subcontractors shall promptly send to the Contractor evidence of receipt of such materials, indicating thereon any shortage, change, or damage (failure to so note shall constitute acceptance by the Subcontractor of financial responsibility for any shortage).

### **10.4 EMERGENCIES**

#### **10.4.1 EMERGENCY ACTION**

In an emergency affecting the safety of persons or property, the Contractor shall take any action necessary, at the Contractor's discretion, to prevent threatened damage, injury, or loss. Additional money or extension of time claimed by the Contractor on account of an emergency shall be determined as provided in Section 4.5 and Article 7.

#### **10.4.2 ACCIDENT REPORTS**

The Contractor shall promptly report in writing to the Owner all accidents arising out of or in connection with the Work, which caused death, personal injury, or property damage, giving full details and statements of any witnesses. In addition, if death, serious personal injuries, or serious property damages are caused, the accident shall be reported immediately by telephone or messenger to the Owner.



## **10.5 HAZARDOUS MATERIALS**

### **10.5.1 DISCOVERY OF HAZARDOUS MATERIALS**

In the event the Contractor encounters or suspects the presence on the Site material reasonably believed to be asbestos, polychlorinated biphenyl (PCB), or any other material defined as being hazardous by section 25249.5 of the California Health and Safety Code, which (a) has not been rendered harmless, and (b) the handling or removal of which is not within the scope of the Work, the Contractor shall immediately stop Work in the area affected and report the condition to the Owner and the Architect in writing, whether such material was generated by the Contractor, another contractor, or the Owner. The Work in the affected area shall not thereafter be resumed, except by written agreement of the Owner and the Contractor, if in fact the material is asbestos, polychlorinated biphenyl (PCB), or other hazardous material, and has not been rendered harmless. The Work in the affected area shall be resumed only in the absence of asbestos, polychlorinated biphenyl (PCB), or other hazardous material, or when it has been rendered harmless by written agreement of the Owner and the Contractor.

### **10.5.2 HAZARDOUS MATERIAL WORK LIMITATIONS**

In the event that the presence of hazardous materials is suspected or discovered on the Site, the Owner shall retain an independent testing laboratory to determine the nature of the material encountered and whether corrective measures or remedial action is required. The Contractor shall not be required pursuant to Article 7 to perform without consent any Work in the affected area of the Site relating to asbestos, polychlorinated biphenyl (PCB), or other hazardous material, until any known or suspected hazardous material has been removed, or rendered harmless, or determined to be harmless by Owner, as certified by an independent testing laboratory and/or approved by the appropriate government agency.

### **10.5.3 INDEMNIFICATION BY OWNER FOR HAZARDOUS MATERIAL NOT CAUSED BY CONTRACTOR**

In the event the presence of hazardous materials on the Site is not caused by the Contractor, Owner shall pay for all costs of testing and remediation, if any, and shall compensate Contractor for any delay or additional costs incurred in accordance with the applicable provisions of Article 7 and 8 herein. Owner shall defend, indemnify and hold harmless the Contractor and its agents, officers, directors and employees from and against any and all claims, damages, losses, costs and expenses incurred in connection with or arising out of, or relating to, the performance of the Work in the area affected by the hazardous material, except to the extent the claims, damages, losses, costs, or expenses were caused by Contractor's active negligence, sole negligence or willful misconduct. By providing this indemnification, Owner does not waive any immunities.

### **10.5.4 NATURALLY OCCURRING ASBESTOS**

If the Site is found to contain naturally occurring asbestos (asbestos naturally contained in rocks which can become airborne when released "NOA"), in addition to complying with applicable provisions in sections 10.5.1-10.5.3 above, Contractor shall comply with, and be solely responsible for, all applicable NOA requirements of the California Air Resources Board

(CARB), California Department of Industrial Relations, California Division of Occupational Safety and Health (Cal/OSHA), any local air quality management district with jurisdiction over the Site, the County, and all other applicable federal, State and local governmental entities. This compliance and responsibility includes, but is not limited to, dust control mitigation measures and a monitoring plan.

#### **10.5.5 INDEMNIFICATION BY CONTRACTOR FOR HAZARDOUS MATERIAL CAUSED BY CONTRACTOR**

In the event the presence of hazardous materials on the Site is caused by Contractor, Subcontractors, materialmen or suppliers, the Contractor shall pay for all costs of testing and remediation, if any, and shall compensate the Owner for any additional costs incurred as a result of the generation of hazardous material on the Project Site. In addition, the Contractor shall defend, indemnify and hold harmless Owner and its agents, officers, and employees from and against any and all claims, damages, losses, costs and expenses incurred in connection with, arising out of, or relating to, the presence of hazardous material on the Site, except to the extent the claims, damages, losses, costs, or expenses were caused by Owner's active negligence, sole negligence or willful misconduct.

#### **10.5.6 TERMS OF HAZARDOUS MATERIAL PROVISION**

The terms of this Hazardous Material provision shall survive the Completion of the Work and/or any termination of this Contract.

#### **10.5.7 ARCHEOLOGICAL MATERIALS**

In the event the Contractor encounters or reasonably suspects the presence on the Site of archeological materials, the Contractor shall immediately stop Work in the area affected and report the condition to the Owner and the Architect in writing. The Work in the affected area shall not thereafter be resumed, except after Contractor's receipt of written notice from the Owner.

### **ARTICLE 11**

#### **INSURANCE AND BONDS**

##### **11.1. CONTRACTOR'S LIABILITY INSURANCE**

###### **11.1.1 LIABILITY INSURANCE REQUIREMENTS**

11.1.1 By the earlier of the deadline set forth in the Instructions to Bidders or the commencement of the Work and within limits acceptable to the Owner, the Contractor shall purchase from and maintain in a company or companies lawfully authorized to do business in California as admitted carriers with a financial rating of at least A+, Class XII status as rated in the most recent edition of Best's Insurance Reports such commercial general liability insurance per occurrence for bodily injury, personal injury and property damage as set forth in the

Agreement and automobile liability insurance per accident for bodily injury and property damage combined single limit as set forth in the Agreement as will protect the Contractor from claims set forth below, which may arise out of or result from the Contractor's operations under the Contract and for which the Contractor may be legally liable, whether such operations are by the Contractor, by a Subcontractor, by Sub-subcontractor, by anyone directly or indirectly employed by any of them, or by anyone for whose acts any of them may be liable:

- 11.1.1.1 claims for damages because of bodily injury (including emotional distress), sickness, disease, or death of any person other than the Contractor's employees. This coverage shall be provided in a form at least as broad as Insurance Services Office (ISO) Form CG 0001 11188;
- 11.1.1.2 claims for damages arising from personal or advertising injury in a form at least as broad as ISO Form CG 0001 11188;
- 11.1.1.3 claims for damages because of injury or destruction of tangible property, including loss of use resulting therefrom, arising from operations under the Contract Documents; and
- 11.1.1.4 claims for damages because of bodily injury, death of a person, or property damage arising out of the ownership, maintenance, or use of a motor vehicle, all mobile equipment, and vehicles moving under their own power and engaged in the Work; and
- 11.1.1.5 claims involving blanket contractual liability applicable to the Contractor's obligations under the Contract Documents, including liability assumed by and the indemnity and defense obligations of the Contractor and the Subcontractors; and
- 11.1.1.6 claims involving Completed Operations, Independent Contractors' coverage, and Broad Form property damage, without any exclusions for collapse, explosion, demolition, underground coverage, and excavating. (XCU)

If commercial general liability insurance or another insurance form with a general aggregate limit is used, either the general aggregate limit shall apply separately to the project location (with the ISO CG 2501 or insurer's equivalent endorsement provided to the Owner) or the general aggregate limit shall be twice the required occurrence limit.

Any deductible or self-insured retention must be declared to and approved by the Owner. At the option of the Owner, either the insurer shall reduce or eliminate such deductibles or self-insured retentions as respects the Owner, its Board of Trustees, members of its Board of Trustees, officers, employees, agents and volunteers; or the Contractor shall procure a bond guaranteeing payment of losses and related investigations, claim administration and defense expenses.

#### **11.1.2 SUBCONTRACTOR INSURANCE REQUIREMENTS**

The Contractor shall require its Subcontractors and any Sub-subcontractors to take out and maintain similar public liability insurance and property damage insurance, in a company or companies lawfully authorized to do business in California as admitted carriers with a financial rating of at least A+, Class XII status as rated in the most recent edition of Best's Insurance Reports, in like amounts and scope of coverage.

#### **11.1.3 OWNER'S INSURANCE**

The Owner shall be responsible for purchasing and maintaining the Owner's usual liability insurance. Optionally, the Owner may purchase and maintain other insurance for self protection against claims which may arise from operations under the Contract. The Contractor shall not be responsible for purchasing and maintaining this optional Owner's liability insurance unless specifically required by the Contract Documents.

#### **11.1.4 ADDITIONAL INSURED ENDORSEMENT REQUIREMENTS**

The Contractor shall name, on any policy of insurance, the Owner and the Architect as additional insureds. Subcontractors shall name the Contractor, the Owner and the Architect as additional insureds. The Additional Insured Endorsement included on all such insurance policies shall state that coverage is afforded the additional insured with respect to claims arising out of operations performed by or on behalf of the insured. If the additional insureds have other insurance which is applicable to the loss, such other insurance shall be excess to any policy of insurance required herein. The amount of the insurer's liability shall not be reduced by the existence of such other insurance.

#### **11.1.5 WORKERS' COMPENSATION INSURANCE**

During the term of this Contract, the Contractor shall provide workers' compensation insurance for all of the Contractor's employees engaged in Work under this Contract on or at the Site of the Project and, in case any of the Contractor's work is sublet, the Contractor shall require the Subcontractor to provide workers' compensation insurance for all the Subcontractor's employees engaged in Work under the subcontract. Any class of employee or employees not covered by a Subcontractor's insurance shall be covered by the Contractor's insurance. In case any class of employees engaged in Work under this Contract on or at the Site of the Project is not protected under the Workers' Compensation laws, the Contractor shall provide or cause a Subcontractor to provide adequate insurance coverage for the protection of those employees not otherwise protected. The Contractor shall file with the Owner certificates of insurance as required under this Article and in compliance with Labor Code section 3700.

If the contractor fails to maintain such insurance, the Owner may take out compensation insurance which the Owner might be liable to pay under the provisions of the Act by reason of an employee of the Contractor being injured or killed, and withhold from progress payments and/or retention the amount of the premium for such insurance.

## **11.1.6 BUILDER’S RISK/“ALL RISK” INSURANCE**

### **11.1.6.1 COURSE-OF-CONSTRUCTION INSURANCE REQUIREMENTS**

Unless provided by Owner at Owner’s sole discretion, Contractor, during the progress of the Work and until final acceptance of the Work by Owner upon Completion of the entire Contract, shall maintain Builder’s Risk/Course-of-Construction insurance satisfactory to the Owner, issued on a completed value basis on all insurable Work included under the Contract Documents. This insurance shall insure against all risks, including but not limited to the following perils: Vandalism, theft, malicious mischief, fire, sprinkler leakage, civil authority, sonic boom, explosion, collapse, flood including tidal wave (however, for projects not solely funded through revenue bonds, Contractor is only required to provide insurance for damages caused by a tidal wave up to 5% of the Contract Sum [except as provided in Section 11.1.6.2, below; see Public Contract Code §7105(a)]), earthquake (however, for projects not solely funded through revenue bonds, Contractor is only required to provide insurance for damages caused by an earthquake above 3.5 magnitude on the Richter Scale up to 5% of the Contract Sum [except as provided in Section 11.1.6.3, below; see Public Contract Code §7105(a)]), wind, hail, lightning, smoke, riot or civil commotion, debris removal (including demolition) and reasonable compensation for the Architect’s services and expenses required as a result of such insured loss. This insurance shall provide coverage in an amount not less than the full cost to repair, replace or reconstruct the Work. Such insurance shall include the Owner, the Architect, and any other person or entity with an insurable interest in the Work as an additional named insured.

The Contractor shall submit to the Owner for its approval all items deemed to be uninsurable under the Builder’s Risk/Course-of-Construction insurance. The risk of the damage to the Work due to the perils covered by the Builder’s Risk/Course-of-Construction insurance, as well as any other hazard which might result in damage to the Work, is that of the Contractor and the surety, and no claims for such loss or damage shall be recognized by the Owner, nor will such loss or damage excuse the Complete and satisfactory performance of the Contract by the Contractor.

### **11.1.6.2 TIDAL WAVE INSURANCE**

If the Contract is not solely funded through revenue bonds and Owner accepts an alternate bid by Contractor for insurance coverage for a tidal wave, Contractor shall maintain, in effect during the Work and until final acceptance of the Work by Owner upon Completion of the entire Contract, insurance providing coverage for loss, destruction or damage arising out of or caused by tidal wave and other similar acts of God. This insurance shall provide coverage in an amount not less than the full cost to repair, replace or reconstruct the Work.

### **11.1.6.3 EARTHQUAKE INSURANCE**

If the Contract is not solely funded through revenue bonds and Owner accepts an alternate bid by Contractor for insurance coverage for an earthquake over 3.5 on the Richter Scale, Contractor shall maintain, in effect during the Work and until final acceptance of the Work by Owner upon Completion of the entire Contract, insurance providing coverage for loss, destruction or damage

arising out of or caused by earthquake and/or other earth movement, whether seismic or volcanic in origin, over 3.5 on the Richter Scale in magnitude. This insurance shall provide coverage in an amount not less than the full cost to repair, replace or reconstruct the Work.

#### **11.1.7 CONSENT OF INSURER FOR PARTIAL OCCUPANCY OR USE**

Partial occupancy or use in accordance with the Contract Documents shall not commence until the insurance company providing property insurance has consented to such partial occupancy or use by endorsement or otherwise. The Owner and the Contractor shall take reasonable steps to obtain consent of the insurance company and shall, without mutual consent, take no action with respect to partial occupancy or use that would cause cancellation, lapse, or reduction of the insurance.

#### **11.1.8 FIRE INSURANCE**

Before the commencement of the Work, the Contractor shall procure, maintain, and cause to be maintained at the Contractor's expense, fire insurance on all Work included under the Contract Documents, insuring the full replacement value of such Work as well as the cost of any removal and demolition necessary to replace or repair all Work damaged by fire. The amount of fire insurance shall be subject to approval by the Owner and shall be sufficient to protect the Work against loss or damage in full until the Work is accepted by the Owner. Should the Work being constructed be damaged by fire or other causes during construction, it shall be replaced in accordance with the requirements of the drawings and specifications without additional expense to the Owner.

#### **11.1.9 OTHER INSURANCE**

The Contractor shall provide all other insurance required to be maintained under applicable laws, ordinances, rules, and regulations.

#### **11.1.10 PROOF OF CARRIAGE OF INSURANCE**

The Contractor shall not commence Work nor shall it allow any Subcontractor to commence Work under this Contract until all required insurance, certificates, and an Additional Insured Endorsement and Declarations Page have been obtained and delivered in duplicate to the Owner for approval subject to the following requirements:

- (a) Certificates and insurance policies shall include the following clause:

This policy shall not be non-renewed, canceled, or reduced in required limits of liability or amounts of insurance until notice has been mailed to the Owner. Date of cancellation or reduction may not be less than thirty (30) days after the date of mailing notice.

- (b) Certificates of insurance shall state in particular those insured, the extent of insurance, location and operation to which the insurance applies, the expiration date, and cancellation and reduction notices.
- (c) Certificates of insurance shall clearly state that the Owner and the Architect are named as additional insureds under the policy described and that such insurance policy shall be primary to any insurance or self-insurance maintained by Owner and any other insurance carried by the Owner with respect to the matters covered by such policy shall be excess and non-contributing.
- (d) The Contractor and its Subcontractors shall produce a certified copy of any insurance policy required under this Section upon written request of the Owner.

#### **11.1.11 COMPLIANCE**

In the event of the failure of any contractor to furnish and maintain any insurance required by this Article, the Contractor shall be in default under the Contract. Compliance by Contractor with the requirement to carry insurance and furnish certificates, policies, Additional Insured Endorsement and Declarations Page evidencing the same shall not relieve the Contractor from liability assumed under any provision of the Contract Documents, including, without limitation, the obligation to defend and indemnify the Owner and the Architect.

### **11.2 PERFORMANCE AND PAYMENT BONDS**

#### **11.2.1 BOND REQUIREMENTS**

Unless otherwise specified in the Contract Documents, prior to commencing any portion of the Work, the Contractor shall apply for and furnish Owner separate payment and performance bonds for its portion of the Work which shall cover 100% faithful performance of and payment of all obligations arising under the Contract Documents and/or guaranteeing the payment in full of all claims for labor performed and materials supplied for the Work. All bonds shall be provided by a corporate surety authorized and admitted to transact business in California. All bonds shall be submitted on the Owner's approved form.

To the extent, if any, that the Contract Sum is increased in accordance with the Contract Documents, the Contractor shall cause the amount of the bonds to be increased accordingly and shall promptly deliver satisfactory evidence of such increase to the Owner. To the extent available, the bonds shall further provide that no change or alteration of the Contract Documents (including, without limitation, an increase in the Contract Sum, as referred to above), extensions of time, or modifications of the time, terms, or conditions of payment to the Contractor will release the surety. If the Contractor fails to furnish the required bond, the Owner may terminate the Contract for cause.

#### **11.2.2 SURETY QUALIFICATION**

Only bonds executed by admitted Surety insurers as defined in Code of Civil Procedure

section 995.120 shall be accepted. The surety insurers must, unless otherwise agreed to by Owner in writing, at the time of issuance of the bonds, have a rating not lower than “A-” as rated by A.M. Best Company, Inc. or other independent rating companies. Owner reserves the right to approve or reject the surety insurers selected by Contractor and to require Contractor to obtain bonds from surety insurers satisfactory to the Owner.

## **ARTICLE 12**

### **UNCOVERING AND CORRECTION OF WORK**

#### **12.1 UNCOVERING OF WORK**

##### **12.1.1 UNCOVERING WORK FOR REQUIRED INSPECTIONS**

If a portion of the Work is covered contrary to the Owner’s request or to requirements specifically expressed in the Contract Documents, Contractor must, if required in writing by the Owner, uncover it for the Owner’s observation and replace the removed work at the Contractor’s expense without change in the Contract Sum or Time.

##### **12.1.2 COSTS FOR INSPECTIONS NOT REQUIRED**

If a portion of the Work has been covered which the Owner has not specifically requested to observe prior to its being covered, the Owner may request to see such work, and it shall be uncovered by the Contractor. If such work is in accordance with the Contract Documents, costs of uncover and replacement shall, by appropriate Change Order, be paid by the Owner. If such work is not in accordance with Contract Documents, the Contractor shall pay such costs, unless the condition was caused by the Owner or a separate contractor, in which event the Owner shall be responsible for payment of such costs to the Contractor.

#### **12.2 CORRECTION OF WORK; WARRANTY**

##### **12.2.1 CORRECTION OF REJECTED WORK**

The Contractor shall promptly correct the work rejected by the Owner for failing to conform to the requirements of the Contract Documents, until the statutes of limitation (or repose) and all warranties have run, as applicable, and whether or not fabricated, installed or completed. The Contractor shall bear costs of correcting the rejected work, including additional testing, inspections, and compensation for the Owner’s expenses and costs incurred.

##### **12.2.2 REMOVAL OF NONCONFORMING WORK**

The Contractor shall remove from the Site portions of the Work which are not in accordance with the requirements of the Contract Documents and are not corrected by the Contractor or accepted or approved by the Owner.



### **12.2.3 OWNER'S RIGHTS IF CONTRACTOR FAILS TO CORRECT**

If the Contractor fails to correct nonconforming work within a reasonable time, the Owner may correct it in accordance with Section 2.4. As part of Owner's correction of the work, the Owner may remove any portion of the nonconforming Work and store any salvageable materials or equipment at the Contractor's expense. If the Contractor does not pay costs of such removal and storage within ten (10) days after written notice, the Owner may upon ten (10) additional days written notice sell such material or equipment at auction or at private sale and shall account for the proceeds thereof, after deducting costs and damages that should have been borne by the Contractor, including compensation for the Architect's and other professionals and representatives' services and expenses, made necessary thereby. If such proceeds of sale do not cover costs which the Contractor should have borne, the Contractor shall be invoiced for the deficiency or Owner may withhold such costs from payment pursuant to Section 9.5. If progress payments or retention then or thereafter due the Contractor are not sufficient to cover such amount, the Contractor shall pay the difference to the Owner.

### **12.2.4 COST OF CORRECTING THE WORK**

The Contractor shall bear the cost of correcting destroyed or damaged construction of the Owner or separate contractors, whether completed or partially completed, caused by the Contractor's correction or removal of the nonconforming work.

### **12.2.5 WARRANTY CORRECTIONS (INCLUDES REPLACEMENT)**

Pursuant to the warranty in Section 3.5, if within one (1) year after the Completion of the Work or within a longer time period for an applicable special warranty or guarantee required by the Contract Documents, any of the Work does not comply with the Contract Documents, the Contractor shall correct it after receipt of Owner's written notice to do so, unless the Owner has previously waived in writing such right to demand correction. Contractor shall correct the Work promptly, and passage of the applicable warranty period shall not release Contractor from its obligation to correct the Work if Owner provided the written notice within the applicable warranty period. Contractor's obligation to correct the warranty item continues until the correction is made. After the correction is made to Owner's satisfaction, a new warranty period of the same length as the original warranty period shall run on the corrected work. The obligations under this paragraph 12.2.5 shall survive acceptance of the Work under the Contract and termination of the Contract.

### **12.2.6 NO TIME LIMITATION**

Nothing contained in this Section 12.2 shall be construed to establish a period of limitation with respect to other obligations which the Contractor might have under the Contract Documents. Establishment of the time period of one (1) year as described in Sections 3.5 and 12.2.5 relates only to the specific warranty obligation of the Contractor to correct the Work after the date of commencement of warranties and has, for example, no relationship to the time within which the obligation to comply with the Contract Documents may be sought to be enforced, or to the time within which proceedings may be commenced to establish the Contractor's liability with respect

to the Contractor's obligations other than specifically to correct the Work.

### **12.3 NONCONFORMING WORK AND WITHHOLDING THE VALUE OF IT**

If it is found at any time before Completion of the Work that the Contractor has varied from the Contract Documents in materials, quality, form, finish, or in the amount or value of the materials or labor used, the Owner may, in addition to other remedies in the Contract Documents or under law and as allowed by law, accept the improper Work. The Owner may withhold from any amount due or to become due Contractor that sum of money equivalent to the difference in value between the Work performed and that called for by the Drawings and Specifications. The Owner shall determine such difference in value. No structural related work shall be accepted that is not in conformance with the Contract Documents.

## **ARTICLE 13**

### **MISCELLANEOUS PROVISIONS**

#### **13.1 GOVERNING LAW**

The Contract shall be governed by the law of the place where the Project is located.

#### **13.2 SUCCESSORS AND ASSIGNS**

The Owner and the Contractor respectively bind themselves, their partners, successors, assigns, and legal representatives to the other party hereto and to partners, successors, assigns, and legal representatives of such other party in respect to covenants, agreements, and obligations contained in the Contract Documents. Neither party to the Contract shall assign the Contract as a whole or in part without written consent of the other. If either party attempts to make such an assignment without such consent, that party shall nevertheless remain legally responsible for all obligations under the Contract.

#### **13.3 WRITTEN NOTICE**

In the absence of specific notice requirements in the Contract Documents, written notice shall be deemed to have been duly served if delivered in person to the individual, member of the firm or entity, or to an officer of the corporation for which it was intended, or if delivered at or sent by registered or certified or overnight mail to the last business address known to the party giving notice. Owner shall, at Contractor's cost, timely notify Contractor of Owner's receipt of any third party claims relating to the Contract pursuant to Public Contract Code section 9201.

#### **13.4 RIGHTS AND REMEDIES**

##### **13.4.1 DUTIES AND OBLIGATIONS CUMULATIVE**

Duties and obligations imposed by the Contract Documents and rights and remedies available thereunder shall be in addition to and not a limitation of duties, obligations, rights, and remedies

otherwise imposed or available by law.

#### **13.4.2 NO WAIVER**

No action or failure to act by the Owner, Inspector of Record, Architect or any construction manager shall constitute a waiver of a right or duty afforded them under the Contract Documents, nor shall such action or failure to act constitute approval of or acquiescence in a breach thereunder, except as may be specifically agreed to in a written amendment to the Contract.

### **13.5 TESTS AND INSPECTIONS**

#### **13.5.1 COMPLIANCE**

Tests, inspections, and approvals of portions of the Work required by the Contract Documents will comply with Title 24, and with all other laws, ordinances, rules, regulations, or orders of public authorities having jurisdiction.

#### **13.5.2 INDEPENDENT TESTING LABORATORY**

The Owner will select and pay an independent testing laboratory to conduct all tests and inspections, including shipping or transportation costs or expenses (mileage and hours). Selection of the materials required to be tested shall be made by the laboratory and not by the Contractor. However, if Contractor requests that the Owner use a different testing laboratory and Owner chooses to approve such request, Contractor shall reimburse Owner for any additional shipping or transportation costs or expenses (mileage and hours). Owner may invoice such costs or expenses to the Contractor or withhold such costs or expenses from progress payments and/or retention.

#### **13.5.3 ADVANCE NOTICE TO INSPECTOR OF RECORD**

The Contractor shall notify the Inspector of Record a sufficient time in advance of its readiness for required observation or inspection so that the Inspector of Record may arrange for same. The Contractor shall notify the Inspector of Record a sufficient time in advance of the manufacture of material to be supplied under the Contract Documents which must, by terms of the Contract Documents, be tested in order that the Inspector of Record may arrange for the testing of the material at the source of supply.

#### **13.5.4 TESTING OFF-SITE**

Any material shipped by the Contractor from the source of supply, prior to having satisfactorily passed such testing and inspection or prior to the receipt of notice from said Inspector of Record that such testing and inspection will not be required, shall not be incorporated in the Work.

### **13.5.5 ADDITIONAL TESTING OR INSPECTION**

If the Inspector of Record, the Architect, the Owner, or public authority having jurisdiction determines that portions of the Work require additional testing, inspection, or approval not included under section 13.5.1, the Inspector of Record will, upon written authorization from the Owner, make arrangements for such additional testing, inspection, or approval. The Owner shall bear such costs except as provided in section 13.5.6.

### **13.5.6 COSTS FOR RETESTING**

If such procedures for testing, inspection, or approval under sections 13.5.1, 13.5.2 and 13.5.5 reveal failure of the portions of the Work to comply with requirements established by the Contract Documents, the Contractor shall bear all costs arising from such failure, including those of re-testing, re-inspection, or re-approval, including, but not limited to, compensation for the Architect's services and expenses. Any such costs shall be paid by the Owner, invoiced to the Contractor, and, among other remedies, can be withheld from progress payments and/or retention.

### **13.5.7 COSTS FOR PREMATURE TEST**

In the event the Contractor requests any test or inspection for the Project and is not completely ready for the inspection, the Contractor shall be invoiced by the Owner for all costs and expenses resulting from that testing or inspection, including, but not limited to, the Architect's fees and expenses, and the amount of the invoice can among other remedies, be withheld from progress payments and/or retention.

### **13.5.8 TESTS OR INSPECTIONS NOT TO DELAY WORK**

Tests or inspections conducted pursuant to the Contract Documents shall be made promptly to avoid unreasonable delay in the Work.

## **13.6 [INTENTIONALLY LEFT BLANK]**

## **13.7 TRENCH EXCAVATION**

### **13.7.1 TRENCHES GREATER THAN FIVE FEET**

Pursuant to Labor Code section 6705, if the Contract Sum exceeds \$25,000 and involves the excavation of any trench or trenches five (5) feet or more in depth, the Contractor shall, in advance of excavation, submit to the Owner or a registered civil or structural engineer employed by the Owner a detailed plan showing the design of shoring for protection from the hazard of caving ground during the excavation of such trench or trenches.

### **13.7.2 EXCAVATION SAFETY**

If such plan varies from the Shoring System Standards established by the Construction Safety

Orders, the plan shall be prepared by a registered civil or structural engineer, but in no case shall such plan be less effective than that required by the Construction Safety Orders. No excavation of such trench or trenches shall be commenced until said plan has been accepted by the Owner or by the person to whom authority to accept has been delegated by the Owner.

### **13.7.3 NO TORT LIABILITY OF OWNER**

Pursuant to Labor Code section 6705, nothing in this Article shall impose tort liability upon the Owner or any of its employees.

### **13.7.4 NO EXCAVATION WITHOUT PERMITS**

The Contractor shall not commence any excavation work until it has secured all necessary permits including the required CAL OSHA excavation/shoring permit. Any permits shall be prominently displayed on the Site prior to the commencement of any excavation.

## **13.8 WAGE RATES**

### **13.8.1 WAGE RATES**

Pursuant to the provisions of Article 2 (commencing at § 1770), Chapter 1, Part 7, Division 2, of the Labor Code, the governing board of the Owner has obtained the general prevailing rate of per diem wages and the general prevailing rate for holiday and overtime work in the locality in which this public work is to be performed for each craft, classification, or type of worker needed for this Project from the Director of Industrial Relations (“Director”). These rates are on file with the Clerk of the Owner’s Governing Board, and copies will be made available to any interested party on request. The Contractor shall post a copy of such wage rates at the Site.

### **13.8.2 HOLIDAY AND OVERTIME PAY**

Holiday and overtime work, when permitted by law, shall be paid for at a rate of at least one and one-half (1½) times the above specified rate of per diem wages, unless otherwise specified. Holidays shall be defined in the Collective Bargaining Agreement applicable to each particular craft, classification, or type of worker employed.

### **13.8.3 WAGE RATES NOT AFFECTED BY SUBCONTRACTS**

The Contractor shall pay and shall cause to be paid each worker engaged in the Work on the Project not less than the general prevailing rate of per diem wages determined by the Director, regardless of any contractual relationship which may be alleged to exist between the Contractor or any Subcontractor and such workers.

### **13.8.4 CHANGE IN PREVAILING WAGE DURING BID OR CONSTRUCTION**

If during the period this bid is required to remain open, the Director of Industrial Relations

determines that there has been a change in any prevailing rate of per diem wages in the locality in which this public work is to be performed, such change shall not alter the wage rates discussed in the Notice to Bidders or the Contract subsequently awarded.

#### **13.8.5 FORFEITURE AND PAYMENTS**

Pursuant to Labor Code section 1775, the Contractor and any subcontractor under the Contractor shall as a penalty to the Owner, forfeit not more than Two Hundred Dollars (\$200.00) for each calendar day, or portion thereof, for each worker paid less than the prevailing rate of per diem wages, determined by the Director, for such craft or classification in which such worker is employed for any public work done under the Agreement by the Contractor or by any Subcontractor under it. Minimum penalties shall apply, as also provided in Civil Code section 1775. The amount of the penalty shall be determined by the Labor Commissioner and shall be based on both of the following: (1) whether the failure of the contractor or subcontractor to pay the correct rate of per diem wages was a good faith mistake and, if so, the error was promptly and voluntarily corrected upon being brought to the attention of the contractor or subcontractor; and (2) whether the contractor or subcontractor has a prior record of failing to meet its prevailing wage obligations. The difference between such prevailing rate of per diem wage and the amount paid to each worker for each calendar day or portion thereof for which each worker was paid less than the prevailing rate of per diem wage shall be paid to each work by the Contractor or subcontractor. Labor Code section 1777.1 shall also apply.

#### **13.8.6 MINIMUM WAGE RATES**

Any worker employed to perform Work on the Contract, which Work is not covered by any craft or classification listed in the general prevailing rate of per diem wages determined by the Director, shall be paid not less than the minimum rate of wages specified therein for the craft or classification which most nearly corresponds to the Work to be performed by them, and such minimum wage rate shall be retroactive to time of initial employment of such person in such craft or classification.

#### **13.8.7 PER DIEM WAGES**

Pursuant to Labor Code section 1773.1, per diem wages includes employer payments for health and welfare, pension, and vacation pay.

#### **13.8.8 POSTING OF WAGE RATES AND OTHER REQUIRED JOB SITE NOTICES**

The Contractor shall post at appropriate conspicuous points on the Site, a schedule showing all determined minimum wage rates and all authorized deductions, if any, from unpaid wages actually earned and all other required job site notices as prescribed by regulation.

## 13.9 RECORD OF WAGES PAID: INSPECTION

### 13.9.1 APPLICATION OF LABOR CODE

Pursuant to section 1776 of the Labor Code:

(a) Each Contractor and subcontractor shall keep accurate payroll records, showing the name, address, social security number, work classification, and straight time and overtime hours worked each day and week, and the actual per diem wages paid to each journeyman, apprentice, worker, or other employee employed by him or her in connection with the public work. Each payroll record shall contain or be verified by a written declaration that is made under penalty of perjury, stating both of the following:

- (1) The information contained in the payroll record is true and correct.
- (2) The employer has complied with the requirements of sections 1771, 1811 and 1815 for any work performed by his or her employees on the public works project.

(b) The payroll records enumerated under subdivision (a) shall be certified and shall be available for inspection at all reasonable hours at the principal office of the Contractor on the following basis:

(1) A certified copy of an employee's payroll record shall be made available for inspection or furnished to the employee or his or her authorized representative on request.

(2) A certified copy of all payroll records enumerated in subdivision (a) shall be made available for inspection or furnished upon request to a representative of the Owner and the Division of Labor Standards Enforcement of the Department of Industrial Relations ("DIR") and as may be required by the Labor Commissioner under Labor Code section 1771.4). The Contractor and each subcontractor shall furnish a certified copy of all payroll records directly to the Labor Commissioner monthly or more frequently, if so specified in the Agreement and in a format the Labor Commissioner prescribes.

(3) A certified copy of all payroll records enumerated in subdivision (a) shall be made available upon request by the public for inspection or for copies thereof. However, a request by the public shall be made through either the body awarding the contract or the Division of Labor Standards Enforcement of the ... (DIR). If the requested payroll records have not been provided pursuant to paragraph (2), the requesting party shall, prior to being provided the records, reimburse the costs of the preparation by the contractor, subcontractors, and the entity through which the request was made. The public may not be given access to such records at the principal office of the Contractor.

(c) Unless required as of January 1, 2015, to be furnished directly to the Labor Commissioner under Labor Code section 1771.4(a)(3), the certified payroll records shall be on forms provided by the Division of Labor Standards Enforcement (of the DIR) or shall contain the same information as the forms provided by the division. The payroll records may consist of printouts of payroll data that are maintained as computer records, if the printouts contain the same information as the forms provided by the division and the printouts are verified in the manner specified in (a) above.

(d) A Contractor or subcontractor shall file a certified copy of the records enumerated in subdivision (a) with the entity that requested such records within 10 days after receipt of a written request.

(e) Except as provided in subdivision (f), any copy of records made available for inspection as copies and furnished upon request to the public or any public agency by the awarding body or the Division of Labor Standards Enforcement (of the DIR) shall be marked or obliterated to prevent disclosure of an individual's name, address and social security number. The name and address of the Contractor awarded the Contract or the subcontractor performing the Contract shall not be marked or obliterated. Any copy of records made available for inspection by, or furnished to, a multiemployer Taft-Hartley trust fund (29 U.S.C. Sec. 186(c)(5) that requests the records for the purposes of allocating contributions to participants shall be marked or obliterated only to prevent disclosure of an individual's full social security number, but shall provide the last four digits of the social security number. Any copy of records made available for inspection by, or furnished to, a joint labor-management committee established pursuant to the federal Labor Management Cooperation Act of 1978 (29 U.S.C. Sec. 175a) shall be marked or obliterated only to prevent disclosure of an individual's social security number.

(f) Notwithstanding any other provision of law, agencies that are included in the Joint Enforcement Strike Force on the Underground Economy established pursuant to Section 329 of the Unemployment Insurance Code and other law enforcement agencies investigating violations of law shall, upon request, be provided nonredacted copies of certified payroll records. Any copies of records or certified payroll made available for inspection and furnished upon request to the public by an agency included in the Joint Enforcement Strike Force on the Underground Economy or to a law enforcement agency investigating a violation of law shall be marked or redacted to prevent disclosure of an individual's name, address, and social security number. An employer shall not be liable for damages in a civil action for any reasonable act or omission taken in good faith in compliance with this subsection.

(g) The contractor shall inform the body awarding the contract of the location of the records enumerated under subdivision (a), including the street address, city and county, and shall, within five working days, provide a notice of a change of location and address.

(h) The contractor or subcontractor has 10 days in which to comply subsequent to



receipt of written notice requesting the records enumerated in subdivision (a). In the event that the Contractor or subcontractor fails to comply within the 10-day period, he or she shall, as a penalty to the state or political subdivision on whose behalf the contract is made or awarded, forfeit One Hundred Dollars (\$100.00) for each calendar day, or portion thereof, for each worker, until strict compliance is effectuated. Upon the request of the Division of Labor Standards Enforcement (of the DIR), these penalties shall be withheld from progress payments then due. A contractor is not subject to a penalty assessment pursuant to this section due to the failure of the subcontractor to comply with this section.

## **13.10 APPRENTICES**

### **13.10.1 APPRENTICE WAGES AND DEFINITIONS**

All apprentices employed by the Contractor to perform services under the Contract shall be paid the standard wage paid to apprentices under the regulations of the craft or trade at which he or she is employed, and shall be employed only at the work of the craft or trade to which he or she is registered. Only apprentices, as defined in section 3077 of the Labor Code, who are in training under apprenticeship standards and written apprenticeship agreements under Chapter 4 (commencing with § 3070) of Division 3, are eligible to be employed under this Contract. The employment and training of each apprentice shall be in accordance with the apprenticeship standards and apprentice agreements under which he or she is training. Contractor shall pay apprentices for any preemployment activities, as set forth in Labor Code section 1777.5.

### **13.10.2 APPRENTICE LABOR POOL**

When the Contractor to whom the Contract is awarded by the Owner, or any Subcontractor under him or her, in performing any of the Work under the Contract or subcontract, employs workers in any apprenticeable craft or trade, the Contractor and Subcontractor shall apply to the joint apprenticeship committee administering the apprenticeship standards of the craft or trade in the area of the Site of the Project, for a certificate approving the Contractor or Subcontractor under the apprenticeship standards for the employment and training of apprentices in the area or industry affected. However, approval as established by the joint apprenticeship committee or committees shall be subject to the approval of the Administrator of Apprenticeship. The joint apprenticeship committee or committees, subsequent to approving the subject Contractor or Subcontractor, shall arrange for the dispatch of apprentices to the Contractor or Subcontractor in order to comply with this section. Every Contractor and Subcontractor shall submit the contract award information to the applicable joint apprenticeship committee which shall include an estimate of journeyman hours to be performed under the Contract, the number of apprentices to be employed, and the approximate dates the apprentices will be employed. There shall be an affirmative duty upon the joint apprenticeship committee or committees administering the apprenticeship standards of the crafts or trade in the area of the Site of the public work, to ensure equal employment and affirmative action and apprenticeship for women and minorities. Contractors or Subcontractors shall not be required to submit individual applications for approval to local joint apprenticeship committees provided they are already covered by the local apprenticeship standards. The ratio of work performed by apprentices to journeymen, who shall

be employed in the craft or trade on the Project, may be the ratio stipulated in the apprenticeship standards under which the joint apprenticeship committee operates, but, except as otherwise provided in this section, in no case shall the ratio be less than one (1) hour of apprentice work for every five (5) hours of labor performed by a journeyman. However, the minimum ratio for the land surveyor classification shall not be less than one (1) apprentice for each five (5) journeymen.

### 13.10.3 JOURNEYMAN/APPRENTICE RATIO; COMPUTATION OF HOURS

Any ratio shall apply during any day or portion of a day when any journeyman, or the higher standard stipulated by the joint apprenticeship committee, is employed at the job Site and shall be computed on the basis of the hours worked during the day by journeymen so employed, except for the land surveyor classification. The Contractor shall employ apprentices for the number of hours computed as above before the end of the Contract. However, the Contractor shall endeavor, to the greatest extent possible, to employ apprentices during the same time period that the journeymen in the same craft or trade are employed at the job Site. Where an hourly apprenticeship ratio is not feasible for a particular craft or trade, the Division of Apprenticeship Standards, upon application of a joint apprenticeship committee, may order a minimum ratio of not less than one (1) apprentice for each five (5) journeymen in a craft or trade classification.

### 13.10.4 JOURNEYMAN/APPRENTICE RATIO

The Contractor or Subcontractor, if he or she is covered by this section upon the issuance of the approval certificate, or if he or she has been previously approved in the craft or trade, shall employ the number of apprentices or the ratio of apprentices to journeymen stipulated in the apprenticeship standards. Upon proper showing by the Contractor that he or she employs apprentices in the craft or trade in the state on all of his or her contracts on an annual average of not less than one (1) hour of apprentice work for every five (5) hours of labor performed by a journeyman, or in the land surveyor classification, one (1) apprentice for each five (5) journeymen, the Division of Apprenticeship Standards may grant a certificate exempting the Contractor from the 1-to-5 hourly ratio as set forth in this section. This section shall not apply to contracts of general contractors or to contracts of specialty contractors not bidding for work through a general or prime contractor, when the contracts of general contractors or those specialty contractors involve less than Thirty Thousand Dollars (\$30,000) or twenty (20) working days. Any work performed by a journeyman in excess of eight (8) hours per day or forty (40) hours per week, shall not be used to calculate the hourly ratio required by this section.

13.10.4.1 *Apprenticeable Craft or Trade.* “Apprenticeable craft or trade” as used in this Article means a craft or trade determined as an apprenticeable occupation in accordance with the rules and regulations prescribed by the California Apprenticeship Council. The joint apprenticeship committee shall have the discretion to grant a certificate, which shall be subject to the approval of the Administrator of Apprenticeship, exempting a Contractor from the 1-to-5 ratio set forth in this Article when it finds that any one of the following conditions is met:

- A. Unemployment for the previous three-month period in the area exceeds an average of fifteen percent (15%).

- B. The number of apprentices in training in such area exceeds a ratio of 1-to-5.
- C. There is a showing that the apprenticeable craft or trade is replacing at least one-thirtieth (1/30) of its journeymen annually through the apprenticeship training, either on a statewide basis or on a local basis.
- D. Assignment of an apprentice to any work performed under this contract would create a condition which would jeopardize his or her life or the life, safety, or property of fellow employees or the public at large or if the specific task to which the apprentice is to be assigned is of such a nature that training cannot be provided by a journeyman.

#### 13.10.5 **RATIO EXEMPTION**

When exemptions are granted to an organization which represents Contractors in a specific trade from the 1-to-5 ratio on a local or statewide basis, the member Contractors will not be required to submit individual applications for approval to local joint apprenticeship committees, if they are already covered by the local apprenticeship standards.

#### 13.10.6 **APPRENTICE FUND**

A Contractor to whom the Contract is awarded or any Subcontractor under him or her, who, in performing any of the work under the Contract, employs journeymen or apprentices in any apprenticeable craft or trade and who is not contributing to a fund or funds to administer and conduct the apprenticeship program in any such craft or trade in the area of the Site of the Project, to which fund or funds other contractors in the area of the Site of the Project are contributing, shall contribute to the fund or funds in each craft or trade in which he or she employs journeymen or apprentices on the Project in the same amount or upon the same basis and in the same manner as the other contractors do, but where the trust fund administrators are unable to accept the funds, contractors not signatory to the trust agreement shall pay a like amount to the California Apprenticeship Council. The Contractor or Subcontractor may add the amount of the contributions in computing his or her bid for the contract. The Division of Labor Standards Enforcement is authorized to enforce the payment of the contributions to the fund or funds as set forth in the Labor Code section 227.

#### 13.10.7 **PRIME CONTRACTOR COMPLIANCE**

The responsibility of compliance with section 13.10 and section 1777.5 of the Labor Code for all apprenticeable occupations is with the Prime Contractor.

#### 13.10.8 **DECISIONS OF JOINT APPRENTICESHIP COMMITTEE**

All decisions of the joint apprenticeship committee under this section 13.10 and Labor Code section 1777.5 are subject to Labor Code section 3081.

### 13.10.9 NO BIAS

It shall be unlawful for an employer or a labor union to refuse to accept otherwise qualified employees as registered apprentices on any public works on the grounds of race, religious creed, color, national origin, ancestry, sex, or age, except as provided in the Labor Code section 3077.

### 13.10.10 VIOLATION OF LABOR CODE

Pursuant to Labor Code sections 1777.1 and 1777.7, in the event a Contractor or Subcontractor fails to comply with the provisions of this section 13.10 and Labor Code section 1777.5, among other things:

- (a) If a Contractor or Subcontractor willfully fails to comply, the Labor Commissioner may deny to the contractor or subcontractor, and to its responsible officers, the right to bid on, or be awarded or perform work as a subcontractor on, any public works project for a period of up to one year for the first violation and for a period of up to three years for the second and subsequent violation. Each period of debarment shall run from the date the determination of noncompliance by the Labor Commissioner becomes a final order.
- (b) A contractor or subcontractor who violates section 1777.5 shall forfeit as a civil penalty an amount not exceeding the sum of One Hundred Dollars (\$100) for each full calendar day of noncompliance. Upon receipt of a determination that a civil penalty has been imposed, the awarding body shall enforce the penalty, which includes withholding the amount of the civil penalty from the contract progress payments or retention then due or to become due.
- (c) In lieu of the penalty provided, the Labor Commissioner may for a first time violation and with the concurrence of an applicable apprenticeship program, order the contractor or subcontractor to provide apprentice employment equivalent to the work hours that would have been provided for apprentices during the period of noncompliance.
- (d) Any funds withheld by the awarding body pursuant to this section shall be deposited in the General Fund.
- (e) The interpretation and enforcement of section 1777.5 and this section shall be in accordance with the regulations of the California Apprenticeship Council.

Pursuant to Public Contract Code section 6109, no contractor or subcontractor may bid on, be awarded, or perform work as a subcontractor on a public works project if ineligible to bid or work on, or be awarded, a public works project pursuant to section 1777.1 of the Labor Code.

## **13.11 ASSIGNMENT OF ANTITRUST CLAIMS**

### **13.11.1 APPLICATION**

Pursuant to Public Contract Code section 7103.5 and Government Code section 4552, in entering into a public works contract or a subcontract to supply goods, services, or materials pursuant to a public works contract, the Contractor or Subcontractor offers and agrees to assign to the Owner all rights, title, and interest in and to all causes of action it may have under Section 4 of the Clayton Act, (15 U.S.C. § 15) or under the Cartwright Act (Chapter 2 [commencing with § 16700] of Part 2 of Division 7 of the Bus. & Prof. Code), arising from the purchase of goods, services, or materials pursuant to the public works contract or the subcontract. This assignment shall be made and become effective at the time the awarding body tenders Final Progress Payment to the Contractor, without further acknowledgment by the parties. If the Owner receives, either through judgment or settlement, a monetary recovery for a cause of action assigned under Chapter 11 (commencing with § 4550) of Division 5 of Title 1 of the Government Code, the assignor may, upon demand, recover from the Owner any portion of the recovery, including treble damages, attributable to overcharges that were paid by the assignor but were not paid by the Owner as part of the bid price, less the expenses incurred in obtaining that portion of the recovery.

### **13.11.2 ASSIGNMENT OF CLAIM**

Upon demand in writing by the assignor, the Owner shall, within one (1) year from such demand, reassign the cause of action assigned pursuant to this Article if the assignor has been or may have been injured by the violation of law for which the cause of action arose and the Owner has not been injured thereby or the Owner declines to file a court action for the cause of action.

## **13.12 AUDIT**

Pursuant to and in accordance with the provisions of Government Code section 8546.7, or any amendments thereto, all books, records, and files of the Owner, the Contractor, or any Subcontractor connected with the performance of this Contract involving the expenditure of state funds in excess of Ten Thousand Dollars (\$10,000.00), including, but not limited to, the administration thereof, shall be subject to the examination and audit of the Office of the Auditor General of the State of California for a period of three (3) years after release of all retention under this Contract. Contractor shall preserve and cause to be preserved such books, records, and files for the audit period. During the progress of the Work and for three (3) years after release of all retention under the Contract, Owner shall also have the right to an audit of Contractor's books, records, subcontracts, material and equipment contracts, files, and information related to the project, and Contractor must cooperate by producing all requested items within seven (7) days.

## **13.13 STORM WATER DISCHARGE PERMIT**

If applicable, the Contractor shall file a Notice of Intent to comply with the terms of the general permit to discharge storm water associated with construction activity (WQ Order No. 920-08-

DWQ). The Notice of Intent must be sent to the following address along with the appropriate payment (warrant to be furnished by the Owner upon request by the Contractor, allow warrant processing time.): California State Water Resources Control Board, Division of Water Quality, Storm Water Permit Unit, P.O. Box 1977, Sacramento, CA 95812-1977. The Contractor may also call the State Water Board's Construction Activity Storm Water Hotline at (916) 657-1146. The Notice of Intent shall be filed prior to the start of any construction activity.

## **ARTICLE 14**

### **TERMINATION OR SUSPENSION OF THE CONTRACT**

#### **14.1 TERMINATION BY THE CONTRACTOR FOR CAUSE**

Contractor may not terminate performance for convenience. Contractor may only terminate performance for cause if the Work is stopped by others for a period of one hundred eighty (180) consecutive days through no act or fault of the Contractor, a Subcontractor of any tier, their agents or employees, or any other persons performing portions of the Work for whom the Contractor is contractually responsible, **and** the Work was stopped by others for one of the following reasons: (A) Issuance of an order of a court or other public authority having jurisdiction which requires Owner to stop all Work; or (B) an act of government, such as a declaration of national emergency, making material unavailable which requires Owner to stop all Work. If such grounds exist, the Contractor may serve written notice of such grounds on Owner and demand a meet-and-confer conference to negotiate a resolution in good faith within twenty (20) days of Owner's receipt of such notice. If such conference does not lead to resolution and the grounds for termination still exist, Contractor may terminate the Contract and recover from the Owner payment for Work executed and for reasonable verified costs with respect to materials, equipment, tools, construction equipment, and machinery, including reasonable overhead, profit, and damages for the Work executed, but excluding overhead (field and home office) and profit for (i) Work not performed and (ii) the period of time that the Work was stopped.

#### **14.2 TERMINATION BY THE OWNER FOR CAUSE**

##### **14.2.1 GROUNDS FOR TERMINATION**

The Owner may terminate performance of the Contract if the Contractor:

- A. Refuses or fails to supply enough properly skilled workers or proper materials, or refuses or fails to take steps to adequately prosecute the Work to meet a Milestone Deadline or to Complete within the Contract Time;
- B. Fails to make payment to Subcontractors for materials or labor in accordance with Public Contract Code section 10262 or Business and Professions Code section 7108.5, as applicable;
- C. Violates Labor Code section 1771.1(a), subject to the provisions of Labor Code

section 1771.1(f);

- D. Disregards laws, ordinances, rules, regulations, or orders of a public authority having jurisdiction; or
- E. Otherwise is in breach of the Contract Documents.

#### 14.2.2 NOTIFICATION OF TERMINATION

When any of the above reasons exist, the Owner may, without prejudice to any other rights or remedies of the Owner, give notice to Contractor of the grounds for termination and demand cure of the grounds within seven (7) days (a “Notice of Intent to Terminate”). If Contractor fails to **either** (a) completely cure the grounds for termination within seven (7) days **or** (b) reasonably commence cure of the grounds for termination within seven (7) days and reasonably continue to cure the grounds for termination until such cure is complete, then Owner may terminate the performance of Contract effective immediately upon service of written Notice of Termination and may, subject to any prior rights of Contractor’s surety on the performance bond (“Surety”):

- A. Take possession of the Site and of all material, equipment, tools, and construction equipment and machinery thereon owned by the Contractor;
- B. Accept assignment of subcontracts pursuant to section 5.4; and
- C. Complete the Work by whatever reasonable method the Owner may deem expedient, including tender of completion to the Surety.

#### 14.2.3 PAYMENTS WITHHELD

If the Owner terminates performance of the Contract for one of the reasons stated in section 14.2.1, the Contractor shall not be entitled to receive further payment until the Work is Complete.

#### 14.2.4 PAYMENTS UPON COMPLETION

If the unpaid balance of the Contract Sum exceeds costs of Completing the Work, including compensation for professional services and expenses made necessary thereby, such excess shall be paid to the Contractor. If such costs exceed the unpaid balance, the Contractor shall pay the difference to the Owner. This payment obligation shall survive Completion of the Work.

#### 14.2.5 INCLUSION OF TERMINATION FOR CONVENIENCE

Any purported termination by Owner for cause under this section 14.2, which is revoked or determined to not have been for cause, shall be deemed to have been a termination for convenience effective as of the same date as the purported termination for cause.

## 14.3 SUSPENSION OR TERMINATION BY THE OWNER FOR CONVENIENCE

### 14.3.1 SUSPENSION BY OWNER

The Owner may, without cause, order the Contractor in writing to suspend, delay, or interrupt the Work in whole or in part for such period of time as the Owner may determine.

14.3.1.1 *Adjustments.* An adjustment shall be made for increases in the cost of performance of the Contract, including profit on the increased cost of performance caused by suspension, delay, or interruption. No adjustment shall be made to the extent:

- A. That performance is, was or would have been so suspended, delayed, or interrupted by another cause for which the Contractor is responsible; or
- B. That an equitable adjustment is made or denied under another provision of this Contract.

14.3.1.2 *Adjustments for Fixed Cost.* Adjustments made in the cost of performance may have a mutually agreed fixed or percentage fee.

### 14.3.2 TERMINATION BY THE OWNER FOR CONVENIENCE

14.3.2.1 The Owner may, at any time, terminate performance of the Contract for the Owner's convenience and without cause.

14.3.2.2 Upon receipt of written notice from the Owner of such termination for the Owner's convenience, the Contractor shall:

1. Cease operations as directed by the Owner in the notice;
2. Take actions necessary, or that the Owner may direct, for the protection and preservation of the Work; and
3. Except for Work directed to be performed prior to the effective date of termination stated in the notice, terminate all existing subcontracts and purchase orders and enter into no further subcontracts and purchase orders.

14.3.2.3 In case of such termination for the Owner's convenience, the Contractor shall be entitled to receive payment for Work executed, and costs incurred by reason of such termination.

## 14.4 NOT A WAIVER

Any suspension or termination by Owner of performance by Contractor for convenience or cause under this Article 14 shall not act as a waiver of any claims by Owner against Contractor or



others for damages based on breach of contract, negligence or other grounds.

#### **14.5 MUTUAL TERMINATION FOR CONVENIENCE**

The Contractor and the Owner may mutually agree in writing to terminate performance of this Contract for convenience. The Contractor shall receive payment for all Work performed to the date of termination in accordance with the provisions of Article 9.

#### **14.6 EARLY TERMINATION**

Notwithstanding any provision herein to the contrary, if for any fiscal year of this Contract the governing body of the Owner fails to appropriate or allocate funds for future periodic payments under the Contract after exercising reasonable efforts to do so, the Owner may upon thirty (30) days' notice, order Work on the Project to cease. The Owner will remain obligated to pay for the Work already performed but shall not be obligated to pay the balance remaining unpaid beyond the fiscal period for which funds have been appropriated or allocated and for which the Work has not been done.

**AGREEMENT BETWEEN OWNER AND CONTRACTOR**

This Agreement between Owner and Contractor (the “Agreement”) is effective **April 18, 2024** between **Antelope Valley Union High School District** (the “Owner”) and \_\_\_\_\_ (the “Contractor”), each a “Party” and together, the “Parties” to this Agreement.

**WITNESSETH:** That the Contractor and the Owner for the consideration hereinafter named agree as follows:

**ARTICLE I. SCOPE OF WORK.** The Contractor agrees to furnish all labor, equipment and materials, including tools, implements, and appliances required, and to perform all the Work in a good and workmanlike manner, free from any and all liens and claims from mechanics, material suppliers, subcontractors, artisans, machinists, teamsters, freight carriers, and laborers required for:

**Bid# 15/23-24 Desert Winds, Eastside, and R. Rex Parris High Schools Re-Roofs**

all in strict compliance with the plans, drawings and specifications therefore prepared by:

**National Roofing Consultants, Inc. (NRC)  
118 Lincoln Avenue  
Pomona, CA 91767  
(909) 620-0177  
(909) 620-6068 Fax**

and other Contract Documents relating thereto.

During the Work, the Contractor shall ensure that all Work, including but not limited to Work performed by Subcontractors, is performed in compliance with all applicable legal, contractual, and local government requirements related to the novel coronavirus and COVID-19, including “social distancing,” masks, and hygiene as may be ordered by the State or local authorities and as may be directed in the Contract Documents.

**ARTICLE II. CONTRACT DOCUMENTS.** The Contractor and the Owner agree that all of the documents listed in Article 1.1.1 of the General Conditions form the Contract Documents which form the Contract.

**ARTICLE III. TIME TO COMPLETE AND LIQUIDATED DAMAGES.** Time is of the essence in this Contract, and the time of Completion for the Work (“the Contract Time”) shall be **NINETY (90)** calendar days which shall start to run on (a) the date of commencement of the Work as established in the Owner’s Notice to Proceed, or (b) if no date of commencement is established in a Notice to Proceed from Owner, the date of Contractor’s actual commencement of the Work (including mobilization).

Failure to Complete the Work within the Contract Time and in the manner provided for by the Contract Documents, or failure to complete any specified portion of the Work by a milestone deadline, shall subject the Contractor to liquidated damages. The actual occurrence of damages and the actual amount of the damages which the Owner would suffer if the Work were not Completed within the Contract Time, or if any specified portion of the Work were not completed by a milestone deadline, are dependent upon many circumstances and conditions which could prevail in various combinations and, from the nature of the case, it is impracticable and extremely difficult to fix the actual damages. Damages which the Owner would suffer in the event of such delay include, but are not limited to, loss of the use of the Work, disruption of activities, costs of administration and supervision, third party claims, and the incalculable inconvenience and loss suffered by the public.

Accordingly, the parties agree that \$500.00 per calendar day of delay shall be the damages which the Owner shall directly incur upon failure of the Contractor to Complete the Work within the Contract Time or Complete any specified portion of the Work by a milestone deadline, as described above. Liquidated damages will accrue for failure to meet milestone deadlines even if the Contractor Completes the Work within the Contract Time.

In addition, Contractor shall be subject to liquidated damages, or actual damages if liquidated damages are not recoverable under law, for causing another contractor on the Project to fail to timely complete its work under its contract or for causing delayed *completion* of the Project. The actual occurrence of damages and the actual amount of the damages which the Owner would suffer if another contractor on the Project were to fail to timely complete its work under its contract or delay *completion* of the Project are dependent upon many circumstances and conditions which could prevail in various combinations and, from the nature of the case, it is impracticable and extremely difficult to fix the actual damages. Damages which the Owner would suffer in the event of such delay include, but are not limited to, loss of the use of the Work, loss of use of the other contractor's work, loss of use of the Project, disruption of activities, costs of administration and supervision, third party claims, the incalculable inconvenience and loss suffered by the public, and an Owner's inability to recover its delay damages from the contractors whose work was delayed by Contractor.

Accordingly, the parties agree that **\$500.00** for each calendar day of delay shall be the amount of damages which the Owner shall directly incur upon Contractor causing another contractor on the Project to fail to timely complete its work under its contract or causing delayed *completion* of the Project.

For Contractor's obligations regarding claims against Owner from other contractors on the Project alleging that Contractor caused delays to their work, see General Conditions sections 3.7.4, 3.16 and 6.2.3.

If liquidated damages accrue as described above, the Owner, in addition to all other remedies provided by law, shall have the right to assess the liquidated damages at any time, and to withhold liquidated damages (and any interest thereon) at any time from any and all retention or progress payments, which would otherwise be or become due the Contractor. In addition, if it is reasonably apparent to the Owner before liquidated damages begin to accrue that they will accrue,

Owner may assess and withhold, from retention or progress payments, the estimated amount of liquidated damages that will accrue in the future. If the retained percentage or withheld progress payments are not sufficient to discharge all liabilities of the Contractor incurred under this Article, the Contractor and its sureties shall continue to remain liable to the Owner until all such liabilities are satisfied in full.

If Owner accepts any work or makes any payment under the Contract Documents after a default by reason of delays, the payment or payments shall in no respect constitute a waiver or modification of any provision in the Contract Documents regarding time of Completion, milestone deadlines, or liquidated damages.

**ARTICLE IV. PAYMENT AND RETENTION.** The Owner agrees to pay the Contractor in current funds \_\_\_\_\_ Dollars (\$\_\_\_\_\_) for work satisfactorily performed after receipt of properly documented and submitted Applications for Payment and to make payments on account thereof, as provided in the General Conditions.

“The above contract price does not include any special allowances.”

**ARTICLE V. CHANGES.** Changes in this Agreement or in the Work to be done under this Agreement shall be made as provided in the General Conditions.

**ARTICLE VI. TERMINATION.** The Owner or Contractor may terminate the Contract as provided in the General Conditions.

**ARTICLE VII. PREVAILING WAGES.** The Project is a public work, the Work shall be performed as a public work and pursuant to the provisions of Section 1770 et seq. of the Labor Code of the State of California, which are hereby incorporated by reference and made a part hereof, the Director of Industrial Relations has determined the general prevailing rate of per diem wages and the general prevailing rate for holiday and overtime work in the locality in which the Work is to be performed, for each craft, classification or type of worker needed to execute this Contract. Per diem wages shall be deemed to include employer payments for health and welfare, pension, vacation, apprenticeship or other training programs, and similar purposes. Copies of the rates are on file at the Owner’s principal office. The rate of prevailing wage for any craft, classification or type of workmanship to be employed on this Project is the rate established by the applicable collective bargaining agreement which rate so provided is hereby adopted by reference and shall be effective for the life of this Agreement or until the Director of the Department of Industrial Relations determines that another rate be adopted. It shall be mandatory upon the Contractor and on any subcontractor to pay not less than the said specified rates to all workers employed in the execution of this Agreement.

This project is bound by the District’s Community Workforce Agreement (CWA) with the Los Angeles and Orange County Building and Construction Trade Councils, as referenced in the prospective bid documents.

The Contractor and any subcontractor under the Contractor as a penalty to the Owner shall forfeit not more than Two Hundred Dollars (\$200.00) for each calendar day or portion thereof for each worker paid less than the stipulated prevailing rates for such work or craft in which such

worker is employed. The difference between such stipulated prevailing wage rates and the amount paid to each worker for each calendar day or portion thereof for which each worker was paid less than the stipulated prevailing wage rate shall be paid to each worker by the Contractor.

The Contractor and each Subcontractor shall keep or cause to be kept an accurate record for Work on this Contract and Project showing the names, addresses, social security numbers, work classification, straight time and overtime hours worked and occupations of all laborers, workers and mechanics employed by them in connection with the performance of this Contract or any subcontract thereunder, and showing also the actual per diem wage paid to each of such workers, which records shall be open at all reasonable hours to inspection by the Owner, its officers and agents and to the representatives of the Division of Labor Standards Enforcement of the State Department of Industrial Relations. The Contractor and each subcontractor shall furnish a certified copy of all payroll records directly to the Labor Commissioner.

Public works projects shall be subject to compliance monitoring and enforcement by the Department of Industrial Relations. For all projects over Twenty-five Thousand Dollars (\$25,000), a contractor or subcontractor shall not be qualified to submit a bid or to be listed in a bid proposal subject to the requirements of Public Contract Code section 4104 unless currently registered and qualified under Labor Code section 1725.5 to perform public work as defined by Division 2, Part 7, Chapter 1 (§§ 1720 et seq.) of the Labor Code. For all projects over Twenty-five Thousand Dollars (\$25,000), a contractor or subcontractor shall not be qualified to enter into, or engage in the performance of, any contract of public work (as defined by Division 2, Part 7, Chapter 1 (§§ 1720 et seq.) of the Labor Code) unless currently registered and qualified under Labor Code section 1725.5 to perform public work.

**ARTICLE VIII. WORKING HOURS.** In accordance with the provisions of Sections 1810 to 1815, inclusive, of the Labor Code of the State of California, which are hereby incorporated and made a part hereof, the time of service of any worker employed by the Contractor or a Subcontractor doing or contracting to do any part of the Work contemplated by this Agreement is limited and restricted to eight hours during any one calendar day and forty hours during any one calendar week, provided, that work may be performed by such employee in excess of said eight hours per day or forty hours per week provided that compensation for all hours worked in excess of eight hours per day, and forty hours per week, is paid at a rate not less than one and one-half (1½) times the basic rate of pay. The Contractor and every Subcontractor shall keep an accurate record showing the name of and the actual hours worked each calendar day and each calendar week by each worker employed by them in connection with the Work. The records shall be kept open at all reasonable hours to inspection by representatives of the Owner and the Division of Labor Standards Enforcement. The Contractor shall as a penalty to the Owner forfeit Twenty-five Dollars (\$25.00) for each worker employed in the execution of this Agreement by the Contractor or by any subcontractor for each calendar day during which such worker is required or permitted to work more than eight hours in any one calendar day, and forty hours in any one calendar week, except as herein provided.

**ARTICLE IX. APPRENTICES.** The Contractor agrees to comply with Chapter 1, Part 7, Division 2, Sections 1777.5 and 1777.6 of the California Labor Code, which are hereby incorporated and made a part hereof. These sections require that contractors and subcontractors

employ apprentices in apprenticeable occupations in a ratio of not less than one hour of apprentice's work for each five hours of work performed by a journeyman (unless an exemption is granted in accordance with Section 1777.5) and that contractors and subcontractors shall not discriminate among otherwise qualified employees as indentured apprentices on any public works solely on the ground of sex, race, religious creed, national origin, ancestry or color. Only apprentices as defined in Labor Code Section 3077, who are in training under apprenticeship standards and who have signed written apprentice agreements, will be employed on public works in apprenticeable occupations. The responsibility for compliance with these provisions is fixed with the Contractor for all apprenticeable occupations.

**ARTICLE X. DSA OVERSIGHT PROCESS.** The Contractor must comply with the applicable requirements of the Division of State Architect (“DSA”) Construction Oversight Process (“DSA Oversight Process”), including but not limited to (a) notifying the Owner’s Inspector of Record/Project Inspector (“IOR”) upon commencement and completion of each aspect of the Work as required under DSA Form 156; (b) coordinating the Work with the IOR’s inspection duties and requirements; (c) submitting verified reports under DSA Form 6-C; and (d) coordinating with the Owner, Owner’s Architect, any Construction Manager, any laboratories, and the IOR to meet the DSA Oversight Process requirements without delay or added costs to the Work or Project.

Contractor shall be responsible for any additional DSA fees related to review of proposed changes to the DSA-approved construction documents, to the extent the proposed changes were caused by Contractor’s wrongful act or omissions. If inspected Work is found to be in non-compliance with the DSA-approved construction documents or the DSA-approved testing and inspection program, then it must be removed and corrected. Any construction that covers unapproved or uninspected Work is subject to removal and correction, at Contractor’s expense, in order to permit inspection and approval of the covered work in accordance with the DSA Oversight Process.

**ARTICLE XI. INDEMNIFICATION AND INSURANCE.** The Contractor will defend, indemnify and hold harmless the Owner, its governing board, officers, agents, trustees, employees and others as provided in the General Conditions.

By this statement the Contractor represents that it has secured the payment of Workers' Compensation in compliance with the provisions of the Labor Code of the State of California and during the performance of the work contemplated herein will continue so to comply with said provisions of said Code. The Contractor shall supply the Owner with certificates of insurance evidencing that Workers' Compensation Insurance is in effect and providing that the Owner will receive thirty (30) days' notice of cancellation.

Contractor shall provide the insurance set forth in the General Conditions. The amount of general liability insurance shall be \$1,000,000.00 per occurrence for bodily injury, personal injury and property damage and the amount of automobile liability insurance shall be \$1,000,000.00 per accident for bodily injury and property damage combined single limit.

**ARTICLE XII. ENTIRE AGREEMENT.** The Contract constitutes the entire agreement between the parties relating to the Work and supersedes any prior or contemporaneous agreement between the parties, oral or written, including the Owner's award of the Contract to Contractor, unless such agreement is expressly incorporated herein. The Owner makes no representations or warranties, express or implied, not specified in the Contract. The Contract is intended as the complete and exclusive statement of the parties' agreement pursuant to Code of Civil Procedure section 1856.

**ARTICLE XIII. EXECUTION OF OTHER DOCUMENTS.** The parties to this Agreement shall cooperate fully in the execution of any and all other documents and in the completion of any additional actions that may be necessary or appropriate to give full force and effect to the terms and intent of the Contract.

**ARTICLE XIV. EXECUTION IN COUNTERPARTS.** This Agreement may be executed in counterparts such that the signatures may appear on separate signature pages. A copy, or an original, with all signatures appended together, shall be deemed a fully executed Agreement.

**ARTICLE XV. BINDING EFFECT.** Contractor, by execution of this Agreement, acknowledges that Contractor has read this Agreement and the other Contract Documents, understands them, and agrees to be bound by their terms and conditions. The Contract shall inure to the benefit of and shall be binding upon the Contractor and the Owner and their respective successors and assigns.

**ARTICLE XVI. SEVERABILITY; GOVERNING LAW; CHOICE OF FORUM.** If any provision of the Contract shall be held invalid or unenforceable by a court of competent jurisdiction, such holding shall not invalidate or render unenforceable any other provision hereof. The Contract shall be governed by the laws of the State of California. Any action or proceeding seeking any relief under or with respect to this Agreement shall be brought solely in the Superior Court of the State of California for the County of Los Angeles, subject to transfer of venue under applicable State law, provided that nothing in this Agreement shall constitute a waiver of immunity to suit by Owner.

**ARTICLE XVII. AMENDMENTS.** The terms of the Contract shall not be waived, altered, modified, supplemented or amended in any manner whatsoever except by written agreement, including change orders, signed by the parties and approved or ratified by the Governing Board.

**ARTICLE XVIII. ASSIGNMENT OF CONTRACT.** The Contractor shall not assign or transfer by operation of law or otherwise any or all of its rights, burdens, duties or obligations without the prior written consent of the surety on the payment bond, the surety on the performance bond and the Owner.

**ARTICLE XIX. WRITTEN NOTICE.** Written notice shall be deemed to have been duly served if delivered in person to the individual or member of the firm or to an officer of the corporation for whom it was intended, or if delivered at or sent by registered or certified or overnight mail to the last business address known to the person who gives the notice.

\_\_\_\_\_ (*CONTRACTOR*)

Antelope Valley Union High School District

\_\_\_\_\_  
\_\_\_\_\_  
\_\_\_\_\_ (*Name*)  
\_\_\_\_\_ (Chairman, Pres., or Vice-Pres.)

\_\_\_\_\_  
Deputy Superintendent or Designee

\_\_\_\_\_  
\_\_\_\_\_  
\_\_\_\_\_ (*Name*)  
\_\_\_\_\_ (Secretary, Asst. Secretary, CFO, or Asst. Treasurer)

\_\_\_\_\_  
CALIFORNIA CONTRACTOR'S  
LICENSE NO.

\_\_\_\_\_  
LICENSE EXPIRATION DATE

**NOTE:** Contractor must give the full business address of the Contractor and sign with Contractor's usual signature. Partnerships must furnish the full name of all partners and the Agreement must be signed in the partnership name by a general partner with authority to bind the partnership in such matters, followed by the signature and designation of the person signing. The name of the person signing shall also be typed or printed below the signature. Corporations must sign with the legal name of the corporation, followed by the name of the state of incorporation and by the signature and designation of the chairman of the board, president or any vice president, and then followed by a second signature by the secretary, assistant secretary, the chief financial officer or assistant treasurer. All persons signing must be authorized to bind the corporation in the matter. The name of each person signing shall also be typed or printed below the signature. Satisfactory evidence of the authority of the officer signing on behalf of a corporation shall be furnished.



**BID FORM**

ANTELOPE VALLEY UNION HIGH SCHOOL DISTRICT

176 HOLSTON AVE, LANCASTER CA, 93535

Dear Board Members:

The undersigned doing business under the firm name of:

\_\_\_\_\_ hereby propose and agree to enter into a Contract, to furnish any and all labor, materials, applicable taxes, equipment and services for the Completion of Work described hereinafter and in the Contract Documents:

**Bid# 15/23-24-Desert Winds, Eastside, and R. Rex Parris High Schools Re-Roofs**

prepared by: Scott Fish

<b><u>Desert Winds High School</u></b>	Dollars (\$ _____ )
<b><u>Eastside High School</u></b>	Dollars (\$ _____ )
<b><u>R. Rex Parris High School</u></b>	Dollars (\$ _____ )
 <b><u>Total Project Bid</u></b>	 Dollars (\$ _____ )

**Miscellaneous:**

The low bid shall be determined as described in the Notice to Bidders.

If written notice of the Award of Contract is mailed, faxed, or delivered to the undersigned at any time before this bid is withdrawn, the undersigned shall, within ten (10) days after the date of such mailing, faxing, or delivering of such notice, execute and deliver an agreement in the form of agreement present in these Contract Documents and give Performance and Payment Bonds in accordance with the specifications and bid as accepted.

The undersigned hereby designates as the office to which such Notice of Award of Contract may be mailed, faxed, or delivered:

\_\_\_\_\_

\_\_\_\_\_

Our Public Liability and Property Damage Insurance is placed with:

\_\_\_\_\_

\_\_\_\_\_

Our Workers' Compensation Insurance is placed with:

---

---

Circular letters, bulletins, addenda, etc., bound with the specifications or issued during the time of bidding are included in the bid, and, in Completing the Contract, they are to become a part thereof.

The receipt of the following addenda to the specifications is acknowledged:

Addendum No. \_\_\_\_\_ Date \_\_\_\_\_ Addendum No. \_\_\_\_\_ Date \_\_\_\_\_

Addendum No. \_\_\_\_\_ Date \_\_\_\_\_ Addendum No. \_\_\_\_\_ Date \_\_\_\_\_

Addendum No. \_\_\_\_\_ Date \_\_\_\_\_ Addendum No. \_\_\_\_\_ Date \_\_\_\_\_

This bid may be withdrawn at any time prior to the scheduled time for the opening of bids or any authorized postponement thereof.

A bidder shall not submit a bid unless the bidder's California contractor's license number appears clearly on the bid, the license expiration date and class are stated, and the bid contains a statement that the representations made therein are made under penalty of perjury. Any bid submitted by a contractor who is not licensed pursuant to Business and Professions Code section 7028.15 shall be considered nonresponsive and shall be rejected. Any bid not containing the above information may be considered nonresponsive and may be rejected.

Proof of Bidder's registration per Labor Code §1725.5 must be submitted with this bid form.

**NOTE:** Each bid must give the full business address of the bidder and be signed by bidder with bidder's usual signature. Bids by partnerships must furnish the full name of all partners and must be signed in the partnership name by a general partner with authority to bind the partnership in such matters, followed by the signature and designation of the person signing. The name of the person signing shall also be typed or printed below the signature. Bids by corporations must be signed with the legal name of the corporation, followed by the name of the state of incorporation and by the signature and designation of the chairman of the board, president or any vice president, and then followed by a second signature by the secretary, assistant secretary, the chief financial officer or assistant treasurer. All persons signing must be authorized to bind the corporation in the matter. The name of each person signing shall also be typed or printed below the signature. Satisfactory evidence of the authority of the officers signing on behalf of a corporation shall be furnished with the bid.

The undersigned declares under penalty of perjury under the laws of the State of California that the representations made in this bid are true and correct.

Print or Type Name: \_\_\_\_\_

Title: \_\_\_\_\_

Name of Company as Licensed in California: \_\_\_\_\_

Business Address: \_\_\_\_\_

Telephone Number: \_\_\_\_\_

California Contractor License No.: \_\_\_\_\_

Class and Expiration Date: \_\_\_\_\_

Public Works Contractor Registration No.: \_\_\_\_\_

State of Incorporation, if Applicable: \_\_\_\_\_

INDIVIDUAL:

Dated: \_\_\_\_\_, 20\_\_

\_\_\_\_\_  
\_\_\_\_\_  
\_\_\_\_\_  
(Name)

PARTNERSHIP:

Evidence of authority to bind partnership is attached.

Dated: \_\_\_\_\_, 20\_\_

\_\_\_\_\_  
\_\_\_\_\_  
\_\_\_\_\_  
(Name)

General Partner

CORPORATION:

Evidence of authority to bind corporation is attached.

Dated: \_\_\_\_\_, 20\_\_

\_\_\_\_\_  
\_\_\_\_\_  
\_\_\_\_\_  
(Name)  
(Chairman, Pres., or Vice-Pres.)

\_\_\_\_\_  
\_\_\_\_\_  
\_\_\_\_\_  
(Name)  
(Secretary, Asst. Secretary, CFO, or Asst. Treasurer)

## BID BOND

KNOW ALL MEN BY THESE PRESENTS that we the undersigned \_\_\_\_\_ as Principal and \_\_\_\_\_ as Surety, are hereby held and firmly bound unto the \_\_\_\_\_ "Owner" in the sum of \_\_\_\_\_ Dollars (\$ \_\_\_\_\_) for payment of which sum, well and truly to be made, we hereby jointly and severally bind ourselves, our heirs, executors, administrators, successors and assigns.

The condition of the above obligation is such that whereas the Principal has submitted to the Owner a certain bid, attached hereto and hereby made a part hereof, to enter into a Contract in writing for the construction of \_\_\_\_\_ in strict accordance with Contract Documents.

NOW, THEREFORE,

- a. If said bid shall be rejected, or, in the alternative;
- b. If said bid shall be accepted and the Principal shall execute and deliver a contract in the form of agreement attached hereto and shall execute and deliver Performance and Payment Bonds in the forms attached hereto (all properly completed in accordance with said bid), and shall in all other respects perform the agreement created by the acceptance of said bid;

Then this obligation shall be void, otherwise the same shall remain in full force and effect, it being expressly understood and agreed that the liability of the Surety for any and all default of the Principal hereunder shall be the amount of this obligation as herein stated.

Surety, for value received, hereby stipulates and agrees that no change, extension of time, alteration or addition to the terms of the Contract on the call for bids, or to the Work to be performed hereunder, or the specifications accompanying the same, shall in any way affect its obligation under this bond, and it does hereby waive notice of any such change, extension of time, alteration or addition to the terms of said Contract or the call for bids, or to the Work, or to the specifications.

IN WITNESS WHEREOF, the above-bounden parties have executed this instrument under several seals this \_\_\_\_ day of \_\_\_\_\_, \_\_\_\_\_, the name and corporate party being hereto affixed and these presents duly signed by its

undersigned representative, pursuant to authority of its governing body. In the presence of:

(Notary Seal)

\_\_\_\_\_  
(Principal)

\_\_\_\_\_  
(Business Address)

\_\_\_\_\_  
(Corporate Surety)

\_\_\_\_\_  
Business Address)

By: \_\_\_\_\_

\_\_\_\_\_

The rate or premium of this bond is \_\_\_\_\_ per thousand, the total amount of premium charged, \$ \_\_\_\_\_.

(The above must be filled in by Corporate Surety).

**PAYMENT BOND**  
**(Labor and Material)**

**KNOW ALL MEN BY THESE PRESENTS:**

That WHEREAS, the AVUHSD (the "Owner" of the public works project described below) and \_\_\_\_\_, hereinafter designated as the "Principal," have entered into a Contract for the furnishing of all materials and labor, services and transportation, necessary, convenient, and proper to construct:

**Bid# 15/23-24 Desert Winds, Eastside, and R. Rex Parris High Schools Re-Roofs**

Which said agreement dated \_\_\_\_\_, and all of the Contract Documents are hereby referred to and made a part hereof;

and

WHEREAS, the Principal is required, before entering upon the performance of the work, to file a good and sufficient bond with the body by whom the Contract is awarded to secure the claims arising under said agreement.

**NOW, THEREFORE, THESE PRESENTS WITNESSETH:**

That the said Principal and the undersigned \_\_\_\_\_ ("Surety") are held and firmly bound unto all laborers, material men, and other persons, and bound for all amounts due, referred to in Civil Code section 9554, subdivision (b), in the sum of \_\_\_\_\_ **Dollars (\$\_\_\_\_\_)** which sum well and truly be made, we bind ourselves, our heirs, executors, administrators, successors, or assigns, jointly and severally, by these presents.

The condition of this obligation is that if the said Principal or any of its subcontractors, or the heirs, executors, administrators, successors, or assigns of any, all, or either of them, shall fail to pay any of the persons named in Civil Code section 9100, or any of the amounts due, as specified in Civil Code section 9554, subdivision (b), that said Surety will pay the same in an amount not exceeding the amount hereinabove set forth, and also in case suit is brought upon this bond, will pay costs and reasonable attorney's fees to be awarded and fixed by the Court, and to be taxed as costs and to be included in the judgment therein rendered.

It is hereby expressly stipulated and agreed that this bond shall inure to the benefit of any and all persons, companies, and corporations entitled to file claims so as to give a right of action to them or their assigns in any suit brought upon this bond.

Should the condition of this bond be fully performed, then this obligation shall become null and void, otherwise it shall be and remain in full force and effect.

And the said Surety, for value received, thereby stipulates and agrees that no change, extension of time, alteration, or addition to the terms of said contract or the specifications accompanying the same shall in any manner affect its obligations on this bond, and it does hereby waive notice of any such change, extension, alteration, or addition.

IN WITNESS WHEREOF, this instrument has been duly executed by the Principal and Surety this \_\_\_\_\_ day of \_\_\_\_\_, \_\_\_\_\_.

(To be signed by \_\_\_\_\_ )  
(Principal and Surety, \_\_\_\_\_ )  
(and acknowledged and \_\_\_\_\_ )  
(Notarial Seal attached \_\_\_\_\_ )

\_\_\_\_\_  
Principal

\_\_\_\_\_  
Surety

By: \_\_\_\_\_  
Attorney-in-Fact

The above bond is accepted and approved this \_\_\_\_ day of \_\_\_\_\_.

## PERFORMANCE BOND

**KNOW ALL MEN BY THESE PRESENTS** that we, \_\_\_\_\_  
\_\_\_\_\_ as Principal and  
\_\_\_\_\_ as Surety, are held and  
firmly bound unto \_\_\_\_\_, in the County of \_\_\_\_\_, State of California, hereinafter  
called the "Owner", in the sum of \_\_\_\_\_ Dollars  
(\$ \_\_\_\_\_) for the payment of which sum well and truly made, we bind  
ourselves, our heirs, executors, administrators, and successors, jointly and severally, to  
the Owner for the full performance of a certain contract with the Owner, the terms of  
which are incorporated herein by reference, dated \_\_\_\_\_, 20\_\_\_\_, for  
construction of:

### **Bid# 15/23-24 Desert Winds, Eastside, and R. Rex Parris High Schools Re-Roofs**

The condition of this obligation is such that, if the Principal shall well and truly perform and fulfill all the undertakings, covenants, terms, conditions, and agreements of said Contract during the original term of said Contract and any extensions thereof that may be granted by the Owner, with or without notice to the Surety, and for the period of time specified in the Contract after completion for correction of faulty or improper materials and workmanship and during the life of any guaranty or warranty required under the Contract, and shall also well and truly perform and fulfill all the undertakings, covenants, terms, conditions and agreement of any and all duly authorized modifications of said Contract that may hereafter be made, then this obligation is to be void, otherwise to remain in full force and virtue.

And the said Surety, for value received, hereby stipulates and agrees that no change, extension of time, alteration or addition to the terms of the Contract or to the Work to be performed thereunder or the specifications accompanying the same, shall in any way affect its obligation on this bond, and it does hereby waive notice of any such change, extension of time, alteration or addition to the terms of the Contract, or to the Work, or to the specifications.

No further agreement between Surety and Owner shall be required as a prerequisite to the Surety performing its obligations under this bond.



**IN WITNESS WHEREOF**, the above-bounden parties have executed this instrument under their several seals this \_\_\_\_\_ day of \_\_\_\_\_, \_\_\_\_\_ hereto affixed and these presents duly signed by its undersigned representative, pursuant to authority of its governing body.

(To be signed by \_\_\_\_\_ )  
(Principal and Surety, \_\_\_\_\_ )  
(and acknowledged and \_\_\_\_\_ )  
(Notarial Seal attached \_\_\_\_\_ )

(Affix Corporate Seal)

\_\_\_\_\_  
(Individual Principal)

\_\_\_\_\_  
(Business Address)

(Affix Corporate Seal)

\_\_\_\_\_  
(Corporate Principal)

\_\_\_\_\_  
(Business Address)

(Affix Corporate Seal)

\_\_\_\_\_  
(Corporate Surety)

\_\_\_\_\_  
(Business Address)

\_\_\_\_\_

By: \_\_\_\_\_

\_\_\_\_\_

The rate of premium on this bond is \_\_\_\_\_ per thousand.

The total amount of premium charged is \_\_\_\_\_.

The above must be filled in by Corporate Surety.

## DESIGNATION OF SUBCONTRACTORS

Each bidder shall set forth below the name and the location of the place of business of each subcontractor and the California contractor license number, and public works contractor registration number (for all projects over Twenty-five Thousand Dollars (\$25,000)), of each subcontractor who will perform work or labor or render service to the Contractor in or about the construction of the Work or improvement, or to a subcontractor licensed by the State of California who, under subcontract to the Contractor, specially fabricates and installs a portion of the Work or improvement according to detailed drawings contained in the plans and specifications, in an amount in excess of one-half of 1 percent (0.5%) of the bidder's total bid, and the portion of the Work which will be done by each subcontractor. An inadvertent error in listing a California contractor's license number shall not be grounds for filing a bid protest or for considering the bid nonresponsive if the bidder submits the corrected contractor's license number to the Owner within 24 hours after the bid opening, or any continuation thereof, so long as the corrected contractor's license number corresponds to the submitted name and location for that subcontractor. If the Contractor fails to specify a subcontractor for any portion of the Work to be performed under the Contract in excess of one-half of 1 percent (0.5%) of the Contractor's total bid, the Contractor shall be deemed to have agreed to perform such portion itself, and shall not be permitted to subcontract that portion of the Work except under the conditions hereinafter set forth.

Subletting or subcontracting of any portion of the Work as to which no subcontractor was designated in the original bid shall only be permitted in cases of public emergency or necessity, and then only after a finding reduced to writing as a public record of the legislative body of the Owner.

For all projects over Twenty-five Thousand Dollars (\$25,000): for any bid proposal submitted and for any contract for public work entered into, an inadvertent error in listing a subcontractor who is not registered under Labor Code section 1725.5 shall not be grounds for filing a bid protest or grounds for considering the bid nonresponsive, provided that either: the subcontractor is registered prior to the bid opening; or the subcontractor is registered and has paid the penalty registration fee specified in Labor Code section 1725.5(a)(2)(E), if applicable, within 24 hours after the bid opening; or the subcontractor is replaced by another registered subcontractor under Public Contract Code section 4107. Failure of a listed subcontractor to be registered shall be grounds under Public Contract Code section 4107 for the Contractor, with the Owner's consent, to substitute a registered subcontractor for the unregistered subcontractor.

Failure to provide this information in a legible manner may result in the rejection of an otherwise acceptable bid.

**NOTE:** *Reproduce page two of this section for additional listings needed beyond the length of this form.*



I am the authorized representative of the Bidder submitting this Designation of Subcontractors and I declare that each subcontractor listed holds a valid and current contractor license in good standing in California to perform the portion of work for which the subcontractor is listed.

I declare under penalty of perjury under the laws of the State of California that the foregoing is true and correct and that this declaration is executed on \_\_\_\_\_, 20\_\_\_\_, at \_\_\_\_\_[city], \_\_\_\_\_[state].

Signature: \_\_\_\_\_

Print Name: \_\_\_\_\_

Title: \_\_\_\_\_

## DRUG-FREE WORKPLACE CERTIFICATION

This Drug-Free Workplace Certification is required pursuant to Government Code Sections 8350 *et seq.*, the Drug-Free Workplace Act of 1990. The Drug-Free Workplace Act of 1990 requires that every person or organization awarded a contract or grant for the procurement of any property or services from any State agency must certify that it will provide a drug-free workplace by doing certain specified acts. In addition, the Act provides that each contract awarded by a State agency may be subject to suspension of payments or termination of the contract, or both, and the contractor may be subject to debarment from future contracting if the state agency determines that specified acts have occurred.

Pursuant to Government Code Section 8355, every person or organization awarded a contract or grant from a State agency shall certify that it will provide a drug-free workplace by doing all of the following:

- (a) Publishing a statement notifying employees that the unlawful manufacture, distribution, dispensation, possession or use of a controlled substance is prohibited in the person's or organization's workplace and specifying actions which will be taken against employees for violations of the prohibition;
- (b) Establishing a drug-free awareness program to inform employees about all of the following:
  - (1) The dangers of drug abuse in the workplace;
  - (2) The person's or organization's policy of maintaining a drug-free workplace;
  - (3) The availability of drug counseling, rehabilitation and employee-assistance programs;
  - (4) The penalties that may be imposed upon employees for drug abuse Violations;
- (c) Requiring that each employee engaged in the performance of the contract or grant be given a copy of the statement required by subdivision (a) and that, as a condition of employment on the contract or grant, the employee agrees to abide by the terms of the statement.

I, the undersigned, agree to fulfill the terms and requirements of Government Code Section 8355 listed above and will publish a statement notifying employees concerning (a) the prohibition of controlled substance at the workplace, (b) establishing a drug-free awareness program, and (c) requiring that each employee engaged in the performance of the contract or grant be given a copy of the statement required by Section 8355(a) and requiring that the employee agree to abide by the terms of that statement.

I also understand that if the Owner determines that I have either (a) made a false certification herein, or (b) violated this certification by failing to carry out the requirements of Section 8355, that the contract or grant awarded herein is subject to suspension of payments, termination, or both. I further understand that should I violate the terms of the Drug-Free Workplace Act of 1990, I may be subject to debarment in accordance with the requirements of Section 8350 *et seq.*

I acknowledge that I am aware of the provisions of Government Code Section 8350 *et seq.* and hereby certify that I will adhere to the requirements of the Drug-Free Workplace Act of 1990.

\_\_\_\_\_  
Name of Contractor

\_\_\_\_\_  
Signature

\_\_\_\_\_  
Print Name

\_\_\_\_\_  
Date

**This is a fiduciary account created by statute, Public Contract Code section 22300. The funds deposited in this account shall not be released to Contractor or any other person or entity, other than Owner, including pursuant to any purported lien or writ of attachment or execution, without the prior written, express approval of Owner.**

## **ESCROW AGREEMENT FOR SECURITY DEPOSITS IN LIEU OF RETENTION**

This Escrow Agreement is made and entered into by and between the \_\_\_\_\_, whose address is \_\_\_\_\_ (hereinafter called "Owner"), \_\_\_\_\_ whose address is \_\_\_\_\_ (hereinafter called "Contractor"); and \_\_\_\_\_, a state or federally chartered bank in California whose address is \_\_\_\_\_ (hereinafter called "Escrow Agent").

For the consideration hereinafter set forth, the Owner, Contractor, and Escrow Agent agree as follows:

1. Pursuant to section 22300 of the Public Contract Code of the State of California, Contractor has the option to deposit securities with Escrow Agent as a substitute for retention earnings required to be withheld by the Owner pursuant to the Contract entered into between the Owner and Contractor in the amount of \_\_\_\_\_ Dollars (\$ \_\_\_\_\_), and dated \_\_\_\_\_, \_\_\_\_\_, (the "Contract"). Alternatively, on written request of the Contractor, the Owner shall make payments of the retention earnings directly to the Escrow Agent. When Contractor deposits the securities as a substitute for retention earnings, the Escrow Agent shall notify the Owner within ten (10) calendar days of the deposit. The market value of the securities at the time of the substitution, as valued by the Owner, shall be at least equal to the cash amount then required to be withheld as retention under the terms of the Contract between the Owner and Contractor. If the Owner determines that the securities are not adequate it will notify Contractor and Escrow Agent, and Contractor shall deposit additional security as further determined by the Owner. Securities shall be held in the name of the Owner and shall designate the Contractor as the beneficial owner.
2. Thereafter, Owner shall make progress payments to the Contractor for such funds which otherwise would be withheld from progress payments pursuant to the Contract provisions, provided that the Escrow Agent holds securities in the form and amount specified above.
3. Pursuant to Public Contract Code section 22300, as an alternative to the procedures set forth above, Contractor may request in writing that the Owner pay retention amounts directly to Escrow Agent. When the Owner makes payment of

retentions earned directly to the Escrow Agent, the Escrow Agent shall hold them for benefit of the Contractor until such time as the escrow created under this Escrow Agreement is terminated. The Contractor may direct the investment of the payments into securities. All terms and conditions of this Escrow Agreement and the rights and responsibilities of the parties shall be equally applicable and binding when the Owner pays the Escrow Agent directly.

4. The Contractor shall be responsible for paying all fees for the expenses incurred by Escrow Agent in administering the Escrow Account and all expenses of the Owner. These expenses and payment terms shall be determined by the Owner, Contractor and Escrow Agent.
5. The interest earned on the securities or the money market accounts held in escrow and all interest earned on that interest shall be for the sole account of Contractor and shall be subject to withdrawal by Contractor at any time and from time to time without notice to the Owner.
6. Contractor shall have the right to withdraw all or any part of the principal in the Escrow Account only by written notice to Escrow Agent accompanied by written authorization from Owner to the Escrow Agent that Owner consents to the withdrawal of the amount sought to be withdrawn by Contractor.
7. The Owner shall have the right to draw upon the securities or any amount paid directly to Escrow Agent in the event of default by the Contractor. Upon seven (7) days written notice to the Escrow Agent from the Owner of the default, the Escrow Agent shall immediately convert the securities to cash and shall distribute the cash, including any amounts paid directly to Escrow Agent pursuant to Section 3 above, as instructed by Owner. Escrow Agent shall not be concerned with the validity of any notice of default given by Owner pursuant to this paragraph, and shall promptly comply with Owner's instructions to pay over said escrowed assets. Escrow Agent further agrees to not interplead the escrowed assets in response to a conflicting demand and hereby waives any present or future opportunity of interpleader.
8. Upon receipt of written notification from the Owner certifying that the Contract is final and complete, and that the Contractor has complied with all requirements and procedures applicable to the Contract, Escrow Agent shall release to Contractor all securities and interest on deposit less escrow fees and charges of the Escrow Account. The escrow shall be closed immediately upon disbursement of all moneys and securities on deposit and payment of fees and charges.
9. Escrow Agent shall rely on the written notifications from the Owner and Contractor pursuant to Sections (4), (5), (6), (7) and (8) of this Agreement and the Owner and Contractor shall hold Escrow Agent harmless from Escrow Agent's release and disbursement of the securities and interest as set forth above.

10. The names of the persons who are authorized to give written notice or to receive written notice on behalf of the Owner, the Contractor and the Escrow Agent in connection with the foregoing, and exemplars of their respective signatures are as follows:

ON BEHALF OF OWNER:

\_\_\_\_\_  
Signature

\_\_\_\_\_  
Typewritten Name

\_\_\_\_\_  
Title

ON BEHALF OF CONTRACTOR:

\_\_\_\_\_  
Signature

\_\_\_\_\_  
Typewritten Name

\_\_\_\_\_  
Title

ON BEHALF OF ESCROW AGENT:

\_\_\_\_\_  
Signature

\_\_\_\_\_  
Typewritten Name

\_\_\_\_\_  
Title

**IN WITNESS WHEREOF**, the parties have executed this Agreement by their proper officers on the date first set forth above.

OWNER:

\_\_\_\_\_  
Signature

\_\_\_\_\_  
Typewritten Name

\_\_\_\_\_  
Title



CONTRACTOR:

\_\_\_\_\_  
Signature

\_\_\_\_\_  
Typewritten Name

\_\_\_\_\_  
Title

ESCROW AGENT:

\_\_\_\_\_  
Signature

\_\_\_\_\_  
Typewritten Name

\_\_\_\_\_  
Title

At the time the Escrow Account is opened, the Owner and Contractor shall deliver to the Escrow Agent a fully executed counterpart of this Agreement.

**CONTRACTOR'S CERTIFICATE REGARDING  
ALCOHOLIC BEVERAGE AND TOBACCO-FREE CAMPUS POLICY**

The Contractor agrees that it will abide by and implement the District's Alcoholic Beverage and Tobacco-Free Campus Policy, which prohibits the use of alcoholic beverages and tobacco products, at any time, in District-owned or leased buildings, on District property and in District vehicles. The Contractor shall procure signs stating "ALCOHOLIC BEVERAGE AND TOBACCO USE IS PROHIBITED" and shall ensure that these signs are prominently displayed at all entrances to school property at all times.

\_\_\_\_\_  
Date

\_\_\_\_\_  
Company Name

\_\_\_\_\_  
Contact Name

\_\_\_\_\_  
Title

\_\_\_\_\_  
Authorized Signature

## DEMAND FOR PAYROLL RECORDS

### To be executed by Contractor and submitted with bid

Pursuant to Section 1776 of the Labor Code, Contractor agrees that its payroll records will be furnished to the District, or sent directly to the requesting public, no later than (10) days after written request.

The payroll records shall show the name, address, social security number, work classification, straight time and overtime hours worked each day and week, and the actual per diem wages paid to each journeyman, apprentice, worker, or other employee employed by the contractor in connection with the project. Each payroll record shall contain or be verified by a written declaration that it is made under penalty of perjury, stating both of the following: (1) the information contained in the payroll record is true and correct; (2) the employer has complied with the requirements of Labor Code §1771, 1811 and 1815 for any work performed by his or her employees on the project.

The certified payroll records shall be on forms provided by the Division of Labor Standards Enforcement or shall contain the same information as the forms provided by the division. The payroll records may consist of printouts of payroll data that are maintained as computer records, if the printouts contain the same information as the forms provided by the division and the printouts are verified in the manner specified above. The payroll records shall be uploaded to the DIR website through the eCPR application process.

No further request need be made by the District for the payroll records described herein.

**In the event that the contractor fails to comply within the 10-day period, he or she shall, as a penalty to the District, forfeit twenty-five dollars (\$25) for each calendar day, or portion thereof, for each worker, until strict compliance is effectuated. Upon the request of the Division of Apprenticeship Standards or the Division of Labor Standards Enforcement, these penalties shall be withheld from progress payments then due. A contractor is not subject to a penalty assessment pursuant to this section due to the failure of a subcontractor to comply with this section.**

By signing below, the Contractor agrees to furnish the records and to comply with the time schedule described herein, without further written request by the District.

\_\_\_\_\_  
Date

\_\_\_\_\_  
Company Name

\_\_\_\_\_  
Contact Name

\_\_\_\_\_  
Title

\_\_\_\_\_  
Authorized Signature

**ANTELOPE VALLEY JOINT UNION HIGH SCHOOL DISTRICT**

**NOTICE OF EXISTENCE OF ASBESTOS**

**To be executed by bidder and submitted with bid**

The Antelope Valley Joint Union High School District has determined that some of its buildings contain asbestos. Contractors shall make themselves aware of the exact locations of the asbestos before beginning any work by reviewing the AHERA Management Plan at each facility location. Contractors shall make all employees under their supervision aware of the asbestos and shall provide proper personal protection. Further information can be obtained by contacting the Facilities Department at (661) 942-8496 or (661) 948-7655, during normal business hours.

CONTRACTOR AGREES to abide by all applicable rules, regulations and laws governing potentially hazardous materials and/or properties therefrom.

CONTRACTOR AGREES to hold the Antelope Valley Joint Union High School District, its officers, agents, and employees, harmless from any and all liability or claims of Contractor, his or her agents, employees or assigns, which arise out of or in connection with Contractor's performance of the Contract.

\_\_\_\_\_  
Date

\_\_\_\_\_  
Company Name

\_\_\_\_\_  
Contact Name

\_\_\_\_\_  
Title

\_\_\_\_\_  
Authorized Signature

**VERIFICATION OF CONTRACTOR AND  
SUBCONTRACTORS' DIR REGISTRATION**

I am the \_\_\_\_\_ of \_\_\_\_\_ (“Bidder”)  
(Title/Position) (Bidder Name)

submitting the accompanying Bid Proposal for the Work described as **Bid# 15/23-24 Desert Winds, Eastside, and R. Rex Parris High Schools Re-Roofs**

1. The Bidder is currently registered as a contractor with the Department of Industrial Relations (“DIR”).
2. The Bidder’s DIR Registration Number is: \_ \_ . The expiration date of the Bidder’s DIR Registration is \_\_\_\_\_, 20 \_ .
3. If the Bidder is awarded the Contract for the Work and the expiration date of the Bidder’s DIR Registration will occur: (i) prior to expiration of the Contract Time for the Work; or (ii) prior to the Bidder completing all obligations under the Contract for the Work, the Bidder will take all measures necessary to renew the Bidder’s DIR Registration so that there is no lapse in the Bidder’s DIR Registration while performing Work under the Contract.
4. The Bidder, if awarded the Contract for the Work will remain a DIR registered contractor for the entire duration of the Work.
5. The Bidder has independently verified that each Subcontractor identified in the Subcontractors List submitted with the Bid Proposal of the Bidder is currently a DIR registered contractor.
6. The Bidder has provided the DIR Registration Number for each subcontractor identified in the Bidder’s Subcontractors’ List or within twenty-four (24) hours of the opening of Bid Proposals for the Work, the Bidder will provide the District with the DIR Registration Number for each subcontractor identified in the Bidder’s Subcontractors List.
7. The Bidder’s solicitation of subcontractor bids included notice to prospective subcontractors that: (i) all sub-tier subcontractors must be DIR registered contractors at all times during performance of the Work; and (ii) prospective subcontractors may only solicit sub-bids from and contract with lower-tier subcontractors who are DIR registered contractors.
8. If any of the statements herein are false or omit material facts rendering a statement to be false or misleading, the Bidder’s Bid Proposal is subject to rejection for non-responsiveness.
9. I have personal first hand-knowledge of all of the foregoing.

I declare under penalty of perjury under California law that the foregoing is true and correct.  
Executed this \_\_\_\_ day of \_\_\_\_\_, 20\_\_ at \_\_\_\_\_.  
(City and State)

\_\_\_\_\_  
(Signature)

\_\_\_\_\_  
(Name, typed or printed)

**FINGERPRINTING NOTICE AND ACKNOWLEDGMENT  
FOR CONSTRUCTION CONTRACTS**  
(Education Code Sections 45125.1 and 45125.2)

*Note: This document must be executed and submitted with the bid.*

Business entities entering into contracts with the Owner for the construction, reconstruction, rehabilitation or repair of a facility must comply with Education Code section 45125.2, and if such an entity is not compliant with Section 45125.2, then it must comply with Section 45125.1. Such entities are responsible for ensuring full compliance with the law and should therefore review all applicable statutes and regulations. The following information is provided to you, the bidding contractor, simply to assist you with compliance with the law.

1. If the Owner determines your employee(s) or you as a sole proprietorship will have more than limited contact with students, therefore the law requires that you must use one or more of the following methods to ensure the safety of pupils (Education Code §45125.2(a)):
  - a. Install a physical barrier at the worksite to limit contact with pupils.
  - b. If you are not a sole proprietorship, have one of your employees, whom the Department of Justice has ascertained has not been convicted of a violent or serious felony (see *Attachment A* to this Notice and Acknowledgement), continually monitor and supervise all of your employees. For the Department of Justice to so ascertain, your employee may submit fingerprints to the Department of Justice pursuant to Education Code section 45125.1(a).
  - c. Arrange, with Owner's approval, for surveillance of your employees by Owner's personnel.

Prior to commencing the Work, you shall submit the Independent Contractor Student Contact Form (see *Attachment B* to this Notice and Acknowledgement) to the Owner, which will indicate which of the above methods you will use.

2. If you are providing services in an emergency or exceptional situation, you are not required to comply with Education Code section 45125.2, above. An "emergency or exceptional" situation is one in which pupil health or safety is endangered or when repairs are needed to make a facility safe and habitable. Owner shall determine whether an emergency or exceptional situation exists. (Education Code §45125.2(d).)
3. If you use one or more of the three methods in Section 1 (above), you are not required to comply with Education Code section 45125.1. (Education Code §45125.2(b).)

I have read the foregoing and agree to comply with the requirements of this notice and Education Code sections 45125.1 and 45125.2 as applicable.

Dated: \_\_\_\_\_

\_\_\_\_\_  
Signature

Name: \_\_\_\_\_

Title: \_\_\_\_\_

## ATTACHMENT A

### Violent and Serious Felonies

Under Education Code section 45125.2, no employee of a contractor or subcontractor who has been convicted of or has criminal proceedings pending for a violent or serious felony may come into contact with any student. A violent felony is any felony listed in subdivision (c) of Section 667.5 of the Penal Code. Those felonies are presently defined as:

- (1) Murder or voluntary manslaughter.
- (2) Mayhem.
- (3) Rape as defined in paragraph (2) or (6) of subdivision (a) of Section 261 or paragraph (1) or (4) of subdivision (a) of Section 262.
- (4) Sodomy as defined in subdivision (c) or (d) of Section 286.
- (5) Oral copulation as defined in subdivision (c) or (d) of Section 288a.
- (6) Lewd or lascivious act as defined in subdivision (a) or (b) of Section 288.
- (7) Any felony punishable by death or imprisonment in the state prison for life.
- (8) Any felony in which the defendant inflicts great bodily injury on any person other than an accomplice which has been charged and proved as provided for in Section 12022.7, 12022.8, or 12022.9 on or after July 1, 1977, or as specified prior to July 1, 1977, in Sections 213, 264, and 461, or any felony in which the defendant uses a firearm which use has been charged and proved as provided in subdivision (a) of Section 12022.3, or Section 12022.5 or 12022.55.
- (9) Any robbery.
- (10) Arson, in violation of subdivision (a) or (b) of Section 451.
- (11) Sexual penetration as defined in subdivision (a) or (j) of Section 289.
- (12) Attempted murder.
- (13) A violation of Section 18745, 18750, or 18755.
- (14) Kidnapping.
- (15) Assault with the intent to commit a specified felony, in violation of Section 220.
- (16) Continuous sexual abuse of a child, in violation of Section 288.5.
- (17) Carjacking, as defined in subdivision (a) of Section 215.



- (18) Rape, spousal rape, or sexual penetration, in concert, in violation of Section 264.1.
- (19) Extortion, as defined in Section 518, which would constitute a felony violation of Section 186.22 of the Penal Code.
- (20) Threats to victims or witnesses, as defined in Section 136.1, which would constitute a felony violation of Section 186.22 of the Penal Code.
- (21) Any burglary of the first degree, as defined in subdivision (a) of Section 460, wherein it is charged and proved that another person, other than an accomplice, was present in the residence during the commission of the burglary.
- (22) Any violation of Section 12022.53.
- (23) A violation of subdivision (b) or (c) of Section 11418.

A serious felony is any felony listed in subdivision (c) Section 1192.7 of the Penal Code. Those felonies are presently defined as:

- (1) Murder or voluntary manslaughter; (2) Mayhem; (3) Rape; (4) Sodomy by force, violence, duress, menace, threat of great bodily injury, or fear of immediate and unlawful bodily injury on the victim or another person; (5) Oral copulation by force, violence, duress, menace, threat of great bodily injury, or fear of immediate and unlawful bodily injury on the victim or another person; (6) Lewd or lascivious act on a child under the age of 14 years; (7) Any felony punishable by death or imprisonment in the state prison for life; (8) Any felony in which the defendant personally inflicts great bodily injury on any person, other than an accomplice, or any felony in which the defendant personally uses a firearm; (9) Attempted murder; (10) Assault with intent to commit rape, or robbery; (11) Assault with a deadly weapon or instrument on a peace officer; (12) Assault by a life prisoner on a non-inmate; (13) Assault with a deadly weapon by an inmate; (14) Arson; (15) Exploding a destructive device or any explosive with intent to injure; (16) Exploding a destructive device or any explosive causing bodily injury, great bodily injury, or mayhem; (17) Exploding a destructive device or any explosive with intent to murder; (18) Any burglary of the first degree; (19) Robbery or bank robbery; (20) Kidnapping; (21) Holding of a hostage by a person confined in a state prison; (22) Attempt to commit a felony punishable by death or imprisonment in the state prison for life; (23) Any felony in which the defendant personally used a dangerous or deadly weapon; (24) Selling, furnishing, administering, giving, or offering to sell, furnish, administer, or give to a minor any heroin, cocaine, phencyclidine (PCP), or any methamphetamine-related drug, as described in paragraph (2) of subdivision (d) of Section 11055 of the Health and Safety Code, or any of the precursors of methamphetamines, as described in subparagraph (A) of paragraph (1) of subdivision (f) of Section 11055 or subdivision (a) of Section 11100 of the Health and Safety Code; (25) Any violation of

subdivision (a) of Section 289 where the act is accomplished against the victim's will by force, violence, duress, menace, or fear of immediate and unlawful bodily injury on the victim or another person; (26) Grand theft involving a firearm; (27) carjacking; (28) any felony offense, which would also constitute a felony violation of Section 186.22; (29) assault with the intent to commit mayhem, rape, sodomy, or oral copulation, in violation of Section 220; (30) throwing acid or flammable substances, in violation of Section 244; (31) assault with a deadly weapon, firearm, machine gun, assault weapon, or semiautomatic firearm or assault on a peace officer or firefighter, in violation of Section 245; (32) assault with a deadly weapon against a public transit employee, custodial officer, or school employee, in violation of Sections 245.2, 245.3, or 245.5; (33) discharge of a firearm at an inhabited dwelling, vehicle, or aircraft, in violation of Section 246; (34) commission of rape or sexual penetration in concert with another person, in violation of Section 264.1; (35) continuous sexual abuse of a child, in violation of Section 288.5; (36) shooting from a vehicle, in violation of subdivision (c) or (d) of Section 26100; (37) intimidation of victims or witnesses, in violation of Section 136.1; (38) criminal threats, in violation of Section 422; (39) any attempt to commit a crime listed in this subdivision other than an assault; (40) any violation of Section 12022.53; (41) a violation of subdivision (b) or (c) of Section 11418; and (42) any conspiracy to commit an offense described in this subdivision.

**ATTACHMENT B**

**INDEPENDENT CONTRACTOR STUDENT CONTACT FORM**

*Note: This document must be executed and submitted by Contractor before Contractor may commence any work.*

Contractor Firm Name: \_\_\_\_\_  
Supervisor/Foreman Name: \_\_\_\_\_  
Start Date: \_\_\_\_\_  
Completion Date: \_\_\_\_\_  
Location of Work: \_\_\_\_\_  
Hours of Work: \_\_\_\_\_  
Length of Time on Grounds: \_\_\_\_\_  
Number of Employees on the Job: \_\_\_\_\_

The Owner has determined that my employees, or that I as a sole proprietor, will have more than limited contact with students. Therefore, pursuant to Education Code section 45125.2, my firm will use the following methods to ensure student safety (check at least one):

- A physical barrier will be installed at the worksite to limit contact with pupils.
- I am not a sole proprietorship, and my employees will be continually monitored and supervised by one of my employees who has not been convicted of a violent or serious felony.

Name of Supervising Employee:  
\_\_\_\_\_

Date of Department of Justice verification that supervising employee has not been convicted of a violent or serious felony:  
\_\_\_\_\_

Name of employee who is the custodian of the Department of Justice verification information:  
\_\_\_\_\_

- The Owner has agreed that my employees or sole proprietor will be surveilled by Owner's personnel.

I declare under penalty of perjury that the foregoing is true and correct to the best of my knowledge.

Dated: \_\_\_\_\_

\_\_\_\_\_  
Signature  
Typed Name: \_\_\_\_\_  
Title: \_\_\_\_\_  
Contractor: \_\_\_\_\_

**IRAN CONTRACTING ACT CERTIFICATION**  
**(Public Contract Code sections 2202-2208)**  
**(To be Executed by Bidder and Submitted With Bid)**

As required by Public Contract Code (“PCC”) section 2204 for contracts of \$1,000,000 or more, please insert bidder’s or financial institution’s name and Federal ID Number (if available) and complete **one** of the options below. Please note that California law establishes penalties for providing false certifications, including civil penalties equal to the greater of \$250,000 or twice the amount of the contract for which the false certification was made; contract termination; and three-year ineligibility to bid on contracts. (PCC §2205.)

**OPTION #1 - CERTIFICATION**

I, the official named below, certify I am duly authorized to execute this certification on behalf of the bidder/financial institution identified below, and the bidder/financial institution identified below is **not** on the current list of persons engaged in investment activities in Iran created by California Department of General Services (“DGS”) and is not a financial institution extending twenty million dollars (\$20,000,000) or more in credit to another person/bidder, for 45 days or more, if that other person/bidder will use the credit to provide goods or services in the energy sector in Iran and is identified on the current list of persons engaged in investment activities in Iran created by DGS. (PCC §2204(a).)

<i>Bidder Name/Financial Institution (Printed)</i>	<i>Federal ID Number (or n/a)</i>
<i>By (Authorized Signature)</i>	
<i>Printed Name and Title of Person Signing</i>	
<i>Date Executed</i>	<i>Executed in</i>

**OPTION #2 – EXEMPTION**

Pursuant to Public Contract Code sections 2203(c) and (d), a public entity may permit a bidder/financial institution engaged in investment activities in Iran, on a case-by-case basis, to be eligible for, or to bid on, submit a proposal for, or enters into or renews, a contract for goods and services. If you have obtained an exemption from the certification requirement under the Iran Contracting Act, please fill out the information below, and attach documentation demonstrating the exemption approval.

<i>Bidder Name/Financial Institution (Printed)</i>	<i>Federal ID Number (or n/a)</i>
<i>By (Authorized Signature)</i>	
<i>Printed Name and Title of Person Signing</i>	<i>Date Executed</i>

**NONCOLLUSION DECLARATION**  
**TO BE EXECUTED BY BIDDER AND SUBMITTED WITH BID**

Owner: **Antelope Valley Union School District**

Contract for: **Bid# 15/23-24 Desert Winds, Eastside, and R. Rex Parris High Schools Re-Roofs**

The undersigned declares:

I am the \_\_\_\_\_ of \_\_\_\_\_, the party making the foregoing bid.

The bid is not made in the interest of, or on behalf of, any undisclosed person, partnership, company, association, organization, or corporation. The bid is genuine and not collusive or sham. The bidder has not directly or indirectly induced or solicited any other bidder to put in a false or sham bid. The bidder has not directly or indirectly colluded, conspired, connived, or agreed with any bidder or anyone else to put in a sham bid, or to refrain from bidding. The bidder has not in any manner, directly or indirectly, sought by agreement, communication, or conference with anyone to fix the bid price of the bidder or any other bidder, or to fix any overhead, profit, or cost element of the bid price, or of that of any other bidder. All statements contained in the bid are true. The bidder has not, directly or indirectly, submitted his or her bid price or any breakdown thereof, or the contents thereof, or divulged information or data relative thereto, to any corporation, partnership, company, association, organization, bid depository, or to any member or agent thereof, to effectuate a collusive or sham bid, and has not paid, and will not pay, any person or entity for such purpose.

Any person executing this declaration on behalf of a bidder that is a corporation, partnership, joint venture, limited liability company, limited liability partnership, or any other entity, hereby represents that he or she has full power to execute, and does execute, this declaration on behalf of the bidder.

I declare under penalty of perjury under the laws of the State of California that the foregoing is true and correct and that this declaration is executed on \_\_\_\_\_, 20\_\_, at \_\_\_\_\_ [city], \_\_\_\_\_ [state].

\_\_\_\_\_  
Signature

\_\_\_\_\_  
Print Name

**PRIME BIDDER CERTIFICATION OF DISABLED VETERAN BUSINESS ENTERPRISE PARTICIPATION**

*To be completed by the Prime Bidder*

<b>PART I – IDENTIFICATION INFORMATION</b>		
BIDDER'S NAME	BUSINESS ADDRESS	TELEPHONE NUMBER
SCHOOL DISTRICT	COUNTY	APPLICATION NO.

**PART II – METHOD OF COMPLIANCE WITH DVBE PARTICIPATION GOALS** – Include this form and any other applicable documents listed in this table with your bid/proposal. Read the three columns in the table below as sentences from left to right. Check the appropriate box to indicate your method of committing the contract dollar amount.

**NOTE:** *Architectural, engineering, environmental, land surveying or construction management firms must indicate their method of compliance by marking the appropriate box A, B, C, or D after selection by the District and before the contract is signed.*

<b>YOUR BUSINESS ENTERPRISE</b>	<b>AND YOU</b>	<b>AND YOU</b>
<b>A.</b> <input type="checkbox"/> <i>is Disabled Veteran owned and your forces, will perform at least 3 percent of this contract</i>	<i>will include a copy of your DVBE letter from the Office of Small Business and Disabled Veteran Business Enterprise Services (OSDS).</i>	
<b>B.</b> <input type="checkbox"/> <i>is Disabled Veteran owned but is unable to perform the 3 percent of this contract with your forces</i>	<i>will use DVBE subcontractors/ suppliers to bring the contract participation to at least 3 percent</i>	<i>will include a copy of each DVBE's letter from OSDS (including yours, if applicable).</i>
<b>C.</b> <input type="checkbox"/> <i>is not Disabled Veteran owned</i>	<i>will use DVBE subcontractors/ suppliers for at least 3 percent of this contract</i>	
<b>D.</b> <input type="checkbox"/> <i>is unable to meet the required participation goals</i>	<i>will complete a Good Faith Effort to obtain DVBE participation</i>	<i>will include the Prime Bidder's Good Faith Effort Worksheet.</i>

**Note:** An Office of Small Business and Disabled Veteran Business Enterprise Services (OSDS) letter must be attached for each DVBE participating in the contract. The DVBE letter is obtained by application through the OSDS and must be provided at the time of bid opening. If the letter is not provided, the bid may be deemed nonresponsive and may be ineligible for award of the contract.

*Continued on reverse side*

**PART III – DVBE DOLLAR PARTICIPATION OF BID/PROPOSAL** – *Architectural, engineering, environmental, land surveying or construction management firms complete this part **after** selection by the district and before the contract is signed.*

Show deductive alternate(s) in parenthesis. For more alternates/base bids, use a separate page to show items.

- A. If your business enterprise is a DVBE, list in the appropriate column the total dollar amount of your bid to be performed by your own participation.
- B. List all your DVBE subcontractors/suppliers. Enter in the appropriate column the dollar amount for each of your subcontractors/suppliers.
- C. Enter the total of Lines A and B for each column.
- D. Enter the dollar amount of the bid/proposal to be performed by **non-DVBE** firms. Note: This line is the sum of the prime and subcontractor(s) **non-DVBE** dollar participation.
- E. Enter the sum of the column totals from Line C and Line D. Note: Please be aware that the final determination of DVBE compliance is made based on the contract amount resulting from the district’s acceptance or rejection of alternates.

	<b>BASE BID/PROPOSAL</b>	<b>ALTERNATE #1</b>	<b>ALTERNATE #2</b>	<b>ALTERNATE #3 OR BASE BID B</b>	<b>ALTERNATE #4 OR BASE BID C</b>	<b>ALTERNATE #5 (Modernization or Reconstruction Only)</b>
A. Prime Bidder, <i>if DVBE (own participation)</i>	\$	\$	\$	\$	\$	\$
B. DVBE Subcontractor or Supplier						
1.						
2.						
3.						
4.						
C. Subtotal (A & B)						
D. Non-DVBE						
E. Total Bid						

**PRIME BIDDER GOOD FAITH EFFORT WORKSHEET**

*This worksheet is to be used to assist the Prime Bidder in meeting the 3% DVBE participation goal*

BIDDER'S NAME	BUSINESS ADDRESS	CONTACT PERSON
TELEPHONE NUMBER	OWNER	COUNTY

**GENERAL INSTRUCTIONS:**

This worksheet is to be used to assist you in meeting the 3 percent DVBE participation goal. If specific information is not provided for Parts I through III, you do not meet the test of the "Good Faith Effort" and cannot so certify. If you are qualifying based on a "Good Faith Effort" you must include this form with your bid/proposal to the Owner.

**PART I – CONTACTS**

To identify DVBE subcontractors/suppliers for participation in your bid/proposal, contact must be made with each of the following categories. It is recommended that you contact several DVBE organizations.

CATEGORY	TELEPHONE NUMBER	DATE CONTACTED	PERSON CONTACTED
1. Owner			
2. Office of Small Business and Disabled Veteran Business Enterprise Services (OSDS). OSDS provides assistance locating DVBEs at <a href="https://caleprocure.ca.gov/pages/PublicSearch/supplier-search.aspx">https://caleprocure.ca.gov/pages/PublicSearch/supplier-search.aspx</a> .	(916) 375-4940		
3. DVBE Organizations ( <i>List</i> ):			
4. Write "recorded message" in this column, if applicable.			



**PART II – ADVERTISEMENTS** You must make at least two (2) advertisements, one (1) in a paper that focuses on DVBE and one (1) in a trade paper. Advertisements should be published at least 14 days prior to bid/proposal opening; if you cannot advertise 14 days prior, advertise as soon as possible and provide an explanation. (Advertisements must be published in time to allow for a reasonable response). Advertisements must include that your firm is seeking DVBE participation, the project name and location, your firm’s name, your firm’s contact person, and phone number.

*Attach copies of advertisements to this form.*

FOCUS/TRADE PAPER NAME	CHECK ONE		DATE OF ADVERTISEMENT
	TRADE	FOCUS	

**PART III – DVBE SOLICITATIONS** List DVBE subcontractors/suppliers that were invited to bid. Use the following instructions to complete the remainder of this section (read the three columns as a sentence from left to right). If you need additional space to list DVBE solicitations, please use a separate page and attach to this form.

IF THE DVBE.....	THEN.....	AND.....
Was selected to participate	Check "yes" in the "SELECTED" column, include the applicable dollar amount in Part III of the Prime Bidder Certification	Include a copy of their DVBE letter from OSDs.
Was <b>not</b> selected to participate	Check "no" in the "SELECTED" column	State why in the "REASON NOT SELECTED" column.
Did not respond to your solicitation	Check the "NO RESPONSE" column	

DISABLED VETERANS BUSINESS ENTERPRISES CONTACTED	SELECTED		REASON NOT SELECTED <i>This section must be completed</i>	NO RESPONSE
	YES	NO		

**IMPORTANT NOTE:**

Please be aware that certification of the "Good Faith Effort" may only be made if you fully complete Parts I, II, and III on both sides of this form. A copy of this form must be retained by you and may be subject to a future audit.

**CERTIFICATION**

I, \_\_\_\_\_ certify that I am the bidder's Chief Executive Officer and that I have made a diligent effort to ascertain the facts with regard to the representations made herein. In making this certification, I am aware of Section 12650 et seq. of the Government Code providing for the imposition of treble damages for making false claims.

SIGNATURE OF CHIEF EXECUTIVE OFFICER	DATE
--------------------------------------	------

**Sufficient Funds Declaration**  
**(Labor Code section 2810)**

**To Be Executed by Bidder and Submitted with Bid**

Owner: **AVUHSD**

Contract for: **Bid# 15/23-24 Desert Winds, Eastside, and R. Rex Parris High Schools Re-Roofs**

I, \_\_\_\_\_, declare that I am the \_\_\_\_\_ of \_\_\_\_\_, the entity making and submitting the bid for the above Project that accompanies this Declaration, and that such bid includes sufficient funds to permit \_\_\_\_\_ [insert name of entity] to comply with all local, state or federal labor laws or regulations during the performance of the Contract for the Project, including payment of prevailing wage, and that \_\_\_\_\_ [the entity] will comply with the provisions of Labor Code section 2810(d) if awarded the Contract.

I declare under penalty of perjury under the laws of the State of California that the foregoing is true and correct and executed on \_\_\_\_\_20\_\_, at \_\_\_\_\_[city], \_\_\_\_\_[state].

Date: \_\_\_\_\_

\_\_\_\_\_  
Signature

Print Name: \_\_\_\_\_

Print Title: \_\_\_\_\_

**WORKERS' COMPENSATION CERTIFICATE**

Labor Code Section 3700, in relevant part, provides:

"Every employer except the state shall secure the payment of compensation in one or more of the following ways:

(a) By being insured against liability to pay compensation in one or more insurers duly authorized to write compensation insurance in this state.

(b) By securing from the Director of Industrial Relations a certificate of consent to self-insure either as an individual employer or as one employer in a group of employers. Said certificate may be given upon furnishing proof satisfactory to the Director of Industrial Relations of ability to self-insure and to pay any compensation that may become due to his or her employees, ... "

I am aware of the provisions of the Labor Code Section 3700 which require every employer to be insured against liability for workers' compensation or to undertake self-insurance in accordance with the provisions of that code, and I will comply with such provisions before commencing the performance of the work of this contract. I shall supply the Owner with certificates of insurance evidencing that Workers' Compensation Insurance is in effect and providing that the Owner will receive thirty (30) days' notice of cancellation.

\_\_\_\_\_  
Name of Contractor

\_\_\_\_\_  
Signature

\_\_\_\_\_  
Print Name

\_\_\_\_\_  
Date

(In accordance with Article 5 (commencing at Section 1860), Chapter 1, Part 7, Division 2 of the Labor Code, the above certificate must be signed and filed with the awarding body prior to performing any work under the contract.)

**ROOF PROJECT CERTIFICATION**

(Public Contract Code §3006(a) and (b))

I, \_\_\_\_\_ [name], \_\_\_\_\_ [name of employer], certify that I have not offered, given, or agreed to give, received, accepted, or agreed to accept, any gift, contribution, or any financial incentive whatsoever to or from any person in connection with the roof project contract. As used in this certification, "person" means any natural person, business, partnership, corporation, union, committee, club, or other organization, entity, or group of individuals. Furthermore, I, \_\_\_\_\_ [name], \_\_\_\_\_ [name of employer], certify that I do not have, and throughout the duration of the contract, I will not have, any financial relationship in connection with the performance of this contract with any architect, engineer, roofing, consultant, materials manufacturer, distributor, or vendor that is not disclosed below.

I, \_\_\_\_\_ [name], \_\_\_\_\_ [name of employer], have the following financial relationships, with an architect, engineer, roofing consultant, materials manufacturer, distributor, or vendor, or other person in connection with the following roof project contract:

\_\_\_\_\_  
[name and address of building, contract date and number]

\_\_\_\_\_  
[name and address of building, contract date and number]

\_\_\_\_\_  
[name and address of building, contract date and number]

\_\_\_\_\_  
[name and address of building, contract date and number]

I certify that to the best of my knowledge, the contents of this disclosure are true, or are believed to be true.

\_\_\_\_\_ Signature \_\_\_\_\_ Date

\_\_\_\_\_ Print Name

\_\_\_\_\_ Print Name of Employer

May 7, 2024

Mr. Scott Fish  
Antelope Valley Union High School District  
44900 Division Street  
Lancaster, CA 93535

RE: 07 54 19 33 – Single Ply PVC Roofing  
Desert Winds High School

Dear Mr. Fish,

Enclosed please find the specifications you requested, based upon inspection of existing roofing and conditions at the referenced job site.

A 60-mil fully adhered PVC system has been specified on the low slope roof, which includes a 20-year no dollar limit (NDL) manufacturer warranty. The new PVC roof system shall meet title 24 and Class A requirements. Standard installation procedures have been outlined, as well as several customized instructions in these sections.

NRC can meet with selected contractors and manufacturer representatives in a Pre-Bid Walk to clarify the specifications and answer any questions. Subsequently, an addendum will be implemented. Please coordinate the job walk date with this office.

If you have any questions or need additional assistance, please call. Your use of our services is very much appreciated.

Sincerely,  
Edmund Hadvina  
Senior Consultant

# ANTELOPE VALLEY UNION HIGH SCHOOL DISTRICT

**Desert Winds High School  
415 East Kettering Street  
Lancaster, CA 93535**

## **Section 07 54 19 33**

### **Single Ply PVC Roofing**

#### **PART I GENERAL**

##### 1.01 SCOPE

- A. All roofing areas, flashings, penetrations, and equipment shall be included in the work under this section.
  
- B. Furnish materials and perform labor as specified and as necessary to complete the specified reroofing, including but not limited to these major items:
  - 1. Removal of and discarding existing built up roofing and aggregate down to the substrate.
  - 2. Low slope roof installation with white California Title 24, 60-mil single ply smooth PVC membrane adhered with low VOC adhesive over ½” Dens Deck Prime roof cover board.
  - 3. Include manufacturer 20-year NDL warranty.
  - 4. Preparation of deck substrate, which includes necessary repair.
  - 5. Installation of tapered insulation crickets as required correcting inadequate drainage.
  - 6. Installation of polyisocyanurate rigid insulation to match existing.
  - 7. Water testing of existing drains.
  - 8. Installation of new 24-gauge Kynar coated sheet coping metal at top of parapet walls. Alternate to save existing coping metal for reuse.
  - 9. NOTE: Inspection services shall be utilized by the Antelope Valley Union High School District (AVHSD) to oversee the work.
  - 10. NOTE: Tear off and disposal of asbestos-containing materials must be performed in accordance with governing codes and regulations.
  - 11. NOTE: The entire roof surface shall be washed after completion of installation.
  - 12. NOTE: Roofing contractor shall be responsible for necessary due diligence in terms of roof test cut samples and existing conditions to avoid unforeseen conditions and change orders.
  - 13. NOTE: Roofing contractor shall be responsible for damaged mechanical items, such as HVAC, ducting, exhaust fans during roof renovation and ensuring that all HVAC, electrical, etc. is water tight and functioning properly.
  - 14. NOTE: Roofing contractor shall be responsible for current governing codes, such as insulation, inspection, and permits.

##### 1.02 PERFORMANCE REQUIREMENTS

- A. General: Provide and install specified membrane and its base flashings that remain watertight, do not pond water, resist thermal movement and resist exposure to weather without failure.

##### 1.03 REFERENCES

- A. American Society for Testing & Materials (ASTM)

- B. Federal Specifications (FS)
  - C. Underwriters Laboratories (UL)
  - D. Factory Mutual (FM)
- 1.04 QUALITY ASSURANCE
- A. Compliance to Specifications
    1. Roofing foreman shall always have a copy of these specifications on the job during application and shall refer to same for proper application methods.
    2. Whenever specification items found herein are less stringent than the roofing manufacturer's published specifications, the manufacturer's minimum *requirements* shall be followed. Antelope Valley Union High School District (AVHSD) will invite the roofing manufacturer's representative to the pre-construction conference, and the representative will visit the work in progress.
    3. Written specifications submitted to the roofing contractor do not relieve the roofing contractor of his obligation to thoroughly check the size, substrate, slope, and other conditions of the roof.
    4. Contractor must provide submittals of roofing materials including MSDS information at the pre-construction conference, for the purpose of review and approval by NRC prior to the start of the work.
  - B. Regulatory Requirements
    1. Fire Regulations: Roofing contractor shall be responsible for meeting fire regulations. A certified fire extinguisher of adequate size shall be located on the roof near the work.
    2. Roof Membrane Attachment: Membrane attachment shall conform to roofing manufacturer, Uniform Building Code, Factory Mutual and shall include upgrades to modify attachment for special requirements in area where building is located.
      - a. Minimum attachment shall conform to FM I-90.
    3. Safety barriers shall be erected around chute to dumpster for demolition, and ladder to roof level. Warning tape shall be placed at material storage location and roof edges where roofing is in progress.
    4. Roofing contractor shall be responsible to meet OSHA and Cal-OSHA requirements for safety of all involved and around buildings.
    5. Hazardous materials shall be disposed of according to government regulations.
    6. Roofing contractor shall obtain any required permits from the City of Lancaster as necessary.
  - C. Quality Control
    1. All work is to be performed under the full-time observation of National Roofing Consultants (NRC), 118 Lincoln Ave, Pomona CA 91767 (909) 620-0177.
    2. Responsibility for Payment: Antelope Valley Union High School District (AVHSD) will provide and make payment to NRC for all daily observation; however, the roofing contractor will be responsible by whatever arrangements are mutually agreed upon between the roofing contractor and the Antelope Valley Union High School District (AVHSD) for observation costs incurred as the result of unapproved time delays and observation costs incurred when work is not performed as scheduled.
    3. As designated by the NRC representative, 1-1/2" sample welds shall be taken by roofing contractor each morning and afternoon prior to commencing application. Areas from which test cuts have been taken shall be repaired in manner directed by NRC representative and manufacturer representative as part of the work.
    4. Coordination
      - a. Job Conference: Prior to commencement of work the Antelope Valley Union High School District (AVHSD) shall arrange a conference to be held at the job site to review specifications and to walk the deck.

Roofing contractor, manufacturer representative, Antelope Valley Union High School District (AVHSD), and NRC representative are to be in attendance.

- b. Notification: The roofing contractor shall give 72 hours prior notice to consulting service before starting application and shall notify the same each time work is to be performed. Lack of notification of work schedule changes shall result in compensation for NRC's lost time and expenses at the contractor's expense.
- c. Final/Punch List
  - (1) Consulting service and the Antelope Valley Union High School District (AVHSD) shall be notified upon completion of roof and shall return and do final/punch list.

D. Change Orders

- 1. If a bidder sees work that bidder feels is part of the scope, but feels is not listed in specifications, bidder shall raise that question seven (7) days prior to bid opening. Antelope Valley Union High School District (AVHSD) will then clarify the scope or specification question at that time, or by addendum to the specifications. Attendance at the pre-bid conference is mandatory.
- 2. The Quality Control Observer does not have authority to permit specification changes. Any information or assistance provided by the same does not relieve the roofing contractor of strict compliance with specifications, drawings, and material manufacturer's requirements. NRC does not assume responsibility, such as water damage, which is normally the roofing contractors. Bidders are required to meet the specifications at time of bid. The work will be observed according to the specifications.
- 3. No change orders covering cost additions to meet manufacturer's *requirements* will be accepted. The roofing contractor is responsible to meet all manufacturers' *requirements*, which are more stringent than the issued job specifications. Costs to improve existing conditions, i.e. minimum curb height, lead drain flashings; crickets, etc. are to be included in the bid. Compliance with manufacturer *recommendations* shall apply only as directed by these specifications. The contractor shall identify those items that apply with the material manufacturer.
- 4. **Any variance from the specifications shall be by written change order or written instruction from Antelope Valley Union High School District (AVHSD) only. Work in question shall terminate until authorization to proceed has been given.**
- 5. Bidder wishing to submit an alternate or equal material must do so seven (7) days prior to bid due date. Failure to do so will disqualify bid. Include written proof in the form of ASTM and FS number, type, UL ratings and manufacturer's specification number.
- 6. When a make or trade name is specified, it shall indicate the standard required. Contractor proposing an alternate material shall submit the following:
  - a. Written application with explanation of why it should be considered.
  - b. Manufacturer's literature and samples of requested substitutions.
  - c. Three (3) job references of applications 5 years old or older available for inspection within 100 miles of project where substitutions were used under similar conditions.

E. Roofing Contractor's Qualifications

- 1. Bidder must include, with bid, a letter from manufacturer stating that bidder is certified to install manufacturer's product.
- 2. Job Experience: The roofing contractor installing the system shall have a minimum of two (2) years experience successfully applying the same or similar materials. The roofing contractor shall only use skilled workmen who are familiar with the products and application methods.



- F. Coordination
  - 1. Contractor is required to attend a pre-construction conference with the consultant, Antelope Valley Union High School District (AVHSD) and material manufacturer representative, which will establish start date.
  
- 1.05 SUBMITTALS
  - A. Necessary items pertaining to Section 1.04A4.
  - B. Necessary items pertaining to Section 1.04E1.
  
- 1.06 DELIVERY, STORAGE AND HANDLING
  - A. Delivery: Deliver all materials in their original containers with seals unbroken and manufacturer label and product identification clearly legible on each package.
  - B. Storage: Store materials at site on pallets and under cover and maintain in dry condition.
  
- 1.07 PROJECT CONDITIONS
  - A. Moisture: Wet materials shall not be applied nor shall roofing application proceed when moisture is on roof or deck.
  - B. Water tightness: Roofing contractor shall always be responsible for maintaining roof in a watertight condition. Interior damage caused by leakage during roof application shall be the responsibility of the roofing contractor.
  - C. Building Protection
    - 1. Tear-off and debris transit must not disturb operations of the building. Enclosed chutes and other methods shall be used to contain dust and debris.
    - 2. The building exterior must be protected from damage, markings, or spillage using tarpaulins or protective sheeting.
    - 3. The contractor will be responsible for damage to grass, shrubs, trees, or grounds including curbs and side walks. Protective covers shall be utilized under any equipment that would damage or stain any surface.
  - D. Clean Up: Premises shall be kept clean **daily** during application and left clean when roof is completed.
  - E. Contractor to provide portable toilet facilities.
  - F. Job Decorum: Dogs, drugs, alcohol, and radio playing are prohibited.
  
- 1.08 SEQUENCING AND SCHEDULING
  - A. Roofing contractor shall inform Antelope Valley Union High School District (AVHSD) and receive approval for start date, work duration time, material and equipment storage area and vehicle, equipment, and pedestrian traffic pattern.
  
- 1.09 GUARANTEE
  - A. Roofing contractor shall provide to Antelope Valley Union High School District (AVHSD) a written guarantee against defects of workmanship and to maintain roof in a watertight condition for a period of five (5) years from final acceptance of product by Antelope Valley Union High School District (AVHSD).
  - B. Manufacturer's Warranty
    - 1. Provide manufacturer's 20-year NDL warranty to provide repairs or correction of roof stemming from material defects, contractor workmanship and ordinary wear and tear of elements.
    - 2. Warranty shall not exclude ponding water of any kind.

**PART II PRODUCTS**

2.01 MATERIALS

A. Membrane

1. The roofing system shall be adhered with a low VOC bonding adhesive for use with reinforced polyvinyl chloride (PVC) felt back membrane. PVC membrane shall be installed over 1/2" Dens deck prime roof cover board. Material components shall all be from one (1) manufacturer, shall have a U/L Class A fire rating, and shall be manufacturer's current published specification.
2. Color
  - a. Low Slopes: White
  - b. Parapet Walls: White

B. Approved Manufacturers and Products

1. Manufacturers
  - a. Carlisle: FleeceBack PVC Minimum Thickness 60 Mil  
Arturo Ortiz (818) 813-4082
  - b. Sika Sarnafil: S327 Feltback 60 Mil  
Rob Stoeckinger (310) 883-4952
  - c. Soprema: Sentinel P150 HFB  
Missy McLain (805) 216 6630
  - d. IB Roof Systems: 60 mil PVC Feltback  
Jeremy Roberts (909) 273-4796
  - e. Or NRC approved equal
2. Products
  - a. 60-mil minimum thickness PVC membrane
  - b. Low VOC bonding Adhesive
  - c. 1/2" Dens Deck Prime roof cover board
  - d. Polyisocyanurate rigid insulation to match existing
  - e. NRC approved equal prior to bidding

C. Summary of Materials: Materials shall not be less than the following per 100 square feet.

1.	1/2" Dens Deck Prime roof cover board	096.0 lbs
2.	Adhesive	011.0 lbs
3.	Single ply membrane	032.0 lbs
	<b>TOTAL APPROXIMATE WEIGHT</b>	<b>139.0 lbs</b>

D. Standards: All materials shall conform to the following

1. Low Slope PVC Felt Back Membrane: 60 mils (minimum) white, heat-welded polyvinyl chloride sheet roofing membrane.
2. Polyisocyanurate rigid insulation to match existing
3. Roof Cover board: 1/2" Dens Deck Prime roof cover board.
4. Membrane Sealant: One-part polyurethane.
5. Membrane Adhesive: Low VOC bonding adhesive.
6. Termination Bar: 16-gauge extruded aluminum.
7. Flashing Membrane: PVC membrane of specified thickness to be used for flashing.
8. Miscellaneous Materials: Materials required or supplied by the manufacturer.
9. Metal/Counter Flashing: 24-gauge Kynar coated sheet metal.
10. Tapered Insulation: Tapered perlite or polyisocyanurate, minimum 1/2" per foot or twice the roof slope, whichever is greater.
11. Coping Lap Sealant: Elastomeric silicone, one-part; Dow 795, GE Silpruf SCS 2000 or Sika WS-295

12. Penetration Seal: Prefabricated polymer curb with self-leveling, pourable sealant. Chem Curb by Chem Link, (800) 826-1681 or Carlisle specified pourable fluid-applied sealant for unusual penetrations.
13. Insulation and Underlayment Adhesive: Manufacturers recommended two-part low-rise foam adhesive.
14. Clad Metal Edge: 25-gauge, sheet metal edge with factory-applied PVC coating, 4" flange and face with 3" drip edge.

### **PART III EXECUTION**

#### **3.01 ASBESTOS REMOVAL**

- A. Removal and disposal of incidental asbestos-containing materials shall be performed in accordance with governing codes and regulations.

#### **3.02 PREPARATION OF SURFACES**

- A. Repair substrate as necessary.
- B. Assure substrate is smooth and clean.
- C. Provide water cutoffs or otherwise complete terminations and base flashings and seals to prevent water from entering completed work at the end of the day or when rain is eminent. Remove and discard temporary seals before beginning work on adjoining roofing.

#### **3.03 UNUSED JACKS, PIPES, PADS, ETC.**

- A. Remove from roof and level off. Fill large opening flush with deck level. Cover smaller holes with 24-gauge sheet metal, nailed solid. It is the roofing contractor's responsibility to identify all items to be removed before submitting bid.

#### **3.04 EXAMINATION**

- A. Verify that roof penetrations are in place and secured.
- B. Verify that wood blocking, curbs and nailers are securely anchored to the substrate.
- C. Verify that substrate is visibly dry and free of moisture.
- D. Verify that contaminants that will impair adhesion of roofing components have been removed.
- E. Proceed with installation only after unsatisfactory conditions have been corrected.

#### **3.05 OUTLETS**

- A. Drains
  1. Remove scupper flashings and replace with new 25-gauge, G-90 sheet metal with factory-applied PVC coating.
  2. Remove drain domes and clamping rings. Inspect for rust damage and replace any compromised domes that may not last 20 years.
  3. Prepare base per manufacturer's requirements, then apply roofing membrane. Install clamping ring and cover. NOTE: The roofing membrane shall smoothly transition with the drains and shall be applied in such a manner that water will not dam up.

#### **3.06 FLASHINGS**

- A. Pipe or Conduit Penetrations
  1. Remove and discard metal flashings and apply aluminum tape around penetrations if required or use cone or prefabricated boot. Seal tape with PVC flashing

membrane and clamp off top with a hose clamp. Seal the clamp with specified sealant.

- B. Multiple (nested) Penetrations
    - 1. At multiple penetrations, provide manufacturer's one-part pourable sealant or install Chem Curb penetration seals installed per manufacturers' requirements.
  - C. Sheet Metal Roof Vents
    - 1. Replace existing roof vents with new PVC clad metal vents having 6" wide flanges fabricated from clad metal. Secure vent flanges to with manufacturer's approved fasteners at 4" O.C. Heat weld field sheets to flange with 2" minimum wide weld.
    - 2. Install rodent screens at all openings larger than 3".
- 3.07 PARAPETS
- A. Walls
    - 1. Install roofing membrane fully adhered, and terminate at top outside edge or counter flashing, and securely attached with approved mechanical fasteners.
  - B. Base Flashings
    - 1. Install (adhere) roofing membrane to the base of the wall, and then secure to deck with termination bar. Install flashing on wall just below the bottom of the upper reglet or curb counter flashing drip edge with proper adhesive. Secure top of flashing with termination bar. Seal top of termination bar and membrane termination point with specified sealant.
  - C. Copings
    - 1. Install new metal copings after application of wall covering complete.
    - 2. Seal external coping laps with a 1/8" thick application of polyurethane sealant straddled across lap, neatly applied, and taped to avoid over application.
- 3.08 INSULATION AND COVER BOARD
- A. Insulation
    - 1. Install tapered insulation crickets at drain side walls. Contractor shall verify where crickets are required or where adverse conditions exist.
    - 2. Install Polyisocyanurate rigid insulation to match existing.
    - 3. Adhere all layers using manufacturers approved adhesive.
    - 4. Adhere 1/2" Dens Deck Prime roof cover board per manufacture's specifications.
    - 5. Do not install wet, damaged, or warped insulation boards.
- 3.09 ROOFING MEMBRANE
- A. The system is to be fully adhered. The smooth membrane is to be broomed and rolled immediately after placement to assure that adhesive has been properly spread (dispersed). Visual indications of adhesive beads (ribbons) or adhesive in general will not be accepted. Adjacent sheets of smooth membrane shall have minimum lap areas of 3" side and 6" end. When machine welding welds shall be 1-1/2", and 2" when hand welding. Welding equipment shall be provided by or approved by manufacturer. All completed welded seams shall be checked after cooling using a round screwdriver or another suitable blunt object. Visible evidence that welding is proceeding acceptably is smoke during the welding process, shiny membrane, and an uninterrupted flow of black material from the edge of completed joints.
- 3.10 SUPPORTS ON ROOF
- A. Replace existing wood pipe or equipment sleepers with new specified pre-manufactured supports. Leave supports standing freely on roof surface on buffer pads of membrane.

3.11 CLEAN-UP/TOUCH-UP/CLOSE-OUT

- A. Paint all new and existing metal (or use Kynar-coated metal), including new counterflashings with specified coating or paint in a minimum of two (2) coats. Color to be designated.
- B. Perform Antelope Valley Union High School District (AVHSD), NRC, and manufacturer final inspections.
- C. Provide manufacturer warranty documentation to Antelope Valley Union High School District (AVHSD).
- D. After final inspections, Antelope Valley Union High School District (AVHSD) shall determine an appropriate time for a complete pressure washing of the membrane. Washing shall be completed with the applicator present to repair any identified problems.
- E. Correct deficiencies or remove membrane that does not comply with manufacturer requirements. Membrane shall be free of damage or any condition that may prohibit or delay warranty implementation.
- F. Clean spillage or traffic marring using cleaning agents and procedures recommended by the manufacturer.
- G. Repair any gouges, scratches, cuts, open laps, etc. as marked by NRC on final inspection.

**END OF SECTION 07 54 19 33**

NATIONAL ROOFING CONSULTANTS

CLIENT: AVHSD  
DATE: MAY 6, 2024

NAME OF BUILDINGS: DESERT WINDS HIGH SCHOOL  
ADDRESS: 415 EAST KETTERING ST., LANCASTER, CA 93535

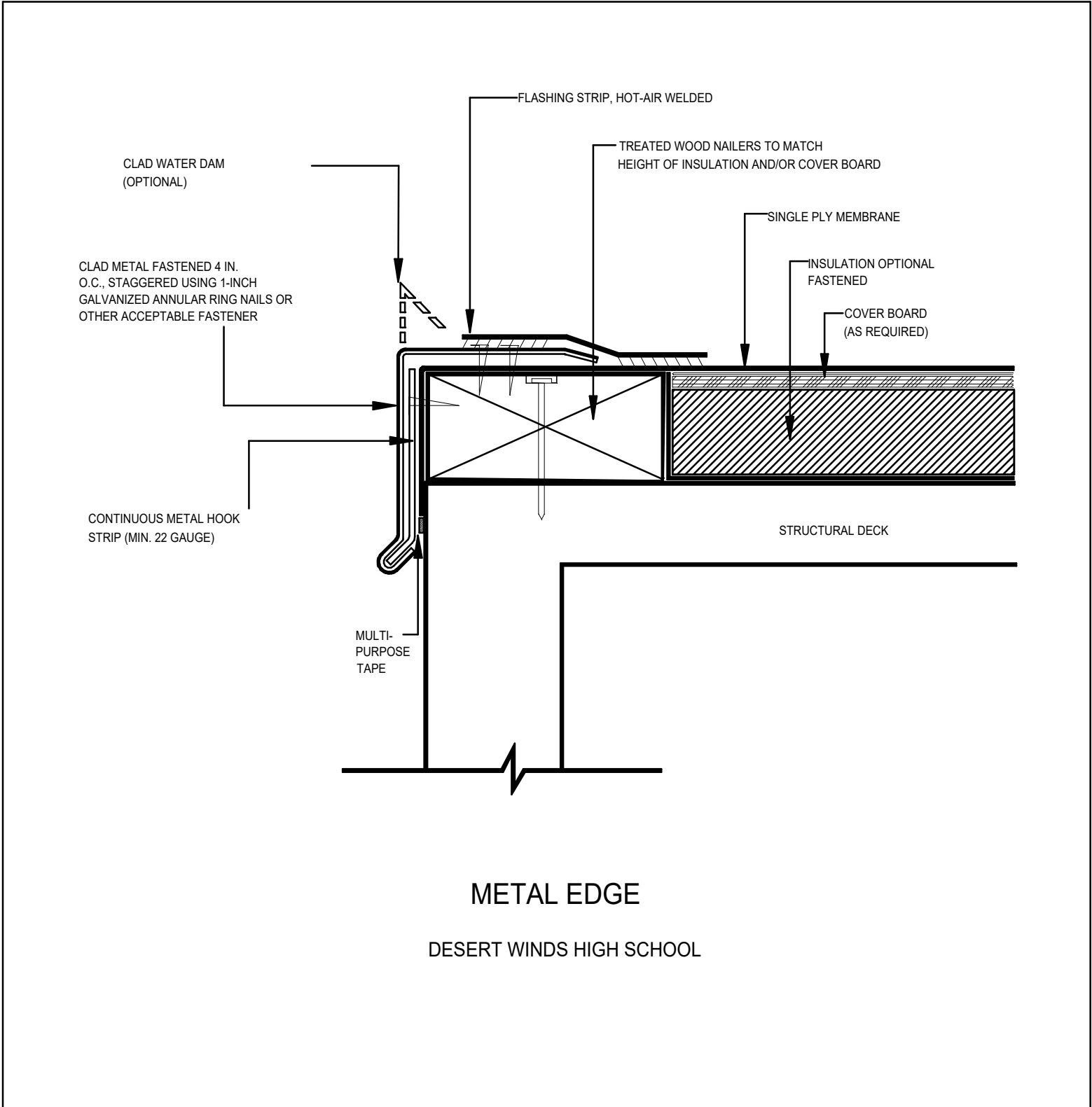

NATIONAL ROOFING CONSULTANTS

CLIENT: AVHSD

NAME OF BUILDINGS:

DESERT WINDS HIGH SCHOOL

DATE: MAY 6, 2024

ADDRESS:

415 E. KETTERING ST., LANCASTER, CA 93535

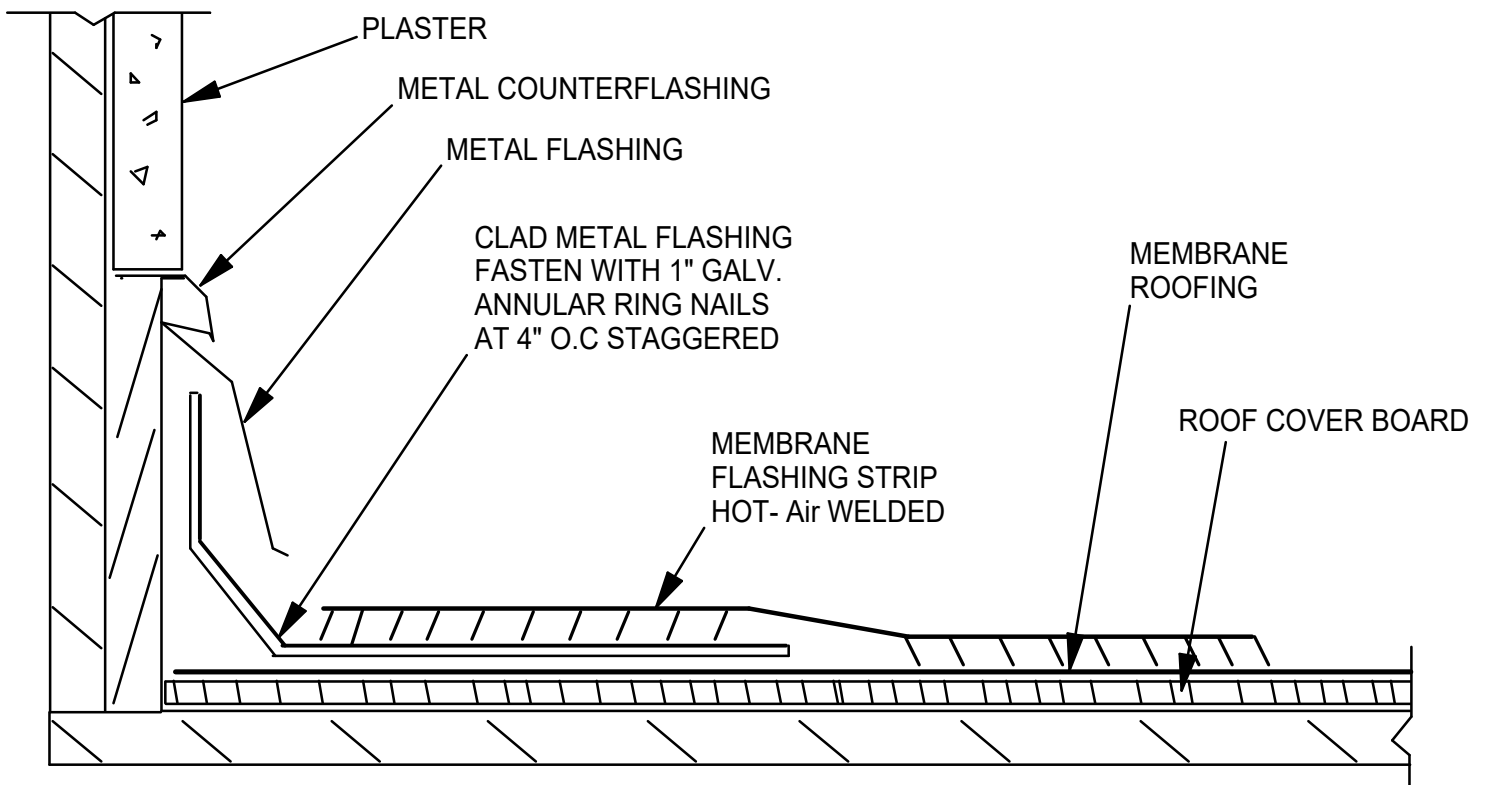

LOW FLASHING DETAIL

DESERT WINDS HIGH SCHOOL

# NATIONAL ROOFING CONSULTANTS

CLIENT: AVHSD

NAME OF BUILDING: DESERT WINDS HIGH SCHOOL

DATE: MAY 6, 2024

ADDRESS: 415 E. KETTERING ST., LANCASTER, CA 93535

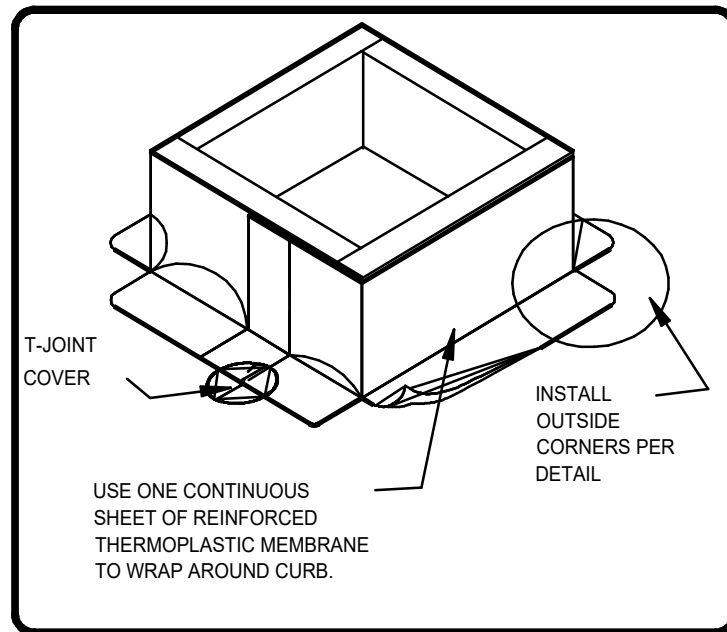
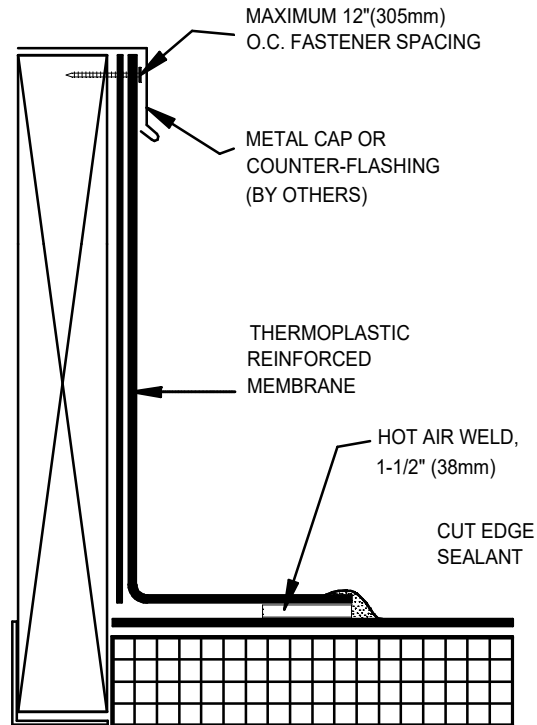

CURB FLASHING

DESERT WINDS HIGH SCHOOL



# NATIONAL ROOFING CONSULTANTS

CLIENT: AVHSD

NAME OF BUILDING: DESERT WINDS HIGH SCHOOL

DATE: MAY 6, 2024

ADDRESS: 415 E. KETTERING ST., LANCASTER, CA 93535

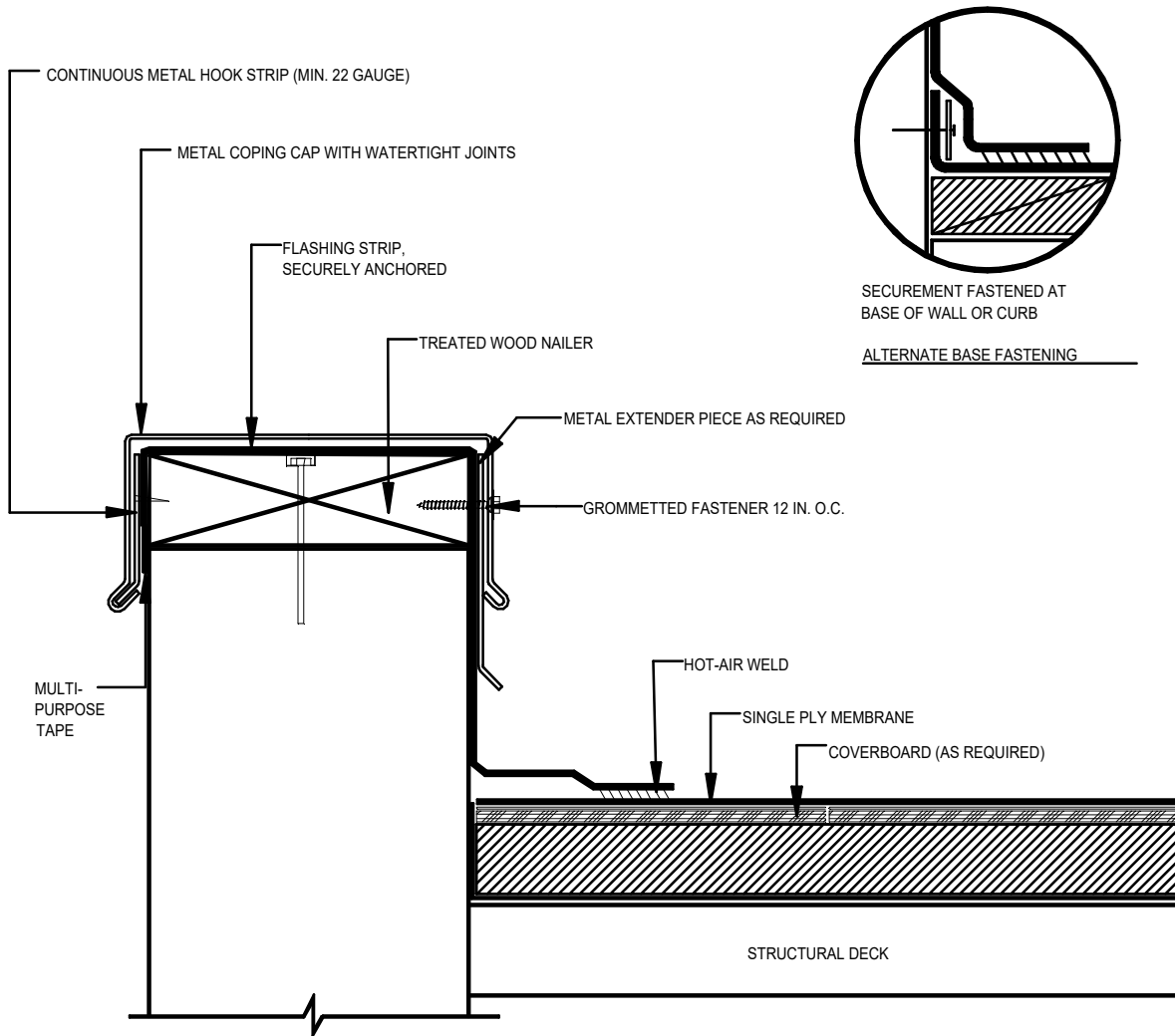

## PARAPET WALL WITH METAL COPING CAP

DESERT WINDS HIGH SCHOOL

# NATIONAL ROOFING CONSULTANTS

CLIENT: AVHSD  
DATE: MAY 6, 2024

NAME OF BUILDING: DESERT WINDS HIGH SCHOOL  
ADDRESS: 415 E. KETTERING ST., LANCASTER, CA 93535

MEMBRANE SPLICE

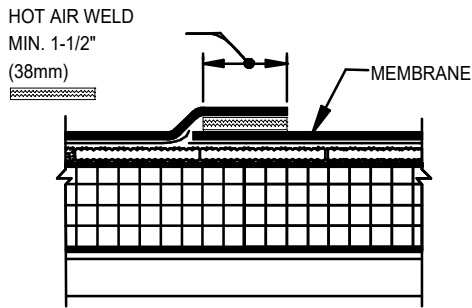

END LAP SPLICE

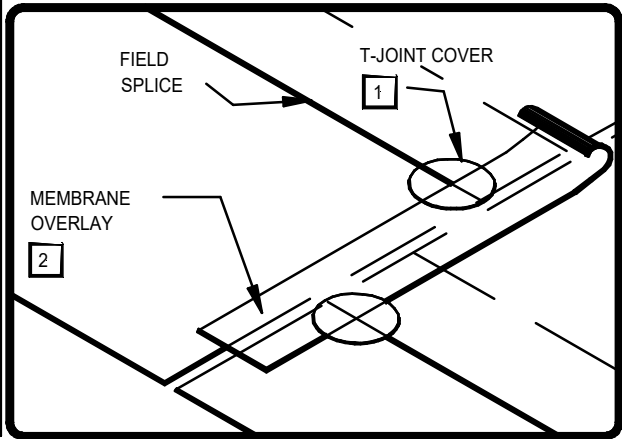
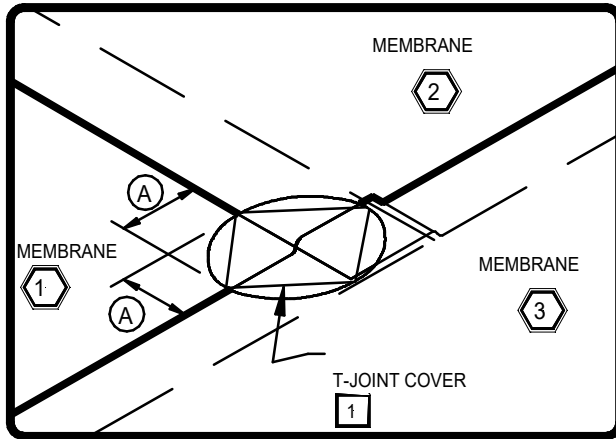
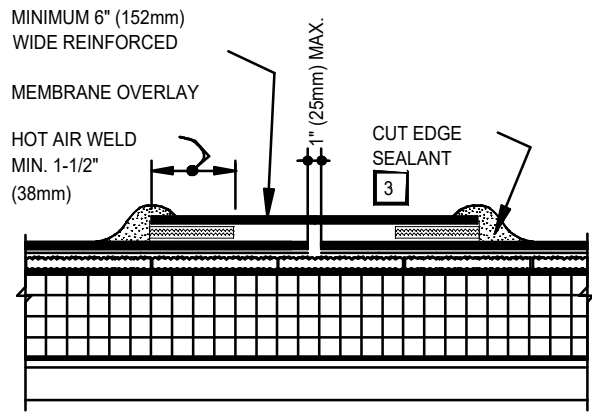

## MEMBRANE SPLICES

DESERT WINDS HIGH SCHOOL

# NATIONAL ROOFING CONSULTANTS

CLIENT: AVHSD

NAME OF BUILDING: DESERT WINDS HIGH SCHOOL

DATE: MAY 6, 2024

ADDRESS: 415 E. KETTERING ST., LANCASTER, CA 93535

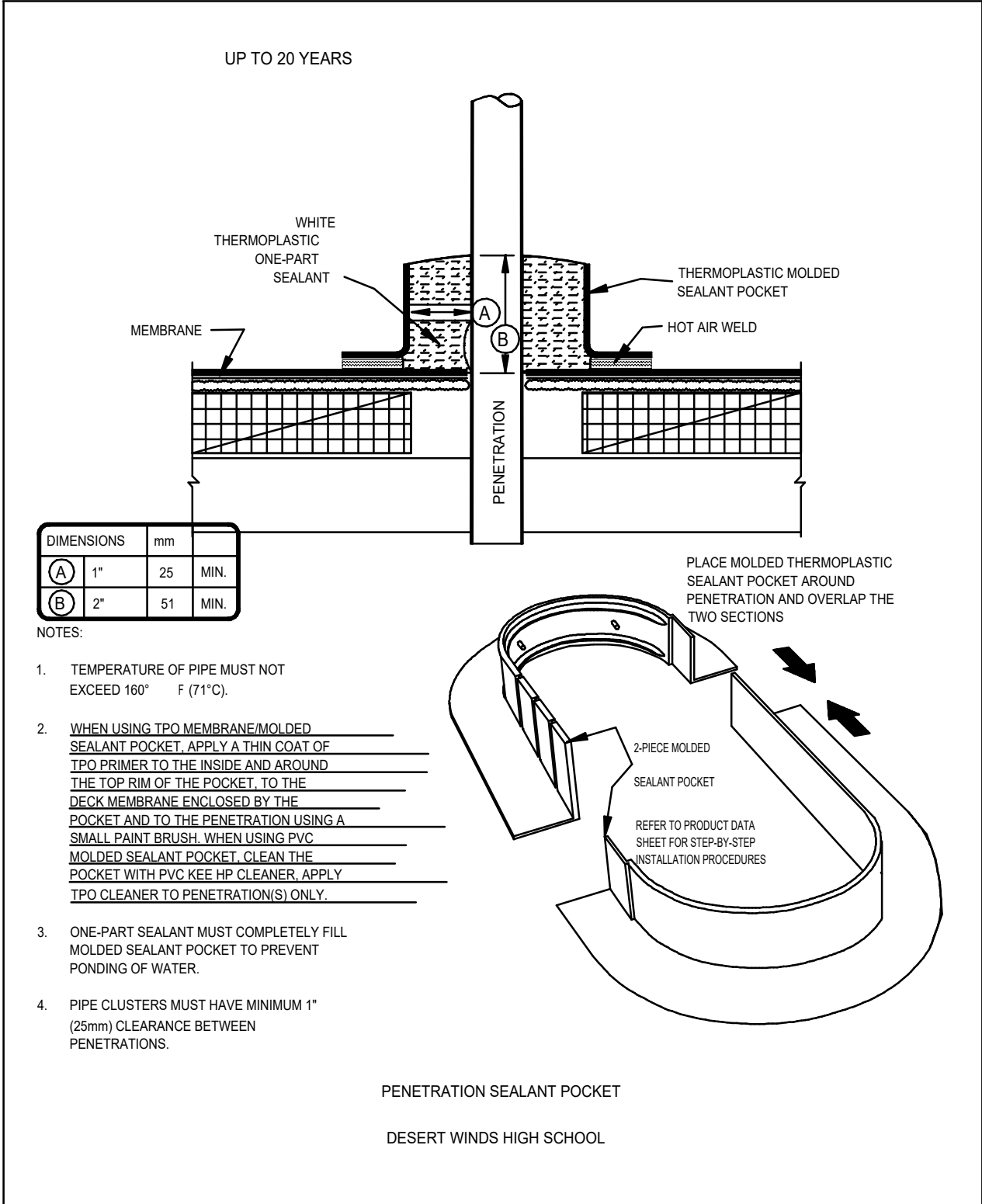

NATIONAL ROOFING CONSULTANTS

CLIENT: AVHSD

NAME OF BUILDING:

DESERT WINDS HIGH SCHOOL

DATE: MAY 6, 2024

ADDRESS:

415 E. KETTERING ST., LANCASTER, CA 93535

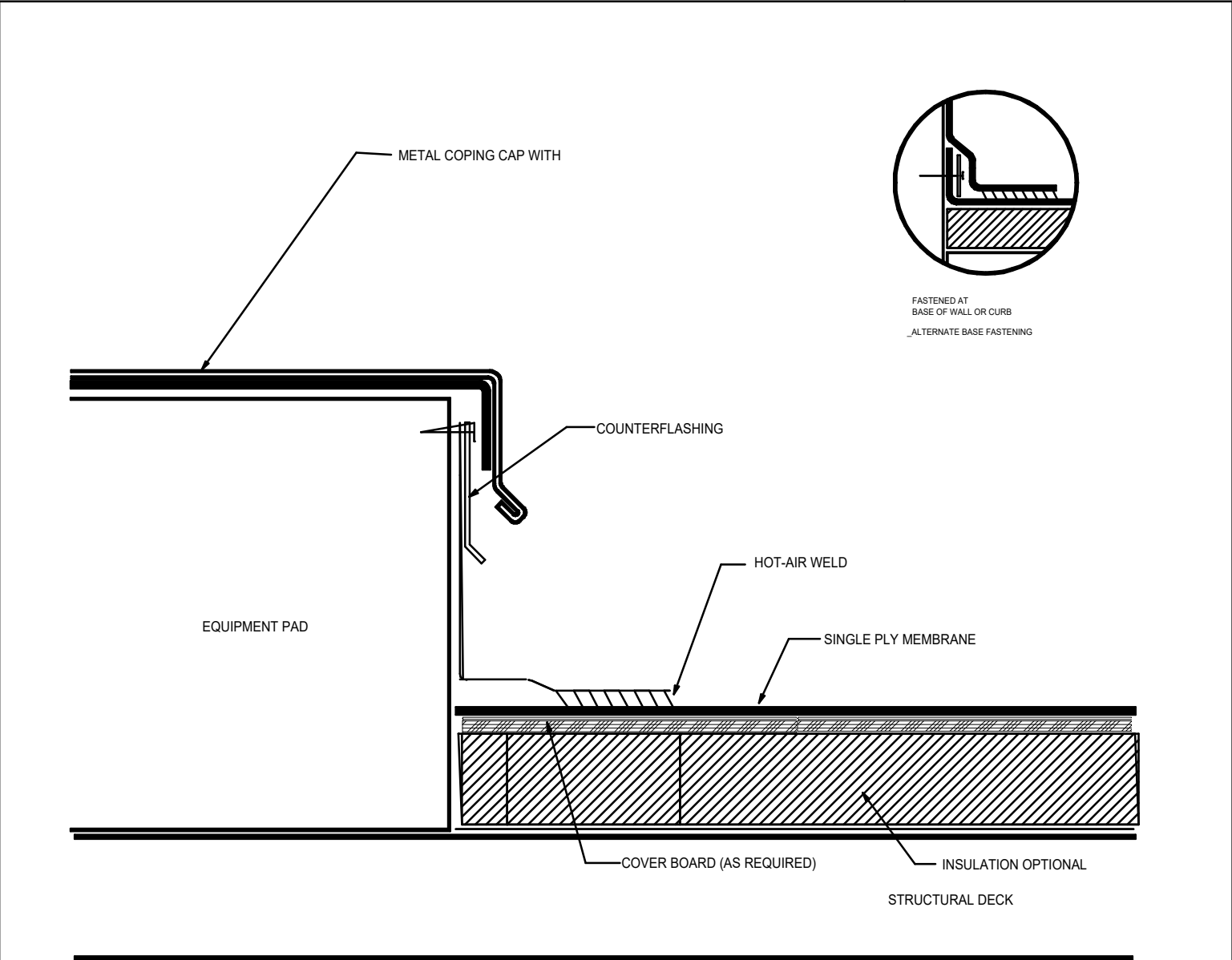

TYPICAL EQUIPMENT PAD DETAIL

DESERT WINDS HIGH SCHOOL

# NATIONAL ROOFING CONSULTANTS

CLIENT: AVHSD  
DATE: MAY 6, 2024

NAME OF BUILDINGS: DESERT WINDS HS BUILDINGS  
ADDRESS: 415 E. KETTERING ST., LANCASTER, CA 93035

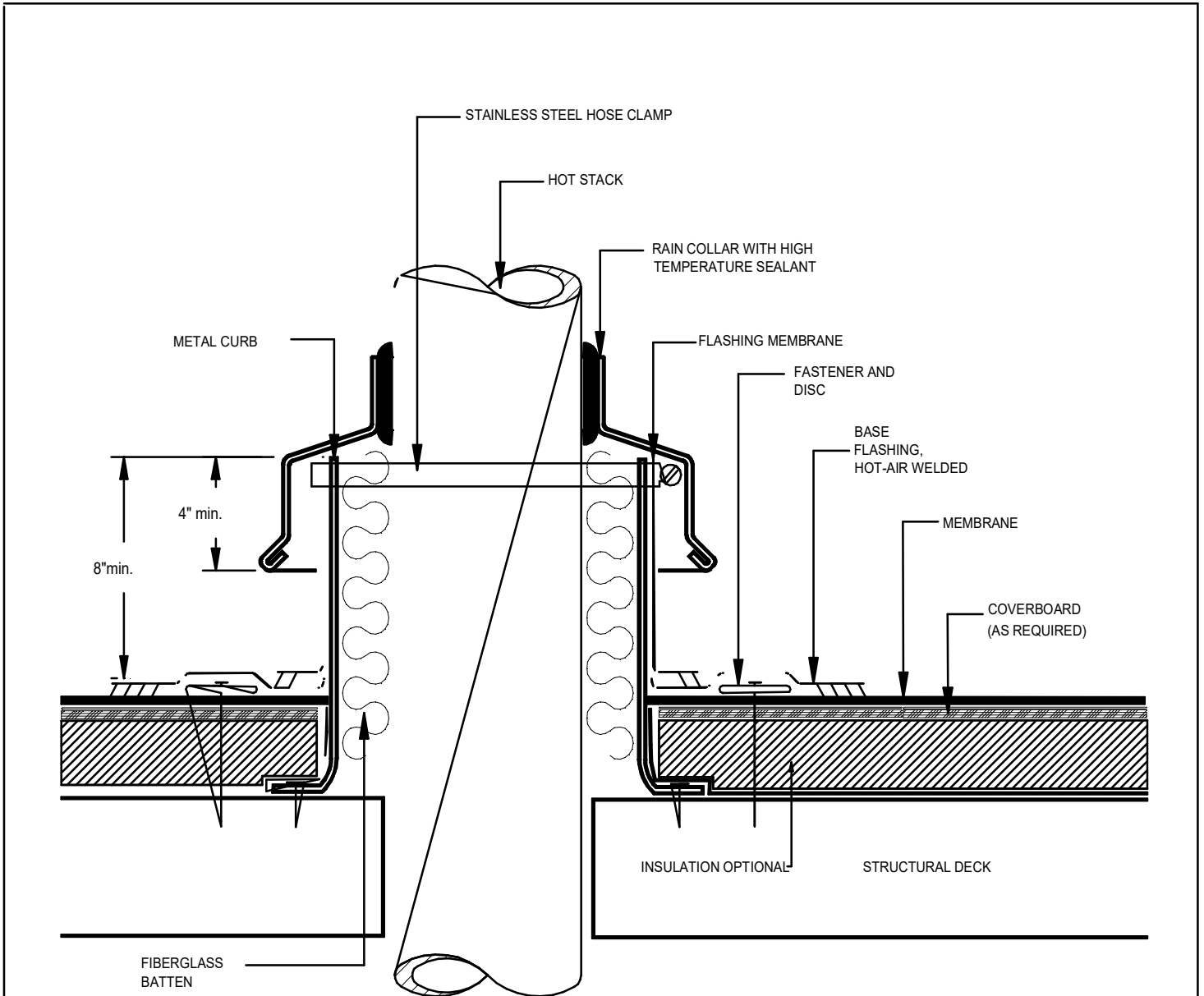

## HEATED STACK FLASHING

DESERT WINDS HIGH SCHOOL

# NATIONAL ROOFING CONSULTANTS

CLIENT: AVHSD  
DATE: MAY 6, 2024

NAME OF BUILDING: DESERT WINDS HIGH SCHOOL  
ADDRESS: 415 E. KETTERING ST, LANCASTER, CA 93535

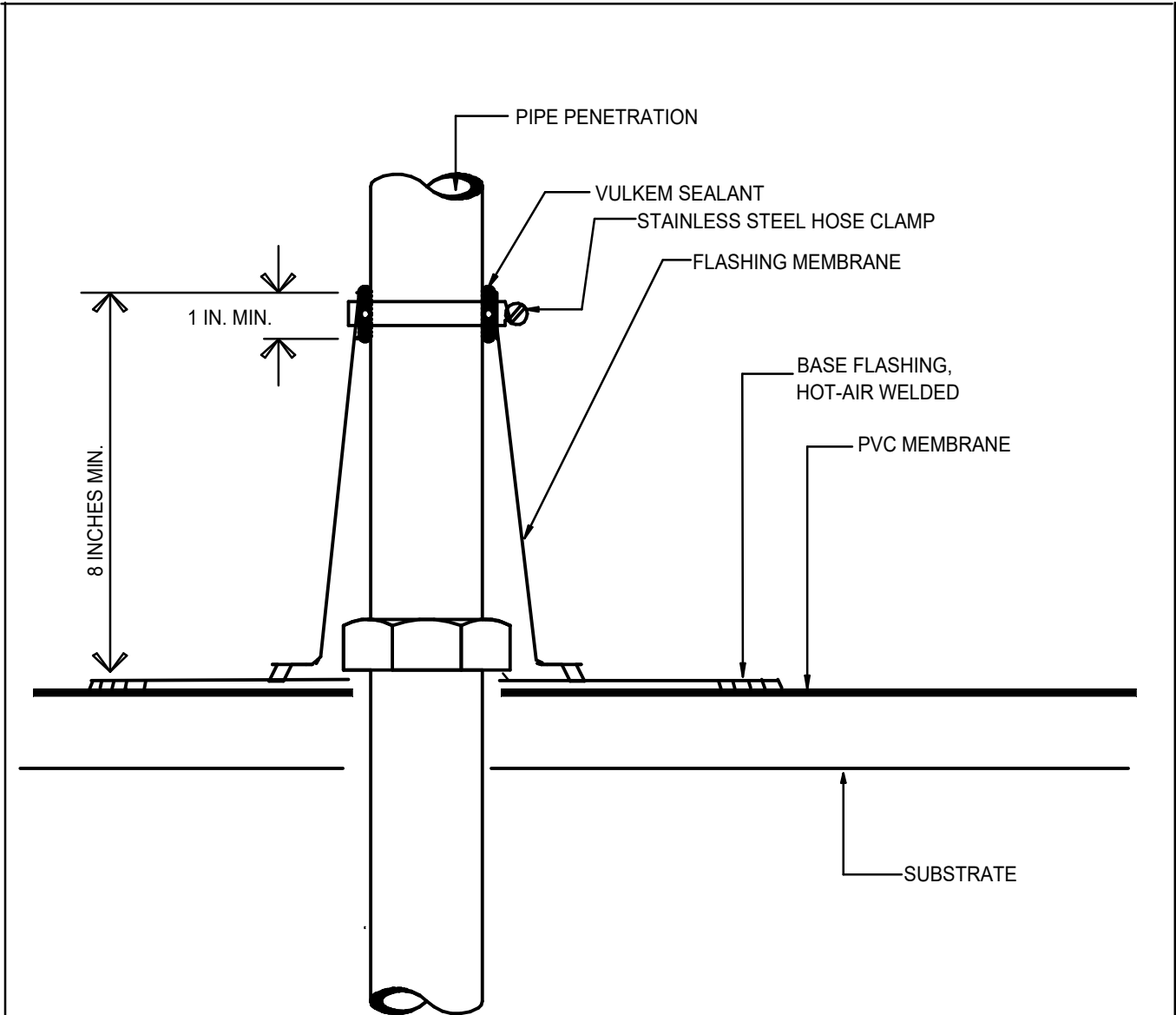

PIPE FLASHING DETAIL

DESERT WINDS HIGH SCHOOL

# ANTELOPE VALLEY UNION HIGH SCHOOL DISTRICT

**Eastside High School  
3200 East Avenue J-8  
Lancaster, CA 93535**

## **Section 07 56 00**

### **Silicone Roof Coating (ceramic granules)**

#### **PART I GENERAL**

##### 1.01 SCOPE

- A. All roofing areas, flashings, penetrations, drains, skylights, and equipment shall be included in the work under this section.
  
- B. Furnish materials and perform labor as specified and as necessary to complete the specified reroofing including, but not limited to, these major items:
  - 1. Pressure washing of roof surfaces.
  - 2. Evaluate condition of existing membrane system.
  - 3. Execute general maintenance and repairs.
  - 4. Application of white California Title 24 compliant/CCRC rated coating.
  - 5. Restoration of existing surface roof membrane using a high solid, silicone roof coating and polyester reinforcement.
  - 6. System provides a durable waterproof membrane over existing roof surfaces that have retained structural integrity but have become weathered and deteriorated.
  - 7. Include 20-year manufacturer NDL warranty.
  - 8. Building permit cost required as part of base bid; no exceptions.
  - 9. NOTE: Inspection services shall be utilized by the owner to oversee the work.

##### 1.02 REFERENCES

- A. American Society for Testing & Materials (ASTM)
- B. Federal Specifications (FS)
- C. Underwriters Laboratories (UL)
- D. Factory Mutual (FM)

##### 1.03 QUALITY ASSURANCE

- A. Compliance to Specifications
  - 1. Roofing foreman shall always have a copy of these specifications on the job during application and shall refer to same for proper application methods.
  - 2. Whenever specification items found herein are less stringent than the roofing manufacturer's published specifications, the manufacturer's minimum *requirements* shall be followed. Owner/owner representative will invite the roofing manufacturer's representative to the pre-construction conference, and the representative will visit the work in progress.
  - 3. Written specifications submitted to the roofing contractor do not relieve the roofing contractor of his obligation to thoroughly check the size, substrate, slope, and other conditions of the roof.

4. Contractor must provide submittals of alternate roofing materials including MSDS information five (5) days prior to pre-construction conference, for the purpose of review and approval by owner prior to the start of the work.

B. Regulatory Requirements

1. Fire Regulations: Roofing contractor shall be responsible for meeting fire regulations.
2. Safety barriers shall be erected around ladder and area around pipe or hose delivering coating to roof level. Warning tape shall be placed at material storage location and roof edges where roofing is in progress.
3. Barricades shall be placed around skylight openings during renovation of curbs. If skylights are not set, a temporary sheet of plywood shall be attached to close in the openings.
4. Roofing contractor shall be responsible to meet OSHA and Cal-OSHA requirements for safety of all involved and around buildings.
5. Roofing contractor shall obtain any required permits from the City of Lancaster as necessary

C. Quality Control

1. All work is to be performed under the full-time observation of National Roofing Consultants (NRC), 118 Lincoln Ave, Pomona CA 91767 909.620.0177.
2. Responsibility for Payment: Owner will provide and make payment to NRC for all daily observation; however, the roofing contractor will be responsible (by whatever arrangements are mutually agreed upon between the roofing contractor and the owner) for observation costs incurred as the result of unapproved time delays and observation costs incurred when work is not performed as scheduled.
3. Coordination
  - a. Job Conference: Prior to commencement of work the owner representative shall arrange a conference to be held at the job site to review specifications and to walk deck. Roofing contractor, owner representative, and NRC representative are to be in attendance.
  - b. Notification: The roofing contractor shall give 24 hours prior notice to consulting service before starting application and shall notify the same each time work is to be performed. Lack of notification of work schedule changes shall result in compensation for NRC's lost time and expenses.
  - c. Final/Punch List
    - (1) Consulting service shall be notified upon completion of roof and shall return and do final/punch list.

D. Change Orders

1. The Quality Control Observer does not have authority to permit specification changes. Any information or assistance provided by the same does not relieve the roofing contractor of strict compliance with specifications, drawings, and material manufacturer's requirements. NRC does not assume responsibility, such as water damage, which is normally the roofing contractor's. Bidders are required to meet the specifications at time of bid. The work will be observed according to the specifications.
2. No change orders covering cost additions to meet manufacturer's *requirements* will be accepted. The roofing contractor is responsible to meet all manufacturer's *requirements and job specifications*, whichever is more stringent. Costs to improve existing conditions, i.e. minimum curb height, lead drain flashings, crickets, etc. are to be included in the bid. Compliance with manufacturer *recommendations* shall apply only as directed by these specifications. The contractor shall identify those items that apply with the material manufacturer.



3. **Any variance from the specifications shall be by written change order or written instruction from owner/owner representative only. Work in question shall terminate until authorization to proceed has been given.**
  4. Bidder desiring to submit an alternate or equal material must do so five (5) days prior to bid due date. Failure to do so will disqualify bid. Include written proof in the form of ASTM and FS number, type, UL ratings and manufacturer's specification number.
- E. Roofing Contractor's Qualifications
1. Successful bidder must submit a letter from manufacturer stating that bidder is certified to install manufacturer's product.
- 1.04 SUBMITTALS
- A. Necessary items pertaining to Section 1.03A4.
  - B. Necessary items pertaining to Section 1.03D4.
  - C. Necessary items pertaining to Section 1.03E1.
- 1.05 DELIVERY, STORAGE AND HANDLING
- A. Delivery: Deliver all materials in their original containers with seals unbroken and manufacturer's label and product identification clearly legible on each package.
  - B. Storage: Store coatings and mastics at recommended temperatures appropriate for time of year materials are being installed. Do not allow water-based products to freeze. Product must be stored at 50° & 110°F Polyester must be kept dry.
- 1.06 PROJECT CONDITIONS
- A. Moisture: Wet materials shall not be applied nor shall roofing application proceed when moisture is on roof or deck. Temperature for application shall be between 40° F & 110° F.
  - B. Building Protection
    1. The building exterior must be protected from damage, markings, or spillage using tarpaulins or protective sheeting.
      - a. Interior walls must be protected as well from damage, markings, or spillage using tarpaulins or protective sheeting.
    2. The contractor will be responsible for damage to grass, shrubs, trees, or grounds including curbs and side walks. Protective covers shall be utilized under any equipment that would damage or stain any surface.
  - C. Clean Up: Premises shall be kept clean **daily** during application and left clean when roof is completed.
- 1.07 SEQUENCING AND SCHEDULING
- A. Roofing contractor shall inform owner representative and receive approval for start date, work duration time, material and equipment storage area and vehicle, equipment, and pedestrian traffic pattern.
- 1.08 GUARANTEE
- A. Roofing contractor shall provide to owner a written guarantee against defects of workmanship and to maintain roof in a watertight condition for a period of five (5) years from final acceptance of product by owner.
  - B. Roofer shall provide 20-year NDL manufacturer labor and material warranty.

**PART II PRODUCTS**

2.01 MATERIALS

- A. Roofing materials shall have a U/L Class A fire rating and shall be documented in the roofing manufacturer's current published specification. Submit manufacturer's printed specification for approval.
- B. Acceptable Manufacturers
1. APOC Roofing Systems; John Athanasion (562) 889-5565
  2. Tropical Roofing Products; Keith Colon (714) 559-9200
  3. Henry Products; Freddy Martinez (571) 538-0358
  4. Or NRC approved equal prior to bidding.
- C. Summary of Materials: Materials shall not be less than the following per 100 square feet.
- |     |  |                        |
|-----|--|------------------------|
| 1.  | Primer/base coat   | 3-4 gals per sq.       |
| 2.  | Polyester  | 1 ply                  |
| 3.  | Finish coat  | 2.5 gals per sq.       |
| 4.  | Granules   | 40 lbs. per sq. (min.) |
| 5.  | Polyester for flashing reinforcement   |                        |
| 6.  | Silicone patch for flashing and details  |                        |
| 7.  | Fleece top tape for flashing and details   |                        |
| 8.  | Silicone sealant   |                        |
| 9.  | Emulsion and chopped glass   |                        |
| 10. | White silicone roof coating applied at the total rate of 2.5 gallons per square in one coat. |                        |
|     | a. Weight  | 10.7 lbs./gallon       |
|     | b. Reflectivity  | .87                    |
|     | c. Solids by weight  | 96 + or - 2%           |
|     | d. Solids by volume  | 96 + or - 2%           |
|     | e. Elongation  | 210%                   |
|     | f. Tensile Strength  | 450 psi                |
|     | g. Permeability  | 5 perms                |
|     | h. Cure time   | 2-8 hours (approx)     |
|     | i. Application temperatures  | 40°F and rising        |
- D. Standards: All materials shall conform to the following:
1. Modified Plastic Roofing Cement: FS SS-C-153 Type I; ASTM D-4586 Type II or III; MUST NOT CONTAIN ASBESTOS.
  2. APOC Fleece-Top® Tape heavy-duty all-purpose tape & sealant.
  3. APOC 296 single ply adhesive primer
  4. Polyester Reinforced Fabric: Tensile Strength (ASTM D-5034) 35 lbs, Elongation (ASTM D-5034) 50%, Ball Burst (ASTM D-3787) 80 lbs, Trapezoid (ASTM D-1117) 14 lbs.
  5. Elastomeric Metal Primer: Water-based.
  6. White Acrylic Reflective Coating: Approved manufactures: APOC Roofing Products, or approved equal. Requirements: emissivity .75, reflectivity .70. CCRC rated. California Title 24 certified.
  7. Polyurethane Sealant: Sikaflex 1a moisture-cured, 1-component, polyurethane-based, non-sag elastomeric sealant, or equivalent.
  8. Pond Patch: Henry's Pond Patch trowel-applied leveling compound.
  9. Cap Sheet: 105 lbs., polyester, FR APP modified bitumen cap sheet, granule surfaced with factory-applied California; ASTM D 6222, U.L. Class A.
  10. Asphalt Primer: FS SS-A-701 or ASTM D-41 (dilute no more than 20% with paint thinner only).
  11. Flexible Flashings: Eternabond self-adhesive flashing by Eternabond Products.
  12. ChemCurb by Chemlink or equivalent.

13. Permaflash by J.M. or equivalent.

### **PART III EXECUTION**

#### **3.01 PREPARATION**

##### **A. Repairs/General Maintenance**

1. Surface shall be swept clean of all debris and power washed before making repairs. Surface must be completely dry before applying repair products or coatings.
2. For single ply membrane preparation, wash surface and install APOC 12" Fleece Top Incredible Tape over laps. After that, application of 296 Single Ply Adhesive Primer at ¼ to ½ gallon/100 square feet over entire surface.
3. Repair all splits and blisters in membrane. Embed two plies of APOC #483 polyester in an application of APOC #581 silicone patch (min. 1/8" thick layer per ply) or APOC #585 silicone coating at 3 gal/sq. Repair any wrinkles, folds, or fish mouths by embedding one ply of APOC #483 polyester in APOC #581 silicone patch or APOC #585 silicone coating at 3 gal/sq. and allow for a full cure.
4. Similarly, seal all splits, delaminated side laps, fish mouths, exposed ply reinforcements, protruding or exposed fasteners and like surface problems with manufacturer's required repair method.
5. Slice down and fully adhere loose and poorly applied cap sheet repairs around air conditioning units. Areas where tears or gaps exist should be patched with white mastic and polyester cloth.
6. Existing pipes and vents shall be cleaned and resealed with APOC #581 silicone patch using a wrap and target reinforcement of APOC #483 polyester or APOC Incredible Fleece Top tape.
7. Curbs, base flashing, and wall flashing up to 12" high: Including skylights, HVAC, fan, evaporator, equipment, and pipe support curbs. Embed APOC #483 polyester in an application of APOC #583 Armor Base or APOC #585 silicone and allow to completely cure. Polyester (min. 6" width) shall extend a minimum of 2" past the cant or corner without cant on the horizontal roof surface and continue a minimum of 1" past the top of the cant or corner. Brush in the polyester to assure no voids, wrinkles, or fish mouths.
8. Metal edge: Re-secure loose metal, clean and allow to completely dry. Apply six-inch-wide APOC Incredible Fleece Top tape and coat with APOC #583 Armor Base.
9. Scuppers: clean, let dry and embed 6" APOC #483 polyester reinforcement in APOC #581 silicone patch.
10. Josam Type Cast Iron Drains: Remove flashing ring, clean 4'x4' area and allow to completely dry. Apply and roll in a layer of APOC Incredible Fleece Top tape over the joint at the drain bowl. Extend tape a minimum of 1" on to the cast iron drain bowl and 3" on to the existing membrane. Embed a 2'x2' piece of APOC #483 Polyester Reinforcement in a layer of APOC #581 silicone patch and extend past drain ring down into the drain bowl. Apply a top layer of APOC #585 silicone roof coating over the polyester reinforcement and allow to fully cure overnight. Reinstall flashing ring. Work with owner's rep to arrange for water testing of drains and drainpipes.
11. Replace damaged drains and/or drain components.
12. Pitch pans: clean all exposed metal inside and out, fill and trowel to create a slight slope with APOC #581 silicone patch or APOC 5800 silicone sealant. New or replacement pitch pans may be filled with quick drying concrete grout to two inches from the top, then fill with APOC #581 silicone patch or APOC #5800 silicone sealant.
13. Wood blocking: remove and replace existing wood blocking with redwood or pressure treated 2x4 lumber for small pipes and 4x4 blocking for small HVAC units. Install blocks in APOC #581 silicone patch on top of ½" Dek-Top Walkway

Pads. Install new restoration membrane before installing roof walkway pads. For large horizontal gas lines and electrical conduit (2" diameter and larger), satellite dishes over 3' in diameter and HVAC units over 200 lbs. consult a structural engineer to design appropriate support system. Flash new steel supports with APOC #581 silicone patch and APOC #483 polyester reinforcement using a wrap and target method to assure a 5-course reinforcement at the base of the penetration.

B. Crickets

1. All curbs exceeding 30" facing up slope shall be outfitted crickets.
  - a. All crickets should extend to the corner of the curbs.
2. Apply pond patch, self-adhered modified bitumen, or granules thoroughly mixed with white mastic to mild ponding areas at existing crickets, or equivalent.
3. Crickets waterways: Build up small ponding areas along cricket waterways.
4. Valleys and Waterways: Embed one ply of APOC #482F polyester in a 3-4 gal/sq. application of APOC #583 Armor Base and allow to fully cure.
5. Metal counter flashing: Raise or remove existing metal counter flashing. Install specified base flashing. Reinstall metal so that base flashing is counter flashed. On masonry walls rake out the reglet joint and re-caulk with an APOC approved non staining sealant. On structural concrete, reseal between metal and concrete wall using an APOC approved sealant. On curbed HVAC units, reinstall metal counter flashing and seal between the unit and the counter flashing metal with a self-adhering, compressible foam tape.

C. Parapets

1. Scrape loose or flaking sealant and mastic off parapet keyways if applicable.
2. Apply white mastic, webbing, and white mastic in keyways in a 3-course fashion.

D. Ponding corrections

1. All roofs must maintain positive drainage. Ponding water is defined by the NRCA as "water that remains more than 48 hours after precipitation has stopped." Drainage can sometimes be improved by adding drains, changing the slope of the structural deck, or removing existing insulation and roof membrane and reinstalling a tapered insulation and new roof membrane.
2. Light ponding areas should receive an application of APP modified bitumen or Verticap material over an asphalt primed surface. Such applications should be washed as part of the power washing of the surface.
3. Light ponding areas may also receive a thoroughly mixed coating and granules.
4. Modified emulsion and granules followed by a 1 gal/sq top coating of modified emulsion with no granules topped with a broomed on 4' polyester cloth. This ponding repair should be coated with at least 1 gallon / sq of white elastomeric as a protection for the cloth scrim during the power wash phase and to prevent dust or debris contamination of the polyester scrim prior to coating the roof surface.
5. Replacement of heavily deflected sheets shall be included in the alternate. Remove heavily deflected sheets if other pond correction methods are insufficient. Replace deflected plywood and broken joists and tie in to the existing roofing with self-adhered applied modified bitumen prior to coating.

F. Asphalt spills and mastic repair areas

1. Excess asphalt spills and mastic repairs greater than 6" x 6" in size shall be covered with at least two (2) applications of modified emulsion till smoothed out and filled in. Once cured apply one (1) gal/sq modified emulsion and broom in 4' polyester fabric over the top cut to fit as needed. See process in 3.01F.

G. Cleaning

1. Remove soil, loose granules, grease, and debris.

2. Remove excess stucco and stucco spills from the base flashing areas.
3. Thoroughly wash entire cap sheet membrane under low pressure.
  - a. Remove contaminants using TSP or other non-sudsing cleaner.
  - b. Rinse off treated surfaces.

H. Allow surfaces to thoroughly dry.

### 3.02 DRAINS & SCUPPERS

#### A. Drains

1. Water test downspouts to assure unrestricted flow. Route clogged downspouts where needed. (Include HVAC dedicated condensate drain which appears to be clogged).
2. Remove and clean clamping ring on all drains and apply coating with polyester cloth extending 4' out from the drain in every direction and lap the inner drain bowl by 1". Then reinstall the clamp ring over the cured coating and polyester cloth membrane at the end of the job. All clamping ring bolts shall be fully engaged and tightened. Simply coating up to the drain will not be accepted nor will white mastic slathering of the drain to mask an incorrect application.

#### B. Scuppers

1. Upgrade sealant around scuppers and flash with polyester cloth and white mastic.
2. Extend sheet metal for all over flow scuppers that are short of the walls' exterior.
  - a. Clean, let dry and embed 6" polyester reinforcement in patch material.
  - b. Fully caulk the outer face of the scupper edges to prevent back flow.
  - c. Prime the scupper 4" inside the sleeve and any remaining exposed sheet metal outside the sleeve.
  - d. Apply white mastic and polyester cloth extending 4" into the sleeve and 6" outside of the sleeve to the inner face of the parapet wall at the scupper transition.

### 3.03 FLASHINGS

#### A. Pipes

1. Upgrade cracked mastic seals at necks and bases of pipes with white mastic and polyester cloth
2. Nested HVAC pipes where insulation is passing through the roof membrane shall be stripped approximately 2" off the deck to match the height of the Chem Curb or manufacturer's approved equivalent. Then apply Chem Curb or equivalent flashings.
3. Existing pitch pan type flashings shall be topped off with white mastic.
4. Low T-top flashings 6" or lower shall be removed; vent pipes extended to 10" off the deck, flashed with sheet metal flashings and integrated with torch-applied modified bitumen prior to coating.

### 3.04 PARAPETS

#### A. Counter Flashings

1. Cut out and replace deteriorated counter flashing sealant with specified sealant.

#### B. Keyways

1. Remove existing mastic at top of keyways.
2. Apply new white mastic, polyester reinforced fabric brushed to uncured base and allowed to cure then complete the third course as part of coating process

#### C. Base Flashings

1. Where base flashings with open laps or existing mastic require repairs, apply white mastic base with imbedded polyester cloth.

- D. Penetrations or exposed and protruding fasteners
  - 1. Knock down flush or replace all protruding fasteners along the parapet walls.
  - 2. Caulk all penetrations prior to coating or apply a glob of white mastic 1" beyond and over the nail heads.
  
- 3.05 EQUIPMENT
  - A. HVAC units.
    - 1. Repair flashings at HVAC curb corners with white mastic, polyester reinforced fabric brushed to uncured base and allowed to cure then complete the third course as part of coating process.
    - 2. Coat flexible flashing with specified coating.
    - 3. Roofing contractor responsible for all HVAC, electrical, etc. to be sealed/water tight and functioning properly.
  
  - B. FANS AND VENTS
    - 1. Repair flashings at curb corners with white mastic, polyester reinforced fabric brushed to uncured base and allowed to cure then complete the third course as part of coating process.
    - 2. Coat flexible flashing with specified coating.
    - 3. Secure all fans and vents where fasteners are absent or missing.
    - 4. Extend polyester fabric and coating up behind flashings under fans and vents where wood is exposed or visible from below the flashing.
  
- 3.06 MISCELLANEOUS
  - A. Debris: Clean roof of trash, soil, granules, and abandoned fixtures.
  
  - B. Sleepers: Sleepers for condensate lines shall be raised or removed during the coating process and replaced or reinstalled upon completion of the coating and included in the base bid. A slip sheet of granulated cap sheet or granulated APP modified will be installed under each condensate wood sleeper block.
    - 1. Deteriorated or missing wood sleepers shall be replaced with new red wood sleepers.
    - 2. Missing condensate attachment brackets for wood sleepers shall be installed as part of the base bid.
  
- 3.07 COATING
  - A. Coat with manufacturer's white coating (granules) to comply with Title 24 requirements.
  
  - B. Protection and start-up procedures:
    - 1. Prior to spray work, post notices around building and parking lots. Protect adjacent surfaces where product is not to be applied using masking tape, plastic, tarps or plywood, whichever is appropriate.
    - 2. Owner should be notified of start times, so that HVAC air intakes may be sealed off or shut down.
    - 3. Contractor must remove drain screens and temporarily seal drainpipes to prevent plugging during the coating operation. Unplug drains and reinstall screens after spray operation has been completed.
  
  - C. Base Coat: Apply APOC #583 Amor Base at the rate of 3-4 gallons per square and embed 1 ply of #482F polyester immediately. Side laps are minimum 4 inches and end laps are minimum 6". Broom in polyester to eliminate wrinkles and voids.
  
  - D. Finish Coat: After base coat has cured (a minimum of 48 hours) apply APOC #585 silicone roof coating at the rate of 2.5 gallons per square.

- E. Skim coat with granules: Wait a minimum of 4 hours depending on drying conditions and then apply a skim coat of APOC #585 high solids silicone roof coating at the rate of 1.0 gallons per square and broadcast APOC #11 ceramic granules at the minimum rate of 40 lbs. per square.
  - F. Note: NEVER apply to wet or damp or rusted surfaces. Surfaces should be completely cleaned before application. Low humidity may extend curing periods. All repairs must use compatible products.
- 3.08 JOB SITE CLEAN UP
- A. Remove masking and protection.
  - B. Notify owner application is complete so HVAC vents can be opened and units restarted.
  - C. Remove all roofing related trash and debris from jobsite.
  - D. Dispose of containers in accordance with local regulations.

**END OF SECTION 07 56 00**

May 7, 2024

Mr. Scott Fish  
Antelope Valley Union High School District  
44900 Division Street  
Lancaster, CA 93535

RE: 07 54 19 33 – Single Ply PVC Roofing  
R. Rex Parris High School

Dear Mr. Fish,

Enclosed please find the specifications you requested, based upon inspection of existing roofing and conditions at the referenced job site.

A 60-mil fully adhered PVC system has been specified on the low slope roof, which includes a 20-year no dollar limit (NDL) manufacturer warranty. The new PVC roof system shall meet title 24 and Class A requirements. Standard installation procedures have been outlined, as well as several customized instructions in these sections.

NRC can meet with selected contractors and manufacturer representatives in a Pre-Bid Walk to clarify the specifications and answer any questions. Subsequently, an addendum will be implemented. Please coordinate the job walk date with this office.

If you have any questions or need additional assistance, please call. Your use of our services is very much appreciated.

Sincerely,  
Edmund Hadvina  
Senior Consultant



# ANTELOPE VALLEY UNION HIGH SCHOOL DISTRICT

**R. Rex Parris High School  
38801 Clock Tower Plaza Drive E.  
Palmdale, CA 93550**

## **Section 07 54 19 33**

### **Single Ply PVC Roofing**

#### **PART I GENERAL**

##### **1.01 SCOPE**

- A. All roofing areas, flashings, penetrations, and equipment shall be included in the work under this section.
  
- B. Furnish materials and perform labor as specified and as necessary to complete the specified reroofing, including but not limited to these major items:
  - 1. Removal of and discarding existing built up roofing and aggregate down to the substrate.
  - 2. Low slope roof installation with white California Title 24, 60-mil single ply smooth PVC membrane adhered with low VOC adhesive over ½” Dens Deck Prime roof cover board.
  - 3. Include manufacturer 20-year NDL warranty.
  - 4. Preparation of deck substrate, which includes necessary repair.
  - 5. Installation of tapered insulation crickets as required correcting inadequate drainage.
  - 6. Installation of polyisocyanurate rigid insulation to match existing.
  - 7. Water testing of existing drains.
  - 8. Installation of new 24-gauge Kynar coated sheet coping metal at top of parapet walls. Alternate to save existing coping metal for reuse.
  - 9. NOTE: Inspection services shall be utilized by the Antelope Valley Union High School District (AVHSD) to oversee the work.
  - 10. NOTE: Tear off and disposal of asbestos-containing materials must be performed in accordance with governing codes and regulations.
  - 11. NOTE: The entire roof surface shall be washed after completion of installation.
  - 12. NOTE: Roofing contractor shall be responsible for necessary due diligence in terms of roof test cut samples and existing conditions to avoid unforeseen conditions and change orders.
  - 13. NOTE: Roofing contractor shall be responsible for damaged mechanical items, such as HVAC, ducting, exhaust fans during roof renovation and ensuring that all HVAC, electrical, etc. is water tight and functioning properly.
  - 14. NOTE: Roofing contractor shall be responsible for current governing codes, such as insulation, inspection, and permits.

##### **1.02 PERFORMANCE REQUIREMENTS**

- A. General: Provide and install specified membrane and its base flashings that remain watertight, do not pond water, resist thermal movement and resist exposure to weather without failure.

1.03 REFERENCES

- A. American Society for Testing & Materials (ASTM)
- B. Federal Specifications (FS)
- C. Underwriters Laboratories (UL)
- D. Factory Mutual (FM)

1.04 QUALITY ASSURANCE

A. Compliance to Specifications

- 1. Roofing foreman shall always have a copy of these specifications on the job during application and shall refer to same for proper application methods.
- 2. Whenever specification items found herein are less stringent than the roofing manufacturer's published specifications, the manufacturer's minimum *requirements* shall be followed. Antelope Valley Union High School District (AVHSD) will invite the roofing manufacturer's representative to the pre-construction conference, and the representative will visit the work in progress.
- 3. Written specifications submitted to the roofing contractor do not relieve the roofing contractor of his obligation to thoroughly check the size, substrate, slope, and other conditions of the roof.
- 4. Contractor must provide submittals of roofing materials including MSDS information at the pre-construction conference, for the purpose of review and approval by NRC prior to the start of the work.

B. Regulatory Requirements

- 1. Fire Regulations: Roofing contractor shall be responsible for meeting fire regulations. A certified fire extinguisher of adequate size shall be located on the roof near the work.
- 2. Roof Membrane Attachment: Membrane attachment shall conform to roofing manufacturer, Uniform Building Code, Factory Mutual and shall include upgrades to modify attachment for special requirements in area where building is located.
  - a. Minimum attachment shall conform to FM I-90.
- 3. Safety barriers shall be erected around chute to dumpster for demolition, and ladder to roof level. Warning tape shall be placed at material storage location and roof edges where roofing is in progress.
- 4. Roofing contractor shall be responsible to meet OSHA and Cal-OSHA requirements for safety of all involved and around buildings.
- 5. Hazardous materials shall be disposed of according to government regulations.
- 6. Roofing contractor shall obtain any required permits from the City of Palmdale as necessary.

C. Quality Control

- 1. All work is to be performed under the full-time observation of National Roofing Consultants (NRC), 118 Lincoln Ave, Pomona CA 91767 (909) 620-0177.
- 2. Responsibility for Payment: Antelope Valley Union High School District (AVHSD) will provide and make payment to NRC for all daily observation; however, the roofing contractor will be responsible by whatever arrangements are mutually agreed upon between the roofing contractor and the Antelope Valley Union High School District (AVHSD) for observation costs incurred as the result of unapproved time delays and observation costs incurred when work is not performed as scheduled.
- 3. As designated by the NRC representative, 1-1/2" sample welds shall be taken by roofing contractor each morning and afternoon prior to commencing application. Areas from which test cuts have been taken shall be repaired in manner directed by NRC representative and manufacturer representative as part of the work.

4. Coordination
  - a. Job Conference: Prior to commencement of work the Antelope Valley Union High School District (AVHSD) shall arrange a conference to be held at the job site to review specifications and to walk the deck. Roofing contractor, manufacturer representative, Antelope Valley Union High School District (AVHSD), and NRC representative are to be in attendance.
  - b. Notification: The roofing contractor shall give 72 hours prior notice to consulting service before starting application and shall notify the same each time work is to be performed. Lack of notification of work schedule changes shall result in compensation for NRC's lost time and expenses at the contractor's expense.
  - c. Final/Punch List
    - (1) Consulting service and the Antelope Valley Union High School District (AVHSD) shall be notified upon completion of roof and shall return and do final/punch list.

D. Change Orders

1. If a bidder sees work that bidder feels is part of the scope, but feels is not listed in specifications, bidder shall raise that question seven (7) days prior to bid opening. Antelope Valley Union High School District (AVHSD) will then clarify the scope or specification question at that time, or by addendum to the specifications. Attendance at the pre-bid conference is mandatory.
2. The Quality Control Observer does not have authority to permit specification changes. Any information or assistance provided by the same does not relieve the roofing contractor of strict compliance with specifications, drawings, and material manufacturer's requirements. NRC does not assume responsibility, such as water damage, which is normally the roofing contractors. Bidders are required to meet the specifications at time of bid. The work will be observed according to the specifications.
3. No change orders covering cost additions to meet manufacturer's *requirements* will be accepted. The roofing contractor is responsible to meet all manufacturers' *requirements*, which are more stringent than the issued job specifications. Costs to improve existing conditions, i.e. minimum curb height, lead drain flashings; crickets, etc. are to be included in the bid. Compliance with manufacturer *recommendations* shall apply only as directed by these specifications. The contractor shall identify those items that apply with the material manufacturer.
4. **Any variance from the specifications shall be by written change order or written instruction from Antelope Valley Union High School District (AVHSD) only. Work in question shall terminate until authorization to proceed has been given.**
5. Bidder wishing to submit an alternate or equal material must do so seven (7) days prior to bid due date. Failure to do so will disqualify bid. Include written proof in the form of ASTM and FS number, type, UL ratings and manufacturer's specification number.
6. When a make or trade name is specified, it shall indicate the standard required. Contractor proposing an alternate material shall submit the following:
  - a. Written application with explanation of why it should be considered.
  - b. Manufacturer's literature and samples of requested substitutions.
  - c. Three (3) job references of applications 5 years old or older available for inspection within 100 miles of project where substitutions were used under similar conditions.

E. Roofing Contractor's Qualifications

1. Bidder must include, with bid, a letter from manufacturer stating that bidder is certified to install manufacturer's product.

2. Job Experience: The roofing contractor installing the system shall have a minimum of two (2) years experience successfully applying the same or similar materials. The roofing contractor shall only use skilled workmen who are familiar with the products and application methods.
- F. Coordination
1. Contractor is required to attend a pre-construction conference with the consultant, Antelope Valley Union High School District (AVHSD) and material manufacturer representative, which will establish start date.
- 1.05 SUBMITTALS
- A. Necessary items pertaining to Section 1.04A4.
  - B. Necessary items pertaining to Section 1.04E1.
- 1.06 DELIVERY, STORAGE AND HANDLING
- A. Delivery: Deliver all materials in their original containers with seals unbroken and manufacturer label and product identification clearly legible on each package.
  - B. Storage: Store materials at site on pallets and under cover and maintain in dry condition.
- 1.07 PROJECT CONDITIONS
- A. Moisture: Wet materials shall not be applied nor shall roofing application proceed when moisture is on roof or deck.
  - B. Water tightness: Roofing contractor shall always be responsible for maintaining roof in a watertight condition. Interior damage caused by leakage during roof application shall be the responsibility of the roofing contractor.
  - C. Building Protection
    1. Tear-off and debris transit must not disturb operations of the building. Enclosed chutes and other methods shall be used to contain dust and debris.
    2. The building exterior must be protected from damage, markings, or spillage using tarpaulins or protective sheeting.
    3. The contractor will be responsible for damage to grass, shrubs, trees, or grounds including curbs and side walks. Protective covers shall be utilized under any equipment that would damage or stain any surface.
  - D. Clean Up: Premises shall be kept clean **daily** during application and left clean when roof is completed.
  - E. Contractor to provide portable toilet facilities.
  - F. Job Decorum: Dogs, drugs, alcohol, and radio playing are prohibited.
- 1.08 SEQUENCING AND SCHEDULING
- A. Roofing contractor shall inform Antelope Valley Union High School District (AVHSD) and receive approval for start date, work duration time, material and equipment storage area and vehicle, equipment, and pedestrian traffic pattern.
- 1.09 GUARANTEE
- A. Roofing contractor shall provide to Antelope Valley Union High School District (AVHSD) a written guarantee against defects of workmanship and to maintain roof in a watertight condition for a period of five (5) years from final acceptance of product by Antelope Valley Union High School District (AVHSD).

- B. Manufacturer's Warranty
  - 1. Provide manufacturer's 20-year NDL warranty to provide repairs or correction of roof stemming from material defects, contractor workmanship and ordinary wear and tear of elements.
  - 2. Warranty shall not exclude ponding water of any kind.

**PART II PRODUCTS**

2.01 MATERIALS

- A. Membrane
  - 1. The roofing system shall be adhered with a low VOC bonding adhesive for use with reinforced polyvinyl chloride (PVC) felt back membrane. PVC membrane shall be installed over 1/2" Dens deck prime roof cover board. Material components shall all be from one (1) manufacturer, shall have a U/L Class A fire rating, and shall be manufacturer's current published specification.
  - 2. Color
    - a. Low Slopes: White
    - b. Parapet Walls: White
- B. Approved Manufacturers and Products
  - 1. Manufacturers
    - a. Carlisle: FleeceBack PVC minimum thickness 60 mil  
Arturo Ortiz (818) 813-4082
    - b. Sika Sarnafil: S327 Feltback 60 mil  
Rob Stoeckinger (310) 883-4952
    - c. Soprema: Sentinel P150 HFB  
Missy McLain (805) 216 6630
    - d. IB Roof Systems: 60 mil PVC Feltback  
Jeremy Roberts (909) 273-4796
    - e. Or NRC approved equal
  - 2. Products
    - a. 60-mil minimum thickness PVC membrane
    - b. Low VOC bonding adhesive
    - c. 1/2" Dens Deck Prime roof cover board
    - d. Polyisocyanurate rigid insulation to match existing
    - e. NRC approved equal prior to bidding
- C. Summary of Materials: Materials shall not be less than the following per 100 square feet.

1.	1/2" Dens Deck Prime roof cover board	096.0 lbs
2.	Adhesive	011.0 lbs
3.	Single ply membrane	032.0 lbs
	<b>TOTAL APPROXIMATE WEIGHT</b>	<b>139.0 lbs</b>
- D. Standards: All materials shall conform to the following
  - 1. Low Slope PVC Felt Back Membrane: 60 mils (minimum) white, heat-welded polyvinyl chloride sheet roofing membrane.
  - 2. Polyisocyanurate rigid insulation to match existing
  - 3. Roof Cover board: 1/2" Dens Deck Prime roof cover board.
  - 4. Membrane Sealant: One-part polyurethane.
  - 5. Membrane Adhesive: Low VOC bonding adhesive.
  - 6. Termination Bar: 16-gauge extruded aluminum.
  - 7. Flashing Membrane: PVC membrane of specified thickness to be used for flashing.
  - 8. Miscellaneous Materials: Materials required or supplied by the manufacturer.
  - 9. Metal/Counter Flashing: 24-gauge Kynar coated sheet metal.

10. Tapered Insulation: Tapered perlite or polyisocyanurate, minimum ½" per foot or twice the roof slope, whichever is greater.
11. Coping Lap Sealant: Elastomeric silicone, one-part; Dow 795, GE Silpruf SCS 2000 or Sika WS-295
12. Penetration Seal: Prefabricated polymer curb with self-leveling, pourable sealant. Chem Curb by Chem Link, (800) 826-1681 or Carlisle specified pourable fluid-applied sealant for unusual penetrations.
13. Insulation and Underlayment Adhesive: Manufacturers recommended two-part low-rise foam adhesive.
14. Clad Metal Edge: 25-gauge, sheet metal edge with factory-applied PVC coating, 4" flange and face with 3" drip edge.

### **PART III EXECUTION**

#### **3.01 ASBESTOS REMOVAL**

- A. Removal and disposal of incidental asbestos-containing materials shall be performed in accordance with governing codes and regulations.

#### **3.02 PREPARATION OF SURFACES**

- A. Repair substrate as necessary.
- B. Assure substrate is smooth and clean.
- C. Provide water cutoffs or otherwise complete terminations and base flashings and seals to prevent water from entering completed work at the end of the day or when rain is eminent. Remove and discard temporary seals before beginning work on adjoining roofing.

#### **3.03 UNUSED JACKS, PIPES, PADS, ETC.**

- A. Remove from roof and level off. Fill large opening flush with deck level. Cover smaller holes with 24-gauge sheet metal, nailed solid. It is the roofing contractor's responsibility to identify all items to be removed before submitting bid.

#### **3.04 EXAMINATION**

- A. Verify that roof penetrations are in place and secured.
- B. Verify that wood blocking, curbs and nailers are securely anchored to the substrate.
- C. Verify that substrate is visibly dry and free of moisture.
- D. Verify that contaminants that will impair adhesion of roofing components have been removed.
- E. Proceed with installation only after unsatisfactory conditions have been corrected.

#### **3.05 OUTLETS**

- A. Drains
  1. Remove scupper flashings and replace with new 25-gauge, G-90 sheet metal with factory-applied PVC coating.
  2. Remove drain domes and clamping rings. Inspect for rust damage and replace any compromised domes that may not last 20 years.
  3. Prepare base per manufacturer's requirements, then apply roofing membrane. Install clamping ring and cover. NOTE: The roofing membrane shall smoothly transition with the drains and shall be applied in such a manner that water will not dam up.

### 3.06 FLASHINGS

- A. Pipe or Conduit Penetrations
  - 1. Remove and discard metal flashings and apply aluminum tape around penetrations if required or use cone or prefabricated boot. Seal tape with PVC flashing membrane and clamp off top with a hose clamp. Seal the clamp with specified sealant.
- B. Multiple (nested) Penetrations
  - 1. At multiple penetrations, provide manufacturer's one-part pourable sealant or install Chem Curb penetration seals installed per manufacturers' requirements.
- C. Sheet Metal Roof Vents
  - 1. Replace existing roof vents with new PVC clad metal vents having 6" wide flanges fabricated from clad metal. Secure vent flanges to with manufacturer's approved fasteners at 4" O.C. Heat weld field sheets to flange with 2" minimum wide weld.
  - 2. Install rodent screens at all openings larger than 3".

### 3.07 PARAPETS

- A. Walls
  - 1. Install roofing membrane fully adhered, and terminate at top outside edge or counter flashing, and securely attached with approved mechanical fasteners.
- B. Base Flashings
  - 1. Install (adhere) roofing membrane to the base of the wall, and then secure to deck with termination bar. Install flashing on wall just below the bottom of the upper reglet or curb counter flashing drip edge with proper adhesive. Secure top of flashing with termination bar. Seal top of termination bar and membrane termination point with specified sealant.
- C. Copings
  - 1. Install new metal copings after application of wall covering complete.
  - 2. Seal external coping laps with a 1/8" thick application of polyurethane sealant straddled across lap, neatly applied, and taped to avoid over application.

### 3.08 INSULATION AND COVER BOARD

- A. Insulation
  - 1. Install tapered insulation crickets at drain side walls. Contractor shall verify where crickets are required or where adverse conditions exist.
  - 2. Install Polyisocyanurate rigid insulation to match existing.
  - 3. Adhere all layers using manufacturers approved adhesive.
  - 4. Adhere 1/2" Dens Deck Prime roof cover board per manufacture's specifications.
  - 5. Do not install wet, damaged, or warped insulation boards.

### 3.09 ROOFING MEMBRANE

- A. The system is to be fully adhered. The smooth membrane is to be broomed and rolled immediately after placement to assure that adhesive has been properly spread (dispersed). Visual indications of adhesive beads (ribbons) or adhesive in general will not be accepted. Adjacent sheets of smooth membrane shall have minimum lap areas of 3" side and 6" end. When machine welding welds shall be 1-1/2", and 2" when hand welding. Welding equipment shall be provided by or approved by manufacturer. All completed welded seams shall be checked after cooling using a round screwdriver or another suitable blunt object. Visible evidence that welding is proceeding acceptably is smoke during the welding process, shiny membrane, and an uninterrupted flow of black material from the edge of completed joints.

3.10 SUPPORTS ON ROOF

- A. Replace existing wood pipe or equipment sleepers with new specified pre-manufactured supports. Leave supports standing freely on roof surface on buffer pads of membrane.

3.11 CLEAN-UP/TOUCH-UP/CLOSE-OUT

- A. Paint all new and existing metal (or use Kynar-coated metal), including new counterflashings with specified coating or paint in a minimum of two (2) coats. Color to be designated.
- B. Perform Antelope Valley Union High School District (AVHSD), NRC, and manufacturer final inspections.
- C. Provide manufacturer warranty documentation to Antelope Valley Union High School District (AVHSD).
- D. After final inspections, Antelope Valley Union High School District (AVHSD) shall determine an appropriate time for a complete pressure washing of the membrane. Washing shall be completed with the applicator present to repair any identified problems.
- E. Correct deficiencies or remove membrane that does not comply with manufacturer requirements. Membrane shall be free of damage or any condition that may prohibit or delay warranty implementation.
- F. Clean spillage or traffic marring using cleaning agents and procedures recommended by the manufacturer.
- G. Repair any gouges, scratches, cuts, open laps, etc. as marked by NRC on final inspection.

**END OF SECTION 07 54 19 33**



# NATIONAL ROOFING CONSULTANTS

CLIENT: AVHSD

NAME OF BUILDING:

R. REX PARRIS HIGH SCHOOL

DATE: MAY 6, 2024

ADDRESS: 38801 CLOCK TOWER PLAZA DR. E., LANCASTER, CA 93550

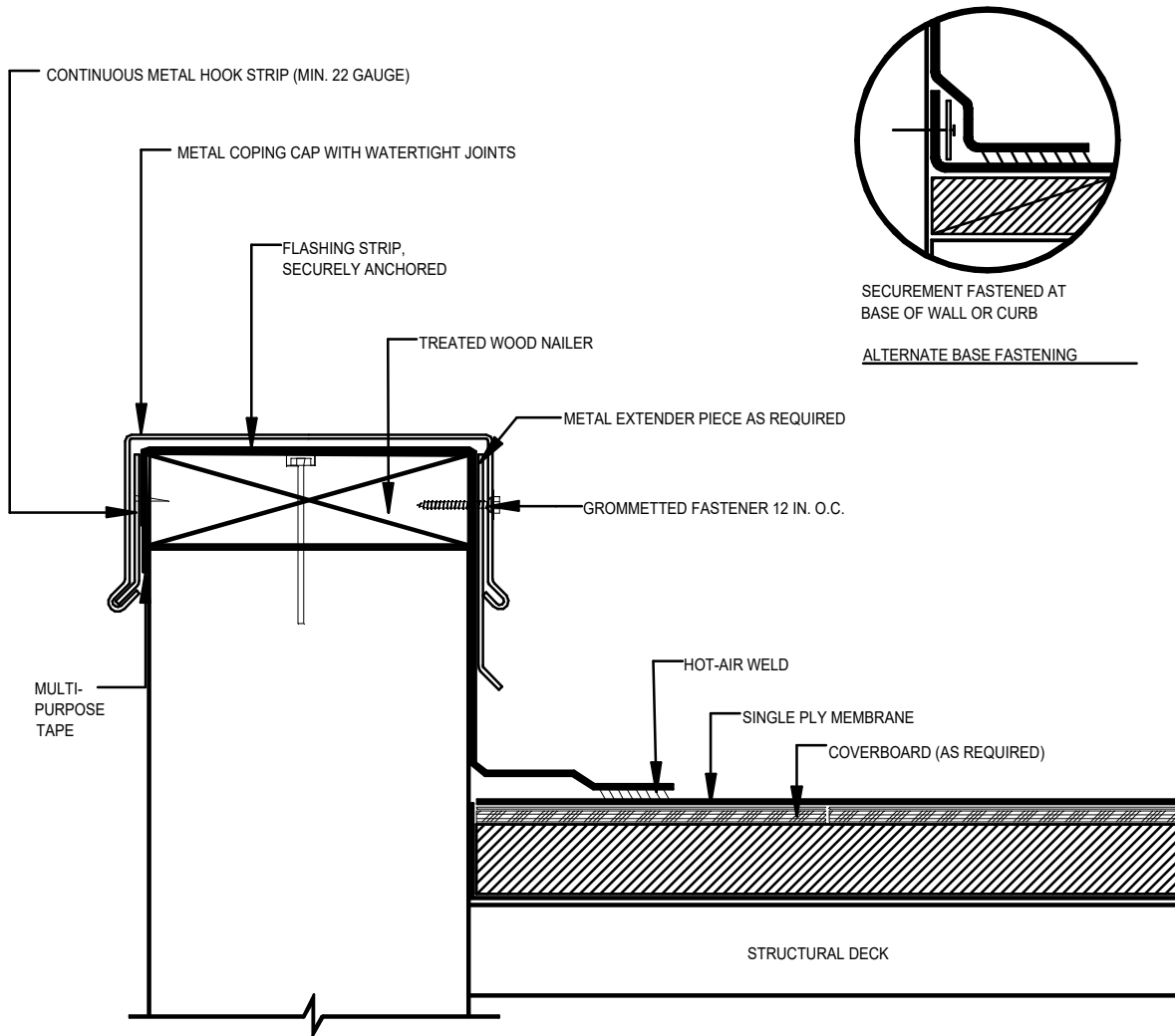

## PARAPET WALL WITH METAL COPING CAP

R. REX PARRIS HIGH SCHOOL

NATIONAL ROOFING CONSULTANTS

CLIENT: AVHSD

NAME OF BUILDINGS:

R. REX PARRIS HIGH SCHOOL

DATE: MAY 6, 2024

ADDRESS: 38801 CLOCK TOWER PLAZA DR. E., PALMDALE, CA 93550

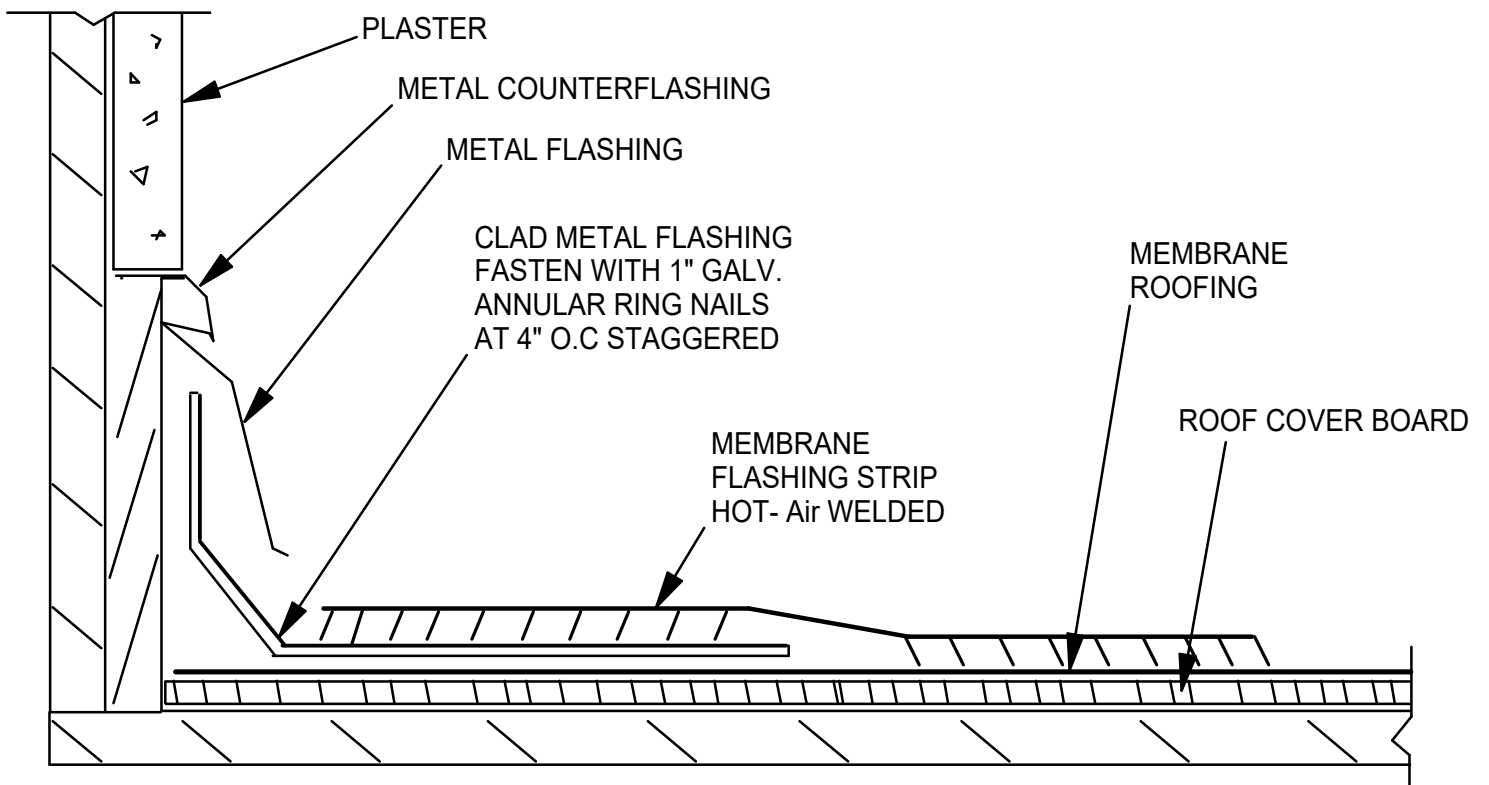

LOW FLASHING DETAIL

R. REX PARRIS HIGH SCHOOL

# NATIONAL ROOFING CONSULTANTS

CLIENT: AVHSD

NAME OF BUILDING:

R. REX PARRIS HIGH SCHOOL

DATE: MAY 6, 2024

ADDRESS: 38801 CLOCK TOWER PLAZA DR. E., PALMDALE, CA 93550

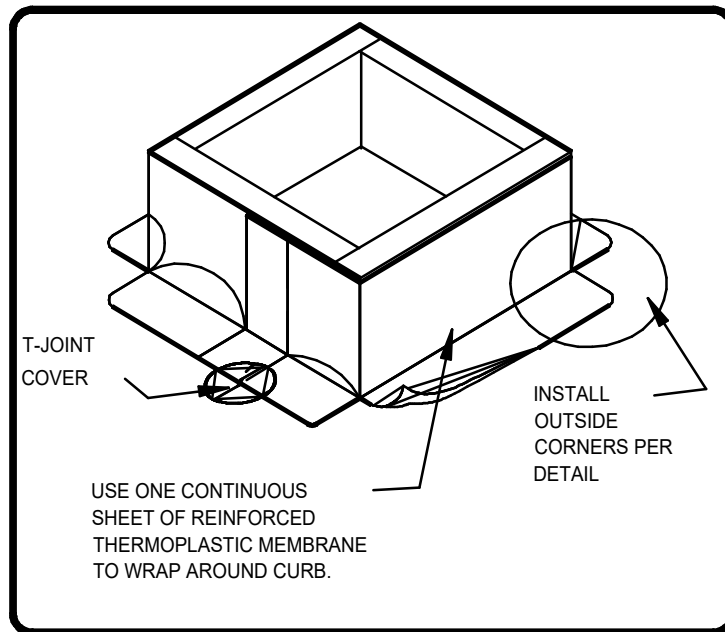
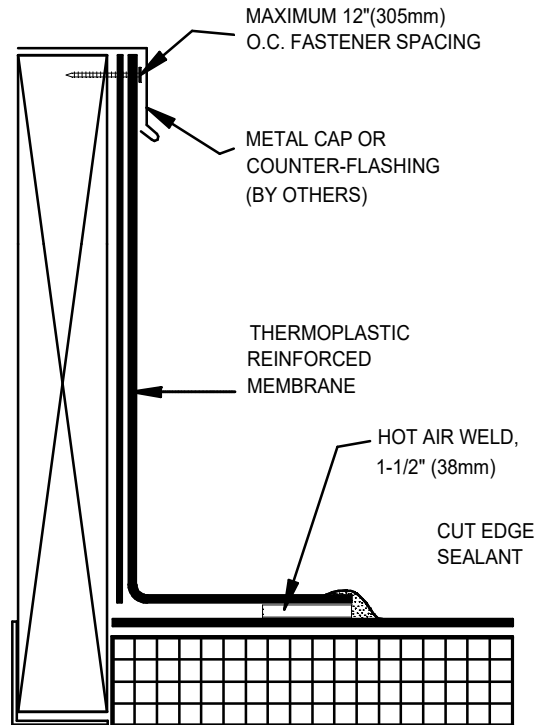

CURB FLASHING

R. REX PARRIS HIGH SCHOOL

# NATIONAL ROOFING CONSULTANTS

CLIENT: AVHSD  
DATE: MAY 6, 2024

NAME OF BUILDING: R. REX PARRIS HIGH SCHOOL  
ADDRESS: 38801 CLOCK TOWER PLAZA DR. E., PALMDALE, CA 93550

MEMBRANE SPLICE

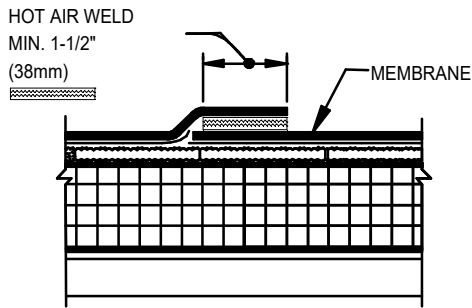

END LAP SPLICE

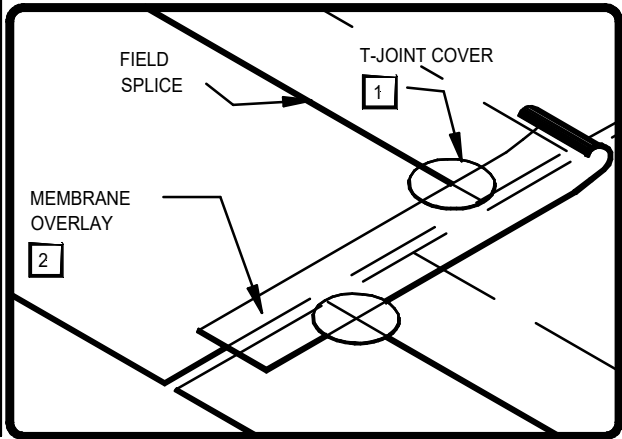
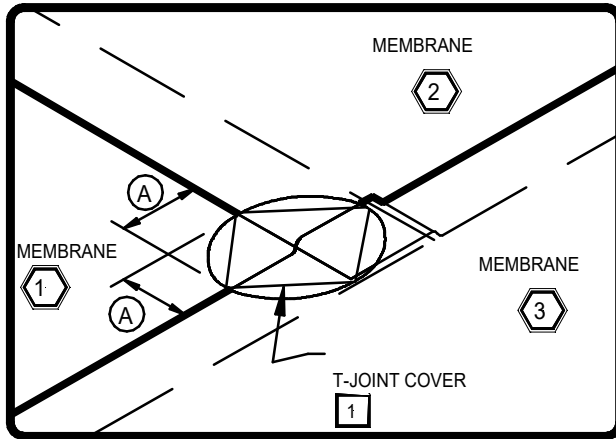
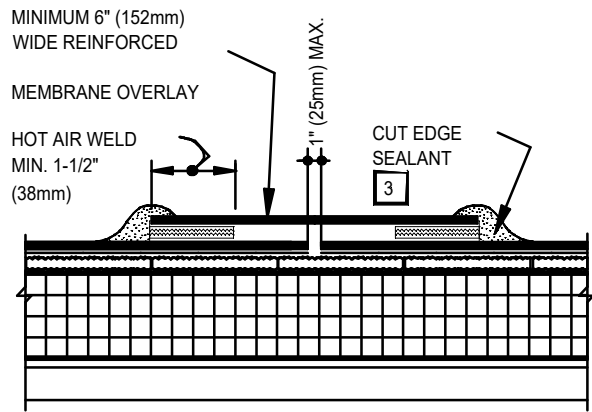

## MEMBRANE SPLICES

R. REX PARRIS HIGH SCHOOL

# NATIONAL ROOFING CONSULTANTS

CLIENT: AVHSD

NAME OF BUILDING:

R. REX PARRIS HIGH SCHOOL

DATE: MAY 6, 2024

ADDRESS: 38801 CLOCK TOWER PLAZA DR. E., PALMDALE, CA 93550

UP TO 20 YEARS

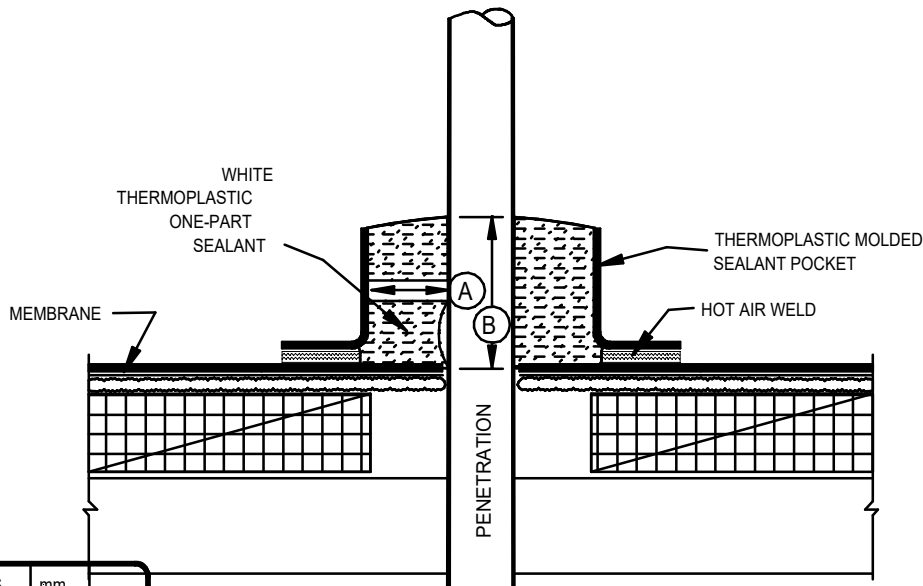

DIMENSIONS	mm	
(A)	1"	25 MIN.
(B)	2"	51 MIN.

NOTES:

- TEMPERATURE OF PIPE MUST NOT EXCEED 160° F (71°C).
- WHEN USING TPO MEMBRANE/MOLDED SEALANT POCKET, APPLY A THIN COAT OF TPO PRIMER TO THE INSIDE AND AROUND THE TOP RIM OF THE POCKET, TO THE DECK MEMBRANE ENCLOSED BY THE POCKET AND TO THE PENETRATION USING A SMALL PAINT BRUSH. WHEN USING PVC MOLDED SEALANT POCKET, CLEAN THE POCKET WITH PVC KEE HP CLEANER, APPLY TPO CLEANER TO PENETRATION(S) ONLY.
- ONE-PART SEALANT MUST COMPLETELY FILL MOLDED SEALANT POCKET TO PREVENT PONDING OF WATER.
- PIPE CLUSTERS MUST HAVE MINIMUM 1" (25mm) CLEARANCE BETWEEN PENETRATIONS.

PLACE MOLDED THERMOPLASTIC SEALANT POCKET AROUND PENETRATION AND OVERLAP THE TWO SECTIONS

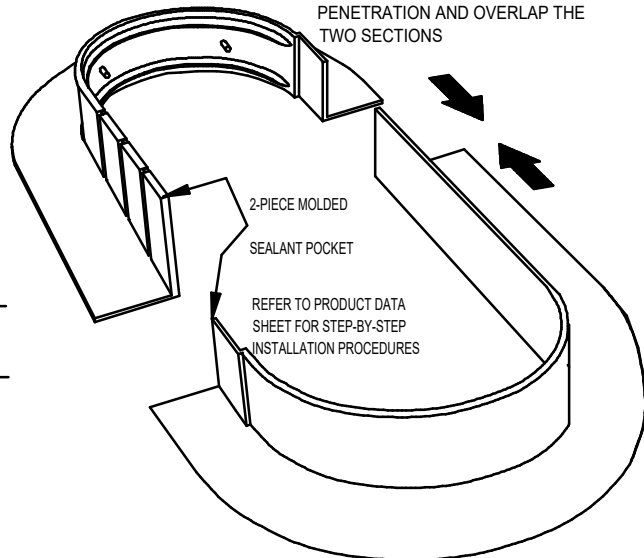

REFER TO PRODUCT DATA SHEET FOR STEP-BY-STEP INSTALLATION PROCEDURES

PENETRATION SEALANT POCKET

R. REX PARRIS HIGH SCHOOL

NATIONAL ROOFING CONSULTANTS

CLIENT: AVHSD

NAME OF BUILDING:

R. REX PARRIS HIGH SCHOOL

DATE: MAY 6, 2024

ADDRESS: 38801 CLOCK TOWER PLAZA DR. E., PALMDALE, CA 93550

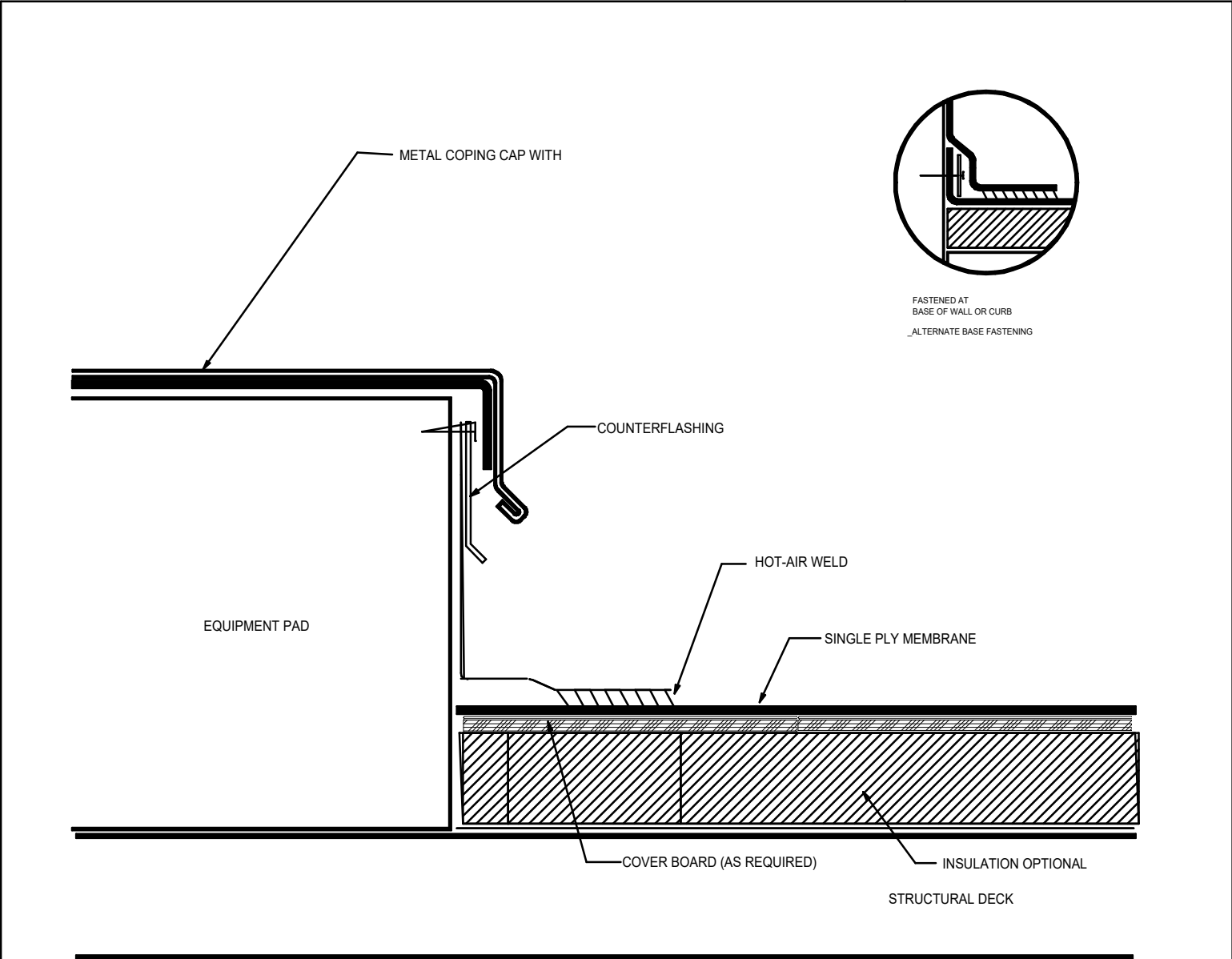

TYPICAL EQUIPMENT PAD DETAIL

R. REX PARRIS HIGH SCHOOL

# NATIONAL ROOFING CONSULTANTS

CLIENT: AVHSD  
DATE: MAY 6, 2024

NAME OF BUILDINGS: R. REX PARRIS HS BUILDINGS  
ADDRESS: 38801 CLOCK TOWER PLAZA DR. E., PALMDALE, CA 93550

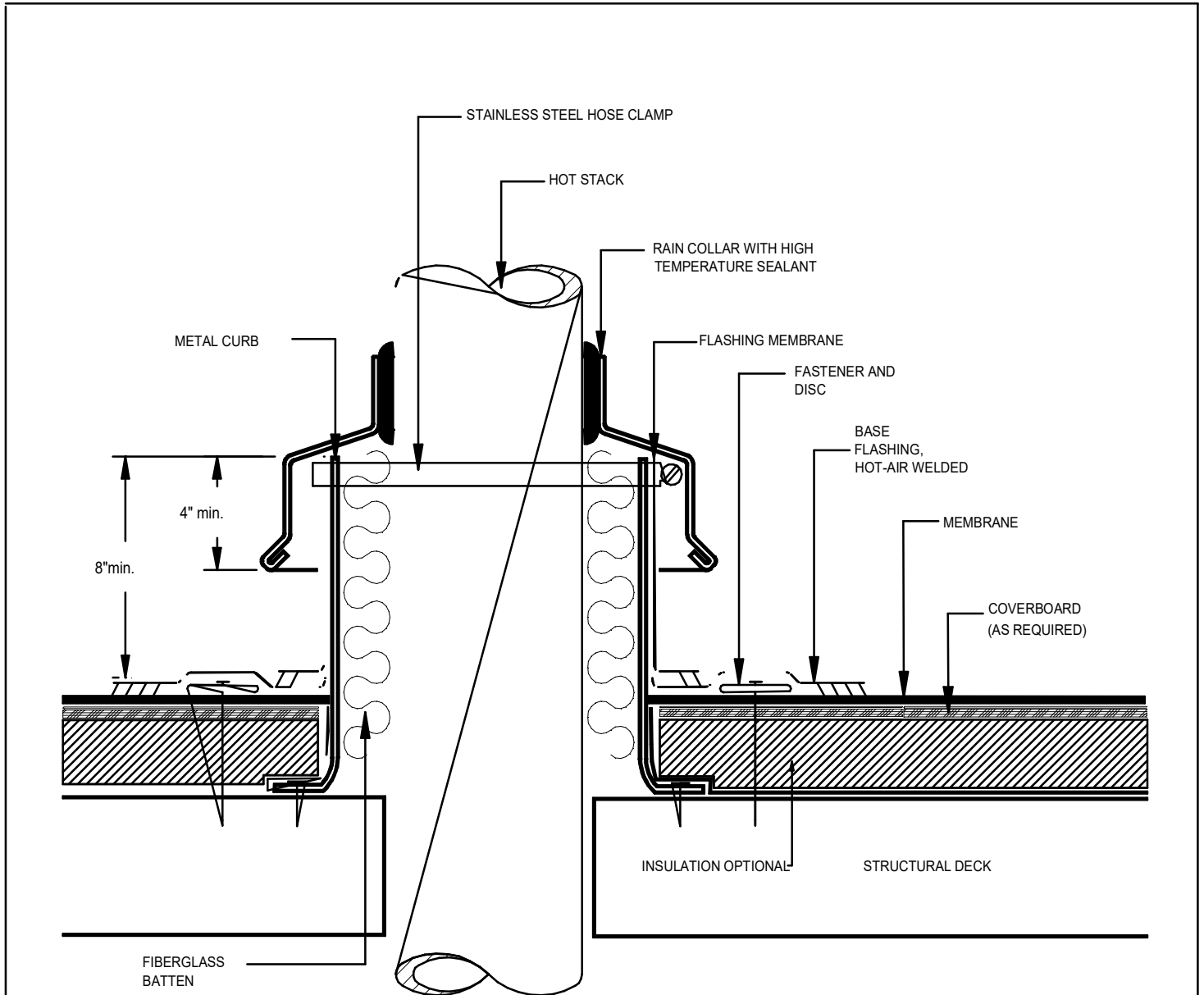

## HEATED STACK FLASHING

R. REX PARRIS HIGH SCHOOL

NATIONAL ROOFING CONSULTANTS

CLIENT: AVHSD  
DATE: MAY 6, 2024

NAME OF BUILDING: R. REX PARRIS HIGH SCHOOL  
ADDRESS: 38801 CLOCK TOWER PLAZA DR. E., PALMDALE, CA 93550

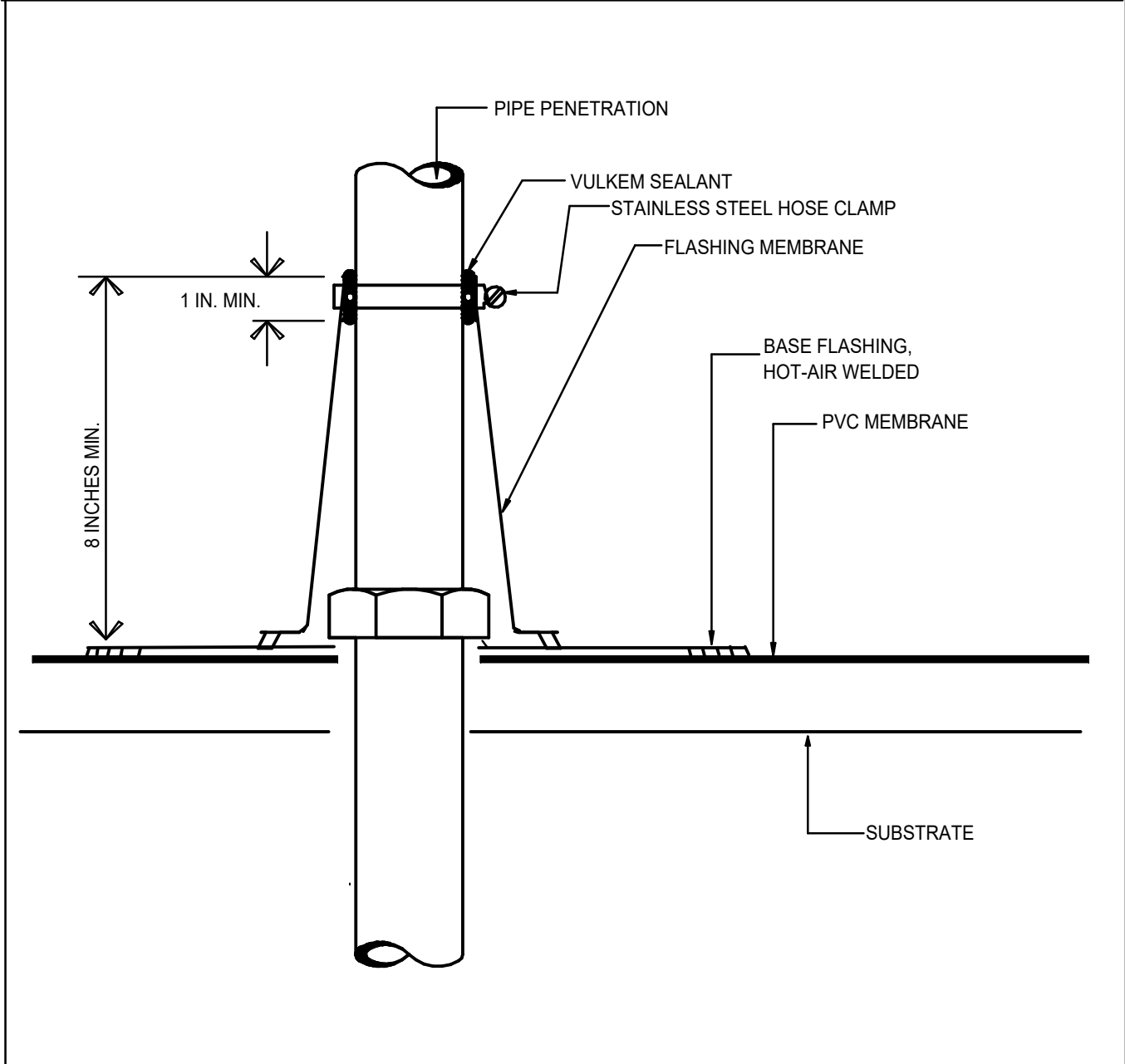

PIPE FLASHING DETAIL

R. REX PARRIS HIGH SCHOOL



# NATIONAL ROOFING CONSULTANTS

CLIENT: AVHSD  
DATE: MAY 6, 2024

NAME OF BUILDINGS: R. REX PARRIS HIGH SCHOOL  
ADDRESS: 38801 CLOCK TOWER PLAZA DR. E., PALMDALE, CA 93550

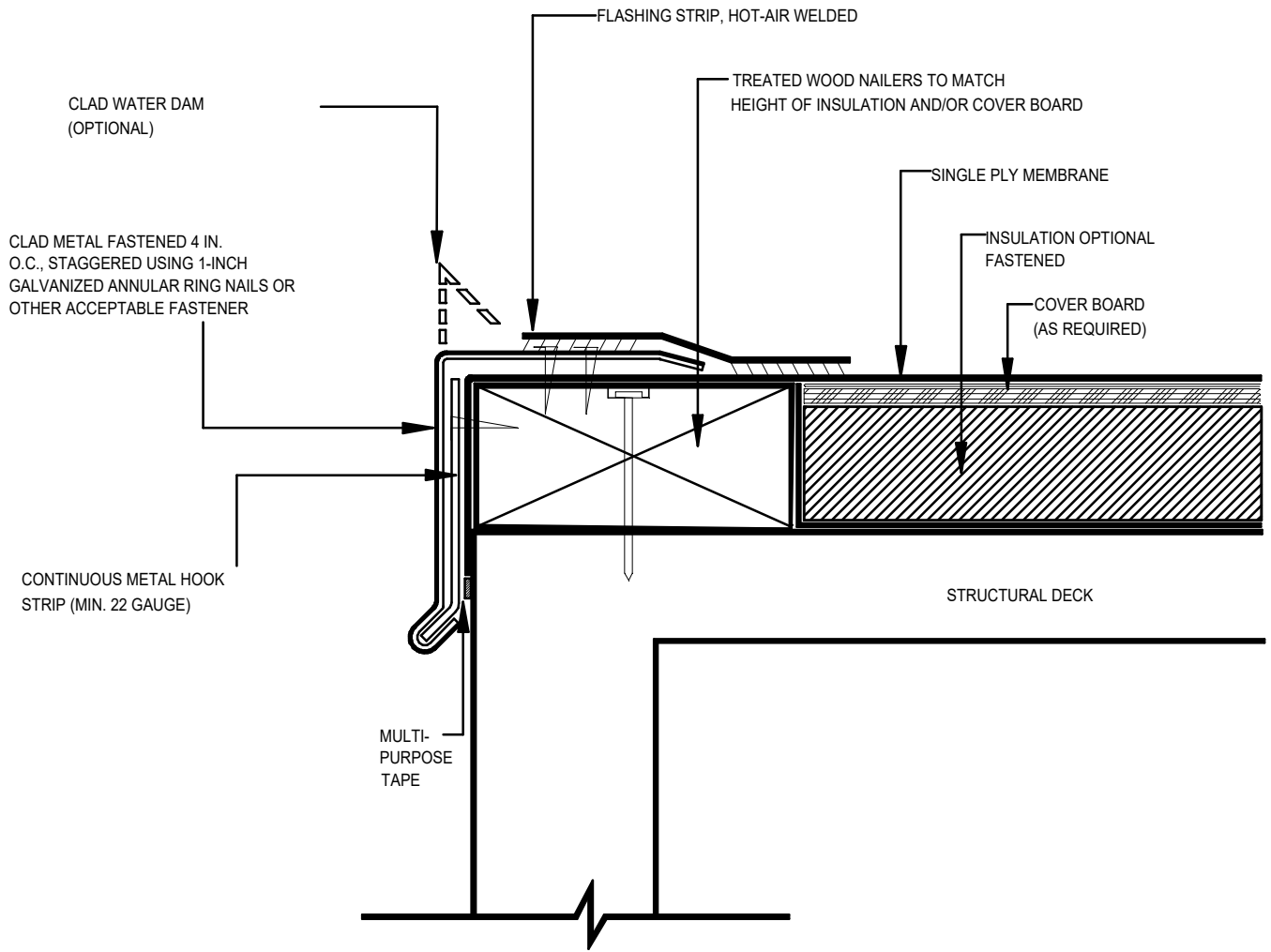

## METAL EDGE

R. REX PARRIS HIGH SCHOOL

COMMUNITY WORKFORCE AGREEMENT

BY AND BETWEEN THE

ANTELOPE VALLEY UNION HIGH SCHOOL DISTRICT

AND

LOS ANGELES AND ORANGE COUNTIES  
BUILDING AND CONSTRUCTION TRADES COUNCIL

AND

THE SIGNATORY CRAFT COUNCILS AND UNIONS

FOR

CONSTRUCTION, REPAIR, UPGRADE, RENOVATION,  
MODERNIZATION, EXPANSION, REHABILITATION AND IMPROVEMENT WORK

TABLE OF CONTENTS		Page
ARTICLE 1	INTENT AND PURPOSE	4
ARTICLE 2	SCOPE OF AGREEMENT	6
ARTICLE 3	UNION RECOGNITION AND EMPLOYMENT	10
ARTICLE 4	UNION ACCESS AND STEWARDS	15
ARTICLE 5	WAGES AND BENEFITS	16
ARTICLE 6	WORK STOPPAGES AND LOCKOUTS	17
ARTICLE 7	WORK ASSIGNMENTS AND JURISDICTIONAL DISPUTES	20
ARTICLE 8	MANAGEMENT RIGHTS	21
ARTICLE 9	SETTLEMENT OF GRIEVANCES AND DISPUTES	23
ARTICLE 10	REGULATORY COMPLIANCE	25
ARTICLE 11	SAFETY AND PROTECTION OF PERSON AND PROPERTY	26
ARTICLE 12	TRAVEL AND SUBSISTENCE	26
ARTICLE 13	APPRENTICES	26
ARTICLE 14	WORK OPPORTUNITIES PROGRAM	27
ARTICLE 15	WORKING CONDITIONS	28
ARTICLE 16	PRE-JOB CONFERENCES	29
ARTICLE 17	LABOR/MANAGEMENT COOPERATION	29
ARTICLE 18	SAVINGS AND SEPARABILITY	30
ARTICLE 19	WAIVER	30
ARTICLE 20	AMENDMENTS	31
ARTICLE 21	DURATION OF THE AGREEMENT	31
ATTACHMENT A	– LETTER OF ASSENT	34
ATTACHMENT B	– LOCAL RESIDENT ZIP CODES	35
ATTACHMENT C	– CRAFT EMPLOYEE REQUEST FORM	36
ATTACHMENT D	– DRUG AND ALCOHOL TESTING POLICY	38

**ANTELOPE VALLEY UNION HIGH SCHOOL DISTRICT  
COMMUNITY WORKFORCE AGREEMENT  
FOR CONSTRUCTION, REPAIR, UPGRADE, RENOVATION,  
MODERNIZATION, EXPANSION, REHABILITATION AND IMPROVEMENT WORK**

This Community Workforce Agreement (“Agreement”) is entered into by and among the Board of Education of the ANTELOPE VALLEY UNION HIGH SCHOOL DISTRICT (“District”), the Los Angeles/Orange Counties Building and Construction Trades Council (“Council”), and the signatory Craft Councils and Unions signing this Agreement (hereinafter together with the Council, collectively, the “Union” or “Unions”). This Agreement establishes the labor relations guidelines and procedures for the District and for the Contractors and craft employees represented by the Unions and engaged in Project Work. The District, Council and Unions are hereinafter referred to herein, as the context may require, as “Party” or “Parties.”

The Parties to this Agreement understand that if this Agreement is acceptable to the District, the policy of the District will be for Project Work to be contracted exclusively to Contractors who agree to execute and be bound by the terms of this Agreement, directly or through the Letter of Assent (a form of which is attached as “**Attachment A**”), and to require each of its subcontractors, of whatever tier, to become bound. The District shall include, directly or by incorporation by reference, the requirements of this Agreement in the advertisement of and/or specifications for each and every contract for Project Work to be awarded by the District.

The District shall actively administer and enforce the obligations of this Agreement to ensure that the benefits envisioned from it flow to all signatory Parties, the Contractors and crafts persons working under it, and the residents and students of the District. The District shall therefore designate a “Community Workforce Coordinator,” either from its own staff or an independent entity acting on behalf of the District, to monitor compliance with this Agreement; assist, as the authorized representative of the District, in developing and implementing the programs referenced herein, all of which are critical to fulfilling the intent and purposes of the Parties and this Agreement; and to otherwise implement and administer this Agreement.

The term “Apprentice” as used in this Agreement shall mean those employees registered and participating in Joint Labor/Management Apprenticeship Programs approved by the Division of Apprenticeship Standards, Department of Industrial Relations of the State of California.

The term “Contractor” or “Employer” as used in this Agreement includes any individual, firm, partnership, or corporation, or combination thereof, including joint ventures, which as an independent Contractor has entered into a contract with the District with respect to the Project Work, or with another Contractor as a subcontractor of whatever tier utilized by such Contractors for Project Work.

The term “Joint Labor/Management Apprenticeship Program” as used in this Agreement means a joint Union and Contractor administered apprenticeship program certified by the Division of Apprenticeship Standards, Department of Industrial Relations of the State of California.

The term “Letter of Assent” as used in this Agreement means the document that each Contractor (of any tier) must sign and submit to the Community Workforce Coordinator and the Council, before beginning any Project Work, which formally binds them to adhere to all the

forms, requirements and conditions of this Agreement, in the letter attached hereto as Attachment A.

The term “Project” or “Project Work” as used in this Agreement means the District’s Construction, Repair, Upgrade, Renovation, Modernization, Expansion, Rehabilitation and Improvement work and new construction projects which exceed the thresholds set forth in Section 2.2 of this Agreement and are contracted out by the District.

The term “Master Labor Agreements” as used in this Agreement, means the local collective bargaining agreements of the signatory Unions having jurisdiction over the Project Work and which have signed this Agreement.

The term “Subscription Agreement” means the contract between a Contractor and a Union’s Labor/Management Trust Fund(s) that allows the Contractor to make the appropriate fringe benefit contributions in accordance with the terms of MLA.

The Union and all Contractors agree to abide by the terms and conditions of this Agreement and agree that this Agreement represents the complete understanding of the Parties. No Contractor is or will be required to sign or otherwise become a party to any other collective bargaining agreement with a signatory Union as a condition of performing work within the scope of this Agreement, except as may be required under Section 2.7(b).

The Parties agree that this Agreement will be made available to, and will fully apply to, any successful bidder for Project Work, without regard to whether that successful bidder performs work at other sites on either a union or non-union basis. This Agreement shall not apply to any work of any Contractor other than that on Project Work specifically covered by this Agreement.

The use of masculine or feminine gender or titles in this Agreement should be construed as including both genders and not as gender limitations unless the Agreement clearly requires a different construction. Further, the use of Article titles and/or Section headings are for information only and carry no legal significance.

## **ARTICLE 1 INTENT AND PURPOSE**

Section 1.1 Background: The District's new construction and major rehabilitation projects will affect the school buildings and offices that are owned, leased or controlled by the District. The goal of this Project is to provide new construction and major rehabilitation of the District's facilities so as to provide sufficient facilities and technologies to educate properly the children within the District's boundaries. The District, therefore, wishing to utilize the most modern, efficient and effective procedures for construction, including assurances of a sufficient supply of skilled craftsperson's, and the elimination of disruptions or interference with Project Work, adopts this Agreement in the best interests of the students, parents, District staff, and the taxpayers of the District to meet the District’s goal that Project Work be completed on time and within budget.

Section 1.2 Identification and Retention of Skilled Labor and Employment of District Residents: The vast amount of new school construction, substantial rehabilitation, and capital improvement work scheduled to be performed by the District will require large numbers of craft personnel and other supporting workers. The parties understand and intend to use the opportunities provided by the extensive amount of work to be covered by this Agreement to identify and promote, through cooperative efforts, programs and procedures (which may include, for example, programs to prepare persons for entrance into formal apprenticeship programs, or outreach programs to the community describing opportunities available as a result of the Project), the interest and involvement of District residents in the construction industry; assist them in entering the construction trades, and through utilization of the joint labor/management sponsored apprenticeship programs, provide training opportunities for those District residents and other individuals wishing to pursue a career in construction. Further, with assistance of the Community Workforce Coordinator, the District, the contractors, the Unions and their affiliated regional and national organizations, will work jointly to develop and implement procedures promptly for the identification of craft needs, the scheduling of work to facilitate the utilization of available craft workers, and to secure the services of craft workers in sufficient numbers to meet the high demands of the Project Work to be undertaken.

Section 1.3 Encouragement of Local and Small Business: The Project will provide many opportunities for local and small business enterprises to participate as contractors or suppliers, and the parties therefore agree that they will cooperate with all efforts of the District, the Community Workforce Coordinator, and other organizations retained by the District for the purpose of encouraging and assisting the participation of local and small businesses in Project Work. Specifically, all parties understand that the District has established and quantified goals which place a strong emphasis on the utilization of local and small businesses on the Project. Each party agrees that it shall employ demonstrable efforts to encourage utilization in an effort to achieve such goals. This may include, for example, participation in outreach programs, education and assistance to businesses not familiar with working on a project of this scope, and the encouragement of local residents to participate in Project Work through programs and procedures jointly developed to prepare and encourage such local residents for apprenticeship programs and formal employment on the Project through the referral programs sponsored and/or supported by the parties to this Agreement. Further, the parties shall ensure that the provisions of this Agreement do not inadvertently establish impediments to the participation of local and small businesses, and residents of the District.

Section 1.4 Project Cooperation: The parties recognize that the construction to take place under this Agreement involves unique and special circumstances which dictate the need for the parties to develop specific procedures to promote high quality, rapid and uninterrupted construction methods and practices. The smooth operation and successful and timely completion of the work is vitally important to the parents and the students of the District. The parties therefore agree that maximum cooperation among all parties involved is required; and that with construction work of this magnitude, with multiple contractors and crafts performing work on multiple sites of over an extended period of time, all parties agree to work in a spirit of harmony and cooperation, and with an overriding commitment to maintain the continuity of Project Work. Further, the parties recognize that an Act of God or on Act of War could require the District to partially or fully suspend Project Work. The parties shall fully cooperate with any request by the District to redirect their equipment, skills and expertise to support the District's efforts necessitated by such events.

Section 1.5 Workers' Compensation Carve-out: Further, the parties recognize the potential which the Project may provide for the implementation of a cost-effective workers' compensation system as permitted by California Labor Code, Section 3201.5, as revised. Should the District request, the Union parties agree to meet and negotiate in good faith with representatives of the District for the development, and subsequent implementation, of an effective program involving improved and revised dispute resolution and medical care procedures for the delivery of workers' compensation benefits and medical coverage as permitted by the Code.

Section 1.6 Peaceful Resolution of All Disputes: In recognition of the special needs of the Project and to maintain a spirit of harmony, labor-management peace and stability during the term of this Community Workforce Agreement, the parties agree to establish effective and binding methods for the settlement of all misunderstandings, disputes and grievances; and in recognition of such methods and procedures, the unions agree not to engage in any strike, slowdowns or interruptions or disruption of Project Work, and the contractors agree not to engage in any lockout, or any other action impairing or impeding the Project Work.

Section 1.7 Binding Agreement on Parties and Inclusion of District Residents and Businesses: By executing this Agreement, the District, Council, Unions and Contractors agree to be bound by each and all of the provisions of this Agreement, and pledge that they will work together to adopt, develop and implement processes and procedures which are inclusive of the residents and businesses of the District.

## **ARTICLE 2 SCOPE OF AGREEMENT**

Section 2.1 General: This Agreement shall only apply to work which is contracted out by the District. This Agreement shall apply and is limited to all of the District's Project Work, as specified in Section 2.2 of this Article, performed by those Contractor(s) of whatever tier that have contracts awarded for such work, for the development of the District's facilities which, jointly, constitute the Project, and have been designated by the District for construction or rehabilitation.

Section 2.2 Specific: The Project is defined and limited to:

2.2.1 All Project work pursuant to prime multi-trade construction contracts that exceed two hundred fifty thousand dollars (\$ 250,000.00) and all subcontracts flowing from these prime multi-trade contracts; and

2.2.2 All prime specialty contracts for Project Work that exceed one-hundred thousand (\$100,000), and all subcontracts flowing from these specialty contracts.

2.2.3 The Parties understand that the District may at any time, and at its sole discretion, determine to build segments of the Project under this Agreement which were not currently proposed, or to modify or not to build any one or more particular segments proposed to be covered and that the District may at any time, and at its sole discretion, add additional projects under this Agreement not otherwise covered by this Agreement.



2.2.4 All Workforce Housing awarded by and performed on behalf of the District, pursuant to prime multi-trade construction contracts that exceed two hundred fifty thousand dollars (\$ 250,000.00) and all subcontracts flowing from these prime multi-trade contracts, as well as all prime specialty contracts that exceed fifty thousand (\$50,000), and all subcontracts flowing from these specialty contracts, shall be considered as Project Work under this Agreement.

Section 2.3 Bundling of Contracts: The Parties understand that, to the maximum extent feasible, and consistent with goals of the District to (i) utilize this Agreement as the Labor Relations Policy for its construction and rehabilitation program, and (ii) fully utilize the services of small and local business enterprises for such construction and rehabilitation work:

2.3.1 The District, in its sole discretion, will seek to group (or “bundle”) for bidding, contracts not meeting the thresholds of Section 2.2.1 or 2.2.2 above. (Small contracts for like types of work, scheduled to be undertaken at the same school, in the same District or on the same project site, and within the same timeframe, will be considered for such bundling, consistent with economies of scale, and the purposes of this Agreement); and

2.3.2 Project Work will not be split, divided or otherwise separated for contract award purposes to avoid application of this Agreement.

Section 2.4 Exclusions: Items specifically excluded from the Scope of this Agreement include the following:

2.4.1 Work of non-manual employees, including but not limited to: superintendents; administrators; teachers; supervisors; timekeepers, mail carriers, clerks, office workers, messengers; guards, safety personnel, emergency medical and first aid technicians; and other professional, engineering, administrative, supervisory and management employees;

2.4.2 Equipment and machinery owned or controlled and operated by the District;

2.4.3 All off-site manufacture and handling of materials, equipment or machinery; provided, however, that lay down or storage areas for equipment or material and manufacturing (prefabrication) sites, dedicated solely to the Project or Project Work, and the movement of materials or goods between locations on a Project site are within the scope of this Agreement;

2.4.4 All employees of the District, Community Workforce Coordinator, design teams (including, but not limited to architects engineers and master planners), or any other consultants for the District (including, but not limited to, project managers and construction managers and their employees not engaged in Project Work) and their sub-consultants, and other employees of professional service organizations, not performing manual labor within the scope of this Agreement; provided, however, that it is understood and agreed that Surveyors and Building/Construction Inspector and Field Soils and Materials Testers (Inspectors) are a covered craft under the CWA. This inclusion applies to the scope of work defined in the State of California Wage Determination for said Crafts. This shall also specifically include such work where it is referred to by utilization of such terms as "quality control" or "quality assurance." Every Surveyor and Inspector, performing under the Wage classification of Building/Construction Inspector and Field Soils and Material Testers, under a professional



services agreement of a construction contract shall be bound to all applicable requirements of the CWA. Project Work as defined by this Agreement shall be performed pursuant to the terms and conditions of this Agreement regardless of the manner in which the work was awarded;

2.4.5 Any work performed on or near or leading to or into a site of work covered by this Agreement and undertaken by state, county, city or other governmental bodies, or their Contractors; or by public utilities, or their Contractors; and/or by the District or its Contractors (for work for which is not within the scope of this Agreement);

2.4.6 Off-site maintenance of leased equipment and on-site supervision of such work;

2.4.7 It is recognized that certain materials, equipment and systems of a highly technical and specialized nature will have to be installed at the Project. The nature of the materials, equipment and systems, together with requirements of manufacturer's or vendor's warranty, may dictate that it be prefabricated, pre-piped, and/or pre-wired and that it be installed under the supervision and direction of Owner's and/or manufacturer's personnel. The Unions agree to install such material, equipment and systems without incident;

2.4.8 Non-construction support services contracted by the District, Community Workforce Coordinator, or Contractor in connection with this Project;

2.4.9 Off-site laboratory work for testing.

## Section 2.5 Awarding of Contracts:

2.5.1 The District and/or the Contractors, as appropriate, have the absolute right to award contracts or subcontracts on this Project to any Contractor notwithstanding the existence or non-existence of any agreements between such Contractor and any Union parties, provided only that such Contractor is ready, willing and able to execute and comply with this Community Workforce Agreement should such Contractor be awarded work covered by this Agreement.

2.5.2 It is agreed that all Contractors and subcontractors of whatever tier, who have been awarded contracts for work covered by this Agreement, shall be required to accept and be bound to the terms and conditions of this Community Workforce Agreement, and shall evidence their acceptance by the execution of the Letter of Assent set forth in **Attachment "A"** hereto, prior to the commencement of work. At the time that any Contractor enters into a subcontract with any subcontractor of any tier providing for the performance on the construction contract, the Contractor shall provide a copy of this Agreement to said subcontractor and shall require the subcontractor, as a part of accepting the award of a construction subcontract, to agree in writing in the form of a Letter of Assent to be bound by each and every provision of this Agreement prior to the commencement of work on the Project. No Contractor or subcontractor shall commence Project Work without having first provided a copy of the Letter of Assent as executed by it to the Community Workforce Coordinator and to the Council forty-eight (48) hours before the commencement of Project Work, or within forty-eight (48) hours after the award of Project Work to that Contractor (or subcontractor), whichever occurs later.

2.5.3 The District agrees that to the extent permitted by law and consistent with the economy and efficiency of construction and operation, it will use its best efforts to purchase

materials, equipment and supplies which will not create labor strife. Under all circumstances, however, the District shall retain the absolute right to select the lowest reliable and responsible bidder for the award of contracts on all projects.

Section 2.6 Coverage Exception: This Agreement shall not apply if the District receives funding or assistance from any Federal, State, local or other public entity for the Construction Contract if a requirement, condition or other term of receiving that funding or assistance, at the time of the awarding of the contract, is that the District not require, bidders, contractors, subcontractors or other persons or entities to enter into an agreement with one or more labor organizations or enter into an agreement that contains any of the terms set forth herein. The District agrees that it will make every effort to establish the enforcement of this Agreement with any governmental agency or granting authority.

Section 2.7 Master Labor Agreements:

2.7.1 The provisions of this Agreement, including the Master Labor Agreements (which are the local collective bargaining agreements of the signatory Unions having jurisdiction over the work on the Project, as such may be changed from time-to-time and which are incorporated herein by reference) shall apply to the work covered by this Agreement, notwithstanding the provisions of any other local, area and/or national agreement which may conflict with or differ from the terms of this Agreement. However, such does not apply to work performed under the National Cooling Tower Agreement, the National Stack Agreement, the National Transit Division Agreement (NTD), or within the jurisdiction of the International Union of Elevator Constructors and all instrument calibration and loop checking work performed under the terms of the UA/IBEW Joint National Agreement for Instrument and Control Systems Technicians except that Articles dealing with Work Stoppages and Lock-Outs, Work Assignments and Jurisdictional Disputes, and Settlement of Grievances and Disputes shall apply to such work. It is specifically agreed that no later agreement shall be deemed to have precedence over this Agreement unless signed by all Parties signatory hereto who are then currently employed or represented at the Project. Where a subject covered by the provisions of this Agreement is also covered by a Master Labor Agreements, the provisions of this Agreement shall apply. Where a subject is covered by a provision of a Master Labor Agreements and not covered by this Agreement, the provisions of the Master Labor Agreements shall prevail. Any dispute as to the applicable source between this Agreement and any Master Labor Agreements for determining the wages, hours of working conditions of employees on this Project shall be resolved under the procedures established in Article 9.

2.7.2 It is understood that this Agreement, together with the referenced Master Labor Agreements, constitutes a self-contained, stand-alone agreement and by virtue of having become bound to this Community Workforce Agreement, the Contractor will not be obligated to sign any other local, area or national collective bargaining agreement as a condition of performing work within the scope of this Agreement (provided, however, that the Contractor may be required to sign an uniformly applied, non-discriminatory "Subscription Agreement" or "Participation Agreement" at the request of the trustees or administrator of a trust fund established pursuant to Section 302 of the Labor Management Relations Act, and to which such Contractor is bound to make contributions under this Agreement, provided that such Participation Agreement does not purport to bind the Contractor beyond the terms and conditions of this Agreement and/or expand its obligation to make contributions pursuant thereto). It shall be the responsibility of the prime

Contractor to have each of its subcontractors sign such Agreement with the appropriate Craft Union prior to the subcontractor beginning Project Work.

Section 2.8 Binding Signatories Only: This Agreement shall only be binding on the signatory Parties hereto, and shall not apply to the parents, affiliates, subsidiaries, or other ventures of any such Party.

Section 2.9 Other District Work: This Agreement shall be limited to the construction work within the Scope of this Agreement including, specifically, site preparation and related demolition work, and new construction and major rehabilitation work for new or existing facilities referenced in Section 2.2 above. Nothing contained herein shall be interpreted to prohibit, restrict, or interfere with the performance of any other operation, work or function not covered by this Agreement, which may be performed by District employees or contracted for by the District for its own account, on its property or in and around a Project site.

Section 2.10 Separate Liability: It is understood that the liability of the Contractor(s) and the liability of the separate Unions under this Agreement shall be several and not joint. The Unions agree that this Agreement does not have the effect of creating any joint employment status between or among the District or Community Workforce Coordinator and/or any Contractor.

Section 2.11 Completed Project Work: As areas of Project Work are accepted by the District, this Agreement shall have no further force or effect on such items or areas except where the Contractor is directed by the District or its representatives to engage in repairs, modification, check-out and/or warranties functions required by its contract(s) with the District.

### **ARTICLE 3 UNION RECOGNITION AND EMPLOYMENT**

Section 3.1 Recognition: The Contractor recognizes the Council and the Unions as the exclusive bargaining representative for the employees engaged in Project Work.

Section 3.2 Contractor Selection of Employees: The Contractor shall have the right to determine the competency of all employees, the number of employees required, the duties of such employees within their craft jurisdiction, and shall have the sole responsibility for selecting employees to be laid off, consistent with Section 3.3 and Section 4.3, below. The Contractor shall also have the right to reject any applicant referred by a Union for any reason, subject to any reporting pay required by Section 6.6; provided, however, that such right is exercised in good faith and not for the purpose of avoiding the Contractor's commitment to employ qualified workers through the procedures endorsed in this Agreement.

Section 3.3 Referral Procedures:

3.3.1 For signatory Unions now having a job referral system contained in a Master Labor Agreements, the Contractor agrees to comply with such system and it shall be used exclusively by such Contractor, except as modified by this Agreement. Such job referral system will be operated in a nondiscriminatory manner and in full compliance with federal, state, and local laws and regulations which require equal employment opportunities and non-discrimination. All of the foregoing hiring procedures, including related practices affecting

apprenticeship, shall be operated so as to consider the goals of the District to encourage employment of District residents and utilization of small local businesses on the Project, and to facilitate the ability of all Contractors to meet their employment needs.

3.3.2 The Unions will exert their best efforts to recruit and refer sufficient numbers of skilled craft workers to fulfill the labor requirements of the Contractor, including specific employment obligations to which the Contractor may be legally and/or contractually obligated; and to refer apprentices as requested to develop a larger, skilled workforce. The Unions will work with their affiliated regional and national unions, and jointly with the Community Workforce Coordinator and others designated by the District, to identify and refer competent craft persons as needed for Project Work, and to identify and hire individuals, particularly residents of the District, for entrance into joint labor/management apprenticeship programs, or to participation in other identified programs and procedures to assist individuals in qualifying and becoming eligible for such apprenticeship programs, all maintained to increase the available supply of skilled craft personnel for Project Work and future construction of maintenance work to be undertaken by the District.

3.3.3 The Union shall not knowingly refer an employee currently employed by a Contractor on Project Work to any other Contractor.

3.3.4 The Parties are aware of the District's policy that Contractors and other employers shall not employ, on Project Work when minors may be present on or around the site of such Project Work during working hours, a person who would not be eligible for employment by the District under California Educational Code, Section 45123. The Parties shall endeavor to employ persons under this Article in compliance with this policy, and the Contractors agree to remove such an individual in their employ from the particular Project site at the request of the District or the Community Workforce Coordinator.

Section 3.4 Non-Discrimination in Referral, Employment, and Contracting: The Unions and Contractors agree that they will not discriminate against any employee or applicant for employment in hiring and dispatching on the basis of race, color, religion, sex, gender, national origin, age, membership in a labor organization, sexual orientation, political affiliation, marital status or disability. Further, it is recognized that the District has certain policies, programs, and goals for the utilization of local small business enterprises. The Parties shall jointly endeavor to assure that these commitments are fully met, and that any provisions of this Agreement which may appear to interfere within a local and small business enterprises successfully bidding for work within the scope of this Agreement shall be carefully reviewed, and adjustments made as may be appropriate and agreed upon among the Parties, to ensure full compliance with the spirit and letter of the District's policies and commitment to its goals for the significant utilization of local and small businesses as direct Contractors or suppliers for Project Work.

Section 3.5 Employment of District Area Residents:

3.5.1 The Unions and Employers agree that, to the extent allowed by law, and as long as they possess the requisite skills and qualifications, the Unions will exert their best efforts to refer and/or recruit sufficient numbers of qualified area residents, as well as Veterans, regardless of their place of residence, to fulfill the requirements of the Employers. In recognition of the fact that the District and the communities surrounding Project Work will be impacted by the

construction of the Project Work, the parties agree to support the hiring of workers from the residents of these surrounding areas (“Area Residents”), as well as Veterans and individuals who have successfully completed the Building Trades Multi-Craft Core Curriculum Pre-Apprenticeship Program, as well as students which have graduated from the District, regardless of where they reside (collectively “Student Graduates”). Towards that end, the Unions agree that they will exert their best efforts to encourage and provide referrals and utilization of qualified workers:

(i) First, Area Residents residing in those first tier zip codes which cover the District service area, as reflected on the attached list of zip codes on Attachment B, as well as Veterans and Students Graduates, regardless of where they reside;

(ii) If the Unions cannot provide the Employers in the attainment of a sufficient number of qualified workers from paragraph (i), above, the Unions will then exert their best efforts to recruit and identify for referral qualified workers residing within the remainder of the Los Angeles County and the Greater Antelope Valley.

Qualified workers residing within any of these three (3) areas described above, as well as Veterans and Student Graduates, regardless of where they reside, shall be referred to as “Local Residents.”

3.5.2 A goal of 30% of all of the labor and craft positions shall be from Local Residents described in 3.5.1, above. To facilitate the dispatch of Local Residents, all Contractors will be required to utilize the Craft Employee Request Form whenever they are requesting the referral of any employee from a Union referral list for any Project Work, a sample of which is attached as **Attachment “C.”** When Local Residents are requested by the Contractors, the Unions will refer such workers regardless of their place in the Unions’ hiring halls’ list and normal referral procedures. Work performed by residents of states other than California shall not be included in the calculation of the labor and craft positions for purposes of the percentage requirements set forth above.

3.5.3 The Community Workforce Coordinator shall work with the Unions and Contractors in the administration of this Local Resident preference; and the Contractors and Unions shall cooperate by maintaining adequate records to demonstrate to the Community Workforce Coordinator that such preferences have been pursued.

3.5.4 Hours worked by residents of states other than California shall not be included in the calculation of total hours of Project Work for purposes of the percentage requirements set forth above.

Section 3.6 Helmets to Hardhats: The Employers and the Unions recognize a desire to facilitate the entry into the building and construction trades of veterans who are interested in careers in the building and construction industry. The employers and Unions agree to utilize the services of the Center for Military Recruitment, Assessment and Veterans Employment (hereinafter “Center”) and the Center’s “Helmets to Hardhats” program to serve as a resource for preliminary orientation, assessment of construction aptitude, referral to apprenticeship programs or hiring halls, counseling and mentoring, support network, employment opportunities and other needs as identified by the Parties. For purposes of this Agreement, the term “Eligible Veteran”



shall have the same meaning as the term “veteran” as defined under Title 5, Section 2108(1) of the United States Code as the same may be amended or re-codified from time to time. It shall be the responsibility of each qualified District resident to provide the Unions with proof of his/her status as an Eligible Veteran.

The Unions and Employers agree to coordinate with the Center to create and maintain an integrated database of veterans interested in working on this Project and of apprenticeship and employment opportunities for this Project. To the extent permitted by law, the Unions will give credit to such veterans for bona fide, provable past experience.

### Section 3.7 Core Employees:

3.7.1 Except as otherwise provided in separate collective bargaining agreement(s) to which the Contractor is signatory, Contractors may employ, as needed, first, a member of his core workforce, then an employee through a referral from the appropriate Union hiring hall, then a second core employee, then a second employee through the referral system, and so on until a maximum of five (5) core employees are employed in the Contractor’s workforce, thereafter, all additional employees in the affected trade or craft shall be requisitioned from the craft hiring hall in accordance with Section 3.3. In the laying off of employees, the number of core employees shall not exceed one-half plus one of the workforce for an employer with ten (10) or fewer employees, assuming the remaining employees are qualified to undertake the work available. This provision applies only to Contractors who are not directly signatory to a current Master Labor Agreement for the craft worker in its employ and is not intended to limit the transfer provisions of the Master Labor Agreement of any trade. As part of this process, and in order to facilitate the contract administration procedures, as well as appropriate fringe benefit fund coverage, all Contractors shall require their core employees and any other persons employed other than through the referral process, to register with the appropriate Union hiring hall, if any, prior to their first day of employment at a project site.

3.7.2 The core work force is comprised of those employees whose names appeared on the Contractor’s active payroll for sixty (60) of the one hundred (100) working days immediately before award of Project Work to the Contractor; who possess any license required by state or federal law for the Project Work to be performed; who have the ability to safely perform the basic functions of the applicable trade; and have worked a total of at least two thousand (2,000) hours in the specific construction craft during the prior four (4) years.

3.7.3 Prior to each Contractor performing any work on the Project, each Contractor shall provide a list of his core employees to the Community Workforce Coordinator and the Council. Failure to do so will prohibit the Contractor from using any core employees. Upon request by any Party to this Agreement, the Contractor hiring any core employee shall provide satisfactory proof (i.e., payroll records, quarterly tax records, driver’s license, voter registration, postal address and such other documentation) evidencing the core employee’s qualification as a core employee to the Community Workforce Coordinator and the Council.

Section 3.8 Time for Referral: If any Union’s registration and referral system does not fulfill the requirements for specific classifications requested by any Contractor within forty-eight (48) hours (excluding Saturdays, Sundays and holidays), that Contractor may use employment sources other than the Union registration and referral services and may employ applicants

meeting such standards from any other available source. The Contractors shall inform the Union of any applicants hired from other sources within forty-eight (48) hours of such applicant being hired, and such applicants shall register with the appropriate hiring hall, if any.

Section 3.9 Lack of Referral Procedure: If a signatory Union does not have a job referral system as set forth in Section 3.3 above, the Contractors shall give the Union equal opportunity to refer applicants. The Contractors shall notify the Union of employees so hired, as set forth in Section 3.5.

Section 3.10 Union Membership: Employees are not required to become or remain union members or pay dues or fees as a condition of performing Covered Work under this Agreement. Employers shall make and transmit all deductions for union dues, fees, and assessments that have been authorized by employees in writing in accordance with the applicable Master Agreement. Nothing in this Section 3.10 is intended to supersede independent requirements of applicable Master Agreements as to those Employers otherwise signatory to such Master Agreements and as to the employees of those Employers who are performing Covered Work.

Section 3.11 Individual Seniority: Except as provided in Section 4.3, individual seniority shall not be recognized or applied to employees working on the Project; provided, however, that group and/or classification seniority in a Union's Master Labor Agreement as of the effective date of this Agreement shall be recognized for purposes of layoffs.

Section 3.12 Foremen: The selection and number of craft foreman and/or general foreman shall be the responsibility of the Contractor. All foremen shall take orders exclusively from the designated Contractor representatives. Craft foreman shall be designated as working foreman at the request of the Contractors.

Section 3.13 District Security Requirements: The Parties are aware of the District's policy that Contractors and other employers shall not employ a person who would not be eligible for employment by the District under California Education Code, Section 45123. All persons working on Project Work, including all employees hired by a Contractor (or referred by a Signatory Union) to work on Project Work, shall be required to comply with all criminal background check certification requirements and policies of District for those persons who may come in contact with, or work in close proximity to, minors in the course of performing work on a Project. Contractors may refuse to employ any person who declines to comply with District's background check requirements or who is otherwise determined to be disqualified from participating in Project Work because of a disqualifying conviction. Similarly, District may ban or order the immediate removal of any person disqualified from working in the presence of, or in close proximity to, minors.

## **ARTICLE 4 UNION ACCESS AND STEWARDS**

Section 4.1 Access to Project Sites: Authorized representatives of the Union shall have access to Project Work, provided that they do not interfere with the work of employees and

further provided that such representatives fully comply with posted visitor, security and safety rules.

Section 4.2 Stewards:

4.2.1 Each signatory Union shall have the right to dispatch a working journey person as a steward for each shift and shall notify the Contractor in writing of the identity of the designated steward or stewards prior to the assumption of such person's duties as steward. Such designated steward or stewards shall not exercise any supervisory functions. There will be no non-working stewards. Stewards will receive the regular rate of pay for their respective crafts.

4.2.2 In addition to his/her work as an employee, the steward should have the right to receive, but not to solicit, complaints or grievances and to discuss and assist in the adjustment of the same with the employee's appropriate supervisor. Each steward should be concerned only with the employees of the steward's Contractor and, if applicable, subcontractor(s), and not with the employees of any other Contractor. A Contractor will not discriminate against the steward in the proper performance of his/her Union duties.

4.2.3 When a Contractor has multiple, non-contiguous work locations at one site, the Contractor may request and the Union shall appoint such additional working stewards as the Contractor requests to provide independent coverage of one or more such locations. In such cases, a steward may not service more than one work location without the approval of the Contractor.

4.2.4 The stewards shall not have the right to determine when overtime shall be worked or who shall work overtime.

Section 4.3 Steward Layoff/Discharge: The relevant Contractor agrees to notify the appropriate Union twenty-four (24) hours before the layoff of a steward, except in the case of disciplinary discharge for just cause. If the steward is protected against such layoff by the provisions of the applicable Master Labor Agreement, such provisions shall be recognized when the steward possesses the necessary qualifications to perform the remaining work. In any case in which the steward is discharged or disciplined for just cause, the appropriate Union will be notified immediately by the Contractor, and such discharge or discipline shall not become final (subject to any later filed grievance) until twenty-four (24) hours after such notice has been given.

Section 4.4 Employees on Non-Project Work: On work where the personnel of the District may be working in close proximity to the construction activities covered by this Agreement, the Union agrees that the Union representatives, stewards, and individual workers will not interfere with the District personnel, or with personnel employed by the any other employer not a Party to this Agreement.

**ARTICLE 5  
WAGES AND BENEFITS**

Section 5.1 Wages: All employees covered by this Agreement shall be classified in accordance with work performed and paid by the Contractors the hourly wage rates for those



classifications in compliance with the applicable prevailing wage rate determination established pursuant to applicable law. If a prevailing rate increases under law, the Contractor shall pay that rate as of its effective date under the law. Notwithstanding any other provision of this Agreement, this Agreement does not relieve Contractors directly signatory to one or more of the Master Labor Agreements from paying all wages set forth in such Agreements.

## Section 5.2 Benefits:

5.2.1 Contractors shall pay contributions to the established employee benefit funds in the amounts designated in the appropriate Master Labor Agreement and make all employee authorized deductions in the amounts designated in the appropriate Master Labor Agreement; provided, however, that such contributions shall not exceed the contribution amounts set forth in the applicable prevailing wage determination. Notwithstanding any other provision of this Agreement, Contractors directly signatory to one or more of the Master Labor Agreements are required to make all contributions set forth in those Master Labor Agreements without reference to the forgoing. Bona fide benefit plans with joint trustees or authorized employee deduction programs established or negotiated under the applicable Master Labor Agreement or by the Parties to this Agreement during the life of this Agreement may be added.

5.2.2 The Contractor adopts and agrees to be bound by the written terms of the applicable, legally established, trust agreement(s) specifying the detailed basis on which payments are to be made into, and benefits paid out of, such trust funds for its employees. The Contractor authorizes the Parties to such trust funds to appoint trustees and successor trustees to administer the trust funds and hereby ratifies and accepts the trustees so appointed as if made by the Contractor.

5.2.3 Each Contractor and subcontractor is required to certify to the Community Workforce Coordinator that it has paid all benefit contributions due and owing to the appropriate Trust(s) prior to the receipt of its final payment and/or retention. Further, upon timely notification by a Union to the Community Workforce Coordinator, the Community Workforce Coordinator shall work with any prime Contractor or subcontractor who is delinquent in payments to assure that proper benefit contributions are made, to the extent of requesting the District or the prime Contractor to withhold payments otherwise due such Contractor, until such contributions have been made or otherwise guaranteed.

Section 5.3 Wage Premiums: Wage premiums, including but not limited to pay based on height of work, hazard pay, scaffold pay and special skills shall not be applicable to work under this Agreement, except to the extent provided for in any applicable prevailing wage determination.

Section 5.4 Compliance with Prevailing Wage Laws: The Parties agree that the Community Workforce Coordinator shall monitor the compliance by all Contractors and subcontractors with all applicable federal and state prevailing wage laws and regulations, and that such monitoring shall include Contractors engaged in what would otherwise be Project Work but for the exceptions to Agreement coverage in Section 2.2. All complaints regarding possible prevailing wage violations shall be referred to the Community Workforce Coordinator for processing, investigation and resolution, and if not resolved within thirty (30) calendar days, may be referred by any party to the state labor commissioner.

## **ARTICLE 6 WORK STOPPAGES AND LOCK-OUTS**

Section 6.1 No Work Stoppages or Disruptive Activity: The Council and the Unions agree that neither they, and each of them, nor their respective officers or agents or representatives, shall incite or encourage, condone or participate in any strike, walk-out, slow-down, picketing, observing picket lines or other activity of any nature or kind whatsoever, for any cause or dispute whatsoever with respect to or in any way related to Project Work, or which interferes with or otherwise disrupts Project Work, or with respect to or related to the District or Contractors or subcontractors, including, but not limited to economic strikes, unfair labor practice strikes, safety strikes, sympathy strikes and jurisdictional strikes whether or not the underlying dispute is subject to arbitration. Any such actions by the Council, or Unions, or their members, agents, representatives or the employees they represent shall constitute a violation of this Agreement. The Council and the Union shall take all steps necessary to obtain compliance with this Article and neither should be held liable for conduct for which it is not responsible.

Section 6.2 Employee Violations: The Contractor may discharge any employee violating Section 6.1 above and any such employee will not be eligible for rehire under this Agreement.

Section 6.3 Standing to Enforce: The District, the Community Workforce Coordinator, or any Contractor affected by an alleged violation of Section 6.1 shall have standing and the right to enforce the obligations established therein.

Section 6.4 Expiration of Master Labor Agreements: If the Master Labor Agreement, or any local, regional, and other applicable collective bargaining agreements expire during the term of the Project, the Union(s) agree that there shall be no work disruption of any kind as described in Section 6.1 above as a result of the expiration of any such agreement(s) having application on this Project and/or failure of the involved Parties to that agreement to reach a new contract. Terms and conditions of employment established and set at the time of bid shall remain established and set. Otherwise to the extent that such agreement does expire and the Parties to that agreement have failed to reach concurrence on a new contract, work will continue on the Project on one of the following two (2) options, both of which will be offered by the Unions involved to the Contractors affected:

6.4.1 Each of the Unions with a contract expiring must offer to continue working on the Project under interim agreements that retain all the terms of the expiring contract, except that the Unions involved in such expiring contract may each propose wage rates and employer contribution rates to employee benefit funds under the prior contract different from what those wage rates and employer contributions rates were under the expiring contracts. The terms of the Union's interim agreement offered to Contractors will be no less favorable than the terms offered by the Union to any other employer or group of employers covering the same type of construction work in Los Angeles County.

6.4.2 Each of the Unions with a contract expiring must offer to continue working on the Project under all the terms of the expiring contract, including the wage rates and employer contribution rates to the employee benefit funds, if the Contractor affected by that expiring contract agrees to the following retroactive provisions: if a new Master Labor Agreement, local, regional or other applicable labor agreement for the industry having application at the Project is

ratified and signed during the term of this Agreement and if such new labor agreement provides for retroactive wage increases, then each affected Contractor shall pay to its employees who performed work covered by this Agreement at the Project during the hiatus between the effective dates of such expired and new labor agreements, an amount equal to any such retroactive wage increase established by such new labor agreement, retroactive to whatever date is provided by the new labor agreement for such increase to go into effect, for each employee's hours worked on the Project during the retroactive period. All Parties agree that such affected Contractors shall be solely responsible for any retroactive payment to its employees.

6.4.3 Some Contractors may elect to continue to work on the Project under the terms of the interim agreement option offered under paragraph 6.4.1, above and other Contractors may elect to continue to work on the Project under the retroactivity option offered under paragraph 6.4.2, above. To decide between the two options, Contractors will be given one week after the particular labor agreement has expired or one week after the Union has personally delivered to the Contractors in writing its specific offer of terms of the interim agreement pursuant to paragraph 6.4.1 above, whichever is the later date. If the Contractor fails to timely select one of the two options, the Contractor shall be deemed to have selected option 6.4.2.

Section 6.5 No Lockouts: Contractors shall not cause, incite, encourage, condone or participate in any lock-out of employees with respect to Project Work during the term of this Agreement. The term "lock-out" refers only to a Contractor's exclusion of employees in order to secure collective bargaining advantage, and does not refer to the discharge, termination or layoff of employees by the Contractor for any reason in the exercise of rights pursuant to any provision of this Agreement, or any other agreement, nor does "lock-out" include the District's decision to stop, suspend or discontinue any Project Work or any portion thereof for any reason.

Section 6.6 Best Efforts to End Violations:

6.6.1 If a Contractor contends that there is any violation of this Article or Section 7.3, it shall notify, in writing, the Executive Secretary of the Council, the Senior Executive of the involved Union(s) and the Community Workforce Coordinator. The Executive Secretary and the leadership of the involved Union(s) will immediately instruct, order and use their best efforts to cause the cessation of any violation of the relevant Article.

6.6.2 If the Union contends that any Contractor has violated this Article, it will notify the Contractor and the Community Workforce Coordinator, setting forth the facts which the Union contends violate the Agreement, at least twenty-four (24) hours prior to invoking the procedures of Section 7.8. The Community Workforce Coordinator shall promptly order the involved Contractor(s) to cease any violation of the Article.

Section 6.7 Withholding of services for failure to pay wages and fringe benefits: Notwithstanding any provision of this Agreement to the contrary, it shall not be a violation of this Agreement for any Union to withhold the services of its members (but not the right to picket) from a particular Contractor who:

6.7.1 fails to timely pay its weekly payroll; or

6.7.2 fails to make timely payments to the Union's Joint Labor/Management Trust Funds in accordance with the provisions of the applicable Master Labor Agreements. Prior to withholding its members' services for the Contractor's failure to make timely payments to the Union's Joint Labor/Management Trust Funds, the Union shall give at least ten (10) days (unless a lesser period of time is provided in the Union's Master Labor Agreement, but in no event less than forty-eight (48) hours) written notice of such failure to pay by registered or certified mail, return receipt requested, and by facsimile transmission to the involved Contractor and the District. Union will meet within the ten (10) day period to attempt to resolve the dispute.

6.7.3 Upon the payment of the delinquent Contractor of all monies due and then owing for wages and/or fringe benefit contributions, the Union shall direct its members to return to work and the Contractor shall return all such members back to work.

Section 6.8 Expedited Enforcement Procedure: Any party, including the District, which is an intended beneficiary of this Article, or the Community Workforce Coordinator, may institute the following procedures, in lieu of or in addition to any other action at law or equity, when a breach of Section 6.1, 6.5 or Section 7.3 is alleged.

6.8.1 The party invoking this procedure shall notify Lou Zigman, who has been selected by the negotiating Parties, and whom the Parties agree shall be the permanent arbitrator under this procedure. If the permanent arbitrator is unavailable at any time, the party invoking this procedure shall notify one of the alternates selected by the Parties, in that order on an alternating basis. Notice to the arbitrator shall be by the most expeditious means available, with notices to the Parties alleged to be in violation, and to the Council if it is a Union alleged to be in violation. For purposes of this Article, written notice may be given by telegram, facsimile, hand-delivery or overnight mail and will be deemed effective upon receipt.

6.8.2 Upon receipt of said notice, the arbitrator named above or his/her alternate shall sit and hold a hearing within twenty-four (24) hours if it is contended that the violation still exists, but not sooner than twenty-four (24) hours after notice has been dispatched to the Council of the involved Union(s) and/or Contractor as required by Section 8.6, above.

6.8.3 The arbitrator shall notify the Parties of the place and time chosen for this hearing. Said hearing shall be completed in one session, which, with appropriate recesses at the arbitrator's discretion, shall not exceed twenty-four (24) hours unless otherwise agreed upon by all Parties. A failure of any Party or Parties to attend said hearings shall not delay the hearing of evidence or the issuance of any award by the arbitrator.

6.8.4 The sole issue at the hearing shall be whether or not a violation of Sections 6.1, 6.5 or Section 7.3 has in fact occurred. The arbitrator shall have no authority to consider any matter in justification, explanation or mitigation of such violation or to award damages. The Award shall be issued in writing within three (3) hours after the close of the hearing and may be issued without an opinion. If any party desires a written opinion, one shall be issued within fifteen (15) days, but its issuance shall not delay compliance with, or enforcement of, the Award. The arbitrator may order cessation of the violation of the Article and other appropriate relief, and such Award, upon issuance, shall be served on all Parties by hand or registered mail.

6.8.5 Such Award shall be final and binding on all Parties and may be enforced by any court of competent jurisdiction upon the filing of this Agreement and all other relevant documents referred to herein above in the following manner. Written notice of the filing of such enforcement proceedings shall be given to the other party. In any judicial proceeding to obtain a temporary order enforcing the arbitrator's Award as issued under Section 6.8(d) of this Article, all Parties waive the right to a hearing and agree that such proceedings may be ex parte. Such agreement does not waive any Party's right to participate in a hearing for a final order of enforcement. The court's order or orders enforcing the arbitrator's award shall be served on all Parties by hand or by delivery to their address as shown on this Agreement (for a Union), as shown in their business contract for work under this Agreement (for a Contractor) and to the representing Union (for an employee), by certified mail by the Party or Parties first alleging the violation.

6.8.6 Any rights created by statute or law governing arbitration proceedings inconsistent with the above procedure or which interfere with compliance hereto are hereby waived by the Parties to whom they accrue.

6.8.7 The fees and expenses of the arbitrator shall be equally divided between the party or Parties initiating this procedure and the respondent Party or Parties.

## **ARTICLE 7 WORK ASSIGNMENTS AND JURISDICTIONAL DISPUTES**

Section 7.1 Assignment of Work: The assignment of Project Work will be solely the responsibility of the Employer performing the work involved; and such work assignments will be in accordance with the Plan for the Settlement of Jurisdictional Disputes in the Construction Industry (the "Plan") or any successor Plan.

Section 7.2 The Plan: All jurisdictional disputes on this Project between or among the building and construction trades Unions and the Employers parties to this Agreement, shall be settled and adjusted according to the present Plan established by the Building and Construction Trades Department or any other plan or method of procedure that may be adopted in the future by the Building and Construction Trades Department. Decisions rendered shall be final, binding and conclusive on the Employers and Unions parties to this Agreement.

Section 7.3 If a dispute arising under this Article involves the Southwest Mountain States Regional Council of Carpenters or any of its subordinate bodies, an Arbitrator shall be chosen by the procedures specified in Article V, Section 5, of the Plan from a list composed of John Kagel, Robert Hirsch, and Thomas Pagan, and the Arbitrator's hearing on the dispute shall be held at the offices of the applicable Building and Construction Trades Council within fourteen (14) days of the selection of the Arbitrator. All other procedures shall be as specified in the Plan.

Section 7.4 No Work Disruption Over Jurisdiction: All jurisdictional disputes shall be resolved without the occurrence of any strike, work stoppage, or slow-down of any nature, and the Employer's assignment shall be adhered to until the dispute is resolved. Individuals violating this section shall be subject to immediate discharge.



Section 7.5 Pre-Job Conferences: As provided in Article 16, each Employer will conduct a pre-job conference with the Council prior to commencing work. The Primary Employer and the Owner will be advised in advance of all such conferences and may participate if they wish. Pre-job conferences for different Employers may be held together.

Section 7.6 Resolution of Jurisdictional Disputes: If any actual or threatened strike, sympathy strike, work stoppage, slow down, picketing, hand-billing or otherwise advising the public that a labor dispute exists, or interference with the progress of Project Work by reason of a jurisdictional dispute or disputes occurs, the Parties shall exhaust the expedited procedures set forth in the Plan, if such procedures are in the plan then currently in effect, or otherwise as in Article 6 above.

## **ARTICLE 8 MANAGEMENT RIGHTS**

Section 8.1 Contractor Rights: The Contractors retain the full and exclusive authority for the management of their operations, as set forth in this Article, unless expressly limited or required by a specific provision of this Agreement or an applicable Master Labor Agreement. The Contractor's rights include, but are not limited to, the right to:

8.1.1 Plan, direct and control operations of all work;

8.1.2 Hire, promote, transfer and layoff their own employees, respectively, as deemed appropriate to satisfy work and/or skill requirements;

8.1.3 Promulgate and require all employees to observe reasonable job rules and security and safety regulations;

8.1.4 Discharge, suspend or discipline their own employees for just cause;

8.1.5 Utilize, in accordance with District approval, any work methods, procedures or techniques, and select, use and install any types or kinds of materials, apparatus or equipment, regardless of source of manufacture or construction; assign and schedule work at their discretion; and

8.1.6 Assign overtime, determine when it will be worked and the number and identity of employees engaged in such work, subject to such provisions in the applicable Master Labor Agreement(s) requiring such assignments be equalized or otherwise made in a nondiscriminatory manner.

Section 8.2 Specific District Rights: In addition to the following and other rights of the District enumerated in this Agreement, the District expressly reserves its management rights and all the rights conferred on it by law. The District's rights (and those of the Contractor Administrator on its behalf) include but are not limited to the right to:

8.2.1 Inspect any construction site or facility to ensure that the Contractor follows the applicable safety and other work requirements;

8.2.2 Require Contractors to establish a different work week or shift schedule for particular employees as required to meet the operational needs of the Project Work at particular locations;

8.2.3 At its sole option, terminate, delay and/or suspend any and all portions of the Project Work at any time; prohibit some or all work on certain days or during certain hours of the day to accommodate the ongoing operations of the District's educational facilities and/or to mitigate the effect of ongoing Project Work on businesses and residents in the neighborhood of the Project site; and/or require such other operational or schedule changes it deems necessary, in its sole judgment, to effectively maintain its primary mission and remain a good neighbor to those in the area of its facilities. (In order to permit the Contractors and Unions to make appropriate scheduling plans, the District will provide the Community Workforce Coordinator, and the affected Contractor(s) and Union(s) with reasonable notice of any changes it requires pursuant to this section; provided, however, that if notice is not provided in time to advise employees not to report for work, show-up pay shall be due pursuant to the provisions of the applicable Master Labor Agreement);

8.2.4 Approve any work methods, procedures and techniques used by Contractors whether or not these methods, procedures or techniques are part of industry practices or customs; and

8.2.5 Investigate and process complaints, through its Community Workforce Coordinator, in the matters set forth in Articles 6 and 9.

Section 8.3 Use of Materials: There should be no limitations or restriction by Union upon a Contractor's choice of materials or design, nor, regardless of source or location, upon the full use and utilization, of equipment, machinery, packaging, precast, prefabricated, prefinished, or preassembled materials, tools or other labor saving devices, subject to the application of the State Public Contracts and Labor Codes as required by law in reference to offsite construction. Generally, the onsite installation or application of such items shall be performed by the craft having jurisdiction over such work. The District and its Community Workforce Coordinator shall advise all Contractors of, and enforce as appropriate, the off-site application of the prevailing wage law as it affects Project Work.

Section 8.4 Special Equipment, Warranties and Guaranties:

8.4.1 It is recognized that certain equipment of a highly technical and specialized nature may be installed at Project Work sites. The nature of the equipment, together with the requirements for manufacturer's warranties, may dictate that it be prefabricated, pre-piped and/or pre-wired and that it be installed under the supervision and direction of the District's and/or manufacturer's personnel. The Unions agree to install such equipment without incident.

8.4.2 The Parties recognize that the Contractor will initiate from time to time the use of new technology, equipment, machinery, tools, and other labor-savings devices and methods of performing Project Work. The Union agrees that they will not restrict the implementation of such devices or work methods. The Unions will accept and will not refuse to handle, install or work with any standardized and/or catalogue: parts, assemblies, accessories, prefabricated items,

preassembled items, partially assembled items, or materials whatever their source of manufacture or construction.

8.4.3 If any disagreement between the Contractor and the Unions concerning the methods of implementation or installation of any equipment, or device or item, or method of work, arises, or whether a particular part or pre-assembled item is a standardized or catalog part or item, the work will precede as directed by the Contractor and the Parties shall immediately consult over the matter. If the disagreement is not resolved, the affected Union(s) shall have the right to proceed through the procedures set forth in Article 9.

## **ARTICLE 9 SETTLEMENT OF GRIEVANCES AND DISPUTES**

### **Section 9.1 Cooperation and Harmony on Site:**

9.1.1 This Agreement is intended to establish and foster continued close cooperation between management and labor. The Council shall assign a representative to this Project for the purpose of assisting the Unions, and working with the Community Workforce Coordinator, together with the Contractors, to complete the construction of the Project economically, efficiency, continuously and without any interruption, delays or work stoppages.

9.1.2 The Community Workforce Coordinator, the Contractors, Unions, and employees collectively and individually, realize the importance to all Parties of maintaining continuous and uninterrupted performance Project Work, and agree to resolve disputes in accordance with the grievance provisions set forth in this Article or, as appropriate, those of Article 7 or 8.

9.1.3 The Community Workforce Coordinator shall oversee the processing of grievances under this Article and Articles 6 and 7, including the scheduling and arrangements of facilities for meetings, selection of the arbitrator from the agreed-upon panel to hear the case, and any other administrative matters necessary to facilitate the timely resolution of any dispute; provided, however, it is the responsibility of the principal parties to any pending grievance to insure the time limits and deadlines are met.

Section 9.2 Processing Grievances: Any questions arising out of and during the term of this Agreement involving its interpretation and application, which includes applicable provisions of the Master Labor Agreements, but not jurisdictional disputes or alleged violations of Section 6.1 and 6.5 and similar provisions, shall be considered a grievance and subject to resolution under the following procedures.

Step 1. Employee Grievances: When any employee subject to the provisions of this Agreement feels aggrieved by an alleged violation of this Agreement, the employee shall, through his Union business representative or, job steward, within ten (10) working days after the occurrence of the violation, give notice to the work site representative of the involved Contractor stating the provision(s) alleged to have been violated. A business representative of the Union or the job steward and the work site representative of the involved Contractor shall meet and endeavor to adjust the matter within ten (10) working days after timely notice has been given. If they fail to resolve the matter within the prescribed period, the grieving party may, within ten (10) working days thereafter, pursue Step 2 of this grievance procedure provided the grievance is



reduced to writing, setting forth the relevant information, including a short description thereof, the date on which the alleged violation occurred, and the provision(s) of the Agreement alleged to have been violated. Grievances and disputes settled at Step 1 shall be non-precedential except as to the parties directly involved.

Union or Contractor Grievances: Should the Union(s) or any Contractor have a dispute with the other Party(ies) and, if after conferring within ten (10) working days after the disputing Party knew or should have known of the facts or occurrence giving rise to the dispute, a settlement is not reached within five (5) working days, the dispute shall be reduced to writing and processed to Step 2 in the same manner as outlined in 1(a) above for the adjustment of an employee complaint.

Step 2. The business manager of the involved Union or his designee, together with the site representative of the involved Contractor, and the labor relations representative of the Community Workforce Coordinator, shall meet within seven (7) working days of the referral of the dispute to this second step to arrive at a satisfactory settlement thereof. If the Parties fail to reach an agreement, the dispute may be appealed in writing in accordance with the provisions of Step 3 within seven (7) calendar days after the initial meeting at Step 2.

Step 3. (a) If the grievance shall have been submitted but not resolved under Step 2, either the Union or Contractor Party may request in writing to the Community Workforce Coordinator (with copy (ies) to the other Party (ies)) within seven (7) calendar days after the initial Step 2 meeting, that the grievance be submitted to an arbitrator selected from the agreed upon list below, on a rotational basis in the order listed. Those arbitrators are: (1) Louis Zigman; (2) Walt Daugherty; (3) Fredric Horowitz; (4) Edna Francis; and (5) William Rule. The decision of the arbitrator shall be final and binding on all Parties and the fee and expenses of such arbitrations shall be borne equally by the involved Contractor(s) and the involved Union(s).

(b) Failure of the grieving Party to adhere to the time limits established herein shall render the grievance null and void. The time limits established herein may be extended only by written consent of the Parties involved at the particular step where the extension is agreed upon. The arbitrator shall have the authority to make decisions only on issues presented and shall not have the authority to change, amend, add to or detract from any of the provisions of this Agreement.

(c) The fees and expenses incurred by the arbitrator, as well as those jointly utilized by the Parties (i.e., conference room, court reporter, etc.) in arbitration, shall be divided equally by the Parties to the arbitration, including Union(s) and Contractor(s) involved.

Section 9.3 Limit on Use of Procedures: Procedures contained in this Article shall not be applicable to any alleged violation of Articles 6 or 7, with a single exception that any employee discharged for violation of Section 6.2, or Section 7.3, may resort to the procedures of this Article to determine only if he/she was, in fact, engaged in that violation.

Section 9.4 Notice: The Community Workforce Coordinator (and the District, in the case of any grievance regarding the Scope of this Agreement) shall be notified by the involved Contractor of all actions at Steps 2 and 3, and further, the Community Workforce Coordinator

shall, upon its own request, be permitted to participate fully as a party in all proceedings at such steps.

## **ARTICLE 10 REGULATORY COMPLIANCE**

Section 10.1 Compliance with All Laws: The Council and all Unions, Contractors, subcontractors and their employed shall comply with all applicable federal and state laws, ordinances and regulations including, but not limited to, those relating to safety and health, employment and applications for employment. All employees shall comply with the safety regulations established by the District, the Community Workforce Coordinator or the Contractor. Employees must promptly report any injuries or accidents to a supervisor.

Section 10.2 Monitoring Compliance: The Parties agree that the District shall require, and that the Community Workforce Coordinator and Council shall monitor, compliance by all Contractors and subcontractors with all federal and state laws regulation that, from time to time may apply to Project Work. It shall be the responsibility of both the Council and the Community Workforce Coordinator (on behalf of the District) to investigate or monitor compliance with these various laws and regulations. The Council may recommend to the Community Workforce Coordinator and/or the District procedures to encourage and enforce compliance with these laws and regulations.

Section 10.3 Prevailing Wage Compliance: The Council or Union shall refer all complaints regarding any potential prevailing wage violation to the Community Workforce Coordinator, who on its own, or with the assistance of the District's labor compliance program, shall process, investigate and resolve such complaints, consistent with Article 5, Section 5.4. The Council or Union, as appropriate, shall be advised in a timely manner with regard to the facts and resolution, if any, of any complaint. It is understood that this Section does not restrict any individual rights as established under the State Labor Code, including the rights of an individual to file a complaint with the State Labor Commissioner or to file a grievance for such violation under the grievance procedure set forth in this Agreement.

Section 10.4 Violations of Law: Based upon a finding of violation by the District of a federal and state law, and upon notice to the Contractor that it or its subcontractors are in such violation, the District, in the absence of the Contractor or subcontractor remedying such violation, shall take such action as it is permitted by law or contract to encourage that Contractor to come into compliance, including, but not limited to, assessing fines and penalties, and/or removing the offending Contractor from Project Work. Additionally, in accordance with the Agreement between the District and the Contractor, the District may cause the Contractor to remove from Project Work any subcontractor who is in violation of state or federal law.

## **ARTICLE 11 SAFETY AND PROTECTION OF PERSON AND PROPERTY**

Section 11.1 Safety:

11.1.1 It shall be the responsibility of each Contractor to ensure safe working conditions and employee compliance with any safety rules contained herein or established by the District,

the Community Workforce Coordinator or the Contractor. It is understood that employees have an individual obligation to use diligent care to perform their work in a safe manner and to protect themselves and the property of the Contractor and the District.

11.1.2 Employees shall be bound by the safety, security and visitor rules established by the Contractor, the Community Workforce Coordinator and/or the District. These rules will be published and posted. An employee's failure to satisfy his/her obligations under this section will subject him/her to discipline, up to and including discharge.

11.1.3 The Parties to this Agreement adopt the Los Angeles/Orange Counties Building and Construction Trades Council Approved Drug and Alcohol Testing Policy, a copy of which is attached hereto as **Attachment "D,"** and which shall be the policy and procedure utilized under this Agreement.

Section 11.2 Suspension of Work for Safety: A Contractor may suspend all or a portion of the job to protect the life and safety of employees. In such cases, employees will be compensated only for the actual time worked; provided, however, that where the Contractor requests employees to remain at the site and be available for work, the employees will be compensated for stand-by time at their basic hourly rate of pay.

Section 11.3 Water and Sanitary Facilities: The Contractor shall provide adequate supplies of drinking water and sanitary facilities for all employees as required by state law or regulation.

## **ARTICLE 12 TRAVEL AND SUBSISTENCE**

Travel expenses, travel time, subsistence allowances, zone rates and parking reimbursements shall be paid in accordance with the applicable Master Labor Agreement unless superseded by the applicable prevailing wage determination.

## **ARTICLE 13 APPRENTICES**

Section 13.1 Importance of Training: The Parties recognize the need to maintain continuing support of the programs designed to develop adequate numbers of competent workers in the construction industry, the obligation to capitalize on the availability of the local work force in the area served by the District, and the opportunities to provide continuing work under the construction program. To these ends, the Parties will facilitate, encourage, and assist local residents to commence and progress in Labor/Management Apprenticeship and/or training Programs in the construction industry leading to participation in such apprenticeship programs. The District, the Community Workforce Coordinator, other District consultants, and the Council, will work cooperatively to identify, or establish and maintain, effective programs and procedures for persons interested in entering the construction industry and which will help prepare them for the formal joint labor/management apprenticeship programs maintained by the signatory Unions.

Section 13.2 Use of Apprentices:

13.2.1 Apprentices used on Projects under this Agreement shall be registered in Joint Labor Management Apprenticeship Programs approved by the State of California. Apprentices may comprise up to thirty percent (30%) of each craft's work force at any time, unless the standards of the applicable joint apprenticeship committee confirmed by the Division of Apprenticeship Standards ("DAS"), establish a lower or higher maximum percentage, and where such is the case, the applicable Union should use its best efforts with the Joint Labor Management apprenticeship committee and, if necessary, the DAS to permit up to thirty percent (30%) apprentices on the Project.

13.2.2 The Unions agree to cooperate with the Contractor in furnishing apprentices as requested up to the maximum percentage. The apprentice ratio for each craft shall be in compliance, at a minimum, with the applicable provisions of the Labor Code relating to utilization of apprentices. The District shall encourage such utilization, and, both as to apprentices and the overall supply of experienced workers, the Community Workforce Coordinator will work with the Council to assure appropriate and maximum utilization of apprentices and the continuing availability of both apprentices and journey persons.

13.2.3 The Parties agree that apprentices will not be dispatched to Contractors working under this Agreement unless there is a journeyman working on the project where the apprentice is to be employed who is qualified to assist and oversee the apprentice's progress through the program in which he is participating.

13.2.4 All apprentices shall work under the direct supervision of a journeyman from the trade in which the apprentice is indentured. A journeyman shall be defined as set forth in the California Code of Regulations, Title 8 [apprenticeship], Section 205, which defines a journeyman as a person who has either completed an accredited apprenticeship in his or her craft, or has completed the equivalent of an apprenticeship in length and content of work experience and all other requirements in the craft which has workers classified as journeyman in the apprenticeship occupation. Should a question arise as to a journeyman's qualification under this subsection, the Contractor shall provide adequate proof evidencing the worker's qualification as a journeyman to the Construction Manager and the Council.

## **ARTICLE 14**

### **WORK OPPORTUNITIES PROGRAM**

Section 14.1 The Parties to this Agreement support the development of increased numbers of skilled construction workers from among Area Residents to meet the labor needs of the Project, specifically, and the requirements of the local construction industry generally. Towards that end the Parties agree to cooperate respecting the establishment of a work opportunities program for Area Residents, the primary goals of which shall be to maximize construction work opportunities for traditionally underrepresented members of the community. In furtherance of the foregoing, the Unions specifically agree to:

14.1.1 Encourage the referral and utilization, to the extent permitted by law and hiring hall practices, of qualified Area Residents as journeymen, and apprentices on the Project and entrance into such qualified apprenticeship and training programs as may be operated by signatory Unions; and

14.1.2 Work cooperatively with the District and other District consultants to identify, or establish and maintain, effective programs, events and procedures for persons interested in entering the construction industry; and

14.1.3 Participate in District based job fairs, career days and outreach events; and

14.1.4 Provide speakers to speak at District programs and Academies as requested; and

14.1.5 Assist Area Residents in contacting pre-apprenticeship programs that utilize the Building Trades multi-craft core curriculum (MC3) and the Apprenticeship Training Committees for the crafts and trades they are interested in. The Unions shall assist Area Residents who are seeking Union jobs on the Project and Union membership in assessing their work experience and giving them credit for provable past experience in their relevant craft or trade, including experience gained working for non-union Contractors. The Unions shall put on their rolls qualified bona fide Area Residents for work on this Project; and

14.1.6 Allow tours of their JACs as requested; and

14.1.7 Provide a contact information list for all Union representatives and Joint Apprenticeship Committee representatives; and

14.1.8 Support local events and programs designed to recruit and develop adequate numbers of competent workers in the construction industry.

## **ARTICLE 15 WORKING CONDITIONS**

Section 15.1 Meal and Rest Periods: There will be no non-working times established during working hours except as may be required by applicable state law or regulations. Meal periods and Rest periods shall be as provided for in Wage Order 16. Individual coffee containers will be permitted at the employees' work location; however, there will be no organized coffee breaks.

Section 15.2 Work Rules: The District, the Community Workforce Coordinator, and/or relevant Contractor shall establish such reasonable work rules as they deem appropriate and not inconsistent with this Agreement. These rules will be posted at the work sites by the Contractor and may be amended thereafter as necessary. Failure to observe these rules and regulations by employees may be grounds for discipline up to an including discharge.

Section 15.3 Emergency Use of Tools and Equipment: There should be no restrictions on the emergency use of any tools by any qualified employee or supervisor, or on the use of any tools or equipment for the performance of work within the jurisdiction, provided the employee can safely use the tools and/or equipment involved and is compliance with applicable governmental rules and regulations.

Section 15.4 Access Restrictions for Cars: Recognizing the nature of the work being conducted on the site, employee access by a private automobile may be limited to certain roads and/or parking areas.

## **ARTICLE 16 PRE-JOB CONFERENCES**

Each Contractor will conduct a pre-job conference with the Unions not later than fourteen (14) calendar days prior to commencing work. The purpose of the conference will be to, among other things, determine craft manpower needs, schedule of work for the contract and project work rules/owner rules. The Council, the Community Workforce Coordinator, and the District shall be advised in advance of all such conferences and may participate if they wish. All work assignments shall be disclosed by the Prime Contractor and all Contractors at a pre-job conference. Should there be Project Work that was not previously discussed at the pre-job conference, or additional project work be added, the contractors performing such work will conduct a separate pre-job conference for such newly included work. Any Union in disagreement with the proposed assignment shall notify the Contractor of its position in writing, with a copy to Community Workforce Coordinator, within seven (7) calendar days thereafter. Within seven (7) calendar days after the period allowed for Union notices of disagreement with the Contractor's proposed assignments, but prior to the commencement of any work, the Contractor shall make final assignments in writing with copies to the Council and to the Community Workforce Coordinator.

## **ARTICLE 17 LABOR/MANAGEMENT COOPERATION**

Section 17.1 Joint Committee: The Parties to this Agreement may establish a six (6) person Joint Administrative Committee (JAC). This JAC shall be comprised of three (3) representatives selected by the District and three (3) representatives selected by the Council to monitor compliance with the terms and conditions of this Agreement. Each representative shall designate an alternate who shall serve in his or her absence for any purpose contemplated by this Agreement.

Section 17.2 Functions of Joint Committee: The Committee shall meet on a schedule to be determined by the Committee or at the call of the joint chairs, to discuss the administration of the Agreement, the progress of the Project, general labor management problems that may arise, and any other matters consistent with this Agreement. Substantive grievances or disputes arising under Articles 6, 7 or 9 shall not be reviewed or discussed by this Committee, but shall be processed pursuant to the provisions of the appropriate Article. The Community Workforce Coordinator shall be responsible for the scheduling of the meetings, the preparation of the agenda topics for the meetings, with input from the Unions the Contractors and the District. Notice of the date, time and place of meetings, shall be given to the Committee members at least three (3) days prior to the meeting. The District should be notified of the meetings and invited to send a representative(s) to participate. The Community Workforce Coordinator shall prepare quarterly reports on apprentice utilization and the training and employment of District residents, and a schedule of Project Work and estimated number of craft workers needed. The Committee or an appropriate subcommittee, may review such reports and make any recommendations for improvement, if necessary, including increasing the availability of skilled trades, and the employment of local residents or other individuals who should be assisted with appropriate training to qualify for apprenticeship programs.



Section 17.3 Subcommittees: The Committee may form subcommittees to consider and advise the full Committee with regard to safety and health issues affecting the Project and other similar issues affecting the overall Project, including any workers' compensation program initiated under this Agreement.

## **ARTICLE 18 SAVINGS AND SEPARABILITY**

Section 18.1 Savings Clause: It is not the intention of the District, the Community Workforce Coordinator, Contractor or the Union parties to violate any laws governing the subject matter of this Agreement. The Parties hereto agree that in the event any provision of this Agreement is finally held or determined to be illegal or void as being in contravention of any applicable law or regulation, the remainder of the Agreement shall remain in full force and effect unless the part or parts so found to be void are wholly inseparable from the remaining portions of this Agreement. Further, the Parties agree that if and when any provision(s) of this Agreement is finally held or determined to be illegal or void by a court of competent jurisdiction, the Parties will promptly enter into negotiations concerning the substantive effect of such decision for the purposes of achieving conformity with the requirements of any applicable laws and the intent of the Parties hereto. If the legality of this Agreement is challenged and any form of injunctive relief is granted by any court, suspending temporarily or permanently the implementation of this Agreement, then the Parties agree that all Project Work that would otherwise be covered by this Agreement should be continued to be bid and constructed without application of this Agreement so that there is no delay or interference with the ongoing planning, bidding and construction of any Project Work.

Section 18.2 Effect of Injunctions or Other Court Orders: The Parties recognize the right of the District to withdraw, at its absolute discretion, the utilization of the Agreement as part of any bid specification should a Court of competent jurisdiction issue any order, or any applicable statute which could result, temporarily or permanently in delay of the bidding, awarding and/or construction on the Project. Notwithstanding such an action by the District, or such court order or statutory provision, the Parties agree that the Agreement shall remain in full force and the fact on covered Project Work to the maximum extent legally possible.

## **ARTICLE 19 WAIVER**

A waiver of or a failure to assert any provisions of this Agreement by any or all of the Parties hereto shall not constitute a waiver of such provision for the future. Any such waiver shall not constitute a modification of the Agreement or change in the terms and conditions of the Agreement and shall not relieve, excuse or release any of the Parties from any of their rights, duties or obligations hereunder.

## **ARTICLE 20 AMENDMENTS**

The provisions of this Agreement can be renegotiated, supplemented, rescinded or otherwise altered only by mutual agreement in writing, hereafter signed by the negotiating Parties hereto.

## **ARTICLE 21 DURATION OF THE AGREEMENT**

### **Section 21.1 Duration:**

21.1.1 This Agreement shall be effective from the date signed by all Parties and shall remain in effect for a period of five (5) years and shall continue in effect from year to year thereafter unless either Party provides written notice of its intent to terminate, sent no earlier later than sixty (60) days prior to the termination date or successor termination date. Any Covered Project awarded during the term of this Agreement shall continue to be covered hereunder, until completion of the Project, notwithstanding the expiration date of this Agreement.

21.1.2 This Agreement may be extended by mutual consent of the District and the Unions for such further periods as the Parties shall agree to.

### **Section 21.2 Turnover and Final Acceptance of Completed Work:**

21.2.1 Construction of any phase, portion, section, or segment of Project Work shall be deemed complete when such phase, portion, section or segment has been turned over to the District by the Contractor and the District has accepted such phase, portion, section, or segment. As areas and systems of the Project are inspected and construction-tested and/or approved and accepted by the District or third parties with the approval of the District, the Agreement shall have no further force or effect on such items or areas, except when the Contractor is directed by the District to engage and repairs or modifications required by its contract(s) with the District.

21.2.2 Notice of each final acceptance received by the Contractor will be provided to the Council with the description of what portion, segment, etc. has been accepted. Final acceptance may be subject to a “punch” list, and in such case, the Agreement will continue to apply to each such item on the list until it is completed to the satisfaction of the District and Notice of Acceptance is given by the District or its representative to the Contractor. At the request of the Union, complete information describing any “punch” list work, as well as any additional work required of a Contractor at the direction of the District pursuant to (a) above, involving otherwise turned-over and completed facilities which have been accepted by the District, will be available from the Community Workforce Coordinator.



IN WITNESS whereof the Parties have caused this Continuity of Work Agreement to be executed as of the date and year above stated.

ANTELOPE VALLEY UNION  
HIGH SCHOOL DISTRICT

LOS COUNTIES ANGELES/ORANGE  
BUILDING & CONSTRUCTION  
TRADES COUNCIL

By: \_\_\_\_\_

By: \_\_\_\_\_

Chris Hannan, Executive  
Secretary

Dated: \_\_\_\_\_

Dated: \_\_\_\_\_

LOS ANGELES/ORANGE COUNTIES BUILDING AND CONSTRUCTION  
TRADES COUNCIL CRAFT UNIONS AND DISTRICT COUNCILS

- Asbestos Heat & Frost Insulators (Local 5) \_\_\_\_\_
- Boilermakers (Local 92) \_\_\_\_\_
- Bricklayers & Allied Craftworkers (Local 4) \_\_\_\_\_
- Cement Masons (Local 600) \_\_\_\_\_
- Electricians (Local 11) \_\_\_\_\_
- Elevator Constructors (Local 18) \_\_\_\_\_
- Gunite Workers (Local 345) \_\_\_\_\_
- Iron Workers (Reinforced – Local 416) \_\_\_\_\_
- Iron Workers (Structural – Local 433) \_\_\_\_\_
- District Council of Laborers \_\_\_\_\_
- Laborers (Local 300) \_\_\_\_\_
- Operating Engineers (Local 12) \_\_\_\_\_
- Operating Engineers (Local 12) \_\_\_\_\_
- Operating Engineers (Local 12) \_\_\_\_\_
- Painters & Allied Trades DC 36 \_\_\_\_\_
- Pipe Trades (Local 250) \_\_\_\_\_
- Pipe Trades (Local 345) \_\_\_\_\_
- Pipe Trades (Plumbers Local 761) \_\_\_\_\_
- Pipe Trades (Sprinkler Fitters Local 669) \_\_\_\_\_
- Pipe Trades (Sprinkler Fitters Local 709) \_\_\_\_\_
- Plasterers (Local 200) \_\_\_\_\_
- Plaster Tenders (Local 1414) \_\_\_\_\_
- Roofers & Waterproofers (Local 36) \_\_\_\_\_
- Sheet Metal Workers (Local 105) \_\_\_\_\_
- Teamsters (Local 986) \_\_\_\_\_
- Southwest Mountain States \_\_\_\_\_
- Regional Council of Carpenters \_\_\_\_\_

**ATTACHMENT B**  
Local Resident Zip Codes

**DISTRICT SERVICE AREA ZIP CODES**  
**(Tier 1)**

91390  
93501  
93510  
93523  
93532  
93534  
93535  
93536  
93539  
93543  
93550  
93551  
93552  
93554  
93560  
93584  
93586  
93590  
93591  
93599

**(Tier 2)**

**THE REMAINING AREA ZIP CODES IN LOS ANGELES COUNTY AND THE  
GREATER ANTELOPE VALLEY**

**ATTACHMENT C**

**ANTELOPE VALLEY UNION HIGH SCHOOL DISTRICT  
CRAFT REQUEST FORM**

**TO THE CONTRACTOR:** Please complete and fax this form to the applicable union to request craft workers that fulfill the hiring requirements for this project. After faxing your request, please call the Union to verify receipt and substantiate their capacity to furnish workers as specified below. Please print your Fax Transmission Verification Reports and keep copies for your records.

The ANTELOPE VALLEY UNION HIGH SCHOOL DISTRICT Community Workforce Agreement establishes a goal that 30% of all of the labor and craft positions shall be from qualified workers: first, Area Residents residing in those first tier zip codes which cover the District service area, as reflected on the attached list of zip codes on Attachment B, as well as Veterans and students which have graduated from the MC3 program or the District, regardless of where they reside, second, qualified workers residing in the remainder of the Los Angeles County and Greater Antelope Valley. For Dispatch purposes, employees residing within any of these three (3) areas, as well as Veterans and students which have graduated from the District, regardless of where they reside, shall be referred to as Local Residents.

**TO THE UNION:** Please complete the “Union Use Only” section on the next page and fax this form back to the requesting Contractor. Be sure to retain a copy of this form for your records.

**CONTRACTOR USE ONLY**

**To:** Union Local # \_\_\_\_\_ **Fax#** ( ) \_\_\_\_\_ **Date:** \_\_\_\_\_  
**Cc:** **Community Workforce** Coordinator  
**From:** Company: \_\_\_\_\_ **Issued By:** \_\_\_\_\_  
 Contact Phone: ( ) \_\_\_\_\_ **Contact Fax:** ( ) \_\_\_\_\_

**PLEASE PROVIDE ME WITH THE FOLLOWING UNION CRAFT WORKERS.**

Craft Classification (i.e., plumber, painter, etc.)	Journeyman or Apprentice	Local Resident or General Dispatch	Number of workers needed	Report Date	Report Time
<b>TOTAL WORKERS REQUESTED =</b> _____					

Please have worker(s) report to the following work address indicated below:

**Project Name:** \_\_\_\_\_ **Site:** \_\_\_\_\_ **Address:** \_\_\_\_\_

**Report to:** \_\_\_\_\_ **On-site Tel:** \_\_\_\_\_ **On-site Fax:** \_\_\_\_\_

**Comment or Special Instructions:** \_\_\_\_\_

**UNION USE ONLY**

Date dispatch request received:
Dispatch received by:
Classification of worker requested:
Classification of worker dispatched:

**WORKER REFERRED**

Name:		
Date worker was dispatched:		
Is the worker referred a:		(check all that apply)
JOURNEYMAN	Yes _____	No _____
APPRENTICE	Yes _____	No _____
LOCAL RESIDENT	Yes _____	No _____
GENERAL DISPATCH FROM OUT OF WORK LIST	Yes _____	No _____

[This form is not intended to replace a Union's Dispatch or Referral Form normally given to the employee when being dispatched to the jobsite.]

## ATTACHMENT D

### LOS ANGELES/ORANGE COUNTIES BUILDING AND CONSTRUCTION TRADES COUNCIL APPROVED DRUG AND ALCOHOL TESTING POLICY

The Parties recognize the problems that drug and alcohol abuse have created in the construction industry and the need to develop drug and alcohol abuse prevention programs. Accordingly, the Parties agree that in order to enhance the safety of the workplace and to maintain a drug and alcohol-free work environment, individual Contractors shall require applicants or employees to undergo drug and alcohol testing in accordance with this CWA and this policy, Attachment C – Drug and Alcohol Testing Policy, hereafter “Policy.”

1. It is understood that the use, possession, transfer, or sale of illegal drugs, narcotics, or other unlawful substances, as well as being under the influence of alcohol and the possession of or consuming alcohol is absolutely prohibited while employees are on the Contractor’s job premises or while working on any jobsite in connection with work performed under the CWA.
2. No Contractor may implement a drug and alcohol testing program that does not conform in all respects to the provisions of this Policy.
3. No Contractor may implement drug and alcohol testing at any jobsite unless written notice is given to the Union setting forth the location of the jobsite, a description of the project under construction, and the name and telephone number of the Prime Contractor's project manager. Said notice shall be provided at the pre-job conferences for each Covered Project. Failure to give such notice shall make any drug and alcohol testing engaged in by the Contractor a violation of the CWA and subject to the Article 10 grievance procedure.
4. A Contractor who elects to implement drug and alcohol testing pursuant to this Policy shall require all craft employees on the Covered Project to be tested. With respect to individuals who become employed on the Covered Project subsequent to the proper implementation of a valid drug and alcohol testing program, such test shall be administered upon the commencement of employment on the project, whether by referral from a Union Dispatch Office, transfer from another project, or another method. Individuals who were employed on the project prior to proper implementation of a valid drug and alcohol testing program may only be subjected to testing for the reasons set forth in paragraphs 5(g)(1) through 5(g)(3) and paragraphs 6(a) through 6(e) of this Policy. Refusal to undergo such testing shall be considered sufficient grounds to deny employment on the project.
5. The following procedure shall apply to all drug and alcohol testing:

- a. The Contractor may request urine samples only. The applicant or employee shall not be observed when the urine specimen is given. An applicant or employee, at his or her sole option, shall, upon request, receive a blood test in lieu of a urine test. No employee of the Contractor shall draw blood from a bargaining unit employee, touch or handle urine specimens, or in any way become involved in the chain of custody of urine or blood specimens. A Union Business Representative, subject to the approval of the individual applicant or employee, shall be permitted to accompany the applicant or employee to the collection facility to observe the collection, bottling, and sealing of the specimen.
- b. A Contractor may request an applicant or employee promptly, within four (4) hours of the Contractor's request, perform an alcohol breathalyzer test at a certified laboratory only, and cutoff levels shall be those mandated by applicable state or federal law.
- c. The testing shall be done by a laboratory approved by the Substance Abuse & Mental Health Services Administration (SAMHSA), which is chosen by the Contractor and the Union.
- d. An initial test shall be performed using the Enzyme Multiplied Immunoassay Technique (EMIT). In the event a question or positive result arises from the initial test, a confirmation test must be utilized before action can be taken against the applicant or employee. The confirmation test will be by Gas Chromatography/Mass Spectrometry (GC/MS). Cutoff levels for both the initial test and confirmation test will be those established by SAMHSA and this Policy. Should these SAMHSA levels be changed during the course of the CWA or new testing procedures are approved, then these new regulations will be deemed as part of this existing CWA. Confirmed positive samples will be retained by the testing laboratory in secured long-term frozen storage for a minimum of one (1) year. Handling and transportation of each sample must be documented through strict chain-of-custody procedures.
- e. In the event of a confirmed positive test result, the applicant or employee may request, within forty-eight (48) hours, a sample of his/her specimen from the testing laboratory for purposes of a second test to be performed at a second laboratory, designated by the Union and approved by SAMHSA. The retest must be performed within ten (10) days of the request. Chain of custody for this sample shall be maintained by the Contractor between the original testing laboratory and the Union's designated laboratory. Retesting shall be performed at the applicant's or employee's expense. In the event of conflicting test results, the Contractor may require a third test, at the Contractor's expense.
- f. If, as a result of the above testing procedure, it is determined that an applicant or employee has tested positive, this shall be considered sufficient grounds to deny the applicant or employee his/her employment on the project.
- g. No individual who tests negative for drugs and alcohol pursuant to the above procedure and becomes employed on the project shall again be subjected to drug and alcohol testing with the following exceptions:

- 1) Employees who are involved in industrial accidents resulting in damage to plant, property, or equipment or injury to him/her or others may be tested for drugs or alcohol pursuant to the procedures stated hereinabove.
  - 2) The Contractor may test employees following thirty (30) days' advance written notice to the employee(s) to be tested and to the applicable Union. Notice to the applicable Union shall be sent by certified mail to the affected Union with a copy to the Project Labor Coordinator. Such testing shall be pursuant to the procedures stated hereinabove.
  - 3) The Contractor may test an employee where the Contractor has reasonable cause to believe that the employee is impaired from performing his/her job. Reasonable cause shall be defined as being aberrant or unusual behavior, the type of which is a recognized and accepted symptom of impairment (e.g., slurred speech, unusual lack of muscular coordination). Such behavior must be actually observed by at least two (2) persons, one (1) of whom shall be a supervisor who has been trained to recognize the symptoms of drug and alcohol abuse or impairment and the other of whom shall be the Job Steward. If the Job Steward is unavailable or there is no Job Steward on the Covered Project, the other person shall be a member of the applicable Union's bargaining unit. Testing shall be pursuant to the procedures stated hereinabove. Employees who are tested pursuant to the exceptions set forth in this paragraph and who test positive will be removed from the Contractor's payroll.
- h. Applicants or employees who do not test positive shall be paid for all time lost while undergoing drug and alcohol testing. Payment shall be at the applicable wage and benefit rates set forth in the Applicable Prevailing Wage Laws. Applicants who have been dispatched from the Union and who are not put to work pending the results of a test will be paid waiting time until such time as they are put to work. It is understood that an applicant must pass the test as a condition of employment. Applicants who are put to work pending the results of a test will be considered probationary employees.
6. The Contractors will be allowed to conduct periodic jobsite drug and alcohol testing on the Project under the following conditions:
    - a. The entire jobsite must be tested, including any employee or subcontractor's employee who worked on that project three (3) working days before or after the date of the test;
    - b. Jobsite testing cannot commence sooner than fifteen (15) days after start of the work on the project;
    - c. Prior to start of periodic testing, a Business Representative will be allowed to conduct an educational period on company time to explain periodic jobsite testing program to affected employees;
    - d. Testing shall be conducted by an SAMHSA-certified laboratory, pursuant to the provisions set forth in paragraph 5 hereinabove.



- e. Only two (2) periodic tests may be performed in a twelve (12)-month period.
7. It is understood that the unsafe use of prescribed medication, or where the use of prescribed medication impairs the employee's ability to perform work, is a basis for the Contractor to remove the employee from the jobsite.
  8. Any grievance or dispute that may arise out of the application of this Policy shall be subject to the grievance and arbitration procedures set forth in the CWA.
  9. The establishment or operation of this Policy shall not curtail any right of any employee found in any law, rule, or regulation. Should any part of this Policy be found unlawful by a court of competent jurisdiction or a public agency having jurisdiction over the Parties, the remaining portions of the CWA shall be unaffected, and the Parties shall enter negotiations to replace the affected provision.
  10. Present employees, if tested positive, shall have the prerogative for rehabilitation program at the employee's expense. When such program has been successfully completed, the Contractor shall not discriminate in any way against the employee. If work for which the employee is qualified exists, he/she may be reinstated.
  11. The Contractor agrees that results of urine and blood tests performed hereunder will be considered medical records held confidential to the extent permitted or required by law. Such records shall not be released to any persons or entities other than designated Contractor representatives and the applicable Union. Such release to the applicable Union shall only be allowed upon the signing of a written release by the employee, and the information contained therein shall not be used to discourage the employment of the individual applicant or employee on any subsequent occasion.
  12. Employees who seek voluntary assistance for substance abuse may not be disciplined for seeking such assistance. Requests from employees for such assistance shall remain confidential and shall not be revealed to other employees or management personnel without the employee's consent. Employees enrolled in substance abuse programs will be subject to all Contractor rules, regulations, and job performance standards with the understanding that an employee enrolled in such a program is receiving treatment for an illness.
  13. The Contractor shall indemnify and hold the Union harmless against any and all claims, demands, suits, or liabilities that may arise out of the application of this Policy.
  14. This Policy shall constitute the only Policy in effect between the Parties concerning drug and alcohol abuse, prevention, and testing. Any modifications thereto must be accomplished pursuant to collective bargaining negotiations between the Parties.

## SPECIMEN REPORTING CRITERIA

Initial Test Analyte	Initial Test Cutoff <sup>1</sup>	Confirmatory Test Analyte	Confirmatory Test Cutoff Concentration
Marijuana metabolites (THCA) <sup>2</sup>	50 ng/ml <sup>3</sup>	THCA	15 ng/ml
Cocaine metabolite (Benzoylecgonine)	150 ng/ml <sup>3</sup>	Benzoylecgonine	100 ng/ml
Codeine/ Morphine	2000 ng/ml	Codeine Morphine	2000 ng/ml 2000 ng/ml
Hydrocodone/ Hydromorphone	300 ng/ml	Hydrocodone Hydromorphone	100 ng/ml 100 ng/ml
Alcohol	0.02%	Ethanol	0.02%
Oxycodone/ Oxymorphone	100 ng/ml	Oxycodone Oxymorphone	100 ng/ml 100 ng/ml
6-Acetylmorphine	10 ng/ml	6-Acetylmorphine	10 ng/ml
Phencyclidine	25 ng/ml	Phencyclidine	25 ng/ml
Amphetamine/ Methamphetamine	500 ng/ml	Amphetamine Methamphetamine	250 ng/ml 250 ng/ml
MDMA <sup>4</sup> /MDA <sup>5</sup>	500 ng/ml	MDMA MDA	250 ng/ml 250 ng/ml
Initial Test Analyte	Initial Test Cutoff	Confirmatory Test Analyte	Confirmatory Test Cutoff Concentration
Barbiturates	300 ng/ml	Barbiturates	200 ng/ml
Benzodiazepines	300 ng/ml	Benzodiazepines	300 ng/ml
Methadone <sup>6</sup>	300 ng/ml	Methadone	100 ng/ml
Methaqualone	300 ng/ml	Methaqualone	300 ng/ml
Propoxyphene	300 ng/ml	Propoxyphene	100 ng/ml

<sup>1</sup> For grouped analytes (i.e., two or more analytes that are in the same drug class and have the same initial test cutoff):

**Immunoassay:** The test must be calibrated with one analyte from the group identified as the target analyte. The cross-reactivity of the immunoassay to the other analyte(s) within the group must be 80 percent or greater; if not, separate immunoassays must be used for the analytes within the group.

**Alternate technology:** Either one analyte or all analytes from the group must be used for calibration, depending on the technology. At least one analyte within the group must have a concentration equal to or greater than the initial test cutoff or, alternatively, the sum of the analytes present (i.e., equal to or greater than the laboratory's validated limit of quantification) must be equal to or greater than the initial test cutoff.

<sup>2</sup> An immunoassay must be calibrated with the target analyte, 9-tetrahydrocannabinol-9- carboxylic acid (THCA).

<sup>3</sup> **Alternate technology (THCA and benzoylecgonine):** The confirmatory test cutoff must be used for an alternate technology initial test that is specific for the target analyte (i.e., 15 ng/ml for THCA, 100 ng/ml for benzoylecgonine).

<sup>4</sup> Methylenedioxyamphetamine (MDMA)

<sup>5</sup> Methylenedioxyamphetamine (MDA)

<sup>6</sup> Employees with a prescription for methadone who are using the medication as prescribed, and are not impaired and can safely perform their work, will not be considered to have violated this Policy.

MEMORANDUM OF UNDERSTANDING REGARDING  
**“QUICK” DRUG SCREENING TESTS PURSUANT TO  
ATTACHMENT C – DRUG AND ALCOHOL TESTING POLICY**

It is hereby agreed between the Parties hereto that a Contractor who has otherwise properly implemented drug and alcohol testing, as set forth in the Policy, shall have the right to offer an applicant or employee a "quick" drug screening test. This “quick” screen test shall consist either of the “ICUP” urine screen or similar test or an oral screen test. The applicant or employee shall have the absolute right to select either of the two “quick” screen tests, or to reject both and request a full drug test.

An applicant or employee who selects one of the "quick" screen tests, and who passes the test, shall be put to work immediately. An applicant or employee who fails the "quick" screen test, or who rejects the "quick" screen tests, shall be tested pursuant to the procedures set forth in the Policy. The sample used for the "quick" screen test shall be discarded immediately upon conclusion of the test. An applicant or employee shall not be deprived of any rights granted to them by the Policy as a result of any occurrence related to the “quick” screen test.