

# Understanding Basic Fire Codes

- Discontinue blocking emergency windows which are required as secondary exits in portable classrooms. (CFC1010.1.4.4.1)

Think of the window furthest from the main door as a second door. Window needs to have direct access to the outside. If window has 2 openings, at least one opening needs to have direct access.



**NO**



**YES**

- Remove and maintain storage 18" below ceiling for sprinklered buildings and 24" for non-sprinklered areas. (CFC 315.3.1)

Rule of thumb: Don't put anything on the top shelf.



**NO**



**YES**

- Provide a minimum of 30" width, 36" depth, 78" high clearance to all electrical panels (CFC605.3)

Nothing blocking direct access to electrical panels. This is to allow maintenance workers and fire personnel to easily access the panels.



**NO**

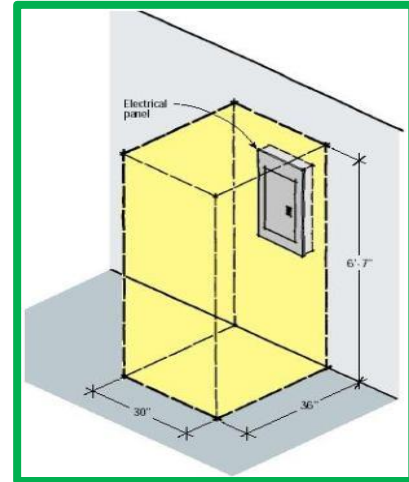

**YES**

- Post signs indicating location of extinguisher when not readily visible or relocate

You must have direct access to your fire extinguisher. It needs to be easily visible and readily available at all times. If not, it must be relocated or a sign needs to be provided.



**NO**



**YES**

- Decorative materials shall not exceed 50% of the specific wall or ceiling area to which such materials are attached. (CFC807.5.2.3)

Each wall in a room is counted individually. Decorative materials cannot exceed more than 50% of each wall. Chalk boards, white boards, projection screens, etc. count as covered wall space



NO



NO



NO





YES

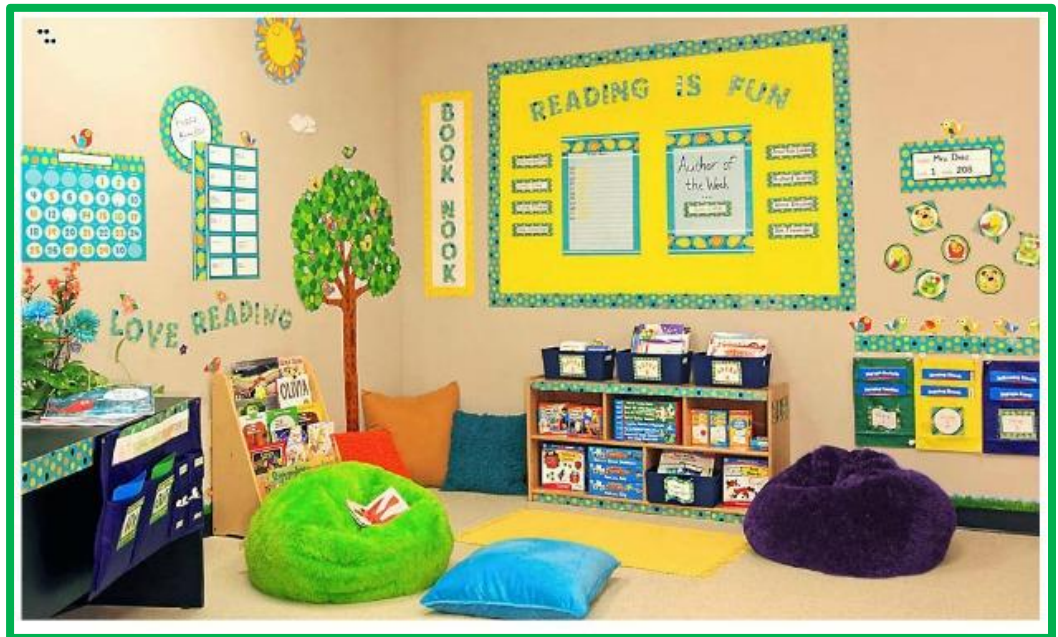

YES