

ARCHITECTURE

T M P ARCHITECTURE I N C
1191 WEST SQUARE LAKE ROAD · BLOOMFIELD HILLS · MICHIGAN · 48302
PH · 248.338.4561 FX · 248.338.0223 EM · INFO @TMP-ARCHITECTURE.COM



PROFESSIONAL ENGINEERING ASSOCIATES
2430 Rochester Ct, Suite 100
Troy, MI 48063-1972
Phone: (248) 689-9050
Fax: (248) 689-1044
website: www.peainc.com



350 East Michigan Avenue Suite #415
Kalamazoo Michigan 49007
Phone (269) 381-3357
Fax (269) 381-2944

MORSE ELEMENTARY SCHOOL PLAYGROUND TROY SCHOOL DISTRICT - TROY, MICHIGAN

2022 BOND PROGRAM - BID PACKAGE NO 01A PROJECT NUMBER 22093B CONSTRUCTION DOCUMENTS

CONSULTANTS:

CIVIL ENGINEER

**PEA GROUP
CONSULTING ENGINEERS**
1849 POND RUN
AUBURN HILLS, MICHIGAN 48326
PHONE: (248) 689-9050

PLAYGROUND CONSULTANT

**OCBA LANDSCAPE ARCHITECTS
CONSULTING ENGINEERS**
124 FULTON STREET E, SUITE 68
GRAND RAPIDS, MICHIGAN 49503
PHONE: (269) 381-3357

LIST OF DRAWINGS

GENERAL INFORMATION

TS.1 COVER SHEET
TG.1 GENERAL INFORMATION

CIVIL

C2.0 OVERALL PLAYGROUND LAYOUT PLAN
C2.1 PLAYGROUND LAYOUT ENLARGEMENT PLANS
C2.2 PLAYGROUND LAYOUT ENLARGEMENT PLAN
C3.0 OVERALL PLAYGROUND GRADING PLAN & ENLARGEMENT PLAN PRE-K & KINDERGARTEN
C3.1 PLAYGROUND GRADING PLAN ENLARGEMENTS - 1ST-2ND GRADE
C3.2 PLAYGROUND GRADING PLAN ENLARGEMENTS - 3RD-5TH GRADE
C4.0 DETAILS

CIVIL

CE-5.1.0 TOPOGRAPHIC SURVEY
CE-5.2.0 DEMOLITION PLAN
CE-5.3.0 DIMENSION & PAVING PLAN
CE-5.4.0 GRADING, UTILITY, & SOIL EROSION CONTROL PLAN
CE-5.5.0 NOTES & DETAILS

STANDARD SOIL EROSION CONTROL DETAILS
STANDARD STORM SEWER DETAILS

LANDSCAPE

L1.0 OVERALL LANDSCAPE PLAN

PROJECT DATA:

LOCATION MAP

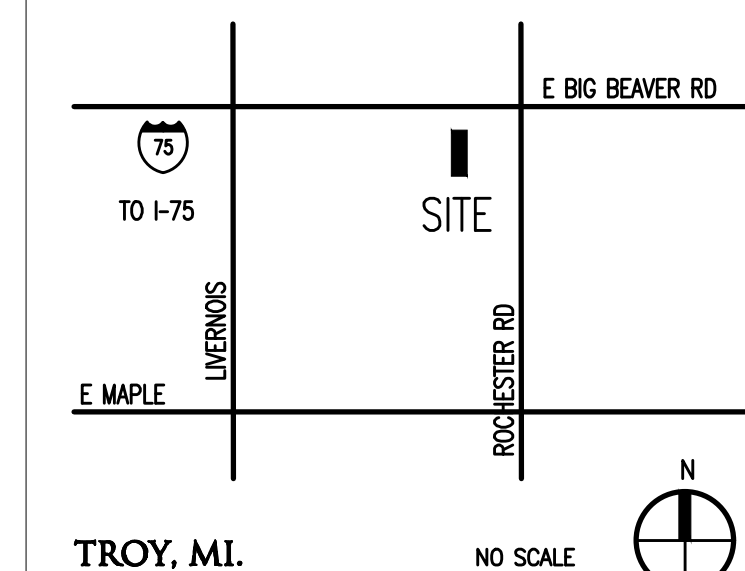

TROY, MI.

BUILDING:

BUILDING AREA(S) = NOT APPLICABLE

CODE:

GOVERNING CODES:

- 2016 SCHOOL FIRE SAFETY RULES (2012 Life Safety Code, plus amendments)
 - 2015 MICHIGAN BUILDING CODE
 - 2015 MICHIGAN REHABILITATION CODE FOR EXISTING BUILDINGS
 - 2018 MICHIGAN PLUMBING CODE
 - 2015 MICHIGAN MECHANICAL CODE
 - 2015 MICHIGAN UNIFORM ENERGY CODE (ANSI/ASHRAE/IES Standard 90.1-2013)
 - 2017 MICHIGAN ELECTRICAL CODE (2017 NEC, plus Part 8 Rules)
 - 2010 MICHIGAN ELEVATOR RULES (ASME A17.1-2010, ASME A18.1-2011)
 - MICHIGAN BARRIER FREE CODE (Michigan Building Code 2015 and ICC A117.1-2009)
 - 2013 MICHIGAN BOILER CODE RULES (ASME Boiler and Pressure Vessel Code, 2019 edition) (National Board Inspection Code [NBIC], 2019 edition)
- CONSTRUCTION CLASSIFICATION: II-B(MBC)/11(000)NFPA
USE GROUP CLASSIFICATION: E-EDUCATION

ADDRESS: MORSE ELEMENTARY SCHOOL
475 CHERRY
TROY, MI 48083

LICENSEE'S STATEMENT:

This Document has been prepared under the supervision of the Architect, as the person in Responsible Charge with the firm of TMP ARCHITECTURE, INC. An original embossed or rubber stamp seal and original signature of the Architect is required and shall be affixed to any copy of this Document submitted to a governmental agency for approval or record. This is in conformance with the State of Michigan's PA 299, Article 20 and the General Rules of the Board of Architects.

The Architect's seal provided hereon does not take responsibility for certain portions of the Documentation or project requiring the services of a licensed Professional Engineer or other design professional. An original embossed or rubber stamp seal and original signature of the Professional Engineer is required and shall be affixed to any copy of this or other Document submitted to a governmental agency for approval or record. The engineering firms associated with this document are listed above as Consultants.

REGISTRATION SEALS

COPYRIGHT

© The "architectural work" displayed on these documents is owned exclusively by TMP Architecture, Inc. and may not be used for any purpose without their involvement or express written consent.

PROJECT TITLE

**Morse
Elementary School**
PROJECT NO.
22093B

DRAWING NO.

TS.1

11-09-2023 CONSTRUCTION DOCUMENTS
DATE ISSUED FOR:



TMP ARCHITECTURE INC
1291 WEST SQUARE LAKE ROAD
BLOOMFIELD HILLS MICHIGAN 48302
PH 248.338.4561 FX 248.338.0223
EM INFO TMP-ARCHITECTURE.COM

REGISTRATION SEAL

CONSULTANT



141 E. Michigan Avenue, Suite 500
Kalamazoo Michigan 49007
Phone (269) 381-3357
Fax (269) 381-2944

PROJECT TITLE

Morse Elementary School Playground Renovation Bid Package No.01A

Troy School District
Troy, Michigan

DRAWING TITLE
Playground Layout
Enlargement Plan

ISSUE DATES

DATE ISSUED FOR:

DRAWN	...
CHECKED	...
APPROVED	...

PROJECT NO.

22093B

DRAWING NO.

C2.2

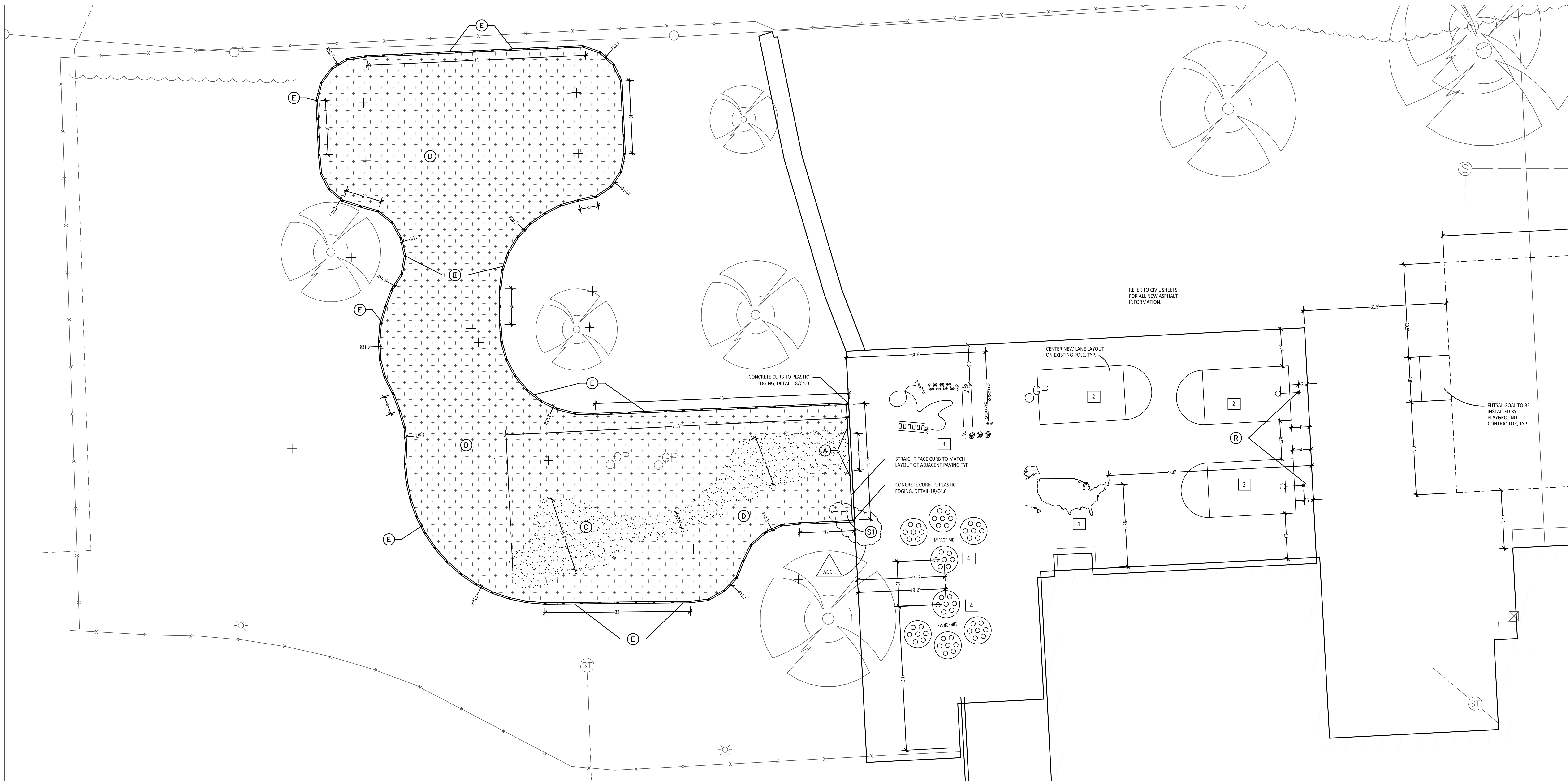

1 Playground Layout Enlargement Plan - Lower Elementary and Paved Play

Scale: 1"=10'-0"

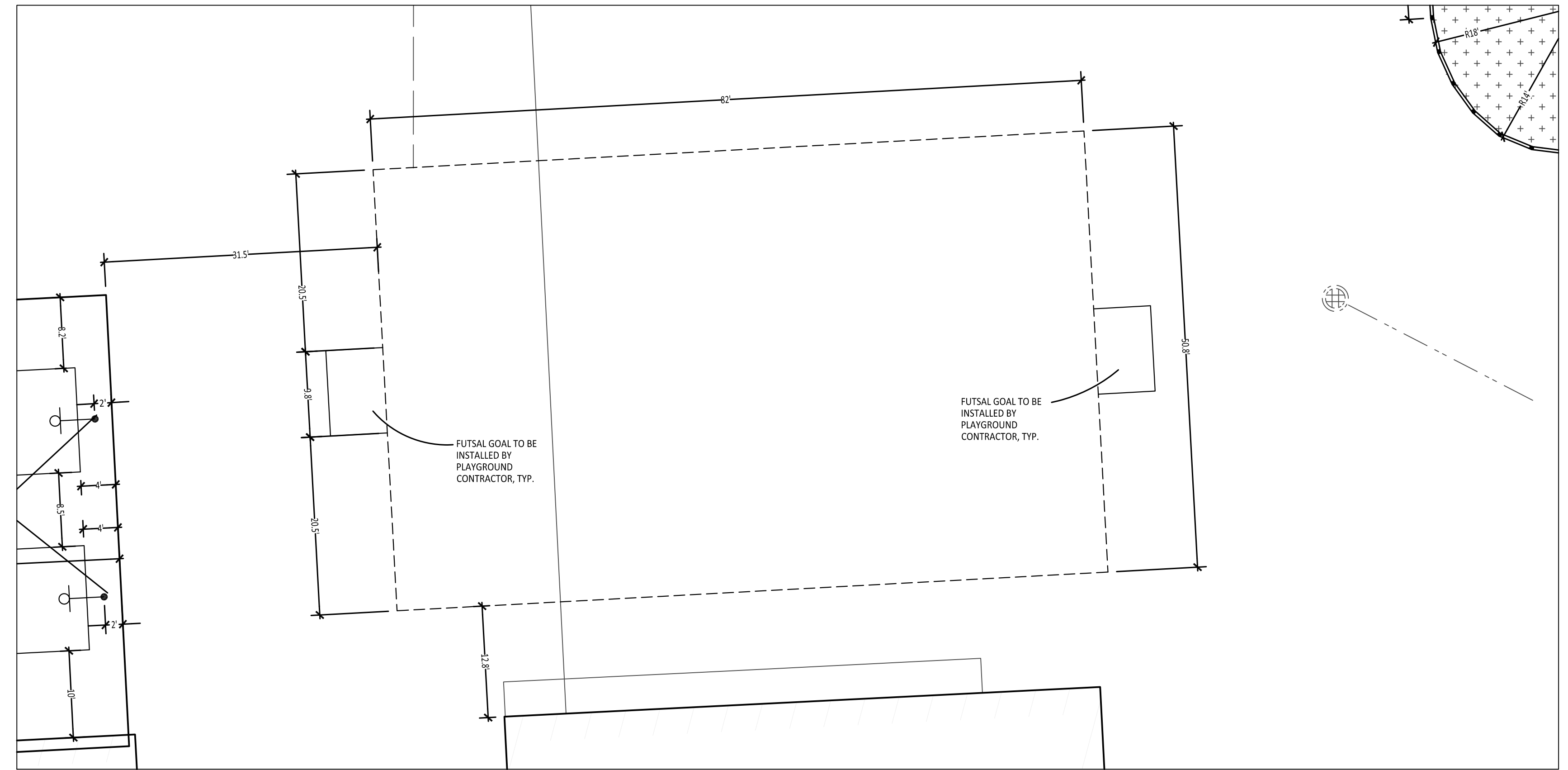
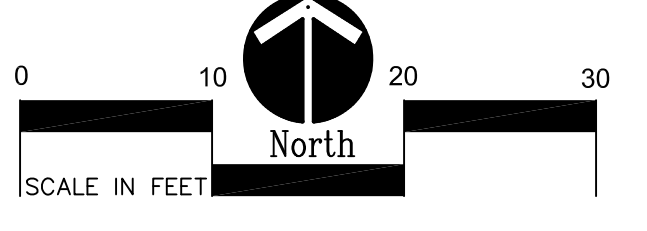

2 Playground Layout Enlargement Plan - Futsal Field

Scale: 1"=10'-0"

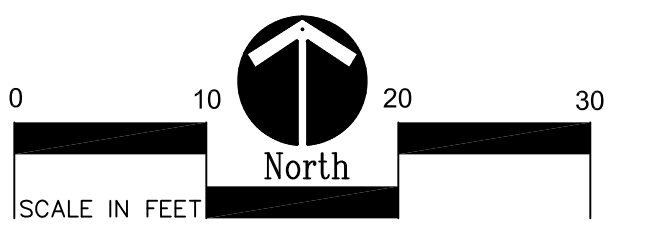

LAYOUT NOTES:

- EXISTING CONDITIONS SURVEY PROVIDED BY PEA GROUP, 1849 POND RUN, AUBURN HILLS, MICHIGAN, 48326, (248)689-9090.
- PROTECT ALL TREES AND EXISTING FEATURES TO REMAIN AS SPECIFIED.
- PAVEMENT DIMENSIONS AND RADI ARE TO EDGE OF PAVEMENT OR BACK OF CURB. PLASTIC EDGING DIMENSIONS AND RADI ARE TO CENTER OF EDGE SEGMENT.
- ALL NEW PAVEMENTS AND WALKS TO MEET 2010 ADA STANDARDS FOR ACCESSIBLE DESIGN.
- ALL EXISTING PLAYGROUND EQUIPMENT TO BE REMOVED **MUST BE DESTROYED COMPLETELY** SO THAT IT CANNOT BE RE-ASSEMBLED. THE CONTRACTOR IS NOT ALLOWED TO RE-USE, DONATE, OR SELL ANY EXISTING PLAYGROUND EQUIPMENT SCHEDULED TO BE DEMOLISHED.
- THE PURCHASE AND INSTALLATION OF ALL PLAYGROUND EQUIPMENT, PLAY SAFETY SURFACING, AND PLAY SAFETY SURFACING EDGING IN UNDER A SEPARATE CONTRACT AND IS NOT INCLUDED IN THIS BID PACKAGE. SITE CONTRACTORS ARE REQUIRED TO COORDINATE INSTALLATION OF PLAYGROUND EQUIPMENT, PLAY SAFETY SURFACING, AND PLAY SAFETY SURFACING EDGING WITH PLAYGROUND CONTRACTOR PRIOR TO ANY EXCAVATION OR PAVING INSTALLATION.

1ST - 5TH GRADE PAINTED GAMES SCHEDULE:

SYMBOL	DESCRIPTION	DETAIL
1	MAP OF UNITED STATES	SEE SPECS, 3/C2.0
2	BASKETBALL LANE LAYOUT	2 / C2.0
3	SILLY TRACK	4 / C2.0
4	MIRROR ME	5 / C2.0
5	N/A	XX / CXXX

BARRIER-FREE NOTES

- BARRIER-FREE PARKING AND ACCESSIBLE ROUTE(S) MUST COMPLY WITH THE AMERICANS WITH DISABILITIES ACT AND MICHIGAN BARRIER-FREE CODE REQUIREMENTS, INCLUDING BUT NOT LIMITED TO THE FOLLOWING:
- 1.50 (2%) MAXIMUM CROSS-SLOPE ON ACCESSIBLE ROUTE.
 - NO CHANGES IN LEVEL GREATER THAN 1/2" ALONG ACCESSIBLE ROUTE.
 - 1.20 (5%) MAXIMUM LONGITUDINAL SLOPE ON ACCESSIBLE ROUTE (EXCEPT WHERE RAMP AS PROVIDED).
 - 1.50 (2%) MAXIMUM SLOPE (IN ANY DIRECTION) IN B.F. PARKING AND ACCESS AISLES.

NOTE: VERIFY LOCATION OF NEW PLAYGROUND EQUIPMENT PRIOR TO INSTALLATION OF ANY CONCRETE CURB. CONCRETE CURB TO BE INSTALLED OUTSIDE OF FALL SAFETY ZONE OF EACH PIECE OF EQUIPMENT PER ASTM 1487-05 AND MANUFACTURER'S WRITTEN RECOMMENDATIONS.

NOTE: PLAYGROUND EQUIPMENT AND SURFACING PURCHASE AND INSTALLATION IS UNDER SEPARATE CONTRACT AND IS NOT INCLUDED IN THIS BID PACKAGE. CONTRACTOR IS REQUIRED TO COORDINATE INSTALLATION OF PLAYGROUND EQUIPMENT AND SURFACING WITH PLAYGROUND INSTALLER PRIOR TO ANY EXCAVATION AND CONCRETE CURBING OR PAVING INSTALLATION.

PROPOSED FEATURES LEGEND:

SYMBOL	DESCRIPTION	KEY	DESCRIPTION	DETAIL
[Symbol A]	STRAIGHT FACE CONCRETE CURB	A	STRAIGHT FACE CONCRETE CURB	6 / C4.0
[Symbol B]	THICKENED EDGE CONCRETE	B	THICKENED EDGE CONCRETE	11 / C4.0
[Symbol C]	RESILIENT SURFACING (BY OTHERS)	C	RESILIENT SURFACING (BY OTHERS)	7 / C4.0
[Symbol D]	LOOSE FILL SAFETY SURFACING (BY OTHERS)	D	LOOSE FILL SAFETY SURFACING (BY OTHERS)	3 & 9 / C4.0
[Symbol E]	PLASTIC PLAY EDGING (BY OTHERS)	E	PLASTIC PLAY EDGING (BY OTHERS)	12, 13, & 18 / C4.0
[Symbol F]	N/A	F	N/A	
[Symbol G]	CONCRETE WALK	G	CONCRETE WALK	2 / C4.0
[Symbol H]	PLAY AREA ENTRANCE RAMP	H	PLAY AREA ENTRANCE RAMP	16 / C4.0
[Symbol I]	N/A	I	N/A	
[Symbol J]	N/A	J	N/A	
[Symbol K]	BASKETBALL HOOP POLE (BY OTHERS)	K	BASKETBALL HOOP POLE (BY OTHERS)	17 / C4.0
[Symbol L]	N/A	L	N/A	
[Symbol M]	N/A	M	N/A	
[Symbol N]	BITUMINOUS SEALCOATING	N	BITUMINOUS SEALCOATING	SEE SPECS
[Symbol P]	N/A	P	N/A	

SYMBOL	DESCRIPTION	DETAIL
[Symbol S1]	COMMUNICATION BOARD	10 / C4.0

--- LIMIT OF WORK
--- ENLARGEMENT LIMIT LINE

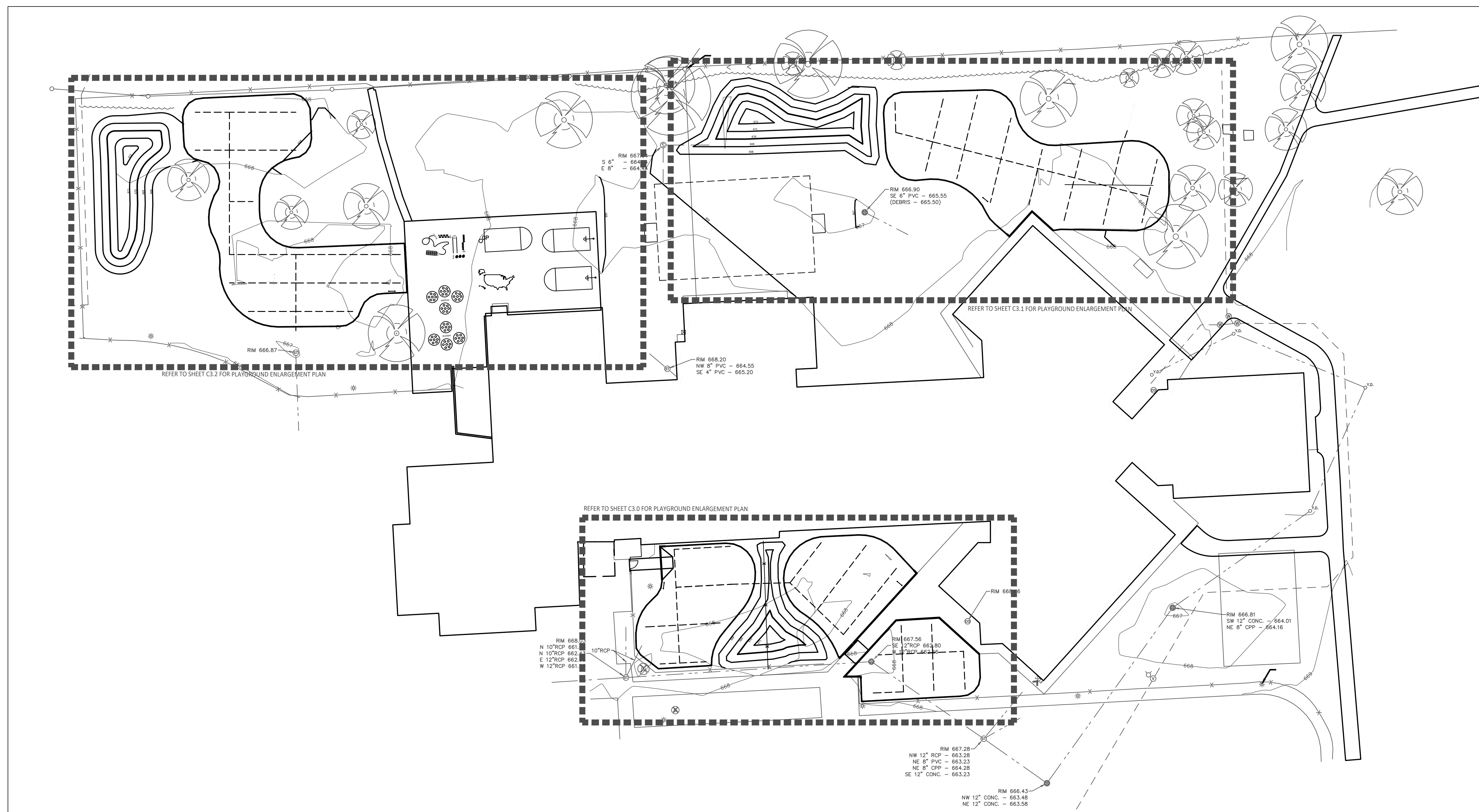

1 Overall Playground Grading Plan
Scale: 1"=30'-0"

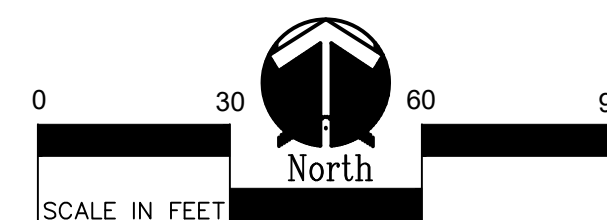

GRADING NOTES:

1. SURVEY OF EXISTING CONDITIONS PROVIDED BY PEA GROUP, 1849 POND RUN, AUBURN HILLS, MICHIGAN, 48326, (248)689-9090.
2. VERIFY LOCATIONS OF ALL BELOW GRADE UTILITIES PRIOR TO BEGINNING WORK. 72 HOURS BEFORE YOU DIG CALL "MISS DIG" AT 1-800-482-7373.
3. ALL NEW PAVEMENTS AND TURF AREAS ARE INTENDED TO DRAIN FREELY WITH NO PONDING. IF THIS CANNOT BE ACHIEVED USING THE PROPOSED GRADES, NOTIFY THE OWNER'S REPRESENTATIVE IMMEDIATELY FOR RESOLUTION.
4. ALL NEW PAVEMENT ELEVATIONS AT EXTERIOR DOORS SHALL MATCH EXISTING FINISH FLOOR ELEVATIONS, TYPICAL.
5. ADJUST TOP OF EXISTING MANHOLES, CATCH BASINS, VAULT COVERS, ETC. TO NEW FINISH GRADE AS REQUIRED.
6. SEE SITE CIVIL PLANS FOR ALL ADDITIONAL SITE UTILITY DEMOLITION AND CONSTRUCTION.
7. ALL TOPSOIL AND EXCESS FILL MATERIAL SHALL BE STOCKPILED ON SITE SEPARATELY FOR LATER RE-USE. LOCATE STOCKPILES IN AREAS AS DIRECTED BY CONSTRUCTION MANAGER AND PROTECT FROM EFFECTS OF EROSION.

PROPOSED FEATURES LEGEND:

	EXISTING CONTOURS
	EXISTING SPOT ELEVATIONS
	PROPOSED CONTOURS
	PROPOSED SPOT ELEVATIONS
	DIRECTION AND PERCENTAGE OF SLOPE
	NEW STORMWATER STRUCTURE, REFER TO CIVIL PLANS
	PLAYGROUND UNDER DRAIN PIPE, REFER TO DETAIL 14/CA 0
FFE	FINISH FLOOR ELEVATION
INV	INVERT ELEVATION
TC	TOP OF CURB ELEVATION
IBC	INNER BOTTOM OF CURB ELEVATION (LOOSE FILL ELEVATION)
OBC	OUTER BOTTOM OF CURB ELEVATION (TURF ELEVATION)
HP	HIGH POINT
	WORK LIMIT LINE

BARRIER-FREE NOTES

BARRIER-FREE PARKING AND ACCESSIBLE ROUTE(S) MUST COMPLY WITH THE AMERICANS WITH DISABILITIES ACT AND MICHIGAN BARRIER-FREE CODE REQUIREMENTS, INCLUDING BUT NOT LIMITED TO THE FOLLOWING:
 -1.50 (2%) MAXIMUM CROSS-SLOPE ON ACCESSIBLE ROUTE.
 -NO CHANGES IN LEVEL GREATER THAN 1/2" ALONG ACCESSIBLE ROUTE.
 -1:20 (5%) MAXIMUM LONGITUDINAL SLOPE ON ACCESSIBLE ROUTE (EXCEPT WHERE RAMPS ARE PROVIDED).
 -1.50 (2%) MAXIMUM SLOPE (IN ANY DIRECTION) IN B.F. PARKING AND ACCESS AISLES.

IMPORTANT NOTE

GENERAL EARTHWORK NOTE:

CUTS AND FILLS AT THIS SITE MAY OR MAY NOT BALANCE. IT IS THE CONTRACTOR'S RESPONSIBILITY TO VERIFY THE REQUIRED EARTHWORK VOLUMES BASED ON THE GRADING PLAN SHOWN. IF FILL IS REQUIRED, THE CONTRACTOR SHALL INCLUDE THE REQUIRED VOLUME OF IMPORTED CLASS II SAND IN THE BASE BID PROPOSAL. IF EXCESS SOILS NEED TO BE SPOILED, THE CONTRACTOR SHALL INCLUDE HAULING AND SPOILING SOILS OFF SITE IN THE BASE BID PROPOSAL. NO CONTRACT COST ADJUSTMENTS WILL BE CONSIDERED FOR EARTHWORK REQUIRED TO BALANCE THE SITE.

IMPORTANT NOTE



TMP ARCHITECTURE INC
 1391 WEST SQUARE LAKE ROAD
 BLOOMFIELD HILLS - MICHIGAN - 48302
 PH - 248.338.4561 FX - 248.338.0023
 EM - INFO@TMP-ARCHITECTURE.COM

REGISTRATION SEAL

CONSULTANT



350 East Michigan Avenue Suite #415
 Kalamazoo Michigan 49007
 Phone (269) 381-3357
 Fax (269) 381-2944

PROJECT TITLE

**Morse
 Elementary School
 Playground Renovation
 Bld Package No.01A**

**Troy School District
 Troy, Michigan**

**DRAWING TITLE
 Overall Playground
 Grading Plan &
 Enlargement Plan
 Pre-K & Kindergarten**

ISSUE DATES

DATE: ISSUED FOR:

DATE:	ISSUED FOR:

PROJECT NO.

22093B

DRAWING NO.

C3.0

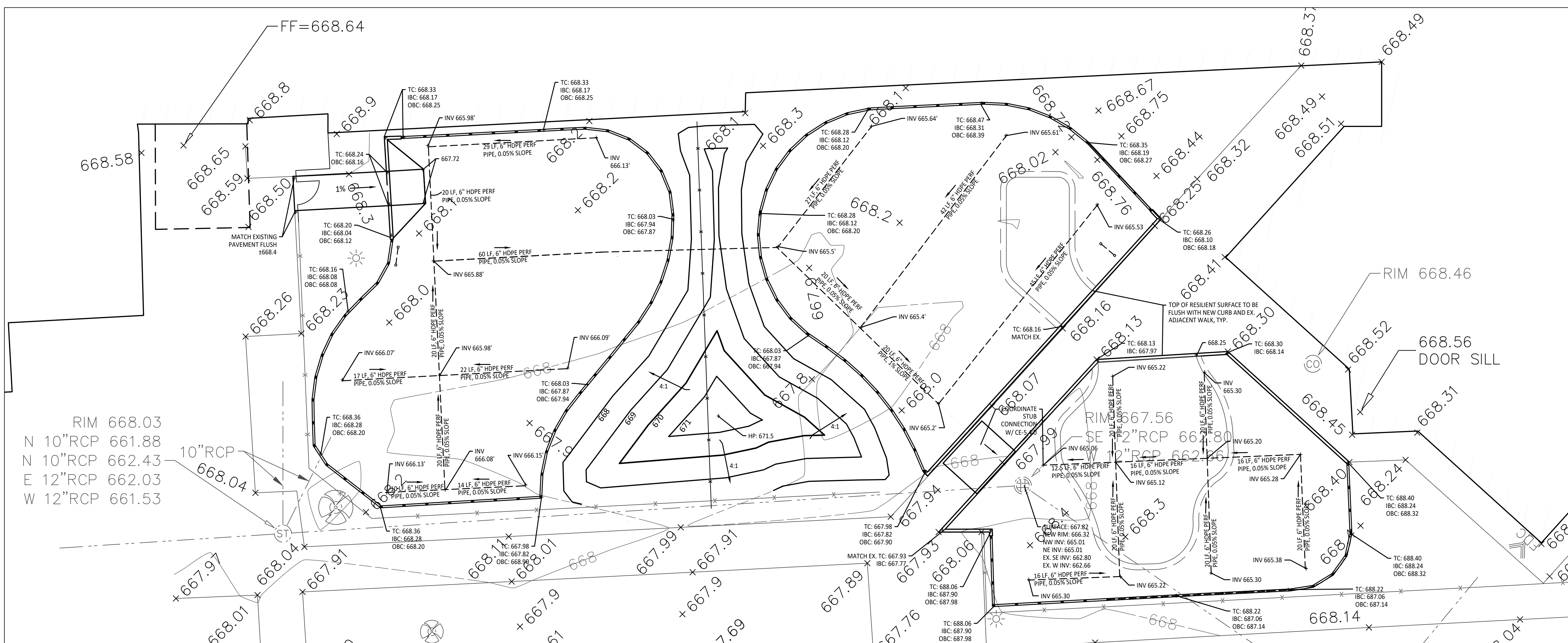

2 Playground Grading Enlargement Plan - Pre-K + Kindergarten
Scale: 1"=30'-0"

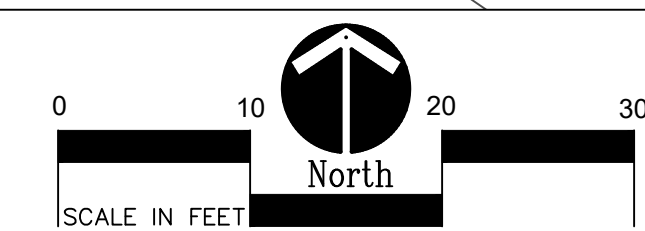

EROSION CONTROL REQUIREMENTS:

ALL CONSTRUCTION SHALL COMPLY WITH THE SOIL EROSION AND SEDIMENTATION CONTROL ACT (P.A. 347 OF 1972, AS AMENDED) AS ADMINISTERED BY CITY OF TROY AND OAKLAND COUNTY. THE FOLLOWING EROSION CONTROL DEVICES ARE REFERENCED IN THE STANDARD EROSION CONTROL HANDBOOK PUBLISHED BY THE MICHIGAN DEPARTMENT OF TRANSPORTATION. (MDOT DRAWING R-96-C, 8-9-2003)
 ALL TEMPORARY EROSION CONTROL DEVICES SHALL BE REMOVED AT THE END OF CONSTRUCTION. TEMPORARY EROSION CONTROL DEVICES SHOULD BE IN PLACE PRIOR TO EXCAVATION, TO THE EXTENT POSSIBLE.

KEY	DESCRIPTION	TEMPORARY / PERMANENT
□	PERMANENT/TEMPORARY SEEDING	P

BARRIER-FREE NOTES

BARRIER-FREE PARKING AND ACCESSIBLE ROUTE(S) MUST COMPLY WITH THE AMERICANS WITH DISABILITIES ACT AND MICHIGAN BARRIER-FREE CODE REQUIREMENTS, INCLUDING BUT NOT LIMITED TO THE FOLLOWING:
 - 1:50 (2%) MAXIMUM CROSS-SLOPE ON ACCESSIBLE ROUTE
 - NO CHANGES IN LEVEL GREATER THAN 1/2" ALONG ACCESSIBLE ROUTE
 - 1:20 (5%) MAXIMUM LONGITUDINAL SLOPE ON ACCESSIBLE ROUTE (EXCEPT WHERE RAMPS ARE PROVIDED)
 - 1:50 (2%) MAXIMUM SLOPE (IN ANY DIRECTION) IN B.F. PARKING AND ACCESS AREAS.

IMPORTANT NOTE

GENERAL EARTHWORK NOTE:
 CUTS AND FILLS AT THIS SITE MAY OR MAY NOT BALANCE. IT IS THE CONTRACTOR'S RESPONSIBILITY TO VERIFY THE REQUIRED EARTHWORK VOLUMES BASED ON THE GRADING PLAN SHOWN. IF FILL IS REQUIRED, THE CONTRACTOR SHALL INCLUDE THE REQUIRED VOLUME OF IMPORTED CLASS II SAND IN THE BASE BID PROPOSAL. IF EXCESS SOILS NEED TO BE SPOILED, THE CONTRACTOR SHALL INCLUDE HAULING AND SPOILING SOILS OFF SITE IN THE BASE BID PROPOSAL. NO CONTRACT COST ADJUSTMENTS WILL BE CONSIDERED FOR EARTHWORK REQUIRED TO BALANCE THE SITE.

IMPORTANT NOTE

GRADING NOTES:

1. SURVEY OF EXISTING CONDITIONS PROVIDED BY PEA GROUP, 1849 POND RUN, AUBURN HILLS, MICHIGAN, 48226, (248)688-9090.
2. VERIFY LOCATIONS OF ALL BELOW GRADE UTILITIES PRIOR TO BEGINNING WORK. 72 HOURS BEFORE YOU DIG CALL "MISS DIG" AT 1-800-482-7171.
3. ALL NEW PAVEMENTS AND TURF AREAS ARE INTENDED TO DRAIN FREELY WITH NO PONDING. IF THIS CANNOT BE ACHIEVED USING THE PROPOSED GRADES, NOTIFY THE OWNER'S REPRESENTATIVE IMMEDIATELY FOR RESOLUTION.
4. ALL NEW PAVEMENT ELEVATIONS AT EXTERIOR DOORS SHALL MATCH EXISTING FINISH FLOOR ELEVATIONS, TYPICAL.
5. ADJUST TOP OF EXISTING MANHOLES, CATCH BASINS, VAULT COVERS, ETC. TO NEW FINISH GRADE AS REQUIRED.
6. SEE SITE CIVIL PLANS FOR ALL ADDITIONAL SITE UTILITY DEMOLITION AND CONSTRUCTION.
7. ALL TOPSOIL AND EXCESS FILL MATERIAL SHALL BE STOCKPILED ON SITE SEPARATELY FOR LATER RE-USE. LOCATE STOCKPILES IN AREAS AS DIRECTED BY CONSTRUCTION MANAGER AND PROTECT FROM EFFECTS OF EROSION.

PROPOSED FEATURES LEGEND:

- - - 695 - - - EXISTING CONTOURS
- +711.55 CONC EXISTING SPOT ELEVATIONS
- - - 710 - - - PROPOSED CONTOURS
- 949.5 + PROPOSED SPOT ELEVATIONS
- 2% DIRECTION AND PERCENTAGE OF SLOPE
- NEW STORMWATER STRUCTURE, REFER TO CIVIL PLANS
- - - PLAYGROUND UNDER DRAIN PIPE, REFER TO DETAIL 14/CA.0
- FFE FINISH FLOOR ELEVATION
- INV INVERT ELEVATION
- TC TOP OF CURB ELEVATION
- IBC INNER BOTTOM OF CURB ELEVATION (LOOSE FILL ELEVATION)
- OBC OUTER BOTTOM OF CURB ELEVATION (TURF ELEVATION)
- HP HIGH POINT
- ███ WORK LIMIT LINE



TMP ARCHITECTURE INC
 1391 WEST SQUARE LAKE ROAD
 BLOOMFIELD HILLS - MICHIGAN - 48302
 PH - 248.338.4661 FX - 248.338.0023
 EM - INFO@TMP-ARCHITECTURE.COM

REGISTRATION SEAL

CONSULTANT



350 East Michigan Avenue Suite #415
 Kalamazoo Michigan 49007
 Phone (269) 381-3357
 Fax (269) 381-2944

PROJECT TITLE

**Morse Elementary School
 Playground Renovation
 Bld Package No.01A**

**Troy School District
 Troy, Michigan**

DRAWING TITLE

**Playground
 Grading Plan
 Enlargements
 - 1st - 2nd Grade**

ISSUE DATES

11-09-23 CONSTRUCTION DOCUMENTS

DATE ISSUED FOR:

DRAWN	...
CHECKED	...
APPROVED	...

PROJECT NO.

22093B

DRAWING NO.

C3.1

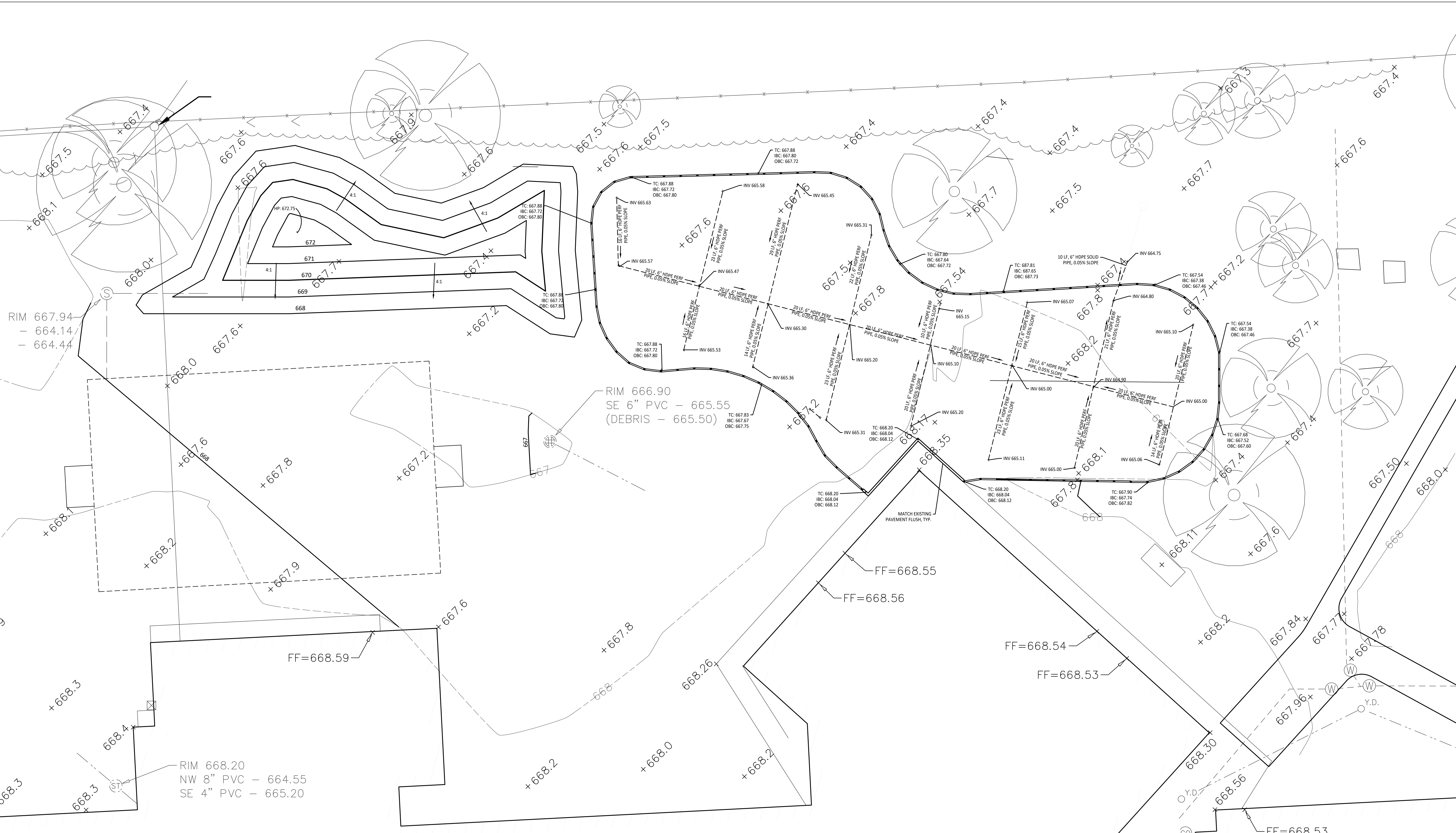

2 Playground Grading Enlargement Plan - 1st-2nd Grade
 Scale: 1"=10'-0"

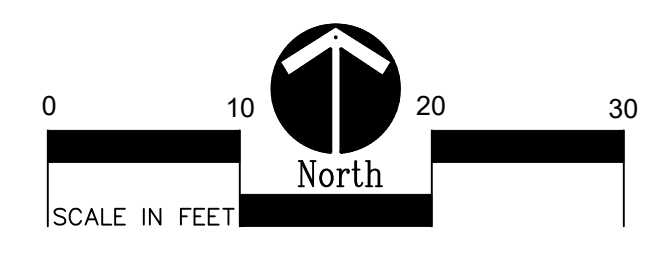

EROSION CONTROL REQUIREMENTS:

ALL CONSTRUCTION SHALL COMPLY WITH THE SOIL EROSION AND SEDIMENTATION CONTROL ACT (P.A. 347 OF 1972, AS AMENDED) AS ADMINISTERED BY CITY OF TROY AND OAKLAND COUNTY. THE FOLLOWING EROSION CONTROL DEVICES ARE REFERENCED IN THE STANDARD EROSION CONTROL HANDBOOK PUBLISHED BY THE MICHIGAN DEPARTMENT OF TRANSPORTATION. (MDOT DRAWING R-96-C, 8-9-2001)
 ALL TEMPORARY EROSION CONTROL DEVICES SHALL BE REMOVED AT THE END OF CONSTRUCTION. TEMPORARY EROSION CONTROL DEVICES SHOULD BE IN PLACE PRIOR TO EXCAVATION, TO THE EXTENT POSSIBLE.

KEY	DESCRIPTION	TEMPORARY / PERMANENT
③	PERMANENT/TEMPORARY SEEDING	P

BARRIER-FREE NOTES

BARRIER-FREE PARKING AND ACCESSIBLE ROUTE(S) MUST COMPLY WITH THE AMERICANS WITH DISABILITIES ACT AND MICHIGAN BARRIER-FREE CODE REQUIREMENTS, INCLUDING BUT NOT LIMITED TO THE FOLLOWING:
 -1:50 (2%) MAXIMUM CROSS-SLOPE ON ACCESSIBLE ROUTE.
 -NO CHANGES IN LEVEL GREATER THAN 1/2" ALONG ACCESSIBLE ROUTE.
 -1:20 (5%) MAXIMUM LONGITUDINAL SLOPE ON ACCESSIBLE ROUTE (EXCEPT WHERE RAMPERS ARE PROVIDED).
 -1:50 (2%) MAXIMUM SLOPE (IN ANY DIRECTION) IN B.F. PARKING AND ACCESS AISLES.

GENERAL EARTHWORK NOTE:

CUTS AND FILLS AT THIS SITE MAY OR MAY NOT BALANCE. IT IS THE CONTRACTOR'S RESPONSIBILITY TO VERIFY THE REQUIRED EARTHWORK VOLUMES BASED ON THE GRADING PLAN SHOWN. IF FILL IS REQUIRED, THE CONTRACTOR SHALL INCLUDE THE REQUIRED VOLUME OF IMPORTED CLASS II SAND IN THE BASE BID PROPOSAL. IF EXCESS SOILS NEED TO BE SPOILED, THE CONTRACTOR SHALL INCLUDE HAULING AND SPOILING SOILS OFF SITE IN THE BASE BID PROPOSAL. NO CONTRACT COST ADJUSTMENTS WILL BE CONSIDERED FOR EARTHWORK REQUIRED TO BALANCE THE SITE.

GRADING NOTES:

- SURVEY OF EXISTING CONDITIONS PROVIDED BY PEA GROUP, 1849 POND RUN, AUBURN HILLS, MICHIGAN, 48326, (248)689-9090.
- VERIFY LOCATIONS OF ALL BELOW GRADE UTILITIES PRIOR TO BEGINNING WORK. 72 HOURS BEFORE YOU DIG CALL "MISS DIG" AT 1-800-482-7171.
- ALL NEW PAVEMENTS AND TURF AREAS ARE INTENDED TO DRAIN FREELY WITH NO PONDING. IF THIS CANNOT BE ACHIEVED USING THE PROPOSED GRADES, NOTIFY THE OWNER'S REPRESENTATIVE IMMEDIATELY FOR RESOLUTION.
- ALL NEW PAVEMENT ELEVATIONS AT EXTERIOR DOORS SHALL MATCH EXISTING FINISH FLOOR ELEVATIONS, TYPICAL.
- ADJUST TOP OF EXISTING MANHOLES, CATCH BASINS, VAULT COVERS, ETC. TO NEW FINISH GRADE AS REQUIRED.
- SEE SITE CIVIL PLANS FOR ALL ADDITIONAL SITE UTILITY DEMOLITION AND CONSTRUCTION.
- ALL TOPSOIL AND EXCESS FILL MATERIAL SHALL BE STOCKPILED ON SITE SEPARATELY FOR LATER RE-USE. LOCATE STOCKPILES IN AREAS AS DIRECTED BY CONSTRUCTION MANAGER AND PROTECT FROM EFFECTS OF EROSION.

PROPOSED FEATURES LEGEND:

- 695 EXISTING CONTOURS
- 71.95 EXISTING SPOT ELEVATIONS
- 710 PROPOSED CONTOURS
- 949.5 + PROPOSED SPOT ELEVATIONS
- 2% DIRECTION AND PERCENTAGE OF SLOPE
- NEW STORMWATER STRUCTURE, REFER TO CIVIL PLANS
- PLAYGROUND UNDER DRAIN PIPE, TO DETAIL 14/C4.0
- FFE FINISH FLOOR ELEVATION
- INV INVERT ELEVATION
- TC TOP OF CURB ELEVATION
- IBC INNER BOTTOM OF CURB ELEVATION (LOOSE FILL ELEVATION)
- OBC OUTER BOTTOM OF CURB ELEVATION (TURF ELEVATION)
- HP HIGH POINT
- WORK LIMIT LINE

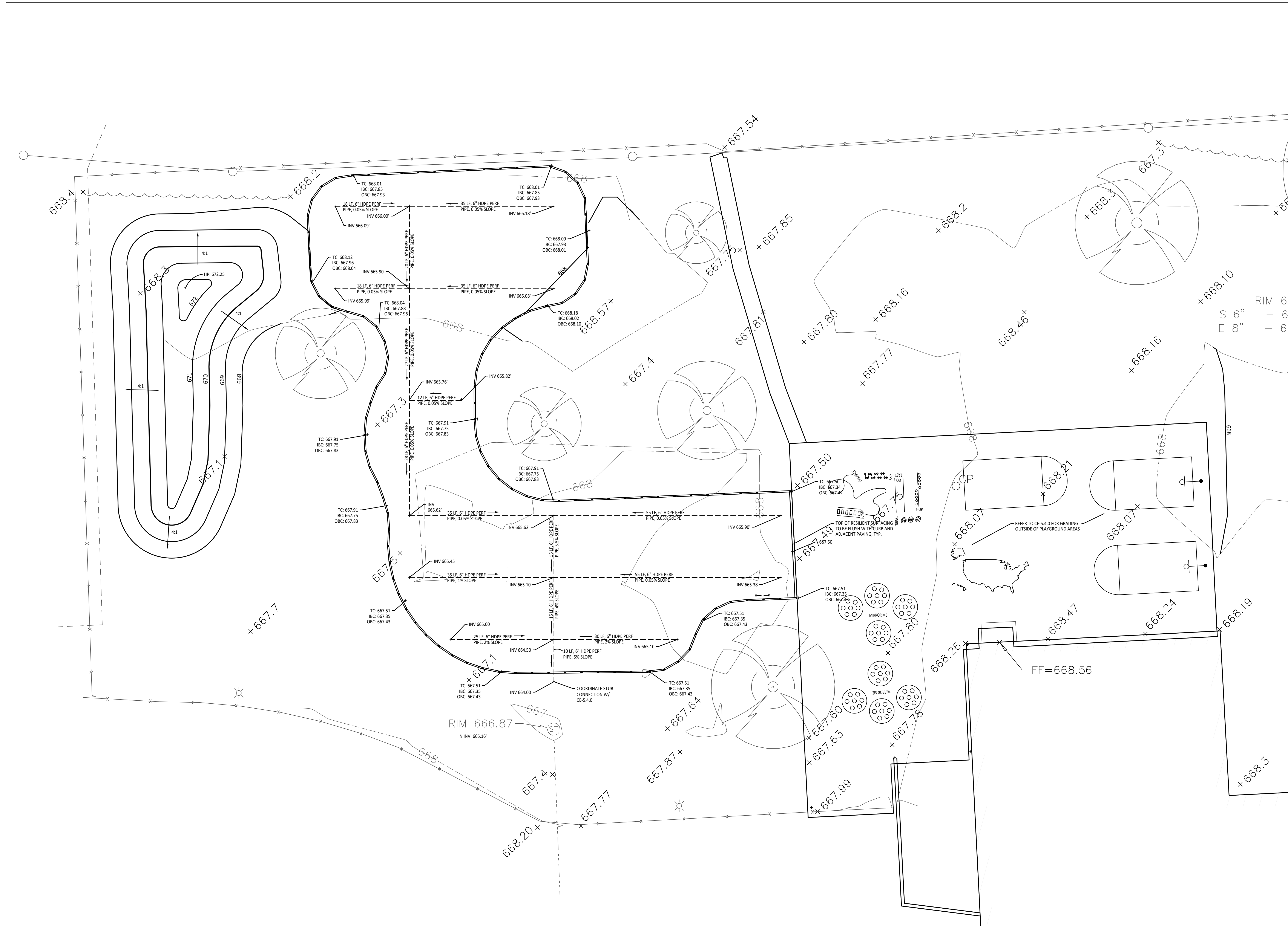

TMP ARCHITECTURE

TMP ARCHITECTURE INC
 1391 WEST SQUARE LAKE ROAD
 BLOOMFIELD HILLS - MICHIGAN - 48302
 PH - 248.338.4561 FX - 248.338.0223
 EM - INFO@TMP-ARCHITECTURE.COM

REGISTRATION SEAL

CONSULTANT

OCBA LANDSCAPE ARCHITECTS

350 East Michigan Avenue Suite #415
 Kalamazoo Michigan 49007
 Phone (269) 381-3357
 Fax (269) 381-2944

PROJECT TITLE
**Morse Elementary School
 Playground Renovation
 Bld Package No.01A**

**Troy School District
 Troy, Michigan**

DRAWING TITLE
**Playground Grading Plan
 Enlargements
 - 3rd - 5th Grade**

ISSUE DATES

DATE	ISSUED FOR:

PROJECT NO.
22093B

DRAWING NO.
C3.2

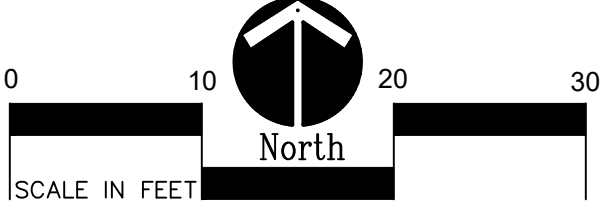

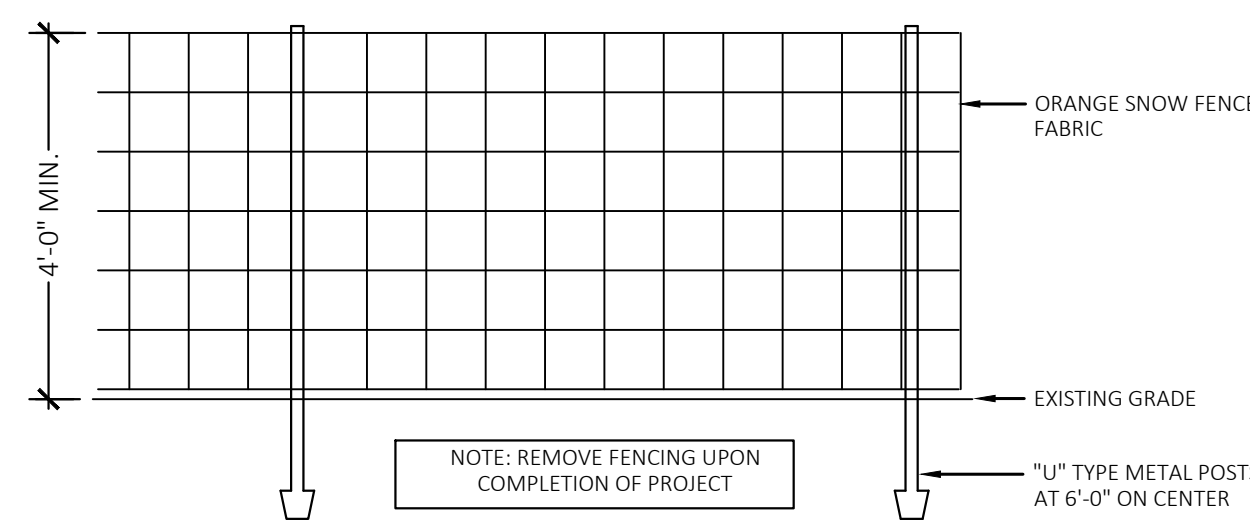

1 Tree Protection Fencing Detail
NOT TO SCALE

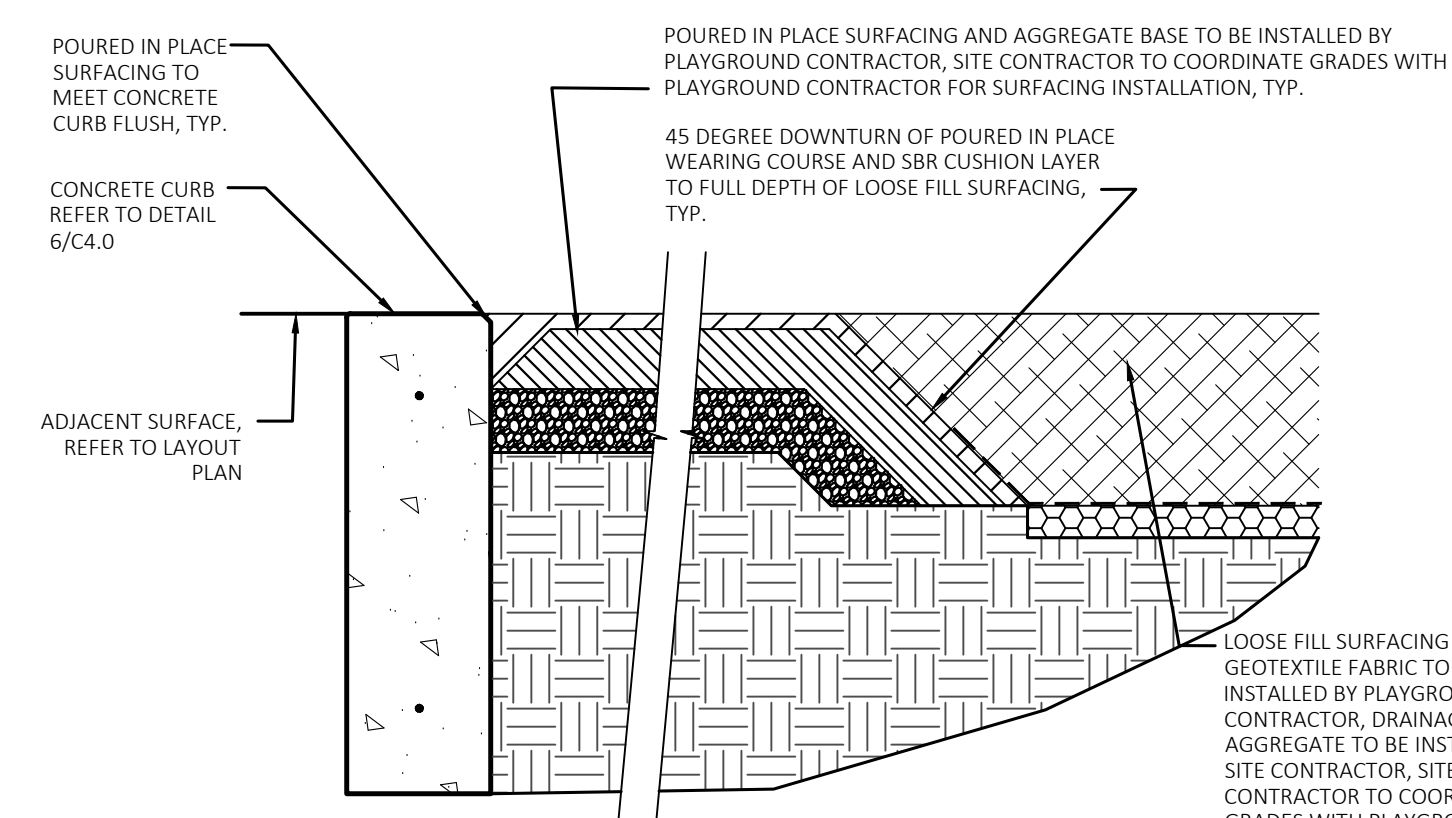

7 Poured in Place Surfacing Transition to Loose Fill Surfacing and Concrete Curb Detail
NOT TO SCALE

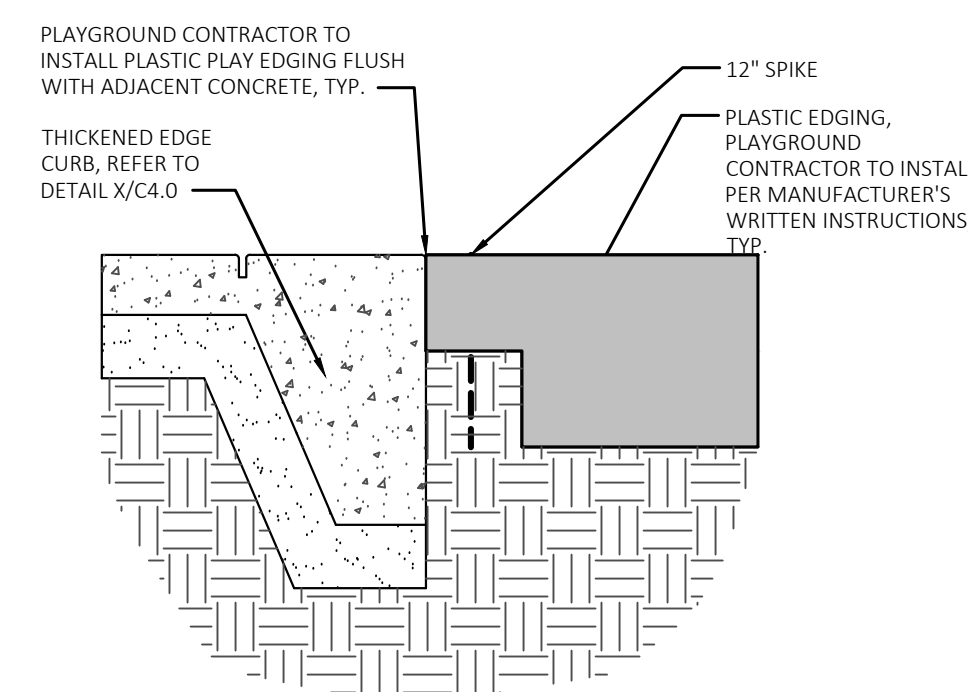

12 Thickened Edge Curb to Plastic Edging Transition Detail
Not to Scale

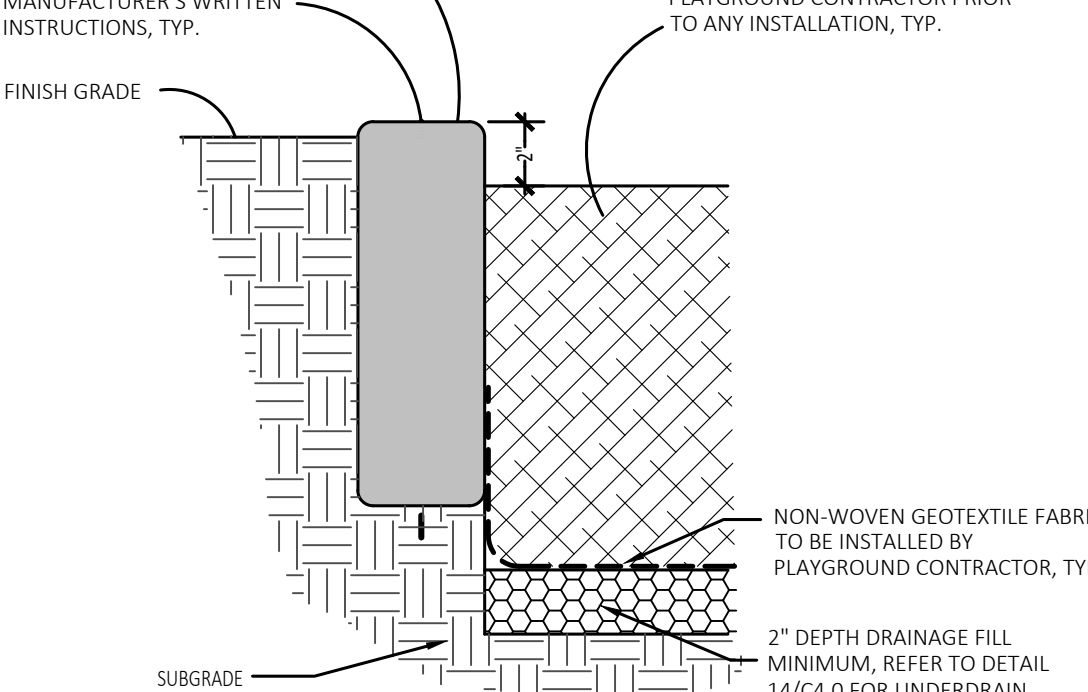

13 Plastic Edging Detail
Not to Scale

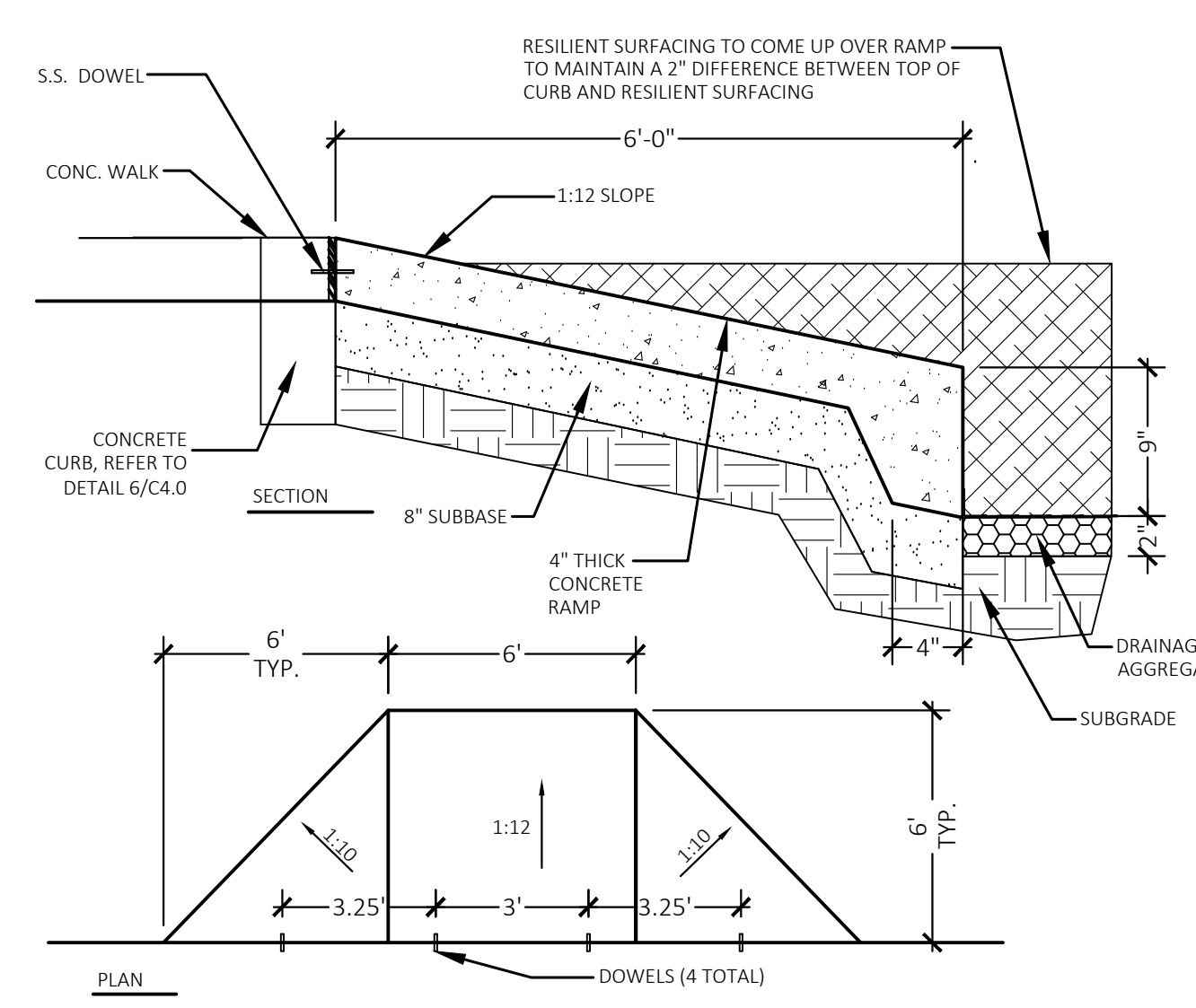

16 Access Ramp to Play Areas Detail
NOT TO SCALE

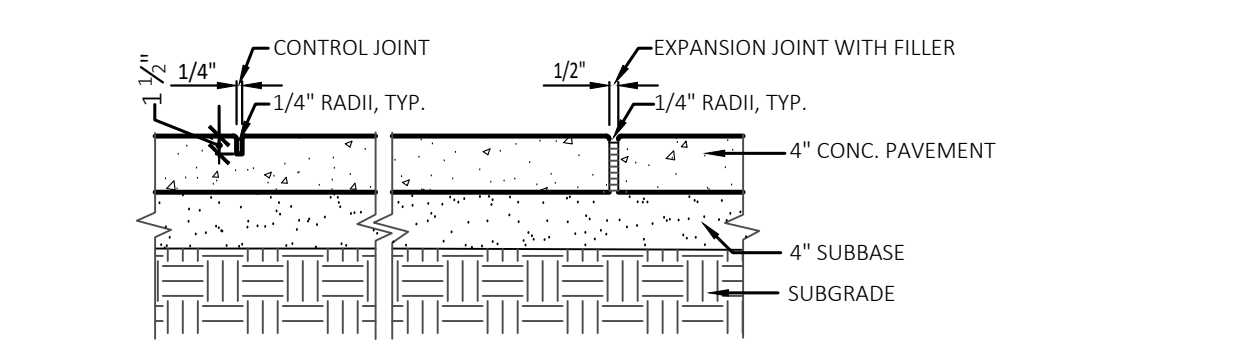

2 Section-Conc. Paving + Jointing
NOT TO SCALE

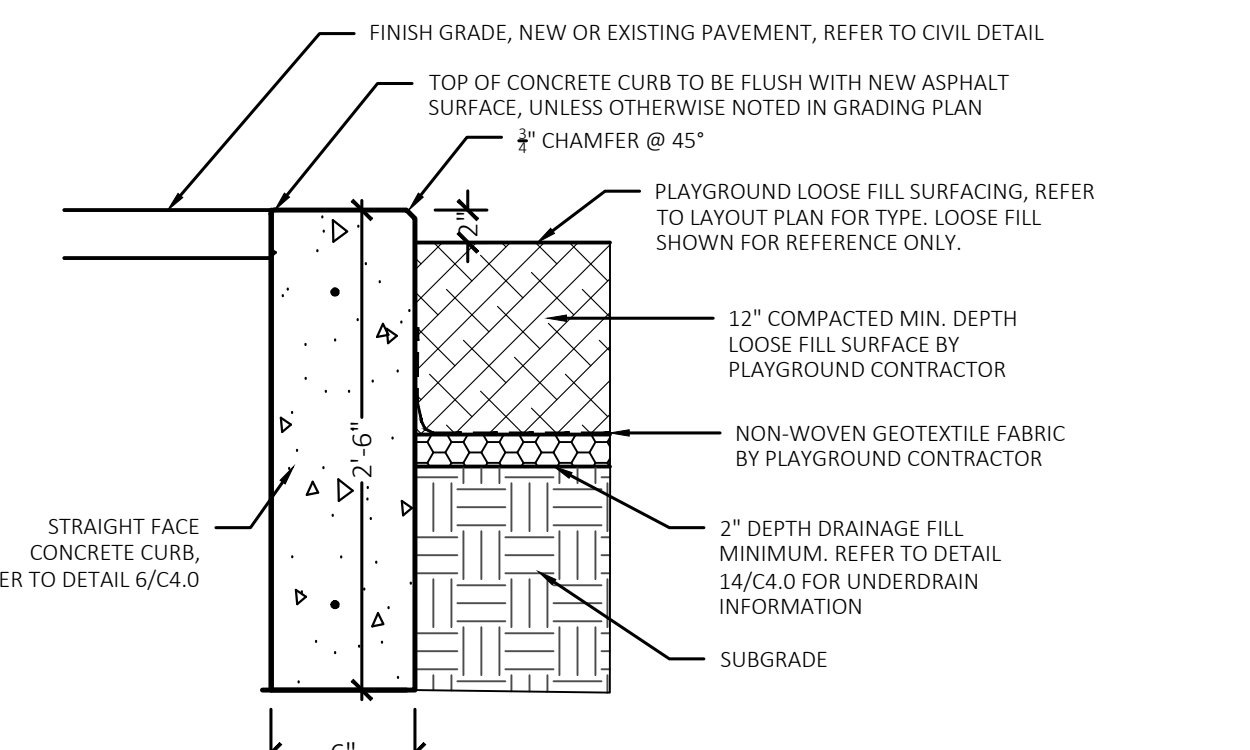

3 New Concrete Curb to Paving Loose Fill Play Surfacing Detail
Not to Scale

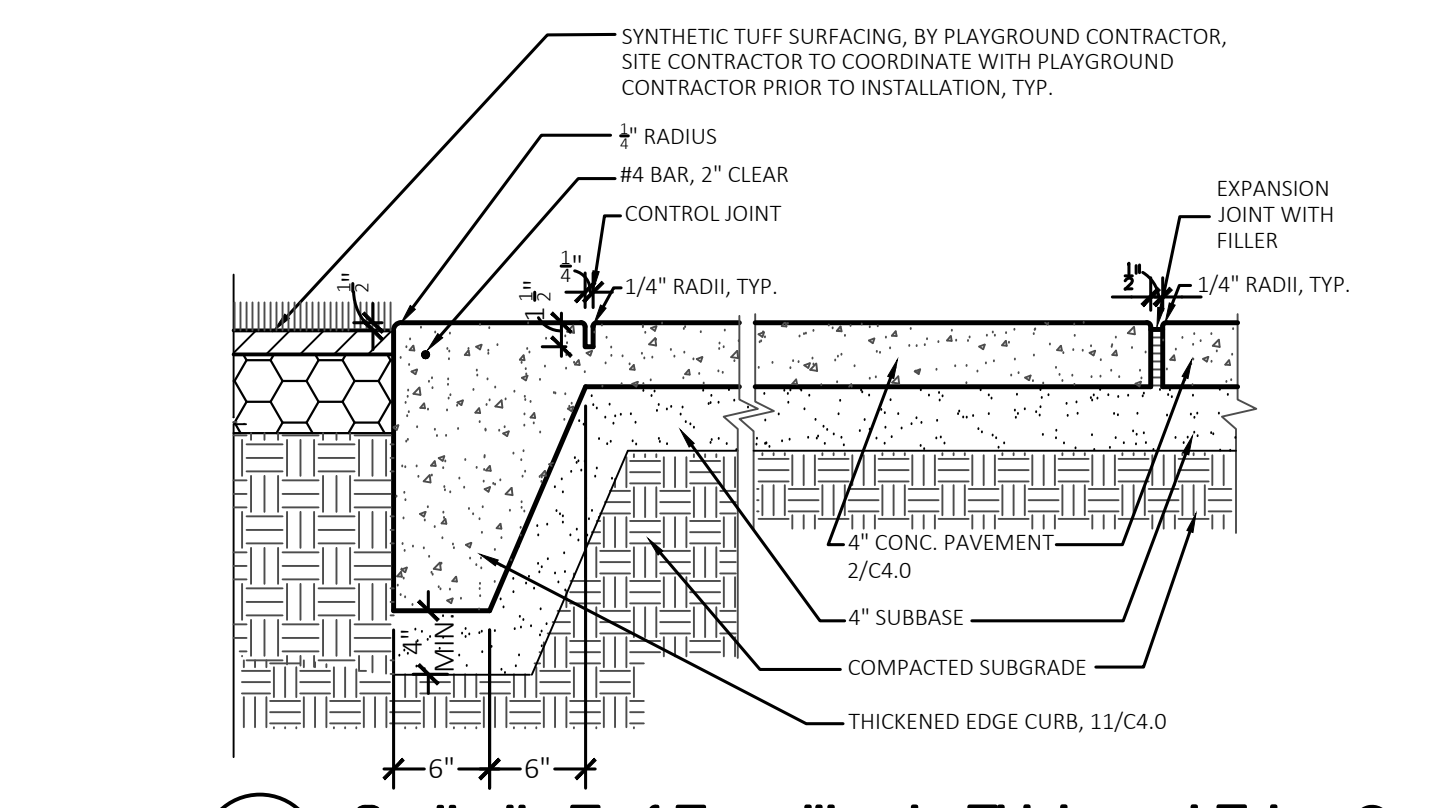

8 Synthetic Turf Transition to Thickened Edge Concrete
Not to Scale

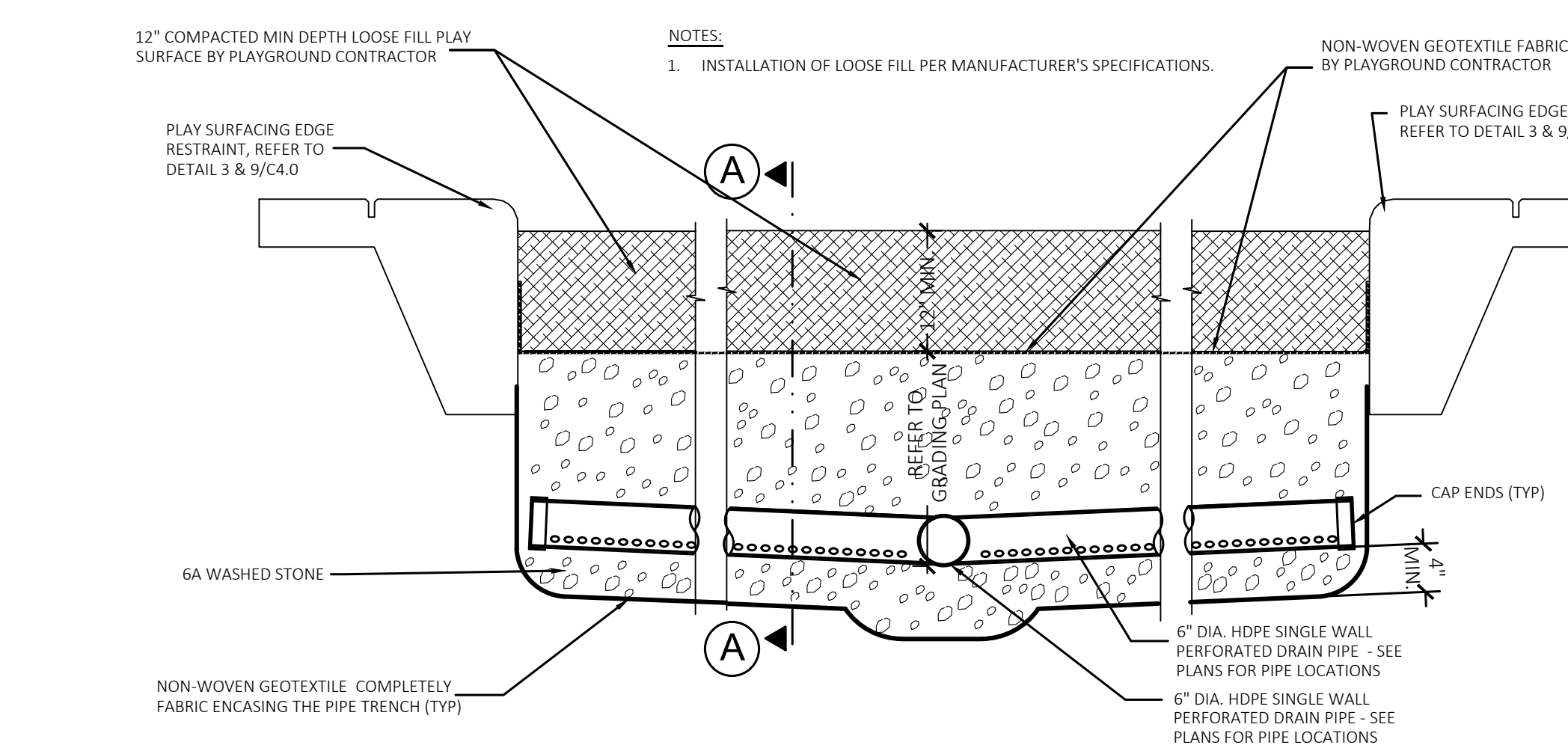

14 Playground Drainage Detail
NOT TO SCALE

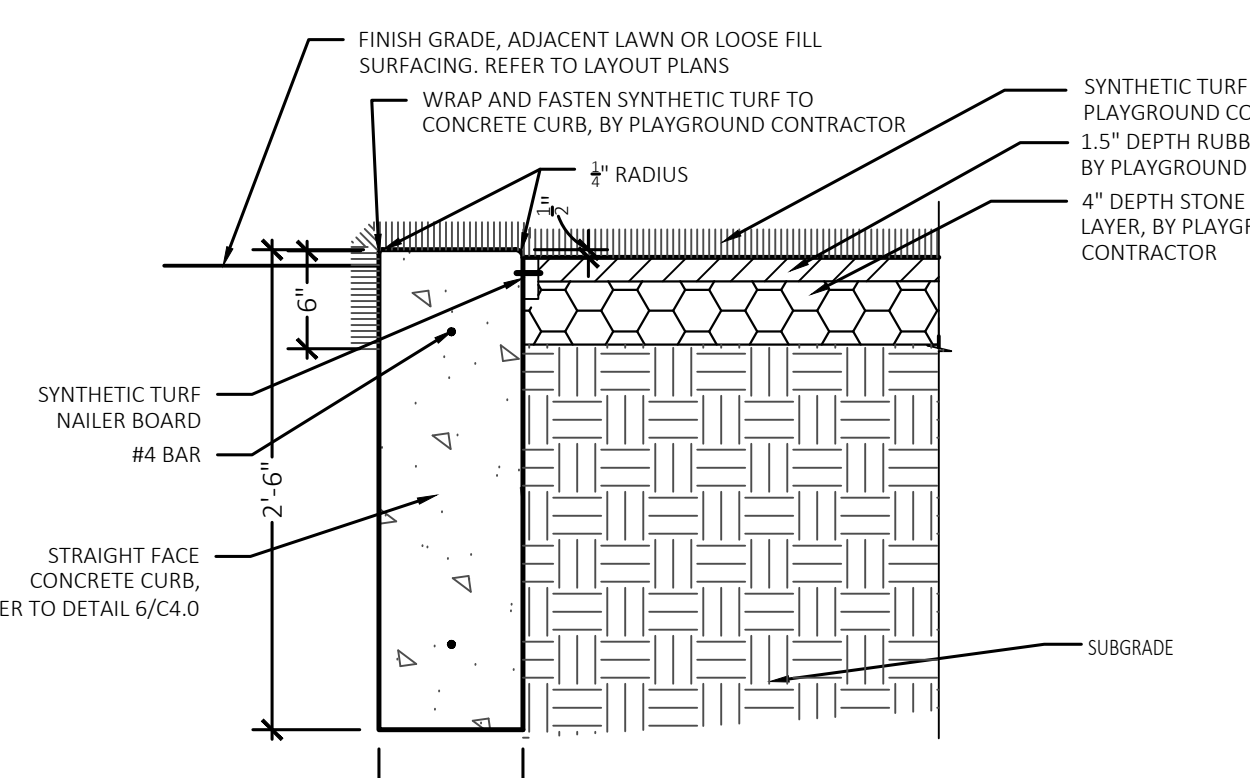

4 Synthetic Turf Wrap Over Concrete Curb Detail
Not to Scale

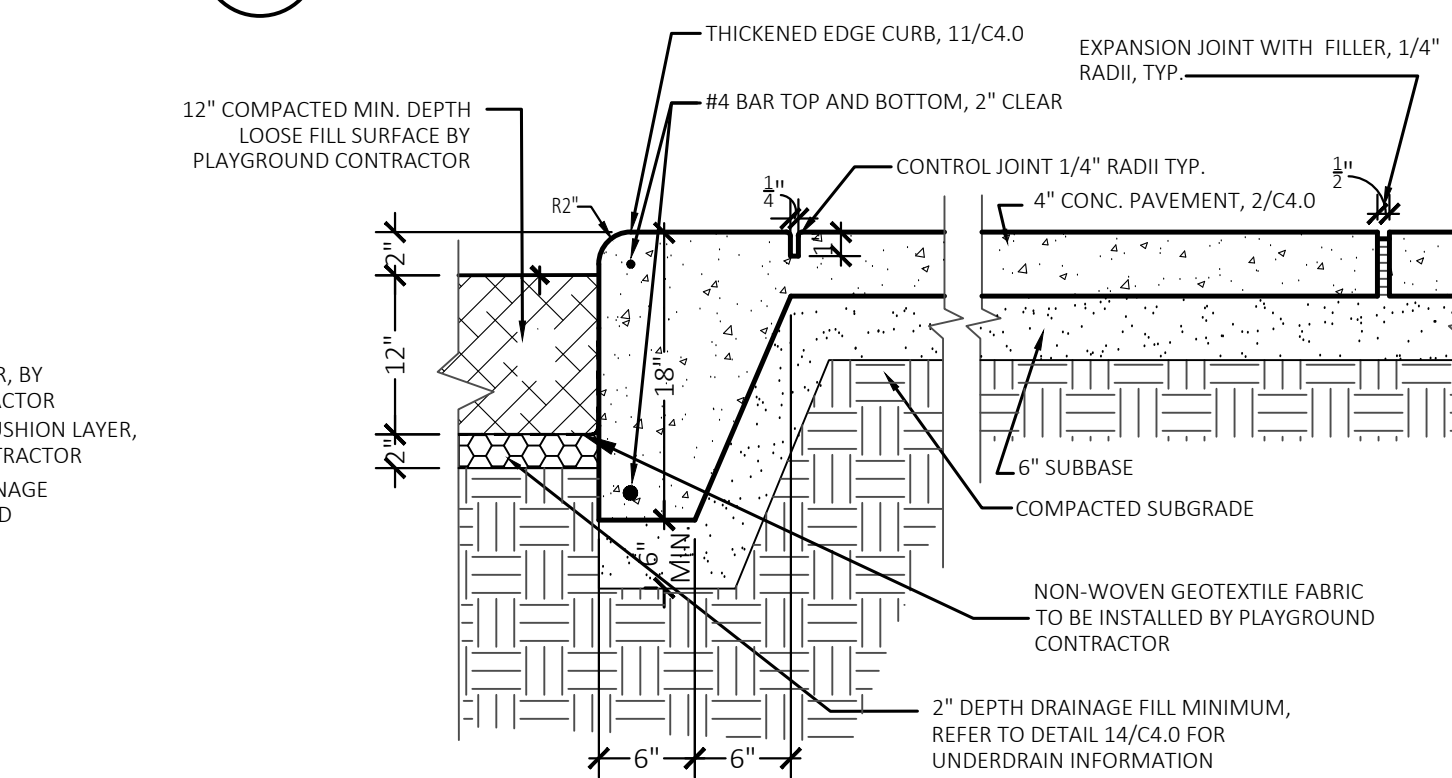

9 Loose Fill Surfacing to Thickened Edge Concrete Detail
NOT TO SCALE

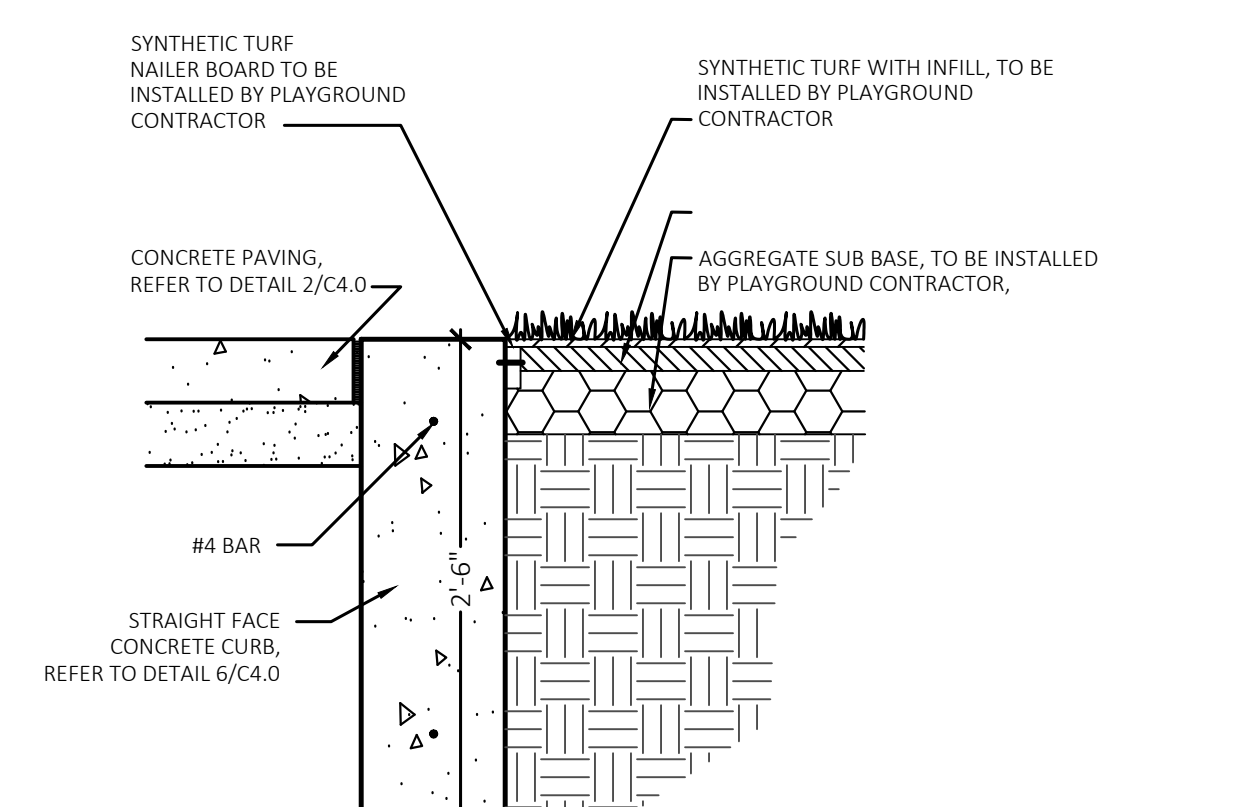

5 Synthetic Turf Transition to Concrete Curb Detail
NOT TO SCALE

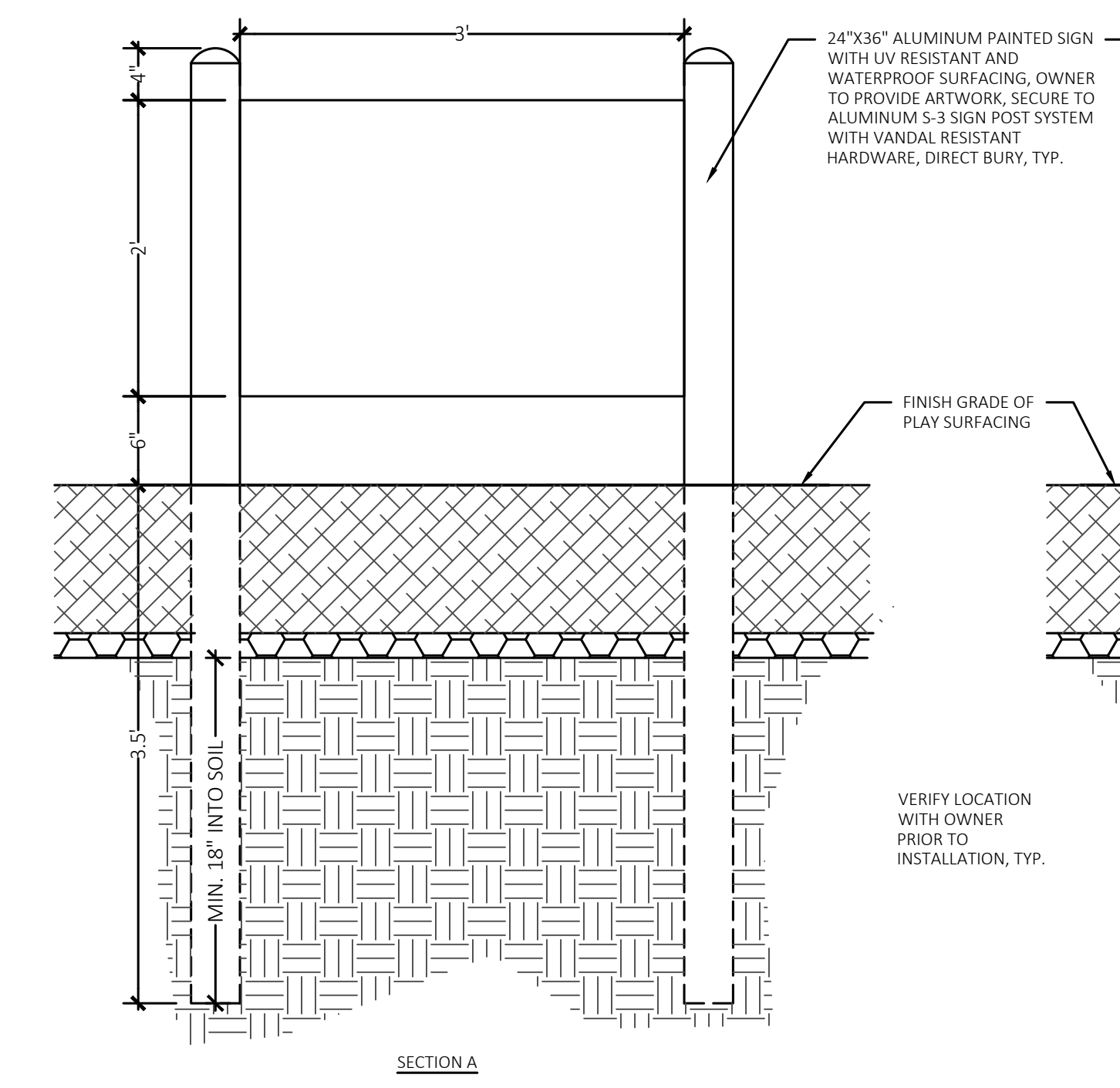

10 Communication Board Detail
Not to Scale

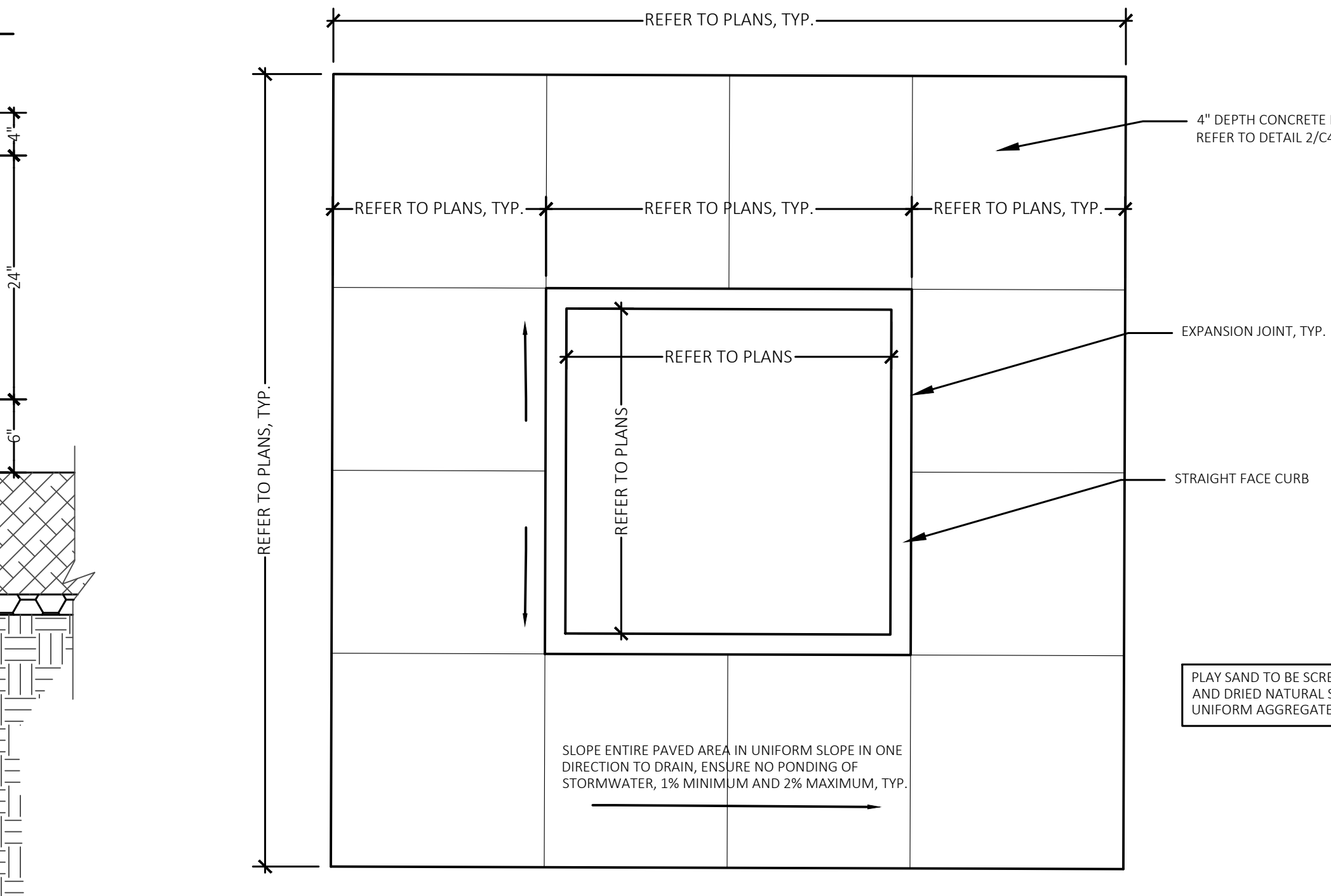

15 Concrete Sand Box Detail
Not to Scale

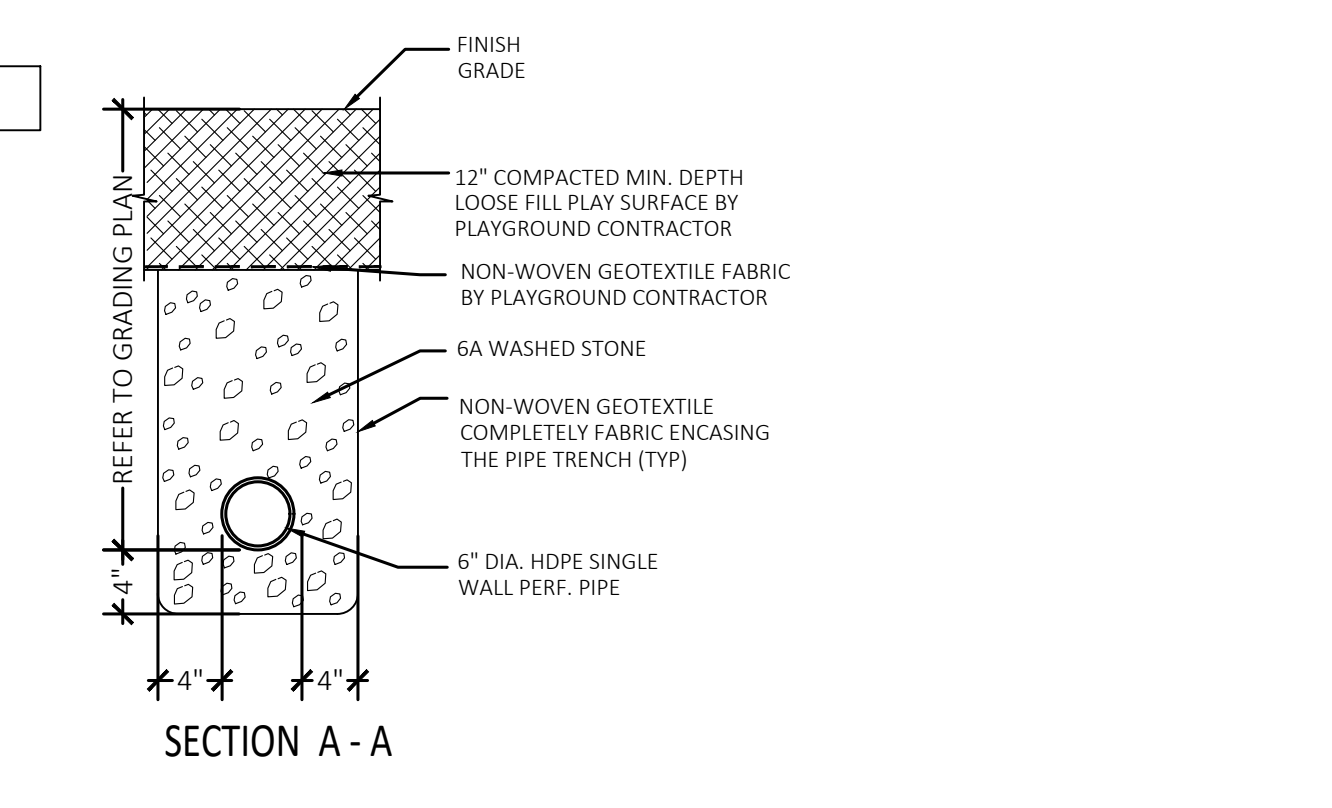

17 For Reference Basketball Post Footing Detail
Not to Scale

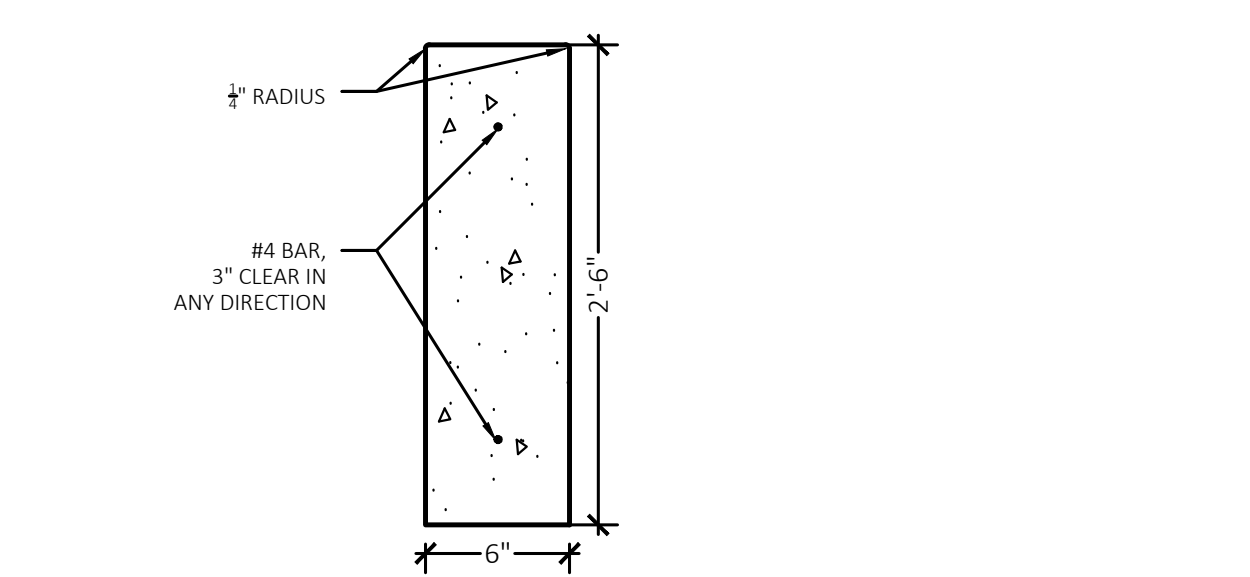

6 Straight Face Concrete Curb Detail
NOT TO SCALE

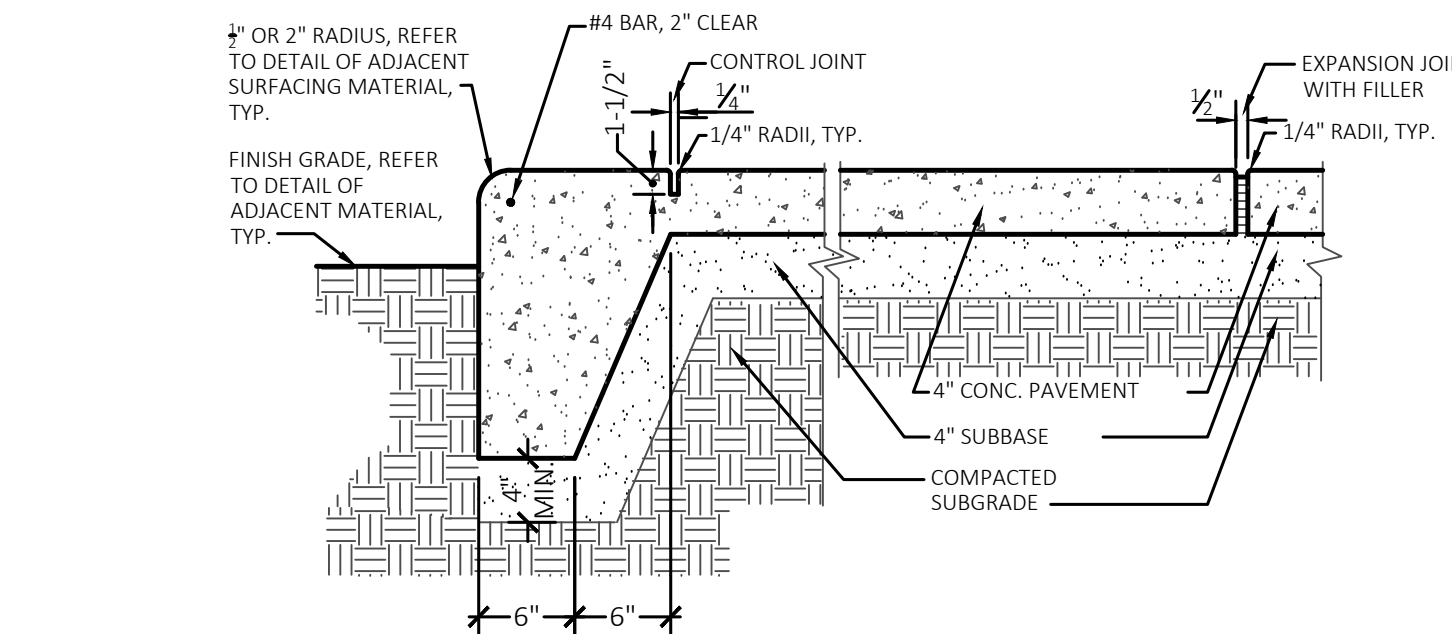

11 Thickened Edge Curb Detail
Not to Scale

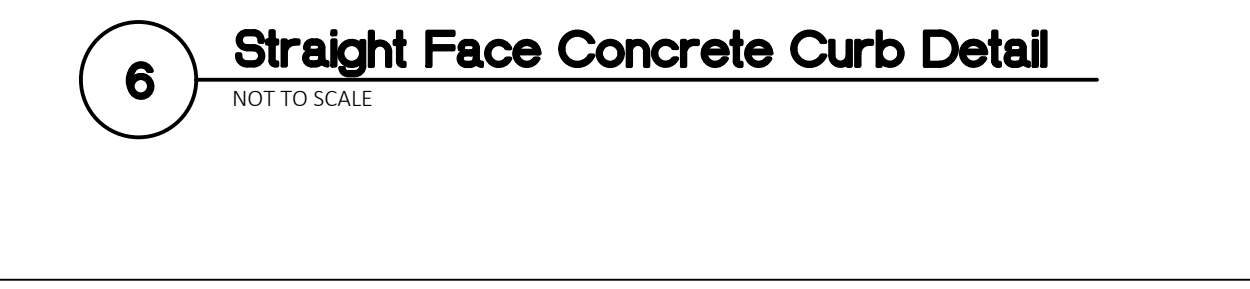

18 Concrete Curb to Plastic Edging Transition Detail
Not to Scale



TMP ARCHITECTURE INC
1391 WEST SQUARE LAKE ROAD
BLOOMFIELD HILLS - MICHIGAN - 48302
PH - 248.338.4561 FX - 248.338.0023
EM - INFO@TMPARCHITECTURE.COM

REGISTRATION SEAL

CONSULTANT



350 East Michigan Avenue Suite #415
Kalamazoo Michigan 49007
Phone (269) 381-3357
Fax (269) 381-2944

PROJECT TITLE
Morse Elementary School Playground Renovation Bld Package No.01A

Troy School District
Troy, Michigan

DRAWING TITLE
Details

ISSUE DATES

11-09-23 CONSTRUCTION DOCUMENTS

DATE ISSUED FOR:

DRAWN

CHECKED

APPROVED

PROJECT NO.
22093B

DRAWING NO.
C4.0



TMP ARCHITECTURE INC

1591 WEST SQUARE LAKE ROAD
BLOOMFIELD HILLS - MICHIGAN - 48302
PH - 248.538.6963 FX - 248.538.0223
EM - INFO@TMP-ARCHITECTURE.COM

REGISTRATION SEAL

CONSULTANT



t: 844.813.2949
www.peagroup.com

PROJECT TITLE

**Morse
Elementary School**
475 CHERRY AVENUE

**Playground Renovation
Bid Package No.01A**

**Troy School District
Troy, Michigan**

DRAWING TITLE
Topographic Survey

ISSUE DATES

11-9-2023 CONSTRUCTION DOCUMENTS

DATE ISSUED FOR:

DRAWN WR

CHECKED RR

APPROVED TD

PROJECT NO.

22093B

DRAWING NO.

CE-5.1.0

BENCHMARKS:
(GPS DERIVED - NAVD88)

BM 302 - MAG NAIL IN THE EAST FACE OF CONCRETE LIGHT POLE
BASE 4105' SW FROM SE BUILDING CORNER
ELEVATION: 669.42

BM 303 - BENCH TIE IN THE SOUTH FACE OF THE EASTERLY MOST
POWER POLE ALONG THE NORTH PROPERTY LINE
ELEVATION: 669.36

FLOODPLAIN NOTE:
BY GRAPHICAL PLOTTING, SITE IS WITHIN ZONE 'X', AN AREA DETERMINED
TO BE OUTSIDE OF THE 0.2% ANNUAL CHANCE FLOODPLAIN, PER FLOOD
INSURANCE RATE MAP NUMBER 26122C042G, DATED JANUARY 19, 2009.

UTILITY INFORMATION

CABLE - COMCAST
CABLE - WOW
ELECTRIC - DTE ENERGY
FIBER OPTICS - COMCAST
FIBER OPTICS - TROY SCHOOL DISTRICT
FIBER OPTICS - WOW
FIBER OPTICS - WINDSTREAM COMMUNICATION
GAS - CONSUMERS
TELEPHONE - AT&T
SANITARY SEWER - CITY OF TROY
STORM - CITY OF TROY
WATER - CITY OF TROY

REFERENCE DRAWINGS:

CABLE - COMCAST
COMMUNICATION - WOW
FIBER OPTICS - EARTHLINK FIBER, DATED 4-11-23
FIBER OPTICS - FIBER LINK, DATED 3-9-23
SANITARY - CITY OF TROY GIS ONLINE, DATED 4-11-23
STORM - CITY OF TROY GIS ONLINE, DATED 4-11-23
TELEPHONE - AT&T, DATED 4-14-23
WATER MAIN - CITY OF TROY GIS ONLINE, DATED 4-11-23

LEGEND:

EX. ON ELEC. POLE & GUY WIRE
EX. U.G. CABLE TV & PEDESTAL
EX. U.G. COMMUNICATION LINE, PEDESTAL & MANHOLE
EX. U.G. ELEC. MANHOLE, METER & HANDHOLE
EX. GAS LINE
EX. GAS VALVE & GAS LINE MARKER
EX. TRANSFORMER & IRRIGATION VALVE
EX. WATER MAIN
EX. HYDRANT, GATE VALVE & POST INDICATOR VALVE
EX. WATER VALVE BOX & SHUTOFF
EX. SANITARY SEWER
EX. SANITARY CLEANOUT & MANHOLE
EX. COMBINED SEWER MANHOLE
EX. STORM SEWER
EX. CLEANOUT & MANHOLE
EX. SQUARE, ROUND, & BEEHIVE CATCH BASIN
EX. YARD DRAIN & ROOF DRAIN
EX. UNIDENTIFIED STRUCTURE
EX. MAILBOX, SIGN & LIGHTPOLE
EX. FENCE
EX. GUARD RAIL
EX. SPOT ELEVATION
EX. CONTOUR
EX. WETLAND
IRON FOUND / SET
NAIL FOUND / NAIL & CAP SET
BRASS PLUG SET
MONUMENT FOUND / SET
SECTION CORNER FOUND
RECORDED / MEASURED / CALCULATED

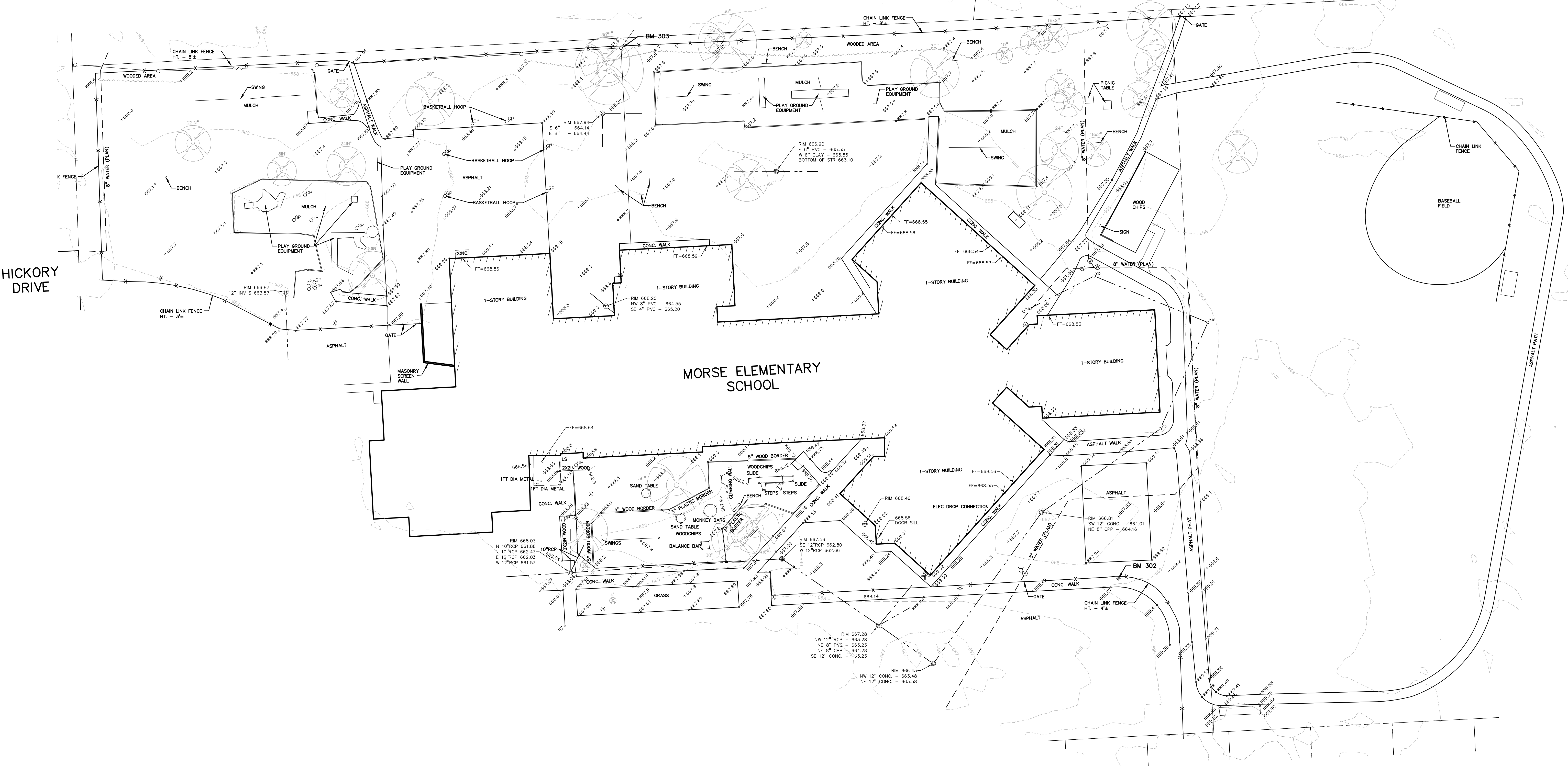
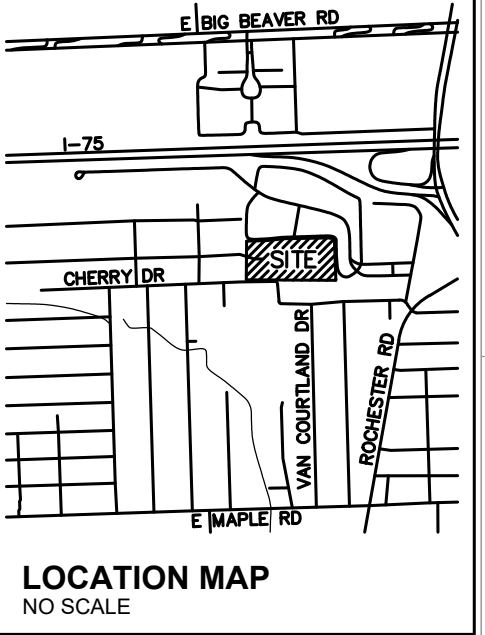
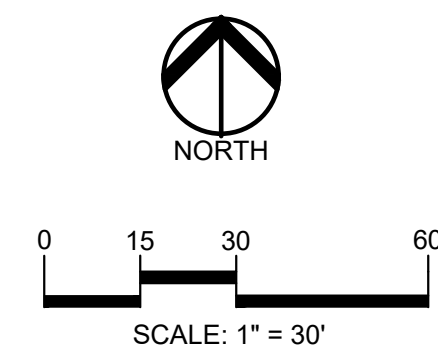

Drawing File: S:\PROJECTS\2023\22-093B\22093B\CONSTRUCTION\A\TOPOG\22093B\CE-5.1.01A_TROY_MORSE_23-11-23.dwg
Nov 09, 2023 - 5:09pm

REGISTRATION SEAL

CONSULTANT

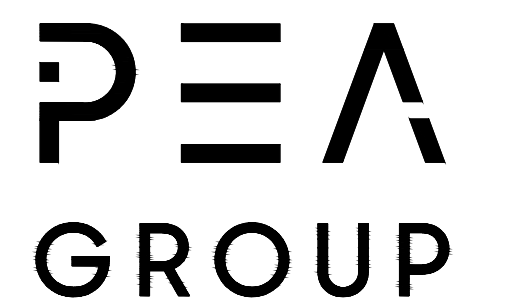

t: 844.813.2949
www.peagroup.com

PROJECT TITLE

**Morse
Elementary School**
475 CHERRY AVENUE
**Playground Renovation
Bid Package No.01A**

Troy School District
Troy, Michigan

DRAWING TITLE
Demolition Plan

ISSUE DATES

11-9-2023 CONSTRUCTION DOCUMENTS

DATE ISSUED FOR:

DRAWN WR

CHECKED RR

APPROVED TD

PROJECT NO.

22093B

DRAWING NO.

CE-5.2.0

DEMOLITION LEGEND:

ITEM TO BE PROTECTED	
ITEM TO BE REMOVED	
CURB/FENCE REMOVAL	
CONCRETE PAVEMENT AND SIDEWALK REMOVAL	
AREA OR ITEMS TO BE REMOVED	
UTILITY REMOVAL	
ABANDON UTILITY	
ASPHALT REMOVAL	
TREE REMOVAL	
SAWCUT LINE	

NOTE:
CONTRACTOR TO VERIFY ALL QUANTITIES SHOWN ON THE PLANS. ANY DEVIATIONS TO THE PLAN QUANTITIES SHALL BE BROUGHT TO THE ATTENTION OF THE SCHOOL DISTRICT AND PEA GROUP. IN WRITING PER THE BID PACKAGE, FOR VERIFICATION PRIOR TO BIDDING.

- GENERAL DEMOLITION NOTES:**
- THESE NOTES APPLY TO ALL CONSTRUCTION ACTIVITIES ON THIS PROJECT:
- ALL MATERIAL TO BE REMOVED, WHETHER SPECIFICALLY NOTED IN THE PLANS OR NOT, SHALL BE REMOVED FROM THE SITE BY THE CONTRACTOR AND DISPOSED OF OFF-SITE IN A LEGAL MANNER. NO ON-SITE BURY OR BURN PITS SHALL BE ALLOWED.
 - ALL DEMOLITION WORK SHALL CONFORM TO ALL LOCAL CODES AND ORDINANCES.
 - STAGING/PHASING OF DEMOLITION AND CONSTRUCTION IS TO BE COORDINATED WITH THE OWNER AND THE CONTRACTOR PRIOR TO CONSTRUCTION.
 - SPECIFIC DEMOLITION ITEMS HAVE BEEN INDICATED ON THE PLANS AS A GUIDE TO THE GENERAL SCOPE OF THE WORK. IT IS THE INTENT THAT THESE ITEMS SHALL BE COMPLETELY REMOVED BY THE CONTRACTOR ABOVE AND BELOW GROUND, UNLESS SPECIFICALLY NOTED OTHERWISE, AND THAT DEMOLITION WILL INCLUDE BUT WILL NOT NECESSARILY BE LIMITED TO THESE ITEMS. CONTRACTOR SHALL VISIT SITE TO VERIFY EXISTING CONDITIONS AND EXTENTS OF THE DEMOLITION THAT WILL BE REQUIRED PRIOR TO SUBMITTING A BID.
 - REMOVE ALL STRUCTURES DESIGNATED FOR REMOVAL ACCORDING TO THE DEMOLITION PLAN. THIS INCLUDES FOUNDATIONS, FOOTINGS, FOUNDATION WALLS, FLOOR SLABS, UNDERGROUND UTILITIES, CONCRETE, ASPHALT, TREES, ETC.
 - THE CONTRACTOR SHALL, AS A MINIMUM, PROVIDE TREE PROTECTION FENCING AROUND EXISTING TREES TO BE SAVED THAT ARE WITHIN 15 FEET OF CONSTRUCTION ACTIVITIES AND AS INDICATED IN THE PLANS OR PER LOCAL AGENCY REQUIREMENTS.
 - THE CONTRACTOR SHALL BE RESPONSIBLE FOR CLEAN UP, NOISE, DUST CONTROL, STREET SWEEPING AND HOURS OF OPERATION IN ACCORDANCE WITH THE LOCAL CODES.
 - THE CONTRACTOR SHALL PROVIDE ALL NECESSARY BARRICADES, SIGNAGE, MARKINGS, LIGHTS AND OTHER TRAFFIC CONTROL DEVICES TO PROTECT THE WORK ZONE AND SAFELY MAINTAIN TRAFFIC PER AGENCY REQUIREMENTS AND IN ACCORDANCE WITH THE LATEST EDITION OF THE STATE MANUAL OF UNIFORM TRAFFIC CONTROL DEVICES.
 - THE CONTRACTOR SHALL CONTACT THE APPROPRIATE UTILITY COMPANIES TO CONFIRM THAT UTILITY LEADS HAVE BEEN TAKEN OUT OF SERVICE PRIOR TO DEMOLITION.
 - ALL BUILDING GAS LEADS, METERS AND ASSOCIATED EQUIPMENT SHALL BE REMOVED AS SHOWN ON THE PLANS. COORDINATE ALL ASSOCIATED WORK WITH THE APPROPRIATE UTILITY COMPANY.
 - REMOVE ALL OVERHEAD AND UNDERGROUND ELECTRICAL LINES WITHIN THE AREA OF CONSTRUCTION AS SHOWN ON THE PLANS. COORDINATE SHUTDOWNS AND REMOVALS WITH ELECTRICAL SERVICE PROVIDER OR THE APPROPRIATE UTILITY COMPANY. (NOTE: PHONE AND CABLE T.V. SERVICES MAY ALSO BE LOCATED ON OVERHEAD LINES.)
 - THE CONTRACTOR IS RESPONSIBLE FOR THE REMOVAL AND REPLACEMENT OF SIGNS AND SUPPORTS WITHIN THE WORK AREA, AS NECESSARY TO FACILITATE CONSTRUCTION. SIGNS SHALL BE PROTECTED OR STOCKPILED FOR REUSE AS SPECIFIED IN THE PLANS OR AS REQUIRED BY THE AGENCY OF JURISDICTION. THE CONTRACTOR SHALL REPLACE ANY DAMAGED SIGNS AND SUPPORTS AT NO ADDITIONAL COST TO THE OWNER.
 - THE CONTRACTOR SHALL NOTIFY THE APPROPRIATE 811/ONE CALL UTILITY LOCATING CENTER, THE CITY ENGINEER AND/OR THE AUTHORITY HAVING JURISDICTION 3 BUSINESS DAYS PRIOR TO THE BEGINNING OF CONSTRUCTION.

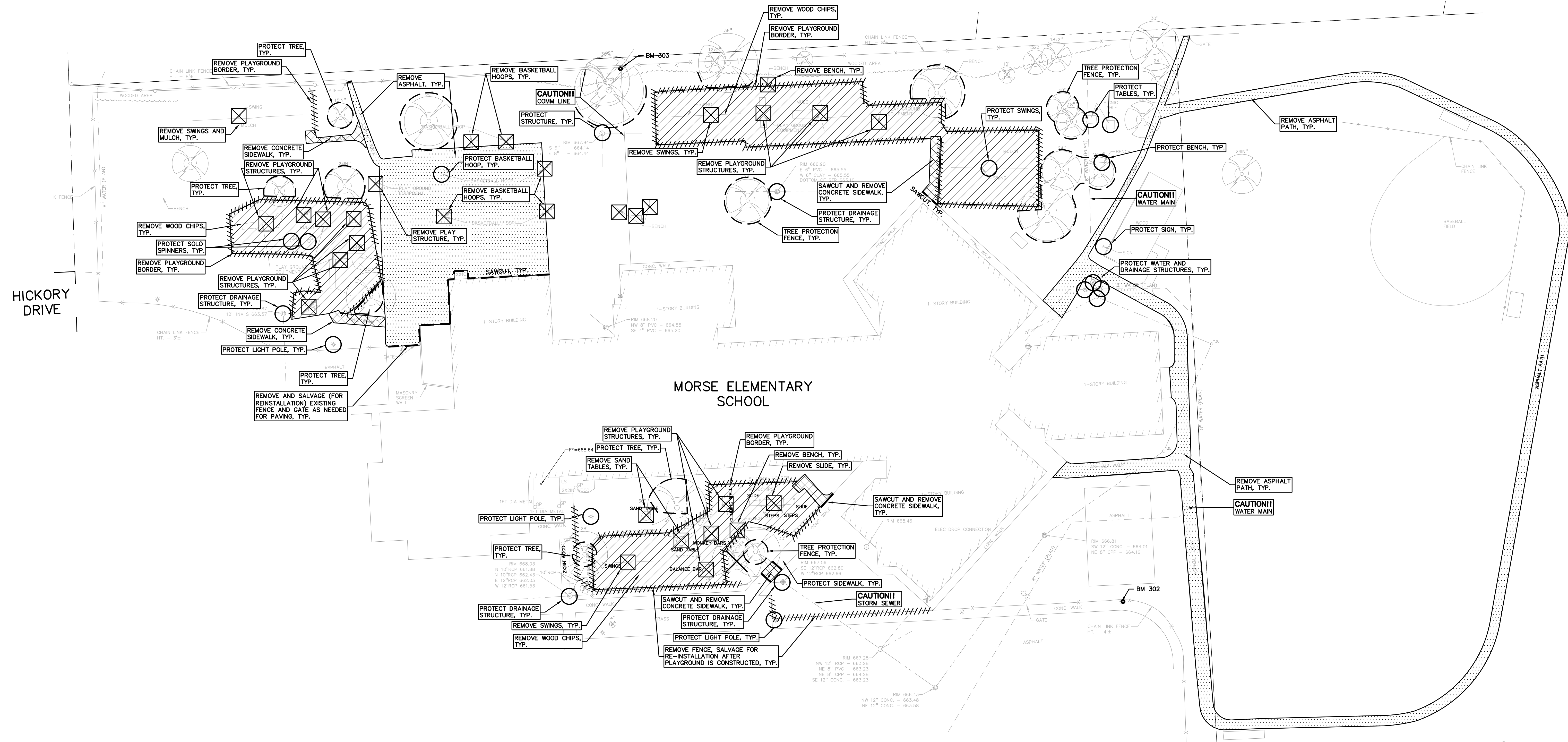



TMP ARCHITECTURE INC
 1591 WEST SQUARE LAKE ROAD
 BLOOMFIELD HILLS - MICHIGAN - 48302
 PH - 248.838.6962 FX - 248.338.0223
 EM - INFO@TMP-ARCHITECTURE.COM

REGISTRATION SEAL

CONSULTANT

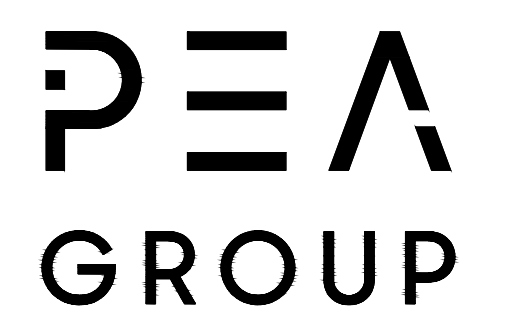

t: 844.813.2949
 www.peagroup.com

PROJECT TITLE

Morse Elementary School
 475 CHERRY AVENUE

Playground Renovation Bid Package No.01A

Troy School District
 Troy, Michigan

DRAWING TITLE
Dimension & Paving Plan

ISSUE DATES

11-9-2023 CONSTRUCTION DOCUMENTS

DATE ISSUED FOR:

DRAWN WR

CHECKED RR

APPROVED TD

PROJECT NO.

22093B

DRAWING NO.

CE-5.3.0

SUBGRADE UNDERCUTTING NOTES:

1. TO MINIMIZE SUBGRADE INSTABILITY AND UNDERCUTS, THE SUBGRADE SHALL NOT BE LEFT EXPOSED TO PRECIPITATION AND CONSTRUCTION OPERATIONS AND SHOULD BE PERFORMED DURING THE WARMER MONTHS TO ENSURE DRY, WARM, WEATHER. ADDITIONALLY, THE SUBGRADE MAY BECOME UNSTABLE UNDER REPEATED LOADING OF CONSTRUCTION TRAFFIC; THEREFORE, CONSTRUCTION EQUIPMENT SHOULD BE LIMITED ON THE EXPOSED SUBGRADE.
2. SUBGRADE UNDERCUT SHALL BE EVALUATED BY A QUALIFIED ENGINEERING TECHNICIAN TO DETERMINE IF SUBGRADE STABILIZATION IS NECESSARY. UNDERCUT EXCAVATIONS SHALL BE BACKFILLED WITH MDOT 21AA DENSE GRADED AGGREGATE PLACED IN AN ENGINEERED MANNER. LIFT THICKNESS SHALL NOT EXCEED 9 INCHES. THE USE OF TRI-AXIAL GEOTEXTILE MAY BE USED TO REDUCE UNDERCUT DEPTHS, AS APPROVED BY THE DISTRICT AND PER THE UNIT PRICE PROVIDED WITH THE CONTRACTORS BID.
3. THE QUANTITY FOR SUBGRADE UNDERCUT FOR EACH SITE SHALL BE INCLUDED IN THE BASE BID. THIS ITEM IS CONSIDERED AN ALLOWANCE AND FINAL PAYMENT WILL BE BASED ON THE ACTUAL VOLUME OF COMPACTED IN PLACE STONE PER THE UNIT PRICE PROVIDED IN THE BID PACKAGE.
4. ALL ENGINEERED FILL SHALL BE COMPACTED TO A DENSITY OF AT LEAST 95 PERCENT OF THE MAXIMUM DENSITY DETERMINED BY THE MODIFIED PROCTOR (ASTM D1557) METHOD OF TESTING. ALL ENGINEERED FILL MATERIAL SHALL BE PLACED AND COMPACTED AT APPROXIMATELY THE OPTIMUM MOISTURE CONTENT. FROZEN MATERIAL SHALL NOT BE USED AS FILL, NOR SHOULD FILL BE PLACED ON A FROZEN SUBGRADE.
5. SUBGRADE UNDERCUT DRAIN TILE SHALL BE EVALUATED BY A QUALIFIED ENGINEERING TECHNICIAN TO DETERMINE IF SUBGRADE STABILIZATION IS NECESSARY. DRAIN TILE SHALL BE PLACED WITHIN ANY UNDERCUT AREA AND CONNECTED TO THE CLOSEST CATCH BASIN TO PREVENT GROUNDWATER FROM POOLING WITHIN THE GRANULAR SOILS IN UNDERCUTS AND CREATING "BATHTUBS" IN THE COHESIVE SOILS.
6. THE QUANTITY FOR SUBGRADE UNDERCUT DRAIN TILE (4") FOR EACH SITE SHALL BE INCLUDED IN THE BASE BID. THIS ITEM IS CONSIDERED AN ALLOWANCE AND FINAL PAYMENT WILL BE BASED ON THE ACTUAL FOOTAGE OF COMPACTED IN PLACE STONE PER THE UNIT PRICE PROVIDED IN THE BID PACKAGE.

NOTES:

1. CONTRACTOR TO VERIFY ALL QUANTITIES SHOWN ON THE PLANS. ANY DEVIATIONS TO THE PLAN QUANTITIES SHALL BE BROUGHT TO THE ATTENTION OF THE SCHOOL DISTRICT AND PEA GROUP IN WRITING PER THE BID PACKAGE, FOR VERIFICATION PRIOR TO BIDDING.
2. ALL DIMENSIONS SHOWN ARE TO BACK OF CURB, FACE OF SIDEWALK, CENTER OF MANHOLE/CATCH BASIN UNLESS OTHERWISE NOTED.
3. DOWEL INTO EXISTING CURB AND CUTTER 9" WITH EPOXY COATED #4 BAR CONTINUOUS BETWEEN EXISTING AND PROPOSED CURBING.
4. REFER TO NOTES AND DETAILS SHEET FOR PAVING DETAILS.
5. CONTRACTOR TO FIELD VERIFY ALL UNDERGROUND UTILITIES PRIOR TO CONSTRUCTION INCLUDING BUT NOT LIMITED TO: SITE LIGHTING, FIBER LINES, ETC.
6. CONTRACTOR TO REMOVE AND REPLACE SIGNS AND POSTS PER DETAILS ON SHEET C-4.0. ALL SIGNS AND ANY POSTS IN GOOD CONDITION SHALL BE RETURNED TO THE OWNER. ALL POSTS DAMAGED OR OTHERWISE NOT IN USEABLE CONDITION, SHALL BE DISPOSED OF AT NO ADDITIONAL COST TO THE OWNER.
7. FOR THE TWO (2) CATCH BASINS, LOCATED IN THE WORK AREA; BIDDERS ARE TO INCLUDE RECONSTRUCTION OF THESE STRUCTURES (GREATER THAN 12-INCHES IN DEPTH FROM THE RIM ELEVATION OF REPAIR WORK) IN THE BASE BID. THE SUCCESSFUL BIDDER WILL BE PAID FOR REPAIRING EACH STRUCTURE BASED ON THE ACTUAL DEPTH OF REPAIR WITH EITHER STRUCTURAL ADJUSTMENT (WITHIN TOP 12-INCHES OF RIM ELEVATION) OR STRUCTURAL RECONSTRUCTION (GREATER THAN 12-INCHES IN DEPTH) PER THE UNIT PRICES PROVIDED IN THE BID PACKAGE AND THE SCOPE OF WORK DETERMINED AND APPROVED PRIOR TO THE WORK COMMENCING. REPLASTERING OF THE ENTIRE STRUCTURE SHALL BE INCLUDED IN THE UNIT PRICE FOR BOTH STRUCTURAL ADJUSTMENT AND STRUCTURAL RECONSTRUCTION.

LEGEND:

- CONCRETE PAVEMENT
- ASPHALT PAVEMENT
- GRAVEL
- WETLAND
- CONCRETE CURB AND GUTTER
- REVERSE GUTTER PAN
- SETBACK LINE
- SIGN
- LIGHTPOLE
- FENCE
- GUARD RAIL



SCALE: 1" = 30'

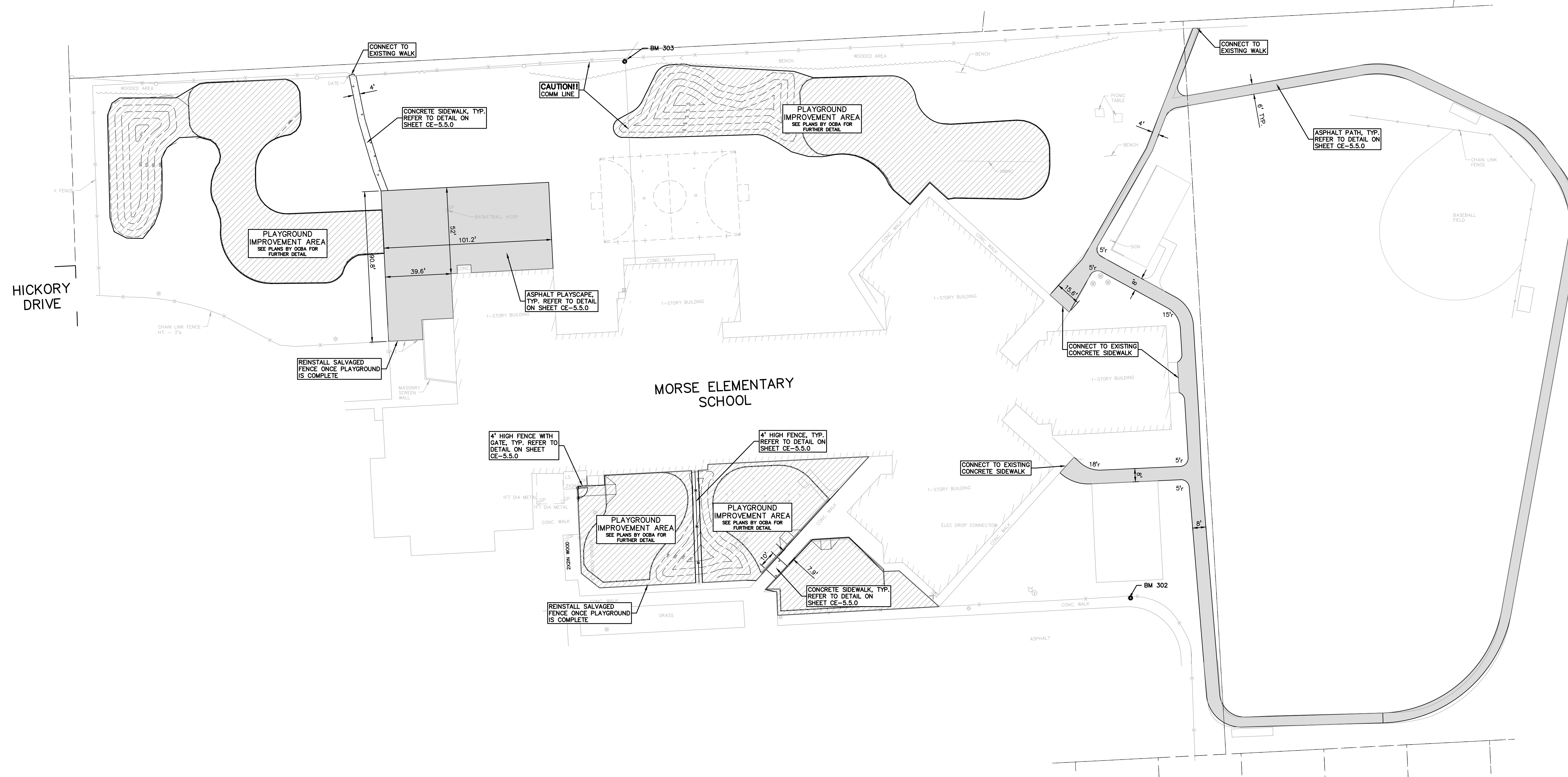

Drawing File: S:\PROJECTS\2023\21-001 7807 SCHOOL 2022 2020\DWG\CONSTRUCTION\PEA\PROJECTS\MORSE\0-5.3.1 LAYOUT MORSE 21-022.dwg
 Nov 09, 2023 - 5:10pm

SEQUENCE OF CONSTRUCTION:

START DAY	END DAY	DESCRIPTION
1	2	INSTALL TEMPORARY SOIL EROSION CONTROL MEASURES, SILT FENCES, INLET PROTECTION, ETC. AS NECESSARY.
1	90	MAINTAIN A 25' BUFFER OF VEGETATION AROUND PERIMETER OF SITE WHERE POSSIBLE.
1	5	STRIP AND STOCKPILE TOPSOIL AS REQUIRED RESTORATION. ALL STOCKPILES MUST BE GRADED AND SEEDED.
5	15	REMOVE ALL PAVEMENT, CURB, UTILITIES, ETC. AS REQUIRED TO INSTALL THE PROPOSED WORK AS SHOWN ON THE TOPOGRAPHIC SURVEY AND DEMOLITION PLAN.
10	15	DISPOSE OF ALL EXCESS/UNSUITABLE MATERIALS OFF SITE IN A LEGAL MANNER. NO ON-SITE BURN OR BURY PITS ALLOWED.
30	40	ROUGH GRADE SITE. SEED AND MULCH BLANKETS MUST BE INSTALLED AS SHOWN WITHIN 5 DAYS OF FINAL GRADE. REPAIR AND/OR RE-INSTALL ANY TEMPORARY SOIL EROSION CONTROL MEASURES THAT WERE DAMAGED DURING GRADING OPERATIONS.
45	90	TEMPORARY SEEDING MUST BE PROVIDED IN AREAS NOT TO BE WORKED ON FOR 15 DAYS OR LONGER.
50	80	FINE GRADE SITE AND PREPARE FOR SITE PAVING OPERATIONS.
50	80	INSTALL ALL PAVEMENT, SIDEWALKS, CURBING AS PROPOSED. IF PERMANENT LANDSCAPING IS NOT TO BE INSTALLED SOON AFTER PAVING IS COMPLETE, ALL AREAS WITHIN 20 FEET OF BACK OF CURB MUST BE TEMPORARILY SEEDED. REPAIR INLET PROTECTION, SILT FENCE AND ANY OTHER DAMAGED SOIL EROSION CONTROL MEASURES AS NECESSARY.
80	89	FINAL GRADE, REDISTRIBUTE STOCKPILED TOPSOIL, ESTABLISH VEGETATION AND INSTALL ALL PERMANENT LANDSCAPING IN ALL DISTURBED AREAS NOT BUILT.
88	90	CLEAN PAVEMENT AND REMOVE ALL TEMPORARY SOIL EROSION CONTROL MEASURES. RE-ESTABLISH VEGETATION AS REQUIRED.
90	90	REMOVE SEDIMENTATION CONTROLS ONCE ENTIRE SITE HAS BEEN PERMANENTLY STABILIZED.

NOTE:

- PER THE SOIL EROSION AND SEDIMENTATION CONTROL SEQUENCE OF CONSTRUCTION NOTES THE SUCCESSFUL BIDDER TO CLEAN THE STORM SEWER, THIS CLEANING SHALL INCLUDE CLEANING OUT THE STRUCTURES AND ENTIRE SEWER RUNS BETWEEN STRUCTURES USING HYDRAULICALLY PROPULSED, HIGH-VELOCITY JET, OR MECHANICALLY POWERED EQUIPMENT. SELECTION OF THE EQUIPMENT USED SHALL BE BASED ON THE CONDITIONS OF LINES AT THE TIME THE WORK COMMENCES. THE EQUIPMENT AND METHODS SELECTED SHALL BE SATISFACTORY TO THE SCHOOL DISTRICT'S REPRESENTATIVE. THE EQUIPMENT SHALL BE CAPABLE OF REMOVING DIRT, GREASE, ROCKS, SAND, AND OTHER MATERIALS AND OBSTRUCTIONS FROM THE SEWER LINES AND MANHOLES. IF CLEANING OF AN ENTIRE SECTION CANNOT BE SUCCESSFULLY PERFORMED FROM ONE MANHOLE, THE EQUIPMENT SHALL BE SET UP ON THE OTHER MANHOLE AND CLEANING AGAIN ATTEMPTED. IF AGAIN, SUCCESSFUL CLEANING CANNOT BE PERFORMED OR THE EQUIPMENT FAILS TO TRAVERSE THE ENTIRE MANHOLE SECTION, IT WILL BE ASSUMED THAT A MAJOR BLOCKAGE EXISTS AND THE CLEANING EFFORT SHALL BE ABANDONED.
- PER THE PROJECT SPECIFICATIONS, PRIOR TO THE PLACEMENT OF TOPSOIL, THE SUCCESSFUL BIDDER TO SCHEDULE AN INSPECTION BY THE SCHOOL DISTRICT OR PEA GROUP TO CONFIRM THAT THE GRADE IS AT THE PROPER ELEVATION WHERE THE MINIMUM DEPTH OF TOPSOIL CAN BE PLACED THROUGHOUT THE AREA.
- CONTRACTOR TO FIELD VERIFY ALL UNDERGROUND UTILITIES PRIOR TO CONSTRUCTION INCLUDING BUT NOT LIMITED TO: SITE LIGHTING, FIBER LINES, ETC.

SOIL EROSION MAINTENANCE SCHEDULE AND NOTES:

- THE SOIL EROSION CONTROLS WILL BE MAINTAINED WEEKLY AND AFTER EVERY STORM EVENT BY:
 ROB CARSON
 TROY SCHOOL DISTRICT
 1140 RANKIN
 TROY, OAKLAND COUNTY, MICHIGAN
 249-923-4697
- IF ANY DAMAGE HAS OCCURRED AS A RESULT OF STORM WATER DISCHARGE FROM THE SITE, THE FOLLOWING STEPS SHALL BE IMPLEMENTED.
- ANY DEBRIS OR DIRT ON ANY PAVED AREA RESULTING FROM CONSTRUCTION TRAFFIC SHALL BE CLEANED IN A PROMPT MANNER BY THE CONTRACTOR. THE CONSTRUCTION DRIVE SHALL BE CLEANED AT THE END OF EACH DAY.
- ALL DIRT AND MUD TRACKED ONTO PAVED AREAS SHALL BE REMOVED BY THE CONTRACTOR DAILY BY SCRAPING. STREET SWEEPING IS REQUIRED WEEKLY.
- SILT FENCE MAINTENANCE SHALL INCLUDE THE REMOVAL OF ANY BUILT UP SEDIMENT WHEN THE SEDIMENT HEIGHT ACCUMULATES TO 1/3 TO 1/2 OF THE HEIGHT OF THE FENCE. THE CONTRACTOR IS RESPONSIBLE TO REMOVE, REPLACE, RETRENCH OR REBACKFILL THE SILTATION FENCE SHOULD IT FALL OR BE DAMAGED DURING CONSTRUCTION.
- INLET FILTER MAINTENANCE SHALL INCLUDE THE REMOVAL OF ANY ACCUMULATED SILT OR OTHER DEBRIS. THE REMOVAL OF SILT SHOULD BE WITH THE USE OF A STIFF BRISTLE BROOM OR SQUARE POINT SHOVEL. IF INLET FILTERS CAN NOT BE CLEANED OR ARE DAMAGED, THEN THE FABRIC MUST BE REPLACED.
- CONTRACTOR TO PROVIDE WATER TRUCK TO WATER DOWN THE SITE ON A DAILY BASIS AS REQUIRED TO MAINTAIN DUST CONTROL.
- IF HIGH GROUNDWATER IS ANTICIPATED OR ENCOUNTERED DURING CONSTRUCTION A DETERMINING PLAN MUST BE SUBMITTED TO THE CITY ENGINEERING DIVISION FOR REVIEW.

GENERAL SITE CONDITIONS:

- ACCORDING TO THE USDA NRCS WEB SOIL SURVEY, THE SITE CONSISTS OF THE FOLLOWING SOIL TYPES:
 56A URBAN LAND-BLUNT-LENEWEE COMPLEX, 0-3 PERCENT SLOPES
 62B URBAN LAND-SPINX COMPLEX, 0-8 PERCENT SLOPES
 63A URBAN LAND-THEFORD COMPLEX, 0-3 PERCENT SLOPES
- TOTAL DISTURBED AREA = ±2.0 ACRES

SOIL EROSION AND SEDIMENTATION CONTROL SEQUENCE OF CONSTRUCTION

- SEE OAKLAND COUNTY W.R.C. SOIL EROSION AND SEDIMENTATION CONTROL DETAILS SHEET FOR ALL SOIL EROSION CONTROL RELATED DETAILS.
- PLACE SILT FENCE & INSTALL INLET FILTERS ON EXISTING STORM SEWER STRUCTURES, ACCORDING TO PLANS.
- INSTALL TEMPORARY CRUSHED CONCRETE ACCESS DRIVE AT ALL CONSTRUCTION ENTRANCES. (80"x24"x8" W/MINIMUM OF 1"-3" CRUSHED CONCRETE - NO FINES).
- REMOVE CURB, PAVEMENT, TREES, ETC. AS DIRECTED ON THE DEMOLITION PLAN.
- STRIP AND STOCKPILE TOPSOIL FOR RESTORATION REQUIREMENTS.
- DISPOSE OF ALL EXCESS, UNSUITABLE MATERIALS OFF SITE IN A LEGAL MANNER. NO BURN OR BURY PITS ALLOWED.
- UNUSABLE MATERIALS CONSIST OF, BUT ARE NOT NECESSARILY LIMITED TO THE FOLLOWING: CONCRETE, ASPHALT, TREES, BRUSH, STUMPS, ROOTS, OR OTHER MISCELLANEOUS DEBRIS OR TRASH.
- MASS GRADE THE SITE IN ACCORDANCE WITH THE PLANS.
- INSTALL HYDROSEED AS SHOWN ON THE PLAN WITHIN 5 DAYS OF COMPLETION OF MASS GRADING OR WHENEVER DISTURBED AREAS WILL REMAIN UNCHANGED FOR 30 DAYS OR GREATER. MINIMUM 3"-4" TOPSOIL WILL BE USED WHERE VEGETATION IS REQUIRED.
- COMPLETE ROUGH GRADING OF SITE. PLACE INLET FILTERS AT ALL INLETS AND CATCH BASINS, AS SHOWN.
- FINISH GRADE AND PAVE SITE AS PROPOSED TO DRAIN TO STORM SEWER SYSTEM. REPAIR INLET FILTERS AS REQUIRED.
- APPLY TOPSOIL, HYDROSEED TO ALL DISTURBED AREAS UPON COMPLETION OF GRADING. THE CONTRACTOR SHALL STAGE CONSTRUCTION ACTIVITIES IN ORDER TO MINIMIZE THE EXPOSURE OF UNSTABILIZED AREAS.
- CLEAN PAVEMENT AND STORM SEWERS. REMOVE SILT FENCE AND TREE PROTECTION FENCE, AND INLET FILTERS ONCE VEGETATION HAS BEEN ESTABLISHED.
- ALL DIRT AND MUD TRACKED ONTO PUBLIC ROADS SHALL BE REMOVED DAILY.
- STREET CATCH BASINS TO BE PERIODICALLY CLEANED AND FILTER CLOTH CHANGED AND MAINTAINED.

EARTHWORK BALANCING NOTE:

THE CONTRACTOR SHALL BE RESPONSIBLE FOR IMPORTING OR EXPORTING ALL MATERIALS AS REQUIRED TO PROPERLY GRADE THIS PROJECT TO THE FINISHED ELEVATIONS SHOWN ON THE APPROVED PLANS. THE CONTRACTOR SHALL MAKE THEIR OWN DETERMINATION OF CUT AND FILL QUANTITIES AND ALLOW FOR REMOVAL OF EXCESS OR IMPORTATION OF ADDITIONAL MATERIAL AT NO ADDITIONAL COST TO THE OWNER.

PREMIUM TRENCH BACKFILL NOTE:

ALL UTILITIES UNDER PAVEMENT OR WITHIN 3' OF THE EDGE OF PAVEMENT (OR WITHIN THE 45° LINE OF INFLUENCE OF PAVEMENT) SHALL HAVE M.D.O.T. CLASS II GRANULAR BACKFILL COMPACTED TO 95% MAX. DRY DENSITY (ASTM D-1557).

GRADING LEGEND:

- EXISTING SPOT ELEVATION
- PROPOSED SPOT ELEVATION
- TYPICALLY TOP OF PAVEMENT IN PAVED AREAS, GUTTER GRADE IN CURB LINES
- EXISTING CONTOUR
- PROPOSED CONTOUR
- PROPOSED REVERSE GUTTER PAN
- PROPOSED RIDGE LINE
- PROPOSED SWALE/DITCH
- ABBREVIATIONS
- TIC = TOP OF CURB
- TP = TOP OF PAVEMENT
- TIS = TOP OF SIDEWALK
- TIW = TOP OF WALL
- G = GUTTER GRADE
- FG = FINISH GRADE
- RM = RIM ELEVATION
- BW = BOTTOM OF WALL

SYMBOLS: EROSION CONTROL:

- (SP-2) SILT FENCE
- (SI-2A) SLOPE INLET FILTER
- (SI-3) RYOB INLET FILTER
- (E-9) EROSION CONTROL BLANKET
- LAWN RESTORATION

REFER TO CITY OF TROY SOIL EROSION AND SEDIMENTATION CONTROL DETAILS SHEET FOR ALL DEVICE DETAILS.

UTILITY LEGEND:

- EX. OH. ELEC. POLE & GUY WIRE
- EX. U.G. CABLE TV & PEDESTAL
- EX. U.G. COMMUNICATION LINE, PEDESTAL & MANHOLE
- EX. U.G. ELEC. MANHOLE, METER & HANDHOLE
- EX. GAS LINE
- EX. GAS VALVE & GAS LINE MARKER
- EX. TRANSFORMER & IRRIGATION VALVE
- EX. WATER MAIN
- EX. HYDRANT, GATE VALVE & POST INDICATOR VALVE
- EX. WATER VALVE BOX & SHUTOFF
- EX. SANITARY SEWER
- EX. SANITARY CLEANOUT & MANHOLE
- EX. COMBINED SEWER MANHOLE
- EX. STORM SEWER
- EX. CLEANOUT & MANHOLE
- EX. SQUARE, ROUND, & BEEHIVE CATCH BASIN
- EX. YARD DRAIN & ROOF DRAIN
- EX. UNIDENTIFIED STRUCTURE
- PROPOSED HYDRANT AND GATE VALVE
- PROPOSED TAPPING SLEEVE, VALVE & WELL
- PROPOSED POST INDICATOR VALVE
- PROPOSED SANITARY SEWER
- PROPOSED SANITARY CLEANOUT & MANHOLE
- PROPOSED STORM SEWER
- PROPOSED STORM SEWER CLEANOUT & MANHOLE
- PROPOSED CATCH BASIN, INLET & YARD DRAIN

BENCHMARKS:
(GPS DERIVED - NAVD83)

BM 302 - MAG NAIL IN THE EAST FACE OF CONCRETE LIGHT POLE BASE 1105' SW FROM SE BUILDING CORNER ELEVATION: 669.42
BM 303 - BENCH TIE IN THE SOUTH FACE OF THE EASTERLY MOST POWER POLE ALONG THE NORTH PROPERTY LINE. ELEVATION: 669.36

STORM STRUCTURES		STORM STRUCTURES	
CB	8	(4' DIA./0' SUMP)	RIM = 667.60 6" S 664.63
STUB	2	6" S	664.00
STUB	4	6" SW	665.06
STUB	5	6" SE	665.20
STUB	9	6" N	664.75

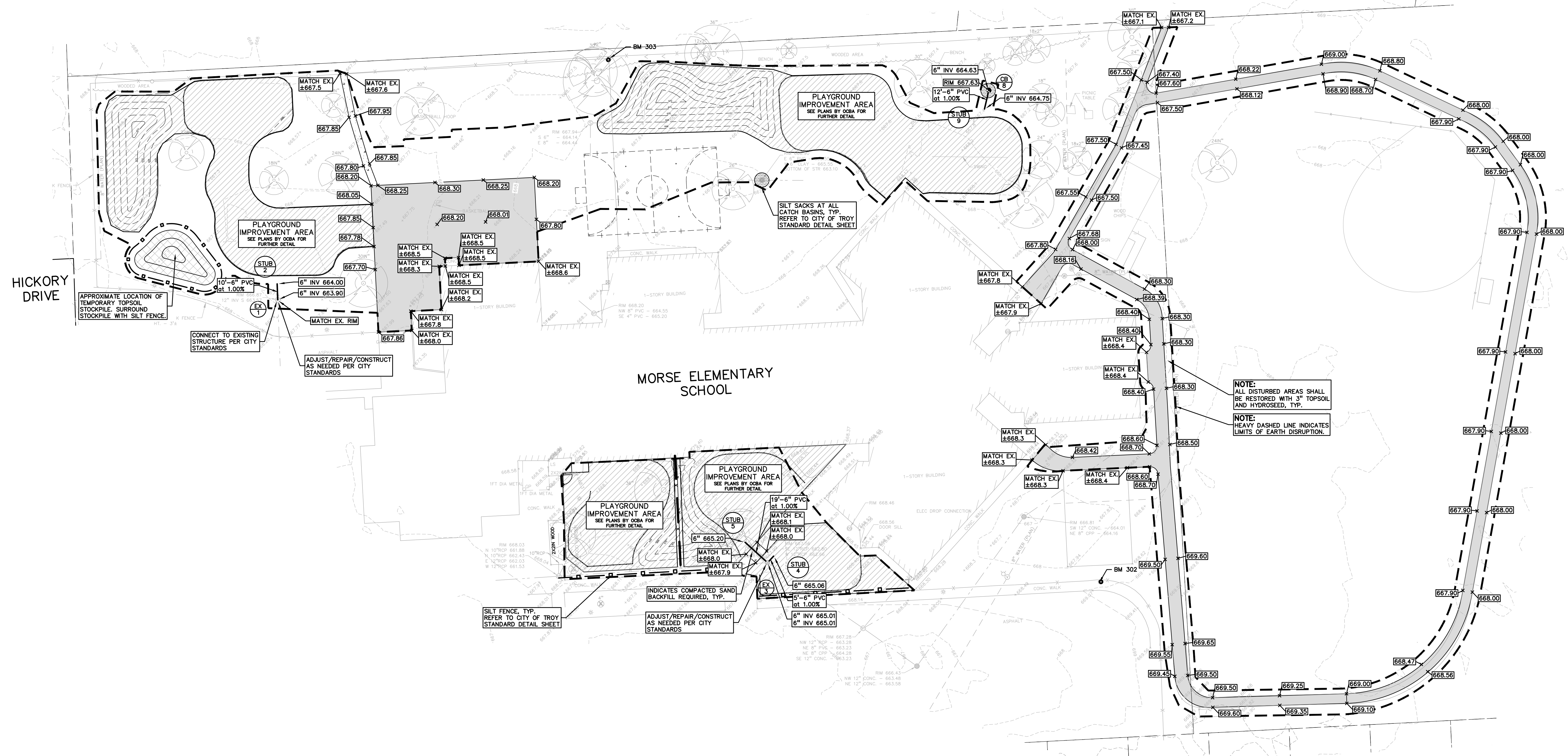
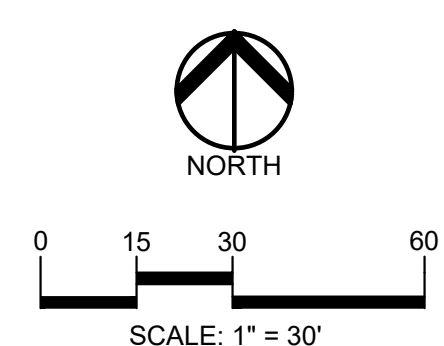

TMP ARCHITECTURE INC
 1591 WEST SQUARE LAKE ROAD
 BLOOMFIELD HILLS, MICHIGAN 48302
 PH - 248.338.6962 FX - 248.338.0223
 EM - INFO@TMP-ARCHITECTURE.COM

REGISTRATION SEAL

CONSULTANT

PEA GROUP
 t: 844.813.2949
 www.peagroup.com

PROJECT TITLE
Morse Elementary School
 475 CHERRY AVENUE
Playground Renovation Bid Package No.01A

Troy School District
 Troy, Michigan

DRAWING TITLE
Grading, Utility & Soil Erosion Control Plan

ISSUE DATES

NO.	DATE	DESCRIPTION

PROJECT NO.
22093B

DRAWING NO.
CE-5.4.0

Drawing File: S:\PROJECTS\2022\2022-09-01\TROY_SCHOOL_2022_BID_PACKAGE_NO1A_ARCHITECTURE\CE-5.4.0.dwg
 Nov 20, 2023 5:51pm

- GENERAL NOTES:**
- THESE NOTES APPLY TO ALL CONSTRUCTION ACTIVITIES ON THIS PROJECT.
1. ALL CONSTRUCTION, WORKMANSHIP AND MATERIALS SHALL BE IN ACCORDANCE WITH CURRENT OSHA, MDOT AND MUNICIPALITY STANDARDS AND REGULATIONS.
 2. THE CONTRACTOR SHALL NOTIFY THE CITY OF TROY ENGINEER AND/OR THE AUTHORITY HAVING JURISDICTION 3 BUSINESS DAYS PRIOR TO THE BEGINNING OF CONSTRUCTION.
 3. THE CONTRACTOR MUST CONTACT THE ENGINEER SHOULD THEY ENCOUNTER ANY DESIGN ISSUES DURING CONSTRUCTION. IF THE CONTRACTOR MAKES DESIGN MODIFICATIONS WITHOUT THE WRITTEN DIRECTION OF THE DESIGN ENGINEER, THE CONTRACTOR DOES SO AT HIS OWN RISK.
 4. ALL NECESSARY PERMITS, TESTING, BONDS AND INSURANCES ETC., SHALL BE PAID FOR BY THE CONTRACTOR. THE OWNER SHALL PAY FOR ALL CITY INSPECTION FEES.
 5. THE CONTRACTOR SHALL NOTIFY THE APPROPRIATE 811/ONE CALL UTILITY LOCATING CENTER, THE CITY ENGINEER AND/OR THE AUTHORITY HAVING JURISDICTION 3 BUSINESS DAYS PRIOR TO THE BEGINNING OF CONSTRUCTION. IF NO NOTIFICATION IS GIVEN AND DAMAGE RESULTS, SAID DAMAGE WILL BE REPAIRED AT SOLE EXPENSE OF THE CONTRACTOR. IF EXISTING UTILITY LINES ARE ENCOUNTERED THAT CONFLICT IN LOCATION WITH NEW CONSTRUCTION, THE CONTRACTOR SHALL NOTIFY THE DESIGN ENGINEER SO THAT THE CONFLICT MAY BE RESOLVED.
 6. CONTRACTOR TO VERIFY THAT THE PLANS AND SPECIFICATIONS ARE THE VERY LATEST PLANS AND SPECIFICATIONS AND FURTHERMORE, VERIFY THAT THESE PLANS AND SPECIFICATIONS HAVE BEEN APPROVED. ALL ITEMS CONSTRUCTED BY THE CONTRACTOR PRIOR TO RECEIVING FINAL APPROVAL, HAVING TO BE ADJUSTED OR RE-DONE, SHALL BE AT THE CONTRACTORS EXPENSE. SHOULD THE CONTRACTOR ENCOUNTER A CONFLICT BETWEEN THESE PLANS AND/OR SPECIFICATIONS, THEY SHALL SEEK CLARIFICATION IN WRITING FROM THE ENGINEER BEFORE COMMENCEMENT OF CONSTRUCTION. FAILURE TO DO SO SHALL BE AT SOLE EXPENSE TO THE CONTRACTOR.
 7. ANY WORK WITHIN THE STREET OR HIGHWAY RIGHTS-OF-WAY SHALL BE PERFORMED IN ACCORDANCE WITH THE REQUIREMENTS OF THE AGENCIES HAVING JURISDICTION AND SHALL NOT BEGUN UNTIL ALL NECESSARY PERMITS HAVE BEEN ISSUED FOR THE WORK.
 8. ALL PROPERTIES OR FACILITIES IN THE SURROUNDING AREAS, PUBLIC OR PRIVATE, DESTROYED OR OTHERWISE DISTURBED DUE TO CONSTRUCTION, SHALL BE REPLACED AND/OR RESTORED TO THE ORIGINAL CONDITION BY THE CONTRACTOR.
 9. THE CONTRACTOR SHALL PROVIDE ALL NECESSARY BARRICADING, SIGNAGE, LIGHTS AND TRAFFIC CONTROL DEVICES TO PROTECT THE WORK AND SAFELY MAINTAIN TRAFFIC IN ACCORDANCE WITH LOCAL REQUIREMENTS AND THE MANUAL OF UNIFORM TRAFFIC CONTROL DEVICES (LATEST EDITION). THE DESIGN ENGINEER, OWNER, CITY OF TROY AND STATE SHALL NOT BE HELD LIABLE FOR ANY CLAIMS RESULTING FROM ACCIDENTS OR DAMAGES CAUSED BY THE CONTRACTORS FAILURE TO COMPLY WITH TRAFFIC AND PUBLIC SAFETY REGULATIONS DURING THE CONSTRUCTION PERIOD.
 10. IT SHALL BE THE RESPONSIBILITY OF THE CONTRACTOR TO ADJUST THE TOP OF ALL EXISTING AND PROPOSED STRUCTURES (MANHOLES, CATCH BASINS, INLETS, GATE WELLS ETC.) WITHIN GRADED AND /OR PAVED AREAS TO FINAL GRADE SHOWN ON THE PLANS. ALL SUCH ADJUSTMENTS SHALL BE INCIDENTAL TO THE JOB AND WILL NOT BE PAID FOR SEPARATELY.

- GENERAL GRADING AND EARTHWORK NOTES:**
- THESE NOTES APPLY TO ALL CONSTRUCTION ACTIVITIES ON THIS PROJECT.
1. CONTRACTOR SHALL FIELD VERIFY ALL EXISTING TREES AND BRUSH AND REMOVE ALL THAT ARE NECESSARY TO GRADE SITE.
 2. ALL GRADES ARE TO TOP OF PAVEMENT UNLESS OTHERWISE NOTED.
 3. THE STAGING OF CONSTRUCTION ACTIVITIES SHALL OCCUR ONLY WITHIN THE SITE BOUNDARIES. ANY CONSTRUCTION ACTIVITIES OUTSIDE OF THE WORK AREA BOUNDARIES SHALL BE AT THE SOLE RESPONSIBILITY AND RISK OF THE CONTRACTOR.
 4. ALL SOIL EROSION AND SEDIMENTATION CONTROL MEASURES SHALL MEET THE REQUIREMENTS OF THE AUTHORIZED PUBLIC AGENCY OF JURISDICTION.
 5. ALL EARTHWORK AND GRADING OPERATIONS SHALL BE PERFORMED IN ACCORDANCE WITH THE PLANS AND SPECIFICATIONS.
 6. REFER TO SOIL EROSION CONTROL PLAN FOR ADDITIONAL SOIL EROSION AND SEDIMENTATION CONTROL MEASURES AND NOTES.
 7. ALL LANDSCAPING IS TO BE COMPLETED BY STALLANTIS.
 8. THE CONTRACTOR SHALL NOTE EXISTING UNDERGROUND UTILITIES WITHIN AND ADJACENT TO THE SITE. BACKFILL FOR EXISTING UTILITY TRENCHES SHALL BE EXAMINED CRITICALLY. ANY TRENCHES FOUND TO HAVE SOFT, UNSTABLE OR UNSUITABLE BACKFILL MATERIAL, IN THE OPINION OF THE THIRD PARTY TESTING COMPANY, THAT ARE TO BE WITHIN THE ZONE OF INFLUENCE OF PROPOSED BUILDINGS OR PAVEMENT SHALL BE COMPLETELY EXCAVATED AND BACKFILLED WITH SUITABLE MATERIAL.
 9. ON-SITE FILL CAN BE USED IF THE SPECIFIED COMPACTION REQUIREMENTS CAN BE ACHIEVED. IF ON-SITE SOIL IS USED, IT SHOULD BE CLEAN AND FREE OF FROZEN SOIL, ORGANICS, OR OTHER DELETERIOUS MATERIALS.
 10. THE FINAL SUBGRADE/EXISTING AGGREGATE BASE SHOULD BE THOROUGHLY PROFFERED USING A FULLY LOADED TANDEM AXLE TRUCK OR FRONT END LOADER UNDER THE OBSERVATION OF A GEOTECHNICAL/PAVEMENT ENGINEER. LOOSE OR YIELDING AREAS THAT CANNOT BE MECHANICALLY STABILIZED SHOULD BE REINFORCED USING GEOTEXTILES OR REMOVED AND REPLACED WITH ENGINEERED FILL OR AS DICTATED BY FIELD CONDITIONS.
 11. THE REMOVAL OF EXISTING SOIL TO GET TO FINAL SUBGRADE ELEVATION SHALL NOT BE CONSIDERED SUBGRADE UNDERCUTTING. IT IS PART OF THE EARTHWORKS TO BALANCE THE SITE AND ESTABLISH THE ELEVATIONS FOR THE PLACEMENT OF THE PROPOSED PAVEMENT ELEVATIONS. THIS SHALL NOT BE PAID FOR SEPARATELY, BUT INCLUDED IN THE EARTHWORKS FOR THE PROJECT.
 12. SUBGRADE UNDERCUTTING, INCLUDING BACKFILLING SHALL BE PERFORMED TO REPLACE MATERIALS SUSCEPTIBLE TO FROST HEAVING AND UNSTABLE SOIL CONDITIONS. ANY EXCAVATIONS THAT MAY BE REQUIRED BELOW THE TOPSOIL IN FILL AREAS OR BELOW SUBGRADE IN CUT AREAS WILL BE CLASSIFIED AS SUBGRADE UNDERCUTTING.
 13. SUBGRADE UNDERCUTTING SHALL BE PERFORMED WHERE NECESSARY AND THE EXCAVATED MATERIAL SHALL BECOME THE PROPERTY OF THE CONTRACTOR. ANY SUBGRADE UNDERCUTTING SHALL BE BACKFILLED AS RECOMMENDED IN THE GEOTECHNICAL ENGINEERING REPORT FOR THE PROJECT.
 14. ANY SUB-GRADE WATERING REQUIRED TO ACHIEVE REQUIRED DENSITY SHALL BE CONSIDERED INCIDENTAL TO THE JOB.

- GENERAL UTILITY NOTES:**
1. ALL WORKMANSHIP AND MATERIALS SHALL BE IN ACCORDANCE WITH THE STANDARDS AND SPECIFICATIONS OF THE CITY OF TROY.
 2. ALL TRENCHES UNDER OR WITHIN THREE (3) FEET OR THE FORTY-FIVE (45) DEGREE ZONE OF INFLUENCE LINE OF EXISTING AND/OR PROPOSED PAVEMENT, BUILDING PAD OR DRIVE APPROACH SHALL BE BACKFILLED WITH SAND COMPACTED TO AT LEAST NINETY-FIVE (95) PERCENT OF MAXIMUM UNIT WEIGHT (ASTM D-1557). ALL OTHER TRENCHES TO BE COMPACTED TO 90% OR BETTER.
 3. WHERE EXISTING MANHOLES OR SEWER PIPE ARE TO BE TAPPED, DRILL HOLES 4" CENTER TO CENTER, AROUND PERIPHERY OF OPENING TO CREATE A PLANE OF WEAKNESS JOINT BEFORE BREAKING SECTION OUT.
 4. THE LOCATIONS AND DIMENSIONS SHOWN ON THE PLANS FOR EXISTING UTILITIES ARE IN ACCORDANCE WITH AVAILABLE INFORMATION WITHOUT UNDERGOING AND MEASURING. THE DESIGN ENGINEER DOES NOT GUARANTEE THE ACCURACY OF THIS INFORMATION OR THAT ALL EXISTING UNDERGROUND FACILITIES ARE SHOWN. CONTRACTOR SHALL FIELD VERIFY UTILITIES.
 5. THE CONTRACTOR SHALL COORDINATE TO ENSURE ALL REQUIRED PIPES, CONDUITS, CABLES AND SLEEVES ARE PROPERLY PLACED FOR THE INSTALLATION OF GAS, ELECTRIC, PHONE, CABLE, IRRIGATION, ETC IN SUCH A MANNER THAT WILL FACILITATE THEIR PROPER INSTALLATION PRIOR TO THE PLACEMENT OF THE PROPOSED PAVEMENT AND LANDSCAPING.
 6. PIPE LENGTHS INDICATED ARE FROM CENTER OF STRUCTURE AND TO END OF SECTION UNLESS NOTED OTHERWISE.
 7. CONTRACTOR SHALL INSPECT ALL EXISTING PUBLIC STORM SEWER, SANITARY SEWER AND WATER MAIN STRUCTURES WITHIN THE LIMITS OF CONSTRUCTION AND WITH THE GOVERNING AGENCY INSPECTOR PRIOR TO ESTABLISHING FINAL GRADE. NOTIFY THE ENGINEER, OWNER/DEVELOPER, AND GOVERNING AGENCY IF STRUCTURES ARE FOUND TO BE STRUCTURALLY UNSOUND AND/OR IN NEED OF REPAIR.
- STORM SEWER NOTES:**
1. ALL STORM SEWER LEADS SHALL BE CONSTRUCTED AT 1.00% MINIMUM SLOPE.
 2. ALL STORM SEWER 10" OR LESS AND/OR LEADS SHALL BE SDR 26.
 3. JOINTS FOR P.V.C. PIPE SHALL BE ELASTOMERIC (RUBBER GASKET) AS SPECIFIED IN A.S.T.M. DESIGNATION D-3212.

- GENERAL BARRIER FREE NOTES:**
- THE FOLLOWING NOTES PROVIDE AN OUTLINE OF SOME OF THE REQUIREMENTS CONTAINED WITHIN THE "STANDARDS FOR ACCESSIBLE DESIGN - AMERICANS WITH DISABILITIES ACT 2010", AND "ACCESSIBLE AND USEABLE BUILDINGS AND FACILITIES", (CO/ANSI A117-2008). THE CONTRACTOR IS RESPONSIBLE FOR ALL OF THE REQUIREMENTS PRESENTED WITHIN THESE DOCUMENTS, WHICH ARE AVAILABLE IN FULL UPON REQUEST.
1. AN ACCESSIBLE ROUTE CONSISTS OF WALK SURFACES, CURB RAMPS AND RAMPS. AT LEAST ONE ACCESSIBLE ROUTE SHALL BE PROVIDED WITHIN THE SITE FROM ACCESSIBLE PARKING SPACES, ACCESSIBLE PASSENGER LOADING ZONES, AND PUBLIC STREETS AND TRANSPORTATION FACILITIES TO STOPPS TO THE BUILDING OR FACILITY ENTRANCE THEY SERVE.
 2. PROFFER-ROLLED/COMPACTED FILL COMPACTED TO PER OF MAX. DRY UNIT WEIGHT PER ASTM D-1557.
 3. WALKING SURFACES MUST BE LEVEL WITH PERMITTED VERTICAL CHANGES IN FILL NOT TO EXCEED 1/4" OR REVEALED CHANGES IN LEVEL NOT TO EXCEED 1/2". REFER TO DETAIL DET-B THIS SHEET. ANY CHANGE IN LEVEL GREATER THAN 1/2" MUST BE RAMPED.
 4. TURNING SPACES ALONG ACCESSIBLE ROUTES MUST BE AT LEAST 5 FEET WIDE IN ALL DIRECTIONS AND NOT EXCEED 2% (1:48) IN ANY DIRECTION.
 5. DIRECT ACCESSIBLE ROUTES WILL BE DESIGNED TO BE A MINIMUM OF 5 FEET WIDE. THE MINIMUM CLEAR WIDTH IS 3 FEET.
 6. RAMPS ALONG ACCESSIBLE ROUTES WILL HAVE A RUNNING SLOPE GREATER THAN 5% (1:20) AND LESS THAN 8.3% (1:12).
 7. THE CROSS-SLOPE OF RAMP RUNS SHALL NOT EXCEED 2% (1:48).
 8. THE MINIMUM CLEAR WIDTH OF ANY RAMP IS 36 INCHES.
 9. THE MAXIMUM RISE FOR ANY RAMP (NOT INCLUDING CURB RAMPS) SHALL NOT EXCEED 30 INCHES. LANDINGS ARE REQUIRED AT THE TOP AND BOTTOM OF EACH RAMP. LANDINGS SHALL HAVE A CROSS-SLOPE NOT EXCEEDING 2% (1:48). SHALL BE 8 FEET LONG AND AT LEAST AS WIDE AS THE RAMP CLEAR WIDTH. IF THERE IS A CHANGE OF DIRECTION AT A LANDING, THEN THE LANDING MUST BE AT LEAST 5 FEET WIDE AND 5 FEET LONG.
 10. CURB RAMPS ALONG ACCESSIBLE ROUTES SHALL NOT BE STEEPER THAN 10% (1:10).
 11. IF CURB RAMP SIDES ARE FLARED, THE FLARES SHALL NOT BE STEEPER THAN 10% (1:10).
 12. LANDINGS ARE REQUIRED AT THE TOP OF ALL CURB RAMPS. THE CLEAR LENGTH OF THE LANDING SHALL BE A MINIMUM OF 36" AND WILL BE AS WIDE AS THE CURB RAMP.
 13. CURB RAMPS SHALL BE LOCATED OR PROTECTED TO PREVENT THEIR OBSTRUCTION BY PARKED VEHICLES.
 14. HANDRAILS ARE NOT REQUIRED ON CURB RAMPS.
 15. WHERE DETECTABLE WARNING IS REQUIRED AT CURB RAMPS, THE DETECTABLE WARNING SHALL BE 24" MINIMUM IN DEPTH AND SHALL EXTEND THE FULL WIDTH OF THE RAMP. THE DETECTABLE WARNING SHALL BE LOCATED SO THE EDGE NEAREST THE CURB IS 8 INCHES MINIMUM AND 8 INCHES MAXIMUM FROM THE CURB LINE.
 16. ACCESSIBLE PARKING SPACES ON SITE SHALL BE PROVIDED AS REQUIRED IN SECTION 502 OF THE A.D.A. IF THE SITE HAS MORE THAN ONE PARKING FACILITY, EACH FACILITY IS REQUIRED TO MEET THESE REQUIREMENTS SEPARATELY. THE REQUIRED NUMBER OF SPACES SHALL BE BASED ON THE TOTAL NUMBER OF PARKING SPACES IN EACH PARKING FACILITY ON SITE.
 17. FOR EVERY SIX OR FRACTION OF SIX ACCESSIBLE PARKING SPACES, ONE VAN ACCESSIBLE SPACE SHALL BE PROVIDED.
 18. ACCESSIBLE PARKING SPACES SHALL BE LOCATED ON THE SHORTEST ACCESSIBLE ROUTE FROM PARKING TO A BUILDING ENTRANCE. IF THERE IS MORE THAN ONE ACCESSIBLE ENTRANCE, PARKING SHALL BE DISPERSED ALONG THE SHORTEST ACCESSIBLE ROUTE TO THE ACCESSIBLE ENTRANCES.
 19. BARRIER FREE CAR PARKING SPACES SHALL BE A MINIMUM OF 8 FEET WIDE WITH AN ACCESS AISLE 5 FEET WIDE MINIMUM. VAN ACCESSIBLE PARKING SPACES SHALL BE AT LEAST 11 FEET WIDE WITH A 5' WIDE ACCESS AISLE. VAN ACCESSIBLE SPACES ARE ALSO ACCEPTABLE WITH AN 8 FOOT WIDTH AND 8 FOOT WIDE ACCESS AISLE. THE ACCESS AISLE IN ALL CASES MUST EXTEND THE FULL LENGTH OF THE PARKING SPACE.
 20. SURFACE SLOPES WITHIN THE PARKING SPACES AND AISLES SHALL NOT EXCEED 2% (1:48).
 21. ACCESSIBLE AREAS INCLUDING PARKING SPACES, AISLES AND PATHWAYS, REQUIRE A MINIMUM VERTICAL CLEARANCE OF 98 INCHES.
 22. ACCESSIBLE PARKING SPACES ARE REQUIRED TO BE IDENTIFIED BY SIGNS. THE SIGNS SHALL INCLUDE THE INTERNATIONAL SYMBOL OF ACCESSIBILITY. VAN PARKING SPACES ARE REQUIRED TO BE DESIGNATED AS "VAN ACCESSIBLE". REFER TO DETAILS ON THIS SHEET.

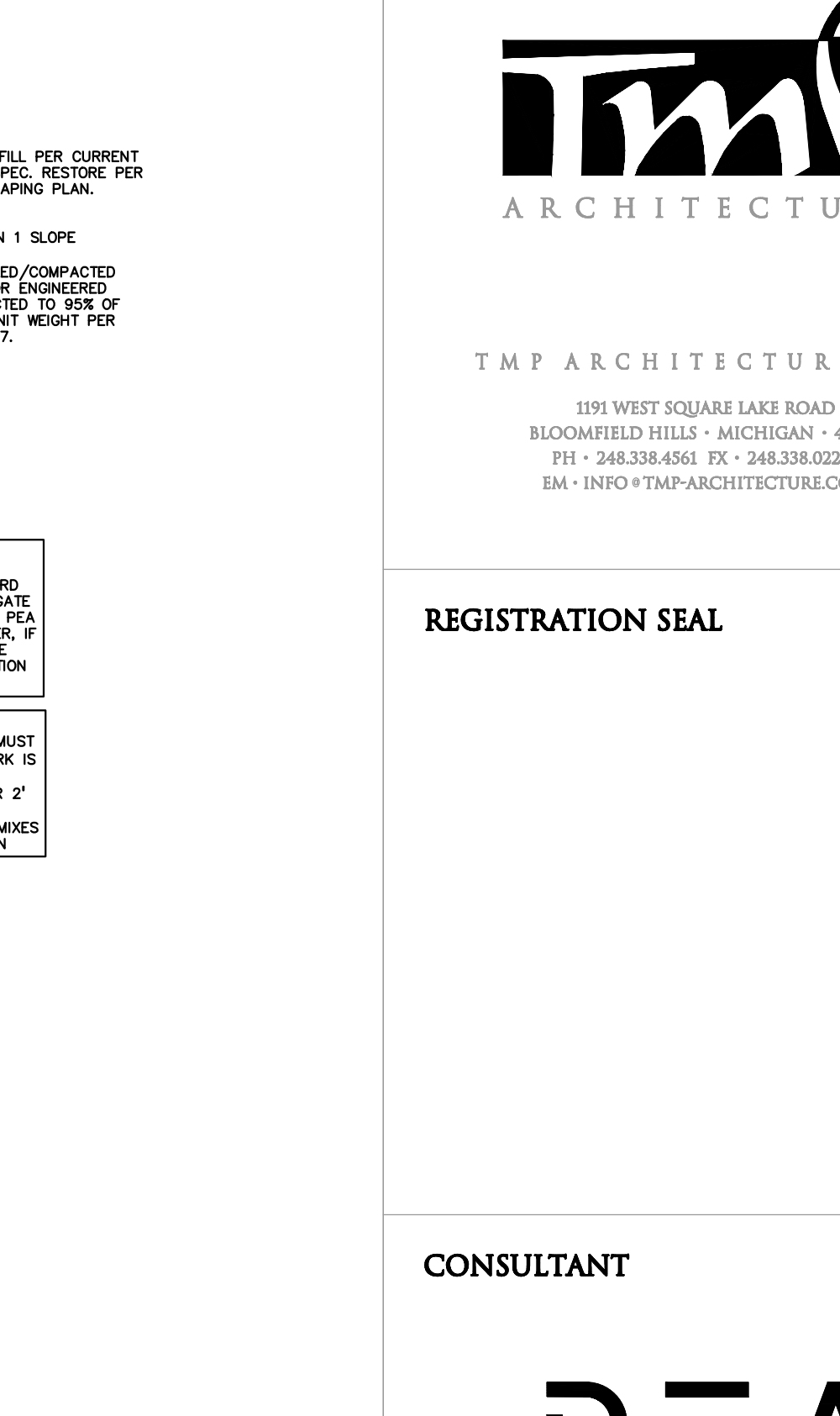
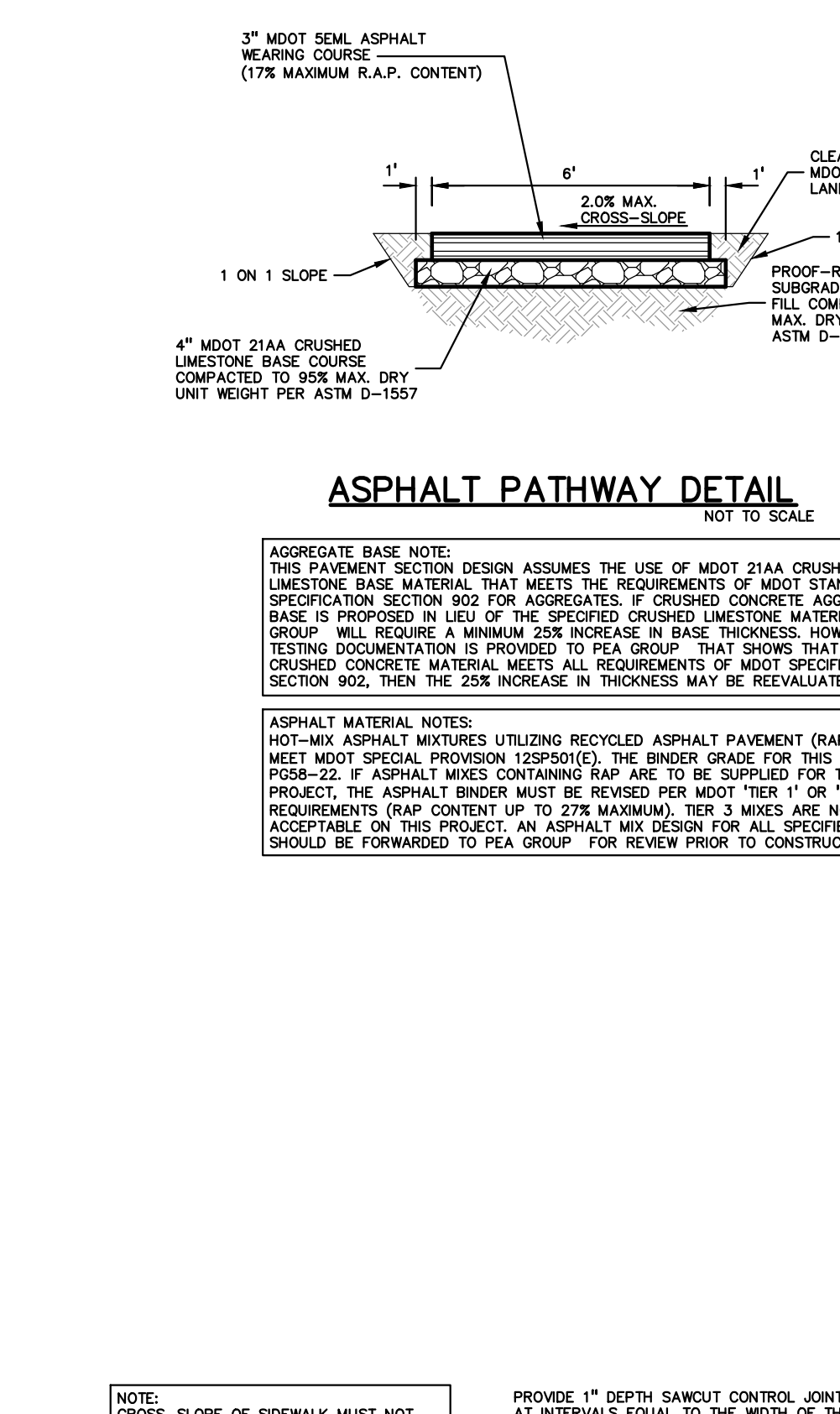
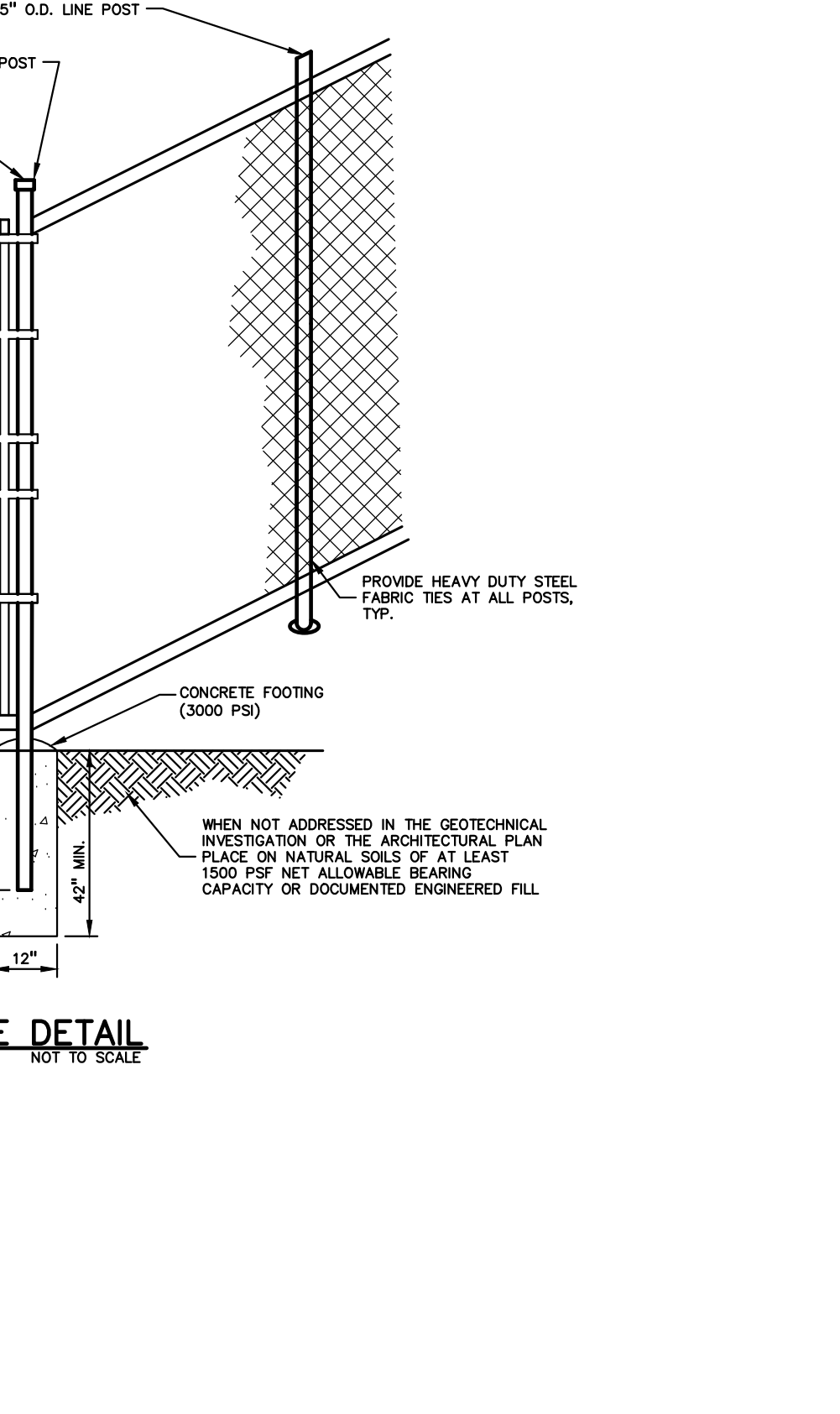

- PAVING NOTES:**
1. IN AREAS WHERE NEW PAVEMENTS ARE BEING CONSTRUCTED, THE TOPSOIL AND SOIL CONTAINING ORGANIC MATTER SHALL BE REMOVED PRIOR TO PAVEMENT CONSTRUCTION.
 2. REFER TO ARCHITECTURAL PLANS FOR DETAILS OF FROST SLAB AT EXTERIOR BUILDING DOORS.
 3. CONSTRUCTION TRAFFIC SHOULD BE MINIMIZED ON THE NEW PAVEMENT. IF CONSTRUCTION TRAFFIC IS ANTICIPATED ON THE PAVEMENT STRUCTURE, THE INITIAL LIFT THICKNESS AND PLACEMENT OF THE FINAL LIFT COULD BE DELAYED UNTIL THE MAJORITY OF THE CONSTRUCTION ACTIVITIES HAVE BEEN COMPLETED. THIS ACTION WILL ALLOW REPAIR OF LOCALIZED FAILURE, IF ANY DOES OCCUR, AS WELL AS REDUCE LOAD DAMAGE ON THE PAVEMENT SYSTEM.
 4. ALL EXPANSION JOINTS AND CONCRETE PAVEMENT JOINTS BE SEALED.
 5. CONCRETE PAVEMENT JOINTING - UNLESS SHOWN OTHERWISE IN THE PLANS OR REQUIRED BY THE AUTHORITY HAVING JURISDICTION:
 - 5.1. WHERE PROPOSED CONCRETE ABUTS A STRUCTURE, PROVIDE A MINIMUM 1/2" EXPANSION JOINT. THE JOINT FILLER BOARD MUST BE AT LEAST THE FULL DEPTH OF THE CONCRETE AND HELD DOWN A 1/2" TO ALLOW FOR SEALING.
 - 5.2. WHERE PROPOSED CONCRETE ABUTS EXISTING CONCRETE OR IN BETWEEN POURS OF PROPOSED CONCRETE (CONSTRUCTION JOINT), PROVIDE 5/8" DOWELS EVERY 30" CENTER TO CENTER HALF WAY ALONG THE THICKNESS OF THE PROPOSED PAVEMENT. ALTERNATE DOWELS SIZES AND SPACING MUST BE APPROVED BY THE ENGINEER PRIOR TO COMMENCING WORK AND VIA THE SUBMITTAL PROCESS.
 - 5.3. WHERE PROPOSED CONCRETE ABUTS EXISTING OR PROPOSED SIDEWALK OR CURBING, PROVIDE A MINIMUM 1/2" EXPANSION JOINT.
 - 5.4. CONTROL, LONGITUDINAL AND/OR TRANSVERSE JOINTS SHALL BE PLACED TO PROVIDE PANELS WITHIN THE PAVEMENT AS SQUARE AS POSSIBLE WITH THE FOLLOWING MAXIMUM SPACING PARAMETERS:
 - 5.4.1. 6-INCH THICK CONCRETE PAVEMENT: 12' X 12'
 - 5.4.2. 8-INCH THICK CONCRETE PAVEMENT: 15' X 15'
 - 5.4.3. 4-INCH THICK CONCRETE PAVEMENT: 10' X 10'
 - 5.5. IRREGULAR-SHAPED PANELS MAY REQUIRE THE USE OF REINFORCING MESH OR FIBER MESH AS DETERMINED BY THE ENGINEER. THE USE OF MESH MUST BE APPROVED BY THE ENGINEER PRIOR TO COMMENCING WORK AND VIA THE SUBMITTAL PROCESS.
 - 5.6. IF A JOINT PLAN IS NOT PROVIDED IN THE PLANS, THE CONTRACTOR SHALL SUBMIT ONE TO THE ENGINEER FOR REVIEW PRIOR TO COMMENCING WORK AND VIA THE SUBMITTAL PROCESS.
 6. CONCRETE CURBING JOINTING - UNLESS SHOWN OTHERWISE IN THE PLANS OR REQUIRED BY THE AUTHORITY HAVING JURISDICTION
 - 6.1. JOINTS WHEN ADJACENT TO ASPHALT PAVEMENT
 - 6.1.1. PLACE CONTRACTION JOINTS AT 10' INTERVALS
 - 6.1.2. PLACE 1/2" EXPANSION JOINT AT CATCH BASINS, EXISTING AND PROPOSED SIDEWALK OR EXISTING CURBING.
 - 6.1.3. PLACE 1" EXPANSION JOINT:
 - 6.1.3.1. AT SPRING POINTS OF INTERSECTIONS OR ONE OF THE END OF RADIUS LOCATIONS IN A CURVE
 - 6.1.3.2. AT 400' MAXIMUM INTERVALS ON STRAIGHT RUNS
 - 6.1.3.3. AT THE END OF RADIUS AT OPPOSITE ENDS IN A CURBED LANDSCAPE ISLAND
 - 6.2. JOINTS WHEN TIED TO CONCRETE PAVEMENT
 - 6.2.1. PLACE CONTRACTION JOINTS OPPOSITE ALL TRANSVERSE CONTRACTION JOINTS IN PAVEMENT
 - 6.2.2. PLACE 1/2" EXPANSION JOINT AT CATCH BASINS, EXISTING AND PROPOSED SIDEWALK OR EXISTING CURBING.
 - 6.2.3. PLACE 1" EXPANSION JOINT OPPOSITE ALL TRANSVERSE EXPANSION JOINTS IN PAVEMENT
 - 6.2.4. CURB AND GUTTER AND CONCRETE SHALL BE TIED TOGETHER SIMILAR TO A LONGITUDINAL LANE. THE JOINT (MDOBT BY JOINT)
 - 6.3. IN BETWEEN POURS OF PROPOSED CONCRETE CURBING (CONSTRUCTION JOINT):
 - 6.3.1. CARRY THE REBAR CONTINUOUSLY BETWEEN POURS.
 - 6.3.2. IF THE REBAR IS NOT LONG ENOUGH TO CARRY CONTINUOUSLY, THEN TIE TWO PIECES OF REBAR PER THE LATEST MDOT SPECIFICATIONS.
 7. CONCRETE SIDEWALK JOINTING - UNLESS SHOWN OTHERWISE IN THE PLANS OR REQUIRED BY THE AUTHORITY HAVING JURISDICTION
 - 7.1. PLACE TRANSVERSE CONTRACTION JOINTS EQUAL TO THE WIDTH OF THE WALK WHEN WIDTH IS LESS THAN 8'
 - 7.2. PLACE TRANSVERSE AND LONGITUDINAL CONTRACTION JOINTS EQUAL TO 1/2 THE WIDTH OF THE WALK WHEN WIDTH IS EQUAL TO OR GREATER THAN 8'
 - 7.3. PLACE 1" EXPANSION JOINT WHERE ABUTTING SIDEWALK RAMP AND/OR RADIUS IN INTERSECTION
 - 7.4. PLACE TRANSVERSE 1/2" EXPANSION JOINT AT MAXIMUM OF 100' SPACING
 - 7.5. PLACE 1/2" EXPANSION JOINT WHEN ABUTTING A FIXED STRUCTURE. OTHER PAVEMENT (CONCRETE PAVEMENT AND DRIVE APPROACHES), UTILITY STRUCTURES, LIGHT POLE BASES AND COLUMNS.
 - 7.6. WHEN ALONG A CURVE, JOINTS MUST BE PERPENDICULAR TO THE CURVE WITH A MINIMUM LENGTH OF 1 FOOT BEFORE INTERSECTING ANOTHER JOINT(S) IN ANY DIRECTION. NO JOINTS ARE ALLOWED TO BE CUT AT AN ANGLE OTHER THAN 90° AT THE CURBLINE.

- CONSTRUCTION MATERIAL SUBMITTALS**
- UNLESS REQUIRED OTHERWISE IN THE PROJECT SPECIFICATIONS, THE CONTRACTOR SHALL ONLY SUBMIT THE FOLLOWING CONSTRUCTION MATERIAL SUBMITTALS, AS APPLICABLE TO THE PLANS, FOR REVIEW BY THE ENGINEER. UNLESS APPROVED IN ADVANCE AND IN WRITING BY THE ENGINEER, ANY MATERIAL SUBMITTALS PROVIDED TO THE ENGINEER FOR REVIEW IN ADDITION TO THIS LIST SHALL BE RETURNED TO THE CONTRACTOR WITHOUT A REVIEW BEING PERFORMED.
1. SOIL EROSION AND SEDIMENTATION CONTROL MEASURES
 2. UTILITY TRENCH BACKFILL MATERIAL WITH ALL MATERIAL DATA INCLUDED IN THE SUBMITTAL BEING DATED WITHIN 60 DAYS OF THE SUBMITTAL UNLESS APPROVED OTHERWISE BY THE ENGINEER
 3. STORM SEWER STRUCTURES
 4. STORM SEWER STRUCTURE FRAME AND COVERS INCLUDING CLEAN OUTS
 5. PAVEMENT AGGREGATE BASE MATERIAL WITH ALL MATERIAL DATA INCLUDED IN THE SUBMITTAL BEING DATED WITHIN 60 DAYS OF THE SUBMITTAL UNLESS APPROVED OTHERWISE BY THE ENGINEER
 6. PAVEMENT UNDERDRAIN MATERIAL AND BACKFILL WITH ALL BACKFILL MATERIAL DATA INCLUDED IN THE SUBMITTAL BEING DATED WITHIN 60 DAYS OF THE SUBMITTAL UNLESS APPROVED OTHERWISE BY THE ENGINEER
 7. PAVEMENT MIX DESIGNS SUBMITTED FOR REVIEW BY THE ENGINEER MUST FOLLOW THE CURRENT MDOT REVIEW CHECKLISTS AS SUMMARIZED BELOW AND ALL MATERIAL DATA INCLUDED IN THE SUBMITTAL BEING DATED WITHIN 60 DAYS OF THE SUBMITTAL UNLESS APPROVED OTHERWISE BY THE ENGINEER.
 - B.1. CONCRETE MIX DESIGN REVIEW CHECKLIST (FORM 2000)
 - B.2. SUPERPAVE MIX DESIGN CHECKLIST (FORM 1849)
 - B.3. MARSHALL MIX DESIGN CHECKLIST (FORM 1849)
 8. SITE FENCING AND GATES
 9. ANY ITEMS SHOWN IN THE PLANS OR DETAIL SHEETS THAT SPECIFICALLY STATE FOR THE CONTRACTOR TO SUBMIT A SHOP DRAWING TO THE ENGINEER FOR REVIEW. THESE ITEMS INCLUDE, BUT ARE NOT LIMITED TO:
 - ANY SPECIALTY ITEMS SHOWN IN THE PLANS OR DETAIL SHEETS THAT SPECIFICALLY DO NOT STATE FOR THE CONTRACTOR SHALL SUBMIT A SHOP DRAWING TO THE ENGINEER FOR REVIEW BUT THE CONTRACTOR REQUESTS TO BE REVIEWED. THE CONTRACTOR'S REQUEST FOR REVIEW MUST BE IN WRITING AND APPROVED BY THE ENGINEER PRIOR TO SUBMITTING THE INFORMATION.

- ASPHALT PATHWAY DETAIL**
- CHAIN LINK FENCE DETAIL**
- ASPHALT PLAYSCAPE DETAIL**
- CONCRETE SIDEWALK**
- INFILTRATION BASIN DETAIL**

SOIL EROSION & SEDIMENTATION CONTROL NOTES

- The following items are intended to be a guide to the contractor in evaluating Soil Erosion control requirements for the project. Specific Soil Erosion control devices and locations may be detailed on the plans. The contractor should also note that Soil Erosion and Sedimentation controls are included in the project unless specified otherwise on the plans or in the specifications.
- All erosion and Sediment control work shall conform to the permit requirements and the standards and specifications of the City of Troy.
- Daily inspections shall be made by the contractor for effectiveness of Soil Erosion and Sedimentation control measures and any necessary repairs shall be performed without delay.
- Erosion and any sedimentation from work on this site shall be contained on the site and not allowed to collect on any off-site areas or in waterways.
- Waterways include natural or man-made open ditches, streams, storm drains, lakes and ponds.
- Contractor shall apply temporary soil erosion and sedimentation control measures when required or as directed. Contractor shall remove temporary measures as soon as permanent stabilization of slopes, ditches, and other earth changes has been accomplished.
- Staging the work will be done by the contractor as indicated on the Soil Erosion plans and as required to ensure progressive stabilization of disturbed earth.
- The contractor will establish soil erosion control measures in the early stages of construction. Sediment control measures will be applied as a perimeter defense against any transporting of silt off the site.
- Engineer and owner certification must be included on the plans.
- Separate sheets showing soil erosion and sedimentation control plans must be provided.
- The following guidelines are to be implemented:
 - Check Dams:
 - Stone size must be increased with increased slope and velocity.
 - Side slope of the dam should be 2:1 or flatter.
 - Straw bales are not to be used for check dams.
 - Add stones as needed to maintain design height and cross section.
 - Any accumulation of sediment shall be removed and stockpiled in a stabilized area to prevent the material from eroding back into the drainage course.
 - Vegetative Buffer Zones:
 - Vegetation must be maintained in a vigorous condition.
 - Reshape and reseed areas where concentrated flow occurs or vegetation fails.
 - To be used for sheet flows only.
 - Not to be used as a roadway.
 - Silt Fence:
 - Must be installed along the contour line.
 - Is not to be used in areas of concentrated flow.
 - Must be trenched in at least 6 inches and backfilled.
 - Multiple rows are to be used up a slope.
 - Accumulated sediment must be periodically removed.
 - Where necessary, a support fence shall be used to support the geotextile filter fabric.
 - To be removed after site is permanently stabilized.
 - Inlet Sediment Trap:
 - The sediment deposition area and nonwoven geotextile filter fabric should be cleaned of all accumulated sediment after each storm.
 - After all contributing areas are stabilized, the filter fabric will be removed, sediment deposition area filled, and a sod inlet filter placed over the disrupted lawn area.
 - The filter material used to backfill parking lot drainage holes will be pea stone. The side excavation for the placement of this material will not be deeper than the invert of the drainage holes.
 - Inlet Filters After Paving or Grading:
 - Inlet filters will remain in place until all denuded areas contributing to them are stabilized with vegetation.
 - Periodic inspection and maintenance will be provided to insure that filters are functioning properly.
 - Sod Inlet Filter:
 - Sod inlet filters will only be used to handle light concentrations of sediment. Recommended for use after final grading is complete and during the establishment of a vegetative cover.
 - Catch basin inlet covers may be wrapped in a non-woven geotextile filter fabric for additional filtration.
 - Periodic inspection and maintenance must be provided to insure efficient operation.

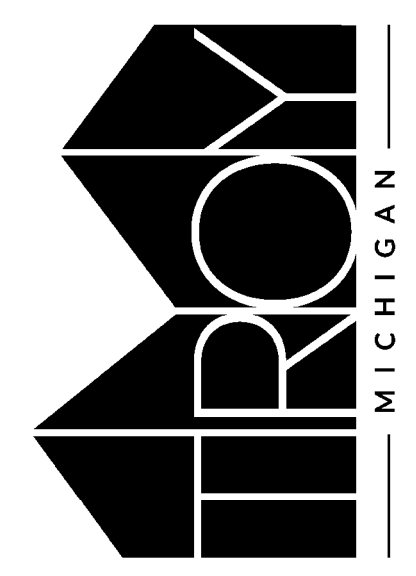

STANDARD SOIL EROSION CONTROL DETAILS
ENGINEERING DEPARTMENT

APPROVED BY: WILLIAM J. HUOTARI, CITY ENGINEER DATE: JUNE 2019

DATE	GENERAL UPDATES	REMARKS
APRIL 2019		

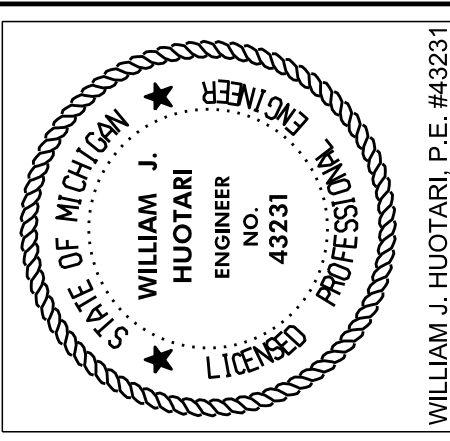

3 FULL WORKING DAYS BEFORE YOU DIG CALL 811

Contractor Note: The locations of existing underground utilities are shown on the plans. The contractor shall determine the exact location of all existing utilities before commencing work. The contractor agrees to be responsible for any and all damages which may be caused by their failure to exactly locate and preserve their own and all underground utilities.

1-800-485-2171 www.michigan.gov

CONTRACT NO. XX-XX
PROJECT NO. XX-XXX.X

- Project Information
- a. Type of soil being disrupted:
- Derived from: Soil Survey Soil Borings Other
- b. Present the chronological sequence and expected time of year for each major phase of earth disruption.
- Site Clearing DATE
- Soil Erosion Control
- Mass Balancing
- Underground Utilities
- Paving
- Restoration / Stabilization
- c. Indicate the measures proposed to prevent sediment from leaving the site:

- Hydrologic Characteristics of Site
- a. Type of "Offsite" drainage outlet(s) available for this site:
- County Drain Name of Drain:
Lake/Pond Name of Lake/Pond:
River/Stream Name of River/Stream:
Enclosed Drain Name of Enclosed Drain:
Detention Basin (with outlet)
Wetland Retention Basin (no outlet)
Overland Flow Open Ditch
- b. Distance to nearest lake, stream, pond, open drain, or wetland:
- c. Does the project include any work or disruption with a flood plain (Yes or No)?
- d. Does the project include work within the cross-section of a lake/stream (Yes or No)?
- e. Is a MDEQ Permit required (Yes or No)? If Yes, what is the MDEQ Permit Number (if known):
- f. If MDEQ Permit is required and application has not been submitted, what is the expected date of submittal?

Builders and developers working in Troy are responsible for complying with the regulations for temporary Storm Drain inserts, also known as "siltbags". The inserts are used on many construction projects to catch sediment not captured upstream by other construction-related erosion control devices and can be an important temporary environmental safeguard.

Builders must clean and/or replace the inserts when half of the trap is filled with sediment.

Builders must inspect and maintain the inserts whenever 1/2 inch of rain falls within a 24-hour period.

The inserts are to be removed by the builders within 30 days of site stabilization or after the temporary erosion measures are no longer needed.

If inserts are removed during times of flooding, the builder is responsible for re-installing them per regulations.

Silt sock inserts are required for all developments with curb inlets or pavement inlets. Rear yard catch basins may utilize a non-woven Geotextile fabric.

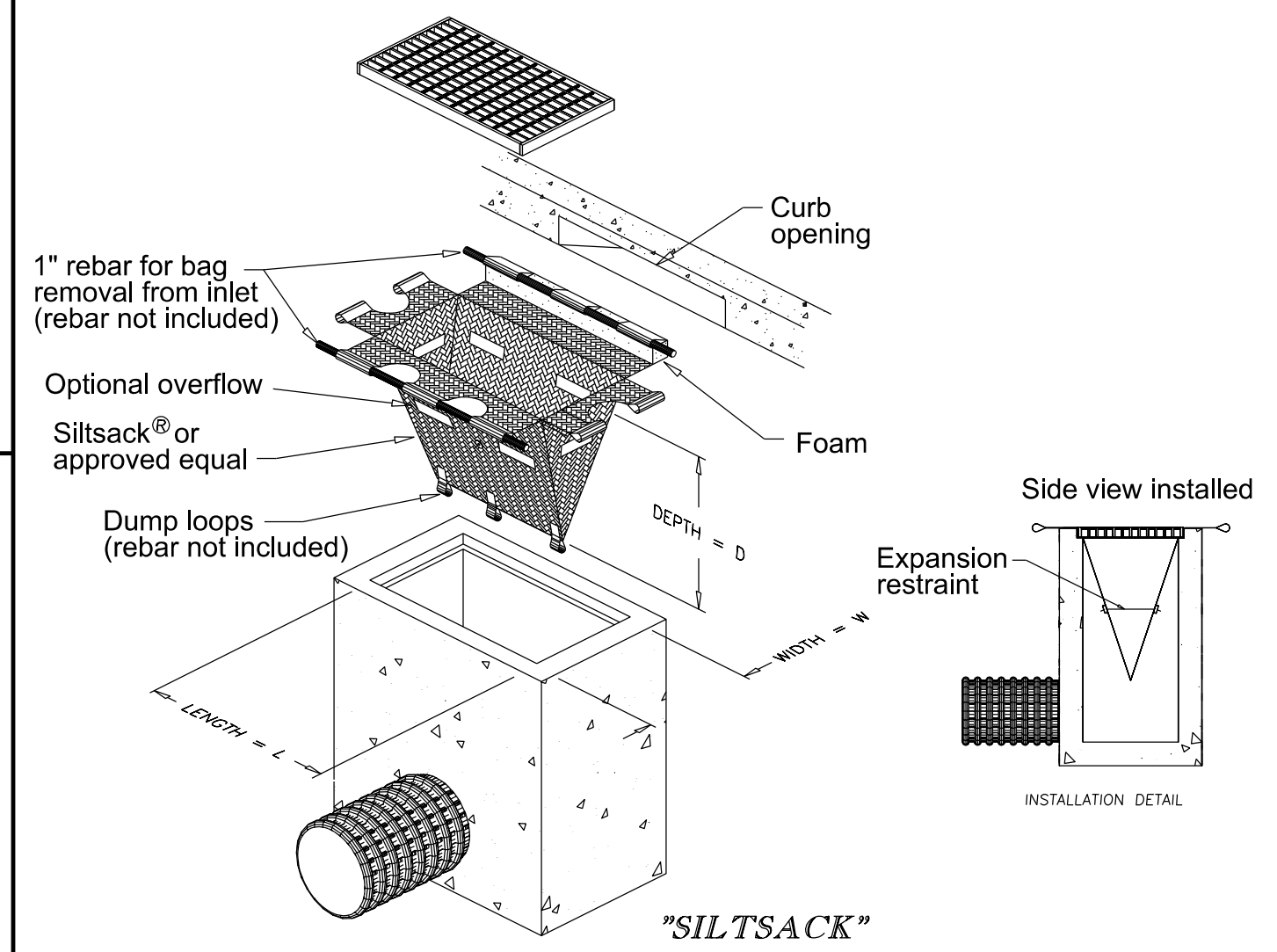

The graph listed below is used to determine the adequacy of an existing vegetative buffer zone for use as a sediment filter. This graph is only applicable if the vegetation is a dense well-grown stand of ground cover, at least 4" in height. An area covered with bushes and trees without a good ground cover is not acceptable.

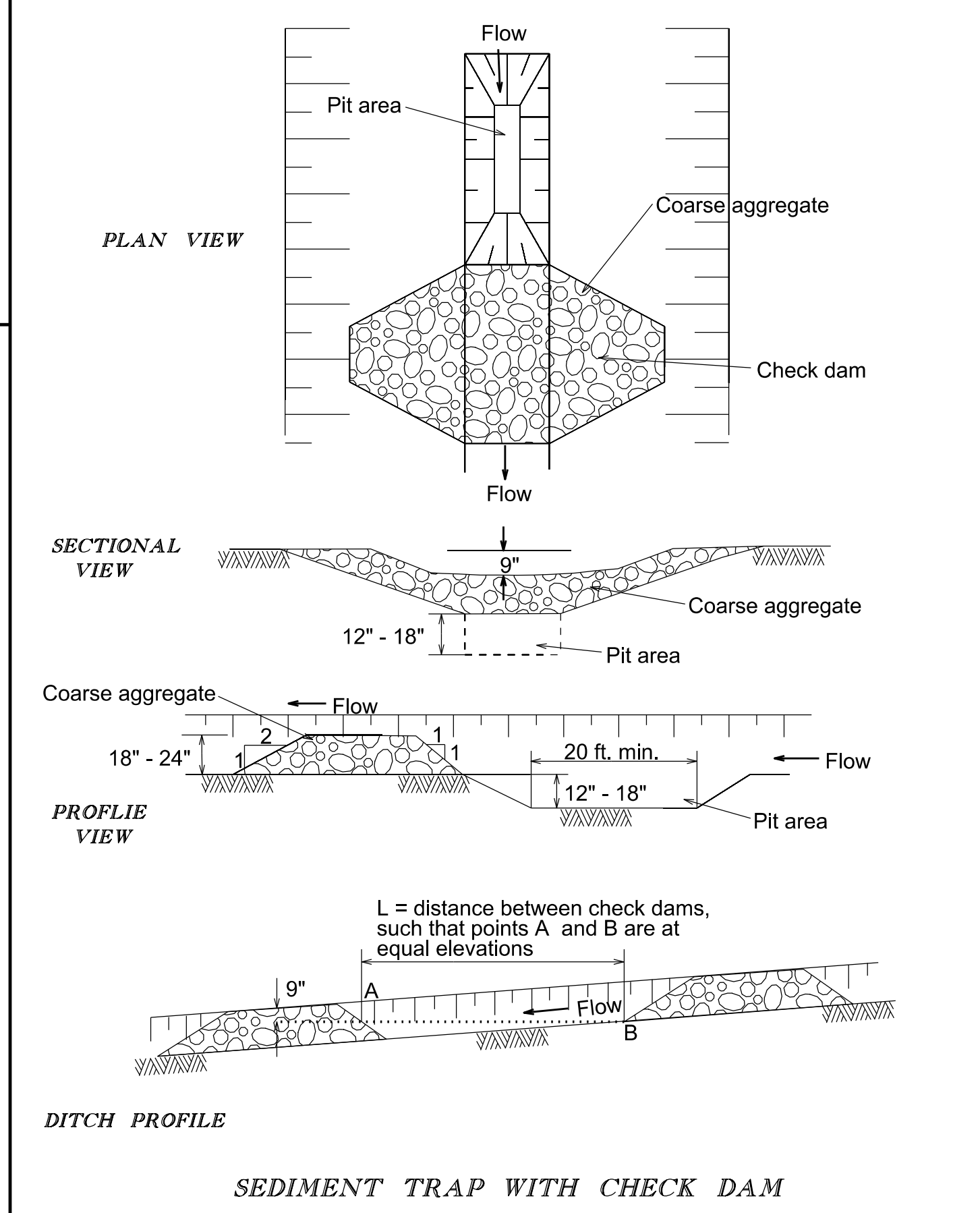
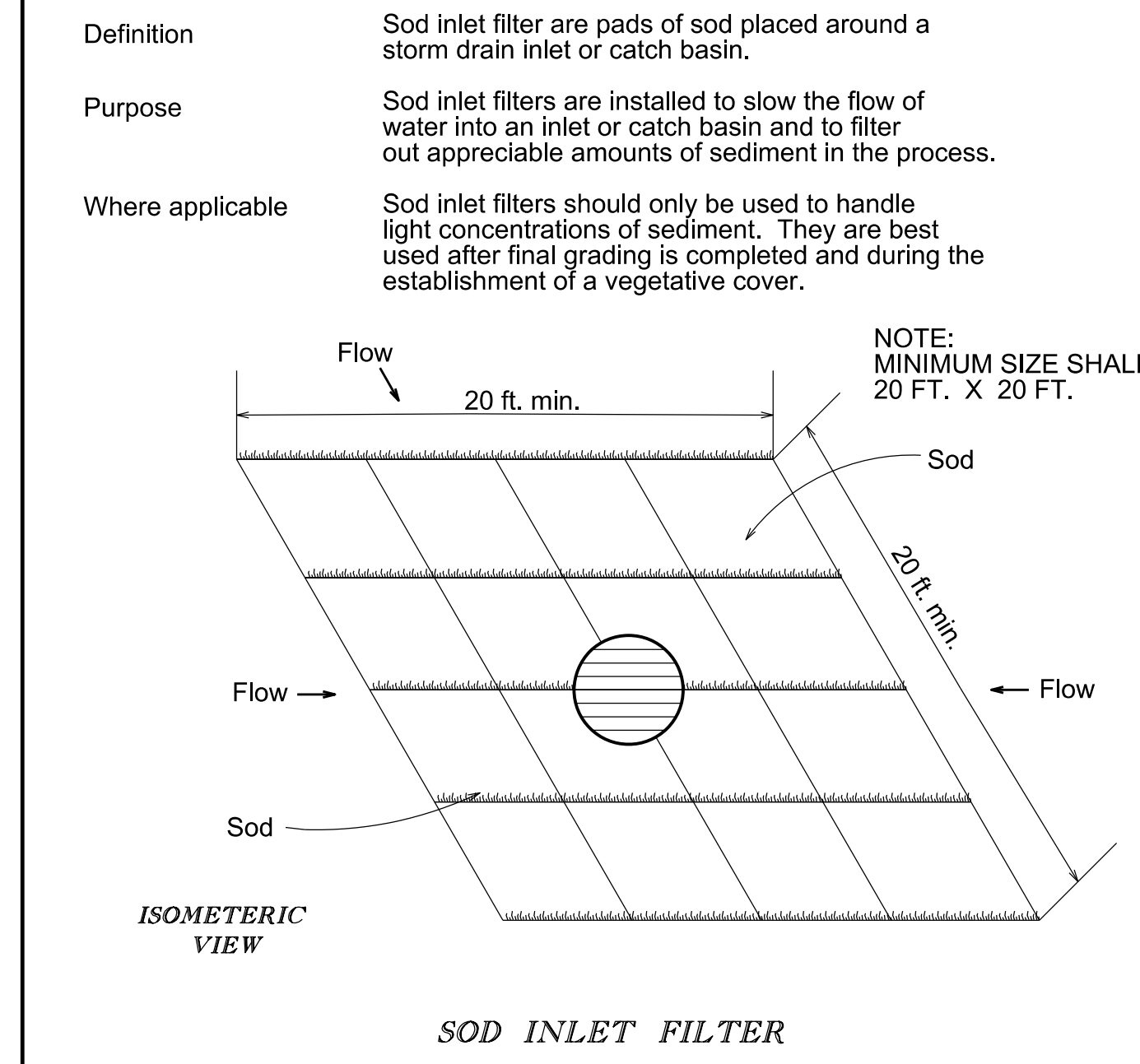
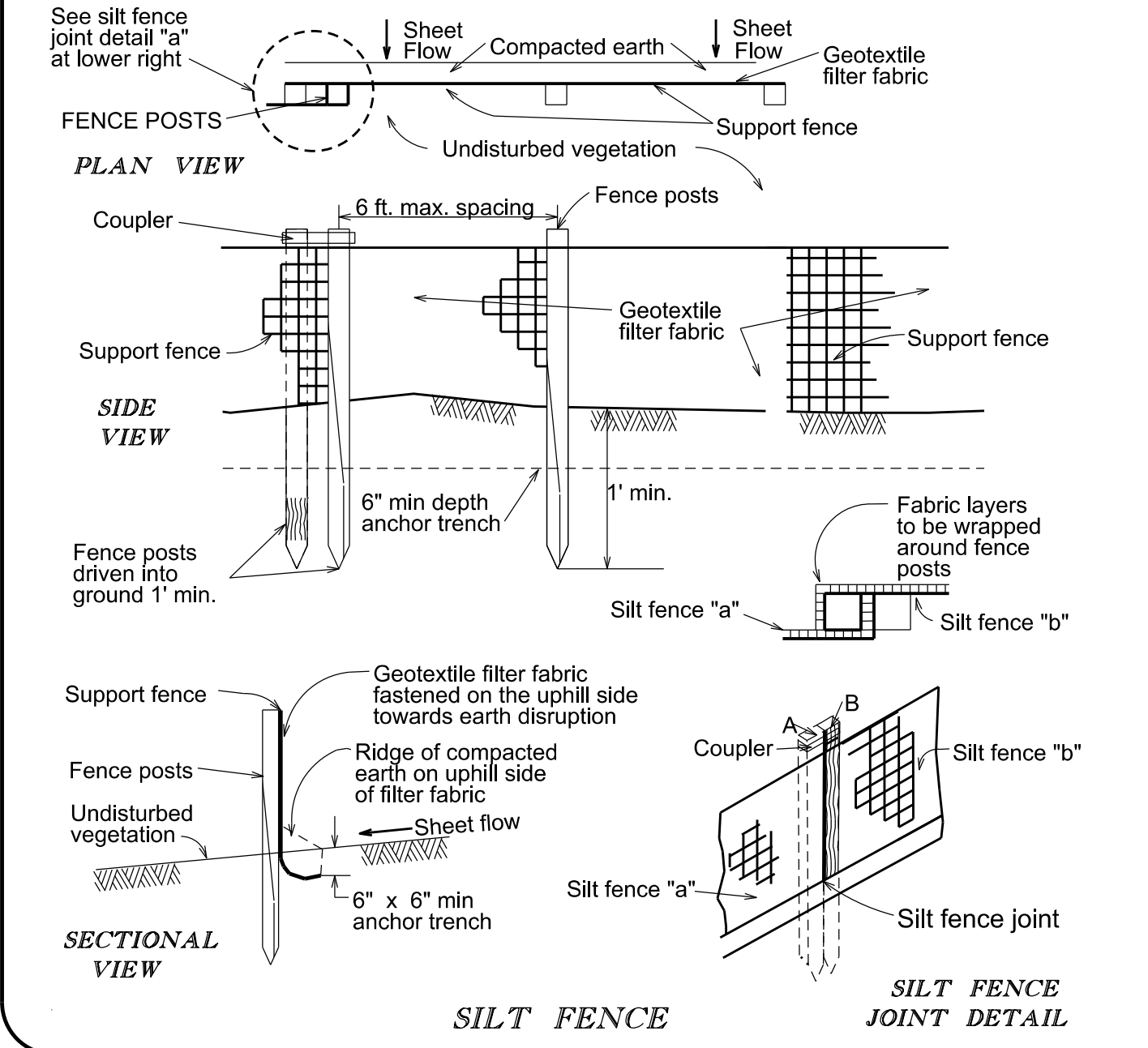
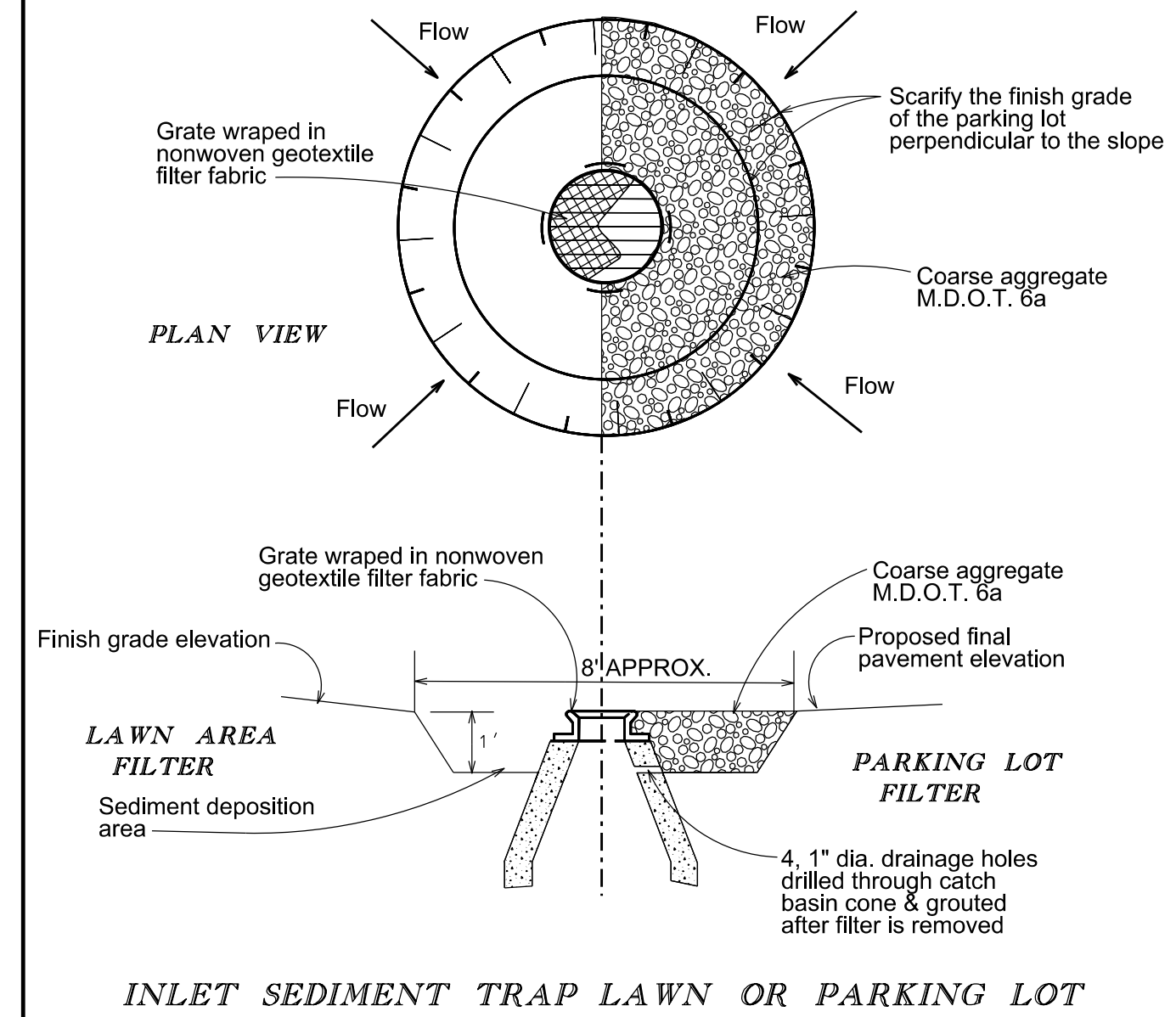
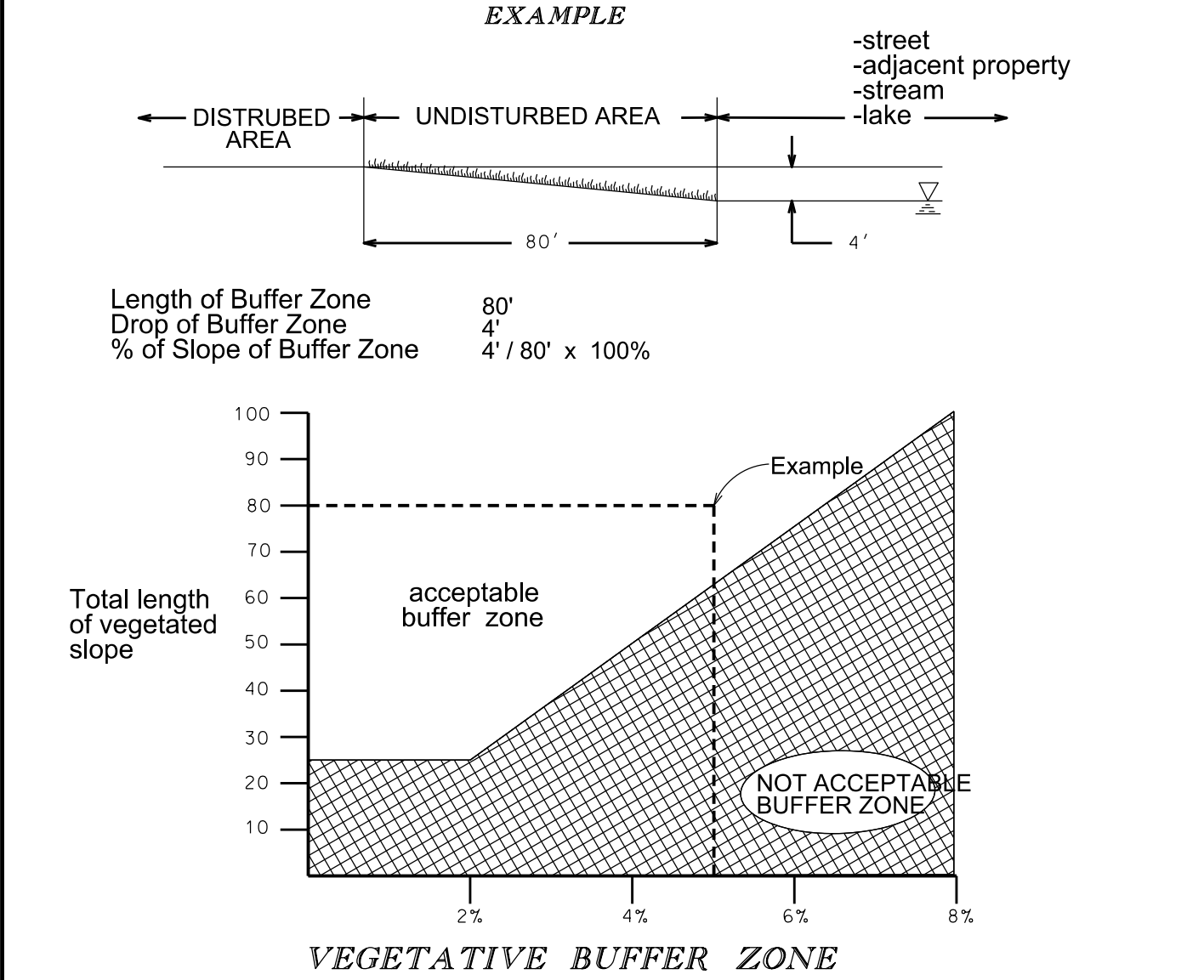

GENERAL NOTES

- All construction shall conform to the current standards and specifications of the City of Troy. Prior to construction, the contractor shall attend a reconstruction meeting at a time and place arranged by the City Engineer, in which various utility companies and governmental agency representatives will be present. The design engineer shall submit approved plans to all utility companies and governmental agencies 10 (ten) days prior to the reconstruction meeting. Construction shall start within 3 (three) weeks of meeting. The contractor shall notify the City Engineer 72 hours prior to starting any work.
- The entire project area of publicly funded projects, and all areas not under the ownership of any private developer for privately funded projects, shall be digitally recorded in color prior to the start of construction. The DVD shall be utilized by the City to determine construction related damage and to assure adequate restoration.
- Before start of construction, the contractor must request and have in their possession a copy of a valid permit to construct a connection to, or an extension of, the Storm Water Drainage System.
- Prior to any excavation, the contractor shall call Miss Dig (1-800-482-7171) for the location of underground facilities and shall also notify representatives of other utilities located in the vicinity of the work. The contractor shall assume responsibility for the protection of all existing utilities, services and mains during construction. All costs for locating, removing and replacing or relocating these utilities, services and mains shall be included in the cost of constructing the sanitary sewer. All utilities, services and mains damaged during construction shall be repaired with like material. The contractor shall verify the depth and horizontal location of all existing utilities, services and mains before any work is started. The exact location of existing utilities, services and mains shall be determined by hand digging.
- A City of Troy, Water Resources Commissioner's, Road Commission for Oakland County, and/or Michigan Department of Transportation permit is required for all construction within their Right-of-Ways. WRC must witness the new connection, contact the WRC office at 248-865-1105 - 48 hours prior to starting work. It is the contractor's responsibility to secure all permits and bonds prior to construction, or to insure that all required permits and bonds have been obtained prior to starting construction.
- The contractor shall abide by all the requirements of the Right-of-Way owner regarding construction of storm sewer mains, maintaining traffic, barricading, boring, backfill and restoration. There will be no additional compensation due the contractor for complying with these requirements.
- The contractor shall implement all soil erosion control measures indicated in the permit and/or shown on the plans prior to making any earth changes.
- Prior to the start of construction, the contractor shall furnish material certificates to the City verifying that all the materials used on the project are in accordance with the specifications.
- All construction changes must have written approval of the Project Engineer.
- Sewer Pipe Material:
 - Reinforced concrete circular sewer pipe conforming to the current ASTM specification C-76 (Wall C) with size and class as indicated on the plans; minimum class III. All reinforced concrete sewer pipe shall be cast with reinforcing steel extending into the spigots. All joints and gaskets shall be modified tongue and groove, conforming to the requirements of ASTM (C-443). All sewer pipe 30" and larger shall have pointed joints.
 - Plastic circular sewer pipe conforming to the current ASTM specifications for PVC Corrugated with smooth interior wall (A-2000) or high-performance polypropylene (N-12 HP) when approved for use by the City Engineer. All joints and gaskets shall conform to the respective ASTM specifications.
 - The following storm sewer pipe materials may be used only with approval of the City Engineer. If soils PH & Resistivity tests demonstrate a PH of 5.0 to 9.0 and an Electrical Resistance of 2000 OHM/CM/CU or higher, then helically corrugated, full welded seam, AASHTO M-218 steel pipe, gauge as shown, manufactured according to AASHTO M-36 with 2 2/3" x 1/2", aluminumized at 1.00 oz per sq. ft. per AASHTO M-274 may be used. Corrugated steel pipe shall have two circumferential corrugations rolled on each end of each section. Steel coupling bands of the same material as the pipe, fitting the pipe configuration with two "O" Ring rubber gaskets shall produce a watertight joint ("Hugger Bands").
 - Underdrains, rear yard and ditches, slotted perforations of 1.90 - 2.00 square inches per foot of pipe length. A-2000, N-12 or approved equal.
 - All sump and building service connections shall be 3" Polyvinyl Chloride (PVC) sewer pipe, schedule 40 with chemically fused joints and connect to a catch basin or manhole. No blind taps. The joint between two dissimilar sizes or types of building lead pipe shall be made with a proper fitting acceptable to the City Engineer.
- All new manholes shall have approved flexible, water-tight seals where pipes pass through walls. Manholes shall be precast reinforced concrete in accordance with ASTM C478 current specifications. Precast manhole joints and gaskets shall be modified tongue and groove in accordance with ASTM C443 current specifications. Precast manhole cone sections shall be City of Troy modified eccentric cone type.
- All precast manholes, slab bases, concrete pipe and concrete channelization shall be manufactured with Type II, IP or IIA cement.
- Manhole steps shall normally be provided on a back wall of the manhole furthest from traffic, manhole steps shall be factory installed at 16 inches center to center spacing. Steps shall be M.A. Industries P.S.I. Polypropylene MSU #360 ALU Poly (or approved equal).
- Existing manholes shall be tapped by coring for sewers 6" thru 15" in diameter. Manhole taps for 18" diameter sewers and larger shall have holes drilled at 4 inches center to center around the periphery of the opening to create a plane of weakness before breaking out the section. Non-shrink grout shall be used to seal the opening and a concrete collar shall be poured 12 inches around the pipe and extend 12 inches beyond the opening. If the wall of the structure being tapped is damaged, the City shall decide if it can be repaired and approve the method. If the structure cannot be repaired it will be replaced.
- A mainline trace wire must be installed, with all service lateral trace wires properly connected to the mainline trace wire, to ensure full tracing/locating capabilities from a single connection point. Lay mainline trace wire continuously, by-passing around the outside of manholes/structures on the North or East side. Trace wire on all storm sewer laterals must terminate at an approved trace wire access box color coded green and located directly above the service lateral at the edge of road right of way.
- Unless otherwise noted on the plans, structure frame and covers shall be as follows:
 - Manhole - EJ 1000 with type "C" perforated cover with CITY OF TROY STORM on cover.
 - Catch Basin in pavement - EJ 5080 with sinusoidal m2 grate, or equal, in residential areas.
 - Catch Basin in pavement - EJ 5105 with sinusoidal m2 grate, or equal, in non-residential areas.
 - Catch Basin not in pavement - EJ 1000 with type M, N, or O1 heavy duty grate, or equal.
 - Catch Basin in Landscape area or Roadside Ditch may require the use of the following:
 - EJ 1040 type "N" oval grate or type O2 beehive grate
 - EJ 1130 type "N" oval grate or type O1 beehive grate
 - EJ 2800 type "N" oval grate or type O2 beehive grate
 - EJ 6508 or EJ 6517
- The contractor shall provide a 3 year maintenance and guarantee bond to the City, dated from the time of final acceptance by the City. The bond amount shall be 35% of constructions costs.
- Before final acceptance, As-Built drawings must be submitted to the City of Troy Engineering Department. One electronic copy (PDF) and one digital copy (DWG or DGN) is required. .

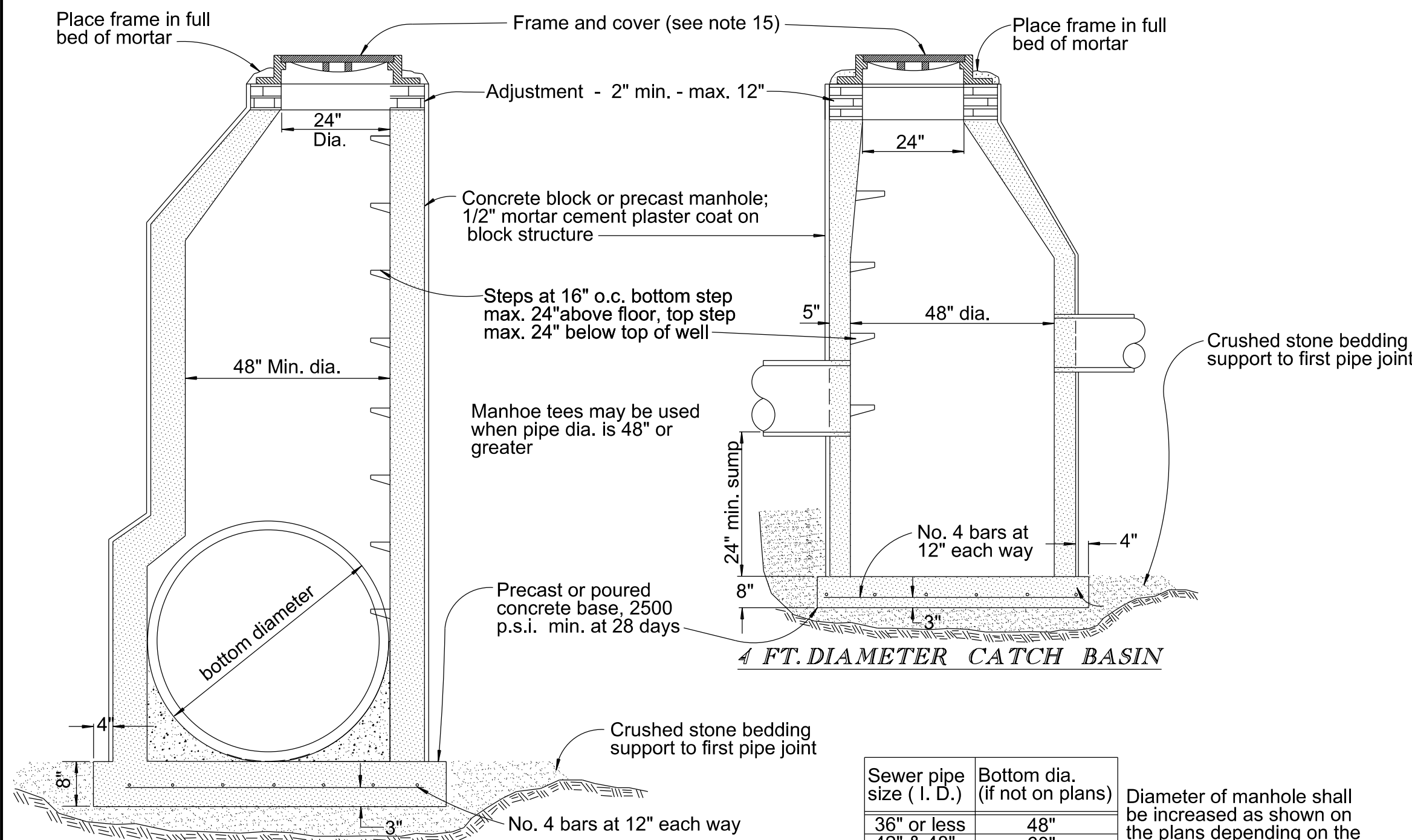

STORM SEWER MANHOLE

GENERAL PIPE BEDDING & TRENCH NOTES

- The contractor shall install the pipe in accordance with the bedding detail required for the pipe depth (measured from the top of the pipe), and trench width (measured across the trench at the top of the pipe) constructed. Alternate material and methods must be approved in writing by the City Engineer
 - Crushed stone bedding shall be utilized for dewatered ground trench's, trenches greater than 30" in width or 20' in depth.
 - Bedding material shall be as follows:
Standard bedding - MDOT 6A, 17A or 34R
Crushed stone bedding - MDOT 25A or 34G
MDOT Class II or IIA granular material
 - Backfill material shall be as follows:
Excavated material - T.D. - A
MDOT Class II granular material - T.D. - B
- Bedding shall be defined as that material placed from four (4) inches below the pipe to a point twelve (12) inches above the pipe.

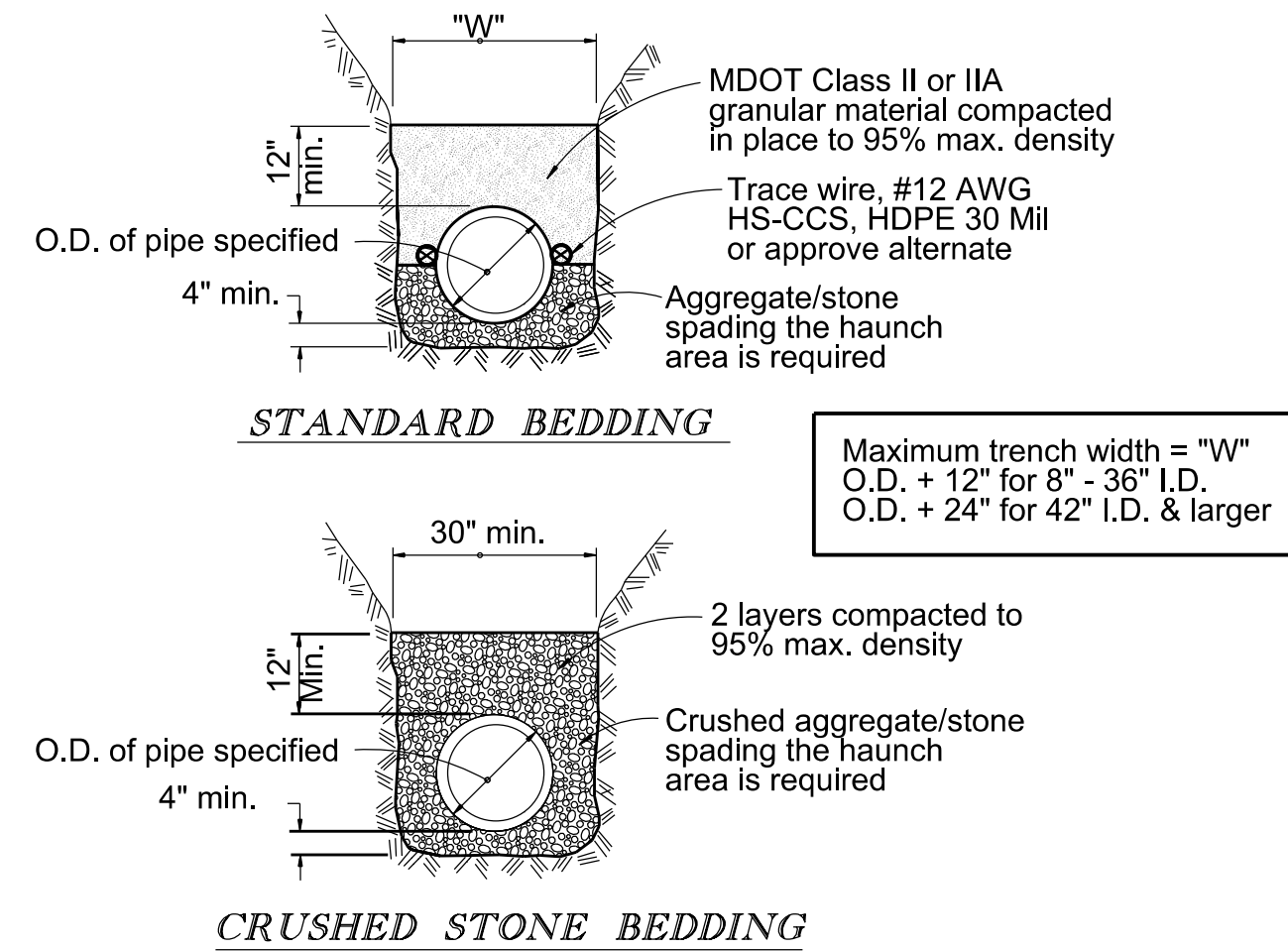

NOTE: Crushed concrete will not be allowed as bedding or backfill with underdrains or rear yard storm sewer

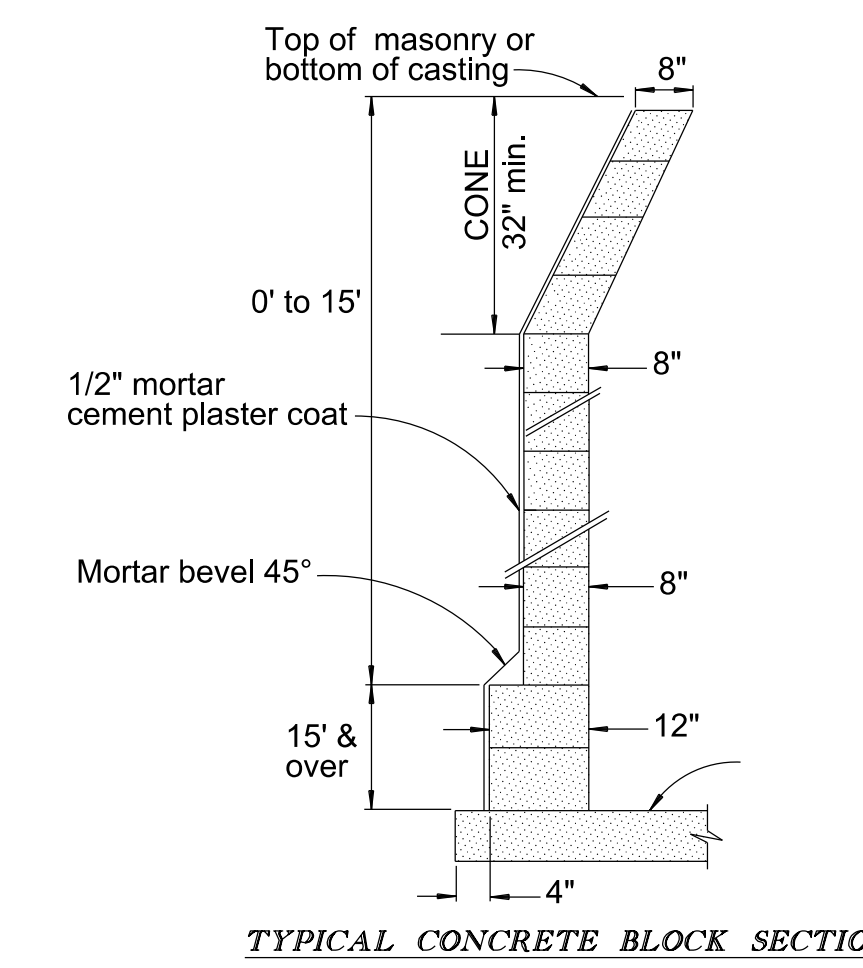
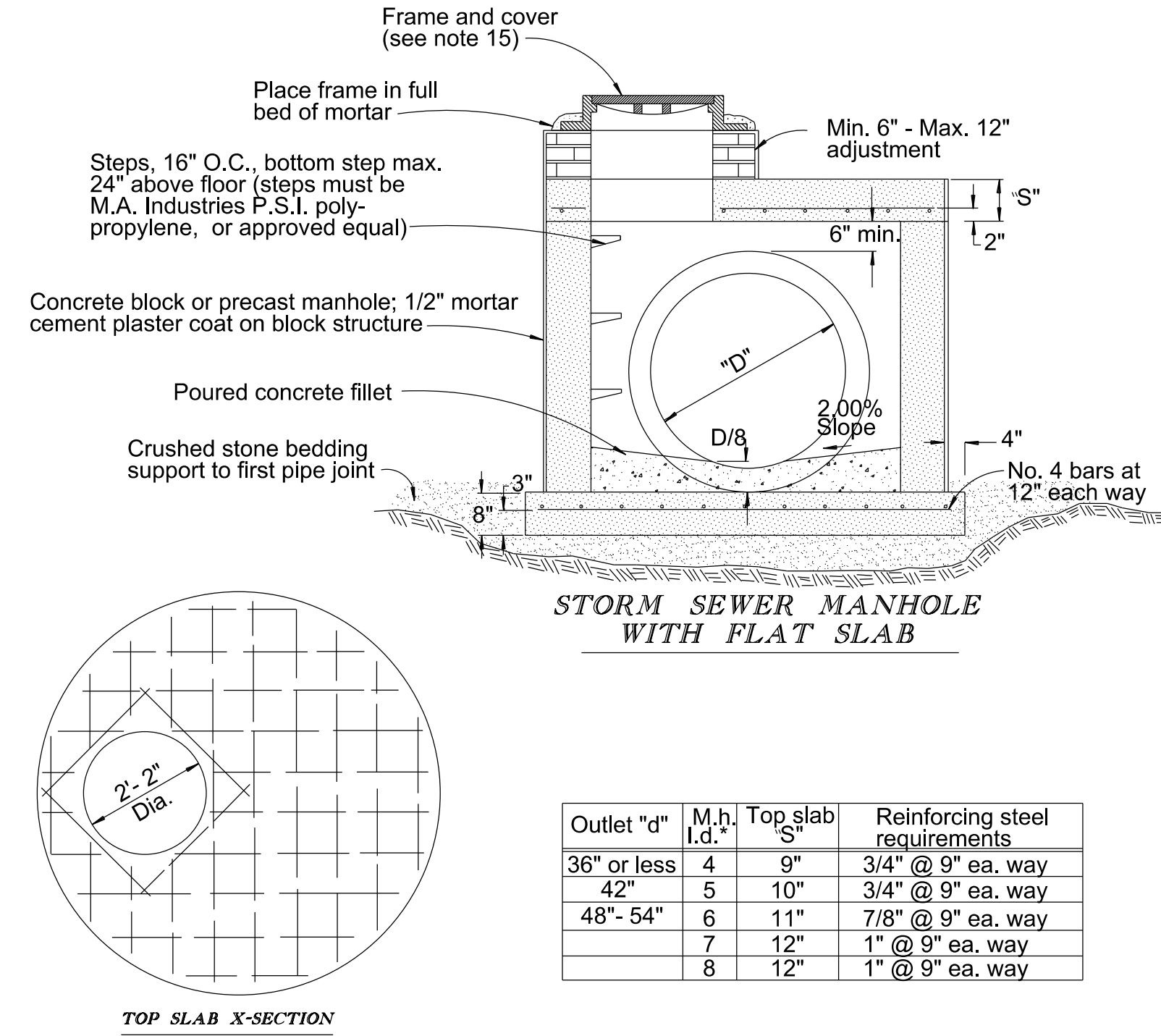

NOTE: Unless otherwise authorized by the City Engineer, each structure shall be constructed totally of either precast segments or built - up with mortar and block

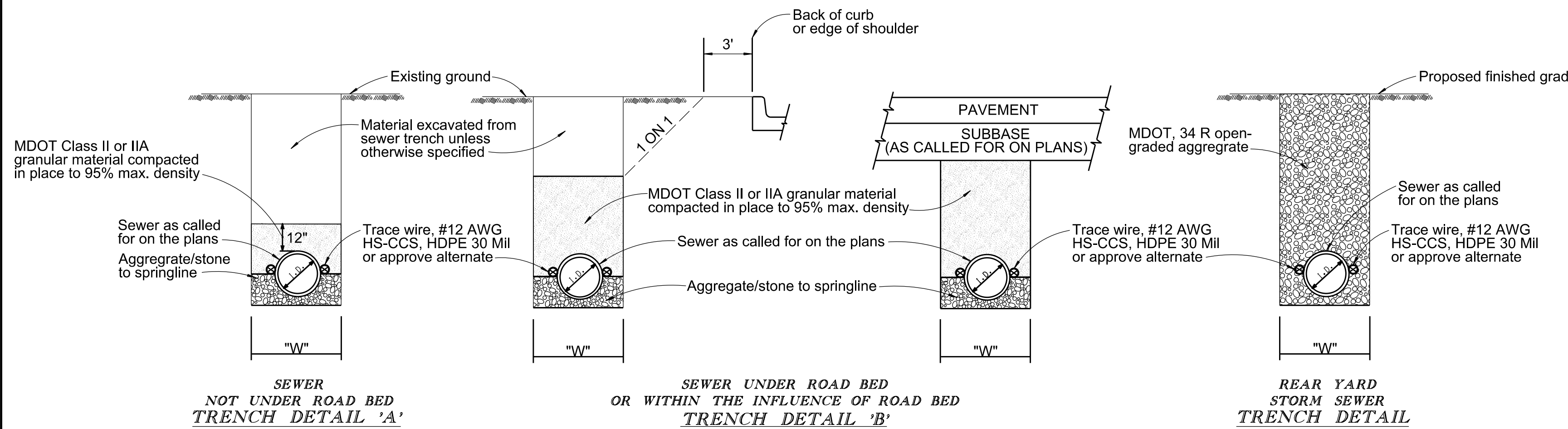

Steel Grates for End Sections See current MDOT detail Required for 12" dia. and greater

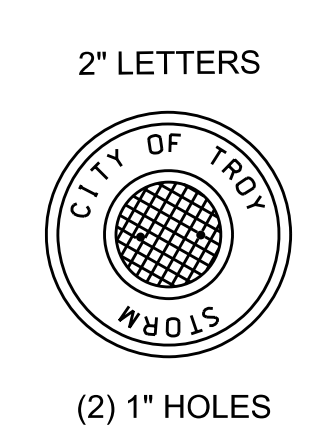

- The contractor shall provide a 3 year maintenance and guarantee bond to the City, dated from the time of final acceptance by the City. The bond amount shall be 35% of constructions costs.
- Before final acceptance, As-Built drawings must be submitted to the City of Troy Engineering Department. One electronic copy (PDF) and one digital copy (DWG or DGN) is required. .

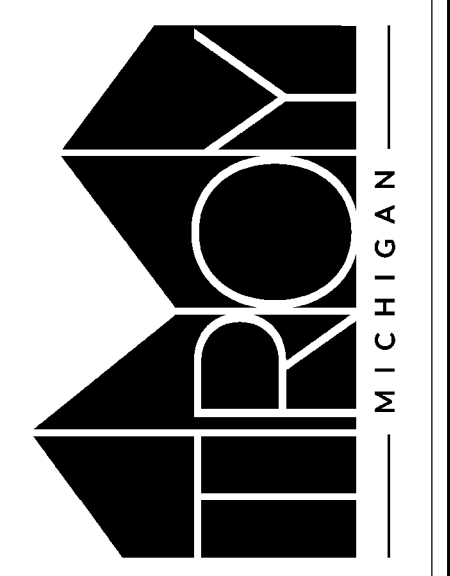

STANDARD STORM SEWER DETAILS
ENGINEERING DEPARTMENT

APPROVED BY: WILLIAM J. HUOTARI, CITY ENGINEER
DATE: JUNE 2019

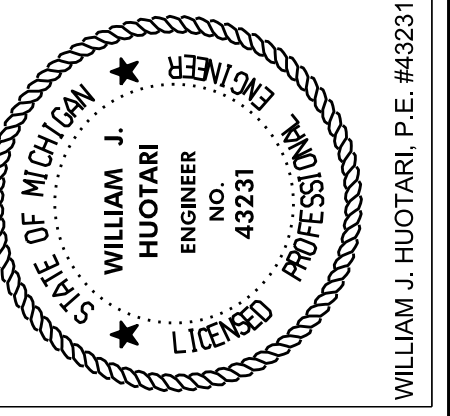

3 FULL WORKING DAYS BEFORE YOU DIG CALL 811

Contractor Note: The locations of existing underground utilities are shown on the plans. The contractor shall determine the exact location of all existing utilities before commencing work. They agree to be fully responsible for any damages which might be occasioned by their failure to exactly locate and preserve any and all underground utilities.

CONTRACT NO. XX-XX
PROJECT NO. XX-XXX-X

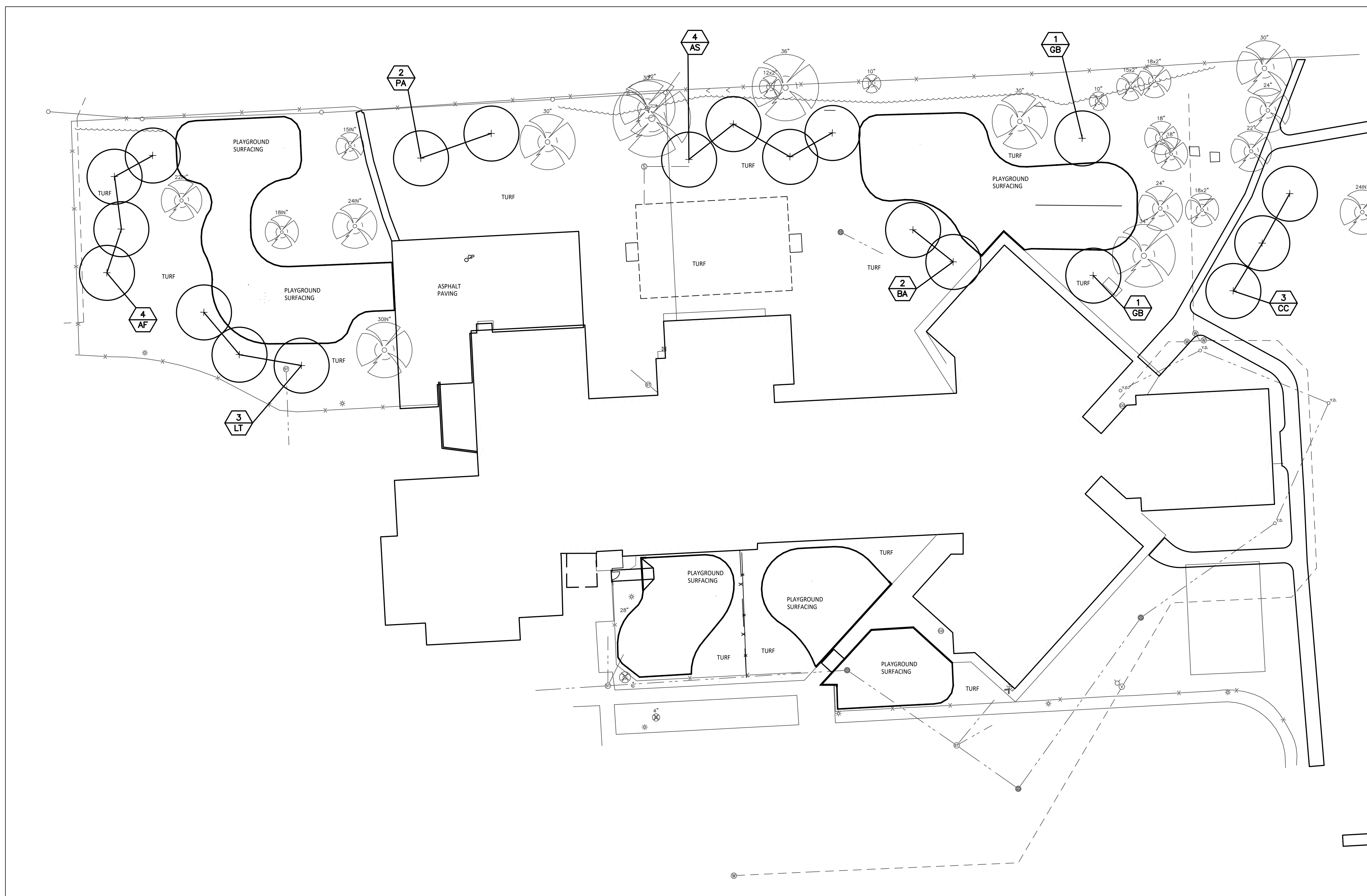

1 Overall Landscape Plan
Scale = 1"=30'-0"

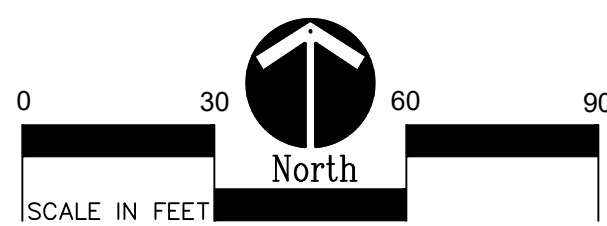

LANDSCAPE NOTES:

1. SURVEY OF EXISTING CONDITIONS PROVIDED BY PEA GROUP, 1849 POND RUN, AUBURN HILLS, MICHIGAN, 48326, (248)689-9090.
2. CALL "MISS DIG" AND VERIFY ALL UNDERGROUND UTILITIES PRIOR TO BEGINNING WORK. 72 HOURS BEFORE YOU DIG CALL "MISS DIG" AT 1-800-482-7371. ANY UTILITIES DISTURBED BY CONSTRUCTION SHALL BE REPAIRED AT CONTRACTOR'S EXPENSE.
3. ANY DISCREPANCIES BETWEEN THESE PLANS AND ACTUAL FIELD CONDITIONS SHOULD BE REPORTED TO THE CONSTRUCTION MANAGER IMMEDIATELY FOR RESOLUTION.
4. IN AREAS OF NEW TURF PLACE 4" MINIMUM TOPSOIL, FINE GRADE & ESTABLISH TURF WITHIN SEED LIMIT LINES.
5. PLACE SHREDDED HARDWOOD MULCH TO A 3" DEPTH IN ALL TREE & SHRUB BEDS & TO A 2" DEPTH IN ALL GROUND COVER BEDS.
6. UNLESS OTHERWISE NOTED, TOPSOIL, FINE GRADE AND SEED ALL DISTURBED AREAS WITHIN THE SEEDING LIMIT SHOWN AND AREAS DISTURBED BY CONSTRUCTION.
7. REPAIR AND RESTORE ANY DAMAGE OUTSIDE OF LIMIT OF WORK LINE TO ORIGINAL CONDITION.
8. PROTECT ALL TREES AND EXISTING FEATURES TO REMAIN AS SPECIFIED.
9. ALL TOPSOIL AND EXCESS FILL MATERIAL SHALL BE STOCKPILED ON SITE SEPARATELY FOR LATER RE-USE. LOCATE STOCKPILES IN AREAS AS DIRECTED BY CONSTRUCTION MANAGER AND PROTECT FROM EFFECTS OF EROSION.
10. ALL NURSERY STOCK SHALL BE TRUE TO TYPE AND NAME. ALL STOCK SHALL BE FIRST CLASS QUALITY WITH WELL DEVELOPED BRANCH SYSTEMS AND VIGOROUS HEALTHY ROOT SYSTEMS. ALL STOCK SHALL BE WELL FORMED AND THE TRUNKS OF TREES SHALL BE UNIFORM AND STRAIGHT.
11. CONTRACTOR RESPONSIBLE TO LOCATE SITE LIGHTING SERVICES. CONTRACTOR RESPONSIBLE TO NOTIFY CONSTRUCTION MANAGER IF DAMAGE TO LIGHTING ELECTRICAL DISTRIBUTION OCCURS.
12. ALL AREAS OF TREE CLEARING SHALL BE STAKED FOR ARCHITECTS APPROVAL PRIOR TO CLEARING.
13. UNLESS OTHERWISE SPECIFIED, ALL PERENNIALS, GRASSES AND GROUNDCOVERS SHALL BE GROWN IN THEIR CONTAINER FOR ONE YEAR PRIOR TO INSTALLATION.

PROPOSED FEATURES LEGEND:

SYMBOL	DESCRIPTION	DETAIL
(Circle with +)	DECIDUOUS TREE	2 & 3/1.0
(Dashed line)	LIMIT OF WORK	
(Long dashed line)	PROPERTY LINE	
(Hexagon with symbol)	PLANT TAG- REFERS TO TYPE AND NUMBER OF PLANTINGS TO BE PROVIDED AND MAINTAINED BY CONTRACTOR.	



REGISTRATION SEAL

CONSULTANT

OCBA LANDSCAPE ARCHITECTS

350 East Michigan Avenue Suite #415
Kalamazoo Michigan 49007
Phone (269) 381-3357
Fax (269) 381-2944

PROJECT TITLE
Morse Elementary School Playground Renovation Bld Package No.01A

Troy School District Troy, Michigan

DRAWING TITLE
Overall Landscape Plan

PLANT LIST:

TREES	SYM.	BOTANICAL NAME	COMMON NAME	SIZE	ROOT	SPACING	STATUS
	AF	<i>Acer x freemanii 'Marmo'</i>	Marble Freeman Maple	2" CAL	888	PER PLANS	NATIVE
	AS	<i>Acer saccharum 'Commemorator'</i>	Commemoration Sugar Maple	2" CAL	888	PER PLANS	NATIVE
	BA	<i>Betula alleghaniensis</i>	Yellow Birch	2" CAL	888	PER PLANS	NATIVE
	CC	<i>Carpinus caroliniana</i>	Hornbeam	2" CAL	888	PER PLANS	NATIVE
	GB	<i>Ginkgo biloba 'Autumn Gold'</i>	Autumn Gold Ginkgo Tree (no female)	2" CAL	888	PER PLANS	NON-NATIVE
	PA	<i>Platanus x acerifolia 'Bloodgood'</i>	London Planetree	2" CAL	888	PER PLANS	NON-NATIVE
	LT	<i>Liriodendron tulipifera</i>	Tulip Tree	2" CAL	888	PER PLANS	NATIVE

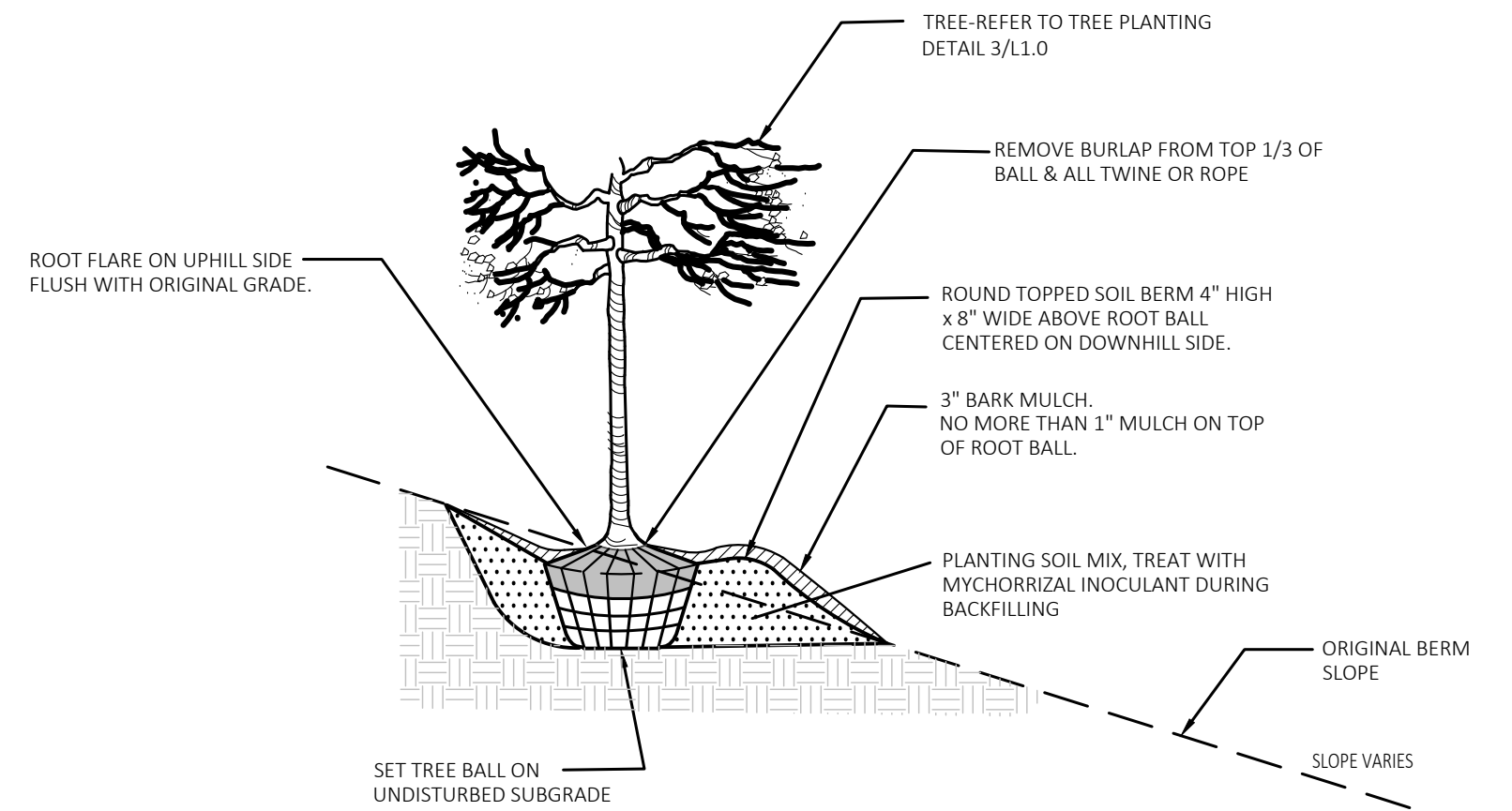

2 Tree On Berm Detail 1/4 Slope or Greater
NOT TO SCALE

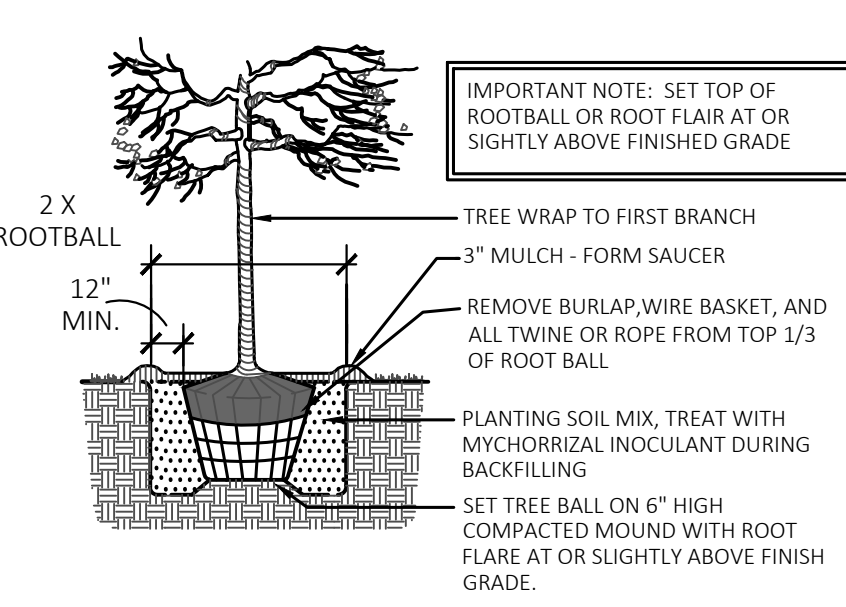

3 Tree Planting Detail
NOT TO SCALE

ISSUE DATES

DATE	ISSUED FOR

11-09-23 CONSTRUCTION DOCUMENTS

DATE: ISSUED FOR:

DRAWN: ...

CHECKED: ...

APPROVED: ...

PROJECT NO.
22093B

DRAWING NO.
L1.0