

---

# TABLE OF CONTENTS

## INTRODUCTION

Terms and Conditions	2
Standard Fabrics	4
Non-Standard Fabrics	5
Standard Finishes	6
Trim/End Panel/Panel Glazing	7
Pull Options	8
Panel Options	9
Grommet Locations	10

## MONOLITHIC PANELS

Monolithic Hard Surface Panel	
Non-Electrical	12
Electrical	14
Monolithic Hard Surface Partial-Glazed	
Non-Electrical	16
Electrical	17
Monolithic Fabric-Covered Panel	
Non-Electrical	18
Electrical	20
Monolithic Partial Glazed Panel	
Non-Electrical	22
Electrical	23

## SEGMENTED PANELS

Specification Guide	26
Design 1 & 2 Segmented Panel Kit	26
Design 1 & 2 Segments	27
Design 1 Segmented Panels	28
Design 2 Segmented Panels	29
Design 1 Segmented Panel	30
Design 2 Segmented Panel	32

## DOOR FRAMES

Door Frames	34
-------------	----

## PANEL HARDWARE

Draw Rod	35
Connectors	36

## ELECTRICAL DISTRIBUTION

Electrical Distribution	39
-------------------------	----

## WORKSURFACES

Rectangular	42
Wedge	43
90° Notched and Curved Corner	44
Square Edge Half Circle	45
Square Edge D-Shaped	46
90° Extended Notched Corner	47
90° Extended Curved Corner	50
90° Ext Notched Corner Peninsula	53
Ext Curved Corner Peninsula	57
Ext Curved Corner P-Shape Peninsula	61
Ellipse End Peninsula	63
Rectangular Asymmetrical	64
120° Rectangular	65
120° Corner / 90° Ends	66
120° Corner / 120° Ends	67
135° Corner	68
135° Double Corner	69
Transaction Surface	70
Corner Transaction	71
<b>MY-HITE WORKSURFACES</b>	
Rectangular	72
Corner	73
90° Extended Curved Corner	74
D-Shaped	77
Wedge	78
120° Corner / 90° Ends	79
120° Corner / 120° Ends	79
Grommets	80
Flat Bracket	81
Supports	82

## COMPONENTS

Components	85
Frameless Glass	
Clear	86
Frosted	87
Privacy Screen, Fabric	88
Privacy Screen, Marker Board	89
Privacy Screen, Laminate	90
Modesty Panel, Laminate	91
Tackboards	92
Markerboards	93
Overheads and Shelves	94

## STORAGE

Pedestals	96
Lateral Files	99
Freestanding Credenza Units	101
Freestanding Credenza Units	103
Freestanding Towers	105

## PULLS

Pulls	
Lateral	107
Pedestal	108

## ACCESSORIES

Accessories	109
Keyed-Alike Information	110

---

## Terms and Conditions

### PRICES

All Prices are F.O.B. point (Continental U.S.). We reserve the right to change prices without prior notice.

### ORDERING

Purchase Orders should be sent to Friant & Associates, LLC at orders@friant.com, or faxed to (510) 535-6895. If your specifications were created with CAP, GIZA, or Project Matrix please send the worksheet (SP4) with your Purchase Order.

### TERMS

Net 30 days from date of invoice. Invoices are delinquent if not paid 30 days from date of invoice. In the event timely payment is not made, interest will be charged at the rate of 1.5% per month on delinquent accounts. Buyers will also be liable for normal collection costs and attorney's fee. 50% deposit is required with every order, unless prior arrangements have been made.

### ORDERS

Orders are only accepted by issuance of our formal acknowledgment, and are subject to the terms set forth herein and on our order acknowledgment. It is the responsibility of the buyer to review our acknowledgment for its accuracy, and to notify Friant within 48 hours from the date of the acknowledgment of any discrepancies.

### LEAD TIME

Lead times are subject to availability.

### SHIPPING

Friant generally palletizes, boxes and/or shrink-wraps its products. If buyer requests additional packaging or special shipping, then it is responsible for any extra costs that result. Buyer obtains title to products and assumes the risk of loss for them upon shipment from Friant's plant.

### CLAIMS

We are not responsible for damage suffered in transit. Merchandise should be inspected for possible freight damage upon delivery. The consignee should file for damage or shortages with the carrier within 5 days of delivery. You are also protected for "concealed damage" if you file claim with the carrier within 5 days of delivery. Buyer must make all claims against Friant for defects, errors or shortages in writing within 10 days after delivery. Failure to make such a claim shall constitute full acceptance.

### RETURNS

No merchandise may be returned without our written consent and shipping instructions. Unauthorized returns will not be accepted and will be returned freight collect.

### PARTIAL SHIPMENTS

We will make every attempt to ship orders complete and on schedule. However, we reserve the right to make partial shipments, as merchandise is ready. Invoices covering these shipments are to be paid as they become due.

### ORDER CHANGE — CANCELLATIONS

Our order confirmation is final and binding. Any order change or cancellation is subject to our ability to conform. Such requests are to be made in writing to our office.

### SHIPMENT AND PREPAID FREIGHT

Unless otherwise instructed, we reserve the option to ship by what is, in our opinion, the best possible way. Upon request, we will prepay and add freight for accounts with established credit.

### DELIVERY

We are not liable for delay or failure of delivery due to strikes and/or differences with workmen, war, riot, fire, compliance with government regulations, acts of nature, failure or delays of sources of supply, or any other causes beyond our control.

### STORAGE

If buyer cannot accept delivery when merchandise is ready, we reserve the right to transfer goods to storage. Costs of transfer and storage will be charged to the buyer's account, and we will deem such transfer as constituting shipment for all purposes, including invoicing, as of the date the transfer is made.

## Terms and Conditions continued

### CONSTRUCTION – SPECIFICATIONS

All items are produced to price list specifications unless otherwise advised. All dimensions shown are approximate. Manufacturer reserves the right to make modifications and/or improvements without prior notice.

### FABRIC APPLICATION

Standard fabric application for panels 67" and below is horizontal application. Panels taller than 67" are only available in vertical application. When ordering panels 67" and below to match a panel taller than 67", specify vertical application. Please note: Some patterns require horizontal or vertical application specifically tailored to those products. See individual pricebook specifications for details.

Friant & Associates is not responsible for charges associated with replacement of products due to incorrect specifications.

### CUSTOMER'S OWN MATERIAL

Yardage requirement is based on 66" wide plain covering material, and must be increased if less than 66" wide. Special instructions for handling material (pattern, directional fabric, right side of reversible fabric, etc.) must be submitted in writing before fabric is delivered. In the absence of special instructions, we reserve the right to use our own judgment. We reserve the right to reject any covering, which in our opinion, is unsuitable for our upholstery purposes. However, in no instance shall we be held responsible for unsatisfactory results due to use of covering unsuitable for our upholstery methods.

We will not be responsible for errors caused by buyers not supplying us with sample cuttings attached to their order giving full identification of covering material, (name of supplier, covering name, number and color) for identification purposes and advising us of model number and quantity to which each cover is to be applied.

Customer's own material that is shipped freight collect will be refused. A service charge will be applied for the return of unusable C.O.M. Contact factory.

### RIGHTS AND WARRANTIES – LIMITED LIFETIME WARRANTY

This warranty is given to the initial purchaser and is valid from the date of purchase, for as long as the initial purchaser owns the product. This warranty covers defects in material and craftsmanship found during normal usage of the product during the warranty period. If the product is defective, and if written notice of the defect is given to Friant & Associates within the applicable warranty period, Friant & Associates, at its option, will either repair or replace the defective product with a comparable component or product. This warranty applies to all products except as noted below.

High wear parts, such as wood veneer, fabrics, laminates and other covering material/finishes, foam, glides, etc. are warranted for one (1) year. This warranty does not apply to damage caused by a carrier, alteration to the product not expressly authorized by Friant & Associates, nor to product considered to be of a consumable nature such as bulbs, light ballasts, etc. It also does not apply to "Customer's Own Material" (i.e. material specified by the customer that is not a standard Friant & Associates offering) used in the manufacture of Friant & Associates products.

Friant & Associates does not warrant the matching of colors, grain or texture, except to within commercially acceptable standards. This includes normal variations between dye lots (fabrics).

A product will not be considered defective, and Friant & Associates will not be obligated to replace it, if it is not installed in a proper manner (i.e. product not leveled, not secured properly, etc.).

Except as noted above, Friant & Associates makes no express or implied warranties to any product, and in particular makes no warranty of fitness for any particular use. At Friant & Associates' option, product repair and replacement is the customer's exclusive remedy for any and all product defects.

Friant & Associates shall not be liable for consequential, economic, or incidental damages arising from any product defect.

### CALIFORNIA PROP 65 WARNING

Products in this catalog may contain a chemical known to the state of California to cause cancer, or birth defects or other reproductive harm.

## Standard Fabrics & Tile Application

### Standard Panel Fabrics

#### NON-DIRECTIONAL FABRIC APPLICATION

SLIDE		SILKY		STICKS	
PF101-1	Caramel	PF401-1	Natural	PF501-1	Smoke
PF101-2	Slate	PF401-2	Parids	PF501-2	Almond
PF101-3	Pewter	PF401-3	Overcast	PF501-3	Sage
PF101-4	Verde	PF401-4	Field	PF501-4	Straw
PF101-5	Twilight	PF401-5	Graphite		
PF101-6	Vintage				
PF101-7	Java				
PF101-8	Latte			SKY	
PF101-9	Sterling				
PF101-10	Crema			PF301-1	Terra
PF101-11	Breeze			PF301-2	Birch
PF101-12	Stem			PF301-3	Moss

#### DIRECTIONAL FABRIC APPLICATION

PASSAGE		TERRAIN		EXCEPTIONS
PF601-1	Gull	PF701-1	Cloud	<b>MONOLITHIC PANELS 85"</b>
PF601-2	Grove	PF701-2	Dusk	ALL SLIDE
PF601-3	Wing	PF701-3	Wave	ALL SILKY
PF601-4	Quartz	PF701-4	Earth	ALL STICKS
PF601-5	Leaf			ALL SKY
PF601-6	Brook			ALL TERRAIN
PF601-7	Trail			ALL PASSAGE
PF601-8	Amber			

**NOTES:** Additional fabrics are available for an upcharge. Contact our Customer Service for pricing.

Standard fabric application for panels 67" and below is horizontal application as per graphic). **85"H panels are only available in vertical application. When ordering panels 67" and below to match an 85"H panel, specify vertical application.**

Order fabric cards online at [www.friant.com/samples](http://www.friant.com/samples).

Colors may vary slightly between dye lots.

---

## Non-Standard Fabrics & Tile Application

### CUSTOMER'S OWN MATERIAL

Yardage requirement is based on 66" wide plain covering material, and must be increased if less than 66" wide. Special instructions for handling material (pattern, directional fabric, right side of reversible fabric, etc.) must be submitted in writing before fabric is delivered. In the absence of special instructions, we reserve the right to use our own judgment. We reserve the right to reject any covering, which in our opinion, is unsuitable for our upholstery purposes. However, in no instance shall we be held responsible for unsatisfactory results due to use of covering unsuitable for our upholstery methods.

We will not be responsible for errors caused by buyers not supplying us with sample cuttings attached to their order giving full identification of covering material, (name of supplier, covering name, number and color) for identification purposes and advising us of model number and quantity to which each cover is to be applied.

Customer's own material that is shipped freight collect will be refused. A service charge will be applied for the return of unusable C.O.M. Contact factory.

**NOTES:** Additional fabrics are available for an upcharge. Contact our Customer Service for pricing.

Order fabric cards online at [www.friant.com/samples](http://www.friant.com/samples).

Colors may vary slightly between dye lots.

### FABRIC DIRECTION

All tex listed are 66" wide, with the following icons used to denote the direction of which the fabric is applied. Any variations in the direction of fabric application will be noted by use of the icon and on which pieces the variation be used.

## Standard Finishes

### WORKSURFACE FINISHES

M1	Light Maple	CW grommets
M2	Light Cherry	BU grommets
M3	Medium Cherry	BU grommets
M4	Dark Mahogany	BU grommets
M5	Light Mahogany	BU grommets
M6	Light Gray	CW grommets
M7	Off White	CW grommets
M8	Gray Specks	CW grommets
M9	Cloud White	CW grommets
M10	Espresso	BU grommets
M11	Light Walnut	CW grommets
M12	Medium Walnut	BU grommets
M13	Licorice	BU grommets
M14	Carob	BU grommets
M15	Mousse	BU grommets
M16	Tundra	CW grommets
M17	Cocoa	BU grommets
M18	Capitan	BU grommets
M19	Fog	CW grommets
M20	Sandstone	BU grommets
M21	Medium Oak	BU grommets
M22	Harbor	BU grommets
M23	Bark	BU grommets
M24	Tarmac	BU grommets
M25	Winter	CW grommets
M26	Storm	BU grommets
M27	Medium Ash	BU grommets
M28	Arctic	CW grommets
M29	Raven	BU grommets

Note: Default grommets are CW or BU.  
Order grommet cover separately for other color.

Note: When pairing a laminate worksurface finish with hardsurface panel finish, there may be small difference. Contact your sales rep for details.

### HARDSURFACE PANEL FINISHES

7909-60	Fusion Maple
7054-60	Wild Cherry
7924K-70	Biltmore Cherry
7040K-60	Figured Mahogany
7039K-78	Windsor Mahogany
D327-60	Pepperdust
1572-60	Antique White
4621-60	White Nebula
1573-60	Frosty White
7933K-07	Cafelle
7937-60	River Cherry
7965L-12	Walnut Heights
FB3920	Licorice Groovz
FB3560	Driftwood
FB2960	Mochatini
FB3930	Concrete Groovz
FB2990	Nirvana
FB3400	Aria
FB2100	Silver Frost
FB2090	Shadow Frost
FB2030	Seria
FB4310	Umbra
FB3970	Stromboli
FB4320	Ashen
FB2130	Fog Grey
FB2000	Pewter Frost
8842	Weathered Ash
8841	White Ash
1595-60	Black

These are the standard laminates offered for hardsurface panels and laminate end panels (ending in -LAM). See page 81)

Additional charge to use Hardsurface Panel Finishes on worksurfaces.

### EDGE FINISHES (3MM PVC)

E1	Light Maple
E2	Light Cherry
E3	Medium Cherry
E4	Dark Mahogany
E5	Light Mahogany
E6	Light Gray
E7	Off White
E8	Black Umber
E9	Cloud White
E10	Espresso
E11	Medium Tone
E12	Dark Tone
E13	Licorice
E14	Light Walnut
E15	Medium Walnut
E17	Carob
E18	Mousse
E19	Tundra
E20	Cocoa
E21	Capitan
E22	Fog
E23	Sandstone
E24	Medium Oak
E25	Harbor
E26	Bark
E27	Tarmac
E28	Winter
E29	Storm
E30	Medium Ash
E31	Arctic
E32	Raven

---

## Trim/End Panel/Panel Glazing

### PAINT TRIM

DT Dark Tone  
MT Medium Tone  
CW Cloud White  
SV Silver

### END PANEL - MEL (See page 81)

DT Dark Tone  
MT Medium Tone  
CW Cloud White

### PANEL GLAZING

TR Clear  
FR Frosted (Contact Customer Service  
for leadtime)

**NOTE:** For information on LEED or environmental information about our products, contact our Design department at [spec@friant.com](mailto:spec@friant.com) or visit our website at [www.friant.com/environment](http://www.friant.com/environment).

## Credenza, Pedestal, Lateral File and Freestanding Tower Handles

You have multiple handle options for handles for your FRIANT storage. Please specify which handle you would like when ordering. For any questions, please call Friant Customer Service or your sales rep.

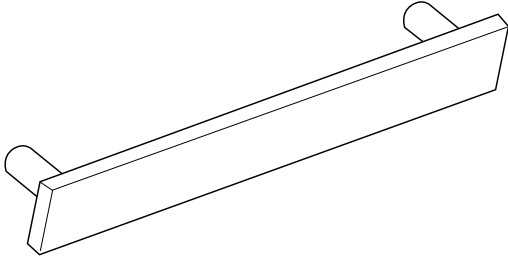

### BAR PULL

Available in brushed metal

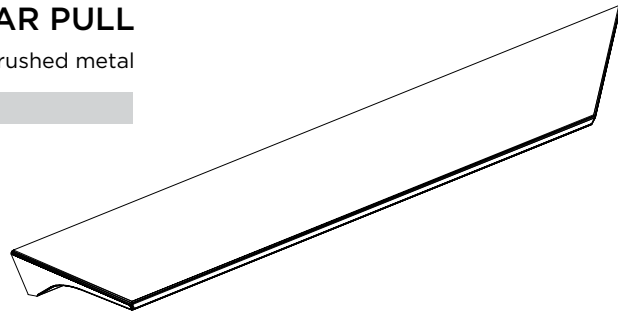

### WEDGE PULL

Available in brushed metal

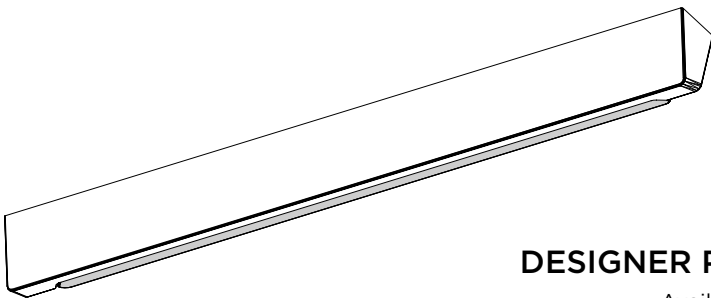

### DESIGNER PULL

Available in:  
Cloud White/Red, Cloud White/Green, Cloud White/Grey

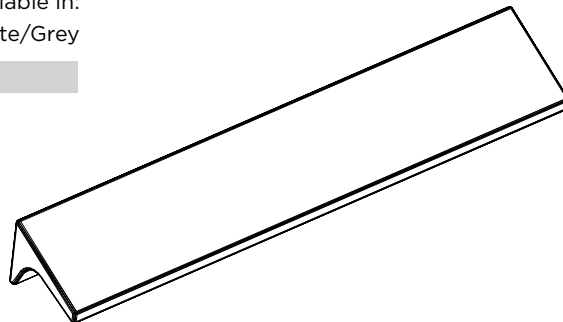

### SLANT PULL

Available in brushed metal



# Panel Options

The Novo system offers two categories of panels: monolithic and segmented.

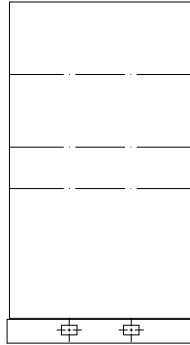
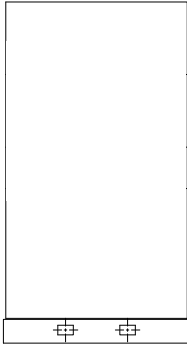

**MONOLITHIC**  
Fabric Covered or  
Partial Glazed

**SEGMENTED**  
Design 1 or Design 2  
see 25

All panels are available electrical or non-electrical.  
For Monolithic Panels, see 11  
For Segmented Panels, see 25 for spec guide and pages 11-32 for ordering.

# Panel Creep

**2-WAY**

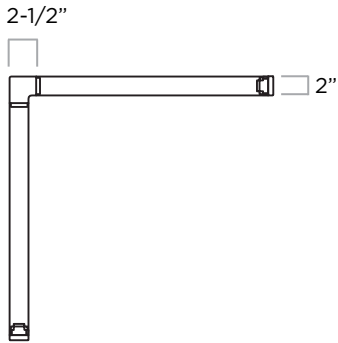

**3-WAY**

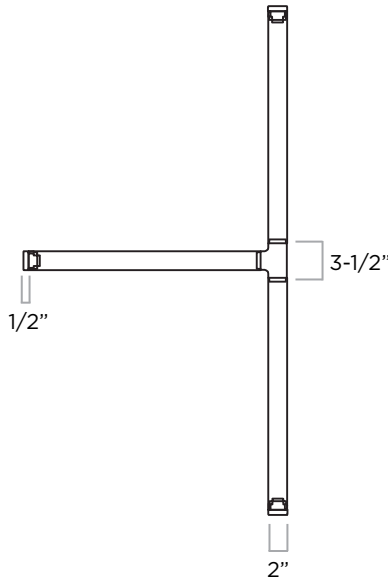

**4-WAY**

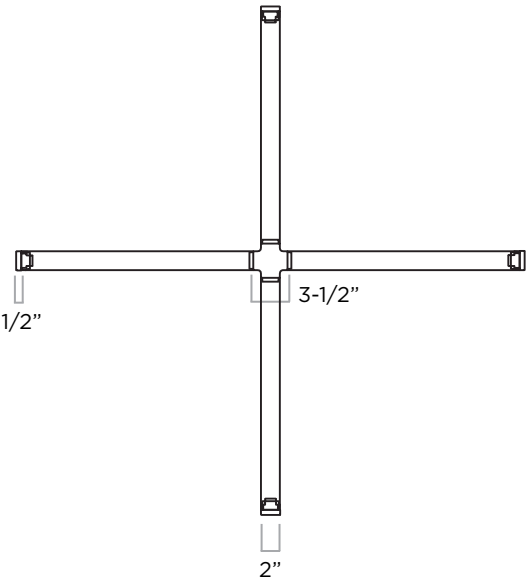

## Grommet Locations

### 1 Select a My-Hite worksurface

My-Hite tops (located on page 72) have optional grommets. Please use the two letter codes shown here when specifying location of grommets.

Grommets are 3" round with cover standard.

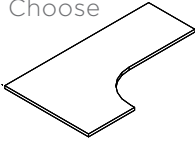
Choose 	Specify Part # FDECCWS.23345823R	Specify Finish Bark
---	-------------------------------------	------------------------

### 2 Select a grommet location

Specify positioning by using the two letter location.

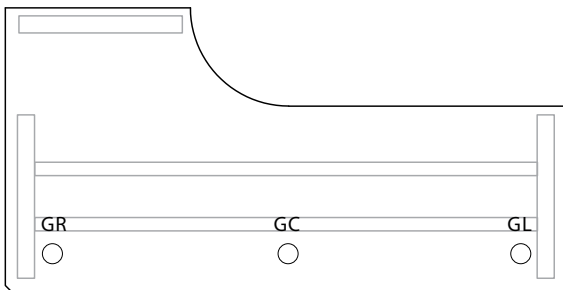
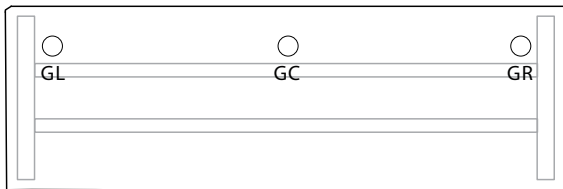
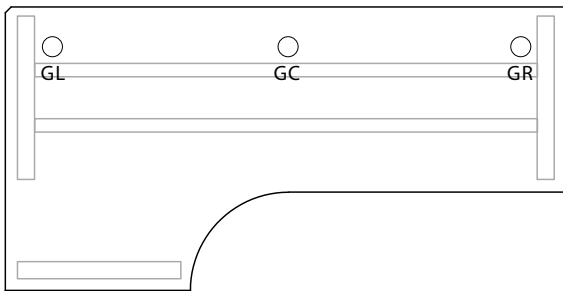

CODE	POSITION
GL	4" from left side - 4" from rear
GR	4" from right side - 4" from rear
GC	Centered from side to side - 4" from rear

Dimensions are measured from grommet center to top edge:

For other grommet locations, please call Friant customer service.

Please Note: Only the GC location is available on the D-Shaped worksurface.

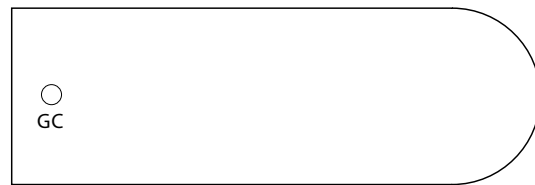

# MONOLITHIC PANELS

## Monolithic Hard Surface Panel Non-Electrical

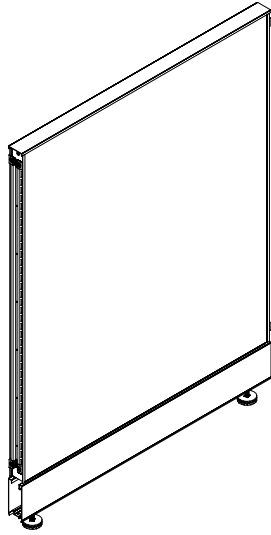

### DESCRIPTION

Structural panel with laminate surfaces, painted top caps and trim, leveling glides, and cable management side covers.

### NOTES

- Order connectors and finished ends separately
- Add an additional 2 weeks to the standard lead time for laminate panels
- For matching worksurface to hardsurface panel, see page 6

### SPECIFICATION OPTIONS

**product #:** see charts below  
**finish:** DT Dark Tone, MT Medium Tone, CW Cloud White  
**laminate (side 1):** see page 6  
**laminate (side 2):** see page 6

### ORDER EXAMPLE

**product #:** FHHSPA.3924N  
**finish:** DT  
**laminate (side 1):** FB2960 Mochatini  
**laminate (side 2):** FB3400 Aria

### 39" HIGH

PART #	HEIGHT	WIDTH	DEPTH	WT. (LBS)	LIST
FHHSPA.3924N	39"	24"	2"	26	\$641
FHHSPA.3930N	39"	30"	2"	27	\$764
FHHSPA.3936N	39"	36"	2"	31	\$881
FHHSPA.3942N	39"	42"	2"	36	\$960
FHHSPA.3948N	39"	48"	2"	39	\$988

### NOTES

- For matching worksurface to hardsurface panel, see page 6

### 47" HIGH

PART #	HEIGHT	WIDTH	DEPTH	WT. (LBS)	LIST
FHHSPA.4724N	47"	24"	2"	29	\$680
FHHSPA.4730N	47"	30"	2"	33	\$807
FHHSPA.4736N	47"	36"	2"	38	\$927
FHHSPA.4742N	47"	42"	2"	41	\$979
FHHSPA.4748N	47"	48"	2"	47	\$1,012

### NOTES

- For matching worksurface to hardsurface panel, see page 6

### 53" HIGH

PART #	HEIGHT	WIDTH	DEPTH	WT. (LBS)	LIST
FHHSPA.5324N	53"	24"	2"	32	\$693
FHHSPA.5330N	53"	30"	2"	38	\$822
FHHSPA.5336N	53"	36"	2"	41	\$950
FHHSPA.5342N	53"	42"	2"	44	\$1,030
FHHSPA.5348N	53"	48"	2"	51	\$1,060

### NOTES

- For matching worksurface to hardsurface panel, see page 6

**67" HIGH**

PART #	HEIGHT	WIDTH	DEPTH	WT. (LBS)	LIST
FHHSPA.6724N	67"	24"	2"	40	\$916
FHHSPA.6730N	67"	30"	2"	46	\$1,062
FHHSPA.6736N	67"	36"	2"	51	\$1,229
FHHSPA.6742N	67"	42"	2"	57	\$1,360
FHHSPA.6748N	67"	48"	2"	64	\$1,394

**NOTES**

- For matching worksurface to hardsurface panel, see page 6

**85" HIGH**

PART #	HEIGHT	WIDTH	DEPTH	WT. (LBS)	LIST
FHHSPA.8524N	85"	24"	2"	50	\$1,147
FHHSPA.8530N	85"	30"	2"	58	\$1,378
FHHSPA.8536N	85"	36"	2"	65	\$1,599
FHHSPA.8542N	85"	42"	2"	73	\$1,760
FHHSPA.8548N	85"	48"	2"	81	\$1,814

**NOTES**

- For matching worksurface to hardsurface panel, see page 6

## Monolithic Hard Surface Panel Electrical

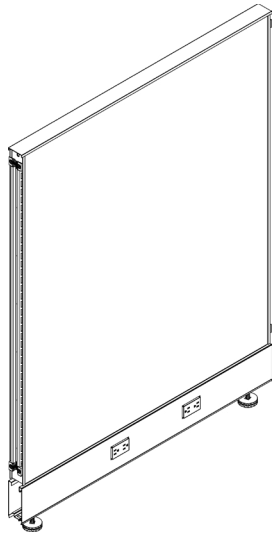

### DESCRIPTION

Structural panel with laminate surfaces, painted top caps and trim, leveling glides, 4-circuit power installed in cable management raceway covers.

### NOTES

- 24" wide panels have one receptacle per side
- 30" to 48" wide panels have two receptacle locations per side
- Order receptacles separately
- Includes panel to panel festoon
- Order panel through post festoon separately
- Order connectors and finished ends separately
- Add an additional 2 weeks to the standard lead time for laminate panels
- For matching worksurface to hardsurface panel, see page 6

### SPECIFICATION OPTIONS

**product #:** see charts below

**finish:** DT Dark Tone, MT Medium Tone, CW Cloud White

**laminate (side 1):** see page 6

**laminate (side 2):** see page 6

### ORDER EXAMPLE

**product #:** FHHSPA.3924E

**finish:** DT

**laminate (side 1):** FB2960 Mochatini

**laminate (side 2):** FB3400 Aria

### 39" HIGH

PART #	HEIGHT	WIDTH	DEPTH	WT. (LBS)	LIST
FHHSPA.3924E	39"	24"	2"	27	\$771
FHHSPA.3930E	39"	30"	2"	29	\$917
FHHSPA.3936E	39"	36"	2"	33	\$1,050
FHHSPA.3942E	39"	42"	2"	38	\$1,150
FHHSPA.3948E	39"	48"	2"	42	\$1,199

### NOTES

- For matching worksurface to hardsurface panel, see page 6

### 47" HIGH

PART #	HEIGHT	WIDTH	DEPTH	WT. (LBS)	LIST
FHHSPA.4724E	47"	24"	2"	30	\$810
FHHSPA.4730E	47"	30"	2"	35	\$960
FHHSPA.4736E	47"	36"	2"	40	\$1,097
FHHSPA.4742E	47"	42"	2"	43	\$1,169
FHHSPA.4748E	47"	48"	2"	50	\$1,223

### NOTES

- For matching worksurface to hardsurface panel, see page 6

### 53" HIGH

PART #	HEIGHT	WIDTH	DEPTH	WT. (LBS)	LIST
FHHSPA.5324E	53"	24"	2"	33	\$825
FHHSPA.5330E	53"	30"	2"	40	\$974
FHHSPA.5336E	53"	36"	2"	43	\$1,118
FHHSPA.5342E	53"	42"	2"	47	\$1,220
FHHSPA.5348E	53"	48"	2"	53	\$1,270

### NOTES

- For matching worksurface to hardsurface panel, see page 6

**67" HIGH**

PART #	HEIGHT	WIDTH	DEPTH	WT. (LBS)	LIST
FHHSPA.6724E	67"	24"	2"	41	\$1,047
FHHSPA.6730E	67"	30"	2"	47	\$1,216
FHHSPA.6736E	67"	36"	2"	53	\$1,398
FHHSPA.6742E	67"	42"	2"	59	\$1,550
FHHSPA.6748E	67"	48"	2"	67	\$1,605

## NOTES

- For matching worksurface to hardsurface panel, see page 6

**85" HIGH**

PART #	HEIGHT	WIDTH	DEPTH	WT. (LBS)	LIST
FHHSPA.8524E	85"	24"	2"	50	\$1,279
FHHSPA.8530E	85"	30"	2"	59	\$1,532
FHHSPA.8536E	85"	36"	2"	67	\$1,768
FHHSPA.8542E	85"	42"	2"	75	\$1,950
FHHSPA.8548E	85"	48"	2"	84	\$2,023

## NOTES

- For matching worksurface to hardsurface panel, see page 6

## Monolithic Hard Surface Partial-Glazed Panel Non-Electrical

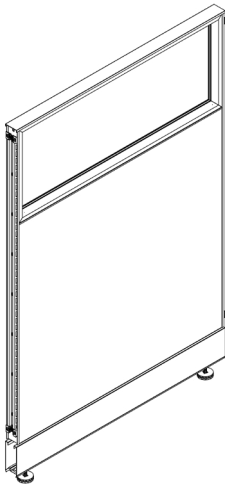

### DESCRIPTION

Structural panel with laminate lower surfaces and 14" high tempered glass top section, painted top caps and trim, leveling glides, and cable management side covers.

### NOTES

- Order connectors and finished ends separately
- Add an additional 2 weeks to the standard lead time for laminate panels
- Cannot be used as dry erase surface
- For matching worksurface to hardsurface panel, see page 6

### SPECIFICATION OPTIONS

**product #:** see charts below

**finish:** DT Dark Tone, MT Medium Tone, CW Cloud White

**panel glazing:** TR Clear, FR Frosted

**laminate (side 1):** see page 6

**laminate (side 2):** see page 6

### ORDER EXAMPLE

**product #:** FHPGHSPA.5324N

**finish:** DT

**panel glazing:** TR Clear

**laminate (side 1):** FB2960 Mochatini

**laminate (side 2):** FB3400 Aria

### 53" HIGH

PART #	HEIGHT	WIDTH	DEPTH	WT. (LBS)	LIST
FHPGHSPA.5324N	53"	24"	2"	32	\$979
FHPGHSPA.5330N	53"	30"	2"	38	\$1,108
FHPGHSPA.5336N	53"	36"	2"	41	\$1,236
FHPGHSPA.5342N	53"	42"	2"	44	\$1,316
FHPGHSPA.5348N	53"	48"	2"	51	\$1,346

### NOTES

- For matching worksurface to hardsurface panel, see page 6

### 67" HIGH

PART #	HEIGHT	WIDTH	DEPTH	WT. (LBS)	LIST
FHPGHSPA.6724N	67"	24"	2"	40	\$1,202
FHPGHSPA.6730N	67"	30"	2"	46	\$1,348
FHPGHSPA.6736N	67"	36"	2"	51	\$1,515
FHPGHSPA.6742N	67"	42"	2"	57	\$1,646
FHPGHSPA.6748N	67"	48"	2"	64	\$1,680

### NOTES

- For matching worksurface to hardsurface panel, see page 6

### 85" HIGH

PART #	HEIGHT	WIDTH	DEPTH	WT. (LBS)	LIST
FHPGHSPA.8524N	85"	24"	2"	50	\$1,433
FHPGHSPA.8530N	85"	30"	2"	58	\$1,664
FHPGHSPA.8536N	85"	36"	2"	65	\$1,885
FHPGHSPA.8542N	85"	42"	2"	73	\$2,046
FHPGHSPA.8548N	85"	48"	2"	81	\$2,100

### NOTES

- For matching worksurface to hardsurface panel, see page 6



## Monolithic Hard Surface Partial-Glazed Panel Electrical

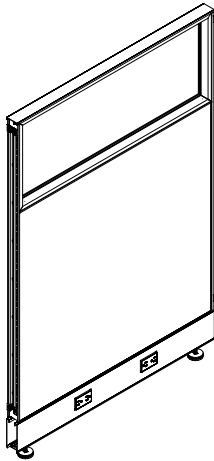

### DESCRIPTION

Structural panel with laminate lower surfaces and 14" high tempered glass top section, painted top caps and trim, leveling glides, 4-circuit power installed in cable management raceway covers.

### NOTES

- 24" wide panels have one receptacle per side
- 30" to 48" wide panels have two receptacle locations per side
- Order receptacles separately
- Includes panel to panel festoon
- Order panel through post festoon separately
- Order connectors and finished ends separately
- Add an additional 2 weeks to the standard lead time for laminate panels
- Cannot be used as dry erase surface
- For matching worksurface to hardsurface panel, see page 6

### SPECIFICATION OPTIONS

**product #:** see charts below  
**finish:** DT Dark Tone, MT Medium Tone, CW Cloud White  
**panel glazing:** TR Clear, FR Frosted (XLT option)  
**laminate (side 1):** see page 6  
**laminate (side 2):** see page 6

### ORDER EXAMPLE

**product #:** FHPGHSPA.3924E  
**finish:** DT  
**panel glazing:** FR Frosted  
**laminate (side 1):** FB2960 Mochatini  
**laminate (side 2):** FB3400 Aria

### 53" HIGH

PART #	HEIGHT	WIDTH	DEPTH	WT. (LBS)	LIST
FHPGHSPA.5324E	53"	24"	2"	33	\$1,111
FHPGHSPA.5330E	53"	30"	2"	40	\$1,260
FHPGHSPA.5336E	53"	36"	2"	43	\$1,404
FHPGHSPA.5342E	53"	42"	2"	47	\$1,506
FHPGHSPA.5348E	53"	48"	2"	53	\$1,556

### NOTES

- For matching worksurface to hardsurface panel, see page 6

### 67" HIGH

PART #	HEIGHT	WIDTH	DEPTH	WT. (LBS)	LIST
FHPGHSPA.6724E	67"	24"	2"	41	\$1,333
FHPGHSPA.6730E	67"	30"	2"	47	\$1,502
FHPGHSPA.6736E	67"	36"	2"	53	\$1,684
FHPGHSPA.6742E	67"	42"	2"	59	\$1,836
FHPGHSPA.6748E	67"	48"	2"	67	\$1,891

### NOTES

- For matching worksurface to hardsurface panel, see page 6

### 85" HIGH

PART #	HEIGHT	WIDTH	DEPTH	WT. (LBS)	LIST
FHPGHSPA.8524E	85"	24"	2"	50	\$1,565
FHPGHSPA.8530E	85"	30"	2"	59	\$1,818
FHPGHSPA.8536E	85"	36"	2"	67	\$2,054
FHPGHSPA.8542E	85"	42"	2"	75	\$2,236
FHPGHSPA.8548E	85"	48"	2"	84	\$2,309

### NOTES

- For matching worksurface to hardsurface panel, see page 6

## Monolithic Fabric-Covered Panel Non-Electrical

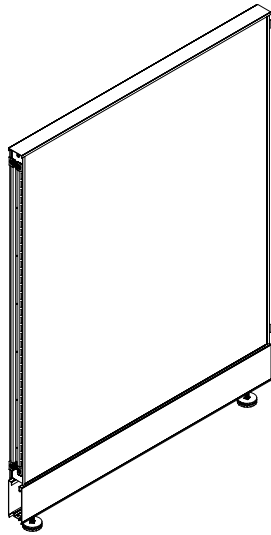

### DESCRIPTION

Structural panel with fabric surfaces, painted top caps and trim, leveling glides, and cable management side covers.

### NOTES

- Order connectors and finished ends separately

### SPECIFICATION OPTIONS

**product #:** see charts below  
**finish:** DT Dark Tone, MT Medium Tone, CW Cloud White  
**fabric (side 1):** see page 4  
**fabric (side 2):** see page 4

### ORDER EXAMPLE

**product #:** FHFAPA.3924N  
**finish:** DT  
**fabric (side 1):** Silky/Natural PF401-1  
**fabric (side 2):** Silky/Natural PF401-1

### 39" HIGH

PART #	HEIGHT	WIDTH	DEPTH	WT. (LBS)	LIST
FHFAPA.3924N	39"	24"	2"	26	\$343
FHFAPA.3930N	39"	30"	2"	27	\$372
FHFAPA.3936N	39"	36"	2"	31	\$417
FHFAPA.3942N	39"	42"	2"	36	\$438
FHFAPA.3948N	39"	48"	2"	39	\$458

### NOTES

### 47" HIGH

PART #	HEIGHT	WIDTH	DEPTH	WT. (LBS)	LIST
FHFAPA.4724N	47"	24"	2"	29	\$360
FHFAPA.4730N	47"	30"	2"	33	\$400
FHFAPA.4736N	47"	36"	2"	38	\$454
FHFAPA.4742N	47"	42"	2"	41	\$499
FHFAPA.4748N	47"	48"	2"	47	\$514

### NOTES

### 53" HIGH

PART #	HEIGHT	WIDTH	DEPTH	WT. (LBS)	LIST
FHFAPA.5324N	53"	24"	2"	32	\$368
FHFAPA.5330N	53"	30"	2"	38	\$414
FHFAPA.5336N	53"	36"	2"	41	\$480
FHFAPA.5342N	53"	42"	2"	44	\$516
FHFAPA.5348N	53"	48"	2"	51	\$548

### NOTES

**67" HIGH**

PART #	HEIGHT	WIDTH	DEPTH	WT. (LBS)	LIST
FHFAPA.6724N	67"	24"	2"	40	\$423
FHFAPA.6730N	67"	30"	2"	46	\$472
FHFAPA.6736N	67"	36"	2"	51	\$542
FHFAPA.6742N	67"	42"	2"	57	\$576
FHFAPA.6748N	67"	48"	2"	64	\$612

NOTES

**85" HIGH**

PART #	HEIGHT	WIDTH	DEPTH	WT. (LBS)	LIST
FHFAPA.8524N	85"	24"	2"	50	\$495
FHFAPA.8530N	85"	30"	2"	58	\$547
FHFAPA.8536N	85"	36"	2"	65	\$629
FHFAPA.8542N	85"	42"	2"	73	\$667
FHFAPA.8548N	85"	48"	2"	81	\$707

NOTES

Standard fabric application for panels 67" and below is horizontal application. Panels taller than 67" are only available in vertical application. When ordering panels 67" and below to match a panel taller than 67", specify vertical application.

## Monolithic Fabric-Covered Panel Electrical

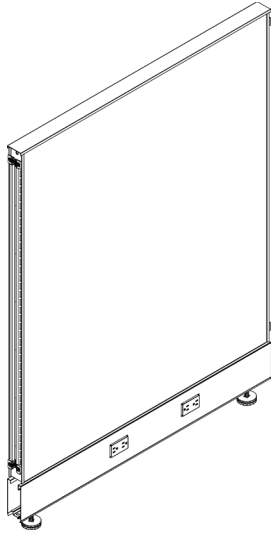

### DESCRIPTION

Structural panel with fabric surfaces, painted top caps and trim, leveling glides, 4-circuit power installed in cable management raceway covers.

### NOTES

- 24" wide panels have one receptacle per side
- 30" to 48" wide panels have two receptacle locations per side
- Order receptacles separately
- Includes panel to panel festoon
- Order panel through post festoon separately
- Order connectors and finished ends separately

### SPECIFICATION OPTIONS

**product #:** see charts below  
**finish:** DT Dark Tone, MT Medium Tone, CW Cloud White  
**fabric (side 1):** see page 4  
**fabric (side 2):** see page 4

### ORDER EXAMPLE

**product #:** FHFAPA.3924E  
**finish:** DT  
**fabric (side 1):** Silky/Natural PF401-1  
**fabric (side 2):** Silky/Natural PF401-1

### 39" HIGH

PART #	HEIGHT	WIDTH	DEPTH	WT. (LBS)	LIST	NOTES
FHFAPA.3924E	39"	24"	2"	27	\$469	
FHFAPA.3930E	39"	30"	2"	29	\$498	
FHFAPA.3936E	39"	36"	2"	33	\$543	
FHFAPA.3942E	39"	42"	2"	38	\$565	
FHFAPA.3948E	39"	48"	2"	42	\$585	

### 47" HIGH

PART #	HEIGHT	WIDTH	DEPTH	WT. (LBS)	LIST	NOTES
FHFAPA.4724E	47"	24"	2"	30	\$488	
FHFAPA.4730E	47"	30"	2"	35	\$527	
FHFAPA.4736E	47"	36"	2"	40	\$580	
FHFAPA.4742E	47"	42"	2"	43	\$627	
FHFAPA.4748E	47"	48"	2"	50	\$641	

### 53" HIGH

PART #	HEIGHT	WIDTH	DEPTH	WT. (LBS)	LIST	NOTES
FHFAPA.5324E	53"	24"	2"	33	\$494	
FHFAPA.5330E	53"	30"	2"	40	\$541	
FHFAPA.5336E	53"	36"	2"	43	\$607	
FHFAPA.5342E	53"	42"	2"	47	\$643	
FHFAPA.5348E	53"	48"	2"	53	\$676	

**67" HIGH**

PART #	HEIGHT	WIDTH	DEPTH	WT. (LBS)	LIST
FHFAPA.6724E	67"	24"	2"	41	\$550
FHFAPA.6730E	67"	30"	2"	47	\$599
FHFAPA.6736E	67"	36"	2"	53	\$669
FHFAPA.6742E	67"	42"	2"	59	\$703
FHFAPA.6748E	67"	48"	2"	67	\$739

**NOTES**

- For matching worksurface to hardsurface panel, see page 6

**85" HIGH**

PART #	HEIGHT	WIDTH	DEPTH	WT. (LBS)	LIST
FHFAPA.8524E	85"	24"	2"	50	\$623
FHFAPA.8530E	85"	30"	2"	59	\$675
FHFAPA.8536E	85"	36"	2"	67	\$755
FHFAPA.8542E	85"	42"	2"	75	\$793
FHFAPA.8548E	85"	48"	2"	84	\$834

**NOTES**

Standard fabric application for panels 67" and below is horizontal application. Panels taller than 67" are only available in vertical application. When ordering panels 67" and below to match a panel taller than 67", specify vertical application.

## Monolithic Partial Glazed Panel Non-Electrical

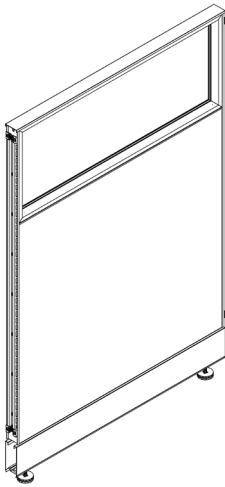

### DESCRIPTION

Structural panel with fabric covered lower surfaces and 14" high tempered glass top section, painted top cap and cable management side covers.

### NOTES

- Order connectors and finished ends separately.
- Cannot be used as dry erase surface.

### SPECIFICATION OPTIONS

**product #:** see charts below

**finish:** DT Dark Tone, MT Medium Tone, CW Cloud White

**panel glazing:** TR Clear, FR Frosted (XLT option)

**fabric (side 1):** see page 4

**fabric (side 2):** see page 4

### ORDER EXAMPLE

**product #:** FHPGPA.5324N

**finish:** DT

**panel glazing:** TR Clear

**fabric (side 1):** Silky/Natural PF401-1

**fabric (side 2):** Silky/Natural PF401-1

### 53" HIGH

PART #	HEIGHT	WIDTH	DEPTH	WT. (LBS)	LIST
FHPGPA.5324N	53"	24"	2"	37	\$548
FHPGPA.5330N	53"	30"	2"	41	\$595
FHPGPA.5336N	53"	36"	2"	47	\$713
FHPGPA.5342N	53"	42"	2"	54	\$749
FHPGPA.5348N	53"	48"	2"	61	\$817

### NOTES

### 67" HIGH

PART #	HEIGHT	WIDTH	DEPTH	WT. (LBS)	LIST
FHPGPA.6724N	67"	24"	2"	42	\$603
FHPGPA.6730N	67"	30"	2"	50	\$652
FHPGPA.6736N	67"	36"	2"	56	\$772
FHPGPA.6742N	67"	42"	2"	62	\$808
FHPGPA.6748N	67"	48"	2"	71	\$881

### NOTES

### 85" HIGH

PART #	HEIGHT	WIDTH	DEPTH	WT. (LBS)	LIST
FHPGPA.8524N	85"	24"	2"	49	\$676
FHPGPA.8530N	85"	30"	2"	57	\$728
FHPGPA.8536N	85"	36"	2"	65	\$861
FHPGPA.8542N	85"	42"	2"	73	\$899
FHPGPA.8548N	85"	48"	2"	83	\$975

### NOTES

## Monolithic Partial Glazed Panel Electrical

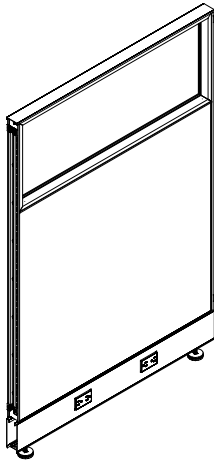

### DESCRIPTION

Structural panel with fabric covered lower surfaces and 14" high tempered glass top section, painted top cap and leveling glides, 4-circuit power installed in cable management raceway covers.

### NOTES

- 24" wide panels have one receptacle per side.
- 30" to 48" wide panels have two receptacle locations per side.
- Includes panel to panel festoon.
- Order connectors and finished ends separately.
- Order panel through post festoon separately.
- Cannot be used as dry erase surface

### SPECIFICATION OPTIONS

**product #:** see charts below  
**finish:** DT Dark Tone, MT Medium Tone, CW Cloud White  
**panel glazing:** TR Clear, FR Frosted (XLT option)  
**fabric (side 1):** see page 6  
**fabric (side 2):** see page 6

### ORDER EXAMPLE

**product #:** FHPGPA.5324E  
**finish:** DT  
**panel glazing:** TR Clear  
**fabric (side 1):** Silky/Natural PF401-1  
**fabric (side 2):** Silky/Natural PF401-1

### 53" HIGH

PART #	HEIGHT	WIDTH	DEPTH	WT. (LBS)	LIST
FHPGPA.5324E	53"	24"	2"	38	\$676
FHPGPA.5330E	53"	30"	2"	42	\$721
FHPGPA.5336E	53"	36"	2"	49	\$839
FHPGPA.5342E	53"	42"	2"	56	\$875
FHPGPA.5348E	53"	48"	2"	63	\$943

### NOTES

### 67" HIGH

PART #	HEIGHT	WIDTH	DEPTH	WT. (LBS)	LIST
FHPGPA.6724E	67"	24"	2"	43	\$731
FHPGPA.6730E	67"	30"	2"	52	\$780
FHPGPA.6736E	67"	36"	2"	57	\$901
FHPGPA.6742E	67"	42"	2"	64	\$935
FHPGPA.6748E	67"	48"	2"	74	\$1,008

### NOTES

### 85" HIGH

PART #	HEIGHT	WIDTH	DEPTH	WT. (LBS)	LIST
FHPGPA.8524E	85"	24"	2"	50	\$803
FHPGPA.8530E	85"	30"	2"	58	\$855
FHPGPA.8536E	85"	36"	2"	67	\$988
FHPGPA.8542E	85"	42"	2"	75	\$1,026
FHPGPA.8548E	85"	48"	2"	85	\$1,102

### NOTES





# SEGMENTED PANELS

## Specification Guide: Design 1 & 2 Segmented Panel Kit

Both Design 1 and Design 2 panels require a **segmented panel kit**, the structure on which segments are added. Available electrical or non-electrical in these heights: 39", 47", 53", 67" and 85".

### NON-ELECTRICAL

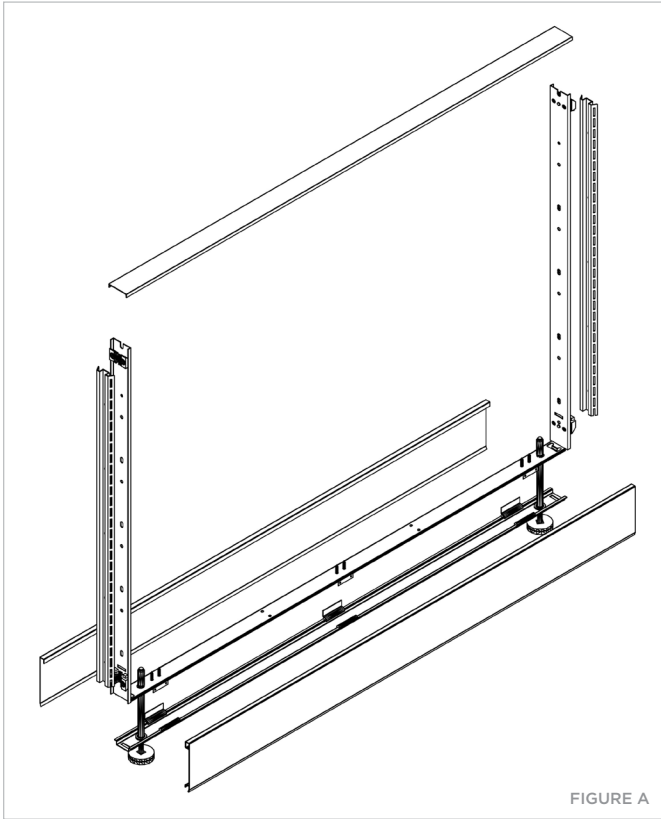

FIGURE A

### ELECTRICAL

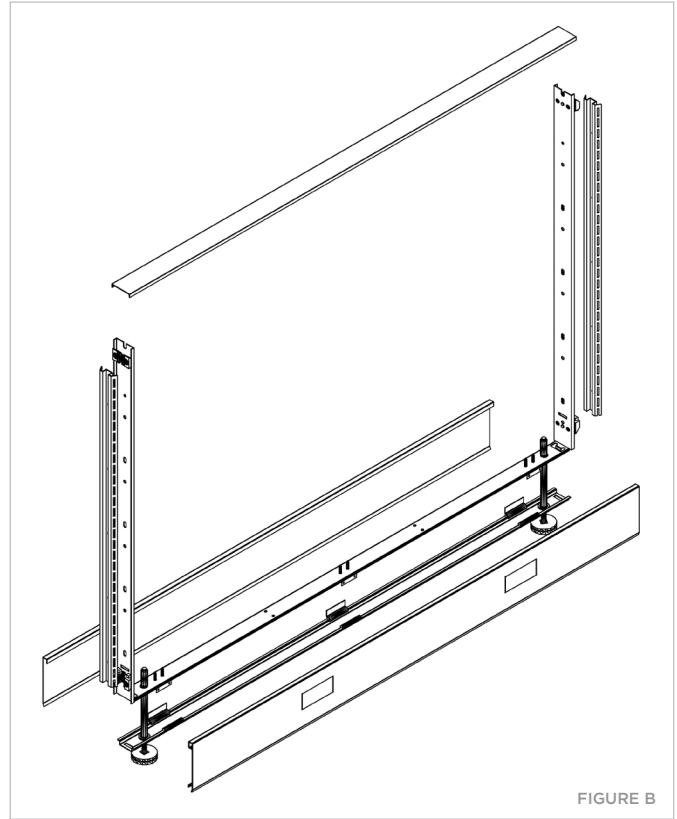

FIGURE B

### NON-ELECTRICAL KIT INCLUDES

- Top cap
- Base kit
- Base covers
- Side rails
- Hanger rails

### ELECTRICAL KIT INCLUDES

- Top cap
- Base kit
- Base covers
- Side rails
- Hanger rails
- Power retro
- Panel-to-panel festoon

### NOTES

Panel through post festoon and 90° angle festoon must be ordered separately.

24" wide panel kits have one duplex cutout per side.  
30" to 48" panel kits have two duplex cutouts per side.

## Specification Guide: Design 1 & 2 Segments

Both Design 1 and Design 2 panels require a **base segment**, at the bottom of the panel kit, and **additional segments** to complete the panel. All segments finish both sides of the panel.

### BASE SEGMENTS

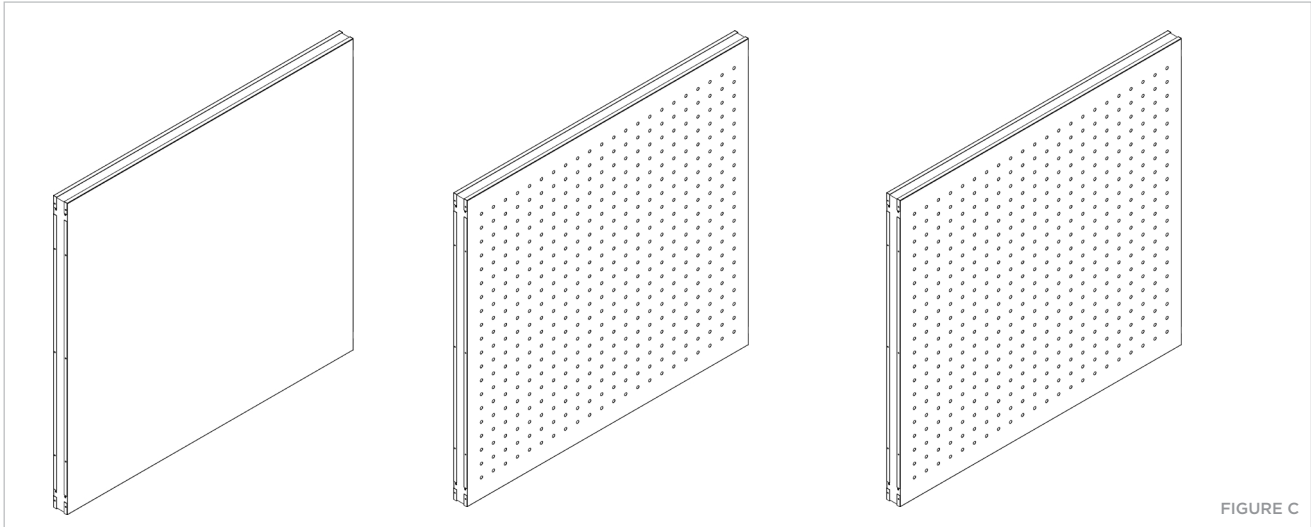

FIGURE C

#### Fabric/Fabric

Fabric on both sides.  
Available for Design 1 or 2.

#### Perforated Metal/Fabric

Painted perforated metal on one side and fabric on other side.  
Available for Design 1 only.

#### Perforated Metal/Perforated Metal

Painted perforated metal on both sides.  
Available for Design 1 only.

### ADDITIONAL SEGMENTS

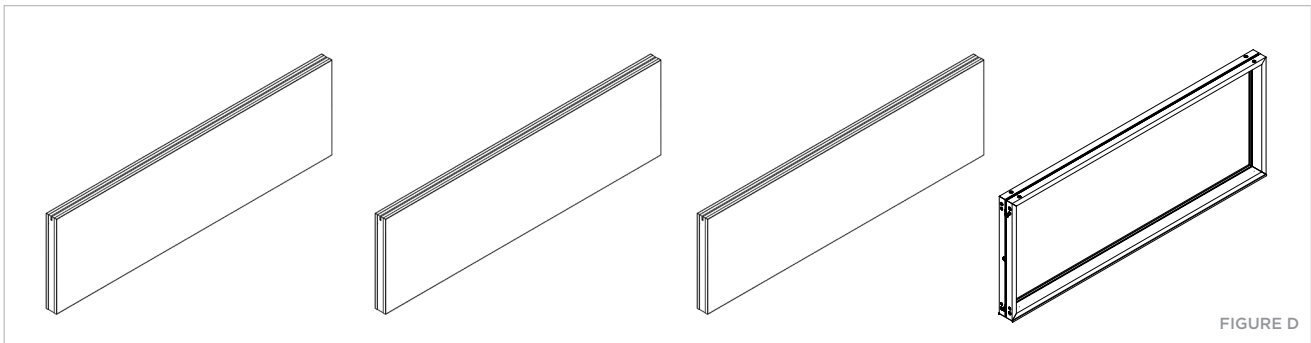

FIGURE D

#### Fabric/Fabric

Fabric on both sides.  
Available for Design 1 or 2.

#### Markerboard/Fabric

Markerboard on one side, and fabric on other side.  
Available for Design 1 or 2.

#### Markerboard/Markerboard

Markerboard both sides.  
Available for Design 1 or 2.

#### Glazed

Glass both sides, available clear or frosted.  
Available for Design 1 or 2.

## Specification Guide: Design 1 Segmented Panels

Design 1 panels have **26”H base segments**, allowing for an additional segment per panel compared to Design 2.

### DESIGN 1 ELEVATIONS

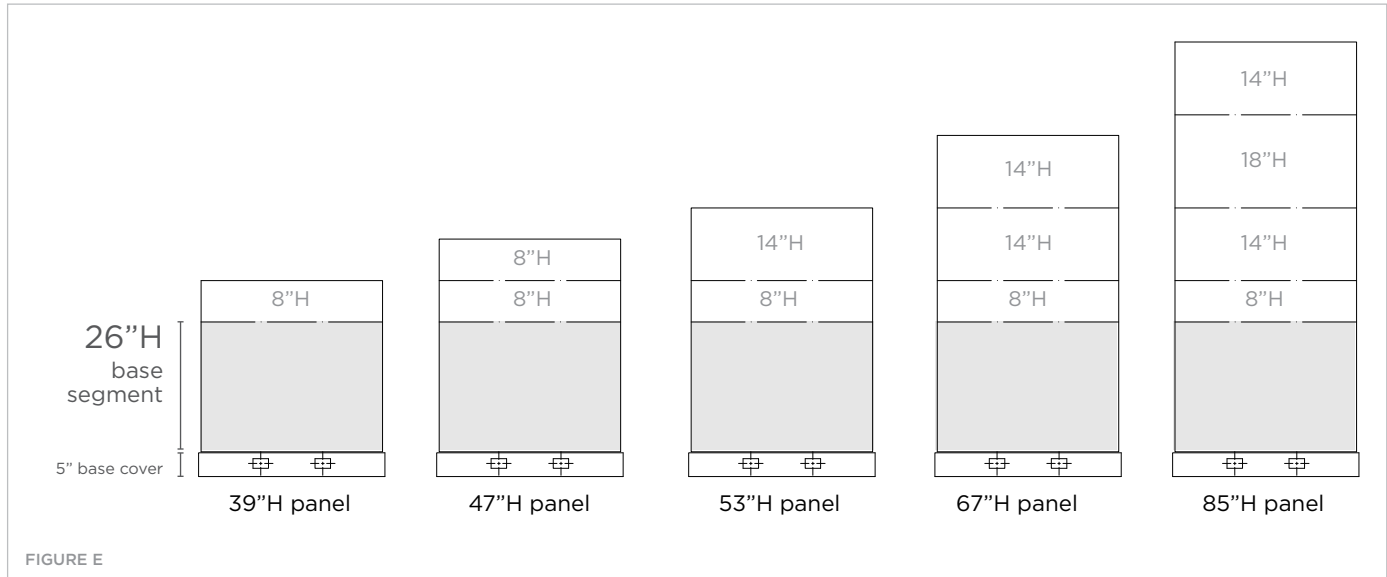

### DESIGN 1 BASE SEGMENT FINISH OPTIONS

Base segments for Design 1 panels are 26”H fabric/fabric, perforated metal/fabric or perforated metal/perforated metal.

#### 26” high base segments

- fabric/fabric
- perforated metal/fabric
- perforated metal/perforated metal

### DESIGN 1 ADDITIONAL SEGMENTS

Please refer to the diagram above (Figure E) for segment size combinations per panel height. Additional segments are available in the finishes and sizes below:

8” high	14” high	18” high
fabric/fabric	fabric/fabric	fabric/fabric
	markerboard/fabric	
	markerboard/markerboard	
	glazed	

### HOW TO SPECIFY A DESIGN 1 PANEL

- 1 Order a Design 1 Segmented Panel Kit.**  
Choose an electrical or non-electrical kit, then choose the panel size.  
  
**Note:** All segments finish both sides of the panel. Specify the finish for each side.
- 2 Order a Design 1 Base Segment.**  
Choose fabric/fabric, perforated metal/fabric, or perforated metal/perforated metal.
- 3 Order additional segments.**  
Choose segments to complete the panel at the correct size per the diagram above (Figure E).

**Specification Guide:** Design 2 Segmented Panels

Design 2 panels have **34”H base segments**, with one less additional segment per panel compared to Design 1.

**DESIGN 2 ELEVATIONS**

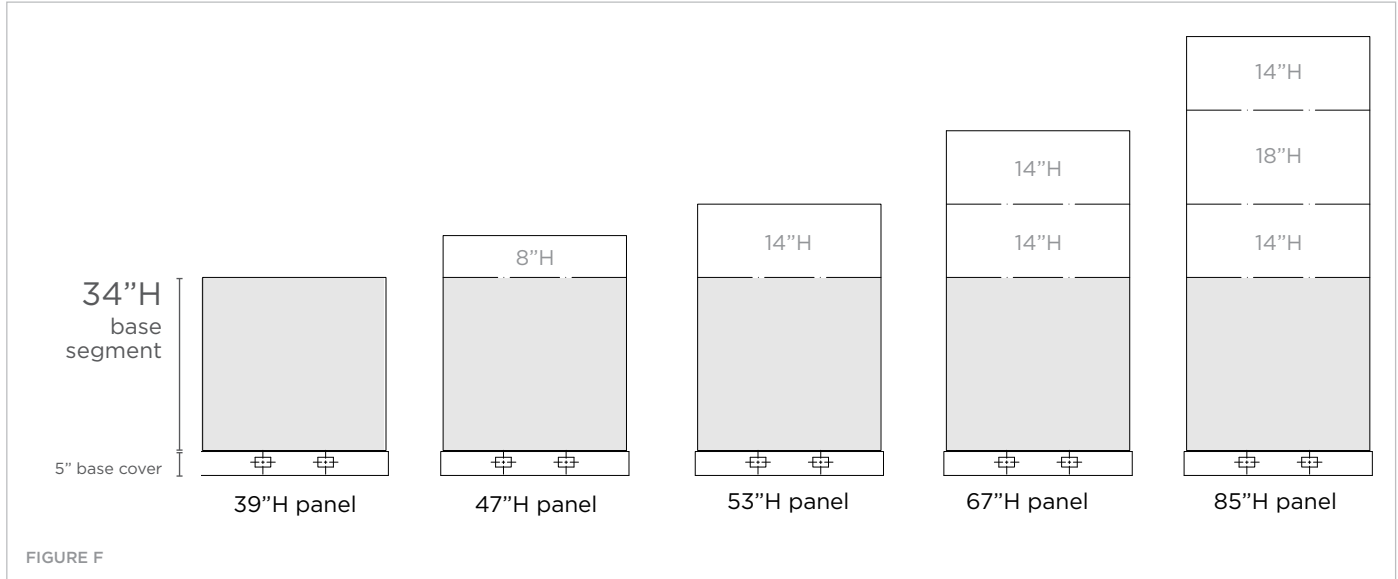

**DESIGN 2 BASE SEGMENT FINISH OPTION**

Base segments for Design 2 panels are 34”H fabric covered.

**34” high base segments**  
fabric/fabric

**DESIGN 2 ADDITIONAL SEGMENTS**

Please refer to the diagram above (Figure F) for segment size combinations per panel height. Additional segments are available in the finishes and sizes below:

8” high	14” high	18” high
fabric/fabric	fabric/fabric	fabric/fabric
	markerboard/fabric	
	markerboard/markerboard	
	glazed	

**HOW TO SPECIFY A DESIGN 2 PANEL**

- Order a Design 2 Segmented Panel Kit.** Choose an electrical or non-electrical kit, then choose the panel size.  
*Note:* All segments finish both sides of the panel. Specify the finish for each side.
- Order a Design 2 Base Segment.** All Design 2 base segments are fabric/fabric.
- Order additional segments.** Choose segments to complete the panel at the correct size per the diagram above (Figure F).

## Design 1 Segmented Panel

### How to Order & Specify

- 1 Select a panel kit size.** Electrical or Non-Electrical, both with metal base cover.
- 2 Select a base segment.** Add price of one base segment to panel kit price.
- 3 Select additional segments.** Complete the panel with segments (reference diagram on page 9). Add prices to the total.  
  
NOTE: All segments finish both sides of the panel. Specify the finish for each side.
- 4 Calculate total.** Add prices of all selections for total cost of panel.
- 5 Specify finishes.** Select fabrics and finishes as appropriate; reference opposite page.

### Order Example

- 1 Select a panel kit size.**  
67"H x 24"W non-electrical panel kit for \$184.
- 2 Select a base segment.**  
26"H fabric covered base segment for \$100.
- 3 Select additional segments.**  
8"H fabric/fabric segment for \$62  
14"H markerboard/fabric segment for \$175  
14"H glazed segment for \$274
- 4 Calculate total.**  
panel kit (\$213 kit)  
+ \$100 base segment  
+ additional segments (\$62 + \$175 + \$274)  
= \$824 total
- 5 Specify finishes.**  
base segment: side 1 PF601-1, side 2 PF601-1  
8"H fabric/fabric: side 1 PF601-5, side 2 PF601-6  
14"H markerboard/fabric: side 1 markerboard, side 2 PF601-1  
14"H glazed: side 1 TR clear, side 2 TR clear

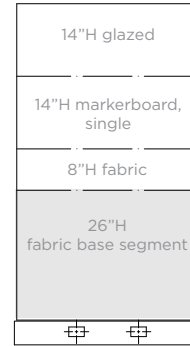

67"H x 24"W non-electrical panel kit with metal base cover

## NON-ELECTRICAL

(1) PANEL KIT Specify size of panel frame				(2) BASE SEGMENT Specify one base segment			(3) ADDITIONAL SEGMENT Specify as many segments as needed to complete panel						
HEIGHT	WIDTH	MODEL #	LIST	26"H FABRIC, FABRIC	26"H PERF. METAL, FABRIC	26"H PERF. METAL, PERF. METAL	8"H FABRIC, FABRIC	14"H FABRIC, FABRIC	14"H MARKER, FABRIC	14"H MARKER, MARKER	14"H GLAZED	18"H FABRIC, FABRIC	
39"	24"	FHPK.3924N-D1	\$172	+\$100	+\$133	+\$168	+\$62	X	X	X	X	X	
	30"	FHPK.3930N-D1	\$187	+\$119	+\$161	+\$206	+\$71	X	X	X	X	X	
	36"	FHPK.3936N-D1	\$199	+\$161	+\$181	+\$245	+\$73	X	X	X	X	X	
	42"	FHPK.3942N-D1	\$216	+\$178	+\$209	+\$281	+\$81	X	X	X	X	X	
	48"	FHPK.3948N-D1	\$229	+\$178	+\$242	+\$317	+\$93	X	X	X	X	X	
47"	24"	FHPK.4724N-D1	\$183	+\$100	+\$133	+\$168	+\$62	X	X	X	X	X	
	30"	FHPK.4730N-D1	\$198	+\$119	+\$161	+\$206	+\$71	X	X	X	X	X	
	36"	FHPK.4736N-D1	\$211	+\$161	+\$181	+\$245	+\$73	X	X	X	X	X	
	42"	FHPK.4742N-D1	\$227	+\$178	+\$209	+\$281	+\$81	X	X	X	X	X	
	48"	FHPK.4748N-D1	\$240	+\$178	+\$242	+\$317	+\$93	X	X	X	X	X	
53"	24"	FHPK.5324N-D1	\$193	+\$100	+\$133	+\$168	+\$62	+\$75	+\$175	+\$153	+\$274	X	
	30"	FHPK.5330N-D1	\$209	+\$119	+\$161	+\$206	+\$71	+\$81	+\$202	+\$176	+\$322	X	
	36"	FHPK.5336N-D1	\$221	+\$161	+\$181	+\$245	+\$73	+\$92	+\$240	+\$210	+\$371	X	
	42"	FHPK.5342N-D1	\$238	+\$178	+\$209	+\$281	+\$81	+\$106	+\$253	+\$219	+\$420	X	
	48"	FHPK.5348N-D1	\$250	+\$178	+\$242	+\$317	+\$93	+\$117	+\$284	+\$246	+\$468	X	
67"	24"	FHPK.6724N-D1	\$213	+\$100	+\$133	+\$168	+\$62	+\$75	+\$175	+\$153	+\$274	X	
	30"	FHPK.6730N-D1	\$228	+\$119	+\$161	+\$206	+\$71	+\$81	+\$202	+\$176	+\$322	X	
	36"	FHPK.6736N-D1	\$240	+\$161	+\$181	+\$245	+\$73	+\$92	+\$240	+\$210	+\$371	X	
	42"	FHPK.6742N-D1	\$257	+\$178	+\$209	+\$281	+\$81	+\$106	+\$253	+\$219	+\$420	X	
	48"	FHPK.6748N-D1	\$270	+\$178	+\$242	+\$317	+\$93	+\$117	+\$284	+\$246	+\$468	X	
85"	24"	FHPK.8524N-D1	\$241	+\$100	+\$133	+\$168	+\$62	+\$75	+\$175	+\$153	+\$274	+\$83	
	30"	FHPK.8530N-D1	\$257	+\$119	+\$161	+\$206	+\$71	+\$81	+\$202	+\$176	+\$322	+\$91	
	36"	FHPK.8536N-D1	\$269	+\$161	+\$181	+\$245	+\$73	+\$92	+\$240	+\$210	+\$371	+\$127	
	42"	FHPK.8542N-D1	\$286	+\$178	+\$209	+\$281	+\$81	+\$106	+\$253	+\$219	+\$420	+\$136	
	48"	FHPK.8548N-D1	\$298	+\$178	+\$242	+\$317	+\$93	+\$117	+\$284	+\$246	+\$468	+\$141	

Fabric/Finish Specifications		Specifications Example: Design 1	
<b>BASE SEGMENTS</b>	<b>ADDITIONAL SEGMENTS</b>		
<b>Fabric/Fabric</b> fabric (side 1): see page 4 fabric (side 2): see page 4	<b>Fabric/Fabric</b> fabric (side 1): see page 4 fabric (side 2): see page 4	glass: clear	glass: clear
<b>Perforated Metal/Fabric</b> paint (side 1 or 2): DT, MT, or CW fabric (side 1 or 2): see page 4	<b>Markerboard/Markerboard</b> no specifications	markerboard: n/a	fabric: PF601-1
<b>Perforated Metal/ Perforated Metal</b> paint (side 1): DT, MT, or CW paint (side 2): DT, MT, or CW	<b>Markerboard/Fabric</b> markerboard (side 1 or 2): n/a fabric (side 1 or 2): see page 4	fabric: PF601-5	fabric: PF601-6
	<b>Glazed</b> glass (side 1): TR Clear or FR Frosted (XLT option) glass (side 2): TR Clear or FR Frosted (XLT option)	fabric: PF601-1	fabric: PF601-1
		SIDE 1	SIDE 2

**ELECTRICAL**

(1) PANEL KIT Specify size of panel frame				(2) BASE SEGMENT Specify one base segment			(3) ADDITIONAL SEGMENT Specify as many segments as needed to complete panel					
HEIGHT	WIDTH	MODEL #	LIST	26"H FABRIC, FABRIC	26"H PERF. METAL, FABRIC	26"H PERF. METAL, PERF. METAL	8"H FABRIC, FABRIC	14"H FABRIC, FABRIC	14"H MARKER, FABRIC	14"H MARKER, MARKER	14"H GLAZED	18"H FABRIC, FABRIC
39"	24"	FHPK.3924E-D1	\$318	+ \$100	+ \$133	+ \$168	+ \$62	X	X	X	X	X
	30"	FHPK.3930E-D1	\$359	+ \$119	+ \$161	+ \$206	+ \$71	X	X	X	X	X
	36"	FHPK.3936E-D1	\$388	+ \$161	+ \$181	+ \$245	+ \$73	X	X	X	X	X
	42"	FHPK.3942E-D1	\$428	+ \$178	+ \$209	+ \$281	+ \$81	X	X	X	X	X
	48"	FHPK.3948E-D1	\$463	+ \$178	+ \$242	+ \$317	+ \$93	X	X	X	X	X
47"	24"	FHPK.4724E-D1	\$330	+ \$100	+ \$133	+ \$168	+ \$62	X	X	X	X	X
	30"	FHPK.4730E-D1	\$370	+ \$119	+ \$161	+ \$206	+ \$71	X	X	X	X	X
	36"	FHPK.4736E-D1	\$400	+ \$161	+ \$181	+ \$245	+ \$73	X	X	X	X	X
	42"	FHPK.4742E-D1	\$439	+ \$178	+ \$209	+ \$281	+ \$81	X	X	X	X	X
	48"	FHPK.4748E-D1	\$474	+ \$178	+ \$242	+ \$317	+ \$93	X	X	X	X	X
53"	24"	FHPK.5324E-D1	\$341	+ \$100	+ \$133	+ \$168	+ \$62	+ \$75	+ \$175	+ \$153	+ \$274	X
	30"	FHPK.5330E-D1	\$381	+ \$119	+ \$161	+ \$206	+ \$71	+ \$81	+ \$202	+ \$176	+ \$322	X
	36"	FHPK.5336E-D1	\$411	+ \$161	+ \$181	+ \$245	+ \$73	+ \$92	+ \$240	+ \$210	+ \$371	X
	42"	FHPK.5342E-D1	\$450	+ \$178	+ \$209	+ \$281	+ \$81	+ \$106	+ \$253	+ \$219	+ \$420	X
	48"	FHPK.5348E-D1	\$485	+ \$178	+ \$242	+ \$317	+ \$93	+ \$117	+ \$284	+ \$246	+ \$468	X
67"	24"	FHPK.6724E-D1	\$361	+ \$100	+ \$133	+ \$168	+ \$62	+ \$75	+ \$175	+ \$153	+ \$274	X
	30"	FHPK.6730E-D1	\$401	+ \$119	+ \$161	+ \$206	+ \$71	+ \$81	+ \$202	+ \$176	+ \$322	X
	36"	FHPK.6736E-D1	\$430	+ \$161	+ \$181	+ \$245	+ \$73	+ \$92	+ \$240	+ \$210	+ \$371	X
	42"	FHPK.6742E-D1	\$470	+ \$178	+ \$209	+ \$281	+ \$81	+ \$106	+ \$253	+ \$219	+ \$420	X
	48"	FHPK.6748E-D1	\$505	+ \$178	+ \$242	+ \$317	+ \$93	+ \$117	+ \$284	+ \$246	+ \$468	X
85"	24"	FHPK.8524E-D1	\$381	+ \$100	+ \$133	+ \$168	+ \$62	+ \$75	+ \$175	+ \$153	+ \$274	+ \$83
	30"	FHPK.8530E-D1	\$421	+ \$119	+ \$161	+ \$206	+ \$71	+ \$81	+ \$202	+ \$176	+ \$322	+ \$91
	36"	FHPK.8536E-D1	\$450	+ \$161	+ \$181	+ \$245	+ \$73	+ \$92	+ \$240	+ \$210	+ \$371	+ \$127
	42"	FHPK.8542E-D1	\$488	+ \$178	+ \$209	+ \$281	+ \$81	+ \$106	+ \$253	+ \$219	+ \$420	+ \$136
	48"	FHPK.8548E-D1	\$523	+ \$178	+ \$242	+ \$317	+ \$93	+ \$117	+ \$284	+ \$246	+ \$468	+ \$141

## Design 2 Segmented Panel

### How to Order & Specify

- 1 Select a panel kit size.** Electrical or Non-Electrical, both with metal base cover.
- 2 Add a base segment.** Add price of the base segment to panel kit price.
- 3 Select additional segments.** Complete the panel with segments (reference diagram on page 9). Add prices to the total.  
  
NOTE: All segments finish both sides of the panel. Specify the finish for each side.
- 4 Calculate total.** Add prices of all selections for total cost of panel.
- 5 Specify finishes.** Select fabrics and finishes as appropriate; reference opposite page.

### Order Example

- 1 Select a panel kit size.**  
67"H x 24"W non-electrical panel kit for \$184.
- 2 Add a base segment.**  
34"H fabric covered base segment for \$159.
- 3 Select additional segments.**  
14"H markerboard/fabric segment for \$175  
14"H glazed segment for \$274
- 4 Calculate total.**  
panel kit (\$213 kit)  
+ \$159 base segment  
+ additional segments (\$175 + \$274)  
= \$821 total
- 5 Specify finishes.**  
base segment: side 1 PF601-1, side 2 PF601-1  
14"H markerboard/fabric: side 1 markerboard, side 2 PF601-1  
14"H glazed: side 1 TR clear, side 2 TR clear

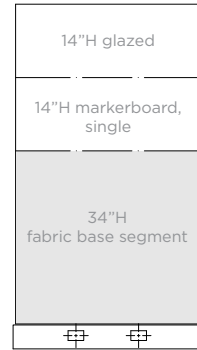

67"H x 24"W non-electrical panel kit with metal base cover

## NON-ELECTRICAL

(1) PANEL KIT Specify size of panel frame				(2) BASE SEGMENT Add base segment	(3) ADDITIONAL SEGMENT Specify as many segments as needed to complete panel					
HEIGHT	WIDTH	MODEL #	LIST	34"H FABRIC, FABRIC	8"H FABRIC, FABRIC	14"H FABRIC, FABRIC	14"H MARKER, FABRIC	14"H MARKER, MARKER	14"H GLAZED	18"H FABRIC, FABRIC
39"	24"	FHPK.3924N-D2	\$172	+ \$159	X	X	X	X	X	X
	30"	FHPK.3930N-D2	\$187	+ \$187	X	X	X	X	X	X
	36"	FHPK.3936N-D2	\$199	+ \$229	X	X	X	X	X	X
	42"	FHPK.3942N-D2	\$216	+ \$252	X	X	X	X	X	X
	48"	FHPK.3948N-D2	\$229	+ \$267	X	X	X	X	X	X
47"	24"	FHPK.4724N-D2	\$172	+ \$159	+ \$62	X	X	X	X	X
	30"	FHPK.4730N-D2	\$198	+ \$187	+ \$71	X	X	X	X	X
	36"	FHPK.4736N-D2	\$211	+ \$229	+ \$73	X	X	X	X	X
	42"	FHPK.4742N-D2	\$227	+ \$252	+ \$81	X	X	X	X	X
	48"	FHPK.4748N-D2	\$240	+ \$267	+ \$93	X	X	X	X	X
53"	24"	FHPK.5324N-D2	\$193	+ \$159	X	+ \$75	+ \$175	+ \$153	+ \$274	X
	30"	FHPK.5330N-D2	\$209	+ \$187	X	+ \$81	+ \$202	+ \$176	+ \$322	X
	36"	FHPK.5336N-D2	\$221	+ \$229	X	+ \$92	+ \$240	+ \$210	+ \$371	X
	42"	FHPK.5342N-D2	\$238	+ \$252	X	+ \$106	+ \$253	+ \$219	+ \$420	X
	48"	FHPK.5348N-D2	\$250	+ \$267	X	+ \$117	+ \$284	+ \$246	+ \$468	X
67"	24"	FHPK.6724N-D2	\$213	+ \$159	X	+ \$75	+ \$175	+ \$153	+ \$274	X
	30"	FHPK.6730N-D2	\$228	+ \$187	X	+ \$81	+ \$202	+ \$176	+ \$322	X
	36"	FHPK.6736N-D2	\$240	+ \$229	X	+ \$92	+ \$240	+ \$210	+ \$371	X
	42"	FHPK.6742N-D2	\$257	+ \$252	X	+ \$106	+ \$253	+ \$219	+ \$420	X
	48"	FHPK.6748N-D2	\$270	+ \$267	X	+ \$117	+ \$284	+ \$246	+ \$468	X
85"	24"	FHPK.8524N-D2	\$241	+ \$159	X	+ \$75	+ \$175	+ \$153	+ \$274	+ \$83
	30"	FHPK.8530N-D2	\$257	+ \$187	X	+ \$81	+ \$202	+ \$176	+ \$322	+ \$91
	36"	FHPK.8536N-D2	\$269	+ \$229	X	+ \$92	+ \$240	+ \$210	+ \$371	+ \$127
	42"	FHPK.8542N-D2	\$286	+ \$252	X	+ \$106	+ \$253	+ \$219	+ \$420	+ \$136
	48"	FHPK.8548N-D2	\$298	+ \$267	X	+ \$117	+ \$284	+ \$246	+ \$468	+ \$141



Fabric/Finish Specifications		Specifications Example: Design 2	
<b>BASE SEGMENT</b>	<b>ADDITIONAL SEGMENTS</b>		
<b>Fabric/Fabric</b> fabric (side 1): see page 4 fabric (side 2): see page 4	<b>Fabric/Fabric</b> fabric (side 1): see page 4 fabric (side 2): see page 4		
	<b>Markerboard/Markerboard</b> no specifications		
	<b>Markerboard/Fabric</b> markerboard (side 1 or 2): n/a fabric (side 1 or 2): page 4		
	<b>Glazed</b> glass (side 1): TR Clear or FR Frosted (XLT option) glass (side 2): TR Clear or FR Frosted (XLT option)		

**ELECTRICAL**

(1) PANEL KIT Specify size of panel frame				(2) BASE SEGMENT Add base segment	(3) ADDITIONAL SEGMENT Specify as many segments as needed to complete panel					
HEIGHT	WIDTH	MODEL #	LIST	34"H FABRIC, FABRIC	8"H FABRIC, FABRIC	14"H FABRIC, FABRIC	14"H MARKER, FABRIC	14"H MARKER, MARKER	14"H GLAZED	18"H FABRIC, FABRIC
39"	24"	FHPK.3924E-D2	\$318	+ \$159	X	X	X	X	X	X
	30"	FHPK.3930E-D2	\$359	+ \$187	X	X	X	X	X	X
	36"	FHPK.3936E-D2	\$388	+ \$229	X	X	X	X	X	X
	42"	FHPK.3942E-D2	\$428	+ \$252	X	X	X	X	X	X
	48"	FHPK.3948E-D2	\$463	+ \$267	X	X	X	X	X	X
47"	24"	FHPK.4724E-D2	\$330	+ \$159	+ \$62	X	X	X	X	X
	30"	FHPK.4730E-D2	\$370	+ \$187	+ \$71	X	X	X	X	X
	36"	FHPK.4736E-D2	\$400	+ \$229	+ \$73	X	X	X	X	X
	42"	FHPK.4742E-D2	\$439	+ \$252	+ \$81	X	X	X	X	X
	48"	FHPK.4748E-D2	\$474	+ \$267	+ \$93	X	X	X	X	X
53"	24"	FHPK.5324E-D2	\$341	+ \$159	X	+ \$75	+ \$175	+ \$153	+ \$274	X
	30"	FHPK.5330E-D2	\$381	+ \$187	X	+ \$81	+ \$202	+ \$176	+ \$322	X
	36"	FHPK.5336E-D2	\$411	+ \$229	X	+ \$92	+ \$240	+ \$210	+ \$371	X
	42"	FHPK.5342E-D2	\$450	+ \$252	X	+ \$106	+ \$253	+ \$219	+ \$420	X
	48"	FHPK.5348E-D2	\$485	+ \$267	X	+ \$117	+ \$284	+ \$246	+ \$468	X
67"	24"	FHPK.6724E-D2	\$361	+ \$159	X	+ \$75	+ \$175	+ \$153	+ \$274	X
	30"	FHPK.6730E-D2	\$401	+ \$187	X	+ \$81	+ \$202	+ \$176	+ \$322	X
	36"	FHPK.6736E-D2	\$430	+ \$229	X	+ \$92	+ \$240	+ \$210	+ \$371	X
	42"	FHPK.6742E-D2	\$470	+ \$252	X	+ \$106	+ \$253	+ \$219	+ \$420	X
	48"	FHPK.6748E-D2	\$505	+ \$267	X	+ \$117	+ \$284	+ \$246	+ \$468	X
85"	24"	FHPK.8524E-D2	\$381	+ \$159	X	+ \$75	+ \$175	+ \$153	+ \$274	+ \$83
	30"	FHPK.8530E-D2	\$421	+ \$187	X	+ \$81	+ \$202	+ \$176	+ \$322	+ \$91
	36"	FHPK.8536E-D2	\$450	+ \$229	X	+ \$92	+ \$240	+ \$210	+ \$371	+ \$127
	42"	FHPK.8542E-D2	\$488	+ \$252	X	+ \$106	+ \$253	+ \$219	+ \$420	+ \$136
	48"	FHPK.8548E-D2	\$523	+ \$267	X	+ \$117	+ \$284	+ \$246	+ \$468	+ \$141

## Door Frames

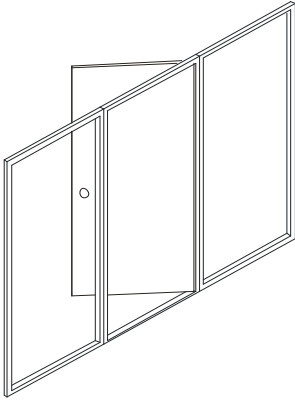

### DESCRIPTION

This door frame connects to an adjacent 85"H Frame. It comes with an 82-1/2"H door, a standard top cap, door knob, door stop, carpet grippers and hinges. Door Frame cannot be powered. Hinges and door knob have a satin aluminum finish standard

### NOTES

- Specify L for left hand swing, and R for right hand swing.

### SPECIFICATION OPTIONS

**product #:** see charts below

**base and top cap finish:** DT Dark Tone, MT Medium Tone, CW Cloud White

**door finish:** DT Dark Tone, MT Medium Tone, CW Cloud White

### ORDER EXAMPLE

**product #:** FHDOPA.8536L

**base and top cap finish:** DT Dark Tone, MT Medium Tone, CW Cloud White

**door finish:** DT Dark Tone, MT Medium Tone, CW Cloud White

PART #	HEIGHT	WIDTH	DEPTH	WT. (LBS)	LIST
FHDOPA.8536L	85-3/4"	36"	2-9/16"	—	\$3,642
FHDOPA.8536R	85-3/4"	36"	2-9/16"	—	\$3,642
FHDOPA.8542L	85-3/4"	42"	2-9/16"	—	\$3,642
FHDOPA.8542R	85-3/4"	42"	2-9/16"	—	\$3,642

## Draw Rod

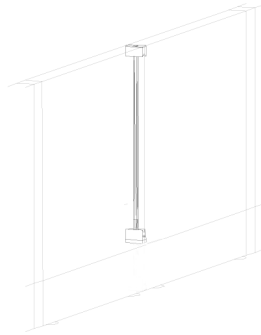

### DESCRIPTION

Panel hardware to connect two panels in a straight line.

### SPECIFICATION OPTIONS

**product #:** see charts below

### NOTES

- When connecting panels of different heights to each other, order draw rod change of height
- Draw rods are 5" shorter than the panel height

### ORDER EXAMPLE

**product #:** FDR.34

### DRAW ROD SAME HEIGHT



PART #	HEIGHT	WIDTH	DEPTH	WT. (LBS)	LIST
FDRSH.34	34"	—	—	1	\$20
FDRSH.42	42"	—	—	1	\$20
FDRSH.48	48"	—	—	1	\$21
FDRSH.62	62"	—	—	1	\$21
FDRSH.80	80"	—	—	2	\$21

### NOTES

Rod and block assembly connects two panels of the same height

### DRAW ROD CHANGE OF HEIGHT



PART #	HEIGHT	WIDTH	DEPTH	WT. (LBS)	LIST
FDRCH.34	34"	—	—	2	\$32
FDRCH.42	42"	—	—	2	\$32
FDRCH.48	48"	—	—	2	\$37
FDRCH.62	62"	—	—	2	\$37
FDRCH.80	80"	—	—	4	\$37

### NOTES

Rod and block assembly connects two panels at 180° (straight line) when the panels are of different height.

Order the height of the shorter panel.

Includes hanger rail and draw rod to match the height of the shorter panel.

### DRAW ROD WALL START/ POWER POLE

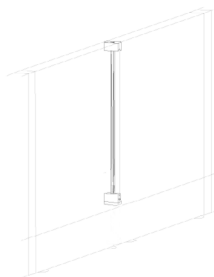

PART #	HEIGHT	WIDTH	DEPTH	WT. (LBS)	LIST
FDR.34	34"	—	—	1	\$20
FDR.42	42"	—	—	1	\$20
FDR.48	48"	—	—	1	\$21
FDR.62	62"	—	—	1	\$21
FDR.80	80"	—	—	2	\$21

### NOTES

Rod and block assembly for use at wall start or power pole installed at end of run.

## Connectors

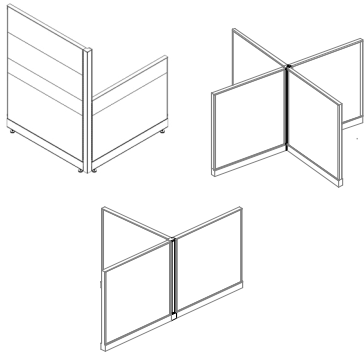

**DESCRIPTION**

Panel hardware to connect 2, 3 or 4 panels.

**SPECIFICATION OPTIONS**

**product #:** see charts below  
**finish:** DT Dark Tone, MT Medium Tone, CW Cloud White

**NOTES**

- Includes connector top cap

**ORDER EXAMPLE**

**product #:** FH2W.39  
**finish:** DT

### 2-WAY 90° CONNECTOR POST HARD SURFACE

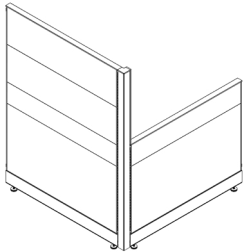

PART #	HEIGHT	WIDTH	DEPTH	WT. (LBS)	LIST
FH2W.39	39"	3.5"	3.5"	4	\$117
FH2W.47	47"	3.5"	3.5"	5	\$131
FH2W.53	53"	3.5"	3.5"	6	\$138
FH2W.67	67"	3.5"	3.5"	7	\$151
FH2W.85	85"	3.5"	3.5"	8	\$167

**NOTES**

Connects 2 panels at 90°.

### 3-WAY 90° CONNECTOR POST HARD SURFACE

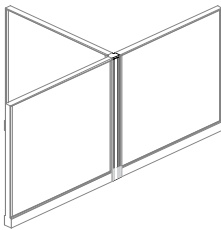

PART #	HEIGHT	WIDTH	DEPTH	WT. (LBS)	LIST
FH3W.39	39"	3.5"	3.5"	5	\$134
FH3W.47	47"	3.5"	3.5"	6	\$154
FH3W.53	53"	3.5"	3.5"	7	\$168
FH3W.67	67"	3.5"	3.5"	8	\$200
FH3W.85	85"	3.5"	3.5"	9	\$224

**NOTES**

Connects 3 panels at 90°.

Includes cable management trim cover and top cap

### 4-WAY 90° CONNECTOR POST HARD SURFACE

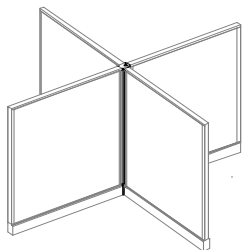

PART #	HEIGHT	WIDTH	DEPTH	WT. (LBS)	LIST
FH4W.39	39"	3.5"	3.5"	6	\$136
FH4W.47	47"	3.5"	3.5"	7	\$166
FH4W.53	53"	3.5"	3.5"	8	\$175
FH4W.67	67"	3.5"	3.5"	10	\$234
FH4W.85	85"	3.5"	3.5"	10	\$285

**NOTES**

Connects 4 panels at 90°.

Includes top cap

### 2-WAY 120° CONNECTOR POST HARD SURFACE

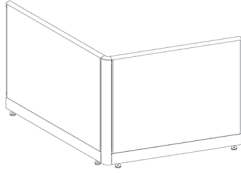

PART #	HEIGHT	WIDTH	DEPTH	WT. (LBS)	LIST
FH2W120.39	39"	3.5	—	—	\$199
FH2W120.47	47"	3.5	—	—	\$222
FH2W120.53	53"	3.5	—	—	\$239
FH2W120.67	67"	3.5	—	—	\$279
FH2W120.85	85"	3.5	—	—	\$327

NOTES
Connects 2 panels at 120°.

### 2-WAY 135° CONNECTOR POST HARD SURFACE

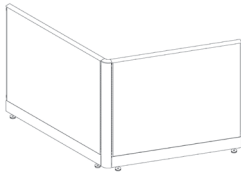

PART #	HEIGHT	WIDTH	DEPTH	WT. (LBS)	LIST
FH2W135.39	39"	3.5	—	—	\$195
FH2W135.47	47"	3.5	—	—	\$215
FH2W135.53	53"	3.5	—	—	\$231
FH2W135.67	67"	3.5	—	—	\$266
FH2W135.85	85"	3.5	—	—	\$308

NOTES
Connects 2 panels at 135°.

### 3-WAY 120° CONNECTOR POST HARD SURFACE

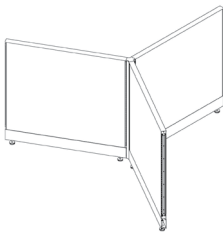

PART #	HEIGHT	WIDTH	DEPTH	WT. (LBS)	LIST
FH3W120.39	39"	3.5	—	—	\$195
FH3W120.47	47"	3.5	—	—	\$215
FH3W120.53	53"	3.5	—	—	\$231
FH3W120.67	67"	3.5	—	—	\$266
FH3W120.85	85"	3.5	—	—	\$308

NOTES
Connects 3 panels at 120°.

### FINISHED END



PART #	HEIGHT	WIDTH	DEPTH	WT. (LBS)	LIST
FHFE.39	39"	3.5"	1"	2	\$53
FHFE.47	47"	3.5"	1"	2	\$60
FHFE.53	53"	3.5"	1"	2	\$63
FHFE.67	67"	3.5"	1"	2	\$71
FHFE.85	85"	3.5"	1"	3	\$79

NOTES
Finishes the vertical end of a panel at the end of a panel run.
Includes the cable management trim cover.

## Connectors / continued

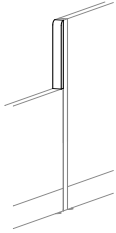
FINISHED END,  
CHANGE OF HEIGHT

PART #	HEIGHT	WIDTH	DEPTH	WT. (LBS)	LIST
FHFECH.6	6"	1.75"	.25"	1	\$63
FHFECH.8	8"	1.75"	.25"	1	\$63
FHFECH.14	14"	1.75"	.25"	1	\$63
FHFECH.18	18"	1.75"	.25"	2	\$63
FHFECH.20	20"	1.75"	.25"	2	\$63
FHFECH.28	28"	1.75"	.25"	3	\$63
FHFECH.32	32"	1.75"	.25"	3	\$63
FHFECH.38	38"	1.75"	.25"	3	\$63
FHFECH.46	46"	1.75"	.25"	3	\$63

## NOTES

Finishes the exposed end of a panel or connector at a change of height location.

Includes finished end trim and mounting hardware.

## WALL START

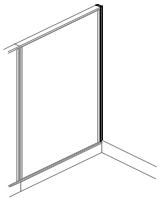

PART #	HEIGHT	WIDTH	DEPTH	WT. (LBS)	LIST
FWSTA.34	34"	1.75"	1"	2	\$43
FWSTA.42	42"	1.75"	1"	3	\$49
FWSTA.48	48"	1.75"	1"	3	\$55
FWSTA.62	62"	1.75"	1"	3	\$61
FWSTA.80	80"	1.75"	1"	4	\$68

## NOTES

Connects panel to structural wall or column. Can also connect equal height panels at a 90° angle at any point along the panel width.

Order one additional draw rod of the same height.

## WALL STRIP

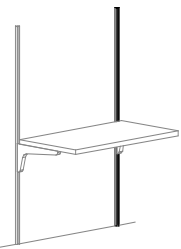

PART #	HEIGHT	WIDTH	DEPTH	WT. (LBS)	LIST
FWSST.60	60"	—	—	3	\$65
FWSST.72	72"	—	—	3	\$71
FWSST.84	84"	—	—	4	\$73

## NOTES

Attaches to structural wall to hang worksurfaces and/or components.

Includes one wall strip.

# Electrical Distribution

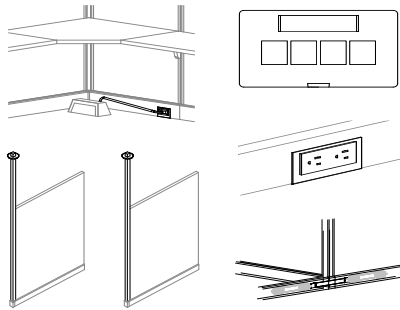

**DESCRIPTION**

Parts for distributing power through your system. Distributes up to four 20-amp circuits.

**NOTES**

- 4-circuit

**SPECIFICATION OPTIONS**

**product #:** see charts below  
**finish:** DT Dark Tone, MT Medium Tone, CW Cloud White

**ORDER EXAMPLE**

**product #:** FHBPE

## BASE POWER ENTRY DIRECT CONNECT, 4-CIRCUIT

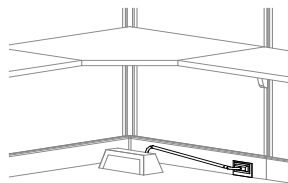

PART #	HEIGHT	WIDTH	DEPTH	WT. (LBS)	LIST
FHBPE	left angle elbow	—	—	5	\$290

**NOTES**  
 Connects building power from a wall, floor or column to the base of a panel.

Plugs directly into the panel's electrical harness at receptacle location.  
 Basefeed is approx 6 1/2 feet long  
 Distributes up to four 20-amp circuits.  
 Includes a cable that can be field-cut to the appropriate length.

**MUST BE WIRED BY A LICENSED ELECTRICIAN.**

## RECEPTACLE 4-CIRCUIT

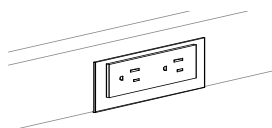

PART #	HEIGHT	WIDTH	DEPTH	WT. (LBS)	LIST
FHRECP4.I	circuit a			0.25	\$27
FHRECP4.II	circuit b			0.25	\$27
FHRECP4.III	circuit c			0.25	\$27
FHRECP4.IIII	circuit d, dedicated			0.25	\$27
FHRECP4.II-CONT	Circuit b			0.25	\$27
FHRECP4.III-CONT	Circuit c			0.25	\$27

**NOTES**  
 Locks into panel base power harness.  
 Provides access to I, II, III, or IIII circuit.  
 Provides dedicated circuit with "IIII" receptacle.  
 Receptacle -CONT are permanently marked CONTROLLED on the face of the receptacle and must be connected to a timer or motion sensor at the infeed location by a licensed electrician in order to comply with California T24

## DATA PORT PLATE

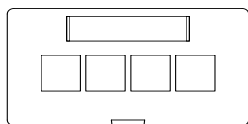

PART #	HEIGHT	WIDTH	DEPTH	WT. (LBS)	LIST
FHDPP	2.125"	3.625"	0.750"	0.10	\$39

**NOTES**  
 This Data Port plate is used at the base of a panel in unused duplex cutout to connect computers and/or communication equipment.

Data jacks should be top feed 90° type, not the back feed 180° type.

4 port locations and comes with 1 blank insert.

Available in CW or BU

## Electrical Distribution / continued

### CEILING POWER ENTRY INTERNAL DIRECT CONNECT 4-CIRCUIT

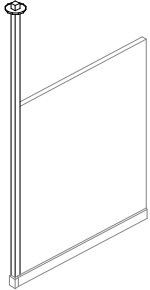

PART #	HEIGHT	WIDTH	DEPTH	WT. (LBS)	LIST
FHCPE4.39	39"	3.5"	3.5"	13	\$573
FHCPE4.47	47"	3.5"	3.5"	13	\$573
FHCPE4.53	53"	3.5"	3.5"	13	\$573
FHCPE4.67	67"	3.5"	3.5"	13	\$573
FHCPE4.85	85"	3.5"	3.5"	13	\$573

#### NOTES

Connects a ceiling electrical supply to the base of a powered panel. Distributes up to four 20-amp circuits. Attaches to the end of a panel run, or to a 3 or 4-way 90° connector. To attach the Power Pole at the end of a panel run, order a Draw Rod separately. Infeed is approx 14 1/2 feet long.

To attach at a:

- 2-Way connection point, order a 3-Way connector
- 3-Way connection point, order a 4-Way connector

Includes a rigid conduit and conduit connector, factory installed power harness, 12' pole, bezel and end cap trim cover.

Available in MT, DT and CW only.

**MUST BE WIRED BY A LICENSED ELECTRICIAN.**

### CEILING DATA ENTRY NON-POWERED

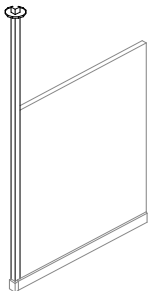

PART #	HEIGHT	WIDTH	DEPTH	WT. (LBS)	LIST
FHCDE.39	39"	3.5"	3.5"	8	\$258
FHCDE.47	47"	3.5"	3.5"	8	\$258
FHCDE.53	53"	3.5"	3.5"	8	\$258
FHCDE.67	67"	3.5"	3.5"	8	\$258
FHCDE.85	85"	3.5"	3.5"	8	\$258

#### NOTES

Routes data/telecommunication cables from the ceiling to the base of a panel. Attaches to the end of a panel run, to a 3 or 4-Way 90° connector. To attach the Power Pole at the end of a panel run, order a Draw Rod separately.

To attach at a:

- 2-Way connection point, order a 3-Way connector
- 3-Way connection point, order a 4-Way connector

Includes a 12' pole, bezel, and end cap trim cover.

Available in MT, DT and CW only.

### POWER FESTOON PANEL THROUGH POST

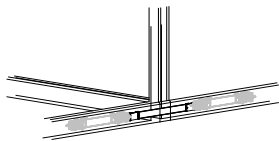

PART #	HEIGHT	WIDTH	DEPTH	WT. (LBS)	LIST
FHCPK.1	23"	—	—	1	\$73

#### NOTES

Extends power in a straight line through 3-Way or 4-Way connector. Extends power through a 120° or 135° 2 or 3 way connector.

### POWER FESTOON 90° ANGLE

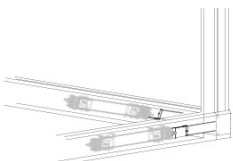

PART #	HEIGHT	WIDTH	DEPTH	WT. (LBS)	LIST
FHCPK.90	—	—	—	1	\$73

#### NOTES

Extends power at a 90° angle through a 2-Way, 3-Way or 4-Way connector.



**POWER PANEL  
CONVERSION KIT**

PART #	HEIGHT	WIDTH	DEPTH	WT. (LBS)	LIST
FHPPCK.24	—	24"	—	1	\$378
FHPPCK.30	—	30"	—	2	\$422
FHPPCK.36	—	36"	—	2	\$497
FHPPCK.42	—	42"	—	2	\$561
FHPPCK.48	—	48"	—	3	\$624

**NOTES**

Includes:

- Power Retro
- Base Cover with power cutouts
- Panel to panel festoon

Order duplex outlets separately.

Specify base material: plastic or metal

Specify base finish: DT, MT, CW

Metal conversion kit has \$29 upcharge.

Order the Power Festoon Through Post if you are converting a non-electrical panel in a straight line through a 3-Way or 4-Way connection.

Order the Power Festoon 90° Angle if you are converting a non-electrical panel at a 90° angle through a 2-Way, 3-Way or 4-Way connection.

## Rectangular

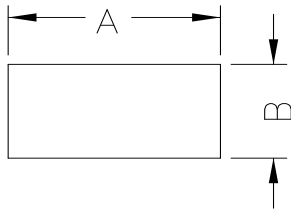
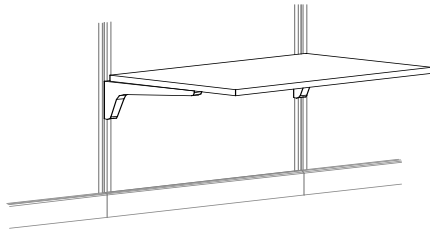

### DESCRIPTION

Worksurface hangs from a panel or wall strips. It has a laminate top and a PVC edge. There is a 1" gap at the back of the worksurface for plug and cord passage. 60" to 84" worksurfaces have a center support. Includes cantilever brackets and attachment hardware.

### NOTES

When ordering a worksurface spanning a panel and a 3-Way, or 2 panels with a 3-way in between the panels, you will need to:

- add 3.5" to the length of the worksurface
- add "-3W" to the part number
- add \$80 to the list price

### SPECIFICATION OPTIONS

**product #:** see charts below  
**worksurface finish:** see page 6  
**edge finish:** see page 6  
**support finish:** DT Dark Tone, MT Medium Tone, CW Cloud White

### ORDER EXAMPLE

**product #:** FHERWS.2424L  
**worksurface finish:** M1 Light Maple  
**edge finish:** M1 Light Maple  
**support finish:** E9 Cloud White

### 24" D WORKSURFACES

PART #	HEIGHT	A	B	C	D	WT. (LBS)	LIST
FHERWS.2424L	1.25"	24"	24"	—	—	30	\$185
FHERWS.2430L	1.25"	30"	24"	—	—	36	\$212
FHERWS.2436L	1.25"	36"	24"	—	—	41	\$219
FHERWS.2442L	1.25"	42"	24"	—	—	47	\$269
FHERWS.2448L	1.25"	48"	24"	—	—	53	\$276
FHERWS.2454L	1.25"	54"	24"	—	—	58	\$316
FHERWS.2460L	1.25"	60"	24"	—	—	64	\$343
FHERWS.2466L	1.25"	66"	24"	—	—	70	\$384
FHERWS.2472L	1.25"	72"	24"	—	—	76	\$393
FHERWS.2478L	1.25"	78"	24"	—	—	81	\$462
FHERWS.2484L	1.25"	84"	24"	—	—	87	\$466

### 30" D WORKSURFACES

PART #	HEIGHT	A	B	C	D	WT. (LBS)	LIST
FHERWS.3024L	1.25"	24"	30"	—	—	38	\$246
FHERWS.3030L	1.25"	30"	30"	—	—	45	\$281
FHERWS.3036L	1.25"	36"	30"	—	—	53	\$288
FHERWS.3042L	1.25"	42"	30"	—	—	60	\$346
FHERWS.3048L	1.25"	48"	30"	—	—	66	\$354
FHERWS.3054L	1.25"	54"	30"	—	—	74	\$402
FHERWS.3060L	1.25"	60"	30"	—	—	81	\$430
FHERWS.3066L	1.25"	66"	30"	—	—	88	\$480
FHERWS.3072L	1.25"	72"	30"	—	—	95	\$490
FHERWS.3078L	1.25"	78"	30"	—	—	103	\$575
FHERWS.3084L	1.25"	84"	30"	—	—	111	\$579

# Wedge

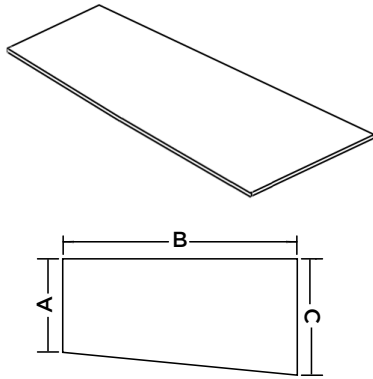

## DESCRIPTION

Worksurface hangs from frames or wall strips. It has a laminate top and a PVC edge.

## NOTES

- 78" and 84" worksurfaces will accept a 42" or 36"W lateral file
- 72"W worksurface will accept a 36"W lateral file
- 66"W worksurface will accept a 30"W lateral file
- Worksurfaces shorter than 48"W will not accept a pedestal
- Includes cantilever brackets and attachment hardware

## SPECIFICATION OPTIONS

**product #:** see charts below  
**worksurface finish:** see page 6  
**edge finish:** see page 6

## ORDER EXAMPLE

**product #:** FHWDWS.243030  
**worksurface finish:** M1 Light Maple  
**edge finish:** M1 Light Maple

### 24" D LEFT 30" D RIGHT

PART #	HEIGHT	A	B	C	D	WT. (LBS)	LIST
FHWDWS.243030	1.25"	24"	30"	30"	—	40	\$281
FHWDWS.243630	1.25"	24"	36"	30"	—	46	\$288
FHWDWS.244230	1.25"	24"	42"	30"	—	53	\$346
FHWDWS.244830	1.25"	24"	48"	30"	—	60	\$354
FHWDWS.245430	1.25"	24"	54"	30"	—	66	\$402
FHWDWS.246030	1.25"	24"	60"	30"	—	74	\$430
FHWDWS.246630	1.25"	24"	66"	30"	—	81	\$480
FHWDWS.247230	1.25"	24"	72"	30"	—	88	\$490
FHWDWS.247830	1.25"	24"	78"	30"	—	95	\$575
FHWDWS.248430	1.25"	24"	84"	30"	—	102	\$579

### 24" D RIGHT 30" D LEFT

PART #	HEIGHT	A	B	C	D	WT. (LBS)	LIST
FHWDWS.303024	1.25"	30"	30"	24"	—	40	\$281
FHWDWS.303624	1.25"	30"	36"	24"	—	46	\$288
FHWDWS.304224	1.25"	30"	42"	24"	—	53	\$346
FHWDWS.304824	1.25"	30"	48"	24"	—	60	\$354
FHWDWS.305424	1.25"	30"	54"	24"	—	66	\$402
FHWDWS.306024	1.25"	30"	60"	24"	—	74	\$430
FHWDWS.306624	1.25"	30"	66"	24"	—	81	\$480
FHWDWS.307224	1.25"	30"	72"	24"	—	88	\$490
FHWDWS.307824	1.25"	30"	78"	24"	—	95	\$575
FHWDWS.308424	1.25"	30"	84"	24"	—	102	\$579

## 90° Notched and Curved Corner

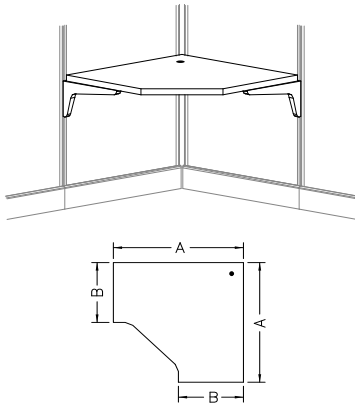

### DESCRIPTION

Worksurface hangs from a panel or wall strips. It has a laminate top and a PVC edge. There is a 1" gap at the back of the worksurface for plug and cord passage. It has 24"D or 30"D connecting sides. Includes cantilever brackets and attachment hardware.

### NOTES

- Includes one wire grommet, cantilever brackets, one corner bracket, and attachment hardware.
- \*Corners are angled (not available with notched front edge)

### SPECIFICATION OPTIONS

**product #:** see charts below  
**worksurface finish:** see page 6  
**edge finish:** see page 6  
**support finish:** DT Dark Tone, MT Medium Tone, CW Cloud White

### ORDER EXAMPLE

**product #:** FHECWS.2436L  
**worksurface finish:** M1 Light Maple  
**edge finish:** M1 Light Maple  
**support finish:** E9 Cloud White

### 90° NOTCHED CORNER

PART #	HEIGHT	A	B	C	D	WT. (LBS)	LIST	NOTES
FHECWS.2436L	1.25"	36" *	24"	—	—	53	\$356	* Corners are angled (not available with notched front edge)
FHECWS.2442L	1.25"	42"	24"	—	—	72	\$440	
FHECWS.2448L	1.25"	48"	24"	—	—	83	\$466	
FHECWS.3036L	1.25"	36" *	30"	—	—	60	\$395	
FHECWS.3042L	1.25"	42" *	30"	—	—	74	\$479	
FHECWS.3048L	1.25"	48"	30"	—	—	85	\$504	

### 90° CURVED CORNER

PART #	HEIGHT	A	B	C	D	WT. (LBS)	LIST
FHECCWS.2436L	1.25"	36"	24"	—	—	54	\$356
FHECCWS.2442L	1.25"	42"	24"	—	—	68	\$440
FHECCWS.2448L	1.25"	48"	24"	—	—	72	\$466
FHECCWS.3036L	1.25"	36"	30"	—	—	60	\$395
FHECCWS.3042L	1.25"	42"	30"	—	—	76	\$479
FHECCWS.3048L	1.25"	48"	30"	—	—	78	\$504

## Square Edge Half Circle

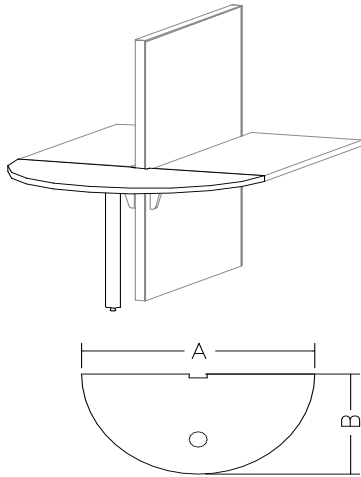

### DESCRIPTION

This Half Circle worksurface has a notch and attaches to the end of two back to back rectangular or extended corner worksurfaces, and includes one support column leg. It has a laminate top and a PVC edge.

### NOTES

- Support column leg has a leveling glide and attaching hardware
- Ships knocked down
- Column leg finish matches support.

### SPECIFICATION OPTIONS

**product #:** see charts below  
**worksurface finish:** see page 6  
**edge finish:** see page 6  
**support finish:** DT Dark Tone, CW Cloud White

### ORDER EXAMPLE

**product #:** FHEHCWS.50L  
**worksurface finish:** M1 Light Maple  
**edge finish:** M1 Light Maple  
**support finish:** E9 Cloud White

### SQUARE EDGE HALF CIRCLE

PART #	HEIGHT	A	B	C	D	WT. (LBS)	LIST
FHEHCWS.50L	29"	52"	26"	—	—	55	\$640
FHEHCWS.60L	29"	64"	32"	—	—	67	\$722

## Square Edge D-Shaped

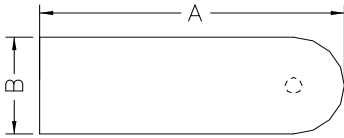
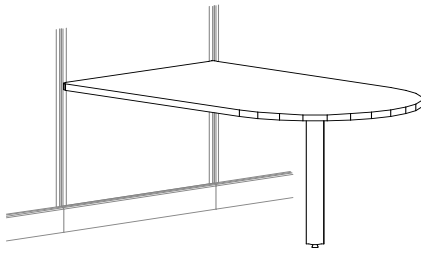

### DESCRIPTION

Worksurface hangs from a panel or wall strips. It has a laminate top and a PVC edge. There is a 1" gap at the back of the worksurface for plug and cord passage. Includes one support column leg.

### NOTES

- Support column leg has a leveling glide and attaching hardware
- Ships knocked down
- Column leg finish matches support.

### SPECIFICATION OPTIONS

**product #:** see charts below  
**worksurface finish:** see page 6  
**edge finish:** see page 6  
**support finish:** DT Dark Tone, MT Medium Tone, CW Cloud White

### ORDER EXAMPLE

**product #:** FHEDSP.2448L  
**worksurface finish:** M1 Light Maple  
**edge finish:** M1 Light Maple  
**support finish:** E9 Cloud White

### SQUARE EDGE D-SHAPED

PART #	HEIGHT	A	B	C	D	WT. (LBS)	LIST
FHEDSP.2448L	29"	48"	24"	—	—	62	\$404
FHEDSP.3048L	29"	48"	30"	—	—	72	\$442
FHEDSP.2460L	29"	60"	24"	—	—	73	\$450
FHEDSP.3060L	29"	60"	30"	—	—	87	\$490
FHEDSP.3072L	29"	72"	30"	—	—	101	\$536
FHEDSP.3672L	29"	72"	36"	—	—	117	\$591

## 90° Extended Notched Corner

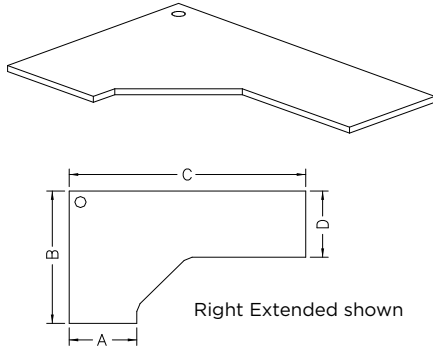

### DESCRIPTION

Worksurface hangs from a panel or wall strips. It has a laminate top and a PVC edge. There is a 1" gap at the back of the worksurface for plug and cord passage. 60" to 84" worksurfaces have a center support.

### NOTES

- Includes one wire grommet, cantilever brackets, one corner bracket, and attachment hardware
- Specify L for left extended, and R for right extended.

When ordering a worksurface spanning a panel and a 3-Way or spacer connector or 2 panels with a 3-Way or spacer connector in between the panels, you will need to:

- add 3.5" to the length of the worksurface
- add "-3W" to the part number
- add \$80 to the list price

Please note: the spacer connector can only be added to the "C" side

### SPECIFICATION OPTIONS

**product #:** see charts below  
**worksurface finish:** see page 6  
**edge finish:** see page 6  
**support finish:** DT Dark Tone, MT Medium Tone, CW Cloud White  
**left or right extended:** L for Left, R for Right

### ORDER EXAMPLE

**product #:** FHENCWS.24363024L  
**worksurface finish:** M1 Light Maple  
**edge finish:** M1 Light Maple  
**support finish:** E9 Cloud White  
**left or right extended:** L

### 24" D CONNECTING SIDE 24" D EXTENSION 36" D

PART #	HEIGHT	A	B	C	D	WT. (LBS)	LIST
FHENCWS.24366024L	1.25"	24"	36"	60"	24"	74	\$452
FHENCWS.24366024R	1.25"	24"	36"	60"	24"	74	\$452
FHENCWS.24366624L	1.25"	24"	36"	66"	24"	81	\$504
FHENCWS.24366624R	1.25"	24"	36"	66"	24"	81	\$504
FHENCWS.24367224L	1.25"	24"	36"	72"	24"	87	\$512
FHENCWS.24367224R	1.25"	24"	36"	72"	24"	87	\$512
FHENCWS.24367824L	1.25"	24"	36"	78"	24"	93	\$614
FHENCWS.24367824R	1.25"	24"	36"	78"	24"	93	\$614
FHENCWS.24368424L	1.25"	24"	36"	84"	24"	99	\$621
FHENCWS.24368424R	1.25"	24"	36"	84"	24"	99	\$621

## 90° Extended Notched Corner / continued

**30" D CONNECTING SIDE  
30" D EXTENSION  
36" D**

PART #	HEIGHT	A	B	C	D	WT. (LBS)	LIST
FHENCWS.30366030L	1.25"	30"	36"	60"	30"	88	\$494
FHENCWS.30366030R	1.25"	30"	36"	60"	30"	88	\$494
FHENCWS.30366630L	1.25"	30"	36"	66"	30"	95	\$546
FHENCWS.30366630R	1.25"	30"	36"	66"	30"	95	\$546
FHENCWS.30367230L	1.25"	30"	36"	72"	30"	102	\$554
FHENCWS.30367230R	1.25"	30"	36"	72"	30"	102	\$554
FHENCWS.30367830L	1.25"	30"	36"	78"	30"	110	\$656
FHENCWS.30367830R	1.25"	30"	36"	78"	30"	110	\$656
FHENCWS.30368430L	1.25"	30"	36"	84"	30"	117	\$662
FHENCWS.30368430R	1.25"	30"	36"	84"	30"	117	\$662

**24" D CONNECTING SIDE  
24" D EXTENSION  
42" D**

PART #	HEIGHT	A	B	C	D	WT. (LBS)	LIST
FHENCWS.24426024L	1.25"	24"	42"	60"	24"	84	\$544
FHENCWS.24426024R	1.25"	24"	42"	60"	24"	84	\$544
FHENCWS.24426624L	1.25"	24"	42"	66"	24"	91	\$612
FHENCWS.24426624R	1.25"	24"	42"	66"	24"	91	\$612
FHENCWS.24427224L	1.25"	24"	42"	72"	24"	97	\$621
FHENCWS.24427224R	1.25"	24"	42"	72"	24"	97	\$621
FHENCWS.24427824L	1.25"	24"	42"	78"	24"	103	\$753
FHENCWS.24427824R	1.25"	24"	42"	78"	24"	103	\$753
FHENCWS.24428424L	1.25"	24"	42"	84"	24"	109	\$762
FHENCWS.24428424R	1.25"	24"	42"	84"	24"	109	\$762

**30" D CONNECTING SIDE  
30" D EXTENSION  
42" D**

PART #	HEIGHT	A	B	C	D	WT. (LBS)	LIST
FHENCWS.30426030L	1.25"	30"	42"	60"	30"	98	\$586
FHENCWS.30426030R	1.25"	30"	42"	60"	30"	98	\$586
FHENCWS.30426630L	1.25"	30"	42"	66"	30"	106	\$654
FHENCWS.30426630R	1.25"	30"	42"	66"	30"	106	\$654
FHENCWS.30427230L	1.25"	30"	42"	72"	30"	112	\$663
FHENCWS.30427230R	1.25"	30"	42"	72"	30"	112	\$663
FHENCWS.30427830L	1.25"	30"	42"	78"	30"	122	\$795
FHENCWS.30427830R	1.25"	30"	42"	78"	30"	122	\$795
FHENCWS.30428430L	1.25"	30"	42"	84"	30"	127	\$804
FHENCWS.30428430R	1.25"	30"	42"	84"	30"	127	\$804



**24" D CONNECTING SIDE  
24" D EXTENSION  
48" D**

PART #	HEIGHT	A	B	C	D	WT. (LBS)	LIST
FHENCWS.24486024L	1.25"	24"	48"	60"	24"	93	\$552
FHENCWS.24486024R	1.25"	24"	48"	60"	24"	93	\$552
FHENCWS.24486624L	1.25"	24"	48"	66"	24"	99	\$621
FHENCWS.24486624R	1.25"	24"	48"	66"	24"	99	\$621
FHENCWS.24487224L	1.25"	24"	48"	72"	24"	104	\$635
FHENCWS.24487224R	1.25"	24"	48"	72"	24"	104	\$635
FHENCWS.24487824L	1.25"	24"	48"	78"	24"	110	\$774
FHENCWS.24487824R	1.25"	24"	48"	78"	24"	110	\$774
FHENCWS.24488424L	1.25"	24"	48"	84"	24"	116	\$778
FHENCWS.24488424R	1.25"	24"	48"	84"	24"	116	\$778

**30" D CONNECTING SIDE  
30" D EXTENSION  
48" D**

PART #	HEIGHT	A	B	C	D	WT. (LBS)	LIST
FHENCWS.30486030L	1.25"	30"	48"	60"	30"	108	\$595
FHENCWS.30486030R	1.25"	30"	48"	60"	30"	108	\$595
FHENCWS.30486630L	1.25"	30"	48"	66"	30"	116	\$663
FHENCWS.30486630R	1.25"	30"	48"	66"	30"	116	\$663
FHENCWS.30487230L	1.25"	30"	48"	72"	30"	123	\$678
FHENCWS.30487230R	1.25"	30"	48"	72"	30"	123	\$678
FHENCWS.30487830L	1.25"	30"	48"	78"	30"	134	\$816
FHENCWS.30487830R	1.25"	30"	48"	78"	30"	134	\$816
FHENCWS.30488430L	1.25"	30"	48"	84"	30"	146	\$820
FHENCWS.30488430R	1.25"	30"	48"	84"	30"	146	\$820

## 90° Extended Curved Corner

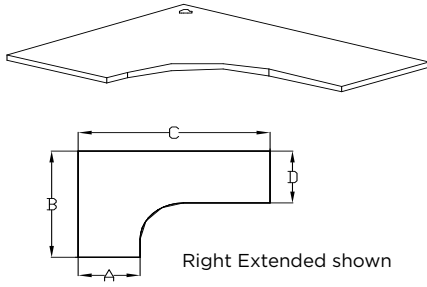

### DESCRIPTION

Worksurface hangs from a panel or wall strips. It has a laminate top and a PVC edge. There is a 1" gap at the back of the worksurface for plug and cord passage. 60" to 84" worksurfaces have a center support.

### NOTES

- Includes one wire grommet, cantilever brackets, one corner bracket, and attachment hardware
- Specify L for left extended, and R for right extended.

When ordering a worksurface spanning a panel and a 3-Way or spacer connector or 2 panels with a 3-Way or spacer connector in between the panels, you will need to:

- add 3.5" to the length of the worksurface
- add "-3W" to the part number
- add \$80 to the list price

Please note: the spacer connector can only be added to the "C" side

### SPECIFICATION OPTIONS

**product #:** see charts below  
**worksurface finish:** see page 6  
**edge finish:** see page 6  
**support finish:** DT Dark Tone, MT Medium Tone, CW Cloud White  
**left or right extended:** L for Left, R for Right

### ORDER EXAMPLE

**product #:** FHECCWWS.24366024L  
**worksurface finish:** M1 Light Maple  
**edge finish:** M1 Light Maple  
**support finish:** E9 Cloud White  
**left or right extended:** L

### 24" D CONNECTING SIDE 24" D EXTENSION 36" D

PART #	HEIGHT	A	B	C	D	WT. (LBS)	LIST
FHECCWS.24366024L	1.25"	24"	36"	60"	24"	76	\$452
FHECCWS.24366024R	1.25"	24"	36"	60"	24"	76	\$452
FHECCWS.24366624L	1.25"	24"	36"	66"	24"	82	\$504
FHECCWS.24366624R	1.25"	24"	36"	66"	24"	82	\$504
FHECCWS.24367224L	1.25"	24"	36"	72"	24"	88	\$512
FHECCWS.24367224R	1.25"	24"	36"	72"	24"	88	\$512
FHECCWS.24367824L	1.25"	24"	36"	78"	24"	94	\$614
FHECCWS.24367824R	1.25"	24"	36"	78"	24"	94	\$614
FHECCWS.24368424L	1.25"	24"	36"	84"	24"	100	\$620
FHECCWS.24368424R	1.25"	24"	36"	84"	24"	100	\$620

**30" D CONNECTING SIDE  
30" D EXTENSION  
36" D**

PART #	HEIGHT	A	B	C	D	WT. (LBS)	LIST
FHECCWS.30366030L	1.25"	30"	36"	60"	30"	87	\$494
FHECCWS.30366030R	1.25"	30"	36"	60"	30"	87	\$494
FHECCWS.30366630L	1.25"	30"	36"	66"	30"	95	\$546
FHECCWS.30366630R	1.25"	30"	36"	66"	30"	95	\$546
FHECCWS.30367230L	1.25"	30"	36"	72"	30"	102	\$554
FHECCWS.30367230R	1.25"	30"	36"	72"	30"	102	\$554
FHECCWS.30367830L	1.25"	30"	36"	78"	30"	110	\$656
FHECCWS.30367830R	1.25"	30"	36"	78"	30"	110	\$656
FHECCWS.30368430L	1.25"	30"	36"	84"	30"	117	\$662
FHECCWS.30368430R	1.25"	30"	36"	84"	30"	117	\$662

**24" D CONNECTING SIDE  
24" D EXTENSION  
42" D**

PART #	HEIGHT	A	B	C	D	WT. (LBS)	LIST
FHECCWS.24426024L	1.25"	24"	42"	60"	24"	83	\$544
FHECCWS.24426024R	1.25"	24"	42"	60"	24"	83	\$544
FHECCWS.24426624L	1.25"	24"	42"	66"	24"	89	\$612
FHECCWS.24426624R	1.25"	24"	42"	66"	24"	89	\$612
FHECCWS.24427224L	1.25"	24"	42"	72"	24"	95	\$621
FHECCWS.24427224R	1.25"	24"	42"	72"	24"	95	\$621
FHECCWS.24427824L	1.25"	24"	42"	78"	24"	101	\$753
FHECCWS.24427824R	1.25"	24"	42"	78"	24"	101	\$753
FHECCWS.24428424L	1.25"	24"	42"	84"	24"	106	\$762
FHECCWS.24428424R	1.25"	24"	42"	84"	24"	106	\$762

**30" D CONNECTING SIDE  
30" D EXTENSION  
42" D**

PART #	HEIGHT	A	B	C	D	WT. (LBS)	LIST
FHECCWS.30426030L	1.25"	30"	42"	60"	30"	95	\$586
FHECCWS.30426030R	1.25"	30"	42"	60"	30"	95	\$586
FHECCWS.30426630L	1.25"	30"	42"	66"	30"	103	\$654
FHECCWS.30426630R	1.25"	30"	42"	66"	30"	103	\$654
FHECCWS.30427230L	1.25"	30"	42"	72"	30"	110	\$663
FHECCWS.30427230R	1.25"	30"	42"	72"	30"	110	\$663
FHECCWS.30427830L	1.25"	30"	42"	78"	30"	118	\$795
FHECCWS.30427830R	1.25"	30"	42"	78"	30"	118	\$795
FHECCWS.30428430L	1.25"	30"	42"	84"	30"	125	\$804
FHECCWS.30428430R	1.25"	30"	42"	84"	30"	125	\$804

## 90° Extended Curved Corner / continued

**24" D CONNECTING SIDE**  
**24" D EXTENSION**  
**48" D**

PART #	HEIGHT	A	B	C	D	WT. (LBS)	LIST
FHECCWS.24486024L	1.25"	24"	48"	60"	24"	89	\$552
FHECCWS.24486024R	1.25"	24"	48"	60"	24"	89	\$552
FHECCWS.24486624L	1.25"	24"	48"	66"	24"	95	\$621
FHECCWS.24486624R	1.25"	24"	48"	66"	24"	95	\$621
FHECCWS.24487224L	1.25"	24"	48"	72"	24"	101	\$635
FHECCWS.24487224R	1.25"	24"	48"	72"	24"	101	\$635
FHECCWS.24487824L	1.25"	24"	48"	78"	24"	107	\$774
FHECCWS.24487824R	1.25"	24"	48"	78"	24"	107	\$774
FHECCWS.24488424L	1.25"	24"	48"	84"	24"	112	\$778
FHECCWS.24488424R	1.25"	24"	48"	84"	24"	112	\$778

**30" D CONNECTING SIDE**  
**30" D EXTENSION**  
**48" D**

PART #	HEIGHT	A	B	C	D	WT. (LBS)	LIST
FHECCWS.30486030L	1.25"	30"	48"	60"	30"	104	\$595
FHECCWS.30486030R	1.25"	30"	48"	60"	30"	104	\$595
FHECCWS.30486630L	1.25"	30"	48"	66"	30"	112	\$663
FHECCWS.30486630R	1.25"	30"	48"	66"	30"	112	\$663
FHECCWS.30487230L	1.25"	30"	48"	72"	30"	119	\$678
FHECCWS.30487230R	1.25"	30"	48"	72"	30"	119	\$678
FHECCWS.30487830L	1.25"	30"	48"	78"	30"	126	\$816
FHECCWS.30487830R	1.25"	30"	48"	78"	30"	126	\$816
FHECCWS.30488430L	1.25"	30"	48"	84"	30"	133	\$820
FHECCWS.30488430R	1.25"	30"	48"	84"	30"	133	\$820

## 90° Extended Notched Corner Peninsula

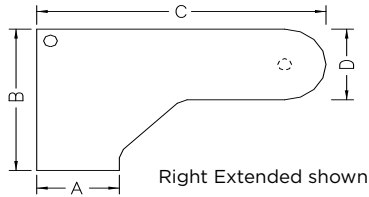
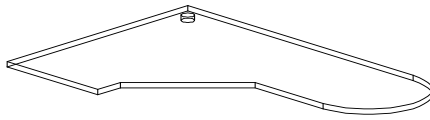

### DESCRIPTION

Worksurface hangs from a panel or wall strips. It has a laminate top and a PVC edge. There is a 1" gap at the back of the worksurface for plug and cord passage.

### SPECIFICATION OPTIONS

**product #:** see charts below  
**worksurface finish:** see page 6  
**edge finish:** see page 6  
**support finish:** DT Dark Tone, MT Medium Tone, CW Cloud White  
**left or right extended:** L for Left, R for Right

### NOTES

- Includes one wire grommet, cantilever brackets, one corner bracket, and attachment hardware
- Specify L for left extended, and R for right extended
- Includes one support column leg
- Column leg finish matches support

### ORDER EXAMPLE

**product #:** FHENCPWS.24366024L  
**worksurface finish:** M1 Light Maple  
**edge finish:** M1 Light Maple  
**support finish:** E9 Cloud White  
**left or right extended:** L

### 24" D CONNECTING SIDE 24" D EXTENSION 36" D

PART #	HEIGHT	A	B	C	D	WT. (LBS)	LIST
FHENCPWS.24366024L	1.25"	24"	36"	60"	24"	89	\$620
FHENCPWS.24366024R	1.25"	24"	36"	60"	24"	89	\$620
FHENCPWS.24366624L	1.25"	24"	36"	66"	24"	95	\$681
FHENCPWS.24366624R	1.25"	24"	36"	66"	24"	95	\$681
FHENCPWS.24367224L	1.25"	24"	36"	72"	24"	101	\$695
FHENCPWS.24367224R	1.25"	24"	36"	72"	24"	101	\$695
FHENCPWS.24367824L	1.25"	24"	36"	78"	24"	107	\$807
FHENCPWS.24367824R	1.25"	24"	36"	78"	24"	107	\$807
FHENCPWS.24368424L	1.25"	24"	36"	84"	24"	112	\$823
FHENCPWS.24368424R	1.25"	24"	36"	84"	24"	112	\$823

### 24" D CONNECTING SIDE 24" D EXTENSION 42" D

PART #	HEIGHT	A	B	C	D	WT. (LBS)	LIST
FHENCPWS.24426024L	1.25"	24"	42"	60"	24"	97	\$704
FHENCPWS.24426024R	1.25"	24"	42"	60"	24"	97	\$704
FHENCPWS.24426624L	1.25"	24"	42"	66"	24"	103	\$781
FHENCPWS.24426624R	1.25"	24"	42"	66"	24"	103	\$781
FHENCPWS.24427224L	1.25"	24"	42"	72"	24"	109	\$795
FHENCPWS.24427224R	1.25"	24"	42"	72"	24"	109	\$795
FHENCPWS.24427824L	1.25"	24"	42"	78"	24"	114	\$966
FHENCPWS.24427824R	1.25"	24"	42"	78"	24"	114	\$966
FHENCPWS.24428424L	1.25"	24"	42"	84"	24"	120	\$970
FHENCPWS.24428424R	1.25"	24"	42"	84"	24"	120	\$970

## 90° Extended Notched Corner Peninsula / continued

**24" D CONNECTING SIDE  
24" D EXTENSION  
48" D**

PART #	HEIGHT	A	B	C	D	WT. (LBS)	LIST
FHENCPCS.24486024L	1.25"	24"	48"	60"	24"	104	\$708
FHENCPCS.24486024R	1.25"	24"	48"	60"	24"	104	\$708
FHENCPCS.24486624L	1.25"	24"	48"	66"	24"	110	\$785
FHENCPCS.24486624R	1.25"	24"	48"	66"	24"	110	\$785
FHENCPCS.24487224L	1.25"	24"	48"	72"	24"	116	\$799
FHENCPCS.24487224R	1.25"	24"	48"	72"	24"	116	\$799
FHENCPCS.24487824L	1.25"	24"	48"	78"	24"	121	\$970
FHENCPCS.24487824R	1.25"	24"	48"	78"	24"	121	\$970
FHENCPCS.24488424L	1.25"	24"	48"	84"	24"	127	\$974
FHENCPCS.24488424R	1.25"	24"	48"	84"	24"	127	\$974

**24" D CONNECTING SIDE  
30" D EXTENSION  
36" D**

PART #	HEIGHT	A	B	C	D	WT. (LBS)	LIST
FHENCPCS.24366030L	1.25"	24"	36"	60"	30"	94	\$620
FHENCPCS.24366030R	1.25"	24"	36"	60"	30"	94	\$620
FHENCPCS.24366630L	1.25"	24"	36"	66"	30"	102	\$681
FHENCPCS.24366630R	1.25"	24"	36"	66"	30"	102	\$681
FHENCPCS.24367230L	1.25"	24"	36"	72"	30"	109	\$695
FHENCPCS.24367230R	1.25"	24"	36"	72"	30"	109	\$695
FHENCPCS.24367830L	1.25"	24"	36"	78"	30"	116	\$807
FHENCPCS.24367830R	1.25"	24"	36"	78"	30"	116	\$807
FHENCPCS.24368430L	1.25"	24"	36"	84"	30"	123	\$823
FHENCPCS.24368430R	1.25"	24"	36"	84"	30"	123	\$823

**24" D CONNECTING SIDE  
30" D EXTENSION  
42" D**

PART #	HEIGHT	A	B	C	D	WT. (LBS)	LIST
FHENCPCS.24426030L	1.25"	24"	42"	60"	30"	102	\$704
FHENCPCS.24426030R	1.25"	24"	42"	60"	30"	102	\$704
FHENCPCS.24426630L	1.25"	24"	42"	66"	30"	110	\$781
FHENCPCS.24426630R	1.25"	24"	42"	66"	30"	110	\$781
FHENCPCS.24427230L	1.25"	24"	42"	72"	30"	117	\$795
FHENCPCS.24427230R	1.25"	24"	42"	72"	30"	117	\$795
FHENCPCS.24427830L	1.25"	24"	42"	78"	30"	124	\$966
FHENCPCS.24427830R	1.25"	24"	42"	78"	30"	124	\$966
FHENCPCS.24428430L	1.25"	24"	42"	84"	30"	131	\$970
FHENCPCS.24428430R	1.25"	24"	42"	84"	30"	131	\$970

**24" D CONNECTING SIDE  
30" D EXTENSION  
48" D**

PART #	HEIGHT	A	B	C	D	WT. (LBS)	LIST
FHENCPCS.24486030L	1.25"	24"	48"	60"	30"	111	\$708
FHENCPCS.24486030R	1.25"	24"	48"	60"	30"	111	\$708
FHENCPCS.24486630L	1.25"	24"	48"	66"	30"	119	\$785
FHENCPCS.24486630R	1.25"	24"	48"	66"	30"	119	\$785
FHENCPCS.24487230L	1.25"	24"	48"	72"	30"	126	\$799
FHENCPCS.24487230R	1.25"	24"	48"	72"	30"	126	\$799
FHENCPCS.24487830L	1.25"	24"	48"	78"	30"	133	\$970
FHENCPCS.24487830R	1.25"	24"	48"	78"	30"	133	\$970
FHENCPCS.24488430L	1.25"	24"	48"	84"	30"	140	\$974
FHENCPCS.24488430R	1.25"	24"	48"	84"	30"	140	\$974

**30" D CONNECTING SIDE  
30" D EXTENSION  
36" D**

PART #	HEIGHT	A	B	C	D	WT. (LBS)	LIST
FHENCPCS.30366030L	1.25"	30"	36"	60"	30"	95	\$662
FHENCPCS.30366030R	1.25"	30"	36"	60"	30"	95	\$662
FHENCPCS.30366630L	1.25"	30"	36"	66"	30"	103	\$723
FHENCPCS.30366630R	1.25"	30"	36"	66"	30"	103	\$723
FHENCPCS.30367230L	1.25"	30"	36"	72"	30"	110	\$738
FHENCPCS.30367230R	1.25"	30"	36"	72"	30"	110	\$738
FHENCPCS.30367830L	1.25"	30"	36"	78"	30"	118	\$849
FHENCPCS.30367830R	1.25"	30"	36"	78"	30"	118	\$849
FHENCPCS.30368430L	1.25"	30"	36"	84"	30"	125	\$866
FHENCPCS.30368430R	1.25"	30"	36"	84"	30"	125	\$866

**30" D CONNECTING SIDE  
30" D EXTENSION  
42" D**

PART #	HEIGHT	A	B	C	D	WT. (LBS)	LIST
FHENCPCS.30426030L	1.25"	30"	42"	60"	30"	106	\$747
FHENCPCS.30426030R	1.25"	30"	42"	60"	30"	106	\$747
FHENCPCS.30426630L	1.25"	30"	42"	66"	30"	114	\$824
FHENCPCS.30426630R	1.25"	30"	42"	66"	30"	114	\$824
FHENCPCS.30427230L	1.25"	30"	42"	72"	30"	121	\$838
FHENCPCS.30427230R	1.25"	30"	42"	72"	30"	121	\$838
FHENCPCS.30427830L	1.25"	30"	42"	78"	30"	128	\$981
FHENCPCS.30427830R	1.25"	30"	42"	78"	30"	128	\$981
FHENCPCS.30428430L	1.25"	30"	42"	84"	30"	135	\$998
FHENCPCS.30428430R	1.25"	30"	42"	84"	30"	135	\$998

**90° Extended Notched Corner Peninsula / continued**

**30" D CONNECTING SIDE**  
**30" D EXTENSION**  
**48" D**

PART #	HEIGHT	A	B	C	D	WT. (LBS)	LIST
FHENCPCS.30486030L	1.25"	30"	48"	60"	30"	116	\$751
FHENCPCS.30486030R	1.25"	30"	48"	60"	30"	116	\$751
FHENCPCS.30486630L	1.25"	30"	48"	66"	30"	124	\$828
FHENCPCS.30486630R	1.25"	30"	48"	66"	30"	124	\$828
FHENCPCS.30487230L	1.25"	30"	48"	72"	30"	131	\$842
FHENCPCS.30487230R	1.25"	30"	48"	72"	30"	131	\$842
FHENCPCS.30487830L	1.25"	30"	48"	78"	30"	138	\$985
FHENCPCS.30487830R	1.25"	30"	48"	78"	30"	138	\$985
FHENCPCS.30488430L	1.25"	30"	48"	84"	30"	144	\$1,002
FHENCPCS.30488430R	1.25"	30"	48"	84"	30"	144	\$1,002



## Extended Curved Corner Peninsula Worksurface

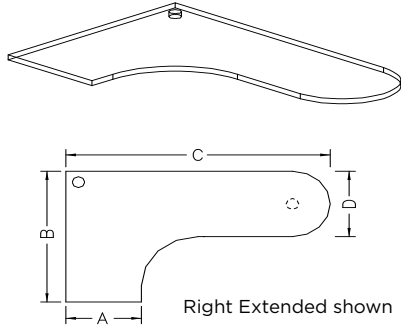

### DESCRIPTION

Worksurface hangs from a panel or wall strips. It has a laminate top and a PVC edge. There is a 1" gap at the back of the worksurface for plug and cord passage.

### SPECIFICATION OPTIONS

**product #:** see charts below  
**worksurface finish:** see page 6  
**edge finish:** see page 6  
**support finish:** DT Dark Tone, MT Medium Tone, CW Cloud White  
**left or right extended:** L for Left, R for Right

### NOTES

- Includes one wire grommet, cantilever brackets, one corner bracket, and attachment hardware
- Specify L for left extended, and R for right extended
- Includes one support column leg
- Column leg finish matches support

### ORDER EXAMPLE

**product #:** FHECCPWS.24366024L  
**worksurface finish:** M1 Light Maple  
**edge finish:** M1 Light Maple  
**support finish:** E9 Cloud White  
**left or right extended:** L

### 24" D CONNECTING SIDE 24" D EXTENSION 36" D

PART #	HEIGHT	A	B	C	D	WT. (LBS)	LIST
FHECCPWS.24366024L	1.25"	24"	36"	60"	24"	87	\$620
FHECCPWS.24366024R	1.25"	24"	36"	60"	24"	87	\$620
FHECCPWS.24366624L	1.25"	24"	36"	66"	24"	93	\$681
FHECCPWS.24366624R	1.25"	24"	36"	66"	24"	93	\$681
FHECCPWS.24367224L	1.25"	24"	36"	72"	24"	99	\$695
FHECCPWS.24367224R	1.25"	24"	36"	72"	24"	99	\$695
FHECCPWS.24367824L	1.25"	24"	36"	78"	24"	105	\$807
FHECCPWS.24367824R	1.25"	24"	36"	78"	24"	105	\$807
FHECCPWS.24368424L	1.25"	24"	36"	84"	24"	110	\$823
FHECCPWS.24368424R	1.25"	24"	36"	84"	24"	110	\$823

### 24" D CONNECTING SIDE 24" D EXTENSION 42" D

PART #	HEIGHT	A	B	C	D	WT. (LBS)	LIST
FHECCPWS.24426024L	1.25"	24"	42"	60"	24"	94	\$704
FHECCPWS.24426024R	1.25"	24"	42"	60"	24"	94	\$704
FHECCPWS.24426624L	1.25"	24"	42"	66"	24"	100	\$781
FHECCPWS.24426624R	1.25"	24"	42"	66"	24"	100	\$781
FHECCPWS.24427224L	1.25"	24"	42"	72"	24"	106	\$795
FHECCPWS.24427224R	1.25"	24"	42"	72"	24"	106	\$795
FHECCPWS.24427824L	1.25"	24"	42"	78"	24"	111	\$966
FHECCPWS.24427824R	1.25"	24"	42"	78"	24"	111	\$966
FHECCPWS.24428424L	1.25"	24"	42"	84"	24"	116	\$970
FHECCPWS.24428424R	1.25"	24"	42"	84"	24"	116	\$970

## Extended Curved Corner Peninsula / continued

**24" D CONNECTING SIDE  
24" D EXTENSION  
48" D**

PART #	HEIGHT	A	B	C	D	WT. (LBS)	LIST
FHECCPWS.24486024L	1.25"	24"	48"	60"	24"	101	\$708
FHECCPWS.24486024R	1.25"	24"	48"	60"	24"	101	\$708
FHECCPWS.24486624L	1.25"	24"	48"	66"	24"	107	\$785
FHECCPWS.24486624R	1.25"	24"	48"	66"	24"	107	\$785
FHECCPWS.24487224L	1.25"	24"	48"	72"	24"	112	\$799
FHECCPWS.24487224R	1.25"	24"	48"	72"	24"	112	\$799
FHECCPWS.24487824L	1.25"	24"	48"	78"	24"	118	\$970
FHECCPWS.24487824R	1.25"	24"	48"	78"	24"	118	\$970
FHECCPWS.24488424L	1.25"	24"	48"	84"	24"	124	\$974
FHECCPWS.24488424R	1.25"	24"	48"	84"	24"	124	\$974

**24" D CONNECTING SIDE  
30" D EXTENSION  
36" D**

PART #	HEIGHT	A	B	C	D	WT. (LBS)	LIST
FHECCPWS.24366030L	1.25"	24"	36"	60"	30"	94	\$620
FHECCPWS.24366030R	1.25"	24"	36"	60"	30"	94	\$620
FHECCPWS.24366630L	1.25"	24"	36"	66"	30"	101	\$681
FHECCPWS.24366630R	1.25"	24"	36"	66"	30"	101	\$681
FHECCPWS.24367230L	1.25"	24"	36"	72"	30"	108	\$695
FHECCPWS.24367230R	1.25"	24"	36"	72"	30"	108	\$695
FHECCPWS.24367830L	1.25"	24"	36"	78"	30"	115	\$807
FHECCPWS.24367830R	1.25"	24"	36"	78"	30"	115	\$807
FHECCPWS.24368430L	1.25"	24"	36"	84"	30"	123	\$823
FHECCPWS.24368430R	1.25"	24"	36"	84"	30"	123	\$823

**24" D CONNECTING SIDE  
30" D EXTENSION  
42" D**

PART #	HEIGHT	A	B	C	D	WT. (LBS)	LIST
FHECCPWS.24426030L	1.25"	24"	42"	60"	30"	100	\$704
FHECCPWS.24426030R	1.25"	24"	42"	60"	30"	100	\$704
FHECCPWS.24426630L	1.25"	24"	42"	66"	30"	107	\$781
FHECCPWS.24426630R	1.25"	24"	42"	66"	30"	107	\$781
FHECCPWS.24427230L	1.25"	24"	42"	72"	30"	113	\$795
FHECCPWS.24427230R	1.25"	24"	42"	72"	30"	113	\$795
FHECCPWS.24427830L	1.25"	24"	42"	78"	30"	120	\$966
FHECCPWS.24427830R	1.25"	24"	42"	78"	30"	120	\$966
FHECCPWS.24428430L	1.25"	24"	42"	84"	30"	126	\$970
FHECCPWS.24428430R	1.25"	24"	42"	84"	30"	126	\$970

**24" D CONNECTING SIDE  
30" D EXTENSION  
48" D**

PART #	HEIGHT	A	B	C	D	WT. (LBS)	LIST
FHECCPWS.24486030L	1.25"	24"	48"	60"	30"	107	\$708
FHECCPWS.24486030R	1.25"	24"	48"	60"	30"	107	\$708
FHECCPWS.24486630L	1.25"	24"	48"	66"	30"	113	\$785
FHECCPWS.24486630R	1.25"	24"	48"	66"	30"	113	\$785
FHECCPWS.24487230L	1.25"	24"	48"	72"	30"	118	\$799
FHECCPWS.24487230R	1.25"	24"	48"	72"	30"	118	\$799
FHECCPWS.24487830L	1.25"	24"	48"	78"	30"	124	\$970
FHECCPWS.24487830R	1.25"	24"	48"	78"	30"	124	\$970
FHECCPWS.24488430L	1.25"	24"	48"	84"	30"	129	\$974
FHECCPWS.24488430R	1.25"	24"	48"	84"	30"	129	\$974

**30" D CONNECTING SIDE  
30" D EXTENSION  
36" D**

PART #	HEIGHT	A	B	C	D	WT. (LBS)	LIST
FHECCPWS.30366030L	1.25"	30"	36"	60"	30"	95	\$662
FHECCPWS.30366030R	1.25"	30"	36"	60"	30"	95	\$662
FHECCPWS.30366630L	1.25"	30"	36"	66"	30"	103	\$723
FHECCPWS.30366630R	1.25"	30"	36"	66"	30"	103	\$723
FHECCPWS.30367230L	1.25"	30"	36"	72"	30"	110	\$738
FHECCPWS.30367230R	1.25"	30"	36"	72"	30"	110	\$738
FHECCPWS.30367830L	1.25"	30"	36"	78"	30"	117	\$849
FHECCPWS.30367830R	1.25"	30"	36"	78"	30"	117	\$849
FHECCPWS.30368430L	1.25"	30"	36"	84"	30"	124	\$866
FHECCPWS.30368430R	1.25"	30"	36"	84"	30"	124	\$866

**30" D CONNECTING SIDE  
30" D EXTENSION  
42" D**

PART #	HEIGHT	A	B	C	D	WT. (LBS)	LIST
FHECCPWS.30426030L	1.25"	30"	42"	60"	30"	101	\$747
FHECCPWS.30426030R	1.25"	30"	42"	60"	30"	101	\$747
FHECCPWS.30426630L	1.25"	30"	42"	66"	30"	108	\$824
FHECCPWS.30426630R	1.25"	30"	42"	66"	30"	108	\$824
FHECCPWS.30427230L	1.25"	30"	42"	72"	30"	114	\$838
FHECCPWS.30427230R	1.25"	30"	42"	72"	30"	114	\$838
FHECCPWS.30427830L	1.25"	30"	42"	78"	30"	120	\$981
FHECCPWS.30427830R	1.25"	30"	42"	78"	30"	120	\$981
FHECCPWS.30428430L	1.25"	30"	42"	84"	30"	127	\$998
FHECCPWS.30428430R	1.25"	30"	42"	84"	30"	127	\$998

**Extended Curved Corner Peninsula / continued**

**30" D CONNECTING SIDE**  
**30" D EXTENSION**  
**48" D**

PART #	HEIGHT	A	B	C	D	WT. (LBS)	LIST
FHECCPWS.30486030L	1.25"	30"	48"	60"	30"	107	\$751
FHECCPWS.30486030R	1.25"	30"	48"	60"	30"	107	\$751
FHECCPWS.30486630L	1.25"	30"	48"	66"	30"	113	\$828
FHECCPWS.30486630R	1.25"	30"	48"	66"	30"	113	\$828
FHECCPWS.30487230L	1.25"	30"	48"	72"	30"	118	\$842
FHECCPWS.30487230R	1.25"	30"	48"	72"	30"	118	\$842
FHECCPWS.30487830L	1.25"	30"	48"	78"	30"	124	\$985
FHECCPWS.30487830R	1.25"	30"	48"	78"	30"	124	\$985
FHECCPWS.30488430L	1.25"	30"	48"	84"	30"	129	\$1,002
FHECCPWS.30488430R	1.25"	30"	48"	84"	30"	129	\$1,002

## Extended Curved Corner P-Shape Peninsula Worksurface

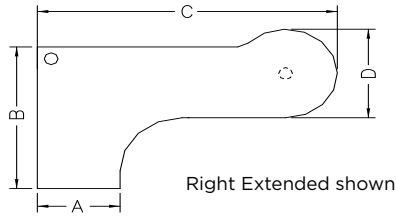
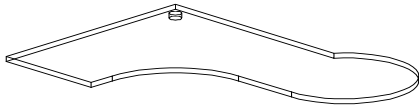

### DESCRIPTION

Worksurface hangs from a panel or wall strips. It has a laminate top and a PVC edge. There is a 1" gap at the back of the worksurface for plug and cord passage.

### SPECIFICATION OPTIONS

**product #:** see charts below  
**worksurface finish:** see page 6  
**edge finish:** see page 6  
**support finish:** DT Dark Tone, MT Medium Tone, CW Cloud White  
**left or right extended:** L for Left, R for Right

### NOTES

- Includes one wire grommet, cantilever brackets, one corner bracket, and attachment hardware
- Specify L for left extended, and R for right extended
- Includes one support column leg
- Column leg finish matches support

### ORDER EXAMPLE

**product #:** FHECCPPWS.24426024L  
**worksurface finish:** M1 Light Maple  
**edge finish:** M1 Light Maple  
**support finish:** E9 Cloud White  
**left or right extended:** L

### 24" D CONNECTING SIDES 42" D

PART #	HEIGHT	A	B	C	D	WT. (LBS)	LIST
FHECCPPWS.24426024L	1.25"	24"	42"	60"	36"	105	\$761
FHECCPPWS.24426024R	1.25"	24"	42"	60"	36"	105	\$761
FHECCPPWS.24426624L	1.25"	24"	42"	66"	36"	112	\$842
FHECCPPWS.24426624R	1.25"	24"	42"	66"	36"	112	\$842
FHECCPPWS.24427224L	1.25"	24"	42"	72"	36"	119	\$860
FHECCPPWS.24427224R	1.25"	24"	42"	72"	36"	119	\$860
FHECCPPWS.24427824L	1.25"	24"	42"	78"	36"	126	\$1,009
FHECCPPWS.24427824R	1.25"	24"	42"	78"	36"	126	\$1,009
FHECCPPWS.24428424L	1.25"	24"	42"	84"	36"	134	\$1,031
FHECCPPWS.24428424R	1.25"	24"	42"	84"	36"	134	\$1,031

### 24" D CONNECTING SIDES 48" D

PART #	HEIGHT	A	B	C	D	WT. (LBS)	LIST
FHECCPPWS.24486024L	1.25"	24"	48"	60"	36"	113	\$845
FHECCPPWS.24486024R	1.25"	24"	48"	60"	36"	113	\$845
FHECCPPWS.24486624L	1.25"	24"	48"	66"	36"	120	\$942
FHECCPPWS.24486624R	1.25"	24"	48"	66"	36"	120	\$942
FHECCPPWS.24487224L	1.25"	24"	48"	72"	36"	127	\$960
FHECCPPWS.24487224R	1.25"	24"	48"	72"	36"	127	\$960
FHECCPPWS.24487824L	1.25"	24"	48"	78"	36"	134	\$1,141
FHECCPPWS.24487824R	1.25"	24"	48"	78"	36"	134	\$1,141
FHECCPPWS.24488424L	1.25"	24"	48"	84"	36"	141	\$1,164
FHECCPPWS.24488424R	1.25"	24"	48"	84"	36"	141	\$1,164

## Extended Curved Corner P-Shape Peninsula / continued

<b>30" D CONNECTING SIDES 42" D</b>	PART #	HEIGHT	A	B	C	D	WT. (LBS)	LIST
	FHECCPPWS.30426030L	1.25"	30"	42"	60"	36"	109	\$803
	FHECCPPWS.30426030R	1.25"	30"	42"	60"	36"	109	\$803
	FHECCPPWS.30426630L	1.25"	30"	42"	66"	36"	116	\$884
	FHECCPPWS.30426630R	1.25"	30"	42"	66"	36"	116	\$884
	FHECCPPWS.30427230L	1.25"	30"	42"	72"	36"	123	\$902
	FHECCPPWS.30427230R	1.25"	30"	42"	72"	36"	123	\$902
	FHECCPPWS.30427830L	1.25"	30"	42"	78"	36"	131	\$1,051
	FHECCPPWS.30427830R	1.25"	30"	42"	78"	36"	131	\$1,051
	FHECCPPWS.30428430L	1.25"	30"	42"	84"	36"	138	\$1,074
	FHECCPPWS.30428430R	1.25"	30"	42"	84"	36"	138	\$1,074

<b>30" D CONNECTING SIDES 48" D</b>	PART #	HEIGHT	A	B	C	D	WT. (LBS)	LIST
	FHECCPPWS.30486030L	1.25"	30"	48"	60"	36"	116	\$887
	FHECCPPWS.30486030R	1.25"	30"	48"	60"	36"	116	\$887
	FHECCPPWS.30486630L	1.25"	30"	48"	66"	36"	123	\$984
	FHECCPPWS.30486630R	1.25"	30"	48"	66"	36"	123	\$984
	FHECCPPWS.30487230L	1.25"	30"	48"	72"	36"	132	\$1,003
	FHECCPPWS.30487230R	1.25"	30"	48"	72"	36"	132	\$1,003
	FHECCPPWS.30487830L	1.25"	30"	48"	78"	36"	139	\$1,183
	FHECCPPWS.30487830R	1.25"	30"	48"	78"	36"	139	\$1,183
	FHECCPPWS.30488430L	1.25"	30"	48"	84"	36"	146	\$1,206
	FHECCPPWS.30488430R	1.25"	30"	48"	84"	36"	146	\$1,206

## Ellipse End Peninsula

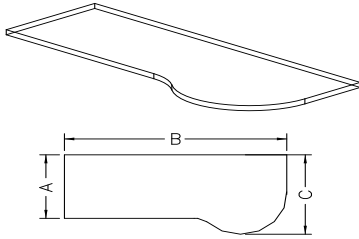

Right Extended shown

### DESCRIPTION

Worksurface hangs from a panel or wall strips. It has a laminate top and a PVC edge. There is a 1" gap at the back of the worksurface for plug and cord passage. 60" to 84" worksurfaces have center support.

### NOTES

- Includes cantilever brackets and attachment hardware

### SPECIFICATION OPTIONS

**product #:** see charts below  
**worksurface finish:** see page 6  
**edge finish:** see page 6  
**support finish:** DT Dark Tone, MT Medium Tone, CW Cloud White

### ORDER EXAMPLE

**product #:** FHEEPWS.246030  
**worksurface finish:** M1 Light Maple  
**edge finish:** E1 Light Maple  
**support finish:** E9 Cloud White

### 24" D LEFT 30" D RIGHT

PART #	HEIGHT	A	B	C	D	WT. (LBS)	LIST
FHEEPWS.246030	1.25"	24"	60"	30"	—	52	\$490
FHEEPWS.246630	1.25"	24"	66"	30"	—	59	\$542
FHEEPWS.247230	1.25"	24"	72"	30"	—	66	\$555
FHEEPWS.247830	1.25"	24"	78"	30"	—	74	\$649
FHEEPWS.248430	1.25"	24"	84"	30"	—	81	\$664

### 30" D LEFT 24" D RIGHT

PART #	HEIGHT	A	B	C	D	WT. (LBS)	LIST
FHEEPWS.306024	1.25"	30"	60"	24"	—	52	\$490
FHEEPWS.306624	1.25"	30"	66"	24"	—	59	\$542
FHEEPWS.307224	1.25"	30"	72"	24"	—	66	\$555
FHEEPWS.307824	1.25"	30"	78"	24"	—	74	\$649
FHEEPWS.308424	1.25"	30"	84"	24"	—	81	\$664

### 30" D LEFT 36" D RIGHT

PART #	HEIGHT	A	B	C	D	WT. (LBS)	LIST
FHEEPWS.306036	1.25"	30"	60"	36"	—	57	\$572
FHEEPWS.306636	1.25"	30"	66"	36"	—	64	\$632
FHEEPWS.307236	1.25"	30"	72"	36"	—	71	\$645
FHEEPWS.307836	1.25"	30"	78"	36"	—	79	\$756
FHEEPWS.308436	1.25"	30"	84"	36"	—	86	\$771

### 36" D LEFT 30" D RIGHT

PART #	HEIGHT	A	B	C	D	WT. (LBS)	LIST
FHEEPWS.366030	1.25"	36"	60"	30"	—	57	\$572
FHEEPWS.366630	1.25"	36"	66"	30"	—	64	\$632
FHEEPWS.367230	1.25"	36"	72"	30"	—	71	\$645
FHEEPWS.367830	1.25"	36"	78"	30"	—	79	\$756
FHEEPWS.368430	1.25"	36"	84"	30"	—	86	\$771

## Rectangular Asymmetrical

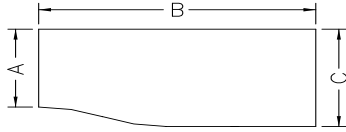
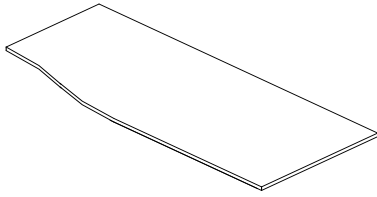

Right Extended shown

### DESCRIPTION

Worksurface hangs from a panel or wall strips. It has a laminate top and a PVC edge. There is a 1" gap at the back of the worksurface for plug and cord passage. 60" to 84" worksurfaces have center support.

### NOTES

- Includes cantilever brackets and attachment hardware
- 78"W and 84"W worksurfaces will accept a 42"W or 36"W lateral file
- 72"W worksurface will accept a 36"W lateral file
- 66"W worksurface will accept a 30"W lateral file
- Worksurfaces shorter than 48"W will not accept a pedestal

### SPECIFICATION OPTIONS

**product #:** see charts below  
**worksurface finish:** see page 6  
**edge finish:** see page 6  
**support finish:** DT Dark Tone, MT Medium Tone, CW Cloud White

### ORDER EXAMPLE

**product #:** FHRWWS.243030  
**worksurface finish:** M1 Light Maple  
**edge finish:** M1 Light Maple  
**support finish:** E9 Cloud White

### 24" D LEFT 30" D RIGHT

PART #	HEIGHT	A	B	C	D	WT. (LBS)	LIST
FHRWWS.243030	1.25"	24"	30"	30"	—	40	\$246
FHRWWS.243630	1.25"	24"	36"	30"	—	46	\$281
FHRWWS.244230	1.25"	24"	42"	30"	—	53	\$287
FHRWWS.244830	1.25"	24"	48"	30"	—	60	\$344
FHRWWS.245430	1.25"	24"	54"	30"	—	66	\$350
FHRWWS.246030	1.25"	24"	60"	30"	—	74	\$416
FHRWWS.246630	1.25"	24"	66"	30"	—	81	\$423
FHRWWS.247230	1.25"	24"	72"	30"	—	88	\$469
FHRWWS.247830	1.25"	24"	78"	30"	—	95	\$556
FHRWWS.248430	1.25"	24"	84"	30"	—	102	\$560

### 30" D LEFT 24" D RIGHT

PART #	HEIGHT	A	B	C	D	WT. (LBS)	LIST
FHRWWS.303024	1.25"	30"	30"	24"	—	40	\$246
FHRWWS.303624	1.25"	30"	36"	24"	—	46	\$281
FHRWWS.304224	1.25"	30"	42"	24"	—	53	\$287
FHRWWS.304824	1.25"	30"	48"	24"	—	60	\$344
FHRWWS.305424	1.25"	30"	54"	24"	—	66	\$350
FHRWWS.306024	1.25"	30"	60"	24"	—	74	\$416
FHRWWS.306624	1.25"	30"	66"	24"	—	81	\$423
FHRWWS.307224	1.25"	30"	72"	24"	—	88	\$469
FHRWWS.307824	1.25"	30"	78"	24"	—	95	\$556
FHRWWS.308424	1.25"	30"	84"	24"	—	102	\$560



# 120° Rectangular

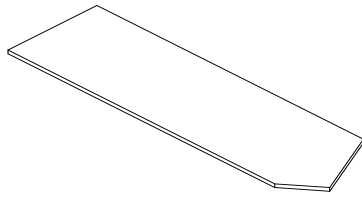

Right End shown

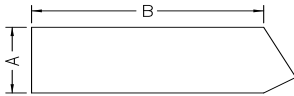

### DESCRIPTION

Worksurface hangs from a panel and has a 120° end, either left or right. It has a PVC edge. There is a 1" gap at the back of the worksurface for plug and cord passage.

### SPECIFICATION OPTIONS

**product #:** see charts below  
**worksurface finish:** see page 6  
**edge finish:** see page 6  
**support finish:** DT Dark Tone, MT Medium Tone, CW Cloud White  
**left or right extended:** L for Left, R for Right

### NOTES

- Includes cantilever brackets and attachment hardware
- 78"W and 84"W worksurfaces will accept a 42"W or 36"W lateral file
- 72"W worksurface will accept a 36"W lateral file
- 66"W worksurface will accept a 30"W lateral file
- Worksurfaces shorter than 48"W will not accept a pedestal

### ORDER EXAMPLE

**product #:** FH12OWS.2424L  
**worksurface finish:** M1 Light Maple  
**edge finish:** M1 Light Maple  
**support finish:** E9 Cloud White  
**left or right extended:** L

## 120° RECTANGULAR

PART #	HEIGHT	A	B	C	D	WT. (LBS)	LIST
FH12OWS.2424L	1.25"	24"	24"	—	—	33	\$309
FH12OWS.2424R	1.25"	24"	24"	—	—	33	\$309
FH12OWS.2430L	1.25"	24"	30"	—	—	40	\$333
FH12OWS.2430R	1.25"	24"	30"	—	—	40	\$333
FH12OWS.2436L	1.25"	24"	36"	—	—	45	\$358
FH12OWS.2436R	1.25"	24"	36"	—	—	45	\$358
FH12OWS.2442L	1.25"	24"	42"	—	—	52	\$400
FH12OWS.2442R	1.25"	24"	42"	—	—	52	\$400
FH12OWS.2448L	1.25"	24"	48"	—	—	57	\$409
FH12OWS.2448R	1.25"	24"	48"	—	—	57	\$409
FH12OWS.2460L	1.25"	24"	60"	—	—	64	\$475
FH12OWS.2460R	1.25"	24"	60"	—	—	64	\$475

## 120° Corner / 90° Ends

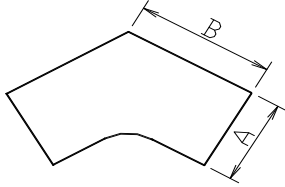

### DESCRIPTION

Worksurface hangs from a panel. It has a laminate top and a PVC edge. There is a 1" gap at the back of the worksurface for plug and cord passage. Worksurface is 24" deep.

### NOTES

- Includes cantilever brackets, corner bracket, and attachment hardware

### SPECIFICATION OPTIONS

**product #:** see charts below  
**worksurface finish:** see page 6  
**edge finish:** see page 6  
**support finish:** DT Dark Tone, MT Medium Tone, CW Cloud White

### ORDER EXAMPLE

**product #:** FH120/90WS.2424  
**worksurface finish:** M1 Light Maple  
**edge finish:** M1 Light Maple  
**support finish:** E9 Cloud White

### 120° CORNER 90° ENDS

PART #	HEIGHT	A	B	C	D	WT. (LBS)	LIST
FH120/90WS.2424	1.25"	24"	24"	—	—	30	\$390
FH120/90WS.2430	1.25"	24"	30"	—	—	41	\$440
FH120/90WS.2436	1.25"	24"	36"	—	—	50	\$538
FH120/90WS.2442	1.25"	24"	42"	—	—	62	\$644
FH120/90WS.2448	1.25"	24"	48"	—	—	80	\$783

## 120° Corner / 120° Ends

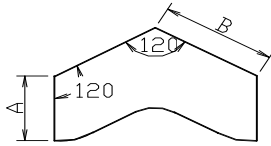
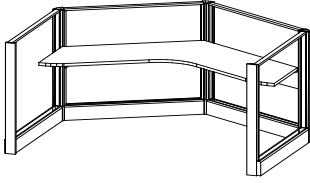

### DESCRIPTION

Worksurface hangs from a panel. It has a laminate top and a PVC edge. There is a 1" gap at the back of the worksurface for plug and cord passage. Worksurface is 24" deep.

### NOTES

- Includes cantilever brackets, corner bracket, and attachment hardware

### SPECIFICATION OPTIONS

**product #:** see charts below  
**worksurface finish:** see page 6  
**edge finish:** see page 6  
**support finish:** DT Dark Tone, MT Medium Tone, CW Cloud White

### ORDER EXAMPLE

**product #:** FH120/90WS.2424  
**worksurface finish:** M1 Light Maple  
**edge finish:** M1 Light Maple  
**support finish:** E9 Cloud White

### 120° CORNER 120° ENDS

PART #	HEIGHT	A	B	C	D	WT. (LBS)	LIST
FH120/120WS.2436	1.25"	24"	36"	—	—	—	\$544
FH120/120WS.2442	1.25"	24"	42"	—	—	—	\$651
FH120/120WS.2448	1.25"	24"	48"	—	—	—	\$791

## 135° Corner

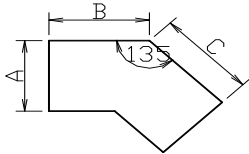
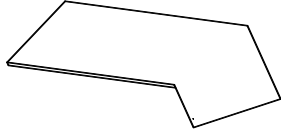
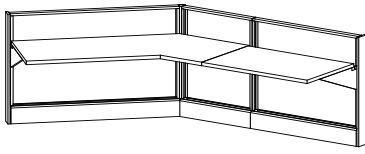

### DESCRIPTION

Worksurface hangs from a panel. It has a laminate top and a PVC edge. There is a 1" gap at the back of the worksurface for plug and cord passage. Worksurface is 24" deep.

### NOTES

- Includes cantilever brackets, corner bracket, and attachment hardware

### SPECIFICATION OPTIONS

**product #:** see charts below  
**worksurface finish:** see page 6  
**edge finish:** see page 6  
**support finish:** DT Dark Tone, MT Medium Tone, CW Cloud White

### ORDER EXAMPLE

**product #:** FH120/90WS.2424  
**worksurface finish:** M1 Light Maple  
**edge finish:** M1 Light Maple  
**support finish:** E9 Cloud White  
 t

## 135° CORNER WORKSURFACE

PART #	HEIGHT	A	B	C	D	WT. (LBS)	LIST
FH135CWS24.2424	1.25"	24"	24"	—	—	—	\$486
FH135CWS24.3030	1.25"	30"	30"	—	—	—	\$564
FH135CWS24.4824	1.25"	48"	24"	—	—	—	\$546
FH135CWS24.2448	1.25"	24"	48"	—	—	—	\$648

PART #	HEIGHT	A	B	C	D	WT. (LBS)	LIST
FH135CWS30.2424	1.25"	24"	24"	—	—	—	\$515
FH135CWS30.3030	1.25"	30"	30"	—	—	—	\$594
FH135CWS30.4824	1.25"	48"	24"	—	—	—	\$663
FH135CWS30.2448	1.25"	24"	48"	—	—	—	\$670

# 135° Double Corner

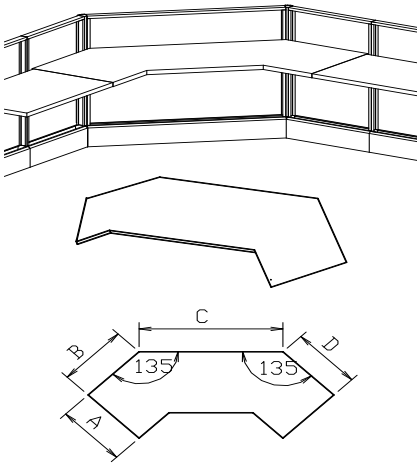

## DESCRIPTION

Worksurface hangs from a panel. It has a laminate top and a PVC edge. There is a 1" gap at the back of the worksurface for plug and cord passage. Worksurface is 24" deep.

## SPECIFICATION OPTIONS

**product #:** see charts below  
**worksurface finish:** see page 6  
**edge finish:** see page 6  
**support finish:** DT Dark Tone, MT Medium Tone, CW Cloud White

## NOTES

- Includes cantilever brackets, corner bracket, and attachment hardware

## ORDER EXAMPLE

**product #:** FH120/90WS.2424  
**worksurface finish:** M1 Light Maple  
**edge finish:** M1 Light Maple  
**support finish:** E9 Cloud White

## 135° DOUBLE CORNER WORKSURFACE

PART #	HEIGHT	A	B	C	D	WT. (LBS)	LIST
FH135DCWS24.244824	1.25"	24"	24"	48"	24"	—	\$925
FH135DCWS30.244824	1.25"	30"	24"	48"	24"	—	\$929

## Transaction Surface

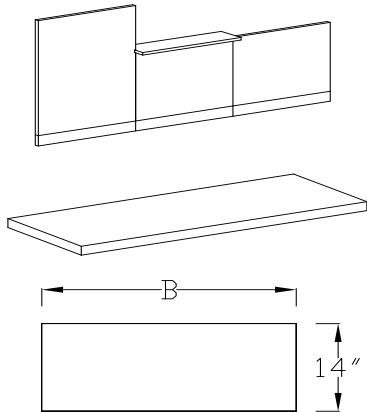

### DESCRIPTION

14"D Rectangular transaction worksurface attaches to the top of a panel. Ends are flush with the panel. It has a PVC edge.

### NOTES

- Attaches to the top of a panel for counter or display area.
- Includes transaction brackets and attachment hardware.

### SPECIFICATION OPTIONS

**product #:** see charts below  
**worksurface finish:** see page 6  
**edge finish:** see page 6  
**support finish:** DT Dark Tone, MT Medium Tone, CW Cloud White

### ORDER EXAMPLE

**product #:** FHERTS.1424LC  
**worksurface finish:** M1 Light Maple  
**edge finish:** M1 Light Maple  
**support finish:** E9 Cloud White

### TRANSACTION SURFACE

PART #	HEIGHT	A	B	C	D	WT. (LBS)	LIST
FHERTS.1424L	1.25"	14"	24"	—	—	17	\$133
FHERTS.1430L	1.25"	14"	30"	—	—	21	\$153
FHERTS.1436L	1.25"	14"	36"	—	—	24	\$166
FHERTS.1442L	1.25"	14"	42"	—	—	27	\$198
FHERTS.1448L	1.25"	14"	48"	—	—	31	\$202
FHERTS.1460L	1.25"	14"	60"	—	—	38	\$234
FHERTS.1472L	1.25"	14"	72"	—	—	43	\$266

### TRANSACTION SURFACE AT CHANGE OF HEIGHT

PART #	HEIGHT	A	B	C	D	WT. (LBS)	LIST
FHERTS.1424LC	1.25"	14"	23.5"	—	—	17	\$133
FHERTS.1430LC	1.25"	14"	29.5"	—	—	21	\$153
FHERTS.1436LC	1.25"	14"	35.5"	—	—	24	\$166
FHERTS.1442LC	1.25"	14"	41.5"	—	—	27	\$198
FHERTS.1448LC	1.25"	14"	47.5"	—	—	31	\$202
FHERTS.1460LC	1.25"	14"	59.5"	—	—	38	\$234
FHERTS.1472LC	1.25"	14"	71.5"	—	—	43	\$266

## Corner Transaction

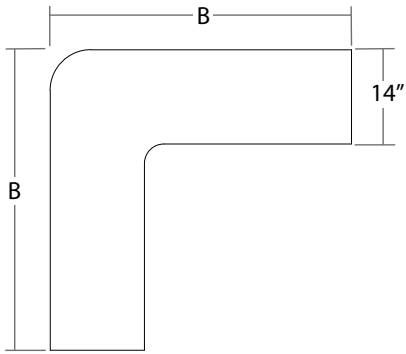

### DESCRIPTION

14"D Transaction worksurface attaches to the top of two panels. Ends are flush with the panels. It has a PVC edge.

### NOTES

- Attaches to the top of two 24", 30", 36", 42" or 48"W.
- Panels connected at a 90° angle for corner counter or display area
- Includes transaction brackets and attachment hardware.

### SPECIFICATION OPTIONS

**product #:** see charts below  
**worksurface finish:** see page 6  
**edge finish:** see page 6  
**support finish:** DT Dark Tone, MT Medium Tone, CW Cloud White

### ORDER EXAMPLE

**product #:** FHECTS.24  
**worksurface finish:** M1 Light Maple  
**edge finish:** M1 Light Maple  
**support finish:** E9 Cloud White

### CORNER TRANSACTION

PART #	HEIGHT	A	B	C	D	WT. (LBS)	LIST
FHECTS.24	1.25"	14"	32"	—	—	40	\$254
FHECTS.30	1.25"	14"	38"	—	—	48	\$338
FHECTS.36	1.25"	14"	44"	—	—	55	\$374
FHECTS.42	1.25"	14"	50"	—	—	62	\$526
FHECTS.48	1.25"	14"	56"	—	—	71	\$530

## Rectangular Worksurfaces For Use w/ MY-HITE Base

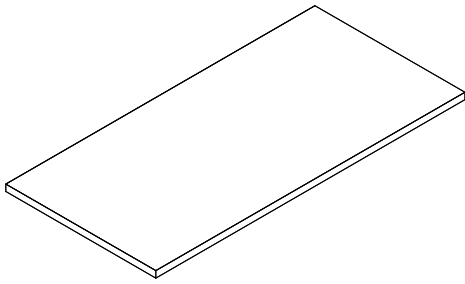

**DESCRIPTION**

Worksurface top only, for use with height adjustable base within workstation application

**NOTES**

- Add circular grommet (add \$75 list) Specify GL, GC, GR
- Order base separately from MY-HITE pricebook

Note: Top size reduced 1" in depth and 2" in width to fit within system workstation and prevent pinch points. See system pricebook for details. We do not recommend using full size worktop in paneled workstation applications.

**SPECIFICATION OPTIONS**

**product #:** see charts below  
**top, edge finish:** worksurface finish:  
 see page 6

**ORDER EXAMPLE**

**product #:** FHRWS.2364  
**edge finish:** M1 Light Maple  
**worksurface finish:** E9 Cloud White  
**grommet:** GC (Rear Center)

### SQUARE EDGE RECTANGULAR WORKSURFACE

PART #	DEPTH	WIDTH	PRICE
FHRWS.2340	23"	40"	\$247
FHRWS.2346	23"	46"	\$252
FHRWS.2352	23"	52"	\$289
FHRWS.2358	23"	58"	\$315
FHRWS.2364	23"	64"	\$351
FHRWS.2370	23"	70"	\$360
FHRWS.2376	23"	76"	\$444
FHRWS.2940	29"	40"	\$317
FHRWS.2946	29"	46"	\$325
FHRWS.2952	29"	52"	\$368
FHRWS.2958	29"	58"	\$394
FHRWS.2964	29"	64"	\$440
FHRWS.2970	29"	70"	\$449
FHRWS.2976	29"	76"	\$552

**NOTES**

Sizes are actual for example  
 FHRWS.2364 is 23" x 64"



## Corner Worksurfaces For Use w/ MY-HITE Bases

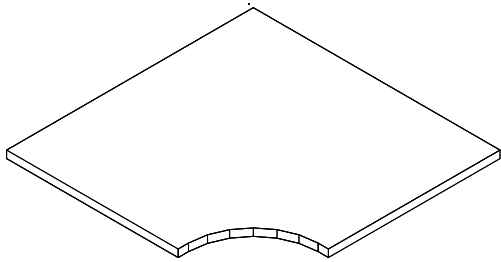

DESCRIPTION

Corner worksurface top only, for use with height adjustable base within workstation application.

NOTES

- Add circular grommet (add \$75 list) Specify GL, GC, GR
- Order base separately from MY-HITE pricebook

Note: Top size reduced 1" in depth and 2" in width to fit within system workstation and prevent pinch points. See system pricebook for details. We do not recommend using full size worktop in paneled workstation applications.

SPECIFICATION OPTIONS

**product #:** see charts below  
**top, edge finish:** worksurface finish:  
 see page 6

ORDER EXAMPLE

**product #:** FHCWS.2942  
**edge finish:** M1 Light Maple  
**worksurface finish:** E9 Cloud White  
**grommet:** GC (Rear Center)

**SQUARE EDGE CORNER WORKSURFACE**

PART #	WIDTH	DEPTH	PRICE
FHCWS.2340	40"	23"	\$404
FHCWS.2346	46"	23"	\$427
FHCWS.2940	42"	29"	\$439
FHCWS.2946	48"	29"	\$462

NOTES

Sizes are actual for example  
 FHCWS.2942 is 29" x 42"

## 90° Extended Curved Corner Worksurface For Use w/ MY-HITE Bases

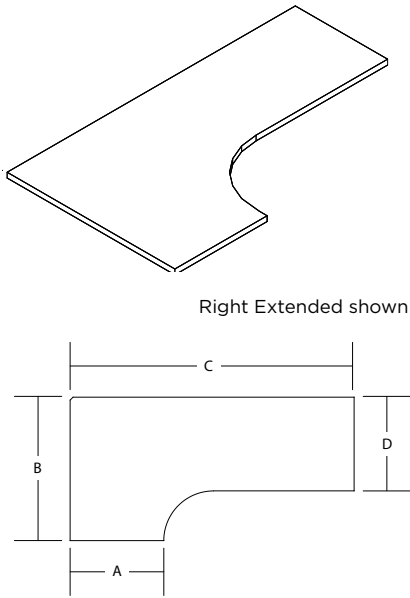

**DESCRIPTION**

Laminate worksurface with 3mm PVC edge

**SPECIFICATION OPTIONS**

**product #:** see charts below  
**top, edge, worksurface finish:** see page 6  
**left or right extended:** L for Left, R for Right

**NOTES**

- Worksurface top only, for use with height adjustable base within workstation application
- See My-Hite pricebook for use inside a freestanding application
- Add circular grommet (add \$75 list) Specify grommet placement GL, GC, GR
- Top size reduced 1" in depth and 2" in width to fit within system workstation and prevent pinch points.
- We do not recommend using full size worktop in paneled workstation applications
- Base covers are metal

**ORDER EXAMPLE**

**product #:** FHECCWS.23345823L  
**top, edge finish:** E10 Espresso  
**worksurface finish:** M11 Light Walnut

**23" D CONNECTING SIDE  
 23" D EXTENSION  
 34" D**

PART #	HEIGHT	A	B	C	D	PRICE
FHECCWS.23345823L	1.25"	23"	34"	58"	23"	\$475
FHECCWS.23345823R	1.25"	23"	34"	58"	23"	\$475
FHECCWS.23346423L	1.25"	23"	34"	64"	23"	\$529
FHECCWS.23346423R	1.25"	23"	34"	64"	23"	\$529
FHECCWS.23347023L	1.25"	23"	34"	70"	23"	\$538
FHECCWS.23347023R	1.25"	23"	34"	70"	23"	\$538
FHECCWS.23347623L	1.25"	23"	34"	76"	23"	\$645
FHECCWS.23347623R	1.25"	23"	34"	76"	23"	\$645

**29" D CONNECTING SIDE  
 29" D EXTENSION  
 34" D**

PART #	HEIGHT	A	B	C	D	PRICE
FHECCWS.29345829L	1.25"	29"	34"	58"	29"	\$520
FHECCWS.29345829R	1.25"	29"	34"	58"	29"	\$520
FHECCWS.29346429L	1.25"	29"	34"	64"	29"	\$573
FHECCWS.29346429R	1.25"	29"	34"	64"	29"	\$573
FHECCWS.29347029L	1.25"	29"	34"	70"	29"	\$582
FHECCWS.29347029R	1.25"	29"	34"	70"	29"	\$582
FHECCWS.29347629L	1.25"	29"	34"	76"	29"	\$689
FHECCWS.29347629R	1.25"	29"	34"	76"	29"	\$689

**23" D CONNECTING SIDE  
23" D EXTENSION  
40" D**

PART #	HEIGHT	A	B	C	D	PRICE
FHECCWS.23405823L	1.25"	23"	40"	58"	23"	\$571
FHECCWS.23405823R	1.25"	23"	40"	58"	23"	\$571
FHECCWS.23406423L	1.25"	23"	40"	64"	23"	\$643
FHECCWS.23406423R	1.25"	23"	40"	64"	23"	\$643
FHECCWS.23407023L	1.25"	23"	40"	70"	23"	\$652
FHECCWS.23407023R	1.25"	23"	40"	70"	23"	\$652
FHECCWS.23407623L	1.25"	23"	40"	76"	23"	\$791
FHECCWS.23407623R	1.25"	23"	40"	76"	23"	\$791

**29" D CONNECTING SIDE  
29" D EXTENSION  
40" D**

PART #	HEIGHT	A	B	C	D	PRICE
FHECCWS.29405829	1.25"	29"	40"	58"	29"	\$615
FHECCWS.29405829	1.25"	29"	40"	58"	29"	\$615
FHECCWS.29406429	1.25"	29"	40"	64"	29"	\$687
FHECCWS.29406429	1.25"	29"	40"	64"	29"	\$687
FHECCWS.29407029	1.25"	29"	40"	70"	29"	\$696
FHECCWS.29407029	1.25"	29"	40"	70"	29"	\$696
FHECCWS.29407629	1.25"	29"	40"	76"	29"	\$835
FHECCWS.29407629	1.25"	29"	40"	76"	29"	\$835

**23" D CONNECTING SIDE  
23" D EXTENSION  
46" D**

PART #	HEIGHT	A	B	C	D	PRICE
FHECCWS.23465823L	1.25"	23"	46"	58"	23"	\$580
FHECCWS.23465823R	1.25"	23"	46"	58"	23"	\$580
FHECCWS.23466423L	1.25"	23"	46"	64"	23"	\$652
FHECCWS.23466423R	1.25"	23"	46"	64"	23"	\$652
FHECCWS.23467023L	1.25"	23"	46"	70"	23"	\$667
FHECCWS.23467023R	1.25"	23"	46"	70"	23"	\$667
FHECCWS.23467623L	1.25"	23"	46"	76"	23"	\$813
FHECCWS.23467623R	1.25"	23"	46"	76"	23"	\$813

**29" D CONNECTING SIDE  
29" D EXTENSION  
46" D**

PART #	HEIGHT	A	B	C	D	PRICE
FHECCWS.29465829L	1.25"	29"	46"	58"	29"	\$625
FHECCWS.29465829R	1.25"	29"	46"	58"	29"	\$625
FHECCWS.29466429L	1.25"	29"	46"	64"	29"	\$696
FHECCWS.29466429R	1.25"	29"	46"	64"	29"	\$696
FHECCWS.29467029L	1.25"	29"	46"	70"	29"	\$712
FHECCWS.29467029R	1.25"	29"	46"	70"	29"	\$712
FHECCWS.29467629L	1.25"	29"	46"	76"	29"	\$857
FHECCWS.29467629R	1.25"	29"	46"	76"	29"	\$857

## D-Shaped | Worksurface For Use w/ MY-HITE Bases

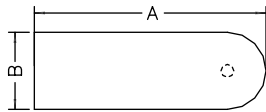
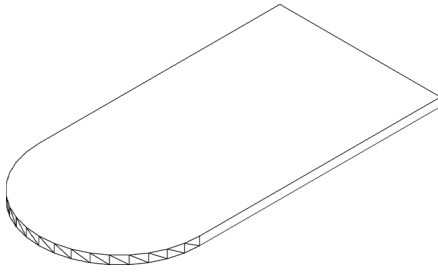

### DESCRIPTION

Worksurface top only, for use with height adjustable base within workstation application

### NOTES

- Add grommet (add \$75 list)  
Specify GL, GC, GR
- Order base separately from MY-HITE pricebook

Note: Top size reduced 1" in depth and 2" in width to fit within system workstation and prevent pinch points. We do not recommend using full size worktop in paneled workstation applications.

### SPECIFICATION OPTIONS

**product #:** see charts below  
**top, edge finish:** worksurface finish:  
see page 6

### ORDER EXAMPLE

**product #:** FHEDSP.2346  
**edge finish:** DT Dark Tone, E12  
**worksurface finish:** Espresso, M10  
**grommet:** GC (Rear Center)

### SQUARE EDGE D-SHAPED

PART #	HEIGHT	A	B	C	D	PRICE
FHEDSP.2346	1.25"	46"	23"	—	—	\$369
FHEDSP.2358	1.25"	58"	23"	—	—	\$413
FHEDSP.2946	1.25"	46"	29"	—	—	\$405
FHEDSP.2958	1.25"	58"	29"	—	—	\$448
FHEDSP.2970	1.25"	70"	29"	—	—	\$491
FHEDSP.3570	1.25"	70"	35"	—	—	\$542

## Wedge | Worksurface For Use w/ MY-HITE Bases

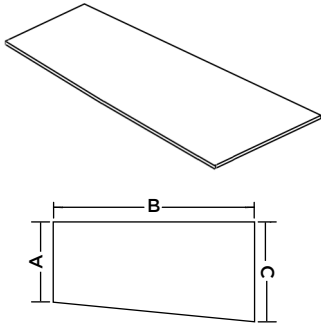

### DESCRIPTION

Worksurface top only, for use with height adjustable base within workstation application

### NOTES

- Add grommet (add \$75 list)  
Specify GL, GC, GR
- Order base separately from MY-HITE pricebook

Note: Top size reduced 1" in depth and 2" in width to fit within system workstation and prevent pinch points. We do not recommend using full size worktop in paneled workstation applications.

### SPECIFICATION OPTIONS

**product #:** see charts below  
**top, edge finish:** worksurface finish:  
See page 6

### ORDER EXAMPLE

**product #:** FHWDWS.234029  
**edge finish:** DT Dark Tone, E12  
**worksurface finish:** Espresso, M10  
**grommet:** GC (Rear Center)

### 23"D LEFT 29"D RIGHT

PART #	HEIGHT	A	B	C	D	PRICE
FHWDWS.234029	1.25"	23"	40"	29"	—	\$328
FHWDWS.234629	1.25"	23"	46"	29"	—	\$335
FHWDWS.235229	1.25"	23"	52"	29"	—	\$380
FHWDWS.235829	1.25"	23"	58"	29"	—	\$407
FHWDWS.236429	1.25"	23"	64"	29"	—	\$454
FHWDWS.237029	1.25"	23"	70"	29"	—	\$464
FHWDWS.237629	1.25"	23"	76"	29"	—	\$540

### 29"D LEFT 23"D RIGHT

PART #	HEIGHT	A	B	C	D	PRICE
FHWDWS.294023	1.25"	29"	40"	23"	—	\$328
FHWDWS.294623	1.25"	29"	46"	23"	—	\$335
FHWDWS.295223	1.25"	29"	52"	23"	—	\$380
FHWDWS.295823	1.25"	29"	58"	23"	—	\$407
FHWDWS.296423	1.25"	29"	64"	23"	—	\$454
FHWDWS.297023	1.25"	29"	70"	23"	—	\$464
FHWDWS.297623	1.25"	29"	76"	23"	—	\$540

## 120° Corner / 90° Ends Worksurface For Use w/ MY-HITE Bases

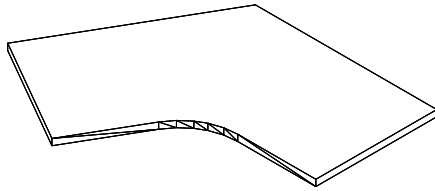

### DESCRIPTION

Worksurface top only, for use with height adjustable base within workstation application

### NOTES

- Add grommet (add \$75 list) Specify GL, GC, GR
- Order base separately from MY-HITE pricebook

Note: Top size reduced 1" in depth and 2" in width to fit within system workstation and prevent pinch points. We do not recommend using full size worktop in paneled workstation applications.

### SPECIFICATION OPTIONS

**product #:** see charts below  
**top, edge finish:** worksurface finish:  
 See page 6

### ORDER EXAMPLE

**product #:** FH120-90WS.2436  
**edge finish:** DT Dark Tone, E12  
**worksurface finish:** Espresso, M10  
**grommet:** GC (Rear Center)

### 120° CORNER 90° ENDS

PART #	HEIGHT	A	B	C	D	PRICE
FH120-90WS.2334	1.25"	23"	34"	—	—	\$565
FH120-90WS.2340	1.25"	23"	40"	—	—	\$676
FH120-90WS.2346	1.25"	23"	46"	—	—	\$822

## 120° Corner / 120° Ends Worksurface For Use w/ MY-HITE Bases

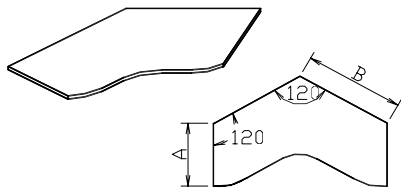

### DESCRIPTION

Worksurface top only, for use with height adjustable base within workstation application

### NOTES

- Add grommet (add \$75 list) Specify GL, GC, GR
- Order base separately from MY-HITE pricebook

Note: Top size reduced 1" in depth and 2" in width to fit within system workstation and prevent pinch points. We do not recommend using full size worktop in paneled workstation applications.

### SPECIFICATION OPTIONS

**product #:** see charts below  
**top, edge finish:** worksurface finish:  
 see page 6

### ORDER EXAMPLE

**product #:** FH120-120WS.2436  
**edge finish:** DT Dark Tone, E12  
**worksurface finish:** Espresso, M10  
**grommet:** GC (Rear Center)

### 120° CORNER 120° ENDS

PART #	HEIGHT	A	B	C	D	PRICE
FH120-120WS.2334	1.25"	23"	34"	—	—	\$571
FH120-120WS.2340	1.25"	23"	40"	—	—	\$684
FH120-120WS.2346	1.25"	23"	46"	—	—	\$831

## Grommets

### DESCRIPTION

3" plastic grommet for use with worksurfaces.

### NOTES

- All worksurfaces, except corner worksurfaces, do not include grommets.
- Corner worksurface include grommet (in corner)

### SPECIFICATION OPTIONS

**product #:** see charts below

### ORDER EXAMPLE

**product #:** FIG.BU (Black Umber finish)

## GROMMET

PART #	HEIGHT	WIDTH	DEPTH	WT. (LBS)	PRICE	NOTES
FIG.BU (Black Umber)	-	-	-	-	\$2	Grommet color included with worksurface is standard.
FIG.CW (Cloud White)	-	-	-	-	\$2	Order separately for other color.

WORKSURFACE FINISH	STANDARD GROMMET COLOR
Light Maple	CW grommets
Light Cherry	BU grommets
Medium Cherry	BU grommets
Mahogany	BU grommets
Light Mahogany	BU grommets
Light Gray	CW grommets
White	CW grommets
Gray Specks	CW grommets
Cloud White	CW grommets
Espresso	BU grommets



## Flat Bracket

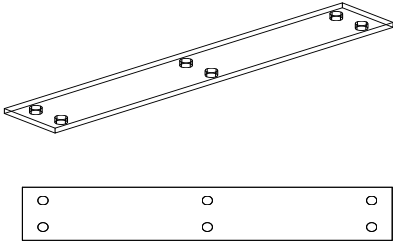

### DESCRIPTION

This flat bracket is used to support two worksurfaces when a support leg or panel leg is inappropriate.

### NOTES

### SPECIFICATION OPTIONS

**product #:** see charts below

### ORDER EXAMPLE

**product #:** FHFB.18

### FLAT BRACKET

PART #	HEIGHT	A	B	C	D	WT. (LBS)	LIST
FHFB.18	3"	18"	—	—	—	1	\$36

## Mending Plates

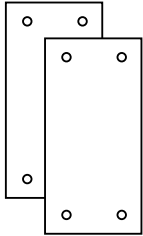

### DESCRIPTION

This Mending Plate is to be ordered if you're placing corner workstations next to other corner workstations without a rectangular worksurface return. Mending plate size is 2" x 4"

### NOTES

- Sold in pairs

### SPECIFICATION OPTIONS

**product #:** see charts below

### ORDER EXAMPLE

**product #:** FASS22-0-ZN

### MENDING PLATES

PART #	HEIGHT	A	B	C	D	WT. (LBS)	PRICE
FASS22-0-ZN	—	—	—	—	—	1	\$4

## Supports

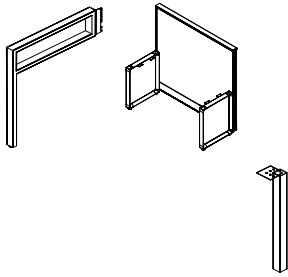

### DESCRIPTION

Provides support to the worksurface.

### SPECIFICATION OPTIONS

**product #:** see charts below  
**support finish:** DT Dark Tone, MT Medium Tone, CW Cloud White

### NOTES

- Use with frame and wall strip worksurfaces

### ORDER EXAMPLE

**product #:** FHTMLD.24  
**support finish:** CW Cloud White

## SQUARE POST LEG



PART #	HEIGHT	WIDTH	DEPTH	WT. (LBS)	LIST
FHSPL.2	27.5"	2"	2"	.25	\$79
FHSPL.3	27.5"	3"	3"	.25	\$111

### NOTES

Attaches to the underside of a worksurface and has an adjustable glide.

Specify finish: DT, MT, CW

## CORNER BRACKET

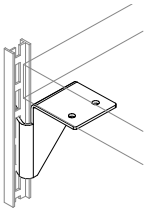

Right Handed shown

PART #	HEIGHT	WIDTH	DEPTH	WT. (LBS)	LIST
FHWSB.L	2.75"	—	2.5"	.25	\$11
FHWSB.R	2.75"	—	2.5"	.25	\$11

### NOTES

Attaches to the front corner of a hanging worksurface to provide additional support when the return panel matches the worksurface depth.

Also used as support for the back corner of a corner worksurface.

Specify left or right.

Color: Black

## SUPPORT END PANEL

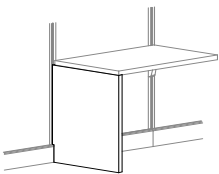

PART #	HEIGHT	WIDTH	DEPTH	WT. (LBS)	LIST
FWSSEP.24-MEL	27.75"	1.25"	24"	26	\$289
FWSSEP.30-MEL	27.75"	1.25"	30"	32	\$323

### NOTES

Attaches to a worksurface and a frame or wall strip.

Finishes: DT, MT, CW

## Supports continued

### SQUARE METAL P LEG SINGLE SUPPORT

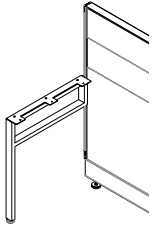

PART #	HEIGHT	WIDTH	DEPTH	WT. (LBS)	LIST
FHSMLS.24	27.5"	1.25"	24"	17	\$126
FHSMLS.30	27.5"	1.25"	30"	20	\$143

#### NOTES

This support attaches to a worksurface and a frame or wall strip. It provides support for a single worksurface.

To convert from left handed to right handed, remove attachment brackets, and reinstall in the position needed.

Specify the depth of the worksurface support to match the depth of the worksurface.

Specify finish: DT, MT, CW

### SQUARE METAL P LEG DOUBLE SUPPORT

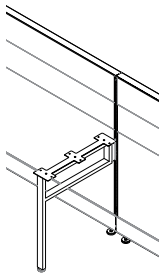

PART #	HEIGHT	WIDTH	DEPTH	WT. (LBS)	LIST
FHSMLD.24	27.5"	1.25"	24"	17	\$139
FHSMLD.30	27.5"	1.25"	30"	20	\$158

#### NOTES

This support attaches to a worksurface and a frame or wall strip. It provides support for two worksurfaces.

Specify the depth of the worksurface support to match the depth of the worksurface.

Specify finish: DT, MT, CW

### SQUARE CORNER TRIANGLE SHAPE LEG SINGLE SUPPORT

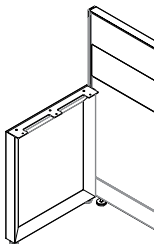

PART #	HEIGHT	WIDTH	DEPTH	WT. (LBS)	LIST
FHTMLDS.24	27.5"	1.25"	24"	26	\$153
FHTMLDS.30	27.5"	1.25"	30"	32	\$173

#### NOTES

This support leg attaches to a worksurface and a frame or wall strip. It provides support for a single worksurface.

To convert to a left or right support, remove the top bar and reinstall it in the desired position.

Specify the depth of the support leg to match the depth of the worksurface.

Includes all attachment hardware.

Specify finish: DT, MT, CW

### SQUARE CORNER TRIANGLE SHAPE LEG DOUBLE SUPPORT

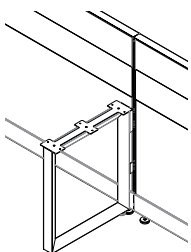

PART #	HEIGHT	WIDTH	DEPTH	WT. (LBS)	LIST
FHTMLDD.24	27.5"	1.25"	24"	26	\$164
FHTMLDD.30	27.5"	1.25"	30"	32	\$187

#### NOTES

This support leg attaches to a worksurface and a frame or wall strip. It provides support for two worksurfaces.

Specify the depth of the support leg to match the depth of the worksurface.

Includes all attachment hardware.

Specify finish: DT, MT, CW

## Supports continued

### TAPER & INSET LEGS

#### DESCRIPTION

Taper and Inset Legs for use with the Novo workstation

#### SPECIFICATION OPTIONS

**product #:** see charts below  
**finish:** CW, SV, BU

#### NOTES

- Systems angled leg

### TAPER LEGS

PART #	HEIGHT	DEPTH	LIST
FHATPL.24	27.5"	24"	\$438
FHATPL.30	27.5"	30"	\$447

#### NOTES

- Attaches to the underside of a worksurface

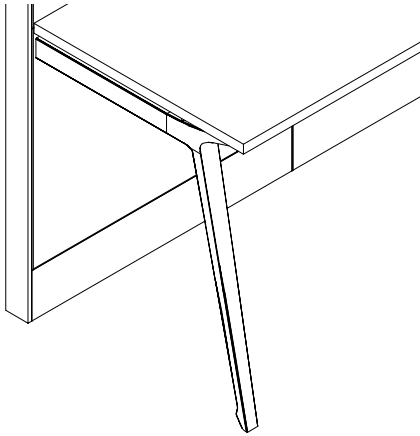

### INSET LEGS

PART #	HEIGHT	DEPTH	LIST
FHAINL.24	27.5"	24"	\$369
FHAINL.30	27.5"	30"	\$378

#### NOTES

- Attaches to the underside of a worksurface

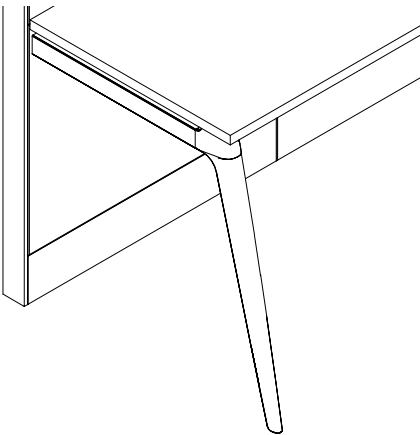

# Components

DESCRIPTION	SPECIFICATION OPTIONS
Components for the workstation.	<b>product #:</b> see charts below <b>finish:</b> DT Dark Tone, MT Medium Tone, CW Cloud White
NOTES	ORDER EXAMPLE
	<b>product #:</b> FPD <b>finish:</b> CW Cloud White

## LED TASKLIGHT



PART #	HEIGHT	WIDTH	DEPTH	WT. (LBS)	LIST	NOTES
FLED.20	0.75"	20"	1"	1	\$221	Attaches beneath a shelf or storage cabinet.
FLED.38	0.75"	38"	1"	2	\$278	It includes an LED light, motion sensor, power cord and installation hardware. Has a pivot range of +/-15°. For overheads 24"-36" use FLED.20 For overheads 42" or wider use FLED.38 Finish: Silver

## WIRE MANAGER

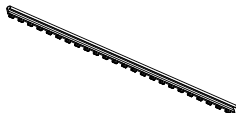

PART #	HEIGHT	WIDTH	DEPTH	WT. (LBS)	LIST	NOTES
F2WM.24	24"	.5"	—	1	\$19	This Wire Manager is used to manage electrical cords vertically. It fits between side-by-side panels, or between a panel and a connector. Finish: Black.

## PENCIL DRAWER

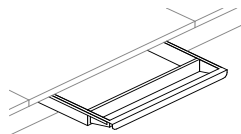

PART #	HEIGHT	WIDTH	DEPTH	WT. (LBS)	LIST	NOTES
FPD	1.875"	21.125"	16.25"	5	\$164	Stores small items. Attaches under worksurface. Includes attachment hardware. Finish: DT Dark Tone, MT Medium Tone.

## Frameless Glass Clear

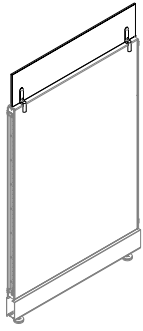

### DESCRIPTION

### SPECIFICATION OPTIONS

**product #:** see charts below

### NOTES

- Frameless Glass screens are attached to the top of a single frame with included hardware.
- Matches width of the frame.
- Package contains 2.

### ORDER EXAMPLE

**product #:** FHFG.0824-CL

### FRAMELESS GLASS 8" CLEAR

PART #	HEIGHT	WIDTH	DEPTH	WT. (LBS)	LIST	NOTES
F2FG.0824-CL	8"	23-1/4"	—	—	\$289	Includes attachment hardware, brushed finish.
F2FG.0830-CL	8"	29-1/4"	—	—	\$312	
F2FG.0836-CL	8"	35-1/4"	—	—	\$334	Package contains 2.
F2FG.0842-CL	8"	41-1/4"	—	—	\$357	
F2FG.0848-CL	8"	47-1/4"	—	—	\$380	

### FRAMELESS GLASS 14" CLEAR

PART #	HEIGHT	WIDTH	DEPTH	WT. (LBS)	LIST	NOTES
F2FG.1424-CL	14"	23-1/4"	—	—	\$357	Includes attachment hardware, brushed finish.
F2FG.1430-CL	14"	29-1/4"	—	—	\$396	
F2FG.1436-CL	14"	35-1/4"	—	—	\$433	Package contains 2.
F2FG.1442-CL	14"	41-1/4"	—	—	\$470	
F2FG.1448-CL	14"	47-1/4"	—	—	\$511	

## Frameless Glass Frosted

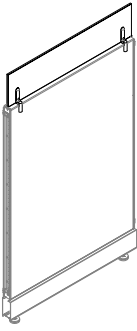

### DESCRIPTION

### SPECIFICATION OPTIONS

**product #:** see charts below

### NOTES

- Frameless Glass screens are attached to the top of a single frame with included hardware.
- Matches width of the frame.
- Package contains 2.

### ORDER EXAMPLE

**product #:** FHFG.0824-FR

### FRAMELESS GLASS 8" FROSTED

PART #	HEIGHT	WIDTH	DEPTH	WT. (LBS)	LIST	NOTES
F2FG.0824-FR	8"	23-1/4"	—	—	\$332	Includes attachment hardware, brushed finish.
F2FG.0830-FR	8"	29-1/4"	—	—	\$376	
F2FG.0836-FR	8"	35-1/4"	—	—	\$419	Package contains 2.
F2FG.0842-FR	8"	41-1/4"	—	—	\$463	
F2FG.0848-FR	8"	47-1/4"	—	—	\$506	

### FRAMELESS GLASS 14" FROSTED

PART #	HEIGHT	WIDTH	DEPTH	WT. (LBS)	LIST	NOTES
F2FG.1424-FR	14"	23-1/4"	—	—	\$463	Includes attachment hardware, brushed finish.
F2FG.1430-FR	14"	29-1/4"	—	—	\$536	
F2FG.1436-FR	14"	35-1/4"	—	—	\$609	Package contains 2.
F2FG.1442-FR	14"	41-1/4"	—	—	\$680	
F2FG.1448-FR	14"	47-1/4"	—	—	\$758	

## Privacy Screen, Fabric

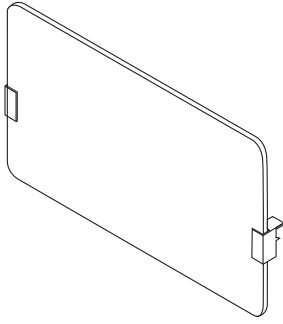

### DESCRIPTION

Work Surface mounted fabric covered privacy screen

### NOTES

Fabric screen is non-tackable

Actual screen is shorter than the worktop.

Example: FPSFLUSH.2448 for use on 46"/48" width table, actual width of screen is 40"

### SPECIFICATION OPTIONS

**product #:** see charts below

**Paint (Brackets):** CW, BU, SV

**fabric:** see page 4

### ORDER EXAMPLE

**product #:** FPSFLUSH.2442

**brackets:** SV, Silver

**fabric:** PF-701-01, Terrian, Cloud

### Fabric Privacy Screen - Flush

PART #	HEIGHT	WIDTH	LIST
FPSFLUSH.2442	24"	34"	\$457
FPSFLUSH.2448	24"	40"	\$495
FPSFLUSH.2454	24"	46"	\$533
FPSFLUSH.2460	24"	52"	\$572
FPSFLUSH.2466	24"	58"	\$611
FPSFLUSH.2472	24"	64"	\$650

### NOTES

- Privacy screen sits flush with the back of the worktop.
- Privacy screen is 8" shorter than free standing top width and 6" shorter than a worksurface from a paneled system.

Example:

1. Actual width of FPSFLUSH.2460 is 52"

### Fabric Privacy Screen - with Wire Management Gap

PART #	HEIGHT	WIDTH	LIST
FPSGAP.2442	24"	34"	\$457
FPSGAP.2448	24"	40"	\$495
FPSGAP.2454	24"	46"	\$533
FPSGAP.2460	24"	52"	\$572
FPSGAP.2466	24"	58"	\$611
FPSGAP.2472	24"	64"	\$650

### NOTES

- With 1" gap at back of worksurface for cord/wire management.

Example:

1. Actual width of FPSGAP.2460 is 52"



## Privacy Screen, Marker Board

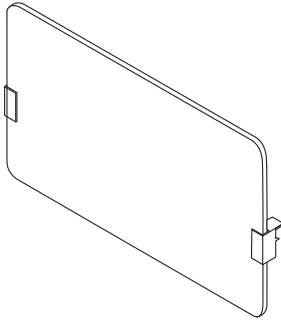

### DESCRIPTION

Work Surface mounted marker board privacy screen

### NOTES

To use a wire manager on your My-Hite table with a **marker board** privacy screen, you must order "with gap".

Actual screen is shorter than the worktop.

Example: FMPSFLUSH.2448 for use on 46"/48" width table, actual width of screen is 40"

### SPECIFICATION OPTIONS

**product #:** see charts below  
**Paint (Brackets):** CW, BU, SV  
**w**

### ORDER EXAMPLE

**product #:** FMPSFLUSH.2442  
**brackets:** SV, Silver  
**fabric:** M15 Mousse

### Marker Board Privacy Screen - Flush

PART #	HEIGHT	WIDTH	LIST
FMPSFLUSH.2442	24"	34"	\$621
FMPSFLUSH.2448	24"	40"	\$711
FMPSFLUSH.2454	24"	46"	\$801
FMPSFLUSH.2460	24"	52"	\$892
FMPSFLUSH.2466	24"	58"	\$982
FMPSFLUSH.2472	24"	64"	\$1,073

### NOTES

- Privacy screen sits flush with the back of the worktop.
- Privacy screen is 8" shorter than free standing top width and 6" shorter than a worksurface from a paneled system.

Example:

1. Actual width of FMPSFLUSH.2460 is 52"

### Marker Board Privacy Screen - with Wire Management Gap

PART #	HEIGHT	WIDTH	LIST
FMPSGAP.2442	24"	34"	\$621
FMPSGAP.2448	24"	40"	\$711
FMPSGAP.2454	24"	46"	\$801
FMPSGAP.2460	24"	52"	\$892
FMPSGAP.2466	24"	58"	\$982
FMPSGAP.2472	24"	64"	\$1,073

### NOTES

- With 1" gap at back of worksurface for cord/wire management.

Example:

1. Actual width of FMPSGAP.2460 is 52"

## Privacy Screen, Laminate

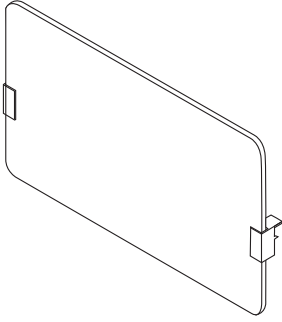

### DESCRIPTION

Work Surface mounted laminate privacy screen

### NOTES

To use a wire manager on your My-Hite table with a laminate privacy screen, you must order "with gap".

Actual screen is shorter than the worktop.

Example: FPSFLUSH.2448 for use on 46"/48" width table, actual width of screen is 40"

### SPECIFICATION OPTIONS

**product #:** see charts below  
**Paint (Brackets):** CW, BU, SV  
**finish:** see page 6

### ORDER EXAMPLE

**product #:** FLPSFLUSH.2442  
**brackets:** SV, Silver  
**fabric:** M15 Mousse

### Laminate Privacy Screen - Flush

PART #	HEIGHT	WIDTH	LIST
FLPSFLUSH.2442	24"	34"	\$372
FLPSFLUSH.2448	24"	40"	\$364
FLPSFLUSH.2454	24"	46"	\$400
FLPSFLUSH.2460	24"	52"	\$436
FLPSFLUSH.2466	24"	58"	\$473
FLPSFLUSH.2472	24"	64"	\$509

### NOTES

- Privacy screen sits flush with the back of the worktop.
- Privacy screen is 8" shorter than free standing top width and 6" shorter than a worksurface from a paneled system.

Example:

1. Actual width of FLPSFLUSH.2460 is 52"

### Laminate Privacy Screen - with Wire Management Gap

PART #	HEIGHT	WIDTH	LIST
FLPSGAP.2442	24"	34"	\$372
FLPSGAP.2448	24"	40"	\$364
FLPSGAP.2454	24"	46"	\$400
FLPSGAP.2460	24"	52"	\$436
FLPSGAP.2466	24"	58"	\$473
FLPSGAP.2472	24"	64"	\$509

### NOTES

- With 1" gap at back of worksurface for cord/wire management.

Example:

1. Actual width of FLPSGAP.2460 is 52"

## Modesty Panel, Laminate

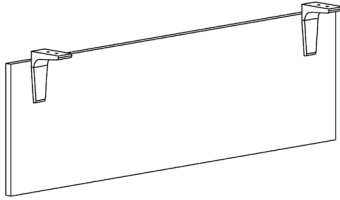

### DESCRIPTION

Laminate modesty panel with matching 2mm PVC edge

### NOTES

### SPECIFICATION OPTIONS

**product #:** see charts below  
**Paint (Brackets)** CW, BU, SV  
**Laminate (Modesty Panel)** see page 6

### ORDER EXAMPLE

**product #:** FLMOD.0836  
**paint:** CW, Cloud White  
**laminate:** M12, Medium Walnut

## Laminate Modesty Panel

PART #	HEIGHT	WIDTH	LIST	NOTES
FLMOD.0836	8"	36"	\$188	• Modesty panel is actual width
FLMOD.0842	8"	42"	\$194	
FLMOD.0848	8"	48"	\$200	
FLMOD.0854	8"	54"	\$241	
FLMOD.0860	8"	60"	\$302	
FLMOD.0866	8"	66"	\$308	
FLMOD.0872	8"	72"	\$314	
FLMOD.0884	8"	84"	\$326	
FLMOD.0896	8"	96"	\$338	
FLMOD.1636	16"	36"	\$231	
FLMOD.1642	16"	42"	\$237	
FLMOD.1648	16"	48"	\$243	
FLMOD.1654	16"	54"	\$320	
FLMOD.1660	16"	60"	\$381	
FLMOD.1666	16"	66"	\$387	
FLMOD.1672	16"	72"	\$393	
FLMOD.1684	16"	84"	\$405	
FLMOD.1696	16"	96"	\$417	

## Tackboards

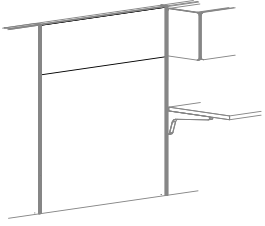

### DESCRIPTION

Fabric covered tackable surface that attaches to panel or wall strips.

### NOTES

- Includes attachment hardware.
- For "A" style components, call factory for availability

### SPECIFICATION OPTIONS

**product #:** see charts below  
**fabric:** see page 4

### ORDER EXAMPLE

**product #:** FHTAKBS.0924  
**finish:** PF301-1 Sky/Terra

### "B" STYLE TACKBOARD SQUARE CORNERS CURVED TOP & BOTTOM 8.5" HIGH

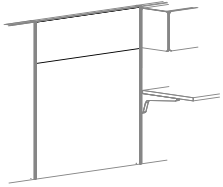

PART #	HEIGHT	WIDTH	DEPTH	WT. (LBS)	LIST
FHTAKBS.0924	8.5"	24"	—	3	\$75
FHTAKBS.0930	8.5"	30"	—	4	\$81
FHTAKBS.0936	8.5"	36"	—	4	\$91
FHTAKBS.0942	8.5"	42"	—	5	\$98
FHTAKBS.0948	8.5"	48"	—	6	\$103

### "B" STYLE TACKBOARD SQUARE CORNERS CURVED TOP & BOTTOM 15.5" HIGH

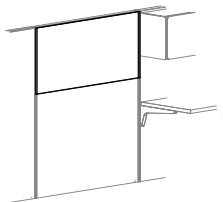

PART #	HEIGHT	WIDTH	DEPTH	WT. (LBS)	LIST
FHTAKBS.1624	15.5"	24"	—	6	\$140
FHTAKBS.1630	15.5"	30"	—	7	\$149
FHTAKBS.1636	15.5"	36"	—	9	\$156
FHTAKBS.1642	15.5"	42"	—	10	\$163
FHTAKBS.1648	15.5"	48"	—	11	\$173

# Markerboards

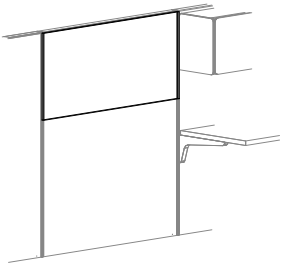

**DESCRIPTION**

Markerboards have an erasable writing surface.

**SPECIFICATION OPTIONS**

**product #:** see charts below

**NOTES**

- Marker and eraser not included

**ORDER EXAMPLE**

**product #:** F2MARBS.2424

**“B” STYLE  
MARKERBOARD  
SQUARE CORNERS  
24” HIGH**

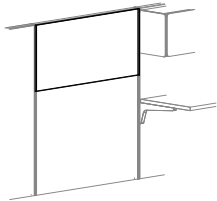

PART #	HEIGHT	WIDTH	DEPTH	WT. (LBS)	LIST
F2MARBS.2424	24"	24"	—	3	\$279
F2MARBS.2430	24"	30"	—	4	\$306
F2MARBS.2436	24"	36"	—	4	\$318
F2MARBS.2442	24"	42"	—	5	\$334
F2MARBS.2448	24"	48"	—	6	\$346
F2MARBS.2460	24"	60"	—	7	\$395

**“B” STYLE  
MARKERBOARD  
SQUARE CORNERS  
48” HIGH**

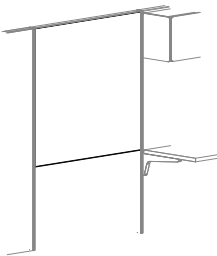

PART #	HEIGHT	WIDTH	DEPTH	WT. (LBS)	LIST
F2MARBS.4824	48"	24"	—	20	\$346
F2MARBS.4830	48"	30"	—	24	\$388
F2MARBS.4836	48"	36"	—	30	\$438
F2MARBS.4842	48"	42"	—	32	\$493
F2MARBS.4848	48"	48"	—	36	\$558
F2MARBS.4860	48"	60"	—	40	\$631

## Overheads and Shelves

DESCRIPTION	SPECIFICATION OPTIONS
Metal shelf and overhead storage.	<b>product #:</b> see charts below <b>support finish:</b> DT Dark Tone, MT Medium Tone, CW Cloud White
NOTES	ORDER EXAMPLE
<ul style="list-style-type: none"> <li>Two styles of profile available. Order to match sliding front overhead or pneumatic overhead</li> </ul>	<b>product #:</b> FHSLSH.0824 <b>support finish:</b> CW Cloud White

### STRAIGHT FRONT HALF HEIGHT SHELF

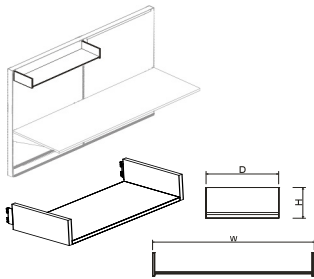

PART #	HEIGHT	WIDTH	DEPTH	WT. (LBS)	LIST	NOTES
FHSLSH.0824	7.5"	24"	12.75"	12	\$125	This shelf hangs from a frame or wall strips.
FHSLSH.0830	7.5"	30"	12.75"	13	\$132	Includes attachment hardware.
FHSLSH.0836	7.5"	36"	12.75"	13	\$146	Profile matches sliding front overhead.
FHSLSH.0842	7.5"	42"	12.75"	14	\$160	
FHSLSH.0848	7.5"	48"	12.75"	15	\$174	Specify Finish.

### SLIDING DOOR OVERHEAD CABINET

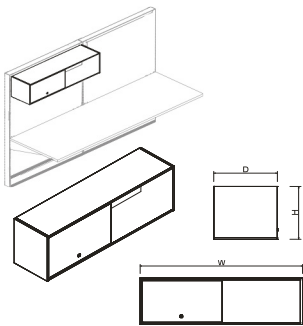

PART #	HEIGHT	WIDTH	DEPTH	WT. (LBS)	LIST	NOTES
FHSLOV.1624	15.5"	24"	12.75"	21	\$353	This lockable sliding door storage cabinet hangs from a frame or wall strips. Includes a painted sliding door front, a lock and attaching hardware.
FHSLOV.1630	15.5"	30"	12.75"	24	\$386	
FHSLOV.1636	15.5"	36"	12.75"	26	\$420	
FHSLOV.1642	15.5"	42"	12.75"	29	\$459	Lock finish: Black
FHSLOV.1648	15.5"	48"	12.75"	32	\$497	Specify Finish.

### UPMOUNT SLIDING OVERHEAD CABINET

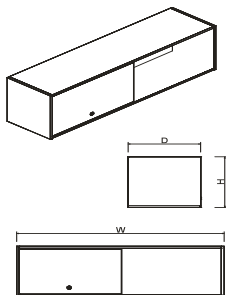

PART #	HEIGHT	WIDTH	DEPTH	WT. (LBS)	LIST	NOTES
FHSLOVU.1624	15.5"	24"	12.75"	21	\$440	This lockable sliding door storage cabinet is up-mounted on a panel.
FHSLOVU.1630	15.5"	30"	12.75"	24	\$487	
FHSLOVU.1636	15.5"	36"	12.75"	26	\$535	Includes a painted sliding door front, a lock and attaching hardware.
FHSLOVU.1642	15.5"	42"	12.75"	29	\$589	
FHSLOVU.1648	15.5"	48"	12.75"	32	\$641	Door locks on left side only.

If specifying a standard (non-LED) tasklight, specify one size smaller than the cabinet size. For example, when ordering a 42" cabinet, specify a 36" standard tasklight.

Lock Finish: Black

Specify Finish.

**RADIUS FRONT  
HALF HEIGHT SHELF**

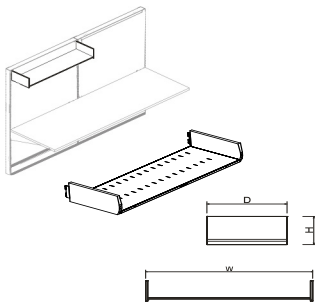

PART #	HEIGHT	WIDTH	DEPTH	WT. (LBS)	LIST
FHPHSH.0824	7.5"	24"	16"	12	\$129
FHPHSH.0830	7.5"	30"	16"	13	\$135
FHPHSH.0836	7.5"	36"	16"	13	\$150
FHPHSH.0842	7.5"	42"	16"	14	\$161
FHPHSH.0848	7.5"	48"	16"	15	\$169

**NOTES**

---

This shelf hangs from a frame or wall strips.

Includes attachment hardware.

Profile matches pneumatic overhead.

Specify Finish.

**PNEUMATIC OVERHEAD  
CABINET**

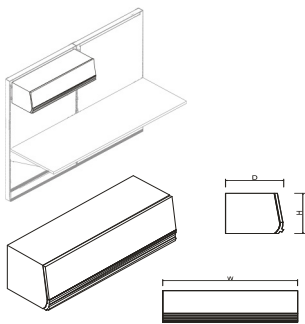

PART #	HEIGHT	WIDTH	DEPTH	WT. (LBS)	LIST
FHPNOV.1624	15.5"	24"	16"	29	\$415
FHPNOV.1630	15.5"	30"	16"	31	\$454
FHPNOV.1636	15.5"	36"	16"	33	\$492
FHPNOV.1642	15.5"	42"	16"	35	\$527
FHPNOV.1648	15.5"	48"	16"	37	\$569

**NOTES**

---

This storage cabinet, with lockable pneumatic door, hangs from a frame or wall strips.

Includes pneumatic assist flipper door, a lock, and attaching hardware.

LED tasklight only.

Lock finish: Black

Specify Finish.

**UPMOUNT PNEUMATIC  
OVERHEAD CABINET**

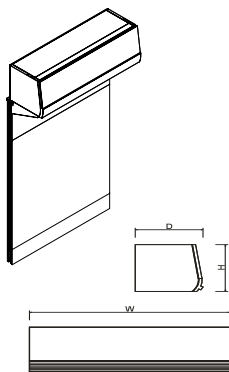

PART #	HEIGHT	WIDTH	DEPTH	WT. (LBS)	LIST
FHPNOVU.1624	15.5"	24"	16"	29	\$440
FHPNOVU.1630	15.5"	30"	16"	31	\$487
FHPNOVU.1636	15.5"	36"	16"	33	\$535
FHPNOVU.1642	15.5"	42"	16"	35	\$589
FHPNOVU.1648	15.5"	48"	16"	37	\$641

**NOTES**

---

This storage cabinet, with lockable pneumatic door, up-mounts to the top of a panel.

Includes pneumatic assist flipper door, a lock, and attaching hardware.

LED tasklight only.

Lock Finish: Black

Specify Finish.

# Pedestals

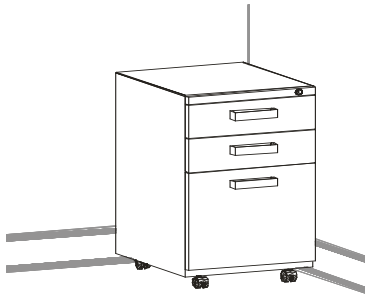

DESCRIPTION

Storage with drawers.

SPECIFICATION OPTIONS

**product #:** see charts below  
**finish:** DT Dark Tone, MT Medium Tone, CW Cloud White  
**pull:** page 8

NOTES

- Square drawer front
- Order side-to-side file bars
- Bar Pull is the default pull; to order other pulls see upcharge below
- Specify pull when ordering
- Designer Pull has color options: specify color when ordering. See page 8
- Bar Pull will be shipped in box on ALL orders, premium pulls will ship separately

ORDER EXAMPLE

**product #:** FPEDSQP.BBF-MET  
**finish:** DT  
**pull:** Wedge pull +\$75 (see upcharge below)

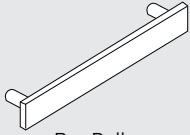
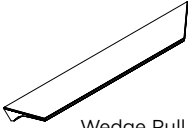
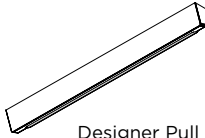
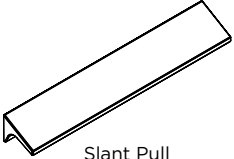
	DEFAULT PULL	PULLS REQUIRING UPCHARGE		
PEDESTAL PULL OPTIONS	 Bar Pull	 Wedge Pull	 Designer Pull • Cloud White/Red • Cloud White/Green • Cloud White/Grey	 Slant Pull

## BOX / BOX / FILE PEDESTAL

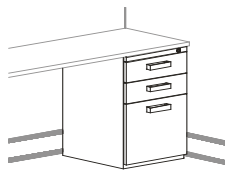

PART #	HEIGHT	WIDTH	DEPTH	WT. (LBS)	LIST
FPEDSQP.BBF-MET	27"	15"	20"	55	\$607
WEDGE, DESIGNER OR SLANT PULL					+ \$75

**NOTES**  
 Supporting metal pedestal with lock, without top cap. Attaches to the underside of a worksurface.  
 Square drawer pulls, silver color. Square drawer front.  
 Order side to side file bars.  
 Specify pull when ordering  
 Designer Pull has color options: specify color when ordering. (see page 8)

## FILE / FILE PEDESTAL

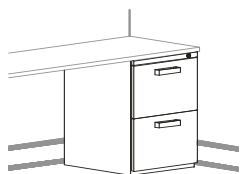

PART #	HEIGHT	WIDTH	DEPTH	WT. (LBS)	LIST
FPEDSQP.FF-MET	27"	15"	20"	53	\$607
WEDGE, DESIGNER OR SLANT PULL					+ \$50

**NOTES**  
 Supporting metal pedestal with lock, without top cap. Attaches to the underside of a worksurface.  
 Square drawer pulls, silver color. Square drawer front.  
 Order side to side file bars.  
 Specify pull when ordering  
 Designer Pull has color options: specify color when ordering. (see page 8)



**Pedestals / continued**

**BOX / FILE  
PEDESTAL MOBILE**

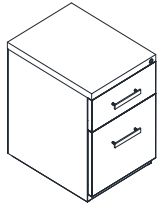

PART #	HEIGHT	WIDTH	DEPTH	WT. (LBS)	LIST
FPEDSQP.BF-MOB-MET	22"	15"	20"	85	\$665
WEDGE, DESIGNER, OR SLANT PULL					+ \$50

**NOTES**

Free-standing mobile pedestal with lock and with top cap.

Square drawer pulls, silver color. Square drawer front.

Order side to side file bars.

Specify pull when ordering

Designer Pull has color options: specify color when ordering. (see page 8)

**BOX / BOX / FILE  
PEDESTAL MOBILE**

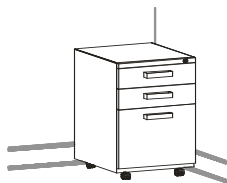

PART #	HEIGHT	WIDTH	DEPTH	WT. (LBS)	LIST
FPEDSQP.BBF-MOB-MET	27.25"	15"	20"	85	\$789
WEDGE, DESIGNER, OR SLANT PULL					+ \$75

**NOTES**

Free-standing mobile pedestal with lock and with top cap.

Square drawer pulls, silver color. Square drawer front.

Order side to side file bars.

Specify pull when ordering

Designer Pull has color options: specify color when ordering. (see page 8)

**FILE / FILE  
PEDESTAL MOBILE**

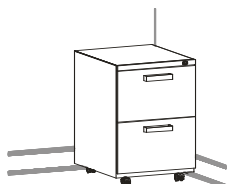

PART #	HEIGHT	WIDTH	DEPTH	WT. (LBS)	LIST
FPEDSQP.FF-MOB-MET	27.25"	15"	20"	76	\$789
WEDGE, DESIGNER, OR SLANT PULL					+ \$50

**NOTES**

Free-standing mobile pedestal with lock and with top cap.

Square drawer pulls, silver color. Square drawer front.

Order side to side file bars.

Specify pull when ordering

Designer Pull has color options: specify color when ordering. (see page 8)

## Pedestals / continued

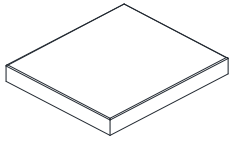
BOX / FILE PEDESTAL  
MOBILE CUSHION

PART #	HEIGHT	WIDTH	DEPTH	WT. (LBS)	LIST
FPEDSQ.CUSH	1.75"	15"	20"	—	\$272

## NOTES

For Box/File mobile pedestal only.

If cushion is placed on a full height mobile pedestal, it will not fit under a worksurface.

Passage and Terrain fabrics can not be used on mobile cushions. (See page 4)

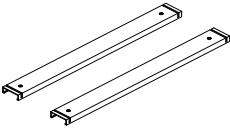
SIDE-TO-SIDE  
FILE BARS

PART #	HEIGHT	WIDTH	DEPTH	WT. (LBS)	LIST
FSSB	—	—	—	1	\$18

## NOTES

Side-to-side File Bars for filing letter or legal size folders.

Order one per file drawer.

Finish: Black.

## Lateral Files

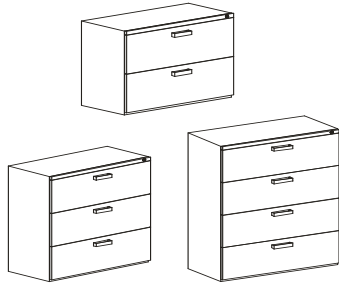

### DESCRIPTION

Storage with drawers.

### SPECIFICATION OPTIONS



**product #:** see charts below  
**finish:** DT Dark Tone, MT Medium Tone, CW Cloud White  
**pull:** page 8

### NOTES

- Freestanding 3- and 4-drawer lateral files must be bolted together or bolted to a wall
- Specify pull when ordering.
- Designer pull has color options: specify color when ordering. (See page 8)
- Bar Pull will be shipped in box on ALL orders, Premium Pulls will ship separately

### ORDER EXAMPLE

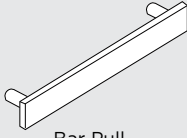
**product #:** FLFSQP-2-30-MET  
**finish:** DT  
**pull:** Designer pull - Cloud White/Red - + \$75 ( see upcharge below)

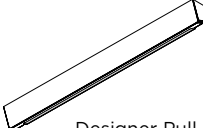
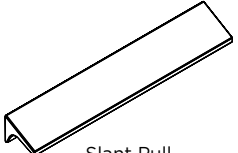
	DEFAULT PULL	PULLS REQUIRING UPCHARGE		
LATERAL FILES PULL OPTIONS	 Bar Pull	 Wedge Pull	 Designer Pull • Cloud White/Red • Cloud White/Green • Cloud White/Grey	 Slant Pull

### 2 DRAWER LATERAL FILES

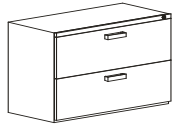

PART #	HEIGHT	WIDTH	DEPTH	WT. (LBS)	LIST	NOTES
FLFSQP-2-30-MET	27.5"	30"	20"	103	\$1,088	Supporting lateral file with lock and finished top cap.
FLFSQP-2-36-MET	27.5"	36"	20"	123	\$1,320	Square drawer pulls, silver color. Square drawer front.
FLFSQP-2-42-MET	27.5"	42"	20"	151	\$1,352	Order front to back file bars.
WEDGE, DESIGNER OR SLANT PULL					+ \$50	Order counterweight to convert to free-standing lateral file. Specify pull when ordering Designer Pull has color options: specify color when ordering. (see page 8)

### FREE-STANDING 3-DRAWER LATERAL FILES WITH TOP CAP

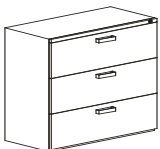

PART #	HEIGHT	WIDTH	DEPTH	WT. (LBS)	LIST	NOTES
FLFSQP-3-30-MET	40"	30"	20"	121	\$1,409	Supporting lateral file with lock and finished top cap.
FLFSQP-3-36-MET	40"	36"	20"	151	\$1,591	Square drawer pulls, silver color. Square drawer front.
FLFSQP-3-42-MET	40"	42"	20"	181	\$1,731	Order front to back file bars.
WEDGE, DESIGNER OR SLANT PULL					+ \$75	Free-standing Lateral Files must be bolted to a wall or bolted together. Specify pull when ordering. Designer Pull has color options: specify color when ordering. (see page 8)

## Lateral Files / continued

FREE-STANDING  
4-DRAWER LATERAL  
FILES WITH TOP CAP

PART #	HEIGHT	WIDTH	DEPTH	WT. (LBS)	LIST
FLFSQP-4-30-MET	51.5"	30"	20"	173	\$1,785
FLFSQP-4-36-MET	51.5"	36"	20"	196	\$1,961
FLFSQP-4-42-MET	51.5"	42"	20"	241	\$2,143

WEDGE, DESIGNER OR SLANT PULL					+\$100
-------------------------------	--	--	--	--	--------

## NOTES

Supporting lateral file with lock and finished top cap.

Square drawer pulls, silver color. Square drawer front.

Order front to back file bars.

Free-standing Lateral Files must be bolted to a wall or bolted together

Specify pull when ordering.

Designer Pull has color options: specify color when ordering. (see page 8)

LATERAL FILE  
COUNTERWEIGHT

PART #	USAGE	WT. (LBS)	LIST
FLFCW-30	use with 30" W lateral file *	23	\$61
FLFCW-36	use with 36" W lateral file **	46	\$92
FLFCW-42	use with 42" W lateral file **	46	+ \$92

## NOTES

Attaches securely to the inside back of the lateral file.

For use with 2-Drawer lateral files only.

\* Includes one 20 lb counterweight  
\*\* Includes two 20 lb counterweights, for a total of 40 lbs of counterweight

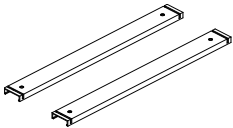
FRONT-TO-BACK  
FILE BARS

PART #	HEIGHT	WIDTH	DEPTH	WT. (LBS)	LIST
FFB	3/8"	1 3/16"	15 11/16"	1	+ \$25

## NOTES

Front to back file bars.

Package of two.

Order one package of two per drawer.

Color: Black.

## Freestanding Credenza Units

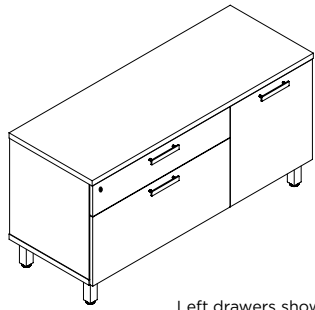

Left drawers shown

### DESCRIPTION

Locking storage unit with drawers, door and feet.

### NOTES

- Drawers can be specified L for left side drawers or R for right side drawers
- Specify pull when ordering
- Designer pull has color options: specify color when ordering. (See page 8)

### SPECIFICATION OPTIONS

**product #:** see charts below  
**top, front & casing finish:** See page 6  
**drawer side:** L for Left, R for Right  
**feet:** Post, Taper or Inset (note finishes below)  
**pull:** See page 8

### ORDER EXAMPLE

**product #:** FCREDSQAP.1842L  
**top finish:** M13  
**front finish:** M28  
**casing finish:** M28  
**foot:** TAPER  
**foot finish:** SV  
**pull:** Slant pull

### CREDENZA FEET OPTIONS

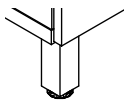

Post foot



Taper foot (CW, BU, SV)



Inset foot (CW, BU, SV)

### CREDENZA PULL OPTIONS

#### DEFAULT PULL

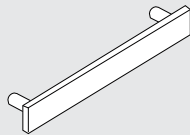

Bar Pull

#### PREMIUM PULLS

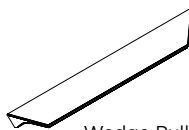

Wedge Pull



Designer Pull  
 • Cloud White/Red  
 • Cloud White/Green  
 • Cloud White/Grey

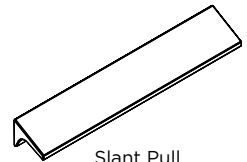

Slant Pull

### FREESTANDING CREDENZA: 42" WIDE

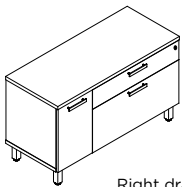

Right drawers shown

PART #	HEIGHT	WIDTH	DEPTH	WT. (LBS)	PRICE
FCREDSQAP.1842L	24"	42"	18"	—	\$1,341
FCREDSQAP.1842R	24"	42"	18"	—	\$1,341

**NOTES**  
 Freestanding Credenza with feet, storage unit and drawers.  
 Square drawer front  
 Specify pull when ordering  
 Designer pull has color options: specify color when ordering. (See page 8)

### FREESTANDING CREDENZA: 48" WIDE

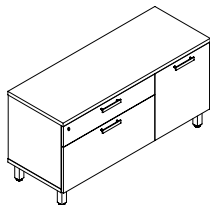

Left drawers shown

PART #	HEIGHT	WIDTH	DEPTH	WT. (LBS)	PRICE
FCREDSQAP.1848L	24"	48"	18"	—	\$1,467
FCREDSQAP.1848R	24"	48"	18"	—	\$1,467

**NOTES**  
 Freestanding Credenza with feet, storage unit and drawers.  
 Square drawer front  
 Specify pull when ordering  
 Designer pull has color options: specify color when ordering. (See page 8)

### FREESTANDING CREDENZA: 60" WIDE

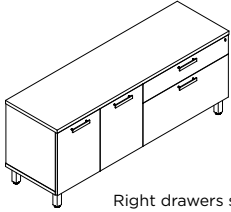

Right drawers shown

PART #	HEIGHT	WIDTH	DEPTH	WT. (LBS)	PRICE
FCREDSQAP.1860L	24"	60"	18"	—	\$1,651
FCREDSQAP.1860R	24"	60"	18"	—	\$1,651

## NOTES

Freestanding Credenza with feet, storage unit and drawers.

Square drawer front.

Specify pull when ordering

Designer pull has color options: specify color when ordering. (See page 8)

### CREDENZA CUSHION

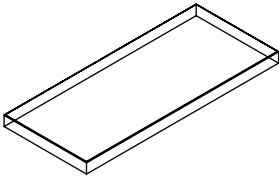

PART #	HEIGHT	WIDTH	DEPTH	WT. (LBS)	PRICE
FCREDSQ.CUSH30	1.75"	30"	18"	—	\$280
FCREDSQ.CUSH36	1.75"	36"	18"	—	\$286
FCREDSQ.CUSH42	1.75"	42"	18"	—	\$322
FCREDSQ.CUSH48	1.75"	48"	18"	—	\$358
FCREDSQ.CUSH60	1.75"	60"	18"	—	\$430

## NOTES

For use with Credenza only.

Specify standard fabric.

Passage and Terrain fabrics can not be used on mobile cushions. (See page 4)

## Freestanding Credenza Units

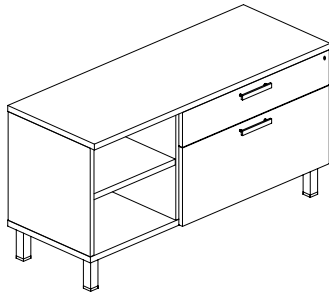

Right drawers shown

### DESCRIPTION

Locking storage unit with drawers and open shelves.

### NOTES

- Drawers can be specified L for left side drawers or R for right side drawers
- Specify pull when ordering
- Designer pull has color options: specify color when ordering. (See page 8)

### SPECIFICATION OPTIONS

**product #:** see charts below  
**top, front & casing finish:** See page 6  
**drawer side:** L for Left, R for Right  
**feet:** Post, Taper or Inset (note finishes below)  
**pull:** See page 8

### ORDER EXAMPLE

**product #:** FCREDSQOP:1842L  
**top finish:** M13  
**front finish:** M28  
**casing finish:** M28  
**foot:** TAPER  
**foot finish:** SV  
**pull:** Slant pull

### CREDENZA FEET OPTIONS

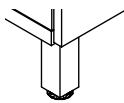

Post foot (Brushed only)



Taper foot (CW, BU, SV)



Inset foot (CW, BU, SV)

### CREDENZA PULL OPTIONS

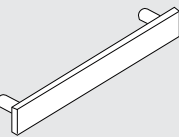

Bar Pull



Wedge Pull

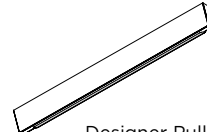

Designer Pull  
 • Cloud White/Red  
 • Cloud White/Green  
 • Cloud White/Grey

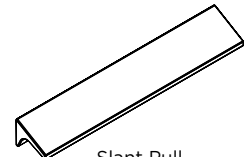

Slant Pull

### FREESTANDING CREDENZA: 42" WIDE

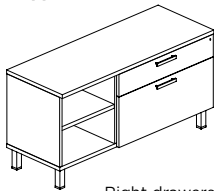

Right drawers shown

PART #	HEIGHT	WIDTH	DEPTH	WT. (LBS)	PRICE
FCREDSQOP:1842L	24"	42"	18"	—	\$1,133
FCREDSQOP:1842R	24"	42"	18"	—	\$1,133

**NOTES**  
 Freestanding Credenza with feet, open shelves and drawers.  
 Square drawer front  
 Specify pull when ordering  
 Designer pull has color options: specify color when ordering. (See page 8)

### FREESTANDING CREDENZA: 48" WIDE

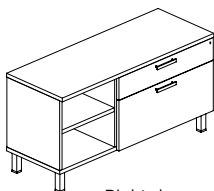

Right drawers shown

PART #	HEIGHT	WIDTH	DEPTH	WT. (LBS)	PRICE
FCREDSQOP:1848L	24"	48"	18"	—	\$1,260
FCREDSQOP:1848R	24"	48"	18"	—	\$1,260

**NOTES**  
 Freestanding Credenza with feet, open shelves and drawers.  
 Square drawer front  
 Specify pull when ordering  
 Designer pull has color options: specify color when ordering. (See page 8)

### FREESTANDING CREENZA: 60" WIDE

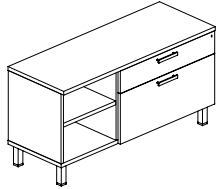

Right drawers shown

PART #	HEIGHT	WIDTH	DEPTH	WT. (LBS)	PRICE
FCREDSQOP.1860L	24"	60"	18"	—	\$1,443
FCREDSQOP.1860R	24"	60"	18"	—	\$1,443

#### NOTES

Freestanding Credenza with feet, open shelves and drawers.

Square drawer front

Specify pull when ordering

Designer pull has color options: specify color when ordering. (See page 8)

### CREENZA CUSHION

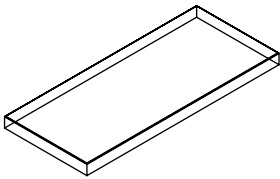

PART #	HEIGHT	WIDTH	DEPTH	WT. (LBS)	PRICE
FCREDSQ.CUSH30	1.75"	30"	18"	—	\$280
FCREDSQ.CUSH36	1.75"	36"	18"	—	\$286
FCREDSQ.CUSH42	1.75"	42"	18"	—	\$322
FCREDSQ.CUSH48	1.75"	48"	18"	—	\$358
FCREDSQ.CUSH60	1.75"	60"	18"	—	\$430

#### NOTES

For use with Credenza only.

Specify standard fabric.

Passage and Terrain fabrics can not be used on mobile cushions. (See page 4)

### WORKSURFACE SUPPORT BRACKETS

PART #	PRICE
FSPL.CRED	\$160

#### NOTES

Worksurface support brackets (pair)

Credenza mounted. For use with FCREDSQ.

Finishes: CW, MT, DT, BU

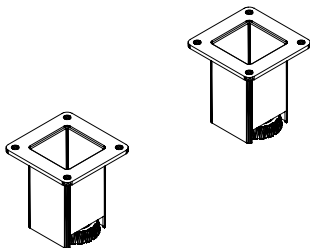



## Freestanding Towers

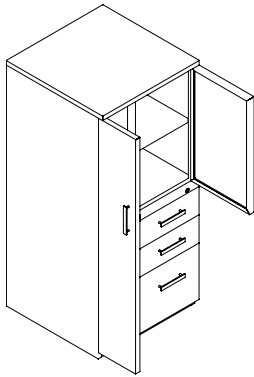

Left side wardrobe shown.

### DESCRIPTION

Storage with drawers.

### NOTES

- Drawers have lock
- Door and cabinet do not have locks
- Specify pull when ordering
- Designer pull has color options: specify color when ordering. (See page 8)
- Bar Pull will be shipped in box on ALL orders, Premium Pulls will ship separately

### SPECIFICATION OPTIONS

**product #:** see charts below  
**finish:** CW Cloud White, DT Dark Tone, MT Medium Tone (painted metal)  
**wardrobe side:** L for Left, R for Right  
**pull:** page 8

### ORDER EXAMPLE

**product #:** FCREDSQAP1842L  
**finish:** CW  
**wardrobe side:** L  
**pull:** Slant pull +75 (see upcharge below)

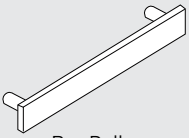
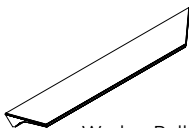
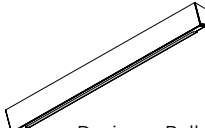
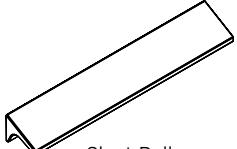
	DEFAULT PULL	PULLS REQUIRING UPCHARGE		
PEDESTAL PULL OPTIONS	 Bar Pull	 Wedge Pull	 Designer Pull • Cloud White/Red • Cloud White/Green • Cloud White/Grey	 Slant Pull

### FREESTANDING TOWERS 53" HIGH

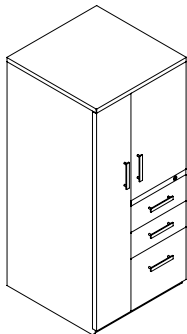

Left side wardrobe shown.

PART #	HEIGHT	WIDTH	DEPTH	WT. (LBS)	LIST	NOTES
FTBBFP.2453L	53"	24"	24"	—	\$1,995	Free-standing tower, 53" high Square pulls, silver color Square drawer front Order side to side file bars Specify wardrobe on left or right side Specify pull when ordering Designer pull has color options: specify color when ordering. (See page 8)
FTBBFP.2453R	53"	24"	24"	—	\$1,995	
WEDGE, DESIGNER OR SLANT PULL					+\$125	

## Freestanding Towers / continued

### FREESTANDING TOWERS 67" HIGH

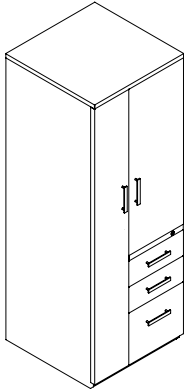

Left side wardrobe shown.

PART #	HEIGHT	WIDTH	DEPTH	WT. (LBS)	LIST	NOTES
FTBBF.2467L	67"	24"	24"	—	\$2,495	Free-standing tower, 67" high
FTBBF.2467R	67"	24"	24"	—	\$2,495	Square pulls, silver color Square drawer front Order side to side file bars
WEDGE, DESIGNER OR SLANT PULL					+\$125	Specify wardrobe on left or right side Specify pull when ordering Designer pull has color options: specify color when ordering. (See page 8)

## Pulls Lateral

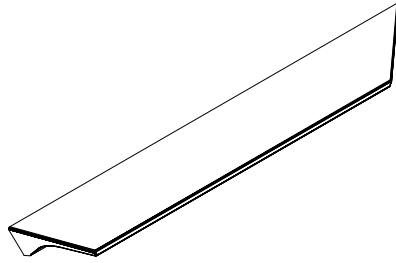

DESCRIPTION

3 different pull options to choose from

NOTES

- Wedge Pull for Lateral
- Designer pull has color options: specify color when ordering. (See chart below)
- Slant Pull for Lateral

SPECIFICATION OPTIONS

**product #:** see charts below  
**pull:** see charts below

ORDER EXAMPLE

**product #:** WEDGE-PULL-244  
**pull:** Wedge

### WEDGE PULL FOR LATERAL

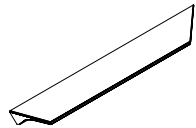

PART #	WT. (LBS)	LIST	NOTES
WEDGE-PULL-244	—	\$25	Wedge Pull for Lateral

### DESIGNER PULL FOR LATERAL

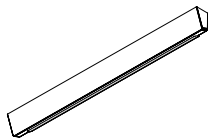

PART #	WT. (LBS)	LIST	NOTES
DESIGNER-PULL-250-RED	—	\$25	Designer Pull is CW (Cloud White) with non-slip color trim on underside. Trim available in 3 colors: Red, Green, and Grey
DESIGNER-PULL-250-GREEN	—	\$25	
DESIGNER-PULL-250-GREY	—	\$25	

### SLANT PULL FOR LATERAL

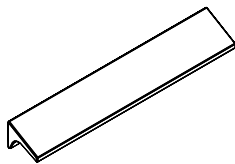

PART #	WT. (LBS)	LIST	NOTES
SLANT-PULL-244	—	\$25	Slant Pull for Lateral

## Pulls Pedestal

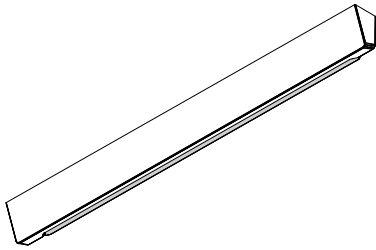

### DESCRIPTION

3 different pull options to choose from

### NOTES

- Wedge Pull for Pedestal
- Designer pull has color options: specify color when ordering. (See chart below)
- Slant Pull for the Pedestal

### SPECIFICATION OPTIONS

**product #:** see charts below  
**pull:** see charts below

### ORDER EXAMPLE

**product #:** DESIGNER-PULL-250-RED  
**pull:** Designer Pull, RED

### WEDGE PULL FOR PEDESTAL

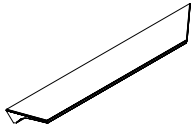

PART #	WT. (LBS)	LIST	NOTES
WEDGE-PULL-167	—	\$25	Wedge Pull for Pedestal

### DESIGNER PULL FOR PEDESTAL

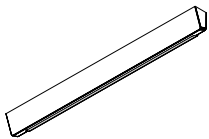

PART #	WT. (LBS)	LIST	NOTES
DESIGNER-PULL-250-RED	—	\$25	Designer Pull is CW (Cloud White) with non-slip color trim on underside. Trim available in 3 colors: Red, Green, and Grey
DESIGNER-PULL-250-GREEN	—	\$25	
DESIGNER-PULL-250-GREY	—	\$25	

### SLANT PULL FOR PEDESTAL

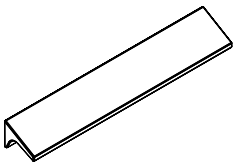

PART #	WT. (LBS)	LIST	NOTES
SLANT-PULL-167	—	\$25	Slant Pull for Pedestal

## Accessories

DESCRIPTION	SPECIFICATION OPTIONS
Workstation accessories.	<b>product #:</b> see charts below <b>finish:</b> CW Cloud White, DT Dark Tone, MT Medium Tone
NOTES	ORDER EXAMPLE
	<b>product #:</b> FTB.24 <b>finish:</b> CW

### TOOL BARS



PART #	HEIGHT	WIDTH	DEPTH	WT. (LBS)	LIST	NOTES
FTB.24	3.5"	24"	0.75"	2	\$64	Attaches to a panel of same width.
FTB.30	3.5"	30"	0.75"	2	\$78	
FTB.36	3.5"	36"	0.75"	3	\$91	Mounting hardware included.
FTB.42	3.5"	42"	0.75"	3	\$105	
FTB.48	3.5"	48"	0.75"	4	\$118	

### FLAT PAPER TRAY

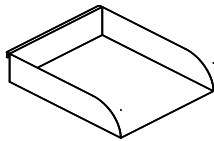

PART #	HEIGHT	WIDTH	DEPTH	WT. (LBS)	LIST	NOTES
FFPT	3"	10"	12"	2	\$40	Order tool bar separately.

### VERTICAL SINGLE TRAY

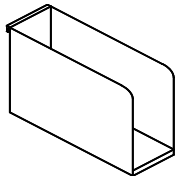

PART #	HEIGHT	WIDTH	DEPTH	WT. (LBS)	LIST	NOTES
FVST	8"	4"	12"	2	\$38	Order tool bar separately.

### VERTICAL TRIPLE TRAY

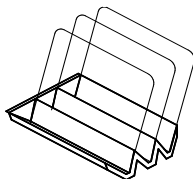

PART #	HEIGHT	WIDTH	DEPTH	WT. (LBS)	PRICE	NOTES
FVTT	11"	12"	12"	4	\$74	Order tool bar separately.

### CARPET GRIPPER

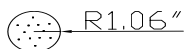

PART #	HEIGHT	WIDTH	DEPTH	WT. (LBS)	PRICE	NOTES
FTCG	—	2.125"	—	0.25	\$5	Plastic Gripper fits onto the adjustable glides of panel.  Finish: Black  Do not use on hard surface flooring.

**SINGLE MONITOR ARM**



PART #	HEIGHT	WIDTH	DEPTH	WT. (LBS)	LIST
FMA-S	—	—	—	—	\$525

NOTES

---

CW Finish

Includes attachment hardware for clamp, grommet and Verity track mount.

**DUAL MONITOR ARM**



PART #	HEIGHT	WIDTH	DEPTH	WT. (LBS)	LIST
FMA-D	—	—	—	—	\$750

NOTES

---

CW Finish

Includes attachment hardware for clamp, grommet and Verity track mount.

**Keyed-Alike Information**

DESCRIPTION

---

All Friant pedestals, lateral files and overhead cabinets can be keyed-alike.

SPECIFICATION OPTIONS

---

**product #:** see charts below

NOTES

---

- Keyed-Alike Lock Cores are sold in sets of 4
- Each set includes four Lock Cores, each with two keys, all with the same lock number
- One Lock Core Removal Key is shipped with every order.
- Additional Lock Core Removal Keys and Master Keys are also available

ORDER EXAMPLE

---

**product #:** FLCKA

**KEYED-ALIKE LOCKS**

PART #	DESCRIPTION	LIST
FLCKA-4	Lock Core Keyed-Alike (set of 4)	\$115
FLCKA-6	Lock Core Keyed-Alike (set of 6)	\$115
FCK	Lock Core Removal Key	\$17
FMK	Lock Core Master Key	\$17

