

Horizon High School



Horizon High School

Home of the Hawks



Registration Guide 2023-24

Horizon High School
5321 E. 136th Avenue
Thornton, Colorado 80602-7714
720-972-4400

Welcome to Horizon High School!

We are proud of our school and excited that you will be a student here. The Horizon Community envisions a school of excellence in academic achievement, arts education, athletic competition, and co-curricular activities. We are a safe, caring community that fosters global thinkers prepared for successful living in the 21st Century.

Whether you are an incoming freshman or continuing your high school career, we invite you to choose classes that will result in the best possible high school experience that Horizon can provide.

Horizon offers an extensive variety of classes that combine academic rigor with attention to integrating the humanities. Our fine arts offerings are excellent; our performing arts departments exceed high school programs throughout the state. Our core academic areas as well as practical/technical course offerings provide students with work force and college readiness. To better meet the needs of our students, we offer college preparatory (CP) classes starting at the 9th grade level as well as advanced placement (AP) classes that allow students to earn college credit. In addition, we offer the Horizon SOAR Program, which allows students to accelerate in a passion area and begin preparing for college early on.

In addition to academic excellence, the staff and students of Horizon High School are dedicated to creating a school in which every student feels connected and respected. Our goal is to create graduates that are accomplished and committed to lifelong learning.

Sincerely,

Erica Fleeman

Erica Fleeman, Principal
Horizon High School

HORIZON HIGH SCHOOL VISION
Reaching our potential today, meeting the challenges of tomorrow.

HORIZON HIGH SCHOOL

Mrs. Erica Fleeman.....	Principal
Mrs. Terra Paul	Assistant Principal
Mrs. Lisa Saunar	Assistant Principal
Mr. Marty Tonjes	Assistant Principal/Athletic Director
Mrs. Juana Budde	Counselor
Mrs. Deanna Gussman	Counselor
Mr. Michael Muedeking	Counselor
Mrs. Stacey Neumann	Counselor
Ms. Patty Rolison.....	Counselor
Ms. Anjela Schwab	Counselor
Mrs. Carolina Navarra	Registration Specialist

Registration Guidelines and Steps

The Master Schedule will be built from student requests. Courses and multiple selections of courses will be offered only if sufficient numbers of students enroll. You will be selecting classes for the entire school year. All students will register as full time students at Horizon High School. Students and parents should select classes wisely and carefully during the registration process as staffing and resources are impacted by these selections. Schedule changes are very difficult to obtain because the Master Schedule is built on student requests.

Listed below are some criteria you should use to make these wise choices.

1. Review the high school graduation requirements.
2. Review the college entrance requirements.
3. Review the course descriptions online. Carefully read the descriptions of those classes you are interested in taking and any pre-requisites prior to registration.
4. If you are an athlete, cheerleader/pom, in band, choir, or Student Government, it is your responsibility to know and understand the eligibility requirements. If you are an athlete, you will also need to review your selections with regard to the NCAA Clearinghouse guidelines.
5. All students are required to sign up for a minimum of **6 credits**. Music, Journalism, Yearbook, and Student Government may be selected for an additional credit. Additionally, all students must enroll for a minimum of **3 core subjects** (English, Social Studies, Science, Math or World Language).
6. Students testing below grade level in reading or math may automatically be placed in a supplemental reading or math class.
7. Follow the instructions on your registration form.

The content provided is current and timely as of January 2023. Information is presented in summary form and policies, procedures, fees and course titles are subject to change.

Schedule Additions/Changes

Once registered, students may request a change for only the following reasons:

1. Failed a class/missing prerequisite
2. Physical disability (must have doctor's excuse)
3. Previously earned credit in same class
4. Less than six credits
5. Double Scheduled
6. Senior needs graduation credit

Important Note: A "withdrawal" from class after 3 days for a block class or 5 days for a single period class is a "WF" (withdrawal fail) and is computed into the cumulative grade point average. Until a schedule change is approved, the student must continue to attend all classes on his/her schedule.

Graduation Requirements

Graduation includes two parts:

1. Completion of Credits and Coursework
2. Demonstration of College and Career Readiness in English and Math

Part 1

Graduation Requirements – Credits and Course Work	2021 and beyond
English	4.0
Math	3.0
Science	3.0
Social Studies	1.5
US Government/Civics	.5
US History	1.0
Physical Education*	1.0
Fine or Practical Arts	2.0
Electives	7.0
TOTAL	23

*There will be NO PE waivers and **.5 credit must be Health**

Part 2

Students must receive a minimum score in English and Math in order to demonstrate College and Career Readiness. Students may use different assessments to show demonstration in English and Math.

Assessment	English	Math
ACCUPLACER	62 Reading or 70 Sentence Skills	61 Elementary Algebra
Next Generation ACCUPLACER	241 Reading or 236 Writing	255 on AR or 230 on QAS
ACT	18	19
Work Keys	Bronze or Higher	Bronze or Higher
Advanced Placement (AP)	2	2
ASVAB	31	31
Concurrent Enrollment	Passing Grade	Passing Grade
District Capstone	Passing Grade *	Passing Grade *
Industry Certificate	Passing Grade *	Passing Grade *
International Baccalaureate (IB)	4	4
SAT	470	500
Collaborative Developed Assessment	In Process	In Process

*Currently in development

Capstone/Big Idea Project:

Big Idea Project is a student development organization that unleashes the potential of students to become leaders with the experience and skills they need for success after high school. Through the Big Idea Project, students learn professional skills, character and leadership while they take responsibility to solve real problems in the community to get real results. Students walk away from the experience with a professional portfolio they can use for college applications and future employment. They also gain the confidence to overcome challenges that come their way. For the project, students work in teams to solve a social problem and work with a business mentor. Final projects will be presented to community members to culminate the class.



**Students
Of
Academic
Rigor**

SOAR Honors Program

The Horizon SOAR Honors program is a school-wide individualized program designed to enlighten, enrich and excite students. The SOAR program provides structure and support for high achieving students to prepare them for college success. Individual students select their own educational area of emphasis or “major” and a program is then designed specific to that “major”. The three choices for a “major” are:

- (1) Science, Math, Technology
- (2) Humanities
- (3) Arts (Performing, Visual, and Practical)

Through creative scheduling which includes blocking courses to accelerate learning, SOAR students have the opportunity to advance to the highest level of coursework (Advanced Placement [AP] and/or college courses). In addition to maintaining a 3.25 GPA, the SOAR program requires students to participate in extra-curricular activities, become involved in community service, and grow through advanced learning experiences. The goal of SOAR is to (1) furnish a variety of learning opportunities which challenge and engage students during high school and (2) provide a well-rounded experience that enriches a resume for the competitive college/scholarship application process.

ADVANCED PLACEMENT TEST PREPARATION COURSES

Not every AP course will be offered every year.

Horizon courses recommended to prepare students for AP Exams include:

AP English Literature/Composition
AP Studio Art 2D
AP Studio Drawing
AP Biology
AP Chemistry
AP US History
AP US Govt&Politics
AP Calculus AB
AP Calculus BC
AP Statistics
AP Spanish
AP German

AP English Language/Composition
AP Studio Art 3D
AP Art History
AP Environmental Science
AP Physics C: Mechanics
AP Physics C: Electricity & Magnetism
AP Psychology
AP World History
AP French
AP Computer Science Principles
AP Computer Science A

AP Application is
required at time of
registration.

Please note that courses designated as AP are regulated by the College Board through the AP Course Audit process. AP classes are graded on the weighted grading scale. Students enrolled in AP classes at Horizon **will be required to take the AP exam in May.** **ALL STUDENTS REQUESTING AN AP CLASS WILL BE REQUIRED TO COMPLETE A CONTRACT OUTLINING ALL EXPECTATIONS FOR THAT CLASS.** The current fee is \$96.00 per test and is subject to change based on the College Board. AP course application must be filled out and returned at time of registration.

POST SECONDARY OPTIONS ENROLLMENT ACT

Through the Colorado Legislature Post-Secondary Options Enrollment Act, juniors and seniors may attend approved post-secondary educational institutions to earn concurrent high school and/or college credit. The District may pay tuition if the student has exceeded all course offerings in that discipline. Students must notify the counselor of intent 60 days prior to the beginning of the course. See your counselor for approval and forms.

COLLEGE ADMISSION TESTS/STATE MANDATED ASSESSMENTS

There are two primary testing programs utilized by colleges for the purpose of admissions and placement:

- **P.S.A.T./N.M.S.Q.T.** - The Preliminary Scholastic Aptitude Test/National Merit Scholarship Qualifying Test is designed to give students (juniors) experience with tests similar to those required for college admissions. In addition, results of this test are used as a competitive examination in the National Merit program. Interested Juniors take this test in October. In addition, the State requires all Sophomores to take the P.S.A.T. on a prescribed date in April.
- **COLLEGE BOARD - SCHOLASTIC APTITUDE (S.A.T.) AND ACHIEVEMENT TESTS** - The S.A.T. is used by colleges and universities as an entrance test. The State requires all Juniors to take the S.A.T. on a prescribed date in April. The S.A.T. I consists principally of two sections: one verbal and one math. The test is designed to provide reliable indications of a student's ability to do college level work and is administered nationally in November, December, January, March, May, and June. Achievement Tests provide information about a student's knowledge of subject matter and are used extensively for placement purposes by some institutions. Students should consult with their counselor to determine institution requirements. The S.A.T. II: Some colleges require students to take the S.A.T. II test(s) in various subject areas. This would usually be an out of state college.
- **AMERICAN COLLEGE TEST (A.C.T.)** - The A.C.T. results are accepted by all colleges in Colorado. A.C.T. tests are designed to measure the student's ability to perform the kind of intellectual tasks typically performed by college students. The major portion of the A.C.T. battery consists of four tests: English, Mathematics, Reading, and Science Reasoning. The A.C.T. is administered nationally in professional test centers five times each year: October, December, February, April, and June.

SAT/ACT Review is available in the Counseling and Career Center in various formats. Possible preparation classes may be held on weekends and evenings and will be announced at a later time.

IMPORTANT INFORMATION FOR THE COLLEGE-BOUND STUDENT ATHLETE

A student entering college and wishing to participate in Division I or II athletics must be certified by the NCAA Eligibility Center. The Eligibility Center ensures consistent application of NCAA initial-eligibility requirements for all prospective student athletes at all member institutions. Athletes need to start the certification early – during their sophomore or junior year in high school. Necessary information is available in the Counseling Center.

TO BE CERTIFIED BY THE NCAA ELIGIBILITY CENTER YOU MUST:

- 1. Graduate from high school.** (You should apply for certification during sophomore or junior year of high school if you think you may wish to participate in athletics in college.)
- 2. A sliding scale is used in conjunction with a student's GPA and ACT/SAT score for both Division I and II.** A core curriculum of at least 16 academic credits must be successfully completed during grades 9 through 12. Only courses listed as approved on your high school's "List of NCAA Approved Core Courses" can be used to calculate your NCAA GPA. (See your counselor for the most current list of accepted classes). The chart below indicates the number of years of NCAA core courses that must be completed.
- 3. Minimum test scores on the ACT and SAT must be attained based on a sliding scale.**

Core Credits Required for NCAA Certification		
	Division I	Division II
English	4 credits	3 credits
Math *	3 credits*	2 credits
Science **	2 credits	2 credits
Social Studies	2 credits	2 credits
From English, Math, or Science (additional courses)	1 credit	3 credits
Additional Core (From any above area, world language, non-doctrinal religion, or philosophy)	4 credits	4 credits
TOTAL CORE UNITS REQUIRED	16	16

*includes at least 2 credits of mathematics courses at the level of Algebra I or above.

** including at least one year of lab science

***Please see Counseling Department for additional guidance and registration information.**

FOUR YEAR PLANNING FORM

It is important for the student to review requirements for graduation and to plan accordingly. At the same time, it is to the student's benefit to explore a variety of interests and electives at all four grade levels. Use this page to plan for courses you would like to take.

9th GRADE PLAN

1 st Semester	2 nd Semester	Credits
English 9/Lit/Comp OR CP English 9 Lit/Comp		
World History & Geography OR AP World History		
Biology OR CP Biology		
Math (9 th graders will be placed based on district data)		
Total Credits		

10th GRADE PLAN

1 st Semester	2 nd Semester	Credits
English 10 Lit/Comp OR CP English 10 Lit/Comp		
World History & Geography OR AP World History		
Science		
Math		
Total Credits		

11th GRADE PLAN

1 st Semester	2 nd Semester	Credits
American Lit/Comp OR AP Language		
US History I/II OR AP US History		
Science		
Math		
Total Credits		

12th GRADE PLAN

1 st Semester	2 nd Semester	Credits
English 12 Lit/Comp OR English 12 Lit/Comp: Comparative Media Studies OR AP Literature		
2 additional Core Areas Science, Math, Social Studies, World Language		
Total Credits		

Business, Marketing, and Technology

All courses in the Business/Marketing/Technology Department meet the Fine & Practical Arts graduation requirement. Students taking business courses acquire 21st Century workplace skills, college readiness skills, and a general business background. Business/Marketing/Technology classes are recommended for entry-level job training or college preparation. Students can earn additional elective credit by participating in Work Based Learning. FBLA and DECA are integral components of the Business/Marketing program. The Advanced Marketing course allows students to earn dual credit at both Horizon and Front Range Community College (FRCC). Students earn 3 free college credits in the Advanced Marketing course.

Business

Accounting (yearlong- must register for both)
10th, 11th, 12th

Semester 1: Accounting Principles 1A

Semester 2: Accounting Principles 1B

Prerequisite: Completed and passed Math 1

Personal Finance

10th, 11th, 12th - .5 credit

Prerequisite: Completed and passed Math 1

Intro. to Business

9th, 10th, 11th, 12th - .5 credit

Technology

Intro. To PC Applications

9th, 10th, 11th, 12th - .5 credit

Web Design

9th, 10th, 11th, 12th - .5 credit

Available for all Business & Marketing Courses

FBLA: In order to participate in FBLA, students must be enrolled in a Business, Marketing, or Technology class

Work-Based Learning: Business: Students working 125 hours in a semester can earn .5 an elective credit while enrolled in a Business, Marketing or Technology Course. See online course description for more information.

Marketing

Marketing (yearlong- must register for both)

Semester 1: Principles of Marketing A

Semester 2: Principles of Advertising

9th, 10th, 11th, 12th - 1 credit

Entrepreneurship (yearlong - must register for both)

Semester 1: Intro to Entrepreneurship

Semester 2: Leadership

10th, 11th, 12th - 1 credit

Recommended Prerequisite: Mktg. or Adv. Mktg.

Advanced Marketing (College Marketing)

Earn 3 free college credits! (yearlong - must register for both)

10th, 11th, 12th - 3 college credits, 1 Horizon credit

Semester 1: Strategic Marketing

Semester 2: Consumer Behavior

Prerequisite: (Marketing: Principles of Marketing A, Principles of Advertising) or teacher approval by Mrs. Valentine. This is a college credit course and a form is required.

Social Media for Business

9th, 10th, 11th, 12th - .5 credit

DECA: In order to participate in DECA, students must be enrolled in a Marketing class.

COMPUTER AND DIGITAL TECHNOLOGY



Computer and Digital Technologies courses meet the Fine & Practical Arts (elective) graduation requirement. Courses cover coding, networking, software development, hardware, the internet, IOT, cybersecurity, general computer science principles, and more. AP credit and other technical certifications may be earned throughout these courses.

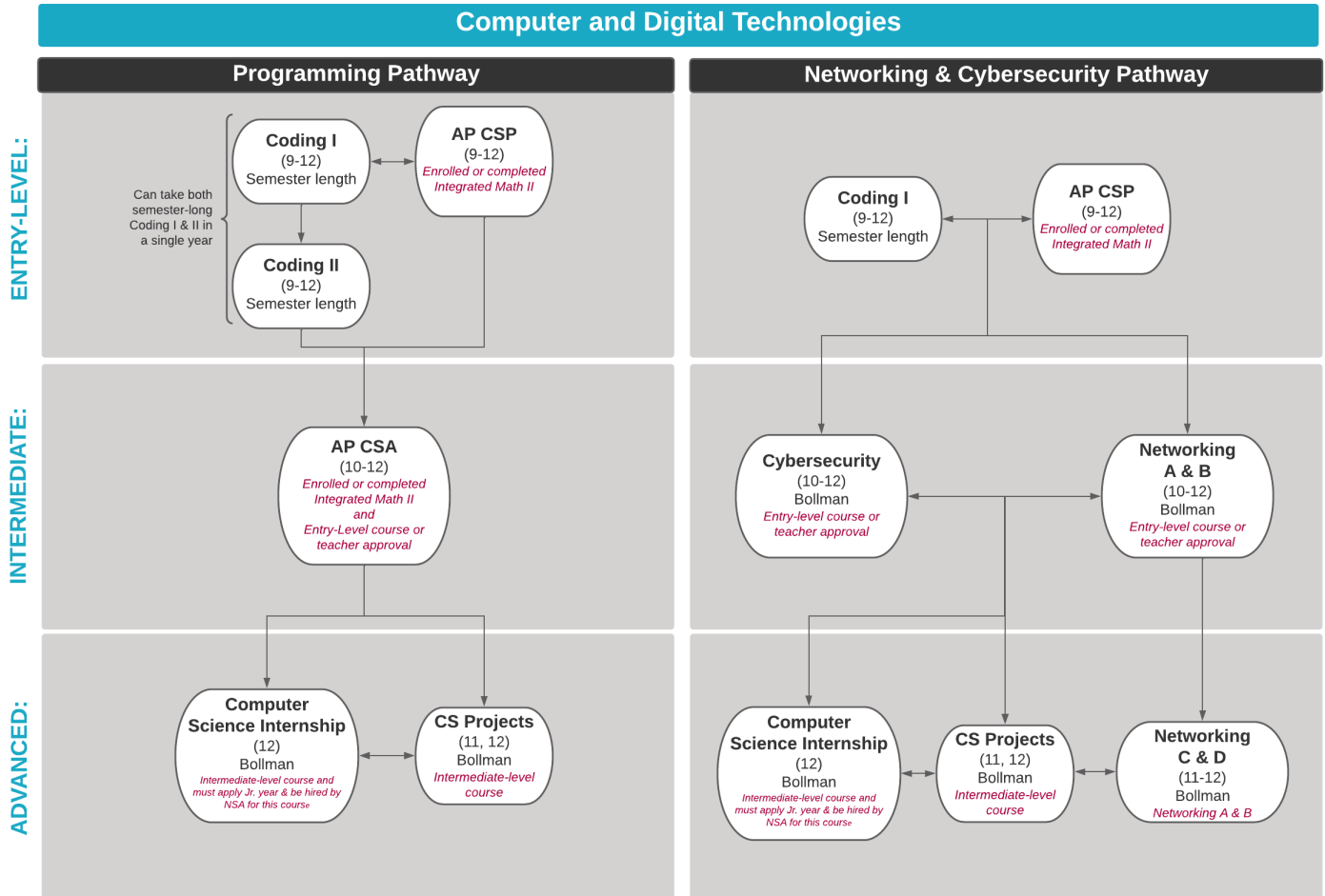

FutureForward at Horizon offers introductory Computer and Digital Technologies courses: Web Design, Coding I, Coding II, AP Computer Science Principles, and AP Computer Science A. Students interested in further coursework may take courses at Bollman until the pathway grows at Horizon. Computer and Digital Technologies courses at Bollman are available to be taken synchronously online. Contact your counselor at Horizon or Bollman for details.

Available for all Computer and Digital Technology courses

FBLA: All students will participate in FBLA activities. Competing in state and national events are optional.
Work-based Learning: Elective credit can be earned through job experience if a student is enrolled in a Future Forward course: Business/Marketing, Computer and Digital Technologies, and Family and Consumer Science. Contact your teacher or your counselor for more information.

ENGLISH

The content provided is current and timely as of January 2023. Information is presented in summary form and policies, procedures, fees and course titles are subject to change.

These are the required courses at each grade level:

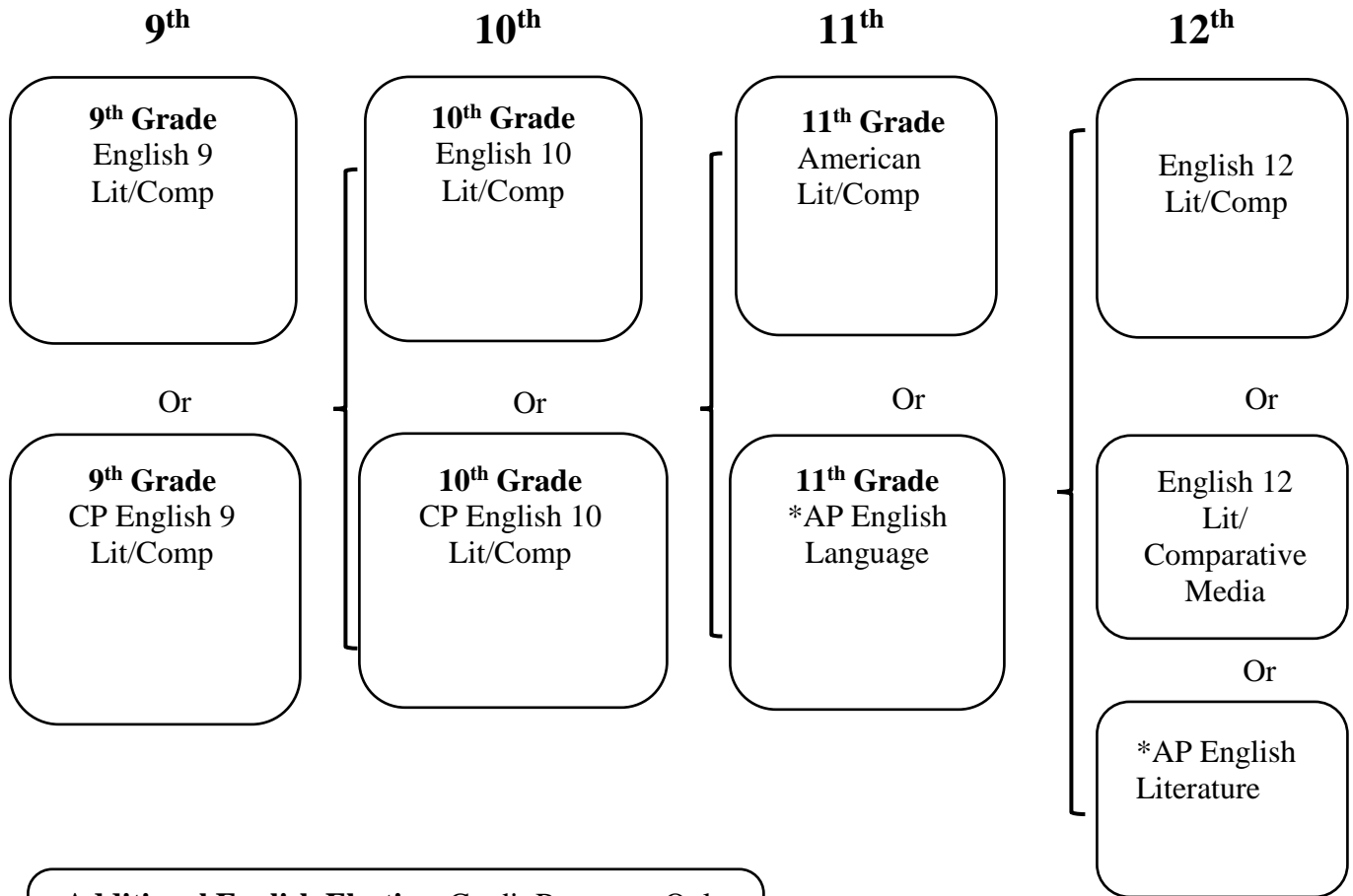

Additional English Elective: Credit Recovery Only
Individualized Lit/Comp - .5 credit

***AP application due at time of registration for all AP courses.**

A complete listing of courses and their descriptions can be viewed on our website at www.horizon.adams12.org/course-guide

FAMILY & CONSUMER SCIENCE

All Family/Consumer Science courses meet the Fine and Practical Arts graduation requirement. Courses cover life skills and family relations, foods and nutrition, child development and careers.

FUTURE FORWARD

at Horizon High School

11th and 12th grade choices

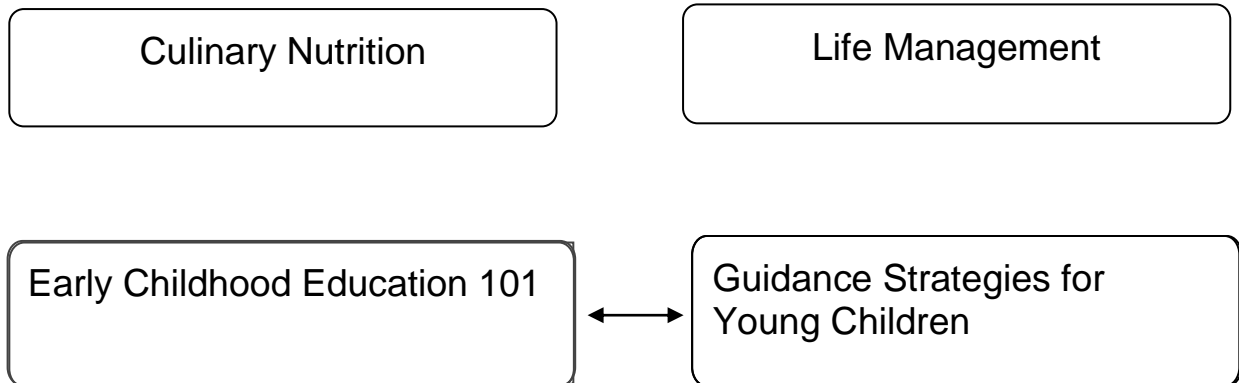

Students in the following classes are given the opportunity to observe and work in the Early Learning Center:

Early Childhood Education 101 (ECE 101)

Guidance Strategies for Young Children (ECE 103)

Infant and Toddler Theory and Practice (ECE 111)

Introduction to Early Childhood Lab Techniques (ECE 102)

Additional credit is given for students working in the Early Learning Center during ECE Practicum.

Additional Benefits: Career and Technical Student Organization (CTSO) participation through FCCLA

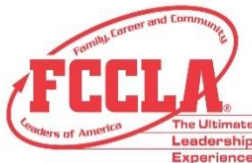

FINE ARTS – Visual Arts

The Art Department offers courses for the student interested only in a sampling of art experiences or for the student interested in an in-depth study of a specific art area. Art History is incorporated into the courses through videos and discussions. Classroom critique and portfolio development along with application of 21st century skills is emphasized. All classes in the Visual Arts department meet or exceed Colorado Content Standards for Visual Arts education.

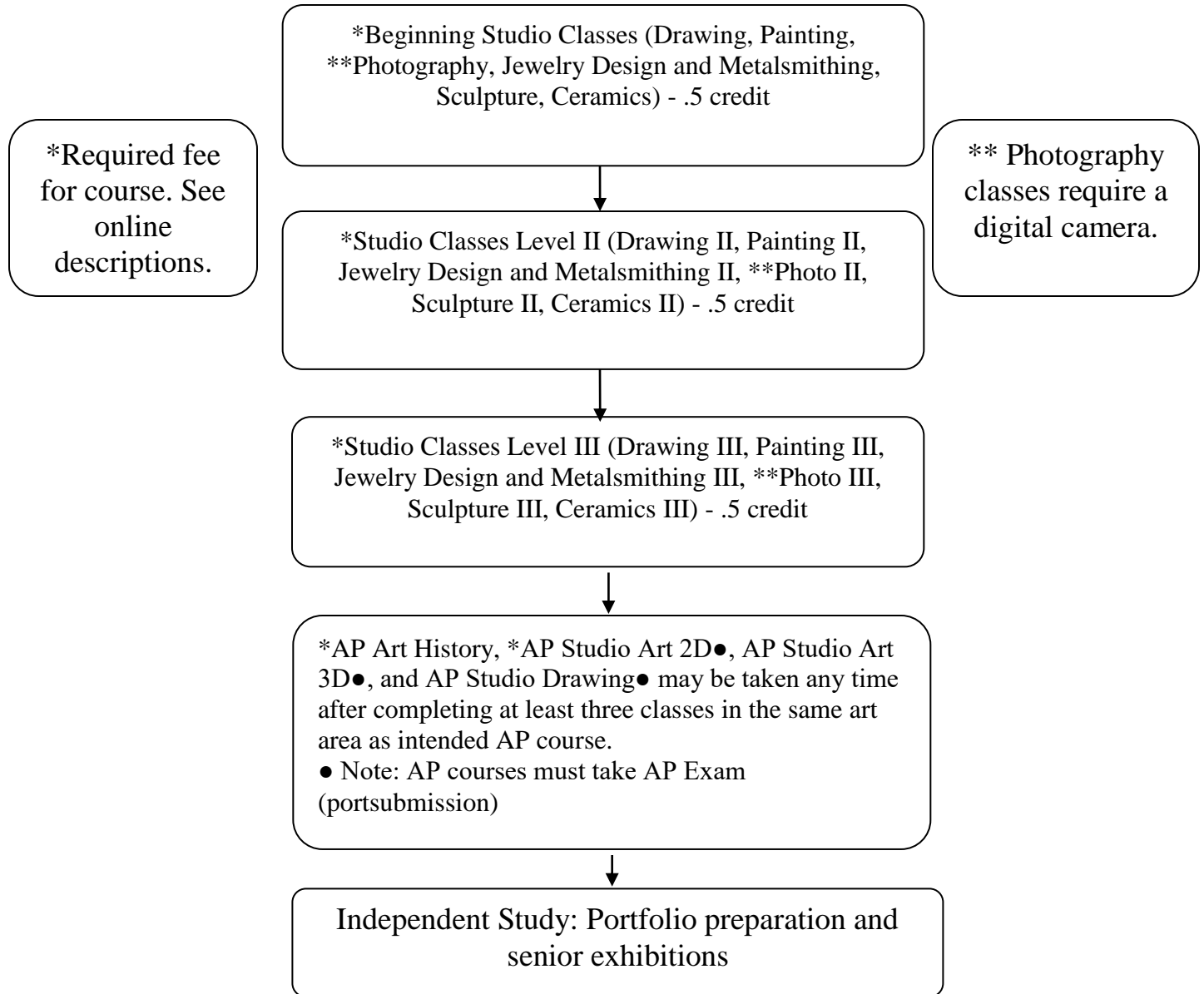

A complete listing of courses and their descriptions can be viewed on our website at www.horizon.adams12.org/course-guide

***AP Application and Portfolio Review** are required at time of registration for all AP courses. Students planning to graduate early should not take AP Art.

FINE ARTS – Theatre

Theatre Arts I: Introduction
9th, 10th, 11th, 12th - .5 credit Fine and Practical Art



Theatre Arts II: Performance
9th, 10th, 11th, 12th - .5 credit Fine and Practical Art
Prerequisite: Completed and passed Theatre Arts I.
(Or approval from Theatre Staff)



Theatre Arts III: Advanced Performance
10th, 11th, 12th - .5 credit Fine and Practical Art
Prerequisite: Completed and passed Theatre Arts II.

Tech Theatre
9th, 10th, 11th, 12th - .5 Fine and
Practical Art

Theatre Dance
9th, 10th, 11th, 12th - .5 Fine and
Practical Art

Film Study
10th, 11th, 12th - .5 credit Fine and Practical Art

Communications

Yearbook
10th, 11th, 12th - 1 credit
Application only.
Yearbook applications can be obtained in
the Counseling center.

Journalism
10th, 11th, 12th - 1 credit
Application only.
Newspaper applications can be obtained
in the Counseling center.

A complete listing of courses and their descriptions can
be viewed on our website at
www.horizon.adams12.org/course-guide

FINE ARTS – Music

The music department is organized in such a manner that students can continue with their studies from previous experiences, expand their abilities and talents, or explore music learning and experiences for the first time. The department offers classes for all levels of achievement in vocal music, instrumental music (winds, strings, and percussion), and music theory. Advanced performance classes require an audition. Students usually provide their own instruments and concert attire with the exception of Marching Band. The school has a limited inventory of band and orchestral instruments available for loan. Most of the school-owned instruments are the more expensive, unique wind, string, and percussion instruments.

Certain approved fees apply in instrumental classes.

Tenor-Bass Choir
9th, 10th, 11th, 12th

Chamber Choir
10th, 11th, 12th
(Audition consent)

Vocal Jazz I/II
10th, 11th, 12th
(Audition/instructor consent)

Treble Choir I
9th, 10th, 11th, 12th

Advanced Treble Choir
10th, 11th, 12th
(Audition consent)

Jazz Ensemble I/II/III
9th, 10th, 11th, 12th
(Audition and instructor consent – see registration guide)

Marching Band
9th, 10th, 11th, 12th
(Instructor Consent)

Concert Band
9th, 10th, 11th, 12th
(Instructor Consent)

Wind Ensemble
9th, 10th, 11th, 12th
(Audition, prior music
experience and instructor
consent)

Symphonic Band
9th, 10th, 11th, 12th
(Audition, prior music experience
and instructor consent)

Music Theory
9th, 10th, 11th, 12th

Concert Orchestra
9th, 10th, 11th, 12th
(Prior string experience is
required)

Symphonic Orchestra
10th, 11th, 12th
(Audition, prior string
experience and instructor
consent)

A complete listing of courses and their descriptions can be viewed on
our website at www.horizon.adams12.org/course-guide

MATHEMATICS

The Math Department offers a variety of courses for the college-bound and non-college-bound student. Students should be aware that many colleges and universities require four credits for admission. Activities in all math classes include in-class work, homework assignments, problem solving, practical applications, and the use of technology. A TI-83+ or TI-84 calculator is required for all math classes. Some prerequisites may be waived by permission of the instructor. The Math department is dedicated to ensuring that every Horizon student graduates with a strong background in the fundamentals of algebra, geometry, and statistics. Math courses for all 9th grade students will be assigned based on District and Middle School data.

- How to Use**
1. Find your current grade and course
 2. Look at future options to the right

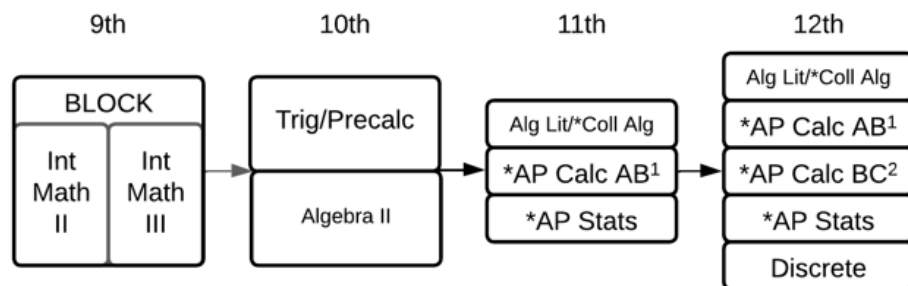
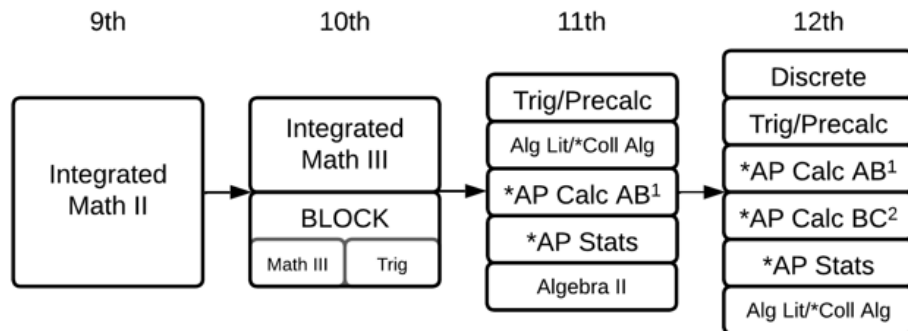
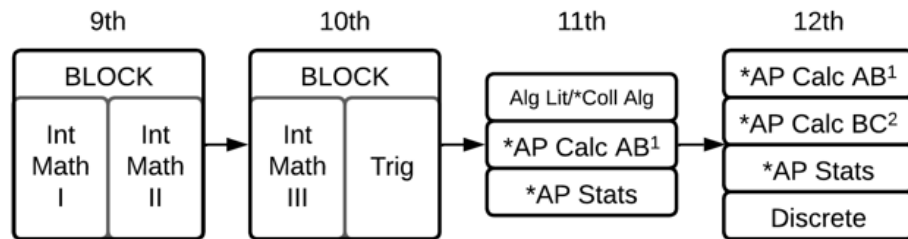
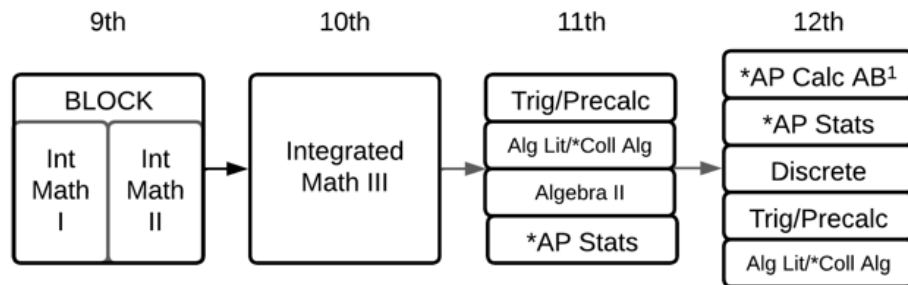
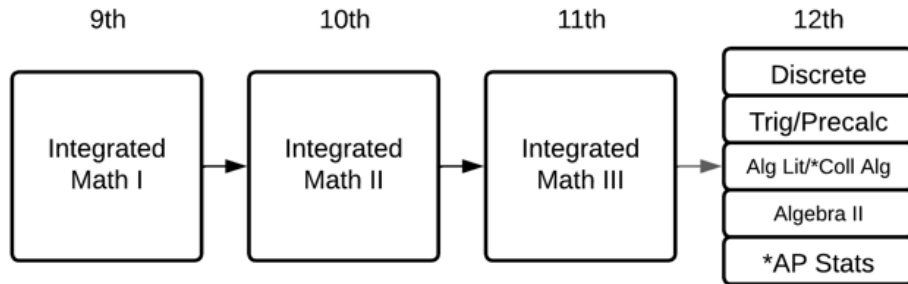

- AP & Concurrent Enrollment**
 *Form required at time of registration
- Prerequisites**
¹Trig/Precalc
²AP Calc AB
- Algebra II Administrator Placement Only**

PHYSICAL EDUCATION

The physical education curriculum is designed to provide students with educational activities which emphasize the development of skill proficiency in lifetime sports and offer carry-over value for adult life. Selected curricular activities engage the student in activities which encourage and emphasize the development of desirable social attitudes and both mental and physical fitness.

Healthy Choices satisfies .5 credit of the P.E./Health Requirement

Healthy Choices
9th-12th
.5 credit

All other P.E. classes will satisfy the remaining .5 P.E. credit requirement

Lifetime Fitness
9th-12th
.5 credit

Weight Training I
9th-12th
.5 credit

Team Sports I
9th-12th
.5 credit

Team Sports II
9th-12th
.5 credit

Racket Sports
9th-12th
.5 credit

Below are courses with special criteria

Positive PE
10th-12th
.5 credit

**application required*

Weight Training II
10th-12th
.5 credit

**Pre-requisite- Weights I*

Recreation Sports
12th
1.0 credit

** Required FEE for this course*

CP Anatomy & Physiology
11th-12th
.5 credit PE/.5 Science
**Integrated course: year-long*

**** Horizon PE T-shirt required for all P.E. courses (fee required)**

A complete listing of courses and their descriptions can be viewed on our website at www.horizon.adams12.org/course-guide

SCIENCE

Students are required to earn 3 credits to graduate but are encouraged to take 4 science classes. The various universities in Colorado have different requirements for admissions that you need to research. MOST universities require Chemistry or Physics for admission. *Regarding Biology, Chemistry & Physics; students may not acquire credit for general and CP level classes of the same content.* ALL CLASSES ARE 1 CREDIT UNLESS LISTED.

9th Offerings

10th Offerings

11th Offerings

12th Offerings

(If you have already taken a course as a 10th grader, then that course is no longer available as an 11th or 12th grade offering)

Earth Science

Concurrent enrollment in Math 2 or lower

Earth Science

Concurrent enrollment in Math 2 or lower

Environmental Science

.5 credit

Astronomy

.5 credit
Concurrent enrollment in Math 3 or lower

Chemistry

Completed Math 1 with a grade of C or better

Physics I

ALGEBRA based
Concurrent enrollment in Math 3 or 3/Trig Block with approval, Discrete or Algebra 2 ONLY

****Biology**

OR

CP Physics

TRIGONOMETRY based
Completed or concurrent Enrollment in Trig/Pre-Calculus

CP Chemistry

Completed Math 2 with a grade of C or better

OR

****CP Biology**

Grade level proficiency in Math and ELA

CP Physics

TRIGONOMETRY based
Completed OR concurrent enrollment in Trig/Pre-Calculus

CP Anatomy/Physiology

Completed Chemistry or Biology
.5 credit Science/.5 P.E.

Chemistry

Completed Math 1 with a grade of C or better

***AP Environmental Science**

Recommended "A" or "B" in Biology and Chemistry or instructor consent

OR

***AP Biology**

Recommended "A" or "B" in Biology and Chemistry or instructor consent

CP Chemistry

Completed Math 2 with a grade of C or better

***AP Physics C: Mechanics**

CALCULUS based
CP Physics and completion of or enrollment in AP Calculus or instructor

***AP Chemistry**

Recommended "C" in CP Chemistry and
A grade of "C" or better in Math 3 or instructor consent

Forensic Science

12th ONLY

A complete listing of courses and their descriptions can be viewed on our website at <http://horizon.adams12.org/course-guide>

*AP application required at time of registration.

**Refer to Registration Guide for additional details.

SOCIAL STUDIES

Three credits of social studies must be earned by all students at Horizon in order to satisfy graduation requirements. Freshmen must enroll in World History/Geography or AP World History. Sophomores must enroll in World History/Geography or AP World History. This is due to the district new course realignment process beginning with the 2023/24 school year. Juniors must enroll in the US History I/II or AP US History; this will satisfy the state's US History requirement for graduation.

Required for 9thGrade

9th Grade
World
History/Geography

OR

9th Grade
*AP World History

Required for 10thGrade

10th Grade
World
History/Geography

OR

10th Grade
*AP World History

Required for 11th Grade

11th Grade
US History I/II

OR

11th Grade
*AP US History

12th Grade Options

World Issues
1 credit

Topics in Philosophy
1 credit

Psychology
11th, 12th - .5 credit

Sociology
11th, 12th - .5 credit

*AP Psychology
12th - 1 credit

*AP application
required at time of
registration.

Civics & Constitutional Law
11th, 12th - .5 credit
This class meets the state civics req. for
graduation.

US History I (if not passed in 11th grade)
.5 credit

US History II (if not passed in 11th grade)
.5 credit

*AP US Government and Politics
12th - 1 credit

A complete listing of courses and their
descriptions can be viewed on our website at
www.horizon.adams12.org/course-guide

WORLD LANGUAGE

All courses in the World Language Department are Fine Arts credit. College-bound students should plan to take a two or three year sequence in the same language. If a student has taken a language in high school, he or she may be exempt from this requirement in college. For students who are not college-bound, language learning is still a beneficial experience. The expectation is that students can demonstrate proficient communication in real-world situations.

Level I

Spanish
German
French



Level II

Spanish
German
French



Level III

Spanish
German
French



+Level IV

Spanish ~
French
(Level IV German =AP)



*+Advanced Placement Language

(AP)
Spanish ~
German
French

Spanish for Heritage Speakers

By Teacher recommendation only

~ designated CU
Succeed Course

*AP application
required at time
of registration.

+ Eligible to
apply for the
Seal of Biliteracy
upon successful
completion of
Level IV or
Higher

A complete listing of courses and their
descriptions can be viewed on our website at
www.horizon.adams12.org/course-guide

SPECIAL /UNIQUE COURSE OFFERINGS

The following courses are by application only:

- *Yearbook
- *Journalism
- *Student Government
- *Positive P.E
- *Positive Art
- SOAR
- Adelante

*Applications can be obtained in the Counseling center.

The following courses are by placement only:

- Algebra II
- ELD Entering I
- ELD Emerging I
- ELD Developing I
- ELD Expanding I
- Accelerated Reading
- Special Education Courses (placement based on student's IEP)

Can be taken in addition to required 6 credits:

Student Assistant (Contract* between teacher and student must be signed)

*Contracts can be obtained in the Counseling center.

FUTURE FORWARD

at Bollman and Washington Square

Career and Technical Education 2023-2024

FutureForward Career and Technical Education (CTE) programming gives all students a competitive advantage as they enter college, career, or the military.

FutureForward Students:

- Explore opportunities that prepare them for high-demand careers and give them an edge entering college.
- Engage in authentic, hands-on learning.
- Equip themselves with relevant, rigorous, and practical skills.

LOCATIONS:

FutureForward at Bollman

9451 N. Washington St.
Thornton, CO
(720) 972-5820
<https://futureforward.adams12.org/bollman>
Principal: Janet Renden



FutureForward at Washington Square

12521 Washington St.
Thornton, CO
(720) 972-2900
<https://futureforward.adams12.org/washingtonsquare>
Principal: Marvin Lewis



futureforward.adams12.org



FutureForward at Bollman FutureForward at Washington Square

Adams 12 Five Star Schools offers Career and Technical Education (CTE) courses at its Bollman and Washington Square campuses to all high school students enrolled in the district. The District is committed to non-discrimination in relation to race, color, sex (including pregnancy, childbirth, and related medical conditions), age, religion, creed, national origin (including ethnicity), ancestry, genetic information (including family medical history), marital status, sexual orientation, transgender identity, gender identity, gender expression, or disability ("Protected Classes"), in its educational programs, activities, operations and employment decisions. Harassment is a form of discrimination. Anyone engaging in discrimination shall be subject to discipline in accordance with District policies. Any student or staff member who believes they have been discriminated against, or who witnesses discrimination (including bullying or harassment), will promptly make a report to an administrator or supervisor, or the Title IX/Non-Discrimination Coordinator. The District's interim Title IX/Non-Discrimination Coordinator is:

Megan Brooks

Educational Support Center (ESC)
1500 E. 128th Avenue
Thornton, CO 80241
720-972-4179
megan.brooks@adams12.org

FutureForward at Bollman is located at 9451 North Washington Street and FutureForward at Washington Square is located at 12521 Washington Street. Bus transportation is provided for Horizon, Legacy, Mountain Range, Northglenn, Thornton, and Vantage Point students from their home high schools to each of these campuses. It will be necessary for students enrolled in programs at both campuses to have travel time built into their schedules to allow for transportation between schools.

CAREER AND TECHNICAL COURSE OFFERINGS BY CAREER PATHWAY

AGRICULTURE	<i>Behavioral and Mental Health</i>
<i>Veterinary Assistant</i>	<i>Introduction to Educational Careers</i>
ARTS & DESIGN	<i>Teacher Cadet</i>
<i>Graphic Design</i>	SKILLED TRADES & TECHNICAL SCIENCES
<i>Video Production</i>	<i>Automotive Collision Repair and Refinishing</i>
CRIMINAL JUSTICE & PUBLIC SAFETY	<i>Automotive Technology</i>
<i>Crime Scene Investigation - CSI</i>	<i>Diesel Automotive Technology</i>
<i>Emergency Medical Technician – EMT</i>	<i>Construction, Mechanical, Electrical, and Plumbing</i>
<i>Firefighting</i>	<i>Welding Technology</i>
<i>Law Enforcement</i>	STEM & INFORMATION TECHNOLOGY
HEALTH SCIENCE	<i>AP Computer Science A</i>
<i>Introduction to Medical Careers</i>	<i>Cybersecurity</i>
<i>Medical Sciences</i>	<i>Networking</i>
<i>Advanced Medical Sciences - CNA</i>	<i>Computer Science Projects</i>
<i>Sports Medicine</i>	<i>Principles of Engineering - PLTW®</i>
HOSPITALITY, HUMAN SERVICES, & EDUCATION	<i>Aerospace Engineering - PLTW®</i>
<i>ProStart (Culinary Arts) - (Offered at ESC)</i>	<i>Computer Integrated Manufacturing –CIM- PLTW®</i>
<i>Baking & Pastry Applications (Culinary Arts) - (Offered at ESC)</i>	<i>Engineering Design & Development - Capstone PLTW®</i>

All Career and Technical Education courses meet the Fine/Practical Arts graduation requirement. These programs are offered to all Five Star students; however, it may be necessary for students to purchase supplies that are beyond the basic program requirements, and all programs have a course fee. Safety is a priority at both campuses and special clothing may be required for some program areas.

NOTE TO PARENTS:

- Any alcohol, drug, or other substance use violation could be grounds for denial of admission to a program or removal from a program once admitted.
- Excellent attendance is important in all FutureForward at Bollman and Washington Square programs. Five or more unexcused absences may result in a student being placed on an attendance contract. Failure to comply with an attendance contract may result in disenrollment from a program.
- Students enrolled in the Advanced Medical Sciences/CNA program will be required to have up-to-date immunizations, flu and COVID-19 vaccinations, a TB test, and a current physical.
- Students enrolled in the Advanced Medical Sciences/CNA and Teacher Cadet programs must provide their own transportation to off-site locations for projects, clinical rotations, and observations, or teaching experiences.
- Transportation is not provided for some programs. Please speak with a FutureForward at Bollman or Washington Square campus staff member for more details.
- It is required that all students who register for a FutureForward at Bollman and Washington Square program attend a pre-acceptance meeting in April.
- Juniors are given priority acceptance into some programs. Sophomores and seniors will be accepted on a “space available” basis.
- College credits are available in many FutureForward at Bollman and Washington Square programs. Contact the registrars or counselors for more information.

EXCEPTION TO THE THREE (3) CORE CLASS REQUIREMENT: According to Superintendent Policy 6340 Section 1.4.2, “Exceptions to the three (3) core class (1-1/2 credits) requirement may be made for students at FutureForward at Bollman and Washington Square providing such students can demonstrate competency in the core areas, and students with special circumstances as approved by the principal or designee.”

WORK-BASED LEARNING:

Potential Credit Earned: 0.5 - 1.0 credits per year, up to 2.0 credits total toward graduation

Interested students who are enrolled in a pre-approved Career and Technical Education course (CTE), or who have completed the pre-approved CTE pathway, may choose to participate in Work-Based Learning.

In Work-Based Learning, students will have the opportunity to apply their classroom knowledge to their job. Students will work with the Work-Based Learning coordinator throughout the semester. **Students should not enroll in Work-Based Learning as a separate class on the course registration selection form. The Work-Based Learning Coordinator will sign up students after courses have begun each semester.**

- Students must work a minimum of 125 documented hours to earn 0.5 credits.
- Students may ONLY earn 0.5 credits per semester.
- Students must work a minimum of 250 documented hours to earn 1.0 credit for the entire school year.

- Students cannot earn more than 1.0 credit per school year and may ONLY earn a maximum of 0.5 credits per semester.
- Students may not be enrolled in and/or receive credit for more than one Work-Based Learning course at a time.
- Students may not count more than 2.0 Work-Based Learning credits towards graduation requirements.
- Work-Based Learning credit may not be included in, nor does it count toward, the 6.0 credit total required yearly for each student.
- Students must complete a Work-Based Learning agreement to enroll.
- Students must pass the CTE course they are enrolled in in order to earn Work-Based Learning credit that semester.

SERVICE LEARNING

Service Learning Credit can be awarded to students that complete 60 hours of unpaid approved volunteer experience within a semester. Students need to submit the Student Volunteer Time Sheet and Work Ethics Evaluation Form completed by a supervisor from the approved volunteer company and/or organization. Hours will be verified before credit is awarded. Students must be enrolled and in good standing in a FutureForward at Bollman or Washington Square program the semester the Service Learning hours are completed and credit is awarded. Students may earn a maximum of 0.5 Service Learning credits per semester. Students may not transcript more than 2.0 Service Learning credits total.

CAREERREADY COLORADO CERTIFICATE

Students enrolled in a FutureForward at Bollman and Washington Square program have the opportunity to train and test for the CareerReady Colorado Certificate developed by ACT Work Keys. Students who complete the training and testing at the Silver Level or higher will receive 0.5 elective credits. This certificate verifies workplace competencies in three areas: Applied Math, Workplace Documents, and Graphic Literacy. The Work-Based Learning Coordinator facilitates training and testing. A test fee may apply.

ARTICULATION AGREEMENTS

Articulation Agreements have been established for some programs and continue to be maintained between FutureForward at Bollman and Washington Square, community colleges, 4-year colleges, and private post-secondary institutions. This allows students the opportunity to earn college credit(s). Please contact the counselors or registrars, or visit our website at futureforward.adams12.org for more information or program-specific questions about Articulation Agreements.

CONCURRENT ENROLLMENT

Concurrent Enrollment is designed to improve coordination between secondary and post-secondary institutions to create a seamless pathway for students to transition from one level to the next. A student is simultaneously enrolled in FutureForward at Bollman or Washington Square and an institute of higher-level education. Not all programs will be eligible for Concurrent Enrollment for the 2023-2024 school year. Please contact the registrars or counselors, or visit our website at futureforward.adams12.org for more information or program-specific questions about Concurrent Enrollment.

ACADEMIC COURSE OFFERINGS

Students **must** be enrolled in a FutureForward Career and Technical program to be eligible for enrollment in FutureForward academic courses.

<i>English 11 – American Lit/Comp</i>	<i>English 12 – Lit/Comp</i>
<i>College English 1021 – Freshman Composition (FRCC Guaranteed Transfer Course)</i>	<i>College English 1022 – Research Seminar (FRCC Guaranteed Transfer Course)</i>
<i>CP Anatomy and Physiology (does not include PE credit at FutureForward)</i>	

(BOLLMAN and WASHINGTON SQUARE English and CP Anatomy courses meet district graduation requirements.) Please consult with your counselor to verify which courses meet the NCAA Clearinghouse requirements before making final course selections.

Classes will be offered if there is sufficient enrollment.