



Welcome to  
Grade 4

The 4th Grade Team:

Ms. Allen – [LisaAllen@carrollk12.org](mailto:LisaAllen@carrollk12.org)

Mr. Koontz - [BrandonKoontz@carrollk12.org](mailto:BrandonKoontz@carrollk12.org)

Ms. Shanabarger –  
[MariaShanabarger@carrollk12.org](mailto:MariaShanabarger@carrollk12.org)

Ms. Spencer – [ShannonSpencer@carrollk12.org](mailto:ShannonSpencer@carrollk12.org)

Ms. Showman –  
[TammyShowman@carrollk12.org](mailto:TammyShowman@carrollk12.org)

# Reset, Restart, Refocus

---

“  
RESET,  
REFOCUS,  
RESTART.”

”

[cominguprosentheblog.com](http://cominguprosentheblog.com)

# Daily Schedule

---

8:05 – 8:35	Arrival
8:35 - 9:35	MOD 1
9:35 – 10:35	Fine Arts
10:35-11:45	MOD 1 ( Snack Break)
11:45- 1:00	MOD 2
1:00 – 2:00	Lunch/Recess
2:00 – 3:00	MOD 2
3:05	Dismissal



# Snack!



Fourth Grade has a late lunch. Due to this, we will be having a small snack directly after specials!

## Snack Is

Small

Easily cleaned up

Does not contain nuts

## Snack Is Not

Messy/Sticky

A Smorgasboard

No drinks please!

# HOME ACCESS Instructions



**Carroll County Public Schools**  
*Building the future*

Staff Links ▾



About

Student Services

Academics

Accountability

Operations

Board of Education

Curriculum and Instruction

ESOL

G&T/Advanced Academic Programs

Library Media

Special Education

Professional Learning

Student and Parent Resources

Service Learning

HOME > ACADEMICS > STUDENT AND PARENT RESOURCES

## Student and Parent Resources

Web Apps

Student Remote Login FAQs

Student Resources

Instructional Resources

Health & Wellness

Google Workspace Notice

This Form is for CCPS families reporting issues with the following student applications:

Eng

# HOME ACCESS Instructions



# HOME ACCESS Instructions



## Home Access Center

Welcome to Carroll County Public School's Home Access Center. To begin, please enter your **username** and **password**. Your username is the email address where you receive School Messenger communications from your school.

If this is the first time you are logging into Home Access Center or if you have already logged into the site and have forgotten your password, you will need to go through the 'Request/Forgot Password' process via the link below.

User Name

Password

# Student Access - School Email

- <http://office.com>

- User Name:

Their [schoolUN@STAR.carrollk12.org](mailto:schoolUN@STAR.carrollk12.org)

- Password:

Their School password



# LSE STAR Standards

---

- S – Safety
  - T – Taking Responsibility
  - A – Active Learner
  - R - Respect
- Students are expected to follow our STAR standards. STARBUCKS are given to students who demonstrate these standards.

# PBIS

---

## Positive Behavior Intervention Supports

- Linton Springs is a PBIS school
- Focus is on positive reinforcement
- School store and grade/classroom incentives
- STOP & THINK reflection sheet will be used as a reminder of our STAR standards

# 4<sup>th</sup> Grade Math Concepts

---

- ❖ Addition and Subtraction
- ❖ Multiplication and Division
- ❖ Fractions/Decimals
- ❖ Geometry and Patterns
- ❖ Multiplicative Comparisons and Measurement
- ❖ Multiplying Fractions
- ❖ Measurement Problem Solving



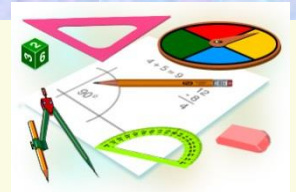

# What can you do to help in math?

- Continue to stress the importance of learning basic addition, subtraction, multiplication, and division facts.
- Share and involve your child in daily uses of math (cooking, traveling, shopping, allowance, telling time).
- Utilize the CCPS Website
- Encourage reasoning skills by asking questions like:
  - How do you know your answer is correct?
  - Show me how you solved the problem.
- Let your child know that real learning comes with struggle and experience.

# Math Resources

---

Refer to your child's *Math notebook* for resources and class notes

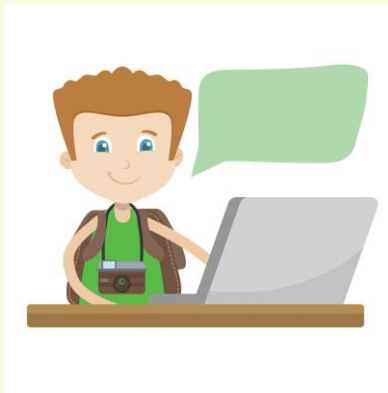
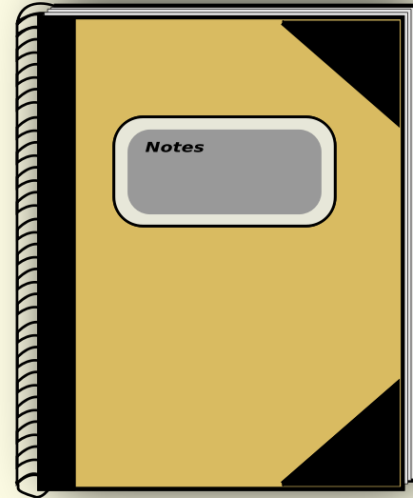

[Click here for Carroll County curriculum link](#)

# Science

- Ecosystems
- Energy
- Waves
- Earth System

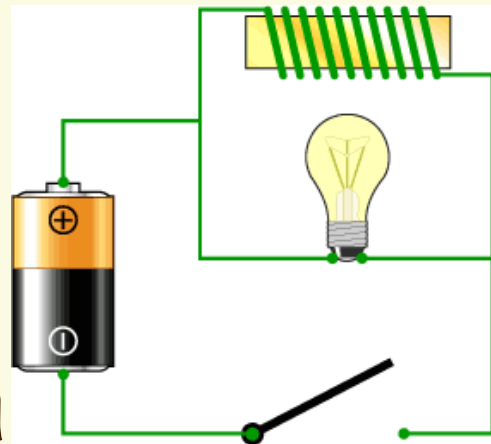

[Click here for Carroll County curriculum link](#)

# English Language Arts

---

*Reading* — Instruction is designed to foster higher-level thinking and reading strategies using both **literary** and **informational** text.

McGraw Hill - Wonders Anthology Series; Novel Study

We will be reading realistic fiction, poetry, historical fiction, non-fiction, mysteries, biographies, and fantasies throughout the school year.



# English Language Arts

---

*Writing* - We write for three purposes using a variety of formats:

1. Narrative - writing about a real or imagined experience
2. Opinion – including facts and details in a reasoned, logical argument
3. Informative - writing to inform someone about a topic



Writing will be cross-curricular. Students will be expected to write in social studies, math, and science classes.



# English Language Arts

*Vocabulary*- Explicit instruction using McGraw Hill anthology

*Word Study*- Instruction about “how English works.” Students will learn word patterns and apply them in reading and writing.



*Grammar*- Explicit instruction



# What can you do to help in ELA?

---

- Read to and with your child every day.
- Visit the library regularly to allow choice of a variety of age-appropriate books, magazines, and newspapers.
- If your child is reading and comes to an unknown word, prompt him/her with, “What would make sense there?”
- Provide real-life writing opportunities (letters to friends or relatives, thank-you notes, scrapbooks, diaries).
- Spend time talking with and listening to your child tell about daily experiences. These could be written into a journal or scrapbook.
- Let your child “catch you” reading and writing.

# Social Studies (New This Year)

---

- Geographic & Historical Thinking
- Worlds Collide (1450-1650)
- Resistance, Colonization & European Expansion (1500-1750)
- American Revolution (Novel Study – The Fighting Ground)



# Grading

---

Please check online grades through Home Access link weekly in order to monitor your child's progress.

- ELA
  - Grades divided between reading and writing
  - Reading tests, reading classwork, vocabulary quizzes, writing assignments, grammar
  - Social Studies
    - Quiz, test, projects, writing
- Math
  - Grades divided between quizzes, tests, classwork
  - Science
    - Design challenges, STEM notebook, writing

# Home-School Communication

---

- Email / Phone calls
- Email updates will be sent home
- Conference Nights 10/17, 1/25 (Teacher request),  
11/15, 12/7 (Parent request)
- Home Access Center



# Homework

---

- ❖ Will be assigned Monday – Thursday
- ❖ Tech Tuesdays – Student laptops go home  
To Begin September 19
- ❖ Assignments should take no more than 40 minutes total to complete, in addition to the reading. If an assignment was difficult, please write a note in the agenda book.
- ❖ Read 20 minutes every night.

# 4th Grade Special Events

---

- Band/Choir – More information to come from Mrs. McCusker & Mr. Collins



**COMING SOON**

This Photo by Unknown Author is licensed under CC BY

Thank you for coming!

**Education is the key to unlock  
the golden door of freedom.**

— *George Washington Carver*

