

DeMATHA CATHOLIC HIGH SCHOOL PARENT AND STUDENT HANDBOOK 2023-2024

This school agenda belongs to:

Name: _____

Address: _____

City: _____

Phone: _____

ID # _____ Homeroom _____

The handbook does not represent a contract and is subject to change at the School's discretion.

DeMatha Catholic High School admits students of any race, color, national and ethnic origin to all the rights, privileges, programs, and activities generally accorded or made available to students at the school. DeMatha does not discriminate on the basis of race, color, national and ethnic origin in administration of educational policies, loan programs, and athletic and other school-administered programs. DeMatha, to the extent required by Title IX, does not discriminate against any applicant/employee because of sex, nor does it discriminate against any student because of sex in any educational program or activity.

The information in this book was the best available at press time. Watch for additional information and changes.



powered by  sdi innovations

No part of this publication may be reproduced, stored in a retrieval system, or transmitted in any form without getting prior written permission of the publisher.

© 2023. SDI Innovations. All Rights Reserved.

2880 OLD US HIGHWAY 231 S, LAFAYETTE IN 47909-2414 • 765.471.8883
www.schooldatebooks.com • sdi@schooldatebooks.com



DeMATHA CATHOLIC HIGH SCHOOL



Order of the Most Holy Trinity and of the Captives

UNITED STATES DEPARTMENT OF EDUCATION
TWICE RECOGNIZED SCHOOL OF EXCELLENCE

Office of The President

Dear Parents and Students,

DeMatha is very happy to welcome to the campus the newest members of our family, the Class of 2027, as they begin their journey within the DeMatha Tradition. This has been a very wise choice made by students and parents. In addition, we also welcome back the returning students to our campus. It is my hope that the summer gave us some time to relax and then to look forward to being together for another successful academic year.

We are now in our 77th year of quality Catholic education at DeMatha, and as this *Student Handbook* goes to print, we are hoping that the county construction permits will have been issued, and we can now see the state-of-the-art Cross Center for Engineering, Arts and Robotics rising from the earth. The legendary Fotos Center has been removed, and we are anxious to get this newest addition to our campus buildings up and running. Exciting times are still on the horizon!

We ask all families to become familiar with the contents of the *Student Handbook*. Every organization needs a clear set of expectations, so that everyone is working toward the same goal of shaping Faith-Filled Gentlemen and Scholars. The more knowledge we can share and the more investing of our energies into a successful school year we can pledge, the more enjoyable and productive this academic year will be.

I thank all the families for entrusting us with the real treasure of your life, your son or grandson. We pledge to work with you and to continue creating a safe and welcoming environment for all people to enjoy what it means to be part of the DeMatha Legacy, which is a valued Trinitarian tradition.

Blessings!

Fr. James, O.S.S.T.
President



4313 Madison Street, Hyattsville, Maryland 20781
240.764.2200 www.dematha.org Fax 240.764.2275





DeMATHA CATHOLIC HIGH SCHOOL



Order of the Most Holy Trinity and of the Captives

UNITED STATES DEPARTMENT OF EDUCATION
TWICE RECOGNIZED SCHOOL OF EXCELLENCE

Office of the Principal

2023-2024

Dear Student:

Thank you for being part of a tradition that stretches back more than 75 years and has produced thousands of Faith-Filled Gentlemen and Scholars. You are being asked to extend and strengthen this tradition.

To assist you in this task it is important that you and your parents become fully acquainted with the policies, programs, procedures and services available at DeMatha. This handbook is a terrific resource and will provide you with information that should become common knowledge to you and your parents. All students and parents are responsible for knowing and adhering to the policies and procedures presented herein.

We are looking forward to the upcoming school year with enthusiasm and we encourage all students and their families to join with us in making this year a happy, productive, and fulfilling one.

Sincerely,

Dr. Daniel J. McMahon, '76 Ph.D.
Principal

4313 Madison Street, Hyattsville, Maryland 20781
240.764.2202 www.dematha.org Fax 240.764.2275

TABLE OF CONTENTS

<p>DeMatha Catholic High School Parent and Student Handbook 2023-2024..... 1</p> <p>Handbook Modifications.....23</p> <p>Use of School Name and Logo.....23</p> <p>Student Images.....23</p> <p>General Information 24</p> <p>School Governance and Administration 25</p> <p>DeMatha Catholic High School</p> <p style="padding-left: 20px;">Mission Statement.....25</p> <p style="padding-left: 20px;">School Philosophy25</p> <p style="padding-left: 20px;">DeMatha Man26</p> <p>History of DeMatha..... 26</p> <p style="padding-left: 20px;">The Trinitarians29</p> <p style="padding-left: 20px;">Finances30</p> <p style="padding-left: 20px;">Office Hours31</p> <p style="padding-left: 20px;">School Hours32</p> <p style="padding-left: 20px;">Weekly Bulletin32</p> <p style="padding-left: 20px;">Remind.....32</p> <p style="padding-left: 20px;">Parent Alert.....32</p> <p style="padding-left: 20px;">DM Stag Store32</p> <p style="padding-left: 20px;">Change of Address32</p> <p style="padding-left: 20px;">Student ID and ID Cards.....32</p> <p style="padding-left: 20px;">Fundraising Drives32</p> <p style="padding-left: 20px;">Emergency Health Care.....33</p> <p style="padding-left: 20px;">Reporting of Child Abuse And/Or Neglect.....33</p> <p style="padding-left: 20px;">Search of Student Lockers, Bookbags,</p> <p style="padding-left: 40px;">Clothing and Automobiles33</p> <p style="padding-left: 20px;">Use of Public Law Enforcement Officials by the School33</p> <p style="padding-left: 20px;">Athletic Injuries.....33</p> <p style="padding-left: 20px;">Student Health Records.....33</p> <p style="padding-left: 20px;">Participation on Interscholastic Teams.....33</p> <p style="padding-left: 20px;">Concussion Testing.....34</p> <p style="padding-left: 20px;">Field Trips34</p> <p style="padding-left: 20px;">Lost and Found34</p> <p style="padding-left: 20px;">Transportation to and from School Functions.....34</p> <p style="padding-left: 20px;">Re-Enrollment.....34</p> <p style="padding-left: 20px;">Snow Days or Other Emergencies.....34</p> <p style="padding-left: 20px;">Snow Policy for Bus Transportation34</p> <p style="padding-left: 20px;">Extended Forced School Closings.....35</p> <p style="padding-left: 20px;">Messages for Students35</p> <p style="padding-left: 20px;">Shuttle to College Park Metro Station.....35</p> <p style="padding-left: 20px;">Extra-Curricular Activities35</p> <p style="padding-left: 20px;">Awards Presented at Baccalaureate And/Or Graduation36</p> <p style="padding-left: 20px;">The National Honor Society, Valois Chapter.....36</p> <p>Campus Ministry Office (Cmo)37</p> <p style="padding-left: 20px;">Dr. Daniel J. McMahon Library.....40</p> <p style="padding-left: 20px;">Parent and Booster Organizations.....40</p>	<p>Academic Information..... 42</p> <p style="padding-left: 20px;">Academic Program43</p> <p style="padding-left: 20px;">Suggestions for Improving Study Habits.....43</p> <p style="padding-left: 20px;">The Earning of Credit Units.....44</p> <p style="padding-left: 20px;">Selection of Teachers.....44</p> <p style="padding-left: 20px;">Graduation Requirements.....44</p> <p style="padding-left: 20px;">Sample Program45</p> <p style="padding-left: 20px;">Program of Studies46</p> <p style="padding-left: 20px;">Grading System50</p> <p style="padding-left: 20px;">Quality Points Assigned Per Semester50</p> <p style="padding-left: 20px;">Rank in Class.....50</p> <p style="padding-left: 20px;">Academic Recognition50</p> <p style="padding-left: 20px;">Promotion.....50</p> <p style="padding-left: 20px;">Diplomas with Distinction.....51</p> <p style="padding-left: 20px;">Failing Grades for Seniors and Graduation51</p> <p style="padding-left: 20px;">Academic Quarters51</p> <p style="padding-left: 20px;">Report Cards.....51</p> <p style="padding-left: 20px;">Grade Changes and Incomplete Grades51</p> <p style="padding-left: 20px;">Classroom Visits by Parents.....51</p> <p style="padding-left: 20px;">Electronic Recording by Parents.....51</p> <p style="padding-left: 20px;">Academic Probation and</p> <p style="padding-left: 40px;">Extracurricular Ineligibility52</p> <p style="padding-left: 20px;">Athletic Extracurricular Activities52</p> <p style="padding-left: 20px;">Fall Sports Season.....52</p> <p style="padding-left: 20px;">Winter Sports Season.....53</p> <p style="padding-left: 20px;">Spring Sports Season.....53</p> <p style="padding-left: 20px;">Hockey.....53</p> <p style="padding-left: 20px;">Non-Athletic Extracurricular Activities54</p> <p style="padding-left: 20px;">Failing Grades.....54</p> <p style="padding-left: 20px;">Teacher Selection54</p> <p style="padding-left: 20px;">Sequence Courses54</p> <p style="padding-left: 20px;">Summer School54</p> <p style="padding-left: 20px;">Dropping Courses55</p> <p style="padding-left: 20px;">Transfer Procedures55</p> <p style="padding-left: 20px;">School Records.....55</p> <p style="padding-left: 20px;">Significant Academic Assessment Schedule55</p> <p style="padding-left: 20px;">Retake Policy for Major Tests55</p> <p style="padding-left: 20px;">Final Examinations.....56</p> <p style="padding-left: 20px;">Academic Awards Night56</p> <p style="padding-left: 20px;">Materials Fee56</p> <p>The Counseling Center 57</p> <p>The Counseling Center 58</p> <p style="padding-left: 20px;">Student Record Keeping.....58</p> <p style="padding-left: 20px;">Disclosure Policy.....59</p> <p style="padding-left: 20px;">Confidential Reporting Box59</p> <p>Student Procedures And Regulations..... 60</p> <p style="padding-left: 20px;">Student Procedures and Regulations61</p> <p>Appendices 75</p> <p>Appendix A..... 76</p> <p>Drug and Alcohol Abuse..... 76</p>
--	---

Appendix B.....	76	Appendix K.....	93
School Regulations with Respect to Academic Dishonesty.....	76	Safety Plans at DeMatha Catholic High School ...	93
Appendix C.....	78	Parent Response to Emergency Situation at DeMatha	93
Parent Permission Form for Field Trips and Release of Liability (Sample)	78	How to Respond When an Active Shooter is in Your Vicinity	93
Appendix C Continued.....	79	Fire.....	94
DeMatha Catholic High School Field Trip Information Sheet (Sample)	79	Evacuation / Relocation	95
Appendix D.....	80	Teachers	95
Statement Concerning the Reporting of Child Abuse and Neglect.....	80	Earthquake	95
Appendix E.....	81	During an Earthquake.....	95
DeMatha Catholic High School Student Technology Agreement	81	After an Earthquake.....	95
Appendix F.....	84	Intruder / Hostage.....	96
Appendix G	88	Intruder: "An Unauthorized Person Who Enters School Property."	96
Sample Transcript	88	If Intruder Refuses to Leave.....	96
Appendix H.....	89	Hostage Situation.....	96
DeMatha Catholic High School (Sample - Parking Permit)	89	Severe Storm	96
Appendix I.....	90	Severe Wind, Snow, Rain, Hail, Thunderstorms, Tornadoes, Hurricanes & Flash Floods	96
Appendix J.....	91	Appendix L.....	97
Family Educational Rights and Privacy Act.....	91	(Student-Athlete Name, Image or Likeness)	
		Nil Policy	97



The State of Maryland requires the following statement in the Student Handbook:

“It is the policy of the State of Maryland that all public and publicly funded schools and school programs operate in compliance with:

- (1) Title VI of the Federal Civil Rights Act of 1964; and
- (2) Title 26, Subtitle 7 of the Education Article of the Maryland Code, which states that public and publicly funded schools and programs may not:
 - (i) Discriminate against a current student, a prospective student, or the parent or guardian of a current or prospective student on the basis of race, ethnicity, color, religion, sex, age, national origin, marital status, sexual orientation, gender identity, or disability;
 - (ii) Refuse enrollment of a prospective student, expel a current student, or withhold privileges from a current student, a prospective student, or the parent or guardian of a current or prospective student because of an individual’s race, ethnicity, color, religion, sex, age, national origin, marital status, sexual orientation, gender identity, or disability; or
 - (iii) Discipline, invoke a penalty against, or take any other retaliatory action against a student or parent or guardian of a student who files a complaint alleging that the program or school discriminated against the student, regardless of the outcome of the complaint.”

The State of Maryland does not require a nonpublic school that is religiously affiliated to enroll, retain, or extend privileges to a student or prospective student who does not meet the usual and regular qualifications, requirements, and standards of the program or school or to adopt any rule, regulation, or policy that conflicts with the program or school’s religious or moral teachings provided that the denial, rule, regulation, or policy is not based on discrimination on the grounds of race, ethnicity, color, religion, sex, age, national origin, marital status, sexual orientation, gender identity, or disability. We will always teach and act consistent with the tenets of the Catholic Church.

DeMatha Catholic High School admits students of any race, color, national and ethnic origin to all the rights, privileges, programs, and activities generally accorded or made available to students at the school.

DeMatha does not discriminate on the basis of race, color, national and ethnic origin in administration of educational policies, loan programs, and athletic and other school-administered programs. DeMatha, to the extent required by Title IX, does not discriminate against any applicant/employee because of sex, nor does it discriminate against any student because of sex in any educational program or activity.

DeMATHA CATHOLIC HIGH SCHOOL

4313 MADISON STREET
HYATTSVILLE, MD 20781

240-764-2200 Main Number
240-764-2275 Fax Number
Web Site: www.dematha.org

Fr. James R. Day, O.S.S.T.
President

Fr. Albert Anuszewski, O.S.S.T.
Director of Trinitarian Mission

Daniel J. McMahon, '76 Ph.D.
Principal

William C. Clark
Assistant Principal

Sam Haller
Assistant Principal for Faculty Formation and Professional Development

Shaka D. Dickerson, '03
Dean of Students

Anne N. Metz
Finance Director

Maureen Mann Ritz, MA., L.C.P.C.
Director of Guidance and Counseling



Thomas J. Krawczewicz, '81
Director of Educational Resources

**CALENDAR
BELL SCHEDULE
AND
CLASS ROTATION**

July 2023

Sun	Mon	Tue	Wed	Thu	Fri	Sat
						1
2	3	4 School/Offices Closed Independence Day	5 Summer Band	6 Summer Band	7	8
9	10	11 Summer Band	12	13 Summer Prep Session Ends Summer Band	14	15
16	17	18 Summer Band	19	20 Summer HS Ends Summer Band	21	22
23	24	25 Summer Band	26	27 Summer Band	28 Freshmen Schedules Mailed	29 Uniform Measurements
30	31					

August 2023

Sun	Mon	Tue	Wed	Thu	Fri	Sat
		1	2	3	4	5
6 Transfer & Freshman Mothers' Welcome Brunch 1:00pm-3:00pm	7 All A.T.S. (Physicals) Info Due for Fall Sports	8 New Teacher Orientation	9 Course Changes 9:00am-1:00pm 9th Grade ONLY	10 Course Changes 9:00am-1:00pm ALL GRADES	11	12 DPO Book Swap 8:00am-12:00pm Uniform Measurements Ring Measurements All Fall Sports Begin
13	14	15 New Teacher Orientation	16 New Teacher Orientation  Senior Pictures	17 Administrative Retreat  Senior Pictures	18 Administrative Retreat  Senior Pictures	19
20 New Faculty/Staff Mentor Dinner	21 Faculty Meetings	22 Faculty Meetings Transfer Parents Cookout 5:30pm-7:00pm	23 Faculty Meetings	24 Opening Day 1 Freshmen Experience Freshmen Parent Coffee 8am-9am	25 Opening Day 2 Freshmen Experience Transfer Opening Day	26 SAT Date
27	28 Opening Day Sophomores, Juniors, Seniors Freshmen - No Classes Sophomore Parent Coffee 8am-9am	29 Regular Classes All Students	30	31 Junior Parent Coffee 8am-9am Ring Measurements 7:30am-9:00am Summer Service Hours Due		

September 2023

Sun	Mon	Tue	Wed	Thu	Fri	Sat
					1	2
	4	5	6	7	8	9
	NO CLASSES <i>Labor Day</i>	Back-to-School Night - 9th Grade ONLY 7:00pm			Opening School Liturgy	ACT Men of DM Cookout 12:00pm-2:00pm Voices of DeMattha Retreat
10	11	12	13	14	15	16
		Instrumental Music Parent Meeting 7:30pm	Chorus Parent Meeting 7:00pm	Senior Parent Meeting 7:00pm VIRTUAL Back-to-School Night ALL GRADES	Senior Pictures Last day to Drop/Add Courses Bake Sale - Freshmen	
17	18	19	20	21	22	23
		Stag-for-a-Day Visits Begin Parent Organization Meeting (Uniform Measurements)		Tag Day for <i>Walk-A-Thon</i> Admissions Information Night (Incoming students) 7:00pm	NHS Candidate Packet Available Ring Measurements	Alumni Reunions
24	25	26	27	28	29	30
				Walk-A-Thon	Faculty/Staff Retreat NO CLASSES	Senior Booster Crab Feast 4:00pm-7:00pm Service Hours Due

October 2023

Sun	Mon	Tue	Wed	Thu	Fri	Sat	
1	2	3	4	5	6	7	
			HOME COMING / SPIRIT WEEK			Homecoming Game Vs Gonzaga	SAT Date Homecoming Dance
8	9	10	11	12	13	14	
	NO CLASSES <i>Columbus Day</i>		Standardized Testing 10th & 11th Grades Admissions Information Night 7:30pm.			Kaleidoscope Concert 6:00pm	
15	16	17	18	19	20	21	
	Full Uniform Required			Middle School Science Teacher Workshop 9:00am - 2:00pm	Ring Measurements Order Deadline	Reunion Class of '88	
22	23	24	25	26	27	28	
	Yearbook Pictures 			End of Qtr 1 NHS Candidate Packet Due	Cyber Day HSPA Professional Day	ACT	
29	30	31					
		Service Hours Due					

November 2023

Sun	Mon	Tue	Wed	Thu	Fri	Sat
			1 All Saints Day Mass Winter sports physicals/ATS due Food Drive Begins	2 Feast of All Souls Tag Day - Food Drive	3	4 SAT Date
5 Open House 10:30am-1:30pm	6 Senior Pictures	7 Senior Pictures	8 Winter Sports Begin	9 Parent-Teacher Conferences 4pm-7pm	10 NO CLASSES Faculty Meeting	11 Veterans' Day
12	13	14	15	16 College Process (Jrs.) Meeting 7pm	17 Food Drive Ends Bake Sale - Sophomore DM Players Fall Play	18 Music Dept. 5K DM Players Fall Play
19 DM Players Fall Play	20	21 Bring-A-Pie Day	22 Alumni Slag Night	23 Thanksgiving Day	24	25
26 Advent Begins	27	SENIOR OVERNIGHT RETREAT		THANKSGIVING HOLIDAY		
		28 Toy Drive Begins	29	30 Service Hours Due		

December 2023

Sun	Mon	Tue	Wed	Thu	Fri	Sat
3	4	5	6	7	8	9
	Christmas Tree Lighting			Fall Concert 7:00pm CBI/PEI, CS, CB, CBI	Feast of the Immaculate Conception (Mass) Toy Drive Ends	HSPT WAMTC Band Academic Competition Festival SAT Date
10	11	12	13	14	15	16
		Fall Concert 7:00pm APE/PE II/Sym. Band	Early Dismissal Faculty/Staff Christmas Luncheon Fall Concert 7:00pm Convo Center Jazz and Choruses	College Process Meeting (Fr.) 7:00pm Fall Concert 7:00pm Wind Ensemble and Symphonia	Mass - St. John de Matha Day	Faculty/Staff Family Open House
17	18	19	20	21	22	23
Actual Feast Day of St. John de Matha						
24	25	26	27	28	29	30
	Christmas <i>Birth of Our Savior</i>	CHRISTMAS HOLIDAY		CHRISTMAS HOLIDAY		
31						
Service Hours Due						

January 2024

Sun	Mon	Tue	Wed	Thu	Fri	Sat
	1	2	3	4	5	6
	HAPPY NEW YEAR	Classes Resume				
7	8	9	10	11	12	13
			NHS Induction Ceremony		End of Qtr 2	
14	15	16	17	18	19	20
	No Classes MLK Day				March for Life	
			DEMATHA EXPERIENCE			
21	22	23	24	25	26	27
				Parent-Teacher Conferences 4:00pm-7:00pm	NO CLASSES Faculty Meeting	
28	29	30	31			
		Freshman Parent Coffee 8:15am-9:00am	Sophomore Parent Coffee 8:15am-9:00am			
			Service Hours Die			

February 2024

Sun	Mon	Tue	Wed	Thu	Fri	Sat
				1 Junior Parent Coffee 8:15am-9:00am BSU Tag Day	2 Last day to Add/Drop Courses	3
4 Academic Challenge	5	6	7 Junior Retreat Cyber Day 9th, 10th & 12th	8	9 Bake Sale - Juniors	10 ACT DPO - Bull Roast
11	12 Cyber Day	13 All ACTS (Physicals) Info/Due for Spring Sports DMJI Tag Day	14 Ash Wednesday	15 Re-Enrollment Due	16	17
18	19 NO CLASSES President's Day	20 Spring Sports Begin	21	22 College Process Meeting (frs.) 7:00pm	23	24
25	26	27	28	29 Service Hours Due		

March 2024

Sun	Mon	Tue	Wed	Thu	Fri	Sat
3	4 Senior Service Hours Due	5	6 Honor Info. Night 7:00pm Early Dismissal	7	8 New Students Enrollment Due	9 SAT Date
10	11	12	13 Sophomore Retreat / Conversation Early Dismissal	14 Senior Service Interviews	15 End of 3rd Qtr Muffin Madness NHS Tag Day Senior Service Interviews	16
17 St. Patrick's Day	18	19 College Process Meeting (Jrs.) 7:00pm	20 Senior Service Reflection Papers Due	21 MANDATORY Senior Parent Meeting	22	23
24 Palm Sunday	25	26 Jazz Band/ Percussion Ensemble Concert (Convocation Gift)	27	28	29 Good Friday	30 Holy Saturday
31 EASTER EASTER HOLIDAY Service Hours Due				SPRING BREAK / EASTER HOLIDAY		

April 2024

Sun	Mon	Tue	Wed	Thu	Fri	Sat
1	2 Easter Monday	3	4	5	6	
	EASTER HOLIDAY					
7	8 Classes Resume Senior (ONLY) Spring Uniform	9 Music Trip Parent Meeting	10 Music Trip Parent Meeting	11	12	13 ACT
14	15	16	17	18	19	20
				MUSIC TRIP		
21	22 New Students Welcome 7:00pm	23	24 Early Dismissal Academic Award Night	25	26 DM Players Spring Play	27 DM Players Spring Play
28	29 DM Players Spring Play	30 Service Hours Due				

May 2024

Sun	Mon	Tue	Wed	Thu	Fri	Sat
			1	2	3	4
				Spring Concert 7:00pm CB/CB II/CB I/PE I/CS	Jr / Sr PROM No Classes for Seniors Early Dismissal	SAT Date
5	6	7	8	9	10	11
Mother/Son Luncheon			Bagel Day Spring Concert 7:00pm APE/PEII/Sym. Band			Placement Testing 9:00am Uniform Measurements
			AP Exams			
12	13	14	15	16	17	18
Mother's Day	Underclassmen Spring Uniform	Spring Concert 7:00pm Wind Ensemble and Sinfonia	DPO Social/Raffle	Graduation Practice 10:30am Convo. Cntr Senior/Faculty Picnic		Music Award Night
			AP Exams			
19	20	21	22	23	24	25
						End of School Mass
			AP Exams			
			SENIOR COLLEGE PREP			Underclass Service Hours Due
26	27	28	29	30	31	
	NO CLASSES <i>Memorial Day</i>					
			UN D E R C L A S S E X A M S			
			LOCKERS CLEAN OUT			

June 2024

Sun	Mon	Tue	Wed	Thu	Fri	Sat
						1 SAT Date
2	3	4 Faculty Meetings	5 Graduation Practice @ Shrine 11:00am Baccalaureate Mass @ 4:00pm	6 Faculty Meetings	7 Graduation Nat'l Shrine 9:00am	8 ACT
9	10	11	12	13	14	15 New Student Placement Exam 9:00am Uniform Measurements
16 Father's Day	17 Summer Prep Session Begins DMLI	18 DMLI	19 NO CLASSES <i>Juareceith</i> DMLI - Off Campus	20 Summer HS Begins	21	22
23	24	25	26	27	28	29
30						

July 2024

Sun	Mon	Tue	Wed	Thu	Fri	Sat
	1	2	3	4 Independence Day School/Office Closed	5	6
7	8	9 Summer Band	10	11 Summer Prep Session Ends Summer Band	12	13 ACT
14	15 Health Forms Due for ALL Incoming Students (Transfer and Freshmen)	16 Summer Band	17	18 Summer HS Ends Summer Band	19	20
21	22	23 Summer Band	24	25 Summer Band	26	27
28	29	30	31			

Bell Schedules 2023-24

DAILY SCHEDULE

Class 1	8:15	9:20
Class 2	9:25	10:25
Homeroom	10:30	11:00
A Lunch	11:05	11:45
Class 3-A	11:45	12:45
Class 3-B	11:05	12:05
B Lunch	12:05	12:45
Class 4	12:50	1:50
Class 5	1:55	2:55

ASSEMBLY SCHEDULE

Class 1	8:15	9:05
Assembly	9:10	10:35
A Lunch	10:40	11:20
Class 2-A	11:20	12:10
Class 2-B	10:40	11:30
B Lunch	11:30	12:10
Class 3	12:15	1:05
Class 4	1:10	2:00
Class 5	2:05	2:55

2:00 DISMISSAL

Class 1	8:15	9:05
Class 2	9:10	10:00
Homeroom	10:05	10:35
A Lunch	10:40	11:20
Class 3-A	11:20	12:10
Class 3-B	10:40	11:30
B Lunch	11:30	12:10
Class 4	12:15	1:05
Class 5	1:10	2:00

2-HOUR DELAYED OPENING

Class 1	10:15	11:00
A Lunch / Class 2-B	11:05	11:50
B Lunch / Class 2-A	11:55	12:40
Class 3	12:45	1:25
Class 4	1:30	2:10
Class 5	2:15	2:55

HALF-DAY DISMISSAL

Class 1	8:15	9:00
Class 2	9:05	9:45
Class 3	9:50	10:30
A Lunch / Class 4-B	10:35	11:20
B Lunch / Class 4-A	11:25	12:10
Class 5	12:15	12:55

HANDBOOK MODIFICATIONS

The school reserves the right to change and/or modify the contents of this handbook at any time.

USE OF SCHOOL NAME AND LOGO

"DeMatha Catholic High School," "DeMatha," "DeMatha Stags," the DeMatha Catholic High School seal, the red & blue cross, and the antlers with the red and blue cross are the property of DeMatha Catholic High School and may not be used without permission.

DeMatha Catholic High School prohibits the use of its name and/or logo in any format including but not limited to Internet sites, Web pages, home pages, blogs, etc. without express written permission from the school.

STUDENT IMAGES

Parents/guardians are advised that photographs or videotape of students may be used in publications, Web sites or others materials produced from time to time by or on behalf of DeMatha Catholic High School. (An individual student would not be identified by name; however, without prior written consent from such individual's parent/guardian). Parents/guardians who do not wish their son to be photographed or filmed should so notify the Principal in writing. Please note that the School has no control over the use of photographs or film taken by media that may be covering the event in which your son participates or attends.



GENERAL INFORMATION

SCHOOL GOVERNANCE AND ADMINISTRATION

Board Class A Members: The Class A Members of the DeMatha Corporation shall be the Trinitarians' Minister Provincial and members of the Trinitarians' Provincial Council. Their duties include amending the Articles of Incorporation or by-laws and controlling the strategic decisions of the school and its mission to provide quality Catholic education.

Board Class B Members: The Class B Members are from three to five Trinitarians who foster the mission and general philosophy under which the DeMatha Corporation will function. They will also ensure and make any determination whether the policies and procedures of the School comply with Roman Catholic and Trinitarian principles, teachings and doctrines.

Board of Directors: These twelve to twenty-four individuals manage the business affairs of the corporation by developing, implementing and monitoring short and long-term plans in keeping with the School's mission, while maintaining and advancing the School's position and image in relationship with the Trinitarians and the Archdiocese of Washington and the local community. The four officers of the corporation (President, Vice-President, Secretary and Treasurer) are part of this leadership team.

President: The president is the chief executive/administrative officer of the School in furtherance of the School's mission and will carry out all of the policies established by the Board of Directors. The President will also supervise the development of short and long range objectives and plans of the Board of Directors.

Principal: The Principal is responsible for the day-to-day operations of the School and works closely with the President in furthering the mission of the School, as well as ensuring the proper implementation of personnel policies and practices for the School.

DeMATHA CATHOLIC HIGH SCHOOL MISSION STATEMENT

DeMatha Catholic High School is a college preparatory institution dedicated to educating young men in the Trinitarian tradition. DeMatha's historic and ongoing mission is to serve students of differing abilities, interests, and backgrounds from the culturally rich and diverse greater Washington Metropolitan area.

Faculty and staff work to help young men develop a way of life characterized by attention to scholarship, dedication to moral principles, devotion to hard work, and the awareness of the need to serve others. Through a broad-based and rigorous curriculum, numerous opportunities for spiritual growth, a wide range of co-curricular opportunities, and a comprehensive service program, DeMatha cultivates a respect for other people that finds its most complete expression in students who become Faith-Filled Gentlemen and Scholars.

SCHOOL PHILOSOPHY

Statement of Purpose and Objectives:

DeMatha Catholic High School offers to young men in the Washington area a college preparatory program in which faith and knowledge complement each other. A faculty and staff composed of Trinitarian religious and dedicated laymen and laywomen provide a program of instruction that serves young men of varied intellectual, religious, cultural and economic backgrounds. The Trinitarian charism that informs DeMatha asks that students become "men of action, men of prayer."

The DeMatha student develops spiritually and morally in a community where faith seeks understanding and is lived in service to neighbor. Religious instruction provides the student with an intellectual appreciation for the Judeo-Christian tradition as well as an ecumenical respect for diversity in religious expression and creed. Intellectual growth occurs within the moral framework and is achieved through a broad-based curriculum that incorporates appropriate pedagogical techniques and technological innovations.

A rich co-curricular program provides an opportunity for informal and formal instruction where students witness and understand the sound principles for human rights and the corresponding need for self-discipline. By experiencing healthy competition and sportsmanlike behavior involved in physical education and athletic events, students grow toward physical and social maturity.

DeMatha's administration and faculty are engaged in a continuous program of self-study to ensure the highest quality of educational experience is offered to our students each year. Yet the overall goal of a DeMatha education remains the same: to produce Faith-Filled Gentlemen and Scholars.

DeMATHA MAN

The DeMatha student is a man with pride in himself as a faith-filled gentleman and scholar and as a member of the community. He represents himself and his family, as well as classmates, his teachers, his coaches, the alumni and the Trinitarian Order. As our school grows and prospers, he will be entrusted with carrying forward the tradition of excellence that he has inherited. He shall be a leader whose commitment and discipline will show him to be a man of honor and integrity.

A DeMatha student sets goals for himself as a scholar, a teammate, a classmate and a man. To attain these goals, he bases his life on the principles of hard work, sacrifice, determination, service and selflessness. These ideals will help him achieve a level of excellence that will not be matched and that will earn him respect as an individual.

A DeMatha student is a man of prayer and a man of action who accepts readily the challenges of the world. He takes responsibility for himself and others. He always has his priorities in the proper order. He respects those who have come before him, is devoted to those who are with him now, and is conscious of those who will follow him in the future. He is courageous in the face of adversity. He is humble before the presence of God. He is steadfast in his service to others.

He is a Faith-Filled Gentleman and Scholar.

HISTORY OF DeMATHA

DeMatha Catholic High School was opened in Hyattsville, Maryland, a suburb of the Washington, D.C. metropolitan area, on September 9, 1946, by the priests of the Immaculate Heart of Mary Province of the Order of the Most Holy Trinity and of the Captives (Trinitarians), under the direction of the Very Rev. E. Cyprian Nusca, Provincial, Very Rev. Michael Nardone, Superior and first Principal, and Rev. Paul Donovan, Registrar and Dean.

The primary purpose of the school's founders was to furnish high school education for young men interested in preparing for the priesthood in the Order of the Most Holy Trinity. Accordingly, the initial program planned was strictly college preparatory.

However, as soon as word of the foundation circulated, Catholic parents in the Hyattsville, Greenbelt, Berwyn, and Mount Rainier areas requested permission to enroll their sons. In 1945, Catholic high school facilities for boys were limited to an even greater degree than at present.

Sensing an opportunity to offer service to the Archdiocese of Washington and its Catholic population, the superiors of the American province of the Order of the Most Holy Trinity and of the Captives agreed to accept a limited number of lay students. At that time, no plans for building or maintaining a separate school building were extant. A program of college preparatory subjects suited to the needs of the seminarians and carefully selected lay students to be held in the existing monastery facilities was all that was planned.

To ensure that the proper curriculum be offered and proper academic standards be maintained, officials of the newly formed school conferred with the Registrar of the Catholic University of America, Miss Catherine Rich, and the then Secretary General, Dr. Roy Deferrari, for advice and guidance. Needless to say, both Miss Rich and Dr. Deferrari were encouraging and helpful. Officials of the State Department for Education in Baltimore, Maryland, were questioned, concerning state requirements for the erection of a state-approved, non-public school and the necessary steps were taken to meet the state requirements. DeMatha was placed on the list of state-approved non-public schools in 1954.

The limited monastery facilities soon proved inadequate and a large six-car garage located behind the monastery building was pressed into service. One large classroom, office space and lavatory facilities were built in the first-floor area and large classrooms were improvised on the second floor. The resulting structure was far from ornate but provided the time-approved essentials for education: classrooms, desks and blackboards, adequate heat and light and dedicated teachers. The building earned the affectionate title, "Fort Necessity," and the name was apt. The Trinitarians had planned a small private academy for the education of small classes of minor seminarians; they found themselves shouldering the responsibilities of a rapidly expanding full-fledged high school.

As enrollment increased and the real interest of area parents became more evident, the superiors of the American Province decided to erect a separate building specifically planned as a secondary school. Because it was to be a strictly private enterprise without benefit of funds, either secular or ecclesiastical, the building design was strictly utilitarian. No money was available for frills, ornamentation, or ostentation. Construction was begun in 1949, and in January 1950, classes were held for the first time in the new building that featured a large gymnasium-auditorium, cafeteria, chapel, library, laboratory, and classrooms. The third floor, designed to contain six classrooms and two offices, was left unfinished until the following year.

In 1959 a new building program resulted in the addition of six classrooms: two new laboratories, one a biology lecture room, the other a combined physics-chemistry laboratory; an enlarged kitchen and cafeteria in a new location, mechanical drawing facilities, a paved parking lot, tennis courts, and an outdoor swimming pool.

On January 30, 1965, DeMatha's basketball team, under now Basketball Hall of Fame coach Morgan Wooten, defeated Power Memorial High School with Lou Alcindor (Kareem Abdul-Jabbar) of New York, breaking their 71-game win streak. The game established DeMatha's national reputation as an athletic powerhouse.

The enrollment as of September 1969 had grown from the original 18 students of 1946 to 515 students, of which 135 were freshmen. The senior class numbered 113 and the staff, including a full-time librarian and two secretaries, numbered 28. In addition, maintenance was handled by a staff of three, and the cafeteria staff totaled five.

The school's enrollment climbed to over 800 students, straining the physical facilities. Improvements continued. The gym was totally refurbished in 1977; the cafeteria saw major renovation the same year. The basement of the monastery had been pressed into service as a typing room. Fort Necessity, now called The Annex and currently the Anthony Fotos Arts Center, had been totally remodeled and used as a band room and classroom, before it was damaged by a fire.

After the fire of July 1979, the school was able to erect three temporary buildings adjacent to the burned-out Annex. These buildings were re-furnished and served as the facilities for the music program, theology and business program. After an extensive fund-raising campaign during the 1979-1980 academic year, the Phase I and Phase 2 appeal of the DeMatha Fund began financing the plans for a new addition to the high school and for some renovation of the existing building. For ten years the school continued its review of the needs of the building and the school community with the capable assistance of architect, Mr. Michael Mulhern, Class of 1972, of the Mulhern Group, in Denver, Colorado.

After accepting the construction bid from builder Edward M. Crough, Inc. of Rockville, Maryland, the groundbreaking ceremony for the new building took place on October 12, 1988. The addition comprised three floors including a new chapel, counseling center, library, administrative offices, seven classrooms, a lavatory, music rooms, faculty lounge, meeting rooms, business office, and development office. In addition, the gym area, athletic offices, locker rooms and cafeteria were remodeled.

After many years of fund raising, prudent fiscal responsibility and extensive architectural planning, the new wing opened in September 1990, with the formal dedication on September 19, 1990. The celebrant of the dedication ceremonies was James Cardinal Hickey, Archbishop of Washington. Present for the ceremonies were Trinitarian Provincial Fr. Anthony D'Errico, O.S.S.T. and other members of the Board of Trustees, Trinitarians, faculty and students, architect Michael Mulhern, builder Edward M. Crough, members of the Board of Advisors, representatives of various school organizations, and other leaders of the Church and civic communities.

The school administration soon recognized the need for the construction of an additional facility such as a multi-purpose building. The Brendan McCarthy '64 Activities Center, also designed by Mr. Mulhern, was completed during the 1996-97 school year. The upper level of the two-story activities building consisted of a large multi-purpose room for assemblies, meetings, concerts, athletics activities and drama productions. The lower level housed a training room and office, weight room, three classrooms including a photography lab and dark room.

In June of 2000, Mr. John L. Moylan, the first lay principal of a Washington Catholic school, stepped down after serving 45 dedicated years at DeMatha, 33 as its principal. Dr. Daniel J. McMahon, Class of 1976 and a veteran faculty member, was named his successor.

In November 2001, the school purchased the Banning Property, 2.2 acres on Route 1 adjacent to the original campus. Working with the Trinitarian leadership, the school undertook a 2004 capital campaign, 'A Crusade for Tomorrow', to fund renovation and construction.

As a result of this campaign, the school now features a 72,000 square foot convocation center, dedicated by Archbishop Donald W. Wuerl on March 5, 2010. The Center houses additional classrooms, the Coughlin Strength & Fitness Center, the Kilby Alumni Lounge, a wrestling room, athletic offices, a batting cage, training room, locker facilities, athletic storage and a 1600-seat gym. In addition, the renovation included a new gateway for the school's Route One entrance, three new parking areas, and a plaza behind St. John de Matha Hall, the former Monastery.

In 2009, the Brendan McCarthy '64 Center became the home of the DeMatha Music Program, with extensive acoustical renovation of the building that houses bands, strings, percussion and choruses. The Hanley Science Wing, with state-of-the-art science facilities, opened in 2011, with the dedication on October 3rd of that year.

On August 23, 2014, the new convocation center was dedicated as the LT (SEAL) Brendan Looney '99 Convocation Center, in memory of a distinguished alumnus who lost his life serving his county in Afghanistan.

DeMatha has earned an enviable reputation for its academic, athletic and music programs, as well as for its services to the local community. Our students identify very strongly with the school and are proud to be known as members of the DeMatha Family. The student body comes from several Maryland counties, including Prince George's, Montgomery, Anne Arundel, Charles, Calvert and Howard, the District of Columbia, Northern Virginia and several foreign countries.

It has always been part of DeMatha's history to be certain that we are using the best practices which are part of successful schools in the United States. For several years the school administration, faculty, alumni and friends of DeMatha explored governance models of notable Catholic high schools throughout the country. During three different DeMatha Strategic Plan gatherings, the idea of having a different model of governance was discussed with all of the participants. In the Strategic Plan of 2012- 2013, it was clearly stated that a priority would be to explore the possibility of implementing a President, Board and Principal model of governance and administration for the high school.

During this same time period, the Trinitarians in its gathering of all priests and brothers in the USA Province unanimously approved a process to study various models of governance and to make tentative plans to create the new model with the deadline for a decision to be October 2015. During those three years the Trinitarians, along with representatives from the school and advice from both Canon and Civil lawyers, considered a new model of governance. Several times during this discernment process, the ideas were brought to the Trinitarian Board of Trustees and further refinements were introduced. Finally, on June 16, 2015, the new governance model with its by-laws was approved by the Trinitarian Board of Trustees.

In this new model, there would now be the Trinitarians included in both Board Members A and Board Members B; there would be a Board of Directors consisting of qualified lay men and women and non-Trinitarian clergy to assist in the business aspect of the school life; and there would be a President who would be the Chief executive of the high school and charged with furthering the school mission.

On July 22, 2015, the Trinitarian Board of Trustees elected Fr. James R. Day, O.S.S.T. as the first President of DeMatha Catholic High School. Dr. Daniel J. McMahon, '76 continues as Principal. After his election as President, Fr. James worked to nominate others who would become the Board of Directors for the school. There were thirteen individuals who were nominated and approved by the Trinitarian Board of Trustees on May 18, 2016. They are Timothy P. O'Brien '77 as Vice-President and Chair of the Board of Directors; Richard T. Harrington '84 as Treasurer; David M. DiLuigi '88 as Secretary. Joining them are Karen Cook, Penelope Thornton Talley, Deacon Curtis Turner '86, Brian M. Sheahan '80, Timothy S. Hill '95, Scott D. Marchakitus '88, Fr. Shaun Foggo '95, Terry Eberhardt '94, David Aldridge '83 and Susan Marble Barranca. All of these positions took effect on July 1, 2016. This was an exciting moment in the history of DeMatha. It was also significant that this new model of governance was implemented during the school's commemoration of its 70th birthday from 1946 until 2016.

Membership within the Board of Directors renews itself as Directors complete their terms and rotate off while some Directors remain for a second term. The minimum number of Board of Directors is 12 and the maximum number is 24. In 2017, the Trinitarian Board of Members approved nominees to join the Board of Directors and they are DeMatha graduate parent, Dr. Lisa Slade, Business leader Thomas Hoff, Attorney Charles Kenny '68, the parent of DeMatha graduates and Architect, Michael Johnson '80 and DeMatha graduate parent Frank Persico. In 2018, the Trinitarian Board of Members renewed the terms for the three officers within the Board of Directors and approved two new nominees to fill vacancies, and they are Brendan Wooten '88 and DeMatha alumnus parent, Grovetta Gardineer. We were blessed to add Jeffrey Hathaway '77 and Ken Mellett to the Board in 2018 and Tom Kane '86 in 2019. In 2020 new Directors include Arie Kouandjio '10, Jonathan Mason '08, Beverly Grant and Dan Sheehan '89. In 2021 new Directors are Br. William Ciganek, C.F.X., Bernard Durham '80, Timothy Hill '95, Robert Kavetsky '71, Stephanye Maxwell, Esq, CPM, John Mitchell, Patricia Ellis Mitchell, and Anthony Solazzo '97. Every month sees the Board assisting in the development and growth of the long-range plans of the school.

In June 2018, the school embarked on its fourth Strategic Plan, which is now under the leadership of the Board of Directors working with the faculty and local administration. This five-year plan was announced in the fall of 2018 and implemented January 2019.

DeMatha Catholic High School rests on the shoulders of many giants in the field of quality Catholic education. Throughout the many years of instruction on Madison Street, we owe a debt of gratitude to the founding Trinitarians who embarked on a new mission which was fraught with questions, fears and hopes, but almost immediately, the priests and brothers looked beyond the monastery to hire qualified lay person who shared the vision of the Trinitarians for the school.

It is from these insightful leaders in the field of Catholic education that we are able to make progress and continue to educate young men in the Trinitarian tradition. Two of these noble lay persons who joined the Trinitarians early on in the school's history went home to their eternal reward during the 2020 and 2021 calendar year. Legendary educator and coach Morgan Wootten died on January 21, 2020, and his legacy was honored with a celebration of his life on the campus of the school where many, many former coaches, players, students, colleagues, family members and friends came to pray for him and to honor him.

The longest serving principal of DeMatha, John L. Moylan, died on January 15, 2021. Mr. Moylan was the first lay person to assume the principal responsibility in any Catholic High School in the Archdiocese of Washington. He was a significant presence in the history of the school as a French teacher, the founder of the Counseling Center, coach, advocate for DeMatha and its students and administrator his 33 years as principal. His wisdom and his creativity were evident in expanding the curriculum to include music, business and technology courses. A celebration of his life, attended by family, friends, faculty, staff and alumni from around the country, was held on October 24th with a viewing and Memorial Mass in the LT (SEAL) Brendan Looney '99 Convocation Center.

In the midst of these two personal losses to the DeMatha community, the emergence of the COVID 19 pandemic caused significant changes in education within the state of Maryland and throughout the nation. Governor Larry Hogan closed on March 13, 2020, but our teachers made the transition smoothly to on-line learning with the students for the remainder of that year. All of the significant rituals of the ending of a school year-- the prom, Baccalaureate Liturgy and graduation-- were either cancelled due to health precautions or were presented virtually.

This tailoring of the style of learning continued into the academic year 2020-2021. At the end of the first quarter of 2020, we begin to welcome students and faculty back to campus in a hybrid version where students would alternate between in-person learning and distance learning. With the availability of the new vaccine becoming more prevalent in the early weeks of 2021, more students and faculty are returning to on-campus learning, and the 2021-22 school year began with in-person learning under Covid prevention protocols.

The year 2021 is the beginning of DeMatha's 75th Anniversary as a Catholic School. The actual first day of school was September 9, 1946, and many plans are underway to commemorate this Diamond Anniversary with celebrations and liturgies. DeMatha launched the *DeMatha Forever* Campaign in the early fall of 2021 which includes fund raising for increased need-based financial aid and scholarships, establishment of a quasi-endowment and the construction of a new Engineering, Arts and Robotics Building to replace the Anthony Fotos Art Center, formerly named the "Annex" and originally named "Fort Necessity" back in 1947. This garage-turned academic center has served students well as it housed classes in art, mechanical drawing, journalism, English, engineering and more through the end of the 2022 school year. On October 8, 2021, we had the ground breaking ceremony for The Cross Center of Engineering, Arts and Robotics, as the new facility will be known, which will match the quality of the teaching and teachers who are part of our daily curriculum.

As the school enters its 8th decade, DeMatha will continue to provide the best possible environment for the education of the next generations of young men. The future continues to look bright as the school remains committed to producing Faith-Filled Gentlemen and Scholars, extending a tradition that began in 1946 with just 18 students.

THE TRINITARIANS

The Order of the Most Holy Trinity and of the Captives (Trinitarians) has its origin in the 12th century when a young Frenchman, John de Matha, was teaching at the University of Paris. John left his teaching position, began his studies for the priesthood and was ordained shortly thereafter. It was during his first Mass that John was moved to found a religious community of priest and brothers whose primary purpose was the releasing of Christian slaves who were imprisoned for their faith by various groups of invading Moors.

The Trinitarians were unique from their very beginning: they were the first group of religious men who would live together in community, take vows poverty, chastity and obedience, yet still work with the people in bringing freedom and liberty to captives. Religious experience was important in the life of John and helped shape some of the traditions in the community. Two of these are worth noting: the red and blue cross reminded John of the freedom which the Holy Trinity gives to us and which he wanted to share with all in need; also, during his many periods of prayer and meditation in the forest of Cerfoid, France, the stag became a familiar presence to the early community. These symbols have remained as indicators of the community throughout centuries.

For over 800 years the Trinitarians have continued their work of bringing freedom to persons in need. Freedom and oppression are words that can indicate many diverse situations. It has been the Trinitarians' unique charism to extend themselves to any area in the lives of people that need to be improved. The small community of Trinitarians in France began to spread throughout the world. Groups of religious settled in Spain and Italy. The history of the community has many facets worth noting: the great 15th century Renaissance humanist, Robert Gaguin was the Minister General of the Trinitarians; Trinitarians accompanied the historic voyages of Vasco de Gama (1498), De Soto (1539) and Cortez. Finally, the Trinitarians were invited by Thomas Jefferson to intercede in the release of 119 American Seamen captured by the Barbary pirates. The French Revolution, however, prevented the American Government from completing this request.

The Trinitarians came to the United States in the early 1900's and began working in New Jersey and Pennsylvania with parish churches devoted to the care of immigrants to America. It was in 1931 that the American Trinitarians purchased the property that became St. John de Matha Monastery and DeMatha Catholic High School.

In addition, the early religious in the United States began working in Texas, Illinois, California, and Maryland. At the present time, the Trinitarians are engaged in various ministries in the Church: parish ministry, high school teaching, chaplaincies for prisons and hospitals, college and seminary administration, and an advocacy program on behalf of persecuted Christians. Within the United States, Trinitarians are ministering in Maryland, New Jersey, Florida, Texas and Nevada. Internationally, the Order is found in 24 countries throughout the world: Canada, USA, Mexico, Colombia, Brazil, Bolivia, Peru, Chile, Argentina, Cameroon, Congo, Gabon, Madagascar, Morocco, Austria, France, Italy, Poland, Spain, Saudi Arabia (Middle East), India, South Korea, Vietnam and the Philippines.

FINANCES

DeMatha depends primarily on tuition and fees to meet its financial obligations. Our budget is very carefully constructed and reflects the needs of the school for the current year. The full and prompt payment of tuition and fees is essential in order for the school to function.

DeMatha tuition does not really reflect increased operating expenses. The generous aid of parents' clubs, booster clubs, student fund-raising activities and the contributed services of the Trinitarians and lay faculty offset some expenses.

In light of the above, IT IS IMPERATIVE THAT ALL TUITION AND FEES ARE PAID PROMPTLY WHEN DUE. Your cooperation is appreciated.

Listed below is information for the 2023 - 2024 school year.

I. TUITION AND FEES

Enrollment Fee (paid in February prior to year of attendance):

\$850 new students, **\$300** returning students.

Tuition **\$ 21,950.**

Parents' Organization Fee **\$ 40.**

Graduation Fee - (seniors only) **\$325.**

FAILURE TO PAY TUITION AND FEES WHEN DUE MAY RESULT IN the student's suspension or expulsion.

If tuition and fees are not paid when due, the student may be suspended from school for up to ten (10) class days. During this time, the student will be prohibited from participation in all academic and extracurricular activities (including sports teams) and any student services will be suspended. After ten (10) class days of absence due to non-payment have accumulated, a student will be dismissed from school.

Note, a student will not be allowed to take final exams unless all tuition and fees are paid in full by May 1, 2024.

No transcripts, grades, or records will be released to another school (including a transfer school), university, or employer until all financial obligations to DeMatha have been satisfied. Students will not be permitted to enroll for an academic year until all financial obligations for previous academic years have been satisfied.

A \$35 fee will be charged in the case of any deposited check that is returned by a bank. DeMatha's bank automatically re-deposits returned checks up to two times.

II. RE-ENROLLMENT FOR 2023-2024

A student returning to DeMatha must register through the Veracross portal by **February 15, 2023**. A non-refundable Registration Fee of **\$300** must be paid at that time. After **February 15**, the Registration Fee increases to **\$400**.

III. PAYMENT PLANS

Choice of three payment plans:

A. Full payment of tuition and fees by **July 1, 2023**. Payment made directly to the school.

OR

B. Ten equal monthly payments. Payments begin in **July 2023** and continue through **April 2024**. Automatic withdrawals are made from a savings or checking account on the 5th or the 20th of each month. The plan charges a **\$30** fee (automatic withdrawal) to initiate the account.

OR

C. Four equal quarterly payments.

IV. REFUND POLICY

Unless a student is withdrawn by written notice, received by the **Registrar** prior to **July 15, 2023** DeMatha may require payment of the tuition and charges for the entire academic year. Withdrawal, dismissal, absences or illness of the student during the year does not release any portion of this obligation.

V. YEARBOOK POLICY:

Each student will receive one complimentary yearbook at the start of a new school year following the year of attendance at DeMatha.

SCHOLARSHIPS AND FINANCIAL AID

Academic Awards: DeMatha offers a limited amount of Fr. Cyprian Nusca Academic partial scholarships divided over 4 years. These scholarships are based on academic excellence as determined by previous school records and standardized test scores. To be eligible for these awards a student must list DeMatha as one of his two eligible choices when applying for admission to a Catholic high school.

Archdiocesan Grants: The Archdiocese of Washington provides grants to students based on family need. Applications are obtained from the school and filed prior to the school year for which aid is sought.

Archdiocesan Tuition Benefit Plan: Tuition reductions of \$500 may be available to students whose parents work full-time in an Archdiocesan elementary school or a participating Catholic high school in the Archdiocese. Applications for this benefit should be obtained from the employer school and filed with DeMatha Catholic High School.

Band Awards: A limited number of band scholarships are available to students who show exceptional talent and ability and who have financial need. Interested students should contact the Director of Bands to arrange for an audition.

Brothers: Additional members of the same family attending DeMatha receive a \$1,000 reduction in tuition.

DeMatha Grants: DeMatha Grants based strictly on need are applied for in the year prior to the school year for which aid is sought. Contact the school for application information.

Art Awards: Three \$500 Art Scholarships will be awarded to incoming 9th graders. Interested students must complete an application by January 15 of the year prior to beginning at DeMatha.

OFFICE HOURS:

All Offices: Monday through Friday, 7:45 a.m. to 3:30 p.m.

Appointments for meeting with Administration (President or Principal) are to be made through the Main Office by calling 240-764-2200.

****All visitors to the school must report to the Administration Center upon arrival to sign in and receive a visitor's badge.**

Teaching Faculty: Parents wishing to speak to teachers may call during the above hours to leave their names and telephone numbers. Faculty telephone numbers will not be given out to parents or students. Interviews with faculty members may be arranged up to 3:30 p.m. Monday through Friday. Under no conditions are parents or students to call faculty at their homes. All communications are to be arranged through the school office. Teachers will return calls within 48 hours. You may also e-mail faculty via the DeMatha website at www.dematha.org (click on Faculty and Staff Directory).

Telephone numbers:

School	(240) 764-2200
Business Office	(240) 764-2215
Athletic Office	(240) 764-2251
Development Office	(240) 764-2222

Fax Numbers:

Main Office	(240) 764-2275
Counseling Center	(240) 764-2276
Admissions Office	(240) 764-2277

SCHOOL HOURS:

7:00 a.m. School opens for early arrivals. Students must go to the cafeteria.

7:30 a.m. Students may go to lockers and classrooms.

7:45 a.m. School offices open

8:15 a.m. Classes begin

2:55 p.m. Close of the school day

3:30 p.m. * School building and school grounds officially closed.

*Students participating in school activities of any kind may only be in those areas designated for the specific activity. A proctored transportation waiting room is available until 5:00 p.m. All students waiting for rides **must** go to this room after 3:00 p.m. Students may not leave school grounds after 3:00 p.m. and then return for transportation.

WEEKLY BULLETIN:

"Antler Points", the week in preview, will come out on Sundays via email and contain highlights to things you might need to know. Activity schedules, announcements, events, and other information. This weekly bulletin is also available on the school's website at www.dematha.org

REMIND:

Clubs, sports teams and organizations are to communicate using "Remind" as to target the specific people impacted by such announcements.

PARENT ALERT:

Get the latest communications from DeMatha via e-mail with up to the minute emergency notifications or school cancellations. Check the website under Parents for details and instructions on registration.

DM STAG STORE:

DeMatha apparel and merchandise can be purchased at the Stag Store located in the Convocation Center. Online ordering can be accessed from the DeMatha website @ store.dematha.org. If you have any questions about hours or product availability, please call 240-764-2217.

CHANGE OF ADDRESS:

Change of home address and/or telephone number can be made online through Veracross Parent Portal or reported to the school's main office as soon as possible. (Only one home address per student.)

STUDENT ID AND ID CARDS:

The Veracross Person ID is unique for each student. This number is considered the Student ID and can be found on ID cards, schedules, and report cards. Student ID Cards are provided to students as part of the beginning of school orientation each year. Replacement cards can be requested for a fee of \$10 in the Technology Center. Your Student ID Card is used for identification, door access, attendance check-in, printing, and participation in the optional online payment program for the cafeteria. Students are expected to bring their Student ID to school each day and must present their ID upon request by any faculty or staff member. **At no time should a student loan his ID card or his ID number to another student.**

FUNDRAISING DRIVES:

Students and parents are asked upon occasion to volunteer their services in fundraising programs. Fundraising by clubs or classes, such as tag days, must receive approval of the Dean' Office.

EMERGENCY HEALTH CARE:

In the event of accident or illness on school grounds, students should report to the Attendance Office to be evaluated and then referred to a health care professional if necessary. Health regulations prevent the school from dispensing any medication such as aspirin, cough medicine, etc.; however, immediate first aid and emergency treatment are available in the training room or in the Attendance Office until either the parents or hospital are called. In the event of illness, parents are called to advise them regarding the illness and to make arrangements for the student to be released from school. In the event of accident and/or if hospitalization might be required, parents are called so that authorization may be received. In the event that parents cannot be located, students are taken to Doctors Community Hospital, which is the closest to the school. Parents are required to complete emergency cards listing the names of the family physician and hospital desired in case of emergency. Parents should be sure to notify the school of any serious chronic health problems such as sight problems, hearing problems, diabetes, epilepsy, etc., so that appropriate attention may be given to the student.

REPORTING OF CHILD ABUSE AND/OR NEGLECT:

Employed personnel of DeMatha Catholic High School are required by law to report suspected cases of child abuse and/or neglect. For further information, see Appendix D.

SEARCH OF STUDENT LOCKERS, BOOKBAGS, CLOTHING AND AUTOMOBILES:

In January, 1985, the U.S. Supreme Court ruled that school officials have the right to search students under their jurisdiction when there are "reasonable grounds for suspecting that the search will reveal evidence that the student has violated or is violating either the law or the rules of the school" and the search is conducted in a reasonable manner.

When the school administration has appropriate cause for a search under the above statement, it will conduct the search of a student's car, clothing, locker, and/or book bag. This search will be conducted by a school administrator and, to the degree possible, not in view of any other students in the school. Search of a student's person would be conducted in an administrator's office with no less than two staff members present.

USE OF PUBLIC LAW ENFORCEMENT OFFICIALS BY THE SCHOOL:

A cooperative effort is maintained between DeMatha High School and the local law enforcement agencies (Hyattsville Police Department, Prince George's Police Department, etc.). Law enforcement officials may be summoned to conduct investigations of alleged criminal conduct on the school premises or during a school sponsored activity if it is felt by the school administration that criminal conduct or alleged criminal conduct is taking place. Law enforcement officials may also be summoned to maintain or restore order when the presence of such officers is necessary to prevent injuries to persons or property.

ATHLETIC INJURIES:

DeMatha provides a certified athletic trainer and adult supervision capable of rendering basic first aid to students participating in interscholastic athletics at all practices and home games. This aid is limited to basic care and diagnosis and if, in the judgment of the coaches, further medical assistance is needed, authorized emergency personnel from local ambulances, rescue squads, fire departments or hospitals are called.

STUDENT HEALTH RECORDS:

Our Athletic Trainers act as school nurses during the regular school day and are required to maintain all health and immunization information for all students.

- Athletic Trainer System (ATS) registration. This registration is REQUIRED FOR ALL DeMatha students regardless of whether they are athletes or not.
- Updated health form packets must be completed in order to attend classes. Documentation copied from a previous school can be used if within the correct time frame.

PARTICIPATION ON INTERSCHOLASTIC TEAMS:

Students who are candidates for interscholastic teams must have an athletic health form completed by a physician and permission must be given by the parent and/or guardian in order for a student to participate. In addition, parents must complete an insurance form indicating which medical plan they have for their son in the event of an athletic injury. DeMatha does not provide medical insurance for athletic injuries. Upon admission to DeMatha, the original health form includes a section relating to athletic participation. For each subsequent year of attendance at DeMatha, a student must have another physical prior to trying out for any athletic teams.

The athletic physical may be obtained from private physicians or may be taken at DeMatha when athletic physicals are scheduled. This normally takes place in early summer and notices are sent to all families.

CONCUSSION TESTING

DeMatha utilizes a comprehensive turn-key sports concussion management system for our contact-collision student-athletes called XLNTbrain Sport.

- Pre-season baseline Neuro-Cognitive Testing. Athletes take XLNTbrain-cog neuro cognitive test to establish their baseline before playing at the start of the season.
- Instructional videos for athletes/coaches/parents. A series of educational videos inform awareness and the latest findings in concussion treatment.
- Community medical professional training and certification. A series of videos and training material to inform and update local medical professionals on sports related concussions.
- XLNTbrain-mobile includes the XLNTbrain Sideline Assessment Tool and the XLNTbrain Balance Test for detecting and reporting concussion using a smart-phone from anywhere.
- XLNTbrain-cog Post concussion neuro-cognitive evaluations to monitor severity and recovery of concussions.
- XLNTbrain-tracker monitors the concussed athlete's recovery step by step giving quick visualization or detailed information on the athlete's progress.
- Gradual return to exertion program. A program of supervised exercise that get the recovering athlete back to training gradually until it's safe to play again.
- Compliant with new State laws.

FIELD TRIPS:

For a student to participate in a field trip or any off-campus school activity, parents must complete the standard permission form. This form will be provided by the Moderator of the activity. (See Appendix C).

LOST AND FOUND:

Articles which are found (books, clothing, wallets, money, gym clothes, bags, shoes, etc.) should be turned into the Attendance Office. Students claiming lost items must be able to identify them. Unclaimed lost and found items will be donated at the end of every quarter.

TRANSPORTATION TO AND FROM SCHOOL FUNCTIONS:

The school offers transportation to many school functions including transporting participants in all athletic team functions. The school bears no liability for students choosing to transport themselves to school functions. (See Appendix C for sample permission form).

RE-ENROLLMENT:

Registration for returning students takes place in January and February. In January, an email will be sent to all families when the re-enrollment portal is open in Veracross. At that time parents should follow the instructions to log in and re-enroll their son. A non-refundable fee will be due at that time. Failure to re-enroll may result in the loss of your son's space at DeMatha.

SNOW DAYS OR OTHER EMERGENCIES:

Cancellation of School Before Opening:

DeMatha follows the policy of Prince George's County Schools, ***if school is cancelled before the school day begins.***

Delayed Openings of School:

DeMatha follows the policy of Prince George's County Schools for cancellations and delayed openings.

Early Dismissal:

Once the school day has begun, DeMatha will make its own decision concerning early dismissal from school due to snow or other emergencies.

SNOW POLICY FOR BUS TRANSPORTATION:

Delayed Openings of School:

If school is delayed 2 hours, the bus routes start TWO hours later. If Prince George's County schools are closed DeMatha will be closed and the bus will not run.

Early Dismissal:

If schools in Prince George's County are closed before the completion of the school day, the bus will follow directions of DeMatha with regard to early dismissal.

SPECIAL ANNOUNCEMENTS CONCERNING THE SCHOOL ARE POSTED ON THE SCHOOL WEBSITE AND SOCIAL MEDIA.

EXTENDED FORCED SCHOOL CLOSINGS:

In the unlikely event of a forced school closing, the school may continue to operate on a distance-learning basis for a period no longer than four weeks. In the event that the school will need to remain closed beyond that time, the school may extend the school year up to and including June 30th. The school may also schedule weekend classes.

MESSAGES FOR STUDENTS:

The Attendance Office will deliver only those messages of an emergency nature to students. Arrangements regarding rides, appointments, etc. should be made before the student arrives to school. Students expecting messages should check with the Attendance Office.

SHUTTLE TO COLLEGE PARK METRO STATION:

DeMatha provides a shuttle service to and from the College Park Metro station on regular school days. A pick-up is made at 7:45 a.m. and the return trip is made approximately 20 minutes after the close of the school day.

EXTRA-CURRICULAR ACTIVITIES:

All students are encouraged to participate in the extra-curricular programs available at DeMatha. The school advises significant participation in a few activities, as opposed to token participation in many. When a student's extra-curricular activities prove detrimental to the successful completion of his regular schoolwork, he is advised to lessen his extra-curricular participation.

Activities currently available are:

Academic Quiz Bowl

Anime Club

Art Club

Asian American Club

Aviation

Brothers Standing United

Chess Club

DeMatha Latino Community

DeMatha Players (Theatre)

Dungeon and Dragons Club

Ecology Club

Film Club

Investment Club

Mock Trial

Music Production Club

National Honor Society

National Society of Black Engineers

Science Scholars (Invitation Only)

Software Engineering Club

Sports Debate Club

Student Government Association (SGA)

The Stagline (school newspaper)

Video Game Club

The list of activities changes, depending on the needs and the interests of the student body. The school is willing to sponsor any worthwhile activity for which there is sufficient interest.

AWARDS PRESENTED AT BACCALAUREATE AND/OR GRADUATION

THE CARDINAL'S AWARD -- Presented to a senior based on a consideration of exemplary Catholic character, personality and citizenship.

DeMATHA CATHOLIC HIGH SCHOOL CITIZENSHIP AWARD -- Presented to a senior based on consideration of exemplary Christian character, personality and citizenship.

DeMATHA CATHOLIC HIGH SCHOOL ALUMNI AWARD FOR EXCELLENCE and DR. CHARLES 'BUCK' OFFUTT FACULTY AWARD FOR EXCELLENCE -- Presented to seniors who have exhibited overall excellence in all academic areas and have been outstanding school citizens through their significant contributions and leadership in school activities.

DeMATHA CATHOLIC HIGH SCHOOL SCHOLAR-ATHLETE AWARD -- Presented to a senior for outstanding academic and athletic achievement.

DeMATHA PARENTS' ORGANIZATION AWARD -- Presented to a senior who has displayed unusually fine motivation, work habits, and character. This award is in honor of the fathers and mothers of DeMatha High School students. Awarded at Baccalaureate Mass.

DEPARTMENT ACADEMIC AWARDS -- Presented to those seniors who have been chosen by the department chairs as being the outstanding students in their subject areas.

H. THOMAS EASTMAN AWARD -- Presented to a senior who best exemplifies those characteristics which made Mr. Eastman a true gentleman and a valuable member of the DeMatha faculty: Devotion, Kindness, Concern, Humility and Loyalty. Awarded at Baccalaureate Mass.

FATHER AUGUSTINE DERRICKS, O.S.S.T. -- Presented to a senior who has demonstrated to DeMatha and the larger community outstanding service in the tradition of the first American Trinitarian, Father Augustine Derricks, O.S.S.T. Father Derricks, a convert and African American, demonstrated a life-long commitment to social justice that also marked his career as a priest.

FATHER PATRICK T. GLYNN, O.S.S.T. AWARD -- Presented to a senior who, through his outstanding character, classroom achievement and participation and achievement in athletics, best exemplifies those traits to honor the memory of Father Patrick.

JOHN H. MITCHELL BAND AWARD -- Presented to a senior who has contributed most significantly to the success of the band program at DeMatha High School. Awarded at Baccalaureate Mass.

JOHN L. MOYLAN AWARD FOR ACADEMIC EXCELLENCE -- Presented to a senior who, through his outstanding scholarship in a wide range of courses, exemplifies the commitment and ideals of John L. Moylan, Principal from 1969-2000.

MARY FAVRET KERLEY - KATHERINE MAUSER AWARD -- Presented to a senior who has displayed exemplary loyalty and devotion to DeMatha High School. Awarded at Baccalaureate Mass.

KIWANIS CLUB AWARD -- Presented to a senior student who has displayed outstanding school citizenship. Awarded at Baccalaureate Mass.

NATIONAL HONOR SOCIETY -- Recognition given to those students, on the basis of maintaining a B (3.0) average or above, who have given evidence of leadership, service and good character. Awarded at Baccalaureate Mass.

SERVICE AWARDS -- Presented to the senior members of school organizations who have contributed most significantly to the success of these organizations. Awarded at Baccalaureate Mass.

U.S. MARINE CORPS DISTINGUISHED AWARDS -- Presented to seniors who have excelled in scholastics, varsity athletics or music and have exhibited outstanding leadership and character traits. Awarded at Baccalaureate Mass.

THE NATIONAL HONOR SOCIETY, VALOIS CHAPTER:

The National Honor Society is sponsored by the National Association of Secondary School Principals. It was founded to single out the individuals in a school who are truly outstanding in their academic and service performance and who exhibit superior character and leadership to others.

Membership is open to 10th, 11th, and 12th grade students who have been in attendance at DeMatha the equivalent of at least one full semester. To be selected, the NASSP states that a student must exhibit outstanding SCHOLARSHIP, LEADERSHIP, CHARACTER, and SERVICE.

Scholarship: The student must have a minimum cumulative scholastic average of 3.50 for the entire time he has been at DeMatha.

Leadership: Students must show that they have leadership qualities and/or have held leadership positions in the school, their church or their community.

Character: There must be no evidence that the candidate is of poor character. Generally, this is measured by his conduct in school; however, character ratings by faculty members who know the student must indicate above average character traits.

Service: The candidate must show that he has been of service to his school, church or community. He must also be willing to accept the responsibilities of service to the DeMatha community required of all National Honor Society members.

SELECTION PROCESS:

In October, those wishing to be considered for membership in the National Honor Society should obtain an information sheet from the Counseling Center. The student will supply in this information sheet a description of how he has already demonstrated leadership, character, and service. It is also necessary for the student to maintain his academic standing by earning the minimum average for the first quarter of the year in which he is being considered for membership.

The Faculty Council, five teachers chosen by the Principal, then considers all of the students who are candidates for membership. In addition to reviewing the information supplied by the candidates, they also examine the current report card, overall academic record for their years at DeMatha, the disciplinary record, and the comments elicited from the faculty at large. The faculty Council then recommends to the Principal the candidates who not only meet the four criteria announced by the NASSP, but who also demonstrate excellence in these areas.

Membership in the National Honor Society requires that the student maintain not only his minimum scholastic average (see Scholarship, pg. 37), or better, but also maintain the high standards of service, leadership and good character. Should a National Honor Society member fall short in any of these areas, the usual probation is one marking period. The academic standing of NHS members will be reviewed using the end of the first quarter grades, using the end of the first semester grades, using the end of the third quarter grades, and using the final average. If the GPA for any of these has fallen below 3.50, the student will be given one marking quarter to raise his GPA to 3.50. If he does not do so, he will forfeit his membership in the NHS.

SERVICE PROJECTS:

The National Honor Society maintains a free tutoring program for students of DeMatha; performs service to the neighboring communities in the form of volunteer work on clean up days; coordinates the annual Blood Drive; and generally makes itself available to help whenever needed.

TRANSFER STUDENTS:

Transfer students with acceptance into the NHS from their previous school will be admitted into our DeMatha Valois Chapter NHS. These students will need to present certification to the chapter advisors and will be subject to DeMatha's NHS guidelines.

CAMPUS MINISTRY OFFICE (CMO):

The Campus Ministry Office, in conjunction with the Theology Department, provides opportunities for the spiritual development of the students, faculty, and staff. Under the direction of the Campus Ministers, the school strives to maintain a genuine Catholic/Christian atmosphere and instill Christian values in the students. These goals are achieved through the following program:

- 1) **Worship:** Catholic Mass is offered every day during school for individuals or classes who wish to attend. School-wide Masses are offered several times a year, and these celebrations are mandatory for all students and staff. In addition, prayer services are held during Advent and Lent. The Sacrament of Reconciliation is offered throughout the year by appointment. In preparation for the Church's major feasts confession is scheduled for all students and staff.
- 2) **Class Retreats:** Every year, each class (9-12 grade) is offered the opportunity to increase their spiritual and social awareness through our retreat program. The retreat program offers DeMatha students tools to grow in their relationship with God. The CMO invites faith-filled guest speakers to address the students during their respective class retreats as a way to model an active faith life.
Each class-level retreat is a mandatory graduation requirement for every student.
- 3) **Social Action:** Students are given numerous opportunities to show Christian witness through social action to the poor and needy. This is done with the cooperation of relief agencies and charitable organizations in the area. Specifically, food and toy drives are planned during the Thanksgiving and Christmas seasons. *(for more information, please see the Christian Service Section of the Student Handbook)*

Christian Service: Since service to others, especially those most in need, is essential to the Christian life and to living the Gospel, all DeMatha Catholic High School students are required to perform Christian Service in order to graduate. The Campus Ministry Office oversees this program by organizing group service activities, assisting in the placement of students in service locations, guiding students in reflection on their service, and compiling the number of hours completed by each student. Completion of service hours and the service reflection paper is a graduation requirement. A quick overview of the Christian service requirements is below:

DeMatha's Christian Service Program Basics:

- The service completed must be voluntary and non-paid. Students are encouraged to approach their service requirements as opportunities to better understand their communities, to become more aware of their God-given gifts, and to learn to love as Jesus did.
- Students will be given credit for service hours that fit the specifications of each year's requirements. This is subject to the discretion of the Director of Christian Service.
- Students are responsible for submitting their service logs for verification via Mobileserve, our service hours tracking app.
- **Christian Service hours are required every year. Any student who does not finish his hours at the end of a school year will not be allowed to continue to the next grade as a DeMatha student until his required hours are completed.**
- Any Christian Service hours should be submitted at the end of the month in which the hours were completed (*e.g. service hours completed on October 15 are due by October 31*); any hours submitted outside this window may not be accepted.

How to complete DeMatha's Christian Service Hours:

1. Find a non-profit site/organization that fits the requirements of a student's academic year.
2. Upon finishing the hours, students should submit their hours to Mobileserve, our service hours tracking app.
 1. They must include the service organization, a description of what they did and the supervisor's name/email.
3. After the hours are submitted, the Director of Christian Service will review hours and either approve them or consult with the student.
4. **If a student doesn't complete the required hours by the end of the school year, additional hours will be added and students will have until the end of summer school to complete all required hours for the previous school year.** If the student doesn't complete the remaining hours by the end of summer school, he will not be allowed to continue to the next grade as a DeMatha student until all hours are finished.

Christian Service Requirements by Grade Level:

Year	Total hours required	Due Date for hours (penalties added for lateness)	Type of service required
Freshman + <i>"Bettering Our Communities"</i>	5	Hours must be submitted at the end of the month in which they are completed. Last day to submit May service hours: May 24, 2024	must work for non-profit organizations, schools, environmental clean up, homeless shelters, food pantries, rec leagues, etc.
Sophomore + <i>"Meeting Basic Needs"</i>	10	See above; Last day to submit May service hours: May 24, 2024	must work with a non-profit organization that serves the needs of those who are hungry or have inadequate housing/homeless
Junior+ <i>"Encountering Christ in the Poor and Marginalized"</i>	20: all must be direct contact	See above; Last day to submit May service hours: May 24, 2024	Must be with a non-profit organization that serves the needs of those who are marginalized or experiencing hardships/burdens. Must choose an organization that serves one of the following groups: Elderly, Special-needs, Veterans, Sick, Hungry, Homeless or those with inadequate housing, Refugee/Immigrant
Senior <i>"Men of Faith and Action"</i>	20: all must be direct contact	Hours due at the end of the month in which they were completed Senior hours due: March 4, 2024	Same as junior requirements; seniors may work with the same organization as junior year.
Senior Reflection Paper**	_____	March 20, 2024	<ul style="list-style-type: none"> • Graduation requirement • Seniors must complete the senior reflection paper once they are finished with their senior service hours. • Seniors who have completed all hours by March 4, 2024 have the option of turning in a written reflection OR doing a personal service interview with a faculty member. Details for both will be given during the year.

+If a student's hour requirement is not completed by 5/24/24 the student will be assigned penalty hours and students will have until the end of summer school to complete and submit their required hours for that grade level. If the summer hours are not submitted by the appointed date, students will be removed from classes for the upcoming school year and will not be allowed to start school until all hours from the previous year are completed and submitted.

****ABSENCE IS NOT AN EXCUSE FOR MISSING THE SENIOR PAPER/INTERVIEW DEADLINE.** Please email paper or turn in a hard copy to the Director of Christian Service by the appointed date.

DR. DANIEL J. MCMAHON LIBRARY

DeMatha Catholic High School's McMahon Library has for its main objective the objectives of the school itself: the spiritual, intellectual and social development of its students.

To achieve these objectives, the library attempts to provide:

1. A quiet study area for all students.
2. A collection of reference and circulating books and other printed materials (presently containing over 14,000 items). The collection is developed and maintained by a professional librarian. Materials are selected based on their suitability for college preparatory curricula. Monographs are generally cataloged using the Dewey Decimal system and are accessible to the students through Destiny catalog system.
3. The library subscribes to several information services providing both on-campus and remote electronic access to magazines, academic journals, information databases, reference services and much more. Please contact library staff for information on how to gain remote access.
4. Over 40 subscriptions to current periodicals include general and specialized magazines and several newspapers. Current periodicals must remain in the library; however, students may borrow back issues for overnight use.
5. The library maintains a collection of videos, DVDs and other media which are available for use in classrooms. This collection currently numbers thousands of items and is available for faculty to borrow.
6. Students may borrow general collection items for a two-week period. Renewals are possible at the end of the two-week period provided there is no prior request placed on the item by a new borrower. Library collection material renewals must be made in person with the borrowed material at hand. A valid DeMatha identification is required to borrow and renew any materials from the library.
7. Back-issue magazines and other overnight materials must be returned before the start of school the following morning. Fines for overdue materials will be charged. Excessive delinquency in returning materials may result in additional disciplinary measures.
8. The library reserves the right to limit the number of items students may borrow at any time. Removal of any books or materials from the library without proper processing via the circulation desk will be considered as a theft violation, and shall carry appropriate disciplinary action.
9. Computers and library laptops are available for students when the library is open. All guidelines for use of electronic devices in the school apply in the library and will be strictly enforced by library staff. Failure to follow regulations will result in suspension of student's usage at the discretion of the school librarian.
10. Gaming, social media and similar applications are not permitted in the library.
Students should contact library staff beforehand to get permission to use such applications for an academic assignment.
11. The library is generally open before, during and after school. Students should review posted schedules at the library.
12. Loud or disruptive conversation or behavior will result in the offender(s) being expelled from the library. Expulsions may include extended periods of time as well as serving detention. Likewise, abuse of library materials or of borrowing privileges may result in prolonged expulsion and/or loss of borrowing privileges.
13. The library staff is responsible for the repair of damaged library materials. The cost of this repair is assigned to those responsible for the damage. In the same manner, materials that are lost or that have not been returned shall be paid for by the borrower. Report cards and transcripts of grades will be withheld until settlement is made.

PARENT AND BOOSTER ORGANIZATIONS

BAND BOOSTERS

Membership is open to all parents/guardians of students who are participating in the music program.

Members will become involved in various aspects of promoting a solid music program: fostering sound fund-raising activities to assist the projects within the music program; promoting good public relations for the music program; assisting in various duties to further the music program and working within the guidelines of DeMatha Catholic High School.

Meetings: Meetings will be announced by the President of the organization at the beginning of the school year in conjunction with the band directors.

FOOTBALL BOOSTERS

Membership is open to all persons 18 years of age or over who are not presently enrolled in high school and who are interested in the football program and DeMatha and its improvement.

Members will become involved in various aspects of the football program: fostering sound financial management and fund-raising of the DeMatha Family and the football program; assisting in various duties needed to further the football program; sponsoring various social activities to benefit the program and working within the guidelines of DeMatha Catholic High School.

Meetings: Regular meetings will be announced by the Executive Board at the September meeting. Meetings will begin at 7:30 p.m.

LACROSSE BOOSTERS

Membership is open to all parents/guardians of students who are participating in the DeMatha lacrosse program. Membership is also open to all persons 18 years of age or over who are not presently enrolled in high school and who are interested in the lacrosse program at DeMatha and its improvement.

Members will become involved in various aspects of the lacrosse program: fund raising efforts, field preparation, staffing refreshment van, preparing press releases and newsletters, accounting for uniforms and equipment, arranging team transportation and general support of our teams within the guidelines of DeMatha Catholic High School.

Meetings: Regular meetings will be announced by the President at the beginning of the school year.

DeMATHA PARENT ORGANIZATION (DPO)

Membership is required of all parents or guardians of DeMatha students. Dues are \$40 per family. Members help to provide many needed services to the school, including hosting at school functions, and raising funds for projects which assist the school in both general and specific ways. The Parents' Organization sponsors several events during the year including a Freshmen Mother's Welcome Brunch, tuition raffle, Pie Day and the Men of DeMatha cookout. The organization schedules a bake sale for each grade level per school year. Meetings are indicated on the school calendar.

SENIOR BOOSTER CLUB

Membership is open to all parents and guardians of former DeMatha students.

Senior Booster Club provides major financial support for the school through sponsorship of Crab Feasts and other activities. Members are responsible for providing many significant improvements to the school, which would otherwise have been at least difficult or at most impossible to obtain.

Meetings: These are announced by the officers of the Club.

SOCCER BOOSTERS

Membership is open to all parents/guardians of students who are participating in the DeMatha soccer program.

Members become involved in various aspects of the soccer program to provide support of the players: fund raising, social activities, publicity and publications committee. In addition, members also provide video-taping of games and participate in a communication network among players, parents/guardians and coaches.

Meetings: Regular meetings will be announced by the Committee Coordinator at the beginning of the school year.

HOCKEY BOOSTERS

Membership is open to all parents/guardians of students who are participating in DeMatha Hockey. Activities are announced by the Board in September.

BASEBALL BOOSTERS

Membership is open to all parents/guardians of students who are participating in DeMatha Baseball. Meetings and activities are announced by the officers of the organization.

ACADEMIC INFORMATION



ACADEMIC PROGRAM

The program of studies offered at DeMatha prepares the student for further education in colleges, community colleges, technical schools or business schools. Courses are taught on the following levels: Advanced Placement or college level; accelerated college prep.

The required program of studies includes courses in Theology, English, Mathematics, Science, Social Studies, World Languages, Fine Arts, Technology and Physical Education.

Most students graduate with more than the minimum number of credits needed. In choosing a program of studies, emphasis should not be placed on earning a certain number of credits, but rather on the degree of preparation and readiness for the student's career after high school.

Homework Suggestions

Homework: Most students who have academic difficulties have them because they do not realize the importance of consistent homework to success at DeMatha. On the average, a student should be spending two and one-half hours on homework each night.

Each teacher may expect at least one-half hour of a student's time every evening. This half-hour may be divided into:

- a) Review: (5 min.) Daily review of the material in note books since the last test. This daily review eliminates the need to "cram" for a test. It makes one very familiar with the subject matter.
- b) Written work: (20 min.) This time is used to do whatever written work has been assigned for the day.
- c) Preview: (5 min.) Look ahead in the textbook to see what will be covered on the following day. Mark areas to be questioned or areas which need special attention.

Using this system, even when there is no written assignment, there is never a time when a student has no homework.

Testing: Preparation for tests is best done over a long period of time, rather than by "cramming" the information on the previous night. Taking good classroom notes helps in preparing for tests, as does the reviewing of old tests. Students are also encouraged to "predict" the test questions while studying, and then showing them to the teacher to determine how on-target their studying has been.

At the end of each semester students will be taking two-hour examinations -- usually on all the material covered during each semester. It is not possible to prepare for these tests with only two days of work. Students should check the school calendar to determine the semester examination schedule; they should also be in close contact with their teachers to determine as early as possible the agenda for the examination, so that adequate and complete preparation can begin in a timely fashion.

SUGGESTIONS FOR IMPROVING STUDY HABITS

1. Have a good place to study, free from distractions and not too comfortable. Have a desk in a quiet area with all the material needed.
2. Budget your time. Think about how you will use your thirty minutes. Make a schedule; try to get the work done in that time frame. Be thorough, but do not spend unnecessary long periods of time on any one subject.
3. Don't be too comfortable. Never study or read on your bed. Beds are for sleeping, and no matter how well intentioned you are, sooner or later that is what you will be doing. Ensure that the chair and desk area be well lighted and conducive to study and not resting.
4. No radio, TV or phone calls. If you can hear the TV, you will be giving it some of your attention; the same is true of music or voices on the radio. You must direct all of concentration to your studies; later you can direct your attention elsewhere.
5. Divide your time. Two and one-half hours is a long time to study. If you do half of it when you come home from school, and you do the other half after dinner, it is much easier. Make a schedule for the week and keep to it. Schedule in your study time, your relaxing time as well as your other duties.
6. Have a good notebook. Learn to take notes and have a notebook for each class. Ask your teacher to show you the best way to take notes for the class. Studying a well-written notebook can save a lot of time. Write all assignments on a small notebook, so that nothing gets forgotten.
7. Develop a good attitude. Education does not have to be a chore. It can be, and it should be, enjoyable and the means where you discover yourself, your world and your God. Open your mind and allow yourself to wonder and to see how much you can learn from your teacher, from your friends and from yourself. It can be an exciting experience, if you let it.

THE EARNING OF CREDIT UNITS

A full credit is granted for a course taken for an entire academic year (min. 120 clock hours) for which a grade of D or better is obtained. A half credit is granted for a course taken for one semester (min. 60 hours) for which a grade of D or better is obtained. Credits for courses taken prior to grade 9 will not be granted.

DeMatha's policies governing the granting of credit for programs other than those offered during the regular school year are as follows:

Tutoring Credits: Students who have failed to obtain school credit in courses offered during the regular academic year due to illness, absence for a valid reason, or due to the unavailability of a regular summer school program in a particular subject, may receive regular school credit through special tutoring programs. In these cases, the student must receive the approval of the school administration through the counseling center. In order to receive this approval, the tutor must be a certified teacher or must have met the minimum qualifications for certification by the Maryland State Department of Education. The material to be covered will be determined by the school and specifically by the department chairperson of the subject being tutored. Tutoring is allowed only for those courses which were begun in a regular class situation, but were not continued due to reasons mentioned above. The cost of the tutoring must be borne by the parent or guardian of the student.

Summer or Evening School Courses: Students may earn graduation credits at government-approved evening or summer schools with the approval of the school administration. Make-up credits will be accepted from another school provided the course(s) is not offered at DeMatha. Transcripts to include the grade, hours taken and absences must likewise be forwarded before credit is granted to students. Grades obtained are not used in a student's quality point average. A maximum of two original credits may be earned in evening or summer school programs.

Credit by Examination: In exceptional cases the school will grant placement by examination for students who have followed an independent program of study. The examination given will be prepared by the department chairperson in the area to be tested.

The examination will consist of material normally found in the school's program of studies supplemented by material from standardized tests in the subject area, if available. A maximum number of two credits may be obtained in this manner.

Dual Enrollment through Seton Hill University: Through our partnership with Seton Hill University's College in High School program, students can earn college credit for successfully completing qualifying DeMatha courses. College credits earned in the College in High School program can be transferred to most colleges or universities. A full listing of classes currently offered for the Seton Hill College in High School program is available in DeMatha's course catalog.

SELECTION OF TEACHERS

Teachers for all students are selected randomly by our computer system. **PARENTS AND STUDENTS DO NOT HAVE THE OPTION OF PICKING A PARTICULAR TEACHER FOR ANY GIVEN COURSE.** If a student has been scheduled with a teacher he has already had, he **may** be granted a change of teachers, especially if he had a poor academic performance with that teacher in the past.

GRADUATION REQUIREMENTS

In order to graduate from DeMatha, students must accumulate 24 state-approved credits during the four high school years and must earn one credit in Theology for each year of attendance at DeMatha of which the following are required.

Requirements for Graduation:

Theology

4 credits (Students entering after 9th grade earn one credit each year while at DeMatha.)

English

4 credits (These include only English 9, American Literature, World Literature, and British Literature plus Senior Seminar.)

Social Studies

3 credits (These include AP Human Geography or World History, U.S. History, and Government.)

Science

3 credits (Recommend 4 credits)

Mathematics

4 credits

Health and Physical Education

1/2 credit in each

Arts

At least one fine arts class.

World Languages

3 credits

Christian Service

55 hours of Christian service during Freshman, Sophomore, Junior and Senior years (0 credit).

The DeMatha Way

Required for all Freshmen.

Note: Students in grades 9, 10, and 11 must attempt a minimum of seven credits per year while in attendance at DeMatha. Students in grade 12 must attempt a minimum of 6.5 credits per year. Body Composition, independent study courses and repeated electives do NOT count toward this minimum. Likewise, the extra ½ credit awarded for AP Biology, AP Chemistry and AP Calculus BC does not count toward this minimum.

SAMPLE PROGRAM

9th Grade

The Search for God

English 9

Biochemistry

Mathematics

World History (S1) plus one World History Seminar (S2)

World Language

The DeMatha Way/Health

10th Grade

The Living Word

American Literature

Biology

Mathematics

World Language

PE and/or 2 electives

11th Grade

Christian Ethics/Sacraments

World Literature

Chemistry

Mathematics

United States History

World Language

--1 elective

12th Grade

Fundamentals of Catholic Thought and Tradition plus 1 elective

British Literature plus 1 Senior Seminar

Government

Mathematics

--2 and 1/2 electives

These sample programs for each grade level indicates that six credits is the usual load for students. If a student demonstrates that he has the ability, he may choose up to seven credits per year.

PROGRAM OF STUDIES

The DeMatha Way (Freshmen only)

Guided Organization and Learning Support (Freshmen only)

Theology

The Search for God: The Revelation of Jesus in Scripture/Who Is Jesus Christ?

The Living Word: The Mission of Jesus Christ/ Jesus Christ's Mission Continues in the Church

Christian Ethics/Sacraments

Fundamentals of Catholic Thought and Tradition

Catholic Social Teaching

Catholicism in an Ecumenical World

Prophetic Literature

New Testament Scripture

English

English 9

Honors English 9

Survey of American Literature

Honors American Literature

World Literature

Honors World Literature

Advanced Placement English Language and Composition

British Literature

Honors British Literature

Advanced Placement English Literature and Composition

Crime and Detective Fiction

Twentieth-Century Novel

Speculative Fiction

African American Literature

Advanced Film Study

Advanced Creative Writing

The Road to Civil Rights

Sports Journalism

Opinion Writing

Advanced Journalism

Mythology

Film Study

Creative Writing

Speech

Reading and Study Skills

Video Broadcast Journalism

ESOL

Research and Presentation

Social Studies

Foundations of World History

Honors Foundations of World History

European History

Honors European History

The World at War

Honors The World at War

Struggle, Revolution and Empire in the Americas

Honors Imperialism and Independence
Advanced Placement World History
U.S. History
Honors U.S. History
Advanced Placement U.S. History
Government/Law
Honors Government
Advanced Placement Government
Advanced Placement Comparative Government and Politics
The African American Experience
Honors The African American Experience
Advanced Placement Human Geography
Understanding 9/11
The History of Terrorism and Extremism
Honors Foundations of Psychology
Honors History and Systems of Psychology
General Psychology
Economics
Advanced Placement Economics

Mathematics

Algebra 1, Part 1
Algebra 1, Part 2
Algebra 1
Honors Algebra 1
Algebra 2
Honors Algebra 2
Trigonometry
Geometry
Honors Geometry
Pre-Calculus
Honors Pre-Calculus
Advanced Placement Calculus AB
Advanced Placement Calculus BC
Statistics
Advanced Placement Statistics

Computer Science and Engineering

Research and Presentation
HTML
Engineering Design and Problem Solving
Honors Engineering Design and Problem Solving
Robotics
Advanced Robotics
Introduction to Prototyping
Advanced Engineering Design
Advanced Topics in HTML
Computer Programming 1
Computer Programming 2
Advanced Topics in Programming 1
Advanced Topics in Programming 2

Advanced Placement Computer Science
Advanced Placement Computer Science Principles
Mobile APP Design and Development
Seminar in Computer Science

Sciences

Health
Biochemistry
Biology
Honors Biology
Advanced Placement Biology
Chemistry
Honors Chemistry
Advanced Placement Chemistry
Physics
Honors Physics
Advanced Placement Physics
Marine Biology
Seminar and Investigation
Honors Human Anatomy & Physiology
Astronomy
Advanced Placement Environmental Science
Biotechnology
Forensic Science

World Languages

Honors French 1
Honors French 2
Honors French 3
AP French Language and Culture
Honors French 5
Honors French 6
Spanish 1
Spanish 2
Spanish 3
Spanish 4
Honors Spanish 1
Honors Spanish 2
Honors Spanish 3
Honors Spanish 4
Advanced Placement Spanish
Honors Latin 1
Honors Latin 2
Honors Latin 3
Advanced Placement Latin 4
Honors Classical Greek 1
Honors Classical Greek 2
Honors Classical Greek 3
Honors Mandarin Chinese 1
Honors Mandarin Chinese 2
Honors Mandarin Chinese 3
Honors Mandarin Chinese 4
Advanced Placement Chinese Language and Culture

Arts

Fundamentals of Art/Color

Drawing

Painting

Advanced Art

Art History 1

Art History 2

Digital Photography

Digital Photography 2

Basics of 3D Media

Music and Performing Arts

Percussion Ensemble I

Percussion Ensemble II

Advanced Percussion Ensemble

Concert Band I

Concert Band II

Concert Band

Symphonic Band

Wind Ensemble

DM Singers 9

DeMatha Harmonics

Voices of DeMatha

Concert Strings I

Concert Strings

Sinfonia

Advanced Music Theory 1

Advanced Music Theory 2

Advanced Music Theory 3

Advanced Music Theory 4

Advanced Music Theory 5

Advanced Music Theory 6

Extracurricular Music

Jazz Ensemble

Jazz Lab

Pep Band

Business

Accounting

Business Topics 1

Business Topics 2

Economics and AP Economics (Cross-listed in the Social Studies Department.)

Personal Finance

Marketing Concepts 1

Marketing Concepts 2

Physical Education

Physical Education

Introduction to Sports Medicine & Athletic Training

Body Composition

There is a supplementary \$800 fee for taking full-year Independent Study courses. This fee is divided equally among the students enrolled in the course. For one-semester courses the fee is \$400.

GRADING SYSTEM

Grading is on a letter system with approximate numerical equivalents indicated below. Quality points are assigned to each letter grade according to the degree of difficulty of the course. Grades are given on a 4.0 system. The Quality Point Index (QPI) for a particular grading period is an average determined by dividing the number of quality points earned by the number of courses of study attempted. The QPI for the year is based on the final grades only and is computed by taking the total number of Quality Points earned divided by the total number of credits attempted. The cumulative or career QPI is based on the final grades only and is computed by taking the total number of Quality Points earned divided by the total number of credits attempted and is based on grades earned at DeMatha only.

QUALITY POINTS ASSIGNED PER SEMESTER

	Regular Courses	Honors Courses	A.P. Courses
A (94 - 100)	4.0	4.5	5.0
A- (90 - 93)	3.5	4.0	4.5
B (84 - 89)	3.0	3.5	4.0
B- (80 - 83)	2.5	3.0	3.5
C (74 - 79)	2.0	2.5	3.0
C- (70 - 73)	1.5	2.0	2.5
D (65 - 69)	1.0	1.5	2.0
F (Below 65)	0.0	0.0	0.0

Department Chairs, in conjunction with the Principal, establish the grade standards for each course that comes under the department's jurisdiction.

RANK IN CLASS

DeMatha does not rank students.

ACADEMIC RECOGNITION

At the end of each grading period, a list of students who achieve honor grades is posted on the main bulletin board outside the faculty room and on the website.

Principal's List: GPA of 3.8 or above with no grade below B-.

Academic Dean's List: GPA 3.5 or above with no grade below a C.

Honor Roll: GPA of 3.0 or above with no grade below C. Seniors who graduate with honor averages receive special recognition at graduation. Students who achieve a cumulative 3.0 or above for the first seven semesters graduate with honors, those who achieve a 3.5 cumulative average or above for the first seven semesters graduate with high honors, and those who achieve a cumulative 3.8 or above for the first seven semesters graduate with highest honors.

Please note that Veracross rounds up a student's cumulative average on the transcript document to two decimal points. For example, if a student's true cumulative average was 3.796, on his transcript, it would appear as a 3.8. However, for the purposes of the designations for graduation noted above, DeMatha uses the true GPA. Thus the student in the example would graduate with high honors, not highest honors. Transfer students must have been a student at DeMatha for at least five of the first seven semesters in order to qualify for graduating with honors, high honors or highest honors.

PROMOTION

To be promoted to the next grade a student must earn passing grades in all his subjects. SHOULD A STUDENT INCUR THREE FAILURES FOR THE YEAR, HE MAY NOT RETURN THE FOLLOWING YEAR. FAILURES IN LESS THAN THREE SUBJECTS MUST BE MADE UP AT THE DeMatha SUMMER SCHOOL UNLESS THE COURSE OR COURSES ARE NOT OFFERED.

DIPLOMAS WITH DISTINCTION

Students who wish to earn a special diploma by pursuing concentrated studies in a specific content area may do so using the following guidelines:

Diploma with Distinction in the Humanities (English, Theology, Social Studies, Languages—currently 28 semesters required to graduate)

A student must successfully complete 33 semesters of work in the Humanities with a GPA of 3.8 or above.

Diploma with Distinction in Science and Mathematics (Science, Math, Computer Science—currently 15 semesters required to graduate, 16 with Health*)

A student must successfully complete 19 semesters of Science, Math, and Computer Science and Engineering with a GPA in these courses of 3.8 or above (a programming class is required.) A student may count a year of participation in Science Scholars, Science Club, Robotics Club, or ACE/Ecology as one semester of work.

*Health does not count towards this Diploma with Distinction

Diploma with Distinction in Arts (Music, Fine Arts—currently .5 semesters to graduate)

A student will achieve 11 semesters of successful Academic work in the Arts. The grade point average in these classes must be 3.8 or above. A student must take at least one academic semester in music and a fine art. Participation in a dramatic production or a year of Tri-M will count as one semester but cannot count as a semester of either music or fine arts.

FAILING GRADES FOR SENIORS AND GRADUATION

A senior failing 1, 2 or 3 courses during his senior year must make up these courses in summer school before being awarded a diploma. A student with 3 or fewer failures may participate in the graduation exercises; however, the diploma will not be awarded at that time. Seniors who fail more than 3 subjects will not be eligible for a DeMatha diploma and will be required to obtain the graduate status at another institution. Seniors with more than 3 failing grades at the end of the first semester will be required to withdraw from DeMatha at the conclusion of the semester. This policy is necessary so that the student will have the opportunity to graduate in June of his senior year and receive a diploma from another school. Any questions regarding this policy should be directed to the Director of Guidance.

ACADEMIC QUARTERS

1st Quarter:	August 24 - October 26
2nd Quarter:	October 30 - January 12
3rd Quarter:	January 16 - March 15
4th Quarter:	March 18 - May 31 (May 17 for Seniors)

REPORT CARDS

Report cards are published in Veracross after each quarter. The information on the report card includes grades and credits earned for each subject, a record of absences and tardiness, and the various Grade Point Averages for each quarter and semester. Parents can check student grades from their Parent Portal.

GRADE CHANGES AND INCOMPLETE GRADES

After approximately two weeks from the end of each quarter (see school calendar for specific dates), no grade changes will be allowed and all incomplete grades must be resolved. After that time, all I's may be converted to F's depending on the reason for the incomplete grade.

CLASSROOM VISITS BY PARENTS

Visits by parents to classrooms in which their sons are being taught are not allowed. In rare circumstances parents may be allowed to visit another section of the same course being taught, although this practice is discouraged as it can disturb the concentration of all the students in the class.

ELECTRONIC RECORDING BY PARENTS

Electronic recording, videotaping or taking of pictures of teachers during conferences, meetings or phone conversations without explicit consent is prohibited.

ACADEMIC PROBATION AND EXTRACURRICULAR INELIGIBILITY

Academic Probation is determined at the end of each report card period (first quarter; second quarter/ first semester; third quarter; fourth quarter/second semester/final grade) and goes into effect when a student meets the following criteria:

9th grade students:	3 failures or a GPA below 1.7
10th grade students:	3 failures or a GPA below 1.85
11th grade students:	3 failures or a GPA below 2.0
12th grade students:	3 failures or a GPA below 2.0
Transfer students:	10th grade students: a GPA below 1.75
	11th grade students: a GPA below 1.85
	12th grade students: a GPA below 2.0

In order to be placed on academic probation at the end of the first semester, a student must fall below the above criteria for **both** his second quarter his semester GPA's. In order to be placed on academic probation at the end of the year, a student must fall below the above criteria for his fourth quarter, his second semester **and** final GPA's.

Throughout the year, students who are on Academic Probation will be placed in a mandatory study hall during the school day for the entire quarter. Some students may be required to attend a difficult class twice instead of attending study hall. This restriction will only be lifted at the end of the quarter and then only if the student has successfully raised his GPA and reduced his number of failures to below three. Parents will be notified by email if their sons are on Academic Probation.

ATHLETIC EXTRACURRICULAR ACTIVITIES

Any student who is on Academic Probation will be allowed to try out for an athletic team. However, the following special restrictions will be placed on those students who are on Academic Probation and whom wish to participate on athletic teams. For all three sports seasons the following are in effect: 1. Players cannot dress for games. 2. Players cannot be on the sidelines. 3. Players cannot use school transportation on game days. 4. Coaches will inform players of AP and when it will be enforced. 5. Players are able to practice with their teams.

FALL SPORTS SEASON

1. A returning student who is on Academic Probation because of 4th quarter, second semester or final grades for the year last completed will be placed in a mandatory study hall for the entire first quarter. The set of grades (either 4th quarter, second semester, or final) which is most favorable to the student will be used to make this determination. If the previous year's final grades are the ones used in computing this GPA, summer school grades will be included. Some students may be required to attend a difficult class twice instead of attending study hall.
2. A returning student on Academic Probation can tryout, practice and play for a team for the first five weeks of the school year. On October 2, 2023 his status will be reviewed and if he has three F's or is below the GPA standard for his class (see above), then he will be ineligible to play for his team until the end of the first quarter. On the review date, on or about November 1, 2023, if he still has not improved his grades to meet the stated guidelines, he will be ineligible to play for his team for the rest of the season.
3. At the end of the first quarter the status of all players of fall sports will be reviewed on or about November 3, 2023. Any student who has three F's or is below the GPA standard for his class (see above) will be ineligible to play for his team for the rest of the season.
4. A student on Academic Probation may practice for his team at the coach's discretion at any time during the season.

WINTER SPORTS SEASON

1. Any student on Academic Probation because of his first quarter grades will be placed in a mandatory study hall for the entire second quarter. Some students may be required to attend a difficult class twice or go to the Academic Support Center instead of attending study hall.
2. When tryouts for winter sports begin on November 8, 2023, a student on Academic Probation may still try out for the team of his choice. However, if his status review on December 8, 2023 shows that he has not improved his grades to meet the stated guidelines, then he may not play for his team until the end of the first semester, but again, only if he has then improved his grades to meet the stated guidelines. At the review date, on or about January 22, 2024, either the second quarter grades or the first semester grades may be used; whichever are more favorable to the student. If he still has not improved his grades to meet the stated guidelines, he will be ineligible to play for his team for the rest of the season, should it end prior to the next review date, February 5, 2024. He may play for his team after this date if he has improved his grades to meet the stated guidelines.
3. At the end of the second quarter the status of all players of winter sports will be reviewed. Any student who has three F's or is below the GPA standard for his class (see above) will be ineligible to play for his team for the rest of the season, should it end prior to the next review date, February 5, 2024. He may play for his team after this date if he has improved his grades to meet the stated guidelines.
4. A student on Academic Probation may practice for his team at the coach's discretion at any time during the season.

SPRING SPORTS SEASON

1. Any student on Academic Probation because of his second quarter or first semester grades will be placed in a mandatory study hall for the entire third quarter. Some students may be required to attend a difficult class twice or go to the Academic Support Center instead of attending study hall.
2. When tryouts for spring sports begin on February 20, 2024, a student on Academic Probation may still tryout for the team of his choice. If his status review at the end of the third quarter on March 15, 2024 shows that he has not improved his grades to meet the stated guidelines, then he may not play for his team until the next review date, April 17, 2024, but again, only if he has improved his grades to meet the stated guidelines. If he still has not improved his grades to meet the stated guidelines, he will be ineligible to play for his team for the rest of the season.
3. At the end of the third quarter the status of all players of spring sports will be reviewed. Any student who has three F's or is below the GPA standard for his class (see above) will be ineligible to play for his team until the next review date, April 17, 2024, but again, only if he has improved his grades to meet the stated guidelines.
4. A student on Academic Probation may practice for his team at the coach's discretion at any time during the season.

HOCKEY

1. Since the above athletic activity occurs over a longer period of time than most sports, a somewhat different set of regulations will govern it. A student who is on Academic Probation because of his first quarter grades will be placed in a mandatory study hall for the entire second quarter. Some students may be required to attend a difficult class twice instead of attending study hall.
2. A hockey player will lose his eligibility if poor first quarter grades place him on the Academic Probation list. Should this occur, starting on November 3, 2023 he may not play for his team until his status review on or about December 8, 2023 shows that he has improved his grades to meet the stated guidelines. If he has not done so, then he may not play for his team until the next review date at the end of the semester, on or about January 22, 2024, but again, only if he has improved his grades to meet the stated guidelines. (At this juncture, either the second quarter grades or the first semester grades may be used; whichever are more favorable to the student.) If he still has not improved his grades to meet the stated guidelines, he will be ineligible to play for his team for the rest of the season.
3. A student on Academic Probation may practice for his team at the coach's discretion at any time during the season.

NON-ATHLETIC EXTRACURRICULAR ACTIVITIES

The penalties for a student on Academic Probation, who participates in a non-athletic extracurricular activity, shall be determined by the moderator of said activity. Such penalties should be in line with any national regulations governing that activity, if they exist, i.e. the National Honor Society.

The Principal has the final say in all matters of Academic Probation and Extracurricular Ineligibility, and may determine, in his discretion, that a student is eligible or ineligible despite the eligibility determination that would otherwise be called for using the foregoing standards.

FAILING GRADES

A grade of F is failing. Final grades are determined by grades achieved in the four quarters and the exams given at the end of each semester. Usually the first and second semester grades are averaged together to determine the final grade. In year-long courses the second semester grades sometimes carry more weight in determining the final grade. Other factors that enter into the determining of the final grade are:

1. A second semester grade of F can result in a failure for the year, at the discretion of the teacher.
2. A final examination grade of F can result in a failing grade for the year, at the discretion of the teacher. However, a student who has consistently passing grades and fails the final examination can be allowed to take a make-up examination, at the discretion of the teacher.
3. A teacher may determine that a student's failing performance in a course may require a more intensive summer program than our regularly scheduled summer school to obtain a passing grade for the course. The course of action taken varies for each department.

A student who fails three or more subjects at the conclusion of the school year may not return to DeMatha.

TEACHER SELECTION

DeMatha's management system, Veracross, selects teachers for all students. Neither parents nor students select teachers. However, if a student has been scheduled with a teacher he has already had, he may be granted a change in teachers.

SEQUENCE COURSES

Although a grade of D is passing, a student must achieve a grade of C in a sequence course in order to advance to the next year of the sequence.

School regulations stipulate that any failing grade must be made up in summer school. Students are also required to attend summer school if they meet one of the following criteria: A final grade of F in any class. A grade of D in a regular Algebra I or Algebra 2 class. A D in Honors Algebra I or Honors Algebra 2 does not result in required summer school. The student will drop out of the honors math program. A grade of D in the first two levels of a foreign language.

SUMMER SCHOOL

DeMatha operates a summer school program which opens during the latter part of June and closes in late July. The summer school provides accredited make-up courses in most academic subjects and certain enrichment courses.

Original credit for courses taken at other approved summer schools will fulfill graduation requirements, provided permission is first obtained from DeMatha's Counseling Center, a passing grade is obtained and the following time requirements are met:

One credit -- minimum of 120 clock hours

Half credit -- minimum of 60 clock hours

Summer school grades are not averaged with the grades already achieved. Summer school courses and grades are listed in a separate place on the student's permanent record card and count as a full credit when averaging a student's cumulative average for his career G.P.A. Summer School courses are not for original credit. Students whose final averages are below 60% may be required to repeat the entire course the following year instead of attending Summer School. Courses for grade improvement not taken at DeMatha Catholic High School will not be calculated into the student's GPA. A student cannot graduate with an F on his transcript unless it is made up in summer school.

DROPPING COURSES

Students wishing to change their program should contact the appropriate counselor in the Counseling Center. The Drop/Add date for year-long courses for the 2023 - 2024 school year is September 15, 2023.

The deadline for dropping first semester courses is September 15, 2023 and the deadline for dropping second semester courses is February 2, 2024. A year-long course (1 credit) may only be dropped at the first semester deadline. The exact dates are listed in the official school calendar. A student may drop a course after these dates only if in the opinion of the instructor and the counselor he is unable to succeed due to a lack of ability or an error in academic placement. A student whom drops a course after these dates because he is failing the course (not due to lack of ability or an error in academic placement) will have the notation "withdrew failing" put on his transcript next to that course.

TRANSFER PROCEDURES

A student wishing to transfer from DeMatha must first contact his counselor. A letter requesting the transfer must come from the student's parent or guardian. Transcripts will be forwarded to the new school upon receipt of an official request from the school, but only if all financial obligations have been satisfied and all school materials such as library books, athletic equipment, etc. have been returned.

Official transcripts may not be given directly to parent or student to carry to the new school.

SCHOOL RECORDS

Parents may request to see the student's academic records at any time. Please make an appointment to do so in order that a counselor may be available to assist in interpreting the record. (See Appendix G) for a sample of an academic permanent record)

SIGNIFICANT ACADEMIC ASSESSMENT SCHEDULE

Each department has a day assigned for major assessments given during a quarter. As a guide, assessments such as major tests, "quests", etc. covering material that could not be studied in a normal evening's homework time should be given only on the assigned assessment day. Major papers and compositions count as significant assessments and should be assigned to be due on these dates as well.

Assessment Days

A day and B day	English, Business
C day and D day	Science, Theology
E day and F day	World Languages, Social Studies
G day and H day	Math, Health, Fine Arts

Alternate Assessment Days

E day and F day	English, Business
G day and H day	Science, Theology
A day and B day	World Languages, Social Studies
C day and D day	Math, Health, Fine Arts

Students who have **more than two major assessments** on a given day must see Mr. William Clark **in advance of that day** if they want to reschedule any of them. Students are not excused to go to sectionals on days they are scheduled for labs or major tests. Faculty members with reconcilable conflicts should also see Mr. Clark

Some students have documentation indicating a need for extra time on quizzes and tests. The Counseling Center in consultation with the Academic Support Specialists will respond to any accommodation requests.

RETAKE POLICY FOR MAJOR TESTS

Whenever a student misses a major subject test (full period test) for legitimate reasons (excused absence) and in the teacher's judgment the test must be re-scheduled, this will be given on the Saturday morning (9:00 a.m.) after the student's return to school. A fee may be charged. The test will be prepared by the subject teacher and proctoring will be scheduled by the Dean of Students. It is the teacher's prerogative to schedule the test on Saturday or to proctor it himself/herself.

Students who fail to take a scheduled major test without being properly excused may receive an F (zero).

FINAL EXAMINATIONS

At the conclusion of the second semester, four days are scheduled for final examinations. These examinations are an important part of the student's performance in the class and may contribute from 1/5 to 1/3 of the semester grade. Classes are not scheduled during these days, and students come only for their examinations. Usually no more than two examinations are scheduled on one day. **Students are to be in full uniform for all examinations and are expected to be on time. If a student misses an exam for any reason, it is that student's responsibility to contact the teacher involved to arrange for a make-up exam if one is warranted.**

Cancellation of school due to snow or other emergencies:

In the event that some emergency requires the cancellation of school during one of the examination periods, the cancelled examinations will be given on the next school day following the cancellation. If more than one day is missed in succession due to an emergency, the first day back in school will be for the first examination day missed. **THE SEQUENCE OF THE EXAMINATIONS WILL NEVER CHANGE.** For example: If on Tuesday school is cancelled, the examinations scheduled for Tuesday will be given on Wednesday. If both Tuesday and Wednesday are cancelled, then Tuesday's exams will be given on Thursday, and Wednesday's exams will be given on Friday. The regular sequence of exams then continues until all examinations are taken. If, in the event that a successive number of cancelled days extend beyond the examination week, the missed exams may be cancelled.

Delayed Opening due to emergencies:

If during examinations the school has a delayed opening due to some emergency, all examinations given on that day begin one or two hours later than originally scheduled. This will be announced on Parent Alert and the school's website.

ACADEMIC AWARDS NIGHT

Our annual Academic Awards Night honors students for outstanding academic success during the school year. All students who have been on the Honor Roll, Academic Dean's List, or Principal's List for three consecutive quarters (**first quarter, first semester and third quarter**) are awarded lapel pins. Special awards are given to seniors graduating with honors (a cumulative 3.0 average) and with highest honors (a cumulative 3.8 average). Students who have achieved excellence in a variety of other academic pursuits also receive recognition.

MATERIALS FEE

The following courses may include materials fee paid in class or billed to student:

Business Law/Personal Finance

Business Topics 1

Health

Economics

All Art courses

All Photography courses

In order to defray the cost of providing Independent Studies courses, an additional fee will be charged (\$800.00 for a full year course, \$400.00 for a one-semester course). This fee will be split equally among the students enrolled in the course.



THE COUNSELING CENTER

THE COUNSELING CENTER

The Counseling Center seeks, in every way possible, to be a source of help to the whole DeMatha family--students, teachers and parents. Its role is to act as a facilitator in the process of education, taking into account the multi-dimensional nature of both the learning and the teaching process.

The Center seeks a) to work with the student, his parents and teachers each year to develop the best possible academic schedule that will match his abilities in each subject and challenge him to learn more about that subject; b) to assist the student in attaining maximum personal and intellectual growth; c) to assist him to effectively handle personal and/or inter-personal problems; d) to help him to make a realistic evaluation of his interests and goals; e) to help him adjust to school life and expectations; and f) to assist in the multi-faceted process of preparation for post-secondary education.

Students and parents are encouraged to contact counselors at any time during the school day. Students are assigned counselors for academic purposes, but may choose any counselor when seeking help for personal issues.

The ultimate goal of the Counseling Center is to help the student to overcome any obstacle which might interfere with his successful education at DeMatha and to help him feel secure about his goals and plans for his post-secondary pursuits.

To this end, the Counseling Center engages in several types of counseling:

1. **Academic:** When students choose their courses for the following year, they discuss the choices with their counselor who may make suggestions in light of the students expressed goals. In addition, when a student is experiencing difficulty with a particular subject or instructor he should contact his counselor. A meeting may be recommended by the faculty member, parent or the counselor.
2. **Educational and Career Planning:** Information on hundreds of career and educational institutions is available in the Center. A computer program is also available to each student. This program begins with a personality test that will then be used to discuss personal strengths and interests and how these may be matched to colleges and careers. Students are encouraged to make use of the various resources in the Center and are encouraged to talk with their counselor concerning their educational plans and career options.

While the counselors will talk with each student concerning their goals at regular intervals, the students are always encouraged to initiate these meetings and to make use of the resources as often as needed.

3. **Personal:** Many times there are issues not directly related to education that provide an obstacle to success at school. Some of these may include: personal problems, issues involving things such as home life, friends, substance abuse, human sexuality, or any number of other things. Students should feel free to discuss problems of this nature with any of the counselors.

Confidentiality is an important aspect of the relationship the student and counselor develop in the areas of personal life and its possible problems. The counselor will maintain this confidentiality unless the fear of injury to the student or to others becomes real. In these cases the counselor will discreetly assist the student in a manner which will protect all those involved regardless of confidentiality rules that apply in other situations.

4. **Standardized Testing and Interpretation of Results:**

The Counseling Center administers batteries of aptitude, achievement and interest surveys in order to help students plan their futures on the basis of proven competency and ability.

STUDENT RECORD KEEPING

The official educational data on every student is maintained in perpetuity in the Counseling Center. This includes identifying data, birth date, final grades for academic work completed, standardized test results and attendance data. To ensure the privacy of a student and his family, written authorization is required from either the student himself if he has reached 18 years of age or from his parent/guardian for release of information to any other interested parties. Parents may request the release of transcripts to college coaches in order to complete applications for college athletic scholarships. A file is maintained recording the name and title of anyone requesting student information from school records. The date that this information is sought is also recorded. Faculty members have access to the records of those students in his/her classes. Parents may view their son's records by requesting an appointment with his counselor. The transcript on each student will be completed by July 31 of each year.

DISCLOSURE POLICY

In accordance with the principles of NACAC (The National Association of College Admissions Counselors), it is the policy of DeMatha Catholic High School to notify colleges of serious infractions resulting in probation, suspension or dismissal. If asked specifically, we respond truthfully and candidly about disciplinary action. We reserve the right to report any violation which may occur during senior year. If a student's academic or citizenship standing changes substantially at any time during the senior year, we will notify colleges. We expect and counsel students to provide colleges with an account of what occurred and how they have been affected as a result.

CONFIDENTIAL REPORTING BOX

Students, faculty or staff that have concerns about any aspect of school life can report those concerns in writing through the box located in the Counseling Center. DeMatha also encourages anyone with concerns about safety or health to report those concerns to an administrator immediately. These reports can be made confidentially and/or anonymously.



STUDENT PROCEDURES AND REGULATIONS



STUDENT PROCEDURES AND REGULATIONS

Introduction

DeMatha is vitally interested in the good behavior of its students both in and out of school. Each student is part of the school's identity, just as the school is part of his. A student should consider, therefore, that his actions affect not only his own reputation and that of his family, but also the reputations of many others who are likewise identified with DeMatha Catholic High School -- fellow students and their parents, faculty and administration, alumni and friends. Thus, we advocate that every student manifest "good behavior" within the school community, as well as the larger societal realm.

However, how does one define "good behavior"? Let it not be thought of simply as the avoidance of poor behavior. Rather, it is a series of conscious, positive actions based on 1) a fundamental understanding of right and wrong, and 2) respect for the rights and property of others. Viewed in this manner, good behavior will always be beneficial, not only to the individual student, but also to the society in which he lives.

The responsibility to maintain and promote the excellent reputation that DeMatha enjoys rests on each individual student and can be realized when a student includes in the educational process a goal that will maximize his growth through the practice of good behavior. Basic to every person is the inherent ability to distinguish between right and wrong.

With the above thoughts in mind, the following procedures and regulations are put forth to help ensure the orderly and effective functioning of the school and the achievement of its stated objectives. Registration at DeMatha presumes acceptance of and cooperation with these procedures and regulations both by students and by parents or guardians. Further, the school reserves the right to establish additional regulations that might be deemed necessary to maintain effective order in the school.

Realizing that an all-inclusive listing of disciplinary offenses would be impossible to outline and describe on these pages, the school will take appropriate disciplinary action for any offense that, in the opinion of the administration, violates the good behavior expected of a student or is inconsistent with Roman Catholic principles, values and morals. Thus, disciplinary action may be taken for infractions that are not listed here. Additionally, depending on the facts and circumstances involved, DeMatha may, in its sole discretion, determine that an infraction warrants more severe disciplinary action than that which would otherwise be called for here. A DeMatha student is subject to disciplinary action twenty-four hours a day seven days a week if his behavior and conduct is detrimental to the school and its reputation.

I. NON-EXHAUSTIVE LIST OF DISCIPLINARY VIOLATIONS.

The following is a non-exhaustive list of disciplinary infractions, carrying potential penalties of detention, probation, suspension, and expulsion depending on the severity and circumstances of the offense.

A. **SERIOUS OFFENSES** -- certain breaches of school discipline may result in immediate probation, suspension or expulsion from DeMatha:

1. OFFENSES ORDINARILY RESULTING IN IMMEDIATE DETENTION, PROBATION, OR SUSPENSION

- a) Leaving school grounds without permission during school hours.
- b) Irresponsible use of a motor vehicle on or near school grounds, including loud auto radio or stereo music.
- c) Truancy or skipping of class.
- d) Frequent tardiness.
- e) Continued disregard for dress and grooming regulations.
- f) Improper signature on any school forms or correspondence (i.e. absentee notes, etc.).
- g) Gambling or card playing.
- h) Damage to a neighbor's property.
- i) Defaming DeMatha's name or reputation by improper behavior at any time.
- j) Damaging, misusing, or destroying school property.
- k) Violation of the Computer Network Code of Ethics and DCHS Internet Policy (Appendix E).
- l) Accumulation of 18 demerits.
- m) Repeated confiscation of electronic devices.

- n) Fighting or Slap Fighting. Game playing or smacking, tapping, playing around which includes unwanted contact as a result of game playing. Failure to keep hands to yourself.
- o) Discourtesy and/or disrespect to a faculty or staff member.
- p) Failure to report to a teacher's office or for detention (after school or Saturday detentions) as directed.
- q) Failure to properly identify oneself to a faculty or staff member.
- r) Possession or use of a laser pointer, rubber bands, paper horns, or any other type of projectile that causes harm, pain or class disruption.
- s) Use of vulgar, obscene or derogatory language directed at others.
- t) Taking of backpack, damaging, hiding or turning a backpack inside out.
- u) Failure to maintain cleanliness of school grounds, including parking lots, bathrooms and cafeteria.
- v) Continual uniform and hair violations.
- w) Making derogatory comments about the faculty, staff, alumni, parents and students of DeMatha Catholic High School, including on the internet or any social networking site. Note, creating false accounts on any social networking site is itself a punishable offense.
- x) Taking pictures of faculty, staff and other students without consent.
- y) Any disruptive behavior on campus, e.g., participating in water balloon fights, snowball fights, food fights, squirt gun or bottle fights, and large group gatherings of 8 or more students creating a disruption.
- z) Any unauthorized use of DeMatha's name or logo, for example, use on social networking sites or as part of a fundraising solicitation without preapproval of the school.
- aa) A student who repeatedly violates the school grooming or uniform policy may receive a minimum of one Saturday detention per violation. This student may also be suspended for repeated uniform or grooming violations. This is not the same as receiving demerits for minimal uniform or grooming violations.
- bb) Students who are caught unsupervised in the locker room (loitering) before, during or after school will receive a Detention.
- cc) Students or parents ordering outside food for delivery to school.
- dd) "Pressing Out" or any physical misconduct between individuals playing around, or not, will result in a 2-day suspension and probation 2 for the first offense and a disciplinary review hearing on the second offense.
- ee) "Cutting" of eye brows and intentional refusal to comply with the school uniform regulations, including hairstyles and shaving will result in an immediate 2-day suspension and Probation 2.
- ff) Videos or Snap Videos without authorization on campus may result in suspension or further disciplinary review.
- gg) Students who steal food from the cafeteria; including adding food to their tray, touching food without authorization or touching food they are not going to buy, may be suspended from DeMatha and placed on Probation 2 and lose cafeteria privileges.
- hh) Students who are dishonest to a faculty or staff member.

2. OFFENSES ORDINARILY RESULTING IN EXPULSION:

- a) Stealing; keeping of lost property.
- b) Possession, use or distribution of drugs; consumption or possession of vape pens or vaping devices; E Cigarettes, tobacco or tobacco products; alcohol and/or paraphernalia associated with drugs, vaping, E Cigarettes, tobacco or alcohol on school property or at school activities. A student who is suspected of alcohol use or observed to act in a manner that resembles that of a student who is intoxicated or who smells of alcohol will be removed from any DeMatha event. For the safety of students at school related functions, DeMatha reserves the right to administer an alcohol test to any student suspected of drinking prior to or during any DeMatha-related function.
- c) Possession or use of any weapon or facsimile of any weapon or illegal instruments (e.g. guns, pellet guns, starter pistols, throwing stars, knives, nunchakus, etc.) will be treated as a weapon. Students must inform school authorities if they have any knowledge of weapons in the school.

- d) Possession or use of fireworks of any kind (e.g. fire crackers, snappers, smoke bombs, bottle rockets, etc.)
- e) Any act endangering the welfare and wellbeing of others; (e.g. pulling a fire alarm, turning lights off, dialing 911 and hanging up, etc.).
- f) Bullying and harassment: Any mistreatment, act or implied act of physical, emotional or psychological intimidation or sexual harassment directed at a faculty/staff member or student by statements or actions (e.g., in writing, orally, drawings or graffiti, inappropriate gestures, inappropriate touching, physical contact, etc. including ALL social media.)
- (1) **Definition:** In accordance with the provisions of section 7-424.1 of the Education Article of the Annotated Code of Maryland, the Maryland State Board of Education has developed and adopted the following Model Policy to address bullying, harassment, or intimidation as it now relates to non-public schools in the State of Maryland. As used in this policy, “bullying, harassment, or intimidation” means intentional conduct, including verbal, physical, or written conduct or an intentional electronic communication that creates a hostile educational environment by substantially interfering with a student’s educational benefits, opportunities, or performance, or with a student’s physical or psychological well-being and is: *motivated by an actual or a perceived personal characteristic including race, national origin, marital status, sex, sexual orientation, gender identity, religion, ancestry, physical attributes, socioeconomic status, familial status, or physical or mental ability or disability; or, threatening or seriously intimidating; and occurs on school property, at a school activity or event, or on a school bus; or substantially disrupts the orderly operation of a school. “Electronic communication” means a communication transmitted by means of an electronic device, including a telephone, cellular phone, or any other type of electronic device. This policy recognizes that the prohibition of bullying in schools and the reprisal and retaliation against individuals who report acts of bullying, as well as subsequent and standard consequences and remedial actions, cannot be effective as prevention and intervention methods unless they are included as part of a whole-school prevention/intervention program.
- (2) **Consequences:** DeMatha Catholic High School has a zero tolerance policy with regards to bullying and harassment. When a report of bullying or harassment is filed, there is an immediate investigation into the incident. The victim is immediately counseled and all parents are notified. Once there is a determination of bullying and/or harassment, appropriate action is taken. The result may require a Disciplinary Review which may result in Expulsion from DeMatha Catholic High School.
- (3) **Procedures:** **If a student reports that he is currently the victim of bullying, harassment, or intimidation, the staff member will respond quickly and appropriately to investigate and intervene, as safety permits. If a student expresses a desire to discuss an incident of bullying, harassment, or intimidation with a staff member, the staff member will make an effort to provide the student with a practical, safe, private and age-appropriate way of doing so. Bullying and Harassment, or intimidation reporting forms may be obtained in various offices throughout the building and online on the DeMatha web site.**
- Reports of bullying and harassment should be written using the reporting form.
 - School Administration will investigate and determine if the bullying, harassment or intimidation has occurred.
 - Parents are immediately notified and subsequent action will proceed.
 - Administration will determine if a criminal investigation is necessary or if the situation should be turned over to authorities to pursue the report as a delinquent act.
- All victims of bullying, harassment or intimidation are counseled and protected.**
- g) Repeated incidents of academic dishonesty (Appendix B).

h) Hazing:

(1) Definition: any conduct or method of initiation into any student organization or team, whether on public or private property, which endangers the physical or mental health of any student or another person. Such conduct includes whipping; beating; branding; head shaving; forced calisthenics, forced consumption of any food, beverage, drug or other substance; or any treatment or forced physical activity that is likely to adversely affect the physical and or mental health or safety of any student or other person.

(2) Where and when policy applies: This policy applies to behavior that occurs on or off school property and during and after school hours.

i) Violation of probationary status.

j) Accumulation of 24 demerits.

k) Any offense listed under paragraph 1 of this section, which the School determines warrants expulsion based on the facts and circumstances involved.

l) Misconduct or actions which are inconsistent with Roman Catholic values and morals.

PLEASE NOTE: The administration of DeMatha Catholic High School reserves the right to search anything brought on school property including but not limited to the search of persons, electronic devices, lockers or cars, when and if there is reasonable cause to warrant such a search.

B. DISCIPLINARY ACTIONS-- When a student or a group of students have committed any of the foregoing offenses or acted in a manner inconsistent with the intended spirit of these statements, the good behavior expected of a student, or Roman Catholic religious principles, values and morals, disciplinary action may be taken in the discretion of the Dean of Students' and Assistant Principal.

1. The Individual Teacher -- Individual teachers may deal with disciplinary problems without referral to the Dean of Students Office by assigning a task or giving an after school detention to a student or group of students.

2. If the Dean of Students Office is consulted, the disciplinary actions of demerit, Saturday detention, probation, suspension and expulsion are used.

a. Demerit: A demerit is given by faculty and staff members to students who violate a Procedure or Regulation or act in a manner that is inconsistent with the spirit of these statements or Roman Catholic religious principles, values and morals. In such a case, a demerit slip or notification is turned in to the Dean of Students' Office and the situation is noted on the student's disciplinary record. An accumulation of 6 demerits will result in a 3 hour Saturday Detention.

b. Work Detail: Students may be required to perform School service hours at the Dean's discretion. Students performing service hours may be required to wear appropriate clothing.

c. Detention: A student can be given a Saturday Detention or Work Detail not only as a result of accumulating 6 demerits but also in any other situation where it is determined that the student's behavior or conduct merits a Saturday Detention. A student who receives a Saturday Detention must report to school at 9:00 a.m. on the Saturday designated by the Dean of Students and will be released at 12:00 noon. He may only do work that relates to his classes unless otherwise instructed. The student will be obligated to pay \$20 (cash, check or money order payable upon arrival at the Saturday detention) to the school to defray the costs of proctoring the detention. The detention fee may be increased for chronic offenders.

If a student is unable to serve a designated detention because of illness or some other serious reason, his parent/guardian must notify the Dean of Students prior to the closing of school on the Friday before the detention is to be served. Detentions cannot be postponed for athletic games, practices, or other extra-curricular activities. If the illness or excuse was unknown prior to the closing of school on the Friday immediately preceding the date detention was to be served, when the student returns to school, he is to present a written excuse from his parents stating the reason for missing the detention. In such a case, the detention will be rescheduled for the following Saturday.

Please note: Under no circumstances can after-school work, etc. be substituted for a Saturday detention.

Failure to attend a Saturday detention without proper notification or excuse may result in a double fee, rescheduling of the detention, and/or suspension from school until a conference with the student, his parent(s) and the Dean of Students is held to discuss the missed detention and appropriate discipline.

Students who are assigned to detention are expected to be prompt.

- d. Probation: Students who exhibit poor behavior may be placed on Probation 1 or Probation 2 status, depending on the nature and circumstances of the violation. Parents will be notified from the Dean of Students explaining the reason(s) for probation. If probation is violated, the student may be suspended or expelled without any further hearings or disciplinary conference.
1. Probation 1: Students who engage in any misconduct listed in Section A and are placed on Disciplinary Probation 1 will remain on probation for a time determined by the Dean of Students. Violation of Probation 1 will result in the student being placed on Probation 2 or possibly being suspended or expelled from school.
 2. Probation 2: Disciplinary Probation 2 is for more serious violations of school rules or violations of Probation 1 and remains in effect for one full calendar year. Students violating this status are subject to expulsion from school without any further hearings or disciplinary conference.
- e. Suspension: Students who engage in any misconduct listed in Section A or other serious misconduct or misconduct while on probation may be suspended. If suspended, a student is excluded from class attendance and school activities for a maximum of three days. During this time, it is mandatory that the student and his parents meet with the Dean of Students during school hours to discuss the problem. It is the responsibility of the student to make up any work missed during the suspension period. It is at the teacher's discretion to provide make-up work for the student on suspension. In addition, a suspended student may be required to serve three Saturday detentions upon his return to school.

Students, at the discretion of the Dean of Students, may be given an in-school suspension for a maximum of three days. During this period the student is assigned to the in-school suspension room for the duration of the regular school day. Students may leave the room only for a normal lunch break, according to his daily schedule, as well as for necessary visits to the restroom. Students may not attend school events or mandatory school activities except for liturgies or mass. During the in-school suspension period students must complete each of the teacher-prepared assignments. Students receiving an in-school suspension will also be required to serve up to three Saturday detentions in addition to the in-school suspension.

- f. Expulsion: A student may be expelled from school for serious misconduct; if he has manifested a persistent unwillingness to abide by the Procedures and Regulations; or if his conduct is determined by the School to be inconsistent with Roman Catholic principles, values and morals. The decision of whether to expel a student rests with the Principal or his designee.
- g. Disciplinary Committee: The School's Disciplinary Committee will review any disciplinary cases where the punishment of expulsion is being considered. The Disciplinary Committee may also, in the Assistant Principal or Dean of Students' discretion, be called upon to review cases where expulsion is not being considered. The Disciplinary Committee is chaired by the Assistant Principal and Dean of Students and consists of at least five other members of the faculty or Administration. The Disciplinary Committee reviews the facts and circumstances of an infraction and recommends whether the student should be disciplined and, if so, what discipline the Committee believes the student should receive. The student will be given the opportunity to address the Disciplinary Committee in person. The student's parents or representative of the student or his parents will not be permitted to address the Disciplinary Committee. If a student violates school policy and regulations in such a manner that requires a hearing before the Disciplinary Committee, he may be placed on suspension pending hearing. If a student fails to appear for his Disciplinary Committee hearing, the Disciplinary Committee will proceed to review the case without the student's presence or input and the student waives any right to address the Disciplinary Committee.

The authority to expel a student rests in the sole discretion of the Principal or his designee, who acts in consultation with and considers the recommendations and findings of the Disciplinary Committee, but is not obligated to accept or adopt these findings.

If a student or his parents or guardians wish to appeal the decision of expulsion, the appeal must be made in writing. If the Principal made the decision to expel the student, the appeal is addressed to the President of the school within five days of receiving notice of the expulsion. The decision of the President is final. If another designated person has made the decision to expel the student, the first appeal is addressed to the Principal of the school within five days of receiving notice of the expulsion. If the student or his parents or guardians still do not agree with the appeal decision by the Principal, then the student or his parents or guardians issue a second letter to the President within five days of hearing the decision of the Principal. The decision of the President is final.

- h. Graduation Ceremonies: A senior may lose the privilege of participating in any of the end of the year activities (prom, Baccalaureate Liturgy, Commencement, etc.) due to a serious violation of school regulations.

II. RESPECT FOR THE RIGHTS AND PROPERTY OF OTHERS

In General: Basic to the full development of a Christian gentleman is the appreciation of and growth in virtue. The school administration, therefore, highly extols:

A. COURTESY

1. Students are expected to behave as Christian gentlemen at all times. Incidents of vulgar language, rowdiness, punching, running, whistling, shouting, disruptive behavior, discourtesy and lack of respect for fellow students, faculty and staff will not be tolerated.
2. For health and safety considerations, students are not permitted to smoke, chew, snuff or vape tobacco. Students representing DeMatha as members of a school organization are prohibited from use of tobacco during any school function on or off school property. The first violation of this rule will result in a Saturday detention; second violation, probation; third violation, expulsion.

B. RESPONSIBILITY:

1. Students riding bicycles to school must park the bicycles in the area provided. The school is not responsible in the event bicycles or bicycle parts are stolen or damaged.
2. Good manners are the rule in the cafeteria. When finished with lunch, students should dispose of all paper, wrappings, bottles, cans etc. in proper receptacles and replace chairs. A student will be given cafeteria duty for a period of time by the proctor if he fails to maintain hygienic conditions in the cafeteria

REPEATED OFFENSES MAY RESULT IN HIS BEING DENIED THE PRIVILEGE OF USING THE CAFETERIA.

3. Food and drink are prohibited in any area of the school buildings (Science labs, Technology labs, Media Center etc.) except in the cafeteria, mezzanine/Snack Bar area or in those areas specifically permitted by teachers and staff. Faculty and staff may confiscate the food and drink and further disciplinary action may be taken for the violation of this regulation. Items purchased in the vending machines must be consumed outdoors or in the cafeteria. The school discourages students from going to area stores to purchase food after school has ended. However, if food and drinks are purchased from these stores they cannot be brought back into the buildings, including the cafeteria which will be closed for cleaning. The school does encourage students to use the DeMatha Snack Bar for after school food and drink. This is in large part a safety issue.
4. Students who steal food from the cafeteria; including adding food to their tray, touching food without authorization or touching food they are not going to buy, may be suspended from DeMatha and placed on Probation 2 and lose cafeteria privileges.
5. During fire and emergency drills students are to follow their instructors and quietly leave the building according to the exit plan displayed in the classroom.
6. A great deal of potentially dangerous and very expensive equipment is contained in the science laboratories. Students must take extra caution when scheduled for classes in these rooms. Students who engage in horseplay or are careless in any of the science classes or on science class field trips will be subject to severe disciplinary action. In addition, financial restitution must be made if any lab equipment is damaged as a result of horseplay.
7. A student may not place a phone call from his cell phone anytime other than in an administrative office or with permission from a faculty or staff member. Consequently, each teacher and teacher's classroom are subject to their specific rules with regards to using a cell phone or electronic device. This rule is written in the teacher course policy sheet.

8. Cell Phone and Electronics Policy:

Cell phones, iPad's, Tablets and any other electronic device may not be used in hallways during the changing of classes; may only be used in the cafeteria, outside any building or only with the permission of a faculty or staff member. If a student must use their electronic device, he may use it in any administrative office or faculty office throughout DeMatha's campus or in a classroom only with the teacher's permission. At no time should a student be playing games during class, watching videos or using social media.

The penalty for misuse or unauthorized use of an electronic device is the following:

1st Offense: Phone is confiscated and put into the Dean's Office. The phone is returned at the end of the day and the student is required to pay a \$5 fine. Failure to pay the fine will result in the phone being confiscated the next school day until the fine is paid. A "first offense" notification will be made in Veracross.

2nd Offense: Phone is confiscated and put into the Dean's Office. The phone is returned at the end of the day and the student is required to pay a \$5 fine. Failure to pay the fine will result in the phone being confiscated the next school day until the fine is paid. A "second offense" notification will be made in Veracross.

3rd Offense: Phone is confiscated and put into the Dean's Office. The phone is returned at the end of the day and the student is required to pay a \$5 fine. Also, the student's phone will be "suspended" for the next 5 days and he will be required to bring his phone to the Dean's Office at 8:00 a.m. and the phone will be returned at the end of the day. A "third offense" notification will be made in Veracross

4th Offense: A meeting with the parents and the Dean's Office will be required.

The cell phone policy resets at the end of each semester.

A student may not wear earbuds or headphones at any time in a building on the DeMatha campus unless given permission. Students may not make phone calls in any building or common space, including the cafeteria unless given permission.

At no time is a student permitted to remove the SIM or memory card from an electronic device that is confiscated. Saturday detention will be given for repeated misuse of a cell phone or inappropriate use of iPads, laptops and other types of e-readers. Cell phone charging is by permission only in offices and classrooms. If a student receives more than three offenses for repeated misuse of electronic devices, the school reserves the right to keep the device until the end of the quarter or semester and the student could face suspension or disciplinary review. (Refer to Appendix E)

III. CODE OF CONDUCT FOR BUSES

Bus transportation is provided by DeMatha Catholic High School through contracts(s) with private vendor(s) or with DeMatha bus(s). Bus transportation is an extension of the DeMatha school day. The school Code of Conduct extends to all school bus transportation. Proper behavior begins at the point of entry on any bus and continues until departure.

Infractions of the School Code of Conduct and School Policy(s) will be reported to the school and will result in disciplinary action by the school. The bus drivers have a dual responsibility: 1) to operate the bus in a safe manner, and 2) to report infractions to the school. They are to be respected in the same way as school faculty. If a student is disciplined for any transportation infraction, the parents will be responsible for payment of all fees for transportation services. There will be no refund if a student is removed from participation in the transportation program.

IV. ATTENDANCE

As part of the Philosophy of Education at DeMatha Catholic High School, attendance is a critical component for academic achievement and success. Class days are noted on the school calendar and regular attendance is required. Students are expected to be in school and on time on all days when school is in session. Student attendance records become a part of the high school permanent record that is transmitted to other institutions or employers when a student leaves DeMatha. It behooves a student to make every effort to avoid absences from school and tardiness to class. **Unless they are a result of a school sponsored activity, absences in excess of 16 times per year (or 8 times per semester) may result in the student's loss of credit regardless of the grade received in the course.** This will be determined by the teacher in conjunction with the school administration. Health related factors will be addressed on an individual basis.

PLEASE NOTE: A student must make up any work missed during an absence whether excused or unexcused. Absence from a school day may exclude a student from participation in any extra-curricular activity scheduled for that day or evening.

A. EXCUSED ABSENCE AND LATENESS

An absence or tardy to school or class may be excused with a phone call, note, or email sent to the Attendance Office (240-764-2230, attendance@dematha.org). This applies to illness, school related events, some weather conditions, death in the family, court appearance, or college visit (Seniors or Juniors only). Traffic, even with notification, is not considered excused. Students out sick for 3 or more days must provide a doctor's note.

Absence Procedure

1. A parent or guardian must call the school at 240-764-2230 before 11:00 a.m. on the morning of the absence.
2. A note must be submitted to the Attendance Office on the day of the return. The note must specify the date and cause of the absence and must bear the signature of a parent or guardian.

PLEASE NOTE: Excused absences for illness will still be reported as a day missed from school within the Veracross system (unexcused), but these absences will not result in any academic penalty.

Credit for Missed Work

Parents whose sons will be out of school for 3 or more days should call the Counseling Center and the Attendance Office concerning the work the student is missing. If a student will be absent for fewer than 3 days due to illness, the student should contact his subject teachers concerning the missing work. If a student is absent from a comprehensive examination for a reason which is approved by Administration and/or his teacher, then he must take the exam on the assigned make-up day.

B. EXCUSED DISMISSAL

An early dismissal or late arrival to school may be excused due to illness and medical/dental appointments. Medical and dental appointments should be made to the extent possible outside regular school hours. Regardless of excusal, students must obtain the express permission of the Attendance Office prior to leaving campus.

Illness

Students must report to the Attendance Office unless it is a life threatening emergency. If the student's condition warrants his being released from school, parents will be called to obtain permission for release. If a parent cannot be reached, a decision on the release of the student will be made by the administration. If released, the student must call the school immediately upon his arrival home.

Training Room

A student is not permitted to go straight to the training room due to illness. Attendance Office staff will make the determination whether to send a student to the training room or send a student home. A student who fails to check in with the Attendance Office and misses a class as a result, will be considered truant. Students may not use the training room as an excuse to miss class time.

Early Dismissal

Planned dismissals require a written request from a parent or guardian or a faculty member specifying the purpose and length of any time of absence. Students who leave school prior to notifying the Attendance Office and receiving permission are considered truant.

1. **Medical/Dental Appointments:** A written request signed by the parent or guardian that includes the date and time of the appointment must be submitted to the Attendance Office.
2. **Vacations:** The school calendar provides ample number of holidays during the school year to allow leisure time activities. Consequently, the school will not grant permission to extend a vacation or to take a special vacation unless the circumstances are extraordinary. In those cases, parents must present a written request, but the school reserves the right to refuse to allow the leave and impose sanctions.

C. UNEXCUSED ABSENCE

An unexcused absence is recorded if the Attendance Office does not receive communication from a parent or guardian of the student. Communication from a parent or guardian must be with a phone call, note, or email sent to the Attendance Office (240-764-2230, attendance@dematha.org). A teacher has the right not to accept/assign make-up work if a student's absence is unexcused. The term "unexcused" does not define a student as truant from school.

D. LATENESS

1. Lateness to School

A student is considered late to school if he is not in his assigned classroom when the bell rings for his first class of the day. To participate in any extra-curricular activity a student must be in school and signed in prior to 10:30 a.m.

2. Lateness to Class

A student in school is considered late to class if he is not in his assigned room when the bell rings marking the beginning of the period. Each teacher may define the academic consequence of the tardiness in his or her course expectations sheet. Lateness to class not only disrupts the class lesson for the day (lecture, quizzes, tests and labs), but directly impedes the academic progress of the student and is thus much more serious. Additionally, the teacher may take academic consequences that may include academic penalties that are at the discretion of the teacher. No makeup work, notes, quizzes or tests, may be given as a result of an unexcused lateness to class. Excessive tardiness to class may result in prohibiting students from participating in class field trips or other after school activities. Without proper excuse, disciplinary action will be accessed.

Students late to class more than 7 occasions will enter a progressive disciplinary sanction:

1st Offense: Student must report to Dean's Office upon notification in order to receive an after school detention. (8 unexcused lateness to class).

2nd Offense: Student must report to Dean's Office upon notification in order to receive an after school detention. (8 additional unexcused lateness to class – 16.)

3rd Offense: Student must serve a Saturday detention upon notification. (8 additional unexcused lateness to class - 24.)

Specific Strategies Used to Promote Attendance

- A. Attendance is taken at the beginning of each school day during the first period of instruction.
- B. Attendance is also taken by all teachers at the beginning of each scheduled class or study hall through the course of the day.
- C. Attendance is taken by all teachers during class assemblies, school field trips and retreats etc.
- D. Once a student arrives at school in the morning, he may not leave the campus until the school day is over without permission from the Attendance Office.
- E. A student whose parent expects him to be in school and does not attend for any reason is considered truant (unexcused).

Student attendance and disciplinary sanctions to be used to discourage unexcused tardiness.

- A. Students late to their first class of the day are tardy and must report to the Attendance Office or an Attendance Kiosk to check-in.
- B. Students who are unexcused tardy more than 7 occasions for either class or school or who are absent for reasons that violate school rules will receive disciplinary punishment.
- C. Students tardy more than 7 occasions will enter a progressive disciplinary sanction:

1st Offense: Student will receive an after school detention on Tuesday or Thursday. The time of the detention is from 3:00 – 4:00 PM and the cost is \$10. No electronics are permitted and the student must either do school work or sit quietly. NO SLEEPING. This begins after the 7 school-provided free tardies are used up. The next tardy (number 8) will result in this disciplinary action. The school offers 7 free cumulative tardies to school each semester. (8 unexcused tardies.)

2nd Offense: Student will receive an after school detention on Tuesday or Thursday. The time of the detention is from 3:00 – 4:00 p.m. and the cost is \$20. (4 additional unexcused tardies - 12)

3rd Offense: Student is given a Saturday detention and a meeting is required between the parents and the Dean of Students' Office. (4 additional unexcused tardies – 16)

4th Offense: Student must serve a two day in school suspension, will be issued a Saturday detention, and a meeting is required between the parents and the Dean of Students' Office (4 additional unexcused tardies – 20.)

5th Offense: Student must go in front of a Disciplinary Review Hearing. (Any unexcused tardy over 24)

Notification provided to the parent(s) when a student is absent.

- A. Parents are informed of their son's absence and tardiness on the report card and through the Veracross parent portal. For clarification of any student attendance record, please consult the Attendance Office.
- B. Parents whose sons will be out of school for 3 or more days need to contact the guidance counselor and the Attendance Office.
- C. If a student will be absent for fewer than 3 days due to illness, the student should contact a fellow student and/or the teacher directly.
- D. If a student is absent for three or more days due to illness, the student must have a doctor's note detailing the situation.

Absence, Tardy and Early Dismissal as a result of Illness:

Illness is considered excused from school and the student should be permitted to make up any work they missed including quizzes, tests and exams.

- V. USE OF SCHOOL FACILITIES: The school buildings, the classrooms, the facilities, the furniture, and the surrounding properties are valuables that should be treated with respect. Defacing or damaging any of the above will result in severe disciplinary measures.

- A. Regulations: To insure the smooth operation of a school day, to avoid damage to school property and injury to a student, the following rules will be observed at all times:

1. Classrooms: Students must respect the materials in a classroom. Students are not to sit on window ledges or tamper with window blinds. Unless detained, or when permission is granted, and only under the supervision of or by a faculty member or the Attendance Office, students are expected to leave classrooms, computer labs, writing labs, and academic support at the end of a school day.
2. Gymnasium: Physical education classes, official team practices and supervised intramurals have first priority for gym use. At other times, students may use the gym when the school designates "open gym" time. Student use of the gym is never allowed unless there is adult supervision by a staff member.

PLEASE NOTE: Tennis or basketball shoes must be worn. Rubber-soled jogging shoes are not permitted on the gym floor.

3. Library: A schedule of library hours will be posted at the beginning of the school year. The library is to be used for research, reading and quiet study only. Students failing to abide by library regulations will lose the right to use the library.
4. School Offices: Students may go to the school offices such as the Main Office, Attendance Office, Counseling Center, Business Office and Athletic Office before and after school, or during free periods. During assigned class periods, written permission must be obtained from the classroom teacher.

5. Stairways and Corridors: Between assigned periods, the stairs nearest St. John DeMatha Hall are used for going up; the stairs nearest the old gym for going down. The east stairwell is for both directions; students should walk to the right of the stairwell.
6. Cafeteria: See Section II, Part B, numbers 3 and 4.
PLEASE NOTE: In order to prevent the disturbance of classes in session, students are not permitted to loiter or wander through the corridors or stairways during lunch or free period.
7. Locker Room: Students may use the locker room before and after physical education classes, official team practices, interscholastic games and supervised intramurals. Students playing on official school teams may use a lock on one locker during the season of the sport played. The lock is obtained from the Attendance Office at a nominal fee. The locker room or weight room is not to be used between classes or during homeroom and lunch periods without specific permission from the athletic department. Food and drink are prohibited in these areas at all times. Students may not be in locker room before or after school unless supervised by an adult
8. Lockers: Students are permitted to use only one locker. Only school locks are to be used. All students are issued a school lock at the orientation program held for new students on the first day of school. Thereafter, school locks may be obtained in the Attendance Office for a nominal fee. A student uses this lock until he leaves school or graduates. New lockers are assigned each year. On the final class day prior to the second semester examinations, each student is to empty his locker completely, leaving it clean and unlocked.
Lock combinations number should remain confidential, and students should insure that locks are properly fastened at all times. The school is not responsible for the items placed in a locker by the student.
Valuable items should not be stored in locker overnight. Students should plan their school day so as to avoid the need to open lockers while classes are in session.
9. Off Limit Areas:
The following areas are off limits to students:
 - a. The area between the school and the apartments.
 - b. The Antler Room entrance.
 - c. The areas outside the South side doors of the auxiliary gym.
10. Before and After School Hours:
 - a. Students who arrive to school prior to 7:30 a.m. must report to the cafeteria. The school opens at 7:00 a.m.
 - b. Students waiting for transportation must report to the assigned after-school waiting room. Students may not leave school grounds after 3:15 p.m. and return for transportation.
 - c. Students waiting for athletic practices must report to the assigned waiting areas.
 - d. Students who need to be on school grounds after 3:15 p.m. must report to their assigned area (waiting room, activity, SAT prep class, etc.). Students may not loiter in the parking lot, hallways, classrooms or other areas of the school after 3:15 p.m.

VI. PERSONAL APPEARANCE: Each student is responsible for his appearance. The school reserves the right to determine if a student meets appropriate standards of dress and grooming. Thus, certain guidelines and limitations are established by the Administration:

A. THE SCHOOL UNIFORM:

1. The official school uniform consists of a single-breasted blazer (maroon for seniors and juniors; navy blue for sophomores and freshmen) with school emblem sewn on the left pocket, khaki dress trouser with "DM" logo on the pocket, appropriate dress belt, solid colored dress shirt, tie, dress shoes and socks above the ankle. Dress pants are defined as pants that can hold a crease and are not of the "chino" style. Uniform pants may not be tailored to make skinny pants. No long sleeved undershirts are to be worn under short-sleeved shirts. Tattoos must be covered at all times by a long sleeved button up shirt only. Shirts that do not qualify include Hawaiian, flannel and shirts designed to be worn without a tie. Students may select from two styles of shoes carried by Potomac Clothing that can be ordered directly from the supplier/ Potomac Clothing. Aerobic shoes, other athletic-type shoes, and work-style shoes are not considered dress shoes and, therefore, may not be worn. As well, shoes must not extend above the ankle. No boots are allowed. (It is expected that the uniform will be purchased from Potomac Clothing 1201 Taft Street Rockville, Maryland 20850, www.DeMathaUniforms.com. Uniforms purchased elsewhere which do not conform will not be allowed.

PLEASE NOTE: Apparel such as head bands, hats, caps, top coats, jackets, denim shirts, corduroy pants, etc. are not part of the school uniform and may not be worn during school hours. If it is necessary because of extremely cold weather a student may wear a DeMatha sweater under his blazer.

Earrings, Band-Aids, rubber-bands and other ornamental accessories are not consistent with the school dress code and may not be worn. Students will be asked to remove the earring or be sent home. Furthermore, nail polish and visible tattoos are not allowed. Likewise, non-school sponsored buttons, and non-religious badges or buttons are not permitted to be worn. Students shall not write or draw on any parts of their uniform nor shall they alter their uniform in any way (writing on it, breaking down the backs of shoes, ripping pants or blazers, etc.).

The school uniform is worn at all times during school hours with the following exception: tag days. On tag days, students are restricted from wearing sandals/flip-flops, headwear, pajamas or clothing with inappropriate messages. Earrings, shorts and sweats are permissible. On the later occasion students may wear only a DeMatha sweater in place of the DeMatha blazer if it is being cleaned and with a receipt and permission from the Dean of Students. Senior privileges include striped and nonsolid colored dress shirts after the Christmas break or after negotiation with administration. At NO time can a student wear a jacket or hoodie during the school day throughout the school year. If a student is found to continuously wear inappropriate outerwear with his uniform, he may have his outerwear confiscated and returned at the end of the school day. When this violation is continuous the student may receive a Saturday Detention. Blazers must be worn at all times except during science labs, band rehearsals and practical art classes. Blazers may be removed during lunch periods while students are in the cafeteria. Students not wearing blazers at appropriate times will be considered out of uniform.

PLEASE NOTE: If a student reports to school out of uniform, he is required to call home and have his parent or guardian bring his uniform to school. A student who cannot comply with the uniform regulation may not attend classes and must go home. This will result in a Saturday detention being issued. In some instances a student may have the option to rent the uniform item for a small fee.

During the fall of each school year the Dean of Students Office will announce the date for changes from warm weather uniform to full uniform and in the spring they will announce the date for changes from the full uniform to the warm weather uniform. The warm weather uniform consists of DeMatha khaki trousers, belt, solid colored dress shirt (with full collar and buttons down the front) or a DeMatha issued golf shirt, dress shoes and socks. Ties and blazers are optional. Students may wear any DeMatha polo including the long sleeve DeMatha polo sold in the Stag Store. If a student feels that he needs additional layers, during the warm weather dress, then he may wear the DeMatha sweater over top (sold by Potomac Clothing) or the DeMatha fleece sold in the Stag Store. The only time a student may wear the DeMatha fleece as a uniform item is during the warm weather dress time frame. The DeMatha fleece may not be worn in place of the DeMatha blazer at any time.

Warm weather polos are purchased in the Stag Store and can be either Under Armor or other brands sold at the store. However, the only colors that can be used for uniform compliance are shades of red, white or blue. No other color polos will be permitted to be worn as a school uniform. The other colors can be purchased for private wear outside of school use.

Students must be in the appropriate uniform from 8:15 a.m. until 2:55 p.m.

B. GROOMING. The haircut/hairstyle and overall appearance of the student is expected to complement the school uniform and promote the school's traditional approach to secondary education. If a student arrives to school with an inappropriate hairstyle or facial hair, he will not be allowed to attend class until the appropriate changes are made.

Hair Style:

- Unacceptable hairstyles include dyed hair, Mohawk or Mohawk styles, lines or designs, extensions, hairbands, beads, clips, decorations, or hair ties (that are not black).
- Locs, braid and cornrows must be well kept, neatly groomed, attached to the scalp and may not have loose ends. Hair styles may not be individually wrapped which causes them to stand up by themselves.
- Hair may not extend below the eyes and may not be more than 2 inches below the collar line, unless it is braided and meets the braid standard.

Facial Hair:

- No facial hair permitted except neatly groomed mustaches.
- No “cutting” of eye brows (suspendable offense)
- Side burns must be flat and neatly trimmed and may not extend below the ear lobe.

Consequences:

- *Student with an illegal hairstyle or facial hair will be asked to fix it immediately which may include being sent home until it has been fixed in accordance with school policy.*
- *Repeated grooming violations could result in suspensions or eventual dismissal from school. Refusal to comply with the DeMatha grooming policy will result in an immediate Suspension from school.*
- *The Dean of Students and Administration will make final decision regarding grooming.*

VII. STUDENT VEHICLE AND PARKING LOT REGULATIONS:

Students wishing to use the school parking lots must obtain a parking permit from the Dean’s Office for a fee. If space is available and a permit is granted, the parking permit is to be displayed on the rear-view mirror. Seniors will use the lot on 43rd Avenue and may go to their cars during the school day. Juniors will use the Nusca parking lot on Madison Street and may not go to their cars during the school day. In addition, the following rules must be observed:

- A. All motor vehicles will be assigned a designated parking space that must be respected by the individual drivers. Violations will result in the students’ loss of parking lot privileges.
- B. For safety reasons and traffic flow, we suggest student be dropped off 1) in the “drop off zone” located on Madison Street in front of the Convocation Center, 2) in the two parking lots closest to Route 1 or 3) in the back parking lot off 43rd Avenue. The back parking lot lanes are one way, south to north. Enter the lot at the Antler Room end and leave the lot at the McCarthy Center end. Parking/waiting of any kind in the front circle or in any of the visitor parking spaces is prohibited. Students should not be dropped off in the faculty parking lot. Pedestrians always have the right away on campus.
- C. Parking spaces are reserved for those students who have received parking permits. Students who park on the lot illegally will receive a Saturday detention and may be towed per Parking Permit Application and Contract (see Appendix H). Students who continuously park illegally will face further disciplinary action. Likewise, those students who have permits will be disciplined for:
 1. Improperly displayed permits.
 2. Parking in a space other than the space assigned.
 3. Using two parking spaces.
 4. Litter in their parking space.
 5. Cars illegally parked may be booted until a \$20 fine is paid. Drivers of such cars will subsequently be banned from the lot.
- D. Students are to observe all traffic rules; namely
 1. No parking along fire lane (yellow curb)
 2. Speed Limit: 5 mph.
 3. Speeding away from the parking lot, and/or the screeching of wheels is a serious violation of school policy. At the first offense, the school will prohibit the student from use of the parking lot for two weeks; after the second offense, a month; the third will result in loss of the parking permit. In addition, parents will be notified and strongly urged to prohibit the student’s use of the car for the corresponding periods of time.
 4. Parking areas in front of the school are strictly off limits to student parking. Cars illegally parked on any of the school lots will be ticketed, fined and face possible towing at the owner’s expense.
- E. When not occupied, cars should be locked.
- F. The driver is responsible for litter around his car.
- G. Once a vehicle has been parked in the lot neither the driver nor any other student is allowed to drive away from that space until the driver is ready to leave for home.
- H. Loud playing of radios, tapes, CD’s, etc., will result in the loss of the student’s parking permit.
- I. Smoking in a car, whether by the driver or others occupying the car at the time, will subject all students in the car to the regular school punishment for smoking and can result in the loss of the parking permit.
- J. Students are not allowed to play any type of ball game or to use skateboards on the main school parking lot during school hours. Water balloons and squirt guns are not allowed on campus.

- K. Students who cannot obtain parking permits and must park on area streets are not allowed to go to and from their cars during the school day without permission.
- L. Juniors may not go to their car during the day without permission.

PLEASE NOTE: The school reserves the right to inspect a student's car when parked on DeMatha property.

VIII. GRADUATION DRESS REQUIREMENTS

Dress and grooming requirements for students on graduation day: Academic gown, cap with tassel. Required dress under gown is dress shirt with regular collar, tie (no bow ties), dress trousers, dress shoes, socks and no coat. Regular grooming required for school attendance is mandatory; clean shaven, proper hairstyle (dyed hair, designs, etc. are not allowed), no earrings. No gum chewing. No cell phone or electronic use. Students who fail to meet these standards may not be allowed to participate in the ceremony and/or will be assessed additional community service hours for each offense and may not pick up his diploma until completed.

IX. BEHAVIOR AT ATHLETIC EVENTS FOR ALL SPECTATORS

(Students, families, alumni and boosters.) In order to help assist in our safety of our students at school related functions, DeMatha reserves the right to administer an alcohol test to any student suspected of drinking prior to or during any DeMatha- related function. A student who is suspected of alcohol use or observed to act in a manner that resembles that of a student who is intoxicated or who smells from alcohol will be removed from the DeMatha event. At this time an attempt will be made to notify a parent that we are administering a Breathalyzer test to determine whether or not the student has been drinking. If a parent cannot be reached DeMatha will administer the alcohol breath test and hold the student, if necessary, until he can be picked up.

A. A SPECTATOR SHOULD:

1. Remember that his conduct reflects the good name of his school.
2. Be sportsmanlike at all times.
3. Control his temper.
4. Without comment, accept the decisions of the officials.
5. Treat officials, and an opposing school's players, coaches, cheerleaders and fans with respect, consideration and courtesy at the scene of the game or elsewhere; and at home games make them all welcome.
6. In victory, be gracious to the losers; in defeat, sportsmanlike.
7. Recognize and be willing to applaud the achievements and competitive spirit of opposing teams and players.

B. A SPECTATOR SHOULD NOT:

1. Use profane language or indecent gestures toward officials or opposing players, coaches, cheerleaders or fans.
2. Boo or ridicule anyone at any time
3. Enter the playing field or court during the contest.
4. Damage, deface, or litter the property of an opposing school while attending a game.
5. Bring noisemakers of any kind to a basketball game.
6. Display posters or signs that are offensive to others.
7. Possess, use or be under the influence of any drug or alcoholic beverage at any athletic event in which DeMatha participates.

ANY VIOLATION OF THE PRECEDING BEHAVIOR CODE WILL RESULT IN REMOVAL FROM THE EVENT AND DISCIPLINARY ACTION BY THE SCHOOL.

Because of our common values, our shared religious heritage, and our educational missions, the Catholic schools of the Greater Washington, Baltimore, D.C. metropolitan areas have agreed that any negative behavior at any school venue or event shall be reported to the student's home school where he or she will be accountable as if the behavior took place at the student's home school.



APPENDICES

APPENDIX A

DRUG AND ALCOHOL ABUSE

In keeping with the recommendation of the Board of Education of the Archdiocese of Washington that each school in the Archdiocese have and publish a policy statement concerning alcohol or other drug abuse, DeMatha Catholic High School hereby publishes the following statement of policy:

1. Recognizing the responsibility of the school toward both the individual student and the school community as a whole, two goals are seen as important with regard to any action taken in response to an incident involving the use of alcohol or other drugs.
 - a) The counseling and rehabilitation of the individual involved.
 - b) The protection of all students in the school.
2. Effective solutions to the substance problem must include all those charged with the care of the DeMatha community: the school administration, counselors, teachers, parents, students and when appropriate, law enforcement officials.
3. Students who wish to discuss a substance abuse problem are encouraged to speak with a counselor at any time. Such discussions are held strictly confidential unless otherwise indicated by law.
4. When evidence indicates that a student is in possession of or under the influence of alcohol or other drugs on the school property or at a school function on or off school property, the school must impose sanctions against the student. In addition, when it is known among the students and faculty that a student is a continual user of controlled substances outside the school environment, sanctions may have to be imposed. Depending on the circumstances, these may include notification of parents and civil authorities, required referral to an agency outside the school, suspension, expulsion or any other sanction deemed necessary by the school administration.
5. When evidence indicates that a student is involved in the sale or any other form of distribution of drugs or alcohol that student is subject to immediate expulsion. The school is responsible for notifying civil authorities in cases of drug distribution
6. DeMatha has the right to use K-9 Drug, Alcohol, Tobacco and Firearms dogs to search any student's bag, luggage, vehicle, locker or property. Students going on field trips should expect to have luggage checked.

APPENDIX B

SCHOOL REGULATIONS WITH RESPECT TO ACADEMIC DISHONESTY

A. SCHOOL POLICY

Academic dishonesty is a serious offense. It destroys the quality of scholarship in the school; it deprives each and every student of a just return on honest academic effort, and it damages the student's integrity and character.

In order to impress upon all students, the seriousness of academic dishonesty, the following penalties may be imposed when a student is found to have committed an act of academic dishonesty.

1st Offense:

- a) The student will receive an F (zero) grade for the assignment on which the act occurred.
- b) The incident will be reported to the Dean of Students' Office for official recording on the student's disciplinary record.
- c) Parents will be notified of the incident.
- d) The student will receive a Saturday detention.

2nd Offense: (occurring in any subject)

- a) Failing grade for the semester in the course in which the second offense of academic dishonesty has occurred.
- b) The student is suspended from school.
- c) The student is placed on probation; parents are notified.
- d) The incident is recorded on the student's record in the Dean of Students' Office.

3rd Offense: (occurring in any subject)

- a) The student may be expelled from school.
- b) A failing grade is received for the course in which the academic dishonesty took place.

The above penalties are to be assigned for any incident of academic dishonesty in any subject taken. A student's record of academic dishonesty will last for two calendar years or until the student leaves the school, if this should occur first.

B. PROCEDURES TO BE FOLLOWED IN ANY CASE OF ACADEMIC DISHONESTY

When a faculty member detects an incident of academic dishonesty, the incident is to be reported to the Dean of Student's Office.

1. The incident is to be recorded, and the student will be asked to read and to either agree or disagree with the description of the incident.
2. If a student disagrees with the description, a hearing will be held with the student, the teacher, the Dean of Students, and the department chair. At the request of the student, his counselor may attend the hearing, but will not take part in the rendering of any decision. The decision will be rendered by the Dean of Students. A student may appeal the decision, in which case the incident will be reviewed by the Assistant Principal and members of the Department Chairs Committee who were not in any way involved with the previous hearing. The decision made by the hearing committee will be final.

Note: Any student found guilty of Academic Dishonesty during the school year may not be eligible for participation in the Academic Awards Night.

C. EXAMPLES OF ACADEMIC DISHONESTY:

1. Intentionally using or attempting to use unauthorized materials, information or study aids in any academic exercise.
2. Intentionally or knowingly helping or attempting to help another to commit an act of academic dishonesty.
3. Intentionally or knowingly representing the words or ideas of another as one's own in any academic exercise
4. The altering of any previously returned graded academic work in order to obtain higher grade.
5. Submitting previously returned academic work (the student's or classmates) as new work in another subject.
6. The submitting of academic work done by another person as one's own work.
7. Plagiarism: presenting any work or part thereof that is not your own, as your own. This includes the academic work of other students.
8. Movement of the head or eyes during a test when forewarned by the teacher or faculty not to do so.
9. The copying of homework, lab reports or other exercises, even if not graded assignments.
10. Giving or receiving test or quiz information between classes.

APPENDIX C

PARENT PERMISSION FORM FOR FIELD TRIPS AND RELEASE OF LIABILITY (SAMPLE)

Dear Parent and Legal Guardian:

Your son is eligible to participate in a school-sponsored activity requiring transportation to a location away from the school building. **A FIELD TRIP INFORMATION SHEET** describing the activity and the arrangements is attached. I, and my son, knowingly appreciate and voluntarily undertake and assume the risks of the activity.

If you are requesting that your son participate in this activity, please complete, sign, and return the following statement of permission and release of liability. As parent or legal guardian, you remain fully responsible for any legal responsibility that may result from actions taken by the named student. Further, the student remains subject to all school rules and regulations during activities that take place away from school.

I hereby give permission for my son, _____, to participate in the activity described on the attached information sheet and I acknowledge receipt of the information sheet.

In consideration of the opportunity for my son to participate in this activity, **I HEREBY RELEASE** DeMatha Catholic High School, the Order of the Most Holy Trinity and of the Captives, and their respective directors, officers, employees and agents from any and all liability, claims, demands, actions and causes of action arising out of or related to any loss, damage or injury that may be sustained by my son.

(Print Parent's/Guardian's Name)

(Date)

Please return this form to _____

By: _____

(Parent's/Guardian's Signature)

**APPENDIX C
CONTINUED**

**DeMATHA CATHOLIC HIGH SCHOOL
FIELD TRIP INFORMATION SHEET
(SAMPLE)**

Description & Purpose of Activity: _____

Destination: _____

Designated School Moderator of Activity: _____

Chaperone(s): _____

Date, Place & Time of Departure: _____

Date, Place & Anticipated Time of Return: _____

Method of Transportation: _____

Student Cost: _____

Meals: _____

Clothing/Dress Code: _____

Other Information: _____

APPENDIX D

STATEMENT CONCERNING THE REPORTING OF CHILD ABUSE AND NEGLECT

What Must Be Reported?

Any instance of known or suspected child abuse must be reported to the civil authorities and to the authorities within the Archdiocese of Washington.

Who Must Make a Report?

Any person who has reason to believe that a child has been abused under any circumstances is required by law to make a report to Civil Authorities. The individual making a report of such instance(s) need not furnish proof or make an investigation or otherwise determine that the alleged abuse actually occurred. Investigation is a function of the law enforcement authorities and any attempt by the individual making the report to probe into specific facts and circumstances may serve to hinder or interfere with a proper investigation.

The State of Maryland, the District of Columbia and the State of Virginia grant legal immunity from civil or criminal liability to any person, institution or hospital making a report in good faith and/or participating in judicial proceedings or investigations concerning such reports. Reports are received in confidence by the authorities.

For purposes of clarity the following definitions of sexual abuse, child abuse, and child neglect are provided:

Sexual Abuse: Any act which involves sexual molestation or sexual exploitation of a child by a parent or any other person who has permanent or temporary care or custody or responsibility for supervision of a child, whether physical injuries are sustained or not. Sexual abuse includes acts of incest, rape or sexual offense in any degree, sodomy and unnatural or perverted sexual practices, lewd or indecent acts or proposals, permitting or encouraging a child to participate in acts of prostitution or pornography.

Physical Abuse: Sustaining of a physical injury by a child as a result of cruel or inhumane treatment or as a result of a malicious act under circumstances that indicate a child's health or welfare is harmed or threatened thereby.

Child Neglect: Abandonment of a child by a parent, custodian or guardian; lack of care or control in respect to subsistence, education or physical or emotional health (excluding instances of financial inability to so provide); refusal or inability to discharge parental or custodial obligations and expression of intention by a parent, guardian, custodian or institution to discontinue care.

If you suspect that abuse has occurred or have any questions about reporting child abuse, immediately notify any of the following: President, Principal, Assistant Principal, Director of Guidance or Dean of Students.

APPENDIX E

DeMATHA CATHOLIC HIGH SCHOOL STUDENT TECHNOLOGY AGREEMENT

2023-2024

DeMatha Catholic High School uses technology to increase collaboration, deliver modern lessons, and promote student engagement. The school collaborates with Google and Veracross for communication and classroom management. Parents and students should be fully aware of the entire Technology Agreement prior to the first day of classes. The Technology Agreement includes four parts.

Resources defines the types of tools available at DeMatha and their role within academic life.

Acceptable Use Policy explains the student's responsibilities while using those resources.

Device Use Policy explains the rules regarding bringing personal devices to school and borrowing school Chromebooks.

Social Media Policy describes how social media may be used while enrolled at DeMatha.

Acceptance of this agreement is completed during Online Enrollment & Re-Enrollment. All violations of this policy will follow the discipline procedures outlined in the Student Handbook. Violations may result in loss of computer use, fees, disciplinary action including dismissal, and/or appropriate legal action.

Resources

School resources include, but are not limited to laptops, desktops, tablet devices, Internet access, network folders, e-mail addresses, projectors, printers, and all infrastructure related equipment. Use of Google Apps is governed by this policy in addition to Google policies. For students without computer access at home, you may obtain a loaner Chromebook through the technology center. Parents must complete a separate electronic form before any device will be issued.

Student ID and ID Cards: The Veracross Person ID is unique for each student. This number is the Student ID and found on schedules and report cards. Student ID Cards are provided to students as part of the beginning of school orientation. Students may not share ID cards for any reason. Replacement cards are available for a fee of \$10 in the Technology Center. Your Student ID Card is used for attendance, building access, cafeteria payments, student identification, and printing. For the purpose of cafeteria payments, a separate ID number is sent by email to parents on August 1, which is required for registration in that program. Students are expected to bring their Student ID to school every day and must present their ID upon request by any faculty or staff member. For student safety, ID cards should be worn on a lanyard and must be visible at all times.

DeMatha User Accounts: All students are issued a single student account that is used for accessing Veracross, DeMatha Gmail/Google Apps and the student wireless network while enrolled at DeMatha. This information is sent by email to new parents. Students enrolling late will receive their credentials through their guidance counselor. Upon graduation or voluntary withdrawal, students will be provided no more than **30 days** to obtain all of their data before all account access is removed. Personal email accounts are not allowed for school communication.

In general, usernames contain the student's legal first name, followed by a period(.), then the student's last name, and finally the two-digit year of graduation. When logging into Veracross or Google, students **MUST** include their full email address. For example, John Smith Class of 2027 has a username of john.smith27@student.dematha.org. Account sharing is prohibited and passwords should be difficult to guess to protect your account from unauthorized access.

Multi-factor Authentication: MFA is enforced for all student accounts. DeMatha has selected Okta as the service provider. This mechanism requires an additional level of proof of account ownership in the form of one-time codes, etc. to secure access to Email and Veracross. Instructions for setting up these policies are provided by email as part of orientation.

Acceptable Use Policy (AUP)

The use of technology, whether owned by DeMatha or the student, involves responsibility. Use of the school networks is a privilege, not a right. Failure to comply with school policy may result in temporary or permanent loss of access and possible disciplinary or legal action. Students will be held accountable for all activities that occur with their account and/or personal devices.

The following expectations apply for all technology at DeMatha:

- Students will not access or post inappropriate materials including, but not limited to sites containing sexual content, obscene content, threatening material, profanity, illegal activities, hacking/proxy avoidance systems, commercial activities, or virus/spyware content.
- DeMatha has content filtering policies applied to all Internet connections. Students will not attempt to circumvent the filter or deliberately attempt to access resources to which the user is not authorized. Students additionally may not install or alter any system hardware or software on DeMatha-owned equipment without direct supervision from the technology department staff. Reading or modifying other student files in any way is not permitted.
- Only files for DeMatha coursework may be saved to a student's Google Drive. Any file loss due to saving to 'My Documents' (local disk) will not be recoverable.
- Recording of audio, images, or video for any reason without express permission from both a staff member and the individuals being recorded is prohibited.
- Students understand that printing at school from personal devices may not be possible. Students can save their work to Google Drive and print using school machines.
- Personal devices used while at school are the responsibility of the owner. DeMatha is not liable for any device that is stolen or damaged on campus. The school reserves the right to monitor, review, and restrict the use of any device. The contents of the equipment are subject to review at any time, for any lawful reason, consistent with the policies of the Student Handbook and applicable law.
- Devices must be capable of running off a battery during the school day. Students should not expect teachers to make outlets available for charging during class and no student should disconnect other equipment to gain access to a power outlet. Additional batteries are recommended for devices that are not capable of running for an entire school day.
- Failures of DeMatha-owned equipment should be reported immediately to a staff member.

Device Use Policy

All students are permitted to bring phones, laptops, and/or tablets to school. Use of these devices in common areas is governed by the Dean of Students. Subject teachers may have their own policy during class time. Cell phones are not recommended for completing classwork. The screen size and other limitations make them less than suitable for this purpose. All devices must be capable of connecting to wireless networks implemented with WPA2-Enterprise security. DeMatha does not endorse the use of any specific vendor and parents/students should use their own judgment in determining the device that best fits their usage and budget. Students who have technical issues with their own technology tool need to take care of this issue on their own. The school does not troubleshoot issues with personal devices.

Social Media Policy

Social media is as any form of online publication or presence that allows interactive communication, including, but not limited to current and future social networks, social and texting apps, blogs, forums and wikis. Examples include Facebook, Twitter, Instagram, Snapchat, YouTube, and Google. The school maintains the right to prevent the use of any social media platform on the school's network. DeMatha Catholic High School promotes the responsible use of social media for the purpose of building relationships, offering support, creative learning, and motivating others toward the good. When you use social media for academic purposes, such as for a school assignment, treat the platform as an extension to the classroom.

A DeMatha student is responsible for his actions, in person and Online. You represent the school 24/7. Student 'posts' are difficult to take-back and can have major impacts on future endeavors. Your teachers and future employers can view posts. Once you have posted information on the Internet, you have relinquished any claim to privacy. Use available security settings and be cautious in posting too much information about your physical location.

All forms of bullying are taken seriously. This behavior is not acceptable and will be reported immediately to the Dean of Students. Cyberbullying includes sending, posting, or sharing negative, harmful, false, or mean content about someone else. It can include sharing personal or private information about someone else causing embarrassment or humiliation. Liking or re-tweeting derogatory or malicious content will also be grounds for referral to the Dean of Students.

Students may not create any social media accounts that use the DeMatha Catholic High School name or logo without the express written authorization of the President.



APPENDIX F

NATIONAL COLLEGIATE ATHLETIC ASSOCIATION (NCAA)

DIVISION I ACADEMIC REQUIREMENTS

To study and compete at a Division I school, you must earn 16 NCAA-approved core-course credits, earn a minimum 2.3 core-course GPA and submit your final transcript with proof of graduation to the Eligibility Center.

CORE-COURSE REQUIREMENTS

Earn 16 NCAA-approved core-course credits in the following areas:

ENGLISH	MATH (Algebra I or higher)	SCIENCE (Including one year of lab, if offered)	ADDITIONAL (English, math or science)	SOCIAL SCIENCE	ADDITIONAL COURSES (any area listed to the left; world language or non-denominational religion/philosophy)
4 years	3 years	2 years	1 year	2 years	4 years

For Division I, 10 of your 16 NCAA-approved core-course credits must be completed before the start of your seventh semester, including seven in English, math or science.

QUALIFIER

As a Division I qualifier, you may practice, compete and receive an athletics scholarship during your first year of full-time enrollment at an NCAA Division I school.

- » Earn 16 NCAA-approved core-course credits in the right areas.
 - Complete 10 of your 16 NCAA-approved core-course credits, including seven in English, math or science, before the start of the seventh semester.
 - Complete your 16 NCAA-approved core-course credits in eight academic semesters or four consecutive academic years from the start of ninth grade.
- » Earn a minimum 2.3 core-course GPA.
- » Submit your final transcript with proof of graduation to the Eligibility Center.

ACADEMIC REDSHIRT

As a Division I academic redshirt, you may practice during your first regular academic term and receive an athletics scholarship during your first year of full-time enrollment but may NOT compete during your first year of enrollment. You must pass either eight quarter or nine semester hours to practice in the next term.

- » Earn 16 NCAA-approved core-course credits in the right areas.
- » Earn a minimum 2.0 core-course GPA.
- » Submit your final transcript with proof of graduation to the Eligibility Center.

* More information regarding the impact of COVID-19 can be found at en.ncaa.com/COVID19_Spring2023.



ELIGIBILITY CENTER

TEST SCORES

In January 2023, NCAA Divisions I and II adopted legislation to remove standardized test scores from initial-eligibility requirements. Check with the NCAA school you plan to attend regarding whether standardized test scores are necessary for admission or scholarship requirements.

** More information regarding the impact of COVID-19 can be found at on.ncaa.com/COVID19_Spring2023.*

CORE-COURSE LIST

Find your high school's list of NCAA-approved core courses at eligibilitycenter.org/courselist. No core-course list means courses taken from that high school will not count for NCAA eligibility. If your high school does not have a list, you risk being ineligible to play in college.

NONTRADITIONAL AND ONLINE COURSES

Nontraditional courses are taught online or through distance learning, hybrid/blended, independent study, individualized instruction, correspondence or similar means.

These types of courses may be acceptable for use in the NCAA eligibility certification process; however, it is important to make sure the nontraditional program has been approved and appears on your school/program's list of NCAA-approved core courses.

BE AHEAD OF THE GAME

- » Plan to register with the NCAA Eligibility Center at eligibilitycenter.org before your freshman year of high school. Visit on.ncaa.com/RegChecklist to help guide you through the registration process.
- » After six semesters of high school, ask your high school counselor from each school you have attended to upload an official transcript to your Eligibility Center account.

ADDITIONAL RESOURCES

- » [DII Academic Requirements flyer.](#)
- » [DIII Amateurism flyer.](#)
- » [International Initial-Eligibility flyer.](#)



Want more information? Visit
ncaa.org/playcollegesports.

CONTACT THE NCAA ELIGIBILITY CENTER

U.S. and Canada (except Quebec): 877-262-1492
Monday-Friday, 9 a.m. to 5 p.m. Eastern time

[@ncaaec](https://twitter.com/ncaaec) [@playcollegesports](https://www.instagram.com/playcollegesports) [@ncaaec](https://www.facebook.com/ncaaec)



ELIGIBILITY CENTER

NCAA is a trademark of the National Collegiate Athletic Association. January 2023.

DIVISION II ACADEMIC REQUIREMENTS

To study and compete at a Division II school, you must earn 16 NCAA-approved core-course credits, earn a minimum 2.2 core-course GPA and submit your final transcript with proof of graduation to the Eligibility Center.

CORE-COURSE REQUIREMENTS

Earn 16 NCAA-approved core-course credits in the following areas:

ENGLISH	MATH (Algebra I or higher)	SCIENCE (Including one year of lab (if credit))	ADDITIONAL (English, math or science)	SOCIAL SCIENCE	ADDITIONAL COURSES (Any area listed to the left, world language or nontraditional religion/philosophy)
3 years	2 years	2 years	3 years	2 years	4 years

QUALIFIER

As a Division II qualifier, you may practice, compete and receive an athletics scholarship during your first year of full-time enrollment at an NCAA Division II school.

- » Earn 16 NCAA-approved core-course credits in the right areas.
- » Earn a minimum 2.2 core-course GPA.
- » Submit your final transcript with proof of graduation to the Eligibility Center.

PARTIAL QUALIFIER

If you have not met all of the Division II academic standards, you will be deemed a partial qualifier. As a partial qualifier, you may practice and receive an athletics scholarship, but may NOT compete, during your first year of full-time enrollment at an NCAA Division II school.

* More information regarding the impact of COVID-19 can be found at on.ncaa.com/COVID19_Spring2023.



NCAA DIVISION II

MAKE IT YOURS.

NCAA ELIGIBILITY CENTER

TEST SCORES

In January 2023, NCAA Divisions I and II adopted legislation to remove standardized test scores from initial-eligibility requirements. Check with the NCAA school you plan to attend regarding whether standardized test scores are necessary for admission or scholarship requirements.

**More information regarding the impact of COVID-19 can be found at on.ncaa.com/COVID19_Spring2023.*

CORE-COURSE LIST

Find your high school's list of NCAA-approved core courses at eligibilitycenter.org/courselist. No core-course list means courses taken from that high school will not count for NCAA eligibility. If your high school does not have a list, you risk being ineligible to play in college.

NONTRADITIONAL AND ONLINE COURSES

Nontraditional courses are taught online or through distance learning, hybrid/blended, independent study, individualized instruction, correspondence or similar means.

These types of courses may be acceptable for use in the NCAA initial-eligibility certification process; however, it is important to make sure the nontraditional program has been approved and appears on your school/program's list of NCAA-approved core courses.

BE AHEAD OF THE GAME

- » Plan to register with the NCAA Eligibility Center at eligibilitycenter.org before your freshman year of high school. Visit on.ncaa.com/RegChecklist to help guide you through the registration process.
- » After six semesters of high school, ask your high school counselor from each school you have attended to upload an official transcript to your Eligibility Center account.
- » For more information on Division II, visit ncaa.org/D2.

ADDITIONAL RESOURCES

- » DI Academic Requirements flyer.
- » DIII Amateurism flyer.
- » International Initial-Eligibility flyer.



Want more information? Visit
ncaa.org/playcollegesports.

CONTACT THE NCAA ELIGIBILITY CENTER

U.S. and Canada (except Quebec): 877-262-1492
Monday-Friday, 9 a.m. to 5 p.m. Eastern time

[@ncaaec](https://twitter.com/ncaaec) [@playcollegesports](https://www.instagram.com/playcollegesports) [@ncaaec](https://www.facebook.com/ncaaec)



ELIGIBILITY CENTER

NCAA is a trademark of the National Collegiate Athletic Association. January 2023.

APPENDIX G

(SAMPLE TRANSCRIPT)



DeMatha Catholic High School
 4313 Madison Street, Hyattsville, Maryland 20781
 The Trinitarian Fathers and Brothers
 Phone: 240.764.2290 | Fax: 240.764.2275
 Private School Approved by Maryland State Department of Education
 Accredited by the Middle States Association of Colleges and Schools



Name of Pupil:
 Student ID:
 Address:

Date Enrolled:

Date of Birth:

Phone:
 Parents / Guardian:
 Previous School:

Credits Earned: 17.5

Graduation Date:

Grade Level 9			
#	Course Description	Grade	GP / CR
1113	Honors English 9	A	4.5 / 1.0
5525	Honors Latin 3	A	4.5 / 1.0
3643	Honors Algebra 2	A	4.5 / 1.0
7626	Sinfonia	A	4.5 / 1.0
0001	The DeMatha Way	A	4.0 / 0.5
4243	Honors Biology	A	4.5 / 1.0
9123	Health	A	4.0 / 0.5
0123	The Search for God	A	4.0 / 1.0
		Credits Attempted:	7.0
		Credits Earned:	7.0
2015-2016 Summary		Career Summary	
GPA:	4.36	GPA:	4.36
Days Absent:	0.0	Credits Attempted:	7.0
Days Tardy:	0.0	Credits Earned:	7.0

Grade Level 10			
#	Course Description	Grade	GP / CR
1243	Honors American Literature	A	4.5 / 1.0
5553	AP Latin 4	A	5.0 / 1.0
3574	Honors Geometry	A	4.5 / 0.5
3575	Honors Trigonometry	A	4.5 / 0.5
7626	Sinfonia	A	4.5 / 1.0
4543	Honors Chemistry	A	4.5 / 1.0
2113	Honors World History	A	4.5 / 1.0
0223	The Living Word	A	4.0 / 1.0
		Credits Attempted:	7.0
		Credits Earned:	7.0
2016-2017 Summary		Career Summary	
GPA:	4.50	GPA:	4.43
Days Absent:	0.0	Credits Attempted:	14.0
Days Tardy:	1.0	Credits Earned:	14.0

Grade Level 11			
#	Course Description	Grade	GP / CR
1354	AP Language & Composition	A	5.0 / 0.5
3743	Honors Pre-Calculus	A	4.5 / 0.5
7626	Sinfonia	A	4.5 / 0.5
4663	AP Environmental Science	A	5.0 / 0.5
4623	Foundations in Engineering	A	4.0 / 0.5
2554	AP US History	A-	4.5 / 0.5
0323	Christian Ethics	A	4.0 / 0.5
		Credits Attempted:	3.5
		Credits Earned:	3.5
2017-2018 Summary		Career Summary	
GPA:	4.50	GPA:	4.44
Days Absent:	0.0	Credits Attempted:	17.5
Days Tardy:	0.0	Credits Earned:	17.5

Grading System:

3.0 and over- Honors	A	A-	B	B-	C	D	F
3.5 and over- Dean's List	(94-100)	(90-93)	(84-89)	(80-83)	(74-79)	(65-69)	(below 65)
3.8 and over- Principal's List	Regular Courses	4.0	3.5	3.0	2.5	2.0	1.5
College Recommending Mark: C	Honors Courses	4.5	4.0	3.5	3.0	2.5	2.0
	AP or College Level Courses	5.0	4.5	4.0	3.5	3.0	2.5

Name of Pupil:

Transferred To:

Transfer Date:

Graduation Date:

APPENDIX H

DeMATHA CATHOLIC HIGH SCHOOL (SAMPLE - PARKING PERMIT)

Complete and sign all the information below. The cost for parking is \$100.

RULES AND REGULATIONS:

1. You are responsible for your parking space and any trash that is in it at all times. This includes the end of the school day.
2. You must park in your assigned spot only, with your parking permit properly displayed from your rear view mirror. If you lose your permit you must get a temporary parking tag from the Dean of Students.
3. You may not move or change your spot without notifying the Dean of Students.
4. Large gatherings or hanging out with loud music are not permitted at any time.
5. Misuse of your vehicle horn or alarm will result in a Detention and possible loss of your parking spot.
6. Underclassmen are not permitted in the parking lot.
7. No ball playing (simulated ball playing, tape balls or anything that resembles ball playing), including 4 square, hacky sack, Frisbees, throwing footballs, or any type of ball, or any type of disruptive behavior is permitted. This will result in loss of your item, which will get donated to a charitable organization.
8. Speeding, spinning of tires or any improper use of a motor vehicle results in an automatic loss of parking privileges and detentions will be issued.
9. Once the school day starts no student may cross over 40th Avenue to go to their car without the permission of a faculty or staff member.

Failure to abide by these rules or rules outlined in the Student Handbook will result in loss of parking privileges, towing of your vehicle (at your expense), detention or possible expulsion.

FILL OUT COMPLETELY

Student Name: _____

Student Grade for School Year 2023-2024: _____

Home Phone: _____

Parent Work Number: _____

Parent Name: _____

Vehicle Make: _____

Year: _____

Model: _____

Color: _____

License Plate #: _____

Circle One: MD/ VA/ DC/ Other

I understand and agree to abide by these regulations as well as all the regulations outlined in the Student Handbook. Additionally, as parent, I support the school rules and regulations and understand the policies pertaining to parking at DeMatha Catholic High School.

Student Signature: _____

Parent Signature: _____

Space Assigned: _____

APPENDIX I

RESEARCH DATABASES

FOR USE BY

DeMATHA STUDENTS, FACULTY AND STAFF ONLY

ProQuest Databases

REMOTE ACCESS: Available via the DeMatha Library homepage

Username: dmstags

Pswd: 4313stags#

SELECT DATABASES INCLUDE:

Literature Online (LION) -- LION contains 350,000+ works of English and American poetry, drama and prose; 136 full-text literature journals; and other key criticism and reference sources. An indispensable resource for undergraduate students, graduate students and faculty.

SIRS Knowledge Source -- A comprehensive portal offering centralized access to all SIRS products which target the needs of students with best-of content selected to support research, study, and homework in key curricular subjects.

SIRS Decades -- Features 5,000+ hand-selected primary and secondary source articles that highlight key events, movement, people, and places in 20th-century America.

Biological Science Database[®] (1946 - current) -- A full-text database supported by a specialized A&I file. Covers comprehensive scholarly output, managed by an expert editorial team overseeing content selection and indexing supported by a controlled vocabulary.

Coronavirus Research Database --

A free health and medical research database for openly available content related to the COVID-19 outbreak.

Agricultural & Environmental Science Database[®] (1960 - current) -- A full-text database supported by a specialized A&I file. Covers comprehensive scholarly output, managed by an expert editorial team overseeing content selection and indexing supported by a controlled vocabulary.

ProQuest Historical Newspapers: The New York Times[®] (1851 - 2013).

Major US Daily Newspapers:

Chicago Tribune

Los Angeles Times

New York Times

The Wall Street Journal

The Washington Post

EBSCOHOST DATABASES

REMOTE ACCESS: Available via the DeMatha Library homepage

Contact library for links and login information

SELECT DATABASE INCLUDES:

Academic Search Premier -- This multi-disciplinary database provides full text for more than 4,600 journals, including full text for nearly 3,900 peer-reviewed titles.

APPENDIX J

FAMILY EDUCATIONAL RIGHTS AND PRIVACY ACT

DeMatha Catholic High School (“DeMatha” or the “School”) complies with the Family Educational Rights and Privacy Act (FERPA), which is a Federal law that protects the privacy of student education records. In general, FERPA gives parents certain rights with respect to education records. (The rights granted to parents under FERPA automatically pass to the student when the student turns 18 or enrolls in college.) These rights and the related procedures of DeMatha are as follows:

- Parents have the right to inspect and review the student’s education records maintained by the School. Parents should submit to the Administrative Assistant to the Principal, a written request that identifies the record(s) they wish to inspect. The School will make arrangements for access and notify the parent of the time and place where the records may be inspected.
- Parents have the right to request that the School correct records they believe are inaccurate, misleading, or otherwise in violation of the student’s privacy rights. Parents who wish to request an amendment of the student’s records should write to the Administrative Assistant to the Principal, and clearly identify the part of the record they believe is inaccurate or misleading and the information they believe should be included in a corrected record. If the School decides not to amend the record as requested, the School will notify the parent of the decision and the parent’s right to request a hearing.
- Parents generally have the right to consent in writing to disclosures of information from a student’s education record. However, there are certain exceptions to the consent requirement, including disclosures under the following conditions:
 - To School officials who have a legitimate educational interest in the information. A school official is a person employed by the School as an administrator, supervisor, instructor, or support staff member (including health or medical staff); a person or company with whom the School has contracted to provide a service (e.g., attorney); or a parent or student serving on an official committee, such as a disciplinary or grievance committee, or assisting another school official in performing his/her tasks. A school official has a legitimate educational interest if the official needs to review an education record in order to fulfill his/her professional responsibilities or duties to the School.
 - To other schools to which a student is transferring.
 - In connection with financial aid under certain circumstances.
 - To specified officials for audit or evaluation purposes.
 - To organizations conducting certain studies for or on behalf of the school.
 - To accrediting organizations.
 - In order to comply with a judicial order or lawfully issued subpoena.
 - To appropriate officials in cases of health and safety emergencies.

The School also may disclose appropriately designated “directory information” without written consent unless a parent objects in writing. The primary purpose of directory information is to allow the School to include this type of information in certain publications. Examples of such publications include a playbill, showing the student’s role in a drama production; the annual yearbook; honor roll or other recognition lists; graduation programs; and sports activity sheets.

The School has designated the following as directory information [*Note: DeMatha may delete items from this list or add items that would not be considered harmful or an invasion of privacy if disclosed.*]:

- Student's name
- Participation in officially recognized activities and sports
- Address
- Telephone listing
- Weight and height of members of athletic teams
- Electronic mail address
- Photograph
- Honors and awards received
- Date and place of birth
- Dates of attendance
- Grade level

Parents who do not want the School to disclose the above directory information without their prior written consent must notify the Administrative Assistant to the Principal in writing by August 15, 2023.

- Parents have the right to file a complaint with the U.S. Department of Education concerning alleged failures by DeMatha to comply with the requirements of FERPA. The name and address of the Office that administers FERPA are: Family Policy Compliance Office, U.S. Department of Education, 400 Maryland Avenue, SW, Washington, DC 20202-8520.



APPENDIX K

SAFETY PLANS AT DeMATHA CATHOLIC HIGH SCHOOL

The safety of our students, faculty and staff continue to be a major interest for the governing Boards of DeMatha and the school Administration. Throughout the years DeMatha has conducted drills for all emergencies, and we are well-prepared. To this date, we have been blessed that our safety has not been compromised, but we must continue to be vigilant to safeguard all who are on our campus daily.

Guidelines are included here to describe actions that will be taken by school personnel for a particular emergency. Since no situation is identical in different settings, there may be on-the-spot alterations of the plan by faculty and staff for the protection of life. We ask students and parents to be familiar with the procedures and plans should an actual emergency occur on campus.

PARENT RESPONSE TO EMERGENCY SITUATION AT DeMATHA

- Parents are not to come to school.
- Parents must wait for notification from school and school officials for pick up directions.
- Pick up locations will be designated by emergency and police personnel. (St. Jerome Academy, 5207 42nd Place, Hyattsville; or any location designed by emergency personnel.)
- Parents are advised not to call the school.
- Bring photo ID to the student unification spot.
- Students will only be released to parents or guardians who have presented acceptable identification and are named on the school emergency form.

HOW TO RESPOND WHEN AN ACTIVE SHOOTER IS IN YOUR VICINITY

Quickly determine the most reasonable way to protect your own life. Remember that students are likely to follow the lead of faculty and staff during an active shooter situation. Call 911.

1. Evacuate

If there is an accessible escape path, attempt to evacuate the premises. Be sure to:

- Have an escape route and plan in mind
- Evacuate regardless of whether others agree to follow
- Leave your belongings behind
- Help others escape, if possible
- Prevent individuals from entering an area where the active shooter may be
- Keep your hands visible
- Follow the instructions of any police officers
- Do not attempt to move wounded people
- Call 911 when you are safe

2. Hide out

If evacuation is not possible, find a place to hide where the active shooter is less likely to find you.

Your hiding place should:

- Be out of the active shooter's view
- Provide protection if shots are fired in your direction (i.e., an office with a closed and locked door)
- Not trap you or restrict your options for movement

To prevent an active shooter from entering your hiding place:

- Lock the door
- Blockade the door with heavy furniture
- Black out windows

If the active shooter is nearby:

- Lock the door
- Silence your cell phone and/or pager
- Turn off any source of noise (i.e., radios, televisions)
- Hide behind large items (i.e., cabinets, desks)
- Remain quiet

If evacuation and hiding out are not possible:

- Remain calm
- Dial 911, if possible, to alert police to the active shooter's location
- If you cannot speak, leave the line open and allow the dispatcher to listen

3. Take action against the active shooter

As a last resort, and only when your life is in imminent danger, attempt to disrupt and/or incapacitate the active shooter by:

- Acting as aggressively as possible against him/her
- Throwing items and improvising weapons
- Yelling
- Committing to your actions

Reference: U.S. Department of Homeland Security

FIRE

In the event that a fire, smoke from a fire, or a gas odor has been detected:

- DeMatha will announce the emergency and pull the fire alarm (unless there is a gas smell – announce over intercom/PA system).
- Evacuate students and staff to a safe distance outside of the building.
- Follow the normal fire drill routine. If normal route(s) are too dangerous, follow alternate route.
- Teachers should take a class roster and account for all students. Roll must be taken after evacuation. (When possible and when it applies.)
- Principal or designee calls 911, notifies authorities,
- After consulting with emergency personnel the principal or designee may move students and staff to a primary relocation center (to be determined by Emergency personnel).
- No one should re-enter the building(s) until declared safe by fire service personnel.
- Principal or designee notifies students and staff of termination of emergency and resumption of normal operations.
- Principal or designee send parent alert.

EVACUATION / RELOCATION

- Call 911, if necessary.
- Principal or designee determines evacuation action.
- Consult emergency personnel.
- Principal or designee determines if students and staff should be evacuated outside of school buildings(s) or to relocation centers.
- Principal or designee notifies relocation center, sends parent alert.
- Direct students and staff to follow fire drill procedures and route. Do not sound fire alarm. If normal route is too dangerous, follow alternate route.
- Close all windows; turn off lights, electrical equipment, gas, water faucets, air conditioning, heating, and ventilation, if possible.

TEACHERS:

- Direct students to follow normal fire drill procedures unless principal or designee alters route or normal route is too dangerous.
- Take class roster.
- Close classroom doors and turn out lights.
- When outside building, account for all students. Inform principal or designee immediately if students are missing.
- If students are evacuated to a relocation center, stay with your class. Take roll again when you arrive at the relocation center.

EARTHQUAKE

DURING AN EARTHQUAKE:

- Stay calm.
- Shelter in place until further instructions.
- Take cover. If indoors, do a “drop and cover” under a desk, table, or bench, or stand alongside an inside wall, in an archway, doorway that does not have a door, or corner. Avoid windows, doorways with a door, bookcases, hanging fixtures, or outside walls until the shaking stops.
- If no protection is available, drop to the floor and cover your head with your hands. Make sure students are in “drop and cover” positions.
- Do not be surprised if the electricity goes out, or if fire alarms and sprinklers go on.
- Notify safety personnel of any injuries.

AFTER AN EARTHQUAKE:

- Keep students safe and relaxed. Carefully evaluate the situation.
- Use caution when moving students and staff to safe area(s).
- Make sure everyone is alright. Take class rosters and account for all students.
- Do not move the seriously injured unless they are still in danger. Administer first aid, if necessary.
- Check natural gas, water, and electrical lines for damage.
- Do not use the telephone, light switches, matches, candles, or other open flame unless you are absolutely certain there is not natural gas leaking.
- Do not touch electrical power lines or broken electrical equipment.
- Be prepared for aftershocks.

INTRUDER / HOSTAGE

INTRUDER: “AN UNAUTHORIZED PERSON WHO ENTERS SCHOOL PROPERTY.”

- Notify principal or designee.
- Ask another staff member to accompany you before approaching the intruder.
- Politely greet intruder and identify yourself.
- Ask the intruder the purpose of his/her visit.
- Inform intruder that all visitors must register at the main office.
- If purpose is not legitimate, ask intruder to leave.
- Accompany intruder to the exit.

IF INTRUDER REFUSES TO LEAVE:

- Warn of the consequences for staying on school property. Inform intruder that police will be called.
- Notify security or police and principal or designee if intruder refuses to leave. Provide full description of intruder.
- Walk away from intruder if he/she indicates potential for violence (be aware of actions, location, weapons, or packages, etc.)
- Principal or designee prepare for lockdown or activate “Code Red” lockdown.

HOSTAGE SITUATION:

- Call 911 immediately. Provide details of situation, ask for assistance.
- Notify principal or designee.
- Seal off area near hostage scene.
- Evacuate away from the situation.
- Give control of scene to police and hostage negotiation team.
- Keep detailed notes of events and actions.
- Keep parents notified via parent alert system/email.
- Parents are not to come to school until notified.

SEVERE STORM

SEVERE WIND, SNOW, RAIN, HAIL, THUNDERSTORMS, TORNADOES, HURRICANES & FLASH FLOODS

- Be alert for weather warnings. Monitor Emergency Alert Stations (NOAA Weather Stations, National Weather Service, local news agencies)
- Bring all students and staff inside building(s). Move to safe areas. Review “drop and cover”.
- Close windows and blinds; avoid outside walls.
- Take class rosters; account for all students.
- Be ready to move quickly if flooding threatens or move to lowest secure spot in the building.
- Remain in safe areas until warning(s) expire or emergency personnel have issued “all clear” advisories.
- Notify parents.
- Assist emergency personnel.



APPENDIX L

(STUDENT-ATHLETE NAME, IMAGE OR LIKENESS) NIL POLICY

This Policy sets forth the provisions that apply if a DeMatha student-athlete or prospective student-athlete (collectively sometimes referred to as "Student-Athlete") chooses to receive compensation for use of their NIL. Because of the changing regulatory landscape, DeMatha may need to amend, replace, or rescind this Policy if, for example, federal, state, conference, or other authorities adopt new or amended policies, requirements, or laws. DeMatha's Department of Athletics may publish additional materials to further clarify or implement this Policy.

NIL Defined

NIL activity is any activity in which a Student-Athlete's name, image, or likeness is used for promotional or commercial purposes. Such use may be compensated (e.g., cash, product, or other benefit).

Guidelines

The following provisions apply to DeMatha Student-Athletes who choose to use their NIL to earn compensation:

- Student-Athletes must comply with all applicable state and federal laws and regulations as well as all applicable policies or requirements of the WCAC, other applicable athletics association or governing body, and DeMatha.
- NIL compensation may not be related to pay-for-play, impermissible offers and inducements or extra benefits, including but not limited to:
- NIL agreements provided without quid pro quo (e.g., cannot be payments for work not performed);
- NIL payments provided or offered contingent on initial or continued enrollment at DeMatha;
- NIL payments contingent on specific athletic performance or achievement (e.g., financial incentives based on points scored). Athletic performance may enhance a Student-Athlete's NIL value but may not be "consideration" for NIL compensation.
- A Student-Athlete may not engage in any NIL activity in a manner that conflicts with a term of any DeMatha contract (for example, engaging in NIL activities for a competitor of any existing DeMatha sponsorship arrangement) or DeMatha's Student Handbook.
- A Student-Athlete may not use their NIL to promote casinos or gambling, including sports betting and the lottery; alcohol products; tobacco, nicotine, and electronic smoking products and devices; cannabis, cannabinoids, cannabidiol, or other derivatives; drug paraphernalia; controlled dangerous substances; prescription pharmaceuticals; adult entertainment, services, and products; video games, on-line games, and mobile devices; weapons, including firearms and ammunition; substances banned by the NCAA; or products or services that are illegal or that are contrary to the religious or academic mission of DeMatha.
- A Student-Athlete may not engage in any NIL activities on DeMatha property or during any school, athletics department, or school or team related activity (e.g., practice, competition, team meals, or any other activity organized by the athletics department or team).
- A Student-Athlete may not use or make reference to the name, symbols, logos, trademarks, facilities, and/or images associated with DeMatha or the WCAC, including not appearing in any athletic uniforms or gear (both game and practice) or academic school uniforms of DeMatha.
- A Student-Athlete must disclose all NIL activities to DeMatha in the manner set forth by the Department of Athletics.

Disclaimer

DeMatha is not providing and cannot provide legal advice to a Student-Athlete or his family. Compliance with this Policy does not ensure eligibility under the standards of other institutions or athletics organizations, including, but not limited to, the NCAA or other collegiate athletics association.

DeMatha is not permitted to assist Student-Athletes with identifying, selecting, arranging, or providing payment for professional service providers. DeMatha is not liable or otherwise responsible to any Student-Athlete, entity that partners with a Student-Athlete, professional service provider, or other person or entity involved with NIL activities or NIL related agreements with any Student-Athlete.

Changes to Policy

DeMatha, in its sole and absolute discretion, may amend or rescind this Policy at any time.



JULY						2023
S	M	T	W	T	F	S
						1
2	3	4	5	6	7	8
9	10	11	12	13	14	15
16	17	18	19	20	21	22
23	24	25	26	27	28	29
30	31					

AUGUST							2023
S	M	T	W	T	F	S	
		1	2	3	4	5	
6	7	8	9	10	11	12	
13	14	15	16	17	18	19	
20	21	22	23	24	25	26	
27	28	29	30	31			

SEPTEMBER							2023
S	M	T	W	T	F	S	
						1	
2	3	4	5	6	7	8	
9	10	11	12	13	14	15	
16	17	18	19	20	21	22	
23	24	25	26	27	28	29	
30	31						

MONDAY AUG. 21

Faculty Meetings

TUESDAY AUG. 22

Faculty Meetings
5:30 PM - 7:00 PM - Transfer Parents Cookout

hedonism n. – belief that pleasure is the sole aim in life. Hedonism and asceticism are opposite philosophies of human behavior.

WEDNESDAY AUG. 23

Faculty Meetings

Stags

“Nothing is so embarrassing as watching someone do something that you said couldn’t be done.” – Sam Ewing



THURSDAY AUG. 24

Opening Day 1

Freshman Experience

8:00 AM - 9:00 AM - Freshman Parent Coffee

FRIDAY AUG. 25

Opening Day 2

Freshman Experience

Transfer Opening Day

-pater- (*father*) – *paternalistic, patronize, paternity, patriarch, expatriate, paterfamilias*

SATURDAY AUG. 26 SUNDAY AUG. 27

SAT Date

<hr/> <hr/> <hr/> <hr/> <hr/> <hr/> <hr/> <hr/>	<hr/> <hr/> <hr/> <hr/> <hr/> <hr/> <hr/> <hr/>
---	---



JULY							2023
S	M	T	W	T	F	S	
						1	
2	3	4	5	6	7	8	
9	10	11	12	13	14	15	
16	17	18	19	20	21	22	
23	24	25	26	27	28	29	
30	31						

AUGUST							2023
S	M	T	W	T	F	S	
		1	2	3	4	5	
6	7	8	9	10	11	12	
13	14	15	16	17	18	19	
20	21	22	23	24	25	26	
27	28	29	30	31			

SEPTEMBER							2023
S	M	T	W	T	F	S	
						1	
2	3	4	5	6	7	8	
9	10	11	12	13	14	15	
16	17	18	19	20	21	22	
23	24	25	26	27	28	29	
30	31						

MONDAY AUG. 28

Opening Day- Sophomores, Juniors, Seniors
 Freshman- No Classes
 8:00 AM - 9:00 AM - Sophomore Parent Coffee

TUESDAY AUG. 29

Regular Classes- All Students

opulence n. – *wealth. Visitors from other countries are often amazed at the opulence in this country.*

WEDNESDAY AUG. 30

Stags

“I like pressure. If I am not on the edge of failure,
I’m not being sufficiently challenged.” – Jewel



THURSDAY

AUG. 31

8:00 AM - 9:00 AM - Junior Parent Coffee
Summer Service Hours Due
7:30 AM - 9:00 AM - Ring Measurements

FRIDAY

SEP. 1

NO CLASSES

-nov- (*new*) – *novel, nova, novice, novitate, Nova Scotia, innovation, renovate*

SATURDAY

SEP. 2

SUNDAY

SEP. 3



AUGUST 2023						
S	M	T	W	T	F	S
		1	2	3	4	5
6	7	8	9	10	11	12
13	14	15	16	17	18	19
20	21	22	23	24	25	26
27	28	29	30	31		

SEPTEMBER 2023						
S	M	T	W	T	F	S
					1	2
3	4	5	6	7	8	9
10	11	12	13	14	15	16
17	18	19	20	21	22	23
24	25	26	27	28	29	30

OCTOBER 2023						
S	M	T	W	T	F	S
1	2	3	4	5	6	7
8	9	10	11	12	13	14
15	16	17	18	19	20	21
22	23	24	25	26	27	28
29	30	31				

MONDAY SEP. 4

Labor Day
NO CLASSES

TUESDAY SEP. 5

7:00 PM - Back-to-School Night- 9th Grade ONLY

traverse v. – go through or across. When you traverse this field, be careful not to step on the wildflowers.

WEDNESDAY SEP. 6

Stago

“I can accept failure. Everyone fails at something.
But I can't accept not trying.” – Michael Jordan



THURSDAY

SEP. 7

FRIDAY

SEP. 8

Opening School Liturgy

-punct- (*point*) – *punctuate, punctilious, puncture, punctual, acupuncture, contrapuntal*

SATURDAY

SEP. 9

SUNDAY

SEP. 10

ACT
Voices of DeMatha Retreat
12:00 PM - 2:00 PM - Men of DM Cookout

<hr/> <hr/> <hr/> <hr/> <hr/> <hr/> <hr/> <hr/>	<hr/> <hr/> <hr/> <hr/> <hr/> <hr/> <hr/> <hr/>
---	---

Staga

“It’s lack of faith that makes people afraid of meeting challenges, and I believe in myself.” – Muhammad Ali



THURSDAY

SEP. 14

7:00 PM - Senior Parent Meeting
Virtual Back-to-School Night- ALL GRADES

FRIDAY

SEP. 15

Rosh Hashanah begins at sundown
Senior Pictures
Last day to Drop/Add Courses
Bake Sale- Freshman

-ject (*throw*) – *eject, reject, conjecture, dejected, inject, subject, projection, interject*

SATURDAY

SEP. 16

SUNDAY

SEP. 17

<hr/> <hr/> <hr/> <hr/> <hr/> <hr/> <hr/> <hr/>	<hr/> <hr/> <hr/> <hr/> <hr/> <hr/> <hr/> <hr/>
---	---



AUGUST		2023				
S	M	T	W	T	F	S
		1	2	3	4	5
6	7	8	9	10	11	12
13	14	15	16	17	18	19
20	21	22	23	24	25	26
27	28	29	30	31		

SEPTEMBER		2023				
S	M	T	W	T	F	S
					1	2
3	4	5	6	7	8	9
10	11	12	13	14	15	16
17	18	19	20	21	22	23
24	25	26	27	28	29	30

OCTOBER		2023				
S	M	T	W	T	F	S
1	2	3	4	5	6	7
8	9	10	11	12	13	14
15	16	17	18	19	20	21
22	23	24	25	26	27	28
29	30	31				

MONDAY SEP. 18

TUESDAY SEP. 19

Stag-for-a-day Visits Begin
Parent Organization Meeting (Uniform Measurements)

evasive adj. – not frank; not direct. Her evasive answers convinced the judge she was withholding important information.

WEDNESDAY SEP. 20

“Challenges make you discover things about yourself that you never really knew. They’re what make the instrument stretch – what make you go beyond the norm.” – Cicely Tyson



THURSDAY

SEP. 21

Tag Day for Walk-A-Thon
7:00 PM - Admissions Information Night (incoming students)

FRIDAY

SEP. 22

NHS Candidate Packet Available
Ring Measurements

-tion (*act or state*) – completion, reaction, devastation, production, creation, transition

SATURDAY

SEP. 23

SUNDAY

SEP. 24

First day of autumn
Alumni Reunions

Yom Kippur begins at sundown



AUGUST							2023	
S	M	T	W	T	F	S		
		1	2	3	4	5		
6	7	8	9	10	11	12		
13	14	15	16	17	18	19		
20	21	22	23	24	25	26		
27	28	29	30	31				

SEPTEMBER							2023	
S	M	T	W	T	F	S		
					1	2		
3	4	5	6	7	8	9		
10	11	12	13	14	15	16		
17	18	19	20	21	22	23		
24	25	26	27	28	29	30		

OCTOBER							2023	
S	M	T	W	T	F	S		
1	2	3	4	5	6	7		
8	9	10	11	12	13	14		
15	16	17	18	19	20	21		
22	23	24	25	26	27	28		
29	30	31						

MONDAY SEP. 25

TUESDAY SEP. 26

Mawlid al-Nabi begins at sundown

denouement n. – outcome; final development in a play. The denouement was obvious as early as the middle of the first act.

WEDNESDAY SEP. 27

“If you want to make peace with your enemy,
you have to work with your enemy. Then he
becomes your partner.” – Nelson Mandela



THURSDAY **SEP. 28**

Walk-A-Thon

FRIDAY **SEP. 29**

Faculty/Staff Retreat
NO CLASSES

-loc- (place) – locomotive, location, local, locus, relocate, dislocate, localize

SATURDAY **SEP. 30** **SUNDAY** **OCT. 1**

4:00 PM - 7:00 PM - Senior Booster Crab Feast
Service Hours Due

<hr/> <hr/> <hr/> <hr/> <hr/> <hr/> <hr/> <hr/>	<hr/> <hr/> <hr/> <hr/> <hr/> <hr/> <hr/> <hr/>
---	---



SEPTEMBER							2023	
S	M	T	W	T	F	S		
					1	2		
3	4	5	6	7	8	9		
10	11	12	13	14	15	16		
17	18	19	20	21	22	23		
24	25	26	27	28	29	30		

OCTOBER							2023	
S	M	T	W	T	F	S		
1	2	3	4	5	6	7		
8	9	10	11	12	13	14		
15	16	17	18	19	20	21		
22	23	24	25	26	27	28		
29	30	31						

NOVEMBER							2023	
S	M	T	W	T	F	S		
							1	2
							3	4
							5	6
							7	8
							9	10
							11	12
							13	14
							15	16
							17	18
							19	20
							21	22
							23	24
							25	26
							27	28
							29	30

MONDAY OCT. 2

Homecoming/Spirit Week

TUESDAY OCT. 3

Homecoming/Spirit Week

impale v. – pierce. *He was impaled by the spear his enemy hurled.*

WEDNESDAY OCT. 4

Homecoming/Spirit Week

Stags

“Courage is the ladder on which all the other virtues mount.” – Clare Boothe Luce



THURSDAY

OCT. 5

Homecoming/Spirit Week

FRIDAY

OCT. 6

Homecoming Game vs Gonzaga
Homecoming/Spirit Week

-dox- (*opinion*) – *orthodox, heterodox, doxology, indoctrinate, paradox*

SATURDAY

OCT. 7

SUNDAY

OCT. 8

SAT
Homecoming Dance

<hr/> <hr/> <hr/> <hr/> <hr/> <hr/> <hr/> <hr/>	<hr/> <hr/> <hr/> <hr/> <hr/> <hr/> <hr/> <hr/>
---	---



SEPTEMBER							2023	
S	M	T	W	T	F	S		
					1	2		
3	4	5	6	7	8	9		
10	11	12	13	14	15	16		
17	18	19	20	21	22	23		
24	25	26	27	28	29	30		

OCTOBER							2023	
S	M	T	W	T	F	S		
1	2	3	4	5	6	7		
8	9	10	11	12	13	14		
15	16	17	18	19	20	21		
22	23	24	25	26	27	28		
29	30	31						

NOVEMBER							2023	
S	M	T	W	T	F	S		
					1	2	3	4
5	6	7	8	9	10	11		
12	13	14	15	16	17	18		
19	20	21	22	23	24	25		
26	27	28	29	30				

MONDAY OCT. 9

Columbus Day
NO CLASSES

TUESDAY OCT. 10

penchant n. – strong inclination; liking. *She had a penchant for fine jewelry.*

WEDNESDAY OCT. 11

Standardized Testing 10th & 11th Grade
7:00 PM - Admissions Information Night

“Some of the world’s greatest feats were accomplished by people not smart enough to know they were impossible.” – Doug Larson



THURSDAY **OCT. 12**

FRIDAY **OCT. 13**

amphi- (*both*) – *amphibious, amphitheater, amphibian, amphibole*

SATURDAY **OCT. 14** **SUNDAY** **OCT. 15**

6:00 PM - Kaleidoscope Concert

“Never doubt that a small group of thoughtful, committed citizens can change the world. Indeed, it is the only thing that ever has.” – Margaret Mead



THURSDAY

OCT. 19

9:00 AM - 2:00 PM - Middle School Science Teacher Workshop

FRIDAY

OCT. 20

Ring Measurements Order Deadline Due

magn- (*great*) – *Magna Carta, magnanimous, magnate, magnificent, magnum opus*

SATURDAY

OCT. 21

SUNDAY

OCT. 22

Reunion Class of '88

<hr/> <hr/> <hr/> <hr/> <hr/> <hr/> <hr/> <hr/>	<hr/> <hr/> <hr/> <hr/> <hr/> <hr/> <hr/> <hr/>
---	---



SEPTEMBER							2023	
S	M	T	W	T	F	S		
					1	2		
3	4	5	6	7	8	9		
10	11	12	13	14	15	16		
17	18	19	20	21	22	23		
24	25	26	27	28	29	30		

OCTOBER							2023	
S	M	T	W	T	F	S		
1	2	3	4	5	6	7		
8	9	10	11	12	13	14		
15	16	17	18	19	20	21		
22	23	24	25	26	27	28		
29	30	31						

NOVEMBER							2023	
S	M	T	W	T	F	S		
					1	2	3	4
5	6	7	8	9	10	11		
12	13	14	15	16	17	18		
19	20	21	22	23	24	25		
26	27	28	29	30				

MONDAY OCT. 23

Yearbook Pictures

TUESDAY OCT. 24

restitution n. – payment for damage or loss. He offered to make restitution for the window he broke.

WEDNESDAY OCT. 25

Stags

“You can always wish for what you don’t have, but always respect what you do have.” – Suzanne Vermilyea



THURSDAY

OCT. 26

End of Quarter 1
NHS Candidate Packet Due

FRIDAY

OCT. 27

Cyber Day
HSPA Professional Day

eu- (good) – Eucharist, euphony, eulogy, euphemism, Europe, eugenics

SATURDAY

OCT. 28

SUNDAY

OCT. 29

ACT

<hr/> <hr/> <hr/> <hr/> <hr/> <hr/> <hr/> <hr/>	<hr/> <hr/> <hr/> <hr/> <hr/> <hr/> <hr/> <hr/>
---	---

Stags

“If there is to be any peace it will come through being, not having.” – Henry Miller



THURSDAY

Nov. 2

Feast of All Souls
Tag Day- Food Drive

FRIDAY

Nov. 3

endo- (*within*) – *endoplasm, endocrine, endogamous, endoskeleton, endothermic*

SATURDAY

Nov. 4

SUNDAY

Nov. 5

SAT

Standard time begins
10:30 AM - 1:30 PM - Open House

<hr/> <hr/> <hr/> <hr/> <hr/> <hr/> <hr/> <hr/>	<hr/> <hr/> <hr/> <hr/> <hr/> <hr/> <hr/> <hr/>
---	---



OCTOBER							2023						
S	M	T	W	T	F	S	S	M	T	W	T	F	S
1	2	3	4	5	6	7							
8	9	10	11	12	13	14							
15	16	17	18	19	20	21							
22	23	24	25	26	27	28							
29	30	31											

NOVEMBER							2023						
S	M	T	W	T	F	S	S	M	T	W	T	F	S
				1	2	3	4						
5	6	7	8	9	10	11							
12	13	14	15	16	17	18							
19	20	21	22	23	24	25							
26	27	28	29	30									

DECEMBER							2023						
S	M	T	W	T	F	S	S	M	T	W	T	F	S
						1	2						
3	4	5	6	7	8	9							
10	11	12	13	14	15	16							
17	18	19	20	21	22	23							
24	25	26	27	28	29	30	31						

MONDAY Nov. 6

Senior Pictures

TUESDAY Nov. 7

Election Day
Senior Pictures

frugality n. – thrift. We must live with frugality if we are to get ahead financially.

WEDNESDAY Nov. 8

Winter Sports Begin

“To fulfill a dream, to be allowed to sweat over lonely labor, to be given a chance to create, is the meat and potatoes of life.” – Bette Davis



THURSDAY Nov. 9

4:00 PM - 7:00 PM - Parent-Teacher Conferences

FRIDAY Nov. 10

Faculty Meeting
NO CLASSES

-phobia (*fear*) – *claustrophobia, acrophobia, xenophobia, agoraphobia, hydrophobia*

SATURDAY Nov. 11 **SUNDAY** Nov. 12

Veterans Day

<hr/> <hr/> <hr/> <hr/> <hr/> <hr/> <hr/> <hr/>	<hr/> <hr/> <hr/> <hr/> <hr/> <hr/> <hr/> <hr/>
---	---

Stags

“There is no man living who isn’t capable of doing more than he thinks he can do.” – Henry Ford



THURSDAY

Nov. 16

7:00 PM - College Process (Jrs.) Meeting

FRIDAY

Nov. 17

Food Drive Ends
Bake Sale- Sophomores
DM Players Fall Play

ortho- (*straight*) – *orthopedics, orthodontist, orthodox, orthography, orthogonal*

SATURDAY

Nov. 18

SUNDAY

Nov. 19

Music Dept. 5k
DM Players Fall Play

DM Players Fall Play

Stags

“You really can change the world if you care enough.” – Marian Wright Edelman



THURSDAY

Nov. 23

Thanksgiving
Thanksgiving Holiday

FRIDAY

Nov. 24

Thanksgiving Holiday

-put- (*think*) – *reputation, putative, impute, dispute, computer, disreputable*

SATURDAY

Nov. 25

SUNDAY

Nov. 26

Advent Begins

<hr/> <hr/> <hr/> <hr/> <hr/> <hr/> <hr/> <hr/>	<hr/> <hr/> <hr/> <hr/> <hr/> <hr/> <hr/> <hr/>
---	---



OCTOBER							2023	
S	M	T	W	T	F	S		
1	2	3	4	5	6	7		
8	9	10	11	12	13	14		
15	16	17	18	19	20	21		
22	23	24	25	26	27	28		
29	30	31						

NOVEMBER							2023	
S	M	T	W	T	F	S		
				1	2	3	4	
5	6	7	8	9	10	11		
12	13	14	15	16	17	18		
19	20	21	22	23	24	25		
26	27	28	29	30				

DECEMBER							2023	
S	M	T	W	T	F	S		
						1	2	
3	4	5	6	7	8	9		
10	11	12	13	14	15	16		
17	18	19	20	21	22	23		
24	25	26	27	28	29	30		
31								

MONDAY Nov. 27

TUESDAY Nov. 28

Toy Drive Begins

glut n. – overstock; fill to excess. *The glut of athletic shoes gives buyers lots of choices.*

WEDNESDAY Nov. 29

Stags

“Action is the antidote to despair.” – Joan Baez



THURSDAY

Nov. 30

Service Hours Due

FRIDAY

DEC. 1

-ver- (true) – verify, veracity, veritable, verdict, verisimilitude, aver, cinema verity

SATURDAY

DEC. 2

SUNDAY

DEC. 3

HSPT
WAMTC Band Adjudication Festival
SAT

Stags

“The time is always right to do what is right.” – Martin Luther King Jr.



THURSDAY

DEC. 7

Hanukkah begins at sundown

7:00 PM - Fall Concert-CBI/PEI, CS, CB, CBI

FRIDAY

DEC. 8

Feast of the Immaculate Conception (Mass)

Toy Drive Ends

matri- (*mother*) – *matricide, matron, matriarch, matrimony, matrilineal*

SATURDAY

DEC. 9

SUNDAY

DEC. 10

ACT

Stags

“Where there is great love there are always miracles.” – Willa Cather



THURSDAY

DEC. 14

7:00 PM - College Process Meeting (Jrs.)
7:00 PM - Fall Concert- Wind Ensemble and Sinfonia

FRIDAY

DEC. 15

Mass- St. John de Matha Day

mega- (large) – megalith, megaphone, megalomania, megalopolis, megahertz

SATURDAY

DEC. 16

SUNDAY

DEC. 17

Faculty/Staff Family Open House

Actual Feast Day of St. John de Matha

<hr/> <hr/> <hr/> <hr/> <hr/> <hr/> <hr/> <hr/>	<hr/> <hr/> <hr/> <hr/> <hr/> <hr/> <hr/> <hr/>
---	---

Stags

"It's kind of fun to do the impossible." – Walt Disney



THURSDAY

DEC. 21

First day of winter
Christmas Holiday

FRIDAY

DEC. 22

Christmas Holiday

pop- (people) – popular, populist, populate, population, popularize, populous

SATURDAY

DEC. 23

SUNDAY

DEC. 24

<hr/> <hr/> <hr/> <hr/> <hr/> <hr/> <hr/> <hr/> <hr/> <hr/>	<hr/> <hr/> <hr/> <hr/> <hr/> <hr/> <hr/> <hr/> <hr/> <hr/>
---	---



NOVEMBER							2023	
S	M	T	W	T	F	S		
			1	2	3	4		
5	6	7	8	9	10	11		
12	13	14	15	16	17	18		
19	20	21	22	23	24	25		
26	27	28	29	30				

DECEMBER							2023	
S	M	T	W	T	F	S		
					1	2		
3	4	5	6	7	8	9		
10	11	12	13	14	15	16		
17	18	19	20	21	22	23		
24	25	26	27	28	29	30		
31								

JANUARY							2024	
S	M	T	W	T	F	S		
	1	2	3	4	5	6		
7	8	9	10	11	12	13		
14	15	16	17	18	19	20		
21	22	23	24	25	26	27		
28	29	30	31					

MONDAY DEC. 25

Christmas- Birth of Our Savior
Christmas Holiday

TUESDAY DEC. 26

Kwanzaa begins
Christmas Holiday

ornithology n. – study of birds. *John James Audubon was a famous scholar of ornithology.*

WEDNESDAY DEC. 27

Christmas Holiday

Stags

“Truth is the only safe ground to stand upon.” – Elizabeth Cady Stanton



THURSDAY

DEC. 28

Christmas Holiday

FRIDAY

DEC. 29

Christmas Holiday

-sangui- (blood) – sanguinary, sanguine, consanguinity, sangria

SATURDAY

DEC. 30

SUNDAY

DEC. 31

Service Hours Due



DECEMBER						2023	
S	M	T	W	T	F	S	
					1	2	
3	4	5	6	7	8	9	
10	11	12	13	14	15	16	
17	18	19	20	21	22	23	
24	25	26	27	28	29	30	
31							

JANUARY							2024	
S	M	T	W	T	F	S		
	1	2	3	4	5	6		
7	8	9	10	11	12	13		
14	15	16	17	18	19	20		
21	22	23	24	25	26	27		
28	29	30	31					

FEBRUARY							2024	
S	M	T	W	T	F	S		
					1	2	3	
4	5	6	7	8	9	10		
11	12	13	14	15	16	17		
18	19	20	21	22	23	24		
25	26	27	28	29				

MONDAY JAN. 1

New Year's Day

TUESDAY JAN. 2

Classes Resume

supple *adj.* – flexible; pliant. *The fisherman found a supple tree limb to use as a fishing rod.*

WEDNESDAY JAN. 3

Stags

“No man fails if he does his best.”
– Orison Swett Marden



THURSDAY

JAN. 4

FRIDAY

JAN. 5

vita- (*life*) – *vitamin, vitality, vital, revitalize, viable, vitalize*

SATURDAY

JAN. 6

SUNDAY

JAN. 7

<hr/> <hr/> <hr/> <hr/> <hr/> <hr/> <hr/> <hr/>	<hr/> <hr/> <hr/> <hr/> <hr/> <hr/> <hr/> <hr/>
---	---



DECEMBER 2023						
S	M	T	W	T	F	S
					1	2
3	4	5	6	7	8	9
10	11	12	13	14	15	16
17	18	19	20	21	22	23
24	25	26	27	28	29	30
31						

JANUARY 2024						
S	M	T	W	T	F	S
	1	2	3	4	5	6
7	8	9	10	11	12	13
14	15	16	17	18	19	20
21	22	23	24	25	26	27
28	29	30	31			

FEBRUARY 2024						
S	M	T	W	T	F	S
					1	2
3	4	5	6	7	8	9
10	11	12	13	14	15	16
17	18	19	20	21	22	23
24	25	26	27	28	29	

MONDAY JAN. 8

TUESDAY JAN. 9

itinerary n. – plan of a trip. She left her itinerary with us in case we need to contact her.

WEDNESDAY JAN. 10

NHS Induction

“The formula for success is simple: practice and concentration then more practice and more concentration.” – Babe Didrikson Zaharias



THURSDAY **JAN. 11**

FRIDAY **JAN. 12**

End of Quarter 2

demo- (people) – democracy, demography, undemocratic, democratize

SATURDAY **JAN. 13** **SUNDAY** **JAN. 14**

<hr/> <hr/> <hr/> <hr/> <hr/> <hr/> <hr/> <hr/>	<hr/> <hr/> <hr/> <hr/> <hr/> <hr/> <hr/> <hr/>
---	---



DECEMBER 2023						
S	M	T	W	T	F	S
					1	2
3	4	5	6	7	8	9
10	11	12	13	14	15	16
17	18	19	20	21	22	23
24	25	26	27	28	29	30
31						

JANUARY 2024						
S	M	T	W	T	F	S
	1	2	3	4	5	6
7	8	9	10	11	12	13
14	15	16	17	18	19	20
21	22	23	24	25	26	27
28	29	30	31			

FEBRUARY 2024						
S	M	T	W	T	F	S
					1	2
3	4	5	6	7	8	9
10	11	12	13	14	15	16
17	18	19	20	21	22	23
24	25	26	27	28	29	

MONDAY JAN. 15

Martin Luther King Jr. Day

TUESDAY JAN. 16

DeMatha Experience

coerce v. –force. Don't try to coerce me into doing this.

WEDNESDAY JAN. 17

DeMatha Experience

Staga

“For how can ‘the consent of the governed’ be given, if the right to vote be denied?” – Susan B. Anthony



THURSDAY **JAN. 18**

DeMatha Experience

FRIDAY **JAN. 19**

DeMatha Experience
March for Life

stereo- (solid) – stereoscope, stereophonic, stereotype, stereopticon, stereotropism

SATURDAY **JAN. 20** **SUNDAY** **JAN. 21**

<hr/> <hr/> <hr/> <hr/> <hr/> <hr/> <hr/> <hr/> <hr/> <hr/>	<hr/> <hr/> <hr/> <hr/> <hr/> <hr/> <hr/> <hr/> <hr/> <hr/>
---	---

Stargazer

“You cannot achieve a new goal by applying the same level of thinking that got you where you are today.” – Albert Einstein



THURSDAY JAN. 25

4:00 PM - 7:00 PM - Parent-Teacher Conferences

FRIDAY JAN. 26

Faculty Meeting
NO CLASSES

-ism (doctrine) – *Marxism, capitalism, Imagism, Cubism, nihilism, pluralism*

SATURDAY JAN. 27 **SUNDAY** JAN. 28

<hr/> <hr/> <hr/> <hr/> <hr/> <hr/> <hr/> <hr/> <hr/> <hr/>	<hr/> <hr/> <hr/> <hr/> <hr/> <hr/> <hr/> <hr/> <hr/> <hr/>
---	---



DECEMBER						2023	
S	M	T	W	T	F	S	
					1	2	
3	4	5	6	7	8	9	
10	11	12	13	14	15	16	
17	18	19	20	21	22	23	
24	25	26	27	28	29	30	
31							

JANUARY							2024	
S	M	T	W	T	F	S		
	1	2	3	4	5	6		
7	8	9	10	11	12	13		
14	15	16	17	18	19	20		
21	22	23	24	25	26	27		
28	29	30	31					

FEBRUARY							2024	
S	M	T	W	T	F	S		
					1	2	3	
4	5	6	7	8	9	10		
11	12	13	14	15	16	17		
18	19	20	21	22	23	24		
25	26	27	28	29				

MONDAY JAN. 29

TUESDAY JAN. 30

8:15 AM - 9:00 AM - Freshman Parent Coffee

amble v. – move at an easy pace. He ambled around the town.

WEDNESDAY JAN. 31

8:15 AM - 9:00 AM - Sophomore Parent Coffee
Service Hours Due

Stags

“Laziness may appear attractive, but work gives satisfaction.” – Anne Frank



THURSDAY

FEB. 1

8:15 AM - 9:00 AM - Junior Parent Coffee
BSU Tag Day

FRIDAY

FEB. 2

Groundhog Day
Last Day to Add/Drop Courses

cognosc-, -cognit- (to learn) – agnostic, incognito, cognition

SATURDAY

FEB. 3

SUNDAY

FEB. 4

Academic Challenge



JANUARY 2024						
S	M	T	W	T	F	S
	1	2	3	4	5	6
7	8	9	10	11	12	13
14	15	16	17	18	19	20
21	22	23	24	25	26	27
28	29	30	31			

FEBRUARY 2024						
S	M	T	W	T	F	S
				1	2	3
4	5	6	7	8	9	10
11	12	13	14	15	16	17
18	19	20	21	22	23	24
25	26	27	28	29		

MARCH 2024						
S	M	T	W	T	F	S
					1	2
3	4	5	6	7	8	9
10	11	12	13	14	15	16
17	18	19	20	21	22	23
24	25	26	27	28	29	30
31						

MONDAY FEB. 5

TUESDAY FEB. 6

epitome n. – a representative or example of a type. He is the epitome of a male chauvinist.

WEDNESDAY FEB. 7

Junior Retreat
Cyber Day 9th, 10th, 12th Grades

“The world is round, and the place which
may seem like the end may also be only
the beginning.” – Ivy Baker Priest



THURSDAY

FEB. 8

FRIDAY

FEB. 9

Bake Sale- Juniors

-graph-, -gram (*writing*) – *epigram, telegram, stenography*

SATURDAY

FEB. 10

SUNDAY

FEB. 11

Lunar New Year
ACT
DPO- Bull Roast

<hr/> <hr/> <hr/> <hr/> <hr/> <hr/> <hr/> <hr/>	<hr/> <hr/> <hr/> <hr/> <hr/> <hr/> <hr/> <hr/>
---	---



JANUARY 2024						
S	M	T	W	T	F	S
	1	2	3	4	5	6
7	8	9	10	11	12	13
14	15	16	17	18	19	20
21	22	23	24	25	26	27
28	29	30	31			

FEBRUARY 2024						
S	M	T	W	T	F	S
					1	2
3	4	5	6	7	8	9
10	11	12	13	14	15	16
17	18	19	20	21	22	23
24	25	26	27	28	29	

MARCH 2024						
S	M	T	W	T	F	S
						1
2	3	4	5	6	7	8
9	10	11	12	13	14	15
16	17	18	19	20	21	22
23	24	25	26	27	28	29
30	31					

MONDAY FEB. 12

Lincoln's Birthday
Cyber Day

TUESDAY FEB. 13

All ATS (Physicals) Info for Spring Sports Due
DMLI Tag Day

adhere v. – *stick fast. I will adhere to my opinion until I'm proven wrong.*

WEDNESDAY FEB. 14

Ash Wednesday
Valentine's Day

Stags

“Without discipline, there is no life at all.” – Katharine Hepburn



THURSDAY

FEB. 15

Re-Enrollment Day

FRIDAY

FEB. 16

-ile (*pertaining to, capable of*) – civil, ductile, puerile

SATURDAY

FEB. 17

SUNDAY

FEB. 18

<hr/> <hr/> <hr/> <hr/> <hr/> <hr/> <hr/> <hr/> <hr/> <hr/>	<hr/> <hr/> <hr/> <hr/> <hr/> <hr/> <hr/> <hr/> <hr/> <hr/>
---	---

Stags

“Attempt the impossible in order to improve your work.” – Bette Davis



THURSDAY

FEB. 22

Washington's Birthday

7:00 PM - College Process Meeting (Jrs.)

FRIDAY

FEB. 23

-dict- (to say) – abdicate, diction, verdict

SATURDAY

FEB. 24

SUNDAY

FEB. 25



JANUARY 2024						
S	M	T	W	T	F	S
	1	2	3	4	5	6
7	8	9	10	11	12	13
14	15	16	17	18	19	20
21	22	23	24	25	26	27
28	29	30	31			

FEBRUARY 2024						
S	M	T	W	T	F	S
				1	2	3
4	5	6	7	8	9	10
11	12	13	14	15	16	17
18	19	20	21	22	23	24
25	26	27	28	29		

MARCH 2024						
S	M	T	W	T	F	S
					1	2
3	4	5	6	7	8	9
10	11	12	13	14	15	16
17	18	19	20	21	22	23
24	25	26	27	28	29	30
31						

MONDAY FEB. 26

TUESDAY FEB. 27

infamous adj. – notoriously bad. *Jesse James was an infamous outlaw.*

WEDNESDAY FEB. 28

Stags

“Adventure is worthwhile in itself.” – Amelia Earhart



THURSDAY

FEB. 29

Service Hours Due

FRIDAY

MAR. 1

ab-, abs- (*from, away from*) – *abduct, abdicate, absent*

SATURDAY

MAR. 2

SUNDAY

MAR. 3

9:00 AM - Nusca Scholar Breakfast

<hr/> <hr/> <hr/> <hr/> <hr/> <hr/> <hr/> <hr/> <hr/> <hr/>	<hr/> <hr/> <hr/> <hr/> <hr/> <hr/> <hr/> <hr/> <hr/> <hr/>
---	---

Stages

“Once you realize how good you really are, you never settle for playing less than your best.” – Reggie Jackson



THURSDAY MAR. 7

FRIDAY MAR. 8

New Student Enrollment Due

-jur-, -jurat- (to swear) – abjure, perjure, jury

SATURDAY MAR. 9 **SUNDAY** MAR. 10

SAT

Daylight saving time begins
Ramadan begins at sundown

“This is the team. We’re trying to go to the moon. If you can’t put someone up, please don’t put them down.” – NASA motto



THURSDAY **MAR. 14**

Senior Service Interviews

FRIDAY **MAR. 15**

End of Quarter 3
Muffin Madness
NHS Tag Day
Senior Service Interviews

-solv-, -solut- (to loosen, explain) – absolve, dissolute, absolute

SATURDAY **MAR. 16** **SUNDAY** **MAR. 17**

St. Patrick's Day



FEBRUARY		2024				
S	M	T	W	T	F	S
				1	2	3
4	5	6	7	8	9	10
11	12	13	14	15	16	17
18	19	20	21	22	23	24
25	26	27	28	29		

MARCH		2024				
S	M	T	W	T	F	S
					1	2
3	4	5	6	7	8	9
10	11	12	13	14	15	16
17	18	19	20	21	22	23
24	25	26	27	28	29	30
31						

APRIL		2024				
S	M	T	W	T	F	S
	1	2	3	4	5	6
7	8	9	10	11	12	13
14	15	16	17	18	19	20
21	22	23	24	25	26	27
28	29	30				

MONDAY MAR. 18

TUESDAY MAR. 19

First day of spring
7:00 PM - College Process Meeting (Jrs.)

antipathy n. – *aversion. The author had a fundamental antipathy to reading on a tablet computer.*

WEDNESDAY MAR. 20

Senior Service Reflection Papers Due

Stags

“If it had not been for the wind in my face, I wouldn’t be able to fly at all.” – Arthur Ashe



THURSDAY

MAR. 21

MANDATORY Senior Parent Meeting

FRIDAY

MAR. 22

-cord- (*heart*) – *accord, cordial, discord*

SATURDAY

MAR. 23

SUNDAY

MAR. 24

Palm Sunday



FEBRUARY							2024	
S	M	T	W	T	F	S		
					1	2	3	
4	5	6	7	8	9	10		
11	12	13	14	15	16	17		
18	19	20	21	22	23	24		
25	26	27	28	29				

MARCH							2024	
S	M	T	W	T	F	S		
					1	2		
3	4	5	6	7	8	9		
10	11	12	13	14	15	16		
17	18	19	20	21	22	23		
24	25	26	27	28	29	30		
31								

APRIL							2024	
S	M	T	W	T	F	S		
	1	2	3	4	5	6		
7	8	9	10	11	12	13		
14	15	16	17	18	19	20		
21	22	23	24	25	26	27		
28	29	30						

MONDAY MAR. 25

TUESDAY MAR. 26

Jazz Band/Percussion Ensemble Concert

ruddy adj. – having a healthy red color. The baby's ruddy skin was a sign of good health.

WEDNESDAY MAR. 27

Stags

“I have found that among its other benefits, giving liberates the soul of the giver.” – Maya Angelou



THURSDAY

MAR. 28

Spring Break/Easter Holiday

FRIDAY

MAR. 29

Good Friday
Spring Break/Easter Holiday

acr- (*sharp*) – *acrimonious, acerbity, acidulate*

SATURDAY

MAR. 30

SUNDAY

MAR. 31

Spring Break/Easter Holiday

Easter
Service Hours Due
Spring Break/Easter Holiday



MARCH							2024	
S	M	T	W	T	F	S		
					1	2		
3	4	5	6	7	8	9		
10	11	12	13	14	15	16		
17	18	19	20	21	22	23		
24	25	26	27	28	29	30		
31								

APRIL							2024	
S	M	T	W	T	F	S		
	1	2	3	4	5	6		
7	8	9	10	11	12	13		
14	15	16	17	18	19	20		
21	22	23	24	25	26	27		
28	29	30						

MAY							2024	
S	M	T	W	T	F	S		
		1	2	3	4			
5	6	7	8	9	10	11		
12	13	14	15	16	17	18		
19	20	21	22	23	24	25		
26	27	28	29	30	31			

MONDAY APR. 1

April Fools' Day
Spring Break/Easter Holiday

TUESDAY APR. 2

Spring Break/Easter Holiday

maudlin adj. – tearfully sentimental. I am annoyed when a movie turns needlessly maudlin.

WEDNESDAY APR. 3

Spring Break/Easter Holiday

Stags

“The harder you work, the harder it is to surrender.” – Vince Lombardi



THURSDAY

APR. 4

Laylat al-Qadr begins at sundown
Spring Break/Easter Holiday

FRIDAY

APR. 5

Spring Break/Easter Holiday

-ag-, -act- (to do) – act, agent, retroactive

SATURDAY

APR. 6

SUNDAY

APR. 7

<hr/> <hr/> <hr/> <hr/> <hr/> <hr/> <hr/> <hr/>	<hr/> <hr/> <hr/> <hr/> <hr/> <hr/> <hr/> <hr/>
---	---



MARCH							2024	
S	M	T	W	T	F	S		
					1	2		
3	4	5	6	7	8	9		
10	11	12	13	14	15	16		
17	18	19	20	21	22	23		
24	25	26	27	28	29	30		
31								

APRIL							2024	
S	M	T	W	T	F	S		
	1	2	3	4	5	6		
7	8	9	10	11	12	13		
14	15	16	17	18	19	20		
21	22	23	24	25	26	27		
28	29	30						

MAY							2024	
S	M	T	W	T	F	S		
		1	2	3	4			
5	6	7	8	9	10	11		
12	13	14	15	16	17	18		
19	20	21	22	23	24	25		
26	27	28	29	30	31			

MONDAY APR. 8

Classes Resume _____
 Senior (ONLY) Spring Uniform _____

TUESDAY APR. 9

Eid al-Fitr begins at sundown
 Music Trip Parent Meeting _____

vilify v. – make abusive and slanderous statements toward someone. *The Nazi propaganda vilified the Jews.*

WEDNESDAY APR. 10

Music Trip Parent Meeting _____

Stags

“The quality of an individual is reflected in the standards they set for themselves.” – Ray Kroc



THURSDAY

APR. 11

FRIDAY

APR. 12

ad- (to, forward) – admit, adhere, advance

SATURDAY

APR. 13

SUNDAY

APR. 14

ACT

<hr/> <hr/> <hr/> <hr/> <hr/> <hr/> <hr/> <hr/>	<hr/> <hr/> <hr/> <hr/> <hr/> <hr/> <hr/> <hr/>
---	---

Stags

“Nothing in life is to be feared. It is only to be understood.” – Marie Curie



THURSDAY

APR. 18

Music Trip

FRIDAY

APR. 19

Music Trip

-mon-, -monit- (to warn) – admonish, premonition, monitor

SATURDAY

APR. 20

SUNDAY

APR. 21

Music Trip

<hr/> <hr/> <hr/> <hr/> <hr/> <hr/> <hr/> <hr/>	<hr/> <hr/> <hr/> <hr/> <hr/> <hr/> <hr/> <hr/>
---	---

Staga

“Common sense is seeing things as they are and doing things as they ought to be.” – Harriet Beecher Stowe



THURSDAY

APR. 25

FRIDAY

APR. 26

DM Players Spring Play

agri-, agrari- (field) – agrarian, agriculture

SATURDAY

APR. 27

SUNDAY

APR. 28

DM Players Spring Play Sunday, April 28

DM Players Spring Play

<hr/> <hr/> <hr/> <hr/> <hr/> <hr/> <hr/> <hr/>	<hr/> <hr/> <hr/> <hr/> <hr/> <hr/> <hr/> <hr/>
---	---



APRIL		2024				
S	M	T	W	T	F	S
	1	2	3	4	5	6
7	8	9	10	11	12	13
14	15	16	17	18	19	20
21	22	23	24	25	26	27
28	29	30				

MAY		2024				
S	M	T	W	T	F	S
			1	2	3	4
5	6	7	8	9	10	11
12	13	14	15	16	17	18
19	20	21	22	23	24	25
26	27	28	29	30	31	

JUNE		2024				
S	M	T	W	T	F	S
						1
2	3	4	5	6	7	8
9	10	11	12	13	14	15
16	17	18	19	20	21	22
23	24	25	26	27	28	29
30						

MONDAY APR. 29

TUESDAY APR. 30

Service Hours Due

steadfast adj. – firm; unwavering. The president spoke with steadfast resolve.

WEDNESDAY MAY 1

Stags

“No one can make you feel inferior without your consent.” – Eleanor Roosevelt



THURSDAY

MAY 2

7:00 PM - Spring Concert- CB/CB II/CB I/PE I/CS

FRIDAY

MAY 3

Jr/Sr Prom
No Classes for Seniors
Early Dismissal

-ali- (*another*) – *alias, alienate, inalienable*

SATURDAY

MAY 4

SUNDAY

MAY 5

SAT

Cinco de Mayo
Mother/Son Luncheon

Stags

“There are no gains without pains.”
– Benjamin Franklin



THURSDAY

MAY 9

AP EXAMS

FRIDAY

MAY 10

AP EXAMS

alter- (other) – alternator, alteration, alter ego, alternative, altruism, altercation

SATURDAY

MAY 11

SUNDAY

MAY 12

9:00 AM - Placement Test
Uniform Measurements

Mother's Day

<hr/> <hr/> <hr/> <hr/> <hr/> <hr/> <hr/> <hr/> <hr/> <hr/>	<hr/> <hr/> <hr/> <hr/> <hr/> <hr/> <hr/> <hr/> <hr/> <hr/>
---	---

“Do the best you can in every task, no matter how unimportant it may seem at the time. No one learns more about a problem than the person at the bottom.” – Sandra Day O’Connor



THURSDAY

MAY 16

AP EXAMS

Senior Exams

Senior/Faculty Picnic

10:30 AM - Graduation Practice

FRIDAY

MAY 17

AP EXAMS

Senior Exams

amat- (love) – *amatory, amateur, amorous, amiable, amigo, amour*

SATURDAY

MAY 18

SUNDAY

MAY 19

Music Award Night

Stags

“Make the most of yourself, for that is all there is of you.” – Ralph Waldo Emerson



THURSDAY

MAY 23

FRIDAY

MAY 24

End of School Mass
Underclassmen Service Hours Due

ambi- (both) – ambidextrous, ambiguous, ambivalent

SATURDAY

MAY 25

SUNDAY

MAY 26

<hr/> <hr/> <hr/> <hr/> <hr/> <hr/> <hr/> <hr/>	<hr/> <hr/> <hr/> <hr/> <hr/> <hr/> <hr/> <hr/>
---	---

Stags

“If you really want something, you can figure out how to make it happen.” – Cher



THURSDAY

MAY 30

Locker Clean Out
Underclassmen Exams

FRIDAY

MAY 31

Underclassmen Exams

an- (without) – *anarchy, anemia, anesthesia*

SATURDAY

JUNE 1

SUNDAY

JUNE 2

SAT

<hr/> <hr/> <hr/> <hr/> <hr/> <hr/> <hr/> <hr/>	<hr/> <hr/> <hr/> <hr/> <hr/> <hr/> <hr/> <hr/>
---	---

Stags

“The price of greatness is responsibility.”
– Winston Churchill



THURSDAY

JUNE 6

Faculty Meetings

FRIDAY

JUNE 7

9:00 AM - Graduation- National Shrine

-arch- (*ruler, first*) – *anarchy, archeology, archbishop*

SATURDAY

JUNE 8

SUNDAY

JUNE 9

ACT

<hr/> <hr/> <hr/> <hr/> <hr/> <hr/> <hr/> <hr/>	<hr/> <hr/> <hr/> <hr/> <hr/> <hr/> <hr/> <hr/>
---	---

Stags

“We can learn even from our enemies.” – Ovid



THURSDAY

JUNE 13

FRIDAY

JUNE 14

Flag Day

-anim- (mind, soul) – animadvert, unanimous, magnanimity

SATURDAY

JUNE 15

SUNDAY

JUNE 16

9:00 AM - New Student Placement Exam
Uniform Measurements

*Eid al-Adha begins at sundown
Father's Day*

<hr/> <hr/> <hr/> <hr/> <hr/> <hr/> <hr/> <hr/>	<hr/> <hr/> <hr/> <hr/> <hr/> <hr/> <hr/> <hr/>
---	---



MAY							2024						
S	M	T	W	T	F	S	S	M	T	W	T	F	S
							1	2	3	4			
5	6	7	8	9	10	11	12	13	14	15	16	17	18
19	20	21	22	23	24	25	26	27	28	29	30	31	

JUNE							2024						
S	M	T	W	T	F	S	S	M	T	W	T	F	S
													1
2	3	4	5	6	7	8	9	10	11	12	13	14	15
16	17	18	19	20	21	22	23	24	25	26	27	28	29
30													

JULY							2024						
S	M	T	W	T	F	S	S	M	T	W	T	F	S
							1	2	3	4	5	6	
7	8	9	10	11	12	13	14	15	16	17	18	19	20
21	22	23	24	25	26	27	28	29	30	31			

MONDAY JUNE 17

Summer Prep Session Begins
DMLI

TUESDAY JUNE 18

DMLI

levity n. – lightness. The boy's levity toward the serious situation was bothersome.

WEDNESDAY JUNE 19

Juneteenth
DMLI- Off Campus
NO CLASSES

Stags

“We must use time as a tool, not as a crutch.” – John F. Kennedy



THURSDAY

JUNE 20

First day of summer
Summer HS Begins

FRIDAY

JUNE 21

-annu- (year) – annuity, biennial, perennial

SATURDAY

JUNE 22

SUNDAY

JUNE 23

<hr/> <hr/> <hr/> <hr/> <hr/> <hr/> <hr/> <hr/>	<hr/> <hr/> <hr/> <hr/> <hr/> <hr/> <hr/> <hr/>
---	---

JUNE 2024

★ GOALS

MONDAY	TUESDAY	WEDNESDAY	THURSDAY
27	28	29	30
3	Faculty Meetings	4	Faculty Meetings
		5	6
		11:00 AM - Graduation Practice @ Shrine 4:00 PM - Baccalaureate Mass	
10	11	12	13
Summer Prep Session Begins DMLI	17	DMLI	18
		19	20
		Juneteenth DMLI- Of Campus NO CLASSES	First day of summer Summer HS Begins
24	25	26	27

REMINDERS

FRIDAY	SATURDAY	SUNDAY	NOTES
31	SAT 1	2	
9:00 AM - Graduation- National Shrine 7	ACT 8	9	
Flag Day 14	9:00 AM - New Student Placement Exam Uniform Measurements 15	Eid al-Adha begins at sundown Father's Day 16	
21	22	23	
28	29	30	

MONDAY	TUESDAY	WEDNESDAY	THURSDAY
1	2	3	4 <i>Independence Day</i> School/Office Closed
8	9 Summer Band	10	11 Summer Band Summer Prep Session Ends
15 Health Forms Due for ALL Incoming Students	16 Summer Band	17	18 Summer Band Summer HS Ends
22	23 Summer Band	24	25 Summer Band
29	30	31	1

REMINDERS

FRIDAY	SATURDAY	SUNDAY	NOTES
5	6	7 <i>Muharram begins at sundown</i>	
12	13 ACT	14	
19	20	21	
26	27	28	
2	3	4	

AUGUST 2024

★ GOALS

MONDAY	TUESDAY	WEDNESDAY	THURSDAY
29	30	31	1
5	6	7	8
12	13	14	15
19	20	21	22
26	27	28	29

REMINDERS

FRIDAY	SATURDAY	SUNDAY	NOTES
2	3	4	<hr/> <hr/> <hr/> <hr/> <hr/>
9	10	11	<hr/> <hr/> <hr/> <hr/> <hr/>
16	17	18	<hr/> <hr/> <hr/> <hr/> <hr/>
23	24	25	<hr/> <hr/> <hr/> <hr/> <hr/>
30	31	1	<hr/> <hr/> <hr/> <hr/> <hr/>

LANGUAGE ARTS *parts of speech*

NOUN	A WORD THAT NAMES A PERSON, PLACE, THING, QUALITY, ACT, OR FEELING.
-------------	---

Common nouns are general and do not refer to a specific person, location, or object.

→ *Examples:* man, city, tonight, honesty, happiness

Proper nouns are capitalized and refer to a particular person, place, or thing.

→ *Examples:* Reggie, Market Square Arena, Saturday

PRONOUN	A WORD THAT TAKES THE PLACE OF A NOUN.
----------------	--

Nominative Case Pronouns replace the subject of a sentence or clause.

→ *Examples:* *She* took the bus to visit Aunt Jane. We are looking forward to visiting Oregon.

Objective Case Pronouns receive a verb's action or follow a preposition.

→ *Examples:* Please give *me* the papers. Timothy's outstanding service earned *him* the award.

Possessive Case Pronouns show ownership or possession.

→ *Examples:* The cougar escaped from *its* cage. *Their* car slid off the icy road.

VERB	A WORD THAT EXPRESSES ACTION OR A STATE OF BEING. IT ALSO INDICATES THE TIME OF ACTION OR STATE OF BEING. A VERB HAS DIFFERENT FORMS DEPENDING ON ITS NUMBER, PERSON, VOICE, TENSE, AND MOOD.
-------------	---

Number indicates whether a verb is singular or plural. The verb and its subject must agree in number.

→ *Examples:* One dog barks. Two dogs bark.

Person indicates whether the subject of the verb is 1st, 2nd, or 3rd person and whether the subject is singular or plural. Verbs usually have a different form only in *third person singular of the present tense*.

→ *Examples:* *Singular* *Plural*

1st Person: I stop. We stop.

2nd Person: You stop. You stop.

3rd Person: He/She/It stops. They stop.

Voice indicates whether the subject is the doer or the receiver of the action verb.

→ *Examples:* Cathy wrote the letter. (active voice)
The letter was written by Cathy. (passive voice)

Tense indicates when the action or state of being is taking place.

→ *Examples:* We *need* the information now. (present)
Reggie *shot* the ball. (past)
You *will enjoy* the school play. (future)

ADVERB	A WORD THAT DESCRIBES OR MODIFIES A VERB, AN ADJECTIVE, OR ANOTHER ADVERB. AN ADVERB TELLS HOW, WHEN, WHERE, WHY, HOW OFTEN, AND HOW MUCH.
---------------	--

→ *Examples:* The ball rolled *slowly* around the rim. Soccer scores are reported *daily* in the newspaper.

ADJECTIVE	A WORD THAT DESCRIBES OR MODIFIES NOUNS AND PRONOUNS. ADJECTIVES SPECIFY COLOR, SIZE, NUMBER, AND THE LIKE.
------------------	---

→ *Examples:* red, large, three, gigantic, miniature
Adjectives have three forms: **positive**, **comparative**, and **superlative**.

The **positive** form describes a noun or pronoun without comparing it to anything else.

→ *Example:* My apple pie is *good*.

The **comparative** form compares two things.

→ *Example:* Aunt Betty's apple pie is *better* than mine.

The **superlative** form compares three or more things.

→ *Example:* Mom's apple pie is *the best* of all!

PREPOSITION	A WORD (OR GROUP OF WORDS) THAT SHOWS HOW A NOUN OR PRONOUN RELATES TO ANOTHER WORD IN A SENTENCE.
--------------------	--

→ *Examples:* The man walked *into* the gym. The horse leaped *over* the fence.

Their team won the meet *in spite of* several players being injured.

CONJUNCTION	A WORD THAT CONNECTS INDIVIDUAL WORDS OR GROUPS OF WORDS.
--------------------	---

Coordinating conjunctions connect a word to a word, a clause to a clause, or a phrase to a phrase. The sentence elements joined by a coordinating conjunction must be equal. Common coordinating conjunctions are: *and, but, or, nor, for, yet, so*.

Coordinating conjunctions used in pairs are called **correlative conjunctions**. Common correlative conjunctions are: *either, or; neither, nor; not only, but also; both, and; whether, or*.

→ *Examples:* *Both* raccoons *and* squirrels frequently invade our bird feeders.

Neither Mary Ann *nor* Julie will be able to go with you.

Subordinating conjunctions connect and show the relationship between two clauses that are not equally important. Common subordinate conjunctions are: *until, unless, since, where, before, as, if, when, although, after, because, while, as long as, as if, though, whereas*.

→ *Examples:* *Until* you decide to study, your grades won't improve.

If I hadn't already made plans, I would have enjoyed going to the mall with you.

INTERJECTION	A WORD THAT IS USED IN A SENTENCE TO COMMUNICATE STRONG EMOTION OR SURPRISE. PUNCTUATION IS USED TO SEPARATE AN INTERJECTION FROM THE REST OF THE SENTENCE.
---------------------	---

→ *Examples:* *Hooray!* We finally scored a touchdown.

Oh, no! I forgot the picnic basket.

Yes! Her gymnastic routine was perfect.

Ah, we finally get to stop and rest.

LANGUAGE ARTS *capitalization & plurals*

CAPITALIZATION

THE FOLLOWING CHART PROVIDES A QUICK OVERVIEW OF CAPITALIZATION RULES.

All proper nouns → Shannon O'Connor, Orlando, Bill of Rights
All proper adjectives → Kraft cheese, Bounty paper towels, Phillips screwdriver
The first word in every sentence → Her dress is stunning.
Races, languages, nationalities → Asian, French, African-American
Nouns/Pronouns that refer to a supreme being → God, Allah, Yahweh
Days of the week → Sunday, Monday, Tuesday
Formal epithets → Ivan the Terrible
Bodies of water → Amazon River, Lake Huron, Wea Creek
Cities, towns → Houston, Lafayette, Dearborn
Countries → Tippecanoe, Cork
Countries → U.S.A, Mexico, Canada
Continents → Africa, North America
Landforms → Mojave Desert, the Appalachians
Holidays and holy days → Veterans Day, Christmas, Yom Kippur
Months → January, February
Official documents → Emancipation Proclamation
Official titles → President Obama, Mayor Bradley
Periods and events in history → Middle Ages, Renaissance
Planets, heavenly bodies → Mars, Jupiter, Milky Way
Public areas → Yellowstone National Park
Sections of a country or continent → the Northwest, the Middle East
Special events → Battle of Lexington
Streets, roads, highways → Rodeo Drive, Route 66, Interstate 65
Trade names → Honda Accord, Kellogg's Corn Flakes



PLURALS

THE FOLLOWING CHART PROVIDES A QUICK OVERVIEW OF PLURALIZATION RULES.

The plurals of most nouns are formed by adding *s* to the singular.
→ Examples: pie = pies | desk = desks | machine = machines

The plural forms of nouns ending in *s*, *sh*, *x*, *z*, and *ch* are made by adding *es* to the singular.
→ Examples: bus = buses | dish = dishes | fox = foxes | buzz = buzzes | church = churches

The plurals of common nouns that end in *y* preceded by a consonant are formed by changing the *y* to *i* and adding *es*.
→ Examples: fly = flies | copy = copies

The plurals of words that end in *y* preceded by a vowel are formed by adding only *s*.
→ Examples: holiday = holidays | monkey = monkeys

The plurals of words ending in *o* preceded by a vowel are formed by adding *s*.
→ Examples: studio = studios | rodeo = rodeos

The plurals of words ending in *o* preceded by a consonant are formed by adding *s* or *es*.
→ Examples: hero = heroes | banjo = banjos | tomato = tomatoes | piano = pianos

The plurals of nouns ending in *f* or *fe* are formed in one of two ways:
{1} If the *f* sound is still heard in the plural form, simply add *s*.
→ Examples: roof = roofs | chief = chiefs
{2} If the final sound in the plural is a *ve* sound, change the *f* to *ve* and add *s*.
→ Examples: wife = wives | knife = knives

Foreign words and some English words form the plural by taking on an irregular spelling.
→ Examples: crisis = crises | criterion = criteria | goose = geese | ox = oxen

The plurals of symbols, letters, and figures are formed by adding an *s*.
→ Examples: 5 = 5s

The plural of nouns that end in *ful* are formed by adding *s* at the end of the word.
→ Examples: handful = handfuls | pailful = pailfuls | tankful = tankfuls

LANGUAGE ARTS *sentence structure & spelling rules*

SENTENCE STRUCTURE

A **complete sentence** must express a complete thought and must have a subject and a verb.

→ *Example:* He lost the game.

A **sentence fragment** results from a *missing* subject, verb or complete thought.

→ *Example:* Because he was lost.



THERE ARE FOUR TYPES OF SENTENCES: SIMPLE, COMPOUND, COMPLEX, OR COMPOUND-COMPLEX

1

A **simple sentence** consists of one main clause. It expresses one main thought and has one subject and one verb. A simple sentence may contain a compound subject, compound verb, or both.

→ *Examples:* We enjoyed the concert.

Amy and Scott were married yesterday. (compound subject: Amy and Scott)

Ben is leaving work and going home. (compound verb: leaving and going)

2

A **compound sentence** contains two or more main clauses (in italics) connected by a conjunction, a semicolon or a comma with a conjunction.

→ *Examples:* *Collecting fossils is fun, but I think identifying fossils is difficult.* (conjunction)

Andy's suit looks new; it just got back from the cleaners. (semicolon)

Erin came home for Easter, and Courtney went to Florida. (comma/conjunction)

3

A **complex sentence** has one main clause (in italics) and one or more subordinate clauses (underlined).

→ *Examples:* *Dad says that good grades are the result of diligent studying.* (main clause, one independent clause)

Diligent studying is difficult, because I have to work several hours before I can start studying. (main clause, two dependent clauses)

4

A **compound-complex sentence** has two or more main clauses (in italics) and one or more subordinate clauses (underlined).

→ *Examples:* *Because the school bus broke down, the team rode in a van, and the cheerleaders rode in cars.*

Unless my eyes are deceiving me, Kristi is on that runaway horse, and Dale is behind her.

SPELLING RULES

Write *i* before *e* except after *c*, or when sounded like *a* as in *weigh* and *eight*.

→ *Exceptions:* seize, weird, either, leisure, neither

When the *ie/ei* combination is not pronounced *ee*, it is usually spelled *ei*.

→ *Examples:* reign, weigh, neighbor

→ *Exceptions:* friend, view, mischief, fiery

When a multi-syllable word ends in a consonant preceded by one vowel, the accent is on the last syllable and the suffix begins with a vowel — the same rule holds true when you double the final consonant.

→ *Examples:* prefer = preferred | allot = allotted | control = controlling

If a word ends with a silent *e*, drop the *e* before adding a suffix that begins with a vowel.

→ *Examples:* use = using | like = liking | state = stating | love = loving

When the suffix begins with a consonant, do not drop the *e*.

→ *Examples:* use = useful | state = statement | nine = ninety

→ *Exceptions:* argument, judgment, truly, ninth

When *y* is the last letter in a word and the *y* is preceded by a consonant, change the *y* to *i* before adding any suffix except those beginning with *i*.

→ *Examples:* lady = ladies | try = tries | happy = happiness | ply = pliable | fly = flying

LANGUAGE ARTS *punctuation*

PERIOD ●

Use: to end a sentence that makes a statement or that gives a command not used as an exclamation.

→ *Example:* Go to your room, and do not come out until dinner.

Use: after an initial or an abbreviation.

→ *Examples:* Mary J. Jones, Mr., Mrs., Ms.

COMMA ,

Use: to separate words or groups of words in a series.

→ *Example:* I used *worms, minnows, larva, bread balls, and bacon* for bait.

Note: Some stylebooks and teachers require a comma before “and” in a series.

→ *Example:* He *ran, jumped, and yelled.*

Use: to separate an explanatory phrase from the rest of the sentence.

→ *Example:* Escargots, *or snails*, are a delicacy that I relish.

Use: to distinguish items in an address and in a date.

→ *Examples:* John Doe, 290 Main St. Midtown, IN 48105
September 20, 1960

Use: to separate a title or an initial that follows a name.

→ *Example:* Joseph Jones, Ph.D.

QUESTION MARK ?

Use: at the end of a direct or indirect question.

→ *Example:* Did your relatives invite you to visit them this summer?

Use: to punctuate a short question within parentheses.

→ *Example:* I am leaving tomorrow (is that possible?) to visit my cousins in France.

APOSTROPHE ’

Use: to show that one or more letters or numbers have been left out of a word to form a contraction.

→ *Examples:* do not = don’t | I have = I’ve

Use: followed by an *s* is the possessive form of singular nouns.

→ *Example:* I clearly saw this young *man’s* car run that stop sign.

Use: possessive form of plural nouns ending in *s* is usually made by adding just an apostrophe. An apostrophe and *s* must be added to nouns not ending in *s*.

→ *Example:* bosses = bosses’, children’s

COLON :

Use: after words introducing a list, quotation, question, or example.

→ *Example:* Sarah dropped her book bag and out spilled everything: books, pens, pencils, homework, and makeup.

SEMICOLON ;

Use: to join compound sentences that are not connected with a conjunction.

→ *Example:* It’s elementary, my dear Watson; the butler is clearly responsible.

Use: to separate groups of words.

→ *Example:* I packed a toothbrush, deodorant, and perfume; jeans, a raincoat, and sweatshirts; and boots and tennis shoes.

QUOTATION MARKS “ ”

Use: to frame direct quotations in a sentence. Only the exact words quoted are placed within the quotation marks.

→ *Example:* “I don’t know,” she said, “if I will be able to afford the vacation.”

Use: to distinguish a word that is being discussed.

→ *Example:* Mr. Jones suggested I replace the word “always” with “often” in my theme.

Use: to indicate that a word is slang.

→ *Example:* Julie only bought that outfit to show that she’s “with it.”

Use: to punctuate titles of poems, short stories, songs, lectures, course titles, chapters of books, and articles found in magazines, newspapers, and encyclopedias.

→ *Examples:* “You Are My Sunshine,” “Violence in Our Society,” “The Road Not Taken”

SINGLE QUOTATION MARK ’

Use: to punctuate a quotation within a quotation.

→ *Example:* “My favorite song is ‘I’ve Been Working on the Railroad,’” answered little Joey.

EXCLAMATION MARK !

Use: to express strong feeling.

→ *Example:* Help! Help!

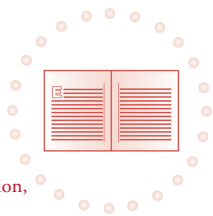

LANGUAGE ARTS *frequently misspelled words*

absence	climbing	equipped	hungry	opportunity	reservoir	trouble
absorb	clothes	escape	identify	opposite	restaurant	truly
accept	colonel	especially	imagine	original	rhyme	two
accidentally	college	etc.	immediate	other	rhythm	unique
accompany	column	everybody	immediately	pageant	ridiculous	until
accuse	commercial	everywhere	immensely	pamphlet	running	unusual
ache	committee	exaggerate	incident	parallel	safety	usually
achieve	completely	exceed	independent	parents	Saturday	vaccinate
acquaintance	concentrate	excellence	Indian	parliament	scent	vacuum
acquire	conscientious	excellent	innocent	particular	schedule	vegetable
affect	conscious	except	instead	passed	scissors	village
afraid	continue	excitement	intelligence	peculiar	search	villain
against	continuous	exciting	intelligent	perform	secret	weather
aggression	convenience	existence	interpret	permanent	secretary	Wednesday
aggressive	convenient	expense	interrupt	persuade	semester	weight
all right	counterfeit	experiment	introduce	phenomenon	sense	weird
a lot	countries	experience	its	philosophy	separate	were
already	courage	familiar	it's	pilot	separation	we're
always	courageous	families	jealous	plain	sergeant	where
amateur	courteous	fascinate	knew	plane	shepherd	whether
ambition	cried	fasten	know	planned	shining	which
among	criticism	fatigue	knowledge	pleasant	sincerely	whole
apology	criticize	favorite	laboratory	poison	soldier	whose
apparent	curiosity	fiction	laid	possess	sophomore	witch
appearance	debt	fictitious	leisure	possession	spaghetti	woman
appreciate	deceive	field	library	possible	speak	women
arctic	decide	finally	lightning	practically	speech	wonderful
argument	definite	first	literature	prairie	sponsor	wreck
article	definitely	forecast	lonely	precede	squirrel	writing
associate	descend	foreign	lose	preferred	stationery	written
athlete	describe	foresee	lying	prejudice	stepping	wrote
attendance	description	forest	magazine	preparation	stopping	yolk
attitude	desert	foretell	magnificent	principal	stories	your
author	dessert	formerly	many	principle	strengthen	you're
awful	destroy	forty	marriage	privilege	stretch	
beautiful	develop	fragile	mathematics	probably	studies	
beauty	dictionary	freight	meant	profession	studying	
because	didn't	friend	medicine	prophecy	succeed	
beginning	difficult	front	millionaire	psychologist	successful	
believe	dinner	fulfill	miniature	psychology	suggest	
benefit	dining	government	minute	pursue	summarize	
bicycle	disappear	governor	mischievous	quantity	summary	
biscuit	disappoint	grabbed	model	quiet	superintendent	
boundary	discipline	grammar	mosquito	quite	suspense	
Britain	discussion	grateful	narrative	raspberry	suspicion	
brilliance	disease	guarantee	necessary	realize	swimming	
brilliant	dissatisfy	guard	neighbor	really	synagogue	
bureau	doctor	guess	nervous	receive	temperament	
business	does	guest	niece	receiving	themselves	
captain	doesn't	handsome	nineteen	recess	there	
career	dropping	happen	ninety	recognize	therefore	
carrying	during	happiest	notice	recommend	they	
cemetery	easier	happily	noticeable	reference	they're	
certain	easiest	happiness	nuisance	referring	thief	
challenge	easily	hear	obedience	rein	thoroughly	
chief	effect	height	occasion	reign	thought	
children	either	here	occur	relative	through	
chocolate	embarrass	history	occurred	relief	tobacco	
chosen	enough	hoping	occurrence	religion	together	
Christian	entertain	hospital	occurring	remember	tomorrow	
cinnamon	envelope	humor	often	repetition	tragedy	
climbed	equipment	humorous	opinion	repellent	tried	



LANGUAGE ARTS *common editing marks*

↑ | *insert a comma*

→ Her husband, Andy, decided to open his own repair business.

↵ | *insert an apostrophe*

→ Mary hadn't planned on a sixth party guest.

“” | *insert quotation marks*

→ The students were required to read the poem "Howl."

∧ | *insert written suggestion*

→ Jean-Pierre said his favorite country to visit was the States.

○ | *use a period*

→ Mark likes scrambled eggs. He does not like hard-boiled eggs.

↵ | *delete*

→ Jim warned me that that magnet might harm my CD.

↔ | *transpose elements*

→ The team could have also placed first in the tournament.

∩ | *close up this space*

→ Milo retreated to his dog house.

| *insert single space*

→ Jeff didn't mind waiting, but he was running out of time.

¶ | *begin new paragraph*

→ "Who's that?" Missy asked. "Her name is Beth," said Brenda.

No ¶ | *no new paragraph*

→ "I'm tired," said Kevin.

"I'd like to go home."

≡ | *capitalize*

→ They traveled to the capitol to meet the vice president.

ℓ | *lowercase*

→ Tim fondly remembers playing football in High School.

sp | *spell out*

→ It was Kim's trip to the U.K.

stet | *stet (let it stand)*

→ I don't like to hurt other people's feelings.

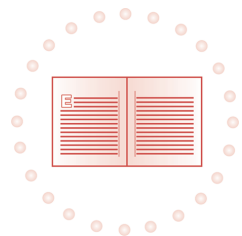

SCIENCE *the solar system*

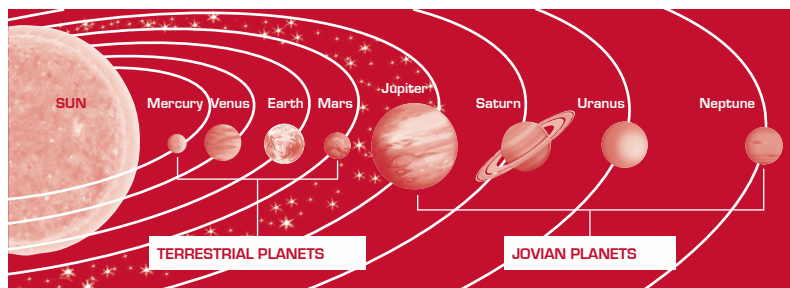

THE SOLAR SYSTEM

Observing the night sky with the naked eye, ancient astronomers noticed moving points of light they called “planets,” which means “wanderers.” Those first planets were named for Roman deities: Mercury, Venus, Mars, Jupiter, and Saturn.

With the invention of the large telescope, astronomers were able to see other planets. These included Uranus in 1781, Neptune in 1846, and Pluto in 1930, which was later redefined as a dwarf planet. Besides planets, thousands of asteroids and comets fill the universe. Most asteroids orbit between Mars and Jupiter. Comets exist beyond Pluto’s orbit.

There are two types of planets. Terrestrial planets, closest to the Sun, have rocky surfaces. These are Mercury, Venus, Earth, and Mars. Those beyond Mars’ orbit – Jupiter, Saturn, Uranus, and Neptune, are called Jovian planets, meaning “gas giants.”

THE SUN

A huge sphere of mostly ionized gas, the sun is the closest star to Earth.

diameter: almost 870,000 miles
temperature: 27 million°F

MERCURY

Named for the Roman Messenger god, Mercury orbits the sun faster than any other planet.

diameter: 3,031 miles
temperature: -280°F to 800°F
mean distance from the sun: 35.98 million miles

VENUS

Named for the Roman goddess of love and beauty, it is the only planet that rotates in the opposite direction of its orbit around the sun.

diameter: 7,521 miles
temperature: 55°F to 846°F
mean distance from the sun: 67.23 million miles

EARTH

Earth is the only planet known to harbor life and the only planet with liquid water on its surface.

diameter: 7,926 miles
temperature: -126°F to 136°F
mean distance from the sun: 92.96 million miles

MARS

Named for the Roman god of war, Mars gets its red coloring from soil rich in iron oxides.

diameter: 4,221 miles
temperature: -225°F to 95°F
mean distance from the sun: 141.61 million miles

JUPITER

The largest planet in our solar system was named for the king of the Roman gods. Its bands of color can be seen with a large telescope.

diameter: 88,846 miles
temperature: -234°F average
mean distance from the sun: 483.80 million miles

SATURN

Named for the Roman god of agriculture, Saturn was the most distant planet known by the ancients. Its rings are comprised of ice particles.

diameter: 74,897 miles
temperature: -288°F
mean distance from the sun: 890.73 million miles

URANUS

Originally named Georgium Sidus in honor of King George III, Uranus was discovered in 1781. It is twice as far from the sun as Saturn.

diameter: 31,763 miles
temperature: -353°F uniform
mean distance from the sun: 1,784.89 million miles

NEPTUNE

Named for the Roman god of the sea, Neptune’s layer of methane gives a blue coloring. Winds tear through its clouds at more than 1,200 mph.

diameter: 30,775 miles
temperature: -391°F
mean distance from the sun: 2,793.12 million miles

DWARF PLANETS

Named for the Roman god of the underworld, Pluto is the coldest, smallest, and outermost planet in our solar system. In 2006, Pluto was reclassified as a dwarf planet. Other dwarf planets are Ceres, Eris, Makemake, Haumea, and Sedna.

SCIENCE *Periodic table of the elements*

GROUP	1 IA ⁺	2 IIA ⁺⁺	Transition Metals										11 IB	12 IIB	13 IIIA	14 IVA	15 VA	16 VIA	17 VIIA	18 VIIIA			
PERIOD	1	2	3	4	5	6	7	8	9	10	11	12	13	14	15	16	17	18					
	1 IA ⁺	2 IIA ⁺⁺	3 IIIB	4 IVB	5 VB	6 VIB	7 VIIB	8 VIII	9 VIII	10 VIII	11 IB	12 IIB	13 IIIA	14 IVA	15 VA	16 VIA	17 VIIA	18 VIIIA					
	1 IA ⁺	2 IIA ⁺⁺	3 IIIB	4 IVB	5 VB	6 VIB	7 VIIB	8 VIII	9 VIII	10 VIII	11 IB	12 IIB	13 IIIA	14 IVA	15 VA	16 VIA	17 VIIA	18 VIIIA					
	1 IA ⁺	2 IIA ⁺⁺	3 IIIB	4 IVB	5 VB	6 VIB	7 VIIB	8 VIII	9 VIII	10 VIII	11 IB	12 IIB	13 IIIA	14 IVA	15 VA	16 VIA	17 VIIA	18 VIIIA					
1	H hydrogen 1.008																	He helium 4.003					
2	Li lithium 6.941(2)	Be beryllium 9.012																B boron 10.81	C carbon 12.01	N nitrogen 14.01	O oxygen 16.00	F fluorine 19.00	Ne neon 20.18
3	Na sodium 22.99	Mg magnesium 24.31	Sc scandium 44.96	Ti titanium 47.87	V vanadium 50.94	Cr chromium 52.00	Mn manganese 54.94	Fe iron 55.85	Co cobalt 58.93	Ni nickel 58.69	Cu copper 63.55	Zn zinc 65.38(2)	Al aluminum 26.98	Si silicon 28.09	P phosphorus 30.97	S sulfur 32.07	Cl chlorine 35.45	Ar argon 39.95					
4	K potassium 39.10	Ca calcium 40.08	Sc scandium 44.96	Ti titanium 47.87	V vanadium 50.94	Cr chromium 52.00	Mn manganese 54.94	Fe iron 55.85	Co cobalt 58.93	Ni nickel 58.69	Cu copper 63.55	Zn zinc 65.38(2)	Ga gallium 69.72	Ge germanium 72.63	As arsenic 74.92	Se selenium 76.97	Br bromine 79.90	Kr krypton 83.80					
5	Rb rubidium 85.47	Sr strontium 87.62	Y yttrium 88.91	Zr zirconium 91.22	Nb niobium 92.91	Mo molybdenum 95.95	Tc technetium (97)	Ru ruthenium 101.1	Rh rhodium 102.9	Pd palladium 106.4	Ag silver 107.9	Cd cadmium 112.4	In indium 114.8	Sn tin 118.7	Sb antimony 121.8	Te tellurium 127.6	I iodine 126.9	Xe xenon 131.3					
6	Cs cesium 132.9	Ba barium 137.3	Lanthanoids	Hf hafnium 178.5	Ta tantalum 180.9	W tungsten 183.8	Re rhenium 186.2	Os osmium 192.2	Ir iridium 192.2	Pt platinum 195.1	Au gold 197.0	Hg mercury 200.6	Tl thallium 204.4	Pb lead 207.2	Bi bismuth 209.0	Po polonium (209)	At astatine (210)	Rn radon (222)					
7	Fr francium (223)	Ra radium (226)	Actinoids	Rf rutherfordium (267)	Db dubnium (268)	Sg seaborgium (269)	Bh bohrium (270)	Hs hassium (269)	Mt meitnerium (277)	Ds darmstadtium (281)	Rg roentgenium (282)	Cn copernicium (285)	Nh nihonium (286)	Fl flerovium (290)	Mc moscovium (290)	Lv livermorium (293)	Ts tennessium (294)	Og oganesson (294)					
				La lanthanum 138.905(47)	Ce cerium 140.116	Pr praseodymium 140.907	Nd neodymium 144.242	Pm promethium (145)	Sm samarium 150.36	Eu europium 151.964	Gd gadolinium 157.25	Tb terbium 158.925(3)	Dy dysprosium 162.500	Ho holmium 164.930(3)	Er erbium 167.259	Tm thulium 168.934(2)	Yb ytterbium 173.054	Lu lutetium 174.9668					
				Ac actinium (227)	Th thorium 232.0377	Pa protactinium 231.03688	U uranium 238.02891	Np neptunium (237)	Pu plutonium (244)	Am americium (243)	Cm curium (247)	Bk berkelium (247)	Cf californium (251)	Es einsteinium (252)	Fm fermium (257)	Md mendelevium (288)	No nobelium (289)	Lr lawrencium (262)					



Group IA (excluding Hydrogen) comprises the alkali metals.
 Group IIA comprises the alkaline-earth metals.
 Group VIIIA comprises the noble gases.

* IUPAC convention: atomic weights; standard atomic weights for these elements are expressed in intervals; see iupac.org for an explanation and a table. ** Numbering system widely used from the mid-20th century system. () Indicates the mass number of the longest-lived isotope.

Source: The International Union of Pure and Applied Chemistry (IUPAC), Encyclopaedia Britannica, and others.

SCIENCE *unit conversions*

ENGLISH TO METRIC CONVERSIONS

<i>To Convert</i> →	<i>Multiply By</i> →	<i>To Find</i> →
AREA		
square inches	6.45	square centimeters
square feet	0.09	square meters
square miles	2.59	square kilometers
acres	0.40	hectares
LENGTH		
inches	2.54	centimeters
feet	0.30	meters
yards	0.91	meters
miles	1.61	kilometers
MASS AND WEIGHT		
ounces	28.35	grams
pounds	0.45	kilograms
pounds-force	4.45	newtons
short tons	0.91	metric tons
VOLUME		
cubic inches	16.39	cubic centimeters
cubic feet	0.03	cubic meters
quarts	0.95	liters
gallons	3.79	liters

METRIC TO ENGLISH CONVERSIONS

<i>To Convert</i> →	<i>Multiply By</i> →	<i>To Find</i> →
AREA		
square centimeters	0.16	square inches
square meters	10.76	square feet
square kilometers	0.39	square miles
hectares	2.47	acres
LENGTH		
centimeters	0.39	inches
meters	3.28	feet
meters	1.09	yards
kilometers	0.62	miles
MASS AND WEIGHT		
grams	0.04	ounces
kilograms	2.20	pounds
metric tons	1.10	short tons
newtons	0.23	pound-force
VOLUME		
cubic centimeters	0.06	cubic inches
cubic meters	35.31	cubic feet
liters	1.06	quarts
liters	0.26	gallons

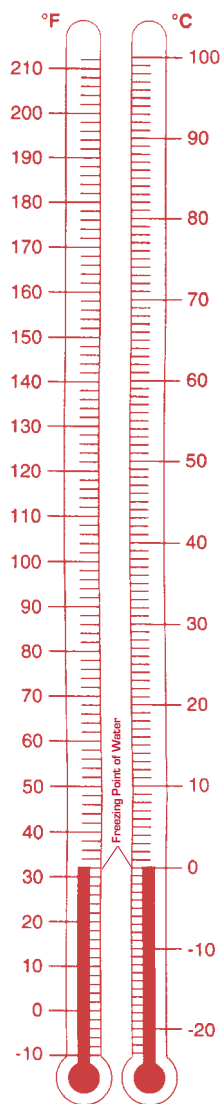

TEMPERATURE

Fahrenheit to Celsius:
 subtract 32,
 then multiply by 5
 and divide by 9.

Celsius to Fahrenheit:
 multiply by 9,
 divide by 5,
 then add 32.

SCIENCE *weights & measures & formulas*



WEIGHTS AND MEASURES

ENGLISH

Area

1 square foot (ft ²)	-----	144 square inches (in ²)
1 square yard (yd ²)	-----	9 square feet
1 acre	-----	43,560 square feet
1 square mile (mi ²)	-----	640 acres

Capacity

1 cup (c)	-----	8 fluid ounces (fl oz)
1 pint (pt)	-----	2 cups
1 quart (qt)	-----	2 pints
1 quart	-----	4 cups
1 gallon (gal)	-----	4 quarts

Length

1 foot (ft)	-----	12 inches (in)
1 yard (yd)	-----	36 inches
1 yard	-----	3 feet
1 mile (mi)	-----	5,280 feet
1 mile	-----	1,760 yards

Time

1 minute (min)	-----	60 seconds (s)
1 hour (h)	-----	60 minutes
1 day (d)	-----	24 hours
1 week (wk)	-----	7 days
1 year (yr)	-----	12 months (mo)
1 year	-----	52 weeks
1 year	-----	365 days
1 century (c)	-----	100 years

Weight

1 pound (lb)	-----	16 ounces (oz)
1 short ton (T)	-----	2,000 pounds

FORMULAS

Perimeter of a rectangle	-----	$P = 2(l+w)$
Perimeter of a square	-----	$P = 4s$
Perimeter of a regular polygon	-----	$P = ns$ (n = number of sides)
Area of a rectangle	-----	$A = lw$
Area of a square	-----	$A = s^2$
Area of a parallelogram	-----	$A = bh$
Area of a triangle	-----	$A = \frac{1}{2}bh$
Area of a trapezoid	-----	$A = \frac{1}{2}h(b_1 + b_2)$
Area of a circle	-----	$A = \pi r^2$
Circumference of a circle	-----	$C = \pi d$, or $2\pi r$
Volume of a rectangular prism	-----	$V = lwh$
Volume of any prism	-----	$V = Bh$
Volume of a cylinder	-----	$V = \pi r^2h$
Volume of a pyramid	-----	$V = \frac{1}{3}Bh$
Volume of a cone	-----	$V = \frac{1}{3}\pi r^2h$
Surface area of a cylinder	-----	$SA = 2\pi r^2 + 2\pi rh$
Pythagorean Theorem	-----	$a^2 + b^2 = c^2$ (sides of a right triangle)

Simple interest----- $I = prt$

Distance----- $d = rt$

METRIC

Area

1 sq centimeter (cm ²)	-----	100 sq millimeters (mm ²)
1 sq meter (m ²)	-----	10,000 sq centimeters
1 hectare (ha)	-----	10,000 square meters
1 sq kilometer (km ²)	-----	1,000,000 sq meters

Capacity

1 milliliter (ml)	-----	.001 liter (L)
1 centiliter (cl)	-----	.01 liter
1 deciliter (dl)	-----	.1 liter
1 dekaliter (dal)	-----	10 liters
1 hectoliter (hl)	-----	100 liters
1 kiloliter (kl)	-----	1,000 liters

Length

1 millimeter (mm)	-----	.001 meter (m)
1 centimeter (cm)	-----	.01 meter
1 decimeter (dm)	-----	.1 meter
1 dekameter (dam)	-----	10 meters
1 hectometer (hm)	-----	100 meters
1 kilometer (km)	-----	1,000 meters

Mass/Weight

1 milligram (mg)	-----	.001 gram (g)
1 centigram (cg)	-----	.01 gram
1 decigram (dg)	-----	.1 gram
1 dekagram (dag)	-----	10 grams
1 hectogram (hg)	-----	100 grams
1 kilogram (kg)	-----	1,000 grams
1 metric ton (t)	-----	1,000 kilograms

FORMULA KEY

A	=	area
b	=	base, length of any side of a plane figure
B	=	area of base
d	=	diameter
h	=	height, perpendicular distance from the furthest point of the figure to the extended base
l	=	length
P	=	perimeter
r	=	radius
s	=	side
sa	=	surface area
V	=	volume
w	=	width

I = interest, p = principal, r = rate, t = time

d = distance, r = rate, t = time

MATHEMATICS *Roman numerals & place value*

ROMAN NUMERALS

IN THE ROMAN NUMBER SYSTEM, NUMERALS ARE REPRESENTED BY 7 CAPITAL LETTERS FROM OUR ALPHABET. THESE LETTERS ARE COMBINED IN DIFFERENT WAYS TO FORM NUMBERS. THE VALUES OF THE LETTERS ARE ADDED TOGETHER, UNLESS A LETTER WITH A LESSER VALUE COMES BEFORE ONE WITH A LARGER VALUE. IN THIS CASE, THE VALUE IS THE DIFFERENCE OF THE TWO LETTER VALUES.

FOLLOWING ARE THE 7 LETTERS AND THEIR VALUES:

I → one
V → five
X → ten
L → fifty
C → one hundred
D → five hundred
M → one thousand

- {1}=I
- {2}=II
- {3}=III
- {4}=IV
- {5}=V
- {6}=VI
- {7}=VII
- {8}=VIII
- {9}=IX
- {10}=X
- {11}=XI
- {12}=XII
- {13}=XIII
- {14}=XIV
- {15}=XV
- {16}=XVI
- {17}=XVII
- {18}=XVIII
- {19}=XIX
- {20}=XX
- {30}=XXX
- {40}=XL
- {50}=L
- {60}=LX
- {70}=LXX
- {80}=LXXX
- {90}=XC
- {100}=C
- {500}=D
- {1000}=M

PLACE VALUE

Hundred Trillions	Ten Trillions	One Trillions	Hundred Billions	Ten Billions	One Billions	Hundred Millions	Ten Millions	One Millions	Hundred Thousands	Ten Thousands	One Thousands	Hundreds	Tens	Ones
1	5	4	3	9	9	7	1	5	4	6	2	1	0	0

Read this number as one hundred fifty-four trillion, three hundred ninety-nine billion, seven hundred fifteen million, four hundred sixty-two thousand, one hundred.

Write this number as 154,399,715,462,100.

Number	Zeros
Thousand	3
Million	6
Billion	9
Trillion	12
Quadrillion	15
Quintillion	18
Sextillion	21
Septillion	24
Octillion	27
Nonillion	30
Decillion	33
Googol	100

NUMBER PREFIXES

uni-	-----	one
bi-	-----	two
tri-	-----	three
quadri-	-----	four
quint-	-----	five
sex-	-----	six
sept-	-----	seven
oct-	-----	eight
non-	-----	nine
deci-	-----	ten

MATHEMATICS *squares & square roots*

SQUARES & SQUARE ROOTS

N	N ²	\sqrt{N}
1	1	1.00
2	4	1.41
3	9	1.73
4	16	2.00
5	25	2.24
6	36	2.45
7	49	2.65
8	64	2.83
9	81	3.00
10	100	3.16
11	121	3.32
12	144	3.46
13	169	3.61
14	196	3.74
15	225	3.87
16	256	4.00
17	289	4.12
18	324	4.24
19	361	4.36
20	400	4.47
21	441	4.58
22	484	4.69
23	529	4.80
24	576	4.90
25	625	5.00
26	676	5.10
27	729	5.20
28	784	5.29
29	841	5.39
30	900	5.48
31	961	5.57
32	1,024	5.66
33	1,089	5.74
34	1,156	5.83
35	1,225	5.92
36	1,296	6.00
37	1,369	6.08
38	1,444	6.16
39	1,521	6.24
40	1,600	6.32
41	1,681	6.40
42	1,764	6.48
43	1,849	6.56
44	1,936	6.63
45	2,025	6.71
46	2,116	6.78
47	2,209	6.86
48	2,304	6.93
49	2,401	7.00
50	2,500	7.07

N	N ²	\sqrt{N}
51	2,601	7.14
52	2,704	7.21
53	2,809	7.28
54	2,916	7.35
55	3,025	7.42
56	3,136	7.48
57	3,249	7.55
58	3,364	7.62
59	3,481	7.68
60	3,600	7.75
61	3,721	7.81
62	3,844	7.87
63	3,969	7.94
64	4,096	8.00
65	4,225	8.06
66	4,356	8.12
67	4,489	8.19
68	4,624	8.25
69	4,761	8.31
70	4,900	8.37
71	5,041	8.43
72	5,184	8.49
73	5,329	8.54
74	5,476	8.60
75	5,625	8.66
76	5,776	8.72
77	5,929	8.77
78	6,084	8.83
79	6,241	8.89
80	6,400	8.94
81	6,561	9.00
82	6,724	9.06
83	6,889	9.11
84	7,056	9.17
85	7,225	9.22
86	7,396	9.27
87	7,569	9.33
88	7,744	9.38
89	7,921	9.43
90	8,100	9.49
91	8,281	9.54
92	8,464	9.59
93	8,649	9.64
94	8,836	9.70
95	9,025	9.75
96	9,216	9.80
97	9,409	9.85
98	9,604	9.90
99	9,801	9.95
100	10,000	10.00

N	N ²	\sqrt{N}
101	10,201	10.05
102	10,404	10.10
103	10,609	10.15
104	10,816	10.20
105	11,025	10.25
106	11,236	10.30
107	11,449	10.34
108	11,664	10.39
109	11,881	10.44
110	12,100	10.49
111	12,321	10.54
112	12,544	10.58
113	12,769	10.63
114	12,996	10.68
115	13,225	10.72
116	13,456	10.77
117	13,689	10.82
118	13,924	10.86
119	14,161	10.91
120	14,400	10.95
121	14,641	11.00
122	14,884	11.05
123	15,129	11.09
124	15,376	11.14
125	15,625	11.18
126	15,876	11.22
127	16,129	11.27
128	16,384	11.31
129	16,641	11.36
130	16,900	11.40
131	17,161	11.45
132	17,424	11.49
133	17,689	11.53
134	17,956	11.58
135	18,225	11.62
136	18,496	11.66
137	18,769	11.70
138	19,044	11.75
139	19,321	11.79
140	19,600	11.83
141	19,881	11.87
142	20,164	11.92
143	20,449	11.96
144	20,736	12.00
145	21,025	12.04
146	21,316	12.08
147	21,609	12.12
148	21,904	12.17
149	22,201	12.21
150	22,500	12.25

MATHEMATICS *fractions & percentages & multiplication table*

FRACTIONS AND PERCENTAGES

1	=	1.0	=	100%
3/4	=	0.75	=	75%
2/3	=	0.667	=	66.7%
1/2	=	0.5	=	50%
1/3	=	0.333	=	33.3%
1/4	=	0.25	=	25%
1/5	=	0.2	=	20%
1/6	=	0.167	=	16.7%
1/7	=	0.142	=	14.2%
1/8	=	0.125	=	12.5%
1/9	=	0.111	=	11.1%
1/10	=	0.1	=	10%
1/11	=	0.091	=	9.1%
1/12	=	0.083	=	8.3%

WORKING WITH FRACTIONS

The top number of a fraction is called the **numerator**.

The bottom number of a fraction is called the **denominator**.



To multiply:

$$\frac{1}{2} \times \frac{3}{4} = \frac{1 \times 3}{2 \times 4} = \frac{3}{8}$$

To divide, multiply the first fraction with the reciprocal of the other:

$$\frac{2}{3} \div \frac{1}{6} = \frac{2}{3} \times \frac{6}{1} = \frac{12}{3} = 4$$



To add or subtract, first find the common denominator:

$$\frac{1}{3} + \frac{2}{5} = \left(\frac{1 \times 5}{3 \times 5}\right) + \left(\frac{2 \times 3}{5 \times 3}\right) = \frac{5}{15} + \frac{6}{15} = \frac{11}{15}$$



MULTIPLICATION TABLE

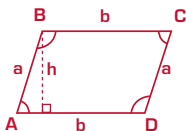

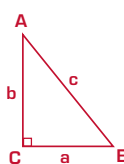
	1	2	3	4	5	6	7	8	9	10	11	12	13	14	15	16	17	18	19	20
1	1	2	3	4	5	6	7	8	9	10	11	12	13	14	15	16	17	18	19	20
2	2	4	6	8	10	12	14	16	18	20	22	24	26	28	30	32	34	36	38	40
3	3	6	9	12	15	18	21	24	27	30	33	36	39	42	45	48	51	54	57	60
4	4	8	12	16	20	24	28	32	36	40	44	48	52	56	60	64	68	72	76	80
5	5	10	15	20	25	30	35	40	45	50	55	60	65	70	75	80	85	90	95	100
6	6	12	18	24	30	36	42	48	54	60	66	72	78	84	90	96	102	108	114	120
7	7	14	21	28	35	42	49	56	63	70	77	84	91	98	105	112	119	126	133	140
8	8	16	24	32	40	48	56	64	72	80	88	96	104	112	120	128	136	144	152	160
9	9	18	27	36	45	54	63	72	81	90	99	108	117	126	135	144	153	162	171	180
10	10	20	30	40	50	60	70	80	90	100	110	120	130	140	150	160	170	180	190	200
11	11	22	33	44	55	66	77	88	99	110	121	132	143	154	165	176	187	198	209	220
12	12	24	36	48	60	72	84	96	108	120	132	144	156	168	180	192	204	216	228	240
13	13	26	39	52	65	78	91	104	117	130	143	156	169	182	195	208	221	234	247	260
14	14	28	42	56	70	84	98	112	126	140	154	168	182	196	210	224	238	252	266	280
15	15	30	45	60	75	90	105	120	135	150	165	180	195	210	225	240	255	270	285	300
16	16	32	48	64	80	96	112	128	144	160	176	192	208	224	240	256	272	288	304	320
17	17	34	51	68	85	102	119	136	153	170	187	204	221	238	255	272	289	306	323	340
18	18	36	54	72	90	108	126	144	162	180	198	216	234	252	270	288	306	324	342	360
19	19	38	57	76	95	114	133	152	171	190	209	228	247	266	285	304	323	342	361	380
20	20	40	60	80	100	120	140	160	180	200	220	240	260	280	300	320	340	360	380	400

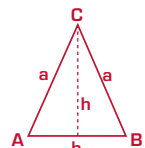
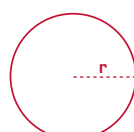
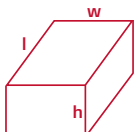
MATHEMATICS *area & volume*

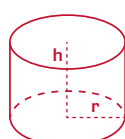
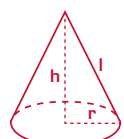

<p>PARALLELOGRAM</p>  <p>Area of ABCD = bh</p>	<p>RECTANGLE</p>  <p>Perimeter = $2(l + h)$ Area = $l \times h$</p>	<p>RIGHT TRIANGLE</p>  <p>Area = $ab/2$ $c^2 = a^2 + b^2$ (Pythagorean Theorem)</p>
---	---	---

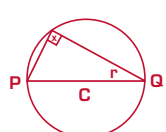
<p>ISOSCELES TRIANGLE</p>  <p>Area = $bh/2$</p>	<p>CIRCLE</p>  <p>Circumference of a circle = $2\pi r$ Area of a circle = πr^2</p>	<p>RECTANGULAR PRISM</p>  <p>Surface area of a prism = $2(wl + lh + wh)$ Volume of a prism = $l \times w \times h$</p>
--	---	--

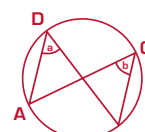
<p>SPHERE</p>  <p>Surface area of a sphere = $4\pi r^2$ Volume of a sphere = $4\pi r^3/3$</p>	<p>CYLINDER</p>  <p>Surface area of a cylinder = $2\pi rh + 2\pi r^2$ Volume of a cylinder = $\pi r^2 h$</p>	<p>CONE</p>  <p>Surface area of a cone = $\pi rl + \pi r^2$ (l = slant height) Volume of a cone = $\pi r^2 h/3$</p>	<p>PYRAMID</p>  <p>Surface area of a pyramid = $B + \text{Lateral Area}$ (Lateral area = sum of triangular faces) Volume of a pyramid = $Bh/3$ (B = area of base)</p>
--	---	---	---

<p>CIRCLE THEOREMS</p>  <p>$\angle x = 90^\circ$ (PQ is the diameter)</p>	 <p>C is the center of the circle</p>	 <p>$\angle a = \angle b$ (Both angles intercept arc AB)</p>
--	--	--

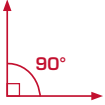
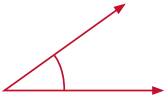
MATHEMATICS *geometric angles & congruence cases*

GEOMETRIC ANGLES			
 <p>A right angle is exactly 90°</p>	 <p>An acute angle is less than 90°</p>	 <p>An obtuse angle is greater than 90°</p>	 <p>A straight angle is exactly 180°</p>

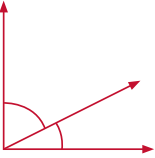
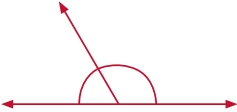
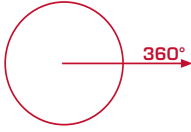
 <p>Complementary angles add up to 90°</p>	 <p>Supplementary angles add up to 180°</p>	 <p>One complete angle of rotation = 360°</p>
---	--	--

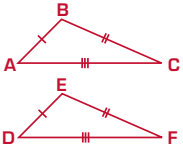
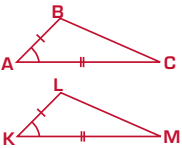
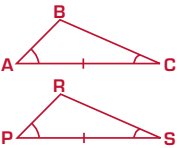
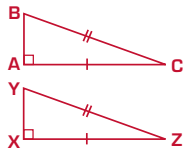
GEOMETRIC CONGRUENCE CASES			
<p>S.S.S. POSTULATE</p>  <p>Side-Side-Side $\triangle ABC \cong \triangle DEF$</p>	<p>S.A.S. POSTULATE</p>  <p>Side-Angle-Side $\triangle ABC \cong \triangle KLM$</p>	<p>A.S.A. POSTULATE</p>  <p>Angle-Side-Angle $\triangle ABC \cong \triangle PRS$</p>	<p>H.S. POSTULATE (RIGHT Δ'S ONLY)</p>  <p>Hypotenuse-side $\triangle ABC \cong \triangle XYZ$</p>

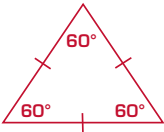
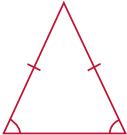
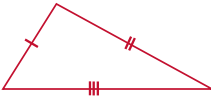
<p>EQUILATERAL TRIANGLE</p>  <p>3 Sides of Equal Length 3 Angles of 60° Each</p>	<p>ISOSCELES TRIANGLE</p>  <p>2 Sides of Equal Length 2 Base Angles are Equal</p>	<p>SCALENE TRIANGLE</p>  <p>3 Unequal Sides 3 Unequal Angles</p>
---	--	---

GEOGRAPHY *world map with longitude & latitude*

