

OXNARD SCHOOL DISTRICT

1051 South "A" Street ● Oxnard, California 93030 ● 805/385-1501



BOARD OF TRUSTEES

Mrs. Veronica Robles-Solis, President
Ms. Monica Madrigal Lopez, Clerk
Mr. Denis O'Leary, Member
Dr. Jesus Vega, Member
Mrs. Debra M. Cordes, Member

ADMINISTRATION

Dr. Cesar Morales
Superintendent
Ms. Janet Penanhoat
Assistant Superintendent,
Business & Fiscal Services
Dr. Jesus Vaca
Assistant Superintendent,
Human Resources & Support Services
Dr. Anabolena DeGenna
Assistant Superintendent,
Educational Services

AGENDA #14
REGULAR BOARD MEETING
Wednesday, April 3, 2019
5:00 p.m. – Study Sessions
Closed Session to Follow
7:00 p.m. - Regular Board Meeting

***NOTE:** In accordance with requirements of the Americans with Disabilities Act and related federal regulations, individuals who require special accommodation, including but not limited to an American Sign Language interpreter, accessible seating or documentation in accessible formats, should contact the Superintendent's office at least two days before the meeting date.

Persons wishing to address the Board of Trustees on any agenda item may do so by completing a **"Speaker Request Form"** and **submitting the form to the Asst. Supt. of Human Resources**. The Speaker should indicate on the card whether they wish to speak during Public Comment or when a specific agenda item is considered.

Note: No new items will be considered after 10:00 p.m. in accordance with Board Bylaws, BB 9323 – Meeting Conduct

www.oxnardsd.org

Broadcasted by Charter Spectrum Channel 20 &
Frontier Communications - Channel 37

Section A
PRELIMINARY

A.1 Call to Order and Roll Call **5:00 PM**

The President of the Board will call the meeting to order. A roll call of the Board will be conducted.

ROLL CALL:

Cordes ___, Vega ___, O’Leary ___, Madrigal Lopez ___, Robles-Solis ___

A.2 Pledge of Allegiance to the Flag

Mr. Greg Brisbine, Principal at Haydock Academy of Arts and Sciences, will introduce Luz Cervantes, 7th grader in Ms. Janet Marks’ class, who will lead the audience in the Pledge of Allegiance.

A.3 District’s Vision and Mission Statements

The District’s Vision and Mission Statements will be read in English by Pedro Garcia, 7th grader in Ms. Ashley Ouimet’s class; then read in Spanish by Kimberli Oregel, 6th grader in Ms. Kimberly Patton’s class.

A.4 Presentation by Haydock Academy of Arts and Sciences

Principal Brisbine will provide a short presentation to the Board regarding Haydock Academy of Arts and Sciences. Following the presentation President Robles-Solis will present a token of appreciation to the students that participated in the Board Meeting.

A.5 Adoption of Agenda (Superintendent)

Moved:
Seconded:
Vote:

ROLL CALL:

Cordes ___, Vega ___, O’Leary ___, Madrigal Lopez ___, Robles-Solis ___

A.6 Recognition of Oxnard School District’s Million Word Readers (DeGenna/Curtis)

The Board of Trustees will recognize students who have read One Million Words. Students will receive a t-shirt that states, “I Read 1,000,000 Words What’s your Superpower.”

A.7 Presentation: Newcomer Program (DeGenna/Batista)

Educational Services team will provide a presentation on the Newcomer Academy, a district program for students new to the county in 3rd-8th grade. The presentation will describe the program and go over the work that has been done over the past two years at McKinna and Frank schools to evaluate, build and strengthen the program.

A.8 Closed Session – Public Participation/Comment (Limit three minutes per person per topic)

Persons wishing to address the Board of Trustees on any agenda item identified in the Closed Session agenda may do so by completing a “Speaker Request Form” and submitting the form to the Assistant Superintendent of Human Resources and Support Services. Public Comment shall be limited to fifteen (15) minutes per subject with a maximum of three (3) minutes per speaker.

The Board will now convene in closed session to consider the items listed under Closed Session.

Note: No new items will be considered after 10:00 p.m. in accordance with Board Bylaws, BB 9323 – Meeting Conduct



Vision:

Empowering All Children to Achieve Excellence

Mission:

Ensure a culturally diverse education for each student in a safe, healthy and supportive environment that prepares students for college and career opportunities.



Visión:

Capacitar a cada alumno para que logre la excelencia académica

Misión:

Asegurar una educación culturalmente diversa para todo el alumnado en un ambiente seguro, saludable y propicio que les prepare para la Universidad y el acceso a oportunidades para desarrollar una carrera profesional.

**Section A
PRELIMINARY**
(continued)

A.9 Closed Session

1. Pursuant to Section 54956.9 of *Government Code*:
 - Conference with Legal Counsel – Anticipated Litigation: 1 case
 - Conference with Legal Counsel – Existing Litigations:
 - Office of Administrative Services OAH Case No.: 2018-12-0803
 - J.R. et. v. Oxnard School District et al. Central District No. CV-04304-JAK-FFM

2. REMOVAL/SUSPENSION/EXPULSION OF A STUDENT (*Education Code 8912; 20 U.S.C. Section 1232g*)
 - Case No. 18-10 (Action Item)
 - Case No. 18-11 (Action Item)

3. Pursuant to Sections 54957.6 and 3549.1 of the *Government Code*:
 - Conference with Labor Negotiator:
 - Agency Negotiators: OSD Assistant Superintendent, Human Resources & Support Services, and Garcia Hernández & Sawhney, LLP
 - Association(s): OEA, OSSA, CSEA;
 - and All Unrepresented Personnel – Administrators, Classified Management, Confidential

4. Pursuant to Section 54957 of the *Government Code* and Section 44943 of the *Education Code* the Board will consider personnel matters, including:
 - a) Public Employee(s) Discipline/Dismissal/Release
 - b) Reassignment, Appointment

A.10 Reconvene to Open Session

7:00 PM

A.11 Report Out of Closed Session

The Board will report on any action taken in closed session or take action on any item considered in closed session, including expulsion of students:

REMOVAL/SUSPENSION/EXPULSION OF STUDENTS
(*Education Code 48912; 20 U.S.C. Section 1232g*)

Case No. 18-10 (Action Item)

Motion: _____, Second: _____

ROLL CALL:

Cordes __, Vega __, O’Leary __, Madrigal Lopez __, Robles-Solis __

Case No. 18-11 (Action Item)

Motion: _____, Second: _____

ROLL CALL:

Cordes __, Vega __, O’Leary __, Madrigal Lopez __, Robles-Solis __

Note: No new items will be considered after 10:00 p.m. in accordance with Board Bylaws, BB 9323 – Meeting Conduct

Section A
PRELIMINARY
(continued)

A.12 Measure D Bond Oversight Committee Annual Report (Penanhoat)

The Assistant Superintendent, Business & Fiscal Services, will introduce Mr. Pedro Chavez, Measure D Bond Oversight Committee chair, who will present the Bond Oversight Committee's second annual report to the Board of Trustees as per Proposition 39 requirements.

A.13 Measure R Bond Oversight Committee Annual Report (Penanhoat)

The Assistant Superintendent, Business & Fiscal Services, will introduce Mr. Crittenden Ward, Measure R Bond Oversight Committee chair, who will present the Bond Oversight Committee's sixth and final annual report to the Board of Trustees as per Proposition 39 requirements.

**Note: No new items will be considered after 10:00 p.m. in accordance with
Board Bylaws, BB 9323 – Meeting Conduct**

Section B
PUBLIC COMMENT/HEARINGS

B.1 Public Comment (3 minutes per speaker)

Members of the public may address the Board on any matter within the Board's jurisdiction at this time or at the time that a specific agenda item is being considered. Comments should be limited to three (3) minutes. Please know this meeting is being video-recorded and televised. The Board particularly invites comments from parents of students in the District.

B.1 Comentarios del Público (3 minutos para cada ponente)

Los miembros del público podrán dirigirse a la Mesa Directiva sobre cualquier asunto que corresponda a la jurisdicción de la Mesa Directiva en este periodo o cuando este punto figure en el orden del día y sea analizado. Los comentarios deben limitarse a tres (3) minutos. Tenga presente que esta reunión está siendo grabada y televisada. La Mesa Directiva invita en particular a los padres y alumnos del distrito a que presenten sus comentarios.

B.2 Adoption of Resolution #18-31 Approving a School Facilities Needs Analysis, Adopting Alternative School Facilities Fees in Compliance with Government Code Sections 65995.5, 65995.6, & 65995.7 and Section 17620 of the Education Code and Making Related Findings and Determinations (Penanhoat)

Current statute authorizes three levels of fees against residential development. The first is the statutory or Level I Fee, which cannot currently exceed \$3.79 per square foot of new residential development for a unified school district. The second is the alternative developer fee commonly referred to as the Level II fee, which is the amount of the local share of a new construction or reconstruction project. The Level III fee is the Level II fee plus the other half that would be contributed from state bond monies. Level III can only be assessed if the State is deemed to be out of funds. The Level II fee may be assessed if the District complies with at least two of the following minimum requirements outlined in Government Code Section 65995.5 and adopts a School Facilities Needs Analysis per the same code section.

Public Comment:
Presentation:
Moved:
Seconded:
Board Discussion:
Vote:

The Oxnard School District has met these requirements as follows: The District retains eligibility for new construction with the State Allocation Board for the School Facilities Program. The District has placed a general obligation bond measure on the ballot within the past four (4) years that has received at least 50 percent plus one of the votes cast for the measure. The District has an indebtedness level in excess of the 15% requirement. Resolution #18-31 adopting alternative developer fees (Level II) on new residential construction is based on the latest School Facilities Needs Analysis that has been developed pursuant to Government Code Section 65995.5, 65995.6, & 65995.7 and Section 17620 of the Education Code.

It is the recommendation of the Assistant Superintendent, Business & Fiscal Services, that the Board of Trustees approve Resolution #18-31 adopting alternative developer fees levied on residential development projects pursuant to Government Code Section 65995.5, 65995.6, & 65995.7 and Section 17620 of the Education Code.

ROLL CALL:

Cordes ____, Vega ____, O'Leary ____, Madrigal Lopez ____, Robles-Solis ____

Note: No new items will be considered after 10:00 p.m. in accordance with Board Bylaws, BB 9323 – Meeting Conduct

Section C CONSENT AGENDA

(All matters specified as Consent Agenda are considered by the Board to be routine and will be acted upon in one motion. There will be no discussion of these items prior to the time the Board votes on the motion unless members of the Board request specific items be discussed and/or removed from the Consent Agenda.)

Notes:
Moved:
Seconded:

ROLL CALL:

Cordes ____, Vega ____, O'Leary ____, Madrigal Lopez ____, Robles-Solis ____

C.1 Agreements

It is recommended that the Board approve the following agreements: Dept/School

Enrichment:

- #18-225 with Oxnard Performing Arts & Convention Center, agreement for the use of facilities for the "Haydock Academy of Arts & Sciences Spring Showcase 2019" which will be held at the Oxnard Performing Arts & Convention Center on Wednesday, June 5, 2019 from 6:00 p.m. – 8:00 p.m., amount not to exceed \$4,248.00, to be paid with targeted school site funds. DeGenna/
Brisbine

C.2 Ratification of Agreements

It is recommended that the Board ratify the following agreements: Dept/School

Special Education:

- #18-216 with Casa Pacifica School, Non-Public School (NPS), ratification to provide services for Student GK041305, for the 2018-2019 school year, including extended school year. The NPS will provide a program of instruction, which is consistent with the pupil's individual educational plan as specified in the individual service agreement, amount not to exceed \$22,325.00, to be paid with Special Education funds. DeGenna/
Sugden
- #18-217 with Casa Pacifica School, Non-Public School (NPS), ratification to provide services for Student KP033105, for the 2018-2019 school year, including extended school year. The NPS will provide a program of instruction, which is consistent with the pupil's individual educational plan as specified in the individual service agreement, amount not to exceed \$53,930.00, to be paid with Special Education funds. DeGenna/
Sugden
- #18-218 with Casa Pacifica School, Non-Public School (NPS), ratification to provide services for Student AT031605, for the 2018-2019 school year, including extended school year. The NPS will provide a program of instruction, which is consistent with the pupil's individual educational plan as specified in the individual service agreement, amount not to exceed \$49,015.00, to be paid with Special Education funds. DeGenna/
Sugden
- #18-222 with Academy for Advancement of Children with Autism Inc., Non-Public School (NPS), ratification to provide services for Student RD042105, for the 2018-2019 school year, including extended school year. The NPS will provide a program of instruction, which is consistent with the pupil's individual educational plan as specified in the individual service agreement, amount not to exceed \$80,610.74, to be paid with Special Education funds. DeGenna/
Sugden

Note: No new items will be considered after 10:00 p.m. in accordance with Board Bylaws, BB 9323 – Meeting Conduct

Section C
CONSENT AGENDA
(continued)

C.2 Ratification of Agreements (continued)

It is recommended that the Board ratify the following agreements: Dept/School

Special Education:

- #18-223 with Ventura County Office of Education (VCOE), Special Circumstances Paraeducator Services, ratify the service agreements with VCOE for the 2018-2019 school year, to provide exceptional services to special education students that consist of support from Special Circumstances Paraeducators (SCP's), including Extended School Year, amount not to exceed \$101,078.00, to be paid with Special Education funds.

DeGenna/
Sugden
- #18-224 with Cynthia Z. Hansen to provide educational therapy and language support services, as well as serve as an Independent Education Evaluator for the Special Education Services Department during the 2018-2019 academic year, amount not to exceed \$20,000.00, to be paid with Special Education funds.

DeGenna/
Sugden

C.3 Ratification of Change Order No. 002 to Construction Services Agreement #17-117 with Bernards Bros. Inc. for the Marshall New Classroom Building Project

It is the recommendation of the Assistant Superintendent, Business & Fiscal Services, and the Director of Facilities, in conjunction with Caldwell Flores Winters, Inc., that the Board of Trustees ratify Change Order No. 002 to Construction Services Agreement #17-117, with Bernards to provide Construction Services related to the Marshall New Classroom Building Project, amount not to exceed \$17,457.00, to be funded from the Master Construct and Implementation Program. Dept/School
Penanhoat/
Fateh/
CFW

C.4 Approval of Contractor Contingency Allocation No. 008 to Construction Services Agreement #17-117 with Bernards Bros. Inc. for the Marshall New Classroom Building Project

It is the recommendation of the Assistant Superintendent, Business & Fiscal Services, and the Director of Facilities, in conjunction with Caldwell Flores Winters, Inc., that the Board of Trustees approve Contractor Contingency Allocation No. 008 to Construction Services Agreement #17-117 with Bernards, for additional items of work related to the Marshall New Classroom Building Project. Contractor Contingency Allocation No. 008 in the amount of \$35,790.00, to be funded from the Master Construct and Implementation Program. The remaining Contractor Contingency balance after Allocation No. 008 will be \$71,899.00. Dept/School
Penanhoat/
Fateh/
CFW

C.5 Ratification of Amendment #1 to Agreement #18-175 – City Impact Inc.

At the Board Meeting of January 16, 2019, the Board of Trustees ratified Agreement #18-175, in the amount of \$90,000.00, with City Impact, Inc. to provide individual and/or group therapy services, and clinical supervision to the Special Education Services Department. Amendment #1 is now required to add Social and Emotional Testing and Assessment Reporting services for the remainder of the fiscal year. The total amount of the agreement will remain the same. Dept/School
DeGenna/
Sugden

It is the recommendation of the Director, Special Education Services, and the Assistant Superintendent, Educational Services, that the Board of Trustees ratify Amendment #1 to Agreement #18-175 with City Impact Inc.

Note: No new items will be considered after 10:00 p.m. in accordance with Board Bylaws, BB 9323 – Meeting Conduct

Section C
CONSENT AGENDA
(continued)

C.6 Ratification of Amendment #1 to Agreement/MOU #18-44 – Tutorific!

<p>At the Board Meeting of August 8, 2018, the Board of Trustees ratified Agreement #18-44, in the amount of \$38,000.00, with Tutorific! to provide additional instruction to students assigned by Special Education Services Department. Amendment #1 in the amount of \$33,000.00, will allow the Special Education Services Department to increase the number of students receiving instruction support through the remainder of the fiscal year, for a new total agreement amount of \$71,000.00. It is the recommendation of the Assistant Superintendent, Educational Services, and the Director, Special Education Services, that the Board of Trustees ratify Amendment #1 to Agreement/MOU #18-44 with Tutorific!, for an amount not to exceed \$33,000.00, to be paid with Special Education funds.</p>	<p>Dept/School DeGenna/ Sugden</p>
--	--

C.7 Ratification of Amendment #2 to Agreement #18-64 – Autism Learning Partners LLC

<p>At the Board Meeting of August 22, 2018, the Board of Trustees ratified Agreement #18-64, in the amount of \$130,000.00, with Autism Learning Partners to work with the Special Education Services Department to provide 1:1 behavior support services. At the Board Meeting of October 24, 2018, the Board of Trustees ratified Amendment #1 to Agreement #18-64, in the amount of \$218,210.00 to cover additional costs for embedded services. Amendment #2 is now required to adjust the total expected costs through the remainder of the fiscal year, in the amount not to exceed \$348,000.00, for a new total agreement amount of \$696,210.00. It is the recommendation of the Director, Special Education Services, and the Assistant Superintendent, Educational Services, that the Board of Trustees ratify Amendment #2 to Agreement #18-64 with Autism Learning Partners LLC, for an amount not to exceed \$348,000.00, to be paid with Special Education funds.</p>	<p>Dept/School DeGenna/ Sugden</p>
---	--

C.8 Approval of Work Authorization Letter #10S to NV5 West Inc., for DSA Inspector of Record Services for the Marshall New Classroom Building Project

<p>At the November 13, 2013, regularly scheduled Board Meeting, the Board of Trustees approved Agreement #13-130 with NV5 West Inc. (formerly known as Nolte-Vertical 5), to provide DSA Inspector of Record Services. The District, in consultation with CFW, recommends issuing WAL #10S to NV5 West Inc., to continue the provision of continuous DSA Inspector of Record Services through the completion of the Marshall New Classroom Building Project.</p>	<p>Dept/School Penanhoat/ Fateh/ CFW</p>
--	--

It is the recommendation of the Assistant Superintendent, Business & Fiscal Services, and the Director of Facilities, in consultation with Caldwell Flores Winters, that the Board of Trustees approve WAL #10S for Master Agreement #13-130 with NV5 West Inc., for a fee in the amount of \$99,560.00, to be funded from the Master Construct and Implementation Program.

Note: No new items will be considered after 10:00 p.m. in accordance with Board Bylaws, BB 9323 – Meeting Conduct

Section C
CONSENT AGENDA

(continued)

C.9 Approval of Work Authorization Letter #10 (“WAL #10”) for Agreement #13-154 with NV5 West Inc., to Provide Environmental Support Services for the McKinna Elementary School Reconstruction Project

<p>At the November 13, 2013, regularly scheduled Board Meeting, the Board of Trustees approved Agreement #13-154 with NV5 West, Inc. to perform environmental sampling and analysis. The District, in consultation with Caldwell Flores Winters (CFW), recommends issuing WAL #10 to NV5 West, Inc. to perform environmental sampling and report. It is the recommendation of the Assistant Superintendent, Business & Fiscal Services, and the Director of Facilities, in consultation with CFW, that the Board of Trustees approve WAL #10 for Master Agreement #13-154 with NV5 West Inc. for a fee in the amount of \$6,105.00, to be funded from the Master Construct and Implementation Program.</p>	<p>Dept/School Penanhoat/ Fateh/ CFW</p>
--	--

C.10 Approval of Notice of Completion, Brekke School Kinder/Flex Project

<p>It is the recommendation of the Assistant Superintendent, Business & Fiscal Services, and the Director of Facilities, in consultation with Caldwell Flores Winters, that the Board of Trustees approve the Notice of Completion and filing of such notice with the County Recorder’s Office, for Construction Services Agreement #17-209 with Viola Inc.</p>	<p>Dept/School Penanhoat/ Fateh/ CFW</p>
---	--

C.11 Approval of Notice of Completion, Harrington Early Child Development Center, Bid #17-01

<p>It is the recommendation of the Assistant Superintendent, Business & Fiscal Services, and the Director of Facilities, in consultation with Caldwell Flores Winters, that the Board of Trustees approve the Notice of Completion and filing of such notice with the County Recorder’s Office, for Bid #17-01, Harrington Early Child Development Center with Ardalan Construction Company Inc.</p>	<p>Dept/School Penanhoat/ Fateh/ CFW</p>
--	--

C.12 Establish/Abolish/Increase/Reduce Hours of Position

<p>It is the recommendation of the Director of Classified Human Resources that the Board of Trustees approve the establishment, decrease and abolishment of the positions as presented.</p>	<p>Dept/School Nair-Villano</p>
---	-------------------------------------

C.13 Personnel Actions

<p>It is the recommendation of the Assistant Superintendent, Human Resources & Support Services and the Director, Classified Human Resources, that the Board of Trustees approve the Personnel Actions, as presented.</p>	<p>Dept/School Vaca/ Nair-Villano</p>
---	---

Note: No new items will be considered after 10:00 p.m. in accordance with Board Bylaws, BB 9323 – Meeting Conduct

Section D
ACTION ITEMS

(Votes of Individual Board Members must be publicly reported.)

D.1 Ratification of Change Order No. 018 to Construction Services Agreement #15-198 with Swinerton Builders to Adjust Costs for the Lemonwood K-8 School Reconstruction Project (Penanhoat/Fateh/CFW)

The Oxnard School District (“District”) Board of Trustees (“Board”) Facilities Implementation Plan first adopted in January 2013, calls for the reconstruction of the Lemonwood K-8 School (“Project”). The Project includes the construction of new school facilities at the existing Lemonwood school site. Change Order No. 018 provides for the Board’s consideration and ratification of eighteen (18) change order proposals.

Public Comment:
Presentation:
Moved:
Seconded:
Board Discussion:
Vote:

Ratification of Change Order No. 18 to Construction Services Agreement #15-98 with Swinerton Builders in the amount of \$109,025.77, to be charged to the Master Construct and Implementation Funds. The Board’s ratification of this increase to the overall project budget constitutes approval of the allocation of \$109,025.77, from the Program Reserve of the Master Construct & Implementation Program, which will be reflected in the next Semi-Annual Update to the Master Construct and Implementation Program Report. It is the recommendation of the Assistant Superintendent, Business & Fiscal Services, and the Director of Facilities, in conjunction with Caldwell Flores Winters, Inc., that the Board of Trustees ratify Change Order No. 018 to Construction Services Agreement #15-198 with Swinerton Builders to provide Construction Services related to the Lemonwood K-8 School Reconstruction Project.

ROLL CALL VOTE:

Cordes __, Vega __, O’Leary __, Madrigal Lopez __, Robles-Solis __

Note: No new items will be considered after 10:00 p.m. in accordance with Board Bylaws, BB 9323 – Meeting Conduct

Section E
APPROVAL OF MINUTES

E.1 Approval of Minutes

It is recommended that the Board approve the minutes of regular board meetings, as submitted:

- March 6, 2019, Regular Board Meeting
- March 20, 2019, Regular Board Meeting

Moved:
Seconded:
Vote:

ROLL CALL VOTE:

Cordes ____, Vega ____, O'Leary ____, Madrigal Lopez ____, Robles-Solis ____

**Note: No new items will be considered after 10:00 p.m. in accordance with
Board Bylaws, BB 9323 – Meeting Conduct**

Section F
BOARD POLICIES

(These are presented for discussion or study.
Action may be taken at the discretion of the Board.)

No minutes will be approved at this meeting.

**Note: No new items will be considered after 10:00 p.m. in accordance with
Board Bylaws, BB 9323 – Meeting Conduct**

**Section G
CONCLUSION**

G.1 Superintendent's Announcements (3 minutes)

A brief report will be presented concerning noteworthy activities of district staff, matters of general interest to the Board, and pertinent and timely state and federal legislation.

Notes:

G.2 Trustees' Announcements (3 minutes each speaker)

The trustees' report is provided for the purpose of making announcements, providing conference and visitation summaries, coordinating meeting dates, identifying board representation on committees, and providing other information of general interest.

Notes:

G.3 ADJOURNMENT

Moved:
Seconded:
Vote:

Time: _____

ROLL CALL VOTE:

Cordes __, Vega __, O'Leary __, Madrigal Lopez __, Robles-Solis __

Note: No new items will be considered after 10:00 p.m. in accordance with Board Bylaws, BB 9323 – Meeting Conduct

OSD BOARD AGENDA ITEM

Name of Contributor: Dr. Ana DeGenna

Date of Meeting: 4/3/19

- A. Preliminary X
Study Session: _____
- B. Hearing: _____
- C. Consent Agenda _____ Agreement Category:
_____ Academic
_____ Enrichment
_____ Special Education
_____ Support Services
_____ Personnel
_____ Legal
_____ Facilities
- D. Action Items _____
- E. Report/Discussion Items (no action) _____
- F. Board Policies 1st Reading _____ 2nd Reading _____

**Recognition of Students - Honoring Oxnard School District's Million Word Readers
(DeGenna/Curtis)**

Students who have read One Million Words will be recognized by the Board of Trustees. Students will receive a t-shirt that states, "I Read 1,000,000 Words What's your Superpower."

FISCAL IMPACT: None

RECOMMENDATION: It is the recommendation of the Assistant Superintendent, Educational Services and the Director of Curriculum, Instruction and Accountability that the Board of Trustees accept this item as presented.

ADDITIONAL MATERIAL: None

OSD BOARD AGENDA ITEM

Name of Contributor: Dr. Ana DeGenna

Date of Meeting: 4/3/19

- Study Session: X
Closed Session:
A-1. Preliminary
A-11. Reports
B. Hearings:
C. Consent Agenda Agreement Category:
 Academic
 Enrichment
 Special Education
 Support Services
 Personnel
 Legal
 Facilities
D. Action Items
F. Board Policies 1st Reading 2nd Reading

Presentation on the Newcomer Program (DeGenna/Batista)

The Newcomer Academy is a district program for students new to the county in 3rd-8th grade. The presentation will describe the program and go over the work that has been done over the past two years at McKinna and Frank to evaluate, build and strengthen the program.

RECOMMENDATION: Informational Only

ADDITIONAL MATERIAL: Power Point

Newcomer Academy:

Accelerating English Acquisition for our Neediest Students

~ One District's Journey for Equity ~

**Dr. Marlene Batista
Fernando Hernandez
Alma Romero**

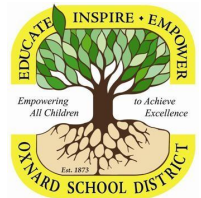

Who are our Newcomer Students?

- U.S. Department of Education Newcomer Toolkit uses newcomer to “refer to any foreign-born students and their families who have recently arrived in the United States.”
- Districts may limit the term to students who have arrived in the last few years, sometimes as little as one year.
- In Oxnard, we identify our Newcomer students as having been in the United States two or less years.
 - Our Academy begins in 3rd grade with a 3rd-5th grade program at Mckinna Elementary and a 6th-8th grade program at R.J. Frank Middle School

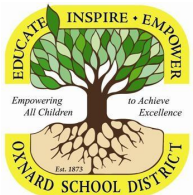

Year 1 (2017-18): Discovery (3-5)

Component	Discovery	Plan
Student Placement	In the past grouping was strategic. Upon transfer of program to present site, student placement was non-strategic.	Based on prior schooling, L1 level curriculum placement, and AR. Based on language levels (3-5 combo in each class).
Grouping	Past practices were not continued upon transfer. Upon transfer to present site grouping was non-strategic.	Students grouped by language level not by grade (in four 3-5 combo classes). Move based on growth in Math/Language.
Movement	Upon transfer to site, movement was based on increase of students.	Movement is determined by assessment-based growth, teacher observation.
Science/Social Studies	No recorded attempts in recent memory for Newcomer Science/Social Studies.	Initiated planning for Newcomer Social Studies and Science.
Math	Grouping by AR Math GE range, however this grouping was inconsistent.	Current grouping by English AR Math GE range (Spanish for some students).
Teachers/Staffing	Upon transfer to current site a lot of turnover. Retention was low.	Looked for teachers with a passion for this demographic.

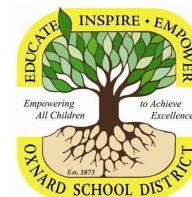

Learn from Experts ~ Year 2

Place Bridge Academy - Denver, CO

- Model program mentioned in US Department of Education Tool Kit
- Visited in October 2016
- Specifically designed ECE-8th grade Newcomer School
- Comprehensive wrap-around services
- Rigorous academic expectations
- Adequate placement and promotion
- Linguistic Options for Families
 - DLI for those who bring Spanish (parent choice)
 - SEI



Davis High School Language Institute- Davis, CA

- Recommended by current principal to visit (VP)
- Visited April 2017 (Spring break)
- Lindsey Bird is the coordinator of the Language Institute- advocate for immigrants
- Students are able to move when ready, not at semester breaks
- Students can take grade level math classes.
- System 44 and Read 180 to accelerate students in reading
- Students are aware of and know their levels and what they need to achieve to move forward
- Students fluent in Spanish take Spanish elective

"We are not a remedial program. We are an acceleration program."



Reflection and Rediscovery

- What worked in year 1 and what had not
- What takeaways did we get from our visits
 - Flexibility of student movement
 - Need for socio-emotional component of program
 - Common assessments to drive instruction and student movement
- What changes needed to happen for year 2

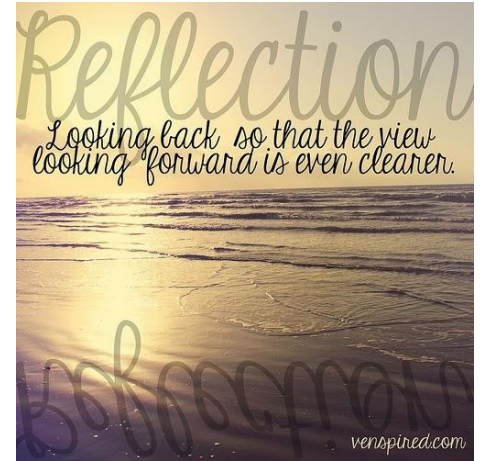

Year 2 (2018-19): The Plan (3-5)

3-5 Combo A (Gandara)	3-5 Combo B (Garcia)	3-5 Combo C (Sharp)	3-5 Combo D (Boulger)
Leveled Math D	Leveled Math C	Leveled Math B	Leveled Math A
PE	PE	PE	PE
ELA – Level A	ELA – Level B	ELA – Level C	ELA – Level D
Lunch	Lunch	Lunch	Lunch
Content Based Social Studies/Science Rotations – A	Content Based Social Studies/Science Rotations – B	Content Based Social Studies/Science Rotations – C	Content Based Social Studies/Science Rotations – D

- Teacher flexibility
- Teaming by language levels and not grades
- Teacher training and TOSA modeling
- Para training
- Support for newcomers in 1st and 2nd grade
- First time explicitly teaching content based newcomer adapted social studies and science

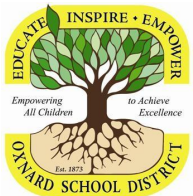

Year 2 Plan (6-8)

Teacher	Advisory	Period 2	Period 3	Period 4	Period 5	Period 6	Period 7	Period 8
NCA 1	ELD Bridge 11	ELD Bridge 11	SS Bridge 11	Prep	Lunch	NCA SS 27	NCA SS 19	NCA SS 22
NCA 2	Group B 22	ELD B 22	ELD B 22	Math NCA 28	GLM 6 13	Lunch	Math 19	Prep
NCA 3	Group A 26	ELD A 26	ELD A 26	SCI NCA 21	SCI NCA 22	Lunch	SC NCA 15	Prep
ELA Teacher	Group C 19	ELD C 19	ELD C 19					
Science								8th Science
Math 7				Math 7	Math 7			
Math 8				Math 8		Math 8		
PE				PE 6-8			PE 6-8	PE 6-8

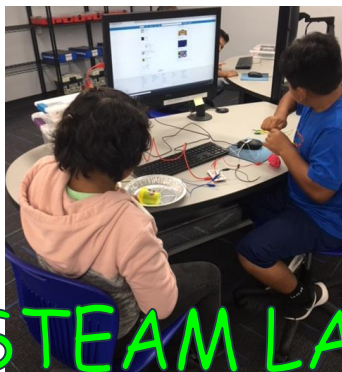

STEAM LAB

- Master Schedule with student needs.
 - Teachers that want to teach.
 - Grouping only in ELD/ELA
 - Bringing class for mainstream
 - Equity for students in math
 - Para training and support
 - Data Chats
 - PLC (Collaboration Time)



Presentations

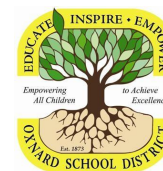

Newcomer Program Development Plan...



Designing Effective Programs for English Learners

W.H.A.T. to do:

W – Welcome them

H – Harness resources

A – Assess assets & needs

T – Teach them

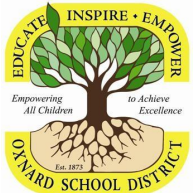

How do we welcome our new students?

W.H.A.T. to do:

W	}	Welcome
H		Harness
A		Assess
T		Teach





Welcoming Students

- Intake Meetings with ORC/Social Worker (in 3-5)
 - TOSA refers to ORC/Social Worker
 - TOSA provides academic intake and discovers academic needs
- Intake Meetings with ORC/TOSA (in 6-8)
 - Discover student and family needs
- Social-Emotional Curriculum/Training
 - Toolbox (3-5)
 - Support for Immigrant and Refugee Students (3-8)
 - Relevant literature w/ strategies

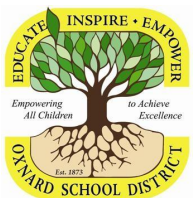

Welcoming Students

- TOSA check-in with students and parents
 - Parent phone calls, home visits
- Strategic grouping/teacher teaming
- Partners/buddies with students within newcomer program
 - Integration/partner activities with Gen Ed students



Parent Workshops

Supporting our Parents

- Workshops
 - Our parents are newcomers too

Four sessions during the year

- Supporting your student at home
- Parent Involvement
- American Schools
- Resource Fair

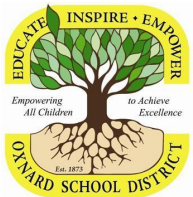

What resources are available for our families, students, and staff?



Resources:

- Professional Development specific to Academy Needs
 - Social/Emotional PD
 - Para Training
 - ELD Standards Training

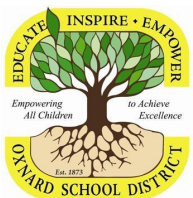

Resources:

- Personnel
 - Parent Liaison
 - School Counselors
 - Outreach Specialists
 - Connect families to community resources
 - District Support
 - District Mixteco Translators
 - Translators for additional languages
 - Paraeducators in classrooms
 - Social worker at elementary level

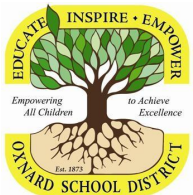

How do we monitor academic progress?

W.H.A.T. to do: 

W } Welcome
H } Harness
A } Assess
T } Teach

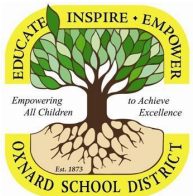

Monitoring 6-8

- Vertical Articulation across programs
- PLCs
- Creative Schedule/Structures - Teacher Teaming
- School Site TOSA

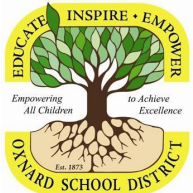

Monitoring 3-5

- Intake assessments and data gathering around students
 - Academic background, socio-emotional needs, parental education and available support
- PLCs
- Teacher Teaming
- School Site TOSA

Monitoring 3-5

- Progress monitoring
 - Developing and finalizing our assessments for 3-5 Newcomer Academy
 - Multiple assessments that focus on four domains
 - One-on-one assessments
 - Reading foundations, reading comprehension, listening and speaking

How do we design instruction of language, literacy and content to best meet the needs of our newcomer students?

W.H.A.T. to do:

W	}	Welcome
H		Harness
A		Assess
T		Teach



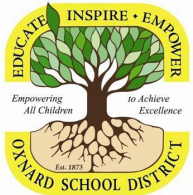

Trimester Moves 6-8

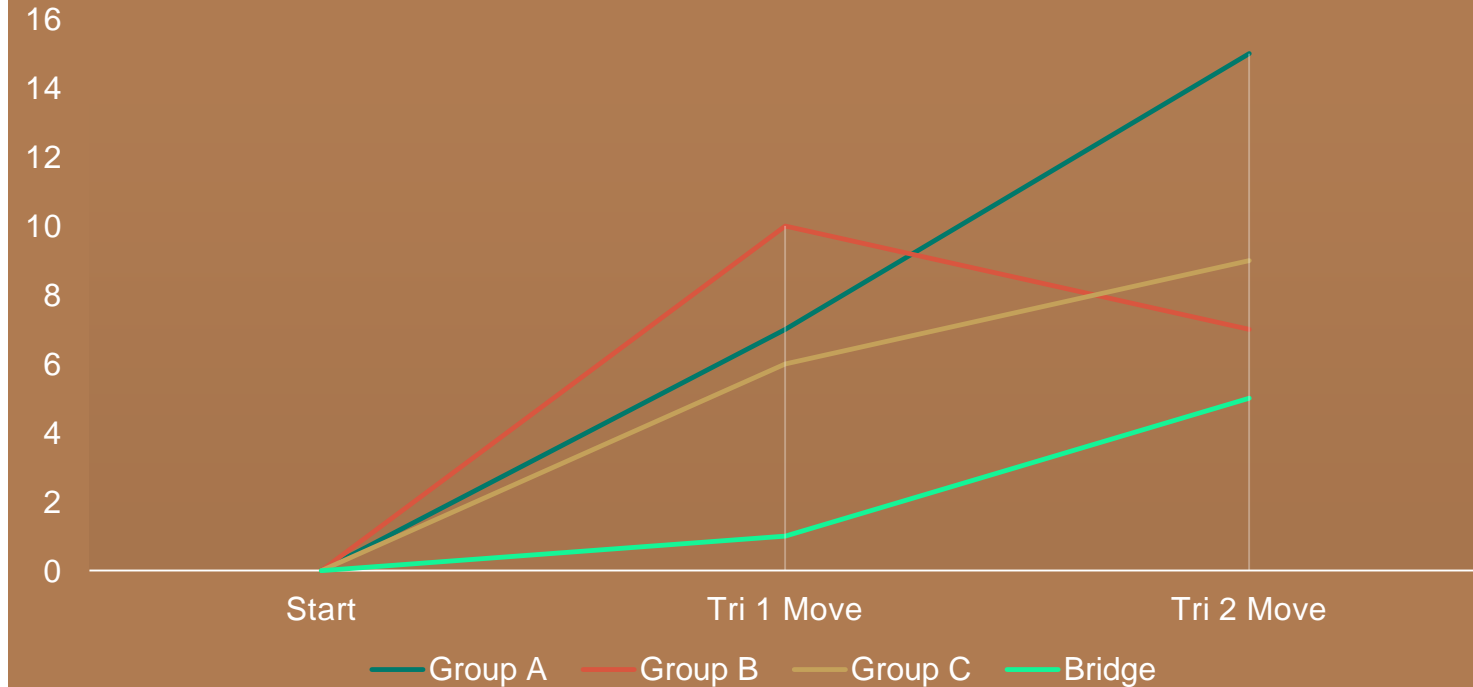

13 of the 22 6th grade students who transferred from McKinna were mainstreamed within the 1st trimester

Enrollement 6-8

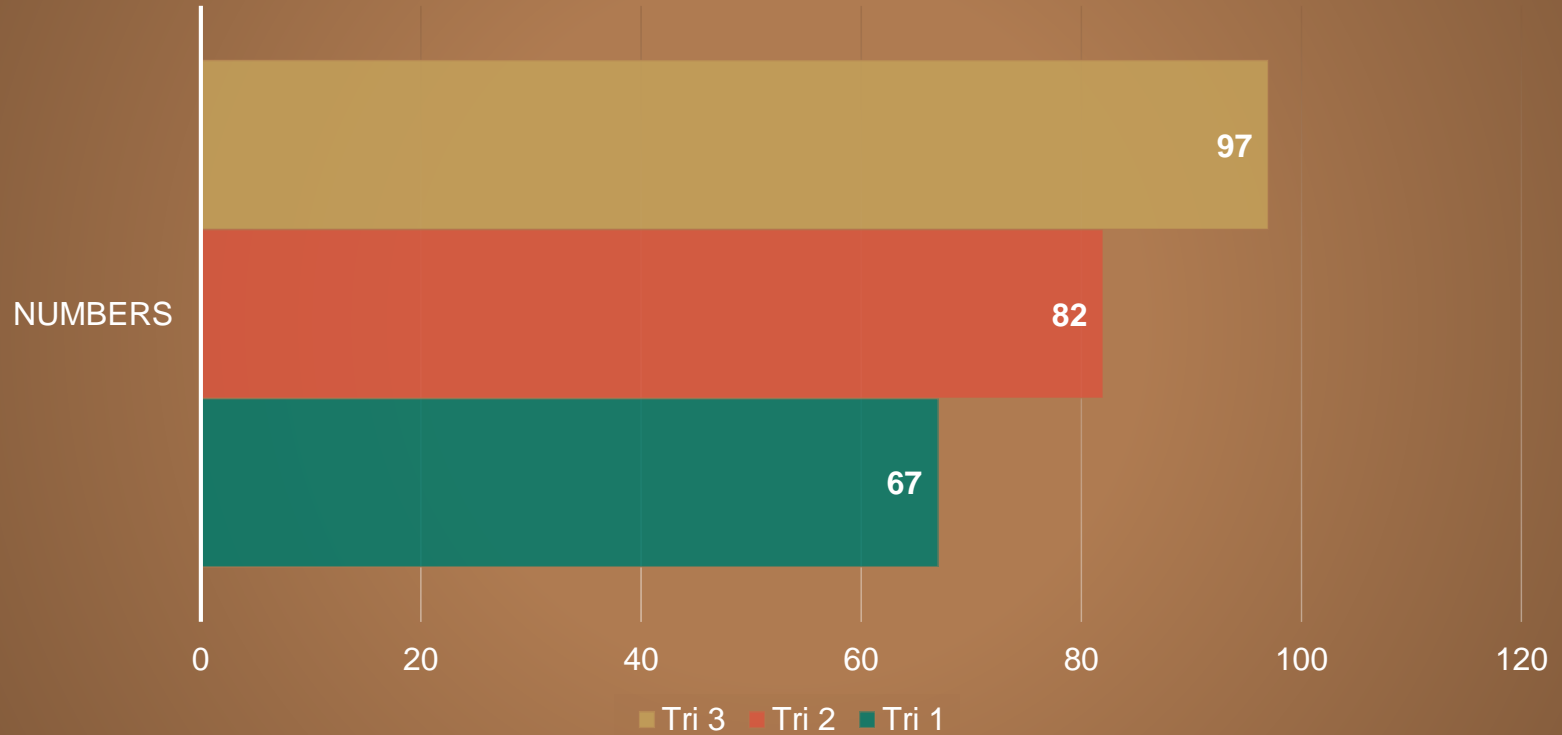

Highly Trained Teachers

- Professional Development specific to Academy Needs
 - Social/Emotional PD
 - FOSS Science Training
 - CAPIT Training
 - ELD Standards Training

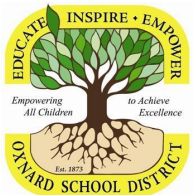

Base Curriculum for Newcomers 3-5

- REACH - NG Connect
 - In The USA
 - Reach Into Phonics
 - Reach Levels A-D
- Oxford Picture Dictionary For Kids
- Wonders for Newcomers
- My Math
- Pearson Language Central for Math

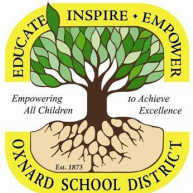
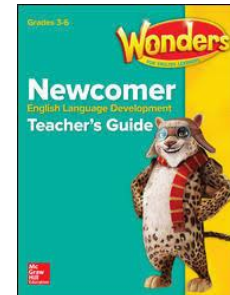
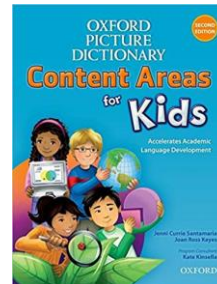

Instruction, Literacy, and Content

- Strategic grouping based on student academic backgrounds/levels. Instruction is tailored to student needs
 - A
 - B
 - C
 - D

Base Curriculum for Newcomers 6-8

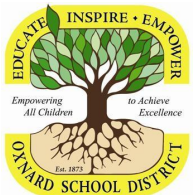
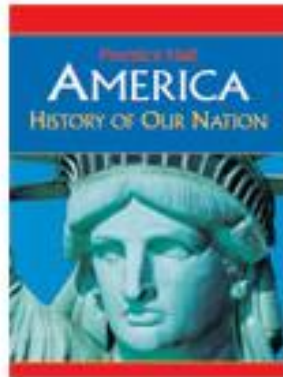
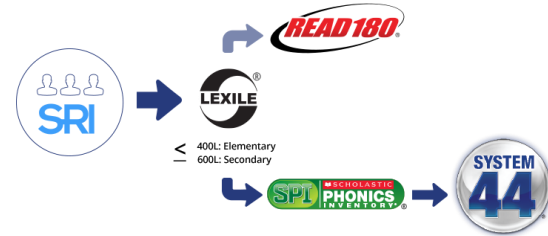

Findings ~ What Worked?

- District/Leadership Support with flexibility

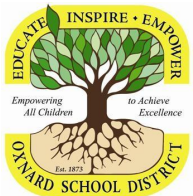
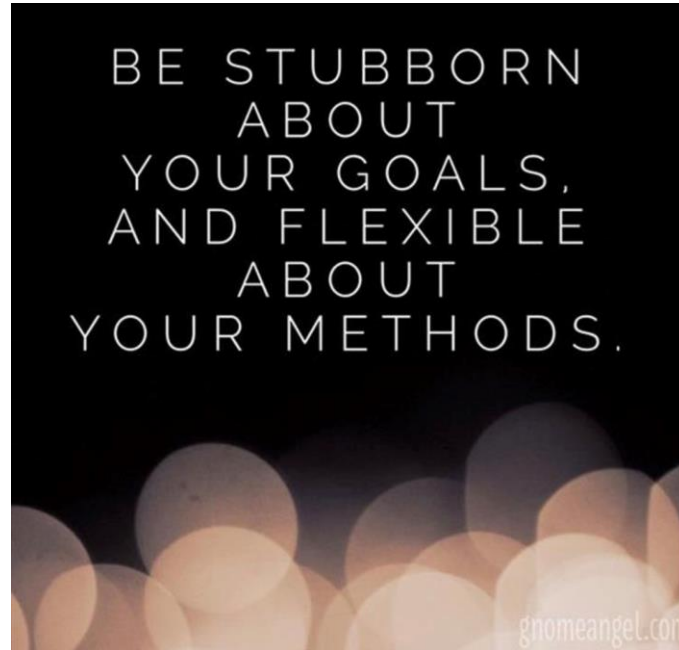

Next Steps

- Write a Procedures Manual for Academy
- Survey of teachers, students and parents
- Further collect data

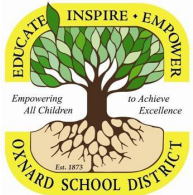

Next Steps

- **Yearly self-reflection ~ growth mindset**

Important achievements
require a clear focus, all-out
effort, and a bottomless trunk
full of strategies. Plus allies in
learning.

Carol Dweck

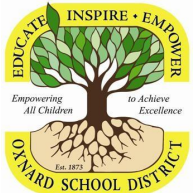

Investigation Phase: Researching Best Practices and Resources

- **US Department Of Education Newcomer Tool Kit:**
<https://www2.ed.gov/about/offices/list/oela/newcomers-toolkit/ncomertoolkit.pdf>
- **Helping Newcomer Students Succeed in Secondary Schools and Beyond (Center For Applied Linguistics):**
https://www.carnegie.org/media/filer_public/ff/fd/ffda48e-4211-44c5-b4ef-86e8b50929d6/ccny_report_2012_helping.pdf
- **WIDA Focus On - SLIFE: Students with Limited or Formal Education:**
<http://www.ride.ri.gov/Portals/0/Uploads/Documents/OSCAS/English-Learner-Pages/EL-Toolkit/XI-Newcomer-WIDA-Focus-on-SLIFE-Final.pdf>
- **BELIEF:**
https://rcoe.learning.powerschool.com/mmccabe/b.e.l.i.e.f/cms_page/view/3618561



Questions??



BOARD AGENDA ITEM

Name of Contributor: Janet Penanhoat

Date of Meeting: April 3, 2019

- STUDY SESSION _____
- CLOSED SESSION _____
- SECTION A-I: PRELIMINARY _____
- SECTION A-II: REPORTS X
- SECTION B: HEARINGS _____
- SECTION C: CONSENT AGENDA _____

Agreement Category:

- _____ Academic
- _____ Enrichment
- _____ Special Education
- _____ Support Services
- _____ Personnel
- _____ Legal
- _____ Facilities

SECTION D: ACTION _____

SECTION F: BOARD POLICIES 1ST Reading _____ 2nd Reading _____

MEASURE D BOND OVERSIGHT COMMITTEE ANNUAL REPORT (Penanhoat)

The Assistant Superintendent, Business & Fiscal Services, will introduce Mr. Pedro Chavez, Measure D Bond Oversight Committee chair, who will present the Bond Oversight Committee’s second annual report to the Board of Trustees as per Proposition 39 requirements.

FISCAL IMPACT

None.

RECOMMENDATION

None – Information only.

ADDITIONAL MATERIAL

Attached: 2018 Measure D Bond Oversight Committee Annual Report (2 pages)

Financial Information

Measure D Bond Sales

Total Authorization: \$142.5 million
 Series A—\$81 million March 2017
 Series B—\$14 million March 2018
 Remaining Authorization : \$47.5 million

Measure D Bond Oversight Committee

2018 Meeting Dates

January 29, 2018
 April 30, 2018
 July 16, 2018
 October 22, 2018

Annual Financial & Performance Audit

The integrity of Measure D funds are audited annually by an independent accounting firm. For fiscal year ending June 30, 2018, the District's auditor was Nigro and Nigro, A Professional Accountancy Corporation. As described in the independent firm's audit report, it is the firm's opinion that the financial statements present fairly, in all material respects, the financial position of the Measure D General Obligation Bond Building Fund as of June 30, 2018, and the changes in financial position thereof for the fiscal year then ended in accordance with accounting principles generally accepted in the United States of America. In regards to the performance audit, the firm's opinion was that the District complied with compliance requirements for the Measure D General Obligation Bond proceeds. The Bond Oversight Committee has reviewed the independent auditor's reports, and together with their other activities, believe that Measure D funds have been spent in accordance with the language of the voter approved Measure and in a manner consistent with applicable State law.

Measure D General Obligation Bond Building Fund Statement of Revenues, Expenditures, and Changes in Fund Balance For the Fiscal Year Ended June 30, 2018

	Measure "D" Building Fund
REVENUES	
Interest earnings	\$ 998,707
Total Revenues	998,707
EXPENDITURES	
Current:	
Books and supplies	1,309
Services and other operating expenditures	776,812
Capital outlay	16,348,800
Debt Service:	
Issuance costs	302,907
Total Expenditures	17,429,828
Excess (Deficiency) of Revenues Over (Under) Expenditures	(16,431,121)
OTHER FINANCING SOURCES (USES)	
Proceeds from bond issuances	13,996,626
Net Change in Fund Balance	(2,434,495)
Fund Balance, July 1, 2017	80,523,583
Fund Balance, June 30, 2018	\$ 78,089,088

**There were no audit findings in
 2017-18**

Measure D Bond Oversight Committee

2018 Annual Report to the Community

OXNARD SCHOOL DISTRICT
 February 2019



McKinna Elementary School Construction Progress (Left) and Groundbreaking (Right)

The **Measure D Bond Oversight Committee (Committee)** has been established to actively review and report on the expenditure of voter-approved bonds, receive and review copies of annual performance and financial audits, and present an annual written report.

Measure D is a \$142.5 million General Obligation (G.O.) bond authorization approved by voters in November 2016. All projects are consistent with the project list provided to voters by the District's Board of Trustees. The District has issued approximately \$95 million in Measure D bonds, leaving approximately \$47.5 in remaining authorization.

Measure D efforts are well underway including the start of construction for the reconstructed McKinna elementary school. Designs are currently under review by the Division of State Architect (DSA) for the Rose Avenue Reconstruction Project and New Seabridge School Project, with DSA approval for Seabridge anticipated by late October/early November 2018. New Kindergarten/Flex classroom projects are under construction and are anticipated to be completed by November 2018 at McAuliffe, Ritchen, and Brekke and by February 2019 at Ramona. Land acquisition and California Environmental Quality Act (CEQA) efforts are completed for the Doris Avenue and Patterson site as well as the start of the LAFCO annexation process.

This report shares project progress and financial information. On behalf of the Committee, I hope that the Oxnard community will find this report informative.

Sincerely,
 Pedro A. Chavez, Chair
 Measure D Bond Oversight Committee

Measure D Bond Oversight Committee

- Pedro A. Chavez, Chair
- Business Organization Representative
- Lisa Latimer, Vice Chair
- Community at Large Representative
- William Belcher
- Community at Large Representative
- Socorro Castro
- Senior Citizens Organization Member
- John Jay
- Bona-fide Taxpayers Organization Member
- Michelle Larios
- Parent/Guardian of Enrolled Child
- Will Ray Jr.
- PTA/Parent Representative
- The Committee meets at least quarterly. Each member of the committee is appointed by the District's Board of Trustees for a two year term of service.
- Committee minutes and information on bond funded projects are available on the Bond Oversight Committee page located on the Measure D website:
- www.oxnardbondprojects.org
- **Oxnard School District**
- Dr. Cesar Morales
- Superintendent
- **Board of Trustees**
- Debra M. Cordes, President
- Ernest Morrison, Clerk
- Denis O'Leary, Trustee
- Veronica Robles-Solis, Trustee
- Monica Madrigal Lopez, Trustee

Overview

The District has adopted a Master Construct and Implementation Program which is funded through the use of Measure D and Measure R bond programs and other local funding, including developer fees, Mello Roos funds, and capital program balances. The Master Construct and Implementation Program also seeks to maximize State aid reimbursements for modernization and construction of school facilities as State funds become available.

Measure D projects are well underway including the construction start of the reconstructed McKinna K-5 elementary school, near Division of State Architect (DSA) approval of the Seabridge K-5 school, DSA submittal of the reconstructed Rose Avenue K-5 School, and the construction of kindergarten/flex classroom buildings at four elementary schools. The new elementary and middle school site at Doris Avenue and Patterson Road has been purchased, the Final Environmental Impact Report completed and approved, and the LAFCo annexation process initiated. Measure D may also be used to fund additional projects as established in the Master Construct and Implementation Program as permitted by the Measure D bond project list.

McKinna Elementary School Reconstruction

The McKinna Elementary School Reconstruction project includes the construction of a new two-story classroom building, library, administration space, multipurpose room, playfields, hard courts, and support spaces. The new facility will be accessed from a new parking and drop-off provided at "N" Street. Once completed, the older structures will be demolished and new playfields and remaining support facilities will be constructed in their place. The project is currently under construction and anticipated to be completed by December 2019.

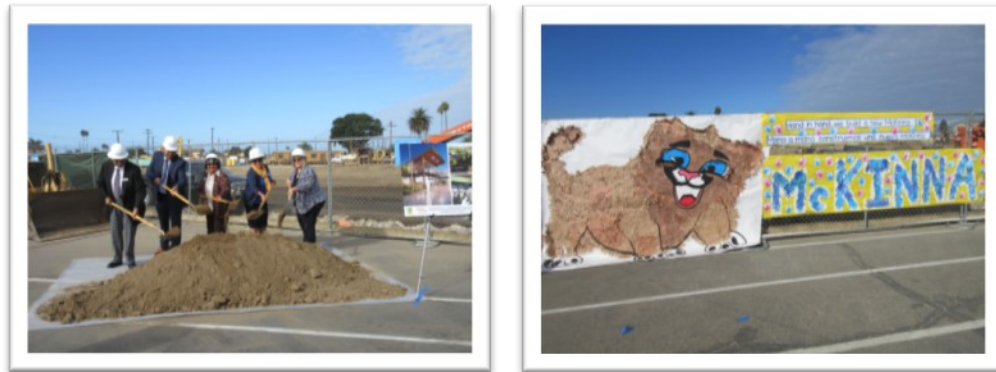

Reconstruction of McKinna School - Groundbreaking Event October 2018

Rose Avenue School Reconstruction

New facilities planned for the Rose Avenue Reconstruction project include a two-story classroom building, library, administration space, multipurpose room, playfields, hard courts, and support spaces. The new facilities will be located in the south half of the site along La Puerta Avenue, where playfields currently exist. Upon completion, the north half of the site is to be demolished and replaced with new playgrounds, hard courts, and play fields. The project is currently under review by the Division of the State Architect (DSA).



Reconstruction of Rose Avenue School—Design Renderings by IBI Group

New Seabridge K-5 School

The New Seabridge K-5 School consists of a new elementary school north of Oxnard's Seabridge neighborhood along Wooley Road. The site was purchased in 2013. New facilities include a two-story classroom building, library, administration space, multipurpose room, playfields, hard courts, and support spaces. Approval from the Division of State Architect is anticipated for late October/early November 2018.



New Seabridge K-5 School—Design Renderings by Flewelling and Moody

New Kindergarten/Flex Classroom Facilities

Four new modular kindergarten/flex classroom projects are under construction at McAuliffe, Ritchen, Brekke, and Ramona Elementary Schools. Each project includes the construction of two modular Kindergarten/Flex classrooms along with support spaces. These rooms may support TK/Kindergarten needs as well as potential Special Education program uses. The facilities at McAuliffe, Ritchen, and Brekke are anticipated to be completed by November 2018 with Ramona to be completed by February 2019.



Sample New Kindergarten/Flex Classroom Building - Brekke Elementary School October 2018

Doris/Patterson New Construction

The Doris/Patterson site has been planned to accommodate the construction of a new grade 6-8 middle school for 1200 students and a grade K-5 elementary school for 700 students, both per State standards. Land acquisition efforts were completed in April 2018. In March 2018, the District completed the final Environmental Impact Report (EIR) for the project and filed the required notices of completion for the Final EIR, pursuant to the California Environmental Quality Act. The project requires annexation into the City of Oxnard, pursuant to Ventura Local Agency Formation Commission (LAFCo) approval of several changes of organization, collectively called reorganization. The LAFCo application process has been initiated in cooperation with the District's consultants. Upon completion of the LAFCo process, efforts will be launched to select a design team for the projects.

BOARD AGENDA ITEM

Name of Contributor: Janet Penanhoat

Date of Meeting: April 3, 2019

STUDY SESSION _____
CLOSED SESSION _____
SECTION A-I: PRELIMINARY _____
SECTION A-II: REPORTS X
SECTION B: HEARINGS _____
SECTION C: CONSENT AGENDA _____

Agreement Category:

_____ Academic
_____ Enrichment
_____ Special Education
_____ Support Services
_____ Personnel
_____ Legal
_____ Facilities

SECTION D: ACTION _____

SECTION F: BOARD POLICIES 1ST Reading _____ 2nd Reading _____

MEASURE R BOND OVERSIGHT COMMITTEE ANNUAL REPORT (Penanhoat)

The Assistant Superintendent, Business & Fiscal Services, will introduce Mr. Crittenden Ward, Measure R Bond Oversight Committee chair, who will present the Bond Oversight Committee's sixth and final annual report to the Board of Trustees as per Proposition 39 requirements.

FISCAL IMPACT

None.

RECOMMENDATION

None – Information only.

ADDITIONAL MATERIAL

Attached: 2018 Measure R Bond Oversight Committee Annual Report (2 pages)

Financial Information

Measure R Bond Sales

Total Authorization: \$90 million
 Series A—\$18.39 million December 2012
 Series B—\$25.5 million May 2013
 Series C – \$15.75 million October 2014
 Series D - \$30.36 million July 2015
 Total Bond Sales: \$90 million

Measure R Bond Oversight Committee

2018 Meeting Dates

January 22, 2018
 April 23, 2018
 July 23, 2018 (No quorum)
 October 15, 2018

Annual Financial & Performance Audit

The integrity of Measure R funds are audited annually by an independent accounting firm. For fiscal year ending June 30, 2018, the District's auditor was Nigro and Nigro, A Professional Accountancy Corporation. As described in the independent firm's audit report, it is the firm's opinion that the financial statements present fairly, in all material respects, the financial position of the Measure R General Obligation Bond Building Fund as of June 30, 2018, and the changes in financial position thereof for the fiscal year then ended in accordance with accounting principles generally accepted in the United States of America. In regards to the performance audit, the firm's opinion was that the District complied with compliance requirements for the Measure R General Obligation Bond proceeds. The Bond Oversight Committee has reviewed the independent auditor's reports, and together with their other activities, believe that Measure R funds have been spent in accordance with the language of the voter approved Measure and in a manner consistent with applicable State law.

Measure R General Obligation Bond Building Fund

Statement of Revenues, Expenditures, and Changes in Fund Balance For the Fiscal Year Ended June 30, 2018

	Measure "R" Building Fund
REVENUES	
Interest earnings	\$ 190,680
Other local revenue	4,214
Total Revenues	194,894
EXPENDITURES	
Current:	
Materials and supplies	1,307,196
Services and other operating expenditures	1,347,268
Capital outlay	23,098,857
Total Expenditures	25,753,321
Excess (Deficiency) of Revenues Over (Under) Expenditures	(25,558,427)
Fund Balance, July 1, 2017	25,558,427
Fund Balance, June 30, 2018	\$ -

**There were no audit findings in
 2017-18**

Measure R Bond Oversight Committee

2018 Annual Report to the Community

OXNARD SCHOOL DISTRICT
 February 2019



New Lemonwood Elementary School Classroom Building

The **Measure R Bond Oversight Committee (Committee)** is pleased to present its sixth and final report to the community on the progress of Measure R projects. This report provides a summary of program progress and financial information.

Approved by voters in November 2012, Measure R is a \$90 million General Obligation (G.O.) bond authorization. Measure R has enabled the acquisition of the Seabridge K-5 elementary school site, the completion of kindergarten and science lab upgrades to 22 classrooms across eight school sites, and the opening of the new K-5 campus and completion of a new child development center/kindergarten annex at Harrington Elementary School. Projects underway include continued reconstruction efforts for the new Lemonwood K-8 school (Phase 2) and new Elm K-5 campus, and a new 12 classroom building at Marshall elementary school.

The District has issued all of the Measure R bond authorization and has expended all of its Measure R funds. The Committee has continued to meet for the purpose of actively monitoring all Measure R projects and expenditures, providing proper oversight, controls, and accountability to ensure that Measure R funds were used as they were intended, and making regular reports to the community at-large on the progress of Measure R projects.

Pursuant to State law and since all Measure R proceeds have been expended, this will serve as the Committee's final report for Measure R. The Committee expresses its gratitude for the opportunity to serve the community.

Sincerely,
 Crittenden Ward, Chair
 Measure R Bond Oversight Committee

- **Measure R Bond Oversight Committee**
- Crittenden Ward, Chair
- *Community at Large Representative*
- Jessica Vargas, Vice Chair
- *PTA/SSC Parent Representative*
- Karen Hill Scott
- *Community at Large Representative*
- Nancy Lindholm
- *Business Organization Representative*
- Alyssa Maria
- *Parent/Guardian of Enrolled Child*
- Charles McLaughlin
- *Bona-fide Taxpayers Organization Member*
- Jeannette Padilla/Robin Freeman
- *Senior Citizens Organization Member*
- *The Committee meets at least quarterly. Each member of the committee is appointed by the District's Board of Trustees for a two year term of service.*
- *Committee minutes and information on bond funded projects are available on the Bond Oversight Committee page located on the Measure R website:*
- www.oxnardbondprojects.org
- **Oxnard School District**
- Dr. Cesar Morales
- *Superintendent*
- **Board of Trustees**
- Debra M. Cordes, President
- Ernest Morrison, Clerk
- Denis O'Leary, Trustee
- Veronica Robles-Solis, Trustee
- Monica Madrigal Lopez, Trustee

Overview of Measure R Projects

Construction Progress

Overview

The District has adopted a Master Construct and Implementation Program which is funded through the use of Measure R and Measure D bond programs and other local funding, including developer fees, Mello Roos funds, and capital program balances. The Master Construct and Implementation Program also seeks to maximize State aid reimbursements for modernization and construction of school facilities as State funds become available.

Completed Measure R facility efforts include the acquisition of the Seabridge K-5 elementary school site, kindergarten and science lab upgrades to 22 classrooms across eight school sites, the opening of the new Harrington K-5 campus, and a new child development center/kindergarten annex at Harrington Elementary School. Projects underway include continued reconstruction efforts for the new Lemonwood K-8 school (Phase 2) and new Elm K-5 campus, and a new 12 classroom building at Marshall elementary school.

Lemonwood Reconstruction

The Lemonwood Reconstruction project includes a new school to accommodate 900 students by State standards in grades K-8. The project also includes specified support facilities, administration areas, media center, food service, multipurpose room, physical education spaces, and restrooms. Construction commenced in May 2016 and is planned to occur over two construction phases to minimize disruptions to the ongoing educational program.

The first phase of construction is complete and includes the main classroom and multipurpose buildings. This phase of work achieved substantial completion for the new classroom building in January 2018, and for the multi-purpose building in February 2018. Occupation of the new classroom building and multi-purpose building by students and staff occurred as planned in February 2018. In March 2018, the District conducted a "Soft Opening" event celebrating the completion of the first phase of work. The event was well received by the school site and the community. Construction is underway for the second phase and will include new kindergarten and administration buildings, to be completed by April 2019.



New Lemonwood Elementary School Soft Opening Celebration - March 2018

Elm Reconstruction

The Elm Reconstruction project includes new two-story classrooms, kindergarten classrooms, and multipurpose and administration facilities. The new school is designed to serve up to 600 students per State standards in grades K-5. Construction began in February 2017 and is planned to be completed over two construction phases, with the first phase of construction scheduled to be completed by December 2018 and the second phase by June 2019.



Elm Construction Progress -October 2018

Marshall New Classroom Building

A new two-story classroom building is currently under construction at Marshall Elementary School. The building is designed to meet interim 6-8 grade level capacity needs until a new middle school is constructed and to provide Marshall with additional classrooms and a long-term K-8 educational program option. Upon completion, the added building will provide 12 additional permanent classrooms. This building has been carefully designed to match the existing campus on the outside while providing modern, flexible and agile learning environments on the inside. Construction commenced in September 2017 and substantial completion is forecasted for December 2018.



New Marshall Classroom Building Construction Progress - October 2018

Harrington Early Childhood Development Center/Kindergarten Annex

The Harrington Early Child Development Center/Kindergarten Annex project includes the renovation of three buildings of the original Harrington school to provide flexible classroom facilities to serve preschool or kindergarten/transitional kindergarten programs. The project included providing four classrooms that meet preschool and kindergarten requirements and improved playground areas. Construction commenced in September 2017 and was completed in August 2018.

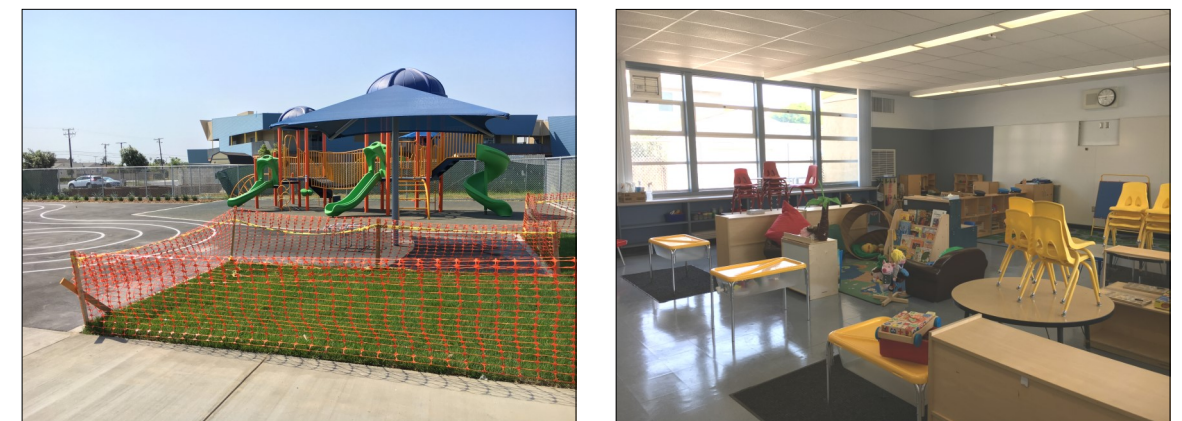

Harrington Child Development Center/Kindergarten Annex

BOARD AGENDA ITEM

Name of Contributor: Janet Penanhoat

Date of Meeting: 4/3/19

STUDY SESSION _____
CLOSED SESSION _____
SECTION A-1: PRELIMINARY _____
SECTION A-II: REPORTS _____
SECTION B: HEARINGS X
SECTION C: CONSENT AGENDA _____

_____ Agreement Category:
_____ Academic
_____ Enrichment
_____ Special Education
_____ Support Services
_____ Personnel
_____ Legal
_____ Facilities

SECTION D: ACTION _____
SECTION F: BOARD POLICIES 1ST Reading _____ 2nd Reading _____

Adoption of Resolution #18-31 Approving a School Facilities Needs Analysis, Adopting Alternative School Facilities Fees in Compliance with Government Code Sections 65995.5, 65995.6, & 65995.7 and Section 17620 of the Education Code and Making Related Findings and Determinations (Penanhoat)

Current statute authorizes three levels of fees against residential development. The first is the statutory or Level 1 Fee, which cannot currently exceed \$3.79 per square foot of new residential development for a unified school district. The second is the alternative developer fee commonly referred to as the Level II fee, which is the amount of the local share of a new construction or reconstruction project. The Level III fee is the Level II fee plus the other half that would be contributed from state bond monies. Level III can only be assessed if the State is deemed to be out of funds. The Level II fee may be assessed if the District complies with at least two of the following minimum requirements outlined in Government Code Section 65995.5 and adopts a School Facilities Needs Analysis per the same code section.

The Oxnard School District has met these requirements as follows:

1. The District retains eligibility for new construction with the State Allocation Board for the School Facilities Program.
2. The District has placed a general obligation bond measure on the ballot within the past four (4) years that has received at least 50 percent plus one (1) of the votes cast for the measure.
3. The District has an indebtedness level in excess of the 15% requirement.
4. Resolution #18-31 adopting alternative developer fees (Level II) on new residential

construction is based on the latest School Facilities Needs Analysis that has been developed pursuant to Government Code Section 65995.5, 65995.6, & 65995.7 and Section 17620 of the Education Code.

FISCAL IMPACT

New residential development projects will be assessed a fee of \$4.09 per square foot of assessable space for new residential construction. For the period of one year after the adoption of this Resolution, the Level II fee will supersede any Level I residential developer fees that may have been adopted. This Resolution does not affect the Level I commercial fees.

RECOMMENDATION

It is the recommendation of the Assistant Superintendent, Business & Fiscal Services, that the Board of Trustees approve Resolution #18-31 adopting alternative developer fees levied on residential development projects pursuant to Government Code Section 65995.5, 65995.6, & 65995.7 and Section 17620 of the Education Code.

ADDITIONAL MATERIAL

Attached: Resolution #18-31 (10 pages)
 Oxnard School District 2019 School Facilities Needs Analysis (77 pages)

OSD BOARD AGENDA ITEM

Name of Contributor: Dr. Anabolena DeGenna

Date of Meeting: 4/3/19

- Study Session:** _____
Closed Session _____
- A-1. **Preliminary** _____
A-II. **Reports** _____
B. **Hearings** _____
C. **Consent Agenda** _____
- Agreement Category:**
____ Academic
 X **Enrichment**
____ **Special Education**
____ **Support Services**
____ **Personnel**
____ **Legal**
____ **Facilities**
- D. **Action Items** _____
F. **Board Policies** 1st Reading _____ 2nd Reading _____

Approval of Agreement #18-225 – Oxnard Performing Arts & Convention Center (DeGenna/Brisbine)

This agreement is for the “Haydock Academy of Arts & Sciences Spring Showcase 2019” which will be held at the PAC on Wednesday, June 5, 2019 from 6:00pm – 8:00pm.

FISCAL IMPACT:

Not to Exceed \$4,248.00 – School Site Funds-Targeted

RECOMMENDATION:

It is the recommendation of the Principal, Haydock Academy of Arts & Sciences, and the Assistant Superintendent, Educational Services, that the Board of Trustees approve Agreement #18-225 with the Oxnard Performing Arts & Convention Center.

ADDITIONAL MATERIALS:

Attached: Agreement #18-225, Oxnard Performing Arts & Convention Center (10 Pages)

PERFORMING ARTS AND CONVENTION CENTER
 LICENSE AGREEMENT - THEATER

This Performing Arts and Convention Center License Agreement (“Agreement”) is made and entered into in the County of Ventura, State of California, this 3rd day of April 2019, by and between the Oxnard Performing Arts Center Corporation, a nonprofit corporation, (“PACC”), and “Haydock Academy of Arts and Sciences”, (“Licensee”).

WHEREAS, PACC operates and maintains the Oxnard Performing Arts and Convention Center for use by various organizations, entities and persons for conventions, trade shows, exhibitions, theatrical performances, meetings, concerts, and similar activities; and

WHEREAS, PACC hereby desires to make the Oxnard Performing Arts and Convention Center Theater available to Licensee for a license fee.

NOW, THEREFORE, PACC and Licensee agree as follows:

1. Facilities Provided

a. PACC hereby authorizes Licensee to use the Oxnard Performing Arts and Convention Center Theater (“Theater”) as more particularly LOCATED AT 800 Hobson Way, Oxnard, California 93030.

b. PACC agrees to provide Licensee with standard furnishings and equipment including heating, air conditioning, general lighting, use of the stage, dressing rooms and orchestra pit.

c. PACC agrees to provide Theater for Licensee’s use including the following services: Necessary custodial services, utilities, general supervision by Stage Manager, one public address set-up with three microphones, and one lighting set-up.

d. PACC agrees to provide Licensee with the following special equipment/supplies and personnel:

(1) Equipment/Supplies	
(a) Stage Lighting	\$ <u>330.00</u>
(b) Pro Audio System	<u>180.00</u>
(c) 4 Wireless Microphones	<u>260.00</u>
(d) Stage Playback Monitors	<u>45.00</u>
(e) Panasonic DLP Projector	<u>130.00</u>
(2) Personnel	
(a) Stage Technicians	\$ <u>1,288.00</u>
(b) House Manager	<u>200.00</u>
(c) 2 Ushers	<u>140.00</u>
(d) Box Office	<u>N/A</u>

2. Coordination of Use

All uses of Theater are to be coordinated with the PACC Executive Director or designee (“Executive Director”) and shall be under the general direction of Executive Director.

3. License Period

PACC agrees that Licensee may use the entire complex on the following dates, during the hours specified below:

Moving In: Wednesday, June 5, 2019 1:00 PM
Moving Out: Wednesday, June 5, 2019 9:00 PM
Program: Wednesday, June 5, 2019 6:00 PM

4. Reservation Fee

Licensee agrees to pay PACC a non-refundable reservation fee in the amount of \$ _____ to Executive Director. The PACC shall credit the reservation fee toward payment of other fees and charges owed by Licensee.

5. License Fee

a. Licensee agrees to pay PACC the following fees for the use of Theater and the use of any special equipment/supplies and personnel:

(1) License Fee	\$ <u>1,650.00</u>
(2) Equipment/Supplies	<u>945.00</u>
(3) Personnel	<u>1,628.00</u>
(4) Insurance	<u>OWN</u>
(5) Non-Refundable Processing Fee	<u>25.00</u>
TOTAL	\$ <u>4,248.00</u>

b. Licensee agrees to pay any addendum charges for additional services or equipment related to Licensee’s use of the Theater. An estimate of any addendum charges is attached hereto as Exhibit A and incorporated herein by this reference. The actual addendum charges will be determined after the PACC has actually provided the services or equipment.

6. Gross Receipts Fees

If the license fee is based on gross receipts, gross receipts shall mean the total sums, exclusive of taxes, collected from patrons by Licensee.

7. No Free Passes

Licensee may not issue free passes or admissions to Licensee's event without the written consent of Executive Director.

8. Maintenance of Records

Licensee shall maintain true and accurate records of receipts of admissions and concession sales, if any, and shall satisfactorily and thoroughly account for the receipt thereof. Executive Director shall have the right to inspect such records.

9. Proposed Event

The event to be presented by Licensee shall consist of "Haydock Academy Showcase". Licensee's use of Theater shall be limited to the event as described herein.

10. Fee for Admission

a. PACC agrees that Licensee may charge admission during the proposed use of Theater by Licensee.

b. (1) Licensee agrees to include in the price of admission to Theater a Facility Restoration Fee of \$1.00 per ticket for tickets priced \$10.00 to \$14.99 and \$2.00 per ticket for tickets priced \$15.00 or more. The Facility Restoration Fee is for the exclusive benefit of the PACC Facility Restoration Fund.

(2) All advertising for Licensee's event at Theater shall include the following statement: "A Facility Restoration Fee shall be added to each ticket."

(3) Licensee agrees, that for general admission events without tickets for sale, Licensee shall pay a \$.50 per admission Facility Restoration Fee as an addendum charge.

11. Removal of Property

a. Licensee agrees to remove from Theater, on or before **8:00 AM** on the **6th** day of **June 2019**, all property, goods, equipment, supplies and effects belonging to Licensee or caused by Licensee to be brought to Theater.

b. If any such property is not removed by the above stated time, Licensee authorizes Executive Director to sell the property in any manner Executive Director deems appropriate and to hold the proceeds from the sale for Licensee, less any costs incurred by PACC.

c. Executive Director may, in his or her sole discretion, store, or cause to be stored, any such property not removed by the above stated time. Licensee agrees to pay PACC

all costs associated with such storage.

12. PACC Not Liable For Licensee's Property

In the receipt, handling, care or custody of property of any kind shipped or otherwise delivered to Theater either prior to, during, or subsequent to the use of Theater by Licensee, PACC and its officers, agents and employees shall act solely for the accommodations of Licensee; and neither PACC nor its officers, agents or employees shall be liable for any loss, damage or injury to such property.

13. Handling of Funds

a. In the handling, control, custody and keeping of funds whether the funds are received through the PACC box office or otherwise, Licensee agrees that PACC is acting for the accommodation of Licensee, and as to such funds PACC shall not be liable to Licensee or to any other person for any loss, theft or defalcation thereof, whether such loss, theft, or defalcation is caused or done by officers, employees or agents of the PACC.

b. No PACC officer, employee or agent shall be liable for any loss, theft or defalcation of such funds unless PACC willfully causes or permits the same or unless the loss, theft or defalcation was caused by the gross negligence of an officer, employee or agent of PACC.

14. Prop Entrance

Licensee shall bring all prop articles, fixtures, materials, displays into or out of Theater only at such entrances as may be designated by Executive Director.

15. Care of Theater

Licensee will not drive any nails, screws, tacks, pins, or other objects into the floors, walls, ceilings, partitions, doors, door or window casings, or woodwork of Theater and will not in any manner change or move any of the fixtures of Theater except as may be authorized by Executive Director.

16. Electrical Work and Plans

Licensee shall file with Executive Director a description of all electrical work and a plan or description of any structures, or decorations to be erected for the event. Licensee will not construct or erect such electrical work, structures, or decorations without prior written approval by Executive Director.

17. Animals Prohibited

Licensee agrees that no domestic or wild animals or birds shall be taken into, or kept in or about Theater, or any part thereof, without the written consent of Executive Director.

18. Signs Require Permission

Licensee agrees that no signs or advertisements shall be placed in, on, or about Theater without the consent of Executive Director.

19. Televising Requires Permission

No event presented in Theater shall be broadcast, televised, or in any manner recorded for reproduction without the written consent of Executive Director.

20. Conduct of Persons

a. Licensee agrees to comply with all ordinances, statutes, rules and regulations applicable to the conduct or operation of the activities of Licensee herein permitted. Licensee shall provide adequate security protection to maintain order in and about Theater.

b. Licensee shall be solely responsible for the orderly conduct of all persons using Theater by invitation, either expressed or implied, during all times covered by this Agreement.

c. Licensee shall not permit intoxicated persons or alcoholic beverages at Theater by invitation, either expressed or implied, during all times covered by this Agreement.

d. PACC reserves the right to eject or cause to be ejected from Theater any person making loud, personal, impertinent, profane or slanderous remarks so as to disrupt an event at Theater.

21. Control of Theater

a. The keys to Theater shall at all times be in the possession and control of Executive Director. PACC shall lock and unlock the entrance and exits of Theater at such times as may be required for Licensee's use. Licensee, at its own expense, must at all times place proper security at all entrances and exits when the same are unlocked.

b. PACC and all duly authorized representatives of PACC shall have the right to enter Theater and all parts thereof at all times.

22. Lost Articles

PACC or its representatives shall have the sole right to collect and have the custody of articles left in Theater by persons attending any event. Licensee or any person in Licensee's employ shall not collect nor interfere with the collection or custody of such articles.

23. Flammable Materials

Licensee may not use flammable materials such as bunting, tissue paper, crepe paper, for decorations. All materials used for decorative purposes must be treated with flame proofing and approved by the Fire Marshall.

24. Entertainment Standards

Licensee shall not conduct any event in Theater and Complex that is illegal or obscene.

25. Concession Sales by PACC

PACC reserves the sole right:

a. To contract for the sale of programs, librettos, periodicals, books, magazines, newspapers, soft drinks, flowers, tobacco, candies, food, novelties or any related merchandise commonly sold or dispensed in Theater and Complex; opera glasses, cushions, and other articles; and photographs.

b. To operate the parking lots, and check rooms; provided, however, that Executive Director may, in writing, authorize Licensee to do any of the aforesaid upon such terms as Executive Director deems proper under the circumstances, subject to the provisions of any existing contracts.

26. Sales by Licensee

a. Licensee may sell from the Theater only those items approved in writing by Executive Director. Licensee shall provide Executive Director with an accounting of such sales and shall pay PACC fifteen percent (15%) of the gross amount of sales, exclusive of sales tax.

b. Licensee shall not serve food or beverages for the event except by agreement with caterers approved by Executive Director.

27. Use of PACC Box Office

Licensee agrees that PACC shall be responsible for ordering and selling tickets sold at the PACC box office at fees so designated on the Box Office Agreement attached hereto as Exhibit B. If a computerized ticket system is used, Licensee agrees to use PACC's designated ticket agency.

28. Complimentary Tickets

a. Licensee agrees not to issue more than fifty (50) complimentary tickets to the Licensee's event without the written consent of Executive Director.

29. Copyright

Licensee agrees to assume all costs and obligations arising from the use of patented and/or copyrighted materials, equipment, devices, processes or dramatic rights furnished or used or incorporated in the event. Licensee agrees to obtain and pay for all appropriate BMI, ASCAP, and SESAC licenses for the event.

30. Assignment

Licensee shall not assign this Agreement in whole or in part, nor may any right hereunder granted to Licensee be granted in turn to any other person without the written consent of Executive Director.

31. Occupancy Interruption

a. In case Theater or any part thereof shall be destroyed or damaged by fire or any other cause, or if any other casualty or unforeseen occurrence, including strikes, labor disputes, war, or acts of military authorities, shall render the fulfillment of this Agreement difficult or impossible of performance, this Agreement shall be immediately terminated.

b. PACC shall not in any such case be held liable or responsible to Licensee for any damage caused by termination of this Agreement. PACC shall be relieved from any further liability by reason of this Agreement, and no claims or compensation or damage shall be made against the PACC by Licensee. Any fee for the unused portion of the Agreement shall under such circumstances be refunded to Licensee.

32. Indemnity

a. To the fullest extent permitted by law, Licensee shall (1) immediately defend; (2) indemnify; and (3) hold harmless PACC, the City of Oxnard, its City Council, each member thereof, and its directors, officers, and employees (the “**Indemnified Party**”) from and against all liabilities regardless of nature, type, or cause, arising out of or resulting from or in connection with Licensee’s performance of this Agreement or Licensee’s failure to comply with any of its obligations contained in this Agreement. Liabilities subject to the duties to defend and indemnify include, without limitation, all claims, losses, damages, penalties, fines, and judgments; associated investigation and administrative expenses; defense costs, including but not limited to reasonable attorneys’ fees; court costs; and costs of alternative dispute resolution. Licensee’s obligation to indemnify applies unless it is adjudicated that any of the liabilities covered by this Section are the result of the sole active negligence or sole willful misconduct of the Indemnified Party. If it is finally adjudicated that liability is caused by the comparative negligence or willful misconduct of the Indemnified Party, Licensee’s indemnification obligation shall be reduced in proportion to the established comparative liability of the Indemnified Party.

b. The duty to defend is a separate and distinct obligation from Licensee’s duty to indemnify. Licensee shall be obligated to defend, in all legal, equitable, administrative, or special proceedings, with counsel approved by the Indemnified Party immediately upon tender to Licensee of the claim in any form or at any stage of an action or proceeding, whether or not liability is

established. An allegation or determination of negligence or willful misconduct by the Indemnified Party shall not relieve Licensee from its separate and distinct obligation to defend the Indemnified Party. The obligation to defend extends through final judgment, including exhaustion of any appeals. The defense obligation includes the obligation to provide independent defense counsel if Licensee asserts that liability is caused in whole or in part by the negligence or willful misconduct of the Indemnified Party. If it is finally adjudicated that liability was caused by the sole active negligence or sole willful misconduct of the Indemnified Party, Licensee may submit a claim to PACC for reimbursement of reasonable attorneys' fees and defense costs.

c. This Section shall survive completion or termination of this Agreement. The provisions of this Section shall not be restricted by and do not affect the provisions of this Agreement relating to insurance.

33. Insurance

a. Licensee shall obtain and maintain in full force and effect during the use and occupation of Theater under this Agreement the insurance coverage's as specified in Exhibit C, attached hereto and incorporated in full herein by this reference, issued by a company satisfactory to Executive Director, unless Executive Director, waives, in writing, the requirement that Licensee obtain and maintain such insurance coverage's.

b. Licensee shall, prior to the use and occupation of Theater, file with Executive Director evidence of insurance coverage as specified in Exhibit D. Evidence of insurance coverage shall be forwarded to Executive Director, addressed as specified in Exhibit D.

c. Maintenance of proper insurance coverage's by Licensee is a material element of this Agreement. Licensee's failure to maintain or renew insurance coverage's or to provide evidence of renewal may be considered as a material breach of this Agreement.

34. Maintenance and Repair

Licensee agrees to maintain Theater and other portions of the premises of PACC to which Licensee, its employees, agents, licensees or any member of the public has access to by reason of this Agreement in good condition, reasonable wear and tear, damage by the elements, act of God, or casualties beyond the control of Licensee only excepted. Licensee agrees to return Theater in the same condition as before use of the same was permitted, ordinary wear and tear, damage by the elements, acts of God, or casualties beyond the control of Licensee excepted.

35. Default

a. Should Licensee default in the performance of any of the terms and conditions of this Agreement, PACC, at its option, may terminate the Agreement. Licensee shall be liable for the full amount of the fee provided for herein less fees received from others for use of Theater at the time, or times, specified in this Agreement.

b. Any deposit made by Licensee to PACC shall be retained by PACC.

36. Cancellation by PACC

a. In addition to the right to terminate this Agreement upon Licensee's default, PACC shall have the right:

(1) To terminate this Agreement at any time when Theater is required by public necessity or emergency use.

(2) To terminate this Agreement at any time, without liability to PACC, upon ten days written notice when Licensee proposes a special service event for which no fee is to be charged.

(3) To terminate this Agreement at any time without liability to PACC, upon 21 days written notice, in all other instances.

b. Upon termination by PACC, any deposit made by Licensee shall be refunded.

c. Licensee hereby waives any claim Licensee may have against PACC stemming from any cancellation of this Agreement by PACC prior to the date of the event.

37. Cancellation by Licensee

No cancellation by Licensee shall be accepted by Executive Director if less than 21 days prior to the date of the event. Failure to cancel prior to this time will subject Licensee to payment of all fees.

38. Attorneys' Fees

Licensee and PACC agree that the prevailing party's reasonable costs, attorneys' fees and expenses, including investigation fees and expert witness fees, shall be paid by the non-prevailing party in any dispute involving the terms and conditions of this Agreement.

39. Entire Agreement

Licensee and PACC agree that this Agreement constitutes the entire agreement of the parties regarding the subject matter described herein and supersedes all prior communications, agreements, and promises, either oral or written.

Signatures on next page

OXNARD PERFORMING ARTS
CENTER CORPORATION

LICENSEE
OXNARD SCHOOL DISTRICT

Oxnard Performing Arts Center Manager

Lisa A. Franz, Director, Purchasing

NOTE: This License Agreement is a standard agreement previously approved as to form by the City Attorney and the General Counsel.

OSD BOARD AGENDA ITEM

Name of Contributor: Dr. Anabolena DeGenna

Date of Meeting: 4/3/19

- Study Session:** _____
Closed Session _____
- A-1. Preliminary** _____
A-II. Reports _____
B. Hearings _____
C. Consent Agenda _____
- Agreement Category:**
____ Academic
____ Enrichment
X Special Education
____ Support Services
____ Personnel
____ Legal
____ Facilities
- D. Action Items** _____
F. Board Policies 1st Reading _____ 2nd Reading _____

Ratification of Agreement #18-216 – Casa Pacifica School (DeGenna/Sugden)

Requesting ratification for Non-Public School (NPS) services for Student GK041305, for the 2018-2019 school year, including Extended School Year. The Non-Public School will provide a program of instruction, which is consistent with the pupil's individual educational plan as specified in the individual service agreement.

Student: GK041305

FISCAL IMPACT:

Tuition: \$185.00 per diem x 95 days = \$17,575.00
(Including 20 days of Extended School Year)

Transportation: \$50 Round trip daily rate, for 95 days = \$4,750.00

Grand Total: **\$22,325.00** – Special Education Funds

RECOMMENDATION:

It is the recommendation of the Director, Special Education Services, and the Assistant Superintendent, Educational Services, that the Board of Trustees ratify Agreement #18-216 with Casa Pacifica School, NPS.

ADDITIONAL MATERIAL(S):

Attached: Agreement #18-216, Casa Pacifica School (4 Pages)



OXNARD SCHOOL DISTRICT

1051 South "A" Street • Oxnard, California 93030 • (805) 385-1501

AGREEMENT FOR NONPUBLIC, NONSECTARIAN SCHOOLING

AGREEMENT #18-216

THIS AGREEMENT, made and entered into this 3rd day of April 2019, by and between the OXNARD SCHOOL DISTRICT, hereinafter referred to as the District, and CASA PACIFICA SCHOOL, hereinafter referred to as the nonpublic, nonsectarian school.

WITNESSETH:

WHEREAS, the District is authorized by the provisions of the California Education Code, Section 56155 et seq., to contract with a nonpublic, nonsectarian school to provide services for certain pupils who are unable to benefit from regular education; and

WHEREAS, the District has determined, through evaluation and individual educational plans, that the following pupils are in need of such services;

Student: GK041305

NOW, THEREFORE, in consideration of their mutual promises contained herein, the parties hereto enter into a fixed price contract as follows:

1. The nonpublic school will provide a program of instruction which is consistent with the pupil's individual educational plan as specified in the individual service agreement attached hereto and made a part hereof, and that the nonpublic, nonsectarian schools basic educational program and designated instruction and services shall be described in a written statement to be provided to the school district prior to the execution of this agreement.
2. Services shall be provided for the **2018-2019** school year at a daily rate of \$185.00 for 95 days; this includes 20 days of extended school year through July 12, 2019, a \$50 daily rate for round trip transportation services for 95 days; not to exceed **\$22,325.00.**
3. The nonpublic school shall keep attendance of each pupil daily and shall report attendance monthly to the school district. Such attendance records shall be kept in a California State school register and copies of such register shall be filed with monthly invoices to the district within thirty (30) days after the close of the school month. Separate attendance registers shall be submitted for all designated instruction and services.



OXNARD SCHOOL DISTRICT

1051 South "A" Street • Oxnard, California 93030 • (805) 385-1501

AGREEMENT #18-216

Page 2

4. The nonpublic school will notify the school district of any change in a pupil's placement and/or address within three (3) days after the nonpublic school is informed of such changes.

5. The nonpublic school will report within three (3) days to the school district if a pupil is removed from the school by the placement agency, parent or legal guardian, or if a pupil absents himself/herself from school without permission for more than five (5) consecutive school days. For the purposes of the contract, a parent is the natural or adoptive parent, legal guardian or surrogate parent appointed by the district of residence when the courts have removed the parents educational rights.

6. The nonpublic school shall notify the school district when a pupil is absent for five (5) consecutive school days because of illness. Notification will be in writing.

7. *The nonpublic school will not be paid for excused absences due to changes in the ADA laws. These absences shall count as non-instructional days and not compensated at the daily rate.*

8. The nonpublic school shall prepare and submit to the school district year-end reports and other data required for the annual review on or before April 15 of the current school year. Forms for year-end and other required reports shall be provided by the school district via the computerized special education support program (SESP).

9. In consideration of the services to be rendered by the nonpublic, nonsectarian school, the district agrees to payment as follows:

All cost for this service, including intake, testing, tuition, and elective not to exceed **\$22,325.00** for **Student: GK041305**.

10. While engaged in carrying out and complying with the terms of this agreement, the nonpublic, nonsectarian school is an independent contractor and not an officer, agent, or employee of the district. The independent contractor will obtain a criminal record summary from the Department of Justice or a Department of Justice approved agency on all employees or contracted service providers who potentially have contact with students. This clearance will be completed prior to the person(s) first day of employment. No individual who has been convicted of a violent or serious felony as listed in subdivision C, of Section 1192.7 of the California Penal Code will be employed in any capacity that potentially involves contact with students. Nor will any person be employed who has been convicted of, or entered a plea of nolo contendere to charges of any sex offense as defined in Education Code 44011.



OXNARD SCHOOL DISTRICT

1051 South "A" Street • Oxnard, California 93030 • (805) 385-1501

AGREEMENT #18-216

Page 3

11. The school district may withhold payment to the nonpublic, nonsectarian school when, in the opinion of the district: (1) nonpublic school's performance in whole or in part, either has not been sufficient or is insufficiently documented, or: (2) nonpublic school has neglected, failed, or refused to provide information or to cooperate with the inspection, review or audit of the program conducted by nonpublic school or records relating thereto. The school district shall not withhold payments as specified in this paragraph unless the school district has notified the nonpublic, nonsectarian school, in writing, that nonpublic, nonsectarian school has not performed as specified herein. The notice shall specify that nonpublic, nonsectarian school has fourteen (14) days to make the required corrections. If, after the expiration of the fourteen (14) days, nonpublic, nonsectarian school has not corrected the situation as specified in the district's notice, the affected payments will be withheld and this agreement may be canceled for cause.

12. During the entire term of this agreement and any extension or modification thereof, the nonpublic school shall keep in effect a policy or policies of liability insurance, including coverage of owned and non-owned automobiles operated by nonpublic school for the purposes of this agreement, of at least \$1,000,000 for each person and \$1,000,000 for each accident or occurrence from all damages arising out of death, bodily injury, sickness, or disease from any one accident or occurrence, and \$3,000,000 for all damages and liability arising out of injury to or destruction of property for each accident or occurrence. Not later than the effective date of this contract, the nonpublic school shall provide the District with satisfactory evidence of insurance, naming the District as additional insured, including a provision for a twenty (20) calendar day written notice to District before cancellation or material change, evidencing the above specified coverage. The Nonpublic school shall at its own cost and expense, procure and maintain insurance under the Worker's Compensation Law of California. Said certificates shall specify that insurance shall not be canceled or changed in required limits unless the school district has been provided forty-five (45) days advance written notification of cancellation or change. The nonpublic, nonsectarian school shall also maintain Workers' Compensation Insurance coverage as required by law.

13. This Agreement, or any of its rights, obligations, provisions, or conditions, may not be assigned by either party without the written consent of the party.

14. This Agreement may be amended by mutual agreement of the parties and may be terminated by either party upon twenty (20) days advance notification.



OXNARD SCHOOL DISTRICT

1051 South "A" Street • Oxnard, California 93030 • (805) 385-1501

AGREEMENT #18-216

Page 4

IN WITNESS WHEREOF, the parties hereto have set their hands on the day and year first above written.

Date

Lisa A. Franz, Director, Purchasing
Oxnard School District

Date

Sara Terwall, Director of Finance
Casa Pacifica School, Nonpublic, Nonsectarian School

OSD BOARD AGENDA ITEM

Name of Contributor: Dr. Anabolena DeGenna

Date of Meeting: 4/3/19

- Study Session:** _____
Closed Session _____
- A-1. Preliminary** _____
A-II. Reports _____
B. Hearings _____
C. Consent Agenda _____
- Agreement Category:**
____ Academic
____ Enrichment
X Special Education
____ Support Services
____ Personnel
____ Legal
____ Facilities
- D. Action Items** _____
F. Board Policies 1st Reading _____ **2nd Reading** _____

Ratification of Agreement #18-217 – Casa Pacifica School (DeGenna/Sugden)

Requesting ratification for Non-Public School (NPS) services for Student KP033105, for the 2018-2019 school year, including Extended School Year. The Non-Public School will provide a program of instruction, which is consistent with the pupil's individual educational plan as specified in the individual service agreement.

Student: KP033105

FISCAL IMPACT:

Tuition: \$185.00 per diem x 110 days = \$20,350.00
(Including 20 days of Extended School Year)

Paraeducator 1:1: \$39.00 per hour x (1,800 minutes) 30 hours per week = \$1,170.00
\$1,170.00 x 24 weeks = \$28,080.00

Transportation: \$50 Round trip daily rate, for 110 days = \$5,500.00

Grand Total: \$53,930.00 – Special Education Funds

RECOMMENDATION:

It is the recommendation of the Director, Special Education Services, and the Assistant Superintendent, Educational Services, that the Board of Trustees ratify Agreement #18-217 with Casa Pacifica School, NPS.

ADDITIONAL MATERIAL(S):

Attached: Agreement #18-217, Casa Pacifica School (4 Pages)



OXNARD SCHOOL DISTRICT

1051 South "A" Street • Oxnard, California 93030 • (805) 385-1501

AGREEMENT FOR NONPUBLIC, NONSECTARIAN SCHOOLING

AGREEMENT #18-217

THIS AGREEMENT, made and entered into this 3rd day of April 2019, by and between the OXNARD SCHOOL DISTRICT, hereinafter referred to as the District, and CASA PACIFICA SCHOOL, hereinafter referred to as the nonpublic, nonsectarian school.

WITNESSETH:

WHEREAS, the District is authorized by the provisions of the California Education Code, Section 56155 et seq., to contract with a nonpublic, nonsectarian school to provide services for certain pupils who are unable to benefit from regular education; and

WHEREAS, the District has determined, through evaluation and individual educational plans, that the following pupils are in need of such services;

Student: KP033105

NOW, THEREFORE, in consideration of their mutual promises contained herein, the parties hereto enter into a fixed price contract as follows:

1. The nonpublic school will provide a program of instruction which is consistent with the pupil's individual educational plan as specified in the individual service agreement attached hereto and made a part hereof, and that the nonpublic, nonsectarian schools basic educational program and designated instruction and services shall be described in a written statement to be provided to the school district prior to the execution of this agreement.
2. Services shall be provided for the **2018-2019** school year at a daily rate of \$185.00 for 110 days; this includes 20 days of extended school year through July 12, 2019, a \$50 daily rate for round trip transportation for 110 days; Paraeducator 1:1 services at an hourly rate of \$39 for 30 hours for 24 weeks; services not to exceed **\$53,930.00**
3. The nonpublic school shall keep attendance of each pupil daily and shall report attendance monthly to the school district. Such attendance records shall be kept in a California State school register and copies of such register shall be filed with monthly invoices to the district within thirty (30) days after the close of the school month. Separate attendance registers shall be submitted for all designated instruction and services.



OXNARD SCHOOL DISTRICT

1051 South "A" Street • Oxnard, California 93030 • (805) 385-1501

AGREEMENT #18-217

Page 2

4. The nonpublic school will notify the school district of any change in a pupil's placement and/or address within three (3) days after the nonpublic school is informed of such changes.

5. The nonpublic school will report within three (3) days to the school district if a pupil is removed from the school by the placement agency, parent or legal guardian, or if a pupil absents himself/herself from school without permission for more than five (5) consecutive school days. For the purposes of the contract, a parent is the natural or adoptive parent, legal guardian or surrogate parent appointed by the district of residence when the courts have removed the parents educational rights.

6. The nonpublic school shall notify the school district when a pupil is absent for five (5) consecutive school days because of illness. Notification will be in writing.

7. *The nonpublic school will not be paid for excused absences due to changes in the ADA laws. These absences shall count as non-instructional days and not compensated at the daily rate.*

8. The nonpublic school shall prepare and submit to the school district year-end reports and other data required for the annual review on or before April 15 of the current school year. Forms for year-end and other required reports shall be provided by the school district via the computerized special education support program (SESP).

9. In consideration of the services to be rendered by the nonpublic, nonsectarian school, the district agrees to payment as follows:

All cost for this service, including intake, testing, tuition, and elective not to exceed **\$53,930.00** for **Student: KP033105**

10. While engaged in carrying out and complying with the terms of this agreement, the nonpublic, nonsectarian school is an independent contractor and not an officer, agent, or employee of the district. The independent contractor will obtain a criminal record summary from the Department of Justice or a Department of Justice approved agency on all employees or contracted service providers who potentially have contact with students. This clearance will be completed prior to the person(s) first day of employment. No individual who has been convicted of a violent or serious felony as listed in subdivision C, of Section 1192.7 of the California Penal Code will be employed in any capacity that potentially involves contact with students. Nor will any person be employed who has been convicted of, or entered a plea of nolo contendere to charges of any sex offense as defined in Education Code 44011.



OXNARD SCHOOL DISTRICT

1051 South "A" Street • Oxnard, California 93030 • (805) 385-1501

AGREEMENT #18-217

Page 3

11. The school district may withhold payment to the nonpublic, nonsectarian school when, in the opinion of the district: (1) nonpublic school's performance in whole or in part, either has not been sufficient or is insufficiently documented, or: (2) nonpublic school has neglected, failed, or refused to provide information or to cooperate with the inspection, review or audit of the program conducted by nonpublic school or records relating thereto. The school district shall not withhold payments as specified in this paragraph unless the school district has notified the nonpublic, nonsectarian school, in writing, that nonpublic, nonsectarian school has not performed as specified herein. The notice shall specify that nonpublic, nonsectarian school has fourteen (14) days to make the required corrections. If, after the expiration of the fourteen (14) days, nonpublic, nonsectarian school has not corrected the situation as specified in the district's notice, the affected payments will be withheld and this agreement may be canceled for cause.

12. During the entire term of this agreement and any extension or modification thereof, the nonpublic school shall keep in effect a policy or policies of liability insurance, including coverage of owned and non-owned automobiles operated by nonpublic school for the purposes of this agreement, of at least \$1,000,000 for each person and \$1,000,000 for each accident or occurrence from all damages arising out of death, bodily injury, sickness, or disease from any one accident or occurrence, and \$3,000,000 for all damages and liability arising out of injury to or destruction of property for each accident or occurrence. Not later than the effective date of this contract, the nonpublic school shall provide the District with satisfactory evidence of insurance, naming the District as additional insured, including a provision for a twenty (20) calendar day written notice to District before cancellation or material change, evidencing the above specified coverage. The Nonpublic school shall at its own cost and expense, procure and maintain insurance under the Worker's Compensation Law of California. Said certificates shall specify that insurance shall not be canceled or changed in required limits unless the school district has been provided forty-five (45) days advance written notification of cancellation or change. The nonpublic, nonsectarian school shall also maintain Workers' Compensation Insurance coverage as required by law.

13. This Agreement, or any of its rights, obligations, provisions, or conditions, may not be assigned by either party without the written consent of the party.

14. This Agreement may be amended by mutual agreement of the parties and may be terminated by either party upon twenty (20) days advance notification.



OXNARD SCHOOL DISTRICT

1051 South "A" Street • Oxnard, California 93030 • (805) 385-1501

AGREEMENT #18-217

Page 4

IN WITNESS WHEREOF, the parties hereto have set their hands on the day and year first above written.

Date

Lisa A. Franz, Director, Purchasing
Oxnard School District

Date

Sara Terwall, Director of Finance
Casa Pacifica School, Nonpublic, Nonsectarian School

OSD BOARD AGENDA ITEM

Name of Contributor: Dr. Anabolena DeGenna

Date of Meeting: 4/3/19

- Study Session:** _____
 - Closed Session** _____
 - A-1. Preliminary** _____
 - A-II. Reports** _____
 - B. Hearings** _____
 - C. Consent Agenda** _____
- Agreement Category:**
- ___ Academic
 - ___ Enrichment
 - X Special Education**
 - ___ Support Services
 - ___ Personnel
 - ___ Legal
 - ___ Facilities
- D. Action Items** _____
- F. Board Policies** 1st Reading _____ 2nd Reading _____

Ratification of Agreement #18-218 – Casa Pacifica School (DeGenna/Sugden)

Requesting ratification for Non-Public School (NPS) services for Student AT031605, for the 2018-2019 school year, including Extended School Year. The Non-Public School will provide a program of instruction, which is consistent with the pupil's individual educational plan as specified in the individual service agreement.

Student: AT031605

FISCAL IMPACT:

Tuition: \$185.00 per diem x 109 days = \$20,165.00
(Including 20 days of Extended School Year)

Paraeducator 1:1: \$39.00 per hours x (1,500 minutes) 25 hours per week = \$975.00
\$975.00 x 24 weeks = \$23,400.00

Transportation: \$50 Round trip daily rate, for 109 days = \$5,450.00

Grand Total: \$49,015.00 – Special Education Funds

RECOMMENDATION:

It is the recommendation of the Director, Special Education Services, and the Assistant Superintendent, Educational Services, that the Board of Trustees ratify Agreement #18-218 with Casa Pacifica School, NPS.

ADDITIONAL MATERIAL(S):

Attached: Agreement #18-218, Casa Pacifica School (4 Pages)



OXNARD SCHOOL DISTRICT

1051 South "A" Street • Oxnard, California 93030 • (805) 385-1501

AGREEMENT FOR NONPUBLIC, NONSECTARIAN SCHOOLING

AGREEMENT #18-218

THIS AGREEMENT, made and entered into this 3rd day of April 2019, by and between the OXNARD SCHOOL DISTRICT, hereinafter referred to as the District, and CASA PACIFICA SCHOOL, hereinafter referred to as the nonpublic, nonsectarian school.

WITNESSETH:

WHEREAS, the District is authorized by the provisions of the California Education Code, Section 56155 et seq., to contract with a nonpublic, nonsectarian school to provide services for certain pupils who are unable to benefit from regular education; and

WHEREAS, the District has determined, through evaluation and individual educational plans, that the following pupils are in need of such services;

Student: AT031605

NOW, THEREFORE, in consideration of their mutual promises contained herein, the parties hereto enter into a fixed price contract as follows:

1. The nonpublic school will provide a program of instruction which is consistent with the pupil's individual educational plan as specified in the individual service agreement attached hereto and made a part hereof, and that the nonpublic, nonsectarian schools basic educational program and designated instruction and services shall be described in a written statement to be provided to the school district prior to the execution of this agreement.
2. Services shall be provided for the **2018-2019** school year at a daily rate of \$185.00 for 109 days; this includes 20 days of extended school year through July 12, 2019, a \$50 daily rate for round trip transportation for 109 days; Paraeducator 1:1 services at an hourly rate of \$39 for 25 hours for 24 weeks; services not to exceed **\$49,015.00**
3. The nonpublic school shall keep attendance of each pupil daily and shall report attendance monthly to the school district. Such attendance records shall be kept in a California State school register and copies of such register shall be filed with monthly invoices to the district within thirty (30) days after the close of the school month. Separate attendance registers shall be submitted for all designated instruction and services.



OXNARD SCHOOL DISTRICT

1051 South "A" Street • Oxnard, California 93030 • (805) 385-1501

AGREEMENT #18-218

Page 2

4. The nonpublic school will notify the school district of any change in a pupil's placement and/or address within three (3) days after the nonpublic school is informed of such changes.

5. The nonpublic school will report within three (3) days to the school district if a pupil is removed from the school by the placement agency, parent or legal guardian, or if a pupil absents himself/herself from school without permission for more than five (5) consecutive school days. For the purposes of the contract, a parent is the natural or adoptive parent, legal guardian or surrogate parent appointed by the district of residence when the courts have removed the parents educational rights.

6. The nonpublic school shall notify the school district when a pupil is absent for five (5) consecutive school days because of illness. Notification will be in writing.

7. *The nonpublic school will not be paid for excused absences due to changes in the ADA laws. These absences shall count as non-instructional days and not compensated at the daily rate.*

8. The nonpublic school shall prepare and submit to the school district year-end reports and other data required for the annual review on or before April 15 of the current school year. Forms for year-end and other required reports shall be provided by the school district via the computerized special education support program (SESP).

9. In consideration of the services to be rendered by the nonpublic, nonsectarian school, the district agrees to payment as follows:

All cost for this service, including intake, testing, tuition, and elective not to exceed **\$49,015.00** for **Student: AT031605**

10. While engaged in carrying out and complying with the terms of this agreement, the nonpublic, nonsectarian school is an independent contractor and not an officer, agent, or employee of the district. The independent contractor will obtain a criminal record summary from the Department of Justice or a Department of Justice approved agency on all employees or contracted service providers who potentially have contact with students. This clearance will be completed prior to the person(s) first day of employment. No individual who has been convicted of a violent or serious felony as listed in subdivision C, of Section 1192.7 of the California Penal Code will be employed in any capacity that potentially involves contact with students. Nor will any person be employed who has been convicted of, or entered a plea of nolo contendere to charges of any sex offense as defined in Education Code 44011.



OXNARD SCHOOL DISTRICT

1051 South "A" Street • Oxnard, California 93030 • (805) 385-1501

AGREEMENT #18-218

Page 3

11. The school district may withhold payment to the nonpublic, nonsectarian school when, in the opinion of the district: (1) nonpublic school's performance in whole or in part, either has not been sufficient or is insufficiently documented, or: (2) nonpublic school has neglected, failed, or refused to provide information or to cooperate with the inspection, review or audit of the program conducted by nonpublic school or records relating thereto. The school district shall not withhold payments as specified in this paragraph unless the school district has notified the nonpublic, nonsectarian school, in writing, that nonpublic, nonsectarian school has not performed as specified herein. The notice shall specify that nonpublic, nonsectarian school has fourteen (14) days to make the required corrections. If, after the expiration of the fourteen (14) days, nonpublic, nonsectarian school has not corrected the situation as specified in the district's notice, the affected payments will be withheld and this agreement may be canceled for cause.

12. During the entire term of this agreement and any extension or modification thereof, the nonpublic school shall keep in effect a policy or policies of liability insurance, including coverage of owned and non-owned automobiles operated by nonpublic school for the purposes of this agreement, of at least \$1,000,000 for each person and \$1,000,000 for each accident or occurrence from all damages arising out of death, bodily injury, sickness, or disease from any one accident or occurrence, and \$3,000,000 for all damages and liability arising out of injury to or destruction of property for each accident or occurrence. Not later than the effective date of this contract, the nonpublic school shall provide the District with satisfactory evidence of insurance, naming the District as additional insured, including a provision for a twenty (20) calendar day written notice to District before cancellation or material change, evidencing the above specified coverage. The Nonpublic school shall at its own cost and expense, procure and maintain insurance under the Worker's Compensation Law of California. Said certificates shall specify that insurance shall not be canceled or changed in required limits unless the school district has been provided forty-five (45) days advance written notification of cancellation or change. The nonpublic, nonsectarian school shall also maintain Workers' Compensation Insurance coverage as required by law.

13. This Agreement, or any of its rights, obligations, provisions, or conditions, may not be assigned by either party without the written consent of the party.

14. This Agreement may be amended by mutual agreement of the parties and may be terminated by either party upon twenty (20) days advance notification.



OXNARD SCHOOL DISTRICT

1051 South "A" Street • Oxnard, California 93030 • (805) 385-1501

AGREEMENT #18-218

Page 4

IN WITNESS WHEREOF, the parties hereto have set their hands on the day and year first above written.

Date

Lisa A. Franz, Director, Purchasing
Oxnard School District

Date

Sara Terwall, Director of Finance
Casa Pacifica School, Nonpublic, Nonsectarian School

OSD BOARD AGENDA ITEM

Name of Contributor: Dr. Anabolena DeGenna

Date of Meeting: 4/3/19

- Study Session: _____
 - Closed Session: _____
 - A-1. Preliminary: _____
 - A-II. Reports: _____
 - B. Hearings: _____
 - C. Consent Agenda: _____
- Agreement Category:**
 Academic
 Enrichment
 Special Education
 Support Services
 Personnel
 Legal
 Facilities
- D. Action Items: _____
 - F. Board Policies 1st Reading: _____ 2nd Reading: _____

Ratification of Agreement #18-222 – Academy for Advancement of Children with Autism Inc. (DeGenna/Sugden)

Requesting ratification for Non-Public School (NPS) services for Student RD042105, for the 2018-2019 school year, including Extended School Year. The Non-Public School will provide a program of instruction, which is consistent with the pupil's individual educational plan as specified in the individual service agreement.

Student: RD042105

FISCAL IMPACT:

Tuition:	\$162.11 per diem x 82 days = \$13,293.02 (Including 29 days of Extended School Year)
Adapted Physical Education:	\$87.00 per hour x 17 hours = \$1,479.00
Speech/Language Services:	\$122.40 per hour x 15.5833 hours = \$1,907.40
Occupational Therapy:	\$120.00 per hour x 21.25 hours = \$2,550.00
Paraeducator 1:1 (1 st Aide):	\$40.48 per hour x 6 hours per day x 82 days = \$19,916.16
Paraeducator 1:1 (2 nd Aide):	\$40.48 per hour x 6 hours per day x 82 days = \$19,916.16
Transportation Aide:	\$195.00 per day x 82 days = \$15,990.00
Behavior Intervention Services:	\$109.00 per hour x 51 hours = \$5,559.00
Grand Total:	<u>\$80,610.74</u> – Special Education Funds

RECOMMENDATION:

It is the recommendation of the Director, Special Education Services, and the Assistant Superintendent, Educational Services, that the Board of Trustees ratify Agreement #18-222 with Academy for Advancement of Children with Autism Inc.

ADDITIONAL MATERIAL(S):

Attached: Agreement #18-222, Academy for Advancement of Children with Autism Inc. (4 Pages)



OXNARD SCHOOL DISTRICT

1051 South "A" Street • Oxnard, California 93030 • (805) 385-1501

AGREEMENT FOR NONPUBLIC, NONSECTARIAN SCHOOLING

AGREEMENT #18-222

THIS AGREEMENT, made and entered into this 3rd day of April 2019, by and between the OXNARD SCHOOL DISTRICT, hereinafter referred to as the District, and ACADEMY FOR ADVANCEMENT OF CHILDREN WITH AUTISM INC., hereinafter referred to as the nonpublic, nonsectarian school.

WITNESSETH:

WHEREAS, the District is authorized by the provisions of the California Education Code, Section 56155 et seq., to contract with a nonpublic, nonsectarian school to provide services for certain pupils who are unable to benefit from regular education; and

WHEREAS, the District has determined, through evaluation and individual educational plans, that the following pupils are in need of such services;

Student: RD042105

NOW, THEREFORE, in consideration of their mutual promises contained herein, the parties hereto enter into a fixed price contract as follows:

1. The nonpublic school will provide a program of instruction which is consistent with the pupil's individual educational plan as specified in the individual service agreement attached hereto and made a part hereof, and that the nonpublic, nonsectarian schools basic educational program and designated instruction and services shall be described in a written statement to be provided to the school district prior to the execution of this agreement.

2. Services shall be provided for the **2018-2019** school year at a daily rate of \$162.11 for 82 days; this includes 29 days of extended school year through July 19, 2019; 17 hours of adapted physical education at an hourly rate of \$87; 15.5833 hours of individual/group speech therapy at an hourly rate of \$122.40; 21.25 hours of occupational therapy at a rate of \$120; (2) 6 hour Paraeducator 1:1 services each for 82 days for a daily rate of \$485.76; a transportation aide at a daily rate of \$195 for 82 days; 51 hours of behavior intervention services at a rate of \$109; services not to exceed **\$80,610.74**

3. The nonpublic school shall keep attendance of each pupil daily and shall report attendance monthly to the school district. Such attendance records shall be kept in a California State school register and copies of such register shall be filed with monthly invoices to the district within thirty (30) days after the close of the school month. Separate attendance registers shall be submitted for all designated instruction and services.



OXNARD SCHOOL DISTRICT

1051 South "A" Street • Oxnard, California 93030 • (805) 385-1501

AGREEMENT #18-222

Page 2

4. The nonpublic school will notify the school district of any change in a pupil's placement and/or address within three (3) days after the nonpublic school is informed of such changes.

5. The nonpublic school will report within three (3) days to the school district if a pupil is removed from the school by the placement agency, parent or legal guardian, or if a pupil absents himself/herself from school without permission for more than five (5) consecutive school days. For the purposes of the contract, a parent is the natural or adoptive parent, legal guardian or surrogate parent appointed by the district of residence when the courts have removed the parents educational rights.

6. The nonpublic school shall notify the school district when a pupil is absent for five (5) consecutive school days because of illness. Notification will be in writing.

7. *The nonpublic school will not be paid for excused absences due to changes in the ADA laws. These absences shall count as non-instructional days and not compensated at the daily rate.*

8. The nonpublic school shall prepare and submit to the school district year-end reports and other data required for the annual review on or before April 15 of the current school year. Forms for year-end and other required reports shall be provided by the school district via the computerized special education support program (SESP).

9. In consideration of the services to be rendered by the nonpublic, nonsectarian school, the district agrees to payment as follows:

All cost for this service, including intake, testing, tuition, and elective not to exceed **\$80,610.74** for **Student: RD042105**

10. While engaged in carrying out and complying with the terms of this agreement, the nonpublic, nonsectarian school is an independent contractor and not an officer, agent, or employee of the district. The independent contractor will obtain a criminal record summary from the Department of Justice or a Department of Justice approved agency on all employees or contracted service providers who potentially have contact with students. This clearance will be completed prior to the person(s) first day of employment. No individual who has been convicted of a violent or serious felony as listed in subdivision C, of Section 1192.7 of the California Penal Code will be employed in any capacity that potentially involves contact with students. Nor will any person be employed who has been convicted of, or entered a plea of nolo contendere to charges of any sex offense as defined in Education Code 44011.



OXNARD SCHOOL DISTRICT

1051 South "A" Street • Oxnard, California 93030 • (805) 385-1501

AGREEMENT #18-222

Page 3

11. The school district may withhold payment to the nonpublic, nonsectarian school when, in the opinion of the district: (1) nonpublic school's performance in whole or in part, either has not been sufficient or is insufficiently documented, or: (2) nonpublic school has neglected, failed, or refused to provide information or to cooperate with the inspection, review or audit of the program conducted by nonpublic school or records relating thereto. The school district shall not withhold payments as specified in this paragraph unless the school district has notified the nonpublic, nonsectarian school, in writing, that nonpublic, nonsectarian school has not performed as specified herein. The notice shall specify that nonpublic, nonsectarian school has fourteen (14) days to make the required corrections. If, after the expiration of the fourteen (14) days, nonpublic, nonsectarian school has not corrected the situation as specified in the district's notice, the affected payments will be withheld and this agreement may be canceled for cause.

12. During the entire term of this agreement and any extension or modification thereof, the nonpublic school shall keep in effect a policy or policies of liability insurance, including coverage of owned and non-owned automobiles operated by nonpublic school for the purposes of this agreement, of at least \$1,000,000 for each person and \$1,000,000 for each accident or occurrence from all damages arising out of death, bodily injury, sickness, or disease from any one accident or occurrence, and \$3,000,000 for all damages and liability arising out of injury to or destruction of property for each accident or occurrence. Not later than the effective date of this contract, the nonpublic school shall provide the District with satisfactory evidence of insurance, naming the District as additional insured, including a provision for a twenty (20) calendar day written notice to District before cancellation or material change, evidencing the above specified coverage. The Nonpublic school shall at its own cost and expense, procure and maintain insurance under the Worker's Compensation Law of California. Said certificates shall specify that insurance shall not be canceled or changed in required limits unless the school district has been provided forty-five (45) days advance written notification of cancellation or change. The nonpublic, nonsectarian school shall also maintain Workers' Compensation Insurance coverage as required by law.

13. This Agreement, or any of its rights, obligations, provisions, or conditions, may not be assigned by either party without the written consent of the party.

14. This Agreement may be amended by mutual agreement of the parties and may be terminated by either party upon twenty (20) days advance notification.



OXNARD SCHOOL DISTRICT

1051 South "A" Street • Oxnard, California 93030 • (805) 385-1501

AGREEMENT #18-222

Page 4

IN WITNESS WHEREOF, the parties hereto have set their hands on the day and year first above written.

Date

Lisa A. Franz, Director, Purchasing
Oxnard School District

Date

Karin Vanderpool, Clinical Services Coordinator
Academy for Advancement of Children with Autism, Inc.,
Nonpublic, Nonsectarian School

OSD BOARD AGENDA ITEM

Name of Contributor: Dr. Anabolena DeGenna

Date of Meeting: 4/3/19

- Study Session:** _____
Closed Session _____
- A-1. Preliminary** _____
A-II. Reports _____
B. Hearings _____
C. Consent Agenda _____
- Agreement Category:**
____ Academic
____ Enrichment
X Special Education
____ Support Services
____ Personnel
____ Legal
____ Facilities
- D. Action Items** _____
F. Board Policies 1st Reading _____ **2nd Reading** _____

Ratification of Agreement #18-223 - Ventura County Office of Education, Special Circumstances Paraeducator Services - SCP (DeGenna/Sugden)

It is recommended that the Board of Trustees ratify the service agreements with Ventura County Office of Education (VCOE) for the 2018-2019 school year, to provide exceptional services to special education students that consist of support from Special Circumstances Paraeducators (SCP's), including Extended School Year.

Students 2018-2019:

NC092306	\$29,955.50
OL083008	\$23,604.13
EG061410	\$25,991.09
RR103108	\$21,527.28

FISCAL IMPACT:

\$101,078.00 - Special Education Funds

RECOMMENDATION:

It is the recommendation of the Director, Special Education Services, and the Assistant Superintendent, Educational Services, that the Board of Trustees ratify Agreement #18-223 with the Ventura County Office of Education for Special Circumstances Paraeducator Services (SCP's), in the amount of \$101,078.00.

ADDITIONAL MATERIAL(S):

Attached: Agreement #18-223, Ventura County Office of Education (4 Pages)



AGREEMENT

For Paraeducator Performing Special Circumstance Educational Support

This Agreement, effective **January 9, 2019** is made by and between the Ventura County Office of Education, hereinafter referred to as SUPERINTENDENT, and the **Oxnard School District**, hereinafter referred to as DISTRICT.

NC092306

1. This agreement pertains to providing exceptional service(s) for, [REDACTED], a Special Education pupil who is a resident of DISTRICT and currently attends **James Foster School** a special education program operated by SUPERINTENDENT.
2. SUPERINTENDENT agrees to provide for the exceptional service(s) of such Special Education pupil as authorized by DISTRICT or its designee and agreed to by SUPERINTENDENT.
3. DISTRICT shall reimburse SUPERINTENDENT the actual cost of providing the exceptional service plus the state approved indirect cost rate of SUPERINTENDENT.

Authorized exceptional service(s) shall consist of Paraeducator performing special circumstance educational support throughout the school day (330 minutes a day) and during transportation to and from school (60 minutes a day) for a total of 390 min daily. ESY will be calculated at 280 minutes a day.

4. DISTRICT acknowledges that certain types of expenses will continue to accrue during periods of student's absence from school, including but not limited to salary and benefits of staff providing the exceptional service(s). DISTRICT further acknowledges that if the exceptional service(s) includes the service(s) of SUPERINTENDENT's employee(s), 45 days' notice is required to layoff an employee for lack of work. Therefore, in the event the student unexpectedly leaves SUPERINTENDENT's program, SUPERINTENDENT will make every attempt to re-assign any staff involved in providing the exceptional service(s); however, if that is not possible, DISTRICT will reimburse SUPERINTENDENT for expense incurred throughout the layoff notice period.
5. DISTRICT does hereby agree to defend, indemnify and hold harmless the SUPERINTENDENT, the Ventura County Board of Education, and its officers, and employees from any and all claims, demands, liabilities, expenses (including attorneys' fees and costs of defense) arising as a result of SUPERINTENDENT's obligations under this agreement. However, this indemnification shall not apply if it is ultimately adjudicated that such claim, demand, liability or expense arose out of the sole negligence of the SUPERINTENDENT.
6. The term of this contract shall begin **1/9/2019 (IEP date)** and continue thereafter on a continuing basis until the IEP of said student is modified or until student's district of residence changes.

FISCAL YEAR-based on IEP date: (including ESY, if applicable)	CURRENT: <u>2018-2019</u> <u>1/9/2019-6/7/2019</u> (ESY: <u>6/10/2019-6/28/2019</u>)		UPCOMING: <u>2019-2020</u> (ESY: <u>7/1/2019-7/5/2019</u>) <u>8/14/2019-12/18/2019</u>
	\$ <u>29,955.50</u>	+	\$ <u>TBD</u>

It shall be the responsibility of DISTRICT to notify SUPERINTENDENT of any change in district of residence or change in the IEP that would affect this contract.

IN WITNESS WHEREOF, the parties hereto have executed this agreement:

OXNARD SCHOOL DISTRICT

VENTURA COUNTY OFFICE OF EDUCATION

Signature (DOR Authorized Representative)
Lisa A. Franz

Accepted By: [Signature]
Special Education Authorized Representative

Title: Director, Purchasing

Approved By: _____
VCOE Business Services Authorized Representative

Date: _____

Date: _____

Estimated Cost \$ 29,955.50



AGREEMENT

For Paraeducator Performing Special Circumstance Educational Support

This Agreement, effective **February 21, 2019** is made by and between the Ventura County Office of Education, hereinafter referred to as SUPERINTENDENT, and the Oxnard School District, hereinafter referred to as DISTRICT.

OL083008

1. This agreement pertains to providing exceptional service(s) for, [REDACTED] a Special Education pupil who is a resident of DISTRICT and currently attends Douglas Penfield School a special education program operated by SUPERINTENDENT.
2. SUPERINTENDENT agrees to provide for the exceptional service(s) of such Special Education pupil as authorized by DISTRICT or its designee and agreed to by SUPERINTENDENT.
3. DISTRICT shall reimburse SUPERINTENDENT the actual cost of providing the exceptional service plus the state approved indirect cost rate of SUPERINTENDENT.

Authorized exceptional service(s) shall consist of **Paraeducator performing special circumstance support throughout the school day for a total of 330 minutes a day. ESY will be provided at 240 minutes a day.**

4. DISTRICT acknowledges that certain types of expenses will continue to accrue during periods of student's absence from school, including but not limited to salary and benefits of staff providing the exceptional service(s). DISTRICT further acknowledges that if the exceptional service(s) includes the service(s) of SUPERINTENDENT's employee(s), 45 days' notice is required to layoff an employee for lack of work. Therefore, in the event the student unexpectedly leaves SUPERINTENDENT's program, SUPERINTENDENT will make every attempt to re-assign any staff involved in providing the exceptional service(s); however, if that is not possible, DISTRICT will reimburse SUPERINTENDENT for expense incurred throughout the layoff notice period.
5. DISTRICT does hereby agree to defend, indemnify and hold harmless the SUPERINTENDENT, the Ventura County Board of Education, and its officers, and employees from any and all claims, demands, liabilities, expenses (including attorneys' fees and costs of defense) arising as a result of SUPERINTENDENT's obligations under this agreement. However, this indemnification shall not apply if it is ultimately adjudicated that such claim, demand, liability or expense arose out of the sole negligence of the SUPERINTENDENT.
6. The term of this contract shall begin 2/21/2019 (IEP date) and continue thereafter on a continuing basis until the IEP of said student is modified or until student's district of residence changes.

FISCAL YEAR-based on IEP date: (including ESY, if applicable)	CURRENT: <u>2018-2019</u> <u>2/21/2019-6/7/2019</u> (ESY: <u>6/10/2019-6/28/2019</u>)		UPCOMING: <u>2019-2020</u> (ESY: <u>7/1/2019-7/5/2018</u>) <u>8/14/2019-2/12/2020</u>
	\$ <u>23,604.13</u>	+	\$ <u>TBD</u>

It shall be the responsibility of DISTRICT to notify SUPERINTENDENT of any change in district of residence or change in the IEP that would affect this contract.

IN WITNESS WHEREOF, the parties hereto have executed this agreement:

OXNARD SCHOOL DISTRICT

VENTURA COUNTY OFFICE OF EDUCATION

Signature (DOR Authorized Representative)

Lisa A. Franz

Accepted By: [Signature]

Special Education Authorized Representative

Title: Director, Purchasing

Approved By: _____

VCOE Business Services Authorized Representative

Date: _____

Date: _____

Estimated Cost \$ 23,604.13

Please submit **two** original copies Oxnard School District-Purchasing Department



AGREEMENT

For Paraeducator Performing Special Circumstance Services

This Agreement, effective **January 18, 2019** is made by and between the Ventura County Office of Education, hereinafter referred to as SUPERINTENDENT, and the **Oxnard School District**, hereinafter referred to as DISTRICT.

EG061410

1. This agreement pertains to providing exceptional service(s) for, [REDACTED] a Special Education pupil who is a resident of DISTRICT and currently attends **Triton School** a special education program operated by SUPERINTENDENT.
2. SUPERINTENDENT agrees to provide for the exceptional service(s) of such Special Education pupil as authorized by DISTRICT or its designee and agreed to by SUPERINTENDENT.
3. DISTRICT shall reimburse SUPERINTENDENT the actual cost of providing the exceptional service plus the state approved indirect cost rate of SUPERINTENDENT.

Authorized exceptional service(s) shall consist of **Paraeducator performing special circumstance educational support throughout the school day for 1944 minutes a week. ESY will be provided at 240 minutes a day.**

4. DISTRICT acknowledges that certain types of expenses will continue to accrue during periods of student's absence from school, including but not limited to salary and benefits of staff providing the exceptional service(s). DISTRICT further acknowledges that if the exceptional service(s) includes the service(s) of SUPERINTENDENT's employee(s), 45 days' notice is required to layoff an employee for lack of work. Therefore, in the event the student unexpectedly leaves SUPERINTENDENT's program, SUPERINTENDENT will make every attempt to re-assign any staff involved in providing the exceptional service(s); however, if that is not possible, DISTRICT will reimburse SUPERINTENDENT for expense incurred throughout the layoff notice period.
5. DISTRICT does hereby agree to defend, indemnify and hold harmless the SUPERINTENDENT, the Ventura County Board of Education, and its officers, and employees from any and all claims, demands, liabilities, expenses (including attorneys' fees and costs of defense) arising as a result of SUPERINTENDENT's obligations under this agreement. However, this indemnification shall not apply if it is ultimately adjudicated that such claim, demand, liability or expense arose out of the sole negligence of the SUPERINTENDENT.
6. The term of this contract shall begin **1/18/2019 (IEP date)** and continue thereafter on a continuing basis until the IEP of said student is modified or until student's district of residence changes.

FISCAL YEAR-based on IEP date:	CURRENT: 2018-2019	UPCOMING: 2019-2020
	1/18/2019-6-7/2019	(ESY: 7/1/2019-7/5/2019)
	(ESY: 6/10/2019-6/28/2019)	1/14/2019-1/17/2020
(including ESY, if applicable)	\$ 25,991.09	\$ TBD

It shall be the responsibility of DISTRICT to notify SUPERINTENDENT of any change in district of residence or change in the IEP that would affect this contract.

IN WITNESS WHEREOF, the parties hereto have executed this agreement:

OXNARD SCHOOL DISTRICT

VENTURA COUNTY OFFICE OF EDUCATION

Signature-DOR Authorized Representative
Lisa A. Franz

Accepted By: [Signature]
Special Education Authorized Representative

Title: Director, Purchasing

Approved By: _____
VCOE Business Services Authorized Representative

Date: _____

Date: _____

Estimated Cost \$ **25,991.09**

Please submit **two** original copies Oxnard School District-Purchasing Department



AGREEMENT

For Paraeducator Performing Special Circumstance Services

This Agreement, effective **January 24, 2019** is made by and between the Ventura County Office of Education, hereinafter referred to as SUPERINTENDENT, and the Oxnard School District, hereinafter referred to as DISTRICT.

RR103108

1. This agreement pertains to providing exceptional service(s) for, [REDACTED] a Special Education pupil who is a resident of DISTRICT and currently attends, Sunkist School a special education program operated by SUPERINTENDENT.
2. SUPERINTENDENT agrees to provide for the exceptional service(s) of such Special Education pupil as authorized by DISTRICT or its designee and agreed to by SUPERINTENDENT.
3. DISTRICT shall reimburse SUPERINTENDENT the actual cost of providing the exceptional service plus the state approved indirect cost rate of SUPERINTENDENT.

Authorized exceptional service(s) shall consist of Paraeducator performing special circumstance educational support through out the school day, 330 minutes a day. ESY will be provided at 240 minutes a day.

4. DISTRICT acknowledges that certain types of expenses will continue to accrue during periods of student's absence from school, including but not limited to salary and benefits of staff providing the exceptional service(s). DISTRICT further acknowledges that if the exceptional service(s) includes the service(s) of SUPERINTENDENT's employee(s), 45 days' notice is required to layoff an employee for lack of work. Therefore, in the event the student unexpectedly leaves SUPERINTENDENT's program, SUPERINTENDENT will make every attempt to re-assign any staff involved in providing the exceptional service(s); however, if that is not possible, DISTRICT will reimburse SUPERINTENDENT for expense incurred throughout the layoff notice period.
5. DISTRICT does hereby agree to defend, indemnify and hold harmless the SUPERINTENDENT, the Ventura County Board of Education, and its officers, and employees from any and all claims, demands, liabilities, expenses (including attorneys' fees and costs of defense) arising as a result of SUPERINTENDENT's obligations under this agreement. However, this indemnification shall not apply if it is ultimately adjudicated that such claim, demand, liability or expense arose out of the sole negligence of the SUPERINTENDENT.
6. The term of this contract shall begin 1/24/2019 (IEP date) and continue thereafter on a continuing basis until the IEP of said student is modified or until student's district of residence changes.

FISCAL YEAR-based on IEP date: (including ESY, if applicable)	CURRENT: <u>2018-2019</u> <u>12/4/2019-6/6/2019</u> (ESY: <u>6/10/2019-6/28/2019</u>)		UPCOMING: <u>2019-2020</u> (ESY: <u>7/1/2019-7/5/2019</u>) <u>8/14/2019-1/22/2020</u>
	\$ <u>21,527.28</u>	+	\$ <u>TBD</u>

It shall be the responsibility of DISTRICT to notify SUPERINTENDENT of any change in district of residence or change in the IEP that would affect this contract.

IN WITNESS WHEREOF, the parties hereto have executed this agreement:

OXNARD SCHOOL DISTRICT

VENTURA COUNTY OFFICE OF EDUCATION

Signature Lisa A. Franz

Accepted By: [Signature]
Special Education Authorized Representative

Title: Director, Purchasing

Approved By: _____
Business Services Authorized Representative

Date: _____

Date: _____

Estimated Cost \$ 21,527.28

OSD BOARD AGENDA ITEM

Name of Contributor: Dr. Anabolena DeGenna

Date of Meeting: 4/3/19

- Study Session: _____
Closed Session _____
A-1. Preliminary _____
A-II. Reports _____
B. Hearings _____
C. Consent Agenda _____
- Agreement Category:
____ Academic
____ Enrichment
X Special Education
____ Support Services
____ Personnel
____ Legal
____ Facilities
- D. Action Items _____
F. Board Policies 1st Reading _____ 2nd Reading _____

Ratification of Agreement #18-224 – Cynthia Z. Hansen (DeGenna/Sugden)

Cynthia Z. Hansen will provide educational therapy and language support services, as well as serve as an Independent Education Evaluator for the Special Education Services Department during the 2018-2019 academic year.

FISCAL IMPACT:

Not to exceed \$20,000.00 (per attached rate sheet) - Special Education Funds

RECOMMENDATION:

It is the recommendation of the Director, Special Education Services, and the Assistant Superintendent, Educational Services, that the Board of Trustees ratify Agreement #18-224 with Cynthia Z. Hansen.

ADDITIONAL MATERIAL(S):

Attached: Agreement #18-224, Cynthia Z. Hansen (13 Pages)
 Scope of Services (2 Pages)
 Fee Schedule (1 Page)
 Certificate of Insurance (1 Page)

OXNARD SCHOOL DISTRICT

Agreement #18-224

AGREEMENT FOR CONSULTANT SERVICES

This Agreement for Consultant Services (“Agreement”) is entered into as of this 3rd day of April, 2019 by and between the Oxnard School District (“District”) and Cynthia Z. Hansen (“Consultant”). District and Consultant are sometimes hereinafter individually referred to as “Party” and hereinafter collectively referred to as the “Parties.”

RECITALS

- A. District is authorized by *California Government Code* Section 53060, and Board Policy 4368, to contract with independent contractors for the furnishing of services concerning financial, economic, accounting, engineering, legal, administrative and other matters. District has sought, by issuance of a Request for Proposals or Invitation for Bids, the performance of the Services, as defined and described particularly on Exhibit A, attached to this Agreement.
- B. Following submission of a proposal or bid for the performance of the Services, Consultant was selected by the District to perform the Services.
- C. The Parties desire to formalize the selection of Consultant for performance of the Services and desire that the terms of that performance be as particularly defined and described herein.

OPERATIVE PROVISIONS

NOW, THEREFORE, in consideration of the mutual promises and covenants made by the Parties and contained here and other consideration, the value and adequacy of which are hereby acknowledged, the parties agree as follows:

- Incorporation of Recitals and Exhibits.** The Recitals set forth above and all exhibits attached to this Agreement, as hereafter amended, are incorporated by this reference as if fully set forth herein.
- Term of Agreement.** Subject to earlier termination as provided below, this Agreement shall remain in effect from January 17, 2019 through June 30, 2019 (the “Term”). This Agreement may be extended only by amendment, signed by the Parties, prior to the expiration of the Term.
- Time for Performance.** The scope of services set forth in Exhibit A shall be completed during the Term pursuant to the schedule specified Exhibit A. Should the scope of services not be completed pursuant to that schedule, the Consultant shall be deemed to be in Default as provided below. The District, in its sole discretion, may choose not to enforce the Default provisions of this Agreement and may instead allow Consultant to continue performing the Services.
- Compensation and Method of Payment.** Subject to any limitations set forth below or elsewhere in this Agreement, District agrees to pay Consultant the amounts specified in Exhibit B “Compensation”. The total compensation shall not exceed Twenty Thousand Dollars (\$20,000.00) per attached rate sheet, unless additional compensation is approved in writing by the District.

- a. Each month Consultant shall furnish to District an original invoice for all work performed and expenses incurred during the preceding month. The invoice shall detail charges by the following categories: labor (by sub-category), travel, materials, equipment, supplies, and sub-consultant contracts. Sub-consultant charges, if any, shall be detailed by the following categories: labor, travel, materials, equipment and supplies. District shall independently review each invoice submitted by the Consultant to determine whether the work performed and expenses incurred are in compliance with the provisions of this Agreement. In the event that no charges or expenses are disputed, the invoice shall be approved and paid according to the terms set forth in subsection b. In the event any charges or expenses are disputed by District, the original invoice shall be returned by District to Consultant for correction and resubmission.
- b. Except as to any charges for work performed or expenses incurred by Consultant which are disputed by District, District will use its best efforts to cause Consultant to be paid within forty-five (45) days of receipt of Consultant's correct and undisputed invoice.
- c. Payment to Consultant for work performed pursuant to this Agreement shall not be deemed to waive any defects in work performed by Consultant.

5. **Termination.** This Agreement may be terminated at any time by mutual agreement of the Parties or by either Party as follows:

- a. District may terminate this Agreement, with or without cause, at any time by giving thirty (30) days written notice of termination to Consultant. In the event such notice is given, Consultant shall cease immediately all work in progress; or
- b. Consultant may terminate this Agreement for cause at any time upon thirty (30) days written notice of termination to District.

6. **Inspection and Final Acceptance.** District may, at its discretion, inspect and accept or reject any of Consultant's work under this Agreement, either during performance or when within sixty (60) days after submitted to District. If District does not reject work by a timely written explanation, Consultant's work shall be deemed to have been accepted. District's acceptance shall be conclusive as to such work except with respect to latent defects, fraud and such gross mistakes as amount to fraud. Acceptance of any of Consultant's work by District shall not constitute a waiver of any of the provisions of this Agreement including, but not limited to indemnification and insurance provisions.

7. **Default.** Failure of Consultant to perform any Services or comply with any provisions of this Agreement may constitute a default. The District may give notice to Consultant of the default and the reasons for the default. District shall not have any obligation or duty to continue compensating Consultant for any work performed after the date of the notice until the default is cured. The notice shall include the timeframe in which Consultant may cure the default. This timeframe is presumptively thirty (30) days, but may be extended, though not reduced, at the discretion of the District. During the period of time that Consultant is in default, the District shall hold all invoices and shall, when the default is cured, proceed with payment on the invoices. In the alternative, the District may, in its sole discretion, elect to pay some or all of the outstanding invoices during the period of default. If Consultant does not cure the default, the District may terminate this Agreement as provided above. Any failure on the part of the District to give notice of the Consultant's default shall not be deemed to result in a waiver of the District's legal rights or any rights arising out of any provision of this Agreement.

8. **Ownership of Documents.** All maps, models, designs, drawings, photographs, studies, surveys, reports, data, notes, computer files, files and other documents prepared, developed or discovered by Consultant in the course of providing any services pursuant to this Agreement (collectively and individually, the "Documents") shall

become the sole property of District and may be used, reused or otherwise disposed of by District without the permission of the Consultant. Upon completion, expiration or termination of this Agreement, Consultant shall turn over to District all such Documents.

9. **Use of Documents by District.** If and to the extent that District utilizes for any purpose not related to this Agreement any Documents, Consultant's guarantees and warrants related to Standard of Performance under this Agreement shall not extend to such use of the Documents.

10. **Consultant's Books and Records.** Consultant shall maintain any and all documents and records demonstrating or relating to Consultant's performance of services pursuant to this Agreement for a minimum of three years after termination or expiration of this Agreement, or longer if required by law.

- a. Consultant shall maintain any and all ledgers, books of account, invoices, vouchers, canceled checks, or other documents or records evidencing or relating to work, services, expenditures and disbursements charged to District pursuant to this Agreement for a minimum of three years, or longer if required by law, all in accordance with generally accepted accounting principles and with sufficient detail so as to permit an accurate evaluation of the services provided by Consultant pursuant to this Agreement.
- b. Any and all such records or documents shall be made available for inspection, audit and copying, at any time during regular business hours, upon request by District or its designated representative. Copies of such documents or records shall be provided directly to the District for inspection, audit and copying when it is practical to do so; otherwise, unless an alternative is mutually agreed upon, such documents and records shall be made available at Consultant's address indicated for receipt of notices in this Agreement.
- c. District has the right to acquire custody of such records by written request if Consultant decides to dissolve or terminate its business. Consultant shall deliver or cause to be delivered all such records and documents to District within sixty (60) days of receipt of the request.

11. **Independent Contractor.** Consultant is and shall at all times remain a wholly independent contractor and not an officer, employee or agent of District.

- a. The personnel performing the services under this Agreement on behalf of Consultant shall at all times be under Consultant's exclusive direction and control. Consultant, its agents or employees shall not at any time or in any manner represent that Consultant or any of Consultant's officers, employees, or agents are in any manner officials, officers, employees or agents of District. Neither Consultant, nor any of Consultant's officers, employees or agents, shall, by virtue of services rendered under this Agreement, obtain any rights to retirement, health care or any other benefits which may otherwise accrue to District's employees. Consultant will be responsible for payment of all Consultant's employees' wages, payroll taxes, employee benefits and any amounts due for federal and state income taxes and Social Security taxes since these taxes will not be withheld from payment under this agreement.
- b. Consultant shall have no authority to bind District in any manner, or to incur any obligation, debt or liability of any kind on behalf of or against District, whether by contract or otherwise, unless such authority is expressly conferred in writing by District, or under this Agreement.

12. **Standard of Performance.** Consultant represents and warrants that it has the qualifications, experience and facilities necessary to properly perform the services required under this Agreement in a thorough, competent and professional manner. Consultant shall at all times faithfully, competently and to the best of its ability, experience and talent, perform all services described herein. In meeting its obligations under this Agreement,

Consultant shall employ, at a minimum, generally accepted standards and practices utilized by persons engaged in providing services similar to those required of Consultant under this Agreement.

13. **Confidential Information.** All information gained during performance of the Services and all Documents or other work product produced by Consultant in performance of this Agreement shall be considered confidential. Consultant shall not release or disclose any such information, Documents or work product to persons or entities other than District without prior written authorization from the Superintendent of the District, except as may be required by law.

- a. Consultant shall promptly notify District if it is served with any summons, complaint, subpoena or other discovery request, court order or other request from any party regarding this Agreement or the work performed hereunder.
- b. District retains the right, but has no obligation, to represent Consultant or be present at any deposition, hearing or similar proceeding. Consultant agrees to cooperate fully with District and to provide District with the opportunity to review any response to discovery requests provided by Consultant; provided that this does not imply or mean the right by District to control, direct, or rewrite said response.

14. **Conflict of Interest; Disclosure of Interest.** Consultant covenants that neither it, nor any officer or principal of its firm, has or shall acquire any interest, directly or indirectly, which would conflict in any manner with the interests of District or which would in any way hinder Consultant’s performance of services under this Agreement. Consultant further covenants that in the performance of this Agreement, no person having any such interest shall be employed by it as an officer, employee, agent or subcontractor without the express written consent of the District.

- a. Consultant agrees to at all times avoid conflicts of interest or the appearance of any conflicts of interest with the interests of District in the performance of this Agreement.
- b. Bylaws of the Board 9270 BB and 9270(BB) E, as hereinafter amended or renumbered, require that a Consultant that qualifies as a “designated employee” must disclose certain financial interests by filing financial interest disclosures. By its initials below, Consultant represents that it has received and reviewed a copy of the Bylaws of the Board 9270 BB and 9270(BB) E and that it [____] does [X] does not qualify as a “designated employee”.

_____ (Initials)

- c. Consultant agrees to notify the Superintendent, in writing, if Consultant believes that it is a “designate employee” and should be filing financial interest disclosures, but has not been required to do so by the District.

_____ (Initials)

15. **Compliance with Applicable Laws.** In connection with the Services and its operations, Consultant shall keep itself informed of and comply with all applicable federal, state and local laws, statutes, codes, ordinances, regulations and rules including, but not limited to, minimum wages and/or prohibitions against discrimination, in effect during the Term. Consultant shall obtain any and all licenses, permits and authorizations necessary to perform the Services. Neither District, nor any elected or appointed boards, officers, officials, employees or agents of District shall be liable, at law or in equity, as a result of any failure of Consultant to comply with this section.

- a. Without limiting the generality of the foregoing, Consultant shall comply with any applicable fingerprinting requirements as set forth in the Education Code of the State of California.

_____ (Initials)

16. **Unauthorized Aliens.** Consultant hereby promises and agrees to comply with all of the provisions of the Federal Immigration and Nationality Act, 8 U.S.C.A. §§ 1101, et seq., as amended, and in connection therewith, shall not employ “unauthorized aliens” as that term is defined in 8 U.S.C.A. §1324a(h)(3). Should Consultant so employ such individuals for the performance of work and/or services covered by this Agreement, and should any liability or sanctions be imposed against District for such employment, Consultant hereby agrees to and shall reimburse District for the cost of all such liabilities or sanctions imposed, together with any and all costs, including attorneys' fees, incurred by District.

17. **Non-Discrimination.** Consultant shall abide by the applicable provisions of the United States Civil Rights Act of 1964 and other provisions of law prohibiting discrimination and shall not discriminate, in any way, against any person on the basis of race, color, religious creed, national origin, ancestry, sex, age, physical handicap, medical condition or marital status in connection with or related to the performance of this Agreement.

18. **Assignment.** The expertise and experience of Consultant are material considerations for this Agreement. District has an interest in the qualifications of and capability of the persons and entities that will fulfill the duties and obligations imposed upon Consultant under this Agreement. In recognition of that interest, Consultant shall not assign or transfer this Agreement or any portion of this Agreement or the performance of any of Consultant’s duties or obligations under this Agreement without the prior written consent of the Board of Directors of the District. Any attempted assignment shall be ineffective, null and void, and shall constitute a material breach of this Agreement entitling District to any and all remedies at law or in equity, including summary termination of this Agreement.

19. **Subcontracting.** Notwithstanding the above, Consultant may utilize subcontractors in the performance of its duties pursuant to this Agreement, but only with the prior written consent of the District. The Consultant shall be as fully responsible to the District for the acts and omissions of his Subcontractors, and of persons either directly or indirectly employed by him/her, as if the acts and omissions were performed by him/her directly.

20. **Continuity of Personnel.** Consultant shall make every reasonable effort to maintain the stability and continuity of Consultant’s staff and subcontractors, if any, assigned to perform the services required under this Agreement.

- a. Consultant shall insure that District has a current list of all personnel and sub-contractors providing services under this Agreement.
- b. Consultant shall notify District of any changes in Consultant’s staff and subcontractors, if any, assigned to perform the services required under this Agreement, prior to and during any such performance. The list notice shall include the following information: (1) all full or part-time staff positions by title, including volunteer positions whose direct services are required to provide the services described herein; (2) a brief description of the functions of each such position and the hours each position works each week or, for part-time positions, each day or month, as appropriate; (3) the professional degree, if applicable, and experience required for each position; and (4) the name of the person responsible for fulfilling the terms of this Agreement.

21. **Indemnification.**

- a. Consultant agrees to defend, indemnify, and hold harmless District, its officers, agents, employees, and/or volunteers from any and all claims, demands, losses, damages and expenses, including legal fees and costs, or other obligations or claims arising out of any liability or damage to property, or any other loss, sustained or claimed to have been sustained arising out of activities of the Consultant or those of any of Consultant’s officers, agents, employees, or subcontractors, whether such act or omission is authorized by this Agreement or not. Consultant shall also pay for any and all damage to the Property of the District, or loss or theft of such Property, done or caused by such persons. District

assumes no responsibility whatsoever for any property placed on district premises. Consultant further agrees to waive all rights of subrogation against the District. The provisions of this Agreement do not apply to any damage or losses caused solely by the negligence of the District or any of its officers, agents, employees, and/or volunteers.

_____ (Initials)

- b. The provisions of this section do not apply to claims occurring as a result of District's sole negligence or willful acts or omissions.

22. **Insurance.** Consultant agrees to obtain and maintain in full force and effect during the term of this Agreement the insurance policies set forth in **Exhibit C** "Insurance" and made a part of this Agreement. All insurance policies shall be subject to approval by District as to form and content. These requirements are subject to amendment or waiver if so approved in writing by the District Superintendent. Consultant agrees to provide District with copies of required policies upon request.

23. **Notices.** All notices required or permitted to be given under this Agreement shall be in writing and shall be personally delivered, or sent by telecopier or certified mail, postage prepaid and return receipt requested, addressed as follows:

To District: Oxnard School District
 1051 South A Street
 Oxnard, California, 93030
 Attention: Amelia Sugden
 Phone: 805.385.1501, x2175
 Fax: 805.487.9648

To Consultant: Cynthia Z. Hansen, M.Ed., ET/P
 PO Box 7165
 Ventura, CA 93036
 Phone: 805.407.1742
 Email: cindyzhansen@gmail.com

Notice shall be deemed effective on the date personally delivered or transmitted by facsimile (provided confirmation of successful facsimile transmission shall be retained) or, if mailed, three (3) days after deposit of the same in the custody of the United States Postal Service.

24. **Excusable Delays.** Consultant shall not be liable for damages, including liquidated damages, if any, caused by delay in performance or failure to perform due to causes beyond the control of Consultant. Such causes include, but are not limited to, acts of God, acts of the public enemy, acts of federal, state or local governments, acts of District, court orders, fires, floods, epidemics, strikes, embargoes, and unusually severe weather. The term and price of this Agreement shall be equitably adjusted for any delays due to such causes.

25. **Authority to Execute.** The person or persons executing this Agreement on behalf of Consultant represents and warrants that he/she/they has/have the authority to so execute this Agreement and to bind Consultant to the performance of its obligations hereunder.

26. **Administration.** AMELIA SUGDEN shall be in charge of administering this Agreement on behalf of the District. The Director of Purchasing has completed **Exhibit D** "Conflict of Interest Check" attached hereto.

27. **Binding Effect.** This Agreement shall be binding upon the heirs, executors, administrators, successors and assigns of the parties.
28. **Entire Agreement.** This Agreement and the exhibits and documents incorporated herein constitute the entire agreement and understanding between the parties in connection with the matters covered herein.
29. **Amendment.** No amendment to or modification of this Agreement shall be valid or binding unless made in writing by the Consultant and by the District. The parties agree that this requirement for written modifications cannot be waived and that any attempted waiver shall be void.
30. **Waiver.** Waiver by any party to this Agreement of any term, condition, or covenant of this Agreement shall not constitute a waiver of any other term, condition, or covenant. Waiver by any party of any breach of the provisions of this Agreement shall not constitute a waiver of any other provision or a waiver of any subsequent breach or violation of any provision of this Agreement. Acceptance by District of any work or services by Consultant shall not constitute a waiver of any of the provisions of this Agreement.
31. **Governing Law.** This Agreement shall be interpreted, construed and governed according to the laws of the State of California. In the event of litigation between the parties, venue in state trial courts shall lie exclusively in the County of Ventura, California.
32. **Arbitration.** Any dispute arising out of the performance of this Agreement shall be resolved by binding arbitration in accordance with rules and procedures of the American Arbitration Association.
33. **Severability.** If any term, condition or covenant of this Agreement is declared or determined by any court of competent jurisdiction to be invalid, void or unenforceable, the remaining provisions of this Agreement shall not be affected thereby and the Agreement shall be read and construed without the invalid, void or unenforceable provision(s).

[THE REMAINDER OF THIS PAGE IS INTENTIONALLY LEFT BLANK]

IN WITNESS WHEREOF, the District and Consultant have executed and delivered this agreement for consultant services as of the date first written above.

OXNARD SCHOOL DISTRICT:

CYNTHIA Z. HANSEN, M.ED., ET/P:

Signature

Signature

Lisa A. Franz, Director, Purchasing

Typed Name/Title

Typed Name/Title

Date

Date

Tax Identification Number: 95-6002318

Tax Identification Number: _____

- Not Project Related
- Project #18-224

EXHIBIT A
TO AGREEMENT FOR CONSULTANT SERVICES #18-224

SERVICES

I. Consultant will perform the following Services under the Captioned Agreement:

***PER ATTACHED SCOPE OF SERVICES AND FEE SCHEDULE**

II. As part of the Services, Consultant will prepare and deliver the following tangible work products to the District:

***PER ATTACHED SCOPE OF SERVICES AND FEE SCHEDULE**

III. During performance of the Services, Consultant will keep the District appraised of the status of performance by delivering the following status reports under the indicated schedule:

STATUS REPORT FOR ACTIVITY:	DUE DATE
A. N/A	
B. N/A	
C. N/A	
D. N/A	

V. Consultant will utilize the following personnel to accomplish the Services:

- None.
- See attached list.

VI. Consultant will utilize the following subcontractors to accomplish the Services (check one):

- None.
- See attached list.

VII. AMENDMENT

The Scope of Services, including services, work product, and personnel, are subject to change by mutual Agreement. In the absence of mutual Agreement regarding the need to change any aspects of performance, Consultant shall comply with the Scope of Services as indicated above

- Not Project Related
 Project #18-224

EXHIBIT B
TO AGREEMENT FOR CONSULTANT SERVICES #18-224

COMPENSATION

I. Consultant shall use the following rates of pay in the performance of the Services:

Total compensation shall not exceed Twenty Thousand Dollars (\$20,000.00), per attached proposal/rate sheet, unless additional compensation is approved in writing by the District.

II. Consultant may utilize subcontractors as indicated in this Agreement. The hourly rate for any subcontractor is not to exceed \$ N/A per hour without written authorization from the District Superintendent or his designee.

III. The District will compensate Consultant for the Services performed upon submission of a valid invoice. Each invoice is to include:

- A. Line items for all personnel describing the work performed, the number of hours worked, and the Hourly or flat rate.
- B. Line items for all supplies properly charged to the Services.
- C. Line items for all travel properly charged to the Services.
- D. Line items for all equipment properly charged to the Services.
- E. Line items for all materials properly charged to the Services.
- F. Line items for all subcontractor labor, supplies, equipment, materials, and travel properly charged to the Services.

IV. The total compensation for the Services shall not exceed \$20,000.00, per attached proposal/rate sheet, as provided in Section 4 of this Agreement.

EXHIBIT C
TO AGREEMENT FOR CONSULTANT SERVICES #18-224

INSURANCE

I. **Insurance Requirements.** Consultant shall provide and maintain insurance, acceptable to the District Superintendent or District Counsel, in full force and effect throughout the term of this Agreement, against claims for injuries to persons or damages to property which may arise from or in connection with the performance of the work hereunder by Consultant, its agents, representatives or employees. Insurance is to be placed with insurers authorized to conduct business in the State of California and with a current A.M. Best's rating of no less than A, as rated by the Current edition of Best's Key Rating Guide, published by A.M. Best Company, Oldwick, New Jersey 08858. Consultant shall provide the following scope and limits of insurance:

A. **Minimum Scope of Insurance.** Coverage shall be at least as broad as:

(1) Commercial General Liability coverage of not less than two million dollars (\$2,000,000) Aggregate and one million dollars (\$1,000,000) per occurrence.

(2) Auto liability insurance with limits of not less than one million dollars (\$1,000,000).

(3) Insurance coverage should include:

1. owned, non-owned and hired vehicles;
2. blanket contractual;
3. broad form property damage;
4. products/completed operations; and
5. personal injury.

(4) Workers' Compensation insurance as required by the laws of the State of California.

(5) Abuse and Molestation coverage of not less than two million dollars (\$2,000,000) per occurrence and five million dollars (\$5,000,000) Aggregate.

(6) Professional liability (Errors and Omissions) insurance, including contractual liability, as appropriate to the Consultant's profession, in an amount of not less than the following:

Accountants, Attorneys, Education Consultants, Nurses, Therapists	\$1,000,000
Architects	\$1,000,000 or \$2,000,000
Physicians and Medical Corporations	\$5,000,000

Failure to maintain professional liability insurance is a material breach of this Agreement and grounds for immediate termination

II. **Other Provisions.** Insurance policies required by this Agreement shall contain the following provisions:

Not Project Related

Project #18-224

A. All Policies. Each insurance policy required by this Agreement shall be endorsed and state the coverage shall not be suspended, voided, cancelled by the insurer or either party to this Agreement, reduced in coverage or in limits except after 30 days' prior written notice by Certified mail, return receipt requested, has been given to District

B. General Liability, Automobile Liability, and Abuse/Molestation Coverages.

(1) District, and its respective elected and appointed officers, officials, employees and volunteers are to be covered as additional insureds (collectively, "additional insureds") as respects the following: liability arising out of activities Consultant performs; products and completed operations of Consultant; premises owned, occupied or used by Consultant ; automobiles owned, leased, hired or borrowed by Consultant, and Abuse/Molestation. The coverage shall contain no special limitations on the scope of protection afforded to additional insureds.

(2) Each policy shall state that the coverage provided is primary and any insurance carried by any additional insured is in excess to and non-contributory with Consultant's insurance.

(3) Consultant's insurance shall apply separately to each insured against whom claim is made or suit is brought, except with respect to the limits of the insurer's liability.

(4) Any failure to comply with the reporting or other provisions of the policies including breaches of warranties shall not affect coverage provided to any additional insured.

III. Other Requirements. Consultant agrees to deposit with District, at or before the effective date of this contract, certificates of insurance necessary to satisfy District that the insurance provisions of this contract have been complied with. The District may require that Consultant furnish District with copies of original endorsements effecting coverage required by this Section. The certificates and endorsements are to be signed by a person authorized by that insurer to bind coverage on its behalf. District reserves the right to inspect complete, certified copies of all required insurance policies, at any time.

A. If any Services are performed by subcontractor, Consultant shall furnish certificates and endorsements from each subcontractor identical to those Consultant provides.

B. Any deductibles or self-insured retentions must be declared to and approved by District. At the option of District, either the insurer shall reduce or eliminate such deductibles or self-insured retentions as respects District or its respective elected or appointed officers, officials, employees and volunteers or the Consultant shall procure a bond guaranteeing payment of losses and related investigations, claim administration, defense expenses and claims.

C. The procuring of any required policy or policies of insurance shall not be construed to limit Consultant's liability hereunder nor to fulfill the indemnification provisions and requirements of this Agreement.

- Not Project Related
- Project #18-224

EXHIBIT D
TO AGREEMENT FOR CONSULTANT SERVICES #18-224

CONFLICT OF INTEREST CHECK

Bylaws of the Board 9270(BB)E requires that the Superintendent or a designee make a determination, on a case by case basis, concerning whether disclosure will be required from a consultant to comply with the District's Conflict of Interest Code (commencing with Bylaws of the Board 9270 BB).

Consultant's are required to file disclosures when, pursuant to a contract with the District, the Consultant will make certain specified government decisions or will perform the same or substantially the same duties for the District as a staff person would.

The services to be performed by Consultant under the Agreement to which this Exhibit D is attached constitute do not constitute governmental decisions or staff services within the meaning of the Conflict of Interest Code. Therefore, the Consultant, **CYNTHIA Z. HANSEN, M.ED., ET/P** who will provide Services under the Agreement, is is not subject to disclosure obligations.

Date: _____

By: _____
Lisa A. Franz
Director, Purchasing



Scope of Services

The focus of the Cynthia Z. Hansen, M.Ed., ET/P Educational Therapist/Professional, Sole Proprietorship, is to support the families of Gifted and Talented students who have Specific Learning Disabilities or are failing to thrive without additional services. Additionally, Ms. Hansen also serves students with mild ASD, ADHD, and Dyslexia who may or may not show signs of giftedness. In this capacity, Ms Hansen leads family and educator workshops that inform communities about the characteristics of gifted and exceptional children with non traditional learning needs.

Following best practices as an expert on Gifted and Talented Education, Ms Hansen is a consultant and advisor when creating Individualized Service Plans, Individual Education Plans or 504 plans for students who need specific, systematic support to minimize the impact of their learning disabilities or differences within the educational environment. As an educational therapist, Ms. Hansen uses research-based methods specifically designed for a given disability or cluster of disabilities while simultaneously supporting the child in areas of high intellectual ability and performance.

Ms Hansen provides guidance to a child's support community, including parents, guardians, administrators and educators in order to understand the full range of supports needed for the child who:

- Has dual documentation of superior intellectual ability, while being unable to achieve to that potential due to one or more Specific Learning Disabilities
- Has documentation describing one or more Specific Learning Disabilities which mask a child's intellectual ability on school performance measures
- Has ADHD, executive dysfunctions or delays, dyslexia, mild ASD, and need additional services
- Has had difficulty receiving special education services due to their average/proficient performances on school and state measures of achievement.

Ms. Hansen's services include:

- Individual Educational Therapy providing intervention and support for students with Specific Learning Disabilities or learning differences while mentoring the social-emotional components of the learning process
- Providing guidance to students, families, school staff and allied professionals to understand the additional impact that a gifted profile adds to learning expectations and current progress
- Collaboration with parents, teachers and school staff in order to address the needs of the student and to develop appropriate and reasonable accommodations for the classroom
- Providing informational presentations to the community
- Providing professional development to school and support staff





Cynthia Z. Hansen, M.Ed., ET/P
Educational Therapist/Professional
Gifted & Talented Education Specialist

Biographical Background:

Cynthia Z Hansen's qualifications include three current Ryan Clear California Teaching Credentials, a Master of Education, Post Masters Certification in Gifted and Talented Education, and graduate level Special Education coursework (including assessment practices and implications; laws and practices; ethics of educational therapy practices). In addition, Ms. Hansen completed 1,500 supervised clinical hours required to attain Professional status in the Association of Educational Therapists. Prior to her work as an educational therapist, Ms. Hansen taught drama and English teacher at K-12 schools, a GATE enrichment teacher, a teacher librarian, and an Indian Education Teacher with the Ventura County Indian Education Consortium under Dr. Jerry Barshay.

Ms. Hansen is an award-winning teacher and has lead workshops locally and at national conferences such as *National Association for the Gifted*, *International Dyslexia Association*, *Council for Exceptional Children*, *Social-Emotional Needs of the Gifted*, and the *Association for Educational Therapists*.



Cynthia Z. Hansen, M.Ed., ET/P
AET Educational Therapist/Professional

www.CynthiaZHansen.com

(805) 407-1742 CindyZHansen@Gmail.com
P.O. Box 7165, Ventura 93006

For more information about educational therapy please visit: www.aetonline.org

(Rev. 2/13/19)

Cynthia Z. Hansen, M.Ed., ET/P

Educational Therapist/Professional
Gifted & Talented Education Specialist

Unmasking Challenges to Reveal Possibilities

Interventions & Strengths Development * Academic Enrichment * Family Support

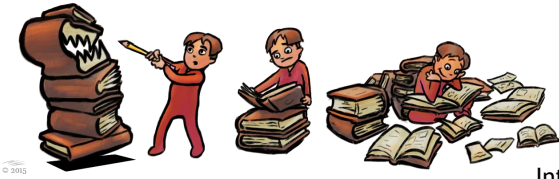

"Every worthwhile accomplishment, big or little, has its stages of drudgery and triumph; a beginning, a struggle, a victory." --Gandhi

Educational Therapy Fee Schedule

Fees for educational therapy sessions shall be paid at each session unless contracted otherwise. Statements will be mailed at the end of each month or given in person for your records. Additional Services (described below) incurred during the month will be billed monthly. **Educational therapy sessions are \$110/hour.**

Additional Services are \$110/hour and may include such activities as:

- A. Parent conferences (longer than 15 minutes)
- B. Meetings or calls with allied professionals working with your child (longer than 15 minutes)
- C. Educational assessments and report writing
- D. In person classroom observation, meetings with teachers, IEP or parent/teacher conferences
- E. Costs for travel per session (based on distance, \$15.00-\$50.00)

There is no charge for document review after the initial Intake Sessions or preparation of lesson plans.



Cynthia Z. Hansen, M.Ed., ET/P
Educational Therapist/Professional

www.CynthiaZHansen.com

(805) 407-1742 CindyZHansen@Gmail.com
P.O. Box 7165, Ventura 93006

For more information about educational therapy please visit: www.aetonline.org

(Rev. 2/13/19)



CERTIFICATE OF LIABILITY INSURANCE

DATE (MM/DD/YYYY)
02/15/2019

THIS CERTIFICATE IS ISSUED AS A MATTER OF INFORMATION ONLY AND CONFERS NO RIGHTS UPON THE CERTIFICATE HOLDER. THIS CERTIFICATE DOES NOT AFFIRMATIVELY OR NEGATIVELY AMEND, EXTEND OR ALTER THE COVERAGE AFFORDED BY THE POLICIES BELOW. THIS CERTIFICATE OF INSURANCE DOES NOT CONSTITUTE A CONTRACT BETWEEN THE ISSUING INSURER(S), AUTHORIZED REPRESENTATIVE OR PRODUCER, AND THE CERTIFICATE HOLDER.

IMPORTANT: If the certificate holder is an ADDITIONAL INSURED, the policy(ies) must be endorsed. If SUBROGATION IS WAIVED, subject to the terms and conditions of the policy, certain policies may require an endorsement. A statement on this certificate does not confer rights to the certificate holder in lieu of such endorsement(s).

PRODUCER Michael K Veseth CLU, ChFC 1730 S Victoria Ave, Ste 200 Ventura, CA 93003 	CONTACT NAME: Michael K Veseth PHONE (A/C, No, Ext): 805 642-8271 E-MAIL ADDRESS: mike@vesethinsurance.com		FAX (A/C, No): 805 983-3379
	INSURER(S) AFFORDING COVERAGE INSURER A : State Farm General Insurance Company		NAIC # 25151
INSURED HANSEN, CYNTHIA Z DBA CYNTHIA Z HANSEN M ED ET P 2715 PREBLE AVE VENTURA CA 93003-4613	INSURER B :		
	INSURER C :		
	INSURER D :		
	INSURER E :		
	INSURER F :		

COVERAGES **CERTIFICATE NUMBER:** **REVISION NUMBER:**

THIS IS TO CERTIFY THAT THE POLICIES OF INSURANCE LISTED BELOW HAVE BEEN ISSUED TO THE INSURED NAMED ABOVE FOR THE POLICY PERIOD INDICATED. NOTWITHSTANDING ANY REQUIREMENT, TERM OR CONDITION OF ANY CONTRACT OR OTHER DOCUMENT WITH RESPECT TO WHICH THIS CERTIFICATE MAY BE ISSUED OR MAY PERTAIN, THE INSURANCE AFFORDED BY THE POLICIES DESCRIBED HEREIN IS SUBJECT TO ALL THE TERMS, EXCLUSIONS AND CONDITIONS OF SUCH POLICIES. LIMITS SHOWN MAY HAVE BEEN REDUCED BY PAID CLAIMS.

INSR LTR	TYPE OF INSURANCE	ADDL INSR	SUBR WVD	POLICY NUMBER	POLICY EFF (MM/DD/YYYY)	POLICY EXP (MM/DD/YYYY)	LIMITS
A	GENERAL LIABILITY <input checked="" type="checkbox"/> COMMERCIAL GENERAL LIABILITY <input type="checkbox"/> CLAIMS-MADE <input type="checkbox"/> OCCUR GEN'L AGGREGATE LIMIT APPLIES PER: <input type="checkbox"/> POLICY <input type="checkbox"/> PRO-JECT <input type="checkbox"/> LOC	Y	N	90-EG-N244-1	11/09/2018	11/09/2019	EACH OCCURRENCE \$ 1,000,000 DAMAGE TO RENTED PREMISES (Ea occurrence) \$ 300,000 MED EXP (Any one person) \$ 5,000 PERSONAL & ADV INJURY \$ 1,000,000 GENERAL AGGREGATE \$ 2,000,000 PRODUCTS - COMP/OP AGG \$ 2,000,000 B-BUSN PROP \$ 5,000
	AUTOMOBILE LIABILITY <input type="checkbox"/> ANY AUTO <input type="checkbox"/> ALL OWNED AUTOS <input type="checkbox"/> SCHEDULED AUTOS <input type="checkbox"/> HIRED AUTOS <input type="checkbox"/> NON-OWNED AUTOS						COMBINED SINGLE LIMIT (Ea accident) \$ BODILY INJURY (Per person) \$ BODILY INJURY (Per accident) \$ PROPERTY DAMAGE (Per accident) \$ \$
	UMBRELLA LIAB <input type="checkbox"/> OCCUR EXCESS LIAB <input type="checkbox"/> CLAIMS-MADE DED RETENTION \$						EACH OCCURRENCE \$ AGGREGATE \$ \$
	WORKERS COMPENSATION AND EMPLOYERS' LIABILITY ANY PROPRIETOR/PARTNER/EXECUTIVE OFFICE/MEMBER EXCLUDED? (Mandatory in NH) If yes, describe under DESCRIPTION OF OPERATIONS below		N/A				<input type="checkbox"/> WC STATU-TORY LIMITS <input type="checkbox"/> OTH-ER E.L. EACH ACCIDENT \$ E.L. DISEASE - EA EMPLOYEE \$ E.L. DISEASE - POLICY LIMIT \$

DESCRIPTION OF OPERATIONS / LOCATIONS / VEHICLES (Attach ACORD 101, Additional Remarks Schedule, if more space is required)

Additional Insured and

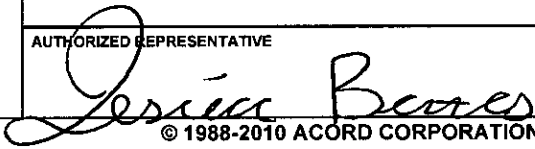
CERTIFICATE HOLDER Oxnard School District 1051 S A St Oxnard, CA 93030	CANCELLATION SHOULD ANY OF THE ABOVE DESCRIBED POLICIES BE CANCELLED BEFORE THE EXPIRATION DATE THEREOF, NOTICE WILL BE DELIVERED IN ACCORDANCE WITH THE POLICY PROVISIONS.
	AUTHORIZED REPRESENTATIVE 

BOARD AGENDA ITEM

Name of Contributor: Janet Penanhoat

Date of Meeting: 4/3/19

STUDY SESSION _____

CLOSED SESSION _____

SECTION A-1: PRELIMINARY _____

SECTION A-II: REPORTS _____

SECTION B: HEARINGS _____

SECTION C: CONSENT AGENDA _____

Agreement Category:

____ Academic

____ Enrichment

____ Special Education

____ Support Services

____ Personnel

____ Legal

X Facilities

SECTION D: ACTION _____

SECTION F: BOARD POLICIES 1st Reading _____ 2nd Reading _____

Ratification of Change Order No. 002 to Construction Services Agreement #17-117 with Bernards for the Marshall New Classroom Building Project (Penanhoat/Fateh/CFW)

Change Order No. 002 provides for the Board's consideration and ratification of four (4) change order requests. Two of these change orders were for unforeseen conditions that arose during construction. When project related work was done in the area, the school parking lot was found to be in need of seal coat and restriping (COR 38R1). An existing catchbasin was found to be in the area of the new play structure that is part of the project. The play structure needed to be moved and re-engineered (COR 78R1). COR 88 and 89R1 were district requests to enhance the performance of the technology system that is a part of the new building.

FISCAL IMPACT

Seventeen Thousand Four Hundred and Fifty Seven Dollars and No Cents (\$17,457.00) to be paid out of the Master Construct and Implementation Funds.

RECOMMENDATION

It is the recommendation of the Assistant Superintendent, Business & Fiscal Services, and the Director of Facilities, in conjunction with Caldwell Flores Winters, Inc. that the Board of Trustees ratify Change Order No. 002 to the Construction Services Agreement #17-117 with Bernards to provide Construction Services related to the Marshall New Classroom Building Project.

ADDITIONAL MATERIAL

Attached: Change Order No. 002 (2 Pages)
COR 38R1- Seal Coat and stripe parking lot (2 Pages)
COR 78R1- Playground Relocation (9 Pages)
COR 88-Add External WAPs (15 Pages)
COR 89R1- Add outlets in closets (14 Pages)
Construction Services Agreement #17-117 (115 pages)



CHANGE ORDER

Date: 4/3/2019

CHANGE ORDER NO. 002

PROJECT: MARSHALL NEW CLASSROOM BUILDING
O.S.D. BID No. N/A
O.S.D. Agreement No. 17-117

OWNER: Oxnard School District
 1051 South A Street
 Oxnard, CA. 93030

ARCHITECT CSDA Design Group
 4061 Glencoe Ave., Ste B
 Marina del Rey, CA 90292

CONTRACTOR:

Bernards
 555 First Street
 San Fernando, CA 91340
Attn: Mr. Rick Fochtman

Architects Proj. No.: 1534.01
D.S.A. File No.: 56-22
D.S.A. App. No.: 03-116806

CONFORMANCE WITH CONTRACT DOCUMENTS, PROJECT MANUAL, DRAWINGS AND SPECIFICATION. All Change Order work shall be in strict conformance with the Contract Documents, Project Manual, Drawings, and Specifications as they pertain to work of a similar nature.

ORIGINAL CONTRACT SUM.....	\$ 8,994,236.00
NET CHANGE - ALL PREVIOUS CHANGE ORDERS (001).....	\$ 88,128.00
ADJUSTED CONTRACT SUM.....	\$ 9,082,364.00
NET CHANGE -	\$ 17,457.00
<hr/>	
Total Change Orders to Date: 002.....	\$ 105,585.00
ADJUSTED CONTRACT SUM THROUGH CHANGE ORDER NO.: 002...	\$ 9,099,821.00
Commencement Date:	August 28, 2017
Original Completion Date:	October 31, 2018
Original Contract Time:	429 Calendar Days
Time Extension for all Previous Change Orders:	Zero Calendar Days
Time Extension for this Change Order:	Zero Days
Adjusted Completion Date:	October 31, 2018
Percentage	(1.17%)

Item	Description	Unforeseen Condition (UFO)	Additional Scope (AS)	Design Clarification (DC)	Code Requirement
1.	COR 38R1- Seal Coat and stripe parking lot	\$ 5581.00			
2.	COR 78R1- Playground Relocation	\$ 3255.00			
3.	COR 88-Add External WAPs		\$ 1645.00		
4.	COR 89R1- Add outlets in closets		\$ 6976.00		
	Totals	\$ 8,836.00	\$8,621.00		

Total Change Order No. 002\$ 17,457.00

**NOT VALID UNTIL SIGNED BY THE ARCHITECT, CONTRACTOR AND ASSIST.. SUPT. BUSINESS SERVICES OR PURCHASING DIRECTOR*

APPROVAL (REQUIRED):

ARCHITECT: _____

DATE: _____

CONTRACTOR: _____

DATE: _____

RECOMMENDED FOR APPROVAL:

OSD DSA INSPECTOR: _____

DATE: _____

ASST. SUPERINTENDENT, BUSINESS & FISCAL SERVICES

DATE: _____

APPROVAL (REQUIRED):

BOARD APPROVAL

DATE: _____

ASSIST. SUPT./PURCHASING DIRECTOR: _____

DATE: _____

DSA APPROVAL

DATE: _____



CHANGE ORDER REQUEST

Project: Marshall Elementary - New 6-8 Classroom Bldg.

COR No. 38 R1

Date: 7/25/2018

DESCRIPTION OF WORK

RFI 231 Provide seal coat and striping to entire parking lot. District liability 50% of costs incurred

SUMMARY OF COSTS

Item Description	Company	Amount Requested
Subcontract Costs		
	Onyx Paving Co Inc	5,143
	Subtotal:	5,143
Contractual Costs		
Sub Default Insurance		62
CCIP		65
Bond		45
Fee		266
	Subtotal:	438
Total Change Order Request Amount		5,581

APPROVAL

(Please note that if this Change Order Request is not approved by 8/08/2018, additional costs and schedule impacts may result.)

Oxnard School District

Bernards Bros. Inc.

Signature

Printed Name & Title

Date

Rebecca Miller
Signature

Rebecca Miller Project Manager
Printed Name & Title

2/8/19
Date

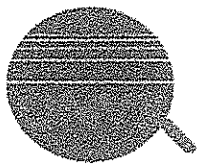

ONYX PAVING COMPANY, INC.
 2890 E. LA CRESTA AVE. ~ ANAHEIM, CA 92806
 714/ 632-6699 ~ FAX: 714/ 632-1883
 CA LIC #630360-A * D.I.R. #1000004798

BERNARDS, INC.
 555 First Street
 San Fernando, CA 91340

818/ 898-1521
 818/ 898-4909

ATTN: SAHITHYA MAVILLAPALLI

Smavillapalli@bernards.com

MARSHAL E.S. NEW GRADE 6-8 CLASSROOM BUILDING ~ 2900 Thurgood Marshall Dr, Oxnard

"Proposal is strictly based and relies upon Contractor's status as a Non-Union Contractor.

This Proposal is not valid if this project is Union, A PLA, or PSA, or you are a Union Contractor."

CHANGE ORDER

SEAL COAT NORTHEAST PARKING LOT APPROX. 40,723 SQ. FT.
 (2 COATS, 1 MOVE) AND RE-STRIP PER EXISTING LAYOUT INCLUDING CURB PAINTING.

TOTAL: \$10,285.00

Rod Webber

7/23/2018

ROD WEBBER

rodw@onyxpaving.net

ALL MATERIAL QUOTED IS SUBJECT TO PRICE ESCALATION BASED UPON THE CURRENT PRICE OF ASPHALT/ROCK BASE. ANY APPLICABLE MATERIAL PRICE INCREASE BEYOND THE "VALID THROUGH" DATE WILL BE ADDED TO THE BASE RATE PER TON OF THE MATERIAL TYPE QUOTED.
 EXCLUSIONS: Unless Specifically Noted Above - SUBGRADE TO BE MINIMUM +/- 0.10' OR TO REQUIRED PERCENTAGE BY OTHERS. SUBGRADE PREPARATION, SCARIFICATION, FINE GRADING OR COMPACTION, ENGINEERING, STAKING, SURVEYING, TESTING OR INSPECTIONS, WATER, WATER METERS OR FLOOD TESTING, SAWCUTTING, REMOVALS, COLD PLANING, IMPORT/EXPORT OF FILL MATERIALS, COST OF DISPOSAL OF MATERIALS IF PETROMAT IS FOUND UNDER EXISTING PAVEMENT, REMOVE OF EXCESS SOIL BELOW, ADJUSTING OF VALVES, MANHOLES OR UTILITIES AND PATCHING FOR SAME, TRENCH PATCHING OR PATCHING FOR OTHER TRADES, PRIME COAT, FOG SEAL, SEAL COAT, STRIPING, SIGNAGE, BUMPERS, FIRE DEPARTMENT STRIPING, BLACK OUT EXISTING STRIPING AND CRACK FILLERS, NOT RESPONSIBLE FOR DAMAGE TO NEWLY PLACED SEAL COAT CAUSED BY POWER STEERING, TIRE SCUFFING OR IRRIGATION RUN-OFF, CORING OF CONCRETE FOR INSTALLATION OF SIGNPOSTS, OFFSITE WORK, TEMPORARY STRIPING AND CAT TRACKING, TRAFFIC CONTROL, ROCK BASE UNDER ASPHALT/CONCRETE AND CONCRETE WORK, HEADER BOARD, CLEANING OF PAVEMENT OTHER THAN WITH POWER BLOWERS, PERMITS, BONDS, PREVAILING WAGE RATES AND FEES, PRICE EXCLUDES NIGHTTIME WEEKEND OR HOLIDAY WORKS UNLESS OTHERWISE NOTED, WEEDKILL, TRUNCATED DOMES, PROJECT LABOR AGREEMENTS.

ONYX PAVING CO., INC.

(Project Manager)

ACCEPTANCE (By Owner, Agent, or General Contractor)

COMPANY _____

BY _____

DATE _____



CHANGE ORDER REQUEST

Project: Marshall Elementary - New 6-8 Classroom Bldg.

COR No. 78 R1

Date: 12/31/2018

DESCRIPTION OF WORK

Relocation of play ground

SUMMARY OF COSTS

Item Description	Company	Amount Requested
Subcontract Costs		
Playground equipment location, there are irrigation controller valve and gas line connections. We were directed to move the location of the equipment to 10 feet south of existing location.	Sam Hill & Sons Inc	3,000
	Subtotal:	3,000
Contractual Costs		
Sub Default Insurance		36
CCIP		38
Bond		26
Fee		155
	Subtotal:	255
Total Change Order Request Amount		3,255

APPROVAL

(Please note that if this Change Order Request is not approved by 1/14/2019, additional costs and schedule impacts may result.)

Oxnard School District

Bernards Bros. Inc.

Signature

José ALVAREZ CCDA
Printed Name & Title

1-29-19
Date

Signature

Rebecca Miller Project Manager
Printed Name & Title

1/29/19
Date



P.O. BOX 5670
 VENTURA, CA 93005
 License No. 648594

Phone: (805) 644-6278
 Fax: (805) 644-2813
 Website: samhillsandsons.com

REQUEST FOR CHANGE ORDER (RFC): 9

Date: 05/12/18

Contract Number: 1641.001

Customer: Bernards

Project Name: Marshall School Oxnard

SH&S Job Number: 4597.17

	ITEM	QUANTITY	UNIT	UNIT PRICE	SUBTOTAL
1	EWT# 4597050218	1	LS	\$ 2,999.64	\$ 2,999.64
2					
3					\$ -
4					\$ -
5					\$ -

TOTAL FOR THIS REQUEST FOR CHANGE: \$ 2,999.64

Reason for Change: This RFC is for paving performed at the direction of Bernards. Equipment hours have been reduced per Steve Moreno, which amounts to a \$266.00 credit.

Submitted By: Steve Moreno

Date: 5/12/2018

Approved By:

Date:

GRANITE - BRIGGS ROAD FACILITY

Weighed at: 999 Mission Rock Rd.

Santa Paula, Ca 93060

805 879-6032

ORIGINAL

5/2/2018

10:27:11AM

Ticket No 29068691

Customer: 320419 - SAM HILL & SONS INC

Order: 193361 - FOB PLANT PICK UP

Job/PO#: GEORGE

Cost Code

Job Loc: 999 MISSION ROCK RD

Job # 4597

Comments:

Truck No: SHDT135 - SAM HILL 135

License: 42426M1 | |

Hauler

Driver In Vehicle

Product: 3583

3/8" FINE PG64-10

90-10
EWT # 4597050218

	Pounds	Metric Tons	Tons
Gross	21,040		10.52
Tare	16,000		8.00
Net	5,040	2.29	2.82
Scale:	1		

This Load:	2.52 TONS	Load No:	1
Shipped:	2.52 TONS		

Arrive Job	AM
Finish Unload	AM PM

Accepted by:

Weighmaster Granite Construction Company

Deputy TOMMY REAL

WEIGHMASTER CERTIFICATE

THIS IS TO CERTIFY that the following load was weighed and reported by a duly licensed and bonded professional weighmaster who is a recognized authority in accordance with Chapter 7 (commencing with Section 44000) of the California Professional Code, and with the provisions of the California Department of Food and Agriculture.

WARNING: THIS PRODUCT IS NOT TO BE USED FOR THE PURPOSES OF CALIFORNIA TO OBTAIN WEIGHTS FOR THE PURPOSES OF THE CALIFORNIA



INVOICE

SM

PLEASE MAIL REMITTANCE TO:
 Granite Construction Company
 PO Box 742476
 Los Angeles, CA 90074-2476

INVOICE DATE: 5/2/2018

SAM HILL & SONS INC
 PO BOX 5670
 ATTN RONALD L HILL - PRESIDENT
 VENTURA CA 93005-0670

ORDER NO.	CUSTOMER NO.	PLANT	INVOICE#
193361	320419	VENTURA AC 207835-100239	1381680
ORIGINAL INVOICE		#JOB ADDRESS	DATE OF SALE
		FOB PLANT PICK UP 999 MISSIONROCK RD SANTA PAULA CA 93060	5/2/2018
			PO# 42035768

A LATE PENALTY OF 1.5% WILL BE APPLIED ON PAST DUE BALANCES MONTHLY.

PAGE 1

TICKET NUMBER	TICKET DATE	MATERIAL DESCRIPTION	QTY	UNIT PRICE	EXTENDED AMOUNT	FOB	
29068691	5/2/2018	3/8"FINEPG64-10 (3583)	2.5200	60.0000	151.20	P	V051110000
	TOTAL:	3/8"FINEPG64-10 (3583)	2.5200	TN	151.20		
		ENVIRONMENTAL FEE (1947)	1.0000	LD	5.00		

90-10
 V
 6248 # 4597
 ENT 4597050218

TERMS: NET 30

The prevailing party shall be entitled to reasonable attorney's fees and costs in any action to collect the amounts due hereunder.

Note: If haul charges are indicated separately above, then the title passage of materials is at the plant, with delivery provided for customers.

For any question regarding this billing, please call (831)768-4002.

TOTAL FREIGHT	0.00
MATERIAL	151.20
FEES	5.00
SALES TAX	11.32

INVOICE TOTAL
167.52

FOB: P - PLANT	J - JOB	* - FOR OFFICIAL USE ONLY
<i>Thank You for your business.</i>		
<small>WARNING THIS PRODUCT CONTAINS A CHEMICAL KNOWN TO THE STATE OF CALIFORNIA TO CAUSE CANCER, BIRTH DEFECTS OR OTHER REPRODUCTIVE HARM. MSDS SHEETS AVAILABLE AT WWW.GRANITECONSTRUCTION.COM/MSDS OR BY CONTACTING YOUR LOCAL OFFICE.</small>		

SHIP TO:
FOB/ INBOUND
OXNARD BLVD
FOB SATICOY ASPHALT*
FOB SATICOY
OXNARD, CA 93036

SOLO TO:
SAM HILL & SONS
PO BOX 5670
VENTURA, CA 93005

INVOICE

CUSTOMER NO: 99087-219055
INVOICE NO: 71515137
INVOICE DATE: 07/12/2017
INVOICE AMT: 45.58
ORDER: 6155
DUE DATE: 08/15/2017

To ensure proper credit, please include remittance or list invoice numbers on your check remittance and send to:
Calmat Co dba Vulcan Materials Co
Lockbox 5572
Los Angeles, CA 90074-5572, US
Phone: 1-800-777-8752 or
help@vmcmail.com

INVOICES NOT PAID ACCORDING TO OUR CREDIT TERMS WILL BE ASSESSED A FINANCE CHARGE. CUSTOMER SHALL PAY ALL COST OF COLLECTION INCLUDING BUT NOT LIMITED TO A REASONABLE ATTORNEY'S FEE FOR SERVICES RENDERED BY SUIT OR OTHERWISE IN COLLECTING PAST DUE INVOICES.		TAXES CALIFORNIA VENTURA		PERCENT 6.00% 1.25%		AMOUNT 2.55 0.53		SALES TAX 3.08		TOTAL PRODUCT: 42.50		Pay this AMOUNT: \$45.58		
TOTAL QUANTITY: 1.00		TOTAL LOADS: 1.00		SALES REP: 11712 Rush Leavitt		PO NUMBER: 4550		REF: 6155		CONTRACT NO:		TERMS: NET 15TH PROX. - Payable in full by the 15th of each month following month of shipment		
INVOICE #	INVOICE DATE	CUSTOMER NUMBER	LOCATION	ORDER	LOCATION	ORDER	REF	BILL OF LADING		TAX EXEMPT ID		FOB		
71515137	07/12/2017	99087-219055	4984-231	6155	SATICOY HMA	6155	6155					PICKUP		
SHIP DATE	TICKET	VEHICLE	CLASS	PROD CODE	DESCRIPTION	UOM	QTY	PRICE	UOM	QTY	PRICE	UOM	QTY	
07/10/2017	115408552	86	STANDARD	9E0200	SS1H4.5 GAL BUCKET	E	1.00	42.50						
<p style="text-align: center;">TICKET DETAIL</p> <p style="font-size: 2em; font-weight: bold; text-align: center;">V305 / # 4550</p> <p style="font-size: 2em; font-weight: bold; text-align: center;">ENT 4550 67 10 17</p>													AMOUNT	42.50
<p style="text-align: center;">ADDED CHARGES</p>													PRICE	
<p style="text-align: center;">FRIGHT</p>													QTY	
<p style="text-align: center;">PRICE</p>													UOM	
<p style="text-align: center;">AMOUNT</p>													PRICE	42.50
<p style="text-align: center;">AMOUNT</p>													QTY	42.50

Receive your invoice faster and help save the environment by enrolling in our email invoicing service. With email, invoices are sent in one easy to open file directly to your inbox. To sign up, contact us at help@vmcmail.com or call us at 1-800-777-8752.

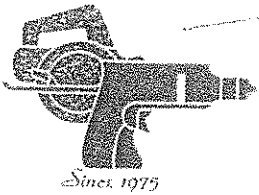

BUENA Tool co.

433 Laguna St. Santa Barbara, Ca. 93101
 Phone 805-963-3885
 www.buena-tool.com

Tool Repair - We Service What We Sell

Phone Orders & Delivery Available

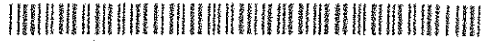

Buena Means Good... Good Quality, Service and Selection.

SOLD TO

SAM HILL & SONS
 PO BOX 5670

SHIP TO

MUST CALL OFFICE FOR
 AUTHORIZATION & JOB NAME
 ***** 644-6278 *****

VENTURA, CA 93005

It is expressly agreed that full title shall remain with seller until full amount is paid.

Terms: All Past Due amounts are subject to an interest charge of 1 1/2% per month which is equal to an annual rate of 18%.

ACCOUNT #	CUSTOMER P.O.#	TERMS	ORDER #	ORDER DATE	SLSMN	INVOICE #	INVOICE DATE
S1075		NET 27TH	80500	02/09/17	OS1	44753	02/13/17
ORDERED	BACKORDERED	SHIPPED	U/M	DESCRIPTION	PRICE	AMOUNT	
3	0	3	EA	PAINT BLUE MARKING CONST & SURVEY 20 OZ. 9041 00203 [609]	4.300	12.90*	
5	0	5	EA	PAINT FLOU. ORG MARKING CONST & SURVEY 20 OZ. 00222 [609]	3.700/EA	18.50*	
2	0	2	EA	TWINE 1LB PINK MASON WEL44373 [121]	8.000	16.00*	
1	0	1	6E	OIL 2 CYCLE 2.6OZ MIX W/1GAL 25140 2CYCLE [1025]	10.200	10.20*	
12	0	12	PR	GLOVE KNIT BLK NITRIL PALM XL 500NFT-10 RWG13XL [316]	2.750	33.00*	
12	0	12	EA	BROOM LOBBY 467 [331]	4.850	58.20*	5.23
5	0	5	EA	BLADE ABR 4-1/2X3/32X7/8 MET TYPE # 1 *** 23599 **** *****	3.550	17.75*	
1	0	1	10E	4121878 [515] BLADE ABR 14X20 MAS HAND HELD *** 37842 **** *****	67.000/10E	67.00*	
1	0	1	EA	141820MAS [1398] BLADE DMND DRY 14X1/20 COMBO 160617	180.000	180.00*	
5	0	5	EA	DBSP14 [1115] BLADE RECIP 8X10TH BULK OSB810R [1517]	3.390	16.95*	
					MERCHANDISE		
***** * INVOICE * *****					OTHER		
					TAX		
					FREIGHT		
					TOTAL		

OFFICE COPY

PLEASE BRING THIS INVOICE WITH ANY RETURNED ITEMS

SHIP VIA 275 # STOCK
 G 60230

OPERATED EQUIPMENT RATES

Effective 06/01/17 thru 06/30/18

Cat 336 Excavator	\$ 267.00	per hour
Cat 330 Excavator	\$ 242.00	per hour
Compaction Wheel (330)	\$ 42.00	per hour
Cat 321 Excavator	\$ 205.00	per hour
Compaction Wheel (321)	\$ 40.00	per hour
Cat 314 Offset Excavator	\$ 182.00	per hour
Compaction Wheel (314)	\$ 38.00	per hour
Bobcat 430 Excavator	\$ 145.00	per hour
Case 590 / John Deere 310 Extendahoe (Backhoe/Loader)	\$ 145.00	per hour
Compaction Wheel (for Extendahoe/Backhoe)	\$ 22.00	per hour
Extendahoe w/Paving Box	\$ 175.00	per hour
Extendahoe w/Allied Hoe-Pak	\$ 165.00	per hour
Extendahoe w/Auger	\$ 165.00	per hour
Extendahoe w/Hy-Ram	\$ 217.00	per hour
Extendahoe & Bobtail Dump Truck Combo (1 operator)	\$ 165.00	per hour
Extendahoe & 10 Wheel Dump Truck Combo (1 operator)	\$ 177.00	per hour
Uniloader Bobcat with Hoe or Loader	\$ 145.00	per hour
Uniloader Bobcat with Hy-Ram	\$ 180.00	per hour
Uniloader Bobcat with Cold Planer/Asphalt Grinder	\$ 189.00	per hour
John Deere 650H Dozer w/Slope board	\$ 160.00	per hour
Cat 950G Loader (4 cu.yd.)	\$ 179.00	per hour
Cat 930K Loader (side dump)	\$ 170.00	per hour
Cat 112F Motorgrader	\$ 131.00	per hour
Hansen End Dump	\$ 123.00	per hour
50 Ton Lowbed (move-on/off)	\$ 128.00	per hour
50 Ton Lowbed (Green Load)	\$ 133.00	per hour
50 Ton Lowbed (Bonus Purple)	\$ 139.00	per hour
Permit	\$ 90.00	each way
2000 Gallon Water Truck	\$ 123.00	per hour
Gang Truck w/Tools	\$ 47.00	per hour
Foreman	\$ 99.00	per hour
Operator	\$ 92.00	per hour
Laborer	\$ 79.00	per hour

* - Hourly labor and equipment rentals are subject to a four (4) hour minimum.

** - Equipment rates subject to a fuel surcharge in the event of surging fuel prices.

*** - Standard rental rates will apply to the first eight (8) hours of each day. After

eight (8) hours, **overtime will apply** as follows:

Operators	\$ 38.00	per hour
Laborers	\$ 33.00	per hour

BARE RENTAL EQUIPMENT RATES

Effective 06/01/17 thru 06/30/18

Cat 336 Excavator	\$ 1,400.00	daily
Cat 330 Excavator	\$ 1,200.00	daily
Compaction Wheel (330)	\$ 320.00	daily
Cat 321 Excavator	\$ 904.00	daily
Compaction Wheel (321)	\$ 304.00	daily
Cat 314 Excavator	\$ 720.00	daily
Compaction Wheel (314)	\$ 288.00	daily
Bobcat 430 Excavator	\$ 424.00	daily
Case 590 / John Deere 310 Extindahoe	\$ 424.00	daily
Compaction Wheel (for Extindahoe/Backhoe)	\$ 160.00	daily
Unloader Bobcat	\$ 424.00	daily
John Deere 650H Dozer w/Slope board	\$ 544.00	daily
Cat 950G Loader (4 cu.yd.)	\$ 696.00	daily
Cat 930K Loader (side dump)	\$ 624.00	daily
Cat 112F Motorgrader	\$ 312.00	daily
Static Sheepsfoot	\$ 200.00	daily
Asphalt Roller (3 ton)	\$ 280.00	daily
Asphalt Roller (Double Drum Walk Behind)	\$ 240.00	daily
Cat R-80 8,000lb Forklift	\$ 280.00	daily
Dump Truck (6 cu.yd.) plus fuel	\$ 320.00	daily
Dump Truck (10 Wheeler) plus fuel	\$ 400.00	daily
Dump Trailer	\$ 80.00	daily
2000 Gallon Water Truck	\$ 360.00	daily
500 Gallon Water Pull Tank (Water Buffalo)	\$ 144.00	daily
Air Compressor with Tools	\$ 240.00	daily
Pierce Arrow Pneumatic Mole (Pneuma-Gopher)	\$ 300.00	daily
Lincoln 200 Amp Arc Welder (plus gas)	\$ 160.00	daily
2500 Generator	\$ 50.00	daily
3" Pump w/Suction hose & 25' Discharge hose	\$ 80.00	daily
Vibratory Plate	\$ 144.00	daily
Jumping Jack Compactor (Whacker)	\$ 144.00	daily
Arrow Board	\$ 120.00	daily
Light Tower	\$ 110.00	daily
Manhole Blower	\$ 50.00	daily
Oxygen/Gas Tester (for confined space entry)	\$ 75.00	daily
Hepa Vacuum (Silica Law)	\$ 200.00	daily
Tri-pod w/Wench & Harness	\$ 150.00	daily
Roto Hammer	\$ 40.00	daily
Diamond Blade (Power saw concrete cutting)	\$ 50.00	each
Sewer Cleaning Rope Reel	\$ 20.00	daily

* - All equipment subject to move on and move off rates.

** - Jobs requiring 40-hour certificates for hazardous waste are subject to a rate change.

*** - Rates include all applicable taxes, overhead and profit.

**** - Equipment rates subject to a fuel surcharge in the event of surging fuel prices.



CHANGE ORDER REQUEST

COR No. 88 R0

Date: 12/25/2018

Project: Marshall Elementary - New 6-8 Classroom Bldg.

DESCRIPTION OF WORK

RFI 305 add external WAP's

SUMMARY OF COSTS

Item Description	Company	Amount Requested
Subcontract Costs		
Per RFI 305 add external WAP's	Taft Electric Co	1,517
	Subtotal:	1,517
Contractual Costs		
Sub Default Insurance		18
CCIP		19
Bond		13
Fee		78
	Subtotal:	128
Total Change Order Request Amount		1,645

APPROVAL

(Please note that if this Change Order Request is not approved by 1/14/2019, additional costs and schedule impacts may result.)

Oxnard School District

Bernards Bros. Inc.

Jennifer McDone
Signature

Rebecca Miller
Signature

Jennifer McDone, Project Mgr
Printed Name & Title

Rebecca Miller, Project Manager
Printed Name & Title

1/21/19
Date

1/19/19
Date

ACCEPTED - JM_011619



CHANGE ORDER REQUEST

Project: Marshall Elementary - New 6-8 Classroom Bldg.

COR No. 88 R0

Date: 12/25/2018

DESCRIPTION OF WORK

RFI 305 add external WAP's

SUMMARY OF COSTS

Item Description	Company	Amount Requested
Subcontract Costs		
Per RFI 305 add external WAP's	Taft Electric Co	1,517
	Subtotal:	1,517
Contractual Costs		
Sub Default Insurance		18
CCIP		19
Bond		13
Fee		78
	Subtotal:	128
Total Change Order Request Amount		1,645

APPROVAL

(Please note that if this Change Order Request is not approved by 1/14/2019, additional costs and schedule impacts may result.)

Oxnard School District

Bernards Bros. Inc.

Signature

Rebecca Miller

Signature

Printed Name & Title

Rebecca Miller, Project Manager

Printed Name & Title

Date

1/19/19

Date

ACCEPTED - JM_011619



Taft Electric
1694 Eastman Avenue
Ventura, California 93003
Phone: (805) 642-0121

Project: 2258 - Marshall ES
2900 Thurgood Marshall Dr, Oxnard, CA 93036
Oxnard, California 93036
Phone: 8056547994
Fax: 8056547994

Change Order Request #008: Exterior WAPs

TO:	Bernards 555 1st St San Fernando, California, 91340	FROM:	Taft Electric Company 1694 Eastman Avenue Ventura California, 93003
PCO NUMBER/REVISION:	008 / 0	CONTRACT:	1 - Marshall ES Prime Contract
REQUEST RECEIVED FROM:		CREATED BY:	Matt Gobuty (Taft Electric Company)
STATUS:	Pending - In Review	CREATED DATE:	12/7 /2018
REFERENCE:		FIELD CHANGE:	No
SCHEDULE IMPACT:		LOCATION:	
		TOTAL AMOUNT:	\$1,517.00

POTENTIAL CHANGE ORDER TITLE: Exterior WAPs

CHANGE REASON: RFI Directive

POTENTIAL CHANGE ORDER DESCRIPTION: *(The Contract Is Changed As Follows)*

We are submitting the above cost for the additional work required as directed in RFI 305:
-Rough in and install wireless access points
-WAP devices provided by owner, installed by Taft/Pacificom

This change proposal is based on the usual cost elements such as labor, materials and markup and does not include any amount for impacts such as interference, trade stacking, disruptions, rescheduling, changes in the sequence of work, delays and or associated acceleration. We expressly reserve our right to submit our request for any of these items should we be faced with performing work under any of these conditions.

This cost proposal supersedes all previously submitted cost proposals relating to this same work. The work of other trades which may be required to complete this change order is not part of this proposal
This quote is valid for 30 calendar days from the above date. We reserve our right to re-quote this proposal should the approval take longer than 30 days.

Attached is the back up for your review. Please call should you have any questions.

General Exclusions

- Any weather proofing or sealing of exterior penetrations for water intrusion.
- Any shift work, holiday work, or overtime labor, all work is to be performed during normal working hrs Monday-Friday between 7AM & 3:30PM
- Any and all parts and labor not specifically listed above.
- Any permits or fees.
- Any costs associated with the design, engineering (including wet stamps), or approval process. Any access panels.

ATTACHMENTS:

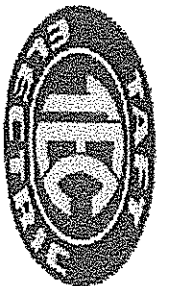

ID: 2258
 fact: Marshall ES COR

Takeoff

Job: TAFT Labor Level: TAFT 5 Dec 2018 15:28:55

Item: WABS

Item #	Qty	U/M	Q/M	Size	Description	Material Unit	Material Result	Labor Unit	Labor Result
150040	2.00	EA	M	2-1/8"D. 30.3-CL	4"SQ 3/4-KO NO BRKT	4.6828	9.37	0.4500	0.90
6	2.00		M		4S/5S BOX SUPPCKT	5.4999	11.00	0.3750	0.75
150064	2.00	EA	M	1-1/2"RISE 11.3-CL	1G 4"SQ PLASTER-RING	4.3784	8.76	0.2250	0.45
160573	24.00	EA	M	#10 X 1"	TEK SCREW	0.0196	0.47	0.0240	0.58
6	4.00		M		1-HOOK	8.6400	34.56	0.0850	0.34
9	4.00		M	1/4"	STIFFY HANGER	2.2500	9.00	0.1350	0.54
7	2.00		M		FIREBLOK GASKET	7.3900	14.78	0.1250	0.25
10047	10.00	FT	M	3/4	EMT	0.8275	8.27	0.0500	0.50
10207	2.00	EA	M	3/4	EMT STEEL SS IMS-THROAT CONNECTOR	0.4422	0.88	0.1000	0.20
40174	2.00	EA	M	1 1/4	PLASTIC BUSHING	0.6327	1.67	0.2000	0.40
Phase Totals:						98.76	98.76	4.91	4.91
Job Totals:						98.76	98.76	4.91	4.91

Electronic Company 1694 Gardner Avenue Phone: 805-642-0121
 Ventura, CA 93003 Web: www.takellectric.com

PacificCom

Pacific Coast Sound and Communications
 330 N. Wood Road, Suite L • Camarillo, CA 93010
 (805) 987-1351 • (805) 647-2823 • Fax (805) 987-1353
 www.pacificomusa.com • License #529914 (C7/C10)

CHANGE ORDER PROPOSAL

Taft Electric Company

ATTENTION: Matt Gobuty

Thurgood Marshall Elementary School - New Classroom Building

Purchase order # 2258

Sales order # 5304

10/22/18

DESCRIPTION:		RFI 305 - Added exterior WAP's			
MATERIAL ADD					
QTY	PART NUMBER	MANUFACTURER	DESCRIPTION	UNIT COST	EXTENDED COST
4	HXJ6B	Hubbell	NEXTSPEED® Category 6 Jack, Universal, Blue	\$7.03	\$28.12
360	3613	Belden	Cable, Category 6	\$0.63	\$225.00
				\$0.00	\$0.00
				\$0.00	\$0.00
				\$0.00	\$0.00
TOTAL ADD PRICE					\$253.12

MATERIAL DEDUCT					
QTY	PART NUMBER	MFG	DESCRIPTION	UNIT COST	EXTENDED COST
					\$0.00
					\$0.00
					\$0.00
					\$0.00
TOTAL DEDUCT PRICE					\$0.00

LABOR CHARGES					
DATE	INSTALLER	HOURS	LABOR RATE	EXTENDED COST	
		4	\$75.00	\$300.00	
				\$0.00	
				\$0.00	
				\$0.00	
TOTAL LABOR PRICE				\$300.00	

MATERIALS COSTS	ADD	\$253.12	
	DEDUCT	\$0.00	
	TOTAL ADD/DEDUCTS	\$253.12	
MATERIALS PRICE FOR PROJECT	TOTAL COST OF MATERIALS	\$253.12	
	TOTAL MARKED UP MATERIALS	\$291.09	7.25%
	SALES TAX	\$21.10	
MARK UP AND LABOR COSTS	FREIGHT	\$5.82	2%
	LABOR COST	\$300.00	
	PROFIT & OVERHEAD LABOR	\$45.00	
	TOTAL LABOR	\$345.00	15%

TOTAL CHANGE ORDER AMOUNT: \$663.01

With payment to be made as follows: Based on original contract.

EXCEPTIONS THAT MAY APPLY:

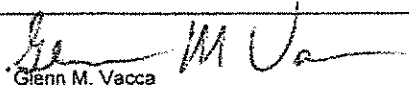
Authorized Signature: 
 Glenn M. Vacca
 Taft Electric Company

This proposal may be withdrawn by us if not accepted with in 15 days.

DATE: _____

CONTRACTOR

Acceptance of Proposal - The above prices, specifications, and conditions are satisfactory and are hereby accepted. You are authorized to do the work as specified. Payment will be made as outlined above.

All material is guaranteed to be as specified. All work is to be completed in a workmanlike manner according to standard practices. I agree to be contingent upon strikes, accidents or delays beyond our control. Our workers are fully covered.



**REQUEST FOR INFORMATION
FOR SUBCONTRACTOR ACTION**

RFI No. : 305

Project: Marshall Elementary - New 6-8 Classroom Bldg.

Date: 10-18-18
Discipline: Electrical

Subject: Added Exterior WAP's

DRAWING & SPECIFICATION REFERENCES

Drawing Sheet / Specification	Detail / Sub Section	Comments
E-203		

QUESTION

Per meeting with District on 10/18/18, District requested for two Exterior WAPs. Please confirm the addition of two exterior wireless access points as shown in the attached sketch. They will be installed at the same elevation as the exterior speakers

If the location & elevation indicated is unacceptable, please provide new locations/elevations?

ANSWER

Response:

The locations are acceptable with TREEEOR if OK with the District.
Mount at min. of 80" AFF. (typ. to speakers ht. and FA)

Response provided by Jose Arche, CSDA on 10-18-2018

RESPONSE DISTRIBUTION

Company	Contact	Date Sent
Taft Electric Co	Matt Gobuty	10/19/2018

Please review and advise Bernards, WITHIN 7 days, if there are any additional costs or schedule impacts associated with incorporating the RFI response with the Contract Work. (Include a brief description and rough order estimate of the change with this notification. If no response is received within 7 days, Bernards shall trust that there is no impact to your Contract Price or Schedule.

Question Initiated By: Matt Gobuty - Taft Electric Co - Author Number: 47
Submitted By: Matt Gobuty - Taft Electric Co



REQUEST FOR INFORMATION

RFI No.: 305

To: Jose Arche

Date: 10-18-18

Company: CSDA Design Group

Discipline: Electrical

Project: Marshall Elementary - New 6-8 Classroom Bldg.

Subject: Added Exterior WAP's

Response Requested By: 10-25-2018

DRAWINGS & SPECIFICATION REFERENCES

Drawing Sheet / Specification	Detail / Sub Section	Comments
E-203		

QUESTION

Per meeting with District on 10/18/18, District requested for two Exterior WAPs. Please confirm the addition of two exterior wireless access points as shown in the attached sketch. They will be installed at the same elevation as the exterior speakers

If the location & elevation indicated is unacceptable, please provide new locations/elevations?

ANSWER

The locations are acceptable with TREI-EEOR if OK with the District.
Mount at min. of 80" AFF. (typ. to speakers ht. and FA)

Response Provided By:

Name

Jose Arche, CSDA

Company

10-18-18

Date

Question Initiated By: Matt Gobuty - Taft Electric Co - Author Number: 47

Submitted By: Matt Gobuty - Taft Electric Co

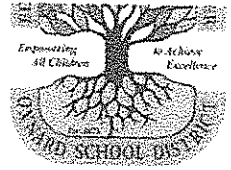

PROJECT OWNER:
OXNARD SCHOOL DISTRICT

1051 E. A Street
 OXNARD, CA 93030
 805.487.3918

www.oxnardsd.org

PROJECT NAME:
MARSHALL NEW CLASSROOM BUILDING

2900 Thurgood Marshall Dr.
 Oxnard, CA 93036

KEY PLAN:

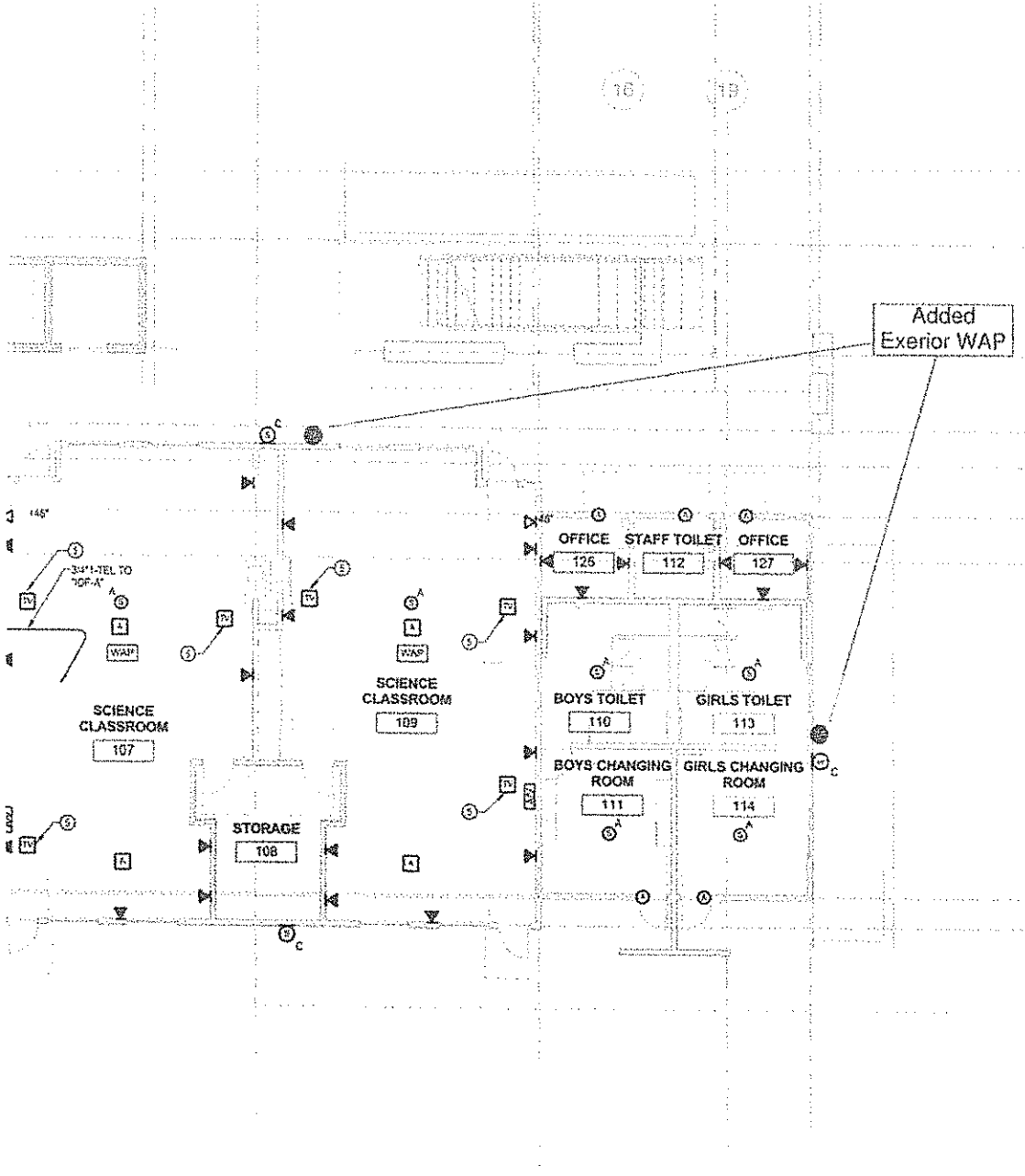

NO.	ISSUES/REVISIONS	DATE
1	DESIGN DEV.	10/23/11
2	100% CD SUBMITTAL	12/08/11
3	DSA SUBMITTAL	01/28/12
4	CCD #23	04/09/12

ORIGINAL SCALE:

 PROJECT NO.: TRE1 #15644
 SHEET TITLE:

FIRST FLOOR PLAN - SIGNAL

SHEET NO.:
E-203

REVISED TV AND TV WALL RACK LOCATIONS TO MEET CURRENT DISTRICT REQUIREMENTS, INCLUDING DEDICATED POWER RECEPTACLES.

- ELECTRICAL NOTES**
1. SHOW INSTANTANEOUS SHORT-CIRCUIT CURRENT CAPACITY (SCCC) FOR ALL ELECTRICAL EQUIPMENT.
 2. ALL ELECTRICAL EQUIPMENT SHALL BE INSTALLED IN ACCORDANCE WITH THE NATIONAL ELECTRICAL CODE (NEC).
 3. ALL ELECTRICAL EQUIPMENT SHALL BE INSTALLED IN ACCORDANCE WITH THE NATIONAL FIRE ALARM AND SIGNALING CODE (NFPA 72).
 4. ALL ELECTRICAL EQUIPMENT SHALL BE INSTALLED IN ACCORDANCE WITH THE NATIONAL ELECTRICAL CODE (NEC) AND THE NATIONAL FIRE ALARM AND SIGNALING CODE (NFPA 72).
 5. ALL ELECTRICAL EQUIPMENT SHALL BE INSTALLED IN ACCORDANCE WITH THE NATIONAL ELECTRICAL CODE (NEC) AND THE NATIONAL FIRE ALARM AND SIGNALING CODE (NFPA 72).
 6. ALL ELECTRICAL EQUIPMENT SHALL BE INSTALLED IN ACCORDANCE WITH THE NATIONAL ELECTRICAL CODE (NEC) AND THE NATIONAL FIRE ALARM AND SIGNALING CODE (NFPA 72).
 7. ALL ELECTRICAL EQUIPMENT SHALL BE INSTALLED IN ACCORDANCE WITH THE NATIONAL ELECTRICAL CODE (NEC) AND THE NATIONAL FIRE ALARM AND SIGNALING CODE (NFPA 72).
 8. ALL ELECTRICAL EQUIPMENT SHALL BE INSTALLED IN ACCORDANCE WITH THE NATIONAL ELECTRICAL CODE (NEC) AND THE NATIONAL FIRE ALARM AND SIGNALING CODE (NFPA 72).
 9. ALL ELECTRICAL EQUIPMENT SHALL BE INSTALLED IN ACCORDANCE WITH THE NATIONAL ELECTRICAL CODE (NEC) AND THE NATIONAL FIRE ALARM AND SIGNALING CODE (NFPA 72).

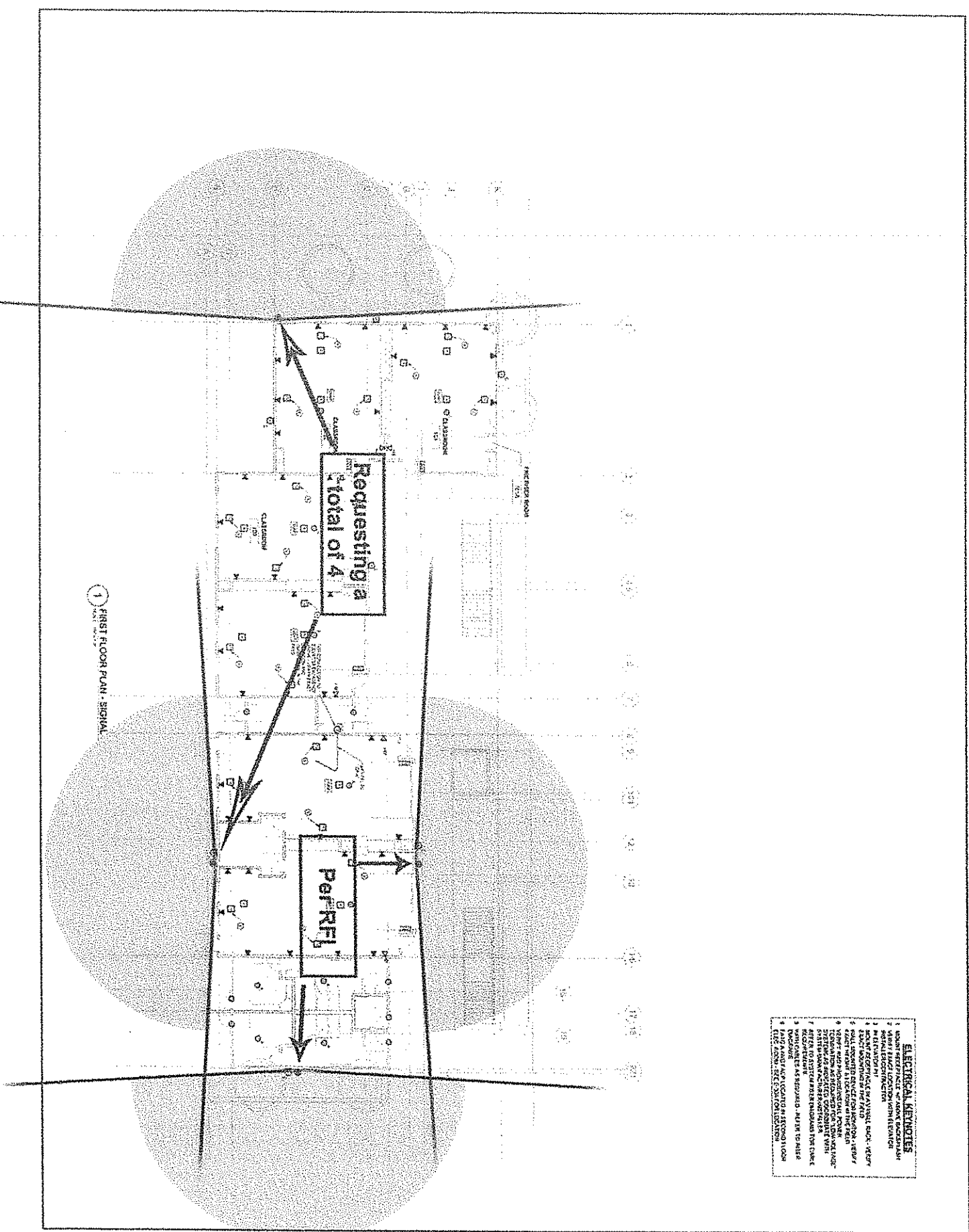

1 FIRST FLOOR PLAN - SIGNAL

CSDA DESIGN
12345 Main Street
San Diego, CA 92101
Tel: (619) 555-1234
Fax: (619) 555-5678
www.csdadesign.com

OWAYD SCHOOL DISTRICT
12345 Main Street
San Diego, CA 92101
Tel: (619) 555-1234
Fax: (619) 555-5678
www.owaydschools.org

E-203

TAFT ELECTRIC CO.
LABOR BURDEN REPORT
Period of July 30, 2018 to December 30, 2018

	JOURNEYMAN				FOREMAN				GEN. FOREMAN			
	St. Time	1.5 Time	2 Time		St. Time	1.5 Time	2 Time		St. Time	1.5 Time	2 Time	
VENTURA COUNTY LOCAL 952												
WAGES	\$ 39.08	\$ 58.62	\$ 78.16		\$ 43.50	\$ 65.24	\$ 86.99		\$ 47.91	\$ 71.87	\$ 95.82	
HEALTH & WELFARE	\$ 8.18	\$ 8.18	\$ 8.18		\$ 8.18	\$ 8.18	\$ 8.18		\$ 8.18	\$ 8.18	\$ 8.18	
LOCAL PENSION	16.64	24.96	33.28		16.64	24.96	33.28		16.64	24.96	33.28	
TRAINING FUND	1.00	1.00	1.00		1.00	1.00	1.00		1.00	1.00	1.00	
LMCC	0.50	0.50	0.50		0.50	0.50	0.50		0.50	0.50	0.50	
N.E.I.F. (1%)	0.39	0.59	0.78		0.43	0.65	0.87		0.48	0.72	0.96	
NAT. PENSION (3%)	1.17	1.76	2.34		1.30	1.96	2.61		1.44	2.16	2.87	
UNION BURDEN	\$ 27.88	\$ 36.98	\$ 46.09		\$ 28.06	\$ 37.25	\$ 46.44		\$ 28.24	\$ 37.51	\$ 46.79	
F.I.C.A. (7.65%)	\$ 2.99	\$ 4.48	\$ 5.98		\$ 3.33	\$ 4.99	\$ 6.65		\$ 3.67	\$ 5.50	\$ 7.33	
F.U.I. (0.8%)	0.31	0.47	0.63		0.35	0.52	0.70		0.38	0.57	0.77	
S.U.I. (6.2%)	2.42	3.63	4.85		2.70	4.05	5.39		2.97	4.46	5.94	
TAX BURDEN	\$ 5.73	\$ 8.59	\$ 11.45		\$ 6.37	\$ 9.56	\$ 12.74		\$ 7.02	\$ 10.53	\$ 14.04	
LIABILITY INSURANCE	5.4%	\$ 2.11	\$ 3.17	\$ 4.22	\$ 2.35	\$ 3.52	\$ 4.70	\$ 2.59	\$ 3.88	\$ 5.17	\$ 6.46	
WORKMAN'S COMP		1.05	1.05	1.05	1.17	1.17	1.17	1.29	1.29	1.29	1.29	
INSURANCE BURDEN	\$ 3.16	\$ 4.22	\$ 5.27		\$ 3.52	\$ 4.69	\$ 5.87		\$ 3.88	\$ 5.17	\$ 6.46	
DIRECT COST PER HOUR	\$ 75.85	\$ 108.41	\$ 140.97		\$ 81.45	\$ 116.75	\$ 152.05		\$ 87.05	\$ 125.08	\$ 163.12	
DIRECT COST PER DAY	\$ 606.81		\$ 65.12		\$ 651.59		\$ 70.60		\$ 696.36		\$ 76.07	
DIRECT COST PER WEEK	\$ 3,034.05		\$ 3,257.93		\$ 3,481.81							

NOTES:
WORKMAN'S COMP RATES: LESS THAN \$32.00/HOUR = 5.658%
WORKMAN'S COMP RATES: GREATER THAN \$32.00/HOUR = 2.693%

TAFT ELECTRIC CO.

Labor Rate

Jan 1 thru July 30 2018

VENTURA COUNTY
LOCAL 952

JOURNEYMAN

FOREMAN

GEN. FOREMAN

	St. Time	1.5 Time	2 Time	St. Time	1.5 Time	2 Time	St. Time	1.5 Time	2 Time
Direct Cost p/ hour	\$75.85	\$108.41	\$140.97	\$81.45	\$116.75	\$152.05	\$87.05	\$125.08	\$163.12
Small Tools	0%	\$0.00	\$0.00	\$0.00	\$0.00	\$0.00	\$0.00	\$0.00	\$0.00
Safety	2.5%	\$1.90	\$1.90	\$1.90	\$1.90	\$1.90	\$1.90	\$1.90	\$1.90
Clean Up	3.0%	\$2.28	\$2.28	\$2.28	\$2.28	\$2.28	\$2.28	\$2.28	\$2.28
Totals	\$80.02	\$112.58	\$145.14	\$85.62	\$120.92	\$156.22	\$91.22	\$129.25	\$167.29
Mark Up	0.0%	\$0.00	\$0.00	\$0.00	\$0.00	\$0.00	\$0.00	\$0.00	\$0.00
Total	\$80.02	\$112.58	\$145.14	\$85.62	\$120.92	\$156.22	\$91.22	\$129.25	\$167.29

TAFT ELECTRIC CHANGE REQUEST PROPOSAL

LABOR RATE CALCULATIONS

PROJECT: Elm School Reconstruction JOB# 2551 TEC CR#: 0
 CUST RFP#: 0

STRAIGHT TIME CALCULATIONS

CLASS	HOURS	RATE
G. FOREMAN	0.00	\$0.00
FOREMAN	1.00	\$85.62
JOURNEYMAN	2.00	\$80.02
APPRENTICE	1.00	\$72.59
	0.00	\$0.00
	0.00	\$0.00
	0.00	\$0.00
	0.00	\$0.00
	0.00	\$0.00
	0.00	\$0.00
COMPOSITE RATE		\$79.56

SHIFT WORK CALCULATIONS

CLASS	HOURS	RATE
G. FOREMAN	0.00	\$74.93
FOREMAN	0.00	\$69.80
JOURNEYMAN	0.00	\$64.65
APPRENTICE	0.00	\$53.56
	0.00	\$0.00
	0.00	\$0.00
	0.00	\$0.00
	0.00	\$0.00
	0.00	\$0.00
	0.00	\$0.00
COMPOSITE RATE		\$0.00

OVERTIME CALCULATIONS

CLASS	HOURS	RATE
G. FOREMAN	0.00	\$87.83
FOREMAN	0.00	\$92.70
JOURNEYMAN	0.00	\$85.40
APPRENTICE	0.00	\$74.65
	0.00	\$0.00
	0.00	\$0.00
	0.00	\$0.00
	0.00	\$0.00
	0.00	\$0.00
	0.00	\$0.00
COMPOSITE RATE		\$0.00

GRAVEYARD CALCULATIONS

CLASS	HOURS	RATE
G. FOREMAN	0.00	\$87.83
FOREMAN	0.00	\$92.70
JOURNEYMAN	0.00	\$85.40
APPRENTICE	0.00	\$74.65
	0.00	\$0.00
	0.00	\$0.00
	0.00	\$0.00
	0.00	\$0.00
	0.00	\$0.00
	0.00	\$0.00
COMPOSITE RATE		\$0.00

DOUBLE TIME CALCULATIONS

CLASS	HOURS	RATE
G. FOREMAN	0.00	\$109.30
FOREMAN	0.00	\$115.60
JOURNEYMAN	0.00	\$106.15
APPRENTICE	0.00	\$89.95
	0.00	\$0.00
	0.00	\$0.00
	0.00	\$0.00
	0.00	\$0.00
	0.00	\$0.00
	0.00	\$0.00
COMPOSITE RATE		\$0.00

OTHER CALCULATIONS

CLASS	HOURS	RATE
G. FOREMAN	0.00	\$109.30
FOREMAN	0.00	\$115.60
JOURNEYMAN	0.00	\$106.15
APPRENTICE	0.00	\$89.95
	0.00	\$0.00
	0.00	\$0.00
	0.00	\$0.00
	0.00	\$0.00
	0.00	\$0.00
	0.00	\$0.00
COMPOSITE RATE		\$0.00

* THE ABOVE RATES ARE IN EFFECT UNTIL 9/25/2005

TAFT ELECTRIC COMPANY
LABOR BURDEN REPORT
Period of July 30, 2018 to December 30, 2018

VENTURA COUNTY
LOCAL 952
APPRENTICES - Indentured after 10/01/2012

	40%	45%	50%	60%	70%	85%												
WAGES	\$ 15.63	\$ 23.46	\$ 17.59	\$ 26.38	\$ 19.54	\$ 29.31	\$ 23.45	\$ 35.17	\$ 27.36	\$ 41.03	\$ 33.22	\$ 49.83						
HEALTH & WELFARE	\$ 0.18	\$ 0.18	\$ 0.18	\$ 0.18	\$ 0.18	\$ 0.18	\$ 0.18	\$ 0.18	\$ 0.18	\$ 0.18	\$ 0.18	\$ 0.18						
LOCAL PENSION	-	-	-	-	16.64	24.96	16.64	24.96	16.64	24.96	16.64	24.96						
TRAINING FUND	1.00	1.00	1.00	1.00	1.00	1.00	1.00	1.00	1.00	1.00	1.00	1.00						
LMCC	-	-	-	-	0.50	0.50	0.50	0.50	0.50	0.50	0.50	0.50						
NAT. PENSION (3%)	0.47	0.70	0.53	0.79	0.59	0.88	0.70	1.06	0.82	1.23	1.00	1.49						
N.E.L.F. (1%)	0.16	0.23	0.18	0.26	0.20	0.29	0.23	0.35	0.27	0.41	0.33	0.50						
UNION BURDEN	\$ 9.01	\$ 10.12	\$ 9.88	\$ 10.24	\$ 27.10	\$ 35.81	\$ 27.26	\$ 36.05	\$ 27.41	\$ 36.28	\$ 27.65	\$ 36.53						
F.I.C.A. (7.65%)	\$ 1.20	\$ 1.79	\$ 1.35	\$ 2.02	\$ 1.49	\$ 2.24	\$ 1.79	\$ 2.69	\$ 2.09	\$ 3.14	\$ 2.54	\$ 3.81						
F.U.I. (8%)	0.13	0.19	0.14	0.21	0.16	0.23	0.19	0.28	0.22	0.33	0.27	0.40						
S.U.I. (6.2%)	0.97	1.45	1.09	1.64	1.21	1.82	1.45	2.18	1.70	2.54	2.05	3.09						
TAX BURDEN	\$ 2.29	\$ 3.44	\$ 2.50	\$ 3.86	\$ 2.96	\$ 4.29	\$ 3.44	\$ 5.15	\$ 4.01	\$ 6.01	\$ 4.87	\$ 7.30						
LIABILITY INSURANC	6.4%	\$ 0.84	\$ 1.27	\$ 0.95	\$ 1.42	\$ 1.06	\$ 1.58	\$ 1.27	\$ 1.90	\$ 1.48	\$ 2.22	\$ 1.79	\$ 2.69					
WORKMAN'S COMP	0.88	0.88	1.00	1.00	1.11	1.11	1.33	1.33	1.55	1.55	0.89	0.89						
INSURANCE BURDEN	\$ 1.73	\$ 2.15	\$ 1.94	\$ 2.42	\$ 2.16	\$ 2.69	\$ 2.59	\$ 3.23	\$ 3.03	\$ 3.76	\$ 2.69	\$ 3.59						
DIRECT COST PER HOUR	\$ 29.48	\$ 39.15	\$ 9.70	\$ 31.99	\$ 42.90	\$ 10.91	\$ 51.66	\$ 72.10	\$ 20.44	\$ 56.73	\$ 79.60	\$ 22.86	\$ 61.80	\$ 87.09	\$ 25.29	\$ 68.42	\$ 97.34	\$ 28.92
DIRECT COST PER DAY	\$ 236.85	\$ 313.21	\$ 205.92	\$ 343.19	\$ 413.32	\$ 576.84	\$ 453.87	\$ 484.42	\$ 494.42	\$ 547.37	\$ 547.37	\$ 547.37						
DIRECT COST PER WEEK	\$ 1,178.24	\$ 1,566.07	\$ 1,278.62	\$ 1,715.93	\$ 2,066.60	\$ 2,884.19	\$ 2,269.36	\$ 2,472.12	\$ 2,472.12	\$ 2,736.86	\$ 2,736.86	\$ 2,736.86						

NOTES:
WORKMAN'S COMP RATES: LESS THAN \$32.00/HOUR = 5.658%
WORKMAN'S COMP RATES: GREATER THAN \$32.00/HOUR = 2.693%



CHANGE ORDER REQUEST

COR No. 89 R1

Date: 12/31/2018

Project: Marshall Elementary - New 6-8 Classroom Bldg.

DESCRIPTION OF WORK

RFI 318 add outlets in closets

SUMMARY OF COSTS

Item Description	Company	Amount Requested
Subcontract Costs		
RFI 318 add power outlets in closets, Per job walk regarding the AV systems, District requested that there be data and power outlets added to the closets for charging of the Teachers units.	Taft Electric Co	6,430
	Subtotal:	6,430
Contractual Costs		
Sub Default Insurance		77
CCIP		81
Bond		56
Fee		332
	Subtotal:	546
Total Change Order Request Amount		6,976

APPROVAL

(Please note that if this Change Order Request is not approved by 1/14/2019, additional costs and schedule impacts may result.)

Oxnard School District

Bernards Bros. Inc.

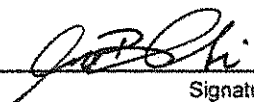

 Signature
 jose arche, CSDA

 Printed Name & Title
 02-05-2019

 Date

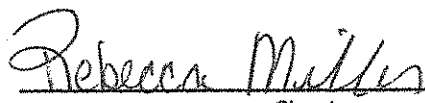

 Signature
 Rebecca Miller, Project Manager

 Printed Name & Title
 2/8/19

 Date



Taft Electric
1694 Eastman Avenue
Ventura, California 93003
Phone: (805) 642-0121

Project: 2258 - Marshall ES
2900 Thurgood Marshall Dr, Oxnard, CA 93036
Oxnard, California 93036
Phone: 8056547994
Fax: 8056547994

Change Order Request #009: Closet Power Outlets

TO:	Bernards 555 1st St San Fernando, California, 91340	FROM:	Taft Electric Company 1694 Eastman Avenue Ventura California, 93003
PCO NUMBER/REVISION:	009 / 0	CONTRACT:	1 - Marshall ES Prime Contract
REQUEST RECEIVED FROM:		CREATED BY:	Matt Gobuty (Taft Electric Company)
STATUS:	Pending - In Review	CREATED DATE:	12/7 /2018
REFERENCE:		FIELD CHANGE:	No
SCHEDULE IMPACT:		LOCATION:	
		TOTAL AMOUNT:	\$6,430.00

POTENTIAL CHANGE ORDER TITLE: Closet Power Outlets

CHANGE REASON: RFI Directive

POTENTIAL CHANGE ORDER DESCRIPTION: *(The Contract Is Changed As Follows)*

We are submitting the above cost for the additional work required as directed in RFI 318:
Add Power Outlets to classroom closets \$6,430

~~If data outlets are also needed:~~
~~Add Power & Data Outlets: \$10,919~~ only power per District IT

This change proposal is based on the usual cost elements such as labor, materials and markup and does not include any amount for impacts such as interference, trade stacking, disruptions, rescheduling, changes in the sequence of work, delays and or associated acceleration. We expressly reserve our right to submit our request for any of these items should we be faced with performing work under any of these conditions.

This cost proposal supersedes all previously submitted cost proposals relating to this same work. The work of other trades which may be required to complete this change order is not part of this proposal

This quote is valid for 30 calendar days from the above date. We reserve our right to re-quote this proposal should the approval take longer than 30 days.

Attached is the back up for your review. Please call should you have any questions.

Exclusions

- Any shift work, holiday work, or overtime labor, all work is to be performed during normal working hrs Monday-Friday between 7AM & 3:30PM
- Any and all parts and labor not specifically listed above.
- Any permits or fees.
- Any costs associated with the design, engineering (including wet stamps), or approval process.
- Any access panels.

ATTACHMENTS:

J ID: 2258
 Project: Marshall ES COR

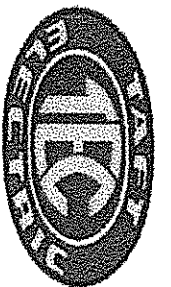

Takeoff

Order: TAFT
 Labor Level: TAFT

7 Dec 2018 10:10:04

Foreign Closet Outlets

Item #	Qty	U/M	Q/M	Size	Description	Material Unit	Material Result	Labor Unit	Labor Result
	0.00				ADD 12 PWR OUTLETS				
					DX 2G	0.000	0.00	0.0000	0.00
					DX RECEPT SPECIFICATION GRADE	4.8500	116.40	0.1800	4.12
140016	24.00	EA	M	20A		3.3048	39.66	0.0600	0.72
140541	12.00	EA	M	2-DUPLEX	2G STAINLESS STEEL PLATE	4.6794	56.15	0.1200	1.44
150041	12.00	EA	M	2-1/8"Ø 30.3-CI	4"SQ CAB-KO NO BRKT	3.9238	47.09	0.0300	0.36
160722	12.00	EA	M	16"	WALL BOX HANGER + BRACKET	2.7227	32.67	0.0500	0.60
150070	12.00	EA	M	3/4"TRISE 10.0-CI	2G 4"SQ PLASTER-RING	0.0185	1.33	0.0000	0.00
160573	72.00	EA	M	#10 x 1"	TRK SCREW	0.7500	9.00	0.0200	0.24
100090	12.00	EA	M	#14	PIGTAIL W/GRD SCREW	7.3900	88.68	0.1250	1.50
					FIREBLOK GASKET	5.7999	69.60	0.2000	2.40
					CONDUIT SUPPORT	0.0000	0.00	0.0000	0.00
					3/4" FLEX (3)#12+G	0.8480	508.80	0.0350	21.00
					FLEXIBLE STEEL CONDUIT	0.1096	131.56	0.0040	4.80
79079	1,200.00	FT	M	12	THHN/THWN CU (SOL)	0.1147	68.84	0.0040	2.40
79111	600.00	FT	M	12	GREEN THHN CU (GRD 20A)	4.1772	50.13	0.1176	1.41
50024	12.00	EA	M	3/4	FLEX COND ANGLE CONN	1.4317	17.18	0.0980	1.18
50035	12.00	EA	M	3/4	FLEX COND STRAIGHT CONN	4.6567	55.88	0.2300	2.76
40208	12.00	EA	M	3/4	GRD BUSHING INSULATED				
Phase Totals:						1,292.97	1,292.97	45.13	45.13
Job Totals:						1,292.97	1,292.97	45.13	45.13

BULLETIN #010

To: Jennifer MacIsaac
CFW

Project Name: Marshall Elementary School
New Classroom Building

Cc: Carl Magnus, Bernards
Michael Rosenberg, IOR

Project Number: 1534.01

From: Jose Arche
CSDA Design Group

Subject: Power for Rack

Date: Nov. 27, 2018

DSA A#: 03-116806

Description:

Provide power outlets at each classroom closet for computer cart docking, typical for the first and second floor.

REFERENCE to RFI 310 issued with drawings.

Revised Drawings:

E-202

E-302

ACTION REQUIRED:

- This is a no cost or time change to the scope of work.
- Provide itemized breakdown of costs/credits for approval by the District.
- Proceed with the work as directed above.
- Proceed as directed below.
- No Action required.

PREPARED BY: Jose R. Arche



REQUEST FOR INFORMATION
FOR SUBCONTRACTOR ACTION

RFI No. : 318

Project: Marshall Elementary - New 6-8 Classroom Bldg.

Date: 11-06-18

Discipline: Electrical

Subject: Power outlets in the closets

DRAWING & SPECIFICATION REFERENCES

Drawing Sheet / Specification	Detail / Sub Section	Comments
E-202		
E-203		

QUESTION

Per job walk regarding the AV systems, District requested that there be data and power outlets added to the closets for charging of the Teachers units. Please provide the required details and location for these added outlets in the closets.

ANSWER

Please see the attached/revise electrical sheets showing the additional information.

Provide new power outlets as shown on sheet E-202 and E-302

RESPONSE DISTRIBUTION

Company	Contact	Date Sent
---------	---------	-----------

Please review and advise Bernards, WITHIN 7 days, if there are any additional costs or schedule impacts associated with incorporating the RFI response with the Contract Work. (Include a brief description and rough order estimate of the change with this notification. If no response is received within 7 days, Bernards shall trust that there is no impact to your Contract Price or Schedule.

Question Initiated By: Sahithya Mavillapalli - Bernards

Submitted By: Sahithya Mavillapalli - Bernards



REQUEST FOR INFORMATION

RFI No.: 318

To: Jose Arche

Date: 11-06-18

Company: CSDA Design Group

Discipline: Electrical

Project: Marshall Elementary - New 6-8 Classroom Bldg.

Subject: Power outlets in the closets

Response Requested By: 11-13-2018

DRAWINGS & SPECIFICATION REFERENCES

Drawing Sheet / Specification	Detail / Sub Section	Comments
E-202		
E-203	POWER SHEETS E-202 & E-302	

QUESTION

Per job walk regarding the AV systems, District requested that there be data and power outlets added to the closets for charging of the Teachers units. Please provide the required details and location for these added outlets in the closets.

ANSWER

Please see the attached/revised electrical sheets showing the additional information.

J.Kraut - TREI

PROVIDE new power outlets as shown on sheet E-202 & E-302
CSDA, ja.

Response Provided By:

Name

jose arche CSDA

Company

11-28-18

Date

Question Initiated By: Sahithya Mavillapalli - Bernards

Submitted By: Sahithya Mavillapalli - Bernards

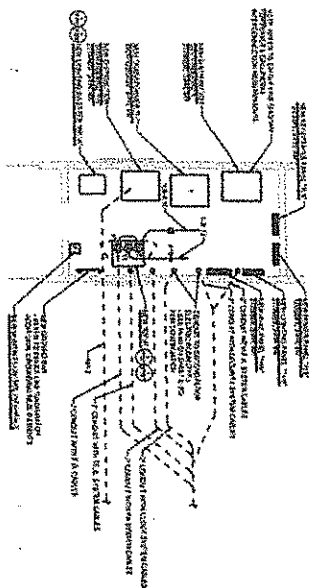

2 FIRST FLOOR - ENLARGED ELECTRIC ROOM

- ELECTRICAL NOTES**
1. VERIFY EXISTING OF ALL ELECTRICAL WORK.
 2. VERIFY EXISTING OF ALL ELECTRICAL WORK.
 3. VERIFY EXISTING OF ALL ELECTRICAL WORK.
 4. VERIFY EXISTING OF ALL ELECTRICAL WORK.
 5. VERIFY EXISTING OF ALL ELECTRICAL WORK.
 6. VERIFY EXISTING OF ALL ELECTRICAL WORK.
 7. VERIFY EXISTING OF ALL ELECTRICAL WORK.
 8. VERIFY EXISTING OF ALL ELECTRICAL WORK.
 9. VERIFY EXISTING OF ALL ELECTRICAL WORK.
 10. VERIFY EXISTING OF ALL ELECTRICAL WORK.

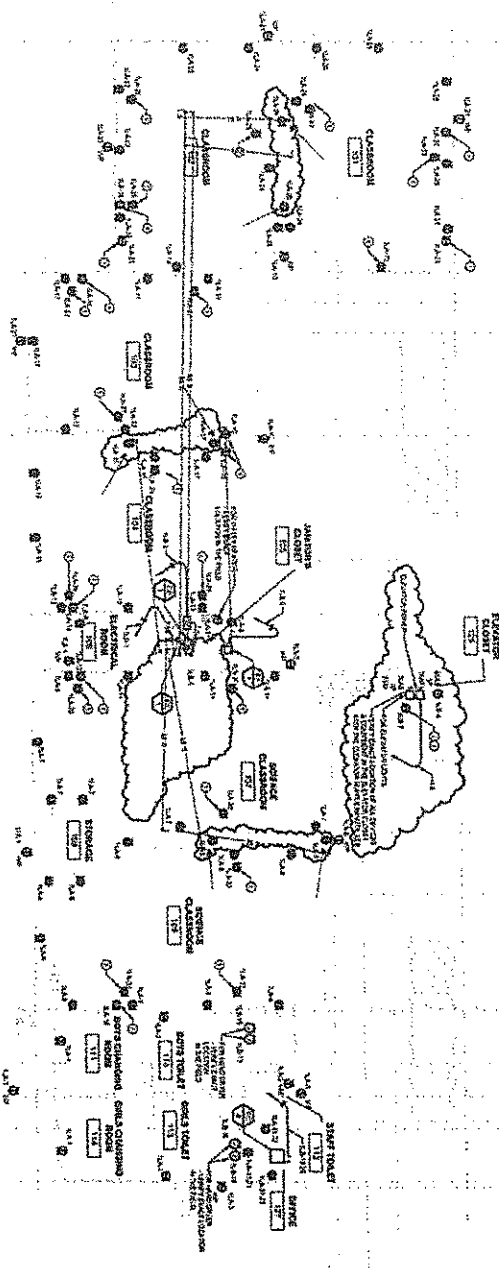

1 FIRST FLOOR PLAN - POWER

REFERENCE TO RFI 316,
POWER @ CLASSROOMS
STORAGE - 11-28-18

DATE: 11/28/18
DRAWN BY: [Name]
CHECKED BY: [Name]



OXHARD SCHOOL DISTRICT
2001 THURSDAY DRIVE
DOWNEY, CA 90241



OXHARD SCHOOL DISTRICT
2001 THURSDAY DRIVE
DOWNEY, CA 90241

OXHARD SCHOOL DISTRICT
2001 THURSDAY DRIVE
DOWNEY, CA 90241

OXHARD SCHOOL DISTRICT
2001 THURSDAY DRIVE
DOWNEY, CA 90241



NOT BE LOANED TO THE PUBLIC
15000 15000
15000 15000
15000 15000



OXFORD SCHOOL DISTRICT
1015 S. 5th
OXFORD, CA 95721
916.831.2111
www.oxford.k12.ca.us

RASHALL NEW CLASSROOM BUILDING
1000 Brookfield Blvd
Oxford, CA 95721
916.831.2111

SECOND FLOOR
PLAN - POWER

E-302

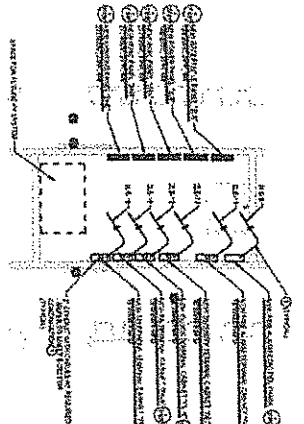

- ELECTRICAL NOTES**
1. ALL WIRING TO BE IN ACCORDANCE WITH THE NATIONAL ELECTRICAL CODE (NEC) AND ALL APPLICABLE LOCAL ORDINANCES.
 2. ALL WIRING TO BE IN ACCORDANCE WITH THE NATIONAL ELECTRICAL CODE (NEC) AND ALL APPLICABLE LOCAL ORDINANCES.
 3. ALL WIRING TO BE IN ACCORDANCE WITH THE NATIONAL ELECTRICAL CODE (NEC) AND ALL APPLICABLE LOCAL ORDINANCES.
 4. ALL WIRING TO BE IN ACCORDANCE WITH THE NATIONAL ELECTRICAL CODE (NEC) AND ALL APPLICABLE LOCAL ORDINANCES.
 5. ALL WIRING TO BE IN ACCORDANCE WITH THE NATIONAL ELECTRICAL CODE (NEC) AND ALL APPLICABLE LOCAL ORDINANCES.
 6. ALL WIRING TO BE IN ACCORDANCE WITH THE NATIONAL ELECTRICAL CODE (NEC) AND ALL APPLICABLE LOCAL ORDINANCES.
 7. ALL WIRING TO BE IN ACCORDANCE WITH THE NATIONAL ELECTRICAL CODE (NEC) AND ALL APPLICABLE LOCAL ORDINANCES.
 8. ALL WIRING TO BE IN ACCORDANCE WITH THE NATIONAL ELECTRICAL CODE (NEC) AND ALL APPLICABLE LOCAL ORDINANCES.
 9. ALL WIRING TO BE IN ACCORDANCE WITH THE NATIONAL ELECTRICAL CODE (NEC) AND ALL APPLICABLE LOCAL ORDINANCES.
 10. ALL WIRING TO BE IN ACCORDANCE WITH THE NATIONAL ELECTRICAL CODE (NEC) AND ALL APPLICABLE LOCAL ORDINANCES.

2 SECOND FLOOR - ENLARGED ELECTRIC ROOM

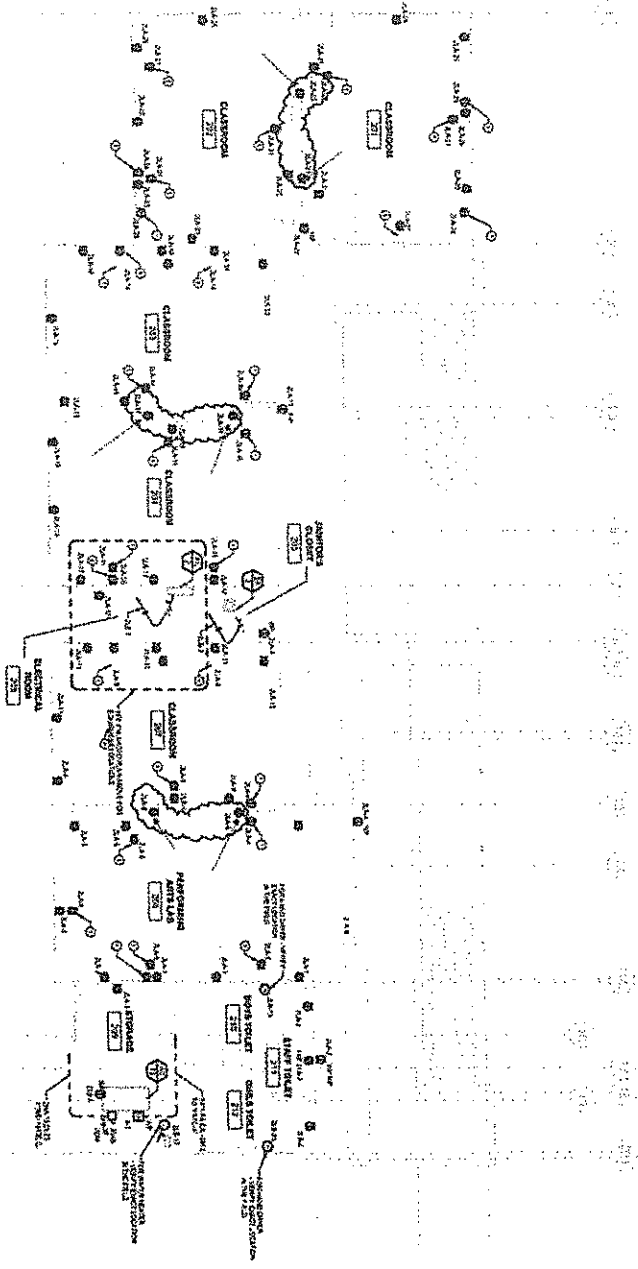

1 SECOND FLOOR PLAN - POWER

REFERENCE TO RPI 318
POWER @ CLASSROOMS
STORAGE - 11-26-18

**TAFT ELECTRIC CO.
LABOR BURDEN REPORT**
Period of July 30, 2018 to December 30, 2018

	JOURNEYMAN				FOREMAN				GEN. FOREMAN			
	St. Time	1.5 Time	2 Time		St. Time	1.5 Time	2 Time		St. Time	1.5 Time	2 Time	
VENTURA COUNTY LOCAL 952												
WAGES	\$ 39.08	\$ 58.62	\$ 78.16		\$ 43.50	\$ 65.24	\$ 86.99		\$ 47.91	\$ 71.87	\$ 95.82	
HEALTH & WELFARE	\$ 8.18	\$ 8.18	\$ 8.18		\$ 8.18	\$ 8.18	\$ 8.18		\$ 8.18	\$ 8.18	\$ 8.18	
LOCAL PENSION	16.64	24.96	33.28		16.64	24.96	33.28		16.64	24.96	33.28	
TRAINING FUND	1.00	1.00	1.00		1.00	1.00	1.00		1.00	1.00	1.00	
LMCC	0.50	0.50	0.50		0.50	0.50	0.50		0.50	0.50	0.50	
N.E.I.F. (1%)	0.39	0.59	0.78		0.43	0.65	0.87		0.48	0.72	0.96	
NAT. PENSION (3%)	1.17	1.76	2.34		1.30	1.96	2.61		1.44	2.16	2.87	
UNION BURDEN	\$ 27.88	\$ 36.98	\$ 46.09		\$ 28.06	\$ 37.25	\$ 46.44		\$ 28.24	\$ 37.51	\$ 46.79	
F.I.C.A. (7.65%)	\$ 2.99	\$ 4.48	\$ 5.98		\$ 3.33	\$ 4.99	\$ 6.65		\$ 3.67	\$ 5.50	\$ 7.33	
F.U.I. (0.8%)	0.31	0.47	0.63		0.35	0.52	0.70		0.38	0.57	0.77	
S.U.I. (6.2%)	2.42	3.63	4.85		2.70	4.05	5.39		2.97	4.46	5.94	
TAX BURDEN	\$ 5.73	\$ 8.59	\$ 11.45		\$ 6.37	\$ 9.56	\$ 12.74		\$ 7.02	\$ 10.53	\$ 14.04	
LIABILITY INSURANCE	5.4%											
WORKMAN'S COMP	2.11	3.17	4.22		2.35	3.52	4.70		2.59	3.88	5.17	
INSURANCE BURDEN	1.05	1.05	1.05		1.17	1.17	1.17		1.29	1.29	1.29	
DIRECT COST PER HOUR	\$ 3.16	\$ 4.22	\$ 5.27		\$ 3.52	\$ 4.69	\$ 5.87		\$ 3.88	\$ 5.17	\$ 6.46	
DIRECT COST PER DAY	\$ 75.85	\$108.41	\$140.97		\$ 81.45	\$116.75	\$152.05		\$ 87.05	\$125.08	\$163.12	
DIRECT COST PER WEEK	\$ 606.81		\$ 65.12		\$ 651.59		\$ 70.60		\$ 696.36		\$ 76.07	
	\$ 3,034.05				\$ 3,257.93				\$ 3,481.81			

NOTES:
WORKMAN'S COMP RATES: LESS THAN \$32.00/HOUR = 5.658%
WORKMAN'S COMP RATES: GREATER THAN \$32.00/HOUR = 2.693%

TAFT ELECTRIC CO.
Labor Rate
Jan 1 thru July 30 2018

**VENTURA COUNTY
 LOCAL 952**

	JOURNYPMAN			FOREMAN			GEN. FOREMAN			
	St. Time	1.5 Time	2 Time	St. Time	1.5 Time	2 Time	St. Time	1.5 Time	2 Time	
Direct Cost p/ hour	\$75.85	\$108.41	\$140.97	\$81.45	\$116.75	\$152.05	\$87.05	\$125.08	\$163.12	
Small Tools	0%	\$0.00	\$0.00	\$0.00	\$0.00	\$0.00	\$0.00	\$0.00	\$0.00	
Safety	2.5%	\$1.90	\$1.90	\$1.90	\$1.90	\$1.90	\$1.90	\$1.90	\$1.90	
Clean Up	3.0%	\$2.28	\$2.28	\$2.28	\$2.28	\$2.28	\$2.28	\$2.28	\$2.28	
Totals		\$80.02	\$112.58	\$145.14	\$85.62	\$120.92	\$156.22	\$91.22	\$129.25	\$167.29
Mark Up	0.0%	\$0.00	\$0.00	\$0.00	\$0.00	\$0.00	\$0.00	\$0.00	\$0.00	
Total		\$80.02	\$112.58	\$145.14	\$85.62	\$120.92	\$156.22	\$91.22	\$129.25	\$167.29

VENTURA COUNTY
 LOCAL 952
 APPRENTICES

TAFT ELECTRIC COMPANY
 Labor Rate
 Jan 1 thru July 30 2018

	JRYM	40%	45%	50%	60%	70%	85%				
Direct Cost	\$75.85	\$29.46	\$31.99	\$51.66	\$56.73	\$61.80	\$68.42	\$0.00	\$0.00	\$0.00	\$0.00
Small Tools (3%)	0%	\$0.00	\$0.00	\$0.00	\$0.00	\$0.00	\$0.00	\$0.00	\$0.00	\$0.00	\$0.00
Safety (2.5%)	2.5%	\$1.90	\$1.90	\$1.90	\$1.90	\$1.90	\$1.90	\$1.90	\$1.90	\$1.90	\$1.90
Clean Up (3%)	3%	\$2.28	\$2.28	\$2.28	\$2.28	\$2.28	\$2.28	\$2.28	\$2.28	\$2.28	\$2.28
Sub Total	\$80.02	\$33.63	\$36.16	\$55.83	\$60.90	\$65.97	\$72.59	\$0.00	\$0.00	\$0.00	\$0.00
Mark Up	0%	\$0.00	\$0.00	\$0.00	\$0.00	\$0.00	\$0.00	\$0.00	\$0.00	\$0.00	\$0.00
Grand Total	\$80.02	\$33.63	\$36.16	\$55.83	\$60.90	\$65.97	\$72.59	\$0.00	\$0.00	\$0.00	\$0.00

TAFT ELECTRIC CHANGE REQUEST PROPOSAL

LABOR RATE CALCULATIONS

PROJECT: Elm School Reconstruction JOB# 2551 TEC CR#: 0
 CUST RFP#: 0

STRAIGHT TIME CALCULATIONS

CLASS	HOURS	RATE
G. FOREMAN	0.00	\$0.00
FOREMAN	1.00	\$85.62
JOURNEYMAN	2.00	\$80.02
APPRENTICE	1.00	\$72.59
	0.00	\$0.00
	0.00	\$0.00
	0.00	\$0.00
	0.00	\$0.00
	0.00	\$0.00
	0.00	\$0.00
COMPOSITE RATE		\$79.56

SHIFT WORK CALCULATIONS

CLASS	HOURS	RATE
G. FOREMAN	0.00	\$74.93
FOREMAN	0.00	\$69.80
JOURNEYMAN	0.00	\$64.65
APPRENTICE	0.00	\$53.56
	0.00	\$0.00
	0.00	\$0.00
	0.00	\$0.00
	0.00	\$0.00
	0.00	\$0.00
	0.00	\$0.00
COMPOSITE RATE		\$0.00

OVERTIME CALCULATIONS

CLASS	HOURS	RATE
G. FOREMAN	0.00	\$87.83
FOREMAN	0.00	\$92.70
JOURNEYMAN	0.00	\$85.40
APPRENTICE	0.00	\$74.65
	0.00	\$0.00
	0.00	\$0.00
	0.00	\$0.00
	0.00	\$0.00
	0.00	\$0.00
	0.00	\$0.00
COMPOSITE RATE		\$0.00

GRAVEYARD CALCULATIONS

CLASS	HOURS	RATE
G. FOREMAN	0.00	\$87.83
FOREMAN	0.00	\$92.70
JOURNEYMAN	0.00	\$85.40
APPRENTICE	0.00	\$74.65
	0.00	\$0.00
	0.00	\$0.00
	0.00	\$0.00
	0.00	\$0.00
	0.00	\$0.00
	0.00	\$0.00
COMPOSITE RATE		\$0.00

DOUBLE TIME CALCULATIONS

CLASS	HOURS	RATE
G. FOREMAN	0.00	\$109.30
FOREMAN	0.00	\$115.60
JOURNEYMAN	0.00	\$106.15
APPRENTICE	0.00	\$89.95
	0.00	\$0.00
	0.00	\$0.00
	0.00	\$0.00
	0.00	\$0.00
	0.00	\$0.00
	0.00	\$0.00
COMPOSITE RATE		\$0.00

OTHER CALCULATIONS

CLASS	HOURS	RATE
G. FOREMAN	0.00	\$109.30
FOREMAN	0.00	\$115.60
JOURNEYMAN	0.00	\$106.15
APPRENTICE	0.00	\$89.95
	0.00	\$0.00
	0.00	\$0.00
	0.00	\$0.00
	0.00	\$0.00
	0.00	\$0.00
	0.00	\$0.00
COMPOSITE RATE		\$0.00

TART ELECTRIC COMPANY
LABOR BURDEN REPORT
Period of July 30, 2018 to December 30, 2018

VENTURA COUNTY LOCAL 952
APPRENTICES - Indentured after 10/01/2012

	40%	45%	50%	55%	60%	65%	70%	75%	80%	85%			
WAGES	\$ 15.63	\$ 23.45	\$ 17.59	\$ 26.38	\$ 18.54	\$ 29.31	\$ 23.45	\$ 35.17	\$ 27.36	\$ 41.83	\$ 33.22	\$ 48.83	
HEALTH & WELFARE	\$ 8.18	\$ 8.18	\$ 8.18	\$ 8.18	\$ 8.18	\$ 8.18	\$ 8.18	\$ 8.18	\$ 8.18	\$ 8.18	\$ 8.18	\$ 8.18	
LOCAL PENSION	-	-	-	-	18.84	24.96	18.84	24.96	18.84	24.96	18.84	24.96	
TRAINING FUND	1.00	1.00	1.00	1.00	1.00	1.00	1.00	1.00	1.00	1.00	1.00	1.00	
LMCC	0.47	0.70	0.53	0.79	0.59	0.88	0.50	0.82	0.50	0.82	0.50	0.82	
NAT. PENSION (3%)	0.16	0.23	0.18	0.26	0.20	0.29	0.23	0.35	0.27	0.41	0.33	0.50	
N.E.I.F. (1%)	-	-	-	-	-	-	-	-	-	-	-	-	
UNION BURDEN	\$ 9.81	\$ 10.12	\$ 9.88	\$ 10.24	\$ 27.10	\$ 35.81	\$ 27.26	\$ 36.85	\$ 27.41	\$ 36.26	\$ 27.65	\$ 36.63	
F.I.C.A. (7.65%)	\$ 1.20	\$ 1.79	\$ 1.35	\$ 2.02	\$ 1.49	\$ 2.24	\$ 1.79	\$ 2.69	\$ 2.09	\$ 3.14	\$ 2.54	\$ 3.81	
F.U.I. (.8%)	0.13	0.19	0.14	0.21	0.16	0.23	0.19	0.28	0.22	0.33	0.27	0.40	
S.U.I. (6.2%)	0.97	1.45	1.09	1.64	1.21	1.82	1.45	2.18	1.70	2.54	2.08	3.09	
TAX BURDEN	\$ 2.29	\$ 3.44	\$ 2.58	\$ 3.86	\$ 2.86	\$ 4.29	\$ 3.44	\$ 5.15	\$ 4.01	\$ 6.01	\$ 4.87	\$ 7.30	
LIABILITY INSURANC	5.4%	\$ 0.84	\$ 1.27	\$ 0.95	\$ 1.42	\$ 1.06	\$ 1.58	\$ 1.27	\$ 1.90	\$ 1.48	\$ 2.22	\$ 1.79	\$ 2.69
WORKMAN'S COMP	0.88	0.88	1.09	1.00	1.11	1.11	1.33	1.33	1.55	1.55	0.89	0.89	
INSURANCE BURDEN	\$ 1.73	\$ 2.15	\$ 1.94	\$ 2.42	\$ 2.16	\$ 2.69	\$ 2.59	\$ 3.23	\$ 3.03	\$ 3.76	\$ 2.69	\$ 3.59	
DIRECT COST PER HOUR	\$ 29.46	\$ 39.15	\$ 31.99	\$ 42.90	\$ 51.56	\$ 72.10	\$ 56.73	\$ 79.80	\$ 61.80	\$ 87.09	\$ 88.42	\$ 97.34	
DIRECT COST PER DAY	\$ 238.65	\$ 313.21	\$ 255.92	\$ 343.19	\$ 413.32	\$ 576.84	\$ 453.87	\$ 638.42	\$ 494.42	\$ 697.37	\$ 547.37	\$ 756.86	
DIRECT COST PER WEEK	\$ 1,178.24	\$ 1,568.07	\$ 1,279.62	\$ 1,715.03	\$ 2,066.50	\$ 2,884.19	\$ 2,269.36	\$ 3,192.12	\$ 2,472.12	\$ 3,472.12	\$ 2,736.86	\$ 3,736.86	

NOTES:
WORKMAN'S COMP RATES: LESS THAN \$32.00/HOUR = 5.8589%
WORKMAN'S COMP RATES: GREATER THAN \$32.00/HOUR = 2.693%

#17-117

CONSTRUCTION SERVICES AGREEMENT

This Construction Services Agreement (hereinafter referred to as the "Agreement") is entered into this 24th day of August 2017, by and between the Oxnard School District, a California school district organized and existing under the laws of the State of California (hereinafter referred to as the "District") and Bernards which is a contractor licensed by the State of California, with its principal place of business at 555 First Street, San Fernando, CA 91340 (hereinafter referred to as "Contractor").

WHEREAS, the District operates Marshall Elementary School, located at 2900 Thurgood Marshall Drive, Oxnard, California 93036 (hereinafter referred to as the "School Facility"); and

WHEREAS, the District desires to construct and modernize facilities and improvements (as more fully described below) at those portions of the School Facility identified in the Site Lease, as defined in Section 1G below (the "Site"); and

WHEREAS, the District has determined that it is in its best interests to pursue the improvements to the School Facility through the lease-leaseback method of project delivery pursuant to California Education Code §17406 which permits the governing board of the District, without advertising for bids, to lease to Contractor property owned by the District if the instrument by which property is leased requires the lessee to construct, or provide for the construction, on the leased property, of a facility for the use of the District during the term of the lease, and provides that title to that facility shall vest in the District at the expiration of the lease; and

WHEREAS, the District desires to finance a portion of the improvements utilizing the lease/leaseback methodology; and

WHEREAS, the District has conducted an RFQ process by which it selected Contractor; and

WHEREAS, the District intends to undertake work to improve the School Facility, the scope of which is generally described in **Exhibit A** attached hereto and incorporated by reference herein; and

WHEREAS, in connection with the approval of this Agreement, the District will enter into a site lease with Contractor, under which it will lease to Contractor the Site in order for Contractor to construct the Project as described in the Scope of Work set forth generally in **Exhibit A** (hereinafter referred to as the "Scope of Work"); and

WHEREAS, assuming that the District and Contractor can agree on the terms, including the price, for the additional scope of work, the District and Contractor anticipate that the scope of the Project may be amended to include additional work; and

- 1 -

OXNARD SCHOOL DISTRICT

CONSTRUCTION SERVICES AGREEMENT

Marshall New Classroom Building Project

August 24th, 2017

#17-117

WHEREAS, Contractor will lease the Site back to the District pursuant to a sublease agreement, under which the District will be required to make payments to Contractor for the use and occupancy of the Site, including the Project (hereinafter the "Financing"); and

WHEREAS, Contractor represents that it is sufficiently experienced in the construction of the type of facility and type of work sought by the District and is willing to perform said work for lease and the Financing to the District, all as more fully set forth herein; and

WHEREAS, at the expiration of the Site Lease, title to the Site and the improvements thereon will vest with the District;

NOW, THEREFORE, in consideration of the covenants hereinafter contained, the District and Contractor agree as follows:

SECTION 1. DEFINITIONS

- A. **Construction.** The term "Construction" as used in this Agreement includes all labor and services necessary for the construction of the Project, and all materials, equipment, tools, supplies and incidentals incorporated or to be incorporated in such construction as fully described in the Scope of Work set forth in **Exhibit A** attached hereto. Unless otherwise expressly stipulated, Contractor shall perform all work and provide and pay for all materials, labor tools and equipment, including, but not limited to, light, water, and power, necessary for the proper execution and completion of the Project shown on the drawings and described in the specifications developed pursuant to this Agreement.
- B. **Construction Documents.** The term "Construction Documents" means the final drawings, profiles, cross sections, design development drawings, construction drawings, and supplemental drawings based on the plans and specifications developed for the Project pursuant to the Scope of Work set forth in **Exhibit A** attached hereto, including any reference specifications or reproductions prepared by the architect hired by the District (the "Architect") and specifications approved by the District, the Division of the State Architect ("DSA"), and the local agencies having jurisdiction or other regulatory agencies whose approval may be required, which show or describe the location, character, dimensions or details for the Project and specifications for construction thereof.
- C. **Contract Documents.** The term "Contract Documents" as used in this Agreement refers to those documents which form the entire agreement by and between the District and Contractor. The Contract Documents consist of this Agreement, including the exhibits and attachments hereto, the Site Lease, including the exhibits and

#17-117

attachments thereto, the Sublease, including the exhibits and attachments thereto, the Project Manual including the General Conditions thereto, as amended, which is incorporated herein (the "General Conditions"), and the Construction Documents. The term "Contract Documents" shall include all modifications and addenda thereto.

- D. **Guaranteed Maximum Price.** The term "Guaranteed Maximum Price" or "GMP" as used in this Agreement means the Guaranteed Maximum Price established pursuant to Section 5 of this Agreement to be used to calculate the Tenant Improvement Payments and the Sublease Payments to be paid by the District to Contractor pursuant to the Sublease, subject only to any adjustments for Extra Work/Modifications as provided in Section 10 of this Agreement.
- E. **Not Used for this Agreement**
- F. **Project.** The term "Project" shall mean the improvements and facilities to be constructed and installed by Contractor at the School Facility which will result in complete and fully operational facilities as more fully set forth on **Exhibit A** attached hereto.
- G. **Project Manual.** The term "Project Manual" shall mean the compilation of the Specification sections including Division 0, Procurement and Contracting Requirements, Division 1 General Requirements, and technical specifications Division 2 through 33 prepared by the Architect and approved by the District, the DSA, or other regulatory agencies which show or describe the location, character, dimensions or details for the Project, which shall be delivered to Contractor upon execution of this Agreement.
- H. **Site.** The term "Site" as used in this Agreement shall mean those certain parcels of real property and improvements thereon (if any) more particularly described in **Exhibit A** to the Site Lease.
- I. **Site Lease.** The term "Site Lease" as used in this Agreement shall mean the certain Site Lease dated of even date herein between the District and Contractor, together with any duly authorized and executed amendment(s) thereto, pursuant to which the District leases the Site to Contractor.
- J. **Specifications.** The term "Specifications" shall mean those numbered specifications set forth in the Project Manual which shall accompany this Agreement and which are incorporated by reference herein. Individual Specifications may be referred to by their specification number as set forth in the Project Manual.

#17-117

- K. **Subcontractor.** As used in this Agreement, the term "Subcontractor" means any person or entity, including trade contractors, who have a contract with Contractor to perform any of the Construction.
- L. **Sublease.** The term "Sublease" as used in this Agreement shall mean the certain Sublease dated of even date herein between the District and Contractor, together with any duly authorized and executed amendment(s) thereto, pursuant to which the District subleases the Site from Contractor.
- M. **Sublease Payments.** The term "Sublease Payments" as used in this Agreement shall mean the payments made by the District to Contractor pursuant to Section 6 of the Sublease.
- N. **Tenant Improvement Payments.** The term "Tenant Improvement Payments" as used in this Agreement shall mean the payments made by the District to Contractor pursuant to Section 6 of the Sublease.

SECTION 2. CONTRACTOR'S DUTIES AND STATUS

Contractor covenants with the District to furnish reasonable skill and judgment in constructing the Project. Contractor agrees to furnish efficient business administration and superintendence and to furnish at all times an adequate supply of professionals, workers, and materials and to perform the work appropriately, expeditiously, economically, and consistent with the Contract Documents.

SECTION 3. ADDITIONAL SERVICES

If the District requests Contractor to perform additional services not described in this Agreement, Contractor shall provide a cost estimate and a written description of the additional work necessary to complete such additional services. The cost for such additional services shall be negotiated and agreed upon in writing in advance of Contractor performing or contracting for such additional services, and such cost shall be used to adjust the GMP established pursuant to Section 5 hereof. In the absence of a written agreement, the District will not compensate Contractor for additional services, will not adjust the GMP for such additional services, and Contractor will not be required to perform them. It is understood and agreed that if Contractor performs any services that it claims are additional services without receiving prior written approval from the District Board of Education, Contractor shall not be paid for such claimed additional services and the GMP will not be adjusted. Nothing in this Agreement shall be construed as limiting the valuation of such additional services and amount that the GMP will be adjusted for such additional services, should a written agreement for such services be executed by the parties. Notwithstanding the foregoing, Contractor shall not be entitled to compensation, nor will the GMP be adjusted, for additional services required as a result of Contractor's acts, errors or omissions.

SECTION 4. OWNERSHIP OF PLANS AND DOCUMENTS

All original field notes, written reports, drawings, specifications, Construction Documents, and other documents, produced or developed for the Project are the property of the District, regardless of whether the Project is constructed, and shall be furnished to the District. Such documents are not to be used by Contractor or by the Subcontractors on other work nor shall Contractor nor the Subcontractors claim any right to such documents. This shall not deprive Contractor from retaining electronic data or other reproducible copies of the Construction Documents or the right to reuse information contained in them in the normal course of Contractor's professional activities.

SECTION 5. ESTABLISHMENT OF GUARANTEED MAXIMUM PRICE

The "GMP" for the Project shall be **Eight Million Nine Hundred Ninety-Four Thousand Two Hundred Thirty-Six and No/Hundredths Dollars (\$8,994,236.00)**. The GMP consists of (1) no Preconstruction Fee, a Sublease Tenant Improvement Payment in the amount of **Eight Million One Hundred Ninety-Eight Thousand Five Hundred Ninety-Two Dollars and No Cents (\$8,198,592.00)** and, (2) a Contractor Contingency in the amount of **Three Hundred Forty-Five Thousand Nine Hundred Thirty-Two Dollars and No Cents (\$345,932.00)**, and, (3) Sublease Payments in the amount of **\$74,952.00** per month for **6** months, for a total lease value of **Four Hundred Forty-Nine Thousand Seven Hundred Twelve Dollars and No Cents (\$449,712.00)** pursuant to terms and payment schedule as set forth in the Sublease. THE "GMP" WILL NOT BE ESTABLISHED UNTIL DSA HAS APPROVED THE FINAL PLANS AND SPECIFICATIONS AND THE BOARD APPROVES IT PRIOR TO NTP FOR CONSTRUCTION. The GMP will then be brought to the Board of Trustees as a revision to this section of this agreement. Until such time this section will remain incomplete, the Site Lease and Sublease will not begin and the Contractor will proceed with subcontractor bidding to establish the final GMP for Board acceptance.

The GMP is based upon the DSA approved plans and specifications to exist after this Agreement is entered into between Contractor and the District, and more fully described and referenced in the Scope of Work to be set forth in **Exhibits A and B** attached hereto. Prior to DSA approval Contractor did not perform Preconstruction Services to assist in designing the project. Upon DSA approval of plans and specifications, and the establishment of the GMP the Contractor shall assume the risk of cost overruns which were foreseeable at the time this Agreement is entered into and the GMP determined, except for undocumented events of the type set forth in Section 19 hereof, work mandated by an outside agency after issuance of Construction Documents that could not have been reasonably foreseen from review of the Contract Documents, or costs arising from undocumented geotechnical issues. Contractor acknowledges that (i) Contractor has conducted a site inspection and is familiar with the site conditions based on records, studies and visible conditions relating to construction and labor and (ii) Contractor has reviewed the Contract Documents and is familiar with the contents thereof. District directed changes to the scope of the Project not contemplated in the Scope of Work shall

#17-117

be deemed Extra Work/Modifications pursuant to the procedures set forth in Section 10 of this Agreement. The GMP shall include, but not be limited to, increases in labor and materials. The GMP has been used to calculate the Tenant Improvement Payments and the Sublease Payments to be paid by the District to Contractor pursuant to the Sublease. The GMP includes the cost of all labor, materials, equipment, general conditions, overhead, profit and a Contractor Contingency as indicated above.

The Contractor Contingency is for the purpose of covering the cost of very specific issues that may arise during construction and it may be used only upon the written agreement of the Contractor, the architect of record, and the District. The Contractor Contingency is to be used only to pay Contractor for the following enumerated reasons: (1) additional costs resulting from discrepancies in the bid buy-out process; (2) conflicts, discrepancies or errors in the Construction Documents; (3) work required by the Inspector of Record or any governmental agency involved in the permitting or approval/certification process that is not otherwise shown in the Construction Documents; and (4) any other items of cost agreed to in writing by the Contractor and District to be included in the Contractor Contingency. The Contractor Contingency shall not be used for costs incurred as a result of Contractor's acts, errors or omissions.

Contractor shall be responsible for tracking expenditures of the Contractor Contingency and shall provide periodic written updates to the District as directed. Unused Contractor Contingency and Allowances at Project completion will reduce the GMP and will result in an adjustment of the Tenant Improvement Payments and possibly the Sublease Payments.

The District shall at all times have the right to reduce the scope of the Project. If the District reduces the scope of the Project, the GMP shall be reduced commensurate with the reduced Scope of Work pursuant to the provisions of Section 10, below, and will result in an adjustment of the Tenant Improvement Payments and, if applicable, the Sublease Payments.

SECTION 6. NOTICE TO PROCEED WITH CONSTRUCTION

Upon receipt of an approved GMP, the District shall issue a notice to Contractor to proceed with the Construction of the Project. In the event that a Notice to Proceed with Construction is not issued for the Project, the Site Lease and the Sublease shall terminate upon written notice from the District to Contractor that a Notice of Proceed will not be issued.

SECTION 7. SAVINGS

If Contractor realizes a savings on one aspect of the Project, such savings shall be tracked and Contractor shall provide periodic written updates of such savings. Such savings shall be added to the Contractor Contingency and the use of such savings shall be as set forth in Section 5. However, if such savings are not so utilized, the amount of such savings shall reduce the GMP and will result in an adjustment of the Tenant Improvement Payments and, if applicable, the Sublease Payments.

- 6 -

SECTION 8. SELECTION OF SUBCONTRACTORS

In the interest of minimizing the expenditure of funds for the construction of the Project, Contractor agrees to select Subcontractors who are appropriately licensed by the State of California for each trade component of the Project in a manner that fosters competition. Contractor agrees that it will either solicit bids from potential subcontractors pursuant to the competitive bid procedures set forth in the California Public Contract Code, including specifically Public Contract Code section 20110, et seq., or that it will utilize an informal bidding process established by Contractor which also incorporates competitive bid procedures. Regardless of the method Contractor employs, Contractor will make a good faith effort to contact and utilize DVBE contractors and suppliers in securing bids for performance of the Project in accordance with the procedures set forth in Section 1.77 of the General Conditions. In the event that Contractor chooses to select Subcontractors pursuant to an informal bidding process, Contractor shall ensure that it receives at least three competitive quotes from potential subcontractors for each trade component of the Project, unless the parties agree otherwise on a trade-by-trade basis. The District reserves the right to oversee the bidding process. Contractor shall inform all bidders that the District will not be a party to any contracts for construction services executed by Contractor and selected bidders. Contractor shall submit a listing of proposed subcontractors to the District for the District's review. In no case, will Contractor award any sub-contracts until the District has concurred in the scope and price of the sub-contracted services. In addition, Contractor shall provide the District with full documentation regarding the bids or competitive quotes received by Contractor. In no event, shall such documentation be redacted or obliterated. In the event Contractor does not comply with this provision, the District may terminate this Agreement in accordance with the provisions of the General Conditions. Subcontractors awarded contracts by Contractor shall be afforded all the rights and protections of listed subcontractors under the provisions of the Subletting and Subcontracting Fair Practices Act (Public Contract Code Section 4100, et seq.).

SECTION 9. CONSTRUCTION SCOPE OF WORK

- A. Prior to commencing Construction, Contractor shall comply with the initial schedule requirements set forth in the General Conditions.
- B. Contractor shall complete the Construction pursuant to the Construction Documents as amended subject to any additional DSA or other regulatory approvals as may be required, performing all work set forth in the Scope of Work, and shall make reasonable efforts in scheduling to prevent disruption to classes.
- C. Contractor shall be responsible for complying with all applicable building codes, including without limitation mechanical codes, electrical codes, plumbing codes and fire codes, each of the latest edition, required by the regulatory agencies and for arranging and overseeing all necessary inspections and tests including inspections by

#17-117

the DSA or regulatory agencies, permits and occupancy permits, and ensuring compliance with any Federal and State laws, including, but not limited to, safety procedures and requirements, and construction employee training programs which cover among other items, hazardous chemicals and materials.

- D. Contractor shall establish procedures for the protection of all existing structures, equipment, utilities, and other existing improvements, both on-site and off-site. Contractor assumes all risk of loss of vandalism, theft of property or other property damage ("Vandalism") which occurs at a site at which Contractor is undertaking construction of the Project. Contractor assumes all risk of loss which occurs where Contractor is undertaking construction of the Project from causes due to negligence or misconduct by Contractor, its officers, employees, subcontractors, licensees and invitees. Contractor shall replace District property damaged by such Vandalism or theft or compensate the District for such loss, including payment of out of pocket expenses such as insurance deductibles the District might incur under such circumstances.
- E. Contractor shall develop a mutually agreed upon program with the District to abate and minimize noise, dust, and disruption to normal activities at the existing facilities at the School Facility, including procedures to control on-site noise, dust, and pollution during construction.
- F. The District shall cause the appropriate professionals to stamp and sign, as required, the original Construction Documents or parts thereof and coordinate the Project's design with all utilities.
- G. Contractor shall, for the benefit of the Subcontractors, attend pre-construction orientation conferences in conjunction with the Architect to set forth the various reporting procedures and site rules prior to the commencement of actual construction. Contractor shall also attend construction and progress meetings with District representatives and other interested parties, as requested by the District, to discuss such matters as procedures, progress problems and scheduling. Contractor shall prepare and promptly distribute official minutes of such meetings to all parties in attendance, including without limitation the District, the Architect and the District Inspector of Record.
- H. Contractor shall incorporate approved changes as they occur, and develop cash flow reports and forecasts for submittal to the District as requested. Contractor shall provide regular monitoring of the approved estimates for Construction costs, showing actual costs for activities in progress, and estimates for uncompleted tasks. Contractor shall maintain cost accounting records on authorized additional services or work performed under unit costs, additional work performed on the basis of actual costs of labor and materials, and for other work requiring accounting records.

- 8 -

#17-117

- I. Contractor shall record the progress of the Project and shall submit monthly written progress reports to the District and the Architect including information on the entire Project, showing percentages of completion and the number and amounts of proposed Extra Work/Modifications and their effect on the construction costs as of the date of each respective report.
- J. Contractor shall keep a log containing a record of weather, Subcontractors, work on the site, number of workers, work accomplished, problems encountered, and other similar relevant data as the District may require. Contractor shall make the log available to the District, the Architect, and the District's project manager. The District shall be promptly advised on all anticipated delays in the Project.
- K. The District shall bear the cost for the DSA Inspector, soils testing, DSA or other regulatory agency fees, and special testing required in the construction of the Project. If additional review or permits become necessary for reasons not due to Contractor's fault or because of DSA or regulatory agency requirements or regulations implemented after the date the Final GMP is established and not reasonably anticipated at the time the Final GMP is established, Contractor may seek additional compensation for the cost of that review as an additional cost. In the alternative, the District may pay such costs directly.

SECTION 10. EXTRA WORK/MODIFICATIONS

- A. The District may prescribe or approve additional work or a modification of requirements or of methods of performing the Construction which differ from the work or requirements set forth in the Construction Documents ("Extra Work/Modifications"); and for such purposes the District may at any time during the life of this Agreement, by written order, make such changes as it shall find necessary in the design, line, grade, form, location, dimensions, plan, or material of any part of the work or equipment specified in this Agreement or in the Construction Documents, or in the quantity or character of the work or equipment to be furnished. In the event conditions develop which, in the opinion of Contractor, makes strict compliance with the specifications impractical, Contractor shall notify the District of the need for Extra Work/Modifications by placing the matter on the agenda of regularly scheduled construction meetings with the District for discussion as soon as practicable after the need for the Extra Work/Modifications is determined. Additionally, Contractor shall submit to the District for its consideration and approval or disapproval, a written request for Extra Work/Modifications before such work is performed. If the District approves the request in writing, the costs of the Extra Work/Modification shall be added to or deducted from the GMP or the Scope of Work shall be modified to complete the Project within the

#17-117

GMP, as applicable. Any adjustments to the GMP will result in an adjustment of the Tenant Improvement Payment and, if applicable, the Sublease Payments.

- B. Extra Work/Modifications include work related to unforeseen underground conditions if, and only if, such conditions are not visible or identified on plans, reports or other documents available to Contractor. Extra Work/Modifications do not include underground conditions that are identified on plans, reports or other documents available to Contractor but are in a location different than is set forth on such plans, reports or other documents available to Contractor. It should be noted, however, that the District has advised and provided Contractor with information regarding the shallow water table and recent projects experience with encountering water when digging. Contractor has included in its calculation of the GMP an amount to mitigate for encountering water when completing the scope of work contemplated herein. Therefore, Extra Work/Modifications do not include expenses incurred by, and/or work performed by, Contractor in connection with such shallow water table and with encountering water when digging.
- C. Should Contractor claim that any instruction, request, drawing, specification, action, condition, omission, default or other situation (i) obligates the District to increase the GMP; or (ii) obligates the District to grant an extension of time for the completion of this Agreement; or (iii) constitutes a waiver of any provision in this Agreement, CONTRACTOR SHALL NOTIFY THE DISTRICT, IN WRITING, OF SUCH CLAIM AS SOON AS POSSIBLE, BUT IN NO EVENT WITHIN MORE THAN TEN (10) DAYS FROM THE DATE CONTRACTOR HAS ACTUAL OR CONSTRUCTIVE NOTICE OF THE CLAIM. CONTRACTOR SHALL ALSO PROVIDE THE DISTRICT WITH SUFFICIENT WRITTEN DOCUMENTATION SUPPORTING THE FACTUAL BASIS OF THE CLAIM including items used in valuing said claim. Contractor shall be required to certify under penalty of perjury the validity and accuracy of any claims submitted. Contractor's failure to notify the District within such ten (10) day period shall be deemed a waiver and relinquishment of the claim against the District.
- D. Expenses of reconstruction and/or costs to replace and/or repair damaged materials and supplies, provided that Contractor is not fully compensated for such expenses and/or costs by insurance or otherwise, shall be included in an increase to the GMP if said expenses are the result of the negligent acts or omissions of the District, or its principals, agents, servants, or employees.

SECTION 11. NOT USED

SECTION 12. PERSONNEL ASSIGNMENT

- A. Contractor shall assign **Carl Magness** as Project Manager/Superintendent for the Project. So long as **Carl Magness** remains in the employ of Contractor, such person shall not be changed or substituted from the Project, or cease to be fully committed to the Project except as provided in this Section. In the event Contractor deems it necessary, Contractor shall replace the manager and/or the superintendent for the Project with a replacement with like qualifications and experience, subject to the prior written consent of the District, which consent shall not be unreasonably withheld. Any violation of the terms of paragraph A of this Section 12 shall entitle the District to terminate this Agreement for breach, pursuant to the provisions of the General Conditions.
- B. Notwithstanding the foregoing provisions of paragraph A of Section 12, above, if any manager and/or superintendent proves not to be satisfactory to the District, upon written notice from the District to Contractor, such person(s) shall be promptly replaced by a person who is acceptable to the District in accordance with the following procedures: Within five (5) business days after receipt of a notice from the District requesting replacement of any manager and/or superintendent or discovery by Contractor that any manager and/or superintendent is leaving their employ, as the case may be, Contractor shall provide the District with the name of an acceptable replacement/substitution together with such information as the District may reasonably request about such replacement/substitution. The replacement/substitution shall commence work on the Project no later than five (5) business days following the District's approval of such replacement, which approval shall not be unreasonably withheld. If the District and Contractor cannot agree as to the replacement/substitution, the District shall be entitled to terminate this Agreement for breach pursuant to the provisions of the General Conditions.

SECTION 13. BONDING REQUIREMENTS

Contractor shall fully comply with the requirements set forth in Section 6.9 of the General Conditions.

SECTION 14. PAYMENTS TO CONTRACTOR

- A. Contractor shall finance the cost of construction of the Project which costs shall not exceed the GMP, which shall not be adjusted except as otherwise provided in this Agreement. The District shall pay Contractor Tenant Improvement Payments and Sublease Payments pursuant to the terms and conditions of Section 6 of the Sublease. In the event of a dispute between the District and Contractor, the District may withhold from the Tenant Improvement Payments and the Sublease Payments an amount not to exceed one hundred fifty percent (150%) of the disputed amount.

- B. This Agreement is subject to the provisions of California Public Contract Code Sections 7107, 7201 and 20104.50 as they may from time to time be amended.
- C. For purposes of this Agreement, the acceptance by the District means acceptance made only by an action of the governing body of the District in session. Acceptance by Contractor of the final Tenant Improvement Payment or the Sublease Payment, as the case may be, shall constitute a waiver of all claims against the District related to those amounts.

SECTION 15. CONTRACTOR'S CONTINUING RESPONSIBILITY

Neither the final payment nor any provision in the Contract Documents shall relieve Contractor of responsibility for faulty materials or workmanship incorporated in the Project or for any failure to comply with the requirements of the Contract Documents.

SECTION 16. INSURANCE

Contractor shall provide, during the life of this Agreement, the types and amounts of insurance set forth in Article 6 of the General Conditions, which are incorporated by reference herein.

SECTION 17. USE OF PREMISES

Contractor shall confine operations at the Site to areas permitted by law, ordinances, permits and the Construction Documents and shall not unreasonably encumber the Site or existing School Facilities at the Site with any materials or equipment. Contractor shall not load or permit any part of the work to be loaded with a weight so as to endanger the safety of persons or property at the Site.

SECTION 18. SITE REPRESENTATIONS

The District warrants and represents that the District has, and will continue to retain at all times during the course of construction, legal title to the Site and that said land is properly subdivided and zoned so as to permit the construction and use of said Site with respect to the Project. The District further warrants and represents that title to said land is free of any easements, conditions, limitation, special permits, variances, agreements or restrictions which would prevent, limit or otherwise restrict the construction or use of said Site pursuant to this Agreement. Reference is made to the fact that the District has provided information on the Site to Contractor. Such information shall not relieve Contractor of its responsibility; and the interpretation of such data regarding the Site, as disclosed by any borings or other preliminary investigations, is not warranted or guaranteed, either expressly or implicitly, by the District. Contractor shall be responsible for having ascertained pertinent local conditions such as location,

#17-117

accessibility and general character of the Site and for having satisfied itself as to the conditions under which the work is to be performed. No claim for any allowances because of Contractor's error or negligence in acquainting itself with the conditions at the Site will be recognized.

SECTION 19. HAZARDOUS WASTE AND UNKNOWN PHYSICAL CONDITIONS

Contractor shall comply with the District's Hazardous Materials Procedures and Requirements as set forth herein.

- A. If the District has identified the presence of hazardous materials on or in proximity to the Site (the "Pre-existing Hazardous Materials"), Contractor shall review all information provided by the District that characterizes the Pre-existing Hazardous Materials and shall take the actions approved by DTSC and issued by the District necessary to address the Pre-existing Hazardous Materials in the performance of the work. Contractor shall conduct the work based on this information issued at the time contract documents are executed. Contractor shall immediately communicate, in writing, any variances from available information to the District.
- B. The District will retain an additional independent environmental consultant to perform the investigation, inspection, testing, assessment, sampling and analysis necessary to prepare and recommend a remediation plan for the Pre-existing Hazardous Materials for the District's approval (the "Remediation Plan").
- C. The District will retain title to all Pre-existing Hazardous Materials encountered during the work. This does not include hazardous material generated by Contractor, including but not limited to used motor oils, lubricants, cleaners, etc. Contractor shall dispose of such hazardous waste in accordance with the provisions of the Contract Documents, as well as local, State and Federal laws and regulations. The District will be shown as the hazardous waste generator and will sign all hazardous waste shipment manifests for non-Contractor generated hazardous waste. Nothing contained within these Contract Documents shall be construed or interpreted as requiring Contractor to assume the status of owner or generator of hazardous waste substances for non-Contractor generated hazardous wastes.
- D. Except as otherwise provided herein, it is the responsibility of Contractor to obtain governmental approvals relating to Hazardous Materials Management, including Federal and State surface water and groundwater discharge permits and permits for recycling and reuse of hazardous materials for all work noted in the contract documents. Contractor shall be responsible for coordinating compliance with such governmental approvals and applicable governmental rules with the District's hazardous materials consultant, including those governing the preparation of waste profiles, waste manifests, and bills of lading. If Contractor encounters hazardous materials, it shall immediately notify the District in writing. The District, Consultant and

- 13 -

#17-117

Contractor shall jointly establish the plan for disposition and actions to be taken with respect to the hazardous materials, subject to final written approval by the District.

E. If, during construction, Contractor encounters materials, conditions, waste, contaminated groundwater or substances, not identified in the District's assessment report, that Contractor reasonably suspects are hazardous materials, Contractor shall stop the affected portion of the work, secure the area, promptly notify the District, and take reasonable measures to mitigate the impact of such work stoppage. The District shall retain the services of an environmental consultant to perform investigation, inspection, testing, assessment, sampling and analysis of the suspect materials, conditions, waste, groundwater or substances.

(1) Found Not to be Hazardous Materials. If the environmental consultant determines that the materials, conditions, waste, contaminated groundwater or substances do not constitute hazardous materials, Contractor shall recommence the suspended work.

(2) Found to be Hazardous Materials. If the environmental consultant determines that the materials, conditions, waste, contaminated groundwater or substances constitute hazardous materials and such hazardous materials require remediation and disposal, then the District, Consultant and Contractor shall jointly establish the plan for disposition and actions to be taken with respect to the hazardous materials, subject to final written approval by the District. All such costs shall be the responsibility of the District.

F. Exacerbation of Pre-Existing Hazardous Materials.

If during construction Contractor encounters pre-existing environmental conditions that it knew or should have known involve hazardous materials (the "Point of Discovery") (which encounters may include an unavoidable release or releases of hazardous materials) then Contractor must immediately stop the affected portion of the work. If Contractor fails to immediately stop the affected portion of the work after the Point of Discovery, then Contractor is solely responsible for any resultant Exacerbation Cost. "Exacerbate," in all its forms, means the worsening effects of Contractor's failure to stop the affected portion of work after the Point of Discovery. "Exacerbation Cost" means the differential between (i) the actual increase in the cost of remediation and delays to the Project attributable to pre-existing environmental conditions involving hazardous substances, and (ii) the cost thereof or delays thereto had Contractor immediately stopped the affected portion of the work after the Point of Discovery. The standard of "should have known" applies to Contractor's supervisory personnel, whether or not on the Site. Contractor's supervisory personnel must have had the hazardous material training required by applicable OSHA and Cal OSHA rules or regulations.

- 14 -

SECTION 20. INDEPENDENT CONTRACTOR

- A. Contractor is retained as an independent contractor and is not employed by the District. No employee or agent of Contractor shall become, or be considered to be, an employee of the District for any purpose. It is agreed that the District is interested only in the results obtained from service under this Agreement and that Contractor shall perform as an independent contractor with sole control of the manner and means of performing the services required under this Agreement. Contractor shall complete this Agreement according to its own methods of work which shall be in the exclusive charge and control of Contractor and which shall not be subject to control or supervision by the District except as to results of the work. It is expressly understood and agreed that Contractor and its employees shall in no event be entitled to any benefits to which the District employees are entitled, including, but not limited to, overtime, retirement benefits, insurance, vacation, worker's compensation benefits, sick or injury leave or other benefits.
- B. Contractor shall be responsible for all salaries, payments, and benefits for all of its officers, agents, and employees in performing services pursuant to this Agreement.

SECTION 21. ACCOUNTING RECORDS

Contractor, and all Subcontractors, shall check all materials, equipment and labor entering into the work and shall keep or cause to be kept such full and detailed accounts as may be necessary for proper financial management under this Agreement, including true and complete books, records and accounts of all financial transactions in the course of their activities and operations related to the Project. These documents include sales slips, invoices, payrolls, personnel records, requests for Subcontractor payment, and other data relating to all matters covered by the Contract Documents (the "Data"). The Data shall be maintained for ten (10) years from the latest expiration of the term (as such may be extended) of any of the Contract Documents. Contractor shall use its best efforts to cause its Subcontractors to keep or cause to be kept true and complete books, records and accounts of all financial transactions in the course of its activities and operations related to the Project. Upon completion of the Project, Contractor shall provide the District with one (1) complete copy of the Data.

The District, at its own costs, shall have the right to review and audit, upon reasonable notice, the books and records of Contractor and any Subcontractors concerning any monies associated with the Project.

SECTION 22. PERSONAL LIABILITY

Neither the trustees, officers, employees, or agents of District, the District's representative, or Architect shall be personally responsible for any liability arising under the Contract Documents.

SECTION 23. AGREEMENT MODIFICATIONS

No waiver, alteration or modification of any of the provisions of this Agreement shall be binding upon either the District or Contractor unless the same shall be in writing and signed by both the District and Contractor.

SECTION 24. NOTICES

Any notices or filings required to be given or made under this Agreement shall be served, given or made in writing upon the District or Contractor, as the case may be, by personal delivery or registered mail (with a copy sent via fax or regular mail) to the respective addresses given below or at such other address as such party may provide in accordance with the provisions herein. Any change in the addresses noted herein shall not be binding upon the other party unless preceded by no less than thirty (30) days prior written notice.

If to Contractor:

Bernards
555 First Street
San Fernando, CA 91340
Attn: Rick Fochtman

If to the District:

Oxnard School District
1051 South A Street
Oxnard, California 93030
Attn: Dr. Cesar Morales, Superintendent

With a copy to Nitasha Sawhney,
Garcia, Hernandez, Sawhney & Bermudez LLP
2490 Mariner Square Loop, Suite 140
Alameda, CA 94501

And with an additional copy to Scott Burkett,
Caldwell Flores Winters, Inc.
6425 Christie Ave., Suite 270
Emeryville, CA 94608

Notices under this Agreement shall be deemed to have been given, and shall be effective upon actual receipt by the other parties, or, if mailed, upon the earlier of the fifth (5th) day after mailing or actual receipt by the other party.

SECTION 25. ASSIGNMENT

Neither party to this Agreement shall assign this Agreement or sublet it as a whole without the written consent of the other, nor shall Contractor assign any monies due or to become due to it hereunder without the prior written consent of the District.

SECTION 26. PROVISIONS REQUIRED BY LAW

Each and every provision of law and clause required to be inserted in these Contract Documents shall be deemed to be inserted herein and the Contract Documents shall be read and enforced as though it were included herein, and if through mistake or otherwise any such provision is not inserted or is not inserted correctly, then upon application of either party the Contract Documents shall forthwith be physically amended to make such insertion or correction.

SECTION 27. HEADINGS

The headings in this Agreement are inserted only as a matter of convenience and reference and are not meant to define, limit or describe the scope or intent of the Contract Documents or in any way to affect the terms and provisions set forth herein.

SECTION 28. APPLICABLE LAW

This Agreement shall be governed by and construed in accordance with the laws of the State of California. The parties irrevocably agree that any action, suit or proceeding by or among the District and Contractor shall be brought in whichever of the Superior Courts of the State of California, Ventura County, or the Federal Court for the Central District of California in Los Angeles, California, has subject matter jurisdiction over the dispute and waive any objection that they may now or hereafter have regarding the choice of forum whether on personal jurisdiction, venue, forum non conveniens or on any other ground.

SECTION 29. SUCCESSION OF RIGHTS AND OBLIGATIONS

All rights and obligations under this Agreement shall inure to and be binding upon the successors and assigns of the parties hereto.

SECTION 30. NOTIFICATION OF THIRD PARTY CLAIMS

The District shall provide Contractor with timely notification of the receipt by the District of any third-party claim relating to this Agreement, and the District may charge back to Contractor the cost of any such notification.

SECTION 31. SEVERABILITY

If any one or more of the terms, covenants or conditions of this Agreement shall to any extent be declared invalid, unenforceable, void or voidable for any reason whatsoever by a court of competent jurisdiction, the finding or order or decree of which becomes final, none of the remaining terms, provisions, covenants and conditions of the Contract Documents shall be affected thereby, and each provision of the Contract Documents shall be valid and enforceable to the fullest extent permitted by law.

SECTION 32. ENTIRE AGREEMENT

This Construction Services Agreement and the additional Contract Documents as defined in paragraph C of Section 1 herein, including the Site Lease, the Sublease, and the Specifications, drawings, and plans constitute the entire agreement between Contractor and the District. The Contract Documents shall not be amended, altered, changed, modified or terminated without the written consent of both parties hereto, except as otherwise provided in Section 10 hereof.

SECTION 33. EXECUTION IN COUNTERPARTS

This Agreement may be executed in any number of counterparts, each of which shall be an original, but all of which together shall constitute one instrument.

IN WITNESS, WHEREOF the parties hereto, intending to be legally bound thereby, have executed this Agreement effective as of the date first above written.

CONTRACTOR

Bernards
By: Rick Fochtman

By: Rick Falt
Title: Executive Vice President
Date: 8/29/2017

THE DISTRICT

Oxnard School District,
a California school district
By: Lisa A. Franz, Director, Purchasing

By: Lisa A. Franz
Title: Director, Purchasing
Date: 9-7-17

#17-117

EXHIBIT A

Scope of Work (Plans & Specifications)

Marshall New Classroom Building

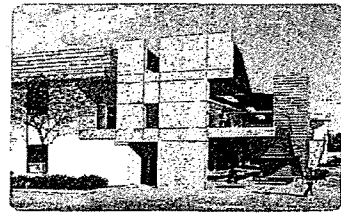
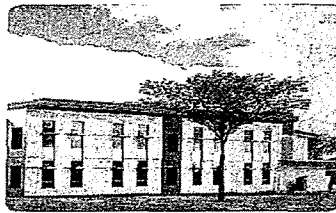
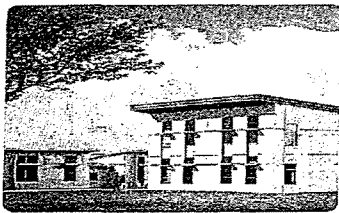

100% Construction Documents Package

Oxnard School District

October 4, 2016

FEB. 17 2017
DCA A# 03 - 114806

BINDER A



Oxnard School District
Marshall New Classroom Building
2900 Thurgood Marshall Dr. Oxnard, CA 93036

CSDA | DESIGN
GROUP

#17-117

EXHIBIT A, continued

BIDDING DOCUMENTS TABLE OF CONTENTS

VOLUME 1 of 2 (Not submitted to DSA)

DIVISION 00 - PROCUREMENT AND CONTRACTING REQUIREMENTS

00 2150	List of Subcontractors
00 2400	Statement of Bidder's Qualifications
00 2600	Bid Bond
00 4000	Labor and Material Payment Bond
00 4100	Performance Bond
00 4150	Certificate of Worker's Compensation Insurance
00 5100	Background Check and Fingerprinting Procedures for Contractors
00 5300	Guarantee and Standard Forms
00 7000	General Conditions

DIVISION 1 -- 2 (Not Used)

Volume 2 of 2

DIVISION 03 - CONCRETE

03 1000	Concrete Forming Accessories
03 2000	Concrete Reinforcing
03 3000	Cast-In-Place Concrete

DIVISION 04 - MASONRY

04 2200	Concrete Unit Masonry
---------	-----------------------

DIVISION 05 - METALS

05 1200	Structural Steel Framing
05 5000	Metal Fabrications

DIVISION 06 - WOOD, PLASTICS, AND COMPOSITES

06 1000	Rough Carpentry
06 1733	Wood I-Joists
06 1813	Glued Laminated Beams
06 4000	Architectural Woodwork

TABLE OF CONTENTS

MARSHALL NEW CLASSROOM BUILDING

- 20 -

OXNARD SCHOOL DISTRICT

CONSTRUCTION SERVICES AGREEMENT

Marshall New Classroom Building Project

August 24th, 2017

#17-117

EXHIBIT A, continued

DIVISION 07 - THERMAL AND MOISTURE PROTECTION

07 1326 Self Adhering Sheet Wang
07 2100 Thermal Insulation
074000 Metal Roof Panels
075416 Polyvinyl Chloride (PVC) Roofing
076000 Flashing Sheet Metal
078400 Fire Stop and Smoke Seals
079200 Joint Sealants

DIVISION 08 - OPENINGS

08 1113 Hollow Metal Doors and Frames
08 1416 Flush Wood Doors
08 3116 Access Panels and Frames
08 3613 Sectional Doors
08 5113 Aluminum Windows
08 7100 Door Hardware
08 8000 Glazing

DIVISION 09 - FINISHES

09 2200 Cement Plastering
09 2900 Gypsum Board
09 3013 Ceramic Tiling
09 5123 Acoustical Tile Ceilings
09 6513 Rubber Base
09 6519 Resilient Tile Flooring
09 9000 Paints and Coatings

DIVISION 10 - SPECIALTIES

101400 Signage
102113.17 Phenolic-Core Shower and Dressing Compartments
102800 Toilet Accessories
105200 Fire Extinguishers

DIVISION 11 - EQUIPMENT

116800 Playfield Equipment and Structures

TABLE OF CONTENTS

MARSHALL NEW CLASSROOM BUILDING

- 21 -

OXNARD SCHOOL DISTRICT

CONSTRUCTION SERVICES AGREEMENT

Marshall New Classroom Building Project

August 24th, 2017

EXHIBIT A, continued



DIVISION 12 - FURNISHINGS

- 12 2413 Roller Window Shades
- 12 3553 Manufactured Plastic-Laminate-Faced Casework

DIVISION 13 (Not Used)

DIVISION 14 - CONVEYING EQUIPMENT

- 14 2123 Machine-Room-Less Electric Traction Passenger Elevators

DIVISION 15 – 20 (Not Used)

DIVISION 21 - FIRE SUPPRESSION

- 21 1000 Fire Protection

DIVISION 22 – PLUMBING



- 22 0500 Basic Materials and Methods
- 22 0553 Identification
- 22 0700 Insulation
- 22 0800 Equipment and Systems Tests
- 22 1100 Domestic and Industrial Water Systems
- 22 1300 Drainage System
- 22 4000 Plumbing Fixtures

DIVISION 23 – HEATING, VENTILATION, AND AIR CONDITIONING (HVAC)

- 23 0000 General Provisions
- 23 0513 Electric Motors and Controllers
- 23 0548 Vibration Isolation and Seismic Restraints
- 23 2500 Water Treatment
- 23 3100 Air Transmission and Distribution System
- 23 8000 Air Conditioning and Air Handling Equipment
- 23 9000 Building Management System

DIVISION 24 – 25 (Not Used)



DIVISION 26 - ELECTRICAL

- 26 0126 Inspection Test and Acceptance

TABLE OF CONTENTS
MARSHALL NEW CLASSROOM BUILDING

EXHIBIT A, continued

26 0500	Common Work Results for Electrical
26 0513	Basic Electrical Materials and Methods
26 0519	Low-Voltage Wires (600 Volt AC)
26 0526	Grounding and Bonding
26 0533	Raceways and Boxes Fitting and Supports
26 0586	Motors and Drives
26 0800	Electrical Systems Commissioning
26 0923	Lighting Control Systems
26 1000	Service Entrance
26 2200	Low-Voltage Transformers
26 2413	Switchboards1000
26 2416	Panelboards and Signal Terminal Cabinets
26 2419	Motor Control Devices
26 5000	Lighting
26 5200	Emergency Power Systems

DIVISION 27 - COMMUNICATIONS

27 0126	Test and Acceptance Requirements for Structured Cabling
27 1013	Structured Cabling
27 4113	Classroom Sound Enhancement System
27 5116	Public Address and Intercommunication Systems
27 5313	Clock and Program Systems

DIVISION 28 – ELECTRONIC SAFETY AND SECURITY

28 1600	Intrusion Detection System
28 3100	Fire Detection and Alarm System

DIVISION 29 – 30 (Not Used)

DIVISION 31 – EARTHWORK

31 1000	Site Clearing
31 2200	Grading
31 2316	Excavation and Fill Paving
31 2319	Excavation and Fill Structures
31 2323	Excavation and Fill Utilities
31 2326	Base Course

TABLE OF CONTENTS

MARSHALL NEW CLASSROOM BUILDING

#17-117

EXHIBIT A, continued

DIVISION 32 – EXTERIOR IMPROVEMENTS



32 0117	Pavement Repair
32 1216	Asphalt Paving
32 1236	Seal for Bituminous Surfacing
32 1313	Site Concrete Work

DIVISION 33 – SITE IMPROVEMENTS

33 1100	Site Water Distribution Utilities
33 3000	Site Sanitary Sewer Utilities
33 4000	Storm Drainage Utilities



TABLE OF CONTENTS
MARSHALL NEW CLASSROOM BUILDING

- 24 -

OXNARD SCHOOL DISTRICT

CONSTRUCTION SERVICES AGREEMENT

Marshall New Classroom Building Project

August 24th, 2017

EXHIBIT A, continued

<p>100% DISTRICT SUBMITTAL MARSHALL NEW CLASSROOM BUILDING <small>2950 THURGOOD MARSHALL DR. OXNARD, CA 93036</small> OXNARD SCHOOL DISTRICT</p>	<p>VOLUME I</p>
<p>DSA FILE NO. 56-22</p>	<p>DSA APPLICATION NO. 03-116806</p>
<p>PTN NO. 72538-91</p>	

DRAWING INDEX

VOLUME I	VOLUME II	
<p>01- GENERAL</p> <p>G - 001 COVER SHEET, INDEX, SCOPE OF WORK, VICINITY MAP G - 002 GENERAL NOTES, ABBREVIATIONS, SYMBOL LEGEND</p> <p>G - 003 FIRE LIFE SAFETY SITE PLAN G - 004 ACCESSIBILITY SITE PLAN G - 005 BUILDING CODE ANALYSIS G - 006 SIGNAGE & FIRE EXTINGUISHER PLANS</p> <p>6</p> <p>03-CIVIL</p> <p>C-001 GENERAL NOTES C-002 LEGEND AND ABBREVIATIONS C-101 DEMOLITION PLAN C-102 DEMOLITION PLAN C-103 DEMOLITION PLAN C-201 SITE CONTROL PLAN C-202 SITE CONTROL PLAN C-203 SITE CONTROL PLAN C-204 STRIPING PLAN C-300 COMPOSITE GRADING PLAN C-301 ENLARGED GRADING PLAN C-302 ENLARGED GRADING PLAN C-303 GRADING SECTIONS C-304 GRADING SECTIONS C-401 SITE UTILITY PLAN C-402 SITE UTILITY PLAN C-403 SITE UTILITY PROFILE C-404 SITE UTILITY PROFILE C-701 MISCELLANEOUS DETAILS C-702 MISCELLANEOUS DETAILS C-703 MISCELLANEOUS DETAILS C-704 MISCELLANEOUS DETAILS</p> <p>22</p> <p>04- LANDSCAPE</p> <p>L - 1 IRRIGATION PLAN L - 2 PLANTING PLAN L - 3 IRRIGATION & PLANTING DETAILS L - 4 IRRIGATION & PLANTING SPECIFICATIONS</p> <p>4</p> <p>05- STRUCTURAL</p> <p>S-101 GENERAL NOTES S-101A GENERAL NOTES & ABBREVIATIONS S-211 FOUNDATION PLAN S-212 2ND FLOOR FRAMING PLAN S-213 ROOF FRAMING PLAN S-214 CANOPY ROOF FRAMING PLAN S-400 TYPICAL CONCRETE DETAILS S-400A TYPICAL CONCRETE DETAILS S-401 FOUNDATION DETAILS S-600 TYPICAL WOOD DETAILS S-600A TYPICAL WOOD DETAILS S-600B TYPICAL WOOD DETAILS S-600C TYPICAL WOOD DETAILS S-600D TYPICAL WOOD DETAILS S-800E WALL ELEVATION AND DETAILS S-800F WALL ELEVATION AND DETAILS S-700 FRAMING DETAILS S-700A ELEVATOR DETAILS S-700B STAIR PLANS & DETAILS</p> <p>19</p>	<p>06- ARCHITECTURAL</p> <p>A - 101 SITE PLAN A - 102 ENLARGED SITE PLAN A - 103 ENLARGED SITE PLAN A - 104 SITE DETAILS A - 105 SITE DETAILS</p> <p>A - 111 FIRST FLOOR PLAN A - 112 SECOND FLOOR PLAN</p> <p>A - 121 FIRST FLOOR REFLECTED CEILING PLAN A - 122 SECOND FLOOR REFLECTED CEILING PLAN</p> <p>A - 131 ROOF PLAN</p> <p>A - 210 EXTERIOR ELEVATIONS A - 211 EXTERIOR ELEVATIONS</p> <p>A - 220 INTERIOR ELEVATIONS A - 221 INTERIOR ELEVATIONS A - 222 INTERIOR ELEVATIONS A - 223 INTERIOR ELEVATIONS A - 224 TOILET INTERIOR ELEVATIONS</p> <p>A - 310 BUILDING SECTIONS A - 311 BUILDING SECTIONS</p> <p>A - 320 WALL SECTIONS A - 321 WALL SECTIONS A - 322 WALL SECTIONS</p> <p>A - 410 ENLARGED FLOOR PLANS A - 411 ENLARGED FLOOR PLANS</p> <p>A - 420 VERTICAL CIRCULATION PLANS & SECTIONS A - 421 VERTICAL CIRCULATION PLANS & SECTIONS</p> <p>A - 500 ROOF DETAILS A - 501 ROOF DETAILS</p> <p>A - 510 EXTERIOR ENVELOPE DETAILS</p> <p>A - 520 WINDOW/DOOR DETAILS A - 521 DOOR DETAILS</p> <p>A - 530 INTERIOR DETAILS A - 531 INTERIOR DETAILS A - 535 TOILET DETAILS</p> <p>A - 540 CEILING DETAILS</p> <p>A - 550 SIGNAGE DETAILS</p> <p>A - 560 STAIR DETAILS A - 561 ELEVATOR DETAILS</p> <p>A - 570 CASEWORK DETAILS</p> <p>A - 610 DOOR SCHEDULE A - 612 FINISH SCHEDULE</p> <p>A - 620 WALL TYPES</p> <p>27</p>	<p>E-041 PANEL SCHEDULES E-050 ELECTRICAL DETAILS E-090 SIGNAL SYSTEM RISER DIAGRAMS E-101 SITE PLAN - ELECTRICAL E-102 ENLARGED SITE PLAN - ELECTRICAL E-201 FIRST FLOOR PLAN - LIGHTING E-202 FIRST FLOOR PLAN - POWER E-203 FIRST FLOOR PLAN - SIGNAL E-204 FIRST FLOOR PLAN - FIRE ALARM E-301 SECOND FLOOR PLAN - LIGHTING E-302 SECOND FLOOR PLAN - POWER E-303 SECOND FLOOR PLAN - SIGNAL E-304 SECOND FLOOR PLAN - FIRE ALARM E-401 ROOF PLAN - ELECTRICAL</p> <p>29</p> <p>10- PLUMBING</p> <p>P-001 LEGENDS, NOTES, AND SCHEDULES P-101 PLUMBING SITE PLAN P-111 FIRST FLOOR PLAN P-112 SECOND FLOOR PLAN P-131 ROOF PLAN P-411 ENLARGED FLOOR PLAN P-511 PLUMBING DETAILS</p> <p>7</p> <p>11- FIRE PROTECTION</p> <p>FP - 001 SITE PLAN & NOTES FP - 002 FIRST FLOOR PLAN FP - 003 SECOND FLOOR PLAN FP - 004 BUILDING SECTIONS FP - 005 MISCELLANEOUS DETAILS</p> <p>5</p> <p>Grand total: 140</p>

EXHIBIT A, continued

19
Volume I total: 51

A - 001 WALL TYPES	
42	
08-MECHANICAL	
M-001	LEGENDS, NOTES, AND SCHEDULES
M-111	FIRST FLOOR PLAN
M-112	SECOND FLOOR PLAN
M-131	ROOF PLAN
M-510	MECHANICAL DETAILS
M-521	VIBRATION ISOLATOR DETAILS
M-601	ENERGY COMPLIANCE FORMS
M-602	ENERGY COMPLIANCE FORMS
M-603	ENERGY COMPLIANCE FORMS
9	
09-ELECTRICAL	
E-001	SYMBOL LIST, ABBREVIATIONS & NOTES
E-002	GENERAL ELECTRICAL NOTES
E-010	FIXTURE LIST & TITLE 24 CALCULATIONS
E-011	TITLE 24 CALCULATIONS - INDOOR LIGHTING
E-012	TITLE 24 CALCULATIONS - OUTDOOR LIGHTING
E-013	TITLE 24 CALCULATIONS - INDOOR LIGHTING
E-014	TITLE 24 CALCULATIONS - OUTDOOR LIGHTING
E-015	LIGHTING CONTROL INFORMATION
E-016	LIGHTING CONTROL INFORMATION
E-020	FIRE ALARM INFORMATION
E-021	FIRE ALARM CALCULATIONS
E-022	FIRE ALARM RISER DIAGRAM
E-030	SINGLE LINE DIAGRAM
E-031	SWITCHBOARD ELEVATIONS
E-040	PANEL SCHEDULES

Exhibit B

Guaranteed Maximum Price (GMP)



SCHEDULE OF VALUES

Marshall Classroom Building
 Oxnard School District
 2900 Thurgood Marshall Dr, Oxnard, CA 93036

GMP
 July 20, 2017

	Description	Recommended Subcontractor	Amount
01570	Erosion Control	Socal Stormwater Runoff Solution	78,677
01730	Surveying	Michael Baker International	20,900
03200	Reinforcing Steel	Vista Steel	96,970
03300	Cast In Place Concrete	Santa Clarita Concrete	413,131
05120	Structural Steel & Misc. Metals	C.A. Buchen	294,133
05700	Ornamental Metals		w/ Struct Steel
06100	Rough Carpentry	JF Construction	1,067,965
06200	Millwork / Cabinetry / Countertops	Dennis Reeves Inc.	34,161
07140	Waterproofing / Traffic Coating	Systems WP	63,636
07200	Insulation	Alcal	47,851
07540	Roofing	Best Contracting	118,535
07600	Sheet Metal / Metal Roofing	Merit Metal Products	160,900
08100	Doors / Frames / Hardware	Construction Hardware	110,110
08800	Glass and Glazing	Santa Barbara Glass	114,087
09220	Plaster & Drywall	Church and Larsen	538,346
09300	Ceramic Tile	Silverado Tile	51,120
09510	Acoustical Ceilings & Wall Panels	Prime Acoustics	48,320
09650	Resilient Flooring and Carpet	Reliable Flooring	69,611
09900	Painting	Vanguard	102,192
10000	Building Specialties	Various	55,645
10110	Visual Display Boards	Nelson Adams Naco Inc.	148,359
10140	Signage	AGS	12,625
10280	Toilet Partitions / Bathroom Accessories	YTI Enterprises	29,000
12240	Window Shades	A1 Quality Blinds	10,000
	Final Cleaning	Commercial Const Cleaning	26,050
14200	Elevators	Republic Elevator	90,220
21000	Fire Sprinkler	J.G. Tate Fire Protection	143,456
22000	Plumbing	City Commerical	355,312
23000	HVAC	Sheldon Mechanical	366,968
26000	Electrical / Low Voltage	Taft Electric	1,177,480
31220	Demo, Earthwork and Site Clearing	Damar Const.	176,464
32122	Asphalt Paving	Onyx Paving	48,580
32131	Site Concrete	B&M Contractors	147,475
32800	Playground Surfaces & Equipment	SpectraTurf / Miracle Playground	100,262
32900	Landscape and Irrigation	Dufau Landscape	81,345



SCHEDULE OF VALUES

Marshall Classroom Building
 Oxnard School District
 2900 Thurgood Marshall Dr, Oxnard, CA 93036

GMP
 July 20, 2017

Description		Recommended Subcontractor	Amount
33000	Site Utilities	Sam Hill & Sons	210,055
01000	Allowances		85,000
	Subguard	1.20%	80,339

Subcontracted Direct Costs			\$ 6,775,280
-----------------------------------	--	--	---------------------

	General Conditions		1,287,702
	General Requirements		3,250
	Subtotal		8,066,232

	Contractor Controlled Insurance Program	1.25%	100,828
	Builders Risk Insurance		By Owner
	General Contractor Bond	0.85%	69,420
	Subtotal		8,236,479

	Contractor Fee	5.00%	411,824
	Subtotal		8,648,303

	Contractor Contingency	4.00%	345,932
--	------------------------	-------	---------

Total Contract Amount			\$ 8,994,236
------------------------------	--	--	---------------------



ALLOWANCES

Marshall Classroom Building

Oxnard School District

2900 Thurgood Marshall Dr, Oxnard, CA 93036

GMP

July 20, 2017

Allowances Included in Proposal		
1	Natural gas service line.	\$ 50,000
2	Furnish and install new Gate G assembly including hardware	\$ 10,000
3	Temporary power during SCE electrical service switch-over in Summer of 2018.	\$ 25,000
TOTAL ALLOWANCES		\$ 85,000



QUALIFICATIONS & ASSUMPTIONS

Marshall Classroom Building

Oxnard School District

2900 Thurgood Marshall Dr, Oxnard, CA 93036

GMP

July 20, 2017

The following items provide additional clarifications regarding the scope of work included in the Proposal:	
1	All Testing and inspection including shop inspection. All testing and inspection will be performed by the authority having jurisdiction or a third party hired by the owner.
2	GMP excludes all permanent connection or use fees by outside utility companies.
3	Settlement surveys of adjacent properties or utilities are excluded.
4	Owner's FFE items - GMP does not include furnishing, installation, unloading / hoisting or storage of Owner's FF&E.
5	Metalworks Linear Faceted/Curved Ceiling system 8" panel per Note 9.03/G-006, see detail 4/A-541 (no sheet A-541 provided) at Elevators, is excluded.
6	Does not include Owner's mobile shelf units, rolling desks, or similar non-fixed furniture.
7	Natural gas service line to new building not shown on Site Utility Plan C-401,402,403,404 or P-sheets is not included, but is addressed by allowance.
8	Using Metal Sales Standing Seam roof in lieu of AEP Span Span-Lock per specifications.
9	Window blinds are not included at the sectional doors, only at the classroom windows even though they are not shown.
10	Epoxy grout is not included at ceramic tile.
11	Vapor emission treatment at concrete floors is not included.
12	TV brackets are OFCI. Televisions or monitors are not included.
13	Specification Section 23 25 00 - Water Treatment is excluded.
14	Hazardous or contaminated soils handling or removal, or removal of any existing underground tanks or appurtenances, is excluded.
15	No standing guard service is included for school site during the Edison rework of the main power. District to provide guard service.
16	Existing handball walls will be demolished (total of 5). GMP does not include any replacement of these ball walls.
17	GMP does not include any seal and re-stripe of existing asphalt play courts - not shown on plans.

VALUE ENGINEERING COST TRACKING LOG

Marshall Classroom Building

Oxnard School District

2900 Thurgood Marshall Dr, Oxnard, CA 93036

July 19, 2017

CCD Required	NO	COST TRACKING DESCRIPTION	NEXT ACTION/STEP/COMMENTS
		Building	
CCD	ARC.1	Replace 8'6"x13' sectional roll up doors with smaller sized aluminum glazed window frames and plaster walls	<p>JA to prepare elevation replace (10) sectional OH doors with windows in punched openings of a plaster wall and drywall wall</p> <p>Update 06/23/17: Sketched due 06/30/17</p> <p>Update 7/6/17: Sketches received from CSDA and circulated to subs for pricing. Requested responses by no later than 7/10/17.</p> <p>Update 7/18/17: Clarification to aluminum window type and glass type received from CSDA and subs have provided their proposals.</p>
CCD	ARC.2	Eliminate Smoke Containment doors at elevators, possibly not required	<p>JA to call FLS plan checker to determine if these can be eliminated.</p> <p>Update 06/23/17: CCD-A to delete smoke doors shall be prepared by 06/30/17 and submitted when DSA Box is set up.</p>
	ARC.3	Eliminate sliding markerboards, keep recessed wall space for mobile shelf units.	<p>After discussion with the team this part of the programmatic design which cannot be eliminated. TM to work with bidders on how to reduce the cost of the current design</p> <p>Update 06/23/17: TM is working with Nelson Adams to achieve projected savings without impacting this programmatic element</p> <p>Update 7/6/17: Revised pricing received from Nelson Adams for sliding markerboards @ 6' in height, same widths as shown on interior elevations. VE credit combined with ARC.4</p> <p>Additional cost for painting exposed wall surfaces are combined with ARC.3</p>
	ARC.4	Decrease size of floor to ceiling markerboard and tackboard surfaces	<p>JA to prepare revised elevation to reduce the height of the wall mounted markerboards and acoustical tackboard</p> <p>Update 06/23/17: TM is working with Nelson Adams to achieve projected savings without impacted this programmatic element</p> <p>Update 7/6/17: Revised pricing received for wall markerboards @ 6' in height, same widths as shown on interior elevations. VE credit combined with ARC.3</p> <p>Additional cost for painting exposed wall surfaces are combined with ARC.3.</p> <p>Update 7/7/17: Jeremy C. provided clarification that sliding markerboards will not change in size. Carl will follow up with Nelson Adams to revise their VE proposal based on this information.</p> <p>Update 7/18/17: Revised pricing received from Nelson Adams. All sliding markerboards remain full height as shown on the drawings, wall markerboards and tackboards will become 6' in height.</p>
	ARC.5	Eliminate acoustical wall panels in upper clerestory areas	<p>JA to revise RCP to delete acoustical wall panels in upper clerestory. JA to incorporate use of acoustical ceiling panels on vertical surfaces.</p> <p>Update 06/23/17: SB directed JA to delete acoustical wall panels in the clerestory walls. TM to confirm \$30K saving</p> <p>Update 7/6/17: Credit provided for deleting these panels in the clerestory wall areas. Additional cost for painting exposed wall surfaces are also provided.</p>
	ARC.6	Eliminate wall tile behind lockers in Rooms 111 & 114.	<p>After discussion with the team it was determined that all tile will be eliminated from the scope of work in the changing rooms. See ARC.18 below</p>
	ARC.7	Lower height of wainscot tile in restrooms to 4' high	<p>RS to provide pricing for proposed revision</p> <p>Update 06/23/17: Pricing for credit received from Silverado Tile.</p>
	ARC.8	Eliminate floor tile in Toilet and changing rooms. Replace with a sealed concrete finish.	<p>See ARC 18 below</p>

VALUE ENGINEERING COST TRACKING LOG

Marshall Classroom Building

Oxnard School District

2900 Thurgood Marshall Dr, Oxnard, CA 93036

July 19, 2017

CCD Required	NO	COST TRACKING DESCRIPTION	NEXT ACTION/STEP/COMMENTS
	ARC.9	Replace entire roof with hot mop- Roofing VE Items	RS to provide pricing for hot mop roof through out the project. Update 06/23/17: TM working with Best Interior to develop a value engineering package that retains the existing design. Update 7/6/17: CM has discussed potential VE items with Best, including use of a lighter gauge standing seam roofing material. Update 7/18/17: Use of a lighter gauge standing seam roofing material is not acceptable to CSDA. Best Contracting looked again at their number and submitted a credit amount.
CCD	ARC.10	Use standard Hydraulic elevators in lieu of MRL elevator	JA to provide revised design for using a jack less hydraulic elevator Update 06/23/17: SB directed team to pursue the hydraulic elevator. TM to forward shop drawing for hydraulic elevator to JA for coordination with designed structure for the shaft and equipment room Update 7/6/17: Republic Elevator has provided drawings for space requirements of the elevator shaft and machine room. CSDA has reviewed and indicates that required space requirements will work within current designed structure.
	ARC.11	Delete energy management system.	RS to obtain credit to delete EMS in it entirety Update 06/23/17: Sheldon provided credit.
	ARC.12	Delete fire department ladders	JA to call fire marshal to understand requirement of exterior fire ladders Update 06/23/17: JA and TM to visit fire department to delete exterior ladders for building and elevator tower Update 7/6/17: Per Jose/CSDA the exterior ladders as shown on G-003 will not be required based on discussion with the local fire department.
CCD	ARC.13	Delete framing at elevator opening smoke doors.	SB accepted deletion. Finalize credit to GMP.
CCD	ARC.14	Delete hand dryers	SB accepted deletion. Finalize credit to GMP JA to revise specifications to include paper towel dispensers Update 06/23/17: Paper towel dispensers shall OFCI.
CCD	ARC.15	Revise Guardrail Detail	JA to review design of handrail detail and revise to simplify and reduce cost. Also see ARC.19 below Update 06/23/17:CA Buchen provided revised design for guardrails which was accepted by SB and JA. Credit provided by CA Buchen.
	ARC.16	Use thinset in lieu of mortar set tile	After discussion with the team it was determined that the mortar bed would be deleted at 1st and 2nd floor restrooms and that the tile would be thinset. Need to add the sloping of floor to drains. RB to provide pricing Update 06/23/17: Credit provided by Silverado.
CCD	ARC.17	Remove 2nd floor canopy over walkways	JA to review the shading study and determine if a portion of the walkway cover can be reduced Update 06/23/17: Still pending structural engineer response. JA to follow on 06/26/17 Update 7/6/17: Jose/CSDA has been working with the structural engineer for drawings/details in order for Bernards to request subcontractor pricing. Update 7/18/17: The structural engineer provided drawings on 7/18/17 for subs to review and provide pricing.
	ARC.18	Delete all tile from change rooms and provide painted walls and resilient tile with rubber base	RS to provide pricing for proposed revisions. Update 06/23/17:Credit provided by Silverado.
	ARC.19	Delete galvanized finish for stairs, guardrails and handrails and provide zinc primer with paint finish	RS to provide pricing for proposed revisions. Update 06/23/17: Steel contractor stated the is no cost difference with zinc coating and galvanizing.

VALUE ENGINEERING COST TRACKING LOG

Marshall Classroom Building

Oxnard School District

2900 Thurgood Marshall Dr, Oxnard, CA 93036

July 19, 2017

CCD Required	NO	COST TRACKING DESCRIPTION	NEXT ACTION/STEP/COMMENTS
	ARC.20	Delete requirement of waterproof wrap around building	JA to review specification to determine what is required and RS to reach out to plaster subcontractors to determine what is included Update 06/23/17: TM got price to wrap the first 5 feet of the building.
	ARC.21	Delete drywall soffit at high ceiling and provide T-Bar and acoustical tile.	JA to prepare sketch of proposed T-Bar soffit for final pricing Update 7/6/17: Jose/CSDA has rejected this potential VE item.
	ARC.22	Revise operable windows to fixed windows	JA to revise specification for windows. TM to price Update 7/6/17: Jose/CSDA has revised the aluminum window spec and pricing has been requested from subcontractor. Update 7/18/17: CSDA revised the aluminum window spec. again and answered subcontractor questions. Subcontractor has provided credit for fixed windows in place of operable.
	ARC.23	Flush Aluminum Windows with Exterior wall	JA to revise specification for windows. TM to price Update 7/6/17: Jose/CSDA has revised the aluminum window spec and pricing has been requested from subcontractor. Update 7/18/17: CSDA revised the aluminum window spec. again and answered subcontractor questions. Subcontractor has provided credit for fixed windows in place of operable. JA to revise detail for window install. TM to price Update 7/6/17: Jose/CSDA has revised the aluminum spec and pricing has been requested from subcontractor. Update 7/18/17: CSDA revised the aluminum window spec. again. Window width is now 4 1/2" but still held to outside with return on inside of wall.
	ARC.24	HVAC VE Items	Meeting with CFW, Bernards and Sheldon Mechanical to discuss potential VE items. Items include deduct for standalone control system vs. DDC control system, deduct to change side discharge rooftop units to down shot, deduct to change ductwork from rectangular to round and added cost to install copper coils on rooftop units. Update 7/7/17: The copper fin added cost has been rejected. The (3) credit items are still under consideration. Jose A. to follow up with mechanical engineer to question why his response to down shot roof top units will not work. Update 7/18/17: Mechanical engineer has rejected the proposed down shot type units due to space limitations. Credits for standalone control system and use of round ducts will be accepted.
	ARC.25	Electrical VE Items	Taft Electric has been contacted regarding potential VE items and have submitted the following; Deduct for alternate light fixture package using a different manufacturer, deduct for use of MC cables for all branch circuits in lieu of flex conduit, deduct for use of aluminum brass in lieu of copper on all switchgear, deduct for use of native soil in lieu of concrete backfill at ductbanks. The Electrical Engineer has reviewed and provided a response, to be reviewed further with CFW & CSDA. Update 7/7/17: After reviewing the electrical VE items it was determined to still pursue the potential cost savings of an alternate lighting package and also request a cost savings number for use of slurry backfill in ductbank trenches. Update 7/18/17: Potential cost savings for the alternate lighting package is acceptable. Taft Electric confirmed no savings for use of slurry backfill in ductbank trenches.

VALUE ENGINEERING COST TRACKING LOG

Marshall Classroom Building

Oxnard School District

2900 Thurgood Marshall Dr, Oxnard, CA 93036

July 19, 2017

CCD Required	NO	COST TRACKING DESCRIPTION	NEXT ACTION/STEP/COMMENTS
	ARC.26	Door Hardware Savings (hinges, etc.)	Scott B. requested a door hardware cost savings for use of butt hinges instead of the specified continuous hinges. Scott will forward a copy of District hardware standards to Carl for discussion with the subcontractor for any potential savings.
	ARC.27	Plumbing VE Savings	Carl M. will contact the low bid plumbing subcontractor to discuss any potential cost saving items.
	SIT.1	Eliminate construction of (5) CIP concrete seat benches, District to provide benches	SB accepted deletion. Finalize credit to GMP Update 7/6/17: Credit for deleted concrete benches requested from subcontractor. Update 7/18/17: Credit proposal received from subcontractor.
	SIT.2	Remove PCC Pavers and concrete sub-slab for pavers, leave existing AC paving.	SB accepted deletion. Finalize credit to GMP Update 7/6/17: Credit for deleted concrete pavers and sub slab requested from subcontractor. Update 7/18/17: Credit proposal received from subcontractor.
CCD	SIT.3	Remove raised planter walls - concrete, rebar, waterproofing and landscaping & irrigation	After discussion it was determined to eliminate all raised planters but retain all landscaping at grade. RS to finalize credit for deletion of raised planters JA to provide revised design for landscaping at grade for pricing Update 7/18/17: Credit proposal received from subcontractors for deleted raised planters. Revised landscape drawings not provided, no change in cost proposed for landscaping at planters.
CCD	SIT.4	Remove concrete mow strip, replace with natural grass	JA to review with DSA the need to 6' mow strip with plan checker Update 06/23/17: JA to submit CCD to delete 6' mow strip Update 7/6/17: Pricing has been requested from subcontractor for revising mow strip from 60" to 12" wide. Update 7/18/17: Credit proposal received from subcontractor.
	SIT.5	Delete gravity wall, use curb	JA to review with Civil if gravity wall can be deleted. This would me budget funds to delete the demolition of the ball walls could be removed. Update 06/23/17: JA to confirm with civil engineer that gravity wall can be deleted. Update 7/7/17: This potential VE item has now been rejected.
	SIT.6	Delete perimeter curb & 4" CAB w/ geo fabric at rubber play surface, install rubber surfacing	Rejected
	SIT.7	Delete site concrete mock-up	SB accepted deletion. Finalize credit to GMP
	SIT.8	Reduce cost reconstruction at new electrical service	JA to have civil engineer provide demo and construction for new electrical service. Update 7/6/17: Site photos of the area for SCE work and approximate electrical underground pathway back to the electrical room have been provided to CSDA for use by Civil Engineer. Update 7/7/17: Carl M. will go back into the GMP and verify if there are still potential costs available. Update 7/18/17: After reviewing costs again with estimators, a cost savings was determined.



VALUE ENGINEERING COST TRACKING LOG

Marshall Classroom Building

Oxnard School District

2900 Thurgood Marshall Dr, Oxnard, CA 93036

July 19, 2017

CCD Required	NO	COST TRACKING DESCRIPTION	NEXT ACTION/STEP/COMMENTS
	SIT.9	Gas Line Revisions	<p>Meeting with Gas Company and Engineer to resolve missing gas design took place on 6/26/17 with the So Cal Gas representative. The rep is currently investigating in house on pipe capacity and meter and will report back to Team. There is the possibility that the meter will need to be upsized, which will be a cost to the School District.</p> <p>Update 7/7/17: Jose A. will request that plumbing engineer contact the Gas Co. rep to receive information in order to make final decision.</p> <p>Update 7/18/17: The Gas Company representative has been contacted by Bernards on numerous occasions for an update with no response. CSDA's plumbing engineer is also awaiting a return call. With no clear response to date from Gas Co. this potential VE credit will be rejected. The 50K allowance will continue to be carried in the GMP.</p>

Bid Evaluation Report

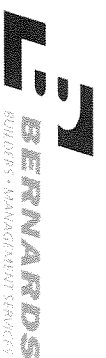

Erosion Control

Marshall Classroom Building

Subcontractors

Job Number **1641**
 Bid Date **6/7/2017**
 Date Printed **7/27/2017**

Description	Whitson CM / Bernards	Social Stormwater Runoff Solution			
Base Bid	See below	See below			
Spec # : 312500	Included	Included			
Bond Rate (if required)					
Furnished, Installed, FOB Jobsite, Tax Included	Included	Included			
Plans and Specs Dated: 1/28/2016 & 10/4/2016	Included	Included			
Acknowledgment of RFIs 1-75 dated 6.5.17	Included	Included			
Bid Good for 60 Days	Included	Included			
Prevailing Wage	N/A	N/A			
Prequalified per Oxnard School District Standards	N/A	N/A			
Attachment C Acknowledgement	N/A	N/A			
Storm Water Compliance	1,200	520			
"Due to the project being under 1 acre this project is not subject to the State CGP"	Included	Included			
Provide project related Water Pollution Control Program (WPCP) by Qualified developer	Included	Included			
Development of project specific Best Management Practices (BMP's)	Included	Included			
Development of erosion control plan for inclusion in WPCP	Included	Included			
SWPPP (QSP/QSD) Services					
Qualified SWPPP Practitioner QSP conduct weekly site inspections, photos, document, etc	18,720	10,400			
Rate per week for monitoring	\$360/wk	\$200/visit			
Keep records & documents updated	Included	Included			
Provide recommendations for reqs of BMP upkeep & maintenance (but won't do the work)	Included	Included			
Electronically file all data for Permit documents as required	Included	Included			
Pre/During/Post Rain-Event Visual Inspections	4,320	2,640			
Rate per week/visit for monitoring the rain monitoring	\$360/wk	\$220/visit			
Erosion Control - No Plans Provided					
Silt Fencing at perimeter of sites	21,402	21,402			
Fiber Rolls at perimeter of existing parking lot rework - A-102	Included	Included			
Fiber Rolls at new school addition perimeter - G-003	Included	Included			
Fiber Rolls at new playground area perimeter - G-003	Included	Included			
Construction Entrances	Included	Included			

Bid Evaluation Report

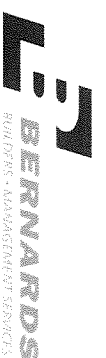

Erosion Control

Marshall Classroom Building

Subcontractors

Job Number: 1641
 Bid Date: 6/7/2017
 Date Printed: 7/27/2017

Description	Whitson CM / Bernards	Social Stormwater Runoff Solution	Subcontractors			
			Amount			
Storm Drain Inlet Protection	Included	Included				
SWPPP & BMP Implementation	Included	Included				
SWPPP & BMP Implementation - Removal at completion of project	Included	Included				
QSP Monitoring	See below	See below				
Laydown/Trailer Area Erosion Control:	20,985	20,985				
Fiber Rolls at perimeter of existing grass field for trailer/parking/laydown/storage use during construction	Included	Included				
Geofabric over the grass, rock surface	Included	Included				
Removal of above at project completion	Included	Included				
Temporary Construction Fencing & Gates - Bernards	22,730	22,730				
Temp Fencing at existing parking lot rework, 1-side use existing fencing along the creek - A-102, install, maintain, removal	Included	Included				
Temp Fencing at new school addition perimeter - G-003	Included	Included				
Temp Fencing at new playground area perimeter - G-003	Included	Included				
Gates	Included	Included				
TOTALS	89,357	78,677	0	0	0	0
Recommendation:			Amount			
Social Stormwater Runoff Solution			78,677			

Bid Evaluation Report

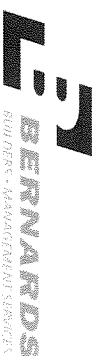

Surveying

Marshall Classroom Building

Subcontractors

Description	Adkan Engineers	Brenner & Carpenter	Hunsaker & Associates	MNS Engineers	Job Number	1641
					Date Printed	7/27/2017
					Bid Date	6/7/2017
					Michael Baker International	Stantec
Base Bid	22,000	25,000	60,400	17,055	8,900	39,950
Spec # : 00700 - General Conditions	Included	Included	Included	Included	Included	Included
Bond Rate (if required)	N/A	N/A	N/A	N/A	N/A	N/A
Furnished, Installed, FOB Jobsite, Tax Included	Included	Included	Included	Included	Included	Included
Plans and Specs Dated: 1/28/2016 & 10/4/2016	Included	Included	Included	Included	Included	Included
Acknowledgment of RFIs 1-75 dated 6.5.17	Included	Included	Included	Included	Included	Included
Bid Good for 60 Days	Included	Included	Included	Included	Included	Included
Prevailing Wage	Included	Included	Included	Included	Included	Included
Prequalified per Oxnard School District Standards	N/A	N/A	N/A	N/A	N/A	N/A
Attachment C Acknowledgement	N/A	N/A	N/A	N/A	N/A	N/A
Set-up	Included	Included	Included	Included	Included	Included
Travel Costs	Included	Included	Included	Included	Included	Included
Horizontal Control	Included	Included	Included	Included	Included	Included
Survey Boundary Map	Included	Included	Included	Included	Included	Included
Excavation	Included	Included	Included	Included	Included	Included
Rough Grade Staking	Included	Included	Included	Included	Included	Included
Blueprint Stakes at Bottom of Excavation for Fine Grading	Included	Included	Included	Included	Included	Included
Gridlines at Elevator & Exterior Stairs	Included	Included	Included	Included	Included	Included
Buildings	Included	Included	Included	Included	Included	Included
Building Corner Stakes (All Bids)	Included	Included	Included	Included	Included	Included
Utility Sleeve Layout for Sanitary Sewer, Storm Drain, Domestic and Fire Water, Natural Gas and Permanent Electrical Service	Included	Included	Included	Included	Included	Included
Final Verification Upon Project Completion	Included	Included	Included	Included	Included	Included
Site	Included	Included	Included	Included	Included	Included
Stakes for Sanitary Sewer, Storm Drain, Natural Gas and Domestic Fire & Domestic Water	Included	Included	Included	Included	Included	Included
Line and Grade Stakes for Underground Electrical Devices, POCs and Duct Banks	Included	Included	Included	Included	Included	Included
Line Stakes for demo/saw cut of asphalt at existing northeast parking lot. Provide markings for new parking stalls.	Included	Included	Included	Included	Included	Included
Line and grade stakes for rubberized playground area	Included	Included	Included	Included	Included	Included
1-person survey crew rate per hour	\$185/hr		\$192/hr	\$180/hr	Included	Included
2-person survey crew rate per hour	\$260/hr		\$234/hr	\$260/hr		
	5,000	2,000		6,667	12,000	
TOTALS	27,000	27,000	60,400	23,722	20,900	39,950
Recommendation:	Amount					
Michael Baker International	20,900					

Bid Evaluation Report



Reinforcing Steel

Marshall Classroom Building

Subcontractors

Job Number **1641**
 Bid Date **6/7/2017**
 Date Printed **7/27/2017**

Description	Upland Contracting		Vista Steel		Subcontractors		Job Number	Bid Date	Date Printed	
Base Bid										
Spec # : 032000	85,814	Included	83,445	Included						
Bond Rate (if required)										
Furnished, Installed, FOB Jobsite, Tax Included										
Plans and Specs Dated: 1/28/2016 & 10/4/2016										
Acknowledgment of RFIs 1-75 dated 6.5.17										
Bid Good for 60 Days										
Prevailing Wage										
Pregualified per Oxnard School District Standards										
Attachment C Acknowledgement										
Rebar										
New Classroom Addition Building per Structural, Architectural & Civil sheets										
Rebar for Footings										
Rebar for Spread Footings										
Rebar for Column Footings										
Rebar for Stair Footings										
Rebar for Pad Footings										
Rebar for Elevator Pit										
Rebar for Slab on Grade										
Hoisting as Required										
Note 15 - Planter Wall per Architectural & Structural drawings - 2 shown near stairs are NOT on S sheets, 36'x8', build them sim to right side of det 6/S-401	5,000		5,000							
Site Concrete Reinforcing	24,486		12,025							
Paving, curbs, seat walls, planter walls										
Site curbs FOB jobsite										
SIT.3										
TOTALS	111,800		96,970		0	0	0	0	0	
Recommendation:										
Vista Steel	Amount		96,970							

Bid Evaluation Report



Building Concrete

Marshall Classroom Building

Subcontractors

Description	Barcelo Construction		Santa Clarita Concrete		Job Number	Bid Date	Date Printed
	386,879	Included	395,600	Included			
Base Bid					1641	6/7/2017	7/27/2017
Spec #: 03 1000 - Concrete Forming Accessories	Included		Included				
Spec #: 03 2000 - Concrete Reinforcing	Included		Included				
Spec #: 03 3000 - Cast-In-Place Concrete	Included		Included				
Bond Rate (if required)			Bond @ 1%				
Furnished, Installed, FOB Jobsite, Tax Included	Included		Included				
Plans and Specs Dated: 1/28/2016 & 10/4/2016	Included		Included				
Acknowledgment of RFIs 1-75 dated 6.5.17	Included		Included				
Bid Good for 60 Days	90 Days		30 Days				
Prevailing Wage	Included		Included				
Prequalified per Oxnard School District Standards	N/A		N/A				
Attachment C Acknowledgement	N/A		N/A				
Structural Concrete	Included		Included				
Typical SOG Underlayment Detail 14/S-400A:	Included		Included				
4" layer crushed rocks Subbase over prepared subgrade	Included		Included				
Base - 2" Sand Fill over crushed rock	Included		Included				
15 mil. Vapor Barrier by Stego Ind. Over sand	Included		Included				
5" SOG	Included		Included				
Reinforcing steel furnish & install, included w/ CIP concrete bid	Excluded		Excluded				
Reinforcing steel furnish & install, separate Rebar Bid	w/ Rebar		w/ Rebar				
Install Anchor/Sill Bolts for Wood Framing per Wall Framing Details - S-401	Included		Included				
Spread Footings per Schedule on Foundation Pages S-401,402,403 (WF-1, WF-2 & F3)	Included		Included				
24" X 18" Conc Footing at Stairs per 1/S-700B	Included		Included				
Tie Rod Brace detail and concrete blockout at Baseplates - 3/S-700B	Included		Included				
1-6" thk Mat slab at Elevator Pit per 12/S-700A	Included		Included				
Elevator Pit wall 10" thk per 12/S-700B	Included		Included				
Site Control Plan C-201							
Note 15 - Planter Wall per Architectural & Structural drawings - 2 shown on S-211 & 6/S401, are part of the building construction	30,000		Included				
Note 15 - Planter Wall per Architectural & Structural drawings - 2 shown near stairs are NOT on S sheets, 36'x8'	30,000		26,600				
Install Guiderail baseplates per 16/S-700B	Included		Included				
Lt Wt Concrete Fill at Balconies & Classrooms on 2nd Floor per Note 7A & 7B/S212 - 1-1/2" twt concrete topping	Included		Included				

Bid Evaluation Report

Building Concrete

Marshall Classroom Building

Subcontractors

Description	Barcelo Construction		Santa Clarita Concrete		Job Number	Bid Date	Date Printed
	Barcelo Construction	Santa Clarita Concrete	Santa Clarita Concrete	Barcelo Construction			
SCC: Deck to be poured prior to construction of walls, otherwise add for another pump system & hoseman to place concrete	Included	6,500			1641	6/7/2017	7/27/2017
Concrete Fill at Pan Filled Metal Stair Treads and Landings w/ W4x4 Reinforcing - 2&6/S-700B	Included	Included					
Balco Stair Strips per keynote 05.03 sheet A-420 & detail 11/A-560	2,500	2,500					
2" contrasting strip, abrasive strip	Included	Included					
6" Upturned CIP concrete base w/ toolod radius at lockers - 14 & 15/A-530	Included	Included					
Depressed slabs at restrooms for ceramic tile work, not shown properly	Included	Included					
Trench Drain concrete basin per 4/S-400A	w/ Site Utilities	w/ Site Utilities					
Other Items:	Included	Included					
All Reinforcing Steel for your work	w/ Rebar	w/ Rebar					
Dewatering as Required	Included	Included					
Setting Anchor Bolt Templates	Included	Included					
Safety walk and progressive cleanup	4,640	4,640					
Curing and Sealing Compounds per Specs as Required	Included	Included					
Drypacking baseplates	1,000	Included					
Base plates for Round HSS and Square HSS per 18/S-401	Included	Included					
Clean up to debris bins	5,100	5,100					
Wash Out Bins	2,500	2,500					
Depressed floors at 1st floor RR's (include, they aren't shown) for ceramic tile install	5,000	5,000					
Spoils removal	approx 325cy	approx 325cy					
SIT.3	(8,700)	(8,709)					
SIT.3	(30,000)	(26,600)					
TOTALS	428,919	413,131	0	0	0	0	0
Recommendation:	Amount	Amount					
Santa Clarita Concrete	413,131						

Bid Evaluation Report



Structural Steel

Marshall Classroom Building

Subcontractors

Description	C.A. Buchen	Rincon Ironworks	Metal Supply, Inc.	ACSS	Job Number	1641
					Bid Date	6/7/2017
					Date Printed	7/27/2017
Base Bid	See below	See below	See below	No Bid		
Spec #: 05 1200 - Structural Steel Framing	Included	Included	Included			
Spec #: 05 5000 - Metal Fabrications	Included	Included	Included			
Bond Rate (if required)						
Furnished, Installed, FOB Jobsite, Tax Included	Included	Included	Included			
Plans and Specs Dated: 1/28/2016 & 10/4/2016	Included	Included	Included			
Acknowledgment of RFIs 1-75 dated 6.5.17	Included	Included	Included			
Bid Good for 60 Days	14 Days	Included	Included			
Prevailing Wage	Included	Included	Included			
Prequalified per Oxnard School District Standards	N/A	N/A	N/A			
Attachment C Acknowledgement	N/A	N/A	N/A			
Structural Steel						
New Classroom Building	165,450	234,955	304,688			
HSS Steel Columns, C1, C2, C3, C4 & C5 on First & Second Levels -5" round, 5x5 7x5, 10x8, & 7x7	Included	Included	Included			
HSS Beams at 1st & 2nd floors per floor plans	Included	Included	Included			
HSS Beams at Elevator - 3 each HSS 12x4 tubes per sketch in RFI #3	Included	Included	Included			
Include added 3rd steel column	7,500	7,500	7,500			
HSS Columns & beams at wall elevation S-600E & 19&20/S-600F	Included	Included	Included			
HSS columns in stud walls to have welded studs - 13/S-700	Included	Included	Included			
Base plates for Round HSS and Square HSS per 18/S-401	Included	Included	Included			
"C" Channel Framing at Elevator - S111	Included	Included	Included			
"W" Steel Beams at Elevator - 1/S-700A & 17/S-700A	Included	Included	Included			
Beam to Beam Connection Schedule & details 1/S-700A	Included	Included	Included			
Double angle braces & gusset plate at HSS column at roof transitions 17/S-600D	Included	Included	Included			
1/2" thk x 5" w plate at roof transitions 17/S-600D & 20/S-600E	Included	Included	Included			
Safety Cable Railing as Required - Install, maintain, removal & return to steel sub	3,250	3,250	3,250			
FOB Anchor Bolts/ Templates for Own Work	Included	Included	Included			
FOB Embeds, Weld Plates, etc. for Own Work	Included	Included	Included			
Safety walk and progressive cleanup	3,093	3,093	3,093			
Hoisting for All Work	Included	Included	Included			
Steel Stairs						
Galvanized	122,090	Included	Included			

Bid Evaluation Report

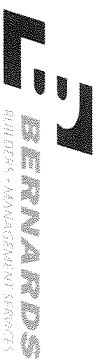

Structural Steel

Marshall Classroom Building

Subcontractors

Description	C.A. Buchen	Rincon Ironworks	Metal Supply, Inc.	ACSS	Job Number	1641
					Bid Date	6/7/2017
					Date Printed	7/27/2017
Stairs 1 & 2 at New Classroom Bldg - S-211,212 & S-700B	Included	Included	Included			
Steel Stairs (Pan Filled Concrete) - A-420	Included	Included	Included			
HSS, MC, C Stringers, L Brackets and Metal Pan Landings	Included	Included	Included			
Conc Nosing at Stairs - included w/ the stairs?	1,250	Included	Included			
Stair Railings and Stair Guardrails	Included	Included	Included			
1-1/2" Handrail Both Sides	Included	Included	Included			
Guardrail at Midlandings	Included	Included	Included			
Guardrail at Top of Stairs	Included	Included	Included			
Stair 1 - 12/S700B	Included	Included	Included			
Stair 2 - 11/S700B	Included	Included	Included			
Railings & Guardrails	Included	132,560	Included	100,000		
2nd Floor New Classroom Bldg - S-212 & 8/S-6001/S-600D	Included	Included	Included			
Deck guardrail detail - HSS2-1/2x2-1/2x3/16 at 4'oc	Included	Included	Included			
Arch drawing sheet A-112, note 5.33, see 15/A-560	Included	Included	Included			
Steel posts & plate top rails, w/ baseplates 8/S-600	Included	Included	Included			
Railing to have a Prefab panel per 10/A-560	Orsogrill	Included	Included			
Prefab Panel Elevation detail - 7/A-560	Included	Included	Included			
Railing Inserts per detail 2.3/A-560 - shows 2x1 rect mesh 11 ga galv panel	Included	Included	Included			
Railing Inserts per Spec is diamond mesh	Excluded	Excluded	Excluded			
Misc. Metal	Included	Included	Included			
Steel plate continuous across hoistway ground fl - 5/A-561	2,500	Included	2,500			
Steel plate continuous across hoistway 2nd fl- 7/A-561	2,500	Included	2,500			
Pit ladder 13/A-561, notes states by Elev Mfr, but needs to be w Steel	Included	3,000	Included			
HSS at Canopy connections - 19,20/S-600F	Included	Included	Included			
Elevator Sill Angle & Threshold	Included	Included	Included			
Roof Access Ladders in Electrical rm 206 - A-112, 10/A-500	Included	Included	Included			
Steel ladder mounted to wall mtg all OSHA requirements	Included	Included	Included			
Site	Included	Included	Included			
Steel Bollards at New Electrical Transformer, FOB jobsite, 1/E-102	500	4,000	4,000			
Steel Bollards at New DDCV Assembly, FOB jobsite, C-401 (not shown, include 8 each)	500	4,000	4,000			

Bid Evaluation Report

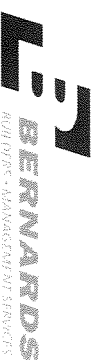

Structural Steel

Marshall Classroom Building

Subcontractors

Description	C.A. Buchen	Rincon Ironworks	Metal Supply, Inc.	ACSS	Job Number	1641
					Bid Date	6/7/2017
					Date Printed	7/27/2017
Fire Department Access Ladder, shown on FLS/Site Plan near grid D&2 SW side - G-003, galvanized	7,500	6,500	7,500			
Fire Department Access Ladder, shown on FLS/Site Plan near grid K&11 near elevator - G-003, galvanized	7,500	6,500	7,500			
ARC.12	(15,000)	(13,000)	(15,000)			
ARC.15	(14,500)	(14,000)	(14,000)			
TOTALS	294,133	378,358	417,531	0	0	0
Recommendation:	Amount					
C.A. Buchen	294,133					



Bid Evaluation Report

Rough Carpentry

Marshall Classroom Building

Subcontractors

Job Number	1641
Bid Date	6/7/2017
Date Printed	7/27/2017

Description	Subcontractors			
	Abdellatif Enterprises	Core Contracting	JF Construction	WS Klem
Base Bid	1,244,000	997,037	922,861	1,156,000
Spec #: 06 1000 - Rough Carpentry	Included	Included	Included	Included
Spec #: 06 1733 - Wood I-Joists	Included	Included	Included	Included
Spec #: 06 1813 - Glue Laminated Beams	Included	Included	Included	Included
Bond Rate (if required)	Bond at 2%	Bond at 2%	Bond at 2%	Bond at 2%
Furnished, Installed, FOB Jobsite, Tax Included	Included	Included	Included	Included
Plans and Specs Dated: 1/28/2016 & 10/4/2016	Included	Included	Included	Included
Acknowledgment of RFIs 1-75 dated 6.5.17	Included	Included	Included	30 days
Bid Good for 60 Days	Included	Included	Included	Included
Prevailing Wage	N/A	N/A	N/A	N/A
Prequalified per Oxnard School District Standards	N/A	N/A	N/A	N/A
Attachment C Acknowledgement	N/A	N/A	N/A	N/A
Rough Framing				
Wall Types Sheet - A-620	Included	Included	Included	Included
Plywood Shear Wall Schedule - S-600	Included	Included	Included	Included
Plywood Sheathing as Shown on Wall Types	Included	Included	Included	Included
Prefabricated plywood web joists "I" Joists per spec section	Included	Included	Included	Included
Open Web Trusses, I-Joists, LVL per Schedule 4/S-600F	Included	Included	Included	Included
MFR - TrusJoist, Red Built or equal	Included	Included	Included	Included
Glue-Laminated Beams & Struc Eng. Beams per spec section	Included	Included	Included	Included
Simpson HDW as Scheduled	Included	Included	Included	Included
Supply Anchor/Sill Bolts for Wood Framing per Wall Framing Details	7,551	7,551	7,551	7,551
Hold Down Schedule 20/S-600	Included	Included	Included	Included
Anchor Rod Schedule - 17/S-401	Included	Included	Included	Included
Mechanical Platforms at Roof 3&5B/S-700B	Included	Included	Included	Included
Wall Framing - 2x4, 2x6, 2x8	Included	Included	Included	Included
Wood Backing for All Wall Items - Millwork, TV's, Marker/Tackboards, Handrails, M.E.P.	Included	Included	Included	Included
Plywood Backboards - Electrical / Low Voltage	3,200	3,200	3,200	3,200
Wood Nailers at Roof Parapet Coping - 2/A-500	Included	Included	Included	Included
Safety Railing as Required at 2nd Floor	5,000	5,000	5,000	5,000
Plywood Floor Sheathing - 19/S-600C	Included	Included	Included	Included
Plywood Roof Sheathing - 19/S600C	Included	Included	Included	Included
1/2" Plywood at Exterior Walls per Struc Walls and Ext. Walls as shown on S-600	Included	Included	Included	Included
Flooring & Roof Joists per Schedule on Framing Plans	Included	Included	Included	Included
1/2" Plywood at Plaster Pilasters	Included	Included	Included	Included

Bid Evaluation Report



Rough Carpentry

Marshall Classroom Building

Subcontractors

Description	Subcontractors				Job Number	Bid Date	Date Printed
	Abdellatif Enterprises	Core Contracting	JF Construction	WS Klem			
Exterior Plywood at Underside of Roof Overhang per 9/A-501	Included	Included	Included	Included	1641	6/7/2017	7/27/2017
Install Pipe Columns per details 2,5,6/5-600D - coordinate w/ Steel sub	Included	Included	Included	Included			
Roof Joists per Schedule on Framing Plans	Included	Included	Included	Included			
Roof Crickets per A-131 - should be w/ roofing, use tapered Insul	Excluded	Excluded	Excluded	Excluded			
Safety walk and progressive cleanup	9,280	9,280	9,280	9,280			
Framing for all recessed items FEC's, etc.	Included	Included	Included	Included			
Blocking & backing for ceilings & duct supports, unknown locations	6,400	6,400	6,400	6,400			
Blocking & backing for roof ladders	600	600	600	600			
Depressed floors at 2nd floor RR's (include, they aren't shown) for ceramic tile install	5,000	5,000	5,000	5,000			
Framing for doors heads & jambs at elevator smoke containment door assembly	4,000	4,000	4,000	4,000			
Fire Treated Lumber	Included	Included	Included	Included			
Storage of Lumber and Delivery to Site	Included	Included	Included	Included			
Hoisting for your work	Included	Included	Included	Included			
All Required Caulking and Sealants for your work	Included	Included	Included	Included			
Scaffolding for Own Work	Included	Included	Included	Included			
Clean-up into your dumpsters	17,000	17,000	17,000	17,000			
Temporary Stairs & ramps	3,000	3,000	3,000	3,000			
Small tools & equipment	3,500	3,500	3,500	3,500			
Security guard	40,200	40,200	40,200	40,200			
Site Security/Alarm/Camera systems	15,477	15,477	15,477	15,477			
ARC.1	9,500	9,500	9,417	9,500			
ARC.13	(4,000)	(4,000)	(4,000)	(4,000)			
ARC.17	(30,000)	(30,000)	(30,521)	(30,000)			
Budget for Lumber Cost Increase	65,000	50,000	50,000	50,000			
TOTALS	1,404,708	1,142,745	1,067,965	1,301,708	0	0	
Recommendation:	Amount						
JF Construction	1,067,965						



Bid Evaluation Report

Cabinets / Millwork

Marshall Classroom Building

Subcontractors

Description	Subcontractors				Job Number	1641
	Bristol Omega	ICI Millwork	K & Z Cabinet	Dennis Reeves Inc.		
Base Bid	47,900	36,107	42,290	34,161	35,270	
Spec # : 06 4000 - Architectural Woodwork	Included	Included	Included	Included	Included	
Spec # : 12 3553 - Manufactured Plastic-Laminate-Faced Casework	Included	Included	Included	Included	Included	
Bond Rate (if required)				Bond at 2.5%		
Furnished, Installed, FOB Jobsite, Tax Included	Included	Included	Included	Included	Included	
Plans and Specs Dated: 1/28/2016 & 10/4/2016	Included	Included	Included	Included	Included	
Acknowledgment of RFIs 1-75 dated 6.5.17	90 days	90 days	60 days	60 days	45 days	
Bid Good for 60 Days	Included	Included	Included	Included	Included	
Prevailing Wage	N/A	N/A	N/A	N/A	N/A	
Prequalified per Oxnard School District Standards Attachment C Acknowledgement	N/A	N/A	N/A	N/A	N/A	
Millwork	Included	Included	Included	Included	Included	
Lower Cabinets with Hardware	Included	Included	Included	Included	Included	
Upper Cabinets with Hardware & Locks on all doors per RFI #	Included	Included	Included	Included	Included	
Plastic Laminate Finish	Included	Included	Included	Included	Included	
Plastic Laminate Countertops	Included	Included	Included	Included	Included	
Plastic Laminate Backsplash	Included	Included	Included	Included	Included	
Enlarged Floor Plans - A-410	Included	Included	Included	Included	Included	
Casework details per A-570	Included	Included	Included	Included	Included	
Include the back panel fastening per 2/A-570	Included	Included	Included	Included	Included	
Include the Cont 2-1/2"x2-1/2" x 16 ga bent sheet metal angle anchorage - 6/A-570	Included	Included	Included	Included	Included	
Typical Classroom per 1/A-410	Included	Included	Included	Included	Included	
Casework & Counters	Included	Included	Included	Included	Included	
Rms - 101, 102, 103, 104	Included	Included	Included	Included	Included	
Rms - 201, 202, 203, 204, 207	Included	Included	Included	Included	Included	
Typical Science Classroom per 2/A-410	Included	Included	Included	Included	Included	
Casework & Counters	Included	Included	Included	Included	Included	
Rms - 107, 109	Included	Included	Included	Included	Included	
Performing Arts Lab per 3/A-410	Included	Included	Included	Included	Included	
Casework & Counters	Included	Included	Included	Included	Included	
Rms - 208	Included	Included	Included	Included	Included	
Locker Room Benches	Included	w/ Lockers	w/ Lockers	w/ Lockers	w/ Lockers	
FRP Panels	Excluded	Excluded	Excluded	Excluded	Excluded	
TOTALS	47,900	36,107	42,290	34,161	35,270	
Recommendation:	Amount					
Dennis Reeves Inc.	34,161					

Bid Evaluation Report



Waterproofing

Marshall Classroom Building

Subcontractors

Description	Systems WP	Proulx	Santa Barbara Surfacing	Letner	Job Number	1641
					Patriot Contracting	Paul Wolff
					Bid Date	6/7/2017
					Date Printed	7/27/2017
Base Bid	See below	See below	See below	See below	83,560	Incomplete
Spec #: 07 1326 - Self Adhering Sheet Waterproofing	Included	Included	Included	Included	Included	Included
Spec #: 07 8400 - Fire Stop and Smoke Seals	w/ Insulation	w/ Insulation	w/ Insulation	w/ Insulation	w/ Insulation	w/ Insulation
Spec #: 07 9200 - Joint Sealants	Included	Included	Included	Included	Included	Included
Bond Rate (if required)	Included	Included	Bond @ 1.8%	Bond @ 1.5%	Bond @ 1%	Included
Furnished, Installed, FOB Jobsite, Tax Included	Included	Included	Included	Included	Included	Included
Plans and Specs Dated: 1/28/2016 & 10/4/2016	Included	Included	Included	Included	Included	Included
Acknowledgment of RFI's 1-75 dated 6.5.17	Included	Included	Included	Included	Included	Included
Bid Good for 60 Days	Included	90 days	90 days	60 days	60 days	Included
Prevailing Wage	Included	Included	Included	Included	Included	Included
Prequalified per Oxnard School District Standards	N/A	N/A	N/A	N/A	N/A	N/A
Attachment C Acknowledgement	N/A	N/A	N/A	N/A	N/A	N/A
Waterproofing						
Waterproofing at elevator pit 12/A-561	4,100	2,300	8,300	3,510	Included	No Bid
Sheet Waterproofing behind Pit walls	Included	Included	Included	Bituthene 4000	Included	-----
1" drainage board & sheet waterproofing at walls	Included	Included	Included	Included 230 sf	Included	-----
Waterproofing under elev pit SOG (no specs) use bentonite, Grace PrePrufe300R or equal	Included	Included	Included	Included	Included	-----
Elastomeric waterproofing on top of pit slab (no spec) - use crystalline product	1,500	2,500	5,400	2,500	Included	-----
Waterproofing at elevator pit penetrations 8/A-561	Included	Included	Included	Included	Included	-----
Waterproofing of foundation wall at planter areas against the bldg C-300	14,030	18,240	Included	15,000	Included	-----
Waterproofing inside exterior Planters - total of 4 planters 6/S-401	Included	Included 1,920 sf	Included	Included	Included	-----
Waterproofing under topping slabs at 2nd floor decks - 6&7/A-510	18,000	20,000	22,600	20,000	Included	-----
Use 07 1326, self adhering waterproofing OR	Included	Included	Included	Included	Included	-----
Use 60-90mil liquid applied waterproofing w/ 1/8" asphaltic board or drainage mat protection course	Included	Included	Included	Included	Included	-----
Safety walk and progressive cleanup	3,480	3,480	3,480	3,480	3,480	-----
Traffic Coatings						
Per Pre-Bid RFI#4	20,560	22,330	27,050	29,860	Included	No Bid
Installed over 2nd floor exterior deck - 6 & 7/A-510	Included	Included	Included	Included	Included	-----
Installed over exterior stairs and landings - not shown	Excluded	Excluded	Excluded	Excluded	Excluded	-----
Product to be Poly-I-Gard 246SF by Polycoat Products OR	Included	Included 2,552 sf	Included	Excluded	Included	-----

Bid Evaluation Report



Waterproofing

Marshall Classroom Building

Subcontractors

Description	Systems WP				Proulx				Santa Barbara Surfacing				Lethner				Patriot Contracting		Paul Wolff			
	Included	Excluded	Included	Excluded	Included	Excluded	Included	Excluded	Included	Excluded	Included	Excluded	Included	Excluded	Included	Excluded	Included	Excluded				
Product to be Gaco Western, GW-15-U62		2,680		2,680		2,680		2,680		2,680		2,680		2,680		2,680		2,680		1,750		
Interior Concrete Sealed Floors																						
Interior concrete floors shown on Finish Sch A-612 marked F1	Included		Included		Included		Included		Included		Included		Included		Included		Included		Included		Included 676 sf	
No Spec Provided OR see 03300,2.1,G	Included		Included		Included		Included		Included		Included		Included		Included		Included		Included		Augaseal W-20	
Caulking & Sealants																					No Bid	
Per Schedule in Specs	Included		Included		Included		Included		Included		Included		Included		Included		Included		Included		-----	
Windows, Doors, Walls, As Shown	Included		Included		Included		Included		Included		Included		Included		Included		Included		Included		-----	
SIT.3		(10,530)		(10,500)		(10,500)		(10,500)		(10,500)		(10,500)		(10,500)		(10,500)		(10,500)		(10,500)		-----
TOTALS		63,636		70,846		69,996		76,346		89,036		0										
Recommendation:	Amount																					
Systems WP	63,636																					



Bid Evaluation Report

Insulation

Marshall Classroom Building

Subcontractors

Description	Subcontractors				Roberts Firestop
	DJ Insulation	Viking Insulation	Alcal	TruTeam/Masco	
Base Bid	26,800	36,892	30,527	26,895	See below
Spec #: 07 2100 - Thermal Insulation	Included	Included	Included	Included	N/A
Spec #: 07 8400 - Fire Stop and Smoke Seals	No Bid	No Bid	No Bid	No Bid	Included
Bond Rate (if required)					
Furnished, Installed, FOB Jobsite, Tax Included	Included	Included	Included	Included	Included
Plans and Specs Dated: 1/28/2016 & 10/4/2016	Included	Included	Included	Included	Included
Acknowledgment of RFIs 1-75 dated 6.5.17	Included	Included	Included	Included	Included
Bid Good for 60 Days	60 Days	Included	30 days	60 days	Included
Prevailing Wage	Included	Included	Included	Included	Included
Prequalified per Oxnard School District Standards	N/A	N/A	N/A	N/A	N/A
Attachment C Acknowledgement	N/A	N/A	N/A	N/A	N/A
Thermal and Blanket Insulation					
Interior, Exterior Walls, Ceilings, Roof	Included	Included	Included	Included	No Bid
R19 & 8" Batts at Int & Ext Walls	Included	Included	Included	Included	-----
R30 at Roof (Not shown)	See below	See below	See below	See below	-----
Walls to Receive Insulation per Wall Types A-620	Included	Included	Included	Included	-----
Wall type A - min 3" sound insulation	Included	Included	Included	Included	-----
Wall type B - double stud walls min 3" sound insulation	Included	Included	Included	Included	-----
Wall type C - min 3" sound insulation	Included	Included	Included	Included	-----
Wall type D - min 3" sound insulation	Included	Included	Included	Included	-----
Wall type E1 - min 3-1/2" foil-faced glass fiber batts	????	Included	Included	Included	-----
Wall type F - Batt insulation	Included	Included	Included	Included	-----
Wall type G - Batt insulation	Included	Included	Included	Included	-----
Wall type H - min 3" sound insulation	Included	Included	Included	Included	-----
Wall type I - min 3" sound insulation	Included	Included	Included	Included	-----
Wall type K - double stud walls Int. Acoustic wall - fiberglass batt insulation	Included	Included	Included	Included	-----
Wall type N - none shown	-----	-----	-----	-----	-----
Wall type O - batt insulation	Included	Included	Included	Included	-----
Rigid Insulation at PVC roofing	w/ Roofing	Included	Included	Included	-----
Rigid Insulation at Standing Seam roofing	Excluded	Included	Included	Included	-----
R-30 insulation at underside of standing seam roofing	7,500	Included	Included	4,965	-----
Fire Stops and Smoke Seals					
Mineral fiber insulation fire safing, damming material, clips and closures	17,324	17,324	17,324	17,324	17,324
Seal openings in floors, fire rated walls & penetrations	Included	Included	Included	Included	Included
At pipes, ducts, conduits & other items shown	Included	Included	Included	Included	Included

Bid Evaluation Report

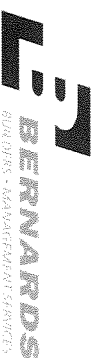

Insulation

Marshall Classroom Building

Subcontractors

Description	DJ Insulation	Viking Insulation	Alcal	TruTeam/Masco	Roberts Firestop	Job Number	1641	
						Bid Date	6/7/2017	
						Date Printed	7/27/2017	
MFR - Bio Fireshield, 3M, GE or Nelson	Included	Included	Included	Included	Included			
Sealants, firestop putty, mortar, pillows, mineral fiber saifing	Included	Included	Included	Included	Included			
TOTALS	51,624	54,216	47,851	49,184	0		0	
Recommendation:	Amount							
Alcal	47,851							

Bid Evaluation Report

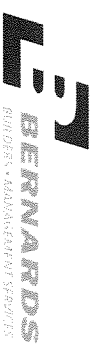

Sheet Metal & Metal Panels

Marshall Classroom Building

Description	R&J SM	Letter	Commercial Roofing	Merit Metal Products	Job Number	
					Patriot Contracting	Valencia Sheet Metal
					Date Printed	7/27/2017
					Bid Date	6/7/2017
Base Bid	See below	167,950	See below	See below	189,170	103,880
Spec #: 07 4000 - Metal Roof Panels	Included	Included	Included	Included	Included	Included
Spec #: 07 6000 - Flashing Sheet Metal	Included	Included	Included	Included	Included	Included
Bond Rate (if required)	Bond @ 2.5%	Bond @ 1.5%	Bond @ 1%	Bond @ 1%	Bond @ 1%	Bond @ 2%
Furnished, Installed, FOB Jobsite, Tax Included	Included	Included	Included	Included	Included	Included
Plans and Specs Dated: 1/28/2016 & 10/4/2016	Included	Included	Included	Included	Included	Included
Acknowledgment of RFI's 1-75 dated 6.5.17	Included	Included	Included	Included	Included	Included
Bid Good for 60 Days	30 Days	90 days	60 days	60 days	60 days	30 days
Prevailing Wage	Included	Included	Included	Included	Included	Included
Prequalified per Oxnard School District Standards	N/A	N/A	N/A	N/A	N/A	N/A
Attachment C Acknowledgement	N/A	N/A	N/A	N/A	N/A	N/A
Sheet Metal	56,198	Included	No Bid	8,600	Included	Included
Exterior Elevations A-210, A-211; Building Sections A-310, 311, 320, 321, 322	Included	Included	-----	40,000	Included	40,000
Roof Plan A-131	Included	Included	-----	Included	Included	Included
Flexible Flashing and Underlayment	Included	Included	-----	Included	Included	Included
Underlayment Single-ply self adhesive Waterproofing membrane per 09 2200.2.02.K	Included	Included	-----	Included	Included	Included
MFR - WR Grace, Jiffy-Seal or equal	Included	Included	-----	Included	Included	Included
Include membrane behind joints & backing at items exposed to weather, under metal copings & flashings & window jambs & sills per spec	Included	Included	-----	Included	Included	Included
Roof Details Sheet A-500:	Included	Included	-----	Included	Included	Included
Parapet Coping w/ cont cleat both sides - 22 Ga - 2/A-500	Included	Included	-----	Included	Included	Included
Flashing at mechanical unit curbs - 4/A-500 Not clearly shown	Included	Included	-----	Included	Included	Included
Roof penetration at Ducts flashing - 5/A-500	Included	Included	-----	Included	Included	Included
Flash at Pipes penetrations - 6/A-500	Included	Included	-----	Included	Included	Included
Flash at Exhaust duct - 9/A-500	Included	Included	-----	Included	Included	Included
Flash at roof access hatch - 10/A-500	Included	Included	-----	Included	Included	Included
Flash at fascias - 5/A-501	Included	Included	-----	Included	Included	Included
Flash at upper roof exterior soffits - 6/A-501	Included	Excluded	-----	Included	Included	Included
Flash at roof opening details 7/A-501, 20 ga cont cleat	Included	Included	-----	Included	Included	Included
Cap sloped on cement plaster beam 22 ga gsm w/ cont cleats both sides 10/A-510	Included	Included	-----	Included	Included	Included
Door & Window Sill/Head Flashings - 1.2/A-5120	Included	Included	-----	Included	Included	Included
Door head flashing - 10-12/A-520	Included	Included	-----	Included	Included	Included
Metal Corner trims at jambs of Sectional Garage doors - 12/A-521	Included	Included	-----	Included	Included	Included
Balcony Flashing at 2nd Floor deck guardrail - 15/A-560	Included	Included	-----	Included	Included	Included
Roof to plaster conditions	Included	Included	-----	6,400	Included	9,010
Gutters & Downspouts - None Shown	Included	Included	-----	Included	Included	Included

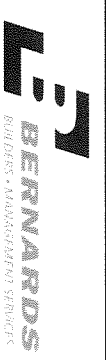

Sheet Metal & Metal Panels

Marshall Classroom Building

Job Number	1641
Bid Date	6/7/2017
Date Printed	7/27/2017
Patriot Contracting	Valencia Sheet Metal

Description	Subcontractors				Job Number	Date Printed	Patriot Contracting	Valencia Sheet Metal
	R&J SM	Letner	Commercial Roofing	Merit Metal Products				
Galvanized, Rectangular Shaped, from flat roofs, not shown	10,000	10,000	-----	10,000	10,000	10,000	Included	Included
Connects to storm drains systems, not shown	Included	Included	-----	Included	Included	Included	Included	Included
Roof Drains are internal pipes by plumber	Included	Included	-----	Included	Included	Included	Included	Included
Mechanical Equipment pad covers - None Shown	N/A	N/A	-----	N/A	N/A	N/A	N/A	N/A
Work at Outside Storage Unit per 07 6000 1.01B.9	N/A	N/A	-----	N/A	N/A	N/A	N/A	N/A
Roof Hatch	7,122	Included	No Bid	Included	Included	Included	Included	Included
Roof Plan A-131, Keynote 07.08 Roof Access Hatch 108.12/A-500, 30"x42" min size	Included	Included	-----	Included	Included	Included	Included	Included
MFR - Acudor, Bilco, Dur-Red, Milcor - Not Listed	Included	Included	-----	Included	Included	Included	Included	Included
Prefab Curb by MFR	Included	Included	-----	Included	Included	Included	Included	Included
Installed in Electrical Room 206	Included	Included	-----	Included	Included	Included	Included	Included
Metal Roofing	159,537	Included	202,181	84,000	Included	Included	Included	Included
Roof Plan A-131, Keynote 07.25 Standing Seam Metal Roof 10/A-501	Included	Included	Included	Included	Included	Included	Included	Included
Typical Standing Mtl roof detail 10/A-5010	Included	Included	Included	Included	Included	Included	Included	Included
MFR AEP Span, SpanLok	Included	Included	Included	Alt Prod: Metal Sales	Included	Included	Included	Alt Prod: Metal Sales
Per Specs call for 20 ga. / All bids are calling for 22 ga., so 22ga is basis of bid	Included	Incl 24ga	Included	Included	Included	Included	Included	Included
30#lb felt underlayment over roof plywood(by others)	Included	Included	Included	Included	Included	Included	Included	Included
Standing seam roof panels fastened w/ 1-1/2" pancake head screws	Included	Included	Included	Included	Included	Included	Included	Included
Flash standing seam at Fascia - 5/A-501	Included	Included	Included	Included	Included	Included	Included	Included
Flash Fascia 2 at standing seam 9/A-501	Included	Included	Included	Included	Included	Included	Included	Included
Gutters & Downspouts - None Shown - at low side of standing seam roofs	Included	Not shown	Included	Not shown	Not shown	Not shown	Not shown	Not shown
Downspouts to be sch40 pipe & galv downspouts to flat roofs	Included	Included	Included	Included	Included	Included	Included	Included
Waste Disposal	3,400	3,400	3,400	3,400	3,400	3,400	3,400	3,400
Provide Alternate Add if not in base bid	-----	14,000	Included	8,500	15,000	9,000		
Wall Louvers								
As listed /shown on Mechanical	w/ HVAC Metal Roof SM	w/ HVAC Metal Roof SM	w/ HVAC Metal Roof Only No SM	w/ HVAC Alt Metal Roof SM	w/ HVAC Metal Roof SM	w/ HVAC Alt Metal Roof SM		
TOTALS	236,257	195,350	205,581	160,900	217,570	175,290		
Recommendation:	Amount							
Merit Metal Products	160,900							

Bid Evaluation Report

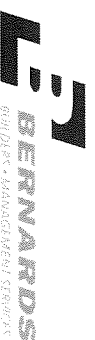

Sheet Metal & Metal Panels

Marshall Classroom Building

Subcontractors

Job Number: 1641
 Bid Date: 6/7/2017
 Date Printed: 7/27/2017

Description	Craig Roofing	Chapman Coast			
Base Bid	See below	0			
Spec #: 07 4000 - Metal Roof Panels	Included	SM only			
Bond Rate (if required)	Included	w/roofing bid			
	Bond @ 2.5%				
Furnished, Installed, FOB jobsite, Tax Included	Included				
Plans and Specs Dated: 1/28/2016 & 10/4/2016	Included				
Acknowledgment of RFIs 1-75 dated 6.5.17	Included				
Bid Good for 60 Days	30 Days				
Prevailing Wage	Included				
Prequalified per Oxnard School District Standards	N/A				
Attachment C Acknowledgement	N/A				
Sheet Metal					
Exterior Elevations A-210, A-211; Building Sections A-310, 311, 320, 321, 322	Included	9,550			
Roof Plan A-131	Included				
Flexible Flashing and Underlayment	Included				
Underlayment Single-ply self adhesive Waterproofing membrane per 09 2200.2.02.K	Included				
MFR - WR Grace, Jiffy-Seal or equal	Included				
Include membrane behind joints & backing at items exposed to weather, under metal copings & flashings & window jambs & sills per spec	Included				
Roof Details Sheet A-500:	Included				
Parapet Coping w/ cont cleat both sides - 22 Ga - 2/A-500	Included				
Flashing at mechanical unit curbs - 4/A-500 Not clearly shown	Included				
Roof penetration at Ducts Flashing - 5/A-500	Included				
Flash at Pipes penetrations - 6/A-500	Included				
Flash at Exhaust duct - 9/A-500	Included				
Flash at roof access hatch - 10/A-500	Included				
Flash at fascias - 5/A-501	Included				
Flash at upper roof exterior soffits - 6/A-501	Included				
Flash at roof opening details 7/A-501, 20 ga cont cleat	Included				
Cap sloped on cement plaster beam 22 ga gsm w/ cont cleats both sides 10/A-510	Included				
Door & Window Sill/Head Flashings - 1.2/A-5120	Included				
Door head flashing - 10-12/A-520	Included				
Metal Corner trims at jambs of Sectional Garage doors - 12/A-521	Included				
Balcony Flashing at 2nd Floor deck guardrail - 15/A-560	Included				
Roof to plaster conditions	9,000				
Gutters & Downspouts - None Shown	Included				

Bid Evaluation Report



Sheet Metal & Metal Panels

Marshall Classroom Building

Subcontractors

Job Number 1641
 Bid Date 6/7/2017
 Date Printed 7/27/2017

Description	Craig Roofing	Chapman Coast				
Galvanized, Rectangular Shaped, from flat roofs, not shown	10,000					
Connects to storm drains systems, not shown	Included					
Roof Drains are internal pipes by plumber	Included					
Mechanical Equipment pad covers - None Shown	N/A					
Work at Outside Storage Unit per 07 6000 I.01B.9	N/A					
Roof Hatch	Included					
Roof Plan A-131, Keynote 07.08 Roof Access Hatch	Included					
10&12/A-500, 30"x42" min size	Included					
MFR - Acudor, Blico, Dur-Red, Millicor - Not Listed	Included					
Prefab Curb by MFR	Included					
Installed in Electrical Room 206	Included					
Metal Roofing	218,820					
Roof Plan A-131, Keynote 07.25 Standing Seam Metal Roof 10/A-501	Included					
Typical Standing Mt roof detail 10/A-5010	Included					
MFR AEP Span, SpanLok	Included					
Per Specs call for 20 ga. / All bids are calling for 22 ga., so 22ga is basis of bid	Included					
30#lb felt underlayment over roof plywood(by others)	Included					
Standing seam roof panels fastened w/ 1-1/2" pancake head screws	Included					
Flash standing seam at Fascia - 5/A-501	Included					
Flash Fascia 2 at standing seam 9/A-501	Included					
Gutters & Downspouts - None Shown - at low side of standing seam roofs	Included					
Downspouts to be sch40 pipe & galv downspouts to flat roofs	Included					
Waste Disposal	-----					
Provide Alternate Add if not in base bid						
Wall Louvers	0					
As listed /shown on Mechanical	w/ HVAC Metal Roof SM	No Metal Roof SM Only				
TOTALS	275,928	0	0	0	0	0
Recommendation:	Amount					
Merit Metal Products	160,900					

Bid Evaluation Report



Roofing

Marshall Classroom Building

Subcontractors

Description	Best Contracting	Chapman Coast	Commercial Roofing	Craig Roofing	Letner Roofing	WSP Roofing	Job Number	1641
							Bid Date	6/7/2017
							Date Printed	7/27/2017
Base Bid	124,725	153,939	145,717	199,708	211,750	129,179		
Spec #: 07 5416 - Polyvinyl Chloride (PVC) Roofing (Mechanically Attached)	Included	Included	Included	Included	Included	Included		
Bond Rate (if required)								
Furnished, Installed, FOB Jobsite, Tax Included	Included	Included	Included	Included	Included	Included		
Plans and Specs Dated: 1/28/2016 & 10/4/2016	Bond @ 1%	Bond @ 1.5%	Bond @ 1.5%	Bond @ 1.5%	Bond @ 1.5%	Bond @ 1.5%		
Acknowledgment of RFI's 1-75 dated 6.5.17	Included	Included	Included	Included	Included	Included		
Bid Good for 60 Days	30 days	60 Days	60 Days	45 days	60 Days	Included		
Prevailing Wage	Included	Included	Included	Included	Included	Included		
Prequalified per Oxnard School District Standards	N/A	N/A	N/A	N/A	N/A	N/A		
Polyvinyl-Chloride (PVC) Roofing	Included	Included	Included	Included	Included	Included		
Roof Plan A-131, Keynote 07.01 Single-Ply Roof Assembly see 1/A-500	Included	Included	Included	Included	Included	Included		
MFR - Sika Sarnafil, Johns Manville, Carlisle or Equal	Sarnafil	Carlisle	Sarnafil	Included	Included	Included		
BOD Sarnafil S327 FB, thermoplastic membrane w/ poly reinforcement & feltback membrane	Included	Included	Included	Included	Included	Included		
Single Ply Roofing System 60 mill without fleece backing, color to be White	Included 7,000 sf	Included 6,600sf	Included	Included	Included 7,000sf	Included 7,000sf		
Fully Adhered	Included	Included	Included	Included	Included	Included		
Mechanically Fastened	Included	Included	Included	Included	Included	Included		
R-30 Rigid Isoocyanurate foam Insulation w/ black mat facers	Included	Included	Included	Included	Included	Included		
Tapered crickets w/ Insulation	Included	Included	Included	Included	Included	Included		
1/2" DensDeck Coverboard at Roof	Included	Included	Included	Included	Included	Included		
Include all attachment components & flashing materials	Included	Included	Included	Included	Included	Included		
Include misc flashing at pipes, corners coverstrips, termination bars	Included	Included	Included	Included	Included	Included		
Include all sealants	Included	Included	Included	Included	Included	Included		
Safety walk and progressive cleanup	4,640	4,640	4,640	4,640	4,640	4,640		
Walk Pads - Per Roofing Plans	Included	Included	Included	Included	Included	Included		
Polyester reinforced, 0.096 inch weldable membrane w/ surface embossment per spec 2.07.A	Included	Included	Included	Included	Included	Included		
Parapet walls to be plaster	Included	Included	Included	Included	Included	Included		
Waste disposal	4,250	4,250	4,250	4,250	4,250	4,250		
Warranty to be 10-yr NDL Material & Labor warranty	Included	Included	Included	Included	Included	Included		
ARC.9	(4,800)	(4,500)	(4,500)	(4,500)	(4,500)	(4,500)		
ARC.17	(10,280)	(10,000)	(10,000)	(10,000)	(10,000)	(10,000)		
TOTALS	118,535	148,329	140,107	194,098	206,140	123,569		
Recommendation:	Amount							

Bid Evaluation Report



Roofing		Marshall Classroom Building			Job Number	1641
		Subcontractors			Bid Date	6/7/2017
					Date Printed	7/27/2017
Description	Best Contracting	Chapman Coast	Commercial Roofing	Craig Roofing	Letner Roofing	WSP Roofing
Best Contracting	118,535					



Bid Evaluation Report

Doors, Frames & Hardware

Marshall Classroom Building

Subcontractors

Description	Construction Hardware	Design Hardware	RK&G Construction	Star Hardware	Estrada Hardware	Job Number	1641
						Bid Date	6/7/2017
						Date Printed	7/27/2017
Base Bid	99,420	113,689	132,696	102,265	115,060		
Spec #: 08 1113 - Hollow Metal Doors and Frames	Included	Included	Included	Included	Included		
Spec #: 08 1416 - Flush Wood Doors	Included	Included	Included	Included	Included		
Spec #: 08 3116 - Access Panels & Frames	Included	Included	Included	Included	Included		
Spec #: 08 3613 - Sectional Doors	Included	Included	Included	Included	Included		
Spec #: 08 7100 - Door Hardware	Included	Included	Included	Included	Included		
Bond Rate (if required)	Bond @1.5%	Bond @1.5%	Bond @2.5%				
Furnished, Installed, FOB Jobsite, Tax Included	Included	Included	Included	Included	Included		
Plans and Specs Dated: 1/28/2016 & 10/4/2016	Included	Included	Included	Included	Included		
Acknowledgment of RFIs 1-75 dated 6.5.17	Included	Included	Included	Included	Included		
Bid Good for 60 Days	60 Days	60 Days	30 days	Included	Included		
Prevailing Wage	Included	Included	Included	Included	Included		
Prequalified per Oxnard School District Standards	N/A	N/A	N/A	N/A	N/A		
Attachment C Acknowledgement	N/A	N/A	N/A	N/A	N/A		
Hollow Metal Doors and Frames	Included	Included	Included	Included	Included		
MFR per Specs	Included	Included	Included	Included	Included		
Frame Details - A-520	Included	Included	Included	Included	Included		
New Classroom Building - 1st & 2nd fl	Included	Included	Included	Included	Included		
HM Frames ()	Included	Included	Included	Included	Included		
Type A	Included	Included	Included	Included	Included		
Type B	Included	Included	Included	Included	Included		
Type C	w/ Spec Drs	w/ Spec Drs	w/ Spec Drs	w/ Spec Drs	w/ Spec Drs		
Type D, Marker Board Sliding Door Schedule	Included	Included	Included	Included	Included		
Type E - w/ Louver	Included	Included	Included	Included	Included		
HM Doors (30)	Included	Included	Included	Included	Included		
Wood Doors (3)	Included	Included	Included	Included	Included		
Install HM Doors	Included	Included	Included	Included	Included		
Install HM Frames	Included	8,500	8,500	8,500	6,350		
Install Wood Doors	Included	Included	Included	Included	Included		
Glass for Vision Lites & Windows	3,375	3,750	3,750	3,750	3,375		
Door Hardware	Included	Included	Included	Included	Included		
Hardware per Schedule in Specs	Included	Included	Included	Included	Included		
Safety walk and progressive cleanup	2,320	2,320	2,320	2,320	2,320		
Door Thresholds	Included	Included	Included	Included	Included		
Misc. Door Hardware - Site Gates	Included	Included	Included	Included	Included		
Storefront Doors - None Shown	Included	Included	Included	Included	Included		
Panic Hardware at Gates - per Accessibility Site Plan - G-004	Included	Included	Included	Included	Included		
Hardware at existing Gates per Gate Schedule, G-004	Included	Included	Included	Included	Included		

Bid Evaluation Report



Doors, Frames & Hardware

Marshall Classroom Building

Subcontractors

Description	Construction Hardware	Design Hardware	RK&G Construction	Star Hardware	Job Number	
					Estrada Hardware	1641
						Bid Date
						Date Printed
Door G, 520A & 520B - Exit only panic hdwr on push side, key lock on pull side	3,475	5,250	5,250	5,250	3,475	6/7/2017
Doors 5-1, 5-2, 5-6, 514A: Exit only panic hdwr on push side, key lock side	4,690	4,690	4,690	4,690	4,690	7/27/2017
ARC:26	(3,170)	(3,000)	(3,000)	(3,000)	(3,000)	
TOTALS	110,110	135,199	154,206	123,775	132,270	0
Recommendation:	Amount					
Construction Hardware	110,110					

Bid Evaluation Report



Glass & Glazing

Marshall Classroom Building

Subcontractors

Description	Santa Barbara Glass			Center Glass			Coast to Coast		
	Job Number	Bid Date	1641	Job Number	Bid Date	1641	Job Number	Bid Date	1641
Base Bid			79,908			86,300			
Spec #: 08 5113 - Aluminum Windows			Included			Included			
Spec #: 08 7100 - Door Hardware			N/A			N/A			
Spec #: 08 8000 - Glazing			Included			Included			
Bond Rate (if required)			Included			Included			
Furnished, Installed, FOB Jobsite, Tax Included			Included			Included			
Plans and Specs Dated: 1/28/2016 & 10/4/2016			Included			Included			
Acknowledgment of RFIs 1-75 dated 6.5.17			Included			Included			
Bid Good for 60 Days			Included			30 days			
Prevailing Wage			Included			Included			
Prequalified per Oxnard School District Standards			N/A			N/A			
Aluminum Windows			Included			Included			
Double and Single Hung Windows			Included			Included			
Acceptable Manufacturers for Aluminum Windows			Included			Included			
Efco Series 684 & 694			Included			Series 2700			
Traco TR-9000			Included			Excluded			
Graham Series 3000/3100			Included			Excluded			
Peerless Model 4340 & 4140			Included			Included			
New Classroom Bldg - A-111, A-112			Included			Included			
Type A - 5' x 2'-1"			Included			Included			
Type B - 3' x 6'			Included			Included			
Type C - 5' x 6'			Included			Included			
Type D - 5' x 6'			Included			Included			
Type E - 3' x 8'			Included			Included			
Type F - 5' x 8'			Included			Included			
Type G - 5' x 6'			Included			Included			
Type H - 5' x 6'			Included			Included			
Type I - 3' x 6'			Included			Included			
Sealing and Caulking for All Window/Door Systems per Arch Details			3,775			3,775			
Glazing			Included			Included			
Glass for Vision Lites & Windows			3,750			Included			
Include SG - Safety Glazing as Indicated on Window Schedule A-610, per spec 08800			Included			Included			
Include OB - Obscured Glazing as Indicated on Window Schedule A-610, per spec 08800			Included			Included			
Other									
Field Testing for Water Penetration AAMA E1105, assume 6 ea			4,500			4,500			
Mock-Up			1,250			1,250			
ARC.1			24,998			25,000			
ARC.22			(4,094)			(4,000)			
TOTALS			114,087			116,825			0

Bid Evaluation Report



Glass & Glazing	Marshall Classroom Building			Job Number	1641
				Bid Date	6/7/2017
	Subcontractors			Date Printed	7/27/2017
Description				Santa Barbara Glass	Center Glass
	Amount				
Recommendation:	Santa Barbara Glass			114,087	

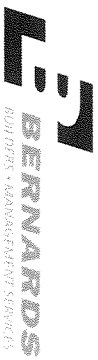

Bid Evaluation Report

Plaster & Drywall

Marshall Classroom Building

Description	Subcontractors				Perlite Plastering	Pacific Interiors
	Best Interiors	Standard Drywall	Church and Larsen	Premier Drywall		
Base Bid	See Below	See Below	See Below	Drywall Only	Plaster Only	Dywall Only
Spec #: 07 8400 - Fire Stop and Smoke Seals	Included	Included	Included	N/A	N/A	N/A
Spec #: 07 9200 - Joint Sealants	Included	Included	Included	N/A	N/A	N/A
Spec #: 09 2200 - Cement Plastering	Included	Included	Included	N/A	Included	N/A
Spec #: 09 2900 - Gypsum Board	Included	Included	Included	Included	N/A	Included
Spec #: 078400, 083100, 072500	Included	Included	Included	N/A	N/A	N/A
Bond Rate (if required)						
Furnished, Installed, FOB Jobsite, Tax Included	Included	Included	Included	Included	Included	Included
Plans and Specs Dated: 1/28/2016 & 10/4/2016	Included	Included	Included	Included	Included	Included
Acknowledgment of RFIs 1-75 dated 6.5.17	Included	Included	Included	Included	Included	Included
Bid Good for 60 Days	30 Days	30 Dyas	30 Dyas	90 Dyas	30 Dyas	Included
Prevailing Wage	Included	Included	Included	Included	Included	Included
Prequalified per Oxnard School District Standards	N/A	N/A	N/A	N/A	N/A	N/A
Attachment C Acknowledgement	N/A	N/A	N/A	N/A	N/A	N/A
Plaster	436,210	428,681	289,224	334,700	334,700	334,700
Exterior Elevations A-210, A-211; Building Sections A-310, 311, 320, 321, 322	Included	Included	Included		Included	
Keystone 09.11-Portland Cement Plaster and Metal Lath, per wall types	Included	Included	Included		Included	
Texture - Dash Bond Coat 09 2200,3.06,G	Included	Included	Included		Included	
Exterior Plaster Ceilings and Soffits per typ det 11/A-501	Included	Included	Included		Included	
Exterior Plaster at parapets 2/A-500	Included	Included	Included		Included	
Interior Plaster per specs, Include if any shown on drawings	Included	Included	Included		Included	
Foam Trim Pieces at Windows if shown to be foam	Included	Included	Included		Included	
Water resistant backing behind metal lath - 09 2200,2.01,E	Included	Included	Included		Included	
Paper Grade D, 60--min rating on wood studs without sheathing, and on plywood sheathing	Included	Included	Included		Included	
Paper Grade B, 16--hour rating on gypsum sheathing	Included	Included	Included		Included	
MFR - Fortifiber, Super Jumbo Tex,USG, Inryco or Western Metal Lath	Included	Included	Included		Included	
2-Layers Grade D Kraft Paper	Included	Included	Included		Included	
3-Coat System	Included	Included	Included		Included	
Glass Fiber Reinforcement	Included	Included	Included		Included	
Lath & Paper	Included	Included	Included		Included	
Ribbed Lath at Plaster Ceilings & Soffits	Included	Included	Included		Included	
Strongnoid earthquake staples for metal lath at plaster ceilings & soffits 11/A-501, 16/A-502	Included	Included	Included		Included	
Expansion/Control Joints 9/A-510	Included	Included	Included		Included	
Plaster Trim	Included	Included	Included		Included	

Bid Evaluation Report



Plaster & Drywall	Marshall Classroom Building				Job Number	1641
	Subcontractors				Bid Date	6/7/2017
Description	Best Interiors	Standard Drywall	Church and Larsen	Premier Drywall	Date Printed	7/27/2017
					Perlite Plastering	Pacific Interiors
Vent & Weep Screeds - 15/A-560	Included	Included	Included		Included	
Corner Bead - 13/A-510	Included	Included	Included		Included	
Ceiling expansion joints - 15/A-510	Included	Included	Included		Included	
Plaster Stops - 5/A-501	Included	Included	Included		Included	
Underlayment Single-ply self adhesive Waterproofing membrane per 09 2200.2.02.K	70,000	62,686	70,000	70,000	70,000	70,000
MFR - WR Grace, Jiffy-Seal or equal	Included	Included	Included		Included	
Include membrane behind joints & backing at items exposed to weather, under metal copings & flashings & window jambs & sills per spec	Included	Included	Included		Included	
Provide vertical Control Joint at each side of the double windows, full ht. south, west and east elevation. Provide horizontal CJ at the bottom of the upper window (aff. +17'-6") to line-up with window sill. Reference details 5 & 9/A-510 (RFI #14)	Included	Included	Included		Included	
All roof parapet walls (interior) and mechanical wall walls to have plaster finish, typical. Ref. detail 2/A-500. (RFI #15)	Included	Included	Included		Included	
Safety walk and progressive cleanup	11,600	11,600	11,600		11,600	
Patching, Taping, Floating as Required	Included	Included	Included		Included	
All Required Caulking and Sealants at Penetrations	Included	Included	Included		Included	
Scaffolding for Own Work	90 Days	107,323	Included		Included	
Trade Damage - Plaster (40 Hours)	5,400	5,400	5,400	5,400	5,400	5,400
Drywall						
Drywall per Wall Types Sheet - A-620	203,565	233,312	196,876	278,790	233,555	233,555
This wall job is drywall over wood, no metal studs	Included	Included	Included	Included	Included	Included
Wall type A - 1 layer ea side	Included	Included	Included	Included	Included	Included
Wall type B - double stud walls 1 layer ea side	Included	Included	Included	Included	Included	Included
Wall type C - shear wall 1 layer ea side	Included	Included	Included	Included	Included	Included
Wall type D - 1-hr wall 1 layer ea side	Included	Included	Included	Included	Included	Included
Wall type E1 - 1-hr wall 1 layer ea side	Included	Included	Included	Included	Included	Included
Wall type F - 1 layer ea side	Included	Included	Included	Included	Included	Included
Wall type G - ext wall (plywood ea side by others) 1 layer on int, plaster over plywood ext	Included	Included	Included	Included	Included	Included
Wall type H - 2 layers ea side	Included	Included	Included	Included	Included	Included
Wall type I - 2 layers ea side (over plywood ea side by others)	Included	Included	Included	Included	Included	Included
Wall type K - acoustic wall double wood wall, 1 layer ea side, not on int side of double wall	Included	Included	Included	Included	Included	Included
Wall type N - int furred wall, 1 layer on one side	Included	Included	Included	Included	Included	Included

Bid Evaluation Report

Plaster & Drywall

Marshall Classroom Building

Description	Subcontractors				Perlite Plastering	Pacific Interiors
	Best Interiors	Standard Drywall	Church and Larsen	Premier Drywall		
	Job Number Bid Date	Date Printed	1641 6/7/2017	7/27/2017		
Wall type O - ext wall (plywood ea side by others) 1 layer on int, plaster over plywood ext	Included	Included	Included	Included		Included
Drywall Ceilings per Reflected Ceiling Plans A-121 to A-122	Included	Included	Included	Included		Included
See sections on sheets A-321-322 for ceiling info	Included	Included	Included	Included		Included
This ceiling job is drywall over wood, there a few areas there is metal framed ceilings?	Included	Included	Included	Included		Included
Finish Schedule A-612, ACT-1 in Classrooms as listed	Included	Included	Included	Included		Included
Impact resistant gypsum board below 10'-0" per Note 2 on Finish Legend A-612	5,000	5,000	Included	5,000		5,000
5/8" Drywall Horizontal & Vertical surfaces	Included	Included	Included	Included		Included
Cement Backerboard at Restroom Walls	Included	Included	Included	Included		Included
Level 1-5 Finish at Locations per Specifications Based on Paint or Wall Finish spec 09 2900.3.04.A	Level 4&2	Level 4	Level 4	Included		Included
Metal trims, joint treatments & finishing of walls ready for paint	Included	Included	Included	Included		Included
Texture & skim coats where indicated	Included	Included	Included	Included		Included
Clean-up	Included	Included	Included	Included		Included
Fire Resistant Sealants at Head and Base of Walls	Included	Included	Included	Included		Included
Acoustic Sealants as Shown and Spec'd	Included	Included	Included	Included		Included
Installation of HM Door Frames Supplied by Others	w/ DFH	w/ DFH	w/ DFH	w/ DFH		w/ DFH
Supply and Install of Access Panels 12x12	3,000	3,000	3,000	3,000		3,000
Installation of FEC Supplied by Others	1,350	1,350	1,350	1,350		1,350
Install drywall at elevator door frames after they are installed (by others)	1,500	1,500	1,500	1,500		1,500
Install ceiling at elevator room, not shown	1,000	1,000	1,000	1,000		1,000
Drywall Pickup	Included	Included	Included	Included		Included
Hoisting for Own Work	Included	Included	Included	Included		Included
Scraping and Disposal	6,375	6,375	6,375	6,375		6,375
Trade Damage - Drywall (80 Hours)	10,800	10,800	10,800	10,800		10,800
Fire Stops and Smoke Seals						
Mineral fiber insulation fire safing, damming material, clips and closures	7,551	7,551	7,551	7,551		7,551
Seal openings in floors, fire rated walls & penetrations	Included	Included	Included	Included		Included
At pipes, ducts, conduits & other items shown	Included	Included	Included	Included		Included
MFR - Bio Fireshield, 3M, GE or Nelson	Included	Included	Included	Included		Included
Sealants, firestop putty, mortar, pillows, mineral fiber safing	Included	Included	Included	Included		Included
ARC.1	9,250	9,250	9,025	9,250		9,250
ARC.17	(10,000)	(10,000)	(10,300)	(10,000)		(10,000)

Bid Evaluation Report

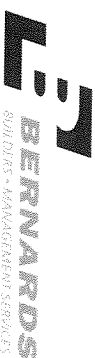

Plaster & Drywall

Marshall Classroom Building

Description	Subcontractors				Job Number	1641
	Best Interiors	Standard Drywall	Church and Larsen	Premier Drywall	Bid Date	6/7/2017
ARC:20	(70,000)	(62,682)	(70,000)	(70,000)	Date Printed	7/27/2017
ARC:20	5,000	5,000	4,945	5,000	Perlite Plastering	Pacific Interiors
					(70,000)	(70,000)
					5,000	5,000
TOTALS	697,601	827,146	538,346	659,716	621,081	653,005
Recommendation:	Amount					
Church and Larsen	538,346					

Bid Evaluation Report

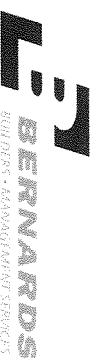

Title

Marshall Classroom Building

Job Number 1641

Bid Date 6/7/2017

Date Printed 7/27/2017

Description

Subcontractors

Stonerock Tile

J. Colavin & Son

Silverado Tile

Base Bid	99,325	110,210	91,500	0		
Spec #: 09 3013 - Ceramic Tiling	Included	Included	Included			
Furnished, Installed, FOB Jobsite, Tax Included	Included	Included	Included			
Plans and Specs Dated: 1/28/2016 & 10/4/2016	Included	Included	Included			
Acknowledgment of RFIs 1-75 dated 6.5.17	Included	Included	Included			
Bid Good for 60 Days	30 Days	90 Days	90 Days			
Prevailing Wage	Included	Included	Included			
Prequalified per Oxnard School District Standards	N/A	N/A	N/A			
Attachment C Acknowledgement	N/A	N/A	N/A			
Title	Included	Included	Included			
Finish Schedule A-612:	Included	Included	Included			
F3-Non-slip Ceramic Tile	Included	Included	Included			
B2-Coved Ceramic Tile Base	Included	Included	Included			
W1-Ceramic Tile Walls	Included	Included	Included			
MFR - Dal-Tile	Included	Included	Included			
DalTile Keystone 1"x1" Mosaic - Floors	Included	Included	Included			
DalTile Semi Gloss 6"x6" - Walls	Included	Included	Included			
Marble Thresholds	1,500	1,500	1,500			
Setting beds - Mortar and thinset	Included	Included	Included			
GROUT - Standard, Polymer modified, or Epoxy Grout - not spelled out in spec	Std grout	Std grout	Std grout			
Add for epoxy grout	Not provided	Not provided	Add: \$7,650			
Grout Sealer	4,085	Included	Included			
Waterproofing Membrane at depression - 283/A-510	Included	Included	Included			
Waterproofing type, 6 are listed in specs, 093013.9.2.1 2.6, which one do you have in your bid?	RedGuard	Included	RedGuard			
Wall Tile on 5/8" Cementitious Backer Board (by others) - 283/A-510	By Others	By Others	By Others			
Install per CTI Method W244, thinset method	Included	Included	Included			
Floor Tile on depressed concrete slab (by others) - 283/A-510	By Others	By Others	By Others			
Install per CTI Method F114, mudset/mortaset method	Included	Included	Included			
Locations:	Included	Included	Included			
Boys Toilet rm 110, 210	Included	Included	Included			
Boys Changing rm 111	Included	Included	Included			
Girls Toilet rms 113, 212	Included	Included	Included			
Girls Changing rm 114	Included	Included	Included			
Staff Toilet rms 112, 211	Included	Included	Included			

Bid Evaluation Report

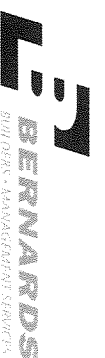

Title

Marshall Classroom Building

Job Number

1641

Bid Date

6/7/2017

Date Printed

7/27/2017

Description	Subcontractors			Amount
	Stonerock Tile	J. Colavin & Son	Silverado Tile	
Interior Elevations A-224	Included	Included	Included	
8' Ht Tile Mainscot (RFI # 24)	Included	Included	Included	
Safety walk and progressive cleanup	2,320	2,320	2,320	
Include Tile Behind Lockers, Provide Alternate Deduct to Remove	Included	Included	Included	
ARC:7	(21,500)	(21,500)	(21,670)	
ARC:16	(6,000)	(6,000)	(6,240)	
ARC:18	(16,000)	(16,000)	(16,290)	
TOTALS	63,730	70,530	51,120	0
Recommendation:	Amount			
Silverado Tile	51,120			

Bid Evaluation Report

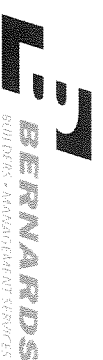

Acoustical Ceilings

Marshall Classroom Building

Description	Subcontractors				Job Number	1641
	Alert Insulation	Standard Drywall	Commercial Interiors	CG Chaney	Bid Date	6/7/2017
					Date Printed	7/27/2017
					Prime Acoustics	Hamilton Ceiling Systems
Base Bid	41,500	53,030	42,490	35,775	36,000	43,700
Spec #: 09 5123 - Acoustical Tile Ceilings	Included	Included	Included	Included	Included	Included
Spec #: 09 8434 - Acoustical Wall Panels (from RFI #7)					Included	
Furnished, Installed, FOB Jobsite, Tax Included	Included	Included	Included	Included	Included	Included
Plans and Specs Dated: 1/28/2016 & 10/4/2016	Included	Included	Included	Included	Included	Included
Acknowledgment of RFI's 1-75 dated 6.5.17	Included	Included	Included	Included	Included	Included
Bid Good for 60 Days	30 Days	30 Days	30 Days	Included	Included	Included
Prevailing Wage	Included	Included	Included	Included	Included	Included
Prequalified per Oxnard School District Standards	N/A	N/A	N/A	N/A	N/A	N/A
Attachment C Acknowledgement	N/A	N/A	N/A	N/A	N/A	N/A
Acoustical Panel Ceilings						
Reflected Ceiling Plans A-121 to A-122	Included	Included	Included	Included	Included	Included
Finish Schedule A-612, ACT-1 in Classrooms as listed	Included	Included	Included	Included	Included	Included
MFR - Armstrong, CertainTeed or USG	USG	Included	Included	USG	CertainTeed	CertainTeed
Armstrong Fine Fissured, White, No Pattern, 3/4" Thick 24"x48"	Included	Included	Included	Included	Included	Included
Grid - Prelude XL 15/16" Exposed Tee by Armstrong	DXL 26	Included	Included	Included	Included	Included
ACT Details per A-540	Included	Included	Included	Included	Included	Included
Include vertical struts, wall molding,space/stabilizer bars, hanger wire & attachment devices	Included	Included	Included	Included	Included	Included
Include Compression struts per 2/A-540	Included	Included	Included	Included	Included	Included
Read and abide by all Notes on sheet	Included	Included	Included	Included	Included	Included
Safety walk and progressive cleanup	2,320	2,320	2,320	2,320	2,320	2,320
Include extra hanger wires for lighting fixtures, hvac registers & diffusers	600	600	600	600	Included	Included
ACT Panel w/ "L" moulding on face of soffit at ceiling ht change per 2/A-501	Included	Included	Included	Included	Included	Included
Acoustical Wall Panels						
Spec provided in RFI#7 - Acoustical Wall Panels 09 8434	34,660	34,660	34,660	34,660	24,400	34,660
AWP Type 1, Keynote 10.54					Included	
MFR - Guilford FR-701 screen fabric, pattern 2100, 1" Thickness, 16.0+/ly weight					Included	
Tackable Wall Panels					10,000	
Finish Schedule A-612:					Included	

Bid Evaluation Report



Acoustical Ceilings

Marshall Classroom Building

Description	Alert Insulation	Subcontractors			Prime Acoustics	Hamilton Ceiling Systems
		Standard Drywall	Commercial Interiors	CG Chaney		
W5-Tackboard panel over gypsum board, Keynote 10.50					Included	
Color (not listed) provide per MFR standard color palette					Included	
Acoustical panels to be semi-rigid inorganic glass fiber material by Owens Corning, Johns Manville, Knauf or equal					Included	
Thickness of panels per Sound absorption coefficient requirement per tabulated values 09 8434,1.03,D					Included	
Provide cutouts in panels for plates, receptacles, outlets, switches, tstats, clocks, lights, etc.					Included	
Include all mounting hardware, concealed types, individually removable					Included	
See the Typical Room Layouts for Learning Labs, Science Classrooms & Performing Arts Lab - 1,2,3/A410					Included	
Interior elevations at classrooms A-220					Included	
Tackboard Floor to Ceiling see 3/A-530					Included	
Detail 3/A530 shows a 5/8" Corkboard cover with wall covering & alum edge piece 14 ga. Min entire perimeter					Included	
Installed directly over drywall walls					Included (24,400)	
ARC:5						
TOTALS	79,080	90,610	80,070	73,355	48,320	80,680
Recommendation:	Amount					
Prime Acoustics	48,320					

Bid Evaluation Report

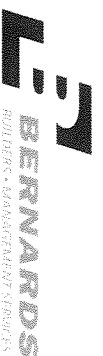

Acoustical Ceilings

Marshall Classroom Building

Subcontractors

Description	Ceiling Experts	Call-USA	Nelson Adams Naco	Tech-Wall	Job Number	1641
					Bid Date	6/7/2017
					Date Printed	7/27/2017
Base Bid	65,000	39,982	AWP Only	AWP Only		
Spec #: 09 5123 - Acoustical Tile Ceilings	N/A	Included	N/A	N/A		
	Included	Included	Included	Included		
Furnished, Installed, FOB Jobsite, Tax Included	Included	Included	Included	Included		
Plans and Specs Dated: 1/28/2016 & 10/4/2016	Included	Included	Included	Included		
Acknowledgment of RFI's 1-75 dated 6.5.17	Included	Included	Included	Included		
Bid Good for 60 Days	Included	30 Days	Included	Included		
Prevailing Wage	Included	Included	Included	Included		
Prequalified per Oxnard School District Standards	N/A	N/A	N/A	N/A		
Attachment C Acknowledgement	N/A	N/A	N/A	N/A		
Acoustical Panel Ceilings						
Reflected Ceiling Plans A-121 to A-122	Included	Included				
	Included	Included				
Finish Schedule A-612, ACT-1 in Classrooms as listed	Included	Included				
MFR - Armstrong, CertainTeed or USG	Armstrong	CertainTeed				
Armstrong Fine Fissured, White, No Pattern, 3/4" Thick 24"x48"	Included	Included				
Grid - Prelude XL 15/16" Exposed Tee by Armstrong	Included	Included				
ACT Details per A-540	Included	Included				
Include vertical struts, wall molding,space/stabilizer bars, hanger wire & attachment devices	Included	Included				
Include Compression struts per 2/A-540	Included	Included				
Read and abide by all Notes on sheet	Included	Included				
Include extra hanger wires for lighting fixtures, hvac registers & diffusers	600	600				
ACT Panel w/ "L" moulding on face of soffit at ceiling ht change per 2/A-501	Included	Included				
0						
Acoustical Wall Panels						
Spec provided in RFI#7 - Acoustical Wall Panels 09 8434	85,000	56,448	16,736	25,084		
AWP Type 1, Keynote 10.54	Included	Included	Included	Included		
MFR - Guilford FR-701 screen fabric, pattern 2100, 1" Thickness, 16.0+ /ly weight	Included	Included	9,000	Included		
Tackable Wall Panels	10,000	10,000	10,000	9,576		
Finish Schedule A-612:	Included	Included	Included	Included		

Bid Evaluation Report



Acoustical Ceilings

Marshall Classroom Building

Subcontractors

Description	Ceiling Experts	Call-USA	Subcontractors		Tech-Wall	Job Number	1641
			Nelson Adams Naco			Bid Date	6/7/2017
						Date Printed	7/27/2017
W5-Tackboard panel over gypsum board, Keynote 10.50	Included	Included	Included	Included	Included		
Color (not listed) provide per MFR standard color palette	Included	Included	Included	Included	Included		
Acoustical panels to be semi-rigid inorganic glass fiber material by Owens Corning, Johns Manville, Knauf or equal	Included	Included	Included	Included	Included		
Thickness of panels per Sound absorption coefficient requirement per tabulated values 09 8434,1.03,D	Included	Included	Included	Included	Included		
Provide cutouts in panels for plates, receptacles, outlets, switches, tstats, clocks, lights, etc.	Included	Included	Included	Included	Included		
Include all mounting hardware, concealed types, individually removable	Included	Included	Included	Included	Included		
See the Typical Room Layouts for Learning Labs, Science Classrooms & Performing Arts Lab - 1,2,3/A410	Included	Included	Included	Included	Included		
Interior elevations at classrooms A-220	Included	Included	Included	Included	Included		
Tackboard Floor to Ceiling see 3/A-530	Included	Included	Included	Included	Included		
Detail 3/A530 shows a 5/8" Corkboard cover with wall covering & alum edge piece 14 ga. Min entire perimeter	Included	Included	Included	Included	Included		
Installed directly over drywall walls	Included	Included	Included	Included	Included		
ARC.5							
TOTALS	160,600	107,030	35,736	34,660	0	0	0
			AWP Only	AWP Only			
Recommendation:	Amount						
Prime Acoustics	48,320						

Bid Evaluation Report

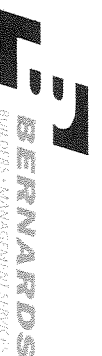

Carpet & Resilient Flooring

Marshall Classroom Building

Subcontractors

Job Number **1641**
 Bid Date **6/7/2017**
 Date Printed **7/27/2017**

Description	Subcontractors				Job Number	Bid Date	Date Printed
	Reliable Flooring	JJJ Flooring	Floor Tech America	Continental Flooring			
Base Bid	59,951	64,560	76,887	65,126			
Spec #: 09 6513 - Rubber Base	Included	Included	Included	Included			
Spec #: 09 6519 - Resilient Tile Flooring	Included	Included	Included	Included			
Furnished, Installed, FOB Jobsite, Tax Included	Included	Included	Included	Included			
Plans and Specs Dated: 1/28/2016 & 10/4/2016	Included	Included	Included	Included			
Acknowledgment of RFIs 1-75 dated 6.5.17	Included	Included	Included	Included			
Bid Good for 60 Days	30 Days	Included	Included	Included			
Prevailing Wage	Included	Included	Included	Included			
Prequalified per Oxnard School District Standards	N/A	N/A	N/A	N/A			
Attachment C Acknowledgement	N/A	N/A	N/A	N/A			
Flooring							
Minor Floor Prep	Included	Included	Included	Included			
Testing for PH and Moisture	Included	Included	Included	Included			
Remediation if Applicable	Included	Included	Included	Included			
Resilient Flooring and Rubber Base							
Finish Schedule A-612, F2-Linoleum Tile, B1-4" Vinyl Resilient Base	Included	Included	Included	Included			
MFR - Forbo, Marmoleum Composition Tile (MCT) 13"x13", 2mm thk, pattern & color by Architect	Included	Included	Included	Included			
Include all adhesives & sealants	Included	Included	Included	Included			
Heat-welding of seams with color-matched color rods	6,700	6,700	6,700	6,700			
Resilient Base - Rubber, Cove, 4", preformed inside & outside corners	Included	Included	Included	Included			
MRF - Burke/Mercer, Roppe/Pinnacle, Flexco or equal	Included	Included	Included	Included			
F2 at All Classrooms	Included	Included	Included	Included			
B1 at All Classrooms, storage, back of house rooms	Included	Included	Included	Included			
F2 MCT in Elevator Cab (not listed but include)	640	640	640	640			
Include cleaning of floors after installation per specs	Included	Included	Included	Included			
Safety walk and progressive cleanup	2,320	2,320	2,320	2,320			
Include initial maintenance "starter kit" from manufacturer and conducted (1st time) by flooring sub spec 3.08.B	Included	Included	Included	Included			
Include protection of floors after installation per specs	Included	Included	Included	Included			
TOTALS	69,611	74,220	86,547	74,786	0	0	
Recommendation:	Amount						
Reliable Flooring	69,611						

Bid Evaluation Report

Painting

Marshall Classroom Building

Description	Subcontractors				Job Number	Date Printed	Valley Painting
	Vanguard	Borbon Inc	Triumph Painting	Prime Painting			
Base Bid	53,100	102,000	155,800	185,000	0	0	
Spec #: 07 9200 - Joint Sealants	Included	Included	Included	Included			
Spec #: 09 9000 - Paints and Coatings	Included	Included	Included	Included			
Furnished, Installed, FOB Jobsite, Tax Included	Included	Included	Included	Included			
Plans and Specs Dated: 1/28/2016 & 10/4/2016	Included	Included	Included	Included			
Acknowledgment of RFI's 1-75 dated 6.5.17	Included	Included	Included	Included			
Bid Good for 60 Days	Included	Included	90 Days	Included			
Prevailing Wage	Included	Included	Included	Included			
Prequalified per Oxnard School District Standards	N/A	N/A	N/A	N/A			
Attachment C Acknowledgement	N/A	N/A	N/A	N/A			
Painting and Coating							
BOD - Dunn Edwards or Equal	Included	Included	Included	Included			
Colors TBD	Included	Included	Included	Included			
Finish Schedule A-612:	Included	Included	Included	Included			
F1-Sealed Concrete	w/ waterproofing	w/ waterproofing	w/ waterproofing	w/ waterproofing			
P1-Interior Semi-Gloss Paint	Included	Included	Included	Included			
P2-Interior Gloss Paint	Included	Included	Included	Included			
P3-Clear Sealant	Included	Included	Included	Included			
(3) Top Coats and (1) Coat Primer	Included	Included	Included	Included			
Exterior Plaster Walls & Soffits - 4 coats	Included	Included	Included	Included			
Interior Walls, Soffits and Ceilings, 4 coats	Included	Included	Included	Included			
Exterior & Interior HM Door Frames, 3 coats	Included	Included	Included	Included			
Exterior & Interior HM Doors, 3 coats	Included	Included	Included	Included			
Exterior & Interior Wood Doors, 4 coats	Included	Included	Included	Included			
All Exposed Steel to be Primed with Zinc Coating to Receive Paint (RFI #38)	Included	Included	Included	Included			
Paint Steel Stair Pans, Columns, Stringers, Guardrails and Handrails (RFI #38)	Included	Included	Included	Included			
All Exposed Metal on Roof to be Galvanized per Spec, No Paint Finish (RFI #47)	Included	Included	Included	Included			
Etching galvanized guardrails, handrails & stairs prior to painting	Included	Included	Included	Included			
Insulated and Exposed Pipes, Ducts, Conduit, Hangers, Brackets, Collars and Supports, Mechanical and Electrical Equipment	Included	Included	Included	Included			
Shop-Primed Items	Included	Included	Included	Included			
High Performance Coating at Ext. Hand and Guardrails	Not Included	Not Included	Not Included	Not Included			
Exterior Stairs Shop Primed and Painted	Included	Included	Included	Included			
HSS Steel at Ext. exposed Columns & Beams	Included	Included	Included	Included			
Cleanup of all your work	Included	Included	Included	Included			
Touch-Up Painting Allowance	5,092	5,092	5,092	5,092			

Bid Evaluation Report

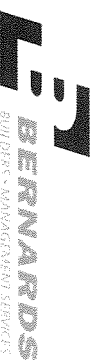

Painting

Marshall Classroom Building

Subcontractors

Description	Subcontractors				Job Number	1641
	Vanguard	Borbon Inc	Triumph Painting	Prime Painting	Date Printed	6/7/2017
Joint Sealant Work Allowance	2,500	2,500	2,500	2,500	7/27/2017	7/27/2017
Hedge	26,800					
ARC:1	2,000	2,000	2,000	2,000		
ARC:4	10,700	11,000	11,000	11,000		
ARC:5	3,000	3,000	3,000	3,000		
ARC:17	(1,000)	(1,000)	(1,000)	(1,000)		
TOTALS	102,192	124,592	178,392	207,592	0	0
Recommendation:	Amount					
Vanguard	102,192					

Bid Evaluation Report

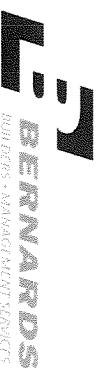

Building Specialties

Marshall Classroom Building

Job Number **1641**
 Bid Date **6/7/2017**
 Date Printed **7/27/2017**
 Bids Received

Div	Description	Amount	Recommended Subcontractor	Bids Received
10 44 00	Fire Extinguishers & Specialties	3,045	BL Wilcox (\$3,045 Supplier)	3
	See sheet A-111 & A-112 for locations of FEC	Included	Inland Empire (\$5,300)	
	1st fl Keynote 10.51 - Fire Extinguisher Cabinet	Included	John Pence (\$4,800)	
	Semi-Recessed, see 6&7/A-530			
	2nd fl Keynote 10.55 - Fire Extinguisher Cabinet	Included		
	Semi-Recessed, see 6&7/A-530			
	1st Fl (8 ea)	Included		
	2nd Fl (1 ea)	Included		
	Provide rated cabinet at rated wall per note on 7/A-530	Included		
	Semi Recessed FEC Max. Projection 4" (RFI #32)			
10 50 50	Lockers	46,600	Inland Empire	1
	Added Spec Section in RFI #9 - Section 10505 dated 5/23/2017	Included		
	See Accessible Locker Calculations on sheet A-411, total of 8	Included		
	MFR - DeBourgh Manufacturing Co. or equal	Included		
	Interior Elevations A-224, see Keynotes	Included		
	12.10 - 12"x12" triple stack locker, see 13/A-530	Included		
	12.13 - Accessible locker, see 13/A-530	Included		
	12.31 - 20"x48" Accessible Locker room bench (handwritten on bottom of keynotes legend)	Included		
	1-Tier Lockers per detail 13/A-530 - None shown	Included		
	2-Tier Lockers per detail 13/A-530 - None shown	Included		
	3-Tier Lockers per 13/A-530	Included		
	At Boys Changing Room - 1/A-411, total of 32, 3-tier	Included		
	Accessible at Boys Changing Room - 1/A-411, total of 1 ea	Included		
	At Girls Changing Room - 1/A-411, total of 32, 3-tier	Included		
	Accessible at Girls Changing Room - 1/A-411, total of 1 ea	Included		
	Include Locker base at stud wall installation per 15/A-530	Included		
	Coordinate blocking & backing w/ Framer	Included		
	At concrete slab use anchor bolts per detail 3/8" dia 3" embedment	Included		
	6" Upturned C/P concrete base w/ tooled radius at lockers - 14 & 15/A-530	w/ Concrete		

Bid Evaluation Report



Building Specialties

Marshall Classroom Building

Job Number	1641
Bid Date	6/7/2017
Date Printed	7/27/2017

Div	Description	Amount	Recommended Subcontractor	Bids Received	
N/A	Misc Site Furnishings	0	Bernards		
	None Noted				
N/A	Misc Equipment (TV's)	6,000	Bernards		
	TV Wall Brackets - 1/A-531	Included			
	MFR not listed, size is 2'-5"X2'	Included			
	Furnished	by District			
	Installed	Included			
	Coordinate blocking & backing w/ framing sub	Included			
	TV's in Classrooms	by District			
	60" Flat Screen by District	by District			
	Final hook-up, connection to Teachers computer	by District			
	Total	55,645			

Bid Evaluation Report



Visual Display Boards

Marshall Classroom Building

Subcontractors

Job Number 1641
 Bid Date 6/7/2017
 Date Printed 7/27/2017

Description	ABC School Equipment		Nelson Adams Naco Inc.		0			
	Included	275,308	Included	208,582				
Base Bid		275,308		208,582				
Spec #: 101101	Included		Included		0			
Spec #:								
Furnished, Installed, FOB Jobsite, Tax Included		Included		Included				
Plans and Specs Dated: 1/28/2016 & 10/4/2016		Included		Included				
Acknowledgment of RFT's 1-75 dated 6.5.17		Included		Included				
Bid Good for 60 Days		60 Days		Included				
Prevailing Wage		Included		Included				
Pregualified per Oxnard School District Standards		N/A		N/A				
Attachment C Acknowledgement		N/A		N/A				
Visual Display Boards								
Finish Schedule A-612:		Included		Included				
W4 - Marker Board Panel over gypsum board		Included		Included				
Interior Elevations sheets A-220 to A-223		Included		Included				
Keynote 10.52-Markerboard Surface from floor to ceiling, Standard panel size 5'x10'		Included		Included				
Keynote 12.26 - 3'-2"x10' Sliding Marker Board, see 10/A-530		Included		Included				
Keynote 12.27 - (2) 2'-8"x10' Sliding Marker Boards, see 10/A-530		Included		Included				
MFR - MooreCo, Claridge or Polyvision or Equal		Platinum Visual		Nelson Adams Naco				
There is a Marker Board Sliding Door Schedule listing all the rooms to receive them on A-610		Included		Included				
Horizontal Sliding Unit Wall System Assembly per 10/A-530		Included		Included				
Furnished AND Installed		Included		Included				
First Floor Classrooms - total of 19 each		Included		Included				
Second Floor Classrooms - total of 23 each		Included		Included				
ARC.4		(60,500)		(60,223)				
TOTALS		214,808		148,359	0	0	0	0
Recommendation:		Amount						
Nelson Adams Naco Inc.		148,359						

Bid Evaluation Report



Signage

Marshall Classroom Building

Subcontractors

Job Number **1641**
 Bid Date **6/7/2017**
 Date Printed **7/27/2017**

Description	AGS	Subcontractors			Braille Signs, INC	Job Number	Bid Date	Date Printed
		John Pence Bldg Spec.	CA Signs					
Base Bid	6,150	10,130	11,471	15,302				
Spec #: 10 1400 - Signage	Included	Included	Included	Included				0
Spec #:								0
Furnished, Installed, FOB Jobsite, Tax Included	Included	Included	Included	Included				
Plans and Specs Dated: 1/28/2016 & 10/4/2016	Included	Included	Included	Included				
Acknowledgment of RFIs 1-75 dated 6.5.17	Included	Included	Included	Included				
Bid Good for 60 Days	Included	Included	Included	Included				
Prevailing Wage	Included	Included	Included	Included				
Prequalified per Oxnard School District Standards	N/A	N/A	N/A	N/A				
Attachment C Acknowledgement	N/A	N/A	N/A	N/A				
Signage	Included	Included	Included	Included				
Signage at Each Bldg per Floor Plans and Elevations	Included	Included	Included	Included				
Signage & Fire Extinguisher Plans - G-006	Included	Included	Included	Included				
Signage Details sheet - A-550	Included	Included	Included	Included				
Room Signs - 1/A-550	Included	Included	Included	Included				
Toilet room door signage - 3/A-550	Included	Included	Included	Included				
Fire Riser door signage - 5/A-550	200	Included	Included	Included				
Exit Signs - 6,7,8/A-550	Included	Included	Included	Included				
Typical Classroom I.S.A signage - 9/A-550	Included	Included	Included	Included				
Restroom Signs - Girls, Boys, Unisex, Staff - Wall & Door signage 3,11,13,14/A-550	Included	Included	Included	Included				
Fire Alarm Panel Control - 12/A550	Included	Included	Included	Included				
Electrical & Not an exit signage 15/A-550	Included	Included	Included	Included				
Maximum occupancy signage - 16/A550	Included	Included	Included	Included				
Stenciling on Rated Walls Signage - 19/A-550	w/ Drywall	w/ Drywall	w/ Drywall	w/ Drywall				
Warning sign - 20/A-550	300	Included	Included	Included				
Fire Extinguisher Signage - 6/A-530, G-006 (17 ea)	2,975	Included	Included	Included				
Assistive Listening Signage	250	Included	Included	Included				
ADA Signage	Included	Included	Included	Included				
Ext. Aluminum Letters, or Painted Bldg # (No Callouts on Elevations)	750	750	750	750				
See Spec Section for several other signs as required	Included	Included	Included	Included				
Site Signage at Fire Lane shown on Site Plan A-101	w/ Striping	w/ Striping	w/ Striping	w/ Striping				
Site Signage at Re-Striped existing parking lot shown on A-102, 104, 105	w/ Striping	w/ Striping	w/ Striping	w/ Striping				
Temporary project signage	2,000	2,000	2,000	2,000				
TOTALS	12,625	12,880	17,196	18,302				0
Recommendation:	Amount							0
AGS	12,625							

Bid Evaluation Report



Toilet Compartments & Accessories

Marshall Classroom Building

Subcontractors

Description	Subcontractors				Job Number	Bid Date	Date Printed
	Inland Empire Arch	YTI Enterprises	John Pence Bldg Spec.	Stumbaugh			
Base Bid	31,400	23,200	30,700	34,192	1641	6/7/2017	7/27/2017
Spec #: 10 2113.17 - Phenolic-Core Shower & Dressing Compartments	Included	Included	Included	Included			
Spec #: 10 2800 - Toilet Accessories	Included	Included	Included	Included			
Furnished, Installed, FOB Jobsite, Tax Included	Included	Included	Included	Included			
Plans and Specs Dated: 1/28/2016 & 10/4/2016	Included	Included	Included	Included			
Acknowledgment of RFIs 1-75 dated 6.5.17	Included	Included	Included	Included			
Bid Good for 60 Days	30 Days	Included	Included	Included			
Prevailing Wage	Included	Included	Included	Included			
Prequalified per Oxnard School District Standards	N/A	N/A	N/A	N/A			
Attachment C Acknowledgement	N/A	N/A	N/A	N/A			
Toilet Compartments	Included	Included	Included	Included			
Solid Phenolic MFR by Formica, Trespa, Pionite ore equal	Accutec	Included	Included	Included			
Galaxy hardware, Series 8033	Included	Included	Included	Included			
Fire Rated Class B for ASTM E84	Included	Included	Included	Included			
Overhead braced	Included	Included	Included	Included			
Accessible compartments	Included	Included	Included	Included			
Standard compartments	Included	Included	Included	Included			
Urinal Screens	Included	Included	Included	Included			
Vestibule Screens	Included	Included	Included	Included			
No colors selected, include standard color palette in your bid	Formica Sparkle	Formica or Wilsonart	Black	Standard Color			
Toilet Accessories	Included	Included	Included	Included			
MFR - Bobrick or approved equal	Included	Included	Included	Included			
Interior Elevations A-224, see Keynotes	Included	Included	Included	Included			
10.03 - Tactile room name & number signage 1/A-550	w/ Signage	w/ Signage	w/ Signage	w/ Signage			
10.03 - Toilet room door signage 3/A-550	w/ Signage	w/ Signage	w/ Signage	w/ Signage			
10.32 - Paper towel dispenser & Waste receptacle 1/A-535	Included	Included	Included	Included			
10.33 - Surface mounted soap dispenser 1/A-5353, B-2111	Included	Included	Included	Included			
10.34 - Multi-roll toilet tissue dispenser, semi recessed 1/A-5353, B-3888	Included	Included	Included	Included			
10.36 - Grab bar - 1, 8 & 10/A-5353, B-6806 series, length per drawing	Included	Included	Included	Included			
10.37 - Seat cover dispenser 1/A-5353, B-221	Included	Included	Included	Included			
10.39 - Mirror 18"x30" 1/A-5353, B-292	Included	Included	Included	Included			
10.41 - Accessible side toilet stall 11/A-5353	Included	Included	Included	Included			
Janitor Closet Accessories	Included	Included	Included	Included			

Bid Evaluation Report

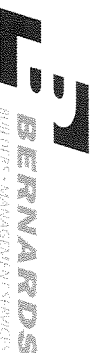

Toilet Compartments & Accessories

Marshall Classroom Building

Subcontractors

Job Number 1641
 Bid Date 6/7/2017
 Date Printed 7/27/2017

Description	Subcontractors				Amount
	Inland Empire Arch	YTI Enterprises	John Pence Bldg Spec.	Stumbaugh	
Mop & Broom Holder (4 Holders) B-223 x 36"	Included	Included	Included	Included	
Not Keynoted, but listed in Spec Section:					
Hand Dryer, World Dryer Model XRA	4,200	4,200	4,200	Included	
Sanitary Napkin Disposal, Recessed B-353 or Partition Mounted B-354	Included	4,800	Included	Included	
Sanitary Napkin Dispenser, Recessed B-3706 25	1,000	1,000	1,000	1,000	
Keys at locked dispensing units, keyed alike	Included	Included	Included	Included	
Other Potential Items:					
Backpack Hooks in Rooms	Excluded	Excluded	Excluded	Excluded	
ARC.14	(4,200)	(4,200)	(4,200)	(4,200)	
TOTALS	32,400	29,000	31,700	30,992	0
Recommendation:					
YTI Enterprises	Amount 29,000				

Bid Evaluation Report

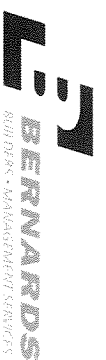

Window Coverings

Marshall Classroom Building

Subcontractors

Description	Subcontractors				Job Number Bid Date	Date Printed Shevard & Son & Sons
	A1 Quality Blinds	Digital Decora	Contract Décor	Diversified Window		
Base Bid	10,000	15,440	16,340	21,248	1641	6/7/2017
Spec #: 12 2413 - Roller Window Shades						7/27/2017
Furnished, Installed, FOB Jobsite, Tax Included	Included	Included	Included	Included	Included	
Plans and Specs Dated: 1/28/2016 & 10/4/2016	Included	Included	Included	Included	Included	
Acknowledgment of RFIs 1-75 dated 6.5.17	Included	Included	Included	Included	Included	
Bid Good for 60 Days	90 Days	Included	90 Days	90 Days	90 Days	
Prevailing Wage	Included	Included	Included	Included	Included	
Pregualified per Oxnard School District Standards	N/A	N/A	N/A	N/A	N/A	
Attachment C Acknowledgement	N/A	N/A	N/A	N/A	N/A	
Window Coverings	Included	Included	Included	Included	Included	
MFR - Levelor, HD, Spring	Included	Included	Included	Included	Included	
New Classroom Building	Included	Included	Included	Included	Included	
All Windows Interior and Exterior	Included	Included	Included	Included	Included	
Motor Operated (Where Shown)	Excluded	Excluded	Excluded	Excluded	Excluded	
MFR - ElectroShade by Mechoshade Systems or approved equal	Excluded	Excluded	Excluded	Excluded	Excluded	
Manual Operated at all windows	Included	Included	Included	Included	Included	
MFR - Mechno/5 by Mechoshade Systems or approved equal	Hunter Douglass	Lutron Contract	FlexShades	Included	Included	
Provide a complete operated system including fabric, mounting spline, end caps, fascia, filters, side channels, center channels, anchors and fasteners	Included	Included	Included	Included	Included	
Fabric "AV Blackout shade my Mechoshade or equal	Included	Included	Included	Included	Included	
TOTALS	10,000	15,440	16,340	21,248	27,860	0
Recommendation:	Amount					
A1 Quality Blinds	10,000					
Alternates						
RFI #25						
Alt #1: Manual Roller Shades at Larger Sectional Doors at Classrooms	9,000	12,628	20,820	Excluded	20,820	
Alt #2: ADD for Motorized Roller Shades at Larger Sectional Doors at Classrooms	13,500	37,552	41,930	Excluded	41,930	

Bid Evaluation Report

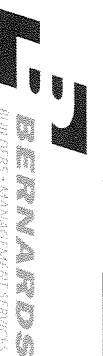

Final Cleaning

Marshall Classroom Building

Subcontractors

Description	Subcontractors			Job Number	1641
	AAA Express Janitorial	All-Pro Bidg Maintenance	Commercial Const Cleaning	Bid Date	6/7/2017
				Date Printed	7/27/2017
Base Bid	2,700	28,760	22,550		
Spec #: N/A	N/A	N/A	N/A		
Furnished, Installed, FOB jobsite, Tax Included	Included	Included	Included		
Plans and Specs Dated: 1/28/2016 & 10/4/2016	Included	Included	Included		
Acknowledgment of RFIs 1-75 dated 6.5.17	Included	Included	Included		
Bid Good for 60 Days	Included	Included	Included		
Prevailing Wage	Included	Included	Included		
Prequalified per Oxnard School District Standards	Included	N/A	N/A		
Attachment C Acknowledgement	Included	N/A	N/A		
Final Construction Cleaning					
Provide all safety equipment, hard hats, gloves, eye protection & vest	Included	Included	Included		
Include all cleaning tools, ladders, mops, brooms, towels, etc.	Included	Included	Included		
Clean elevator, inside & out	500	Included	Included		
Clean interior windows & mullions	Included	Included	Included		
Clean exterior windows	3,500	Included	Included		
Clean all cabinets, counter & millwork	Included	Included	Included		
Clean inside cabinets & drawers, shelves, bookcases	1,500	Included	Included		
Clean all door frames, hardware & kick-plates	Included	Included	Included		
Wipe clean baseboards	Included	Included	Included		
Wipe clean lights & T-bar ceiling (as required)	Included	Included	Included		
Vacuum all carpeted areas	Included	Included	Included		
Clean all air return grills	Included	Included	Included		
Clean all items attached to walls-FEC, MEP devices, signage marker bds, etc.	1,500	Included	Included		
Wipe, clean mech & elec rms equip, ductwork, conduit & piping	1,500	Included	Included		
Clean Boy's & Girl's restrooms & locker rooms	Included	Included	Included		
Clean plumbing fixtures, toilet part, sinks, mirrors, tops, toilets, lockers, etc.	2,500	Included	Included		
Clean tile floors & walls	2,500	Included	Included		
Sweep & mop all floors	Included	Included	Included		
Wax, 3-coat, all VCT floors	2,500	Included	Included		
Sweep & mop all exterior walkways, corridors, stairways & gurradrails	2,500	Included	Included		
Sweep & power wash ext bldg walks, sidewalk & hardscape	3,500	Included	3,500		

Bid Evaluation Report

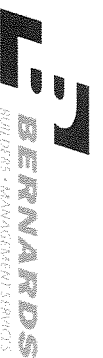

Final Cleaning

Marshall Classroom Building

Subcontractors

Description	AAA Express Janitorial	All-Pro Bldg Maintenance	Commercial Const. Cleaning	Job Number	1641
					Bid Date
				Date Printed	7/27/2017
Prevailing Wage rates requirements	5,000	Included	Included		
T&M rate per employee			\$79.80/hr		
TOTALS	29,700	28,760	26,050	0	0
Recommendation:		Amount			
Commercial Const Cleaning		26,050			

Bid Evaluation Report

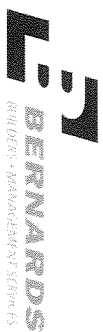

Elevators

Marshall Classroom Building

Subcontractors

Job Number **1641**
 Bid Date **6/7/2017**
 Date Printed **7/27/2017**

Description	Kone, Inc.	Republic Elevator				
			Amount			
Base Bid	195,850	ALT: \$89,860				
Spec #: 14 2123 - Machine-Room-Less Electric Traction Passenger Elevators	Included	No Use Hydro				
Bond Rate	Bond at	Bond at				
Furnished, Installed, FOB Jobsite, Tax Included	Included	Included				
Plans and Specs Dated: 1/28/2016 & 10/4/2016	Included	Included				
Acknowledgment of RFIs 1-75 dated 6.5.17	Included	Included				
Bid Good for 60 Days	30 Days	60 days				
Prevailing Wage	Included	Included				
Prequalified per Oxnard School District Standards	N/A	N/A				
Attachment C Acknowledgement	N/A	N/A				
Elevators						
Deferred Approval - Elevator Guide Rails, G-001	Included	Included				
MFR, BOD - Kone EcoSpace Gearless Traction Elevator	Included	Twin Jack, Holeless				
Hoist Beam, Guide Rails per specs	w/ Steel	w/ Steel				
Pit ladder 13/A-561, notes states by Elev Mfr	w/ Steel	w/ Steel				
Continuous plate PL 3/16"x3" cont across hoistway 5&7/A-561	w/ Steel	w/ Steel				
Bldg I - New Classroom Building	Included	Included				
Elevator No. 1: 3500#, 150ft/min, 2 Stops, 2 Openings per Specs	Included	Included				
Includes all info for Elevator Details shown on sheet A-561	Included	Included				
Cab Interior Finishes - brushed SS at walls, front & doors w/ alum tube rail, ceiling translucent panels, alum threshold, floor (by others)	Included	Included				
Metalworks Linear Faceted/Curved Ceiling system 8" panel per Note 9.03/G-006, see det 4/A-541 (no sheet A-541 provided)	Exclude/Qualify	Exclude/Qualify				
Make Connection Between Fire Alarm Relay and Elevator Controller	Included	Included				
Elevator Hostway Scaffolding	Included	Included				
Hoisting	Included	Included				
Textura invoice system	360	360				
ARC.10	(196,210)	89,860				
TOTALS	0	90,220	0	0	0	0
Recommendation:	Amount					
Republic Elevator	90,220					

Bid Evaluation Report

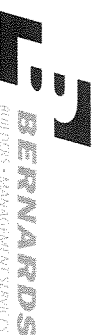

Fire Sprinklers

Marshall Classroom Building

Job Number 1641
 Bid Date 6/7/2017
 Date Printed 7/27/2017

Subcontractors

Description	Subcontractors		
	Apex Fire Protection	J.G. Tate Fire Protection	Superior Fire
Base Bid	276,600	123,456	126,266
Spec # : 21 1000 - Fire Protection	Included	Included	Included
License Designation C-16, Fire Protection Contractor	Included	Included	Included
Furnished, Installed, FOB Jobsite, Tax Included	Included	Included	Included
Plans and Specs Dated: 1/28/2016 & 10/4/2016	Included	Included	Included
Acknowledgment of RFIs 1-75 dated 6.5.17	Included	Included	Included
Bid Good for 60 Days	60 Days	30 Days	30 days
Prevailing Wage	Included	Included	Included
Prequalified per Oxnard School District Standards	No	Yes	Yes
Attachment C Acknowledgement	Included	Included	Included
Furnish & Install Fire Sprinkler System	Included	Included	Included
Building 1, Classroom Building per FP sheets - FP-001 to 005	Included	Included	Included
<i>Manufacturer - Tyco</i>	Included	Included	Included
Complete Wet Pipe Automatic Sprinkler System	Included	Included	Included
UL Approved Black Steel Piping, SCH 40 w/ Cast or Ductile Iron Screwed Fittings - 2" and Smaller	Included	Included	Included
UL Approved Black Steel Piping, SCH 40 w/ Rolled Grooved Ends, Grooved Fittings and Mechanical or Welded Outlets - 2.5" and Larger	Included	Included	Included
Complies with NFPA 13, 2013 ED., DSA, and Local AHJ Requirements	Included	Included	Included
POC from 6" AFF, 4x3 Flexible GRC	Included	Included	Included
3" Fire Riser at Bldg - 1/FP-002	Included	Included	Included
Connect 6" Underground Fire Department Connection	w/ Site Utilities	w/ Site Utilities	w/ Site Utilities
4" Double Detector Check Valve Backflow Preventer (1/FP-02)	w/ Site Utilities	w/ Site Utilities	w/ Site Utilities
Standard Upright, Pendant, Sidewall Sprinklers	Included	Included	Included
Concealed Heads in Finished Ceilings w/ Cover Plate	Included	Included	Included
Flush Sidewall Head in Soffits	Included	Included	Included
Brass or White Finish	Included	Included	Included
All Underground Piping as Required	w/ Site Utilities	w/ Site Utilities	w/ Site Utilities
Piping Distribution (Risers, Mains & Branch Lines)	Included	Included	Included
Upright Sprinkler Deflectors as Shown	Included	Included	Included
Provide Head Guards as Required	Included	Included	Included
Head Box w/ Spare Heads and Wrenches	Included	Included	Included
Install Ceiling Tiles w/ Sprinkler Heads in Panels Where Required (FP-03)	Included	Included	Included

Bid Evaluation Report



Fire Sprinklers

Marshall Classroom Building

Subcontractors

Job Number **1641**
 Bid Date **6/7/2017**
 Date Printed **7/27/2017**

Description	Subcontractors			TOTALS	RECOMMENDATION
	Apex Fire Protection	J.G. Tate Fire Protection	Superior Fire		
Install sprinklers in elevator shaft and elevator equipment, not shown	2,500	2,500	2,500		
All Seismic Bracing, Hangers, Embeds as Required	Included	Included	Included		
Sleeves as Required	Included	Included	Included		
Floor Blockouts, Coring, Saw Cutting as Required	Included	Included	Included		
All Gauges, Valves, Flow and Tamper Switches	Included	Included	Included		
Valve Seals, Tags, Safety Markers, and Charts	Included	Included	Included		
Electric Bell	Included	Included	Included		
Sound and Vibration Control	Included	10,000	Included		
Furnish Access Panels as Required	Included	Included	1,250		
Excavation and Backfill as Required	w/ Site Utilities	w/ Site Utilities	w/ Site Utilities		
Fire Caulking / Sleeves / Firestopping	Included	Included	1,250		
Permits / Plan Check / Inspections / Testing / Fees	1,000	1,000	1,000		
Hydrostatic Testing at 200 PSI for (2) Hours	Included	Included	Included		
Calculations / Engineered Plans / Shop Drawings	Included	Included	2,500		
BIM Coordination	5,000	5,000	5,000		
As-Builts and Record Documents	Included	Included	Included		
Hoisting of Own Material as Required	Included	Included	Included		
Schedule and Pay for State and Local Inspections	1,500	1,500	1,500		
TOTALS	286,600	143,456	151,266	0	0
Recommendation:	Amount				
J.G. Tate Fire Protection	143,456				

Bid Evaluation Report



Plumbing

Marshall Classroom Building

Subcontractors

Description	City Commercial	HPS Mechanical	Moe	Precision Plumbing-Mechanical	Job Number		
					Suttles Plumbing	1641	
						Bid Date	6/7/2017
						Date Printed	7/27/2017
Base Bid	315,100	349,530	335,765	416,610	412,000		
Spec #: 22 0500 - Basic Materials and Methods	Included	Included	Included	Included	Included		
Spec #: 22 0553 - Identification	Included	Included	Included	Included	Included		
Spec #: 22 0700 - Insulation	Included	Included	Included	Included	Included		
Spec #: 22 0800 - Equipment and Systems Tests	Included	Included	Included	Included	Included		
Spec #: 22 1100 - Domestic and Industrial Water Systems	Included	Included	Included	Included	Included		
Spec #: 22 1300 - Drainage System	Included	Included	Included	Included	Included		
Spec #: 22 4000 - Plumbing Fixtures	Included	Included	Included	Included	Included		
Furnished, Installed, FOB Jobsite, Tax Included	Included	Included	Included	Included	Included		
Plans and Specs Dated: 1/28/2016 & 10/4/2016	Included	Included	Included	Included	Included		
Acknowledgment of RFI's 1-75 dated 6.5.17	Included	Included	Included	Included	Included		
Bid Good for 60 Days	30 Days	30 Days	60 Days	60 Days	90 Days		
Prevailing Wage	Included	Included	Included	Included	Included		
Prequalified per Oxnard School District Standards	Yes	Yes	No	Yes	Yes		
Attachment C Acknowledgement	Included	Included	Included	Included	Included		
Furnish & Install All Plumbing Fixtures w/ Associated Connections	Included	Included	Included	Included	Included		
Plumbing Fixtures	Included	Included	Included	Included	Included		
Water Closet, Floor-Mounted ADA (WC-1 & WC-2)	Included	Included	Included	Included	Included		
Lavatory w/ Manual Metering Faucet, Wall-Mounted ADA (L-1 & L-2)	Included	Included	Included	Included	Included		
Waterless Urinals (UR-1)	Included	Included	Included	Included	Included		
Classroom Sink w/ Manual Metering Faucet (S-1)	Included	Included	Included	Included	Included		
ADA Hilo Stainless Drinking Fountain (DF-1)	Included	Included	Included	Included	Included		
Service Sinks (SS-1)	Included	Included	Included	Included	Included		
Floor Drains (FD-1)	Included	Included	Included	Included	Included		
Hose Bibbs (HB-1)	Included	Included	Included	Included	Included		
Hose Bibbs on Landscape Drawings (RFI# 10)	2,000	2,000	2,000	2,000	2,000		
Trap Primers (TP-1)	Included	Included	Included	Included	Included		
Roof / Overflow Drains (RD-1 & OD-1)	Included	Included	Included	Included	Included		
Cleanouts	Included	Included	Included	Included	Included		
Gas Shut-Off Valves	Included	Included	Included	Included	Included		
Water Hammer Arrestors	Included	Included	Included	Included	Included		
All Fixtures Meet ADA	Included	Included	Included	Included	Included		
Commercial Grade Toilet Seats	Included	Included	Included	Included	Included		
Special Wrenches for Servicing	250	Included	Included	Included	Included		
Faucet Repair Kits	1,000	Included	Included	1,000	Included		
Furnish & Install All Plumbing Equipment w/ Associated Connections	Included	Included	Included	Included	Included		

Bid Evaluation Report

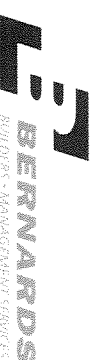

Plumbing

Marshall Classroom Building

Subcontractors

Description	City Commerical	HPS Mechanical	Moe	Precision Plumbing-Mechanical	Suttles Plumbing	
					Job Number	1641
					Bid Date	6/7/2017
					Date Printed	7/27/2017
<i>Manufacturers per P-001</i>	Included	Included	Included	Included	Included	
Tankless Gas Water Heaters (WH-1 & WH-2)	Included	Included	Included	Included	Included	
Circulating Pump (CP-1)	Included	Included	Included	Included	Included	
Expansion Tanks (ET-1)	Included	Included	Included	Included	Included	
Furnish & Install All Plumbing Piping	Included	Included	Included	Included	Included	
Hot and Cold Water Piping	Included	Included	Included	Included	Included	
Copper Type L Lead-Free Piping	Included	Included	Included	Included	Included	
<i>1. Price at all elevations</i> <i>Does not stop any other wire supply</i>	Included	Included	Included	Included	Included	
Waste and Vent Piping	Included	Included	Included	Included	Included	
Cast-Iron, No Hub	Included	Included	Included	Included	Included	
Storm and Roof Drain Piping	Included	Included	Included	Included	Included	
Cast-Iron, No Hub	Included	Included	Included	Included	Included	
Gas Piping	Included	Included	Included	Included	Included	
Schedule 40 Steel	Included	Included	Included	Included	Included	
Condensate Piping, HVAC	Included	Included	Included	Included	Included	
Copper Type M, Lead-Free	Included	Included	Included	Copper Type L	Included	
Connect Sewer, Storm Drain and Domestic Water	Included	Included	Included	Included	Included	
Service 5' Out	Included	Included	Included	Included	Included	
Piping Insulation as Required	Included	Included	Included	Included	Included	
Temporary Water for Construction Use (Meter by Others)	13,400	13,400	13,400	13,400	13,400	
Galvanize Flashings, Roof Jacks, Pipe Collars as Required	Included	Included	Included	Included	Included	
Sheet Metal Flashings for all Plumbing Penetrations	Included	Included	Included	Included	Included	
BIM Coordination	10,000	17,500	10,000	10,000	10,000	
Caulking and Sealants as Required	Included	Included	Included	Included	Included	
Fire Caulking, Sleeves, Fire Stopping as Required	Included	Included	Included	Included	Included	
Drilling, Boring, Cutting, Notching as Required	Included	Included	Included	Included	Included	
Earthquake Shut-Off Valves	Included	Included	Included	Included	Included	
Supports, Anchors, Seismic Bracing as Required	Included	Included	Included	Included	Included	
Safety walk and progressive cleanup	4,642	4,642	4,642	4,642	4,642	
Vibration Isolation	Included	Included	Included	Included	Included	
Access Panels as Required, Furnish Only	Included	Included	Included	Included	Included	
All Related Trenching and Backfill to 90%	Included	Included	Included	Included	Included	
Flush, Chlorinate, Disinfect and Sterilize Domestic Water	Included	Included	Included	Included	Included	
Haul Off Spoils Generated by Own Work	2,470	10,000	2,925	Included	20,000	
Provide and connect water line to construction trailer	3,350	3,350	3,350	3,350	3,350	
Temporary tool/storage bins	1,400	1,400	1,400	1,400	1,400	
Temporary Toilets	2,100	2,100	2,100	2,100	2,100	

Bid Evaluation Report

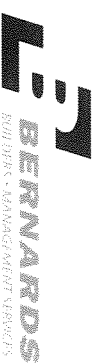

Plumbing

Marshall Classroom Building

Subcontractors

Description	City Commerical	HPS Mechanical	Moe	Precision Plumbing-Mechanical	Suttles Plumbing	Job Number	1641
						Bid Date	6/7/2017
						Date Printed	7/27/2017
Temporary Handwash facilities	2,100	2,100	2,100	2,100	2,100		
ARC:27	(2,500)	(2,500)	(2,500)	(2,500)	(2,500)		
TOTALS	355,312	403,522	375,182	454,102	473,850		0
Recommendation:						Amount	
City Commerical						355,312	

Bid Evaluation Report

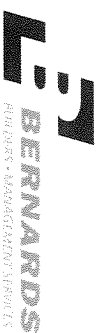

HVAC

Marshall Classroom Building

Subcontractors

Description	Climate Control	J.R. Barto	Sheldon Mechanical	WR Robbins Co.	Job Number
					1641
					Bid Date
					6/7/2017
					Date Printed
					7/27/2017
Base Bid	610,090	544,600	435,800	440,000	
Spec #: 23 0000 - General Provisions	Included	Included	Included	Included	
Spec #: 23 0513 - Electric Motors and Controllers	Included	Included	Included	Included	
Spec #: 23 0548 - Vibration Isolation and Seismic Restraints	Included	Included	Included	Included	
Spec #: 23 2500 - Water Treatment	Quality Exclude	Quality Exclude	Quality Exclude	Quality Exclude	
Spec #: 23 3100 - Air Transmission and Distribution System	Included	Included	Included	Included	
Spec #: 23 8000 - Air Conditioning and Air Handling Management	Included	Included	Included	Included	
Spec #: 23 9000 - Building Management System	Included	Included	Included	Included	
Furnished, Installed, FOB Jobsite, Tax Included	Included	Included	Included	Included	
Plans and Specs Dated: 1/28/2016 & 10/4/2016	Included	Included	Included	Included	
Acknowledgment of RFIs 1-75 dated 6.5.17	Included	Included	Included	Included	
Bid Good for 60 Days	30 Days	30 Days	90 Days	60 Days	
Prevailing Wage	Included	Included	Included	Included	
Prequalified per Oxnard School District Standards	No	Yes	Yes	Yes (Chapman Air Systems, Inc.)	
Attachment C Acknowledgement	Included	Included	Included	Included	
Furnish & Install All HVAC Equipment					
Building Equipment	Included	Included	Included	Included	
Roof-Mounted Package Units w/ Spring Isolators and Curb, AC1-AC12 - Carrier	Included	Included	Included	Included	
Roof-Mounted, Exhaust Fans - Loren Cook	Included	Included	Included	Included	
Ductless Split AC Units - Mitsubishi	Included	Included	Included	Included	
Heating Ventilator Air Units - Reznor	Included	Included	Included	Included	
Factory Curb/ Install	Included	Included	Included	Included	
Furnish & Install All Ductwork and Distribution					
Sheet Metal Lined Round Ducts	Included	Included	Included	Included	
Sheet Metal Rectangular Ducts	Included	Included	Included	Included	
Flexible Round Ducts	Included	Included	Included	Included	
Building Distribution	Included	Included	Included	Included	
Supply, Return and Exhaust Ductwork	Included	Included	Included	Included	
Ceiling Supply/Return/Exhaust Diffusers	Included	Included	Included	Included	
Supply/Return/Exhaust Air Side Grilles	Included	Included	Included	Included	
Side Wall Mounted Transfer Grilles	Included	Included	Included	Included	
Outdoor Exhaust Grilles	Included	Included	Included	Included	
Fire/Smoke Dampers	Included	Included	Included	Included	
90° Elbows at Ceiling Diffusers	Included	Included	Included	Included	
Sound Boots as Required	Included	Included	Included	Included	
Sheet Metal Louvers	Included	Included	3,800	Included	

Bid Evaluation Report



HVAC

Marshall Classroom Building

Subcontractors

Job Number **1641**
 Bid Date **6/7/2017**
 Date Printed **7/27/2017**

Description	Climate Control				Mechanical			
	J.R. Barto	Sheldon	WR Robbins Co.		J.R. Barto	Sheldon	WR Robbins Co.	
Backdraft Dampers at Exhaust as Required	Included	Included	Included	Included	Included	Included	Included	
Condensate Drain Piping - 1/1M505	w/ Plumbing 10,050	w/ Plumbing 10,050	w/ Plumbing 10,050	w/ Plumbing 10,050	w/ Plumbing 10,050	w/ Plumbing 20,000		
22 ga galv hoods at roof ductwork per 4/M-510								
Furnish & Install HVAC Controls	Included	Included	Included	Included	Included	Included	Included	
Energy Management and Building Management Control Systems (DDC)	Included	Included	Included	Included	Included	Included	Included	
MFR - Aleton	Included	Included	Included	Included	Included	Included	Included	
Tie-In Controls w/ Current EMS Already Serving the Existing Campus (RFI #29)	Included	Included	Included	Included	Included	Included	Included	
All Low Voltage Wiring for Own Systems	Included	Included	Included	Included	Included	Included	Included	
All Duct Supports, Seismic Restraints, and Bracing as Required	Included	Included	Included	Included	Included	Included	Included	
HVAC Mounting - M.W. Sausse & Co, Vibrex VIC-EQ w/ Spring Mounts M-521	Included	Included	Included	Included	Included	Included	Included	
All Piping and Duct Insulation as Required	Included	Included	Included	Included	Included	Included	Included	
All Mechanical Piping as Shown on Plans	Included	Included	Included	Included	Included	Included	Included	
Sound and Vibration Control	Included	Included	Included	Included	Included	Included	Included	
Access Panels as Required - Furnish Only	Included	3,500	Included	Included	Included	Included	Included	
All Required Signage and Identification Labels	Included	Included	Included	Included	Included	Included	Included	
Splay Wires for HVAC Registers and Grilles as Required	w/ ACT	w/ ACT	w/ ACT	w/ ACT	w/ ACT	w/ ACT	w/ ACT	
Safety walk and progressive cleanup	6,218	6,218	6,218	6,218	6,218	6,218	6,218	
Construction Filters and Final Filters	Included	Included	Included	Included	Included	Included	Included	
All Sheet Metal Flashings as Required	Included	Included	Included	Included	Included	Included	Included	
Firestopping at Penetrations	Included	2,000	Included	Included	Included	Included	Included	
Testing and Balancing	Included	Included	Included	Included	Included	Included	Included	
Duct Pressure Testing	Quality Exclude	Quality Exclude	Quality Exclude	Quality Exclude	Quality Exclude	Quality Exclude	Quality Exclude	
Hoisting of Own Material as Required	Included	Included	Included	Included	Included	Included	Included	
BIM Coordination	6,700	6,700	6,700	6,700	6,700	6,700	6,700	
ARC.11	(56,000)	(56,000)	(56,000)	(56,000)	(56,000)	(56,000)	(56,000)	
ARC.24	(42,000)	(42,000)	(42,000)	(42,000)	(42,000)	(42,000)	(42,000)	
TOTALS	535,057	475,068	366,968	374,918	366,968	374,918	0	0
Recommendation:	Amount							
Sheldon Mechanical	366,968							

Bid Evaluation Report



Electrical / Low Voltage

Marshall Classroom Building

Subcontractors

Description	Oilfield Electric	Reyes & Sons	Taft Electric	Venco	Job Number	
					Siemens	1641
					Date Printed	6/7/2017
					Date Printed	7/27/2017
Base Bid	1,241,580	1,075,100	989,000	1,020,000	Fire Alarm Only	
Division 26 - Electrical	Included	Included	Included	Included		
Spec #: 26 0126 - Inspection Test and Acceptance	Included	Included	Included	Included		
Spec #: 26 0500 - Common Work Results for Electrical	Included	Included	Included	Included		
Spec #: 26 0513 - Basic Electrical Materials and Methods	Included	Included	Included	Included		
Spec #: 26 0519 - Low-Voltage Wires (600 Volt AC)	Included	Included	Included	Included		
Spec #: 26 0526 - Grounding and Bonding	Included	Included	Included	Included		
Spec #: 26 0533 - Raceways and Boxes Fitting and Supports	Included	Included	Included	Included		
Spec #: 26 0586 - Motors and Drives	Included	Included	Included	Included		
Spec #: 26 0800 - Electrical Systems & Commissioning	Included	Included	Included	Included		
Spec #: 26 0923 - Lighting Control Systems	Included	Included	Included	Included		
Spec #: 26 1000 - Service Entrance	Included	Included	Included	Included		
Spec #: 26 2200 - Low Voltage Transformers	Included	Included	Included	Included		
Spec #: 26 2413 - Switchboards 1000	Included	Included	Included	Included		
Spec #: 26 2416 - Panelboards and Signal Terminal Cabinets	Included	Included	Included	Included		
Spec #: 26 2419 - Motor Control Devices	Included	Included	Included	Included		
Spec #: 26 5000 - Lighting	Included	Included	Included	Included		
Spec #: 26 5200 - Emergency Power Systems	Included	Included	Included	Included		
Spec #: 23 0513 - Electric Motors and Controllers	Included	Included	Included	Included		
Division 27 - Communications	Included	Included	Included	Included		
Spec #: 27 0126 - Test and Acceptance Requirements for Structured Cabling	Included	Included	Included	Included		
Spec #: 27 1013 - Structured Cabling	Included	Included	Included	Included		
Spec #: 27 4113 - Classroom Sound Enhancement System	Included	Included	Included	Included		
Spec #: 27 5116 - Public Address and Intercommunication Systems	Included	Included	Included	Included		
Spec #: 27 5313 - Clock and Program Systems	Included	Included	Included	Included		
Division 28 - Electronic Safety and Security	Included	Included	Included	Included		
Spec #: 28 1600 - Intrusion Detection System	Included	Included	Included	Included		
Spec #: 28 3100 - Fire Detection and Alarm System	Included	Included	Included	Included		
Furnished, Installed, FOB Jobsite, Tax Included	Included	Included	Included	Included		
Plans and Specs Dated: 1/28/2016 & 10/4/2016	Included	Included	Included	Included		
Acknowledgment of RFIs 1-75 dated 6.5.17	Included	Included	Included	Included		
Bid Good for 60 Days	30 days	60 Days	60 Days	30 Days		60 Days

Bid Evaluation Report

Electrical / Low Voltage

Marshall Classroom Building

Subcontractors

Description	Oilfield Electric		Reyes & Sons		Taft Electric		Venco		Siemens	
	Included	Yes	Included	Yes	Included	Yes	Included	Yes	Included	No
Prequalified per Oxnard School District Standards	Included	Yes	Included	Yes	Included	Yes	Included	Yes	Included	Included
Attachment C Acknowledgement	Included		Included		Included		Included		Included	
Furnish & Install Building Electrical										
Main Gear and Panels	Included		Included		Included		Included		Included	
1200A WP Main Switch Board, 480Y/277V, 3 Phase, 4W Panel board ("MP"/E-030)	Included		Included		Included		Included		Included	
500KVA WP Site Transformer w/ Disconnect	Included		Included		Included		Included		Included	
Distribution Boards	Included		Included		Included		Included		Included	
Panel Boards	Included		Included		Included		Included		Included	
Lighting Control Panels and Lighting Control System	Included		Included		Included		Included		Included	
Circuit Breakers	Included		Included		Included		Included		Included	
Transformers	Included		Included		Included		Included		Included	
Ground Bus / Grounding Systems	Included		Included		Included		Included		Included	
Distribution, Conduit and Wiring	Included		Included		Included		Included		Included	
Copper Bussing and Wiring w/ Rigid Conduit	Included		Included		Included		Included		Included	
Feeders (RFI# 26)	Included		Included		Included		Included		Included	
Power Distribution	Included		Included		Included		Included		Included	
Conduits & Raceways	Included		Included		Included		Included		Included	
Lighting Switches, Conduit and Wiring	Included		Included		Included		Included		Included	
Cable Trays	Included		Included		None Shown		None Shown		Included	
Terminal Cabinets & Racks	Included		Included		Included		Included		Included	
Outlet & Junction Boxes, Pull Boxes	Included		Included		Included		Included		Included	
Wiring Devices	Included		Included		Included		Included		Included	
Switches / Disconnects	Included		Included		Included		Included		Included	
Overcurrent Protection	Included		Included		Included		Included		Included	
Connections to Existing Generator	2,500		2,500		2,500		2,500		2,500	
Power to Equipment	Included		Included		Included		Included		Included	
Power to Mechanical & Plumbing Equipment	Included		Included		Included		Included		Included	
Power to Misc. Equipment / Motors / Devices	Included		Included		Included		Included		Included	
Power to Electric Overhead Coiling Doors w/ Low Voltage Wiring (RFI# 62)	Included		Included		Included		Included		Included	
Power to Building Lighting w/ Controls and Panels	Included		Included		Included		Included		Included	
Power for Irrigation Controller (RFI#65)	Included		Included		Included		Included		Included	
Conduit & Back Boxes Only:	Included		Included		Included		Included		Included	
Voice / Data / CATV Systems	Included		Included		Included		Included		Included	
Computer Network Cabling System	Included		Included		Stubs to Ceiling		Included		Included	
Autonomous PA System	Included		Included		Included		Included		Included	
Occupancy / Motion Sensor System	Included		Included		Included		Included		Included	
Energy Management Systems / HVAC Controls	Included		Included		T-Stat Conduit Only		Included		Included	

Bid Evaluation Report

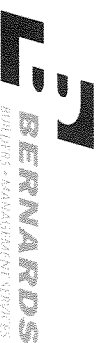

Electrical / Low Voltage

Marshall Classroom Building

Subcontractors

Description	Subcontractors				Siemens
	Oilfield Electric	Reyes & Sons	Taft Electric	Venco	
Other Low Voltage Systems (E-001)	Included	Included	Included	Included	
Temporary Power and Lighting	42,000	42,000	39,000	42,000	
Install, Maintain, Relocate for Construction Offices	Included	Included	Included	Included	
Install, Maintain, Relocate for Building Areas & Site	Included	Included	Included	Included	
Temp Power for Elevator Testing and Build Out	Included	Included	Included	Included	
Temp Power Spider Boxes	Included	Included	Included	Included	
Temp Light Strings	Included	Included	Included	Included	
Conduit and Wire to Jobsite Trailers	Included	Included	Included	Included	
Furnish & Install Building Low Voltage Systems					
Fire Alarm System	See Below	See Below	See Below	See Below	See Below
Complete Addressable Fire Alarm System (E-204 & E-304)	71,131	71,131	Included	71,131	71,131
<i>Manufacturer - Siemens</i>	Siemens Bid	Siemens Bid	Included	Siemens Bid	Included
Per City Fire Dept. Standards	Included	Included	Included	Included	Included
FACP, Annunciator, Devices, Equipment & Conductors	Included	Included	Included	Included	Included
Fire Alarm Equipment Schedule E-020	Included	Included	Included	Included	Included
Fire Alarm Details - E020-022	Included	Included	Included	Included	Included
Elevator System	Connection Only	Connection Only	Connection Only	Connection Only	Connection Only
Horns, Strobes, Pull Stations, Detectors	Included	Included	Included	Included	Included
Smoke Duct Detectors - Furnish Only	Included	Included	Included	Included	Included
Interlock to HVAC Unit Shut-Down, as shown	Included	Included	Included	Included	Included
Complete Plans / Specifications / Calculations	Included	Included	Included	Included	Included
Submittals / Shop Drawings / As-Builts	Included	Included	Included	Included	Included
Permits / Licenses / Fees	Included	Included	Included	Included	Included
Security, Intrusion and Access Control System	24,950	Included	Included	27,500	Included
<i>MFR - Per Specs</i>	Included	Included	Included	Included	Included
Computer, Monitors, and Recording Devices	By Owner	By Owner	By Owner	By Owner	
Complete	Included	Included	Included	Included	
Infrared Motion Detectors	Included	Included	Included	Included	
Interconnection with Door and Gate Hardware as Required	Included	Included	Included	Included	
Interconnection with Overhead Doors as Required	Included	Included	Included	Included	
Interconnection with Elevators as Required	Included	Included	Included	Included	
All Weather-Rated Enclosures	Included	Included	Included	Included	
All Wiring as Required	Included	Included	Included	Included	
Complete Plans / Specifications / Calculations	Included	Included	Included	Included	
Submittals / Shop Drawings / As-Builts	Included	Included	Included	Included	
Permits / Licenses / Fees	Included	Included	Included	Included	
Telecom / Data / CATV (E-203 & E-303)	Included	Included	Included	Included	
Telecom / CATV Back-Bone Cabling	Included	Included	Included	Included	

Bid Evaluation Report

Electrical / Low Voltage

Marshall Classroom Building

Subcontractors

Description	Oilfield Electric	Reyes & Sons	Taft Electric	Venco	Job Number	1641
					Bid Date	6/7/2017
					Date Printed	7/27/2017
					Siemens	
Multi-Mode & Single-Mode Fiber Optic Cable	Included	Included	Included	Included		
CAT 5E Cabling	Included	Included	Included	Included		
Voice Cabling	Included	Included	Included	Included		
Faceplates, Data and Phone Jacks	Included	Included	Included	Included		
Signal Terminal Cabinets	Included	Included	Included	Included		
All Connectors, Hangers, Labels as Required	Included	Included	Included	Included		
All Wiring as Required	Included	Included	Included	Included		
Install and Connect Owner Furnished Rack Mounted Uninterruptible Power Supplies and Ethernet Switches in Equipment Cabinets at Locations with Active Equipment.	Included	Included	Included	Included		
Submittals / Shop Drawings / As-Builts	Included	Included	Included	Included		
Permits / Licenses / Fees	Included	Included	Included	Included		
Classroom Sound Enhancement System (E-203 & E-303)	Included	Included	Included	Included		
<i>Manufacturer - Per Spec (274113, 2.01)</i>	Included	Included	Included	Included		
Infrared Technology - Dome Sensors	Included	Included	Included	Included		
Single and Multiple Input/Output Amplifiers	Included	Included	Included	Included		
Loudspeakers w/ Integral Sealed Back Can	Included	Included	Included	Included		
Wall Mounted Control Panel	Included	Included	Included	Included		
Conductors and Cabling	Included	Included	Included	Included		
Battery Chargers	Included	Included	Included	Included		
Seal all Firewalls Penetrated	Included	Included	Included	Included		
All Equipment Racks Bolted to the Floor	Included	Included	Included	Included		
Submittals / Shop Drawings / As-Builts	Included	Included	Included	Included		
Permits / Licenses / Fees	Included	Included	Included	Included		
PA and Intercommunication System (E-203 & E-303)	Included	Included	Included	Included		
<i>Manufacturer - Per Spec (275116, 2.01)</i>	Included	Included	Included	Included		
System Equipment Racks	By Owner	By Owner	By Owner	By Owner		
Central Card Cage / Shelf Assembly	By Owner	By Owner	By Owner	By Owner		
Intercom System w/ Display Telephone	Included	Included	Included	Included		
Wall Mounted Control Panel & Display Units	Included	Included	Included	Included		
Turners, CD Players, Power Amplifiers, Loudspeakers Etc.	By Owner	By Owner	By Owner	By Owner		
Terminal Blocks and Cabinets	Included	Included	Included	Included		
Conductors and Cabling	Included	Included	Included	Included		
Seal all Firewalls Penetrated	Included	Included	Included	Included		
All Equipment Racks Bolted to the Floor	Included	Included	Included	Included		
Submittals / Shop Drawings / As-Builts	Included	Included	Included	Included		
Permits / Licenses / Fees	Included	Included	Included	Included		
Master Clock System	Included	Included	Included	Included		
<i>Manufacturer - Lathem LTR8-512-M or District Approved</i>	Included	Included	Included	Included		
Power Supplies, Backboxes, Etc.	Included	Included	Included	Included		

Bid Evaluation Report

Electrical / Low Voltage

Marshall Classroom Building

Subcontractors

Description	Oilfield Electric	Reyes & Sons	Taft Electric	Venco	Siemens	Job Number	1641
						Bid Date	6/7/2017
						Date Printed	7/27/2017
All Wall-Mounted Clocks	Included	Included	Included	Included			
Standby Battery System (7 Days)	Included	Included	Included	Included			
All Wiring as Required	Included	Included	Included	Included			
Seal all Firewalls Penetrated	Included	Included	Included	Included			
Furnish & Install Site Electrical	Included	Included	Included	Included			
Safe-Off of Electrical For Removal of Existing Equipment, Conduit and Wiring (2/E-102)	Included	Included	Included	Included			
Removal, Replacement at Existing Site Electrical (E-102)	108,458	108,458	108,458	108,458	125,208	16,750	
Surveying route of new service	Included	Included	Included	Included			
Potholing & line verification of new runs	Included	Included	Included	Included			
Demo area at new transformer/switchgear in parking lot:	Included	Included	Included	Included			
Demo curbs	Included	Included	Included	Included			
Demo Landscape/AC Paving	Included	Included	Included	Included			
AC Paving demo at dropoff	Included	Included	Included	Included			
Sawcut and demo site concrete work entire run of Electrical runs	Included	Included	Included	Included			
Add 50% more site concrete demo to go to a control or expansion joint	Included	Included	Included	Included			
Sawcut and demo AC Paving work entire run of Electrical runs	Included	Included	Included	Included			
Demo at Dirt / Landscape/Shrubs/Irrigation work entire run of Electrical runs	Included	Included	Included	Included			
New work for SCE work (E-101 & E-102)	Included	Included	Included	Included			
New Pads at new SCE transformer - 8'x10' - 1/E-102	Included	Included	Included	Included			
New Pads at new 500kva Transformer - 16'x21' - 1/E-102	Included	Included	Included	Included			
New Curbs (from Demo above)	Included	Included	Included	Included			
Put-Back Balance of Landscape/AC Paving in reworked electrical area at existing parking lot	Included	Included	Included	Included			
AC Paving at trench that crossed the Dropoff drive lane	Included	Included	Included	Included			
Possible Re-Striping	Included	Included	Included	Included			
Reinstall site concrete work entire run of Electrical runs - this appears to be colored concrete	Included	Included	Included	Included			
Reinstall the Added 50% more site concrete demo to go to a control or expansion joint	Included	Included	Included	Included			
Reinstall AC Paving work entire run of Electrical runs	Included	Included	Included	Included			
Reinstall Dirt/Landscape/Shrub/Irrigation work entire run of Electrical runs	Included	Included	Included	Included			

Bid Evaluation Report



Electrical / Low Voltage

Marshall Classroom Building

Subcontractors

Description	Oilfield Electric	Reyes & Sons	Taff Electric	Venco	Job Number	1641
					Bid Date	6/7/2017
					Date Printed	7/27/2017
					Siemens	
Furnish / Install concrete filled steel Bollards with footings	Included	Included	Included	Included		
Dry Utilities - Power	Included	Included	Included	Included		
Secondary Conduit From New On-Site Transformer to New WP Main Switchboard (Wire by SCE) (1/E-102)	Included	Included	Included	Included		
MP-1 - (3) 3" Conduit w/ (3) 350KCM & (1) #2/0 in Each Conduit (RFI# 26)	Included	Included	Included	Included		
MP-2 - (3) 3" Conduit w/ (4) 250KCM & (1) #2/0 in Each Conduit & (2) 4" Conduit for Future Power to New Pullbox to New Building (RFI# 26)	Included	Included	Included	Included		
Power to Existing "MSB" From New 500KVA Transformer	Included	Included	Included	Included		
MP-1A - (6) 3" Conduit w/ (4) 350KCM & (1) 250KCM in Each Conduit (RFI# 26)	Included	Included	Included	Included		
New Intercept Underground Pullbox and Connection to Existing Power for "MSB"	Included	Included	Included	Included		
(4) 350KCM & (1) 250KCM Wiring in Existing "MSB" Conduits	Included	Included	Included	Included		
Stub Out (2) Different Lines of (2) 4" Conduit for Future Power from New Pullbox (E-101)	Included	Included	Included	Included		
Utility Company Primary Switch	w/ SCE	w/ SCE	w/ SCE	w/ SCE		
Utility Company Site Transformer	w/ SCE	w/ SCE	w/ SCE	w/ SCE		
Conductors: by Utility Company	w/ SCE	w/ SCE	w/ SCE	w/ SCE		
Dry Utilities - Low Voltage	Included	Included	Included	Included		
(5) 2" Conduits for Low Voltage Systems (FA, SEC, Clock, PA, Tele and Data) From Existing Building to New Pullbox to New Building (E-101)	Included	Included	Included	Included		
(4) 2" Conduits for Future Low Voltage Stubbed From Existing Building to New Pullbox (E-101)	Included	Included	Included	Included		
Stub Out (2) Different Lines of (4) 2" Conduit for Future Low Voltage from New Pullbox (E-101)	Included	Included	Included	Included		
Underground Power Distribution for Site Lighting and Site Power	Assume Existing	Assume Existing	Assume Existing	Assume Existing		
Power to PIVs, Tamper Switches, Backflows	Included	Included	Included	Included		
Electrical Vaults / Pull Boxes, as required	Included	Included	Included	Included		
Traffic Rated Covers / Frames, as required	Included	Included	Included	Included		
Furnish & Install Lighting						
LED and Fluorescent Lighting as Shown	Included	Included	Included	Included		
Lighting Fixtures per Schedule on E-010	Included	Included	Included	Included		

Bid Evaluation Report

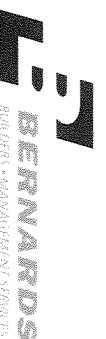

Electrical / Low Voltage

Marshall Classroom Building

Subcontractors

Description	Oilfield Electric	Reyes & Sons	Taft Electric	Venco	Siemens	Job Number	1641
						Bid Date	6/7/2017
						Date Printed	7/27/2017
Lighting Fixtures at New Classroom Building (E-201 & E-301)	Included	Included	Included	Included			
Exit Signs	Included	Included	Included	Included			
LED Lamps	Included	Included	Included	Included			
Non-LED Lamps	Included	Included	Included	Included			
Occupancy Sensors	Included	Included	Included	Included			
Spare Parts as Required (Spec. 265000, 3.03)	Included	Included	Included	Included			
Coordination of Shipping and Installation of Fixtures	Included	Included	Included	Included			
BIM Coordination (1 per Week for 2 Months)	18,425	18,425	16,750	18,425		3,000	
Plywood Backboards	w/ Rough Carp	w/ Rough Carp	w/ Rough Carp	w/ Rough Carp			
Mounting & Anchoring Details - E7.1 & 7.2	Included	Included	Included	Included			
Concrete base at Electrical Equipment 5/E-050	w/ Site Concrete	w/ Site Concrete	w/ Site Concrete	w/ Site Concrete			
Protective Bollards 2/E-050	w/ Misc. Metals	w/ Misc. Metals	w/ Misc. Metals	w/ Misc. Metals			
NEMA Enclosures, where shown	Included	Included	Included	Included			
Flashings at Penetrations	Included	Included	Included	2,000		Included	
Caulkings / Sealants	Included	Included	Included	Included		Included	
Sleeves / Fire Caulking / Firestopping, as required	Included	Included	Included	Included		Included	
Sound and Vibration control	Included	Included	Included	Included		Included	
All Block Outs, Inserts, Coring, Notching, etc.	Included	Included	Included	Included		Included	
Backfill Trenches / Bedding	Included	Included	Included	Included		Included	
Safety walk and progressive cleanup	7,772	7,772	7,772	7,772			
All Required Signage and Identification Labels	Included	Included	Included	Included		Included	
Seismic Bracing to Meet Code	Included	Included	Included	Included		Included	
Access Panels as Required - Furnish Only	Included	5,000	3,000	4,000		1,500	
Haul Off Spoils Generated by Own Work	Included	15,000	15,000	15,000			
Electrical Permits	Included	3,000	No cost	3,000			
Disconnect & reconnect existing PV panels during SCE switch-over	5,000	5,000	5,000	5,000			
Refuse signs not included on lighting fixture schedule	1,000	1,000	1,000	1,000			
ARC.25	(10,000)	(10,000)	(10,000)	(10,000)			
TOTALS	1,512,816	1,344,386	1,177,480	1,317,786		75,631	0
Recommendation:	Amount						
Taft Electric	1,177,480						

Bid Evaluation Report

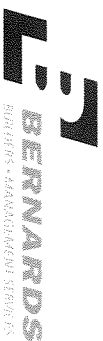

Electrical / Low Voltage

Marshall Classroom Building

Subcontractors

Description	Oilfield Electric	Reyes & Sons	Taft Electric	Venco	Siemens	Job Number	1641
						Bid Date	6/7/2017
						Date Printed	7/27/2017
Alternates							
Add Alternate (RFI#70) - Per Spec I01400 2.07B, Provide Refuse Sign not Indicated on Lighting Fixture Schedule.			\$850/ea				
Add Alternate (RFI #16) - Connect Genset w/ Power Required for Essential Equipment to run During Potential Power Outages such as Site & Parking Lot Lights, Fire Alarm Panel, Security System, and Jobsite/Trailers Related Electrical Requirements.			35,000				

Bid Evaluation Report

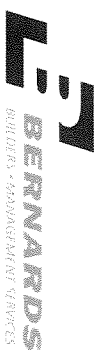

Demo & Earthwork

Marshall Classroom Building

Subcontractors

Job Number **1641**
 Bid Date **6/7/2017**
 Date Printed **7/27/2017**

Description	Standard Demolition	Damar Const.	Leko Const.	Toro Ent.		
Base Bid	See Below	See Below	See Below	See Below		
Spec #: 31 1000 - Site Clearing	Included	Included	Included	Included		
Spec #: 31 2200 - Grading	Included	Included	Included	Included		
Spec #: 31 2316 - Excavation & Fill Paving	Included	Included	Included	Included		
Spec #: 31 2319 - Excavation & Fill Structures	Included	Included	Included	Included		
Spec #: 31 2323 - Excavation & Fill Utilities	Included	Included	Included	Included		
Spec #: 31 2326 - Base Course	Included	Included	Included	Included		
Soil Report: by CTE South dated 7/11/16	Included	Included	Included	Included		
Bond Rate (if required)						
Furnished, Installed, FOB Jobsite, Tax Included	Included	Included	Included	Included		
Plans and Specs Dated: 1/28/2016 & 10/4/2016	Included	Included	Included	Included		
Acknowledgment of RFI's 1-75 dated 6.5.17	Included	Included	Included	Included		
Bid Good for 60 Days	Included	Included	Included	Included		
Prevailing Wage	Included	Included	Included	Included		
Prequalified per Oxnard School District Standards	N/A	N/A	N/A	N/A		
Attachment C Acknowledgement	N/A	N/A	N/A	N/A		
Demolition						
Demolition Plan C-101, at New Building location	35,467	32,985	35,467	35,467	No Bid	
Demolition Plan C-102, at Reworked Existing Parking Lot area	Included	Included	Included	Included	Included	
Demolition Plan C-103, at New Play Area location	Included	Included	Included	Included	Included	
Underground Utility Location, Potholing, Capping or Disconnecting Utilities	5,000	5,000	5,000	5,000		
Removal Notes:	Included	Included	Included	Included		
1 - Remove existing asphalt pavement & base, full depth	Included	Included	Included	Included		
2 - Clear, grub & remove existing turf/planter/exposed subgrade area	Included	Included	Included	Included		
3 - Remove existing shrubs, trees and roots	Included	Included	Included	Included		
4 - Remove existing catch basin	Included	Included	Included	Included		
5 - Remove Play area, including the existing play structure (Per RFI#11)	Included	1,500	Included	Included		
6 - Sawcut existing & remove existing pavement, curb or v-gutter	Included	Included	Included	Included		
7 - Remove existing curb	Included	Included	Included	Included		
8 - Remove existing utilities (identified)	Included	Included	Included	Included		
9 - Sandblast existing striping	Included	Included	Included	Included		
10 - Contractor to rework existing irrigation as needed to allow for new const. Provide shop drawings for approval of revised/reworked irrigation system prior to re-installation	w/ Landscape	w/ Landscape	w/ Landscape	w/ Landscape		
11 - Remove existing concrete V-gutter	Included	Included	Included	Included		
12 - Remove sign in its entirety	Included	Included	Included	Included		
30-39 - Protect-In-Place items as noted	Included	Included	Included	Included		

Bid Evaluation Report



Demo & Earthwork

Marshall Classroom Building

Subcontractors

Description	Standard Demolition	Damar Const.	Leko Const.	Toro Ent.	Job Number	1641
					Bid Date	6/7/2017
					Date Printed	7/27/2017
Demo Mobilizations	1,000	Included	Includes 2 ea	Includes 2 ea		
Add for demo of existing handball court walls & footings	Excluded	Excluded	Excluded	Excluded		
Grading	No Bid	94,720	108,940	96,507		
See General Civil Notes pertaining to your scope - C-001	-----	Included	Included	Included		
Water Meter and Construction Watering for Own Scope	-----	1,000	1,000	1,000		
Erosion Control for your work (none shown on drawings)	-----	2,500	2,500	2,500		
Haul route for your work	-----	Included	Included	Included		
Move-Ins as required	-----	Included	Included	Included		
July '17 Move-On	-----	Included	Included	Included		
Include per Composite Grading Plan C-300,301,302 and Grading Sections C-303-304	-----	Included	Included	Included		
Mass Excavation and Fine Grade Subgrade	-----	Included	Included	Included		
Soils Report: #5.2-Site Preparation, Geotechnical & Grading Notes: C-001	-----	Included	Included	Included		
Temp Soil Stabilization (if required)	-----	Included	Included	Included		
Over-Ex to suitable native soils (varies across site, but generally lie approx 4' below current grades) or minimum 42" below bottom of all footings, whichever depth is greatest	-----	Included	Included	Included		
See Structural detail 15/S-400A, Typical Foundation & Slab Subgrade - excavation to 42" below footing and 60" below finish grade	-----	Included	Included	Included		
Extend 5' from Perimeter Edges	-----	Included	Included	Included		
Onsite existing fill disturbed for agricultural activities and native materials are suitable for use as fill and backfill materials	-----	Included	Included	Included		
Over-Ex at Elevator Pit	-----	Included	Included	Included		
Over-Ex 24" at Site Conditions - AC Paving, Site concrete, Unit Pavers, Play Area surfacing	-----	Included	Included	Included		
Sub-Grade Compaction of 90%	-----	Included	Included	Included		
At PCC Pavers: removal, excavation and recompaction of top 24" to 95%	-----	Included	Included	Included		
New Play Area: C-103, 9/C-702	-----	Included	Included	Included		
Overexcavate & recompact area after demo, ready for perimeter concrete curb (by others)	-----	Included	Included	Included		
Include Type 2 sub-base to 95% compaction - thickness to be 4"	-----	5,000	5,000	5,000		
Geofabric over subbase, per cut sheet from RFI#12 response - provide Alternate Add	-----	Not required	Not required	Not required		
Excavation for mow strips	-----	2,500	Included	Included		

Bid Evaluation Report



Demo & Earthwork

Marshall Classroom Building

Subcontractors

Job Number 1641
 Bid Date 6/7/2017
 Date Printed 7/27/2017

Description	Standard Demolition	Subcontractors				
		Damar Const.	Leko Const.	Toro Ent.		
Fine Grading for Sitework	-----	Included	Included	Included		
Export Spoils Stockpiled by Others	-----	\$XX / CY	\$XX / CY	\$XX / CY		
Concrete Footing Spoils, Structural	-----	8,125	8,125	8,125		
Concrete Footing Spoils, Site	-----	1,250	1,250	1,250		
Site Utilities	-----	2,500	2,500	2,500		
Plumbing, Electrical	-----	2,500	2,500	2,500		
Dust Control during construction		16,884	16,884	16,884		
TOTALS	0	176,464	189,166	176,733	0	0
Recommendation:	Amount					
Damar Const.	176,464					

Bid Evaluation Report

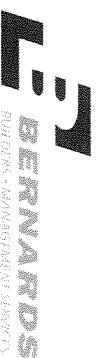

Asphalt Paving & Striping

Marshall Classroom Building

Subcontractors

Description	ABC Resources	Onyx Paving	Toro Ent.	Excel Paving	Job Number	B&M Contractors	
						Berry Engineering	B&M Contractors
Subcontractors					Bid Date	Date Printed	
Base Bid	0	35,440	See below	64,950	37,772	6/7/2017	1641
Spec #: 31 2316 - Excavation & Fill Paving	-----	Included	Included	Included	Included		Included
Spec #: 31 2326 - Base Course	-----	Included	Included	Included	Included		Included
Spec #: 32 0117 - Pavement Repair	-----	Included	Included	Included	Included		Included
Spec #: 32 1216 - Asphalt Paving	-----	Included	Included	Included	Included		Included
Spec #: 32 1236 - Seal for Bituminous Surfacing	Included	Included	Included	Included	Included		Included
Bond Rate (if required)							
Furnished, Installed, FOB Jobsite, Tax Included	Included	Included	Included	Included	Included		Included
Plans and Specs Dated: 1/28/2016 & 10/4/2016	Included	Included	Included	Included	Included		Included
Acknowledgment of RFIs 1-75 dated 6.5.17	Included	Included	Included	Included	Included		Included
Bid Good for 60 Days	Included	Included	Included	Included	Included		Included
Prevailing Wage	Included	Included	Included	Included	Included		Included
Prequalified per Oxnard School District Standards	N/A	N/A	N/A	N/A	N/A		N/A
Attachment C Acknowledgement	N/A	N/A	N/A	N/A	N/A		N/A
AC Paving							
See Legend on C-002:	No Bid	Included	Included	Included	Included		Included
Eastside of New Building - 3" thk AC Surfacing over 7" thk crushed aggregate base (CAB), per 1/C-702	-----	Included	Included	Included	Included		Included
Fire Lane, 4" thk (2" Class C2 & 2" Class B) AC Surfacing over 9" thk crushed aggregate base (CAB), per 1/C-702	-----	Included	15,538	Included	Included		Included
Include the Pavement-to-pavement joint detail, 4/C-702	-----	Included	Included	Included	Included		Included
Existing Parking Lot Rework, C-202	-----	Included	Included	Included	Included		Included
Sawcut and removal of existing paving (C-102)	-----	w/ Demo	Included	w/ Demo	Included		Included
Remove, reinstall base & recompact subgrade if unsuitable per 32.01.17, 3.02.B	-----	w/ Demo	w/ Demo	w/ Demo	w/ Demo		w/ Demo
3" thk AC Surfacing over 7" thk crushed aggregate base (CAB), per 1/C-702	-----	Included	27,966	Included	Included		Included
Redwood Header at Grass	-----	Included	Included	Included	Included		Included
Final 2 coat Seal over new paving per specs	-----	2,850	Included	Included	Included		Included
Clean, Re-Seal, Re-Stripe existing Playground area, not shown	Excluded	Excluded	Excluded	Excluded	Excluded		Excluded
Striping & Signage							
Existing Parking Lot - Striping Plan C-204	9,275	No Bid	No Bid	No Bid	No Bid		No Bid
Sandblast existing striping at existing lot per Demo sheet C-102	Included	8,790	10,820	10,820	10,820		10,820
Installation of new work at Existing Parking Lot: Standard Parking Spaces - 4" thk white lane per Caltrans Std Plan A20B, detail 27B	Included	Included	-----	-----	-----		-----
Stripe Crosshatch Areas	Included	Included	-----	-----	-----		-----

Bid Evaluation Report



Asphalt Paving & Striping

Marshall Classroom Building

Subcontractors

Description	ABC Resources	Onyx Paving	Toro Ent.	Excel Paving	Job Number	1641
					Date Printed	6/7/2017
					Berry Engineering	B&M Contractors
					7/27/2017	
Stripe Arrows	Included	Included	-----	-----	-----	-----
Fire Lane Curbs Red - none shown	Included	Included	-----	-----	-----	-----
Accessible Parking Spaces - see A-104	Included	Included	-----	-----	-----	-----
Concrete Wheel Stops at Accessible parking - 32 13	Included	Included	-----	-----	-----	-----
13, 2.01, C.1-3 & 13/A-105	Included	Included	-----	-----	-----	-----
Precast 6' length x 6" ht doweled into paving per detail	Included	Included	-----	-----	-----	-----
Signage - Accessible sign w/ Posts & footing - 1, 9/A-105	Included	Included	-----	-----	-----	-----
Existing Fire Lane road in front of new Building - FLS Plan G-003	Included	Included	-----	-----	-----	-----
Signage - Fire Access Entrance Signage w/ Post & footing - Sheet Note #5	Included	Included	-----	-----	-----	-----
Signage - New Fire Lane Sign w/ Post & footing - Sheet A-101 & 2/A105 (same as above)	Included	Included	-----	-----	-----	-----
Striping - "Where curb occurs, Paint curb Red to designate Fire Lane" - G-003	Included	Included	-----	-----	-----	-----
Striping - "Fire flush to adjacent surface, paint 'No Parking Fire Lane' w/ Red Lettering" - G-003	Included	Included	-----	-----	-----	-----
Existing Hopscotch, Foursquare, Tetherball adjacent to site RE-Striping - Allowance	1,000	1,000	-----	-----	-----	-----
Existing Main Entry into School - A-101	Included	Included	-----	-----	-----	-----
Signage - New "Tow Away" Sign w/ Post & footing - 7/A-105	Included	500	-----	-----	-----	-----
TOTALS	0	48,580	54,324	75,770	48,592	60,645
Recommendation:	Amount					
Onyx Paving	48,580					

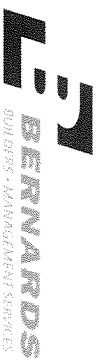

Bid Evaluation Report

Site Concrete

Marshall Classroom Building

Subcontractors

Description	B&M Contractors	Barcelo Concrete	Santa Clarita Concrete	Toro Ent.	Job Number	1641
					Bid Date	6/7/2017
Description	B&M Contractors	Barcelo Concrete	Santa Clarita Concrete	Toro Ent.	Berry	7/27/2017
					Engineering	
Base Bid	176,900	267,864	135,000	See below	145,960	
Spec # : 31 2316 - Excavation & Fill Paving	Included	Included	Included	Included	Included	
Spec # : 31 2319 - Excavation & Fill Structures	Included	Included	Included	Included	Included	
Spec # : 31 2326 - Base Course	Included	Included	Included	Included	Included	
Spec # : 32 1313 - Site Concrete Work	Included	Included	Included	Included	Included	
Bond Rate (if required)		Bond @ 1%	Bond @ 1%	Bond @ 1%	Bond @ 1%	
Furnished, Installed, FOB Jobsite, Tax Included	Included	Included	Included	Included	Included	
Plans and Specs Dated: 1/28/2016 & 10/4/2016	Included	Included	Included	Included	Included	
Acknowledgment of RFIs 1-75 dated 6.5.17	Included	Included	Included	Included	Included	
Bid Good for 60 Days	30 Days	90 days	30 Days	30 Days	30 Days	
Prevailing Wage	Included	Included	Included	Included	Included	
Prequalified per Oxnard School District Standards	N/A	N/A	N/A	N/A	N/A	
Attachment C Acknowledgement	N/A	N/A	N/A	N/A	N/A	
On Site						
Existing Parking Lot Rework, C-202	Included	Included	Included	12,522	Included	
Sawcut and removal of existing site concrete (C-102)	w/ Demo	w/ Demo	w/ Demo	w/ Demo	w/ Demo	
Remove, reinstall base & recompact subgrade per Note 6, Det 3/C-703	w/ Grading	w/ Grading	w/ Grading	w/ Grading	w/ Grading	
Note 12 - Concrete Curb per det 3/C-703	Included	Included	Included	Included	Included	
6" concrete curb w/ (2) #4 bars continuous length of curb	Included	Included	Included	Included	Included	
At New revised Accessible spaces, it is assume use of existing concrete handicap ramps at existing diagonal layout	Qualification	Qualification	Qualification	Qualification	Qualification	
Sandblasting (by demo), Re-Striping (by Striper) will be laid-out to reuse concrete ramps	by Others	by Others	by Others	by Others	by Others	
This subcontractor will install Truncated Domes at existing ramps per A-104 & det 5/A-105, 2 ea 3'x4' min	Excluded	Excluded	Excluded	Excluded	Excluded	
Truncated Domes to be Armor Tile or equal per detail 6/C-703	Excluded	Excluded	Excluded	Excluded	Excluded	
Per SCE Drawings & E sheets:						
Transformer Pad - 2/E-020	Included	10,400	Included	10,400	10,400	
Install concrete-filled steel bollards 2/E-020	Included	2,000	2,000	2,000	2,000	
New Rubber Surfacing at existing playground area adjacent to new building, C-203						
Note 13 - Concrete Curb per det 9/C-702	Included	Included	Included	22,332	Included	
6" wide concrete curb at perimeter of play area	Included	Included	Included	Included	Included	
Includes removal, excavation and recompaction of top 24" to 95%	w/Demo, Grading	w/Demo, Grading	w/Demo, Grading	w/Demo, Grading	w/Demo, Grading	

Bid Evaluation Report



Site Concrete

Marshall Classroom Building

Subcontractors

Description	Subcontractors				Toro Ent.	Job Number 1641
	B&M Contractors	Barcelo Concrete	Santa Clarita Concrete	Berry Engineering		
4" Minimum Base course compacted & ready for rubber surfacing	3,575	3,575	3,575	3,575	3,575	6/7/2017
New handball walls & footings complete adjacent new playground area, not shown	Excluded	Excluded	Excluded	Excluded	Excluded	7/27/2017
Site Concrete Work at New Building:	Included	Included	Included	126,878	Included	
6" thk Concrete Pavement ove 4" crushed aggregate base (CAB), listed on legend C-002 & per 5/C-702(concrete pavement section detail)	Included	Included	Included	Included	Included	
Rebar #4 @ 18" ocev	w/ Rebar Included	w/ Rebar Included	w/ Rebar Included	w/ Rebar Included	w/ Rebar Included	
Site Control Plan C-201	Included	Included	Included	Included	Included	
Note 1 - 6" thk conc pavement over 4" CAB per 5/C-702	Included	Included	Included	Included	Included	
Note 2 - PCC Pavers & Sand Base per 1/C-703	Included	24,700 Included	24,700 Included	Included	Included	
Pavers MFR-None listed	Included	2,130	2,130	Angelus Included	Included	
24" wide concrete curb at perimeter of PCC Pavers	Included	4,940	4,940	Included	Included	
6" concrete Sub-Slab w/ #4@18"ocew under pavers	Included	4,940	4,940	Included	Included	
Includes removal, excavation and recompaction of top 24" to 95%	w/Demo,Grading	w/Demo,Grading	w/Demo,Grading	w/Demo,Grading	w/Demo,Grading	
Fine Grading prior to your work	Included	Included	Excluded	Excluded	Excluded	
Note 3 - Planter area per Landscape drawings	w/ Landscape w/ Grading	w/ Landscape w/ Grading	w/ Landscape w/ Grading	w/ Landscape w/ Grading	w/ Landscape w/ Grading	
Note 4 - Regrade & resurface the turf area	Included	Included	Included	Included	Included	
Note 5 - 60" Mow Strip at Perimeter of New Building - 2/C-703	Included	Included	Included	Included	Included	
New mowstrip is 12" thk Including over 4" CAB compacted to 95%	Included	Included	Included	Included	Included	
Note 6 - Seat Wall/CIP Benches per Architectural drawings, A-103	Included	Included	Included	28,728	Included	
L-Shaped 20' 4 each: Straight 10', 1 each Detail 10 & 11/A-105 - 1'6"wide x 1'-6" ht CIP Concrete w/ rebar	Included	Included	Included	Included	Included	
Note 7 - Asphalt Pavement per 1/C-702	w/ AC Paving	w/ AC Paving	w/ AC Paving	w/ AC Paving	w/ AC Paving	
Note 8 - Concrete Pavement to Asphalt Pavement Transition 2/C-702	Included	Included	Included	Included	Included	
Note 9 - New Pavement to existing Pavement Joint - 4/C-702	Included	Included	Included	Included	Included	
Note 10 - AC Pavement thickness transition - 7/C-702	w/ AC Paving	w/ AC Paving	w/ AC Paving	w/ AC Paving	w/ AC Paving	
Note 11 - Stairs per Architectural drawings 6/A-105 - Typical CIP stair nosing - extruded aluminum contrasting strip nosing - NO CIP Stairs shown	w/ Steel & CIP	w/ Steel & CIP	w/ Steel & CIP	w/ Steel & CIP	w/ Steel & CIP	
Note 12 - Concrete Curb 3/C-703	Included	Included	Included	Included	Included	

Bid Evaluation Report



Site Concrete

Marshall Classroom Building

Subcontractors

Description	Subcontractors				Engineering
	B&M Contractors	Barcelo Concrete	Santa Clarita Concrete	Toro Ent.	
Note 13 - Rubber Mat Curb - 9/C-702	Included	NEED	Included	Included	Berry Included
Note 14 - Gravity Wall - 7/C-703	Included	Included	Included	Included	Included
Note 15 - Planter Wall per Architectural & Structural drawings - 2 shown on S-211 & 6/S401	w/ CIP Concrete	Yes incl w/ site	w/ CIP Concrete	w/ CIP Concrete	w/ CIP Concrete
Note 15 - Planter Wall per Architectural & Structural drawings - 2 shown near stairs are NOT on S sheets, 36'x8'	w/ CIP Concrete	(30,000)	w/ CIP Concrete	Excluded	Excluded
6/S-401 - 1'-0" thk wall, 1'-6" above grade	w/ CIP Concrete	Yes incl w/ site	w/ CIP Concrete	w/ CIP Concrete	w/ CIP Concrete
Note 16 - Not Used	-----	-----	-----	-----	-----
Note 17 - Rubber Mat per Architectural drawings	w/ Play Equip	w/ Play Equip	w/ Play Equip	w/ Play Equip	w/ Play Equip
Base for all Site Concrete Paving	Included	Included	Included	Included	Included
Reinforcing Steel for All Work	Included	12,025	12,025	12,025	12,025
Control and Expansion Joints / Sealants	Included	Included	Included	Included	Included
Washout Bins	Included	2,500	2,500	Included	2,500
Mock-Ups	Included, if reqd	6,000	6,000	5,575	6,000
SIT.1	(7,000)	(7,000)	(7,000)	(7,000)	(7,000)
SIT.2	(15,000)	(15,000)	(15,000)	(15,000)	(15,000)
SIT.4	(5,000)	(5,000)	(5,000)	(5,000)	(5,000)
SIT.7	(6,000)	(6,000)	(6,000)	(6,000)	(6,000)
TOTALS	147,475	281,534	159,870	191,035	149,460
Recommendation:	Amount				
B&M Contractors	147,475				

Bid Evaluation Report

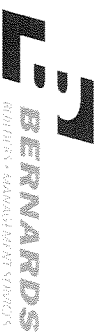

Playfield Equipment

Marshall Classroom Building

Subcontractors

Description	Miracle Playground / Central Coast Playgrounds	Dave Bang Associates / Miracle Playground	SpectraTurf / Miracle Playground	Job Number	1641
				Bid Date	6/7/2017
				Date Printed	7/27/2017
Base Bid	See below	See below	See below		
Spec #: 11 6800 - Playfield Equipment and Structures (Not Provided)	Included	Included	Included		
Spec #: 02 88 00 - Playfield Equipment and Structures (RFI#11 Response)	Included	Included	Included		
Bond Rate (if required)	N/A	Not provided	Bond at 1.5%		
Furnished, Installed, FOB Jobsite, Tax Included	Included	Included	Included		
Plans and Specs Dated: 1/28/2016 & 10/4/2016	Included	Included	Included		
Acknowledgment of RFI's 1-75 dated 6.5.17	Included	Included	Included		
Bid Good for 60 Days	90 Days	30 days	Included		
Prevailing Wage	Included	Included	Included		
Prequalified per Oxnard School District Standards	N/A	N/A	N/A		
Attachment C Acknowledgement	N/A	N/A	N/A		
Playfield Equipment & Structures - Miracle Playgrounds	0	37,210	37,210		
Furnish Modular Units complete FOB Jobsite	Included	Included	Included		
Unloading equipment at jobsite	Included	600	600		
Custom Playground by Miracle Recreation Equipment	Included	Included	Included		
Product spec & cut sheets in RFI#11	Included	Included	Included		
Separate price for Installation:	Included	Included	Included		
Include excavation, layout installation of footings	Included	Included	Included		
Sub provided by Miracle, Central Coast Playgrounds	Included	Included	Included		
Excavate, haul spoils, place embed, install rebar(is this reqd?), place concrete, cleanup	Included	Included	Included		
Footing X: 18" dia x 24" deep	0	8,050	8,050		
Footing Y: 12" dia x 18" deep	0	5,250	5,250		
Footing Z: 20" dia x 42" deep	0	500	500		
Uncrate, separate, install all parts, dispose of empty boxes	0	3,500	3,500		
Playfield Rubber Matting					
Furnish & install complete playground surface as MFR by PlayMax or equal		45,416	42,471		
Demolition Plan C-103, at New Play Area location, remove existing AC Paving		w/ Demo	w/ Demo		
Overexcavate & recompact area after demo		w/ Grading	w/ Grading		

Bid Evaluation Report

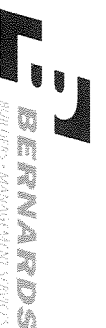

Playfield Equipment

Marshall Classroom Building

Subcontractors

Job Number 1641
 Bid Date 6/7/2017
 Date Printed 7/27/2017

Description	Miracle Playground Equipment / Central Coast Playgrounds	Dave Bang Associates / Miracle Playground	SpectraTurf / Miracle Playground	Amount	
				103,207	100,262
Type 2 sub-base to 95% compaction - thickness to be 4"		w/ Grading	Included		
Geofabric over subbase		2,681	2,681		
Sheet C-203, Note 13 - Rubber Mat Curb - 9/C-702 around perimeter of rubber matting		w/ Site Concrete	w/ Site Concrete		
Rubber Matting subs work:		Included	Included		
MaxPour Cushion Layer - thickness to be xx?		Included	Included		
MaxPour/MaxPour-Supreme Top Layer - thickness to be xx?		Included 4"	Included 4"		
Per cut sheet two products are shown, MaxPour Supreme is not included in price		Tot Turf	SpectraPour		
Max fall height your bid is based upon		Included 9'	Included 10'		
Wear Layer to be 50% black/50% color w/ std aromatic resin		Included	Included		
See detail sheet, possible VE to install over aged asphalt paving		Not recommended	N/A		
Upgrade to Aliphatic (UV-stable, non-yellowing) Resin wear layer		No bid	Add:\$4,934		
Drywell at Rubber Mat Curb at new Play Area Rubber Surfacing 9/C-702, drain shown on C-402		w/ Site Utilities	w/ Site Utilities		
TOTALS		0	103,207	100,262	0
Recommendation:		Amount			
SpectraTurf / Miracle Playground		100,262			

Bid Evaluation Report

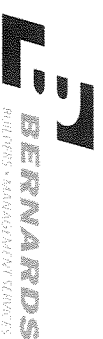

Landscape & Irrigation

Marshall Classroom Building

Subcontractors

Description	Advanced Land. 2000				Job Number Bid Date	1641 6/7/2017
	Cascade Sprinklers	Durau Landscape	Hardy	Plowboy		
Base Bid	29,418	30,500	24,320	46,800	39,600	36,068
Spec #: 323000, 328400, 329000, 329010	Included	Included	Included	Included	Included	Included
Drawings: Planting & Irrigation Specs are also Listed on Sheet L-4	Included	Included	Included	Included	Included	Included
Bond Rate (if required)						
Furnished, Installed, FOB Jobsite, Tax Included	Included	Included	Included	Included	Included	Included
Plans and Specs Dated: 1/28/2016 & 10/4/2016	Included	Included	Included	Included	Included	Included
Acknowledgment of RFIs 1-75 dated 6.5.17	Included	Included	Included	Included	Included	Included
Bid Good for 60 Days	30 Days	30 Days	30 Days	90 days	Included	Included
Prevailing Wage	Included	Included	Included	Included	Included	Included
Prequalified per Oxnard School District Standards	N/A	N/A	N/A	N/A	N/A	N/A
Attachment C Acknowledgement	N/A	N/A	N/A	N/A	N/A	N/A
Landscaping & Irrigation:						
Demolition Plan C-101, at New Building location	Included	Included	Included	Included	Included	Included
Removal Notes:	Included	Included	Included	Included	Included	Included
10 - Contractor to rework existing irrigation as needed to allow for new const. Provide shop drawings for approval of revised/reworked irrigation system prior to re-installation	2,500	2,500	2,500	2,500	2,500	2,500
At New Building per Site Control Plan C-201 & L-1	Included	Included	Included	Included	Included	Included
Note 3 - Planter area per Landscape drawings	Included	Included	Included	Included	Included	Included
Irrigation inside the CIP Planters - L-1	Included	Included	Included	Included	Included	Included
Include tapping into existing mainline for new lines	5,000	5,000	5,000	5,000	5,000	5,000
Sawcut & remove AC paving & put back for access to mainline tap-in	3,000	3,000	3,000	3,000	3,000	3,000
New mainlines & lateral lines for irrigation & rigid pvc for control wire	Included	Included	Included	Included	Included	Included
Include sleeving as required	Included	Included	Included	Included	Included	Included
New Automatic Controller Assembly - Irritrol, 10/L-3	Included	Included	Included	Included	Included	Included
Include Rain Shut-off Sensor	Included	Included	Included	Included	Included	Included
Include remote control valves & gate valves, 1 & 5/L-3	Included	Included	Included	Included	Included	Included
Include quick couplers, 2/L-3	Included	Included	Included	Included	Included	Included
Include pop-up shrub heads, 4/L-3	Included	Included	Included	Included	Included	Included
Electrical to controller	w/ Electrical	w/ Electrical	w/ Electrical	w/ Electrical	w/ Electrical	w/ Electrical
Landscaping inside the CIP Planters - L-2	Included	Included	Included	Included	Included	Included
Trees - 24" box, including Staking per 3/L-3	Included	Included	Included	Included	Included	Included
Shrubs - 1 & 5 gallon	Included	Included	Included	Included	Included	Included
Vines - 15 gallon	Included	Included	Included	Included	Included	Included
Ground Cover	Included	Included	Included	Included	Included	Included
Safety walk and progressive cleanup	4,640	4,640	4,640	4,640	4,640	4,640
90 Day Maintenance	Included	Included	Included	Included	Included	Included

Bid Evaluation Report



Landscape & Irrigation

Marshall Classroom Building

Subcontractors

Description	Subcontractors				Job Number	Bid Date	Date Printed	Venco Western
	Advanced Land. 2000	Cascade Sprinklers	Dufau Landscape	Hardy				
(1) Year Warranty	Included	Included	Included	Included	1641	6/7/2017	7/27/2017	Included
Spills Removal	200	200	200	200				200
Move-Ins (2)	1,500	1,500	1,500	1,500				1,500
Existing Parking Lot Rework, C-202	5,000	5,000	5,000	5,000				5,000
Removal & reinstallation of Irrigation at Demoeed areas	Included	Included	Included	Included				Included
Removal & reinstallation of Planting at Demoeed areas	Included	Included	Included	Included				Included
Existing Grass Field	35,185	35,185	35,185	35,185				35,185
Modify existing Irrigation at grass playground for trailer/laydown area	Included	Included	Included	Included				Included
Geofabric over the grass, rock surface as base during operations	Included	Included	Included	Included				Included
Removal of rock & geofabric at project completion	Included	Included	Included	Included				Included
Regrade, fine grade ready for new grass at laydown area	Included	Included	Included	Included				Included
Rework & start-up existing Irrigation heads	Included	Included	Included	Included				Included
Reinstallation of Grass Planting, hydroseed, at laydown area	Included	Included	Included	Included				Included
TOTALS	86,443	87,525	81,345	103,825				96,625
Recommendation:	Amount							
Dufau Landscape	81,345							

Bid Evaluation Report



Site Utilities

Marshall Classroom Building

Description	Subcontractors				Suttles Plumbing	Toro Ent.
	BSN Construction	J. Vega Engineering	HPS Mechanical	Sam Hill & Sons		
Base Bid	217,229	See below	200,390	See below	245,000	
Spec #: 31 2319 - Excavation & Fill Structures	Included	Included	Included	Included	Included	
Spec #: 31 2323 - Excavation & Fill Utilities	Included	Included	Included	Included	Included	
Spec #: 31 2326 - Base Course	Included	Included	Included	Included	Included	
Spec #: 33 1100 - Site Water Distribution Utilities	Included	Included	Included	Included	Included	
Spec #: 33 3000 - Site Sanitary Sewer Utilities	Included	Included	Included	Included	Included	
Spec #: 33 4000 - Storm Drainage Utilities	Included	Included	Included	Included	Included	
Bond Rate (if required)	Not listed	Not listed	Not listed	Not listed	Bond @1.44%	
Furnished, Installed, FOB Jobsite, Tax Included	Included	Included	Included	Included	Included	
Plans and Specs Dated: 1/28/2016 & 10/4/2016	Included	Included	Included	Included	Included	
Acknowledgment of RFIs 1-75 dated 6.5.17	Included	Included	Included	Included	Included	
Bid Good for 60 Days	30 days	30 days	30 days	30 days	30 days	
Prequalified per Oxnard School District Standards	Included	Included	Included	Included	Included	
Attachment C Acknowledgement	N/A	N/A	N/A	N/A	N/A	
Site Utilities						
Utility Location (C Below)	Included	Included	Included	Included	Included	
Cutting and Capping of Existing Utilities	2,500	2,500	2,500	2,500	2,500	
Layout and Trenching	Included	Included	Included	Included	Included	
Sawcutting & removal of surface for New Utilities	Included	3,584	3,584	3,584	3,584	
Traffic Control	Included	Included	Included	Included	Included	
Temp Asphalt Trench Plates	Included	2,048	2,048	2,048	2,048	
Excavation Spoils Stockpile	Included	Included	Included	Included	Included	
Pressure Test and Flush System	Included	Included	Included	Included	Included	
Sewer						
Site Utility Plan C-401,402,403,404	Included	Included	Included	Included	Included	
Note 20 - Install SDR-353 Sanitary Sewer line per 4/C-701	Included	Included	Included	Included	Included	
Note 21 - Connect to bldg sanitary sewer	Included	Included	Included	Included	Included	
Note 22 - Connect to existing onsite main line	Included	Included	Included	Included	Included	
Note 23 - Install Clean-out per 7/C-701	Included	Included	Included	Included	Included	
Note 24 - Connect to onsite main line per 2/C-701	Included	Included	Included	Included	Included	
Note 25 - House connection per APWA Std Plan 222-2	Included	Included	Included	Included	Included	
Storm Drain						
Site Utility Plan C-401,402,403,404	Included	173,320	Included	143,618	Included	
Note 1 - Install SDR-35 storm drain line per 4/C-701	Included	Included	Included	Included	Included	
Note 2 - Construct 12"x12" catch basin per 6/C-701	Included	Included	Included	Included	Included	
Note 3 - Connect to existing onsite main line per 2/C-701	Included	Included	Included	Included	Included	

Bid Evaluation Report

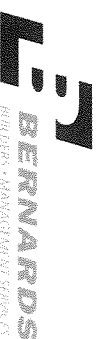

Site Utilities

Marshall Classroom Building

Subcontractors

Description	Subcontractors					Job Number	1641
	BSN Construction	J. Vega Engineering	HPS Mechanical	Sam Hill & Sons	Suttles Plumbing	Bid Date	6/7/2017
						Date Printed	7/27/2017
						Toro Ent.	
Note 4 - Install Clean-out per 7/C-701	Included	Included	Included	Included	Included		
Note 5 - Install Arturn grate NDS 1280 & catch basin 1200 or equal	Included	Included	Included	Included	Included		
Note 6 - Connect to on-site main line per 2/C-702	Included	Included	Included	Included	Included		
Note 7 - Connect to bldg storm drain line	Included	Included	Included	Included	Included		
Note 8 - Install SDR-21 storm drain line per 4/C-701	Included	Included	Included	Included	Included		
Note 9 - Install French Drain per 2/C-704	Included	Included	Included	Included	Included		
Other: Trench Drain concrete basin per 4/S-400A	Included	Included	Included	Included	Included		
Drywell at Rubber Mat Curb at new Play Area Rubber Surfacing 9/C-702, drain shown on C-402	Included	Included	Included	Included	Included		
Water							
Site Utility Plan C-401,402,403,404	Included	64,295	Included	Included	33,353	Included	
Note 30 - Connect to existing onsite main line	Included	Included	Included	Included	Included	Included	
Note 31 - Install 4" Double Check Detector Backflow Preventer Assembly with Fire Department Connection per 3/C-701, Ames 3000 SS OS&Y w/ Tamper Switches connected to Fire Alarm	Included	Included	Included	Included	Included	Included	
Note 32 - Install AWWA C900 PVC pressure Class 200 Water line per 4/C-701	Included	Included	Included	Included	Included	Included	
Note 33 - Install concrete thrust block per 4/C-703	Included	Included	Included	Included	Included	Included	
Note 34 - Connect to bldg Fire Water connection	Included	Included	Included	Included	Included	Included	
Note 35 - Connect to building Domestic Water connection	Included	Included	Included	Included	Included	Included	
Note 36 - Connect to existing onsite main line	Included	Included	Included	Included	Included	Included	
Note 37 - Install Gate valve per 5/C-701	Included	Included	Included	Included	Included	Included	
Note 38 - Fire Department Connection per 1/C-704	Included	Included	Included	Included	Included	Included	
Note 39 - Connect to onsite main water line	Included	Included	Included	Included	Included	Included	
Includes:	Included	Included	Included	Included	Included	Included	
Sawcutting for New Utilities	Included	Included	Included	Included	Included	Included	
Excavation, compact bottom, sand shading, install pipe, backfill, compaction of trench	Included	Included	Included	Included	Included	Included	
Base Pave Trenches	Included	Included	Included	Included	Included	Included	
Overlay trench with new AC Paving section	Included	Included	Included	Included	Included	Included	
Lane Closure/Traffic Control	Included	Included	Included	Included	Included	Included	
Water Line for Irrigation inside the CIP Planters - L-1 (not clearly indicated on C sheets)	2,500	2,500	2,500	2,500	2,500	2,500	
Include tapping into existing mainline for new lines	Included	Included	Included	Included	Included	Included	
Sawcut & remove AC paving & put back for access to mainline tap-in	Included	Included	Included	Included	Included	Included	

Bid Evaluation Report



Site Utilities

Marshall Classroom Building

Subcontractors

Description	Subcontractors				Suttles Plumbing	Toro Ent.
	BSN Construction	J. Vega Engineering	HPS Mechanical	Sam Hill & Sons		
New mainlines & lateral lines for irrigation & rigid pvc for control wire	Included	Included	Included	Included	Included	
Other:						
FDC Bollards & Footings (include if not shown)	1,000	1,000	1,000	1,000	1,000	
POC Flanged into FS min 24" aff room by this sub - 1/FP-02	Included	Included	Included	Included	Included	
Gas						
NOT SHOWN on Site Utility Plan C-401,402,403,404	Included	Included	Included	Included	Included	
Gas Lines per Plumbing Sheets	Included	Included	Included	Included	Included	
Connect to existing Gas Line onsite - Not Shown	See Allowance	See Allowance	See Allowance	See Allowance	See Allowance	
TOTALS	228,861	325,112	212,022	210,055	256,632	0
Recommendation:	Amount					
Sam Hill & Sons	210,055					

BOARD AGENDA ITEM

Name of Contributor: Janet Penanhoat

Date of Meeting: 4/3/19

STUDY SESSION _____

CLOSED SESSION _____

SECTION A-1: PRELIMINARY _____

SECTION A-II: REPORTS _____

SECTION B: HEARINGS _____

SECTION C: CONSENT AGENDA _____

Agreement Category:

____ Academic

____ Enrichment

____ Special Education

____ Support Services

____ Personnel

____ Legal

X Facilities

SECTION D: ACTION _____

SECTION F: BOARD POLICIES 1st Reading _____ 2nd Reading _____

Approval of Contractor Contingency Allocation No. 008 to Construction Services Agreement #17-117 with Bernards Bros. Inc. for the Marshall New Classroom Building Project (Penanhoat/Fateh/CFW)

The Oxnard School District (“District”) Board of Trustees (“Board”) Facilities Implementation Plan first adopted in January 2013, calls for the construction of the new classroom building at Marshall School (“Project”). The Project includes the construction of a new school building at the existing Marshall School site.

During the Regular Meeting of August 23, 2017, the Board of Trustees Approved Item C-12, the Construction Services Agreement between the Oxnard School District and Bernards for the Project. During that Meeting, the inclusion of a Three Hundred Forty-Five Thousand Nine Hundred Thirty-Two Dollars and No Cents (\$345,932.00) Contractor Contingency was explained. The Contractor Contingency is for payment of very specific items of Work: (1) additional costs resulting from discrepancies in the bid buy-out process; (2) conflicts, discrepancies or errors in the Construction Documents; (3) work required by the Inspector of Record or any governmental agency involved with the permitting or approval/certification process that is not otherwise shown in the Construction Documents; and (4) any other items of cost agreed to in writing by the Contractor and District to be included in the Contractor Contingency.

Contractor Contingency Allocation No. 008 provides for the Board’s approval of four (4) items of cost agreed to in writing by the Contractor and District to be drawn from the Contractor Contingency. Contractor Contingency Allocation No. 008 will not increase Contract Time.

FISCAL IMPACT

Contractor Contingency Allocation No. 008 will be a **COST** to the Contractor Contingency line item of the GMP Construction Services Agreement in the amount of **Thirty-Five Thousand Seven Hundred Ninety Dollars and Zero Cents (\$35,790.00)** to be paid out of the Master Construct and Implementation Funds.

The Contractor Contingency is included within the approved total of the Construction Services Agreement for the Marshall New Classroom Building Project. The remaining Contractor Contingency balance after Allocation No. 008 will be Seventy-One Thousand Eight Hundred Ninety-Nine Dollars and Zero Cents (\$71,899.00).

RECOMMENDATION

It is the recommendation of the Assistant Superintendent, Business & Fiscal Services, and the Director of Facilities, in conjunction with Caldwell Flores Winters, Inc., that the Board of Trustees approve Contractor Contingency Allocation No. 008 to Construction Services Agreement #17-117 with Bernards, for additional items of Work related to the Marshall New Classroom Building Project.

ADDITIONAL MATERIAL

Attached:

- *Contractor Contingency Allocation No. 008, Bernards Bros. Inc. (2 Pages)*
- *CAR No. 27RO Revised Holdown Columns (28 Pages)*
- *CAR No. 41R1 Additional Student Lockers (10 Pages)*
- *CAR No. 63 New 6x6 Posts with ECCO66 (6 Pages)*
- *CAR No. 69 Additional Strap Connection (12 Pages)*
- *Construction Services Agreement # 17-117, Bernards Bros. Inc. (115 Pages)*



CONTRACTOR CONTINGENCY ALLOCATION APPROVAL

Date: April 3, 2019

CONTRACTOR CONTINGENCY ALLOCATION NO. 008

PROJECT: MARSHALL NEW CLASSROOM BUILDING
O.S.D. BID No. N/A
O.S.D. Agreement No. 17-117

OWNER: Oxnard School District
 1051 South A Street
 Oxnard, CA. 93030

ARCHITECT CSDA Design Group
 4061 Glencoe Ave., Suite B
 Marina Del Rey, CA 90292

CONTRACTOR:

Bernards Bros. Inc.
 555 First Street
 San Fernando, CA 91340
 Attn: Carl Magness

Architects Proj. No.: 1534.01
D.S.A. File No.: 56-22
D.S.A. App. No.: 03-116806

CONFORMANCE WITH CONTRACT DOCUMENTS, PROJECT MANUAL, DRAWINGS AND SPECIFICATION. All Contractor Contingency Allocation work shall be in strict conformance with the Contract Documents, Project Manual, Drawings, and Specifications as they pertain to work of a similar nature.

ORIGINAL CONTRACTOR CONTINGENCY SUM	\$	345,932.00
NET CHANGE – ALL PREVIOUS CONTRACTOR CONTINGENCY ALLOCATION	\$	238,243.00
ADJUSTED CONTINGENCY SUM	\$	107,689.00
NET CHANGE	\$	35,790.00
<hr/>		
Total Contingency Allocations to Date:	\$	274,033.00
ADJUSTED CONTRACTOR CONTINGENCY SUM THROUGH NO.: 008.....	\$	71,899.00

Item	Description	Additional Cost related to Bid/Buy-out	Conflicts, Discrepancies or Errors in the Construction Documents	Additional Work required by IOR, or another Jurisdictional Agency, not in plans	Other Item of Cost agreed to by District and Contractor
1.	CAR 27R0- Revised Holdown Columns		\$15,431.00		
2.	CAR 41R1- Additional Student lockers				\$18,388.00
3.	CAR No. 63- New Post 6x6 Post with ECCO66		\$712.00		
4.	CAR No. 69- Additional Strap Connection		\$1259.00		
	Totals		\$17,402.00		\$18,388.00

Total Contractor Contingency Allocation Approval No. 008 \$ 35,790.00

****NOT VALID UNTIL SIGNED BY THE ARCHITECT, CONTRACTOR AND ASST. SUPERINTENDENT OR PURCHASING DIRECTOR***

APPROVAL (REQUIRED):

ARCHITECT: _____

DATE: _____

CONTRACTOR: _____

DATE: _____

RECOMMENDED FOR APPROVAL:

ASST. SUPERINTENDENT, BUSINESS & FISCAL SERVICES

DATE: _____

APPROVAL (REQUIRED):

PURCHASING DIRECTOR: _____

DATE: _____



CONTINGENCY ALLOCATION REQUEST

Project: Marshall Elementary - New 6-8 Classroom Bldg.

CAR No. 27 R0

Date: 4/30/2018

DESCRIPTION OF WORK

CCD 20 Revise holddown columns

SUMMARY OF ALLOCATIONS

Item Description	Company	Amount Requested
Contractual Costs		
Contingency Allocation		-15,431
	Subtotal:	-15,431

SUMMARY OF ALLOCATIONS

Item Description	Company	Amount Requested
Subcontract Costs		
CCD 20 Revise holddown columns	C. A. Buchen Corp	15,431
	Subtotal:	15,431

Total Change Order Request Amount 0

ACKNOWLEDGEMENT

Oxnard School District

Bernards Bros. Inc.



 Signature

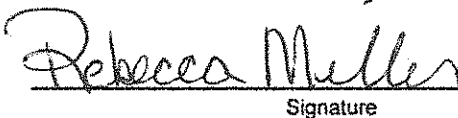

 Signature

Jose Arche CSDA

Rebecca Miller Project Manager

Printed Name & Title

Printed Name & Title

08/29/18

8/8/19

Date

Date



c.a. buchen corp.

9231 Glenoaks Blvd., Sun Valley, CA 91352***Tel. (818) 767-5408***Fax (818) 767-8654

STANDARD PROPOSAL/CONTRACT FORM
CONTRACTORS LIC #209850
DIR #1000004833

Date: April 25, 2018

TO: Bernards Builders Management Services

ADDRESS: 555 First Street
San Fernando, CA. 91340

ATTENTION: Rebecca Miller (805) 394-9471

C.A. BUCHEN CORP hereinafter called the Seller, proposes to furnish the materials and work as listed below, according to the plans and specifications exhibited to us, subject to the latest Code of Standard Practice of the American Institute of Steel Construction; and to all terms and conditions herein, for the sum of:

*****FIFTEEN THOUSAND FOUR HUNDRED THIRTY ONE & 00/100 DOLLARS***** (\$15,431.00)
Including all taxes now in effect

SPECIFICATIONS:

Name of Job: Marshall Elementary School Specification Section:
Location: 2900 Thurgood Marshal Dr. Oxnard, CA Addendum Noted: C.O.R #09 Job #A190
Architect: Sheet Numbers:

SCOPE OF WORK:

Re: Revising holddown columns RFI 128, 128R and CCD 020 (Per incorrect detail used by SEOR in RFI#128 response)
Per submittal 049-051200-0 approvers holddown column comments referred to detail 19/AS-600F. This detail shows a (beam per plan). As a result we submitted new drawings for review 2/12/18 with saddles. RFI 128 clarified no saddles, RFI 128R referred to detail 15/S-600 bolted holddown detail at 2nd floor which indicates top of column to bottom of wood plates. Per CCD 020 elevation of 10 columns required to be cut down 14" to bottom of floor joist. Add 10 piece 1/4 X 4 X 3 angle bracket and 10 piece 1/4 X 4 X 4 angle brackets. Mag drill new holes in columns for HD 19. Scope also includes job site meeting and review 4/2/18 and to revise detailing of columns for 3rd time for as builds due to lack of specific details on plans and misrepresentation of corrections on approval drawings & RFI's

*The Subcontract Price is based on the current prices and surcharges for the steel types and shapes necessary for the Project as posted and made publicly available. Notwithstanding anything herein to the contrary, any increases or decreases in the price of the steel ordered by the Subcontractor for the Project, or any additional surcharges imposed on the steel ordered by the Subcontractor of the Project shall result in a corresponding dollar-for-dollar increase (or decrease) in the Subcontract Price.

Field Conditions:

- 1. Contractor to provide free and clear access (graded if necessary) to interior and exterior of building for trucks and erection equipment.
2. All anchor bolts to be chased and cleaned by others and left with leveling nuts set to correct elevations after having been properly set and straightened.
3. Two-line safety cable at building perimeter (if included above in scope of work) to be maintained and removed by others.
All safety cable materials to be coiled and stored on ground by others for CABCO pick up.
4. Any protection required at floor or roof penetrations shall be provided by others so as not to delay the continuous erection of structural steel.

EXCLUSION: This proposal does not include the following items, unless specifically noted above:

Table with 3 columns listing excluded items: Bolts entering wood, Building permits, Carpentry and Gou-Lam hardware, Concrete reinforcing steel, Costs of bond and special insurance, Costs of inspection, testing and preparation, Cutting or drilling of our work to accommodate other trades, Demolition, cutting or drilling concrete, Field painting and field measuring, Removal & replacement of fire proofing, Field welding of concrete steel reinforcing steel to structural, Final and fine plumbing of columns supporting wood, Furring channels or angle, Glass stops, Gratings, covers and frames, Grouting or dry-packing, Jowl hangers not welded to steel, Manlift and costs for use thereof, Metal 10 gauge and lighter, Metal studs and metal sash, Non-ferrous metals and stainless steel, Participating in penalties or liquidated damages applied to Buyer, Pipe sleeves and back-up plates for other trades, Removal of bracing rods and cables, Roof hatches or access doors, Sandblasting or flame-cleaning of steel before painting, Temporary safety railings and cables, Wire mesh or chainlink work, Wood nailers, Work that is not specifically detailed on Architectural or Structural drawing.

THIS PROPOSAL INCLUDES THE TERMS AND CONDITIONS ON THE REVERSE SIDE HEREOF, AND IS SUBJECT TO YOUR WRITTEN ACCEPTANCE WITHIN THIRTY (30) DAYS FROM DATE. WHEN ACCEPTED BY YOU WITHIN SUCH TIME, THIS PROPOSAL WILL CONSTITUTE A CONTRACT OF SALE BETWEEN YOU AND OURSELVES AS PURCHASER.

Accepted:

Buyer: _____
By: _____
Printed Name & Title

Seller: C.A. Buchen Corp.
By: John A. Oster - President

Date: _____

Date: _____

SALES CONDITIONS

Article 1: STEEL PRICES The quoted price on the attached proposal is based on current steel warehouse prices in effect at the date of our proposal. Those published warehouse prices are subject to change without notice, and are subject to surcharges of various types.

Article 2: DRAWING & SPECIFICATIONS The material shall be fabricated and, if called for in the scope of work in this contract, erected in accordance with (a) the steel design drawings and specifications listed in this contract (see Specifications) and (b) shop detail drawings prepared by Seller. If such design drawings and specifications are preliminary or incomplete, Buyer shall promptly furnish design drawings and specifications which are complete, final and fully approved by the state, county or city building department having jurisdiction thereof. Any difference between the complete, final and approved drawings and specifications and those listed on the specifications in this contract shall be deemed a change in the work ordered under Article 4 hereof. Details and workmanship of fabrication and erection shall conform to the Specification published in the Manual of the American Institute of Steel Construction, and to its latest code of Standard Practice of the American Institute of Steel Construction. Buyer shall cause shop drawings to be returned to Seller within fourteen (14) calendar days after submittal marked "approved" or "approved as corrected".

Article 3: INSPECTION OR TESTS Upon Buyer's written request, Seller shall furnish copies of the steel mill test reports, provided Buyer's written request therefore is received prior to the date on which Seller has placed its mill order for the required steel or withdrawn steel from its stock. Seller will also arrange for further tests and inspection, in the shop or field or in a laboratory, of any of the material called for hereunder. Unless the furnishing of such tests and inspections are specifically called for in the scope of work in this contract, they shall be furnished at Buyer's expense and only after receipt of Buyer's written order therefore. Buyer may inspect fabricated materials before shipment from Seller's plant, provided that Buyer give Seller adequate notice of intention so to do and also furnish the name of inspector. Inspection of materials and workmanship at the erection site shall be performed in such manner as will not interfere with Seller's performance. Seller shall correct or replace any materials or workmanship condemned by Buyer's inspectors during the progress of the work which do not meet the contract requirements. Defective materials which are replaced shall be removed from the erection site.

Article 4: GUARANTEE At Buyer's written request and at any time within one year from the date of completion of the work covered by this contract, Seller shall replace or correct any fabricated material which contains defects not discoverable by visual inspection during fabrication or erection and any workmanship which is defective or not in conformance with the contract requirements. Seller's liability for any losses and damages sustained by Buyer or by others as a result of any defective materials or workmanship furnished by Seller under this contract shall be limited to the replacement or correction of such defective material and workmanship within the time above stated and Seller shall not be liable for any other direct or consequential loss, damage or liability resulting from defective material and workmanship.

Article 5: CHANGES IN THE WORK Seller shall make changes in the work which Buyer may order in writing provided that such changes do not constitute material alterations. If the parties are unable to agree upon the amount of the increase in price to be charged for additional work or the credit to be allowed for reductions in the work, Seller shall, nevertheless, proceed to make such changes in accordance with Buyer's order, provided that Buyer furnish all necessary information and all work to be done by others has been properly performed; and upon completion of execution of such change order Buyer shall pay to Seller its costs of performing the additional work, computed according to Seller's established accounting practices, as certified by its accountant plus ten per cent thereof for profit, or Buyer shall be credited with the amount of any savings, similarly computed and certified, resulting from any reduction in the work.

Article 6: LIABILITY The Seller will indemnify the Buyer against loss or expense by reason of liability imposed upon the Buyer by law for damages resulting from death of or injury to persons or destruction of property occurring during the performance of Seller's work to the extent that such death, injury or damage shall have been solely due to the negligent act or omission of the Seller, its agents or employees. However this indemnity will not extend to Seller, its agents or employees. However, this indemnity will not extend to any claims, loss, damage, or expense arising out of the negligent or willful misconduct of the owner, owner-builder or contractor or any of their agents, employees, servants, consultants, professional experts or independent contractors.

Article 7: WORKMEN'S COMPENSATION INSURANCE The Seller shall carry Workmen's Compensation insurance for the protection of all labor used in the construction of the said structure, employed by the Seller. The Buyer agrees to provide adequate and safe working conditions for the employees of the Seller in and about the work herein specified.

Article 8: PATENTS Seller shall indemnify and save Buyer harmless from and against liability for patent infringement due to any inventions incorporated in the products fabricated and/or erected hereunder in compliance with designs or specifications furnished by Seller. Buyer shall indemnify Seller and save him harmless from and against liability for patent infringement resulting from Seller's compliance with designs and specifications furnished by Buyer.

Article 9: BUILDER'S RISK Buyer shall assume all risk of loss or damage to all work incorporated in the structure and all material located in and about the erection site due to the occurrence of any insurable builder's risk (including, but not limited to, fire, flood, wind, hurricane, earthquake, defective soil or any cause which Seller could not have reasonably foreseen and guarded against). To the extent of Seller's insurable interest, Buyer shall name Seller as co-insured in any policy or policies of builder's risk insurance which Buyer may carry covering such work and material during the period of construction. To the extent any such loss or damage is not compensated by insurance, Buyer shall reimburse Seller for all added costs incurred by him in repairing or replacing material or work which is damaged or destroyed.

Article 10: DELIVERIES, DELAYS AND CANCELLATIONS

(a) If all required information, (including complete, final approved, design drawings and specifications) shall be furnished to Seller, and all work to be done by others shall be performed and completed in such time and manner as will not delay or interfere with Seller's work, all work called for hereunder shall be promptly delivered or completed. If Seller is delayed due to causes for which Buyer or those acting for Buyer (such as Buyer's other contractors or their subcontractors) are responsible, the time for delivery or completion of the work called for hereunder shall be extended for such period as may reasonably be necessary to enable Seller to perform a complete its work and Buyer shall reimburse Seller for any and all costs and expenses which he may incur as a direct result of any such delay.

(b) Any specified delivery or completion dates shall be correspondingly extended if and to the extent Seller is delayed in the performance of the work by floods, fires, earthquakes, epidemics, acts of God, labor disputes or slow-downs, riots, insurrections of war, governmental regulations, delays in receipt, or shortages of material, or by any cause beyond Seller's reasonable control.

(c) If for any reason Buyer is unable to accept scheduled delivery of fabricated materials or to permit delivery of materials at the erection site designated herein, then Buyer shall pay Seller, upon demand, the contract price for such material, less the value (computed according to Seller's established accounting practices) of any work hereunder remaining to be performed, and also reimburse Seller for all costs and expenses incurred in storing, caring for, handling and disposing of such material.

(d) Unless otherwise expressly provided herein, all work shall be performed during regular working hours of regular working days. If Buyer should require overtime, the added cost thereof shall be reimbursed to Seller, in addition to the contract price.

(e) Unless specifically expressed herein, steel is to be shop-painted with the Seller's standard primer, and the Seller will not be responsible for the condition of the paint after this work has been delivered to the custody of others.

Article 11: ERECTION CONDITIONS If erection is called for in the specifications listed in this contract, Buyer shall without cost to Seller:

(a) Provide adequate foundations of proper height, any required wood blocking and/or wood backing for horizontals, place wood-posts, shores and wall-plates to correct elevations and dimensions, set all anchor bolts, leveling plates and loose column base plates, and establish all levels and datum lines. Buyer to promptly report in writing to the Seller any deviations in the work of others which could cause a misfit in the Seller's work.

(b) Schedule operations so that erection work of Seller may be carried out in proper sequence and with a single erection trip and in one continuous operation, unless more than one trip would necessarily be required.

(c) Provide and maintain necessary ingress and egress, and a firm and properly graded site that is free of all obstructions over the entire building area, safe for Seller's employees, and suitable for the safe operation of loaded trucks and crawler and truck cranes without use of planks or supporting pads, excepting only in those cases where normal erection practice necessitates truck and crane operation over existing concrete, paving or flooring.

(d) Remove any overhead obstructions to erection, including wires, before arrival of Seller's equipment at the site;

(e) Furnish, place and maintain necessary lights, barricades, flagmen, safety railings, planking, overhead protection, and do and perform all things so required by the ordinances of the state, city or county in which the structure is located, or the rules and regulations of any of the departments of said state, city or county.

Article 12: TERMS OF PAYMENT The terms of payment shall be:

(a) Material only: Net 10th for material delivered the previous month.

(b) Material not in place: Payments to be made on or before the 10th of each month covering 95% of the contract value of all materials stored during the preceding month.

(c) Material installed in place: Payments to be made on or before the 10th of each month, covering 95% of the contract value of all materials installed in place during the preceding month. Balance of 5% to be paid within 30 days after completion of work covered by the terms of this Agreement. The entitlement of the Seller to payment shall be absolute and not contingent upon the Buyer receiving payment for such work.

(d) If payment is to be made on the basis of the weight of materials and the method of calculating weights is not specified, materials shall be invoiced on the basis of weights calculated from detail drawings and shop bills in accordance with the method of calculating weights prescribed in the latest Code of Standard Practice of the American Institute of Steel Construction.

(e) Unit paid for, the title to and ownership and right of reposition of the material covered by this contract shall be and remain in the Seller, should the Buyer become insolvent or refuse or neglect to pay for said material.

(f) No charges for labor or material furnished by the Buyer shall be allowed as a credit on this agreement, unless authorized in writing by the Seller.

All payments shall be made as stipulated at the address of the Seller. When not so paid, then the entire contract price shall become immediately due and payable. The Buyer agrees to pay the Seller interest on all past due balances at the rate of the higher of (a) ten percent (10%) per annum (0.833% per month), or (b) five percent (5%) per annum, plus the rate prevailing on the 25th of the month preceding the acceptance of this Proposal-Contract, established by the Federal Reserve Bank of San Francisco or advances to member banks under Sections 13 and 13 (a) of the Federal Reserve Act as in effect on said date of acceptance or as may be thereafter from time-to-time amended (or, if there is no such single determinable rate of advances, the closest counterpart of such rate as shall be designated by the Superintendent of Banks of the State of California unless some other person or agency is delegated such authority by the Legislature.

Article 13: ATTORNEYS FEES If any Party brings an action or proceeding to enforce the terms hereof or declare rights hereunder, the Prevailing Party in any such proceeding, action or appeal thereon, shall be entitled to reasonable attorney's fees. Such fees may be awarded in the same suit or recovered in a separate suit, whether or not such action or proceeding is pursued to decision or judgment. The term, "Prevailing Party" shall include without limitation, a Party who substantially obtains or defeats the relief sought, as the case may be, whether by compromise, settlement, judgment, or the abandonment by the other Party of its claim or defense. The attorney's fees award shall not be computed in accordance with any court fee schedule, but shall be such as to fully reimburse all attorney's fees reasonably incurred. Seller shall be entitled to attorney's fees, costs and expenses incurred in the preparation and service of notices of Default and consultations in connection therewith, whether or not a legal action is subsequently commenced in connection with such Default or resulting Breach.

Article 14: ARBITRATION Any claim arising out of or related to this Subcontract, except those waived in this Subcontract, shall be subject to arbitration. Claims shall be decided by arbitration which, unless the parties mutually agree otherwise, shall be in accordance with the Construction Industry Arbitration Rules of the American Arbitration Association currently in effect. Demand for arbitration shall be filed in writing with the other party to this Subcontract and with the American Arbitration Association, and a copy shall be filed with the Architect.

Limitations on Consolidation of Joinder. Except by written consent of the person or entity sought to be joined, no arbitration arising out of or relating to the Subcontract shall include, by consolidation or joinder in any other manner, any person or entity not a party to the Subcontract under which such arbitration arises, unless it is shown at the time the demand for arbitration is filed that (1) such person or entity is substantially involved in a common question of fact or law, (2) the presence of such person or entity is required if complete relief is to be accorded in the arbitration, (3) the interest or responsibility of such person or entity in the matter is not insubstantial, and (4) such person or entity is not the Architect, the Architect's employee, the Architect's consultant, or an employee or agent of any of them. This agreement to arbitrate and any other written agreement to arbitrate with an additional person or persons referred to herein shall be specifically enforceable under applicable law in any court having jurisdiction thereof.

Claims and Timely Assertion of Claims. The party filing a notice of demand for arbitration must assert in the demand all claims then known to that party on which arbitration is permitted to be demanded.

Judgment on Final Award. The award rendered by the arbitrator or arbitrators shall be final, and judgment may be entered upon it in accordance with applicable law in any court having jurisdiction thereof.

SHOULD YOU DESIRE TO ENTER INTO A CONTRACT ON THE TERMS AND CONDITIONS SET FORTH ABOVE, PLEASE SO INDICATE BY SIGNING ON PAGE 1 AND INITIALING BELOW AND RETURN TO US WITHIN 30 DAYS FROM THE ABOVE DATE HEREOF, ONE COPY OF THIS PROPOSAL WHICH SHALL BECOME A CONTRACT SUBJECT TO THE APPROVAL OF THE BUYER'S CREDIT. SUCH CREDIT SHALL BE DEEMED APPROVED UNLESS BUYER IS GIVEN WRITTEN NOTICE TO THE CONTRARY, WITHIN 10 DAYS AFTER SELLER HAS RECEIVED BUYER'S ACCEPTANCE OF THIS PROPOSAL.

Initials: _____

				Date: 04/24/18
Marshall Elementary School				
SNC COR	1a	SUBJECT: REVISED WOOD TO COLUMN CONNECTION PER REPLY TO SNC RFI#009 (RFI128R) & CCD018		
		FROM: REV 0 ISSUE	DATE:	04/24/18
DESCRIPTION		HOURS	REMARKS	
a.	E101 & E102	REMOVED CLOUDS PER REPLY TO SNC RFI# 009 (BERNARDS RFI 128R)	4	
b.	102C2, 103C1, 104C3, 105C1, 106C2, 110C3, 110C4, 125C1, 126C3, 127C1, 127C2, 127C3, 127C4	<p>>PER DESIGN WE USED TYPICAL SECT. PER DET. 13/S-700 (2- L'S CONNECTION @ WOOD JOISTS AS THERE IS NO GLB ON PLAN PER S-212)</p> <p>>APPROVAL COMMENT STATES DET. 19/A-600F SHOULD BE USED, SADDLE PL'S OVER HSS COLUMN FOR GLB CONNECTION</p> <p>>SNC RFI-009 (BERNARDS RFI 128) REPLY SAYS TO REMOVE ANGLES BECAUSE THEY WOULD CONFLICT W/ HD CONNECTION SHOWN ON 19/A-600F</p> <p>>RFI 128R WAS SENT TO CLARIFY THE ENGINEER'S RESPONSE WHICH SHOWS A MODIFIED DETAIL 15/S-600 WHICH WE FOLLOWED.</p>	84	LARCO CO REQ. # 09
c.	E107, E108, 123FR1	NEW HSS8x4x.25 BEAM @ CANOPY PER CCD#018 /SK-01 TO 03	12	
Subtotal Revision:		100.00 hours		
TOTAL REVISION MAN HOURS			100	

C.A. Buchen Corp.

Change Order Backup

To: Bernards Builders

Regarding project:

Attn: Rebecca Miller

Marshal E.S

Job#: SE-A190

Date: 4/25/2018

Request for change order # 09

1	<u>Project coordination</u>	8	hr @	\$ 80.00		\$640
2	<u>Field measure</u>	7	hr @	\$ 80.00		\$560
3	<u>Detailing</u>	84	hr @	\$ 80.00		\$6,720
4	<u>Shop labor</u>	5	hr @	\$ 86.40		\$432
5	<u>Ironworker</u>	44	hr @	\$ 86.40		\$3,802
7	<u>Materials:</u>					
	# W.F			\$ 0.60	/lb	\$0
8	# PL/HSS				/lb	
9	Angle	50		\$ 0.75		\$38
10	M. Channel			\$ 1.00		\$0
11	<u>Galvanizing</u>		Lb	\$ 1.00	/lb	\$0
	<u>Zinc Primer</u>		Lb	\$ 1.00	/lb	\$0
12	<u>Buy outs:</u>					
	Cane Bolts			\$ -		\$0
13	Casters			\$ -		\$0
14	Hinges			\$ -		\$0
15	Deck			\$ -		\$0
16	Mesh Panels			\$ -		\$0
17	<u>Delivery&Pickup</u>	1	round trip	\$ 320.00		\$320
	<u>Semi Delivery</u>		round trip	\$1,100.00		\$0
18	<u>Crane</u>		hr @	\$ -	varies	\$0
19	<u>Crane in/out</u>			\$ -	vary per crane size	\$0
20	<u>Man lift</u>		day @	\$ -	varies	\$0
21	<u>8K - Fork lift</u>		day @	\$ 300.00	plus delivery	\$0
22	<u>Field equip:</u>					
	<u>Stick weld</u>		hr @	\$ 20.00	(250cc)	\$0
23	<u>Innershield</u>	7	hr @	\$ 25.00	(300- 400cc)	\$175
24	<u>F.P. inshield</u>		hr @	\$ 25.00	(650cc)	\$0
25	<u>Grinder</u>	3	hr @	\$ 2.00		\$6
26	<u>Working field truck w/tools</u>	22	hr @	\$ 25.00		\$550
27	<u>Maq Drill</u>	19	hr @	\$ 5.00		\$95
28	<u>Burning outfit</u>	6	hr @	\$ 13.00		\$78
29	<u>Special equipment</u>		hr @	\$ 9.00	Air-arc	\$0
30	<u>Special equipment</u>		day @	\$ 70.00	Fire blanket shield	\$0
					Subtotal	\$13,415
	<u>Tax on materials & galvanizing (9.5%)</u>					\$4
	Profit & Overhead		15%			\$2,013
					Total this change order	\$15,431

(cabco) c.a. buchen corp.

9231 glen Oaks blvd. sun valley, california 91352-2688 (818) 767-5408 • fax (818) 767-8654

Job Name Marshall Elementary Date of Work 4-10-18
 Location Orland Cabco Job No. SE-A190
 Contractor Bernards Contractor Job # _____

EMPLOYEE NAME	FOREMAN	JOURNEY- MAN	APPREN- TICE	HOURS WORKED		
				ST	OT	2T
Don T	✓			6		
Ramon		✓		6		
TOTAL HOURS				12		

DESCRIPTION OF WORK/EQUIPMENT (Repair/CCD 0201)

(1-field truck), Delivered angles for columns HD, used torch setup
cut the top of Column # 102C2, 125C1, 126C3, 103C1, 105C1, 125C3, 125C2
7' tall, drilled 6 new holes with mag drill, shot in etc for col heights
to cut down.

CONTRACTOR'S SUPERVISOR:

Will Van Bee
 PRINTED NAME

Will Van Bee
 SIGNATURE





REQUEST FOR INFORMATION

RFI No.: 128 R

To: Jose Arche
Company: CSDA Design Group
Project: Marshall Elementary - New 6-8 Classroom Bldg.
Subject: GLB information clarification

Date: 02-13-18
Discipline: Structural

Response Requested By: 02-20-2018

DRAWINGS & SPECIFICATION REFERENCES

Table with 3 columns: Drawing Sheet / Specification, Detail / Sub Section, Comments

QUESTION

Per RFI128 Response, please confirm / clarify the following:
1) 1/4"x 4"x 4" angle to be removed from these columns and holes added per attached sketch. Please approve sketch
2) See list of columns affected by RFI 128, several of which were not corrected on the shop drawing submittals. Please confirm the list below.
Columns:
102C2 (CONFIRMED)
125C1 (CONFIRMED)
106C2 no connection for HD shown on submittal? (CONFIRMED)
126C3 no connection for HD shown on submittal? (CONFIRMED)
103C1 (CONFIRMED)
105C1 (CONFIRMED)
125C3 (CONFIRMED)
125C2 no correction for HD shown on submittal? (CONFIRMED)
127C3 One column only GL 19 and 3' 10" south of GL "E". (CONFIRMED)
127C3SNC Detailing. One column north of GL "D" & 19 is not an HD column. No shearwall/holddown above. Use angles at this column.
110C3 One column only GL 19 and 9' 8 1/2" south of GL "E". (CONFIRMED)
127C1 Two columns (CONFIRMED)
127C2 (CONFIRMED)

ANSWER

NC Response:
Sketch appears to be in general conformance with contract documents. Please note that some locations require (2)HD's
See above for confirmation on various column locations.

By: DY/NC 02/13/18
Response Provided By: _____
Name Company Date

Question Initiated By: Jack Furdek - C. A. Buchen Corp - Author Number: 18
Submitted By: Jack Furdek - C. A. Buchen Corp

RE: RFI 128 RESPONSE

REF. DETAIL 15/ (ROUTED HLDN DETAIL @ 2ND FLOOR)
S-600

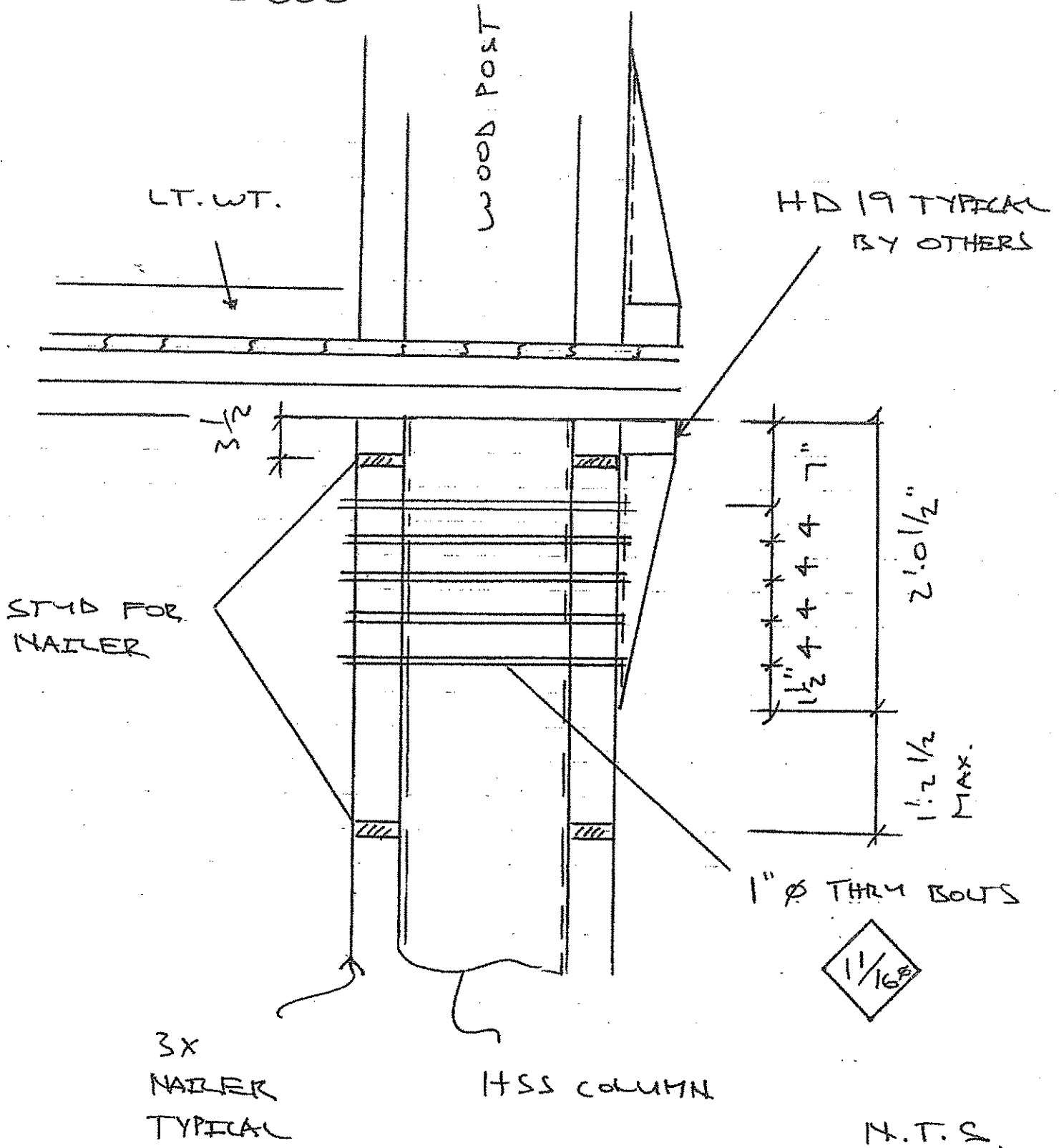

(cabco) c.a. buchen corp.

9231 glenooks blvd. sun valley, california 91352-2688 (818) 767-5408 • fax (818) 767-8654

Job Name Marshall Elementary Date of Work 4-11-18
 Location Oxnard Cabco Job No. SE-A190
 Contractor Bernards Contractor Job # _____

EMPLOYEE NAME	FOREMAN	JOURNEY-MAN	APPREN-TICE	HOURS WORKED		
				ST	OT	2T
Dan	✓			6	CCD 020	
Ramon		✓		6	CCD 020	
TOTAL HOURS				12		

DESCRIPTION OF WORK/EQUIPMENT (Repair - CCD 020)

1-Field Truck. They work on a layout of holes on columns, mag drilling
holes on column #10222, 125C1, 1X6 3, 10301, 10602, 10501, 12503, 10502
ground down top of columns w/ the glider, started weld on 4x4 angles on the
columns - made ready for column erection #55 5x5x4

CONTRACTOR'S SUPERVISOR:
Will [Signature] PRINTED NAME
[Signature] SIGNATURE



cabco c.a. buchen corp.

9231 glen Oaks blvd. sun valley, california 91352-2688 (818) 767-5408 • fax (818) 767-8654

Job Name Marshall Elementary Date of Work 4-12-18
 Location oxnard Cabco Job No. SE-A190
 Contractor Bernard Contractor Job # _____

EMPLOYEE NAME	FOREMAN	JOURNEY-MAN	APPREN-TICE	HOURS WORKED		
				ST	OT	2T
Don T	✓			1	STUBS	
Ramon		✓		1	STUBS	
				"		
Don				5	CCD020	
Ramon				5	CCD020	
TOTAL HOURS				16		

DESCRIPTION OF WORK/EQUIPMENT:

one field truck, hand welded studs on column #125E1, welded 4x4x1/2 angles on HD #102L2, 125C1, 125C3, 103C3, 105E3, 125C2, 103C2, 110C3, 110C4, put on new HSS5X5 column on work 110C3 welded joints, painted, signed a report to the client for the work done.

CONTRACTOR'S SUPERVISOR:

Will
 PRINTED NAME

[Signature]
 SIGNATURE



Job Name Marshall Elementary Date of Work 4-13-18
 Location Oxnard Cabco Job No. SE-A190
 Contractor Bernard Contractor Job # _____

EMPLOYEE NAME	FOREMAN	JOURNEY-MAN	APPREN-TICE	HOURS WORKED		
				ST	OT	2T
Don T	✓			2	STUBS	
Ramon		✓		2	STUBS	
DON				5	CCD 020	
Ramon				5	CCD 020	
TOTAL HOURS				14		

DESCRIPTION OF WORK/EQUIPMENT: Repair - CCD 020

Light back hmi welded SWS on column #104C3 & 106C3^{SE}
drilled holes from yesterday welded each to columns
used torch set up a pit truck cut the tops of 3 columns #104, 106, 107

CONTRACTOR'S SUPERVISOR:

Will
 PRINTED NAME

[Signature]
 SIGNATURE



APPLICATION FOR APPROVAL OF CONSTRUCTION CHANGE DOCUMENT - CCD CATEGORY A/B

This application is for construction changes, as defined in IR A-6, to approved contract documents. This form shall be completed by the Design Professional in General Responsible Charge of the project, in accordance with California Code of Regulations, Title 24, Part 1, Section 4-338 (c) and in compliance with DSA IR A-6.

School District/Owner: Oxnard School District	DSA File #: 56 - 22
Project Name/School: Marshall Elementary School New Classroom Building	DSA App. #: 03 - 116806

APPLICANT		
CCD Cat. <input checked="" type="checkbox"/> A / <input type="checkbox"/> B, #020	Date Submitted: 03/22/18	Attached Pages?: <input type="checkbox"/> No <input checked="" type="checkbox"/> Yes (20 pages)
For CCD Cat. B, this is a <input type="checkbox"/> voluntary submittal, <input type="checkbox"/> DSA required submittal (attach DSA notification requiring submission).		
Firm Name: CSDA Design Group	Contact Name: Michael Schoen	
Email: mschoen@csdadesigngroup.com	Phone Number: (310) 301-4772	
Address: 889 N Douglas St, Suite 100		
City: El Segundo	State: CA	Zip: 90245
<input type="checkbox"/> A DSA 301-N, DSA 301-P, or 90-Day Letter has been issued for this project.		
<input checked="" type="checkbox"/> For project currently under construction.		
<input type="checkbox"/> To obtain DSA approval of existing uncertified building(s).		

DESIGN PROFESSIONAL IN GENERAL RESPONSIBLE CHARGE	
Name of Design Professional in General Responsible Charge: Michael Schoen	
Professional License #: C-35165	Discipline: Architect

Design Professional in General Responsible Charge Statement: The attached Construction Change Documents have been examined by me for design intent and appear to meet the appropriate requirements of Title 24, California Code of Regulations and the project specifications. They are acceptable for incorporation into the construction of the project.

Signature: DESIGN PROFESSIONAL IN GENERAL RESPONSIBLE CHARGE

CHECK THIS BOX: To confirm that all CCD drawings and, when applicable, first sheet or index of calculations and specifications have been stamped and signed by the Responsible Design Professional listed on DSA 1 for this project.

Brief description of construction change (attach additional sheets if needed):
 Revised and response to CCD20_Dis1 and added detail 11/S-600 for reference only.
 Also uploaded CCD20_Dis with response to comments by EOR for reference only (03-116806_140_18_DIS1-NC Response).

List of DSA approved drawings affected by this CCD: Partial plan & det. S-212,9/S-600C,15/S-600,18/S-600

DSA USE ONLY	For business office use only	DSA Stamp
SSS <u>A. Widjaja</u> Date <u>03/31/2018</u> <u>Approved</u> Disapproved / Not Req'd FLS <input checked="" type="checkbox"/> Date _____ Approved / Disapproved <u>(Not Req'd)</u> ACS <input checked="" type="checkbox"/> Date _____ Approved / Disapproved <u>(Not Req'd)</u> Remarks: <u>DSA APPROVAL IS FOR THE CLOUDED PORTION ONLY.</u>	Date Sent _____ Return By _____ Delivery Method _____	

PCL XL Error

Subsystem:

I/O

Error:

InputReadError

Operator:

ReadImage

Position:

51194

JOB # A190 4-9-18

STUD LAYOUT FOR COLUMNS : 102C2, 125C1, 126C3

103C1, 105C1, 125C3, 125C2, 127C5, 127C3, 110C4

ADD 1/4" X 1/4" X 3" X 1/4"

ANGLES PER REF RFI :
184 REC. 4-11-18

RFI 184 REC. 4-11-18 (NOT RECD...)
PLEASE CONFIRM IF STUDS ARE
REQUIRED. HOLD DOWN SHOULD
REPLACE REQ. STUDS

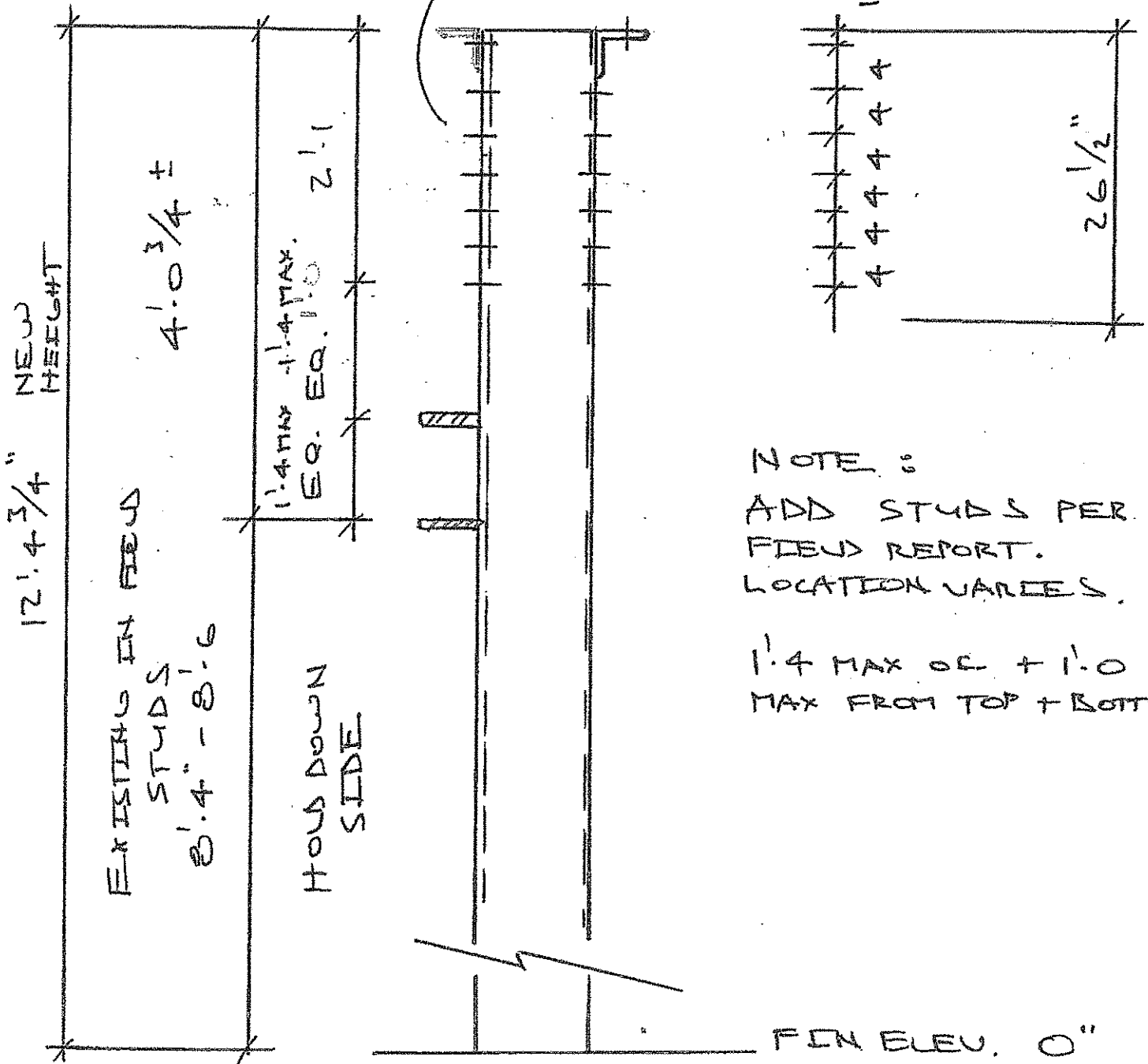

NOTE :

ADD STUDS PER
FIELD REPORT.
LOCATION VARIES.

1' 4" MAX OR + 1' 0"
MAX FROM TOP + BOTTOM

FIN ELEV. 0"

Revised for HD side column / framing clips 04/13/18 wvz

JOB # A190 4-9-18

12
PC
ANGLES

1/4 x 3/4 x 0.4"

1 1/16" Ø

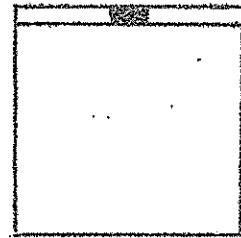
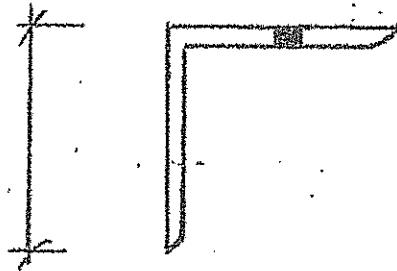
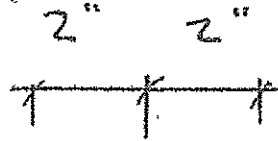

COLUMNS

- 102 C2
- 125 C1
- 126 C3
- 103 C1
- 105 C1
- 125 C3
- 125 C2
- 127 C5
- 127 C3
- 110 C4

HOLD COLUMN 127 C1 + 127 C2 PENDING CCD

BERNARD S MARSHALL E.S.

CE D 020

JOB # A190 4-9-18

10 PC ANGLES $\frac{1}{4} \times 4 \times 4 \times 0.4''$ $\frac{1}{16}'' \phi$

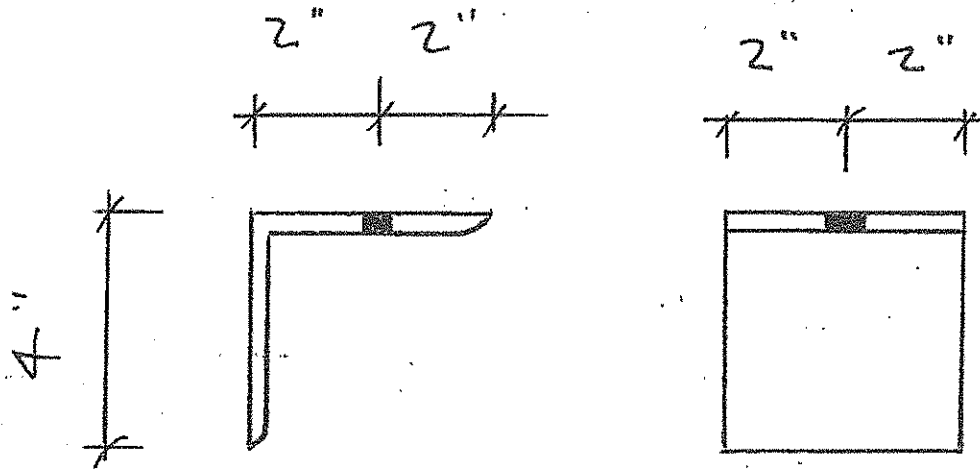

COLUMNS

102 C2
125 C1
126 C3
103 C1
105 C1
125 C3
125 C2
127 C5
127 C3
110 C4

HOLD COLUMN 127 C1 + 127 C2 PENDING CCD

2-PC RELEASED 4-13-18

IRONWORKERS LABOR RATES (STRUCTURAL STEEL)
thru 6/30/18

EFFECTIVE Jan 1 thru June 30, 2018

	STRAIGHT TIME	OVERTIME	DOUBLE TIME
WAGE RATES	40.70	61.05	81.40
VACATION	4.00	4.00	4.00
SUBTOTAL BASIC RATES	44.700	65.050	85.400
PAYROLL TAXES			
FICA (6.2%)	2.77	4.03	5.29
MEDICARE (1.45%)	0.65	0.94	1.24
FUTA (.60%)	0.27	0.39	0.51
SUTA (6.20%)	2.77	4.03	5.29
ETT (0%)	0.00	0.00	0.00
SUBTOTAL PAYROLL TAXES (14.45%)	3.69	5.37	7.05
WORKMEN'S COMP (22%)	8.59	12.45	16.31
GENERAL LIABILITY (8%)	2.97	4.64	6.08
FRINGE BENEFITS			
HEALTH & WELFARE	9.55	9.55	9.55
PENSION	13.32	13.32	13.32
TRAINING (APPRENTICESHIP)	0.72	0.72	0.72
ANNUITY	2.21	2.21	2.21
MISC	0.655	0.655	0.655
SUBTOTAL BENEFITS (67%)	26.455	26.455	26.455
ACTUAL COST PER LABOR HOUR	86.40	113.96	141.29

Note: All equipment will be charged at standard rental rates + 15%

RFI No. : 128

Project: Marshall Elementary - New 6-8 Classroom Bldg.

Date: 02-12-18

Discipline: Structural

Subject: GLB information clarification

DRAWING & SPECIFICATION REFERENCES

Drawing Sheet / Specification	Detail / Sub Section	Comments
-------------------------------	----------------------	----------

QUESTION

Design Drawings S-212 (See SK-009-C) does not indicate that there is a glulam beam over for these columns. So, our drawings for approval used detail 13/S-700 (SK-009-D). However, approver changed it to 19A/S-600F (SK-009-E). Please provide size and orientation of the glulam beam

ANSWER

Response:

The shop drawings indicated angles at the top of columns in question. The intent is not to provide additional glulam beams but rather to remove the angles because they would conflict with the bolted HD connection shown in 19A/S-600F.

Refer to 2nd Floor Framing Plan S-212 which shows HD's above the 1st floor columns. Provide holes in columns as shown in referenced detail to allow for stacking HD connections

By: DY/NC 02/12/18

Note to Contractor: In order to achieve referenced detail above, HDU's may need to be replaced by HD19 for bolting.

RESPONSE DISTRIBUTION

Company	Contact	Date Sent
C. A. Buchen Corp	Jack Furdek	2/12/2018
JF Construction Corp	John Ferrante	2/12/2018

Please review and advise Bernards, **WITHIN 7 days**, if there are any additional costs or schedule impacts associated with incorporating the RFI response with the Contract Work. (Include a brief description and rough order estimate of the change with this notification. If no response is received within 7 days, Bernards shall trust that there is no impact to your Contract Price or Schedule.

Question Initiated By: Jack Furdek - C. A. Buchen Corp - Author Number: 17

Submitted By: Jack Furdek - C. A. Buchen Corp



REQUEST FOR INFORMATION

RFI No.: 128

To: Jose Arche
Company: CSDA Design Group
Project: Marshall Elementary - New 6-8 Classroom Bldg.
Subject: GLB information clarification

Date: 02-06-18
Discipline: Structural

Response Requested By: 02-13-2018

DRAWINGS & SPECIFICATION REFERENCES

Drawing Sheet / Specification	Detail / Sub Section	Comments
-------------------------------	----------------------	----------

QUESTION

Design Drawings S-212 (See SK-009-C) does not indicate that there is a glulam beam over for these columns. So, our drawings for approval used detail 13/S-700 (SK-009-D). However, approver changed it to 19A/S-600F (SK-009-E). Please provide size and orientation of the glulam beam.

ANSWER

NC Response:

The shop drawings indicated angles at the top of columns in question. The intent is not to provide additional glulam beams but rather to remove the angles because they would conflict with the bolted HD connection shown in 19A/S-600F.

Refer to 2nd Floor Framing Plan S-212 which shows HD's above the 1st floor columns. Provide holes in columns as shown in referenced detail to allow for stacking HD connections.

By: DY/NC 02/12/18

Note to Contractor: In order to achieve referenced detail above, HDU's may need to be replaced by HD19 for bolting.

Response Provided By: _____

Name	Company	Date
------	---------	------

Question Initiated By: Jack Furdek - C. A. Buchen Corp - Author Number: 17

Submitted By: Jack Furdek - C. A. Buchen Corp

SK-009-B
REF: E102

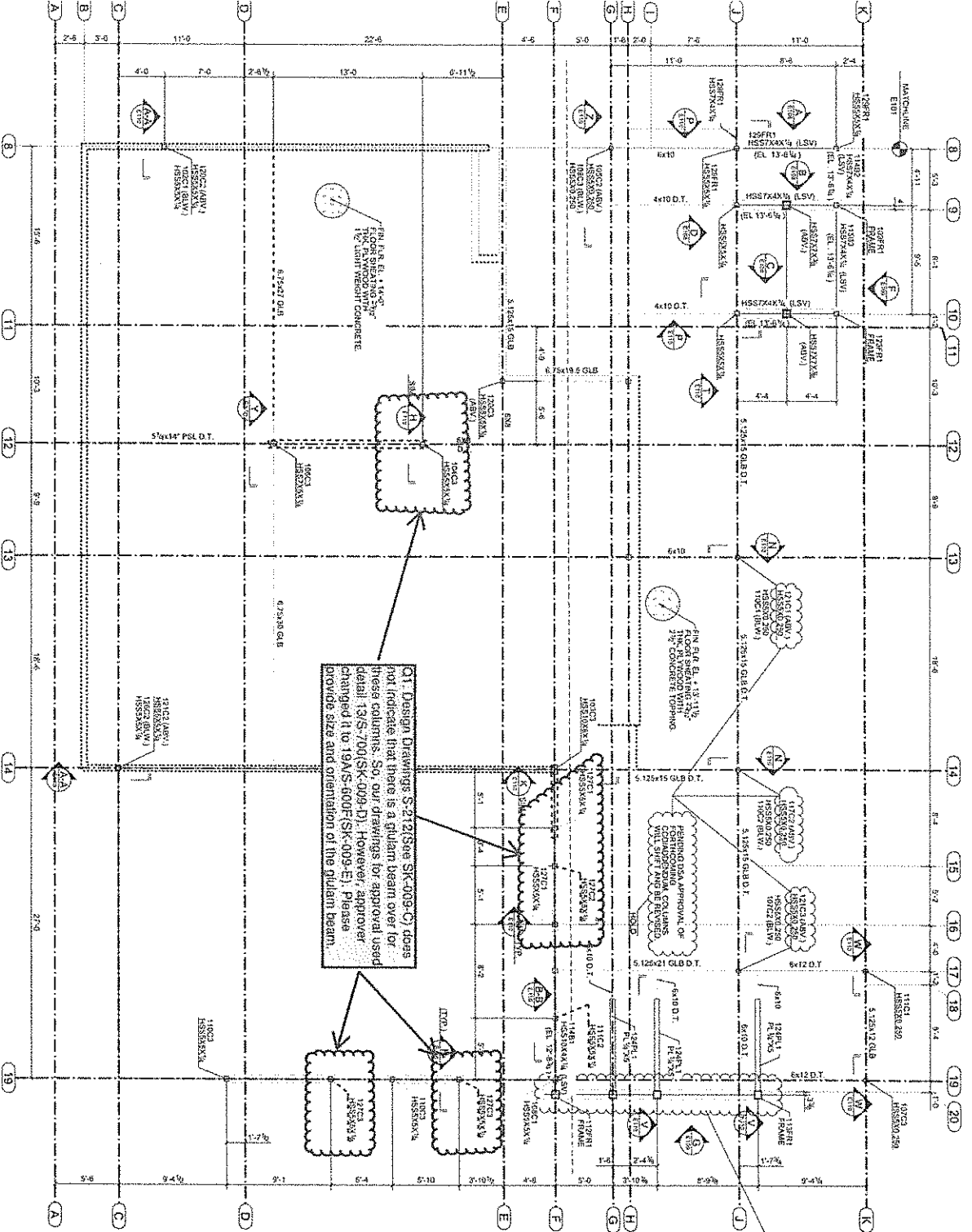

NOTES:
1. REFER TO GENERAL NOTES AND ELEVATIONS SHEETS FOR FINISHING CONDITIONS.
2. REFER TO GENERAL NOTES AND ELEVATIONS SHEETS FOR FINISHING CONDITIONS.
3. REFER TO GENERAL NOTES AND ELEVATIONS SHEETS FOR FINISHING CONDITIONS.
4. REFER TO GENERAL NOTES AND ELEVATIONS SHEETS FOR FINISHING CONDITIONS.

PARTIAL 2ND FLOOR FRAMING PLAN
1. REFER TO ELEV. 1 FOR FINISHING CONDITIONS.
2. TOP OF STEEL ELEV. = SEE PLAN
3. REF. DWG. S-212



PLAN NORTH

G1 Design Drawings S-212(Sec SK-009-C) does not indicate that there is a gullian beam over for these columns. So, our drawings for approved used detail 13/S-700(SK-009-D). However, approval changed it to 19/S-800F(SK-009-E). Please provide size and orientation of the gullian beam.

REQUIRE DETAIL APPROVAL OF THESE COLUMNS WILL SHIP AND BE REVERSED

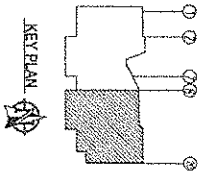

REVISION		DATE		BY		CHECKED	
1	ISSUED	11/15/20	11/15/20	11/15/20	11/15/20	11/15/20	11/15/20
2	REVISED	11/15/20	11/15/20	11/15/20	11/15/20	11/15/20	11/15/20
3	REVISED	11/15/20	11/15/20	11/15/20	11/15/20	11/15/20	11/15/20
4	REVISED	11/15/20	11/15/20	11/15/20	11/15/20	11/15/20	11/15/20
5	REVISED	11/15/20	11/15/20	11/15/20	11/15/20	11/15/20	11/15/20

cabco C.A. Birklin Corp
QUALITY CONTROL
SOLUTIONS

MANUFACTURING SECTION
C.A. BIRKLIN CORP
11111 W. 111TH AVENUE
DENVER, CO 80233
TEL: 303.440.1111
WWW.CABCO.COM

PROJECT: [REDACTED]
DRAWING: [REDACTED]
DATE: 11/15/20
BY: [REDACTED]
CHECKED: [REDACTED]
SCALE: AS SHOWN
SHEET: E102 OF 102

1 2ND FLOOR FRAMING PLAN

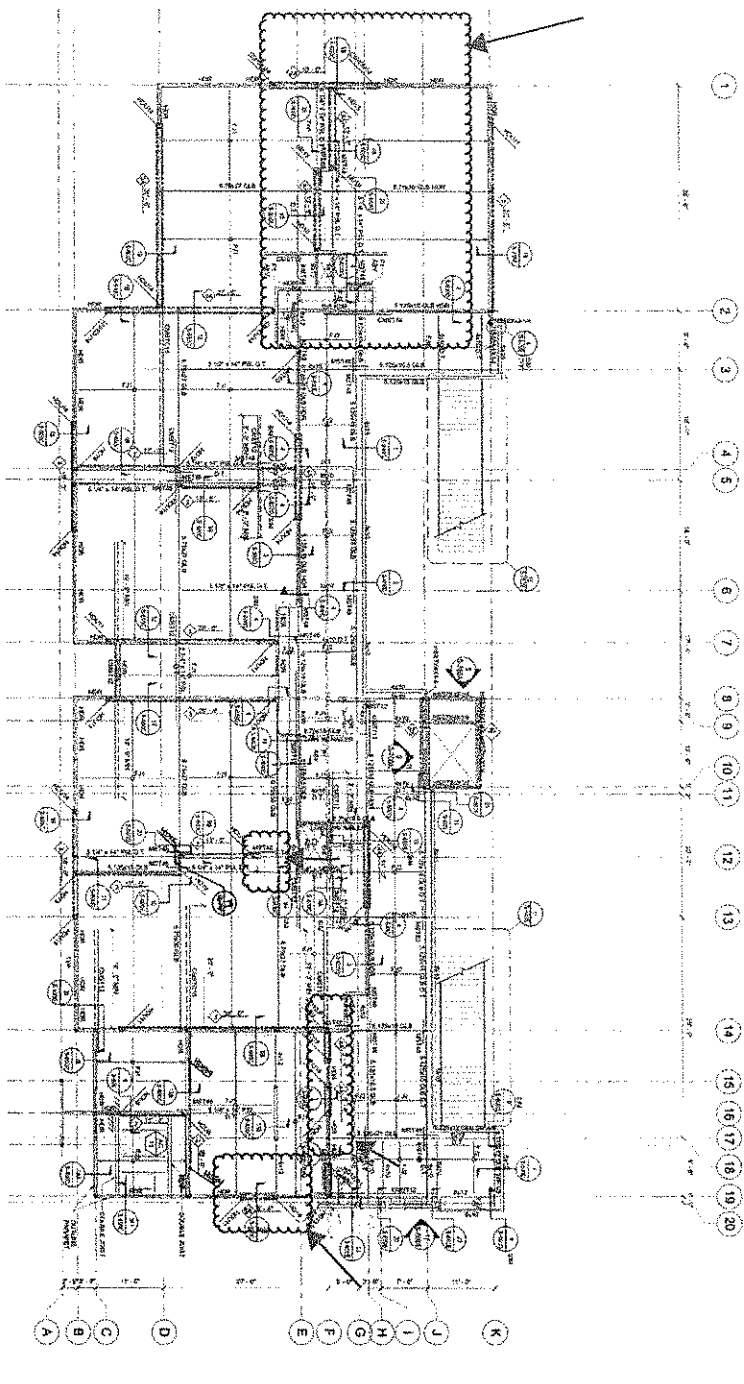

SK-009-C
REF: S-212

1. SEE SHEET SK-009-B FOR 1ST FLOOR FRAMING PLAN.
2. SEE SHEET SK-009-D FOR 3RD FLOOR FRAMING PLAN.
3. SEE SHEET SK-009-E FOR 4TH FLOOR FRAMING PLAN.
4. SEE SHEET SK-009-F FOR 5TH FLOOR FRAMING PLAN.
5. SEE SHEET SK-009-G FOR 6TH FLOOR FRAMING PLAN.
6. SEE SHEET SK-009-H FOR 7TH FLOOR FRAMING PLAN.
7. SEE SHEET SK-009-I FOR 8TH FLOOR FRAMING PLAN.
8. SEE SHEET SK-009-J FOR 9TH FLOOR FRAMING PLAN.
9. SEE SHEET SK-009-K FOR 10TH FLOOR FRAMING PLAN.
10. SEE SHEET SK-009-L FOR 11TH FLOOR FRAMING PLAN.
11. SEE SHEET SK-009-M FOR 12TH FLOOR FRAMING PLAN.
12. SEE SHEET SK-009-N FOR 13TH FLOOR FRAMING PLAN.
13. SEE SHEET SK-009-O FOR 14TH FLOOR FRAMING PLAN.
14. SEE SHEET SK-009-P FOR 15TH FLOOR FRAMING PLAN.
15. SEE SHEET SK-009-Q FOR 16TH FLOOR FRAMING PLAN.
16. SEE SHEET SK-009-R FOR 17TH FLOOR FRAMING PLAN.
17. SEE SHEET SK-009-S FOR 18TH FLOOR FRAMING PLAN.
18. SEE SHEET SK-009-T FOR 19TH FLOOR FRAMING PLAN.
19. SEE SHEET SK-009-U FOR 20TH FLOOR FRAMING PLAN.
20. SEE SHEET SK-009-V FOR 21ST FLOOR FRAMING PLAN.

CSSDA DESIGN GROUP
 1000 14th Ave, Suite 8
 Denver, CO 80202
 303.733.8200
 www.cssdadesign.com



WILLIAM H. B.
 REGISTERED PROFESSIONAL ENGINEER
 STATE OF COLORADO
 No. 10000

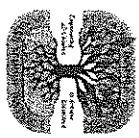

ONWARD SCHOOL DISTRICT
 1000 14th Ave
 Denver, CO 80202
 303.447.7414
 www.onward.net

MARSHALL NEW CLASSROOM BUILDING
 Local Special Use

NO.	DESCRIPTION	DATE
1	DESIGN/REVISIONS	04/11
2	DESIGN	05/11
3	ISSUE FOR PERMIT	05/11
4	ISSUE FOR CONSTRUCTION	05/11
5	ISSUE FOR OCCUPANCY	05/11

2ND FLOOR FRAMING PLAN

S-212

SK-009-D
 REF: S-700



MISHAAN SAMSIERNAM
 ENGINEER
 1000 S. GARDEN ST. SUITE 100
 ANAHEIM, CA 92805
 TEL: 714.771.1111
 WWW.MISHAANSAMSIERNAM.COM

PROJECT INFORMATION

PROJECT NO.	SK-009-D
DATE	11/11/2014
PROJECT NAME	MARSHALL NEW CLASSROOM BUILDING
PROJECT LOCATION	OXFORD DISTRICT
CLIENT	OXFORD DISTRICT
DESIGNED BY	MISHAAN SAMSIERNAM
CHECKED BY	MISHAAN SAMSIERNAM
DATE	11/11/2014

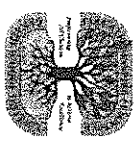

OXFORD SCHOOL DISTRICT
 20111 CHINA
 ANAHEIM, CA 92816
 714.771.1111
 WWW.OXFORDSDISTRICT.COM

MARSHALL NEW CLASSROOM BUILDING
 OXFORD DISTRICT

NO. IDENTIFICATION DATE

1	ISSUANCE	ISSUED	11/11/2014
2	REVISION	REVISED	11/11/2014
3	REVISION	REVISED	11/11/2014
4	REVISION	REVISED	11/11/2014
5	REVISION	REVISED	11/11/2014
6	REVISION	REVISED	11/11/2014
7	REVISION	REVISED	11/11/2014
8	REVISION	REVISED	11/11/2014
9	REVISION	REVISED	11/11/2014
10	REVISION	REVISED	11/11/2014

S-700
 FRAMING DETAILS

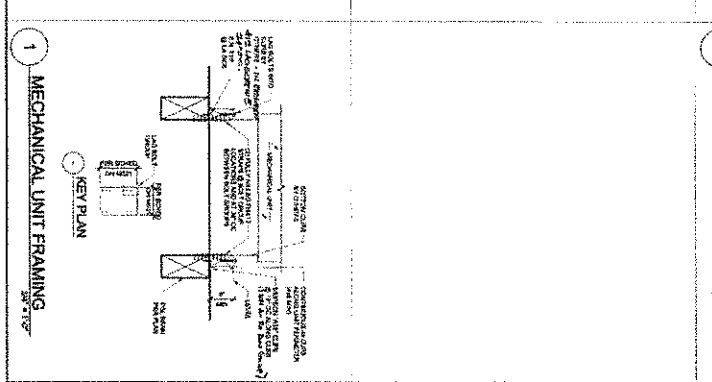
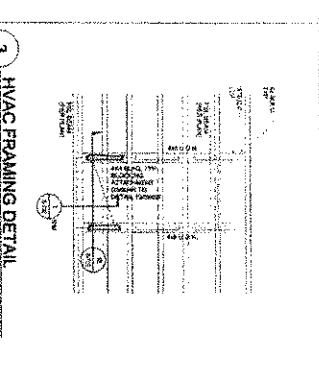
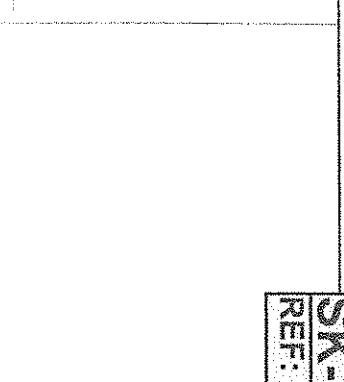
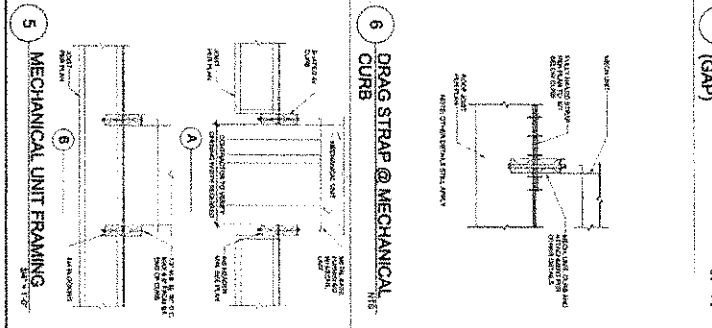
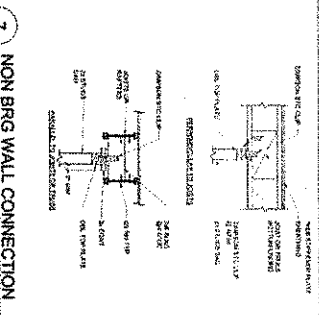
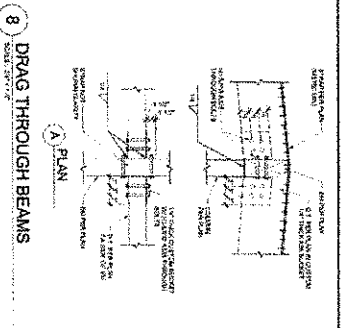
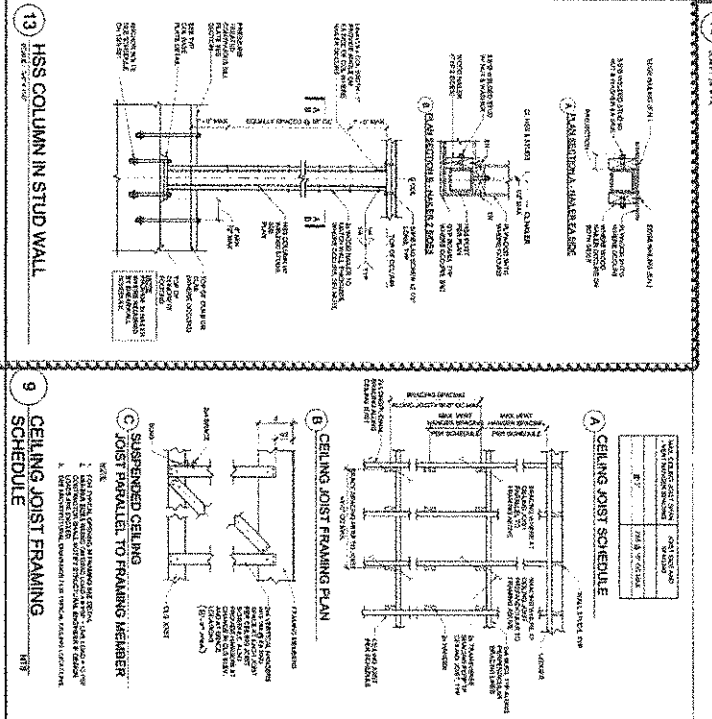
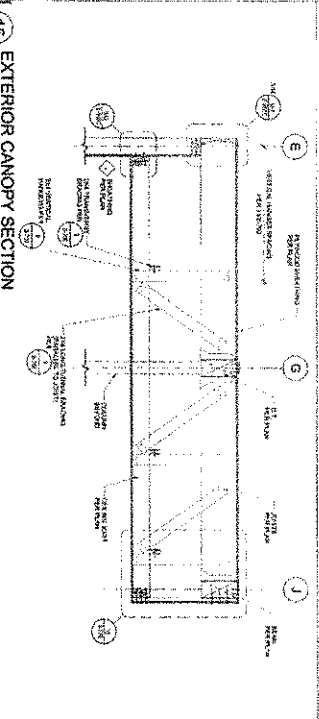
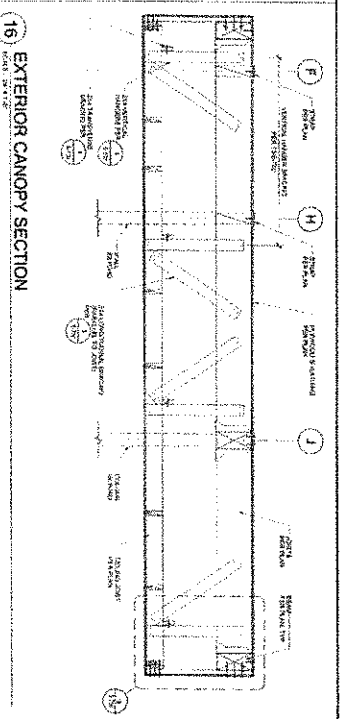

S-700
 FRAMING DETAILS

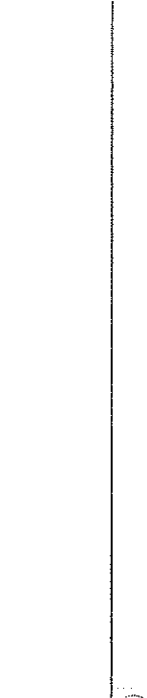
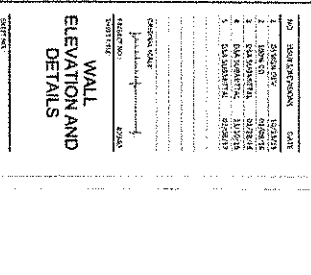
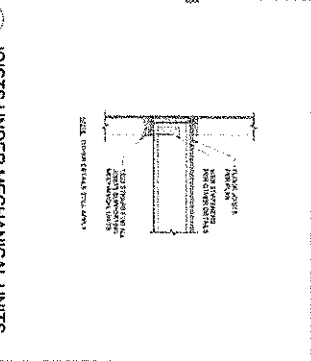
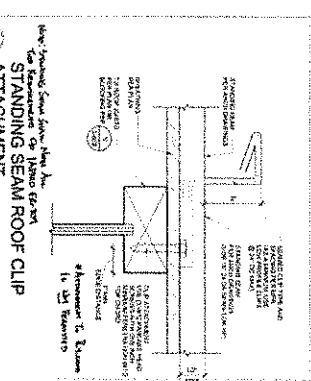
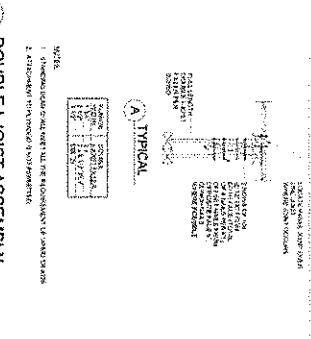
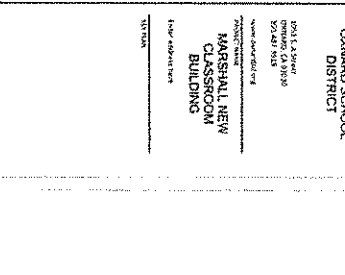
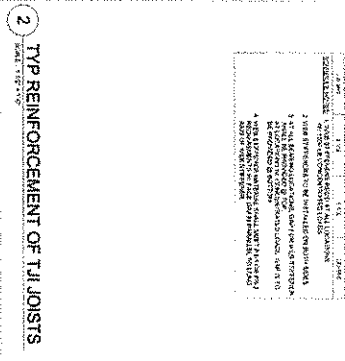
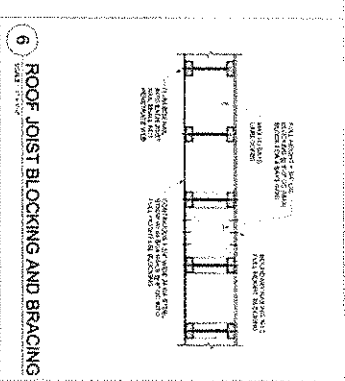
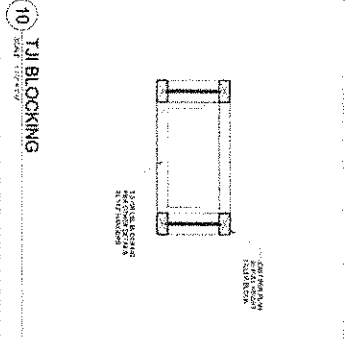
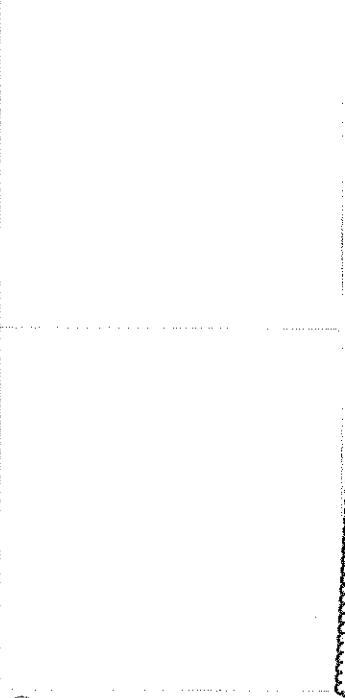
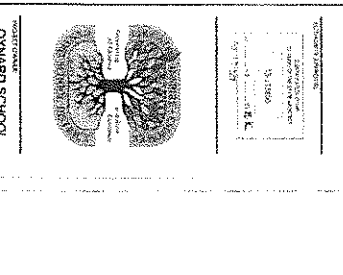
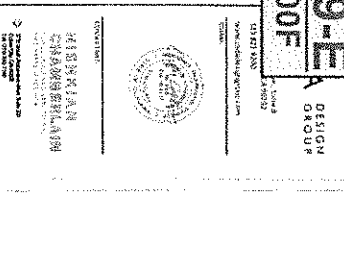
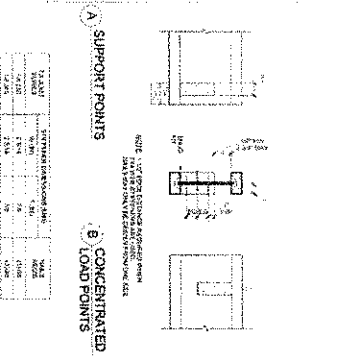
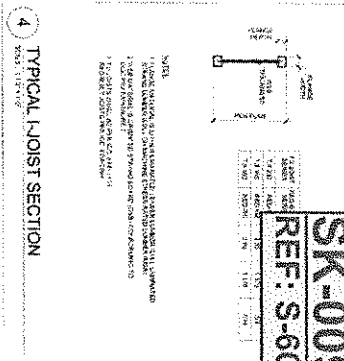
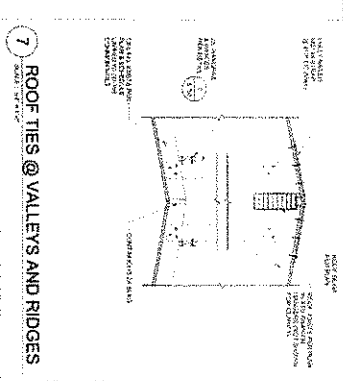
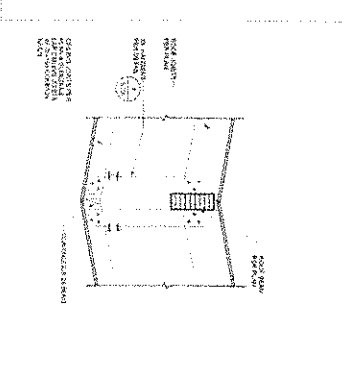
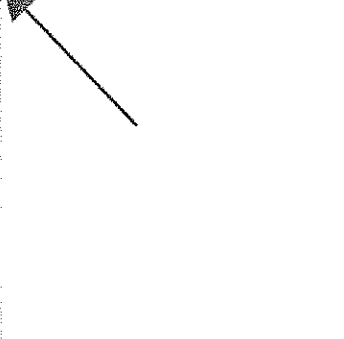
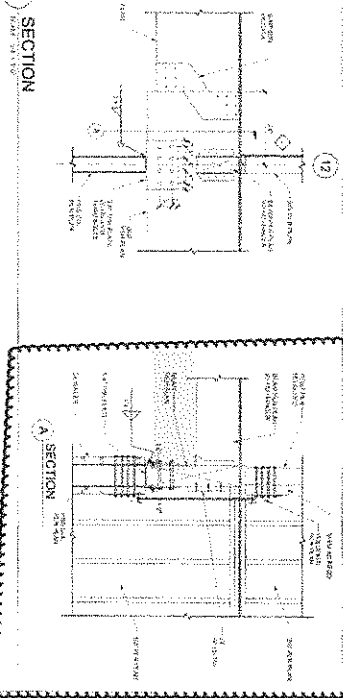
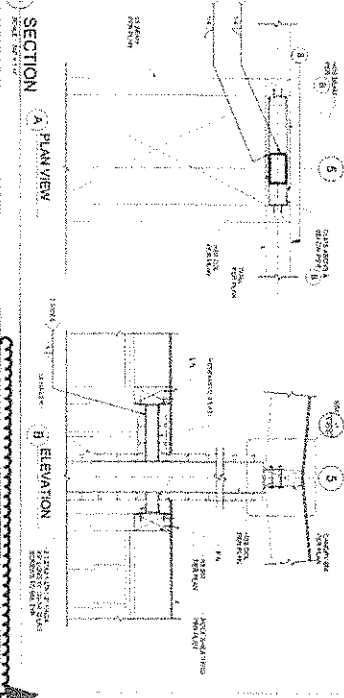

REVISIONS

NO.	DATE	DESCRIPTION
1	10/15/10	ISSUED FOR PERMIT
2	10/20/10	REVISED PER COMMENTS
3	11/01/10	REVISED PER COMMENTS
4	11/15/10	REVISED PER COMMENTS
5	12/01/10	REVISED PER COMMENTS
6	12/15/10	REVISED PER COMMENTS
7	01/01/11	REVISED PER COMMENTS
8	01/15/11	REVISED PER COMMENTS
9	02/01/11	REVISED PER COMMENTS
10	02/15/11	REVISED PER COMMENTS
11	03/01/11	REVISED PER COMMENTS
12	03/15/11	REVISED PER COMMENTS
13	04/01/11	REVISED PER COMMENTS
14	04/15/11	REVISED PER COMMENTS
15	05/01/11	REVISED PER COMMENTS
16	05/15/11	REVISED PER COMMENTS
17	06/01/11	REVISED PER COMMENTS
18	06/15/11	REVISED PER COMMENTS
19	07/01/11	REVISED PER COMMENTS
20	07/15/11	REVISED PER COMMENTS
21	08/01/11	REVISED PER COMMENTS
22	08/15/11	REVISED PER COMMENTS
23	09/01/11	REVISED PER COMMENTS
24	09/15/11	REVISED PER COMMENTS
25	10/01/11	REVISED PER COMMENTS
26	10/15/11	REVISED PER COMMENTS
27	11/01/11	REVISED PER COMMENTS
28	11/15/11	REVISED PER COMMENTS
29	12/01/11	REVISED PER COMMENTS
30	12/15/11	REVISED PER COMMENTS

SK-009-E
REF: S-600F
DESIGN GROUP

NOTES:
1. REFER TO THE GENERAL NOTES FOR THE PROJECT FOR THE LATEST REVISIONS.
2. THE JOIST SPACING SHALL BE 24" ON CENTER UNLESS OTHERWISE NOTED.
3. THE JOIST SHALL BE 2X12 S4S UNLESS OTHERWISE NOTED.
4. THE JOIST SHALL BE 2X12 S4S UNLESS OTHERWISE NOTED.

TABLE 1: JOIST SPACING AND BRACING

JOIST SIZE	SPACING	BRACING
2X12 S4S	24" OC	1X4 BRACING @ 4' ON CENTER
2X10 S4S	24" OC	1X4 BRACING @ 4' ON CENTER
2X8 S4S	24" OC	1X4 BRACING @ 4' ON CENTER
2X6 S4S	24" OC	1X4 BRACING @ 4' ON CENTER
2X4 S4S	24" OC	1X4 BRACING @ 4' ON CENTER

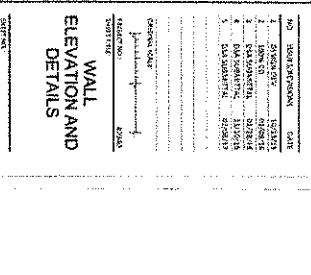
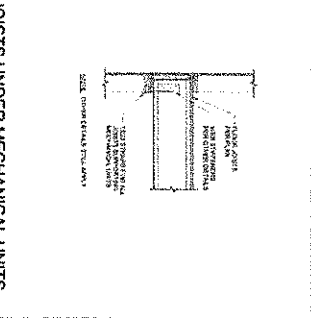
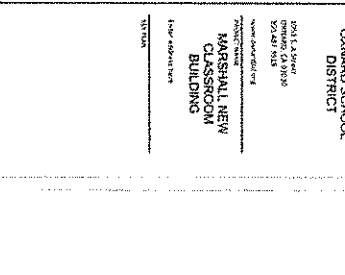
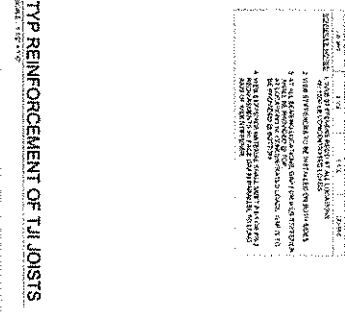
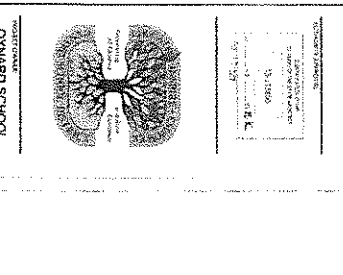



REQUEST FOR INFORMATION FOR SUBCONTRACTOR ACTION

RFI No. : 128 R

Project: Marshall Elementary - New 6-8 Classroom Bldg.

Date: 02-13-18

Discipline: Structural

Subject: GLB information clarification

DRAWING & SPECIFICATION REFERENCES

Drawing Sheet / Specification

Detail / Sub Section

Comments

QUESTION

RFI No. : 128 R

Project: Marshall Elementary - New 6-8 Classroom Bldg.

Date: 02-13-18

Discipline: Structural

Subject: GLB information clarification

Per RFI 128 Response, please confirm / clarify the following:

- 1) ¼"x 4"x 4" angle to be removed from these columns and holes added per attached sketch. Please approve sketch
- 2) See list of columns affected by RFI 128, several of which were not corrected on the shop drawing submittals. Please confirm the list below.

Columns:

"104C3 Was left off original list"

102C2

125C1

106C2 no connection for HD shown on submittal?

126C3 no connection for HD shown on submittal?

103C1

105C1

125C3

125C2 no correction for HD shown on submittal?

127C3 One column only GL 19 and 3' 10" south of GL "E".

127C3SNC Detailing. One column north of GL "D" & 19 is not an HD column.

110C3 One column only GL 19 and 9' 8 ½" south of GL "E".

127C1 Two columns

127C2

Material on hold pending RFI 127 review:

103C2

114B3

Confirm buckets and orientation:

107C1

107C2

107C3

Checker could not locate beams at elevator ref. sheet E107:

115B1

115B2

Please verify studs on sheet 115.

Verify bottom plate connection for:

119C3

120C3



**REQUEST FOR INFORMATION
FOR SUBCONTRACTOR ACTION**

RFI No. : 128 R

Project: Marshall Elementary - New 6-8 Classroom Bldg.

Date: 02-13-18

Discipline: Structural

Subject: GLB information clarification

ANSWER

Response:

Sketch appears to be in general conformance with contract documents. Please note that some locations require (2) HD's

See the attachment for confirmation on various column locations

Responded by David Yool on 02/13/18

RESPONSE DISTRIBUTION

Company	Contact	Date Sent
---------	---------	-----------

Please review and advise Bernards, **WITHIN 7 days**, if there are any additional costs or schedule impacts associated with incorporating the RFI response with the Contract Work. (Include a brief description and rough order estimate of the change with this notification. If no response is received within 7 days, Bernards shall trust that there is no impact to your Contract Price or Schedule.

Question Initiated By: Jack Furdek - C. A. Buchen Corp - Author Number: 18

Submitted By: Jack Furdek - C. A. Buchen Corp

Project: Marshall Elementary - New 6-8 Classroom Bldg.

REQUEST FOR INFORMATION

Job No. 1641.

3 of 3

Report Date: 2/22/2018



CONTINGENCY ALLOCATION REQUEST

CAR No. 41 R1

Date: 7/30/2018

Project: Marshall Elementary - New 6-8 Classroom Bldg.

DESCRIPTION OF WORK

Change 2 tier locker to 4 tier lockers

SUMMARY OF ALLOCATIONS

Item Description	Company	Amount Requested
Subcontract Costs		
Per RFI 133 change in layout and locker count in the boys and girls locker room. 40 for girls and 40 for boys; 4 Tier each w/8 ADA lockers. Revised Response by Jose Arche/CSDA on 05/4/18	Inland Empire Architectural Specialties	18,388
	Subtotal:	18,388
Total Change Order Request Amount:		18,388

ACKNOWLEDGEMENT

Oxnard School District

Bernards Bros. Inc.

Signature

Signature

Printed Name & Title

Printed Name & Title

Date

Date

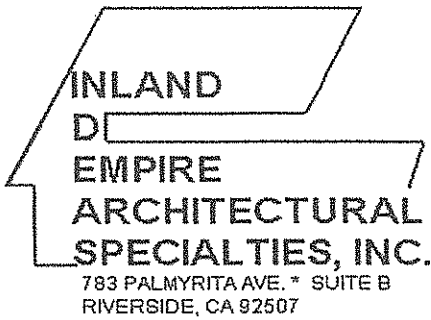

QUOTATION# 170606206

(951) 781-0700 * Fax (951) 781-9815

License # 461106

Addenda Noted: N/A

Date: 6/6/2017

DIR# 1000003436 SBE #1078221 MBE #9GN00056

Name of Job: Marshall Elementary School

Location: Oxnard

To: General Contractor

Attn: Estimating

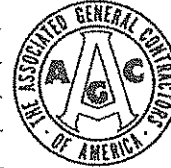

"It's Good Business to do Business with an AGC Member"

Fire Extinguishers	<p>Quote is for 16 non-fire rated extinguisher boxes and 2 fire rate boxes as per specs and plans Total of 18 fire extinguishers and extinguisher boxes.</p> <p style="text-align: right;"><u>Furnished, taxed, and Installed: \$5,300.00</u></p>
Lockers and Benches	<p>Due to quantity conflicts on sheet no. A-411 with locker calculations and drawing. This quote is for what is on the drawing and specs section 10505 which is 64 frames of DeBourgh 12x12x24 three tier lockers with 2 ADA benches 20x48. Any changes will require a price adjustment.</p> <p style="text-align: right;"><u>Furnished, taxed, and Installed: \$46,600.00</u></p>

Notes:

Any changes will result in price adjustment.

***EXCLUDES:** All Pipe/Trap Wrap; Blocking/Backing/Caulking of any kind, Demo.; Final Cleaning, Jobsite security, Plumbing; Electrical; Mock STANDARD ups; Non-Normal Working Hours; Waiver of Subrogation.

Terms of Payment: Per Contract with Pre Lim info
 Delivery: ADVISE
 FOB Point: DESTINATION

Proposed Method of Shipment: Truck
 Prepaid: XX

The above prices are firm for 30 Days. Terms of payment are Net 30 upon progress payment. Any alteration or deviation from above referenced specifications involving extra costs, will be executed only upon written orders, and will become an extra charge over and above quoted prices. Prices shall be increased without notice if necessary to compensate for any Federal, State or Municipal Tax or Law hereafter adopted or not listed in this quotation. Delivery is contingent upon Strikes, Fire or causes beyond our control.

Quoted By: Lalo Enriquez Title: Estimator Date: 6/6/2017

Approved By: _____ Print Name: _____ Date: _____

QUOTATION #180513766-1

(951) 781-0700 * Fax (951) 781-9815

License # 461106

Addenda Noted: N/A

Date: 2/27/2019

DIR# 1000003436 SBE #1078221 MBE #9GN00056

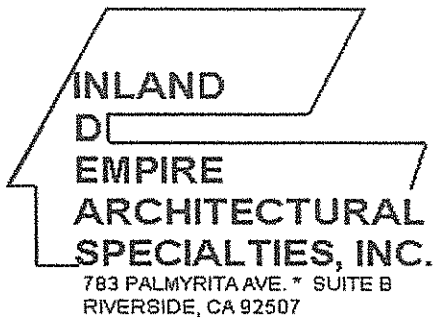

Name of Job: Marshall Elementary School

Location: 1051 S. A Street, Oxnard, CA 93030

To: Bernards

Attn: Sahithya Mavillapalli (SMavillapalli@bernards.com)



"It's Good Business to
do Business with an
AGC Member"

Lockers and Benches PER RFI 133	<p>(80) DeBourgh Iron Angle 12x12x18 4-teir Lockers (320 Openings) with recessed cup, sloped tops, diamond perforation, 5 knuckle hinges, and (2) 20"x48" ADA benches. Any changes will require a price adjustment.</p> <p>Notes: Original quote #170606206 had (64) frames 3-tier which are being removed and replaced by lockers noted above.</p> <p style="text-align: right;">Furnished, taxed, and Installed: \$64,988.00</p>
	<p style="text-align: center;">Furnished, taxed, and Installed:</p>
<p>Notes:</p> <p>Excludes: Locks, Bases and any other option not noted above.</p>	

***EXCLUDES:** All Pipe/Trap Wrap; Blocking/Backing/Caulking of any kind, Demo.; Final Cleaning, Jobsite security, Plumbing; Electrical; Mock STANDARD ups; Non-Normal Working Hours; Union Labor

Terms of Payment: 50% Deposit, Net 30 upon completion
Delivery: ADVISE
FOB Point: DESTINATION

Proposed Method of Shipment: Truck
Prepaid: XX

The above prices are firm for 30 Days. Terms of payment are Net 30 upon progress payment. Any alteration or deviation from above referenced specifications involving extra costs, will be executed only upon written orders, and will become an extra charge over and above quoted prices. Prices shall be increased without notice if necessary to compensate for any Federal, State or Municipal Tax or Law hereafter adopted or not listed in this quotation. Delivery is contingent upon Strikes, Fire or causes beyond our control.

Quoted By: Jose Flores Title: Estimator Date: 2/27/2019

Approved By: _____ Print Name: _____ Date: _____



**REQUEST FOR INFORMATION
FOR SUBCONTRACTOR ACTION**

RFI No. : 133

Project: Marshall Elementary - New 6-8 Classroom Bldg.

Date: 05-07-18

Discipline: Architectural

Subject: Restroom Configuration

DRAWING & SPECIFICATION REFERENCES

Drawing Sheet / Specification	Detail / Sub Section	Comments
A-411		
A-530	Detail -13	

QUESTION

1. Please confirm that the locker frame count should be considered from the enlarged floor plan sheet A-411
2. Please confirm on Detail 13/A-530 that the concrete curb is changed from 6" to 4" and tooled radius is straight 90 degrees.
3. Also, Please provide the layout and dimensions along with curb details including the height for lockers and curbs in Restroom/Changing room

ANSWER

Response:

1. 40 for girls and 40 for boys; 4 Tier each w/8 ADA lockers.
Revised Response by Jose Arche/CSDA on 05/4/18

2. Curb to be 4" with a 90 degree edge

Responded by Jose Arche on 02/21/18

3. Sketch was provide at construction meeting and walked

will follow with the CCD 023 with the floor plan that will summit to DSA for access review

Reponded by Jose Arche on 04/13/18

RESPONSE DISTRIBUTION

Company	Contact	Date Sent
Inland Empire Architectural Specialties	Charles Lozito	5/7/2018



**REQUEST FOR INFORMATION
FOR SUBCONTRACTOR ACTION**

RFI No. : 133

Project: Marshall Elementary - New 6-8 Classroom Bldg.

Date: 05-07-18

Discipline: Architectural

Subject: Restroom Configuration

Please review and advise Bernards, **WITHIN 7 days**, if there are any additional costs or schedule impacts associated with incorporating the RFI response with the Contract Work. (Include a brief description and rough order estimate of the change with this notification. If no response is received within 7 days, Bernards shall trust that there is no impact to your Contract Price or Schedule.

Question Initiated By: Rebecca Miller - Bernards

Submitted By: Rebecca Miller - Bernards

Project: Marshall Elementary - New 6-8 Classroom Bldg.

REQUEST FOR INFORMATION

Job No. 1641.

2 of 2

Report Date: 5/7/2018



REQUEST FOR INFORMATION FOR SUBCONTRACTOR ACTION

RFI No. : 133

Project: Marshall Elementary - New 6-8 Classroom Bldg.

Date: 04-13-18

Discipline: Architectural

Subject: Restroom Configuration

DRAWING & SPECIFICATION REFERENCES

Drawing Sheet / Specification	Detail / Sub Section	Comments
A-411		
A-530	Detail -13	

QUESTION

1. Please confirm that the locker frame count should be considered from the enlarged floor plan sheet A-411
2. Please confirm on Detail 13/A-530 that the concrete curb is changed from 6" to 4" and tooled radius is straight 90 degrees.
3. Also, Please provide the layout and dimensions along with curb details including the height for lockers and curbs in Restroom/Changing room

ANSWER

Response:

40 girls & 40 boys

1. ~~31 for Boys, 31 for girls, 3 tiers each~~ 4 TIERS EACH W/ 8 ADA LOCKERS.

2. Curb to be 4" with a 90 degree edge

Responded by Jose Arche on 02/21/18

3. Sketch was provide at construction meeting and walked

will follow with the CCD 023 with the floor plan that will summit to DSA for access review

Reponded by Jose Arche on 04/13/18

CSDA Jose Arche 05/4/18

RESPONSE DISTRIBUTION

Company	Contact	Date Sent



**REQUEST FOR INFORMATION
FOR SUBCONTRACTOR ACTION**

RFI No. : 133

Project: Marshall Elementary - New 6-8 Classroom Bldg.

Date: 04-13-18

Discipline: Architectural

Subject: Restroom Configuration

Please review and advise Bernards, **WITHIN 7 days**, if there are any additional costs or schedule impacts associated with incorporating the RFI response with the Contract Work. (Include a brief description and rough order estimate of the change with this notification. If no response is received within 7 days, Bernards shall trust that there is no impact to your Contract Price or Schedule.

Question Initiated By: Rebecca Miller - Bernards

Submitted By: Rebecca Miller - Bernards

Project: Marshall Elementary - New 6-8 Classroom Bldg.

Job No. 1641.

2 of 2

REQUEST FOR INFORMATION

Report Date: 4/13/2018



REQUEST FOR INFORMATION

RFI No.: 133R

To: Jose Arche
Company: CSDA Design Group
Project: Marshall Elementary - New 6-8 Classroom Bldg.
Subject: Locker frames Count and Curb Radius

Date: 02-21-18
Discipline: Architectural

Response Requested By: 02-28-2018

DRAWINGS & SPECIFICATION REFERENCES

Drawing Sheet / Specification	Detail / Sub Section	Comments
A-411		
A-530	Detail -13	

QUESTION

1. Please confirm that the locker frame count should be considered from the enlarged floor plan sheet A-411
2. Please confirm on Detail 13/A-530 that the concrete curb is changed from 6" to 4" and tooled radius is straight 90 degrees.
3. Also, Please provide the layout and dimensions along with curb details including the height for lockers and curbs in Restroom/Changing room

ANSWER

Questions 1 & 2 have been answer on 02/21/18

3. Sketch was provide at a construction meeting and walked.
Will follow with the CCD 023 with the floor plan that will submit to DSA for access review.

Response Provided By: Jose Arche CSDA 04-13-18
 Name Company Date

Question Initiated By: Rebecca Miller - Bernards
Submitted By: Rebecca Miller - Bernards

14

16

19

20

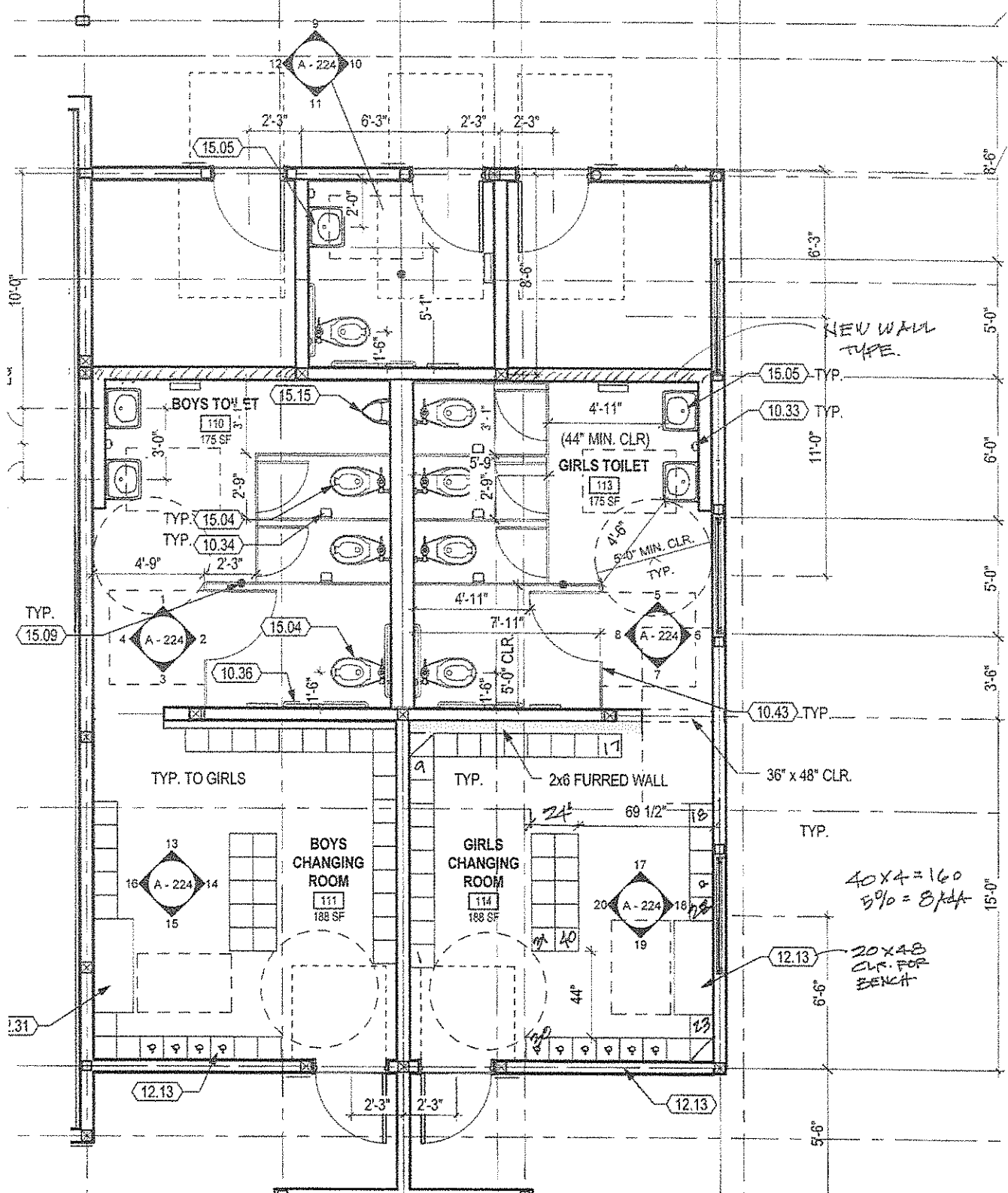

NEW WALL TYPE.

40x4 = 160
5% = 8 ft

20x48 CLR. FOR BENCH

F.P.
AC. 1/4" = 1'-0"

3/28/18

15

17 18

20



CONTINGENCY ALLOCATION REQUEST

Project: Marshall Elementary - New 6-8 Classroom Bldg.

CAR No. 63 R0

Date: 11/8/2018

DESCRIPTION OF WORK

Per RFI 257 new 6x6 post with ECCQ66

SUMMARY OF ALLOCATIONS

Item Description	Company	Amount Requested
Subcontract Costs		
Per RFI 257 new 6x6 post with ECCQ66	JF Construction Corp	712
	Subtotal:	712
Total Change Order Request Amount		712

ACKNOWLEDGEMENT

Oxnard School District

Bernards Bros. Inc.

Signature

Jose Arche, CSDA

Printed Name & Title

01-14-19

Date

Signature

Rebecca Miller, Project Manager

Printed Name & Title

1/19/19

Date



HOURLY LABOR COST RATES

Sub/Contractor: JE Construction Corp Trade: Rough Carpentry
 Date: 2/14/2018 Classification: 6100
 Project: Marshall E.S.
 Rate Effective Through: July 1, 2018 Union: Non Union:

	Straight Time	Time & 1/2	Double Time
A. HOURLY TAXABLE WAGE COSTS			
Hourly Wage	\$ 42.41	\$ 63.62	\$ 84.82
Vacation & Holiday Accrual	\$ 0.19	\$ 0.19	\$ 0.19
Hourly Taxable Wage Costs Subtotal	\$ 42.60	\$ 63.81	\$ 85.01
B. HOURLY PAYROLL TAX & INSURANCE			
Social Security	\$ 3.01	\$ 4.37	\$ 5.64
Medicare	\$ 0.70	\$ 1.01	\$ 1.32
FUI	\$ 0.29	\$ 0.42	\$ 0.55
SUI	\$ 3.01	\$ 4.32	\$ 5.64
Workers Compensation Insurance	\$ 0.97	\$ 0.97	\$ 0.97
General Liability Insurance (If Applicable)	\$ -	\$ -	\$ -
Hourly Payroll Tax & Insurance Subtotal	\$ 7.98	\$ 10.04	\$ 12.12
C. HOURLY BENEFITS			
Health & Welfare (or equivalent)	\$ 7.50	\$ 7.50	\$ 7.50
Pension & Retirement (or equivalent)	\$ 4.91	\$ 4.91	\$ 4.91
Training (or equivalent)	\$ 1.01	\$ 1.01	\$ 1.01
Hourly Benefits Subtotal	\$ 13.42	\$ 13.42	\$ 13.42
TOTAL HOURLY LABOR COST RATE (A+B+C)	\$ 78.00	\$ 107.27	\$ 126.55

Factors NOT allowed in the above hourly labor cost rates:

- | | |
|--------------------------------------|--------------------------------|
| 1. Overhead | 5. Consumables |
| 2. Profit | 6. Bonus or incentive payments |
| 3. Vehicle & transportation expenses | 7. Communications |
| 4. Small tools | 8. Supervision |



**REQUEST FOR INFORMATION
FOR SUBCONTRACTOR ACTION**

RFI No. : 257

Project: Marshall Elementary - New 6-8 Classroom Bldg.

Date: 08-24-18

Discipline: Structural

Subject: Clarification of Column/Post at GL 20.2/J.2

DRAWING & SPECIFICATION REFERENCES

Drawing Sheet / Specification	Detail / Sub Section	Comments
S-211		
S-212		

QUESTION

No description is provided for the post or column referenced on page2 of this document.

SUGGESTION

Please clarify

ANSWER

Response:

Refer to comments provided on Pg2.

Responded by David Yoo/NC on 8/23/18

RESPONSE DISTRIBUTION

Company	Contact	Date Sent
JF Construction Corp	John Ferrante	8/24/2018

Please review and advise Bernards, **WITHIN 7 days**, if there are any additional costs or schedule impacts associated with incorporating the RFI response with the Contract Work. (Include a brief description and rough order estimate of the change with this notification. If no response is received within 7 days, Bernards shall trust that there is no impact to your Contract Price or Schedule.

Question Initiated By: Mitch Michaelis - Bernards
Submitted By: Mitch Michaelis - Bernards



REQUEST FOR INFORMATION

RFI No.: 257

To: Jose Arche

Date: 08-23-18

Company: CSDA Design Group

Discipline: Structural

Project: Marshall Elementary - New 6-8 Classroom Bldg.

Subject: Clarification of Column/Post at GL
20.2/1.2

Response Requested By: 08-30-2018

DRAWINGS & SPECIFICATION REFERENCES		
Drawing Sheet / Specification	Detail / Sub Section	Comments
S-211		
S-212		

QUESTION

No description is provided for the post or column referenced on page 2 of this document.

SUGGESTION

Please clarify

ANSWER

NC Response:

Refer to comments provided on page 2.

By: DY/NC 08/23/18

Response Provided By: _____
 Name Company Date

Question Initiated By: Mitch Michaelis - Bernards
 Submitted By: Mitch Michaelis - Bernards

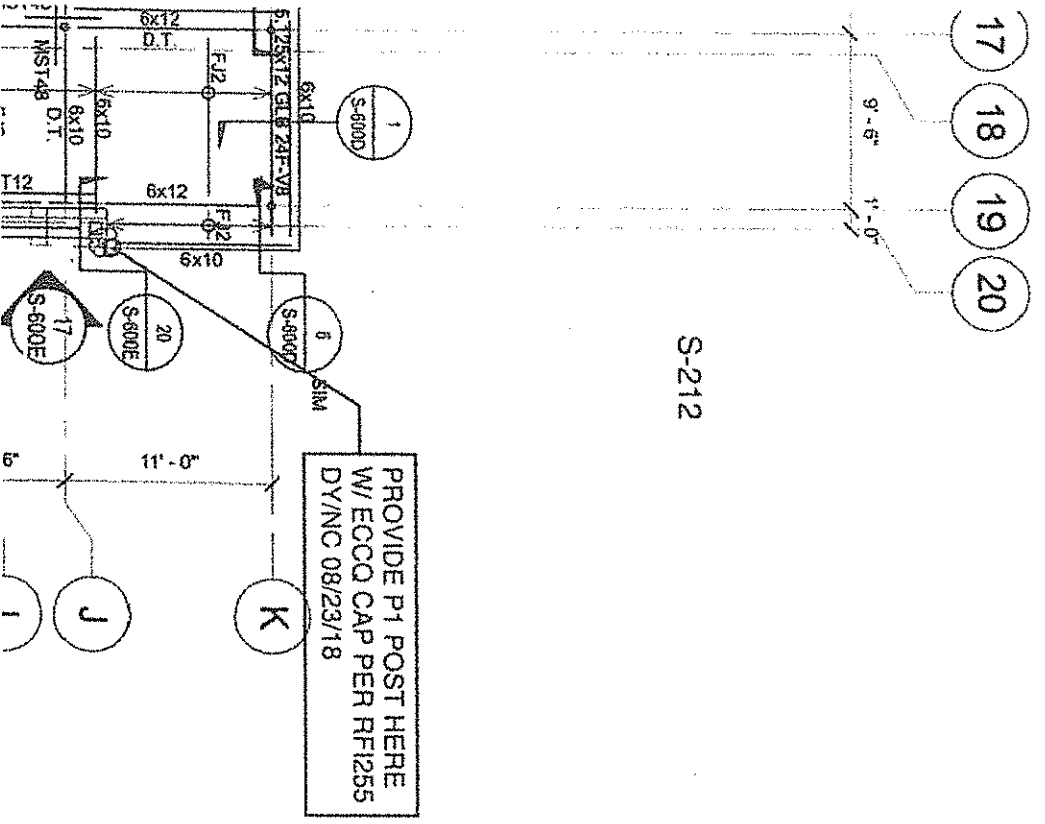
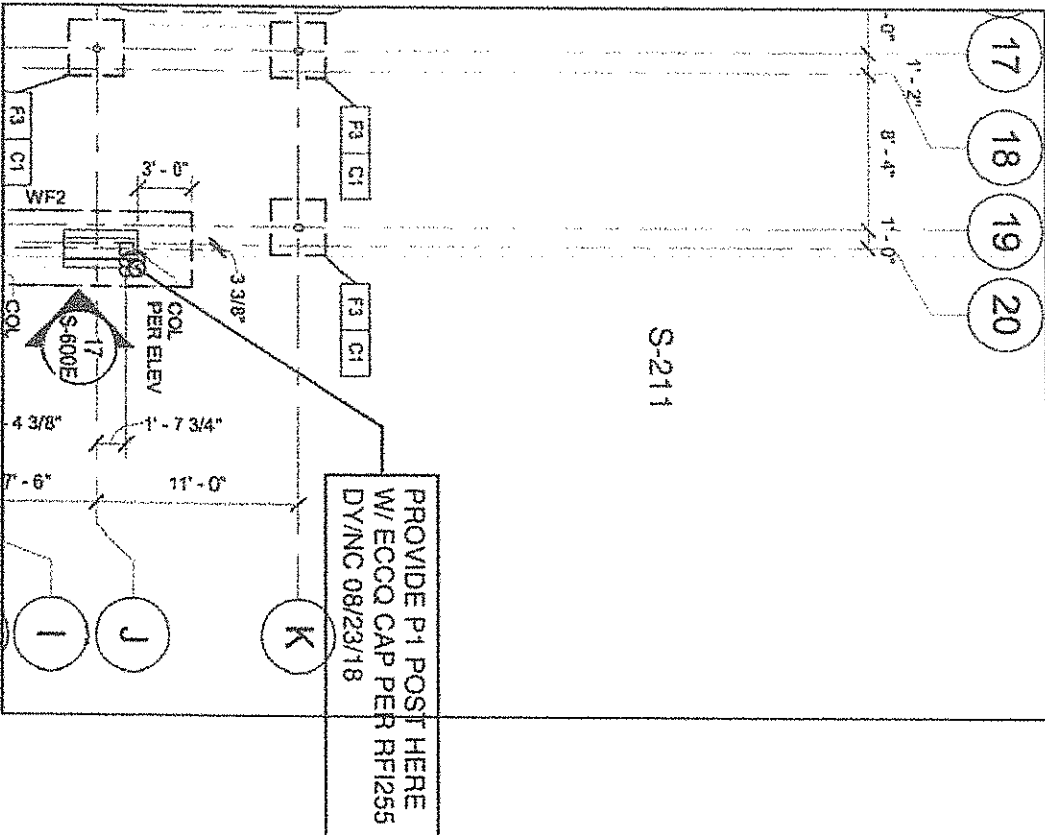



CONTINGENCY ALLOCATION REQUEST

CAR No. 69 R0

Date: 11/8/2018

Project: Marshall Elementary - New 6-8 Classroom Bldg.

DESCRIPTION OF WORK

CCD 19 R&R 6x beams due to new straps at Elevator

SUMMARY OF ALLOCATIONS

Item Description	Company	Amount Requested
Subcontract Costs		
CCD 19 R&R 6x beams due to new straps at Elevator	JF Construction Corp	1,259
additional strap connection at BM cantilever at balcony to west stairs.	Subtotal:	1,259
Total Change Order Request Amount		1,259

ACKNOWLEDGEMENT

Oxnard School District

Bernards Bros. Inc.



 Signature
 Jose Arche, CSDA

 Printed Name & Title
 01-24-19

 Date

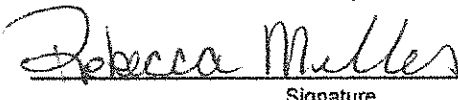

 Signature
 Rebecca Miller Project Manager

 Printed Name & Title
 2/8/17

 Date

JfC CONSTRUCTION CORP LIC #791180

1459 THOUSAND OAKS BLVD H4, THOUSAND OAKS, CA

(805)-496-9255 (805)-497-8334

CHANGE ORDER JFC #44

DESCRIPTION: Provide / installation of beam connections and R and R of 6x beams due to new straps at elevator per CCD 19
Time tracked on T&M dated 10-12-18 and 10-16-18

Date: 10-26-18

Project: MARSHALL CLASSROOM

Subject: Rough Carpentry

Sub-Contractor: **J F Construction Corporation**

DESCRIPTION ADDED WORK	LABOR			MATERIAL				EQUIPMENT				
	HRS	RATE	SUB-TOT	QTY	UNIT	U/P	SUB-TOT	QTY	UNIT	U/P	SUB-TOT	
No Material												
Foreman Labor	1	\$ 81.00	\$ 81.00									
Labor	13	\$ 78.00	\$ 1,014.00									
TOTAL	14		\$ 1,095.00				\$ -					
SALES TAX							\$ -					
							TOTAL	\$ -			\$ -	
SUB TOTAL ADDITION BEFORE MARK-UP												
							SUBTOTAL				\$ 1,095.00	
							SUBCONTRACTORS 15 %					\$ 164.25
							(X) COST () CREDIT					
							TOTAL		\$			1,259.25
GENERAL CONTRACTOR: ACCEPTED BY:												
Signature												

JFC # 44

Time and Material Reports 001

J.F. Construction Corporation		Date: 10-16-18	Day: TUESDAY
Project: MARSHAW E.C.		Weather: Sunny	
Extra work performed today:		Employees	
<u>CCD 19</u>			
	Names	Union	Hours
INSTALL 5/8 x 1 1/2 GLB INTO	MARIO AHUMADA		2
FABRICATED BUCKET @	LUIS DELATORRE		1.5
GL 3 & K	MARIO AHUMADA		2
INSTALL 5/8 GLB x 1 1/2 GLB INTO	MARIO AHUMADA		2
FABRICATED BUCKET @	LUIS DELATORRE		1.5
GL 3-2 & K			
	TOTAL		7
Extra Lumber, Hardware Count and Equipment used:			
5/8 x 9 1/2 MB - 6		Time & Material verified	
<p>Verification of Time Only Subject to the Terms and Conditions of the Subcontract Agreement</p> <p>By: <u>Will Vargo</u> Signature: <u>[Signature]</u> Print Name: <u>Will Vargo</u> Date: <u>10-16-18</u></p>		<p>Merit to be determined by CFW <u>[Signature]</u> 10/16/18</p>	
<p>Note that the work requested to perform per an RFI <u>CCD</u> EOR or IIR deviates from the original plans and are therefore considered additional work to the contract. A representative of Bernard Bros. is required to acknowledge this work prior to JFC commencement of such work per contract documents.</p> <p><u>Will Vargo</u> 10-16-18</p>			
General Contractor		Owner	
<p>JFC has completed said work on this T&M ticket and the material and hours have been reviewed and are accurate.</p> <p><u>Will Vargo</u> 10-16-18</p>			
General Contractor		Owner	

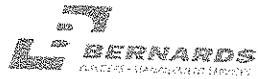

HOURLY LABOR COST RATES

Sub/Contractor: JF Construction Corp Trade: Rough Carpentry
 Date: 2/14/2018 Classification: 6100
 Project: Marshall E.S.
 Rate Effective Through: July 1, 2018 Union: Non Union:

	Straight Time	Time & 1/2	Double Time
A. HOURLY TAXABLE WAGE COSTS			
Hourly Wage	\$ 42.41	\$ 63.62	\$ 84.82
Vacation & Holiday Accrual	\$ 6.19	\$ 6.19	\$ 6.19
Hourly Taxable Wage Costs Subtotal	\$ 48.60	\$ 69.81	\$ 91.01
B. HOURLY PAYROLL TAX & INSURANCE			
Social Security	\$ 3.61	\$ 4.32	\$ 5.64
Medicare	\$ 0.70	\$ 1.01	\$ 1.32
FUI	\$ 0.29	\$ 0.42	\$ 0.55
SUI	\$ 3.01	\$ 4.32	\$ 5.64
Workers Compensation Insurance	\$ 8.97	\$ 8.97	\$ 8.97
General Liability Insurance (If Applicable)	\$ -	\$ -	\$ -
Hourly Payroll Tax & Insurance Subtotal	\$ 15.98	\$ 19.04	\$ 22.12
C. HOURLY BENEFITS			
Health & Welfare (or equivalent)	\$ 7.50	\$ 7.50	\$ 7.50
Pension & Retirement (or equivalent)	\$ 4.91	\$ 4.91	\$ 4.91
Training (or equivalent)	\$ 1.01	\$ 1.01	\$ 1.01
Hourly Benefits Subtotal	\$ 13.42	\$ 13.42	\$ 13.42
TOTAL HOURLY LABOR COST RATE (A+B+C)	\$ 78.00	\$ 102.27	\$ 126.55

Factors NOT allowed in the above hourly labor cost rates:

- | | |
|--------------------------------------|--------------------------------|
| 1. Overhead | 5. Consumables |
| 2. Profit | 6. Bonus or incentive payments |
| 3. Vehicle & transportation expenses | 7. Communications |
| 4. Small tools | 8. Supervision |

APPLICATION FOR APPROVAL OF CONSTRUCTION CHANGE DOCUMENT - CCD CATEGORY A/B

This application is for construction changes, as defined in IR A-6, to approved contract documents. This form shall be completed by the Design Professional in General Responsible Charge of the project, in accordance with California Code of Regulations, Title 24, Part 1, Section 4-338 (c) and in compliance with DSA IR A-6.

School District/Owner: Oxnard School District	DSA File #: 56 - 22
Project Name/School: Marshall Elementary School New Classroom Building	DSA App. #: 03 - 116806

APPLICANT		
CCD Cat. <input checked="" type="checkbox"/> A / <input type="checkbox"/> B, #019	Date Submitted: 02/26/18	Attached Pages?: <input type="checkbox"/> No <input checked="" type="checkbox"/> Yes (07 pages)
For CCD Cat. B, this is a <input type="checkbox"/> voluntary submittal, <input type="checkbox"/> DSA required submittal (attach DSA notification requiring submission).		
Firm Name: CSDA Design Group	Contact Name: Michael Schoen	
Email: mschoen@csdadesigngroup.com	Phone Number: (310) 301-4772	
Address: 889 N Douglas St, Suite 100		
City: El Segundo	State: CA	Zip: 90245
<input type="checkbox"/> A DSA 301-N, DSA 301-P, or 90-Day Letter has been issued for this project.		
<input checked="" type="checkbox"/> For project currently under construction.		
<input type="checkbox"/> To obtain DSA approval of existing uncertified building(s).		

DESIGN PROFESSIONAL IN GENERAL RESPONSIBLE CHARGE	
Name of Design Professional in General Responsible Charge: Michael Schoen	
Professional License #: C-35165	Discipline: Architect

Design Professional in General Responsible Charge Statement: The attached Construction Change Documents have been examined by me for design intent and appear to meet the appropriate requirements of Title 24, California Code of Regulations and the project specifications. They are acceptable for incorporation into the construction of the project.

Signature: *[Signature]*
DESIGN PROFESSIONAL IN GENERAL RESPONSIBLE CHARGE

CHECK THIS BOX: <input checked="" type="checkbox"/> To confirm that all CCD drawings and, when applicable, first sheet or index of calculations and specifications have been stamped and signed by the Responsible Design Professional listed on DSA 1 for this project.
Brief description of construction change (attach additional sheets if needed): Partial plan to denote location where new detail is to be applied. New details provides clarification on design intent of framing connection. SSK -CCD019-001, SSK -CCD019-02 AND SSK-CCD019-03 new detail as approved by SEOR.
Minor clarification was applied to Detail B/SSK-CCD019-03
List of DSA approved drawings affected by this CCD: S-212,4/S-700A & 6/S-600D

DSA USE ONLY	DSA Stamp
SSSA. Widjaja Date 03/17/2018 <input checked="" type="radio"/> Approved / <input type="radio"/> Disapproved / <input type="radio"/> Not Req'd FLS <input checked="" type="checkbox"/> Date _____ <input type="checkbox"/> Approved / <input type="checkbox"/> Disapproved / <input type="checkbox"/> Not Req'd ACS <input checked="" type="checkbox"/> Date _____ <input type="checkbox"/> Approved / <input type="checkbox"/> Disapproved / <input type="checkbox"/> Not Req'd Remarks: <u>DSA APPROVAL FOR 'CLOUDED' PORTION ONLY.</u>	For business office use only Date Sent _____ Return By _____ Delivery Method _____ <div style="border: 1px solid black; padding: 5px; text-align: center;"> APPROVED AWidjaja DIV. OF THE STATE ARCHITECT LOS ANGELES REGIONAL OFFICE DATE <u>03/17/2018</u> Appl. No: <u>03-116806 140 19 SSS.pdf</u> </div>

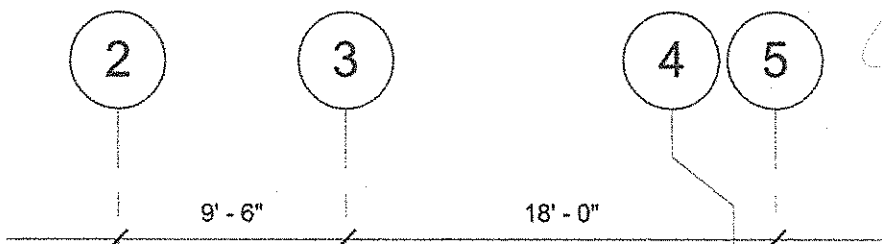
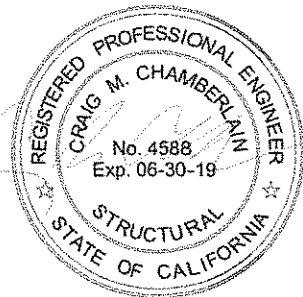

DSA APPROVED AWidjaja
 DIV. OF THE STATE ARCHITECT
 LOS ANGELES REGIONAL OFFICE
 DATE 03/17/2018
 Appl. No: 03-116806_140_19_SSS.pdf

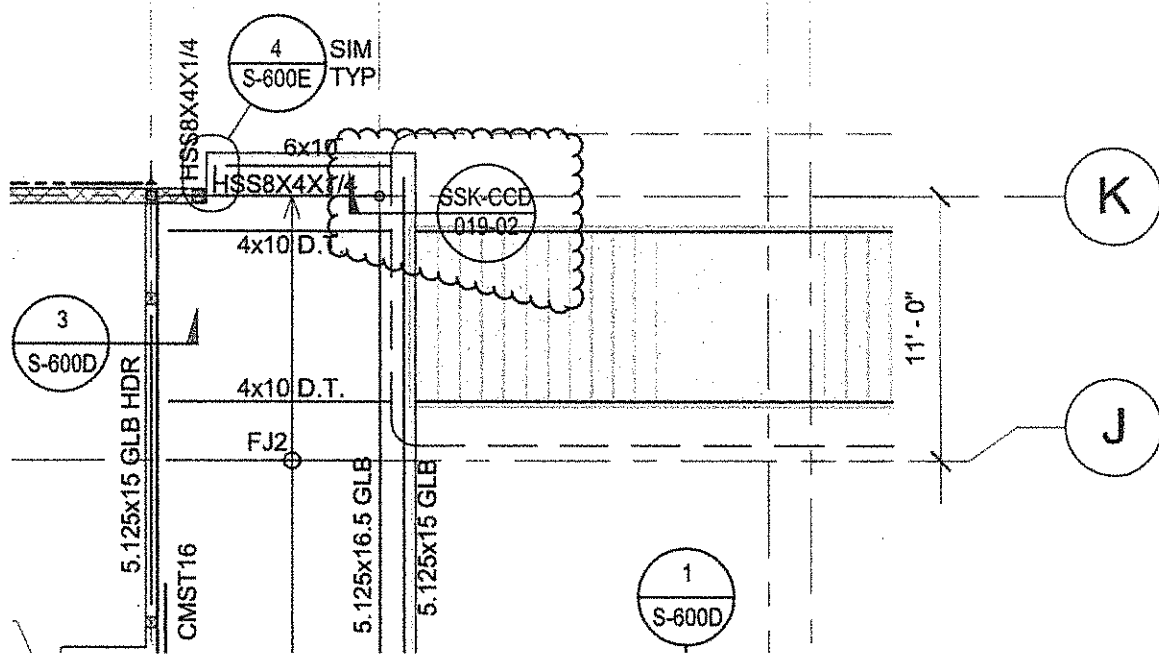

PARTIAL PLAN

1 2ND FLOOR FRAMING PLAN
SCALE: 1/8" = 1'-0"

Description of change:
 Partial plan to denote location where new detail is to be applied. New detail provides clarification on design intent of framing connection.
 referenced drawings/details: 1/S-212

NISHKIAN CHAMBERLAIN
 CONSULTING AND STRUCTURAL ENGINEERS SINCE 1919
 NC PROJECT #: 40340

CSDA PROJECT #:	1534.01	SHEET:	01 OF 03
MARSHALL ES - NEW CLASSROOM BUILDING		DRAWING REFERENCE:	1/S-212
2900 Thurgood Marshall Dr, Oxnard, CA 93036		SCALE:	1/8"=1'-0"
		DATE:	03/06/2018

CSDA DESIGN GROUP

DSA A# 03-116806	Title of sheet Partial Plan of 2nd Floor Walkway	CCD #019	SSK-CCD019-01
-------------------------	---	-----------------	----------------------

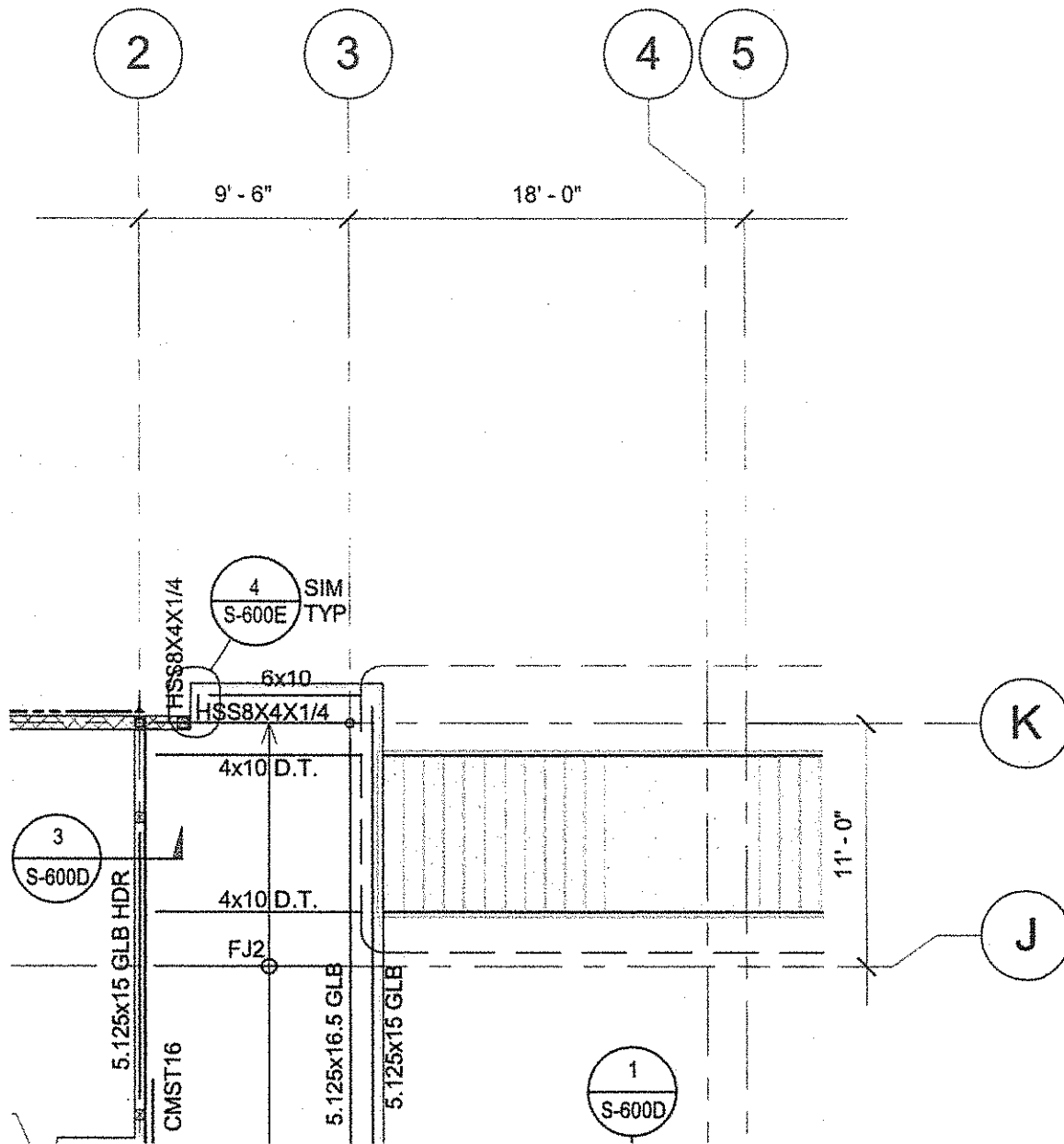

1 2ND FLOOR FRAMING PLAN
SCALE: 1/8" = 1'-0"

PARTIAL PLAN SHEET S-212
FROM DSA APPROVED PLANS
(FOR REFERENCE ONLY)

HSS 8x4x1/4 STEEL BEAM
 PER PLAN W/ 3x TOP NAILED.
 (INTERRUPT NAILED AS REQ'D)
 HSS 5000x0.250 END
 COLUMNS ABOVE & BELOW
 COLUMNS
 TO BASE
 PLATES

FLOOR B.N.
 INTO GLB
 PER PLAN

ANGLE CONN.
 PER 6
 6000D

DSA APPROVED
 DIV. OF THE STATE ARCHITECT
 LOS ANGELES REGIONAL OFFICE
 DATE 03/17/2018
 Appl. No: 03-116806 140_19_SSS.pdf

BEAM TO
 PLATE (TOP
 & BOTTOM)

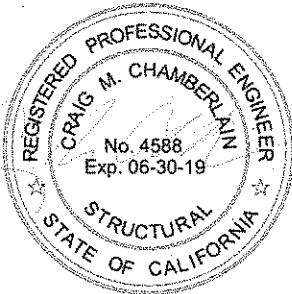

SIM.
 FOR NAILED
 ONLY

5/8" x 10 1/2" GLB
 PER PLAN
 5/8" x 15" GLB
 PER PLAN IN
 1/4" THICK CUSTOM
 SADDLE

A ELEVATION

HSS 8x4x1/4 STEEL
 BEAM PER PLAN
 1/4" THICK CUSTOM
 SADDLE

1x4x1/4 ANGLES PER
 DETAIL 6
 6000D

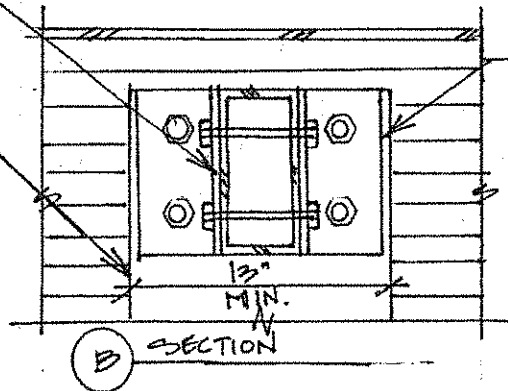

B SECTION

NEW DETAIL

Description of change
 New detail provides clarification on design intent of connection between HSS beam and GLB beams.
 referenced drawings/details: 1/S-212, 4/S-700A, 6/S-600D, SSK-CCD019-03

**NISHKIAN
 CHAMBERLAIN**
 CONSULTING AND STRUCTURAL
 ENGINEERS SINCE 1919
 NC PROJECT #: 40340

CSDA PROJECT #: 1534.01
 MARSHALL ES - NEW CLASSROOM
 BUILDING
 2900 Thurgood Marshall Dr, Oxnard, CA 93036

SHEET: 02 OF 03
 DRAWING REFERENCE: SSK-CCD019-01
 SCALE: N.T.S.
 DATE: 03/06/2018

CSDA DESIGN
 GROUP

DSA A# 03-116806 Title of sheet Framing Section at 2nd Floor Walkway **CCD #019** **SSK-CCD019-02**

HSS 8.000x0.250 RND
STEEL COLUMNS ABOVE
& BELOW PER PLAN.

6x10
FLOOR BEAM
PER PLAN

(2) L₄x₄x_{3/8}x₇" ANGLES
w/ (2) 3/4" ϕ THROUGH BOLTS
& CUSTOM SADDLE BOLTED
TO ANGLES.

HSS 8x4x1/4
STEEL BEAM PER PLAN

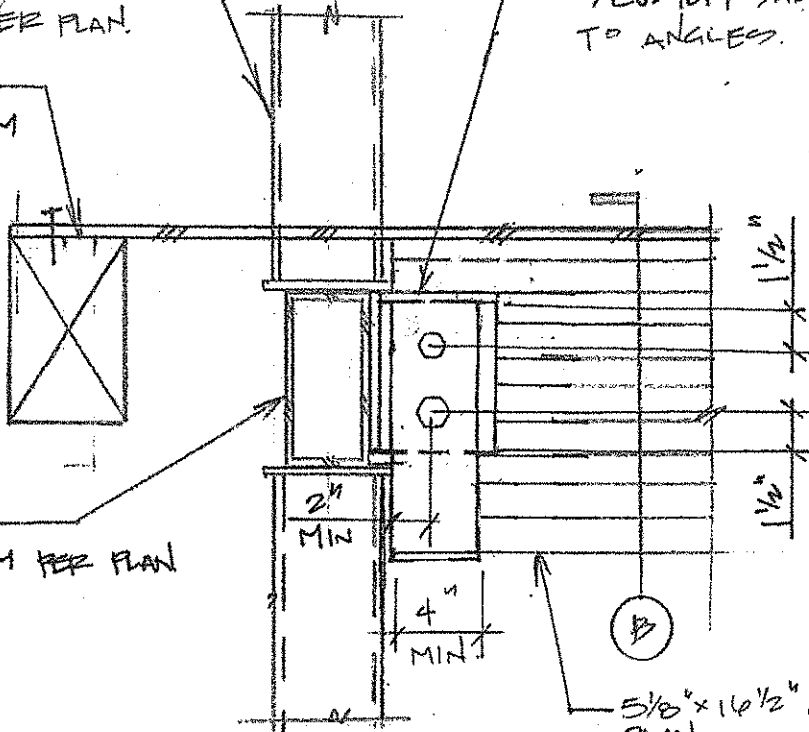

5/8" x 16 1/2" GLB PER
PLAN

1/4" THICK CUSTOM SADDLE
BOLTED TO ANGLES

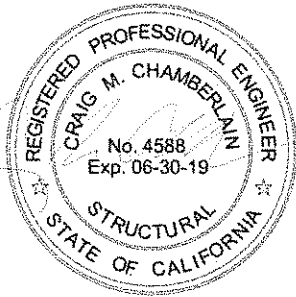

A ELEVATION

DSA APPROVED
DIV. OF THE STATE ARCHITECT
LOS ANGELES REGIONAL OFFICE
DATE 03/17/2018
Appl. No: 03-116806_140_19_SSS.pdf

HSS 8x4x1/4
STEEL BEAM PER PLAN

5/8" x 16 1/2" GLB
PER PLAN. DIM

EA. ANGLE
LEG.

B SECTION

EA. SIDE
OF BEAM

NEW DETAIL

Description of change:

New detail provides clarification on design intent of connection GLB to HSS at location of stacking HSS columns.

referenced drawings/details: 1/S-212, SSK-CCD019-01

**NISHKIAN
CHAMBERLAIN**
CONSULTING AND STRUCTURAL
ENGINEERS SINCE 1919
NC PROJECT #: 40340

CSDA PROJECT #: 1534.01
MARSHALL ES - NEW CLASSROOM
BUILDING
2900 Thurgood Marshall Dr, Oxnard, CA 93036

SHEET: 03 OF 03
DRAWING REFERENCE: 1/S-212
SCALE: N.T.S.
DATE: 03/06/2018

CSDA DESIGN GROUP

DSA A# 03-116806

Title of sheet
Connection at 2nd Floor Walkway

CCD #019

SSK-CCD019-03

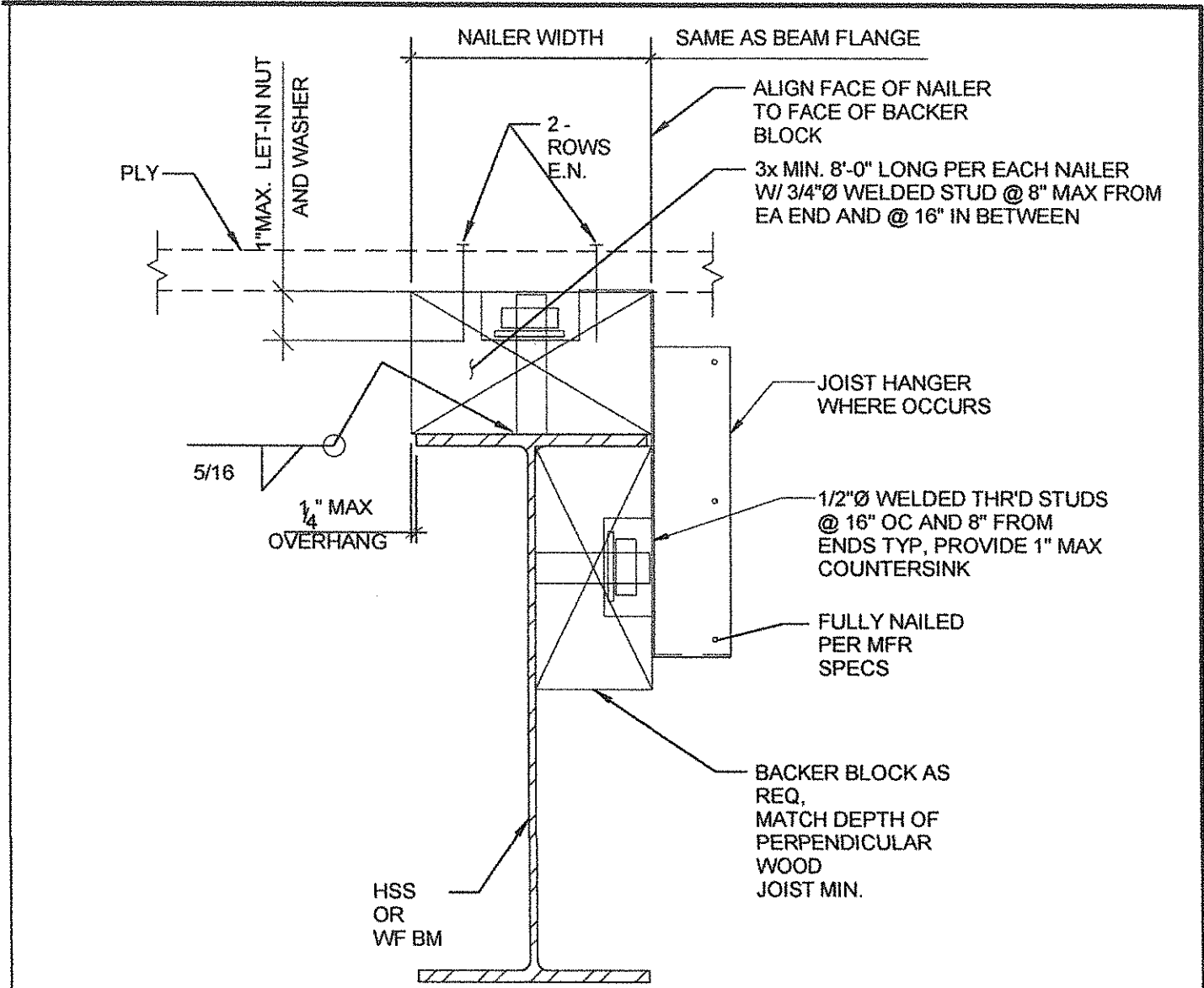

4

TYPICAL NAILER AT STEEL BEAM
 NTS

DETAIL 4/S-700A
 FROM DSA APPROVED PLANS
 (FOR REFERENCE ONLY)

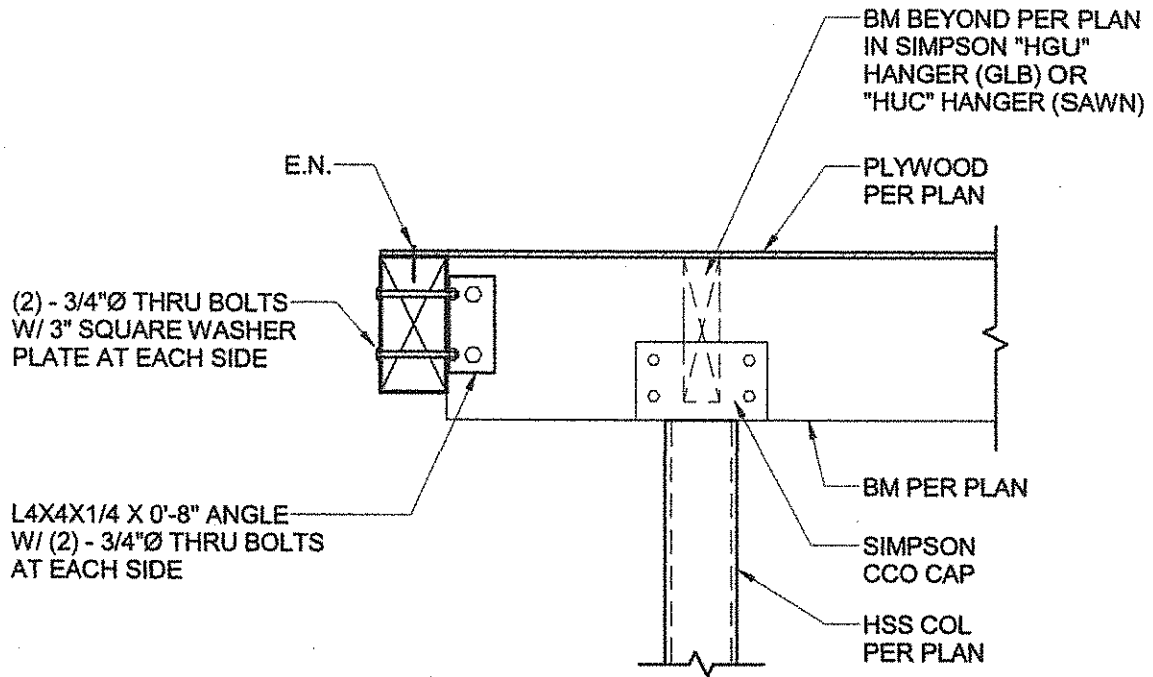

6

CONT BM TO CANTILEVER CONNECTION

3/4" = 1'-0"

DETAIL 6/S-600D
 FROM DSA APPROVED PLANS
 (FOR REFERENCE ONLY)

#17-117

CONSTRUCTION SERVICES AGREEMENT

This Construction Services Agreement (hereinafter referred to as the "Agreement") is entered into this 24th day of August 2017, by and between the Oxnard School District, a California school district organized and existing under the laws of the State of California (hereinafter referred to as the "District") and Bernards which is a contractor licensed by the State of California, with its principal place of business at 555 First Street, San Fernando, CA 91340 (hereinafter referred to as "Contractor").

WHEREAS, the District operates Marshall Elementary School, located at 2900 Thurgood Marshall Drive, Oxnard, California 93036 (hereinafter referred to as the "School Facility"); and

WHEREAS, the District desires to construct and modernize facilities and improvements (as more fully described below) at those portions of the School Facility identified in the Site Lease, as defined in Section 1G below (the "Site"); and

WHEREAS, the District has determined that it is in its best interests to pursue the improvements to the School Facility through the lease-leaseback method of project delivery pursuant to California Education Code §17406 which permits the governing board of the District, without advertising for bids, to lease to Contractor property owned by the District if the instrument by which property is leased requires the lessee to construct, or provide for the construction, on the leased property, of a facility for the use of the District during the term of the lease, and provides that title to that facility shall vest in the District at the expiration of the lease; and

WHEREAS, the District desires to finance a portion of the improvements utilizing the lease/leaseback methodology; and

WHEREAS, the District has conducted an RFQ process by which it selected Contractor; and

WHEREAS, the District intends to undertake work to improve the School Facility, the scope of which is generally described in **Exhibit A** attached hereto and incorporated by reference herein; and

WHEREAS, in connection with the approval of this Agreement, the District will enter into a site lease with Contractor, under which it will lease to Contractor the Site in order for Contractor to construct the Project as described in the Scope of Work set forth generally in **Exhibit A** (hereinafter referred to as the "Scope of Work"); and

WHEREAS, assuming that the District and Contractor can agree on the terms, including the price, for the additional scope of work, the District and Contractor anticipate that the scope of the Project may be amended to include additional work; and

- 1 -

OXNARD SCHOOL DISTRICT

CONSTRUCTION SERVICES AGREEMENT

Marshall New Classroom Building Project

August 24th, 2017

#17-117

WHEREAS, Contractor will lease the Site back to the District pursuant to a sublease agreement, under which the District will be required to make payments to Contractor for the use and occupancy of the Site, including the Project (hereinafter the "Financing"); and

WHEREAS, Contractor represents that it is sufficiently experienced in the construction of the type of facility and type of work sought by the District and is willing to perform said work for lease and the Financing to the District, all as more fully set forth herein; and

WHEREAS, at the expiration of the Site Lease, title to the Site and the improvements thereon will vest with the District;

NOW, THEREFORE, in consideration of the covenants hereinafter contained, the District and Contractor agree as follows:

SECTION 1. DEFINITIONS

- A. **Construction.** The term "Construction" as used in this Agreement includes all labor and services necessary for the construction of the Project, and all materials, equipment, tools, supplies and incidentals incorporated or to be incorporated in such construction as fully described in the Scope of Work set forth in **Exhibit A** attached hereto. Unless otherwise expressly stipulated, Contractor shall perform all work and provide and pay for all materials, labor tools and equipment, including, but not limited to, light, water, and power, necessary for the proper execution and completion of the Project shown on the drawings and described in the specifications developed pursuant to this Agreement.
- B. **Construction Documents.** The term "Construction Documents" means the final drawings, profiles, cross sections, design development drawings, construction drawings, and supplemental drawings based on the plans and specifications developed for the Project pursuant to the Scope of Work set forth in **Exhibit A** attached hereto, including any reference specifications or reproductions prepared by the architect hired by the District (the "Architect") and specifications approved by the District, the Division of the State Architect ("DSA"), and the local agencies having jurisdiction or other regulatory agencies whose approval may be required, which show or describe the location, character, dimensions or details for the Project and specifications for construction thereof.
- C. **Contract Documents.** The term "Contract Documents" as used in this Agreement refers to those documents which form the entire agreement by and between the District and Contractor. The Contract Documents consist of this Agreement, including the exhibits and attachments hereto, the Site Lease, including the exhibits and

#17-117

attachments thereto, the Sublease, including the exhibits and attachments thereto, the Project Manual including the General Conditions thereto, as amended, which is incorporated herein (the "General Conditions"), and the Construction Documents. The term "Contract Documents" shall include all modifications and addenda thereto.

- D. **Guaranteed Maximum Price.** The term "Guaranteed Maximum Price" or "GMP" as used in this Agreement means the Guaranteed Maximum Price established pursuant to Section 5 of this Agreement to be used to calculate the Tenant Improvement Payments and the Sublease Payments to be paid by the District to Contractor pursuant to the Sublease, subject only to any adjustments for Extra Work/Modifications as provided in Section 10 of this Agreement.
- E. **Not Used for this Agreement**
- F. **Project.** The term "Project" shall mean the improvements and facilities to be constructed and installed by Contractor at the School Facility which will result in complete and fully operational facilities as more fully set forth on **Exhibit A** attached hereto.
- G. **Project Manual.** The term "Project Manual" shall mean the compilation of the Specification sections including Division 0, Procurement and Contracting Requirements, Division 1 General Requirements, and technical specifications Division 2 through 33 prepared by the Architect and approved by the District, the DSA, or other regulatory agencies which show or describe the location, character, dimensions or details for the Project, which shall be delivered to Contractor upon execution of this Agreement.
- H. **Site.** The term "Site" as used in this Agreement shall mean those certain parcels of real property and improvements thereon (if any) more particularly described in **Exhibit A** to the Site Lease.
- I. **Site Lease.** The term "Site Lease" as used in this Agreement shall mean the certain Site Lease dated of even date herein between the District and Contractor, together with any duly authorized and executed amendment(s) thereto, pursuant to which the District leases the Site to Contractor.
- J. **Specifications.** The term "Specifications" shall mean those numbered specifications set forth in the Project Manual which shall accompany this Agreement and which are incorporated by reference herein. Individual Specifications may be referred to by their specification number as set forth in the Project Manual.

#17-117

- K. **Subcontractor.** As used in this Agreement, the term "Subcontractor" means any person or entity, including trade contractors, who have a contract with Contractor to perform any of the Construction.
- L. **Sublease.** The term "Sublease" as used in this Agreement shall mean the certain Sublease dated of even date herein between the District and Contractor, together with any duly authorized and executed amendment(s) thereto, pursuant to which the District subleases the Site from Contractor.
- M. **Sublease Payments.** The term "Sublease Payments" as used in this Agreement shall mean the payments made by the District to Contractor pursuant to Section 6 of the Sublease.
- N. **Tenant Improvement Payments.** The term "Tenant Improvement Payments" as used in this Agreement shall mean the payments made by the District to Contractor pursuant to Section 6 of the Sublease.

SECTION 2. CONTRACTOR'S DUTIES AND STATUS

Contractor covenants with the District to furnish reasonable skill and judgment in constructing the Project. Contractor agrees to furnish efficient business administration and superintendence and to furnish at all times an adequate supply of professionals, workers, and materials and to perform the work appropriately, expeditiously, economically, and consistent with the Contract Documents.

SECTION 3. ADDITIONAL SERVICES

If the District requests Contractor to perform additional services not described in this Agreement, Contractor shall provide a cost estimate and a written description of the additional work necessary to complete such additional services. The cost for such additional services shall be negotiated and agreed upon in writing in advance of Contractor performing or contracting for such additional services, and such cost shall be used to adjust the GMP established pursuant to Section 5 hereof. In the absence of a written agreement, the District will not compensate Contractor for additional services, will not adjust the GMP for such additional services, and Contractor will not be required to perform them. It is understood and agreed that if Contractor performs any services that it claims are additional services without receiving prior written approval from the District Board of Education, Contractor shall not be paid for such claimed additional services and the GMP will not be adjusted. Nothing in this Agreement shall be construed as limiting the valuation of such additional services and amount that the GMP will be adjusted for such additional services, should a written agreement for such services be executed by the parties. Notwithstanding the foregoing, Contractor shall not be entitled to compensation, nor will the GMP be adjusted, for additional services required as a result of Contractor's acts, errors or omissions.

SECTION 4. OWNERSHIP OF PLANS AND DOCUMENTS

All original field notes, written reports, drawings, specifications, Construction Documents, and other documents, produced or developed for the Project are the property of the District, regardless of whether the Project is constructed, and shall be furnished to the District. Such documents are not to be used by Contractor or by the Subcontractors on other work nor shall Contractor nor the Subcontractors claim any right to such documents. This shall not deprive Contractor from retaining electronic data or other reproducible copies of the Construction Documents or the right to reuse information contained in them in the normal course of Contractor's professional activities.

SECTION 5. ESTABLISHMENT OF GUARANTEED MAXIMUM PRICE

The "GMP" for the Project shall be **Eight Million Nine Hundred Ninety-Four Thousand Two Hundred Thirty-Six and No/Hundredths Dollars (\$8,994,236.00)**. The GMP consists of (1) no Preconstruction Fee, a Sublease Tenant Improvement Payment in the amount of **Eight Million One Hundred Ninety-Eight Thousand Five Hundred Ninety-Two Dollars and No Cents (\$8,198,592.00)** and, (2) a Contractor Contingency in the amount of **Three Hundred Forty-Five Thousand Nine Hundred Thirty-Two Dollars and No Cents (\$345,932.00)**, and, (3) Sublease Payments in the amount of **\$74,952.00** per month for **6** months, for a total lease value of **Four Hundred Forty-Nine Thousand Seven Hundred Twelve Dollars and No Cents (\$449,712.00)** pursuant to terms and payment schedule as set forth in the Sublease. THE "GMP" WILL NOT BE ESTABLISHED UNTIL DSA HAS APPROVED THE FINAL PLANS AND SPECIFICATIONS AND THE BOARD APPROVES IT PRIOR TO NTP FOR CONSTRUCTION. The GMP will then be brought to the Board of Trustees as a revision to this section of this agreement. Until such time this section will remain incomplete, the Site Lease and Sublease will not begin and the Contractor will proceed with subcontractor bidding to establish the final GMP for Board acceptance.

The GMP is based upon the DSA approved plans and specifications to exist after this Agreement is entered into between Contractor and the District, and more fully described and referenced in the Scope of Work to be set forth in **Exhibits A and B** attached hereto. Prior to DSA approval Contractor did not perform Preconstruction Services to assist in designing the project. Upon DSA approval of plans and specifications, and the establishment of the GMP the Contractor shall assume the risk of cost overruns which were foreseeable at the time this Agreement is entered into and the GMP determined, except for undocumented events of the type set forth in Section 19 hereof, work mandated by an outside agency after issuance of Construction Documents that could not have been reasonably foreseen from review of the Contract Documents, or costs arising from undocumented geotechnical issues. Contractor acknowledges that (i) Contractor has conducted a site inspection and is familiar with the site conditions based on records, studies and visible conditions relating to construction and labor and (ii) Contractor has reviewed the Contract Documents and is familiar with the contents thereof. District directed changes to the scope of the Project not contemplated in the Scope of Work shall

#17-117

be deemed Extra Work/Modifications pursuant to the procedures set forth in Section 10 of this Agreement. The GMP shall include, but not be limited to, increases in labor and materials. The GMP has been used to calculate the Tenant Improvement Payments and the Sublease Payments to be paid by the District to Contractor pursuant to the Sublease. The GMP includes the cost of all labor, materials, equipment, general conditions, overhead, profit and a Contractor Contingency as indicated above.

The Contractor Contingency is for the purpose of covering the cost of very specific issues that may arise during construction and it may be used only upon the written agreement of the Contractor, the architect of record, and the District. The Contractor Contingency is to be used only to pay Contractor for the following enumerated reasons: (1) additional costs resulting from discrepancies in the bid buy-out process; (2) conflicts, discrepancies or errors in the Construction Documents; (3) work required by the Inspector of Record or any governmental agency involved in the permitting or approval/certification process that is not otherwise shown in the Construction Documents; and (4) any other items of cost agreed to in writing by the Contractor and District to be included in the Contractor Contingency. The Contractor Contingency shall not be used for costs incurred as a result of Contractor's acts, errors or omissions.

Contractor shall be responsible for tracking expenditures of the Contractor Contingency and shall provide periodic written updates to the District as directed. Unused Contractor Contingency and Allowances at Project completion will reduce the GMP and will result in an adjustment of the Tenant Improvement Payments and possibly the Sublease Payments.

The District shall at all times have the right to reduce the scope of the Project. If the District reduces the scope of the Project, the GMP shall be reduced commensurate with the reduced Scope of Work pursuant to the provisions of Section 10, below, and will result in an adjustment of the Tenant Improvement Payments and, if applicable, the Sublease Payments.

SECTION 6. NOTICE TO PROCEED WITH CONSTRUCTION

Upon receipt of an approved GMP, the District shall issue a notice to Contractor to proceed with the Construction of the Project. In the event that a Notice to Proceed with Construction is not issued for the Project, the Site Lease and the Sublease shall terminate upon written notice from the District to Contractor that a Notice of Proceed will not be issued.

SECTION 7. SAVINGS

If Contractor realizes a savings on one aspect of the Project, such savings shall be tracked and Contractor shall provide periodic written updates of such savings. Such savings shall be added to the Contractor Contingency and the use of such savings shall be as set forth in Section 5. However, if such savings are not so utilized, the amount of such savings shall reduce the GMP and will result in an adjustment of the Tenant Improvement Payments and, if applicable, the Sublease Payments.

SECTION 8. SELECTION OF SUBCONTRACTORS

In the interest of minimizing the expenditure of funds for the construction of the Project, Contractor agrees to select Subcontractors who are appropriately licensed by the State of California for each trade component of the Project in a manner that fosters competition. Contractor agrees that it will either solicit bids from potential subcontractors pursuant to the competitive bid procedures set forth in the California Public Contract Code, including specifically Public Contract Code section 20110, et seq., or that it will utilize an informal bidding process established by Contractor which also incorporates competitive bid procedures. Regardless of the method Contractor employs, Contractor will make a good faith effort to contact and utilize DVBE contractors and suppliers in securing bids for performance of the Project in accordance with the procedures set forth in Section 1.77 of the General Conditions. In the event that Contractor chooses to select Subcontractors pursuant to an informal bidding process, Contractor shall ensure that it receives at least three competitive quotes from potential subcontractors for each trade component of the Project, unless the parties agree otherwise on a trade-by-trade basis. The District reserves the right to oversee the bidding process. Contractor shall inform all bidders that the District will not be a party to any contracts for construction services executed by Contractor and selected bidders. Contractor shall submit a listing of proposed subcontractors to the District for the District's review. In no case, will Contractor award any sub-contracts until the District has concurred in the scope and price of the sub-contracted services. In addition, Contractor shall provide the District with full documentation regarding the bids or competitive quotes received by Contractor. In no event, shall such documentation be redacted or obliterated. In the event Contractor does not comply with this provision, the District may terminate this Agreement in accordance with the provisions of the General Conditions. Subcontractors awarded contracts by Contractor shall be afforded all the rights and protections of listed subcontractors under the provisions of the Subletting and Subcontracting Fair Practices Act (Public Contract Code Section 4100, et seq.).

SECTION 9. CONSTRUCTION SCOPE OF WORK

- A. Prior to commencing Construction, Contractor shall comply with the initial schedule requirements set forth in the General Conditions.
- B. Contractor shall complete the Construction pursuant to the Construction Documents as amended subject to any additional DSA or other regulatory approvals as may be required, performing all work set forth in the Scope of Work, and shall make reasonable efforts in scheduling to prevent disruption to classes.
- C. Contractor shall be responsible for complying with all applicable building codes, including without limitation mechanical codes, electrical codes, plumbing codes and fire codes, each of the latest edition, required by the regulatory agencies and for arranging and overseeing all necessary inspections and tests including inspections by

#17-117

the DSA or regulatory agencies, permits and occupancy permits, and ensuring compliance with any Federal and State laws, including, but not limited to, safety procedures and requirements, and construction employee training programs which cover among other items, hazardous chemicals and materials.

- D. Contractor shall establish procedures for the protection of all existing structures, equipment, utilities, and other existing improvements, both on-site and off-site. Contractor assumes all risk of loss of vandalism, theft of property or other property damage ("Vandalism") which occurs at a site at which Contractor is undertaking construction of the Project. Contractor assumes all risk of loss which occurs where Contractor is undertaking construction of the Project from causes due to negligence or misconduct by Contractor, its officers, employees, subcontractors, licensees and invitees. Contractor shall replace District property damaged by such Vandalism or theft or compensate the District for such loss, including payment of out of pocket expenses such as insurance deductibles the District might incur under such circumstances.
- E. Contractor shall develop a mutually agreed upon program with the District to abate and minimize noise, dust, and disruption to normal activities at the existing facilities at the School Facility, including procedures to control on-site noise, dust, and pollution during construction.
- F. The District shall cause the appropriate professionals to stamp and sign, as required, the original Construction Documents or parts thereof and coordinate the Project's design with all utilities.
- G. Contractor shall, for the benefit of the Subcontractors, attend pre-construction orientation conferences in conjunction with the Architect to set forth the various reporting procedures and site rules prior to the commencement of actual construction. Contractor shall also attend construction and progress meetings with District representatives and other interested parties, as requested by the District, to discuss such matters as procedures, progress problems and scheduling. Contractor shall prepare and promptly distribute official minutes of such meetings to all parties in attendance, including without limitation the District, the Architect and the District Inspector of Record.
- H. Contractor shall incorporate approved changes as they occur, and develop cash flow reports and forecasts for submittal to the District as requested. Contractor shall provide regular monitoring of the approved estimates for Construction costs, showing actual costs for activities in progress, and estimates for uncompleted tasks. Contractor shall maintain cost accounting records on authorized additional services or work performed under unit costs, additional work performed on the basis of actual costs of labor and materials, and for other work requiring accounting records.

- 8 -

#17-117

- I. Contractor shall record the progress of the Project and shall submit monthly written progress reports to the District and the Architect including information on the entire Project, showing percentages of completion and the number and amounts of proposed Extra Work/Modifications and their effect on the construction costs as of the date of each respective report.
- J. Contractor shall keep a log containing a record of weather, Subcontractors, work on the site, number of workers, work accomplished, problems encountered, and other similar relevant data as the District may require. Contractor shall make the log available to the District, the Architect, and the District's project manager. The District shall be promptly advised on all anticipated delays in the Project.
- K. The District shall bear the cost for the DSA Inspector, soils testing, DSA or other regulatory agency fees, and special testing required in the construction of the Project. If additional review or permits become necessary for reasons not due to Contractor's fault or because of DSA or regulatory agency requirements or regulations implemented after the date the Final GMP is established and not reasonably anticipated at the time the Final GMP is established, Contractor may seek additional compensation for the cost of that review as an additional cost. In the alternative, the District may pay such costs directly.

SECTION 10. EXTRA WORK/MODIFICATIONS

- A. The District may prescribe or approve additional work or a modification of requirements or of methods of performing the Construction which differ from the work or requirements set forth in the Construction Documents ("Extra Work/Modifications"); and for such purposes the District may at any time during the life of this Agreement, by written order, make such changes as it shall find necessary in the design, line, grade, form, location, dimensions, plan, or material of any part of the work or equipment specified in this Agreement or in the Construction Documents, or in the quantity or character of the work or equipment to be furnished. In the event conditions develop which, in the opinion of Contractor, makes strict compliance with the specifications impractical, Contractor shall notify the District of the need for Extra Work/Modifications by placing the matter on the agenda of regularly scheduled construction meetings with the District for discussion as soon as practicable after the need for the Extra Work/Modifications is determined. Additionally, Contractor shall submit to the District for its consideration and approval or disapproval, a written request for Extra Work/Modifications before such work is performed. If the District approves the request in writing, the costs of the Extra Work/Modification shall be added to or deducted from the GMP or the Scope of Work shall be modified to complete the Project within the

#17-117

GMP, as applicable. Any adjustments to the GMP will result in an adjustment of the Tenant Improvement Payment and, if applicable, the Sublease Payments.

- B. Extra Work/Modifications include work related to unforeseen underground conditions if, and only if, such conditions are not visible or identified on plans, reports or other documents available to Contractor. Extra Work/Modifications do not include underground conditions that are identified on plans, reports or other documents available to Contractor but are in a location different than is set forth on such plans, reports or other documents available to Contractor. It should be noted, however, that the District has advised and provided Contractor with information regarding the shallow water table and recent projects experience with encountering water when digging. Contractor has included in its calculation of the GMP an amount to mitigate for encountering water when completing the scope of work contemplated herein. Therefore, Extra Work/Modifications do not include expenses incurred by, and/or work performed by, Contractor in connection with such shallow water table and with encountering water when digging.
- C. Should Contractor claim that any instruction, request, drawing, specification, action, condition, omission, default or other situation (i) obligates the District to increase the GMP; or (ii) obligates the District to grant an extension of time for the completion of this Agreement; or (iii) constitutes a waiver of any provision in this Agreement, CONTRACTOR SHALL NOTIFY THE DISTRICT, IN WRITING, OF SUCH CLAIM AS SOON AS POSSIBLE, BUT IN NO EVENT WITHIN MORE THAN TEN (10) DAYS FROM THE DATE CONTRACTOR HAS ACTUAL OR CONSTRUCTIVE NOTICE OF THE CLAIM. CONTRACTOR SHALL ALSO PROVIDE THE DISTRICT WITH SUFFICIENT WRITTEN DOCUMENTATION SUPPORTING THE FACTUAL BASIS OF THE CLAIM including items used in valuing said claim. Contractor shall be required to certify under penalty of perjury the validity and accuracy of any claims submitted. Contractor's failure to notify the District within such ten (10) day period shall be deemed a waiver and relinquishment of the claim against the District.
- D. Expenses of reconstruction and/or costs to replace and/or repair damaged materials and supplies, provided that Contractor is not fully compensated for such expenses and/or costs by insurance or otherwise, shall be included in an increase to the GMP if said expenses are the result of the negligent acts or omissions of the District, or its principals, agents, servants, or employees.

SECTION 11. NOT USED

SECTION 12. PERSONNEL ASSIGNMENT

- A. Contractor shall assign **Carl Magness** as Project Manager/Superintendent for the Project. So long as **Carl Magness** remains in the employ of Contractor, such person shall not be changed or substituted from the Project, or cease to be fully committed to the Project except as provided in this Section. In the event Contractor deems it necessary, Contractor shall replace the manager and/or the superintendent for the Project with a replacement with like qualifications and experience, subject to the prior written consent of the District, which consent shall not be unreasonably withheld. Any violation of the terms of paragraph A of this Section 12 shall entitle the District to terminate this Agreement for breach, pursuant to the provisions of the General Conditions.
- B. Notwithstanding the foregoing provisions of paragraph A of Section 12, above, if any manager and/or superintendent proves not to be satisfactory to the District, upon written notice from the District to Contractor, such person(s) shall be promptly replaced by a person who is acceptable to the District in accordance with the following procedures: Within five (5) business days after receipt of a notice from the District requesting replacement of any manager and/or superintendent or discovery by Contractor that any manager and/or superintendent is leaving their employ, as the case may be, Contractor shall provide the District with the name of an acceptable replacement/substitution together with such information as the District may reasonably request about such replacement/substitution. The replacement/substitution shall commence work on the Project no later than five (5) business days following the District's approval of such replacement, which approval shall not be unreasonably withheld. If the District and Contractor cannot agree as to the replacement/substitution, the District shall be entitled to terminate this Agreement for breach pursuant to the provisions of the General Conditions.

SECTION 13. BONDING REQUIREMENTS

Contractor shall fully comply with the requirements set forth in Section 6.9 of the General Conditions.

SECTION 14. PAYMENTS TO CONTRACTOR

- A. Contractor shall finance the cost of construction of the Project which costs shall not exceed the GMP, which shall not be adjusted except as otherwise provided in this Agreement. The District shall pay Contractor Tenant Improvement Payments and Sublease Payments pursuant to the terms and conditions of Section 6 of the Sublease. In the event of a dispute between the District and Contractor, the District may withhold from the Tenant Improvement Payments and the Sublease Payments an amount not to exceed one hundred fifty percent (150%) of the disputed amount.

- B. This Agreement is subject to the provisions of California Public Contract Code Sections 7107, 7201 and 20104.50 as they may from time to time be amended.
- C. For purposes of this Agreement, the acceptance by the District means acceptance made only by an action of the governing body of the District in session. Acceptance by Contractor of the final Tenant Improvement Payment or the Sublease Payment, as the case may be, shall constitute a waiver of all claims against the District related to those amounts.

SECTION 15. CONTRACTOR'S CONTINUING RESPONSIBILITY

Neither the final payment nor any provision in the Contract Documents shall relieve Contractor of responsibility for faulty materials or workmanship incorporated in the Project or for any failure to comply with the requirements of the Contract Documents.

SECTION 16. INSURANCE

Contractor shall provide, during the life of this Agreement, the types and amounts of insurance set forth in Article 6 of the General Conditions, which are incorporated by reference herein.

SECTION 17. USE OF PREMISES

Contractor shall confine operations at the Site to areas permitted by law, ordinances, permits and the Construction Documents and shall not unreasonably encumber the Site or existing School Facilities at the Site with any materials or equipment. Contractor shall not load or permit any part of the work to be loaded with a weight so as to endanger the safety of persons or property at the Site.

SECTION 18. SITE REPRESENTATIONS

The District warrants and represents that the District has, and will continue to retain at all times during the course of construction, legal title to the Site and that said land is properly subdivided and zoned so as to permit the construction and use of said Site with respect to the Project. The District further warrants and represents that title to said land is free of any easements, conditions, limitation, special permits, variances, agreements or restrictions which would prevent, limit or otherwise restrict the construction or use of said Site pursuant to this Agreement. Reference is made to the fact that the District has provided information on the Site to Contractor. Such information shall not relieve Contractor of its responsibility; and the interpretation of such data regarding the Site, as disclosed by any borings or other preliminary investigations, is not warranted or guaranteed, either expressly or implicitly, by the District. Contractor shall be responsible for having ascertained pertinent local conditions such as location,

#17-117

accessibility and general character of the Site and for having satisfied itself as to the conditions under which the work is to be performed. No claim for any allowances because of Contractor's error or negligence in acquainting itself with the conditions at the Site will be recognized.

SECTION 19. HAZARDOUS WASTE AND UNKNOWN PHYSICAL CONDITIONS

Contractor shall comply with the District's Hazardous Materials Procedures and Requirements as set forth herein.

- A. If the District has identified the presence of hazardous materials on or in proximity to the Site (the "Pre-existing Hazardous Materials"), Contractor shall review all information provided by the District that characterizes the Pre-existing Hazardous Materials and shall take the actions approved by DTSC and issued by the District necessary to address the Pre-existing Hazardous Materials in the performance of the work. Contractor shall conduct the work based on this information issued at the time contract documents are executed. Contractor shall immediately communicate, in writing, any variances from available information to the District.
- B. The District will retain an additional independent environmental consultant to perform the investigation, inspection, testing, assessment, sampling and analysis necessary to prepare and recommend a remediation plan for the Pre-existing Hazardous Materials for the District's approval (the "Remediation Plan").
- C. The District will retain title to all Pre-existing Hazardous Materials encountered during the work. This does not include hazardous material generated by Contractor, including but not limited to used motor oils, lubricants, cleaners, etc. Contractor shall dispose of such hazardous waste in accordance with the provisions of the Contract Documents, as well as local, State and Federal laws and regulations. The District will be shown as the hazardous waste generator and will sign all hazardous waste shipment manifests for non-Contractor generated hazardous waste. Nothing contained within these Contract Documents shall be construed or interpreted as requiring Contractor to assume the status of owner or generator of hazardous waste substances for non-Contractor generated hazardous wastes.
- D. Except as otherwise provided herein, it is the responsibility of Contractor to obtain governmental approvals relating to Hazardous Materials Management, including Federal and State surface water and groundwater discharge permits and permits for recycling and reuse of hazardous materials for all work noted in the contract documents. Contractor shall be responsible for coordinating compliance with such governmental approvals and applicable governmental rules with the District's hazardous materials consultant, including those governing the preparation of waste profiles, waste manifests, and bills of lading. If Contractor encounters hazardous materials, it shall immediately notify the District in writing. The District, Consultant and

- 13 -

#17-117

Contractor shall jointly establish the plan for disposition and actions to be taken with respect to the hazardous materials, subject to final written approval by the District.

E. If, during construction, Contractor encounters materials, conditions, waste, contaminated groundwater or substances, not identified in the District's assessment report, that Contractor reasonably suspects are hazardous materials, Contractor shall stop the affected portion of the work, secure the area, promptly notify the District, and take reasonable measures to mitigate the impact of such work stoppage. The District shall retain the services of an environmental consultant to perform investigation, inspection, testing, assessment, sampling and analysis of the suspect materials, conditions, waste, groundwater or substances.

(1) Found Not to be Hazardous Materials. If the environmental consultant determines that the materials, conditions, waste, contaminated groundwater or substances do not constitute hazardous materials, Contractor shall recommence the suspended work.

(2) Found to be Hazardous Materials. If the environmental consultant determines that the materials, conditions, waste, contaminated groundwater or substances constitute hazardous materials and such hazardous materials require remediation and disposal, then the District, Consultant and Contractor shall jointly establish the plan for disposition and actions to be taken with respect to the hazardous materials, subject to final written approval by the District. All such costs shall be the responsibility of the District.

F. Exacerbation of Pre-Existing Hazardous Materials.

If during construction Contractor encounters pre-existing environmental conditions that it knew or should have known involve hazardous materials (the "Point of Discovery") (which encounters may include an unavoidable release or releases of hazardous materials) then Contractor must immediately stop the affected portion of the work. If Contractor fails to immediately stop the affected portion of the work after the Point of Discovery, then Contractor is solely responsible for any resultant Exacerbation Cost. "Exacerbate," in all its forms, means the worsening effects of Contractor's failure to stop the affected portion of work after the Point of Discovery. "Exacerbation Cost" means the differential between (i) the actual increase in the cost of remediation and delays to the Project attributable to pre-existing environmental conditions involving hazardous substances, and (ii) the cost thereof or delays thereto had Contractor immediately stopped the affected portion of the work after the Point of Discovery. The standard of "should have known" applies to Contractor's supervisory personnel, whether or not on the Site. Contractor's supervisory personnel must have had the hazardous material training required by applicable OSHA and Cal OSHA rules or regulations.

- 14 -

SECTION 20. INDEPENDENT CONTRACTOR

- A. Contractor is retained as an independent contractor and is not employed by the District. No employee or agent of Contractor shall become, or be considered to be, an employee of the District for any purpose. It is agreed that the District is interested only in the results obtained from service under this Agreement and that Contractor shall perform as an independent contractor with sole control of the manner and means of performing the services required under this Agreement. Contractor shall complete this Agreement according to its own methods of work which shall be in the exclusive charge and control of Contractor and which shall not be subject to control or supervision by the District except as to results of the work. It is expressly understood and agreed that Contractor and its employees shall in no event be entitled to any benefits to which the District employees are entitled, including, but not limited to, overtime, retirement benefits, insurance, vacation, worker's compensation benefits, sick or injury leave or other benefits.
- B. Contractor shall be responsible for all salaries, payments, and benefits for all of its officers, agents, and employees in performing services pursuant to this Agreement.

SECTION 21. ACCOUNTING RECORDS

Contractor, and all Subcontractors, shall check all materials, equipment and labor entering into the work and shall keep or cause to be kept such full and detailed accounts as may be necessary for proper financial management under this Agreement, including true and complete books, records and accounts of all financial transactions in the course of their activities and operations related to the Project. These documents include sales slips, invoices, payrolls, personnel records, requests for Subcontractor payment, and other data relating to all matters covered by the Contract Documents (the "Data"). The Data shall be maintained for ten (10) years from the latest expiration of the term (as such may be extended) of any of the Contract Documents. Contractor shall use its best efforts to cause its Subcontractors to keep or cause to be kept true and complete books, records and accounts of all financial transactions in the course of its activities and operations related to the Project. Upon completion of the Project, Contractor shall provide the District with one (1) complete copy of the Data.

The District, at its own costs, shall have the right to review and audit, upon reasonable notice, the books and records of Contractor and any Subcontractors concerning any monies associated with the Project.

SECTION 22. PERSONAL LIABILITY

Neither the trustees, officers, employees, or agents of District, the District's representative, or Architect shall be personally responsible for any liability arising under the Contract Documents.

SECTION 23. AGREEMENT MODIFICATIONS

No waiver, alteration or modification of any of the provisions of this Agreement shall be binding upon either the District or Contractor unless the same shall be in writing and signed by both the District and Contractor.

SECTION 24. NOTICES

Any notices or filings required to be given or made under this Agreement shall be served, given or made in writing upon the District or Contractor, as the case may be, by personal delivery or registered mail (with a copy sent via fax or regular mail) to the respective addresses given below or at such other address as such party may provide in accordance with the provisions herein. Any change in the addresses noted herein shall not be binding upon the other party unless preceded by no less than thirty (30) days prior written notice.

If to Contractor:

Bernards
555 First Street
San Fernando, CA 91340
Attn: Rick Fochtman

If to the District:

Oxnard School District
1051 South A Street
Oxnard, California 93030
Attn: Dr. Cesar Morales, Superintendent

With a copy to Nitasha Sawhney,
Garcia, Hernandez, Sawhney & Bermudez LLP
2490 Mariner Square Loop, Suite 140
Alameda, CA 94501

And with an additional copy to Scott Burkett,
Caldwell Flores Winters, Inc.
6425 Christie Ave., Suite 270
Emeryville, CA 94608

Notices under this Agreement shall be deemed to have been given, and shall be effective upon actual receipt by the other parties, or, if mailed, upon the earlier of the fifth (5th) day after mailing or actual receipt by the other party.

SECTION 25. ASSIGNMENT

Neither party to this Agreement shall assign this Agreement or sublet it as a whole without the written consent of the other, nor shall Contractor assign any monies due or to become due to it hereunder without the prior written consent of the District.

SECTION 26. PROVISIONS REQUIRED BY LAW

Each and every provision of law and clause required to be inserted in these Contract Documents shall be deemed to be inserted herein and the Contract Documents shall be read and enforced as though it were included herein, and if through mistake or otherwise any such provision is not inserted or is not inserted correctly, then upon application of either party the Contract Documents shall forthwith be physically amended to make such insertion or correction.

SECTION 27. HEADINGS

The headings in this Agreement are inserted only as a matter of convenience and reference and are not meant to define, limit or describe the scope or intent of the Contract Documents or in any way to affect the terms and provisions set forth herein.

SECTION 28. APPLICABLE LAW

This Agreement shall be governed by and construed in accordance with the laws of the State of California. The parties irrevocably agree that any action, suit or proceeding by or among the District and Contractor shall be brought in whichever of the Superior Courts of the State of California, Ventura County, or the Federal Court for the Central District of California in Los Angeles, California, has subject matter jurisdiction over the dispute and waive any objection that they may now or hereafter have regarding the choice of forum whether on personal jurisdiction, venue, forum non conveniens or on any other ground.

SECTION 29. SUCCESSION OF RIGHTS AND OBLIGATIONS

All rights and obligations under this Agreement shall inure to and be binding upon the successors and assigns of the parties hereto.

SECTION 30. NOTIFICATION OF THIRD PARTY CLAIMS

The District shall provide Contractor with timely notification of the receipt by the District of any third-party claim relating to this Agreement, and the District may charge back to Contractor the cost of any such notification.

SECTION 31. SEVERABILITY

If any one or more of the terms, covenants or conditions of this Agreement shall to any extent be declared invalid, unenforceable, void or voidable for any reason whatsoever by a court of competent jurisdiction, the finding or order or decree of which becomes final, none of the remaining terms, provisions, covenants and conditions of the Contract Documents shall be affected thereby, and each provision of the Contract Documents shall be valid and enforceable to the fullest extent permitted by law.

SECTION 32. ENTIRE AGREEMENT

This Construction Services Agreement and the additional Contract Documents as defined in paragraph C of Section 1 herein, including the Site Lease, the Sublease, and the Specifications, drawings, and plans constitute the entire agreement between Contractor and the District. The Contract Documents shall not be amended, altered, changed, modified or terminated without the written consent of both parties hereto, except as otherwise provided in Section 10 hereof.

SECTION 33. EXECUTION IN COUNTERPARTS

This Agreement may be executed in any number of counterparts, each of which shall be an original, but all of which together shall constitute one instrument.

IN WITNESS, WHEREOF the parties hereto, intending to be legally bound thereby, have executed this Agreement effective as of the date first above written.

CONTRACTOR

Bernards
By: Rick Fochtman

By: Rick Falt

Title: Executive Vice President

Date: 8/29/2017

THE DISTRICT

Oxnard School District,
a California school district
By: Lisa A. Franz, Director, Purchasing

By: Lisa A. Franz

Title: Director, Purchasing

Date: 9-7-17

#17-117

EXHIBIT A

Scope of Work (Plans & Specifications)

Marshall New Classroom Building

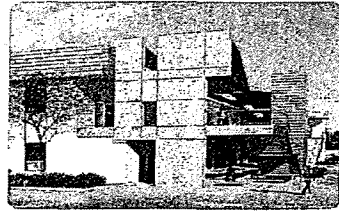
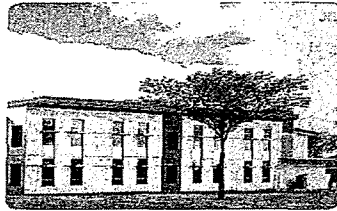
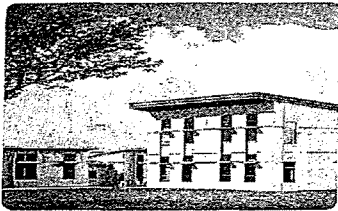

100% Construction Documents Package

Oxnard School District

October 4, 2016

*LFEB. 17. 2017
DCA A# 03 - 114806*

BINDER A

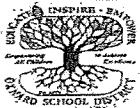

Oxnard School District
Marshall New Classroom Building
2900 Thurgood Marshall Dr. Oxnard, CA 93036

CSDA | DESIGN
GROUP

#17-117

EXHIBIT A, continued

BIDDING DOCUMENTS TABLE OF CONTENTS

VOLUME 1 of 2 (Not submitted to DSA)

DIVISION 00 - PROCUREMENT AND CONTRACTING REQUIREMENTS

00 2150	List of Subcontractors
00 2400	Statement of Bidder's Qualifications
00 2600	Bid Bond
00 4000	Labor and Material Payment Bond
00 4100	Performance Bond
00 4150	Certificate of Worker's Compensation Insurance
00 5100	Background Check and Fingerprinting Procedures for Contractors
00 5300	Guarantee and Standard Forms
00 7000	General Conditions

DIVISION 1 -- 2 (Not Used)

Volume 2 of 2

DIVISION 03 - CONCRETE

03 1000	Concrete Forming Accessories
03 2000	Concrete Reinforcing
03 3000	Cast-In-Place Concrete

DIVISION 04 - MASONRY

04 2200	Concrete Unit Masonry
---------	-----------------------

DIVISION 05 - METALS

05 1200	Structural Steel Framing
05 5000	Metal Fabrications

DIVISION 06 - WOOD, PLASTICS, AND COMPOSITES

06 1000	Rough Carpentry
06 1733	Wood I-Joists
06 1813	Glued Laminated Beams
06 4000	Architectural Woodwork

TABLE OF CONTENTS

MARSHALL NEW CLASSROOM BUILDING

- 20 -

OXNARD SCHOOL DISTRICT

CONSTRUCTION SERVICES AGREEMENT

Marshall New Classroom Building Project

August 24th, 2017

#17-117

EXHIBIT A, continued

DIVISION 07 - THERMAL AND MOISTURE PROTECTION

07 1326 Self Adhering Sheet Wang
07 2100 Thermal Insulation
074000 Metal Roof Panels
075416 Polyvinyl Chloride (PVC) Roofing
076000 Flashing Sheet Metal
078400 Fire Stop and Smoke Seals
079200 Joint Sealants

DIVISION 08 - OPENINGS

08 1113 Hollow Metal Doors and Frames
08 1416 Flush Wood Doors
08 3116 Access Panels and Frames
08 3613 Sectional Doors
08 5113 Aluminum Windows
08 7100 Door Hardware
08 8000 Glazing

DIVISION 09 - FINISHES

09 2200 Cement Plastering
09 2900 Gypsum Board
09 3013 Ceramic Tiling
09 5123 Acoustical Tile Ceilings
09 6513 Rubber Base
09 6519 Resilient Tile Flooring
09 9000 Paints and Coatings

DIVISION 10 - SPECIALTIES

101400 Signage
102113.17 Phenolic-Core Shower and Dressing Compartments
102800 Toilet Accessories
105200 Fire Extinguishers

DIVISION 11 - EQUIPMENT

116800 Playfield Equipment and Structures

TABLE OF CONTENTS

MARSHALL NEW CLASSROOM BUILDING

- 21 -

OXNARD SCHOOL DISTRICT

CONSTRUCTION SERVICES AGREEMENT

Marshall New Classroom Building Project

August 24th, 2017

EXHIBIT A, continued



DIVISION 12 - FURNISHINGS

- 12 2413 Roller Window Shades
- 12 3553 Manufactured Plastic-Laminate-Faced Casework

DIVISION 13 (Not Used)

DIVISION 14 - CONVEYING EQUIPMENT

- 14 2123 Machine-Room-Less Electric Traction Passenger Elevators

DIVISION 15 – 20 (Not Used)

DIVISION 21 - FIRE SUPPRESSION

- 21 1000 Fire Protection

DIVISION 22 – PLUMBING



- 22 0500 Basic Materials and Methods
- 22 0553 Identification
- 22 0700 Insulation
- 22 0800 Equipment and Systems Tests
- 22 1100 Domestic and Industrial Water Systems
- 22 1300 Drainage System
- 22 4000 Plumbing Fixtures

DIVISION 23 – HEATING, VENTILATION, AND AIR CONDITIONING (HVAC)

- 23 0000 General Provisions
- 23 0513 Electric Motors and Controllers
- 23 0548 Vibration Isolation and Seismic Restraints
- 23 2500 Water Treatment
- 23 3100 Air Transmission and Distribution System
- 23 8000 Air Conditioning and Air Handling Equipment
- 23 9000 Building Management System

DIVISION 24 – 25 (Not Used)



DIVISION 26 - ELECTRICAL

- 26 0126 Inspection Test and Acceptance

TABLE OF CONTENTS
MARSHALL NEW CLASSROOM BUILDING

EXHIBIT A, continued

26 0500	Common Work Results for Electrical
26 0513	Basic Electrical Materials and Methods
26 0519	Low-Voltage Wires (600 Volt AC)
26 0526	Grounding and Bonding
26 0533	Raceways and Boxes Fitting and Supports
26 0586	Motors and Drives
26 0800	Electrical Systems Commissioning
26 0923	Lighting Control Systems
26 1000	Service Entrance
26 2200	Low-Voltage Transformers
26 2413	Switchboards1000
26 2416	Panelboards and Signal Terminal Cabinets
26 2419	Motor Control Devices
26 5000	Lighting
26 5200	Emergency Power Systems

DIVISION 27 - COMMUNICATIONS

27 0126	Test and Acceptance Requirements for Structured Cabling
27 1013	Structured Cabling
27 4113	Classroom Sound Enhancement System
27 5116	Public Address and Intercommunication Systems
27 5313	Clock and Program Systems

DIVISION 28 – ELECTRONIC SAFETY AND SECURITY

28 1600	Intrusion Detection System
28 3100	Fire Detection and Alarm System

DIVISION 29 – 30 (Not Used)

DIVISION 31 – EARTHWORK

31 1000	Site Clearing
31 2200	Grading
31 2316	Excavation and Fill Paving
31 2319	Excavation and Fill Structures
31 2323	Excavation and Fill Utilities
31 2326	Base Course

TABLE OF CONTENTS

MARSHALL NEW CLASSROOM BUILDING

#17-117

EXHIBIT A, continued

DIVISION 32 – EXTERIOR IMPROVEMENTS



32 0117	Pavement Repair
32 1216	Asphalt Paving
32 1236	Seal for Bituminous Surfacing
32 1313	Site Concrete Work

DIVISION 33 – SITE IMPROVEMENTS

33 1100	Site Water Distribution Utilities
33 3000	Site Sanitary Sewer Utilities
33 4000	Storm Drainage Utilities



TABLE OF CONTENTS
MARSHALL NEW CLASSROOM BUILDING

- 24 -

OXNARD SCHOOL DISTRICT

CONSTRUCTION SERVICES AGREEMENT

Marshall New Classroom Building Project

August 24th, 2017

EXHIBIT A, continued

100% DISTRICT SUBMITTAL MARSHALL NEW CLASSROOM BUILDING <small>2950 THURGOOD MARSHALL DR. OXNARD, CA 93036</small> OXNARD SCHOOL DISTRICT	VOLUME I
DSA FILE NO. 56-22	DSA APPLICATION NO. 03-116806
PTN NO. 72538-91	

DRAWING INDEX

VOLUME I	VOLUME II	
01- GENERAL G-001 COVER SHEET, INDEX, SCOPE OF WORK, VICINITY MAP G-002 GENERAL NOTES, ABBREVIATIONS, SYMBOL LEGEND G-003 FIRE LIFE SAFETY SITE PLAN G-004 ACCESSIBILITY SITE PLAN G-005 BUILDING CODE ANALYSIS G-006 SIGNAGE & FIRE EXTINGUISHER PLANS 6 03-CIVIL C-001 GENERAL NOTES C-002 LEGEND AND ABBREVIATIONS C-101 DEMOLITION PLAN C-102 DEMOLITION PLAN C-103 DEMOLITION PLAN C-201 SITE CONTROL PLAN C-202 SITE CONTROL PLAN C-203 SITE CONTROL PLAN C-204 STRIPING PLAN C-300 COMPOSITE GRADING PLAN C-301 ENLARGED GRADING PLAN C-302 ENLARGED GRADING PLAN C-303 GRADING SECTIONS C-304 GRADING SECTIONS C-401 SITE UTILITY PLAN C-402 SITE UTILITY PLAN C-403 SITE UTILITY PROFILE C-404 SITE UTILITY PROFILE C-701 MISCELLANEOUS DETAILS C-702 MISCELLANEOUS DETAILS C-703 MISCELLANEOUS DETAILS C-704 MISCELLANEOUS DETAILS 22 04- LANDSCAPE L-1 IRRIGATION PLAN L-2 PLANTING PLAN L-3 IRRIGATION & PLANTING DETAILS L-4 IRRIGATION & PLANTING SPECIFICATIONS 4 05- STRUCTURAL S-101 GENERAL NOTES S-101A GENERAL NOTES & ABBREVIATIONS S-211 FOUNDATION PLAN S-212 2ND FLOOR FRAMING PLAN S-213 ROOF FRAMING PLAN S-214 CANOPY ROOF FRAMING PLAN S-400 TYPICAL CONCRETE DETAILS S-400A TYPICAL CONCRETE DETAILS S-401 FOUNDATION DETAILS S-600 TYPICAL WOOD DETAILS S-600A TYPICAL WOOD DETAILS S-600B TYPICAL WOOD DETAILS S-600C TYPICAL WOOD DETAILS S-600D TYPICAL WOOD DETAILS S-800E WALL ELEVATION AND DETAILS S-800F WALL ELEVATION AND DETAILS S-700 FRAMING DETAILS S-700A ELEVATOR DETAILS S-700B STAIR PLANS & DETAILS 19	06- ARCHITECTURAL A-101 SITE PLAN A-102 ENLARGED SITE PLAN A-103 ENLARGED SITE PLAN A-104 SITE DETAILS A-105 SITE DETAILS A-111 FIRST FLOOR PLAN A-112 SECOND FLOOR PLAN A-121 FIRST FLOOR REFLECTED CEILING PLAN A-122 SECOND FLOOR REFLECTED CEILING PLAN A-131 ROOF PLAN A-210 EXTERIOR ELEVATIONS A-211 EXTERIOR ELEVATIONS A-220 INTERIOR ELEVATIONS A-221 INTERIOR ELEVATIONS A-222 INTERIOR ELEVATIONS A-223 INTERIOR ELEVATIONS A-224 TOILET INTERIOR ELEVATIONS A-310 BUILDING SECTIONS A-311 BUILDING SECTIONS A-320 WALL SECTIONS A-321 WALL SECTIONS A-322 WALL SECTIONS A-410 ENLARGED FLOOR PLANS A-411 ENLARGED FLOOR PLANS A-420 VERTICAL CIRCULATION PLANS & SECTIONS A-421 VERTICAL CIRCULATION PLANS & SECTIONS A-500 ROOF DETAILS A-501 ROOF DETAILS A-510 EXTERIOR ENVELOPE DETAILS A-520 WINDOW/DOOR DETAILS A-521 DOOR DETAILS A-530 INTERIOR DETAILS A-531 INTERIOR DETAILS A-535 TOILET DETAILS A-540 CEILING DETAILS A-550 SIGNAGE DETAILS A-560 STAIR DETAILS A-561 ELEVATOR DETAILS A-570 CASEWORK DETAILS A-610 DOOR SCHEDULE A-612 FINISH SCHEDULE A-620 WALL TYPES 27	E-041 PANEL SCHEDULES E-050 ELECTRICAL DETAILS E-090 SIGNAL SYSTEM RISER DIAGRAMS E-101 SITE PLAN - ELECTRICAL E-102 ENLARGED SITE PLAN - ELECTRICAL E-201 FIRST FLOOR PLAN - LIGHTING E-202 FIRST FLOOR PLAN - POWER E-203 FIRST FLOOR PLAN - SIGNAL E-204 FIRST FLOOR PLAN - FIRE ALARM E-301 SECOND FLOOR PLAN - LIGHTING E-302 SECOND FLOOR PLAN - POWER E-303 SECOND FLOOR PLAN - SIGNAL E-304 SECOND FLOOR PLAN - FIRE ALARM E-401 ROOF PLAN - ELECTRICAL 25 10- PLUMBING P-001 LEGENDS, NOTES, AND SCHEDULES P-101 PLUMBING SITE PLAN P-111 FIRST FLOOR PLAN P-112 SECOND FLOOR PLAN P-131 ROOF PLAN P-411 ENLARGED FLOOR PLAN P-511 PLUMBING DETAILS 7 11- FIRE PROTECTION FP-001 SITE PLAN & NOTES FP-002 FIRST FLOOR PLAN FP-003 SECOND FLOOR PLAN FP-004 BUILDING SECTIONS FP-005 MISCELLANEOUS DETAILS 5 Grand total: 140

EXHIBIT A, continued

19
Volume I total: 51

A - 001 WALL TYPES	
42	
08-MECHANICAL	
M-001	LEGENDS, NOTES, AND SCHEDULES
M-111	FIRST FLOOR PLAN
M-112	SECOND FLOOR PLAN
M-131	ROOF PLAN
M-510	MECHANICAL DETAILS
M-521	VIBRATION ISOLATOR DETAILS
M-601	ENERGY COMPLIANCE FORMS
M-602	ENERGY COMPLIANCE FORMS
M-603	ENERGY COMPLIANCE FORMS
9	
09-ELECTRICAL	
E-001	SYMBOL LIST, ABBREVIATIONS & NOTES
E-002	GENERAL ELECTRICAL NOTES
E-010	FIXTURE LIST & TITLE 24 CALCULATIONS
E-011	TITLE 24 CALCULATIONS - INDOOR LIGHTING
E-012	TITLE 24 CALCULATIONS - OUTDOOR LIGHTING
E-013	TITLE 24 CALCULATIONS - INDOOR LIGHTING
E-014	TITLE 24 CALCULATIONS - OUTDOOR LIGHTING
E-015	LIGHTING CONTROL INFORMATION
E-016	LIGHTING CONTROL INFORMATION
E-020	FIRE ALARM INFORMATION
E-021	FIRE ALARM CALCULATIONS
E-022	FIRE ALARM RISER DIAGRAM
E-030	SINGLE LINE DIAGRAM
E-031	SWITCHBOARD ELEVATIONS
E-040	PANEL SCHEDULES

Exhibit B

Guaranteed Maximum Price (GMP)



SCHEDULE OF VALUES

Marshall Classroom Building
 Oxnard School District
 2900 Thurgood Marshall Dr, Oxnard, CA 93036

GMP
 July 20, 2017

	Description	Recommended Subcontractor	Amount
01570	Erosion Control	Socal Stormwater Runoff Solution	78,677
01730	Surveying	Michael Baker International	20,900
03200	Reinforcing Steel	Vista Steel	96,970
03300	Cast In Place Concrete	Santa Clarita Concrete	413,131
05120	Structural Steel & Misc. Metals	C.A. Buchen	294,133
05700	Ornamental Metals		w/ Struct Steel
06100	Rough Carpentry	JF Construction	1,067,965
06200	Millwork / Cabinetry / Countertops	Dennis Reeves Inc.	34,161
07140	Waterproofing / Traffic Coating	Systems WP	63,636
07200	Insulation	Alcal	47,851
07540	Roofing	Best Contracting	118,535
07600	Sheet Metal / Metal Roofing	Merit Metal Products	160,900
08100	Doors / Frames / Hardware	Construction Hardware	110,110
08800	Glass and Glazing	Santa Barbara Glass	114,087
09220	Plaster & Drywall	Church and Larsen	538,346
09300	Ceramic Tile	Silverado Tile	51,120
09510	Acoustical Ceilings & Wall Panels	Prime Acoustics	48,320
09650	Resilient Flooring and Carpet	Reliable Flooring	69,611
09900	Painting	Vanguard	102,192
10000	Building Specialties	Various	55,645
10110	Visual Display Boards	Nelson Adams Naco Inc.	148,359
10140	Signage	AGS	12,625
10280	Toilet Partitions / Bathroom Accessories	YTI Enterprises	29,000
12240	Window Shades	A1 Quality Blinds	10,000
	Final Cleaning	Commercial Const Cleaning	26,050
14200	Elevators	Republic Elevator	90,220
21000	Fire Sprinkler	J.G. Tate Fire Protection	143,456
22000	Plumbing	City Commerical	355,312
23000	HVAC	Sheldon Mechanical	366,968
26000	Electrical / Low Voltage	Taft Electric	1,177,480
31220	Demo, Earthwork and Site Clearing	Damar Const.	176,464
32122	Asphalt Paving	Onyx Paving	48,580
32131	Site Concrete	B&M Contractors	147,475
32800	Playground Surfaces & Equipment	SpectraTurf / Miracle Playground	100,262
32900	Landscape and Irrigation	Dufau Landscape	81,345



SCHEDULE OF VALUES

Marshall Classroom Building
 Oxnard School District
 2900 Thurgood Marshall Dr, Oxnard, CA 93036

GMP
 July 20, 2017

Description		Recommended Subcontractor	Amount
33000	Site Utilities	Sam Hill & Sons	210,055
01000	Allowances		85,000
	Subguard	1.20%	80,339

Subcontracted Direct Costs			\$ 6,775,280
-----------------------------------	--	--	---------------------

	General Conditions		1,287,702
	General Requirements		3,250
	Subtotal		8,066,232

	Contractor Controlled Insurance Program	1.25%	100,828
	Builders Risk Insurance		By Owner
	General Contractor Bond	0.85%	69,420
	Subtotal		8,236,479

	Contractor Fee	5.00%	411,824
	Subtotal		8,648,303

	Contractor Contingency	4.00%	345,932
--	------------------------	-------	---------

Total Contract Amount			\$ 8,994,236
------------------------------	--	--	---------------------



ALLOWANCES

Marshall Classroom Building
Oxnard School District
2900 Thurgood Marshall Dr, Oxnard, CA 93036

GMP
July 20, 2017

Allowances Included in Proposal		
1	Natural gas service line.	\$ 50,000
2	Furnish and install new Gate G assembly including hardware	\$ 10,000
3	Temporary power during SCE electrical service switch-over in Summer of 2018.	\$ 25,000
TOTAL ALLOWANCES		\$ 85,000



QUALIFICATIONS & ASSUMPTIONS

Marshall Classroom Building

Oxnard School District

2900 Thurgood Marshall Dr, Oxnard, CA 93036

GMP

July 20, 2017

The following items provide additional clarifications regarding the scope of work included in the Proposal:	
1	All Testing and inspection including shop inspection. All testing and inspection will be performed by the authority having jurisdiction or a third party hired by the owner.
2	GMP excludes all permanent connection or use fees by outside utility companies.
3	Settlement surveys of adjacent properties or utilities are excluded.
4	Owner's FFE items - GMP does not include furnishing, installation, unloading / hoisting or storage of Owner's FF&E.
5	Metalworks Linear Faceted/Curved Ceiling system 8" panel per Note 9.03/G-006, see detail 4/A-541 (no sheet A-541 provided) at Elevators, is excluded.
6	Does not include Owner's mobile shelf units, rolling desks, or similar non-fixed furniture.
7	Natural gas service line to new building not shown on Site Utility Plan C-401,402,403,404 or P-sheets is not included, but is addressed by allowance.
8	Using Metal Sales Standing Seam roof in lieu of AEP Span Span-Lock per specifications.
9	Window blinds are not included at the sectional doors, only at the classroom windows even though they are not shown.
10	Epoxy grout is not included at ceramic tile.
11	Vapor emission treatment at concrete floors is not included.
12	TV brackets are OFCI. Televisions or monitors are not included.
13	Specification Section 23 25 00 - Water Treatment is excluded.
14	Hazardous or contaminated soils handling or removal, or removal of any existing underground tanks or appurtenances, is excluded.
15	No standing guard service is included for school site during the Edison rework of the main power. District to provide guard service.
16	Existing handball walls will be demolished (total of 5). GMP does not include any replacement of these ball walls.
17	GMP does not include any seal and re-stripe of existing asphalt play courts - not shown on plans.

VALUE ENGINEERING COST TRACKING LOG

Marshall Classroom Building

Oxnard School District

2900 Thurgood Marshall Dr, Oxnard, CA 93036

July 19, 2017

CCD Required	NO	COST TRACKING DESCRIPTION	NEXT ACTION/STEP/COMMENTS
		Building	
CCD	ARC.1	Replace 8'6"x13' sectional roll up doors with smaller sized aluminum glazed window frames and plaster walls	<p>JA to prepare elevation replace (10) sectional OH doors with windows in punched openings of a plaster wall and drywall wall</p> <p>Update 06/23/17: Sketched due 06/30/17</p> <p>Update 7/6/17: Sketches received from CSDA and circulated to subs for pricing. Requested responses by no later than 7/10/17.</p> <p>Update 7/18/17: Clarification to aluminum window type and glass type received from CSDA and subs have provided their proposals.</p>
CCD	ARC.2	Eliminate Smoke Containment doors at elevators, possibly not required	<p>JA to call FLS plan checker to determine if these can be eliminated.</p> <p>Update 06/23/17: CCD-A to delete smoke doors shall be prepared by 06/30/17 and submitted when DSA Box is set up.</p>
	ARC.3	Eliminate sliding markerboards, keep recessed wall space for mobile shelf units.	<p>After discussion with the team this part of the programmatic design which cannot be eliminated. TM to work with bidders on how to reduce the cost of the current design</p> <p>Update 06/23/17: TM is working with Nelson Adams to achieve projected savings without impacting this programmatic element</p> <p>Update 7/6/17: Revised pricing received from Nelson Adams for sliding markerboards @ 6' in height, same widths as shown on interior elevations. VE credit combined with ARC.4</p> <p>Additional cost for painting exposed wall surfaces are combined with ARC.3</p>
	ARC.4	Decrease size of floor to ceiling markerboard and tackboard surfaces	<p>JA to prepare revised elevation to reduce the height of the wall mounted markerboards and acoustical tackboard</p> <p>Update 06/23/17: TM is working with Nelson Adams to achieve projected savings without impacted this programmatic element</p> <p>Update 7/6/17: Revised pricing received for wall markerboards @ 6' in height, same widths as shown on interior elevations. VE credit combined with ARC.3</p> <p>Additional cost for painting exposed wall surfaces are combined with ARC.3.</p> <p>Update 7/7/17: Jeremy C. provided clarification that sliding markerboards will not change in size. Carl will follow up with Nelson Adams to revise their VE proposal based on this information.</p> <p>Update 7/18/17: Revised pricing received from Nelson Adams. All sliding markerboards remain full height as shown on the drawings, wall markerboards and tackboards will become 6' in height.</p>
	ARC.5	Eliminate acoustical wall panels in upper clerestory areas	<p>JA to revise RCP to delete acoustical wall panels in upper clerestory. JA to incorporate use of acoustical ceiling panels on vertical surfaces.</p> <p>Update 06/23/17: SB directed JA to delete acoustical wall panels in the clerestory walls. TM to confirm \$30K saving</p> <p>Update 7/6/17: Credit provided for deleting these panels in the clerestory wall areas. Additional cost for painting exposed wall surfaces are also provided.</p>
	ARC.6	Eliminate wall tile behind lockers in Rooms 111 & 114.	<p>After discussion with the team it was determined that all tile will be eliminated from the scope of work in the changing rooms. See ARC.18 below</p>
	ARC.7	Lower height of wainscot tile in restrooms to 4' high	<p>RS to provide pricing for proposed revision</p> <p>Update 06/23/17: Pricing for credit received from Silverado Tile.</p>
	ARC.8	Eliminate floor tile in Toilet and changing rooms. Replace with a sealed concrete finish.	<p>See ARC 18 below</p>

VALUE ENGINEERING COST TRACKING LOG

Marshall Classroom Building

Oxnard School District

2900 Thurgood Marshall Dr, Oxnard, CA 93036

July 19, 2017

CCD Required	NO	COST TRACKING DESCRIPTION	NEXT ACTION/STEP/COMMENTS
	ARC.9	Replace entire roof with hot mop- Roofing VE Items	RS to provide pricing for hot mop roof through out the project. Update 06/23/17: TM working with Best Interior to develop a value engineering package that retains the existing design. Update 7/6/17: CM has discussed potential VE items with Best, including use of a lighter gauge standing seam roofing material. Update 7/18/17: Use of a lighter gauge standing seam roofing material is not acceptable to CSDA. Best Contracting looked again at their number and submitted a credit amount.
CCD	ARC.10	Use standard Hydraulic elevators in lieu of MRL elevator	JA to provide revised design for using a jack less hydraulic elevator Update 06/23/17: SB directed team to pursue the hydraulic elevator. TM to forward shop drawing for hydraulic elevator to JA for coordination with designed structure for the shaft and equipment room Update 7/6/17: Republic Elevator has provided drawings for space requirements of the elevator shaft and machine room. CSDA has reviewed and indicates that required space requirements will work within current designed structure.
	ARC.11	Delete energy management system.	RS to obtain credit to delete EMS in it entirety Update 06/23/17: Sheldon provided credit.
	ARC.12	Delete fire department ladders	JA to call fire marshal to understand requirement of exterior fire ladders Update 06/23/17: JA and TM to visit fire department to delete exterior ladders for building and elevator tower Update 7/6/17: Per Jose/CSDA the exterior ladders as shown on G-003 will not be required based on discussion with the local fire department.
CCD	ARC.13	Delete framing at elevator opening smoke doors.	SB accepted deletion. Finalize credit to GMP.
CCD	ARC.14	Delete hand dryers	SB accepted deletion. Finalize credit to GMP JA to revise specifications to include paper towel dispensers Update 06/23/17: Paper towel dispensers shall OFCI.
CCD	ARC.15	Revise Guardrail Detail	JA to review design of handrail detail and revise to simplify and reduce cost. Also see ARC.19 below Update 06/23/17:CA Buchen provided revised design for guardrails which was accepted by SB and JA. Credit provided by CA Buchen.
	ARC.16	Use thinset in lieu of mortar set tile	After discussion with the team it was determined that the mortar bed would be deleted at 1st and 2nd floor restrooms and that the tile would be thinset. Need to add the sloping of floor to drains. RB to provide pricing Update 06/23/17: Credit provided by Silverado.
CCD	ARC.17	Remove 2nd floor canopy over walkways	JA to review the shading study and determine if a portion of the walkway cover can be reduced Update 06/23/17: Still pending structural engineer response. JA to follow on 06/26/17 Update 7/6/17: Jose/CSDA has been working with the structural engineer for drawings/details in order for Bernards to request subcontractor pricing. Update 7/18/17: The structural engineer provided drawings on 7/18/17 for subs to review and provide pricing.
	ARC.18	Delete all tile from change rooms and provide painted walls and resilient tile with rubber base	RS to provide pricing for proposed revisions. Update 06/23/17:Credit provided by Silverado.
	ARC.19	Delete galvanized finish for stairs, guardrails and handrails and provide zinc primer with paint finish	RS to provide pricing for proposed revisions. Update 06/23/17: Steel contractor stated the is no cost difference with zinc coating and galvanizing.

VALUE ENGINEERING COST TRACKING LOG

Marshall Classroom Building

Oxnard School District

2900 Thurgood Marshall Dr, Oxnard, CA 93036

July 19, 2017

CCD Required	NO	COST TRACKING DESCRIPTION	NEXT ACTION/STEP/COMMENTS
	ARC.20	Delete requirement of waterproof wrap around building	JA to review specification to determine what is required and RS to reach out to plaster subcontractors to determine what is included Update 06/23/17: TM got price to wrap the first 5 feet of the building.
	ARC.21	Delete drywall soffit at high ceiling and provide T-Bar and acoustical tile.	JA to prepare sketch of proposed T-Bar soffit for final pricing Update 7/6/17: Jose/CSDA has rejected this potential VE item.
	ARC.22	Revise operable windows to fixed windows	JA to revise specification for windows. TM to price Update 7/6/17: Jose/CSDA has revised the aluminum window spec and pricing has been requested from subcontractor. Update 7/18/17: CSDA revised the aluminum window spec. again and answered subcontractor questions. Subcontractor has provided credit for fixed windows in place of operable.
	ARC.23	Flush Aluminum Windows with Exterior wall	JA to revise specification for windows. TM to price Update 7/6/17: Jose/CSDA has revised the aluminum window spec and pricing has been requested from subcontractor. Update 7/18/17: CSDA revised the aluminum window spec. again and answered subcontractor questions. Subcontractor has provided credit for fixed windows in place of operable. JA to revise detail for window install. TM to price Update 7/6/17: Jose/CSDA has revised the aluminum spec and pricing has been requested from subcontractor. Update 7/18/17: CSDA revised the aluminum window spec. again. Window width is now 4 ½" but still held to outside with return on inside of wall.
	ARC.24	HVAC VE Items	Meeting with CFW, Bernards and Sheldon Mechanical to discuss potential VE items. Items include deduct for standalone control system vs. DDC control system, deduct to change side discharge rooftop units to down shot, deduct to change ductwork from rectangular to round and added cost to install copper coils on rooftop units. Update 7/7/17: The copper fin added cost has been rejected. The (3) credit items are still under consideration. Jose A. to follow up with mechanical engineer to question why his response to down shot roof top units will not work. Update 7/18/17: Mechanical engineer has rejected the proposed down shot type units due to space limitations. Credits for standalone control system and use of round ducts will be accepted.
	ARC.25	Electrical VE Items	Taft Electric has been contacted regarding potential VE items and have submitted the following; Deduct for alternate light fixture package using a different manufacturer, deduct for use of MC cables for all branch circuits in lieu of flex conduit, deduct for use of aluminum brass in lieu of copper on all switchgear, deduct for use of native soil in lieu of concrete backfill at ductbanks. The Electrical Engineer has reviewed and provided a response, to be reviewed further with CFW & CSDA. Update 7/7/17: After reviewing the electrical VE items it was determined to still pursue the potential cost savings of an alternate lighting package and also request a cost savings number for use of slurry backfill in ductbank trenches. Update 7/18/17: Potential cost savings for the alternate lighting package is acceptable. Taft Electric confirmed no savings for use of slurry backfill in ductbank trenches.

VALUE ENGINEERING COST TRACKING LOG

Marshall Classroom Building

Oxnard School District

2900 Thurgood Marshall Dr, Oxnard, CA 93036

July 19, 2017

CCD Required	NO	COST TRACKING DESCRIPTION	NEXT ACTION/STEP/COMMENTS
	ARC.26	Door Hardware Savings (hinges, etc.)	Scott B. requested a door hardware cost savings for use of butt hinges instead of the specified continuous hinges. Scott will forward a copy of District hardware standards to Carl for discussion with the subcontractor for any potential savings.
	ARC.27	Plumbing VE Savings	Carl M. will contact the low bid plumbing subcontractor to discuss any potential cost saving items.
	SIT.1	Eliminate construction of (5) CIP concrete seat benches, District to provide benches	SB accepted deletion. Finalize credit to GMP Update 7/6/17: Credit for deleted concrete benches requested from subcontractor. Update 7/18/17: Credit proposal received from subcontractor.
	SIT.2	Remove PCC Pavers and concrete sub-slab for pavers, leave existing AC paving.	SB accepted deletion. Finalize credit to GMP Update 7/6/17: Credit for deleted concrete pavers and sub slab requested from subcontractor. Update 7/18/17: Credit proposal received from subcontractor.
CCD	SIT.3	Remove raised planter walls - concrete, rebar, waterproofing and landscaping & irrigation	After discussion it was determined to eliminate all raised planters but retain all landscaping at grade. RS to finalize credit for deletion of raised planters JA to provide revised design for landscaping at grade for pricing Update 7/18/17: Credit proposal received from subcontractors for deleted raised planters. Revised landscape drawings not provided, no change in cost proposed for landscaping at planters.
CCD	SIT.4	Remove concrete mow strip, replace with natural grass	JA to review with DSA the need to 6' mow strip with plan checker Update 06/23/17: JA to submit CCD to delete 6' mow strip Update 7/6/17: Pricing has been requested from subcontractor for revising mow strip from 60" to 12" wide. Update 7/18/17: Credit proposal received from subcontractor.
	SIT.5	Delete gravity wall, use curb	JA to review with Civil if gravity wall can be deleted. This would me budget funds to delete the demolition of the ball walls could be removed. Update 06/23/17: JA to confirm with civil engineer that gravity wall can be deleted. Update 7/7/17: This potential VE item has now been rejected.
	SIT.6	Delete perimeter curb & 4" CAB w/ geo fabric at rubber play surface, install rubber surfacing	Rejected
	SIT.7	Delete site concrete mock-up	SB accepted deletion. Finalize credit to GMP
	SIT.8	Reduce cost reconstruction at new electrical service	JA to have civil engineer provide demo and construction for new electrical service. Update 7/6/17: Site photos of the area for SCE work and approximate electrical underground pathway back to the electrical room have been provided to CSDA for use by Civil Engineer. Update 7/7/17: Carl M. will go back into the GMP and verify if there are still potential costs available. Update 7/18/17: After reviewing costs again with estimators, a cost savings was determined.



VALUE ENGINEERING COST TRACKING LOG

Marshall Classroom Building

Oxnard School District

2900 Thurgood Marshall Dr, Oxnard, CA 93036

July 19, 2017

CCD Required	NO	COST TRACKING DESCRIPTION	NEXT ACTION/STEP/COMMENTS
	SIT.9	Gas Line Revisions	<p>Meeting with Gas Company and Engineer to resolve missing gas design took place on 6/26/17 with the So Cal Gas representative. The rep is currently investigating in house on pipe capacity and meter and will report back to Team. There is the possibility that the meter will need to be upsized, which will be a cost to the School District.</p> <p>Update 7/7/17: Jose A. will request that plumbing engineer contact the Gas Co. rep to receive information in order to make final decision.</p> <p>Update 7/18/17: The Gas Company representative has been contacted by Bernards on numerous occasions for an update with no response. CSDA's plumbing engineer is also awaiting a return call. With no clear response to date from Gas Co. this potential VE credit will be rejected. The 50K allowance will continue to be carried in the GMP.</p>

Bid Evaluation Report



Erosion Control

Marshall Classroom Building

Subcontractors

Job Number **1641**
 Bid Date **6/7/2017**
 Date Printed **7/27/2017**

Description	Whitson CM / Bernards	Social Stormwater Runoff Solution			
Base Bid	See below	See below			
Spec # : 312500	Included	Included			
Bond Rate (if required)					
Furnished, Installed, FOB Jobsite, Tax Included	Included	Included			
Plans and Specs Dated: 1/28/2016 & 10/4/2016	Included	Included			
Acknowledgment of RFIs 1-75 dated 6.5.17	Included	Included			
Bid Good for 60 Days	Included	Included			
Prevailing Wage	N/A	N/A			
Prequalified per Oxnard School District Standards	N/A	N/A			
Attachment C Acknowledgement	N/A	N/A			
Storm Water Compliance	1,200	520			
"Due to the project being under 1 acre this project is not subject to the State CGP"	Included	Included			
Provide project related Water Pollution Control Program (WPCP) by Qualified developer	Included	Included			
Development of project specific Best Management Practices (BMP's)	Included	Included			
Development of erosion control plan for inclusion in WPCP	Included	Included			
SWPPP (QSP/QSD) Services					
Qualified SWPPP Practitioner QSP conduct weekly site inspections, photos, document, etc	18,720	10,400			
Rate per week for monitoring	\$360/wk	\$200/visit			
Keep records & documents updated	Included	Included			
Provide recommendations for reqs of BMP upkeep & maintenance (but won't do the work)	Included	Included			
Electronically file all data for Permit documents as required	Included	Included			
Pre/During/Post Rain-Event Visual Inspections	4,320	2,640			
Rate per week/visit for monitoring the rain monitoring	\$360/wk	\$220/visit			
Erosion Control - No Plans Provided					
Silt Fencing at perimeter of sites	21,402	21,402			
Fiber Rolls at perimeter of existing parking lot rework - A-102	Included	Included			
Fiber Rolls at new school addition perimeter - G-003	Included	Included			
Fiber Rolls at new playground area perimeter - G-003	Included	Included			
Construction Entrances	Included	Included			

Bid Evaluation Report

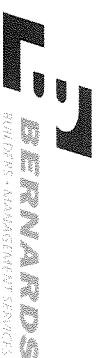

Erosion Control

Marshall Classroom Building

Subcontractors

Job Number: 1641
 Bid Date: 6/7/2017
 Date Printed: 7/27/2017

Description	Whitson CM / Bernards		Social Stormwater Runoff Solution					
	Included	Included	Included	Included				
Storm Drain Inlet Protection	Included	Included						
SWPPP & BMP Implementation	Included	Included						
SWPPP & BMP Implementation - Removal at completion of project	Included	Included						
QSP Monitoring	See below	See below						
Laydown/Trailer Area Erosion Control:	20,985	20,985						
Fiber Rolls at perimeter of existing grass field for trailer/parking/laydown/storage use during construction	Included	Included						
Geofabric over the grass, rock surface	Included	Included						
Removal of above at project completion	Included	Included						
Temporary Construction Fencing & Gates - Bernards	22,730	22,730						
Temp Fencing at existing parking lot rework, 1-side use existing fencing along the creek - A-102, install, maintain, removal	Included	Included						
Temp Fencing at new school addition perimeter - G-003	Included	Included						
Temp Fencing at new playground area perimeter - G-003	Included	Included						
Gates	Included	Included						
TOTALS	89,357	78,677	0	0	0	0	0	0
Recommendation:	Amount							
Social Stormwater Runoff Solution	78,677							

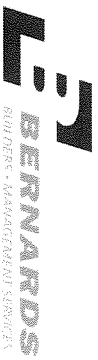

Bid Evaluation Report

Surveying

Marshall Classroom Building

Subcontractors

Description	Adkan Engineers	Brenner & Carpenter	Hunsaker & Associates	MNS Engineers	Job Number	1641
					Date Printed	7/27/2017
					Bid Date	6/7/2017
					Michael Baker International	Stantec
Base Bid	22,000	25,000	60,400	17,055	8,900	39,950
Spec #: 00700 - General Conditions	Included	Included	Included	Included	Included	Included
Bond Rate (if required)	N/A	N/A	N/A	N/A	N/A	N/A
Furnished, Installed, FOB Jobsite, Tax Included	Included	Included	Included	Included	Included	Included
Plans and Specs Dated: 1/28/2016 & 10/4/2016	Included	Included	Included	Included	Included	Included
Acknowledgment of RFIs 1-75 dated 6.5.17	Included	Included	Included	Included	Included	Included
Bid Good for 60 Days	Included	Included	Included	Included	Included	Included
Prevailing Wage	Included	Included	Included	Included	Included	Included
Prequalified per Oxnard School District Standards	N/A	N/A	N/A	N/A	N/A	N/A
Attachment C Acknowledgement	N/A	N/A	N/A	N/A	N/A	N/A
Set-up	Included	Included	Included	Included	Included	Included
Travel Costs	Included	Included	Included	Included	Included	Included
Horizontal Control	Included	Included	Included	Included	Included	Included
Survey Boundary Map	Included	Included	Included	Included	Included	Included
Excavation	Included	Included	Included	Included	Included	Included
Rough Grade Staking	Included	Included	Included	Included	Included	Included
Blueprint Stakes at Bottom of Excavation for Fine Grading	Included	Included	Included	Included	Included	Included
Gridlines at Elevator & Exterior Stairs	Included	Included	Included	Included	Included	Included
Buildings	Included	Included	Included	Included	Included	Included
Building Corner Stakes (All Bids)	Included	Included	Included	Included	Included	Included
Utility Sleeve Layout for Sanitary Sewer, Storm Drain, Domestic and Fire Water, Natural Gas and Permanent Electrical Service	Included	Included	Included	Included	Included	Included
Final Verification Upon Project Completion	Included	Included	Included	Included	Included	Included
Site	Included	Included	Included	Included	Included	Included
Stakes for Sanitary Sewer, Storm Drain, Natural Gas and Domestic Fire & Domestic Water	Included	Included	Included	Included	Included	Included
Line and Grade Stakes for Underground Electrical Devices, POCs and Duct Banks	Included	Included	Included	Included	Included	Included
Line Stakes for demo/saw cut of asphalt at existing northeast parking lot. Provide markings for new parking stalls.	Included	Included	Included	Included	Included	Included
Line and grade stakes for rubberized playground area	Included	Included	Included	Included	Included	Included
1-person survey crew rate per hour	\$185/hr		\$192/hr	\$180/hr	Included	Included
2-person survey crew rate per hour	\$260/hr		\$234/hr	\$260/hr		
	5,000	2,000		6,667	12,000	
TOTALS	27,000	27,000	60,400	23,722	20,900	39,950
Recommendation:	Amount					
Michael Baker International	20,900					

Bid Evaluation Report

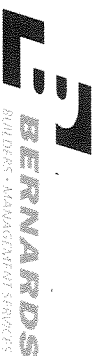

Reinforcing Steel

Marshall Classroom Building

Subcontractors

Job Number **1641**
 Bid Date **6/7/2017**
 Date Printed **7/27/2017**

Description	Upland Contracting		Vista Steel		Subcontractors		Job Number	Bid Date	Date Printed	
Base Bid										
Spec # : 032000	85,814	Included	83,445	Included						
Bond Rate (if required)										
Furnished, Installed, FOB Jobsite, Tax Included										
Plans and Specs Dated: 1/28/2016 & 10/4/2016										
Acknowledgment of RFIs 1-75 dated 6.5.17										
Bid Good for 60 Days										
Prevailing Wage										
Pregualified per Oxnard School District Standards										
Attachment C Acknowledgement										
Rebar										
New Classroom Addition Building per Structural, Architectural & Civil sheets										
Rebar for Footings										
Rebar for Spread Footings										
Rebar for Column Footings										
Rebar for Stair Footings										
Rebar for Pad Footings										
Rebar for Elevator Pit										
Rebar for Slab on Grade										
Hoisting as Required										
Note 15 - Planter Wall per Architectural & Structural drawings - 2 shown near stairs are NOT on S sheets, 36'x8', build them sim to right side of det 6/S-401	5,000		5,000							
Site Concrete Reinforcing	24,486		12,025							
Paving, curbs, seat walls, planter walls										
Site curbs FOB jobsite										
SIT.3										
TOTALS	111,800		96,970		0	0	0	0	0	
Recommendation:										
Vista Steel	Amount		96,970		0		0		0	

Bid Evaluation Report



Building Concrete

Marshall Classroom Building

Subcontractors

Description	Barcelo Construction	Santa Clarita Concrete	Job Number	Bid Date	Date Printed
Base Bid	386,879	395,600			
Spec #: 03 1000 - Concrete Forming Accessories	Included	Included			
Spec #: 03 2000 - Concrete Reinforcing	Included	Included			
Spec #: 03 3000 - Cast-In-Place Concrete	Included	Included			
Bond Rate (if required)		Bond @ 1%			
Furnished, Installed, FOB Jobsite, Tax Included	Included	Included			
Plans and Specs Dated: 1/28/2016 & 10/4/2016	Included	Included			
Acknowledgment of RFIs 1-75 dated 6.5.17	Included	Included			
Bid Good for 60 Days	90 Days	30 Days			
Prevailing Wage	Included	Included			
Prequalified per Oxnard School District Standards	N/A	N/A			
Attachment C Acknowledgement	N/A	N/A			
Structural Concrete					
Typical SOG Underlayment Detail 14/S-400A:	Included	Included			
4" layer crushed rocks Subbase over prepared subgrade	Included	Included			
Base - 2" Sand Fill over crushed rock	Included	Included			
15 mil. Vapor Barrier by Stego Ind. Over sand	Included	Included			
5" SOG	Included	Included			
Reinforcing steel furnish & install, included w/ CIP concrete bid	Excluded	Excluded			
Reinforcing steel furnish & install, separate Rebar Bid	w/ Rebar	w/ Rebar			
Install Anchor/Sill Bolts for Wood Framing per Wall Framing Details - S-401	Included	Included			
Spread Footings per Schedule on Foundation Pages S-401,402,403 (WF-1, WF-2 & F3)	Included	Included			
24" X 18" Conc Footing at Stairs per 1/S-700B	Included	Included			
Tie Rod Brace detail and concrete blockout at Baseplates - 3/S-700B	Included	Included			
1-6" thk Mat slab at Elevator Pit per 12/S-700A	Included	Included			
Elevator Pit wall 10" thk per 12/S-700B	Included	Included			
Site Control Plan C-201					
Note 15 - Planter Wall per Architectural & Structural drawings - 2 shown on S-211 & 6/S401, are part of the building construction	30,000	Included			
Note 15 - Planter Wall per Architectural & Structural drawings - 2 shown near stairs are NOT on S sheets, 36'x8'	30,000	26,600			
Install Guiderail baseplates per 16/S-700B	Included	Included			
Lt Wt Concrete Fill at Balconies & Classrooms on 2nd Floor per Note 7A & 7B/S212 - 1-1/2" twt concrete topping	Included	Included			

Bid Evaluation Report

Building Concrete

Marshall Classroom Building

Subcontractors

Description	Barcelo Construction		Santa Clarita Concrete		Job Number	Bid Date	Date Printed
	Barcelo Construction	Santa Clarita Concrete	Santa Clarita Concrete	Barcelo Construction			
SCC: Deck to be poured prior to construction of walls, otherwise add for another pump system & hoseman to place concrete	Included	6,500			1641	6/7/2017	7/27/2017
Concrete Fill at Pan Filled Metal Stair Treads and Landings w/ W4x4 Reinforcing - 2&6/S-700B	Included	Included					
Balco Stair Strips per keynote 05.03 sheet A-420 & detail 11/A-560	2,500	2,500					
2" contrasting strip, abrasive strip	Included	Included					
6" Upturned CIP concrete base w/ tooled radius at lockers - 14 & 15/A-530	Included	Included					
Depressed slabs at restrooms for ceramic tile work, not shown properly	Included	Included					
Trench Drain concrete basin per 4/S-400A	w/ Site Utilities	w/ Site Utilities					
Other Items:	Included	Included					
All Reinforcing Steel for your work	w/ Rebar	w/ Rebar					
Dewatering as Required	Included	Included					
Setting Anchor Bolt Templates	Included	Included					
Safety walk and progressive cleanup	4,640	4,640					
Curing and Sealing Compounds per Specs as Required	Included	Included					
Drypacking baseplates	1,000	Included					
Base plates for Round HSS and Square HSS per 18/S-401	Included	Included					
Clean up to debris bins	5,100	5,100					
Wash Out Bins	2,500	2,500					
Depressed floors at 1st floor RR's (include, they aren't shown) for ceramic tile install	5,000	5,000					
Spoils removal	approx 325cy	approx 325cy					
SIT.3	(8,700)	(8,709)					
SIT.3	(30,000)	(26,600)					
TOTALS	428,919	413,131	0	0	0	0	0
Recommendation:	Amount						
Santa Clarita Concrete	413,131						

Bid Evaluation Report



Structural Steel

Marshall Classroom Building

Subcontractors

Description	C.A. Buchen	Rincon Ironworks	Metal Supply, Inc.	ACSS	Job Number	1641
					Bid Date	6/7/2017
					Date Printed	7/27/2017
Base Bid	See below	See below	See below	No Bid		
Spec #: 05 1200 - Structural Steel Framing	Included	Included	Included			
Spec #: 05 5000 - Metal Fabrications	Included	Included	Included			
Bond Rate (if required)						
Furnished, Installed, FOB Jobsite, Tax Included	Included	Included	Included			
Plans and Specs Dated: 1/28/2016 & 10/4/2016	Included	Included	Included			
Acknowledgment of RFIs 1-75 dated 6.5.17	Included	Included	Included			
Bid Good for 60 Days	14 Days	Included	Included			
Prevailing Wage	Included	Included	Included			
Prequalified per Oxnard School District Standards	N/A	N/A	N/A			
Attachment C Acknowledgement	N/A	N/A	N/A			
Structural Steel						
New Classroom Building	165,450	234,955	304,688			
HSS Steel Columns, C1, C2, C3, C4 & C5 on First & Second Levels -5" round, 5x5 7x5, 10x8, & 7x7	Included	Included	Included			
HSS Beams at 1st & 2nd floors per floor plans	Included	Included	Included			
HSS Beams at Elevator - 3 each HSS 12x4 tubes per sketch in RFI #3	Included	Included	Included			
Include added 3rd steel column	7,500	7,500	7,500			
HSS Columns & beams at wall elevation S-600E & 19&20/S-600F	Included	Included	Included			
HSS columns in stud walls to have welded studs - 13/S-700	Included	Included	Included			
Base plates for Round HSS and Square HSS per 18/S-401	Included	Included	Included			
"C" Channel Framing at Elevator - S111	Included	Included	Included			
"W" Steel Beams at Elevator - 1/S-700A & 17/S-700A	Included	Included	Included			
Beam to Beam Connection Schedule & details 1/S-700A	Included	Included	Included			
Double angle braces & gusset plate at HSS column at roof transitions 17/S-600D	Included	Included	Included			
1/2" thk x 5" w plate at roof transitions 17/S-600D & 20/S-600E	Included	Included	Included			
Safety Cable Railing as Required - Install, maintain, removal & return to steel sub	3,250	3,250	3,250			
FOB Anchor Bolts/ Templates for Own Work	Included	Included	Included			
FOB Embeds, Weld Plates, etc. for Own Work	Included	Included	Included			
Safety walk and progressive cleanup	3,093	3,093	3,093			
Hoisting for All Work	Included	Included	Included			
Steel Stairs						
Galvanized	122,090	Included	Included			

Bid Evaluation Report

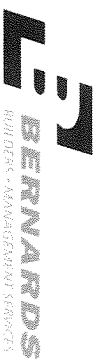

Structural Steel

Marshall Classroom Building

Subcontractors

Description	C.A. Buchen	Rincon Ironworks	Metal Supply, Inc.	ACSS	Job Number	1641
					Bid Date	6/7/2017
					Date Printed	7/27/2017
Stairs 1 & 2 at New Classroom Bldg - S-211,212 & S-700B	Included	Included	Included			
Steel Stairs (Pan Filled Concrete) - A-420	Included	Included	Included			
HSS, MC, C Stringers, L Brackets and Metal Pan Landings	Included	Included	Included			
Conc Nosing at Stairs - included w/ the stairs?	1,250	Included	Included			
Stair Railings and Stair Guardrails	Included	Included	Included			
1-1/2" Handrail Both Sides	Included	Included	Included			
Guardrail at Midlandings	Included	Included	Included			
Guardrail at Top of Stairs	Included	Included	Included			
Stair 1 - 12/S700B	Included	Included	Included			
Stair 2 - 11/S700B	Included	Included	Included			
Railings & Guardrails	Included	132,560	Included	100,000		
2nd Floor New Classroom Bldg - S-212 & 8/S-6001/S-600D	Included	Included	Included			
Deck guardrail detail - HSS2-1/2x2-1/2x3/16 at 4'oc	Included	Included	Included			
Arch drawing sheet A-112, note 5.33, see 15/A-560	Included	Included	Included			
Steel posts & plate top rails, w/ baseplates 8/S-600	Included	Included	Included			
Railing to have a Prefab panel per 10/A-560	Orsogril	Included	Included			
Prefab Panel Elevation detail - 7/A-560	Included	Included	Included			
Railing Inserts per detail 2.3/A-560 - shows 2x1 rect mesh 11 ga galv panel	Included	Included	Included			
Railing Inserts per Spec is diamond mesh	Excluded	Excluded	Excluded			
Misc. Metal	Included	Included	Included			
Steel plate continuous across hoistway ground fl - 5/A-561	2,500	Included	2,500			
Steel plate continuous across hoistway 2nd fl- 7/A-561	2,500	Included	2,500			
Pit ladder 13/A-561, notes states by Elev Mfr, but needs to be w Steel	Included	3,000	Included			
HSS at Canopy connections - 19,20/S-600F	Included	Included	Included			
Elevator Sill Angle & Threshold	Included	Included	Included			
Roof Access Ladders in Electrical rm 206 - A-112, 10/A-500	Included	Included	Included			
Steel ladder mounted to wall mtg all OSHA requirements	Included	Included	Included			
Site	Included	Included	Included			
Steel Bollards at New Electrical Transformer, FOB jobsite, 1/E-102	500	4,000	4,000			
Steel Bollards at New DDCV Assembly, FOB jobsite, C-401 (not shown, include 8 each)	500	4,000	4,000			

Bid Evaluation Report

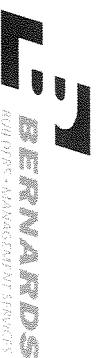

Structural Steel

Marshall Classroom Building

Subcontractors

Description	C.A. Buchen	Rincon Ironworks	Metal Supply, Inc.	ACSS	Job Number	1641
					Bid Date	6/7/2017
					Date Printed	7/27/2017
Fire Department Access Ladder, shown on FLS/Site Plan near grid D&2 SW side - G-003, galvanized	7,500	6,500	7,500			
Fire Department Access Ladder, shown on FLS/Site Plan near grid K&11 near elevator - G-003, galvanized	7,500	6,500	7,500			
ARC.12	(15,000)	(13,000)	(15,000)			
ARC.15	(14,500)	(14,000)	(14,000)			
TOTALS	294,133	378,358	417,531	0	0	0
Recommendation:	Amount					
C.A. Buchen	294,133					



Bid Evaluation Report

Rough Carpentry

Marshall Classroom Building

Subcontractors

Job Number	1641
Bid Date	6/7/2017
Date Printed	7/27/2017

Description	Subcontractors			
	Abdellatif Enterprises	Core Contracting	JF Construction	WS Klem
Base Bid	1,244,000	997,037	922,861	1,156,000
Spec #: 06 1000 - Rough Carpentry	Included	Included	Included	Included
Spec #: 06 1733 - Wood I-Joists	Included	Included	Included	Included
Spec #: 06 1813 - Glue Laminated Beams	Included	Included	Included	Included
Bond Rate (if required)	Bond at 2%	Bond at 2%	Bond at 2%	Bond at 2%
Furnished, Installed, FOB Jobsite, Tax Included	Included	Included	Included	Included
Plans and Specs Dated: 1/28/2016 & 10/4/2016	Included	Included	Included	Included
Acknowledgment of RFIs 1-75 dated 6.5.17	Included	Included	Included	30 days
Bid Good for 60 Days	Included	Included	Included	Included
Prevailing Wage	N/A	N/A	N/A	N/A
Prequalified per Oxnard School District Standards	N/A	N/A	N/A	N/A
Attachment C Acknowledgement	N/A	N/A	N/A	N/A
Rough Framing				
Wall Types Sheet - A-620	Included	Included	Included	Included
Plywood Shear Wall Schedule - S-600	Included	Included	Included	Included
Plywood Sheathing as Shown on Wall Types	Included	Included	Included	Included
Prefabricated plywood web joists "I" Joists per spec section	Included	Included	Included	Included
Open Web Trusses, I-Joists, LVL per Schedule 4/S-600F	Included	Included	Included	Included
MFR - TrusJoist, Red Built or equal	Included	Included	Included	Included
Glue-Laminated Beams & Struc Eng. Beams per spec section	Included	Included	Included	Included
Simpson HDW as Scheduled	Included	Included	Included	Included
Supply Anchor/Sill Bolts for Wood Framing per Wall Framing Details	7,551	7,551	7,551	7,551
Hold Down Schedule 20/S-600	Included	Included	Included	Included
Anchor Rod Schedule - 17/S-401	Included	Included	Included	Included
Mechanical Platforms at Roof 3&5B/S-700B	Included	Included	Included	Included
Wall Framing - 2x4, 2x6, 2x8	Included	Included	Included	Included
Wood Backing for All Wall Items - Millwork, TV's, Marker/Tackboards, Handrails, M.E.P.	Included	Included	Included	Included
Plywood Backboards - Electrical / Low Voltage	3,200	3,200	3,200	3,200
Wood Nailers at Roof Parapet Coping - 2/A-500	Included	Included	Included	Included
Safety Railing as Required at 2nd Floor	5,000	5,000	5,000	5,000
Plywood Floor Sheathing - 19/S-600C	Included	Included	Included	Included
Plywood Roof Sheathing - 19/S600C	Included	Included	Included	Included
1/2" Plywood at Exterior Walls per Struc Walls and Ext. Walls as shown on S-600	Included	Included	Included	Included
Flooring & Roof Joists per Schedule on Framing Plans	Included	Included	Included	Included
1/2" Plywood at Plaster Pilasters	Included	Included	Included	Included

Bid Evaluation Report



Rough Carpentry

Marshall Classroom Building

Subcontractors

Description	Subcontractors				Job Number	Bid Date	Date Printed
	Abdellatif Enterprises	Core Contracting	JF Construction	WS Klem			
Exterior Plywood at Underside of Roof Overhang per 9/A-501	Included	Included	Included	Included	1641	6/7/2017	7/27/2017
Install Pipe Columns per details 2,5,6/S-600D - coordinate w/ Steel sub	Included	Included	Included	Included			
Roof Joists per Schedule on Framing Plans	Included	Included	Included	Included			
Roof Crickets per A-131 - should be w/ roofing, use tapered Insul	Excluded	Excluded	Excluded	Excluded			
Safety walk and progressive cleanup	9,280	9,280	9,280	9,280			
Framing for all recessed items FEC's, etc.	Included	Included	Included	Included			
Blocking & backing for ceilings & duct supports, unknown locations	6,400	6,400	6,400	6,400			
Blocking & backing for roof ladders	600	600	600	600			
Depressed floors at 2nd floor RR's (include, they aren't shown) for ceramic tile install	5,000	5,000	5,000	5,000			
Framing for doors heads & jambs at elevator smoke containment door assembly	4,000	4,000	4,000	4,000			
Fire Treated Lumber	Included	Included	Included	Included			
Storage of Lumber and Delivery to Site	Included	Included	Included	Included			
Hoisting for your work	Included	Included	Included	Included			
All Required Caulking and Sealants for your work	Included	Included	Included	Included			
Scaffolding for Own Work	Included	Included	Included	Included			
Clean-up into your dumpsters	17,000	17,000	17,000	17,000			
Temporary Stairs & ramps	3,000	3,000	3,000	3,000			
Small tools & equipment	3,500	3,500	3,500	3,500			
Security guard	40,200	40,200	40,200	40,200			
Site Security/Alarm/Camera systems	15,477	15,477	15,477	15,477			
ARC.1	9,500	9,500	9,417	9,500			
ARC.13	(4,000)	(4,000)	(4,000)	(4,000)			
ARC.17	(30,000)	(30,000)	(30,521)	(30,000)			
Budget for Lumber Cost Increase	65,000	50,000	50,000	50,000			
TOTALS	1,404,708	1,142,745	1,067,965	1,301,708	0	0	
Recommendation:	Amount						
JF Construction	1,067,965						



Bid Evaluation Report

Cabinets / Millwork

Marshall Classroom Building

Subcontractors

Description	Subcontractors				Job Number	1641
	Bristol Omega	ICI Millwork	K & Z Cabinet	Dennis Reeves Inc.		
Base Bid	47,900	36,107	42,290	34,161	35,270	
Spec # : 06 4000 - Architectural Woodwork	Included	Included	Included	Included	Included	
Spec # : 12 3553 - Manufactured Plastic-Laminate-Faced Casework	Included	Included	Included	Included	Included	
Bond Rate (if required)				Bond at 2.5%		
Furnished, Installed, FOB Jobsite, Tax Included	Included	Included	Included	Included	Included	
Plans and Specs Dated: 1/28/2016 & 10/4/2016	Included	Included	Included	Included	Included	
Acknowledgment of RFIs 1-75 dated 6.5.17	Included	Included	Included	Included	Included	
Bid Good for 60 Days	90 days	90 days	60 days	60 days	45 days	
Prevailing Wage	Included	Included	Included	Included	Included	
Prequalified per Oxnard School District Standards	N/A	N/A	N/A	N/A	N/A	
Attachment C Acknowledgement	N/A	N/A	N/A	N/A	N/A	
Millwork						
Lower Cabinets with Hardware	Included	Included	Included	Included	Included	
Upper Cabinets with Hardware & Locks on all doors per RFI #	Included	Included	Included	Included	Included	
Plastic Laminate Finish	Included	Included	Included	Included	Included	
Plastic Laminate Countertops	Included	Included	Included	Included	Included	
Plastic Laminate Backsplash	Included	Included	Included	Included	Included	
Enlarged Floor Plans - A-410	Included	Included	Included	Included	Included	
Casework details per A-570	Included	Included	Included	Included	Included	
Include the back panel fastening per 2/A-570	Included	Included	Included	Included	Included	
Include the Cont 2-1/2"x2-1/2" x 16 ga bent sheet metal angle anchorage - 6/A-570	Included	Included	Included	Included	Included	
Typical Classroom per 1/A-410	Included	Included	Included	Included	Included	
Casework & Counters	Included	Included	Included	Included	Included	
Rms - 101, 102, 103, 104	Included	Included	Included	Included	Included	
Rms - 201, 202, 203, 204, 207	Included	Included	Included	Included	Included	
Typical Science Classroom per 2/A-410	Included	Included	Included	Included	Included	
Casework & Counters	Included	Included	Included	Included	Included	
Rms - 107, 109	Included	Included	Included	Included	Included	
Performing Arts Lab per 3/A-410	Included	Included	Included	Included	Included	
Casework & Counters	Included	Included	Included	Included	Included	
Rms - 208	Included	Included	Included	Included	Included	
Locker Room Benches	Included	w/ Lockers	w/ Lockers	w/ Lockers	w/ Lockers	
FRP Panels						
	Excluded	Excluded	Excluded	Excluded	Excluded	
TOTALS	47,900	36,107	42,290	34,161	35,270	
Recommendation:	Amount					
Dennis Reeves Inc.	34,161					

Bid Evaluation Report



Waterproofing

Marshall Classroom Building

Subcontractors

Description	Systems WP	Proulx	Santa Barbara Surfacing	Letner	Job Number	1641
					Patriot Contracting	Paul Wolff
					Bid Date	6/7/2017
					Date Printed	7/27/2017
Base Bid	See below	See below	See below	See below	83,560	Incomplete
Spec #: 07 1326 - Self Adhering Sheet Waterproofing	Included	Included	Included	Included	Included	Included
Spec #: 07 8400 - Fire Stop and Smoke Seals	w/ Insulation	w/ Insulation	w/ Insulation	w/ Insulation	w/ Insulation	w/ Insulation
Spec #: 07 9200 - Joint Sealants	Included	Included	Included	Included	Included	Included
Bond Rate (if required)	Included	Included	Bond @ 1.8%	Bond @ 1.5%	Bond @ 1%	Included
Furnished, Installed, FOB Jobsite, Tax Included	Included	Included	Included	Included	Included	Included
Plans and Specs Dated: 1/28/2016 & 10/4/2016	Included	Included	Included	Included	Included	Included
Acknowledgment of RFI's 1-75 dated 6.5.17	Included	Included	Included	Included	Included	Included
Bid Good for 60 Days	Included	90 days	90 days	60 days	60 days	Included
Prevailing Wage	Included	Included	Included	Included	Included	Included
Prequalified per Oxnard School District Standards	N/A	N/A	N/A	N/A	N/A	N/A
Attachment C Acknowledgement	N/A	N/A	N/A	N/A	N/A	N/A
Waterproofing						
Waterproofing at elevator pit 12/A-561	4,100	2,300	8,300	3,510	Included	No Bid
Sheet Waterproofing behind Pit walls	Included	Included	Included	Bituthene 4000	Included	-----
1" drainage board & sheet waterproofing at walls	Included	Included	Included	Included 230 sf	Included	-----
Waterproofing under elev pit SOG (no specs) use bentonite, Grace PrePrufe300R or equal	Included	Included	Included	Included	Included	-----
Elastomeric waterproofing on top of pit slab (no spec) - use crystalline product	1,500	2,500	5,400	2,500	Included	-----
Waterproofing at elevator pit penetrations 8/A-561	Included	Included	Included	Included	Included	-----
Waterproofing of foundation wall at planter areas against the bldg C-300	14,030	18,240	Included	15,000	Included	-----
Waterproofing inside exterior Planters - total of 4 planters 6/S-401	Included	Included 1,920 sf	Included	Included	Included	-----
Waterproofing under topping slabs at 2nd floor decks - 6&7/A-510	18,000	20,000	22,600	20,000	Included	-----
Use 07 1326, self adhering waterproofing OR	Included	Included	Included	Included	Included	-----
Use 60-90mil liquid applied waterproofing w/ 1/8" asphaltic board or drainage mat protection course	Included	Included	Included	Included	Included	-----
Safety walk and progressive cleanup	3,480	3,480	3,480	3,480	3,480	-----
Traffic Coatings						
Per Pre-Bid RFI#4	20,560	22,330	27,050	29,860	Included	No Bid
Installed over 2nd floor exterior deck - 6 & 7/A-510	Included	Included	Included	Included	Included	-----
Installed over exterior stairs and landings - not shown	Excluded	Excluded	Excluded	Excluded	Excluded	-----
Product to be Poly-I-Gard 246SF by Polycoat Products OR	Included	Included 2,552 sf	Included	Excluded	Included	-----

Bid Evaluation Report



Waterproofing

Marshall Classroom Building

Subcontractors

Description	Systems WP				Proulx				Santa Barbara Surfacing				Lethner				Patriot Contracting		Paul Wolff			
	Included	Excluded	Included	Excluded	Included	Excluded	Included	Excluded	Included	Excluded	Included	Excluded	Included	Excluded	Included	Excluded	Included	Excluded				
Product to be Gaco Western, GW-15-U62		2,680		2,680		2,680		2,680		2,680		2,680		2,680		2,680		2,680		1,750		
Interior Concrete Sealed Floors																						
Interior concrete floors shown on Finish Sch A-612 marked F1	Included		Included		Included		Included		Included		Included		Included		Included		Included		Included		Included 676 sf	
No Spec Provided OR see 03300,2.1,G	Included		Included		Included		Included		Included		Included		Included		Included		Included		Included		Augaseal W-20	
Caulking & Sealants																					No Bid	
Per Schedule in Specs	Included		Included		Included		Included		Included		Included		Included		Included		Included		Included		-----	
Windows, Doors, Walls, As Shown	Included		Included		Included		Included		Included		Included		Included		Included		Included		Included		-----	
SIT.3		(10,530)		(10,500)		(10,500)		(10,500)		(10,500)		(10,500)		(10,500)		(10,500)		(10,500)		(10,500)		-----
TOTALS		63,636		70,846		69,996		76,346		89,036		0									0	
Recommendation:	Amount																					
Systems WP	63,636																					



Bid Evaluation Report

Insulation

Marshall Classroom Building

Subcontractors

Description	Subcontractors				Roberts Firestop
	DJ Insulation	Viking Insulation	Alcal	TruTeam/Masco	
Base Bid	26,800	36,892	30,527	26,895	See below
Spec #: 07 2100 - Thermal Insulation	Included	Included	Included	Included	N/A
Spec #: 07 8400 - Fire Stop and Smoke Seals	No Bid	No Bid	No Bid	No Bid	Included
Bond Rate (if required)					
Furnished, Installed, FOB Jobsite, Tax Included	Included	Included	Included	Included	Included
Plans and Specs Dated: 1/28/2016 & 10/4/2016	Included	Included	Included	Included	Included
Acknowledgment of RFIs 1-75 dated 6.5.17	Included	Included	Included	Included	Included
Bid Good for 60 Days	60 Days	Included	30 days	60 days	Included
Prevailing Wage	Included	Included	Included	Included	Included
Prequalified per Oxnard School District Standards	N/A	N/A	N/A	N/A	N/A
Attachment C Acknowledgement	N/A	N/A	N/A	N/A	N/A
Thermal and Blanket Insulation					
Interior, Exterior Walls, Ceilings, Roof	Included	Included	Included	Included	No Bid
R19 & 8" Batts at Int & Ext Walls	Included	Included	Included	Included	-----
R30 at Roof (Not shown)	See below	See below	See below	See below	-----
Walls to Receive Insulation per Wall Types A-620	Included	Included	Included	Included	-----
Wall type A - min 3" sound insulation	Included	Included	Included	Included	-----
Wall type B - double stud walls min 3" sound insulation	Included	Included	Included	Included	-----
Wall type C - min 3" sound insulation	Included	Included	Included	Included	-----
Wall type D - min 3" sound insulation	Included	Included	Included	Included	-----
Wall type E1 - min 3-1/2" foil-faced glass fiber batts	????	Included	Included	Included	-----
Wall type F - Batt insulation	Included	Included	Included	Included	-----
Wall type G - Batt insulation	Included	Included	Included	Included	-----
Wall type H - min 3" sound insulation	Included	Included	Included	Included	-----
Wall type I - min 3" sound insulation	Included	Included	Included	Included	-----
Wall type K - double stud walls Int. Acoustic wall - fiberglass batt insulation	Included	Included	Included	Included	-----
Wall type N - none shown	-----	-----	-----	-----	-----
Wall type O - batt insulation	Included	Included	Included	Included	-----
Rigid Insulation at PVC roofing	w/ Roofing	Included	Included	Included	-----
Rigid Insulation at Standing Seam roofing	Excluded	Included	Included	Included	-----
R-30 insulation at underside of standing seam roofing	7,500	Included	Included	4,965	-----
Fire Stops and Smoke Seals					
Mineral fiber insulation fire safing, damming material, clips and closures	17,324	17,324	17,324	17,324	17,324
Seal openings in floors, fire rated walls & penetrations	Included	Included	Included	Included	Included
At pipes, ducts, conduits & other items shown	Included	Included	Included	Included	Included

Bid Evaluation Report

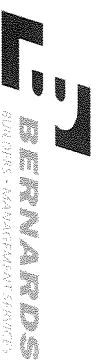

Insulation

Marshall Classroom Building

Subcontractors

Description	DJ Insulation	Viking Insulation	Alcal	TruTeam/Masco	Roberts Firestop	Job Number	1641
						Bid Date	6/7/2017
						Date Printed	7/27/2017
MFR - Bio Fireshield, 3M, GE or Nelson	Included	Included	Included	Included	Included		
Sealants, firestop putty, mortar, pillows, mineral fiber saifing	Included	Included	Included	Included	Included		
TOTALS	51,624	54,216	47,851	49,184	0		0
Recommendation:	Amount						
Alcal	47,851						

Bid Evaluation Report

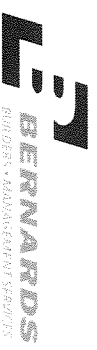

Sheet Metal & Metal Panels

Marshall Classroom Building

Description	R&J SM	Letter	Commercial Roofing	Merit Metal Products	Job Number	
					Date Printed	Valencia Sheet Metal
					1641	
					6/7/2017	
					7/27/2017	
Base Bid	See below	167,950	See below	See below	189,170	103,880
Spec #: 07 4000 - Metal Roof Panels	Included	Included	Included	Included	Included	Included
Spec #: 07 6000 - Flashing Sheet Metal	Included	Included	Included	Included	Included	Included
Bond Rate (if required)	Bond @ 2.5%	Bond @ 1.5%	Bond @ 1%	Bond @ 1%	Bond @ 1%	Bond @ 2%
Furnished, Installed, FOB Jobsite, Tax Included	Included	Included	Included	Included	Included	Included
Plans and Specs Dated: 1/28/2016 & 10/4/2016	Included	Included	Included	Included	Included	Included
Acknowledgment of RFI's 1-75 dated 6.5.17	Included	Included	Included	Included	Included	Included
Bid Good for 60 Days	30 Days	90 days	60 days	60 days	60 days	30 days
Prevailing Wage	Included	Included	Included	Included	Included	Included
Prequalified per Oxnard School District Standards	N/A	N/A	N/A	N/A	N/A	N/A
Attachment C Acknowledgement	N/A	N/A	N/A	N/A	N/A	N/A
Sheet Metal						
Exterior Elevations A-210, A-211; Building Sections A-310, 311, 320, 321, 322	Included	Included	No Bid	8,600	Included	Included
Roof Plan A-131	Included	Included	-----	40,000	Included	40,000
Flexible Flashing and Underlayment	Included	Included	-----	Included	Included	Included
Underlayment Single-ply self adhesive Waterproofing membrane per 09 2200.2.02.K	Included	Included	-----	Included	Included	Included
MFR - WR Grace, Jiffy-Seal or equal	Included	Included	-----	Included	Included	Included
Include membrane behind joints & backing at items exposed to weather, under metal copings & flashings & window jambs & sills per spec	Included	Included	-----	Included	Included	Included
Roof Details Sheet A-500:	Included	Included	-----	Included	Included	Included
Parapet Coping w/ cont cleat both sides - 22 Ga - 2/A-500	Included	Included	-----	Included	Included	Included
Flashing at mechanical unit curbs - 4/A-500 Not clearly shown	Included	Included	-----	Included	Included	Included
Roof penetration at Ducts flashing - 5/A-500	Included	Included	-----	Included	Included	Included
Flash at Pipes penetrations - 6/A-500	Included	Included	-----	Included	Included	Included
Flash at Exhaust duct - 9/A-500	Included	Included	-----	Included	Included	Included
Flash at roof access hatch - 10/A-500	Included	Included	-----	Included	Included	Included
Flash at fascias - 5/A-501	Included	Included	-----	Included	Included	Included
Flash at upper roof exterior soffits - 6/A-501	Included	Excluded	-----	Included	Included	Included
Flash at roof opening details 7/A-501, 20 ga cont cleat	Included	Included	-----	Included	Included	Included
Cap sloped on cement plaster beam 22 ga gsm w/ cont cleats both sides 10/A-510	Included	Included	-----	Included	Included	Included
Door & Window Sill/Head Flashings - 1.2/A-5120	Included	Included	-----	Included	Included	Included
Door head flashing - 10-12/A-520	Included	Included	-----	Included	Included	Included
Metal Corner trims at jambs of Sectional Garage doors - 12/A-521	Included	Included	-----	Included	Included	Included
Balcony Flashing at 2nd Floor deck guardrail - 15/A-560	Included	Included	-----	Included	Included	Included
Roof to plaster conditions	Included	Included	-----	6,400	Included	9,010
Gutters & Downspouts - None Shown	Included	Included	-----	Included	Included	Included

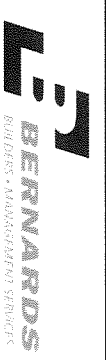

Sheet Metal & Metal Panels

Marshall Classroom Building

Job Number	1641
Bid Date	6/7/2017
Date Printed	7/27/2017
Patriot Contracting	Valencia Sheet Metal

Description	Subcontractors				Job Number	Date Printed	Patriot Contracting	Valencia Sheet Metal
	R&J SM	Letner	Commercial Roofing	Merit Metal Products				
Galvanized, Rectangular Shaped, from flat roofs, not shown	10,000	10,000	-----	10,000	10,000	10,000	Included	Included
Connects to storm drains systems, not shown	Included	Included	-----	Included	Included	Included	Included	Included
Roof Drains are internal pipes by plumber	Included	Included	-----	Included	Included	Included	Included	Included
Mechanical Equipment pad covers - None Shown	N/A	N/A	-----	N/A	N/A	N/A	N/A	N/A
Work at Outside Storage Unit per 07 6000 1.01B.9	N/A	N/A	-----	N/A	N/A	N/A	N/A	N/A
Roof Hatch	7,122	Included	No Bid	Included	Included	Included	Included	Included
Roof Plan A-131, Keynote 07.08 Roof Access Hatch 108.12/A-500, 30"x42" min size	Included	Included	-----	Included	Included	Included	Included	Included
MFR - Acudor, Bilco, Dur-Red, Milcor - Not Listed	Included	Included	-----	Included	Included	Included	Included	Included
Prefab Curb by MFR	Included	Included	-----	Included	Included	Included	Included	Included
Installed in Electrical Room 206	Included	Included	-----	Included	Included	Included	Included	Included
Metal Roofing	159,537	Included	202,181	84,000	Included	Included	Included	Included
Roof Plan A-131, Keynote 07.25 Standing Seam Metal Roof 10/A-501	Included	Included	Included	Included	Included	Included	Included	Included
Typical Standing Mtl roof detail 10/A-5010	Included	Included	Included	Included	Included	Included	Included	Included
MFR AEP Span, SpanLok	Included	Included	Included	Alt Prod: Metal Sales	Included	Included	Included	Alt Prod: Metal Sales
Per Specs call for 20 ga. / All bids are calling for 22 ga., so 22ga is basis of bid	Included	Incl 24ga	Included	Included	Included	Included	Included	Included
30#lb felt underlayment over roof plywood(by others)	Included	Included	Included	Included	Included	Included	Included	Included
Standing seam roof panels fastened w/ 1-1/2" pancake head screws	Included	Included	Included	Included	Included	Included	Included	Included
Flash standing seam at Fascia - 5/A-501	Included	Included	Included	Included	Included	Included	Included	Included
Flash Fascia 2 at standing seam 9/A-501	Included	Included	Included	Included	Included	Included	Included	Included
Gutters & Downspouts - None Shown - at low side of standing seam roofs	Included	Not shown	Included	Not shown	Not shown	Not shown	Not shown	Not shown
Downspouts to be sch40 pipe & galv downspouts to flat roofs	Included	Included	Included	Included	Included	Included	Included	Included
Waste Disposal	3,400	3,400	3,400	3,400	3,400	3,400	3,400	3,400
Provide Alternate Add if not in base bid	-----	14,000	Included	8,500	15,000	9,000		
Wall Louvers								
As listed /shown on Mechanical	w/ HVAC Metal Roof SM	w/ HVAC Metal Roof SM	w/ HVAC Metal Roof Only No SM	w/ HVAC Alt Metal Roof SM	w/ HVAC Metal Roof SM	w/ HVAC Alt Metal Roof SM		
TOTALS	236,257	195,350	205,581	160,900	217,570	175,290		
Recommendation:	Amount							
Merit Metal Products	160,900							

Bid Evaluation Report



Sheet Metal & Metal Panels

Marshall Classroom Building

Subcontractors

Job Number 1641
 Bid Date 6/7/2017
 Date Printed 7/27/2017

Description	Craig Roofing	Chapman Coast			
Base Bid	See below	0			
Spec #: 07 4000 - Metal Roof Panels	Included	SM only			
Bond Rate (if required)	Included	w/roofing bid			
	Bond @ 2.5%				
Furnished, Installed, FOB jobsite, Tax Included	Included				
Plans and Specs Dated: 1/28/2016 & 10/4/2016	Included				
Acknowledgment of RFI's 1-75 dated 6.5.17	Included				
Bid Good for 60 Days	30 Days				
Prevailing Wage	Included				
Prequalified per Oxnard School District Standards	N/A				
Attachment C Acknowledgement	N/A				
Sheet Metal					
Exterior Elevations A-210, A-211; Building Sections A-310, 311, 320, 321, 322	Included	9,550			
Roof Plan A-131	Included				
Flexible Flashing and Underlayment	Included				
Underlayment Single-ply self adhesive Waterproofing membrane per 09 2200.2.02.K	Included				
MFR - WR Grace, Jiffy-Seal or equal	Included				
Include membrane behind joints & backing at items exposed to weather, under metal copings & flashings & window jambs & sills per spec	Included				
Roof Details Sheet A-500:	Included				
Parapet Coping w/ cont cleat both sides - 22 Ga - 2/A-500	Included				
Flashing at mechanical unit curbs - 4/A-500 Not clearly shown	Included				
Roof penetration at Ducts Flashing - 5/A-500	Included				
Flash at Pipes penetrations - 6/A-500	Included				
Flash at Exhaust duct - 9/A-500	Included				
Flash at roof access hatch - 10/A-500	Included				
Flash at fascias - 5/A-501	Included				
Flash at upper roof exterior soffits - 6/A-501	Included				
Flash at roof opening details 7/A-501, 20 ga cont cleat	Included				
Cap sloped on cement plaster beam 22 ga gsm w/ cont cleats both sides 10/A-510	Included				
Door & Window Sill/Head Flashings - 1.2/A-5120	Included				
Door head flashing - 10-12/A-520	Included				
Metal Corner trims at jambs of Sectional Garage doors - 12/A-521	Included				
Balcony Flashing at 2nd Floor deck guardrail - 15/A-560	Included				
Roof to plaster conditions	9,000				
Gutters & Downspouts - None Shown	Included				

Bid Evaluation Report



Sheet Metal & Metal Panels

Marshall Classroom Building

Subcontractors

Job Number 1641
 Bid Date 6/7/2017
 Date Printed 7/27/2017

Description	Craig Roofing	Chapman Coast				
Galvanized, Rectangular Shaped, from flat roofs, not shown	10,000					
Connects to storm drains systems, not shown	Included					
Roof Drains are internal pipes by plumber	Included					
Mechanical Equipment pad covers - None Shown	N/A					
Work at Outside Storage Unit per 07 6000 I.01B.9	N/A					
Roof Hatch	Included					
Roof Plan A-131, Keynote 07.08 Roof Access Hatch	Included					
10&12/A-500, 30"x42" min size	Included					
MFR - Acudor, Blico, Dur-Red, Milcor - Not Listed	Included					
Prefab Curb by MFR	Included					
Installed in Electrical Room 206	Included					
Metal Roofing	218,820					
Roof Plan A-131, Keynote 07.25 Standing Seam Metal Roof 10/A-501	Included					
Typical Standing Mt roof detail 10/A-5010	Included					
MFR AEP Span, SpanLok	Included					
Per Specs call for 20 ga. / All bids are calling for 22 ga., so 22ga is basis of bid	Included					
30#lb felt underlayment over roof plywood(by others)	Included					
Standing seam roof panels fastened w/ 1-1/2" pancake head screws	Included					
Flash standing seam at Fascia - 5/A-501	Included					
Flash Fascia 2 at standing seam 9/A-501	Included					
Gutters & Downspouts - None Shown - at low side of standing seam roofs	Included					
Downspouts to be sch40 pipe & galv downspouts to flat roofs	Included					
Waste Disposal	-----					
Provide Alternate Add if not in base bid						
Wall Louvers	0					
As listed /shown on Mechanical	w/ HVAC Metal Roof SM	No Metal Roof SM Only				
TOTALS	275,928	0	0	0	0	0
Recommendation:	Amount					
Merit Metal Products	160,900					

Bid Evaluation Report



Roofing

Marshall Classroom Building

Subcontractors

Description	Best Contracting	Chapman Coast	Commercial Roofing	Craig Roofing	Letner Roofing	WSP Roofing	Job Number	1641
							Bid Date	6/7/2017
							Date Printed	7/27/2017
Base Bid	124,725	153,939	145,717	199,708	211,750	129,179		
Spec #: 07 5416 - Polyvinyl Chloride (PVC) Roofing (Mechanically Attached)	Included	Included	Included	Included	Included	Included		
Bond Rate (if required)								
Furnished, Installed, FOB Jobsite, Tax Included	Included	Included	Included	Included	Included	Included		
Plans and Specs Dated: 1/28/2016 & 10/4/2016	Bond @ 1%	Bond @ 1.5%	Bond @ 1.5%	Bond @ 1.5%	Bond @ 1.5%	Bond @ 1.5%		
Acknowledgment of RFI's 1-75 dated 6.5.17	Included	Included	Included	Included	Included	Included		
Bid Good for 60 Days	30 days	60 Days	60 Days	45 days	60 Days	Included		
Prevailing Wage	Included	Included	Included	Included	Included	Included		
Prequalified per Oxnard School District Standards	N/A	N/A	N/A	N/A	N/A	N/A		
Polyvinyl-Chloride (PVC) Roofing	Included	Included	Included	Included	Included	Included		
Roof Plan A-131, Keynote 07.01 Single-Ply Roof Assembly see 1/A-500	Included	Included	Included	Included	Included	Included		
MFR - Sika Sarnafil, Johns Manville, Carlisle or Equal	Sarnafil	Carlisle	Sarnafil	Included	Included	Included		
BOD Sarnafil S327 FB, thermoplastic membrane w/ poly reinforcement & feltback membrane	Included	Included	Included	Included	Included	Included		
Single Ply Roofing System 60 mill without fleece backing, color to be White	Included 7,000 sf	Included 6,600sf	Included	Included	Included 7,000sf	Included 7,000sf		
Fully Adhered	Included	Included	Included	Included	Included	Included		
Mechanically Fastened	Included	Included	Included	Included	Included	Included		
R-30 Rigid Isoocyanurate foam Insulation w/ black mat facers	Included	Included	Included	Included	Included	Included		
Tapered crickets w/ Insulation	Included	Included	Included	Included	Included	Included		
1/2" DensDeck Coverboard at Roof	Included	Included	Included	Included	Included	Included		
Include all attachment components & flashing materials	Included	Included	Included	Included	Included	Included		
Include misc flashing at pipes, corners coverstrips, termination bars	Included	Included	Included	Included	Included	Included		
Include all sealants	Included	Included	Included	Included	Included	Included		
Safety walk and progressive cleanup	4,640	4,640	4,640	4,640	4,640	4,640		
Walk Pads - Per Roofing Plans	Included	Included	Included	Included	Included	Included		
Polyester reinforced, 0.096 inch weldable membrane w/ surface embossment per spec 2.07.A	Included	Included	Included	Included	Included	Included		
Parapet walls to be plaster	Included	Included	Included	Included	Included	Included		
Waste disposal	4,250	4,250	4,250	4,250	4,250	4,250		
Warranty to be 10-yr NDL Material & Labor warranty	Included	Included	Included	Included	Included	Included		
ARC.9	(4,800)	(4,500)	(4,500)	(4,500)	(4,500)	(4,500)		
ARC.17	(10,280)	(10,000)	(10,000)	(10,000)	(10,000)	(10,000)		
TOTALS	118,535	148,329	140,107	194,098	206,140	123,569		
Recommendation:	Amount							

Bid Evaluation Report



Roofing		Marshall Classroom Building			Job Number	1641
		Subcontractors			Bid Date	6/7/2017
					Date Printed	7/27/2017
Description	Best Contracting	Chapman Coast	Commercial Roofing	Craig Roofing	Letner Roofing	WSP Roofing
Best Contracting		118,535				

Bid Evaluation Report

Doors, Frames & Hardware

Marshall Classroom Building

Subcontractors

Description	Construction Hardware	Design Hardware	RK&G Construction	Star Hardware	Estrada Hardware	Job Number	1641
						Bid Date	6/7/2017
						Date Printed	7/27/2017
Base Bid	99,420	113,689	132,696	102,265	115,060		
Spec #: 08 1113 - Hollow Metal Doors and Frames	Included	Included	Included	Included	Included		
Spec #: 08 1416 - Flush Wood Doors	Included	Included	Included	Included	Included		
Spec #: 08 3116 - Access Panels & Frames	Included	Included	Included	Included	Included		
Spec #: 08 3613 - Sectional Doors	Included	Included	Included	Included	Included		
Spec #: 08 7100 - Door Hardware	Included	Included	Included	Included	Included		
Bond Rate (if required)	Bond @1.5%	Bond @1.5%	Bond @2.5%				
Furnished, Installed, FOB Jobsite, Tax Included	Included	Included	Included	Included	Included		
Plans and Specs Dated: 1/28/2016 & 10/4/2016	Included	Included	Included	Included	Included		
Acknowledgment of RFI's 1-75 dated 6.5.17	Included	Included	Included	Included	Included		
Bid Good for 60 Days	60 Days	60 Days	30 days	Included	Included		
Prevailing Wage	Included	Included	Included	Included	Included		
Prequalified per Oxnard School District Standards	N/A	N/A	N/A	N/A	N/A		
Attachment C Acknowledgement	N/A	N/A	N/A	N/A	N/A		
Hollow Metal Doors and Frames	Included	Included	Included	Included	Included		
MFR per Specs	Included	Included	Included	Included	Included		
Frame Details - A-520	Included	Included	Included	Included	Included		
New Classroom Building - 1st & 2nd fl	Included	Included	Included	Included	Included		
HM Frames ()	Included	Included	Included	Included	Included		
Type A	Included	Included	Included	Included	Included		
Type B	Included	Included	Included	Included	Included		
Type C	w/ Spec Drs	w/ Spec Drs	w/ Spec Drs	w/ Spec Drs	w/ Spec Drs		
Type D, Marker Board Sliding Door Schedule	Included	Included	Included	Included	Included		
Type E - w/ Louver	Included	Included	Included	Included	Included		
HM Doors (30)	Included	Included	Included	Included	Included		
Wood Doors (3)	Included	Included	Included	Included	Included		
Install HM Doors	Included	Included	Included	Included	Included		
Install HM Frames	Included	8,500	8,500	8,500	6,350		
Install Wood Doors	Included	Included	Included	Included	Included		
Glass for Vision Lites & Windows	3,375	3,750	3,750	3,750	3,375		
Door Hardware	Included	Included	Included	Included	Included		
Hardware per Schedule in Specs	Included	Included	Included	Included	Included		
Safety walk and progressive cleanup	2,320	2,320	2,320	2,320	2,320		
Door Thresholds	Included	Included	Included	Included	Included		
Misc. Door Hardware - Site Gates	Included	Included	Included	Included	Included		
Storefront Doors - None Shown	Included	Included	Included	Included	Included		
Panic Hardware at Gates - per Accessibility Site Plan - G-004	Included	Included	Included	Included	Included		
Hardware at existing Gates per Gate Schedule, G-004	Included	Included	Included	Included	Included		

Bid Evaluation Report



Doors, Frames & Hardware

Marshall Classroom Building

Subcontractors

Description	Construction Hardware	Design Hardware	RK&G Construction	Star Hardware	Job Number	
					Estrada Hardware	1641
					Bid Date	6/7/2017
					Date Printed	7/27/2017
Door G, 520A & 520B - Exit only panic hdwr on push side, key lock on pull side	3,475	5,250	5,250	5,250	3,475	
Doors 5-1, 5-2, 5-6, 514A: Exit only panic hdwr on push side, key lock side	4,690	4,690	4,690	4,690	4,690	
ARC:26	(3,170)	(3,000)	(3,000)	(3,000)	(3,000)	
TOTALS	110,110	135,199	154,206	123,775	132,270	0
Recommendation:		Amount				
Construction Hardware		110,110				

Bid Evaluation Report



Glass & Glazing

Marshall Classroom Building

Subcontractors

Santa Barbara Glass

Center Glass

Coast to Coast

Job Number **1641**
 Bid Date **6/7/2017**
 Date Printed **7/27/2017**

Description	Santa Barbara Glass	Center Glass	Coast to Coast			
Base Bid	79,908	86,300				
Spec #: 08 5113 - Aluminum Windows	Included	Included				
Spec #: 08 7100 - Door Hardware	N/A	N/A				
Spec #: 08 8000 - Glazing	Included	Included				
Bond Rate (if required)						
Furnished, Installed, FOB Jobsite, Tax Included	Included	Included				
Plans and Specs Dated: 1/28/2016 & 10/4/2016	Included	Included				
Acknowledgment of RFIs 1-75 dated 6.5.17	Included	Included				
Bid Good for 60 Days	Included	30 days				
Prevailing Wage	Included	Included				
Prequalified per Oxnard School District Standards	N/A	N/A				
Aluminum Windows	Included	Included				
Double and Single Hung Windows	Included	Included				
Acceptable Manufacturers for Aluminum Windows	Included	Included				
Efco Series 684 & 694	Included	Series 2700				
Traco TR-9000	Included	Excluded				
Graham Series 3000/3100	Included	Excluded				
Peerless Model 4340 & 4140	Included	Included				
New Classroom Bldg - A-111, A-112	Included	Included				
Type A - 5' x 2'-1"	Included	Included				
Type B - 3' x 6'	Included	Included				
Type C - 5' x 6'	Included	Included				
Type D - 5' x 6'	Included	Included				
Type E - 3' x 8'	Included	Included				
Type F - 5' x 8'	Included	Included				
Type G - 5' x 6'	Included	Included				
Type H - 5' x 6'	Included	Included				
Type I - 3' x 6'	Included	Included				
Sealing and Caulking for All Window/Door Systems per Arch Details	3,775	3,775				
Glazing	Included	Included				
Glass for Vision Lites & Windows	3,750	Included				
Include SG - Safety Glazing as Indicated on Window Schedule A-610, per spec 08800	Included	Included				
Include OB - Obscured Glazing as Indicated on Window Schedule A-610, per spec 08800	Included	Included				
Other						
Field Testing for Water Penetration AAMA E1105, assume 6 ea	4,500	4,500				
Mock-Up	1,250	1,250				
ARC.1	24,998	25,000				
ARC.22	(4,094)	(4,000)				
TOTALS	114,087	116,825	0	0	0	0

Bid Evaluation Report



Glass & Glazing	Marshall Classroom Building			Job Number	1641
				Bid Date	6/7/2017
	Subcontractors			Date Printed	7/27/2017
Description				Santa Barbara Glass	Center Glass
	Amount				
Recommendation:	Santa Barbara Glass			114,087	

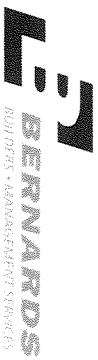

Bid Evaluation Report

Plaster & Drywall

Marshall Classroom Building

Description	Subcontractors				Premier Drywall	Perlite Plastering	Pacific Interiors
	Best Interiors	Standard Drywall	Church and Larsen	Plaster Only			
Base Bid	See Below	See Below	See Below	Drywall Only	Plaster Only	Dywall Only	
Spec #: 07 8400 - Fire Stop and Smoke Seals	Included	Included	Included	N/A	N/A	N/A	
Spec #: 07 9200 - Joint Sealants	Included	Included	Included	N/A	N/A	N/A	
Spec #: 09 2200 - Cement Plastering	Included	Included	Included	N/A	Included	N/A	
Spec #: 09 2900 - Gypsum Board	Included	Included	Included	Included	N/A	Included	
Spec #: 078400, 083100, 072500	Included	Included	Included	N/A	N/A	N/A	
Bond Rate (if required)							
Furnished, Installed, FOB Jobsite, Tax Included	Included	Included	Included	Included	Included	Included	
Plans and Specs Dated: 1/28/2016 & 10/4/2016	Included	Included	Included	Included	Included	Included	
Acknowledgment of RFIs 1-75 dated 6.5.17	Included	Included	Included	Included	Included	Included	
Bid Good for 60 Days	30 Days	30 Dyas	30 Dyas	90 Dyas	30 Dyas	Included	
Prevailing Wage	Included	Included	Included	Included	Included	Included	
Prequalified per Oxnard School District Standards	N/A	N/A	N/A	N/A	N/A	N/A	
Attachment C Acknowledgement	N/A	N/A	N/A	N/A	N/A	N/A	
Plaster	436,210	428,681	289,224	334,700	334,700	334,700	
Exterior Elevations A-210, A-211; Building Sections A-310, 311, 320, 321, 322	Included	Included	Included		Included		
Keystone 09.11-Portland Cement Plaster and Metal Lath, per wall types	Included	Included	Included		Included		
Texture - Dash Bond Coat 09 2200,3,06,G	Included	Included	Included		Included		
Exterior Plaster Ceilings and Soffits per typ det 11/A-501	Included	Included	Included		Included		
Exterior Plaster at parapets 2/A-500	Included	Included	Included		Included		
Interior Plaster per specs, Include if any shown on drawings	Included	Included	Included		Included		
Foam Trim Pieces at Windows if shown to be foam	Included	Included	Included		Included		
Water resistant backing behind metal lath - 09 2200,2,01,E	Included	Included	Included		Included		
Paper Grade D, 60--min rating on wood studs without sheathing, and on plywood sheathing	Included	Included	Included		Included		
Paper Grade B, 16--hour rating on gypsum sheathing	Included	Included	Included		Included		
MFR - Fortifiber, Super Jumbo Tex,USG, Inryco or Western Metal Lath	Included	Included	Included		Included		
2-Layers Grade D Kraft Paper	Included	Included	Included		Included		
3-Coat System	Included	Included	Included		Included		
Glass Fiber Reinforcement	Included	Included	Included		Included		
Lath & Paper	Included	Included	Included		Included		
Ribbed Lath at Plaster Ceilings & Soffits	Included	Included	Included		Included		
Stronghold earthquake staples for metal lath at plaster ceilings & soffits 11/A-501, 16/A-502	Included	Included	Included		Included		
Expansion/Control Joints 9/A-510	Included	Included	Included		Included		
Plaster Trim	Included	Included	Included		Included		

Bid Evaluation Report



Plaster & Drywall

Marshall Classroom Building

Subcontractors

Description	Best Interiors	Standard Drywall	Church and Larsen	Premier Drywall	Job Number	1641
					Date Printed	6/7/2017
Vent & Weep Screeds - 15/A-560	Included	Included	Included		Included	
Corner Bead - 13/A-510	Included	Included	Included		Included	
Ceiling expansion joints - 15/A-510	Included	Included	Included		Included	
Plaster Stops - 5/A-501	Included	Included	Included		Included	
Underlayment Single-ply self adhesive Waterproofing membrane per 09 2200.2.02.K	70,000	62,686	70,000	70,000	70,000	70,000
MFR - WR Grace, Jiffy-Seal or equal	Included	Included	Included		Included	
Include membrane behind joints & backing at items exposed to weather, under metal copings & flashings & window jambs & sills per spec	Included	Included	Included		Included	
Provide vertical Control Joint at each side of the double windows, full ht. south, west and east elevation. Provide horizontal CJ at the bottom of the upper window (aff. +17'-6") to line-up with window sill. Reference details 5 & 9/A-510 (RFI #14)	Included	Included	Included		Included	
All roof parapet walls (interior) and mechanical wall walls to have plaster finish, typical. Ref. detail 2/A-500. (RFI #15)	Included	Included	Included		Included	
Safety walk and progressive cleanup	11,600	11,600	11,600		11,600	
Patching, Taping, Floating as Required	Included	Included	Included		Included	
All Required Caulking and Sealants at Penetrations	Included	Included	Included		Included	
Scaffolding for Own Work	90 Days	107,323	Included		Included	
Trade Damage - Plaster (40 Hours)	5,400	5,400	5,400	5,400	5,400	5,400
Drywall						
Drywall per Wall Types Sheet - A-620	203,565	233,312	196,876	278,790	233,555	233,555
This wall job is drywall over wood, no metal studs	Included	Included	Included	Included	Included	Included
Wall type A - 1 layer ea side	Included	Included	Included	Included	Included	Included
Wall type B - double stud walls 1 layer ea side	Included	Included	Included	Included	Included	Included
Wall type C - shear wall 1 layer ea side	Included	Included	Included	Included	Included	Included
Wall type D - 1-hr wall 1 layer ea side	Included	Included	Included	Included	Included	Included
Wall type E1 - 1-hr wall 1 layer ea side	Included	Included	Included	Included	Included	Included
Wall type F - 1 layer ea side	Included	Included	Included	Included	Included	Included
Wall type G - ext wall (plywood ea side by others) 1 layer on int, plaster over plywood ext	Included	Included	Included	Included	Included	Included
Wall type H - 2 layers ea side	Included	Included	Included	Included	Included	Included
Wall type I - 2 layers ea side (over plywood ea side by others)	Included	Included	Included	Included	Included	Included
Wall type K - acoustic wall double wood wall, 1 layer ea side, not on int side of double wall	Included	Included	Included	Included	Included	Included
Wall type N - int furred wall, 1 layer on one side	Included	Included	Included	Included	Included	Included

Bid Evaluation Report

Plaster & Drywall

Marshall Classroom Building

Description	Subcontractors				Perlite Plastering	Pacific Interiors
	Best Interiors	Standard Drywall	Church and Larsen	Premier Drywall		
	Job Number Bid Date	Date Printed	1641 6/7/2017	7/27/2017		
Wall type O - ext wall (plywood ea side by others) 1 layer on int, plaster over plywood ext	Included	Included	Included	Included		Included
Drywall Ceilings per Reflected Ceiling Plans A-121 to A-122	Included	Included	Included	Included		Included
See sections on sheets A-321-322 for ceiling info	Included	Included	Included	Included		Included
This ceiling job is drywall over wood, there a few areas there is metal framed ceilings?	Included	Included	Included	Included		Included
Finish Schedule A-612, ACT-1 in Classrooms as listed	Included	Included	Included	Included		Included
Impact resistant gypsum board below 10'-0" per Note 2 on Finish Legend A-612	5,000	5,000	Included	5,000		5,000
5/8" Drywall Horizontal & Vertical surfaces	Included	Included	Included	Included		Included
Cement Backerboard at Restroom Walls	Included	Included	Included	Included		Included
Level 1-5 Finish at Locations per Specifications Based on Paint or Wall Finish spec 09 2900.3.04.A	Level 4&2	Level 4	Level 4	Included		Included
Metal trims, joint treatments & finishing of walls ready for paint	Included	Included	Included	Included		Included
Texture & skim coats where indicated	Included	Included	Included	Included		Included
Clean-up	Included	Included	Included	Included		Included
Fire Resistant Sealants at Head and Base of Walls	Included	Included	Included	Included		Included
Acoustic Sealants as Shown and Spec'd	Included	Included	Included	Included		Included
Installation of HM Door Frames Supplied by Others	w/ DFH	w/ DFH	w/ DFH	w/ DFH		w/ DFH
Supply and Install of Access Panels 12x12	3,000	3,000	3,000	3,000		3,000
Installation of FEC Supplied by Others	1,350	1,350	1,350	1,350		1,350
Install drywall at elevator door frames after they are installed (by others)	1,500	1,500	1,500	1,500		1,500
Install ceiling at elevator room, not shown	1,000	1,000	1,000	1,000		1,000
Drywall Pickup	Included	Included	Included	Included		Included
Hoisting for Own Work	Included	Included	Included	Included		Included
Scraping and Disposal	6,375	6,375	6,375	6,375		6,375
Trade Damage - Drywall (80 Hours)	10,800	10,800	10,800	10,800		10,800
Fire Stops and Smoke Seals						
Mineral fiber insulation fire safing, damming material, clips and closures	7,551	7,551	7,551	7,551		7,551
Seal openings in floors, fire rated walls & penetrations	Included	Included	Included	Included		Included
At pipes, ducts, conduits & other items shown	Included	Included	Included	Included		Included
MFR - Bio Fireshield, 3M, GE or Nelson	Included	Included	Included	Included		Included
Sealants, firestop putty, mortar, pillows, mineral fiber safing	Included	Included	Included	Included		Included
ARC.1	9,250	9,250	9,025	9,250		9,250
ARC.17	(10,000)	(10,000)	(10,300)	(10,000)		(10,000)

Bid Evaluation Report

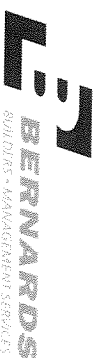

Plaster & Drywall		Marshall Classroom Building				Job Number	1641
		Subcontractors				Bid Date	6/7/2017
						Date Printed	7/27/2017
Description	Best Interiors	Standard Drywall	Church and Larsen	Premier Drywall	Perlite Plastering	Pacific Interiors	
ARC:20	(70,000)	(62,682)	(70,000)	(70,000)	(70,000)	(70,000)	
ARC:20	5,000	5,000	4,945	5,000	5,000	5,000	
TOTALS	697,601	827,146	538,346	659,716	621,081	653,005	
Recommendation:		Amount					
Church and Larsen		538,346					

Bid Evaluation Report



Title

Marshall Classroom Building

Job Number 1641

Bid Date 6/7/2017

Date Printed 7/27/2017

Description

Subcontractors

Stonerock Tile

J. Colavin & Son

Silverado Tile

Base Bid	99,325	110,210	91,500	0		
Spec #: 09 3013 - Ceramic Tiling	Included	Included	Included			
Furnished, Installed, FOB Jobsite, Tax Included	Included	Included	Included			
Plans and Specs Dated: 1/28/2016 & 10/4/2016	Included	Included	Included			
Acknowledgment of RFIs 1-75 dated 6.5.17	Included	Included	Included			
Bid Good for 60 Days	30 Days	90 Days	90 Days			
Prevailing Wage	Included	Included	Included			
Prequalified per Oxnard School District Standards	N/A	N/A	N/A			
Attachment C Acknowledgement	N/A	N/A	N/A			
Title	Included	Included	Included			
Finish Schedule A-612:	Included	Included	Included			
F3-Non-slip Ceramic Tile	Included	Included	Included			
B2-Coved Ceramic Tile Base	Included	Included	Included			
W1-Ceramic Tile Walls	Included	Included	Included			
MFR - Dal-Tile	Included	Included	Included			
DalTile Keystones 1"x1" Mosaic - Floors	Included	Included	Included			
DalTile Semi Gloss 6"x6" - Walls	Included	Included	Included			
Marble Thresholds	1,500	1,500	1,500			
Setting beds - Mortar and thinset	Included	Included	Included			
GROUT - Standard, Polymer modified, or Epoxy Grout - not spelled out in spec	Std grout	Std grout	Std grout			
Add for epoxy grout	Not provided	Not provided	Add: \$7,650			
Grout Sealer	4,085	Included	Included			
Waterproofing Membrane at depression - 283/A-510	Included	Included	Included			
Waterproofing type, 6 are listed in specs, 093013.9.2.1 2.6, which one do you have in your bid?	RedGuard	Included	RedGuard			
Wall Tile on 5/8" Cementitious Backer Board (by others) - 283/A-510	By Others	By Others	By Others			
Install per CTI Method W244, thinset method	Included	Included	Included			
Floor Tile on depressed concrete slab (by others) - 283/A-510	By Others	By Others	By Others			
Install per CTI Method F114, mudset/mortarset method	Included	Included	Included			
Locations:	Included	Included	Included			
Boys Toilet rm 110, 210	Included	Included	Included			
Boys Changing rm 111	Included	Included	Included			
Girls Toilet rms 113, 212	Included	Included	Included			
Girls Changing rm 114	Included	Included	Included			
Staff Toilet rms 112, 211	Included	Included	Included			

Bid Evaluation Report

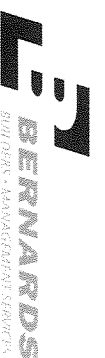

Title

Marshall Classroom Building

Job Number

1641

Bid Date

6/7/2017

Date Printed

7/27/2017

Description	Subcontractors			Amount
	Stonerock Tile	J. Colavin & Son	Silverado Tile	
Interior Elevations A-224	Included	Included	Included	
8' Ht Tile Mainscot (RFI # 24)	Included	Included	Included	
Safety walk and progressive cleanup	2,320	2,320	2,320	
Include Tile Behind Lockers, Provide Alternate Deduct to Remove	Included	Included	Included	
ARC:7	(21,500)	(21,500)	(21,670)	
ARC:16	(6,000)	(6,000)	(6,240)	
ARC:18	(16,000)	(16,000)	(16,290)	
TOTALS	63,730	70,530	51,120	0
Recommendation:	Amount			
Silverado Tile	51,120			0

Bid Evaluation Report

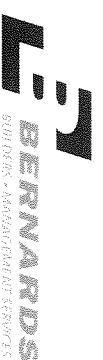

Acoustical Ceilings

Marshall Classroom Building

Description	Subcontractors				Job Number	Bid Date	Date Printed	Hamilton Ceiling Systems
	Alert Insulation	Standard Drywall	Commercial Interiors	CG Chaney				
Base Bid	41,500	53,030	42,490	35,775	1641	6/7/2017		
Spec #: 09 5123 - Acoustical Tile Ceilings	Included	Included	Included	Included	36,000	Included	Included	43,700
Spec #: 09 8434 - Acoustical Wall Panels (from RFI #7)					Included		Included	
Furnished, Installed, FOB Jobsite, Tax Included	Included	Included	Included	Included	Included		Included	Included
Plans and Specs Dated: 1/28/2016 & 10/4/2016	Included	Included	Included	Included	Included		Included	Included
Acknowledgment of RFI's 1-75 dated 6.5.17	Included	Included	Included	Included	Included		Included	Included
Bid Good for 60 Days	30 Days	30 Days	30 Days	Included	Included		Included	Included
Prevailing Wage	Included	Included	Included	Included	Included		Included	Included
Prequalified per Oxnard School District Standards	N/A	N/A	N/A	N/A	N/A		N/A	N/A
Attachment C Acknowledgement	N/A	N/A	N/A	N/A	N/A		N/A	N/A
Acoustical Panel Ceilings								
Reflected Ceiling Plans A-121 to A-122	Included	Included	Included	Included	Included		Included	Included
Finish Schedule A-612, ACT-1 in Classrooms as listed	Included	Included	Included	Included	Included		Included	Included
MFR - Armstrong, CertainTeed or USG	USG	Included	Included	USG	CertainTeed		CertainTeed	Included
Armstrong Fine Fissured, White, No Pattern, 3/4" Thick 24"x48"	Included	Included	Included	Included	Included		Included	Included
Grid - Prelude XL 15/16" Exposed Tee by Armstrong	DXL 26	Included	Included	Included	Included		Included	Included
ACT Details per A-540	Included	Included	Included	Included	Included		Included	Included
Include vertical struts, wall molding,space/stabilizer bars, hanger wire & attachment devices	Included	Included	Included	Included	Included		Included	Included
Include Compression struts per 2/A-540	Included	Included	Included	Included	Included		Included	Included
Read and abide by all Notes on sheet	Included	Included	Included	Included	Included		Included	Included
Safety walk and progressive cleanup	2,320	2,320	2,320	2,320	2,320		2,320	2,320
Include extra hanger wires for lighting fixtures, hvac registers & diffusers	600	600	600	600	600		Included	Included
ACT Panel w/ "L" moulding on face of soffit at ceiling ht change per 2/A-501	Included	Included	Included	Included	Included		Included	Included
Acoustical Wall Panels								
Spec provided in RFI#7 - Acoustical Wall Panels 09 8434	34,660	34,660	34,660	34,660	24,400		Included	34,660
AWP Type 1, Keynote 10.54					Included		Included	
MFR - Guilford FR-701 screen fabric, pattern 2100, 1" Thickness, 16.0+/ly weight					Included		Included	
Tackable Wall Panels					10,000		Included	
Finish Schedule A-612:					Included		Included	

Bid Evaluation Report



Acoustical Ceilings

Marshall Classroom Building

Description	Alert Insulation	Subcontractors			Prime Acoustics	Hamilton Ceiling Systems	
		Standard Drywall	Commercial Interiors	CG Chaney			
W5-Tackboard panel over gypsum board, Keynote 10.50					Included		
Color (not listed) provide per MFR standard color palette					Included		
Acoustical panels to be semi-rigid inorganic glass fiber material by Owens Corning, Johns Manville, Knauf or equal					Included		
Thickness of panels per Sound absorption coefficient requirement per tabulated values 09 8434,1.03,D					Included		
Provide cutouts in panels for plates, receptacles, outlets, switches, tstats, clocks, lights, etc.					Included		
Include all mounting hardware, concealed types, individually removable					Included		
See the Typical Room Layouts for Learning Labs, Science Classrooms & Performing Arts Lab - 1,2,3/A410					Included		
Interior elevations at classrooms A-220					Included		
Tackboard Floor to Ceiling see 3/A-530					Included		
Detail 3/A530 shows a 5/8" Corkboard cover with wall covering & alum edge piece 14 ga. Min entire perimeter					Included		
Installed directly over drywall walls					Included		
ARC:5					(24,400)		
TOTALS		79,080	90,610	80,070	73,355	48,320	80,680
Recommendation:		Amount					
Prime Acoustics		48,320					

Bid Evaluation Report

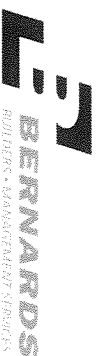

Acoustical Ceilings

Marshall Classroom Building

Subcontractors

Description	Ceiling Experts	Call-USA	Nelson Adams Naco	Tech-Wall	Job Number	1641
					Bid Date	6/7/2017
					Date Printed	7/27/2017
Base Bid	65,000	39,982	AWP Only	AWP Only		
Spec #: 09 5123 - Acoustical Tile Ceilings	N/A	Included	N/A	N/A		
	Included	Included	Included	Included		
Furnished, Installed, FOB Jobsite, Tax Included	Included	Included	Included	Included		
Plans and Specs Dated: 1/28/2016 & 10/4/2016	Included	Included	Included	Included		
Acknowledgment of RFI's 1-75 dated 6.5.17	Included	Included	Included	Included		
Bid Good for 60 Days	Included	30 Days	Included	Included		
Prevailing Wage	Included	Included	Included	Included		
Prequalified per Oxnard School District Standards	N/A	N/A	N/A	N/A		
Attachment C Acknowledgement	N/A	N/A	N/A	N/A		
Acoustical Panel Ceilings						
Reflected Ceiling Plans A-121 to A-122	Included	Included				
	Included	Included				
Finish Schedule A-612, ACT-1 in Classrooms as listed	Included	Included				
MFR - Armstrong, CertainTeed or USG	Armstrong	CertainTeed				
Armstrong Fine Fissured, White, No Pattern, 3/4" Thick 24"x48"	Included	Included				
	Included	Included				
Grid - Prelude XL 15/16" Exposed Tee by Armstrong	Included	Included				
	Included	Included				
ACT Details per A-540	Included	Included				
Include vertical struts, wall molding,space/stabilizer bars, hanger wire & attachment devices	Included	Included				
	Included	Included				
Include Compression struts per 2/A-540	Included	Included				
Read and abide by all Notes on sheet	Included	Included				
Include extra hanger wires for lighting fixtures, hvac registers & diffusers	600	600				
ACT Panel w/ "L" moulding on face of soffit at ceiling ht change per 2/A-501	Included	Included				
0						
Acoustical Wall Panels						
Spec provided in RFI#7 - Acoustical Wall Panels 09 8434	85,000	56,448	16,736	25,084		
	Included	Included	Included	Included		
AWP Type 1, Keynote 10.54	Included	Included	Included	Included		
MFR - Guilford FR-701 screen fabric, pattern 2100, 1" Thickness, 16.0+ /ly weight	Included	Included	9,000	Included		
Tackable Wall Panels	10,000	10,000	10,000	9,576		
Finish Schedule A-612:	Included	Included	Included	Included		

Bid Evaluation Report



Acoustical Ceilings

Marshall Classroom Building

Subcontractors

Description	Ceiling Experts	Call-USA	Subcontractors		Tech-Wall	Job Number	1641
			Nelson Adams Naco			Bid Date	6/7/2017
						Date Printed	7/27/2017
W5-Tackboard panel over gypsum board, Keynote 10.50	Included	Included	Included	Included	Included		
Color (not listed) provide per MFR standard color palette	Included	Included	Included	Included	Included		
Acoustical panels to be semi-rigid inorganic glass fiber material by Owens Corning, Johns Manville, Knauf or equal	Included	Included	Included	Included	Included		
Thickness of panels per Sound absorption coefficient requirement per tabulated values 09 8434,1.03,D	Included	Included	Included	Included	Included		
Provide cutouts in panels for plates, receptacles, outlets, switches, tstats, clocks, lights, etc.	Included	Included	Included	Included	Included		
Include all mounting hardware, concealed types, individually removable	Included	Included	Included	Included	Included		
See the Typical Room Layouts for Learning Labs, Science Classrooms & Performing Arts Lab - 1,2,3/A410	Included	Included	Included	Included	Included		
Interior elevations at classrooms A-220	Included	Included	Included	Included	Included		
Tackboard Floor to Ceiling see 3/A-530	Included	Included	Included	Included	Included		
Detail 3/A530 shows a 5/8" Corkboard cover with wall covering & alum edge piece 14 ga. Min entire perimeter	Included	Included	Included	Included	Included		
Installed directly over drywall walls	Included	Included	Included	Included	Included		
ARC.5							
TOTALS	160,600	107,030	35,736	34,660	0	0	0
			AWP Only	AWP Only			
Recommendation:	Amount						
Prime Acoustics	48,320						

Bid Evaluation Report

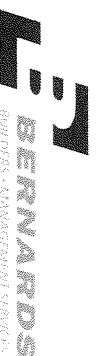

Carpet & Resilient Flooring

Marshall Classroom Building

Subcontractors

Job Number **1641**
 Bid Date **6/7/2017**
 Date Printed **7/27/2017**

Description	Subcontractors				Job Number	Bid Date	Date Printed
	Reliable Flooring	JJJ Flooring	Floor Tech America	Continental Flooring			
Base Bid	59,951	64,560	76,887	65,126			
Spec #: 09 6513 - Rubber Base	Included	Included	Included	Included			
Spec #: 09 6519 - Resilient Tile Flooring	Included	Included	Included	Included			
Furnished, Installed, FOB Jobsite, Tax Included	Included	Included	Included	Included			
Plans and Specs Dated: 1/28/2016 & 10/4/2016	Included	Included	Included	Included			
Acknowledgment of RFIs 1-75 dated 6.5.17	Included	Included	Included	Included			
Bid Good for 60 Days	30 Days	Included	Included	Included			
Prevailing Wage	Included	Included	Included	Included			
Prequalified per Oxnard School District Standards	N/A	N/A	N/A	N/A			
Attachment C Acknowledgement	N/A	N/A	N/A	N/A			
Flooring							
Minor Floor Prep	Included	Included	Included	Included			
Testing for PH and Moisture	Included	Included	Included	Included			
Remediation if Applicable	Included	Included	Included	Included			
Resilient Flooring and Rubber Base							
Finish Schedule A-612, F2-Linoleum Tile, B1-4" Vinyl Resilient Base	Included	Included	Included	Included			
MFR - Forbo, Marmoleum Composition Tile (MCT) 13"x13", 2mm thk, pattern & color by Architect	Included	Included	Included	Included			
Include all adhesives & sealants	Included	Included	Included	Included			
Heat-welding of seams with color-matched color rods	6,700	6,700	6,700	6,700			
Resilient Base - Rubber, Cove, 4", preformed inside & outside corners	Included	Included	Included	Included			
MRF - Burke/Mercer, Roppe/Pinnacle, Flexco or equal	Included	Included	Included	Included			
F2 at All Classrooms	Included	Included	Included	Included			
B1 at All Classrooms, storage, back of house rooms	Included	Included	Included	Included			
F2 MCT in Elevator Cab (not listed but include)	640	640	640	640			
Include cleaning of floors after installation per specs	Included	Included	Included	Included			
Safety walk and progressive cleanup	2,320	2,320	2,320	2,320			
Include initial maintenance "starter kit" from manufacturer and conducted (1st time) by flooring sub spec 3.08.B	Included	Included	Included	Included			
Include protection of floors after installation per specs	Included	Included	Included	Included			
TOTALS	69,611	74,220	86,547	74,786	0	0	
Recommendation:	Amount						
Reliable Flooring	69,611						

Bid Evaluation Report

Painting

Marshall Classroom Building

Description	Subcontractors				Job Number	Date Printed	Valley Painting
	Vanguard	Borbon Inc	Triumph Painting	Prime Painting			
Base Bid	53,100	102,000	155,800	185,000	0	0	
Spec #: 07 9200 - Joint Sealants	Included	Included	Included	Included			
Spec #: 09 9000 - Paints and Coatings	Included	Included	Included	Included			
Furnished, Installed, FOB Jobsite, Tax Included	Included	Included	Included	Included			
Plans and Specs Dated: 1/28/2016 & 10/4/2016	Included	Included	Included	Included			
Acknowledgment of RFI's 1-75 dated 6.5.17	Included	Included	Included	Included			
Bid Good for 60 Days	Included	Included	90 Days	Included			
Prevailing Wage	Included	Included	Included	Included			
Prequalified per Oxnard School District Standards	N/A	N/A	N/A	N/A			
Attachment C Acknowledgement	N/A	N/A	N/A	N/A			
Painting and Coating							
BOD - Dunn Edwards or Equal	Included	Included	Included	Included			
Colors TBD	Included	Included	Included	Included			
Finish Schedule A-612:	Included	Included	Included	Included			
F1-Sealed Concrete	w/ waterproofing	w/ waterproofing	w/ waterproofing	w/ waterproofing			
P1-Interior Semi-Gloss Paint	Included	Included	Included	Included			
P2-Interior Gloss Paint	Included	Included	Included	Included			
P3-Clear Sealant	Included	Included	Included	Included			
(3) Top Coats and (1) Coat Primer	Included	Included	Included	Included			
Exterior Plaster Walls & Soffits - 4 coats	Included	Included	Included	Included			
Interior Walls, Soffits and Ceilings, 4 coats	Included	Included	Included	Included			
Exterior & Interior HM Door Frames, 3 coats	Included	Included	Included	Included			
Exterior & Interior HM Doors, 3 coats	Included	Included	Included	Included			
Exterior & Interior Wood Doors, 4 coats	Included	Included	Included	Included			
All Exposed Steel to be Primed with Zinc Coating to Receive Paint (RFI #38)	Included	Included	Included	Included			
Paint Steel Stair Pans, Columns, Stringers, Guardrails and Handrails (RFI #38)	Included	Included	Included	Included			
All Exposed Metal on Roof to be Galvanized per Spec, No Paint Finish (RFI #47)	Included	Included	Included	Included			
Etching galvanized guardrails, handrails & stairs prior to painting	Included	Included	Included	Included			
Insulated and Exposed Pipes, Ducts, Conduit, Hangers, Brackets, Collars and Supports, Mechanical and Electrical Equipment	Included	Included	Included	Included			
Shop-Primed Items	Included	Included	Included	Included			
High Performance Coating at Ext. Hand and Guardrails	Not Included	Not Included	Not Included	Not Included			
Exterior Stairs Shop Primed and Painted	Included	Included	Included	Included			
HSS Steel at Ext. exposed Columns & Beams	Included	Included	Included	Included			
Cleanup of all your work	Included	Included	Included	Included			
Touch-Up Painting Allowance	5,092	5,092	5,092	5,092			

Bid Evaluation Report

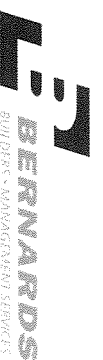

Painting

Marshall Classroom Building

Subcontractors

Description	Subcontractors				Job Number	1641
	Vanguard	Borbon Inc	Triumph Painting	Prime Painting	Date Printed	6/7/2017
				Prime Painting	Valley Painting	7/27/2017
Joint Sealant Work Allowance	2,500	2,500	2,500	2,500		
Hedge	26,800					
ARC:1	2,000	2,000	2,000	2,000		
ARC:4	10,700	11,000	11,000	11,000		
ARC:5	3,000	3,000	3,000	3,000		
ARC:17	(1,000)	(1,000)	(1,000)	(1,000)		
TOTALS	102,192	124,592	178,392	207,592	0	0
Recommendation:	Amount					
Vanguard	102,192					

Bid Evaluation Report

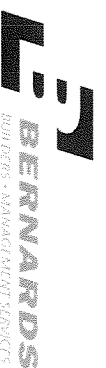

Building Specialties

Marshall Classroom Building

Job Number 1641
 Bid Date 6/7/2017
 Date Printed 7/27/2017

Div	Description	Amount	Recommended Subcontractor	Bids Received
-----	-------------	--------	---------------------------	---------------

10 44 00	Fire Extinguishers & Specialties	3,045	BL Wilcox (\$3,045 Supplier)	3
-----------------	---	-------	------------------------------	---

	See sheet A-111 & A-112 for locations of FEC	Included	Inland Empire (\$5,300)	
--	--	----------	-------------------------	--

	1st fl Keynote 10.51 - Fire Extinguisher Cabinet	Included	John Pence (\$4,800)	
--	--	----------	----------------------	--

	Semi-Recessed, see 6&7/A-530			
--	------------------------------	--	--	--

	2nd fl Keynote 10.55 - Fire Extinguisher Cabinet	Included		
--	--	----------	--	--

	Semi-Recessed, see 6&7/A-530			
--	------------------------------	--	--	--

	1st Fl (8 ea)	Included		
--	---------------	----------	--	--

	2nd Fl (1 ea)	Included		
--	---------------	----------	--	--

	Provide rated cabinet at rated wall per note on 7/A-530	Included		
--	---	----------	--	--

	Semi Recessed FEC Max. Projection 4" (RFI #32)			
--	--	--	--	--

10 50 50	Lockers	46,600	Inland Empire	1
-----------------	----------------	--------	---------------	---

	Added Spec Section in RFI #9 - Section 10505 dated 5/23/2017	Included		
--	--	----------	--	--

	See Accessible Locker Calculations on sheet A-411, total of 8	Included		
--	---	----------	--	--

	MFR - DeBourgh Manufacturing Co. or equal	Included		
--	---	----------	--	--

	Interior Elevations A-224, see Keynotes	Included		
--	---	----------	--	--

	12.10 - 12"x12" triple stack locker, see 13/A-530	Included		
--	---	----------	--	--

	12.13 - Accessible locker, see 13/A-530	Included		
--	---	----------	--	--

	12.31 - 20"x48" Accessible Locker room bench (handwritten on bottom of keynotes legend)	Included		
--	---	----------	--	--

	1-Tier Lockers per detail 13/A-530 - None shown	Included		
--	---	----------	--	--

	2-Tier Lockers per detail 13/A-530 - None shown	Included		
--	---	----------	--	--

	3-Tier Lockers per 13/A-530	Included		
--	-----------------------------	----------	--	--

	At Boys Changing Room - 1/A-411, total of 32, 3-tier	Included		
--	--	----------	--	--

	Accessible at Boys Changing Room - 1/A-411, total of 1 ea	Included		
--	---	----------	--	--

	At Girls Changing Room - 1/A-411, total of 32, 3-tier	Included		
--	---	----------	--	--

	Accessible at Girls Changing Room - 1/A-411, total of 1 ea	Included		
--	--	----------	--	--

	Include Locker base at stud wall installation per 15/A-530	Included		
--	--	----------	--	--

	Coordinate blocking & backing w/ Framer	Included		
--	---	----------	--	--

	At concrete slab use anchor bolts per detail 3/8" dia 3" embedment	Included		
--	--	----------	--	--

	6" Upturned C/P concrete base w/ tooled radius at lockers - 14 & 15/A-530	w/ Concrete		
--	---	-------------	--	--

Bid Evaluation Report



Building Specialties

Marshall Classroom Building

Job Number	1641
Bid Date	6/7/2017
Date Printed	7/27/2017

Div	Description	Amount	Recommended Subcontractor	Bids Received	
N/A	Misc Site Furnishings	0	Bernards		
	None Noted				
N/A	Misc Equipment (TV's)	6,000	Bernards		
	TV Wall Brackets - 1/A-531	Included			
	MFR not listed, size is 2'-5"X2'	Included			
	Furnished	by District			
	Installed	Included			
	Coordinate blocking & backing w/ framing sub	Included			
	TV's in Classrooms	by District			
	60" Flat Screen by District	by District			
	Final hook-up, connection to Teachers computer	by District			
	Total	55,645			

Bid Evaluation Report



Visual Display Boards

Marshall Classroom Building

Subcontractors

Job Number 1641

Bid Date 6/7/2017

Date Printed 7/27/2017

Description	ABC School Equipment		Nelson Adams Naco Inc.		0	0	0	0
	ABC School Equipment	Nelson Adams Naco Inc.	ABC School Equipment	Nelson Adams Naco Inc.				
Base Bid	275,308	208,582						
Spec #: 101101	Included	Included						
Spec #:								
Furnished, Installed, FOB Jobsite, Tax Included	Included	Included						
Plans and Specs Dated: 1/28/2016 & 10/4/2016	Included	Included						
Acknowledgment of RFT's 1-75 dated 6.5.17	Included	Included						
Bid Good for 60 Days	60 Days	Included						
Prevailing Wage	Included	Included						
Pregualified per Oxnard School District Standards	N/A	N/A						
Attachment C Acknowledgement	N/A	N/A						
Visual Display Boards								
Finish Schedule A-612:	Included	Included						
W4 - Marker Board Panel over gypsum board	Included	Included						
Interior Elevations sheets A-220 to A-223	Included	Included						
Keynote 10.52-Markerboard Surface from floor to ceiling, Standard panel size 5'x10'	Included	Included						
Keynote 12.26 - 3'-2"x10' Sliding Marker Board, see 10/A-530	Included	Included						
Keynote 12.27 - (2) 2'-8"x10' Sliding Marker Boards, see 10/A-530	Included	Included						
MFR - MooreCo, Claridge or Polyvision or Equal	Platinum Visual	Nelson Adams Naco						
There is a Marker Board Sliding Door Schedule listing all the rooms to receive them on A-610	Included	Included						
Horizontal Sliding Unit Wall System Assembly per 10/A-530	Included	Included						
Furnished AND Installed	Included	Included						
First Floor Classrooms - total of 19 each	Included	Included						
Second Floor Classrooms - total of 23 each	Included	Included						
ARC.4	(60,500)	(60,223)						
TOTALS	214,808	148,359	0	0	0	0	0	0
Recommendation:	Amount	148,359						
Nelson Adams Naco Inc.	148,359							

Bid Evaluation Report



Signage

Marshall Classroom Building

Subcontractors

Job Number **1641**
 Bid Date **6/7/2017**
 Date Printed **7/27/2017**

Description	AGS	Subcontractors			Braille Signs, INC	Job Number	Bid Date	Date Printed
		John Pence Bldg Spec.	CA Signs					
Base Bid	6,150	10,130	11,471	15,302				
Spec #: 10 1400 - Signage	Included	Included	Included	Included				0
Spec #:								0
Furnished, Installed, FOB Jobsite, Tax Included	Included	Included	Included	Included				
Plans and Specs Dated: 1/28/2016 & 10/4/2016	Included	Included	Included	Included				
Acknowledgment of RFIs 1-75 dated 6.5.17	Included	Included	Included	Included				
Bid Good for 60 Days	Included	Included	Included	Included				
Prevailing Wage	Included	Included	Included	Included				
Prequalified per Oxnard School District Standards	N/A	N/A	N/A	N/A				
Attachment C Acknowledgement	N/A	N/A	N/A	N/A				
Signage	Included	Included	Included	Included				
Signage at Each Bldg per Floor Plans and Elevations	Included	Included	Included	Included				
Signage & Fire Extinguisher Plans - G-006	Included	Included	Included	Included				
Signage Details sheet - A-550	Included	Included	Included	Included				
Room Signs - 1/A-550	Included	Included	Included	Included				
Toilet room door signage - 3/A-550	Included	Included	Included	Included				
Fire Riser door signage - 5/A-550	200	Included	Included	Included				
Exit Signs - 6,7,8/A-550	Included	Included	Included	Included				
Typical Classroom I.S.A signage - 9/A-550	Included	Included	Included	Included				
Restroom Signs - Girls, Boys, Unisex, Staff - Wall & Door signage 3,11,13,14/A-550	Included	Included	Included	Included				
Fire Alarm Panel Control - 12/A550	Included	Included	Included	Included				
Electrical & Not an exit signage 15/A-550	Included	Included	Included	Included				
Maximum occupancy signage - 16/A550	Included	Included	Included	Included				
Stenciling on Rated Walls Signage - 19/A-550	w/ Drywall	w/ Drywall	w/ Drywall	w/ Drywall				
Warning sign - 20/A-550	300	Included	Included	Included				
Fire Extinguisher Signage - 6/A-530, G-006 (17 ea)	2,975	Included	Included	Included				
Assistive Listening Signage	250	Included	Included	Included				
ADA Signage	Included	Included	Included	Included				
Ext. Aluminum Letters, or Painted Bldg # (No Callouts on Elevations)	750	750	750	750				
See Spec Section for several other signs as required	Included	Included	Included	Included				
Site Signage at Fire Lane shown on Site Plan A-101	w/ Striping	w/ Striping	w/ Striping	w/ Striping				
Site Signage at Re-Striped existing parking lot shown on A-102, 104, 105	w/ Striping	w/ Striping	w/ Striping	w/ Striping				
Temporary project signage	2,000	2,000	2,000	2,000				
TOTALS	12,625	12,880	17,196	18,302				0
Recommendation:	Amount							0
AGS	12,625							

Bid Evaluation Report



Toilet Compartments & Accessories

Marshall Classroom Building

Subcontractors

Description	Subcontractors				Job Number	Date Printed
	Inland Empire Arch	YTI Enterprises	John Pence Bldg Spec.	Stumbaugh		
Base Bid	31,400	23,200	30,700	34,192	1641	6/17/2017
Spec #: 10 2113.17 - Phenolic-Core Shower & Dressing Compartments	Included	Included	Included	Included		7/27/2017
Spec #: 10 2800 - Toilet Accessories	Included	Included	Included	Included		
Furnished, Installed, FOB Jobsite, Tax Included	Included	Included	Included	Included		
Plans and Specs Dated: 1/28/2016 & 10/4/2016	Included	Included	Included	Included		
Acknowledgment of RFIs 1-75 dated 6.5.17	Included	Included	Included	Included		
Bid Good for 60 Days	30 Days	Included	Included	Included		
Prevailing Wage	Included	Included	Included	Included		
Prequalified per Oxnard School District Standards	N/A	N/A	N/A	N/A		
Attachment C Acknowledgement	N/A	N/A	N/A	N/A		
Toilet Compartments	Included	Included	Included	Included		
Solid Phenolic MFR by Formica, Trespa, Pionite ore equal	Accutec	Included	Included	Included		
Galaxy hardware, Series 8033	Included	Included	Included	Included		
Fire Rated Class B for ASTM E84	Included	Included	Included	Included		
Overhead braced	Included	Included	Included	Included		
Accessible compartments	Included	Included	Included	Included		
Standard compartments	Included	Included	Included	Included		
Urinal Screens	Included	Included	Included	Included		
Vestibule Screens	Included	Included	Included	Included		
No colors selected, include standard color palette in your bid	Formica Sparkle	Formica or Wilsonart	Black	Standard Color		
Toilet Accessories	Included	Included	Included	Included		
MFR - Bobrick or approved equal	Included	Included	Included	Included		
Interior Elevations A-224, see Keynotes	Included	Included	Included	Included		
10.03 - Tactile room name & number signage 1/A-550	w/ Signage	w/ Signage	w/ Signage	w/ Signage		
10.03 - Toilet room door signage 3/A-550	w/ Signage	w/ Signage	w/ Signage	w/ Signage		
10.32 - Paper towel dispenser & Waste receptacle 1/A-535	Included	Included	Included	Included		
10.33 - Surface mounted soap dispenser 1/A-5353, B-211	Included	Included	Included	Included		
10.34 - Multi-roll toilet tissue dispenser, semi recessed 1/A-5353, B-3888	Included	Included	Included	Included		
10.36 - Grab bar - 1, 8 & 10/A-5353, B-6806 series, length per drawing	Included	Included	Included	Included		
10.37 - Seat cover dispenser 1/A-5353, B-221	Included	Included	Included	Included		
10.39 - Mirror 18"x30" 1/A-5353, B-292	Included	Included	Included	Included		
10.41 - Accessible side toilet stall 11/A-5353	Included	Included	Included	Included		
Janitor Closet Accessories	Included	Included	Included	Included		

Bid Evaluation Report

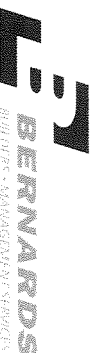

Toilet Compartments & Accessories

Marshall Classroom Building

Subcontractors

Job Number 1641
 Bid Date 6/7/2017
 Date Printed 7/27/2017

Description	Subcontractors				Amount
	Inland Empire Arch	YTI Enterprises	John Pence Bldg Spec.	Stumbaugh	
Mop & Broom Holder (4 Holders) B-223 x 36"	Included	Included	Included	Included	
Not Keynoted, but listed in Spec Section:					
Hand Dryer, World Dryer Model XRA	4,200	4,200	4,200	Included	
Sanitary Napkin Disposal, Recessed B-353 or Partition Mounted B-354	Included	4,800	Included	Included	
Sanitary Napkin Dispenser, Recessed B-3706 25	1,000	1,000	1,000	1,000	
Keys at locked dispensing units, keyed alike	Included	Included	Included	Included	
Other Potential Items:					
Backpack Hooks in Rooms	Excluded	Excluded	Excluded	Excluded	
ARC.14	(4,200)	(4,200)	(4,200)	(4,200)	
TOTALS	32,400	29,000	31,700	30,992	0
Recommendation:					
YTI Enterprises	Amount 29,000				

Bid Evaluation Report



Window Coverings

Marshall Classroom Building

Subcontractors

Description	Subcontractors				Diversified Window	Shevard & Son & Sons	Job Number	1641
	A1 Quality Blinds	Digital Decora	Contract Décor				Date Printed	6/7/2017
Base Bid	10,000	15,440	16,340	21,248		27,860		
Spec #: 12 2413 - Roller Window Shades								
Furnished, Installed, FOB Jobsite, Tax Included	Included	Included	Included	Included	Included	Included		
Plans and Specs Dated: 1/28/2016 & 10/4/2016	Included	Included	Included	Included	Included	Included		
Acknowledgment of RFIs 1-75 dated 6.5.17	Included	Included	Included	Included	Included	Included		
Bid Good for 60 Days	90 Days	Included	90 Days	90 Days	90 Days	90 Days		
Prevailing Wage	Included	Included	Included	Included	Included	Included		
Pregualified per Oxnard School District Standards	N/A	N/A	N/A	N/A	N/A	N/A		
Attachment C Acknowledgement	N/A	N/A	N/A	N/A	N/A	N/A		
Window Coverings	Included	Included	Included	Included	Included	Included		
MFR - Levelor, HD, Spring	Included	Included	Included	Included	Included	Included		
New Classroom Building	Included	Included	Included	Included	Included	Included		
All Windows Interior and Exterior	Included	Included	Included	Included	Included	Included		
Motor Operated (Where Shown)	Excluded	Excluded	Excluded	Excluded	Excluded	Excluded		
MFR - ElectroShade by Mechoshade Systems or approved equal	Excluded	Excluded	Excluded	Excluded	Excluded	Excluded		
Manual Operated at all windows	Included	Included	Included	Included	Included	Included		
MFR - Mechno/5 by Mechoshade Systems or approved equal	Hunter Douglass	Lutron Contract	FlexShades	Included	Included	Included		
Provide a complete operated system including fabric, mounting spline, end caps, fascia, filters, side channels, center channels, anchors and fasteners	Included	Included	Included	Included	Included	Included		
Fabric "AV Blackout shade my Mechoshade or equal	Included	Included	Included	Included	Included	Included		
TOTALS	10,000	15,440	16,340	21,248		27,860	0	
Recommendation:	Amount							
A1 Quality Blinds	10,000							
Alternates								
RFI #25								
Alt #1: Manual Roller Shades at Larger Sectional Doors at Classrooms	9,000	12,628	20,820	Excluded		20,820		
Alt #2: ADD for Motorized Roller Shades at Larger Sectional Doors at Classrooms	13,500	37,552	41,930	Excluded		41,930		

Bid Evaluation Report

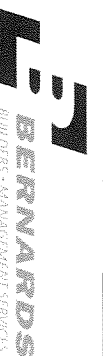

Final Cleaning

Marshall Classroom Building

Subcontractors

Description	AAA Express Janitorial	All-Pro Bidg Maintenance	Commercial Const Cleaning	Job Number	1641
				Bid Date	6/7/2017
				Date Printed	7/27/2017
Base Bid	2,700	28,760	22,550		
Spec #: N/A	N/A	N/A	N/A		
Furnished, Installed, FOB jobsite, Tax Included	Included	Included	Included		
Plans and Specs Dated: 1/28/2016 & 10/4/2016	Included	Included	Included		
Acknowledgment of RFIs 1-75 dated 6.5.17	Included	Included	Included		
Bid Good for 60 Days	Included	Included	Included		
Prevailing Wage	Included	Included	Included		
Prequalified per Oxnard School District Standards	Included	N/A	N/A		
Attachment C Acknowledgement	Included	N/A	N/A		
Final Construction Cleaning					
Provide all safety equipment, hard hats, gloves, eye protection & vest	Included	Included	Included		
Include all cleaning tools, ladders, mops, brooms, towels, etc.	Included	Included	Included		
Clean elevator, inside & out	500	Included	Included		
Clean interior windows & mullions	Included	Included	Included		
Clean exterior windows	3,500	Included	Included		
Clean all cabinets, counter & millwork	Included	Included	Included		
Clean inside cabinets & drawers, shelves, bookcases	1,500	Included	Included		
Clean all door frames, hardware & kick-plates	Included	Included	Included		
Wipe clean baseboards	Included	Included	Included		
Wipe clean lights & T-bar ceiling (as required)	Included	Included	Included		
Vacuum all carpeted areas	Included	Included	Included		
Clean all air return grills	Included	Included	Included		
Clean all items attached to walls-FEC, MEP devices, signage marker bds, etc.	1,500	Included	Included		
Wipe, clean mech & elec rms equip, ductwork, conduit & piping	1,500	Included	Included		
Clean Boy's & Girl's restrooms & locker rooms	Included	Included	Included		
Clean plumbing fixtures, toilet part, sinks, mirrors, tops, toilets, lockers, etc.	2,500	Included	Included		
Clean tile floors & walls	2,500	Included	Included		
Sweep & mop all floors	Included	Included	Included		
Wax, 3-coat, all VCT floors	2,500	Included	Included		
Sweep & mop all exterior walkways, corridors, stairways & gurradrails	2,500	Included	Included		
Sweep & power wash ext bldg walks, sidewalk & hardscape	3,500	Included	3,500		

Bid Evaluation Report

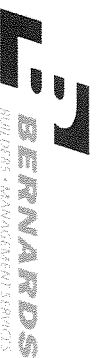

Final Cleaning

Marshall Classroom Building

Subcontractors

Description	AAA Express Janitorial	All-Pro Bldg Maintenance	Commercial Const. Cleaning	Job Number	1641
					Bid Date
				Date Printed	7/27/2017
Prevailing Wage rates requirements	5,000	Included	Included		
T&M rate per employee			\$79.80/hr		
TOTALS	29,700	28,760	26,050	0	0
Recommendation:		Amount			
Commercial Const Cleaning		26,050			

Bid Evaluation Report



Elevators

Marshall Classroom Building

Subcontractors

Job Number **1641**
 Bid Date **6/7/2017**
 Date Printed **7/27/2017**

Description	Kone, Inc.	Republic Elevator				
			Amount			
Base Bid	195,850	ALT: \$89,860				
Spec #: 14 2123 - Machine-Room-Less Electric Traction Passenger Elevators	Included	No Use Hydro				
Bond Rate	Bond at	Bond at				
Furnished, Installed, FOB Jobsite, Tax Included	Included	Included				
Plans and Specs Dated: 1/28/2016 & 10/4/2016	Included	Included				
Acknowledgment of RFIs 1-75 dated 6.5.17	Included	Included				
Bid Good for 60 Days	30 Days	60 days				
Prevailing Wage	Included	Included				
Prequalified per Oxnard School District Standards	N/A	N/A				
Attachment C Acknowledgement	N/A	N/A				
Elevators						
Deferred Approval - Elevator Guide Rails, G-001	Included	Included				
MFR, BOD - Kone EcoSpace Gearless Traction Elevator	Included	Twin Jack, Holeless				
Hoist Beam, Guide Rails per specs	w/ Steel	w/ Steel				
Pit ladder 13/A-561, notes states by Elev Mfr	w/ Steel	w/ Steel				
Continuous plate PL 3/16"x3" cont across hoistway 5&7/A-561	w/ Steel	w/ Steel				
Bldg I - New Classroom Building	Included	Included				
Elevator No. 1: 3500#, 150ft/min, 2 Stops, 2 Openings per Specs	Included	Included				
Includes all info for Elevator Details shown on sheet A-561	Included	Included				
Cab Interior Finishes - brushed SS at walls, front & doors w/ alum tube rail, ceiling translucent panels, alum threshold, floor (by others)	Included	Included				
Metalworks Linear Faceted/Curved Ceiling system 8" panel per Note 9.03/G-006, see det 4/A-541 (no sheet A-541 provided)	Exclude/Qualify	Exclude/Qualify				
Make Connection Between Fire Alarm Relay and Elevator Controller	Included	Included				
Elevator Hostway Scaffolding	Included	Included				
Hoisting	Included	Included				
Textura invoice system	360	360				
ARC.10	(196,210)	89,860				
TOTALS	0	90,220	0	0	0	0
Recommendation:	Amount					
Republic Elevator	90,220					

Bid Evaluation Report

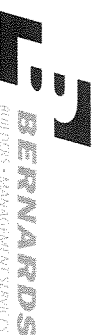

Fire Sprinklers

Marshall Classroom Building

Job Number 1641
 Bid Date 6/7/2017
 Date Printed 7/27/2017

Subcontractors

Description	Subcontractors		
	Apex Fire Protection	J.G. Tate Fire Protection	Superior Fire
Base Bid	276,600	123,456	126,266
Spec # : 21 1000 - Fire Protection	Included	Included	Included
License Designation C-16, Fire Protection Contractor	Included	Included	Included
Furnished, Installed, FOB Jobsite, Tax Included	Included	Included	Included
Plans and Specs Dated: 1/28/2016 & 10/4/2016	Included	Included	Included
Acknowledgment of RFIs 1-75 dated 6.5.17	Included	Included	Included
Bid Good for 60 Days	60 Days	30 Days	30 days
Prevailing Wage	Included	Included	Included
Prequalified per Oxnard School District Standards	No	Yes	Yes
Attachment C Acknowledgement	Included	Included	Included
Furnish & Install Fire Sprinkler System	Included	Included	Included
Building 1, Classroom Building per FP sheets - FP-001 to 005	Included	Included	Included
<i>Manufacturer - Tyco</i>	Included	Included	Included
Complete Wet Pipe Automatic Sprinkler System	Included	Included	Included
UL Approved Black Steel Piping, SCH 40 w/ Cast or Ductile Iron Screwed Fittings - 2" and Smaller	Included	Included	Included
UL Approved Black Steel Piping, SCH 40 w/ Rolled Grooved Ends, Grooved Fittings and Mechanical or Welded Outlets - 2.5" and Larger	Included	Included	Included
Complies with NFPA 13, 2013 ED., DSA, and Local AHJ Requirements	Included	Included	Included
POC from 6" AFF, 4x3 Flexible GRC	Included	Included	Included
3" Fire Riser at Bldg - 1/FP-002	Included	Included	Included
Connect 6" Underground Fire Department Connection	w/ Site Utilities	w/ Site Utilities	w/ Site Utilities
4" Double Detector Check Valve Backflow Preventer (1/FP-02)	w/ Site Utilities	w/ Site Utilities	w/ Site Utilities
Standard Upright, Pendant, Sidewall Sprinklers	Included	Included	Included
Concealed Heads in Finished Ceilings w/ Cover Plate	Included	Included	Included
Flush Sidewall Head in Soffits	Included	Included	Included
Brass or White Finish	Included	Included	Included
All Underground Piping as Required	w/ Site Utilities	w/ Site Utilities	w/ Site Utilities
Piping Distribution (Risers, Mains & Branch Lines)	Included	Included	Included
Upright Sprinkler Deflectors as Shown	Included	Included	Included
Provide Head Guards as Required	Included	Included	Included
Head Box w/ Spare Heads and Wrenches	Included	Included	Included
Install Ceiling Tiles w/ Sprinkler Heads in Panels Where Required (FP-03)	Included	Included	Included

Bid Evaluation Report



Fire Sprinklers

Marshall Classroom Building

Subcontractors

Job Number **1641**
 Bid Date **6/7/2017**
 Date Printed **7/27/2017**

Description	Subcontractors			TOTALS	RECOMMENDATION
	Apex Fire Protection	J.G. Tate Fire Protection	Superior Fire		
Install sprinklers in elevator shaft and elevator equipment, not shown	2,500	2,500	2,500		
All Seismic Bracing, Hangers, Embeds as Required	Included	Included	Included		
Sleeves as Required	Included	Included	Included		
Floor Blockouts, Coring, Saw Cutting as Required	Included	Included	Included		
All Gauges, Valves, Flow and Tamper Switches	Included	Included	Included		
Valve Seals, Tags, Safety Markers, and Charts	Included	Included	Included		
Electric Bell	Included	Included	Included		
Sound and Vibration Control	Included	10,000	Included		
Furnish Access Panels as Required	Included	Included	1,250		
Excavation and Backfill as Required	w/ Site Utilities	w/ Site Utilities	w/ Site Utilities		
Fire Caulking / Sleeves / Firestopping	Included	Included	1,250		
Permits / Plan Check / Inspections / Testing / Fees	1,000	1,000	1,000		
Hydrostatic Testing at 200 PSI for (2) Hours	Included	Included	Included		
Calculations / Engineered Plans / Shop Drawings	Included	Included	2,500		
BIM Coordination	5,000	5,000	5,000		
As-Builts and Record Documents	Included	Included	Included		
Hoisting of Own Material as Required	Included	Included	Included		
Schedule and Pay for State and Local Inspections	1,500	1,500	1,500		
TOTALS	286,600	143,456	151,266	0	0
Recommendation:	Amount				
J.G. Tate Fire Protection	143,456				

Bid Evaluation Report



Plumbing

Marshall Classroom Building

Subcontractors

Description	City Commercial	HPS Mechanical	Moe	Precision Plumbing-Mechanical	Job Number		
					Suttles Plumbing	1641	
						Bid Date	6/7/2017
						Date Printed	7/27/2017
Base Bid	315,100	349,530	335,765	416,610	412,000		
Spec #: 22 0500 - Basic Materials and Methods	Included	Included	Included	Included	Included		
Spec #: 22 0553 - Identification	Included	Included	Included	Included	Included		
Spec #: 22 0700 - Insulation	Included	Included	Included	Included	Included		
Spec #: 22 0800 - Equipment and Systems Tests	Included	Included	Included	Included	Included		
Spec #: 22 1100 - Domestic and Industrial Water Systems	Included	Included	Included	Included	Included		
Spec #: 22 1300 - Drainage System	Included	Included	Included	Included	Included		
Spec #: 22 4000 - Plumbing Fixtures	Included	Included	Included	Included	Included		
Furnished, Installed, FOB Jobsite, Tax Included	Included	Included	Included	Included	Included		
Plans and Specs Dated: 1/28/2016 & 10/4/2016	Included	Included	Included	Included	Included		
Acknowledgment of RFI's 1-75 dated 6.5.17	Included	Included	Included	Included	Included		
Bid Good for 60 Days	30 Days	30 Days	60 Days	60 Days	90 Days		
Prevailing Wage	Included	Included	Included	Included	Included		
Prequalified per Oxnard School District Standards	Yes	Yes	No	Yes	Yes		
Attachment C Acknowledgement	Included	Included	Included	Included	Included		
Furnish & Install All Plumbing Fixtures w/ Associated Connections	Included	Included	Included	Included	Included		
Plumbing Fixtures	Included	Included	Included	Included	Included		
Water Closet, Floor-Mounted ADA (WC-1 & WC-2)	Included	Included	Included	Included	Included		
Lavatory w/ Manual Metering Faucet, Wall-Mounted ADA (L-1 & L-2)	Included	Included	Included	Included	Included		
Waterless Urinals (UR-1)	Included	Included	Included	Included	Included		
Classroom Sink w/ Manual Metering Faucet (S-1)	Included	Included	Included	Included	Included		
ADA Hilo Stainless Drinking Fountain (DF-1)	Included	Included	Included	Included	Included		
Service Sinks (SS-1)	Included	Included	Included	Included	Included		
Floor Drains (FD-1)	Included	Included	Included	Included	Included		
Hose Bibbs (HB-1)	Included	Included	Included	Included	Included		
Hose Bibbs on Landscape Drawings (RFI# 10)	2,000	2,000	2,000	2,000	2,000		
Trap Primers (TP-1)	Included	Included	Included	Included	Included		
Roof / Overflow Drains (RD-1 & OD-1)	Included	Included	Included	Included	Included		
Cleanouts	Included	Included	Included	Included	Included		
Gas Shut-Off Valves	Included	Included	Included	Included	Included		
Water Hammer Arrestors	Included	Included	Included	Included	Included		
All Fixtures Meet ADA	Included	Included	Included	Included	Included		
Commercial Grade Toilet Seats	Included	Included	Included	Included	Included		
Special Wrenches for Servicing	250	Included	Included	Included	Included		
Faucet Repair Kits	1,000	Included	Included	1,000	Included		
Furnish & Install All Plumbing Equipment w/ Associated Connections	Included	Included	Included	Included	Included		

Bid Evaluation Report



Plumbing

Marshall Classroom Building

Subcontractors

Description	City Commerical	HPS Mechanical	Moe	Precision Plumbing-Mechanical	Job Number	
					Suttles Plumbing	1641
					Bid Date	6/7/2017
					Date Printed	7/27/2017
<i>Manufacturers per P-001</i>	Included	Included	Included	Included	Included	
Tankless Gas Water Heaters (WH-1 & WH-2)	Included	Included	Included	Included	Included	
Circulating Pump (CP-1)	Included	Included	Included	Included	Included	
Expansion Tanks (ET-1)	Included	Included	Included	Included	Included	
Furnish & Install All Plumbing Piping	Included	Included	Included	Included	Included	
Hot and Cold Water Piping	Included	Included	Included	Included	Included	
Copper Type L Lead-Free Piping	Included	Included	Included	Included	Included	
<i>1. Lead-Free stops and white painted wire supply</i>	Included	Included	Included	Included	Included	
Waste and Vent Piping	Included	Included	Included	Included	Included	
Cast-Iron, No Hub	Included	Included	Included	Included	Included	
Storm and Roof Drain Piping	Included	Included	Included	Included	Included	
Cast-Iron, No Hub	Included	Included	Included	Included	Included	
Gas Piping	Included	Included	Included	Included	Included	
Schedule 40 Steel	Included	Included	Included	Included	Included	
Condensate Piping, HVAC	Included	Included	Included	Included	Included	
Copper Type M, Lead-Free	Included	Included	Included	Copper Type L	Included	
Connect Sewer, Storm Drain and Domestic Water	Included	Included	Included	Included	Included	
Service 5' Out	Included	Included	Included	Included	Included	
Piping Insulation as Required	Included	Included	Included	Included	Included	
Temporary Water for Construction Use (Meter by Others)	13,400	13,400	13,400	13,400	13,400	
Galvanize Flashings, Roof Jacks, Pipe Collars as Required	Included	Included	Included	Included	Included	
Sheet Metal Flashings for all Plumbing Penetrations	Included	Included	Included	Included	Included	
BIM Coordination	10,000	17,500	10,000	10,000	10,000	
Caulking and Sealants as Required	Included	Included	Included	Included	Included	
Fire Caulking, Sleeves, Fire Stopping as Required	Included	Included	Included	Included	Included	
Drilling, Boring, Cutting, Notching as Required	Included	Included	Included	Included	Included	
Earthquake Shut-Off Valves	Included	Included	Included	Included	Included	
Supports, Anchors, Seismic Bracing as Required	Included	Included	Included	Included	Included	
Safety walk and progressive cleanup	4,642	4,642	4,642	4,642	4,642	
Vibration Isolation	Included	Included	Included	Included	Included	
Access Panels as Required, Furnish Only	Included	Included	Included	Included	Included	
All Related Trenching and Backfill to 90%	Included	Included	Included	Included	Included	
Flush, Chlorinate, Disinfect and Sterilize Domestic Water	Included	Included	Included	Included	Included	
Haul Off Spoils Generated by Own Work	2,470	10,000	2,925	Included	20,000	
Provide and connect water line to construction trailer	3,350	3,350	3,350	3,350	3,350	
Temporary tool/storage bins	1,400	1,400	1,400	1,400	1,400	
Temporary Toilets	2,100	2,100	2,100	2,100	2,100	

Bid Evaluation Report

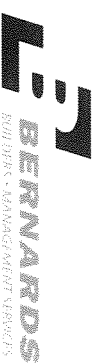

Plumbing

Marshall Classroom Building

Subcontractors

Description	City Commerical	HPS Mechanical	Moe	Precision Plumbing-Mechanical	Suttles Plumbing	Job Number	1641
						Bid Date	6/7/2017
						Date Printed	7/27/2017
Temporary Handwash facilities	2,100	2,100	2,100	2,100	2,100		
ARC:27	(2,500)	(2,500)	(2,500)	(2,500)	(2,500)		
TOTALS	355,312	403,522	375,182	454,102	473,850		0
Recommendation:						Amount	
City Commerical						355,312	

Bid Evaluation Report

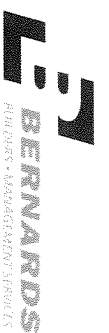

HVAC

Marshall Classroom Building

Subcontractors

Job Number **1641**
 Bid Date **6/7/2017**
 Date Printed **7/27/2017**

Description	Climate Control	J.R. Barto	Sheldon Mechanical	WR Robbins Co.
Base Bid	610,090	544,600	435,800	440,000
Spec #: 23 0000 - General Provisions	Included	Included	Included	Included
Spec #: 23 0513 - Electric Motors and Controllers	Included	Included	Included	Included
Spec #: 23 0548 - Vibration Isolation and Seismic Restraints	Included	Included	Included	Included
Spec #: 23 2500 - Water Treatment	Quality Exclude	Quality Exclude	Quality Exclude	Quality Exclude
Spec #: 23 3100 - Air Transmission and Distribution System	Included	Included	Included	Included
Spec #: 23 8000 - Air Conditioning and Air Handling Management	Included	Included	Included	Included
Spec #: 23 9000 - Building Management System	Included	Included	Included	Included
Furnished, Installed, FOB Jobsite, Tax Included	Included	Included	Included	Included
Plans and Specs Dated: 1/28/2016 & 10/4/2016	Included	Included	Included	Included
Acknowledgment of RFIs 1-75 dated 6.5.17	Included	Included	Included	Included
Bid Good for 60 Days	30 Days	30 Days	90 Days	60 Days
Prevailing Wage	Included	Included	Included	Included
Prequalified per Oxnard School District Standards	No	Yes	Yes	Yes (Chapman Air Systems, Inc.)
Attachment C Acknowledgement	Included	Included	Included	Included
Furnish & Install All HVAC Equipment				
Building Equipment	Included	Included	Included	Included
Roof-Mounted Package Units w/ Spring Isolators and Curb, AC1-AC12 - Carrier	Included	Included	Included	Included
Roof-Mounted, Exhaust Fans - Loren Cook	Included	Included	Included	Included
Ductless Split AC Units - Mitsubishi	Included	Included	Included	Included
Heating Ventilator Air Units - Reznor	Included	Included	Included	Included
Factory Curb/ Install	Included	Included	Included	Included
Furnish & Install All Ductwork and Distribution				
Sheet Metal Lined Round Ducts	Included	Included	Included	Included
Sheet Metal Rectangular Ducts	Included	Included	Included	Included
Flexible Round Ducts	Included	Included	Included	Included
Building Distribution	Included	Included	Included	Included
Supply, Return and Exhaust Ductwork	Included	Included	Included	Included
Ceiling Supply/Return/Exhaust Diffusers	Included	Included	Included	Included
Supply/Return/Exhaust Air Side Grilles	Included	Included	Included	Included
Side Wall Mounted Transfer Grilles	Included	Included	Included	Included
Outdoor Exhaust Grilles	Included	Included	Included	Included
Fire/Smoke Dampers	Included	Included	Included	Included
90° Elbows at Ceiling Diffusers	Included	Included	Included	Included
Sound Boots as Required	Included	Included	3,500	Included
Sheet Metal Louvers	Included	Included	3,800	Included

Bid Evaluation Report



HVAC

Marshall Classroom Building

Subcontractors

Job Number **1641**
 Bid Date **6/7/2017**
 Date Printed **7/27/2017**

Description	Climate Control				Mechanical			
	J.R. Barto	Sheldon	WR Robbins Co.		J.R. Barto	Sheldon	WR Robbins Co.	
Backdraft Dampers at Exhaust as Required	Included	Included	Included	Included	Included	Included	Included	
Condensate Drain Piping - 1/1M505	w/ Plumbing 10,050	w/ Plumbing 10,050	w/ Plumbing 10,050	w/ Plumbing 20,000				
22 ga galv hoods at roof ductwork per 4/M-510								
Furnish & Install HVAC Controls	Included	Included	Included	Included	Included	Included	Included	
Energy Management and Building Management Control Systems (DDC)	Included	Included	Included	Included	Included	Included	Included	
<i>MFR - Aleton</i>	Included	Included	Included	Included	Included	Included	Included	
Tie-In Controls w/ Current EMS Already Serving the Existing Campus (RFI #29)	Included	Included	Included	Included	Included	Included	Included	
All Low Voltage Wiring for Own Systems	Included	Included	Included	Included	Included	Included	Included	
All Duct Supports, Seismic Restraints, and Bracing as Required	Included	Included	Included	Included	Included	Included	Included	
HVAC Mounting - M.W. Sausse & Co, Vibrex VIC-EQ w/ Spring Mounts M-521	Included	Included	Included	Included	Included	Included	Included	
All Piping and Duct Insulation as Required	Included	Included	Included	Included	Included	Included	Included	
All Mechanical Piping as Shown on Plans	Included	Included	Included	Included	Included	Included	Included	
Sound and Vibration Control	Included	Included	Included	Included	Included	Included	Included	
Access Panels as Required - Furnish Only	Included	3,500	Included	Included	Included	Included	Included	
All Required Signage and Identification Labels	Included	Included	Included	Included	Included	Included	Included	
Splay Wires for HVAC Registers and Grilles as Required	w/ ACT	w/ ACT	w/ ACT	w/ ACT	w/ ACT	w/ ACT	w/ ACT	
Safety walk and progressive cleanup	6,218	6,218	6,218	6,218	6,218	6,218	6,218	
Construction Filters and Final Filters	Included	Included	Included	Included	Included	Included	Included	
All Sheet Metal Flashings as Required	Included	Included	Included	Included	Included	Included	Included	
Firestopping at Penetrations	Included	2,000	Included	Included	Included	Included	Included	
Testing and Balancing	Included	Included	Included	Included	Included	Included	Included	
Duct Pressure Testing	Quality Exclude	Quality Exclude	Quality Exclude	Quality Exclude	Quality Exclude	Quality Exclude	Quality Exclude	
Hoisting of Own Material as Required	Included	Included	Included	Included	Included	Included	Included	
BIM Coordination	6,700	6,700	6,700	6,700	6,700	6,700	6,700	
ARC.11	(56,000)	(56,000)	(56,500)	(56,000)	(56,000)	(56,000)	(56,000)	
ARC.24	(42,000)	(42,000)	(42,600)	(42,000)	(42,000)	(42,000)	(42,000)	
TOTALS	535,057	475,068	366,968	374,918	0	0	0	
Recommendation:	Amount							
Sheldon Mechanical	366,968							

Bid Evaluation Report



Electrical / Low Voltage

Marshall Classroom Building

Subcontractors

Description	Oilfield Electric	Reyes & Sons	Taft Electric	Venco	Job Number	
					Siemens	1641
					Date Printed	6/7/2017
					Date Printed	7/27/2017
Base Bid	1,241,580	1,075,100	989,000	1,020,000	Fire Alarm Only	
Division 26 - Electrical	Included	Included	Included	Included		
Spec #: 26 0126 - Inspection Test and Acceptance	Included	Included	Included	Included		
Spec #: 26 0500 - Common Work Results for Electrical	Included	Included	Included	Included		
Spec #: 26 0513 - Basic Electrical Materials and Methods	Included	Included	Included	Included		
Spec #: 26 0519 - Low-Voltage Wires (600 Volt AC)	Included	Included	Included	Included		
Spec #: 26 0526 - Grounding and Bonding	Included	Included	Included	Included		
Spec #: 26 0533 - Raceways and Boxes Fitting and Supports	Included	Included	Included	Included		
Spec #: 26 0586 - Motors and Drives	Included	Included	Included	Included		
Spec #: 26 0800 - Electrical Systems & Commissioning	Included	Included	Included	Included		
Spec #: 26 0923 - Lighting Control Systems	Included	Included	Included	Included		
Spec #: 26 1000 - Service Entrance	Included	Included	Included	Included		
Spec #: 26 2200 - Low Voltage Transformers	Included	Included	Included	Included		
Spec #: 26 2413 - Switchboards 1000	Included	Included	Included	Included		
Spec #: 26 2416 - Panelboards and Signal Terminal Cabinets	Included	Included	Included	Included		
Spec #: 26 2419 - Motor Control Devices	Included	Included	Included	Included		
Spec #: 26 5000 - Lighting	Included	Included	Included	Included		
Spec #: 26 5200 - Emergency Power Systems	Included	Included	Included	Included		
Spec #: 23 0513 - Electric Motors and Controllers	Included	Included	Included	Included		
Division 27 - Communications	Included	Included	Included	Included		
Spec #: 27 0126 - Test and Acceptance Requirements for Structured Cabling	Included	Included	Included	Included		
Spec #: 27 1013 - Structured Cabling	Included	Included	Included	Included		
Spec #: 27 4113 - Classroom Sound Enhancement System	Included	Included	Included	Included		
Spec #: 27 5116 - Public Address and Intercommunication Systems	Included	Included	Included	Included		
Spec #: 27 5313 - Clock and Program Systems	Included	Included	Included	Included		
Division 28 - Electronic Safety and Security	Included	Included	Included	Included		
Spec #: 28 1600 - Intrusion Detection System	Included	Included	Included	Included		
Spec #: 28 3100 - Fire Detection and Alarm System	Included	Included	Included	Included		
Furnished, Installed, FOB Jobsite, Tax Included	Included	Included	Included	Included		
Plans and Specs Dated: 1/28/2016 & 10/4/2016	Included	Included	Included	Included		
Acknowledgment of RFIs 1-75 dated 6.5.17	Included	Included	Included	Included		
Bid Good for 60 Days	30 days	60 Days	60 Days	30 Days		60 Days

Bid Evaluation Report

Electrical / Low Voltage

Marshall Classroom Building

Subcontractors

Description	Oilfield Electric		Reyes & Sons		Taft Electric		Venco		Siemens		
	Included	Yes	Included	Yes	Included	Yes	Included	Yes	Included	No	
Prequalified per Oxnard School District Standards	Included	Yes	Included	Yes	Included	Yes	Included	Yes	Included	No	
Attachment C Acknowledgement	Included		Included		Included		Included		Included		
Furnish & Install Building Electrical											
Main Gear and Panels	Included		Included		Included		Included		Included		
1200A WP Main Switch Board, 480Y/277V, 3 Phase, 4W	Included		Included		Included		Included		Included		
Panel board ("MP"/E-030)	Included		Included		Included		Included		Included		
500KVA WP Site Transformer w/ Disconnect	Included		Included		Included		Included		Included		
Distribution Boards	Included		Included		Included		Included		Included		
Panel Boards	Included		Included		Included		Included		Included		
Lighting Control Panels and Lighting Control System	Included		Included		Included		Included		Included		
Circuit Breakers	Included		Included		Included		Included		Included		
Transformers	Included		Included		Included		Included		Included		
Ground Bus / Grounding Systems	Included		Included		Included		Included		Included		
Distribution, Conduit and Wiring	Included		Included		Included		Included		Included		
Copper Bussing and Wiring w/ Rigid Conduit	Included		Included		Included		Included		Included		
Feeders (RFI# 26)	Included		Included		Included		Included		Included		
Power Distribution	Included		Included		Included		Included		Included		
Conduits & Raceways	Included		Included		Included		Included		Included		
Lighting Switches, Conduit and Wiring	Included		Included		Included		Included		Included		
Cable Trays	Included		Included		Included		Included		Included		
Terminal Cabinets & Racks	Included		Included		Included		Included		Included		
Outlet & Junction Boxes, Pull Boxes	Included		Included		Included		Included		Included		
Wiring Devices	Included		Included		Included		Included		Included		
Switches / Disconnects	Included		Included		Included		Included		Included		
Overcurrent Protection	Included		Included		Included		Included		Included		
Connections to Existing Generator	Included	2,500	Included	2,500	Included	2,500	Included	2,500	Included		
Power to Equipment	Included		Included		Included		Included		Included		
Power to Mechanical & Plumbing Equipment	Included		Included		Included		Included		Included		
Power to Misc. Equipment / Motors / Devices	Included		Included		Included		Included		Included		
Power to Electric Overhead Coiling Doors w/ Low Voltage Wiring (RFI# 62)	Included		Included		Included		Included		Included		
Power to Building Lighting w/ Controls and Panels	Included		Included		Included		Included		Included		
Power for Irrigation Controller (RFI#65)	Included		Included		Included		Included		Included		
Conduit & Back Boxes Only:	Included		Included		Included		Included		Included		
Voice / Data / CATV Systems	Included		Included		Included		Included		Included		
Computer Network Cabling System	Included		Included		Included		Included		Included		
Autonomous PA System	Included		Included		Included		Included		Included		
Occupancy / Motion Sensor System	Included		Included		Included		Included		Included		
Energy Management Systems / HVAC Controls	Included		Included		Included		Included		Included		

Bid Evaluation Report

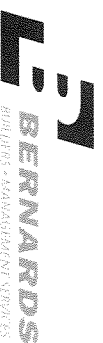

Electrical / Low Voltage

Marshall Classroom Building

Subcontractors

Description	Subcontractors				Siemens
	Oilfield Electric	Reyes & Sons	Taft Electric	Venco	
Other Low Voltage Systems (E-001)	Included	Included	Included	Included	
Temporary Power and Lighting	42,000	42,000	39,000	42,000	
Install, Maintain, Relocate for Construction Offices	Included	Included	Included	Included	
Install, Maintain, Relocate for Building Areas & Site	Included	Included	Included	Included	
Temp Power for Elevator Testing and Build Out	Included	Included	Included	Included	
Temp Power Spider Boxes	Included	Included	Included	Included	
Temp Light Strings	Included	Included	Included	Included	
Conduit and Wire to Jobsite Trailers	Included	Included	Included	Included	
Furnish & Install Building Low Voltage Systems					
Fire Alarm System	See Below	See Below	See Below	See Below	See Below
Complete Addressable Fire Alarm System (E-204 & E-304)	71,131	71,131	Included	71,131	71,131
<i>Manufacturer - Siemens</i>	Siemens Bid	Siemens Bid	Included	Siemens Bid	Included
Per City Fire Dept. Standards	Included	Included	Included	Included	Included
FACP, Annunciator, Devices, Equipment & Conductors	Included	Included	Included	Included	Included
Fire Alarm Equipment Schedule E-020	Included	Included	Included	Included	Included
Fire Alarm Details - E020-022	Included	Included	Included	Included	Included
Elevator System	Connection Only	Connection Only	Connection Only	Connection Only	Connection Only
Horns, Strobes, Pull Stations, Detectors	Included	Included	Included	Included	Included
Smoke Duct Detectors - Furnish Only	Included	Included	Included	Included	Included
Interlock to HVAC Unit Shut-Down, as shown	Included	Included	Included	Included	Included
Complete Plans / Specifications / Calculations	Included	Included	Included	Included	Included
Submittals / Shop Drawings / As-Builts	Included	Included	Included	Included	Included
Permits / Licenses / Fees	Included	Included	Included	Included	Included
Security, Intrusion and Access Control System	24,950	Included	Included	27,500	
<i>MFR - Per Specs</i>	Included	Included	Included	Included	
Computer, Monitors, and Recording Devices	By Owner	By Owner	By Owner	By Owner	
Complete	Included	Included	Included	Included	
Infrared Motion Detectors	Included	Included	Included	Included	
Interconnection with Door and Gate Hardware as Required	Included	Included	Included	Included	
Interconnection with Overhead Doors as Required	Included	Included	Included	Included	
Interconnection with Elevators as Required	Included	Included	Included	Included	
All Weather-Rated Enclosures	Included	Included	Included	Included	
All Wiring as Required	Included	Included	Included	Included	
Complete Plans / Specifications / Calculations	Included	Included	Included	Included	
Submittals / Shop Drawings / As-Builts	Included	Included	Included	Included	
Permits / Licenses / Fees	Included	Included	Included	Included	
Telecom / Data / CATV (E-203 & E-303)	Included	Included	Included	Included	
Telecom / CATV Back-Bone Cabling	Included	Included	Included	Included	

Bid Evaluation Report

Electrical / Low Voltage

Marshall Classroom Building

Subcontractors

Description	Oilfield Electric	Reyes & Sons	Taft Electric	Venco	Job Number	1641
					Bid Date	6/7/2017
					Date Printed	7/27/2017
					Siemens	
Multi-Mode & Single-Mode Fiber Optic Cable	Included	Included	Included	Included		
CAT 5E Cabling	Included	Included	Included	Included		
Voice Cabling	Included	Included	Included	Included		
Faceplates, Data and Phone Jacks	Included	Included	Included	Included		
Signal Terminal Cabinets	Included	Included	Included	Included		
All Connectors, Hangers, Labels as Required	Included	Included	Included	Included		
All Wiring as Required	Included	Included	Included	Included		
Install and Connect Owner Furnished Rack Mounted Uninterruptible Power Supplies and Ethernet Switches in Equipment Cabinets at Locations with Active Equipment.	Included	Included	Included	Included		
Submittals / Shop Drawings / As-Builts	Included	Included	Included	Included		
Permits / Licenses / Fees	Included	Included	Included	Included		
Classroom Sound Enhancement System (E-203 & E-303)	Included	Included	Included	Included		
<i>Manufacturer - Per Spec (274113, 2.01)</i>	Included	Included	Included	Included		
Infrared Technology - Dome Sensors	Included	Included	Included	Included		
Single and Multiple Input/Output Amplifiers	Included	Included	Included	Included		
Loudspeakers w/ Integral Sealed Back Can	Included	Included	Included	Included		
Wall Mounted Control Panel	Included	Included	Included	Included		
Conductors and Cabling	Included	Included	Included	Included		
Battery Chargers	Included	Included	Included	Included		
Seal all Firewalls Penetrated	Included	Included	Included	Included		
All Equipment Racks Bolted to the Floor	Included	Included	Included	Included		
Submittals / Shop Drawings / As-Builts	Included	Included	Included	Included		
Permits / Licenses / Fees	Included	Included	Included	Included		
PA and Intercommunication System (E-203 & E-303)	Included	Included	Included	Included		
<i>Manufacturer - Per Spec (275116, 2.01)</i>	Included	Included	Included	Included		
System Equipment Racks	By Owner	By Owner	By Owner	By Owner		
Central Card Cage / Shelf Assembly	By Owner	By Owner	By Owner	By Owner		
Intercom System w/ Display Telephone	Included	Included	Included	Included		
Wall Mounted Control Panel & Display Units	Included	Included	Included	Included		
Turners, CD Players, Power Amplifiers, Loudspeakers Etc.	By Owner	By Owner	By Owner	By Owner		
Terminal Blocks and Cabinets	Included	Included	Included	Included		
Conductors and Cabling	Included	Included	Included	Included		
Seal all Firewalls Penetrated	Included	Included	Included	Included		
All Equipment Racks Bolted to the Floor	Included	Included	Included	Included		
Submittals / Shop Drawings / As-Builts	Included	Included	Included	Included		
Permits / Licenses / Fees	Included	Included	Included	Included		
Master Clock System	Included	Included	Included	Included		
<i>Manufacturer - Lathem LTR8-512-M or District Approved</i>	Included	Included	Included	Included		
Power Supplies, Backboxes, Etc.	Included	Included	Included	Included		

Bid Evaluation Report

Electrical / Low Voltage

Marshall Classroom Building

Subcontractors

Description	Oilfield Electric	Reyes & Sons	Taft Electric	Venco	Siemens	
					Job Number	1641
					Bid Date	6/7/2017
					Date Printed	7/27/2017
All Wall-Mounted Clocks	Included	Included	Included	Included		
Standby Battery System (7 Days)	Included	Included	Included	Included		
All Wiring as Required	Included	Included	Included	Included		
Seal all Firewalls Penetrated	Included	Included	Included	Included		
Furnish & Install Site Electrical	Included	Included	Included	Included		
Safe-Off of Electrical For Removal of Existing Equipment, Conduit and Wiring (2/E-102)	Included	Included	Included	Included		
Removal, Replacement at Existing Site Electrical (E-102)	108,458	108,458	108,458	108,458	125,208	16,750
Surveying route of new service	Included	Included	Included	Included		
Potholing & line verification of new runs	Included	Included	Included	Included		
Demo area at new transformer/switchgear in parking lot:	Included	Included	Included	Included		
Demo curbs	Included	Included	Included	Included		
Demo Landscape/AC Paving	Included	Included	Included	Included		
AC Paving demo at dropoff	Included	Included	Included	Included		
Sawcut and demo site concrete work entire run of Electrical runs	Included	Included	Included	Included		
Add 50% more site concrete demo to go to a control or expansion joint	Included	Included	Included	Included		
Sawcut and demo AC Paving work entire run of Electrical runs	Included	Included	Included	Included		
Demo at Dirt / Landscape/Shrubs/Irrigation work entire run of Electrical runs	Included	Included	Included	Included		
New work for SCE work (E-101 & E-102)	Included	Included	Included	Included		
New Pads at new SCE transformer - 8'x10' - 1/E-102	Included	Included	Included	Included		
New Pads at new 500kva Transformer - 16'x21' - 1/E-102	Included	Included	Included	Included		
New Curbs (from Demo above)	Included	Included	Included	Included		
Put-Back Balance of Landscape/AC Paving in reworked electrical area at existing parking lot	Included	Included	Included	Included		
AC Paving at trench that crossed the Dropoff drive lane	Included	Included	Included	Included		
Possible Re-Striping	Included	Included	Included	Included		
Reinstall site concrete work entire run of Electrical runs - this appears to be colored concrete	Included	Included	Included	Included		
Reinstall the Added 50% more site concrete demo to go to a control or expansion joint	Included	Included	Included	Included		
Reinstall AC Paving work entire run of Electrical runs	Included	Included	Included	Included		
Reinstall Dirt/Landscape/Shrub/Irrigation work entire run of Electrical runs	Included	Included	Included	Included		

Bid Evaluation Report



Electrical / Low Voltage

Marshall Classroom Building

Subcontractors

Description	Oilfield Electric	Reyes & Sons	Taft Electric	Venco	Job Number	1641
					Bid Date	6/7/2017
					Date Printed	7/27/2017
					Siemens	
Furnish / Install concrete filled steel Bollards with footings	Included	Included	Included	Included		
Dry Utilities - Power	Included	Included	Included	Included		
Secondary Conduit From New On-Site Transformer to New WP Main Switchboard (Wire by SCE) (1/E-102)	Included	Included	Included	Included		
MP-1 - (3) 3" Conduit w/ (3) 350KCM & (1) #2/0 in Each Conduit (RFI# 26)	Included	Included	Included	Included		
MP-2 - (3) 3" Conduit w/ (4) 250KCM & (1) #2/0 in Each Conduit & (2) 4" Conduit for Future Power to New Pullbox to New Building (RFI# 26)	Included	Included	Included	Included		
Power to Existing "MSB" From New 500KVA Transformer	Included	Included	Included	Included		
MP-1A - (6) 3" Conduit w/ (4) 350KCM & (1) 250KCM in Each Conduit (RFI# 26)	Included	Included	Included	Included		
New Intercept Underground Pullbox and Connection to Existing Power for "MSB"	Included	Included	Included	Included		
(4) 350KCM & (1) 250KCM Wiring in Existing "MSB" Conduits	Included	Included	Included	Included		
Stub Out (2) Different Lines of (2) 4" Conduit for Future Power from New Pullbox (E-101)	Included	Included	Included	Included		
Utility Company Primary Switch	w/ SCE	w/ SCE	w/ SCE	w/ SCE		
Utility Company Site Transformer	w/ SCE	w/ SCE	w/ SCE	w/ SCE		
Conductors: by Utility Company	w/ SCE	w/ SCE	w/ SCE	w/ SCE		
Dry Utilities - Low Voltage	Included	Included	Included	Included		
(5) 2" Conduits for Low Voltage Systems (FA, SEC, Clock, PA, Tele and Data) From Existing Building to New Pullbox to New Building (E-101)	Included	Included	Included	Included		
(4) 2" Conduits for Future Low Voltage Stubbed From Existing Building to New Pullbox (E-101)	Included	Included	Included	Included		
Stub Out (2) Different Lines of (4) 2" Conduit for Future Low Voltage from New Pullbox (E-101)	Included	Included	Included	Included		
Underground Power Distribution for Site Lighting and Site Power	Assume Existing	Assume Existing	Assume Existing	Assume Existing		
Power to PIVs, Tamper Switches, Backflows	Included	Included	Included	Included		
Electrical Vaults / Pull Boxes, as required	Included	Included	Included	Included		
Traffic Rated Covers / Frames, as required	Included	Included	Included	Included		
Furnish & Install Lighting						
LED and Fluorescent Lighting as Shown	Included	Included	Included	Included		
Lighting Fixtures per Schedule on E-010	Included	Included	Included	Included		

Bid Evaluation Report



Electrical / Low Voltage

Marshall Classroom Building

Subcontractors

Description	Oilfield Electric	Reyes & Sons	Taft Electric	Venco	Siemens	Job Number	1641
						Bid Date	6/7/2017
						Date Printed	7/27/2017
Lighting Fixtures at New Classroom Building (E-201 & E-301)	Included	Included	Included	Included			
Exit Signs	Included	Included	Included	Included			
LED Lamps	Included	Included	Included	Included			
Non-LED Lamps	Included	Included	Included	Included			
Occupancy Sensors	Included	Included	Included	Included			
Spare Parts as Required (Spec. 265000, 3.03)	Included	Included	Included	Included			
Coordination of Shipping and Installation of Fixtures	Included	Included	Included	Included			
BIM Coordination (1 per Week for 2 Months)	18,425	18,425	16,750	18,425		3,000	
Plywood Backboards	w/ Rough Carp	w/ Rough Carp	w/ Rough Carp	w/ Rough Carp			
Mounting & Anchoring Details - E7.1 & 7.2	Included	Included	Included	Included			
Concrete base at Electrical Equipment 5/E-050	w/ Site Concrete	w/ Site Concrete	w/ Site Concrete	w/ Site Concrete			
Protective Bollards 2/E-050	w/ Misc. Metals	w/ Misc. Metals	w/ Misc. Metals	w/ Misc. Metals			
NEMA Enclosures, where shown	Included	Included	Included	Included			
Flashings at Penetrations	Included	Included	Included	2,000		Included	
Caulkings / Sealants	Included	Included	Included	Included		Included	
Sleeves / Fire Caulking / Firestopping, as required	Included	Included	Included	Included		Included	
Sound and Vibration control	Included	Included	Included	Included		Included	
All Block Outs, Inserts, Coring, Notching, etc.	Included	Included	Included	Included		Included	
Backfill Trenches / Bedding	Included	Included	Included	Included		Included	
Safety walk and progressive cleanup	7,772	7,772	7,772	7,772			
All Required Signage and Identification Labels	Included	Included	Included	Included		Included	
Seismic Bracing to Meet Code	Included	Included	Included	Included		Included	
Access Panels as Required - Furnish Only	Included	5,000	3,000	4,000		1,500	
Haul Off Spoils Generated by Own Work	Included	15,000	15,000	15,000			
Electrical Permits	Included	3,000	No cost	3,000			
Disconnect & reconnect existing PV panels during SCE switch-over	5,000	5,000	5,000	5,000			
Refuse signs not included on lighting fixture schedule	1,000	1,000	1,000	1,000			
ARC.25	(10,000)	(10,000)	(10,000)	(10,000)			
TOTALS	1,512,816	1,344,386	1,177,480	1,317,786		75,631	0
Recommendation:	Amount						
Taft Electric	1,177,480						

Bid Evaluation Report

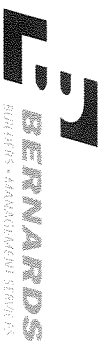

Electrical / Low Voltage

Marshall Classroom Building

Subcontractors

Description	Oilfield Electric	Reyes & Sons	Taft Electric	Venco	Siemens	Job Number	1641
						Bid Date	6/7/2017
						Date Printed	7/27/2017
Alternates							
Add Alternate (RFI#70) - Per Spec I01400 2.07B, Provide Refuse Sign not Indicated on Lighting Fixture Schedule.			\$850/ea				
Add Alternate (RFI #16) - Connect Genset w/ Power Required for Essential Equipment to run During Potential Power Outages such as Site & Parking Lot Lights, Fire Alarm Panel, Security System, and Jobsite/Trailers Related Electrical Requirements.			35,000				

Bid Evaluation Report



Demo & Earthwork

Marshall Classroom Building

Subcontractors

Job Number **1641**
 Bid Date **6/7/2017**
 Date Printed **7/27/2017**

Description	Standard Demolition	Damar Const.	Leko Const.	Toro Ent.		
Base Bid	See Below	See Below	See Below	See Below		
Spec #: 31 1000 - Site Clearing	Included	Included	Included	Included		
Spec #: 31 2200 - Grading	Included	Included	Included	Included		
Spec #: 31 2316 - Excavation & Fill Paving	Included	Included	Included	Included		
Spec #: 31 2319 - Excavation & Fill Structures	Included	Included	Included	Included		
Spec #: 31 2323 - Excavation & Fill Utilities	Included	Included	Included	Included		
Spec #: 31 2326 - Base Course	Included	Included	Included	Included		
Soil Report: by CTE South dated 7/11/16	Included	Included	Included	Included		
Bond Rate (if required)						
Furnished, Installed, FOB Jobsite, Tax Included	Included	Included	Included	Included		
Plans and Specs Dated: 1/28/2016 & 10/4/2016	Included	Included	Included	Included		
Acknowledgment of RFI's 1-75 dated 6.5.17	Included	Included	Included	Included		
Bid Good for 60 Days	Included	Included	Included	Included		
Prevailing Wage	Included	Included	Included	Included		
Prequalified per Oxnard School District Standards	N/A	N/A	N/A	N/A		
Attachment C Acknowledgement	N/A	N/A	N/A	N/A		
Demolition						
Demolition Plan C-101, at New Building location	35,467	32,985	35,467	35,467	No Bid	
Demolition Plan C-102, at Reworked Existing Parking Lot area	Included	Included	Included	Included		
Demolition Plan C-103, at New Play Area location	Included	Included	Included	Included		
Underground Utility Location, Potholing, Capping or Disconnecting Utilities	5,000	5,000	5,000	5,000		
Removal Notes:	Included	Included	Included	Included		
1 - Remove existing asphalt pavement & base, full depth	Included	Included	Included	Included		
2 - Clear, grub & remove existing turf/planter/exposed subgrade area	Included	Included	Included	Included		
3 - Remove existing shrubs, trees and roots	Included	Included	Included	Included		
4 - Remove existing catch basin	Included	Included	Included	Included		
5 - Remove Play area, including the existing play structure (Per RFI#11)	Included	1,500	Included	Included		
6 - Sawcut existing & remove existing pavement, curb or v-gutter	Included	Included	Included	Included		
7 - Remove existing curb	Included	Included	Included	Included		
8 - Remove existing utilities (identified)	Included	Included	Included	Included		
9 - Sandblast existing striping	Included	Included	Included	Included		
10 - Contractor to rework existing irrigation as needed to allow for new const. Provide shop drawings for approval of revised/reworked irrigation system prior to re-installation	w/ Landscape	w/ Landscape	w/ Landscape	w/ Landscape		
11 - Remove existing concrete V-gutter	Included	Included	Included	Included		
12 - Remove sign in its entirety	Included	Included	Included	Included		
30-39 - Protect-In-Place items as noted	Included	Included	Included	Included		

Bid Evaluation Report



Demo & Earthwork

Marshall Classroom Building

Subcontractors

Description	Standard Demolition	Damar Const.	Leko Const.	Toro Ent.	Job Number	1641
					Bid Date	6/7/2017
					Date Printed	7/27/2017
Demo Mobilizations	1,000	Included	Includes 2 ea	Includes 2 ea		
Add for demo of existing handball court walls & footings	Excluded	Excluded	Excluded	Excluded		
Grading	No Bid	94,720	108,940	96,507		
See General Civil Notes pertaining to your scope - C-001		Included	Included	Included		
Water Meter and Construction Watering for Own Scope		1,000	1,000	1,000		
Erosion Control for your work (none shown on drawings)		2,500	2,500	2,500		
Haul route for your work		Included	Included	Included		
Move-Ins as required		Included	Included	Included		
July '17 Move-On		Included	Included	Included		
Include per Composite Grading Plan C-300,301,302 and Grading Sections C-303-304		Included	Included	Included		
Mass Excavation and Fine Grade Subgrade		Included	Included	Included		
Soils Report: #5.2-Site Preparation, Geotechnical & Grading Notes: C-001		Included	Included	Included		
Temp Soil Stabilization (if required)		Included	Included	Included		
Over-Ex to suitable native soils (varies across site, but generally lie approx 4' below current grades) or minimum 42" below bottom of all footings, whichever depth is greatest		Included	Included	Included		
See Structural detail 15/S-400A, Typical Foundation & Slab Subgrade - excavation to 42" below footing and 60" below finish grade		Included	Included	Included		
Extend 5' from Perimeter Edges		Included	Included	Included		
Onsite existing fill disturbed for agricultural activities and native materials are suitable for use as fill and backfill materials		Included	Included	Included		
Over-Ex at Elevator Pit		Included	Included	Included		
Over-Ex 24" at Site Conditions - AC Paving, Site concrete, Unit Pavers, Play Area surfacing		Included	Included	Included		
Sub-Grade Compaction of 90%		Included	Included	Included		
At PCC Pavers: removal, excavation and recompaction of top 24" to 95%		Included	Included	Included		
New Play Area: C-103, 9/C-702		Included	Included	Included		
Overexcavate & recompact area after demo, ready for perimeter concrete curb (by others)		Included	Included	Included		
Include Type 2 sub-base to 95% compaction - thickness to be 4"		5,000	5,000	5,000		
Geofabric over subbase, per cut sheet from RFI#12 response - provide Alternate Add		Not required	Not required	Not required		
Excavation for mow strips		2,500	Included	Included		

Bid Evaluation Report



Demo & Earthwork

Marshall Classroom Building

Subcontractors

Job Number 1641
 Bid Date 6/7/2017
 Date Printed 7/27/2017

Description	Standard Demolition	Subcontractors				
		Damar Const.	Leko Const.	Toro Ent.		
Fine Grading for Sitework	-----	Included	Included	Included		
Export Spoils Stockpiled by Others	-----	\$XX / CY	\$XX / CY	\$XX / CY		
Concrete Footing Spoils, Structural	-----	8,125	8,125	8,125		
Concrete Footing Spoils, Site	-----	1,250	1,250	1,250		
Site Utilities	-----	2,500	2,500	2,500		
Plumbing, Electrical	-----	2,500	2,500	2,500		
Dust Control during construction		16,884	16,884	16,884		
TOTALS	0	176,464	189,166	176,733	0	0
Recommendation:	Amount					
Damar Const.	176,464					

Bid Evaluation Report

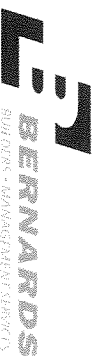

Asphalt Paving & Striping

Marshall Classroom Building

Subcontractors							Job Number	1641
							Bid Date	6/7/2017
							Date Printed	7/27/2017
							Berry Engineering	B&M Contractors
Description	ABC Resources	Onyx Paving	Toro Ent.	Excel Paving				
Base Bid	0	35,440	See below	64,950		37,772	49,825	
Spec #: 31 2316 - Excavation & Fill Paving	-----	Included	Included	Included		Included	Included	
Spec #: 31 2326 - Base Course	-----	Included	Included	Included		Included	Included	
Spec #: 32 0117 - Pavement Repair	-----	Included	Included	Included		Included	Included	
Spec #: 32 1216 - Asphalt Paving	-----	Included	Included	Included		Included	Included	
Spec #: 32 1236 - Seal for Bituminous Surfacing	Included	Included	Included	Included		Included	Included	
Bond Rate (if required)								
Furnished, Installed, FOB Jobsite, Tax Included	Included	Included	Included	Included		Included	Included	
Plans and Specs Dated: 1/28/2016 & 10/4/2016	Included	Included	Included	Included		Included	Included	
Acknowledgment of RFIs 1-75 dated 6.5.17	Included	Included	Included	Included		Included	Included	
Bid Good for 60 Days	Included	Included	Included	Included		Included	Included	
Prevailing Wage	Included	Included	Included	Included		Included	Included	
Prequalified per Oxnard School District Standards	N/A	N/A	N/A	N/A		N/A	N/A	
Attachment C Acknowledgement	N/A	N/A	N/A	N/A		N/A	N/A	
AC Paving								
See Legend on C-002:	No Bid	Included	Included	Included		Included	Included	
Eastside of New Building - 3" thk AC Surfacing over 7" thk crushed aggregate base (CAB), per 1/C-702	-----	Included	Included	Included		Included	Included	
Fire Lane, 4" thk (2" Class C2 & 2" Class B) AC Surfacing over 9" thk crushed aggregate base (CAB), per 1/C-702	-----	Included	15,538	Included		Included	Included	
Include the Pavement-to-pavement joint detail, 4/C-702	-----	Included	Included	Included		Included	Included	
Existing Parking Lot Rework, C-202	-----	Included	Included	Included		Included	Included	
Sawcut and removal of existing paving (C-102)	-----	Included	Included	Included		Included	Included	
Remove, reinstall base & recompact subgrade if unsuitable per 32.01.17.3.02.B	-----	w/ Demo	w/ Demo	w/ Demo		w/ Demo	w/ Demo	
3" thk AC Surfacing over 7" thk crushed aggregate base (CAB), per 1/C-702	-----	Included	27,966	Included		Included	Included	
Redwood Header at Grass	-----	Included	Included	Included		Included	Included	
Final 2 coat Seal over new paving per specs	-----	2,850	Included	Included		Included	Included	
Clean, Re-Seal, Re-Stripe existing Playground area, not shown	Excluded	Excluded	Excluded	Excluded		Excluded	Excluded	
Striping & Signage								
Existing Parking Lot - Striping Plan C-204	9,275	No Bid	No Bid	No Bid		No Bid	No Bid	
Sandblast existing striping at existing lot per Demo sheet C-102	Included	8,790	10,820	10,820		10,820	10,820	
Installation of new work at Existing Parking Lot: Standard Parking Spaces - 4" thk white lane per Caltrans Std Plan A20B, detail 27B	Included	Included	-----	-----		-----	-----	
Stripe Crosshatch Areas	Included	Included	-----	-----		-----	-----	

Bid Evaluation Report

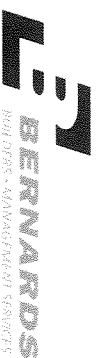

Asphalt Paving & Striping

Marshall Classroom Building

Subcontractors

Description	ABC Resources	Onyx Paving	Toro Ent.	Excel Paving	Job Number	1641
					Date Printed	6/7/2017
					Berry Engineering	B&M Contractors
					7/27/2017	
Stripe Arrows	Included	Included	-----	-----	-----	-----
Fire Lane Curbs Red - none shown	Included	Included	-----	-----	-----	-----
Accessible Parking Spaces - see A-104	Included	Included	-----	-----	-----	-----
Concrete Wheel Stops at Accessible parking - 32 13	Included	Included	-----	-----	-----	-----
13, 2.01, C.1-3 & 13/A-105	Included	Included	-----	-----	-----	-----
Precast 6' length x 6" ht doweled into paving per detail	Included	Included	-----	-----	-----	-----
Signage - Accessible sign w/ Posts & footing - 1, 9/A-105	Included	Included	-----	-----	-----	-----
Existing Fire Lane road in front of new Building - FLS Plan G-003	Included	Included	-----	-----	-----	-----
Signage - Fire Access Entrance Signage w/ Post & footing - Sheet Note #5	Included	Included	-----	-----	-----	-----
Signage - New Fire Lane Sign w/ Post & footing - Sheet A-101 & 2/A105 (same as above)	Included	Included	-----	-----	-----	-----
Striping - "Where curb occurs, Paint curb Red to designate Fire Lane" - G-003	Included	Included	-----	-----	-----	-----
Striping - "Fire flush to adjacent surface, paint 'No Parking Fire Lane' w/ Red Lettering" - G-003	Included	Included	-----	-----	-----	-----
Existing Hopscotch, Foursquare, Tetherball adjacent to site RE-Striping - Allowance	1,000	1,000	-----	-----	-----	-----
Existing Main Entry into School - A-101	Included	Included	-----	-----	-----	-----
Signage - New "Tow Away" Sign w/ Post & footing - 7/A-105	Included	500	-----	-----	-----	-----
TOTALS	0	48,580	54,324	75,770	48,592	60,645
Recommendation:	Amount					
Onyx Paving	48,580					

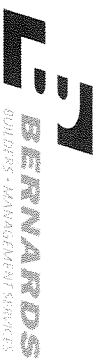

Bid Evaluation Report

Site Concrete

Marshall Classroom Building

Subcontractors

Description	B&M Contractors	Barcelo Concrete	Santa Clarita Concrete	Toro Ent.	Job Number	1641
					Bid Date	6/7/2017
					Date Printed	7/27/2017
					Berry Engineering	
Base Bid	176,900	267,864	135,000	See below	145,960	
Spec # : 31 2316 - Excavation & Fill Paving	Included	Included	Included	Included	Included	
Spec # : 31 2319 - Excavation & Fill Structures	Included	Included	Included	Included	Included	
Spec # : 31 2326 - Base Course	Included	Included	Included	Included	Included	
Spec # : 32 1313 - Site Concrete Work	Included	Included	Included	Included	Included	
Bond Rate (if required)		Bond @ 1%	Bond @ 1%	Bond @ 1%	Bond @ 1%	
Furnished, Installed, FOB Jobsite, Tax Included	Included	Included	Included	Included	Included	
Plans and Specs Dated: 1/28/2016 & 10/4/2016	Included	Included	Included	Included	Included	
Acknowledgment of RFIs 1-75 dated 6.5.17	Included	Included	Included	Included	Included	
Bid Good for 60 Days	30 Days	90 days	30 Days	30 Days	30 Days	
Prevailing Wage	Included	Included	Included	Included	Included	
Prequalified per Oxnard School District Standards	N/A	N/A	N/A	N/A	N/A	
Attachment C Acknowledgement	N/A	N/A	N/A	N/A	N/A	
On Site						
Existing Parking Lot Rework, C-202	Included	Included	Included	12,522	Included	
Sawcut and removal of existing site concrete (C-102)	w/ Demo	w/ Demo	w/ Demo	w/ Demo	w/ Demo	
Remove, reinstall base & recompact subgrade per Note 6, Det 3/C-703	w/ Grading	w/ Grading	w/ Grading	w/ Grading	w/ Grading	
Note 12 - Concrete Curb per det 3/C-703	Included	Included	Included	Included	Included	
6" concrete curb w/ (2) #4 bars continuous length of curb	Included	Included	Included	Included	Included	
At New revised Accessible spaces, it is assume use of existing concrete handicap ramps at existing diagonal layout	Qualification	Qualification	Qualification	Qualification	Qualification	
Sandblasting (by demo), Re-Striping (by Striper) will be laid-out to reuse concrete ramps	by Others	by Others	by Others	by Others	by Others	
This subcontractor will install Truncated Domes at existing ramps per A-104 & det 5/A-105, 2 ea 3'x4' min	Excluded	Excluded	Excluded	Excluded	Excluded	
Truncated Domes to be Armor Tile or equal per detail 6/C-703	Excluded	Excluded	Excluded	Excluded	Excluded	
Per SCE Drawings & E sheets:						
Transformer Pad - 2/E-020	Included	10,400	Included	10,400	10,400	
Install concrete-filled steel bollards 2/E-020	Included	2,000	2,000	2,000	2,000	
New Rubber Surfacing at existing playground area adjacent to new building, C-203						
Note 13 - Concrete Curb per det 9/C-702	Included	Included	Included	22,332	Included	
6" wide concrete curb at perimeter of play area	Included	Included	Included	Included	Included	
Includes removal, excavation and recompaction of top 24" to 95%	w/Demo, Grading	w/Demo, Grading	w/Demo, Grading	w/Demo, Grading	w/Demo, Grading	

Bid Evaluation Report



Site Concrete

Marshall Classroom Building

Subcontractors

Description	Subcontractors				Toro Ent.	Job Number 1641
	B&M Contractors	Barcelo Concrete	Santa Clarita Concrete	Berry Engineering		
4" Minimum Base course compacted & ready for rubber surfacing	3,575	3,575	3,575	3,575	3,575	6/7/2017
New handball walls & footings complete adjacent new playground area, not shown	Excluded	Excluded	Excluded	Excluded	Excluded	7/27/2017
Site Concrete Work at New Building:	Included	Included	Included	126,878	Included	
6" thk Concrete Pavement ove 4" crushed aggregate base (CAB), listed on legend C-002 & per 5/C-702(concrete pavement section detail)	Included	Included	Included	Included	Included	
Rebar #4 @ 18" ocev	w/ Rebar Included	w/ Rebar Included	w/ Rebar Included	w/ Rebar Included	w/ Rebar Included	
Site Control Plan C-201	Included	Included	Included	Included	Included	
Note 1 - 6" thk conc pavement over 4" CAB per 5/C-702	Included	Included	Included	Included	Included	
Note 2 - PCC Pavers & Sand Base per 1/C-703	Included	24,700 Included	24,700 Included	Included	Included	
Pavers MFR-None listed	Included	Included	Included	Angelus	Included	
24" wide concrete curb at perimeter of PCC Pavers	Included	2,130	2,130	Included	Included	
6" concrete Sub-Slab w/ #4@18"ocew under pavers	Included	4,940	4,940	Included	Included	
Includes removal, excavation and recompaction of top 24" to 95%	w/Demo,Grading	w/Demo,Grading	w/Demo,Grading	w/Demo,Grading	w/Demo,Grading	
Fine Grading prior to your work	Included	Included	Excluded	Excluded	Excluded	
Note 3 - Planter area per Landscape drawings	w/ Landscape w/ Grading	w/ Landscape w/ Grading	w/ Landscape w/ Grading	w/ Landscape w/ Grading	w/ Landscape w/ Grading	
Note 4 - Regrade & resurface the turf area	Included	Included	Included	Included	Included	
Note 5 - 60" Mow Strip at Perimeter of New Building - 2/C-703	Included	Included	Included	Included	Included	
New mowstrip is 12" thk Including over 4" CAB compacted to 95%	Included	Included	Included	Included	Included	
Note 6 - Seat Wall/CIP Benches per Architectural drawings, A-103	Included	Included	Included	28,728	Included	
L-Shaped 20', 4 each: Straight 10', 1 each Detail 10 & 11/A-105 - 1'6"wide x 1'-6" ht CIP Concrete w/ rebar	Included	Included	Included	Included	Included	
Note 7 - Asphalt Pavement per 1/C-702	w/ AC Paving	w/ AC Paving	w/ AC Paving	w/ AC Paving	w/ AC Paving	
Note 8 - Concrete Pavement to Asphalt Pavement Transition 2/C-702	Included	Included	Included	Included	Included	
Note 9 - New Pavement to existing Pavement Joint - 4/C-702	Included	Included	Included	Included	Included	
Note 10 - AC Pavement thickness transition - 7/C-702	w/ AC Paving	w/ AC Paving	w/ AC Paving	w/ AC Paving	w/ AC Paving	
Note 11 - Stairs per Architectural drawings 6/A-105 - Typical CIP stair nosing - extruded aluminum contrasting strip nosing - NO CIP Stairs shown	w/ Steel & CIP	w/ Steel & CIP	w/ Steel & CIP	w/ Steel & CIP	w/ Steel & CIP	
Note 12 - Concrete Curb 3/C-703	Included	Included	Included	Included	Included	

Bid Evaluation Report



Site Concrete

Marshall Classroom Building

Subcontractors

Description	Subcontractors				Engineering
	B&M Contractors	Barcelo Concrete	Santa Clarita Concrete	Toro Ent.	
Note 13 - Rubber Mat Curb - 9/C-702	Included	NEED	Included	Included	Berry Included
Note 14 - Gravity Wall - 7/C-703	Included	Included	Included	Included	Included
Note 15 - Planter Wall per Architectural & Structural drawings - 2 shown on S-211 & 6/S401	w/ CIP Concrete	Yes incl w/ site	w/ CIP Concrete	w/ CIP Concrete	w/ CIP Concrete
Note 15 - Planter Wall per Architectural & Structural drawings - 2 shown near stairs are NOT on S sheets, 36'x8'	w/ CIP Concrete	(30,000)	w/ CIP Concrete	Excluded	Excluded
6/S-401 - 1'-0" thk wall, 1'-6" above grade	w/ CIP Concrete	Yes incl w/ site	w/ CIP Concrete	w/ CIP Concrete	w/ CIP Concrete
Note 16 - Not Used	-----	-----	-----	-----	-----
Note 17 - Rubber Mat per Architectural drawings	w/ Play Equip	w/ Play Equip	w/ Play Equip	w/ Play Equip	w/ Play Equip
Base for all Site Concrete Paving	Included	Included	Included	Included	Included
Reinforcing Steel for All Work	Included	12,025	12,025	12,025	12,025
Control and Expansion Joints / Sealants	Included	Included	Included	Included	Included
Washout Bins	Included	2,500	2,500	Included	2,500
Mock-Ups	Included, if reqd	6,000	6,000	5,575	6,000
SIT.1	(7,000)	(7,000)	(7,000)	(7,000)	(7,000)
SIT.2	(15,000)	(15,000)	(15,000)	(15,000)	(15,000)
SIT.4	(5,000)	(5,000)	(5,000)	(5,000)	(5,000)
SIT.7	(6,000)	(6,000)	(6,000)	(6,000)	(6,000)
TOTALS	147,475	281,534	159,870	191,035	149,460
Recommendation:	Amount				
B&M Contractors	147,475				

Bid Evaluation Report

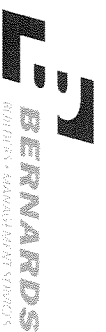

Playfield Equipment

Marshall Classroom Building

Subcontractors

Description	Miracle Playground / Central Coast Playgrounds	Dave Bang Associates / Miracle Playground	SpectraTurf / Miracle Playground	Job Number	1641
				Bid Date	6/7/2017
				Date Printed	7/27/2017
Base Bid	See below	See below	See below		
Spec #: 11 6800 - Playfield Equipment and Structures (Not Provided)	Included	Included	Included		
Spec #: 02 88 00 - Playfield Equipment and Structures (RFI#11 Response)	Included	Included	Included		
Bond Rate (if required)	N/A	Not provided	Bond at 1.5%		
Furnished, Installed, FOB Jobsite, Tax Included	Included	Included	Included		
Plans and Specs Dated: 1/28/2016 & 10/4/2016	Included	Included	Included		
Acknowledgment of RFI's 1-75 dated 6.5.17	Included	Included	Included		
Bid Good for 60 Days	90 Days	30 days	Included		
Prevailing Wage	Included	Included	Included		
Prequalified per Oxnard School District Standards	N/A	N/A	N/A		
Attachment C Acknowledgement	N/A	N/A	N/A		
Playfield Equipment & Structures - Miracle Playgrounds	0	37,210	37,210		
Furnish Modular Units complete FOB Jobsite	Included	Included	Included		
Unloading equipment at jobsite	Included	600	600		
Custom Playground by Miracle Recreation Equipment	Included	Included	Included		
Product spec & cut sheets in RFI#11	Included	Included	Included		
Separate price for Installation:	Included	Included	Included		
Include excavation, layout installation of footings	Included	Included	Included		
Sub provided by Miracle, Central Coast Playgrounds	Included	Included	Included		
Excavate, haul spoils, place embed, install rebar(is this reqd?), place concrete, cleanup	Included	Included	Included		
Footing X: 18" dia x 24" deep	0	8,050	8,050		
Footing Y: 12" dia x 18" deep	0	5,250	5,250		
Footing Z: 20" dia x 42" deep	0	500	500		
Uncrate, separate, install all parts, dispose of empty boxes	0	3,500	3,500		
Playfield Rubber Matting					
Furnish & install complete playground surface as MFR by PlayMax or equal	-----	45,416	42,471		
Demolition Plan C-103, at New Play Area location, remove existing AC Paving	-----	w/ Demo	w/ Demo		
Overexcavate & recompact area after demo	-----	w/ Grading	w/ Grading		

Bid Evaluation Report

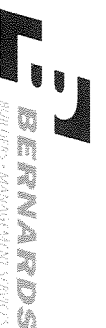

Playfield Equipment

Marshall Classroom Building

Subcontractors

Job Number: 1641
 Bid Date: 6/7/2017
 Date Printed: 7/27/2017

Description	Miracle Playground Equipment / Central Coast Playgrounds	Dave Bang Associates / Miracle Playground	SpectraTurf / Miracle Playground	Amount	
				103,207	100,262
Type 2 sub-base to 95% compaction - thickness to be 4"		w/ Grading	Included		
Geofabric over subbase		2,681	2,681		
Sheet C-203, Note 13 - Rubber Mat Curb - 9/C-702 around perimeter of rubber matting		w/ Site Concrete	w/ Site Concrete		
Rubber Matting subs work:		Included	Included		
MaxPour Cushion Layer - thickness to be xx?		Included	Included		
MaxPour/MaxPour-Supreme Top Layer - thickness to be xx?		Included 4"	Included 4"		
Per cut sheet two products are shown, MaxPour Supreme is not included in price		Tot Turf	SpectraPour		
Max fall height your bid is based upon		Included 9'	Included 10'		
Wear Layer to be 50% black/50% color w/ std aromatic resin		Included	Included		
See detail sheet, possible VE to install over aged asphalt paving		Not recommended	N/A		
Upgrade to Aliphatic (UV-stable, non-yellowing) Resin wear layer		No bid	Add: \$4,934		
Drywell at Rubber Mat Curb at new Play Area Rubber Surfacing 9/C-702, drain shown on C-402		w/ Site Utilities	w/ Site Utilities		
TOTALS		0	103,207	100,262	0
Recommendation:		Amount			
SpectraTurf / Miracle Playground		100,262			

Bid Evaluation Report

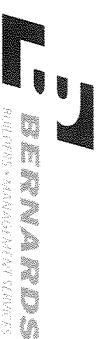

Landscape & Irrigation

Marshall Classroom Building

Subcontractors

Description	Advanced Land. 2000				Job Number Bid Date	1641 6/7/2017
	Cascade Sprinklers	Durau Landscape	Hardy	Plowboy		
Base Bid	29,418	30,500	24,320	46,800	39,600	36,068
Spec #: 323000, 328400, 329000, 329010	Included	Included	Included	Included	Included	Included
Drawings: Planting & Irrigation Specs are also Listed on Sheet L-4	Included	Included	Included	Included	Included	Included
Bond Rate (if required)						
Furnished, Installed, FOB Jobsite, Tax Included	Included	Included	Included	Included	Included	Included
Plans and Specs Dated: 1/28/2016 & 10/4/2016	Included	Included	Included	Included	Included	Included
Acknowledgment of RFIs 1-75 dated 6.5.17	Included	Included	Included	Included	Included	Included
Bid Good for 60 Days	30 Days	30 Days	30 Days	90 days	Included	Included
Prevailing Wage	Included	Included	Included	Included	Included	Included
Prequalified per Oxnard School District Standards	N/A	N/A	N/A	N/A	N/A	N/A
Attachment C Acknowledgement	N/A	N/A	N/A	N/A	N/A	N/A
Landscaping & Irrigation:						
Demolition Plan C-101, at New Building location	Included	Included	Included	Included	Included	Included
Removal Notes:	Included	Included	Included	Included	Included	Included
10 - Contractor to rework existing irrigation as needed to allow for new const. Provide shop drawings for approval of revised/reworked irrigation system prior to re-installation	2,500	2,500	2,500	2,500	2,500	2,500
At New Building per Site Control Plan C-201 & L-1	Included	Included	Included	Included	Included	Included
Note 3 - Planter area per Landscape drawings	Included	Included	Included	Included	Included	Included
Irrigation inside the CIP Planters - L-1	Included	Included	Included	Included	Included	Included
Include tapping into existing mainline for new lines	5,000	5,000	5,000	5,000	5,000	5,000
Sawcut & remove AC paving & put back for access to mainline tap-in	3,000	3,000	3,000	3,000	3,000	3,000
New mainlines & lateral lines for irrigation & rigid pvc for control wire	Included	Included	Included	Included	Included	Included
Include sleeving as required	Included	Included	Included	Included	Included	Included
New Automatic Controller Assembly - Irritrol, 10/L-3	Included	Included	Included	Included	Included	Included
Include Rain Shut-off Sensor	Included	Included	Included	Included	Included	Included
Include remote control valves & gate valves, 1 & 5/L-3	Included	Included	Included	Included	Included	Included
Include quick couplers, 2/L-3	Included	Included	Included	Included	Included	Included
Include pop-up shrub heads, 4/L-3	Included	Included	Included	Included	Included	Included
Electrical to controller	w/ Electrical	w/ Electrical	w/ Electrical	w/ Electrical	w/ Electrical	w/ Electrical
Landscaping inside the CIP Planters - L-2	Included	Included	Included	Included	Included	Included
Trees - 24" box, including Staking per 3/L-3	Included	Included	Included	Included	Included	Included
Shrubs - 1 & 5 gallon	Included	Included	Included	Included	Included	Included
Vines - 15 gallon	Included	Included	Included	Included	Included	Included
Ground Cover	Included	Included	Included	Included	Included	Included
Safety walk and progressive cleanup	4,640	4,640	4,640	4,640	4,640	4,640
90 Day Maintenance	Included	Included	Included	Included	Included	Included

Bid Evaluation Report



Landscape & Irrigation

Marshall Classroom Building

Subcontractors

Description	Subcontractors				Job Number	Bid Date	Date Printed	Venco Western
	Advanced Land. 2000	Cascade Sprinklers	Dufau Landscape	Hardy				
(1) Year Warranty	Included	Included	Included	Included	1641	6/7/2017	7/27/2017	Included
Spills Removal	200	200	200	200				200
Move-Ins (2)	1,500	1,500	1,500	1,500				1,500
Existing Parking Lot Rework, C-202	5,000	5,000	5,000	5,000				5,000
Removal & reinstallation of Irrigation at Demoeed areas	Included	Included	Included	Included				Included
Removal & reinstallation of Planting at Demoeed areas	Included	Included	Included	Included				Included
Existing Grass Field	35,185	35,185	35,185	35,185				35,185
Modify existing Irrigation at grass playground for trailer/laydown area	Included	Included	Included	Included				Included
Geofabric over the grass, rock surface as base during operations	Included	Included	Included	Included				Included
Removal of rock & geofabric at project completion	Included	Included	Included	Included				Included
Regrade, fine grade ready for new grass at laydown area	Included	Included	Included	Included				Included
Rework & start-up existing Irrigation heads	Included	Included	Included	Included				Included
Reinstallation of Grass Planting, hydroseed, at laydown area	Included	Included	Included	Included				Included
TOTALS	86,443	87,525	81,345	103,825				96,625
Recommendation:	Amount							
Dufau Landscape	81,345							

Bid Evaluation Report

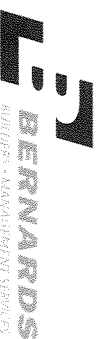

Site Utilities

Marshall Classroom Building

Description	Subcontractors				Suttles Plumbing	Toro Ent.
	BSN Construction	J. Vega Engineering	HPS Mechanical	Sam Hill & Sons		
Base Bid	217,229	See below	200,390	See below	245,000	
Spec #: 31 2319 - Excavation & Fill Structures	Included	Included	Included	Included	Included	
Spec #: 31 2323 - Excavation & Fill Utilities	Included	Included	Included	Included	Included	
Spec #: 31 2326 - Base Course	Included	Included	Included	Included	Included	
Spec #: 33 1100 - Site Water Distribution Utilities	Included	Included	Included	Included	Included	
Spec #: 33 3000 - Site Sanitary Sewer Utilities	Included	Included	Included	Included	Included	
Spec #: 33 4000 - Storm Drainage Utilities	Included	Included	Included	Included	Included	
Bond Rate (if required)	Not listed	Not listed	Not listed	Not listed	Bond @1.44%	
Furnished, Installed, FOB Jobsite, Tax Included	Included	Included	Included	Included	Included	
Plans and Specs Dated: 1/28/2016 & 10/4/2016	Included	Included	Included	Included	Included	
Acknowledgment of RFIs 1-75 dated 6.5.17	Included	Included	Included	Included	Included	
Bid Good for 60 Days	30 days	30 days	30 days	30 days	30 days	
Prequalified per Oxnard School District Standards	Included	Included	Included	Included	Included	
Attachment C Acknowledgement	N/A	N/A	N/A	N/A	N/A	
Site Utilities						
Utility Location (C Below)	Included	Included	Included	Included	Included	
Cutting and Capping of Existing Utilities	2,500	2,500	2,500	2,500	2,500	
Layout and Trenching	Included	Included	Included	Included	Included	
Sawcutting & removal of surface for New Utilities	Included	3,584	3,584	3,584	3,584	
Traffic Control	Included	Included	Included	Included	Included	
Temp Asphalt Trench Plates	Included	2,048	2,048	2,048	2,048	
Excavation Spoils Stockpile	Included	Included	Included	Included	Included	
Pressure Test and Flush System	Included	Included	Included	Included	Included	
Sewer						
Site Utility Plan C-401,402,403,404	Included	Included	Included	Included	Included	
Note 20 - Install SDR-353 Sanitary Sewer line per 4/C-701	Included	Included	Included	Included	Included	
Note 21 - Connect to bldg sanitary sewer	Included	Included	Included	Included	Included	
Note 22 - Connect to existing onsite main line	Included	Included	Included	Included	Included	
Note 23 - Install Clean-out per 7/C-701	Included	Included	Included	Included	Included	
Note 24 - Connect to onsite main line per 2/C-701	Included	Included	Included	Included	Included	
Note 25 - House connection per APWA Std Plan 222-2	Included	Included	Included	Included	Included	
Storm Drain						
Site Utility Plan C-401,402,403,404	Included	173,320	Included	143,618	Included	
Note 1 - Install SDR-35 storm drain line per 4/C-701	Included	Included	Included	Included	Included	
Note 2 - Construct 12"x12" catch basin per 6/C-701	Included	Included	Included	Included	Included	
Note 3 - Connect to existing onsite main line per 2/C-701	Included	Included	Included	Included	Included	

Bid Evaluation Report



Site Utilities

Marshall Classroom Building

Subcontractors

Description	Subcontractors					Job Number	1641
	BSN Construction	J. Vega Engineering	HPS Mechanical	Sam Hill & Sons	Suttles Plumbing	Bid Date	6/7/2017
						Date Printed	7/27/2017
						Toro Ent.	
Note 4 - Install Clean-out per 7/C-701	Included	Included	Included	Included	Included		
Note 5 - Install Arturn grate NDS 1280 & catch basin 1200 or equal	Included	Included	Included	Included	Included		
Note 6 - Connect to on-site main line per 2/C-702	Included	Included	Included	Included	Included		
Note 7 - Connect to bldg storm drain line	Included	Included	Included	Included	Included		
Note 8 - Install SDR-21 storm drain line per 4/C-701	Included	Included	Included	Included	Included		
Note 9 - Install French Drain per 2/C-704	Included	Included	Included	Included	Included		
Other: Trench Drain concrete basin per 4/S-400A	Included	Included	Included	Included	Included		
Drywell at Rubber Mat Curb at new Play Area Rubber Surfacing 9/C-702, drain shown on C-402	Included	Included	Included	Included	Included		
Water							
Site Utility Plan C-401,402,403,404	Included	64,295	Included	Included	33,353	Included	
Note 30 - Connect to existing onsite main line	Included	Included	Included	Included	Included	Included	
Note 31 - Install 4" Double Check Detector Backflow Preventer Assembly with Fire Department Connection per 3/C-701, Ames 3000 SS OS&Y w/ Tamper Switches connected to Fire Alarm	Included	Included	Included	Included	Included	Included	
Note 32 - Install AWWA C900 PVC pressure Class 200 Water line per 4/C-701	Included	Included	Included	Included	Included	Included	
Note 33 - Install concrete thrust block per 4/C-703	Included	Included	Included	Included	Included	Included	
Note 34 - Connect to bldg Fire Water connection	Included	Included	Included	Included	Included	Included	
Note 35 - Connect to building Domestic Water connection	Included	Included	Included	Included	Included	Included	
Note 36 - Connect to existing onsite main line	Included	Included	Included	Included	Included	Included	
Note 37 - Install Gate valve per 5/C-701	Included	Included	Included	Included	Included	Included	
Note 38 - Fire Department Connection per 1/C-704	Included	Included	Included	Included	Included	Included	
Note 39 - Connect to onsite main water line	Included	Included	Included	Included	Included	Included	
Includes:	Included	Included	Included	Included	Included	Included	
Sawcutting for New Utilities	Included	Included	Included	Included	Included	Included	
Excavation, compact bottom, sand shading, install pipe, backfill, compaction of trench	Included	Included	Included	Included	Included	Included	
Base Pave Trenches	Included	Included	Included	Included	Included	Included	
Overlay trench with new AC Paving section	Included	Included	Included	Included	Included	Included	
Lane Closure/Traffic Control	Included	Included	Included	Included	Included	Included	
Water Line for Irrigation inside the CIP Planters - L-1 (not clearly indicated on C sheets)	2,500	2,500	2,500	2,500	2,500	2,500	
Include tapping into existing mainline for new lines	Included	Included	Included	Included	Included	Included	
Sawcut & remove AC paving & put back for access to mainline tap-in	Included	Included	Included	Included	Included	Included	

Bid Evaluation Report



Site Utilities

Marshall Classroom Building

Subcontractors

Description	Subcontractors				Suttles Plumbing	Toro Ent.
	BSN Construction	J. Vega Engineering	HPS Mechanical	Sam Hill & Sons		
New mainlines & lateral lines for irrigation & rigid pvc for control wire	Included	Included	Included	Included	Included	
Other:						
FDC Bollards & Footings (include if not shown)	1,000	1,000	1,000	1,000	1,000	
POC Flanged into FS min 24" aff room by this sub - 1/FP-02	Included	Included	Included	Included	Included	
Gas						
NOT SHOWN on Site Utility Plan C-401,402,403,404	Included	Included	Included	Included	Included	
Gas Lines per Plumbing Sheets	Included	Included	Included	Included	Included	
Connect to existing Gas Line onsite - Not Shown	See Allowance	See Allowance	See Allowance	See Allowance	See Allowance	
TOTALS	228,861	325,112	212,022	210,055	256,632	0
Recommendation:	Amount					
Sam Hill & Sons	210,055					

OSD BOARD AGENDA ITEM

Name of Contributor: Dr. Anabolena DeGenna

Date of Meeting: 4/3/19

- Study Session: _____
Closed Session _____
- A-1. Preliminary _____
A-II. Reports _____
B. Hearings _____
C. Consent Agenda _____
- Agreement Category:
____ Academic
____ Enrichment
 Special Education
____ Support Services
____ Personnel
____ Legal
____ Facilities
- D. Action Items _____
F. Board Policies 1st Reading _____ 2nd Reading _____

Ratification of Amendment #1 to Agreement #18-175 – City Impact Inc. (DeGenna/Sugden)

At the Board Meeting of January 16, 2019, the Board of Trustees ratified Agreement #18-175, in the amount of \$90,000.00, with City Impact, Inc. to provide individual and/or group therapy services, and clinical supervision to the Special Education Services Department.

Amendment #1 is now required to add Social and Emotional Testing and Assessment Reporting services for the remainder of the fiscal year. The total amount of the agreement will remain the same.

FISCAL IMPACT:

None

RECOMMENDATION:

It is the recommendation of the Director, Special Education Services, and the Assistant Superintendent, Educational Services, that the Board of Trustees ratify Amendment #1 to Agreement #18-175 with City Impact Inc.

ADDITIONAL MATERIAL(S):

Attached: Amendment #1 (1 Page)
REVISED Scope of Work (1 Page)
Agreement #18-175, City Impact Inc. (19 Pages)

**AMENDMENT #1 TO AGREEMENT #18-175 with
City Impact, Inc.
April 3, 2019**

At the Board Meeting of January 16, 2019, the Board of Trustees ratified Agreement #18-175, in the amount of \$90,000.00, with City Impact, Inc. to provide individual and/or group therapy services, and clinical supervision to the Special Education Services Department.

Amendment #1 is now required to add Social and Emotional Testing and Assessment Reporting services for the remainder of the fiscal year. The total amount of the agreement will remain the same.

CITY IMPACT, INC.:

By: _____
Betty A. Ham, President

Date: _____

OXNARD SCHOOL DISTRICT:

By: _____
Lisa A. Franz, Director, Purchasing

Date: _____



SCOPE OF WORK

1. Provide Individual Therapy – in school (English or Spanish)
2. Provide Group Therapy Services – in School (English or Spanish)
3. Attendance at IEP (when requested by School Psychologist or District Administration)
4. Provide Individual Therapy Services – (in home or City Impact Office (English or Spanish)
5. Provide Social and Emotional Testing and Assessment Report

**COUNSELING SERVICES
RATE SHEET**

SERVICE	RATE PER HOUR
Individual Therapy (in school) English	\$61.81
Individual Therapy (in school) Spanish	\$71.96
Group Therapy (in school) English	\$82.42
Group Therapy (in school) Spanish	\$89.54
Attendance at an IEP (English)	\$61.81
Attendance at an IEP (Spanish)	\$71.96
Counseling (in home/City Impact office) English	\$82.42
Counseling (in home/City Impact office) Spanish	\$89.54
Social and Emotional Testing and Assessment Report	\$90.00

OXNARD SCHOOL DISTRICT

Agreement #18-175

AGREEMENT FOR CONSULTANT SERVICES

This Agreement for Consultant Services ("Agreement") is entered into as of this 16th day of January, 2019 by and between the Oxnard School District ("District") and City Impact Inc. ("Consultant"). District and Consultant are sometimes hereinafter individually referred to as "Party" and hereinafter collectively referred to as the "Parties."

RECITALS

- A. District is authorized by *California Government Code* Section 53060, and Board Policy 4368, to contract with independent contractors for the furnishing of services concerning financial, economic, accounting, engineering, legal, administrative and other matters. District has sought, by issuance of a Request for Proposals or Invitation for Bids, the performance of the Services, as defined and described particularly on Exhibit A, attached to this Agreement.
- B. Following submission of a proposal or bid for the performance of the Services, Consultant was selected by the District to perform the Services.
- C. The Parties desire to formalize the selection of Consultant for performance of the Services and desire that the terms of that performance be as particularly defined and described herein.

OPERATIVE PROVISIONS

NOW, THEREFORE, in consideration of the mutual promises and covenants made by the Parties and contained here and other consideration, the value and adequacy of which are hereby acknowledged, the parties agree as follows:

- Incorporation of Recitals and Exhibits.** The Recitals set forth above and all exhibits attached to this Agreement, as hereafter amended, are incorporated by this reference as if fully set forth herein.
- Term of Agreement.** Subject to earlier termination as provided below, this Agreement shall remain in effect from **January 7, 2019** through **June 30, 2020** (the "Term"). This Agreement may be extended only by amendment, signed by the Parties, prior to the expiration of the Term.
- Time for Performance.** The scope of services set forth in Exhibit A shall be completed during the Term pursuant to the schedule specified Exhibit A. Should the scope of services not be completed pursuant to that schedule, the Consultant shall be deemed to be in Default as provided below. The District, in its sole discretion, may choose not to enforce the Default provisions of this Agreement and may instead allow Consultant to continue performing the Services.
- Compensation and Method of Payment.** Subject to any limitations set forth below or elsewhere in this Agreement, District agrees to pay Consultant the amounts specified in Exhibit B "Compensation". The total compensation, including reimbursement for actual expenses, shall not exceed Ninety Thousand Dollars (\$90,000.00), per attached Rate Sheets, unless additional compensation is approved in writing by the District.

- a. Each month Consultant shall furnish to District an original invoice for all work performed and expenses incurred during the preceding month. The invoice shall detail charges by the following categories: labor (by sub-category), travel, materials, equipment, supplies, and sub-consultant contracts. Sub-consultant charges, if any, shall be detailed by the following categories: labor, travel, materials, equipment and supplies. District shall independently review each invoice submitted by the Consultant to determine whether the work performed and expenses incurred are in compliance with the provisions of this Agreement. In the event that no charges or expenses are disputed, the invoice shall be approved and paid according to the terms set forth in subsection b. In the event any charges or expenses are disputed by District, the original invoice shall be returned by District to Consultant for correction and resubmission.
- b. Except as to any charges for work performed or expenses incurred by Consultant which are disputed by District, District will use its best efforts to cause Consultant to be paid within forty-five (45) days of receipt of Consultant's correct and undisputed invoice.
- c. Payment to Consultant for work performed pursuant to this Agreement shall not be deemed to waive any defects in work performed by Consultant.

5. **Termination.** This Agreement may be terminated at any time by mutual agreement of the Parties or by either Party as follows:

- a. District may terminate this Agreement, with or without cause, at any time by giving thirty (30) days written notice of termination to Consultant. In the event such notice is given, Consultant shall cease immediately all work in progress; or
- b. Consultant may terminate this Agreement for cause at any time upon thirty (30) days written notice of termination to District.

6. **Inspection and Final Acceptance.** District may, at its discretion, inspect and accept or reject any of Consultant's work under this Agreement, either during performance or when within sixty (60) days after submitted to District. If District does not reject work by a timely written explanation, Consultant's work shall be deemed to have been accepted. District's acceptance shall be conclusive as to such work except with respect to latent defects, fraud and such gross mistakes as amount to fraud. Acceptance of any of Consultant's work by District shall not constitute a waiver of any of the provisions of this Agreement including, but not limited to indemnification and insurance provisions.

7. **Default.** Failure of Consultant to perform any Services or comply with any provisions of this Agreement may constitute a default. The District may give notice to Consultant of the default and the reasons for the default. District shall not have any obligation or duty to continue compensating Consultant for any work performed after the date of the notice until the default is cured. The notice shall include the timeframe in which Consultant may cure the default. This timeframe is presumptively thirty (30) days, but may be extended, though not reduced, at the discretion of the District. During the period of time that Consultant is in default, the District shall hold all invoices and shall, when the default is cured, proceed with payment on the invoices. In the alternative, the District may, in its sole discretion, elect to pay some or all of the outstanding invoices during the period of default. If Consultant does not cure the default, the District may terminate this Agreement as provided above. Any failure on the part of the District to give notice of the Consultant's default shall not be deemed to result in a waiver of the District's legal rights or any rights arising out of any provision of this Agreement.

8. **Ownership of Documents.** All maps, models, designs, drawings, photographs, studies, surveys, reports, data, notes, computer files, files and other documents prepared, developed or discovered by Consultant in the course of providing any services pursuant to this Agreement (collectively and individually, the "Documents") shall

become the sole property of District and may be used, reused or otherwise disposed of by District without the permission of the Consultant. Upon completion, expiration or termination of this Agreement, Consultant shall turn over to District all such Documents.

9. **Use of Documents by District.** If and to the extent that District utilizes for any purpose not related to this Agreement any Documents, Consultant's guarantees and warrants related to Standard of Performance under this Agreement shall not extend to such use of the Documents.

10. **Consultant's Books and Records.** Consultant shall maintain any and all documents and records demonstrating or relating to Consultant's performance of services pursuant to this Agreement for a minimum of three years after termination or expiration of this Agreement, or longer if required by law.

- a. Consultant shall maintain any and all ledgers, books of account, invoices, vouchers, canceled checks, or other documents or records evidencing or relating to work, services, expenditures and disbursements charged to District pursuant to this Agreement for a minimum of three years, or longer if required by law, all in accordance with generally accepted accounting principles and with sufficient detail so as to permit an accurate evaluation of the services provided by Consultant pursuant to this Agreement.
- b. Any and all such records or documents shall be made available for inspection, audit and copying, at any time during regular business hours, upon request by District or its designated representative. Copies of such documents or records shall be provided directly to the District for inspection, audit and copying when it is practical to do so; otherwise, unless an alternative is mutually agreed upon, such documents and records shall be made available at Consultant's address indicated for receipt of notices in this Agreement.
- c. District has the right to acquire custody of such records by written request if Consultant decides to dissolve or terminate its business. Consultant shall deliver or cause to be delivered all such records and documents to District within sixty (60) days of receipt of the request.

11. **Independent Contractor.** Consultant is and shall at all times remain a wholly independent contractor and not an officer, employee or agent of District.

- a. The personnel performing the services under this Agreement on behalf of Consultant shall at all times be under Consultant's exclusive direction and control. Consultant, its agents or employees shall not at any time or in any manner represent that Consultant or any of Consultant's officers, employees, or agents are in any manner officials, officers, employees or agents of District. Neither Consultant, nor any of Consultant's officers, employees or agents, shall, by virtue of services rendered under this Agreement, obtain any rights to retirement, health care or any other benefits which may otherwise accrue to District's employees. Consultant will be responsible for payment of all Consultant's employees' wages, payroll taxes, employee benefits and any amounts due for federal and state income taxes and Social Security taxes since these taxes will not be withheld from payment under this agreement.
- b. Consultant shall have no authority to bind District in any manner, or to incur any obligation, debt or liability of any kind on behalf of or against District, whether by contract or otherwise, unless such authority is expressly conferred in writing by District, or under this Agreement.

12. **Standard of Performance.** Consultant represents and warrants that it has the qualifications, experience and facilities necessary to properly perform the services required under this Agreement in a thorough, competent and professional manner. Consultant shall at all times faithfully, competently and to the best of its ability, experience and talent, perform all services described herein. In meeting its obligations under this Agreement,

Consultant shall employ, at a minimum, generally accepted standards and practices utilized by persons engaged in providing services similar to those required of Consultant under this Agreement.

13. **Confidential Information.** All information gained during performance of the Services and all Documents or other work product produced by Consultant in performance of this Agreement shall be considered confidential. Consultant shall not release or disclose any such information, Documents or work product to persons or entities other than District without prior written authorization from the Superintendent of the District, except as may be required by law.

- a. Consultant shall promptly notify District if it is served with any summons, complaint, subpoena or other discovery request, court order or other request from any party regarding this Agreement or the work performed hereunder.
- b. District retains the right, but has no obligation, to represent Consultant or be present at any deposition, hearing or similar proceeding. Consultant agrees to cooperate fully with District and to provide District with the opportunity to review any response to discovery requests provided by Consultant; provided that this does not imply or mean the right by District to control, direct, or rewrite said response.

14. **Conflict of Interest; Disclosure of Interest.** Consultant covenants that neither it, nor any officer or principal of its firm, has or shall acquire any interest, directly or indirectly, which would conflict in any manner with the interests of District or which would in any way hinder Consultant's performance of services under this Agreement. Consultant further covenants that in the performance of this Agreement, no person having any such interest shall be employed by it as an officer, employee, agent or subcontractor without the express written consent of the District.

- a. Consultant agrees to at all times avoid conflicts of interest or the appearance of any conflicts of interest with the interests of District in the performance of this Agreement.
- b. Bylaws of the Board 9270 BB and 9270(BB) E, as hereinafter amended or renumbered, require that a Consultant that qualifies as a "designated employee" must disclose certain financial interests by filing financial interest disclosures. By its initials below, Consultant represents that it has received and reviewed a copy of the Bylaws of the Board 9270 BB and 9270(BB) E and that it does does not qualify as a "designated employee".

BAH (Initials)

- c. Consultant agrees to notify the Superintendent, in writing, if Consultant believes that it is a "designate employee" and should be filing financial interest disclosures, but has not been required to do so by the District.

BAH (Initials)

15. **Compliance with Applicable Laws.** In connection with the Services and its operations, Consultant shall keep itself informed of and comply with all applicable federal, state and local laws, statutes, codes, ordinances, regulations and rules including, but not limited to, minimum wages and/or prohibitions against discrimination, in effect during the Term. Consultant shall obtain any and all licenses, permits and authorizations necessary to perform the Services. Neither District, nor any elected or appointed boards, officers, officials, employees or agents of District shall be liable, at law or in equity, as a result of any failure of Consultant to comply with this section.

- a. Without limiting the generality of the foregoing, Consultant shall comply with any applicable fingerprinting requirements as set forth in the Education Code of the State of California.

BAH (Initials)

16. **Unauthorized Aliens.** Consultant hereby promises and agrees to comply with all of the provisions of the Federal Immigration and Nationality Act, 8 U.S.C.A. §§ 1101, et seq., as amended, and in connection therewith, shall not employ "unauthorized aliens" as that term is defined in 8 U.S.C.A. §1324a(h)(3). Should Consultant so employ such individuals for the performance of work and/or services covered by this Agreement, and should any liability or sanctions be imposed against District for such employment, Consultant hereby agrees to and shall reimburse District for the cost of all such liabilities or sanctions imposed, together with any and all costs, including attorneys' fees, incurred by District.

17. **Non-Discrimination.** Consultant shall abide by the applicable provisions of the United States Civil Rights Act of 1964 and other provisions of law prohibiting discrimination and shall not discriminate, in any way, against any person on the basis of race, color, religious creed, national origin, ancestry, sex, age, physical handicap, medical condition or marital status in connection with or related to the performance of this Agreement.

18. **Assignment.** The expertise and experience of Consultant are material considerations for this Agreement. District has an interest in the qualifications of and capability of the persons and entities that will fulfill the duties and obligations imposed upon Consultant under this Agreement. In recognition of that interest, Consultant shall not assign or transfer this Agreement or any portion of this Agreement or the performance of any of Consultant's duties or obligations under this Agreement without the prior written consent of the Board of Directors of the District. Any attempted assignment shall be ineffective, null and void, and shall constitute a material breach of this Agreement entitling District to any and all remedies at law or in equity, including summary termination of this Agreement.

19. **Subcontracting.** Notwithstanding the above, Consultant may utilize subcontractors in the performance of its duties pursuant to this Agreement, but only with the prior written consent of the District. The Consultant shall be as fully responsible to the District for the acts and omissions of his Subcontractors, and of persons either directly or indirectly employed by him/her, as if the acts and omissions were performed by him/her directly.

20. **Continuity of Personnel.** Consultant shall make every reasonable effort to maintain the stability and continuity of Consultant's staff and subcontractors, if any, assigned to perform the services required under this Agreement.

- a. Consultant shall insure that District has a current list of all personnel and sub-contractors providing services under this Agreement.
- b. Consultant shall notify District of any changes in Consultant's staff and subcontractors, if any, assigned to perform the services required under this Agreement, prior to and during any such performance. The list notice shall include the following information: (1) all full or part-time staff positions by title, including volunteer positions whose direct services are required to provide the services described herein; (2) a brief description of the functions of each such position and the hours each position works each week or, for part-time positions, each day or month, as appropriate; (3) the professional degree, if applicable, and experience required for each position; and (4) the name of the person responsible for fulfilling the terms of this Agreement.

21. **Indemnification.**

- a. Consultant agrees to defend, indemnify, and hold harmless District, its officers, agents, employees, and/or volunteers from any and all claims, demands, losses, damages and expenses, including legal fees and costs, or other obligations or claims arising out of any liability or damage to property, or any other loss, sustained or claimed to have been sustained arising out of activities of the Consultant or those of any of Consultant's officers, agents, employees, or subcontractors, whether such act or omission is authorized by this Agreement or not. Consultant shall also pay for any and all damage to the Property of the District, or loss or theft of such Property, done or caused by such persons. District

assumes no responsibility whatsoever for any property placed on district premises. Consultant further agrees to waive all rights of subrogation against the District. The provisions of this Agreement do not apply to any damage or losses caused solely by the negligence of the District or any of its officers, agents, employees, and/or volunteers.

BJ (Initials)

- b. The provisions of this section do not apply to claims occurring as a result of District's sole negligence or willful acts or omissions.

22. **Insurance.** Consultant agrees to obtain and maintain in full force and effect during the term of this Agreement the insurance policies set forth in Exhibit C "Insurance" and made a part of this Agreement. All insurance policies shall be subject to approval by District as to form and content. These requirements are subject to amendment or waiver if so approved in writing by the District Superintendent. Consultant agrees to provide District with copies of required policies upon request.

23. **Notices.** All notices required or permitted to be given under this Agreement shall be in writing and shall be personally delivered, or sent by telecopier or certified mail, postage prepaid and return receipt requested, addressed as follows:

To District: Oxnard School District
1051 South A Street
Oxnard, California, 93030
Attention: Amelia Sugden
Phone: (805) 385.1501 x2175
Fax: (805) 487.9648

To Consultant: City Impact Inc.
555 South A Street, Suite 185
Oxnard, CA 93030
Attn: Betty Alvarez Ham
Phone: (805) 983.3636
Fax: (805) 983.3636

Notice shall be deemed effective on the date personally delivered or transmitted by facsimile (provided confirmation of successful facsimile transmission shall be retained) or, if mailed, three (3) days after deposit of the same in the custody of the United States Postal Service.

24. **Excusable Delays.** Consultant shall not be liable for damages, including liquidated damages, if any, caused by delay in performance or failure to perform due to causes beyond the control of Consultant. Such causes include, but are not limited to, acts of God, acts of the public enemy, acts of federal, state or local governments, acts of District, court orders, fires, floods, epidemics, strikes, embargoes, and unusually severe weather. The term and price of this Agreement shall be equitably adjusted for any delays due to such causes.

25. **Authority to Execute.** The person or persons executing this Agreement on behalf of Consultant represents and warrants that he/she/they has/have the authority to so execute this Agreement and to bind Consultant to the performance of its obligations hereunder.

26. **Administration.** AMELIA SUGDEN shall be in charge of administering this Agreement on behalf of the District. The Director of Purchasing has completed Exhibit D "Conflict of Interest Check" attached hereto.

27. **Binding Effect.** This Agreement shall be binding upon the heirs, executors, administrators, successors and assigns of the parties.

28. **Entire Agreement.** This Agreement and the exhibits and documents incorporated herein constitute the entire agreement and understanding between the parties in connection with the matters covered herein.

29. **Amendment.** No amendment to or modification of this Agreement shall be valid or binding unless made in writing by the Consultant and by the District. The parties agree that this requirement for written modifications cannot be waived and that any attempted waiver shall be void.

30. **Waiver.** Waiver by any party to this Agreement of any term, condition, or covenant of this Agreement shall not constitute a waiver of any other term, condition, or covenant. Waiver by any party of any breach of the provisions of this Agreement shall not constitute a waiver of any other provision or a waiver of any subsequent breach or violation of any provision of this Agreement. Acceptance by District of any work or services by Consultant shall not constitute a waiver of any of the provisions of this Agreement.

31. **Governing Law.** This Agreement shall be interpreted, construed and governed according to the laws of the State of California. In the event of litigation between the parties, venue in state trial courts shall lie exclusively in the County of Ventura, California.

32. **Arbitration.** Any dispute arising out of the performance of this Agreement shall be resolved by binding arbitration in accordance with rules and procedures of the American Arbitration Association.

33. **Severability.** If any term, condition or covenant of this Agreement is declared or determined by any court of competent jurisdiction to be invalid, void or unenforceable, the remaining provisions of this Agreement shall not be affected thereby and the Agreement shall be read and construed without the invalid, void or unenforceable provision(s).

[THE REMAINDER OF THIS PAGE IS INTENTIONALLY LEFT BLANK]

IN WITNESS WHEREOF, the District and Consultant have executed and delivered this agreement for consultant services as of the date first written above.

OXNARD SCHOOL DISTRICT:

Lisa A. Franz

Signature

Lisa A. Franz, Director, Purchasing
Typed Name/Title

1-24-19

Date

Tax Identification Number: 95-6002318

CITY IMPACT INC.:

Benny Alvarez

Signature

Benny Alvarez Ham, President
Typed Name/Title

1/22/19

Date

Tax Identification Number: 77-0388915

- Not Project Related
- Project #18-175

EXHIBIT A
TO AGREEMENT FOR CONSULTANT SERVICES #18-175

SERVICES

I. Consultant will perform the following Services under the Captioned Agreement:

*Provide Individual Student and/or Group Therapy, as well as Staff Supervision for the Special Education Services Department during the 2018-2019 & 2019-2020 school years, per attached Rate Sheets.

II. As part of the Services, Consultant will prepare and deliver the following tangible work products to the District:

III. During performance of the Services, Consultant will keep the District apprised of the status of performance by delivering the following status reports under the indicated schedule:

STATUS REPORT FOR ACTIVITY:	DUE DATE
A. N/A	
B.	
C.	
D.	

V. Consultant will utilize the following personnel to accomplish the Services:

- None.
- See attached list.

VI. Consultant will utilize the following subcontractors to accomplish the Services (check one):

- None.
- See attached list.

VII. AMENDMENT

The Scope of Services, including services, work product, and personnel, are subject to change by mutual Agreement. In the absence of mutual Agreement regarding the need to change any aspects of performance, Consultant shall comply with the Scope of Services as indicated above

Not Project Related

Project #18-175

EXHIBIT B
TO AGREEMENT FOR CONSULTANT SERVICES #18-175

COMPENSATION

I. Consultant shall use the following rates of pay in the performance of the Services:

**TOTAL FEE NOT TO EXCEED \$90,000.00 per attached Rate Sheets

II. Consultant may utilize subcontractors as indicated in this Agreement. The hourly rate for any subcontractor is not to exceed \$ N/A per hour without written authorization from the District Superintendent or his designee.

III. The District will compensate Consultant for the Services performed upon submission of a valid invoice. Each invoice is to include:

- A. Line items for all personnel describing the work performed, the number of hours worked, and the Hourly or flat rate.
- B. Line items for all supplies properly charged to the Services.
- C. Line items for all travel properly charged to the Services.
- D. Line items for all equipment properly charged to the Services.
- E. Line items for all materials properly charged to the Services.
- F. Line items for all subcontractor labor, supplies, equipment, materials, and travel properly charged to the Services.

IV. The total compensation for the Services shall not exceed \$90,000.00, per attached Rate Sheets, as provided in Section 4 of this Agreement.

Not Project Related

Project #18-175

EXHIBIT C
TO AGREEMENT FOR CONSULTANT SERVICES #18-175

INSURANCE

I. Insurance Requirements. Consultant shall provide and maintain insurance, acceptable to the District Superintendent or District Counsel, in full force and effect throughout the term of this Agreement, against claims for injuries to persons or damages to property which may arise from or in connection with the performance of the work hereunder by Consultant, its agents, representatives or employees. Insurance is to be placed with insurers authorized to conduct business in the State of California and with a current A.M. Best's rating of no less than A, as rated by the Current edition of Best's Key Rating Guide, published by A.M. Best Company, Oldwick, New Jersey 08858. Consultant shall provide the following scope and limits of insurance:

A. Minimum Scope of Insurance. Coverage shall be at least as broad as:

(1) Commercial General Liability coverage of not less than two million dollars (\$2,000,000) Aggregate and one million dollars (\$1,000,000) per occurrence.

(2) Auto liability insurance with limits of not less than one million dollars (\$1,000,000).

(3) Insurance coverage should include:

1. owned, non-owned and hired vehicles;
2. blanket contractual;
3. broad form property damage;
4. products/completed operations; and
5. personal injury.

(4) Workers' Compensation insurance as required by the laws of the State of California.

(5) Abuse and Molestation coverage of not less than two million dollars (\$2,000,000) per occurrence and five million dollars (\$5,000,000) Aggregate.

(6) Professional liability (Errors and Omissions) insurance, including contractual liability, as appropriate to the Consultant's profession, in an amount of not less than the following:

Accountants, Attorneys, Education Consultants, Nurses, Therapists	\$1,000,000
Architects	\$1,000,000 or \$2,000,000
Physicians and Medical Corporations	\$5,000,000

Failure to maintain professional liability insurance is a material breach of this Agreement and grounds for immediate termination

II. Other Provisions. Insurance policies required by this Agreement shall contain the following provisions:

Not Project Related

Project #18-175

A. All Policies. Each insurance policy required by this Agreement shall be endorsed and state the coverage shall not be suspended, voided, cancelled by the insurer or either party to this Agreement, reduced in coverage or in limits except after 30 days' prior written notice by Certified mail, return receipt requested, has been given to District

B. General Liability, Automobile Liability, and Abuse/Molestation Coverages.

(1) District, and its respective elected and appointed officers, officials, employees and volunteers are to be covered as additional insureds (collectively, "additional insureds") as respects the following: liability arising out of activities Consultant performs; products and completed operations of Consultant; premises owned, occupied or used by Consultant ; automobiles owned, leased, hired or borrowed by Consultant, and Abuse/Molestation. The coverage shall contain no special limitations on the scope of protection afforded to additional insureds.

(2) Each policy shall state that the coverage provided is primary and any insurance carried by any additional insured is in excess to and non-contributory with Consultant's insurance.

(3) Consultant's insurance shall apply separately to each insured against whom claim is made or suit is brought, except with respect to the limits of the insurer's liability.

(4) Any failure to comply with the reporting or other provisions of the policies including breaches of warranties shall not affect coverage provided to any additional insured.

III. Other Requirements. Consultant agrees to deposit with District, at or before the effective date of this contract, certificates of insurance necessary to satisfy District that the insurance provisions of this contract have been complied with. The District may require that Consultant furnish District with copies of original endorsements effecting coverage required by this Section. The certificates and endorsements are to be signed by a person authorized by that insurer to bind coverage on its behalf. District reserves the right to inspect complete, certified copies of all required insurance policies, at any time.

A. If any Services are performed by subcontractor, Consultant shall furnish certificates and endorsements from each subcontractor identical to those Consultant provides.

B. Any deductibles or self-insured retentions must be declared to and approved by District. At the option of District, either the insurer shall reduce or eliminate such deductibles or self-insured retentions as respects District or its respective elected or appointed officers, officials, employees and volunteers or the Consultant shall procure a bond guaranteeing payment of losses and related investigations, claim administration, defense expenses and claims.

C. The procuring of any required policy or policies of insurance shall not be construed to limit Consultant's liability hereunder nor to fulfill the indemnification provisions and requirements of this Agreement.

- Not Project Related
- Project #18-175

EXHIBIT D
TO AGREEMENT FOR CONSULTANT SERVICES #18-175

CONFLICT OF INTEREST CHECK

Bylaws of the Board 9270(BB)E requires that the Superintendent or a designee make a determination, on a case by case basis, concerning whether disclosure will be required from a consultant to comply with the District's Conflict of Interest Code (commencing with Bylaws of the Board 9270 BB).

Consultant's are required to file disclosures when, pursuant to a contract with the District, the Consultant will make certain specified government decisions or will perform the same or substantially the same duties for the District as a staff person would.

The services to be performed by Consultant under the Agreement to which this Exhibit D is attached constitute do not constitute governmental decisions or staff services within the meaning of the Conflict of Interest Code. Therefore, the Consultant, CITY IMPACT INC., who will provide Services under the Agreement, is is not subject to disclosure obligations.

Date: 1-24-19

By: L. Franz

Lisa A. Franz
Director, Purchasing



SCOPE OF WORK

1. Provide Individual Therapy – in school (English or Spanish)
2. Provide Group Therapy Services – in School (English or Spanish)
3. Attendance at IEP (when requested by School Psychologist or District Administration)
4. Provide Individual Therapy Services – (in home or City Impact Office (English or Spanish)

**COUNSELING SERVICES
RATE SHEET**

SERVICE	RATE PER HOUR
Individual Therapy (in school) English	\$61.81
Individual Therapy (in school) Spanish	\$71.96
Group Therapy (in school) English	\$82.42
Group Therapy (in school) Spanish	\$89.54
Attendance at an IEP (English)	\$61.81
Attendance at an IEP (Spanish)	\$71.96
Counseling (in home/City Impact office) English	\$82.42
Counseling (in home/City Impact office) Spanish	\$89.54



SCOPE OF WORK

Provide Clinical Supervision for School Psychologist acquiring MFT hours. City Impact's Clinical Supervisor is a Licensed Social Worker #14219 and is covered under California Board of Behavioral Science Examiners.

1. Clinical Supervision (Group – 2 hour)
2. Clinical Supervision (Individual – 1 hour)

Clinical Supervision (Group) (2 hour)	\$65.00 per hour
Clinical Supervision (Individual)	\$70.00

THIS ENDORSEMENT CHANGES THE POLICY. PLEASE READ IT CAREFULLY.

ADDITIONAL INSURED – OWNERS, LESSEES OR CONTRACTORS – SCHEDULED PERSON OR ORGANIZATION

This endorsement modifies insurance provided under the following:

COMMERCIAL GENERAL LIABILITY COVERAGE PART

SCHEDULE

Name Of Additional Insured Person(s) Or Organization(s)	Location(s) Of Covered Operations
Any person or organization that you are required to add as an additional insured on this policy, under a written contract or agreement currently in effect, or becoming effective during the term of this policy. The additional insured status will not be afforded with respect to liability arising out of or related to your activities as a real estate manager for that person or organization.	All insured premises and operations.
Information required to complete this Schedule, if not shown above, will be shown in the Declarations.	

A. Section II – Who Is An Insured is amended to include as an additional insured the person(s) or organization(s) shown in the Schedule, but only with respect to liability for "bodily injury", "property damage" or "personal and advertising injury" caused, in whole or in part, by:

1. Your acts or omissions; or
2. The acts or omissions of those acting on your behalf;

in the performance of your ongoing operations for the additional insured(s) at the location(s) designated above.

However:

1. The insurance afforded to such additional insured only applies to the extent permitted by law; and

2. If coverage provided to the additional insured is required by a contract or agreement, the insurance afforded to such additional insured will not be broader than that which you are required by the contract or agreement to provide for such additional insured.

B. With respect to the insurance afforded to these additional insureds, the following additional exclusions apply:

This insurance does not apply to "bodily injury" or "property damage" occurring after:

1. All work, including materials, parts or equipment furnished in connection with such work, on the project (other than service, maintenance or repairs) to be performed by or on behalf of the additional insured(s) at the location of the covered operations has been completed; or

2. That portion of "your work" out of which the injury or damage arises has been put to its intended use by any person or organization other than another contractor or subcontractor engaged in performing operations for a principal as a part of the same project.

- C. With respect to the insurance afforded to these additional insureds, the following is added to **Section III – Limits Of Insurance:**

If coverage provided to the additional insured is required by a contract or agreement, the most we will pay on behalf of the additional insured is the amount of insurance:

1. Required by the contract or agreement; or

2. Available under the applicable Limits of Insurance shown in the Declarations; whichever is less.

This endorsement shall not increase the applicable Limits of Insurance shown in the Declarations.

THIS ENDORSEMENT CHANGES THE POLICY. PLEASE READ IT CAREFULLY.
**ADDITIONAL INSURED – OWNERS, LESSEES OR
 CONTRACTORS – COMPLETED OPERATIONS**

This endorsement modifies insurance provided under the following:

COMMERCIAL GENERAL LIABILITY COVERAGE PART
 PRODUCTS/COMPLETED OPERATIONS LIABILITY COVERAGE PART

SCHEDULE

Name Of Additional Insured Person(s) Or Organization(s)	Location And Description Of Completed Operations
Any person or organization that you are required to add as an additional insured on this policy, under a written contract or agreement currently in effect, or becoming effective during the term of this policy. The additional insured status will not be afforded with respect to liability arising out of or related to your activities as a real estate manager for that person or organization.	All insured premises and operations.
Information required to complete this Schedule, if not shown above, will be shown in the Declarations.	

A. Section II – Who Is An Insured is amended to include as an additional insured the person(s) or organization(s) shown in the Schedule, but only with respect to liability for "bodily injury" or "property damage" caused, in whole or in part, by "your work" at the location designated and described in the Schedule of this endorsement performed for that additional insured and included in the "products-completed operations hazard".

However:

1. The insurance afforded to such additional insured only applies to the extent permitted by law; and
2. If coverage provided to the additional insured is required by a contract or agreement, the insurance afforded to such additional insured will not be broader than that which you are required by the contract or agreement to provide for such additional insured.

B. With respect to the insurance afforded to these additional insureds, the following is added to **Section III – Limits Of Insurance:**

If coverage provided to the additional insured is required by a contract or agreement, the most we will pay on behalf of the additional insured is the amount of insurance:

1. Required by the contract or agreement; or
2. Available under the applicable Limits of Insurance shown in the Declarations; whichever is less.

This endorsement shall not increase the applicable Limits of Insurance shown in the Declarations.

OSD BOARD AGENDA ITEM

Name of Contributor: Dr. Anabolena DeGenna

Date of Meeting: 4/3/19

- Study Session:** _____
Closed Session _____
- A-1. Preliminary** _____
A-II. Reports _____
B. Hearings _____
C. Consent Agenda _____
- Agreement Category:**
____ Academic
____ Enrichment
X Special Education
____ Support Services
____ Personnel
____ Legal
____ Facilities
- D. Action Items** _____
F. Board Policies 1st Reading _____ 2nd Reading _____

Ratification of Amendment #1 to Agreement/MOU #18-44 – Tutorific! (DeGenna/Sugden)

At the Board Meeting of August 8, 2018, the Board of Trustees ratified Agreement #18-44, in the amount of \$38,000.00, with Tutorific! to provide additional instruction to students selected or assigned by the Special Education Services Department for tutoring outside of the normal school day during the 2018-2019 academic year.

Amendment #1 in the amount of \$33,000.00 will allow the Special Education Services Department to increase the number of students receiving instruction support through the remainder of the fiscal year, for a new total agreement amount of \$71,000.00.

FISCAL IMPACT:

\$33,000.00 (billed at \$60.00 per hour) – Special Education Funds

RECOMMENDATION:

It is the recommendation of the Assistant Superintendent, Educational Services, and the Director, Special Education Services, that the Board of Trustees ratify Amendment #1 to Agreement/MOU #18-44 with Tutorific!.

ADDITIONAL MATERIAL(S):

Attached: Amendment #1 (1 Page)
Agreement/MOU #18-44, Tutorific! (6 Pages)

**AMENDMENT #1 TO AGREEMENT #18-44 with
Tutorific!
April 3, 2019**

At the Board Meeting of August 8, 2018, the Board of Trustees ratified Agreement #18-44, in the amount of \$38,000.00, with Tutorific! to provide additional instruction to students selected or assigned by the Special Education Services Department for tutoring outside of the normal school day during the 2018-2019 academic year.

Amendment #1 in the amount of \$33,000.00 will allow the Special Education Services Department to increase the number of students receiving instruction support through the remainder of the fiscal year, for a new total agreement amount of \$71,000.00.

TUTORIFIC!:

By: _____
Matt Oppenheimer, Owner

Date: _____

OXNARD SCHOOL DISTRICT:

By: _____
Lisa A. Franz, Director of Purchasing

Date: _____



Memorandum of Understanding (“MOU”) #18-44
Between
Oxnard School District (“OSD”) Special Education Department
1051 South “A” Street, Oxnard, CA 93030
And TUTORIFIC! (“Tutorific”)



- 1. Purpose.** This MOU is entered into for the purpose of providing additional instruction to students selected or assigned by OSD for tutoring outside of the normal school day (“Student”).
- 2. Term.** The Term of this Contract begins on July 1, 2018 and ends on June 30, 2019 (“Term”).

Payment. Upon proper monthly invoicing which includes the amount of hours provided per student, District agrees to pay Tutorific for services performed during the Term of this Agreement at the rate of \$60 per hour per student for one-to-one tutoring.
- 3. Students.** Selection of students to participate under this MOU shall be at the discretion of OSD. Tutorific may decline and/or drop a Student if it is not possible to provide the tutoring due to lack of reasonable parent support in facilitating the tutoring (including but not limited to parent inflexibility to accept any of multiple scheduling options) or if the Student presents a danger to Tutorific staff. For each Student assigned to Tutorific by OSD, OSD shall provide Tutorific with the child’s name, parent(s) name(s), address, contact numbers, and any information OSD deems helpful in providing service to the Student, including but not limited to 504 plan, IEP, ISP, special education information, level of English language ability and home language, type of tutoring (if limited by OSD), and number of hours of tutoring (if limited by OSD).
- 4. Subjects & Duration.** The subject(s) to be tested and tutored and are pre-approved by OSD are reading, language arts, spelling, and math. If requested by the District and/or parent, and Tutorific’s tutor is able, tutor may assist with other subjects as best serves each student. Tutorific shall be notified by OSD in writing of Students assigned for a finite number of hours of tutoring at the time each Student is assigned, and OSD shall not be responsible to pay Tutorific for any tutoring beyond those stated hours. Students assigned without a finite number of hours shall be considered to be ongoing and OSD shall pay for all Tutorific-provided sessions for such Students throughout the school year in which the Students are assigned but OSD may stop any Student’s tutoring with a simple two week written notice.
- 5. Testing & Reporting.** Tutorific shall assess each Student as the first step of tutoring. Assessment time shall be counted and paid as tutoring time. Progress assessing and reporting shall occur approximately quarterly and at the end of each student’s assign duration with Tutorific. Progress is not tested nor reported for students who drop from the program before each scheduled progress test. Tutorific shall report non-excused absences to the district within a week of the missed session or missed make-up, whichever comes last. Attendance shall also be reported at the time of monthly billing.
- 6. Parent Communication.** Tutorific shall be responsible for parent communication related to student scheduling, absences, and make-ups. A copy of each report shall be provided by Tutorific to each Student’s parent. Tutorific shall provide reports to parents in Spanish when necessary for good communication.
- 7. Location of Tutoring.** The location of tutoring shall be determined by mutual agreement between Tutorific and the Student’s parent and may be at the school, Tutorific’s clinic, a public library, or in-home. Tutorific shall make good effort to provide the tutoring at each Student’s home school campus when possible while keeping in mind some families’ limitations related to parent work schedules and transportation, facility space and tutor availability.

8. Staff Qualifications. Provider will ensure that all individuals employed, contracted, or otherwise hired by Provider to provide instruction or related services are qualified in the area in which the individuals are providing such instruction or services. Provider will comply with all laws and regulations governing the licensed professions, including but not limited to, the provisions with respect to supervision. Provider will deliver designated instruction and services utilizing personnel who have experience working with the type(s) of student(s) assigned or who possess a license issued by an appropriate licensing agency authorizing the licensee to provide the specific service, or possess a credential authorizing the service or are otherwise qualified to provide the service. Tutorific may make exceptions to these qualification with the written approval of the Learning Rights Law Center or a representative of the Oxnard School District.

9. Materials. Tutorific shall supply Students with all materials necessary for providing high quality tutoring. Computer tablets and other electronic devices are not included as part of this MOU except those provided by OSD.

10. Independent Contractor. Nothing in this MOU will be construed to imply a joint venture or employment.

11. Student Confidentiality. Student information shall be kept confidential by Tutorific. A copy of all student records will be delivered to OSD with the monthly invoice. Records will be kept in accordance with the directed needs of OSD.

12. Incident, Accident, and Child Abuse Reporting. Tutorific will submit a written accident report to the District within 24 hours of any accident or incident when a pupil has suffered an injury, injured another individual, or has been involved in an activity requiring notification of law enforcement or emergency personnel. Tutorific hereby agrees that all staff members, including volunteers, are familiar with and agree to child abuse and missing children reporting obligations and procedures under California law, including but not limited to, California Education Code Section 49370 and California Penal Code section 11166, *et seq.* Tutorific agrees that all staff members will abide by such laws in a timely manner.

13. Insurance. Provider agrees to obtain and maintain in full force and effect during the term of this Contract the insurance policies set forth in **Exhibit A** "Insurance" and made a part of this Contract. All insurance policies shall be subject to approval by District as to form and content. These requirements are subject to amendment or waiver if so approved in writing by the District Superintendent. Provider agrees to provide District with copies of required policies upon request.

14. Discrimination. Provider shall not discriminate on the basis of race, religion, sex, national origin, age, disability or sexual orientation in employment or operation of its program.

15. References to OSD & Tutorific. All references to OSD and Tutorific in this agreement relate specifically to this MOU and not to any other agreement between OSD and Tutorific.

16. Termination.

a. Without Cause. This Contract may be terminated by the District or the Provider at any time. To terminate this Contract, either party will give 20 calendar days written notice prior to the date of termination. Upon termination, without default of Provider, the District will pay, without duplication, for all services satisfactorily performed to the date of termination. In consideration of this payment, Provider waives all rights to any further payment of damage. Under no circumstances will Provider be entitled to anticipatory, lost profits or consequential damages as a result of termination under this section.

b. For Cause.

(i) The District may, by written notice to the Provider, terminate this Contract in whole or in part at any time because of the failure of the Provider to fulfill its contractual obligations and the District may, in its sole discretion, provide Provider with a reasonable period within which to cure the default. Upon receipt of such notice, the Provider will (A) immediately discontinue all services affected (unless the notice directs otherwise) and (B) deliver to the District all information and material as may have been involved in the provision of services whether provided by the District or generated by the Provider in the performance of this Contract, whether completed or in process (unless the notice directs otherwise). Termination of this Contract will be as of the date of receipt by the Provider of such notice.

(ii) If the termination is due to the failure of the Provider to fulfill its contractual obligations, the District may take over the services and complete the services by contract or otherwise. Provider will be liable for the reasonable costs and expenses related to the transfer of District students to another provider.

(iii) If, after the notice of termination for failure to fulfill contract obligations, it is determined that the Provider has not so failed, the termination will be deemed to have been effected without cause pursuant to 15(a) above.

(iv) Provider will not be entitled to anticipatory, lost profits or consequential damages as a result of any termination under this section. Payments to the Provider in accordance with this section will constitute the Provider's exclusive remedy for any termination hereunder.

17. Severability Clause. If any provision of this Contract is held, in whole or in part, to be unenforceable for any reason, the remainder of that provision and of the entire Contract will be severable and remain in effect.

18. Written Notice. Notices required under this Contract will be valid when mailed first class postage or personally delivered to the following representatives, as indicated below.

For the District:
Amelia Sugden or Nadia Villapudua
Director/Manager, Special Education
Oxnard School District
1051 South "A" Street
Oxnard, CA 93030

For Tutorific:
Matt Oppenheimer
Executive Director / Owner
Tutorific!
484 Mobil Avenue, Suite 12
Camarillo, CA 93010

OXNARD SCHOOL DISTRICT:

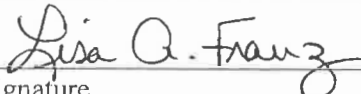

Signature

Lisa A. Franz, Director, Purchasing

8-10-18

Date

TUTORIFIC:



Signature

Matt Oppenheimer, Executive Director / Owner

7/10/18

Date

EXHIBIT A

INSURANCE

I. Insurance Requirements. Provider shall provide and maintain insurance, acceptable to the District Superintendent or District Counsel, in full force and effect throughout the term of this Agreement, against claims for injuries to persons or damages to property which may arise from or in connection with the performance of the work hereunder by Provider, its agents, representatives or employees. Insurance is to be placed with insurers authorized to conduct business in the State of California and with a current A.M. Best's rating of no less than A, as rated by the Current edition of Best's Key Rating Guide, published by A.M. Best Company, Oldwick, New Jersey 08858. Provider shall provide the following scope and limits of insurance:

A. Minimum Scope of Insurance. Coverage shall be at least as broad as:

(1) Commercial General Liability coverage of not less than one million dollars (\$1,000,000) combined single limit, bodily injury, personal injury and property damage liability per occurrence, in a form acceptable to the District.

(2) Comprehensive general and auto liability insurance with limits of not less than one million dollars (\$1,000,000) per accident for bodily injury and property damage per occurrence. A combined single limit policy with aggregate limits in an amount of not less than two million dollars (\$2,000,000) shall be considered equivalent to the said required minimum limit.

(3) Insurance Coverage shall include:

1. owned, non-owned and hired vehicles;
2. blanket contractual;
3. broad form property damage;
4. products/completed operations; and
5. personal injury.

(4) Workers' Compensation insurance as required by the laws of the State of California.

(5) Abuse and Molestation coverage of not less than two million dollars (\$2,000,000) per occurrence and five million dollars (\$5,000,000) aggregate.

(6) Professional liability (Errors and Omissions) insurance, including contractual liability, as appropriate to the Provider's profession. This coverage may be written on a "claims made" basis and must be endorsed to be applicable to claims based upon, arising out of or related to Services performed under this Agreement. The insurance must be maintained for at least 3 consecutive years following the later of the completion of the Services or the termination of this Agreement.

Failure to maintain professional liability insurance is a material breach of this Agreement and grounds for immediate termination.

II. Other Provisions. Insurance policies required by this Agreement shall contain the following provisions:

A. All Policies. Each insurance policy required by this Agreement shall be endorsed and state the coverage shall not be suspended, voided, cancelled by the insurer or either party to this Agreement, reduced in coverage or in limits except after 30 days' prior written notice by Certified mail, return receipt requested, has been given to District.

B. General Liability and Automobile Liability Coverages.

(1) District, and its respective elected and appointed officers, officials, and employees and volunteers are to be covered as additional insureds (collectively, "additional insureds") as respects the following: liability arising out of activities Provider performs; products and completed operations of Provider; premises owned, occupied or used by Provider ; or automobiles owned, leased, hired or borrowed by Provider. The coverage shall contain no special limitations on the scope of protection afforded to additional insureds.

(2) Each policy shall state that the coverage provided is primary and any insurance carried by any additional insured is in excess to and non-contributory with Provider's insurance.

(3) Provider's insurance shall apply separately to each insured against whom claim is made or suit is brought, except with respect to the limits of the insurer's liability.

(4) Any failure to comply with the reporting or other provisions of the policies including breaches of warranties shall not affect coverage provided to any additional insured.

III. Other Requirements. Provider agrees to deposit with District, at or before the effective date of this contract, certificates of insurance necessary to satisfy District that the insurance provisions of this contract have been complied with. The District may require that Provider furnish District with copies of original endorsements effecting coverage required by this Section. The certificates and endorsements are to be signed by a person authorized by that insurer to bind coverage on its behalf. District reserves the right to inspect complete, certified copies of all required insurance policies, at any time.

A. If any Services are performed by subcontractor, Provider shall furnish certificates and endorsements from each subcontractor identical to those Provider provides.

B. Any deductibles or self-insured retentions must be declared to and approved by District. At the option of District, either the insurer shall reduce or eliminate such deductibles or self-insured retentions as respects District or its respective elected or appointed officers, officials, employees and volunteers or the Provider shall procure a bond guaranteeing payment of losses and related investigations, claim administration, defense expenses and claims.

C. The procuring of any required policy or policies of insurance shall not be construed to limit Provider's liability hereunder nor to fulfill the indemnification provisions and requirements of this Agreement.

EXHIBIT B

CONFLICT OF INTEREST CHECK

Bylaws of the Board 9270(BB)E requires that the Superintendent or a designee make a determination, on a case by case basis, concerning whether disclosure will be required from a consultant to comply with the District's Conflict of Interest Code (commencing with Bylaws of the Board 9270 BB).

Consultants are required to file disclosures when, pursuant to a contract with the District, the consultant will make certain specified government decisions or will perform the same or substantially the same duties for the District as a staff person would.

The services to be performed by Provider under the Contract to which this Exhibit B is attached constitute do not constitute governmental decisions or staff services within the meaning of the Conflict of Interest Code. Therefore, the Provider, TUTORIFIC!, who will provide Services under the Contract, is is not subject to disclosure obligations.

Date: 8-10-18

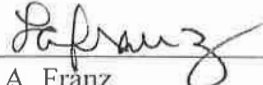
By: 
Lisa A. Franz
Director, Purchasing

OSD BOARD AGENDA ITEM

Name of Contributor: Dr. Anabolena DeGenna

Date of Meeting: 4/3/19

- Study Session:** _____
Closed Session _____
- A-1. Preliminary** _____
A-II. Reports _____
B. Hearings _____
C. Consent Agenda _____
- Agreement Category:**
____ Academic
____ Enrichment
 Special Education
____ Support Services
____ Personnel
____ Legal
____ Facilities
- D. Action Items** _____
F. Board Policies 1st Reading _____ **2nd Reading** _____

Ratification of Amendment #2 to Agreement #18-64 – Autism Learning Partners LLC (DeGenna/Sugden)

At the Board Meeting of August 22, 2018, the Board of Trustees ratified Agreement #18-64, in the amount of \$130,000.00, with Autism Learning Partners to work with the Special Education Services Department to provide 1:1 behavior support services. Services include ABA progress reporting, training and development for Special Education Personnel, Focused ABA services, social skills instruction, transition planning for students demonstrating progress, and positive collaboration with schools and parents.

At the Board Meeting of October 24, 2018, the Board of Trustees ratified Amendment #1 to Agreement #18-64, in the amount of \$218,210.00 to cover additional costs for embedded services, social skills groups/classes and professional training and development through the remainder of the fiscal year, for a new total agreement amount of \$348,210.00.

Amendment #2 is now required to adjust the total expected costs through the remainder of the fiscal year, in the amount not to exceed \$348,000.00, for a new total agreement amount of \$696,210.00.

FISCAL IMPACT:

Not to exceed \$348,000.00 - Special Education Funds

RECOMMENDATION:

It is the recommendation of the Director, Special Education Services, and the Assistant Superintendent, Educational Services, that the Board of Trustees ratify Amendment #2 to Agreement #18-64 with Autism Learning Partners LLC.

ADDITIONAL MATERIAL(S):

- Attached:** Amendment #2 (1 Page)
Amendment #1 (1 Page)
Agreement #18-64, Autism Learning Partners LLC (18 Pages)

**AMENDMENT #2 TO AGREEMENT #18-64 with
Autism Learning Partners
April 3, 2019**

At the Board Meeting of August 22, 2018, the Board of Trustees ratified Agreement #18-64, in the amount of \$130,000.00, with Autism Learning Partners to work with the Special Education Services Department to provide 1:1 behavior support services. Services include ABA progress reporting, training and development for Special Education Personnel, Focused ABA services, social skills instruction, transition planning for students demonstrating progress, and positive collaboration with schools and parents.

At the Board Meeting of October 24, 2018, the Board of Trustees ratified Amendment #1 to Agreement #18-64, in the amount of \$218,210.00 to cover additional costs for embedded services, social skills groups/classes and professional training and development through the remainder of the fiscal year, for a new total agreement amount of \$348,210.00.

Amendment #2 is now required to adjust the total expected costs through the remainder of the fiscal year, in the amount not to exceed \$348,000.00, for a new total agreement amount of \$696,210.00.

AUTISM LEARNING PARTNERS:

By: _____
Jeffrey P. Winter, President & CEO

Date: _____

OXNARD SCHOOL DISTRICT:

By: _____
Lisa A. Franz, Director of Purchasing

Date: _____

**AMENDMENT #1 TO AGREEMENT #18-64 with
Autism Learning Partners
October 24, 2018**

At the Board Meeting of August 22, 2018, the Board of Trustees approved Agreement #18-64, in the amount of \$130,000.00, with Autism Learning Partners to work with the Special Education Services Department to provide 1:1 behavior support services. Services include ABA progress reporting, training and development for Special Education Personnel, Focused ABA services, social skills instruction, transition planning for students demonstrating progress, and positive collaboration with schools and parents.

Amendment # 1 will cover additional costs for embedded services, social skills groups/classes and professional training and development through the remainder of the fiscal year, in the amount not to exceed \$ 218,210.00, for a new total agreement amount of \$348,210.00.

AUTISM LEARNING PARTNERS:

By: _____

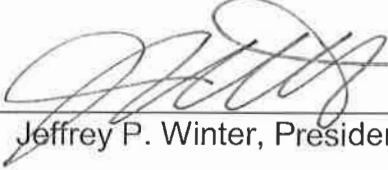
Jeffrey P. Winter, President & CEO

Date: _____

10/25/18

OXNARD SCHOOL DISTRICT:

By: _____

Lisa A. Franz, Director of Purchasing

Date: _____

10-30-18

OXNARD SCHOOL DISTRICT

Agreement #18-64

AGREEMENT FOR CONSULTANT SERVICES

This Agreement for Consultant Services ("Agreement") is entered into as of this 22nd day of August, 2018 by and between the Oxnard School District ("District") and Autism Learning Partners LLC ("Consultant"). District and Consultant are sometimes hereinafter individually referred to as "Party" and hereinafter collectively referred to as the "Parties."

RECITALS

- A. District is authorized by *California Government Code* Section 53060, and Board Policy 4368, to contract with independent contractors for the furnishing of services concerning financial, economic, accounting, engineering, legal, administrative and other matters. District has sought, by issuance of a Request for Proposals or Invitation for Bids, the performance of the Services, as defined and described particularly on Exhibit A, attached to this Agreement.
- B. Following submission of a proposal or bid for the performance of the Services, Consultant was selected by the District to perform the Services.
- C. The Parties desire to formalize the selection of Consultant for performance of the Services and desire that the terms of that performance be as particularly defined and described herein.

OPERATIVE PROVISIONS

NOW, THEREFORE, in consideration of the mutual promises and covenants made by the Parties and contained here and other consideration, the value and adequacy of which are hereby acknowledged, the parties agree as follows:

- Incorporation of Recitals and Exhibits.** The Recitals set forth above and all exhibits attached to this Agreement, as hereafter amended, are incorporated by this reference as if fully set forth herein.
- Term of Agreement.** Subject to earlier termination as provided below, this Agreement shall remain in effect from July 1, 2018 through June 30, 2019 (the "Term"). This Agreement may be extended only by amendment, signed by the Parties, prior to the expiration of the Term.
- Time for Performance.** The scope of services set forth in Exhibit A shall be completed during the Term pursuant to the schedule specified Exhibit A. Should the scope of services not be completed pursuant to that schedule, the Consultant shall be deemed to be in Default as provided below. The District, in its sole discretion, may choose not to enforce the Default provisions of this Agreement and may instead allow Consultant to continue performing the Services.
- Compensation and Method of Payment.** Subject to any limitations set forth below or elsewhere in this Agreement, District agrees to pay Consultant the amounts specified in Exhibit B "Compensation". The total compensation shall not exceed One Hundred Thirty Thousand Dollars (\$130,000.00), per the attached hourly rate sheet as listed, unless additional compensation is approved in writing by the District.

- a. Each month Consultant shall furnish to District an original invoice for all work performed and expenses incurred during the preceding month. The invoice shall detail charges by the following categories: labor (by sub-category), travel, materials, equipment, supplies, and sub-consultant contracts. Sub-consultant charges, if any, shall be detailed by the following categories: labor, travel, materials, equipment and supplies. District shall independently review each invoice submitted by the Consultant to determine whether the work performed and expenses incurred are in compliance with the provisions of this Agreement. In the event that no charges or expenses are disputed, the invoice shall be approved and paid according to the terms set forth in subsection b. In the event any charges or expenses are disputed by District, the original invoice shall be returned by District to Consultant for correction and resubmission.
- b. Except as to any charges for work performed or expenses incurred by Consultant which are disputed by District, District will use its best efforts to cause Consultant to be paid within forty-five (45) days of receipt of Consultant's correct and undisputed invoice.
- c. Payment to Consultant for work performed pursuant to this Agreement shall not be deemed to waive any defects in work performed by Consultant.

5. **Termination.** This Agreement may be terminated at any time by mutual agreement of the Parties or by either Party as follows:

- a. District may terminate this Agreement, with or without cause, at any time by giving thirty (30) days written notice of termination to Consultant. In the event such notice is given, Consultant shall cease immediately all work in progress; or
- b. Consultant may terminate this Agreement for cause at any time upon thirty (30) days written notice of termination to District.

6. **Inspection and Final Acceptance.** District may, at its discretion, inspect and accept or reject any of Consultant's work under this Agreement, either during performance or when within sixty (60) days after submitted to District. If District does not reject work by a timely written explanation, Consultant's work shall be deemed to have been accepted. District's acceptance shall be conclusive as to such work except with respect to latent defects, fraud and such gross mistakes as amount to fraud. Acceptance of any of Consultant's work by District shall not constitute a waiver of any of the provisions of this Agreement including, but not limited to indemnification and insurance provisions.

7. **Default.** Failure of Consultant to perform any Services or comply with any provisions of this Agreement may constitute a default. The District may give notice to Consultant of the default and the reasons for the default. District shall not have any obligation or duty to continue compensating Consultant for any work performed after the date of the notice until the default is cured. The notice shall include the timeframe in which Consultant may cure the default. This timeframe is presumptively thirty (30) days, but may be extended, though not reduced, at the discretion of the District. During the period of time that Consultant is in default, the District shall hold all invoices and shall, when the default is cured, proceed with payment on the invoices. In the alternative, the District may, in its sole discretion, elect to pay some or all of the outstanding invoices during the period of default. If Consultant does not cure the default, the District may terminate this Agreement as provided above. Any failure on the part of the District to give notice of the Consultant's default shall not be deemed to result in a waiver of the District's legal rights or any rights arising out of any provision of this Agreement.

8. **Ownership of Documents.** All maps, models, designs, drawings, photographs, studies, surveys, reports, data, notes, computer files, files and other documents prepared, developed or discovered by Consultant in the course of providing any services pursuant to this Agreement (collectively and individually, the "Documents") shall

become the sole property of District and may be used, reused or otherwise disposed of by District without the permission of the Consultant. Upon completion, expiration or termination of this Agreement, Consultant shall turn over to District all such Documents.

9. **Use of Documents by District.** If and to the extent that District utilizes for any purpose not related to this Agreement any Documents, Consultant's guarantees and warrants related to Standard of Performance under this Agreement shall not extend to such use of the Documents.

10. **Consultant's Books and Records.** Consultant shall maintain any and all documents and records demonstrating or relating to Consultant's performance of services pursuant to this Agreement for a minimum of three years after termination or expiration of this Agreement, or longer if required by law.

- a. Consultant shall maintain any and all ledgers, books of account, invoices, vouchers, canceled checks, or other documents or records evidencing or relating to work, services, expenditures and disbursements charged to District pursuant to this Agreement for a minimum of three years, or longer if required by law, all in accordance with generally accepted accounting principles and with sufficient detail so as to permit an accurate evaluation of the services provided by Consultant pursuant to this Agreement.
- b. Any and all such records or documents shall be made available for inspection, audit and copying, at any time during regular business hours, upon request by District or its designated representative. Copies of such documents or records shall be provided directly to the District for inspection, audit and copying when it is practical to do so; otherwise, unless an alternative is mutually agreed upon, such documents and records shall be made available at Consultant's address indicated for receipt of notices in this Agreement.
- c. District has the right to acquire custody of such records by written request if Consultant decides to dissolve or terminate its business. Consultant shall deliver or cause to be delivered all such records and documents to District within sixty (60) days of receipt of the request.

11. **Independent Contractor.** Consultant is and shall at all times remain a wholly independent contractor and not an officer, employee or agent of District.

- a. The personnel performing the services under this Agreement on behalf of Consultant shall at all times be under Consultant's exclusive direction and control. Consultant, its agents or employees shall not at any time or in any manner represent that Consultant or any of Consultant's officers, employees, or agents are in any manner officials, officers, employees or agents of District. Neither Consultant, nor any of Consultant's officers, employees or agents, shall, by virtue of services rendered under this Agreement, obtain any rights to retirement, health care or any other benefits which may otherwise accrue to District's employees. Consultant will be responsible for payment of all Consultant's employees' wages, payroll taxes, employee benefits and any amounts due for federal and state income taxes and Social Security taxes since these taxes will not be withheld from payment under this agreement.
- b. Consultant shall have no authority to bind District in any manner, or to incur any obligation, debt or liability of any kind on behalf of or against District, whether by contract or otherwise, unless such authority is expressly conferred in writing by District, or under this Agreement.

12. **Standard of Performance.** Consultant represents and warrants that it has the qualifications, experience and facilities necessary to properly perform the services required under this Agreement in a thorough, competent and professional manner. Consultant shall at all times faithfully, competently and to the best of its ability, experience and talent, perform all services described herein. In meeting its obligations under this Agreement,

Consultant shall employ, at a minimum, generally accepted standards and practices utilized by persons engaged in providing services similar to those required of Consultant under this Agreement.

13. **Confidential Information.** All information gained during performance of the Services and all Documents or other work product produced by Consultant in performance of this Agreement shall be considered confidential. Consultant shall not release or disclose any such information, Documents or work product to persons or entities other than District without prior written authorization from the Superintendent of the District, except as may be required by law.

- a. Consultant shall promptly notify District if it is served with any summons, complaint, subpoena or other discovery request, court order or other request from any party regarding this Agreement or the work performed hereunder.
- b. District retains the right, but has no obligation, to represent Consultant or be present at any deposition, hearing or similar proceeding. Consultant agrees to cooperate fully with District and to provide District with the opportunity to review any response to discovery requests provided by Consultant; provided that this does not imply or mean the right by District to control, direct, or rewrite said response.

14. **Conflict of Interest; Disclosure of Interest.** Consultant covenants that neither it, nor any officer or principal of its firm, has or shall acquire any interest, directly or indirectly, which would conflict in any manner with the interests of District or which would in any way hinder Consultant's performance of services under this Agreement. Consultant further covenants that in the performance of this Agreement, no person having any such interest shall be employed by it as an officer, employee, agent or subcontractor without the express written consent of the District.

- a. Consultant agrees to at all times avoid conflicts of interest or the appearance of any conflicts of interest with the interests of District in the performance of this Agreement.
- b. Bylaws of the Board 9270 BB and 9270(BB) E, as hereinafter amended or renumbered, require that a Consultant that qualifies as a "designated employee" must disclose certain financial interests by filing financial interest disclosures. By its initials below, Consultant represents that it has received and reviewed a copy of the Bylaws of the Board 9270 BB and 9270(BB) E and that it [] does [] does not qualify as a "designated employee".



____ (Initials)

- c. Consultant agrees to notify the Superintendent, in writing, if Consultant believes that it is a "designate employee" and should be filing financial interest disclosures, but has not been required to do so by the District.

____ (Initials)

15. **Compliance with Applicable Laws.** In connection with the Services and its operations, Consultant shall keep itself informed of and comply with all applicable federal, state and local laws, statutes, codes, ordinances, regulations and rules including, but not limited to, minimum wages and/or prohibitions against discrimination, in effect during the Term. Consultant shall obtain any and all licenses, permits and authorizations necessary to perform the Services. Neither District, nor any elected or appointed boards, officers, officials, employees or agents of District shall be liable, at law or in equity, as a result of any failure of Consultant to comply with this section.

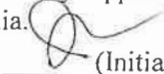
- a. Without limiting the generality of the foregoing, Consultant shall comply with any applicable fingerprinting requirements as set forth in the Education Code of the State of California.

____ (Initials)

16. **Unauthorized Aliens.** Consultant hereby promises and agrees to comply with all of the provisions of the Federal Immigration and Nationality Act, 8 U.S.C.A. §§ 1101, et seq., as amended, and in connection therewith, shall not employ "unauthorized aliens" as that term is defined in 8 U.S.C.A. §1324a(h)(3). Should Consultant so employ such individuals for the performance of work and/or services covered by this Agreement, and should any liability or sanctions be imposed against District for such employment, Consultant hereby agrees to and shall reimburse District for the cost of all such liabilities or sanctions imposed, together with any and all costs, including attorneys' fees, incurred by District.

17. **Non-Discrimination.** Consultant shall abide by the applicable provisions of the United States Civil Rights Act of 1964 and other provisions of law prohibiting discrimination and shall not discriminate, in any way, against any person on the basis of race, color, religious creed, national origin, ancestry, sex, age, physical handicap, medical condition or marital status in connection with or related to the performance of this Agreement.

18. **Assignment.** The expertise and experience of Consultant are material considerations for this Agreement. District has an interest in the qualifications of and capability of the persons and entities that will fulfill the duties and obligations imposed upon Consultant under this Agreement. In recognition of that interest, Consultant shall not assign or transfer this Agreement or any portion of this Agreement or the performance of any of Consultant's duties or obligations under this Agreement without the prior written consent of the Board of Directors of the District. Any attempted assignment shall be ineffective, null and void, and shall constitute a material breach of this Agreement entitling District to any and all remedies at law or in equity, including summary termination of this Agreement.

19. **Subcontracting.** Notwithstanding the above, Consultant may utilize subcontractors in the performance of its duties pursuant to this Agreement, but only with the prior written consent of the District. The Consultant shall be as fully responsible to the District for the acts and omissions of his Subcontractors, and of persons either directly or indirectly employed by him/her, as if the acts and omissions were performed by him/her directly.

20. **Continuity of Personnel.** Consultant shall make every reasonable effort to maintain the stability and continuity of Consultant's staff and subcontractors, if any, assigned to perform the services required under this Agreement.

- a. Consultant shall insure that District has a current list of all personnel and sub-contractors providing services under this Agreement.
- b. Consultant shall notify District of any changes in Consultant's staff and subcontractors, if any, assigned to perform the services required under this Agreement, prior to and during any such performance. The list notice shall include the following information: (1) all full or part-time staff positions by title, including volunteer positions whose direct services are required to provide the services described herein; (2) a brief description of the functions of each such position and the hours each position works each week or, for part-time positions, each day or month, as appropriate; (3) the professional degree, if applicable, and experience required for each position; and (4) the name of the person responsible for fulfilling the terms of this Agreement.

21. **Indemnification.**

- a. Consultant agrees to defend, indemnify, and hold harmless District, its officers, agents, employees, and/or volunteers from any and all claims, demands, losses, damages and expenses, including legal fees and costs, or other obligations or claims arising out of any liability or damage to property, or any other loss, sustained or claimed to have been sustained arising out of activities of the Consultant or those of any of Consultant's officers, agents, employees, or subcontractors, whether such act or omission is authorized by this Agreement or not. Consultant shall also pay for any and all damage to the Property of the District, or loss or theft of such Property, done or caused by such persons. District

assumes no responsibility whatsoever for any property placed on district premises. Consultant further agrees to waive all rights of subrogation against the District. The provisions of this Agreement do not apply to any damage or losses caused solely by the negligence of the District or any of its officers, agents, employees, and/or volunteers.

 (Initials)

- b. The provisions of this section do not apply to claims occurring as a result of District's sole negligence or willful acts or omissions.

22. **Insurance.** Consultant agrees to obtain and maintain in full force and effect during the term of this Agreement the insurance policies set forth in Exhibit C "Insurance" and made a part of this Agreement. All insurance policies shall be subject to approval by District as to form and content. These requirements are subject to amendment or waiver if so approved in writing by the District Superintendent. Consultant agrees to provide District with copies of required policies upon request.

23. **Notices.** All notices required or permitted to be given under this Agreement shall be in writing and shall be personally delivered, or sent by telecopier or certified mail, postage prepaid and return receipt requested, addressed as follows:

To District: Oxnard School District
1051 South A Street
Oxnard, California, 93030
Attention: Amelia Sugden
Phone: 805.385.1501, x2175
Fax: 805.487.9648

To Consultant: Autism Learning Partners LLC
505 N. Brand Blvd., Suite #1000
Glendale, CA 91203
Attention: Nani Escudero
Phone: (818) 241.6780, x295
Fax:
Email: nescudero@autismlearningpartners.com

Notice shall be deemed effective on the date personally delivered or transmitted by facsimile (provided confirmation of successful facsimile transmission shall be retained) or, if mailed, three (3) days after deposit of the same in the custody of the United States Postal Service.

24. **Excusable Delays.** Consultant shall not be liable for damages, including liquidated damages, if any, caused by delay in performance or failure to perform due to causes beyond the control of Consultant. Such causes include, but are not limited to, acts of God, acts of the public enemy, acts of federal, state or local governments, acts of District, court orders, fires, floods, epidemics, strikes, embargoes, and unusually severe weather. The term and price of this Agreement shall be equitably adjusted for any delays due to such causes.

25. **Authority to Execute.** The person or persons executing this Agreement on behalf of Consultant represents and warrants that he/she/they has/have the authority to so execute this Agreement and to bind Consultant to the performance of its obligations hereunder.

26. **Administration.** AMELIA SUGDEN shall be in charge of administering this Agreement on behalf of the District. The Director of Purchasing has completed Exhibit D "Conflict of Interest Check" attached hereto.

27. **Binding Effect.** This Agreement shall be binding upon the heirs, executors, administrators, successors and assigns of the parties.

28. **Entire Agreement.** This Agreement and the exhibits and documents incorporated herein constitute the entire agreement and understanding between the parties in connection with the matters covered herein.

29. **Amendment.** No amendment to or modification of this Agreement shall be valid or binding unless made in writing by the Consultant and by the District. The parties agree that this requirement for written modifications cannot be waived and that any attempted waiver shall be void.

30. **Waiver.** Waiver by any party to this Agreement of any term, condition, or covenant of this Agreement shall not constitute a waiver of any other term, condition, or covenant. Waiver by any party of any breach of the provisions of this Agreement shall not constitute a waiver of any other provision or a waiver of any subsequent breach or violation of any provision of this Agreement. Acceptance by District of any work or services by Consultant shall not constitute a waiver of any of the provisions of this Agreement.

31. **Governing Law.** This Agreement shall be interpreted, construed and governed according to the laws of the State of California. In the event of litigation between the parties, venue in state trial courts shall lie exclusively in the County of Ventura, California.

32. **Arbitration.** Any dispute arising out of the performance of this Agreement shall be resolved by binding arbitration in accordance with rules and procedures of the American Arbitration Association.

33. **Severability.** If any term, condition or covenant of this Agreement is declared or determined by any court of competent jurisdiction to be invalid, void or unenforceable, the remaining provisions of this Agreement shall not be affected thereby and the Agreement shall be read and construed without the invalid, void or unenforceable provision(s).

[THE REMAINDER OF THIS PAGE IS INTENTIONALLY LEFT BLANK]

IN WITNESS WHEREOF, the District and Consultant have executed and delivered this agreement for consultant services as of the date first written above.

OXNARD SCHOOL DISTRICT:

AUTISM LEARNING PARTNERS LLC:

Lisa A. Franz
Signature

[Signature]
Signature

Lisa A. Franz, Director, Purchasing
Typed Name/Title

ESD
Typed Name/Title

8-29-18
Date

8/29/18
Date

Tax Identification Number: 95-6002318

Tax Identification Number: _____

Not Project Related

Project #18-64

EXHIBIT A
TO AGREEMENT FOR CONSULTANT SERVICES #18-64

SERVICES

I. Consultant will perform the following Services under the Captioned Agreement:

***PER ATTACHED 2018-2019 RATE SHEET**

II. As part of the Services, Consultant will prepare and deliver the following tangible work products to the District:

***PER ATTACHED 2018-2019 RATE SHEET**

III. During performance of the Services, Consultant will keep the District apprised of the status of performance by delivering the following status reports under the indicated schedule:

STATUS REPORT FOR ACTIVITY:	DUE DATE
A. N/A	
B. N/A	
C. N/A	
D. N/A	

V. Consultant will utilize the following personnel to accomplish the Services:

None.

See attached list.

VI. Consultant will utilize the following subcontractors to accomplish the Services (check one):

None.

See attached list.

VII. AMENDMENT

The Scope of Services, including services, work product, and personnel, are subject to change by mutual Agreement. In the absence of mutual Agreement regarding the need to change any aspects of performance, Consultant shall comply with the Scope of Services as indicated above

Not Project Related

Project #18-64

EXHIBIT B
TO AGREEMENT FOR CONSULTANT SERVICES #18-64

COMPENSATION

I. Consultant shall use the following rates of pay in the performance of the Services:

Total compensation shall not exceed One Hundred Thirty Thousand Dollars (\$130,000.00), per the attached 2018-2019 Rate Sheet, unless additional compensation is approved in writing by the District.

II. Consultant may utilize subcontractors as indicated in this Agreement. The hourly rate for any subcontractor is not to exceed \$ N/A per hour without written authorization from the District Superintendent or his designee.

III. The District will compensate Consultant for the Services performed upon submission of a valid invoice. Each invoice is to include:

- A. Line items for all personnel describing the work performed, the number of hours worked, and the Hourly or flat rate.
- B. Line items for all supplies properly charged to the Services.
- C. Line items for all travel properly charged to the Services.
- D. Line items for all equipment properly charged to the Services.
- E. Line items for all materials properly charged to the Services.
- F. Line items for all subcontractor labor, supplies, equipment, materials, and travel properly charged to the Services.

IV. The total compensation for the Services shall not exceed \$130,000.00, as provided in Section 4 of this Agreement.

Not Project Related

Project #18-64

EXHIBIT C
TO AGREEMENT FOR CONSULTANT SERVICES #18-64

INSURANCE

I. Insurance Requirements. Consultant shall provide and maintain insurance, acceptable to the District Superintendent or District Counsel, in full force and effect throughout the term of this Agreement, against claims for injuries to persons or damages to property which may arise from or in connection with the performance of the work hereunder by Consultant, its agents, representatives or employees. Insurance is to be placed with insurers authorized to conduct business in the State of California and with a current A.M. Best's rating of no less than A, as rated by the Current edition of Best's Key Rating Guide, published by A.M. Best Company, Oldwick, New Jersey 08858. Consultant shall provide the following scope and limits of insurance:

A. Minimum Scope of Insurance. Coverage shall be at least as broad as:

(1) Commercial General Liability coverage of not less than two million dollars (\$2,000,000) Aggregate and one million dollars (\$1,000,000) per occurrence.

(2) Auto liability insurance with limits of not less than one million dollars (\$1,000,000).

(3) Insurance coverage should include:

1. owned, non-owned and hired vehicles;
2. blanket contractual;
3. broad form property damage;
4. products/completed operations; and
5. personal injury.

(4) Workers' Compensation insurance as required by the laws of the State of California.

(5) Abuse and Molestation coverage of not less than two million dollars (\$2,000,000) per occurrence and five million dollars (\$5,000,000) Aggregate.

II. Other Provisions. Insurance policies required by this Agreement shall contain the following provisions:

A. All Policies. Each insurance policy required by this Agreement shall be endorsed and state the coverage shall not be suspended, voided, cancelled by the insurer or either party to this Agreement, reduced in coverage or in limits except after 30 days' prior written notice by Certified mail, return receipt requested, has been given to District

B. General Liability, Automobile Liability, and Abuse/Molestation Coverages.

(1) District, and its respective elected and appointed officers, officials, employees and volunteers are to be covered as additional insureds (collectively, "additional insureds") as respects the following: liability arising out of activities Consultant performs; products and completed operations of Consultant; premises owned, occupied or used by Consultant ; automobiles owned, leased, hired or borrowed by Consultant, and

Not Project Related

Project #18-64

Abuse/Molestation. The coverage shall contain no special limitations on the scope of protection afforded to additional insureds.

(2) Each policy shall state that the coverage provided is primary and any insurance carried by any additional insured is in excess to and non-contributory with Consultant's insurance.

(3) Consultant's insurance shall apply separately to each insured against whom claim is made or suit is brought, except with respect to the limits of the insurer's liability.

(4) Any failure to comply with the reporting or other provisions of the policies including breaches of warranties shall not affect coverage provided to any additional insured.

III. Other Requirements. Consultant agrees to deposit with District, at or before the effective date of this contract, certificates of insurance necessary to satisfy District that the insurance provisions of this contract have been complied with. The District may require that Consultant furnish District with copies of original endorsements effecting coverage required by this Section. The certificates and endorsements are to be signed by a person authorized by that insurer to bind coverage on its behalf. District reserves the right to inspect complete, certified copies of all required insurance policies, at any time.

A. If any Services are performed by subcontractor, Consultant shall furnish certificates and endorsements from each subcontractor identical to those Consultant provides.

B. Any deductibles or self-insured retentions must be declared to and approved by District. At the option of District, either the insurer shall reduce or eliminate such deductibles or self-insured retentions as respects District or its respective elected or appointed officers, officials, employees and volunteers or the Consultant shall procure a bond guaranteeing payment of losses and related investigations, claim administration, defense expenses and claims.

C. The procuring of any required policy or policies of insurance shall not be construed to limit Consultant's liability hereunder nor to fulfill the indemnification provisions and requirements of this Agreement.

Not Project Related

Project #18-64

EXHIBIT D
TO AGREEMENT FOR CONSULTANT SERVICES #18-64

CONFLICT OF INTEREST CHECK

Bylaws of the Board 9270(BB)E requires that the Superintendent or a designee make a determination, on a case by case basis, concerning whether disclosure will be required from a consultant to comply with the District's Conflict of Interest Code (commencing with Bylaws of the Board 9270 BB).

Consultant's are required to file disclosures when, pursuant to a contract with the District, the Consultant will make certain specified government decisions or will perform the same or substantially the same duties for the District as a staff person would.

The services to be performed by Consultant under the Agreement to which this Exhibit D is attached constitute do not constitute governmental decisions or staff services within the meaning of the Conflict of Interest Code. Therefore, the Consultant, AUTISM LEARNING PARTNERS LLC, who will provide Services under the Agreement, is is not subject to disclosure obligations.

Date: 8-29-18

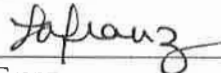
By: 
Lisa A. Franz
Director, Purchasing

Rate Sheet
Autism Learning Partners

**RATE SHEET
2018-2019**

SERVICE	RATE PER HOUR
<i>Description</i>	
1:1 Direct Service by Behavior Technician - Behavior Intervention Implementation (BII)	\$55.00
Social Skills Classes Group Rate (per student ratio of 1:2 or 1:3) * Group rate requires a minimum of two students. Groups of 4 or more will require two staff members *1-1 social skills classes available at the BII 1-1 Direct Service Rate listed above	\$40.00
Clinical Supervision by Master Level – Behavior Intervention Development (BID)	\$80.00
Clinical Supervision by BCBA – Behavior Intervention Development (BID)	\$100.00
Functional Behavior Assessment by Master’s Level Staff	\$80.00
Functional Behavior Assessment by BCBA	\$100.00
Group Training by Master’s Level Staff	\$80.00
Group Training by BCBA	\$100.00

Tax ID: 26-3494212

Rate Sheet Autism Learning Partners

About Autism Learning Partners (ALP)

Autism Learning Partners is a national leader in the field of special needs services and a full service provider that specializes in the treatment of autism and other developmental disabilities. Our broad thinking approach addresses the whole child by collaborating with school administrators, doctors, therapists, and specialists. Our goal is to work together to make progress possible.

For close to 30 years, **Autism Learning Partners** has been a leader in the delivery of Applied Behavior Analysis (ABA) for children with Autism, providing comprehensive clinical services (BII, BID), as well as Social Skills Training/Groups and Early Intervention Services. Our commitment is to provide the highest level of clinical care and collaborate closely with school district personnel, including empowering and training teachers and school administrators to provide the highest level of ABA therapy while providing outcome focused care and supporting schools with cost savings strategies which include, progress reporting, and transition planning for students who demonstrate progress, significant and sustainable improvement and meet measured goals. Autism Learning Partners is unique as services are provided in the school, home and in the community.

Autism Learning Partners (ALP) focuses on:

- 1-1 ABA School Support & In-Home Services
- ABA Progress Reporting
- Training & Development for Special Education Personnel
- Quality Clinical and Outcome Focused ABA Services
- Social Skills Instruction
- Transition Planning for Students Demonstrating Progress
- Positive Collaboration with Schools and Parents

Our desire is to be the best and most trusted partner to your school for the provision of ABA services for special needs children and support the child's social, interpersonal and academic development by working as a coordinated team.

Mission:

The mission of Autism Learning Partners is to provide the highest level of clinical expertise to facilitate significant and sustainable improvement for the individuals and families we serve.

**Rate Sheet
Autism Learning Partners**

Our Vision:

Autism Learning Partners strives to give hope, support and paths of progress for children and their families living with Autism and related disorders. We believe that a tailored, comprehensive care plan managed by our exceptional clinical talent, partnered with love and commitment of all staff collaborating with the child including integrating the family into treatment, allows each child to achieve his or her maximum potential.

Section I:

Overview of Services

Autism Learning Partners is committed to providing quality clinical care on all cases assigned and is also committed to developing staff and sharing our expertise for the development of the special needs program. Prior to the onset of services, Autism Learning Partners can provide a **one time orientation of services** at no cost to your school.

Deliverables

Clinical Services:

Autism Learning Partners provides clinically appropriate and effective treatment services individualized to fit the classroom and students' needs. To this end the following services are recommended:

1:1 Direct Services: - Behavior Technician (BT)

ALP will offer (ABA) trained Behavior Technicians (BT) to support students with a higher level of need in a 1:1 capacity in the classroom. Behavior Technicians work under the supervision of a Board Certified Behavior Analyst (BCBA) or Master's Level Staff. The BT will provide support to help the student successfully and independently function in the classroom environment and address/reduce challenging behaviors to help the student access the curriculum. This service should be reviewed quarterly to adjust the level of support as to not interfere with the students independence should progress have been made.

Clinical Supervision by a Board Certified Behavior Analyst (BCBA) or Master's Level Staff

A Board Certified Behavior Analyst (BCBA) is a graduate-level staff who is board certified in behavior analysis and provides behavior-analytic services. BCBA's supervise the work of Behavior Technicians and other staff who implement behavior-analytic interventions (Applied Behavior Analysis - an Evidenced Based Intervention for special needs students). BCBA's directly support the needs of Special Education Departments.

www.AutismLearningPartners.com

73 N Palm St, Suite F1, Ventura, CA 93001

505 N. Brand Blvd. Suite 1000, Glendale, CA 91203

Email: nescudero@autismlearningpartners.com Phone: 818-241-6780, Ext. 295

Rate Sheet

Autism Learning Partners

(Continued) - Clinical Supervision by a Board Certified Behavior Analyst (BCBA) or Master's Level Staff

Consultation or Clinical supervision is provided by a BCBA or Masters Level Staff and is designed to support Special Education Departments based on services needed and also provides parent education as deemed fit by the school. ALP is available to help support staff in creating and implementing behavior programs.

Clinical Supervision in a school setting consists of overseeing a child's behavior plan. The plan is implemented by an interventionist or trained behavior aid and is overseen by a clinical supervisor who is continually updating goals as a child reaches mastery criteria.

Support is provided to staff to make sure everyone is on board with the intervention plan and is following through. The ultimate goal is to reduce challenging behaviors in the classroom so that the student can access the curriculum.

The Clinical Supervisor will meet with designated school personnel, as identified by the Special Education Department, to discuss behavioral plans, concerns and challenges that the student is experiencing in the classroom and determine an intervention plan based on the IEP and clinical observation. ALP works with staff to determine an appropriate transition plan. Services are faded once the student's challenging behaviors have been reduced, the student has reached maximized independence and when the student no longer needs support and is ready to be mainstreamed with typical peers.

Functional Behavior Assessment by BCBA or Master's Level Staff

A Functional Behavior Assessment is conducted by a BCBA and is designed to help us understand why a certain behavior is occurring. Once the assessment is completed and the BCBA determines the reason an inappropriate behavior may be occurring, we can then influence the behavior. All behaviors have a function and the goal is to teach the student an appropriate replacement behavior while extinguishing inappropriate behaviors.

It is critical that challenging behaviors are observed and other target skills for acquisition within this initial assessment. The length of this assessment can vary. From there, a treatment plan is designed and submitted to the special education department that recommends treatment services based on the individual needs of the student.

Rate Sheet Autism Learning Partners

Social Skills Classes – Group Rate (ratio of 1:2 or 1:3)

One of the most prevalent challenges for individuals with autism spectrum disorder is in the area of social skills. This includes difficulty with observational skills, eye contact, play interactions, social pragmatics, taking another's perspective, making inferences, and sharing enjoyment and building relationships.

The assessment and intervention "matching" process is different from a one-size-fits all approach that involves generic behavioral interventions for unique and individual behavioral excesses and deficits. We believe that achievement in the domain of social interaction greatly improves the quality of life for a learner and we place a premium on screening, assessment, and individually tailored interventions.

Training – Staff & Parent Training

ALP offers training to teachers and classroom aides on behavioral intervention principles to facilitate progress and support for students with these needs. Training will focus on various aspects of behavioral intervention including reinforcement, environmental manipulation, prompting hierarchy and managing maladaptive behaviors. The structure of the training is to provide hands-on training at first and then gradually fade back until mastery on the above intervention is displayed.

ALP can also provide workshops for parents on the above topics to reinforce techniques taught to students and encourage continued progress in the home. For full list of Training Topics, please see training Flyer.

Autism Learning Partners strives to serve as the best and most trusted partner to your school and empower special needs children's in the road to progress by working as a coordinated team. For additional information, visit www.autismlearningpartners.com.

Proposal Contact Info

Clinical questions, contact:

Sherri D. Ragan, LMFT, BCBA, Associate Clinical Director
73 N Palm St, Suite F1, Ventura, CA 93001
818.298.4574 Cell, SRagan@autismlearningpartners.com
www.autismlearningpartners.com

Questions regarding this proposal, contact:

Nani Escudero, Director of Community Partnerships & Development
818.241.6780 ext. 295 Office, nescudero@autismlearningpartners.com

BOARD AGENDA ITEM

Name of Contributor: Janet Penanhoat

Date of Meeting: 4/3/19

STUDY SESSION _____

CLOSED SESSION _____

SECTION A-I: PRELIMINARY _____

SECTION A-II: REPORTS _____

SECTION B: HEARINGS _____

SECTION C: CONSENT AGENDA _____

_____ Agreement Category:

_____ Academic

_____ Enrichment

_____ Special Education

_____ Support Services

_____ Personnel

_____ Legal

 X Facilities

SECTION D: ACTION _____

SECTION F: BOARD POLICIES 1st Reading _____ 2nd Reading _____

Approval of Work Authorization Letter #10S to NV5 West Inc., for DSA Inspector of Record (IOR) Services for the Marshall New Classroom Building Project (Penanhoat/Fateh/CFW)

At the November 13, 2013, regularly scheduled Board Meeting, the Board of Trustees approved Agreement #13-130 with NV5 West Inc. (formerly known as Nolte-Vertical 5.) to provide DSA Inspector of Record Services.

The District, in consultation with CFW recommends issuing Work Authorization Letter #10S to NV5 West Inc., to continue the provision of continuous DSA Inspector of Record Services through the completion of the Marshall New Classroom Building Project.

The Work Authorization Letter is issued pursuant to and consists of:

Master Agreement: **#13-130**

Work Authorization Letter: **#10S**

Consultant: **NV5 West Inc.**

Date Issued: **4/3/19**

The attached Work Authorization Letter describes the scope of services requested from NV5 West Inc., and calls for the continued performance of DSA Inspector of Record Services to ensure that the construction work is in accordance with DSA.

FISCAL IMPACT

The DSA Inspector of Record Services will be completed for a fee of: **Ninety-Nine Thousand Five Hundred Sixty Dollars and Zero Cents (\$99,560.00)** to be funded from the Master Construct and Implementation Program

RECOMMENDATION

It is the recommendation of the Assistant Superintendent, Business & Fiscal Services, and the Director of Facilities, in consultation with Caldwell Flores Winters, that the Board of Trustees approve WAL #10S for Master Agreement #13-130 with NV5 West Inc.

ADDITIONAL MATERIAL(S)

Attached:

- WAL #10S, NV5 West Inc. (1 Page)
- NV5 West Inc., Proposal, March 5, 2019 (1 Page)
- Master Agreement #13-130, Nolte-Vertical 5 (29 Pages)

	WORK AUTHORIZATION LETTER	
	GENERAL INFORMATION	
	PROJECT #: SITE NAME: Marshall Elementary School MASTER AGREEMENT #: 13-130 WAL #: 10S	DATE: 4/3/2019 DSA #: 03-116806 OPSC #: 72538-91 VENDOR ID:
PURSUANT TO MASTER AGREEMENT BETWEEN:		
DISTRICT	CONSULTANT	
OXNARD SCHOOL DISTRICT 1051 South A Street Oxnard, CA 93030 (805) 385-1501	Firm Name: Street: City, State, Zip: Phone:	NV5 West Inc. 1868 Palma Drive, Ste A Ventura, CA 93003 805.656.6074
SCOPE OF SERVICES TO BE PERFORMED UNDER THIS WAL		
NV5 West Inc., will be performing Inspection services as required by the District for Department of the State Architect. The Inspector of Record ("IOR") shall provide adequate coverage to required inspections of the work, from NTP to close-out; as outlined on the DSA approved documents and the DSA 103 forms. This supplemental WAL covers the period from April 31, 2019 to August 31, 2019. Provide routine inspections, coordinate special inspections and off-site inspections, shall maintain active communication with project team, review, approval, filing, archiving of project documents including RFIs, submittals, change orders, daily reports and any other documents that require IOR's approval and/or review as required by DSA. <i>(ATTACH ADDITIONAL PAGES AS NECESSARY)</i>		
SCHEDULE OF SERVICES TO BE PERFORMED UNDER THIS WAL		
START DATE: April 31,2019	COMPLETION DATE: August 31, 2019 or Project Closeout	
FIXED FEE AMOUNT: <u>Ninty Nine Thousand Five Hundred Sixty Dollars and Zero Cents (\$ 99,560.00)</u>		
<i>This fee amount is based upon Consultant's proposal dated <u>3/5/19</u> and subsequent negotiations mutually agreed to by all parties</i>		
<i>This WAL is inherently a part of the Master Agreement referenced above. It is bound by the general terms and conditions of the Master Agreement. This WAL describes in detail the Consultants' specific Scope of Services, agreed upon lump sum fixed fee, agreed upon schedule for completion of Services, and other provisions required to clearly indicate the required Services, and terms of this WAL.</i>		
<i>This WAL and associated Master Agreement hereby supercede any and all terms, conditions, and other provisions of the Consultant's Proposal; and such terms, conditions, and other provisions are null and void, and are not incorporated to any extent as part of this WAL and associated Master Agreement whether or not they are directly superceded by this WAL and/or the associated Master Agreement.</i>		
IN WITNESS THEREOF, THE PARTIES HAVE AGREED TO AND EXECUTED THIS WAL AS SET FORTH BELOW:		
DISTRICT	CONSULTANT	
OXNARD SCHOOL DISTRICT	CONSULTANT	
(SIGNATURE)	(DATE)	(SIGNATURE)
FOR DISTRICT USE ONLY		
PROJECT MANAGER: Mario Mera P.O. # SOURCE OF FUNDS: <input type="checkbox"/> MEASURE "R" <input type="checkbox"/> DEF. MAINT. <input type="checkbox"/> DEV. FEES <input checked="" type="checkbox"/> OTHER: Master Construct and Implementation Program COST ID: 6290		PREPARED BY: Sean Mahan P.O. AMOUNT:
(PM APPROVAL SIGNATURE)	(DATE)	



Change Order No. 2

Date March 5, 2019
Job No. 114517-0002195.00

CLIENT
OSD c/o Caldwell Flores Winters, Inc.
1901 South Victoria, Suite 106
Oxnard, CA 93035

NV5 Office
NV5 West, Inc.
1868 Palma Drive, Suite A
Ventura, CA 93003

ATTN: Mario Mera, Sr. Program Manager

JOB DESCRIPTION AND LOCATION

OSD – Marshall E.S. New Classroom Building, 2900 Thurgood Marshall Drive, Oxnard, CA 93035
DSA No.: 03-116806, File No. 56-22

NV5 West, Inc. is currently providing DSA Class 1 Inspector of Record services on a full-time basis for the above referenced project. Our currently authorized budget of \$274,600.00 has been exceeded. It is our understanding that the project is not complete. Based upon discussion with the Project Inspector we estimate that the project will extend through August 2019. NV5 would like to request an extension of the contract through August 2019 with a contract increase of \$99,560.00.

Fee For Additional Services Described Above:

Request for extension of time and funds to complete the project.

Original Contract (DSA Class 1 Project Inspector)	= \$274,600.00
<u>Extension of Contract (through 8/30/2019)</u>	<u>= \$ 99,560.00</u>
Revised Total Contract Amount:	= \$374,160.00

OXNARD SCHOOL DISTRICT:

NV5 WEST, INC.:

BY: _____

BY:  _____

PRINT NAME & TITLE: _____

PRINT NAME & TITLE: SCOTT MOORS, VICE PRESIDENT

**OXNARD SCHOOL DISTRICT
AGREEMENT FOR CONSULTANT SERVICES
(MASTER AGREEMENT – PROJECT DSA INSPECTION [IOR])**

This Agreement for Consultant Services (“Agreement”) is entered into as of this 13th day of November, 2013 by and between the **Oxnard School District** (“District”), with offices located at 1051 South A Street, Oxnard, CA 93030, and **NOLTE - Vertical Five** (“Consultant”) with a business address at 1868 Palma Avenue, Suite D, Ventura, CA 93003. District and Consultant are sometimes hereinafter individually referred to as “Party” and hereinafter collectively referred to as the “Parties.”

RECITALS

- A. District is authorized by *California Government Code* Section 53060, and Board Policy 4368, to contract with independent contractors for the furnishing of services concerning financial, economic, accounting, engineering, legal, administrative and other matters. District has sought, by issuance of a Request for Qualifications, the performance of certain services, with the precise scope of work to be specified at the time of assignment of work.
- B. Following submission of a Statement of Qualifications for the performance of services, Consultant was prequalified by District to perform services on behalf of District that may be assigned, or not assigned, at the District’s sole discretion.
- C. The Parties desire to formalize the prequalification of Consultant for performance of services and desire that the terms of that performance be as particularly defined and described herein.

OPERATIVE PROVISIONS

NOW, THEREFORE, in consideration of the mutual promises and covenants made by the Parties and contained herein and other consideration, the value and adequacy of which are hereby acknowledged, the Parties agree as follows:

1. **Incorporation of Recitals and Exhibits.** The Recitals set forth above and all exhibits attached to this Agreement, as hereafter amended, are incorporated by this reference as if fully set forth herein.
2. **Master Agreement.** This Agreement sets forth the basic terms and conditions between District and Consultant. It may be supplemented from time to time with an individual Work Authorization Letter (“WAL”) which shall be considered an amendment to this Agreement, and which shall be subject to all the terms and conditions of this Agreement, and any further terms and conditions as set forth in the WAL.
3. **Scope of Services.** The scope of Services to be assigned to Consultant pursuant to a WAL is further defined in **Exhibit F – Scope of Services**, wherein the general responsibilities of Consultant are described pursuant to the discipline(s) for which the Consultant has been deemed prequalified by District as described in this Agreement.
4. **Agreement, Scope of Work, and Assignment of Projects.** District may, from time to time, and at the sole discretion of District, assign to Consultant specific services to be performed by Consultant (the “Services”) pursuant to a WAL. The WAL assignment procedure and associated forms are set forth in **Exhibit A**, which is attached hereto. This Agreement, together with the WAL, sets forth the terms and conditions pursuant to which Consultant will perform such Services on behalf of District. The WAL

RECEIVED NOV 01 2013 C.F.W

shall particularize and describe, among other things, such project(s) for which Consultant is to perform Services, such Services to be performed by Consultant at such project(s), the timeline for the performance of such Services, and the compensation to be paid to Consultant for the performance of such Services.

Term of Agreement. Subject to earlier termination as provided below, this Agreement shall remain in effect from November 13, 2013 through November 12, 2018 (the "Term"). This Agreement may be extended only by amendment, signed by the Parties, prior to the expiration of the Term. Such agreement for extension shall be based upon the showing of good and sufficient cause by Consultant that such extension(s) shall be granted. District shall not be obligated to compensate Consultant for any additional costs if such an extension has been granted to this Agreement. Any provision for additional compensation shall be accommodated via the WAL process as indicated in **Exhibit A**.

5. **Time for Performance.** The scope of the Services set forth in the WAL shall be completed during the Term pursuant to the schedule specified in the WAL. If Services indicated in the WAL cannot be completed within the schedule set forth in the WAL, or if the schedule exceeds the Term of this Agreement, it is the responsibility of Consultant to notify District at least ninety (90) days prior to the expiration of either, with a request for a time extension clearly identifying the cause(s) for the failure to complete the Services within the schedule and/or the Term. Should Consultant fail to provide such notice, and/or the Services not be completed pursuant to that schedule or within the Term, Consultant shall be deemed to be in Default as provided below. District, in its sole discretion, may choose not to enforce the Default provisions of this Agreement and may instead allow Consultant to continue performing the Services.
6. **Additional Services.** Additional Services are services in addition to the Services set forth in the WAL that are provided by Consultant pursuant to a written request by District. Additional Services will require a written request or pre-authorization in writing by District following specific approval of such services by the District Board of Trustees. It is understood and agreed that Consultant shall not perform any Additional Services unless and until Consultant receives specific written approval for such Additional Services from the District Board of Trustees. Any modification of the compensation to be paid to Consultant as a result of Additional Services must be specifically approved in writing by the District Board of Trustees. In the event that the District Board of Trustees approves in writing a modification of the compensation, then Consultant shall be paid for such Additional Services pursuant to Section 8, below. However, it is understood and agreed that if the cause of the Additional Services is the sole or partial responsibility of Consultant, its agents, or any subconsultants or other parties under the charge of Consultant, no additional compensation shall be paid to Consultant. If such conditions exist so as to justify Additional Services as indicated above, which require additional compensation or time in order to be performed, it is the sole responsibility of Consultant to submit a request for Additional Services within ten (10) days of Consultant's discovery of such conditions which require Additional Services. It is understood and agreed that if Consultant performs any services that it claims are Additional Services without receiving prior written approval from the District Board of Trustees, Consultant shall not be paid for such claimed Additional Services.
7. **Compensation and Method of Payment.** This Agreement does not guarantee that District will issue a WAL to Consultant nor does this Agreement guarantee any compensation to Consultant. This Agreement does not create any obligation on the part of District to compensate Consultant absent a WAL indicating compensation due to Consultant once Services are performed. Specific compensation and payment amounts, including approved reimbursable expenses, shall be set forth in the WAL. However, it is understood and agreed that the compensation to be paid to Consultant shall not be in excess of or exceed the rates set forth in **Exhibit B** "Compensation".

- a. Each month Consultant shall furnish to District an original invoice for all work performed and expenses incurred during the preceding month for Services performed pursuant to a WAL. The invoice shall clearly indicate the assigned project, the approved WAL, and shall detail charges by the following categories: labor (by sub-category), travel, materials, equipment, supplies, and sub-consultant contracts. Sub-consultant charges, if any, shall be detailed by the following categories: labor, travel, materials, equipment and supplies. District shall independently review each invoice submitted by Consultant to determine whether the work performed and expenses incurred are in compliance with the provisions of this Agreement and the WAL. In the event that no charges or expenses are disputed, the invoice shall be approved and paid according to the terms set forth in subsection b. In the event any charges or expenses are disputed by District, the original invoice shall be returned by District to Consultant for correction and resubmission.
- b. Except as to any charges for work performed or expenses incurred by Consultant which are disputed by District, District will use its best efforts to cause Consultant to be paid within forty-five (45) days of receipt of Consultant's correct and undisputed invoice.
- c. Payment to Consultant for work performed pursuant to this Agreement and a WAL shall not be deemed to waive any defects in work performed by Consultant.

8. Responsibilities of Consultant:

- a. Consultant shall perform all Services as indicated in this Agreement and the WAL to the satisfaction of District.
- b. The specific Services of Consultant to be performed shall be indicated in the WAL.
- c. Consultant hereby represents and warrants that (a) it is an experienced consultant in the discipline(s) identified in **Exhibit F**, having the skill and the legal and professional ability and the flexibility necessary to perform all of the Services required under this Agreement; (b) it has the capabilities and resources necessary to perform its obligations hereunder; (c) it is familiar with all current laws, rules, regulations and other restrictions which are and may become applicable to the scope of Services under this Agreement, including but not limited to all local ordinances, building codes, and requirements of all Authorities Having Jurisdiction (AHJ) including but not limited to the Division of State Architect (DSA), the Office of Public School Construction (OPSC), the State Facilities Planning Division (SFPD), California Department of Education (CDE), the California Department of General Services (DGS), the Department of Toxic Substances Control (DTSC), the California Environmental Quality Act (CEQA), Title 24 of the California Code of Regulations, the California Education Code, State and Local Fire Authorities, air quality districts, water quality and control boards, and any/all other AHJ; (d) that it will assume full responsibility for all Services performed and all work prepared and furnished to District by its employees, agents, and subconsultants; (e) that it has sufficient financial strength and resources to undertake and complete the Services provided for under this Agreement within the schedule set forth in the WAL; and (f) that it certifies and covenants that all reports, certifications, studies, analyses, and other documents prepared by Consultant shall be prepared in accordance with all applicable laws, rules, regulations, and other requirements in effect at the time of their preparation, or required at their time of submittal to District and or agencies.
- d. Consultant shall follow accepted industry standards and practices and comply with all federal, state, and local laws and ordinances applicable to the Services required by this Agreement and the WAL.

9. Responsibilities of District.

- a. District will prepare and furnish to Consultant upon Consultant's request, such information as is reasonably necessary to the performance of the Services required under this Agreement and the WAL. Consultant understands that all information provided to Consultant remains the property of District and shall only be removed from District's possession/premises and/or be photocopied, reproduced, distributed, or otherwise made available to others if such activities are expressly approved in writing by District and/or the Program Manager. Failure to comply with the above requirements shall be reasonable cause for termination of this Agreement, and may subject Consultant to liability for damages to District.
 - b. If needed by Consultant, District shall provide information as to the requirements and educational program for each project assigned by a WAL, including approved budget and schedule limitations.
 - c. District shall facilitate and coordinate cooperation amongst and between District consultants, including but not limited to architects, construction managers, surveyors, geotechnical engineers, inspectors, testing laboratories, hazardous materials specialists, CEQA/DTSC compliance specialists, technology experts, and any other professional consultants District deems necessary to execute the Facilities Implementation Program. Such coordination shall include the distribution of documentation prepared by individual consultants which may be of service to Consultant in the course of completing the Services.
 - d. District shall facilitate and coordinate cooperation amongst and between District staff and Consultant, as required to complete the Services.
 - e. District shall provide for the timely approval and execution of the WALs, Additional Services requests, invoices, and any other documentation that requires District action in order for Consultant to complete the Services.
10. **Suspension.** District may, for any reason or no reason, in District's sole discretion, suspend all or a portion of this Agreement, the WAL, or the Services by giving ten (10) calendar days written notice of suspension to Consultant. In the event such notice is given, Consultant shall cease immediately all work in progress. If District suspends the Services for a period of ninety (90) consecutive calendar days or more and, in addition, if such suspension is not caused by Consultant or the acts or omissions of Consultant, then if the Services are resumed, Consultant's compensation shall be subject to adjustment to provide for actual direct costs and expenses incurred by Consultant as a direct result of the suspension and resumption by District of the Services.
11. **Termination.** This Agreement, the WAL, or the Services may be terminated at any time by mutual agreement of the Parties or by either Party as follows:
- a. District may terminate all or a portion of this Agreement, the WAL, or the Services without cause at any time by giving ten (10) calendar days written notice of termination to Consultant. In the event such notice is given, Consultant shall cease immediately all work in progress; or
 - b. District may terminate all or a portion of this Agreement, the WAL, or the Services for cause in the event of a Default by giving written notice pursuant to Section 15, below; or
 - c. Consultant may terminate this Agreement or the WAL at any time upon thirty (30) calendar days written notice if District fails to make any undisputed payment to Consultant when due and such failure remains uncured for forty-five (45) calendar days after written notice to District.

12. **Similar or Identical Services.** In the event that this Agreement, the WAL, or any of the Services are terminated in whole or in part as provided herein, District may procure, upon such terms and in such manner as District may determine appropriate, services similar or identical to those terminated to complete any unfinished Services or new services as needed by District.
13. **Inspection and Final Acceptance.** District acceptance of any of work or Services, whether specifically in writing or by virtue of payment, shall not constitute a waiver of any of the provisions of this Agreement or the WAL including, but not limited to, indemnification and insurance provisions.
14. **Default.** Failure of Consultant to perform any Services or comply with any provisions of this Agreement or the WAL constitutes a Default. District may terminate all or any portion of this Agreement, the WAL, or the Services for cause in the event of a Default. The termination shall be effective if Consultant fails to cure such Default within thirty (30) calendar days following issuance of written notice thereof by District, or if the cure by its nature takes longer, fails to commence such cure within thirty (30) calendar days from the date of issuance of the notice and diligently prosecutes such cure to the satisfaction of District. If Consultant has not cured the Default, District may hold all invoices and may choose to proceed with payment on said invoices only after the Default is cured to District's satisfaction. In the alternative, District may, in its sole discretion, during the period before Consultant has cured the Default, elect to pay any portion of outstanding invoices that corresponds to Services satisfactorily rendered. Any failure on the part of District to give notice of Consultant's default shall not be deemed to result in a waiver of District's legal rights or any rights arising out of any provision of this Agreement or the WAL.
 - a. In addition to District's termination rights set forth above, District shall have (i) the right to cure Consultant's Default at Consultant's cost, in which case all amounts expended by District in connection with such cure shall accrue interest from the date incurred until repaid to District by Consultant at the rate of ten percent (10%) per annum; and (ii) all other rights and remedies available to District at law and in equity, including, without limitation, an action for damages. District shall have the right to retain unpaid earned balances to offset damages, and/or charge Consultant for all damages above and beyond unpaid balance of WAL.
15. **Ownership of Documents.** All maps, models, designs, drawings, photographs, studies, surveys, reports, data, notes, computer files, files and other documents prepared, developed or discovered by Consultant in the course of providing any Services pursuant to this Agreement or the WAL (collectively and individually, the "Documents") shall become the sole property of District and may be used, reused or otherwise disposed of by District without the permission of Consultant. Upon completion, expiration or termination of this Agreement or the WAL, Consultant shall turn over to District all such Documents.
16. **Use of Documents by District.** If and to the extent that District utilizes for any purpose not related to this Agreement or the WAL any Documents, Consultant's guarantees and warranties related to Standard of Performance under this Agreement or the WAL shall not extend to such use of the Documents.
17. **Consultant's Books and Records.** Consultant shall maintain any and all documents and records demonstrating or relating to Consultant's performance of Services pursuant to this Agreement or the WAL for a minimum of four years after termination or expiration of this Agreement and the WAL, or longer if required by law. Such records shall include at minimum a detailed record of daily performance, staff time records, subconsultants time records, documentation of all costs incurred by Consultant that were billed to District, and detailed records of all Consultant fees, overhead, and profit on earned amounts.

a. Consultant shall maintain any and all ledgers, books of account, invoices, vouchers, canceled checks, or other documents or records evidencing or relating to work, services, expenditures and disbursements charged to District pursuant to this Agreement or the WAL for a minimum of four years, or longer if required by law, all in accordance with generally accepted accounting principles and with sufficient detail so as to permit an accurate evaluation of the Services provided by Consultant pursuant to this Agreement or the WAL.

b. Any and all such records or documents shall be made available for inspection, audit and copying, at any time during regular business hours, upon request by District or its designated representative. Copies of such documents or records shall be provided directly to District for inspection, audit and copying when it is practical to do so; otherwise, unless an alternative is mutually agreed upon, such documents and records shall be made available at Consultant's address indicated for receipt of notices in this Agreement.

c. District has the right to acquire custody of such records by written request if Consultant decides to dissolve or terminate its business. Consultant shall deliver or cause to be delivered all such records and documents to District within sixty (60) days of receipt of the request.

18. **Independent Contractor.** Consultant is retained as an independent contractor and is not employed by District. No employee or agent of Consultant shall become, or be considered to be, an employee of District for any purpose. It is agreed that District is interested only in the results obtained from the Services under this Agreement and the WAL and that Consultant shall perform as an independent contractor with sole control of the manner and means of performing the Services required under this Agreement and the WAL. Consultant shall complete this Agreement and the WAL according to its own methods of work which shall be in the exclusive charge and control of Consultant and which shall not be subject to control or supervision by District except as to results of the Services. Consultant shall provide all of its own supplies, equipment, facilities, materials, manpower, and any/all other resources that may become necessary in the course of completing the Services. It is expressly understood and agreed that Consultant and its employees shall in no event be entitled to any benefits to which District employees are entitled, including, but not limited to, overtime, retirement benefits, insurance, vacation, worker's compensation benefits, sick or injury leave or other benefits. Consultant will be responsible for payment of all of Consultant's employees' wages, payroll taxes, employee benefits and any amounts due for federal and state income taxes and Social Security taxes since these taxes will not be withheld from payments under this Agreement or the WAL.

a. The personnel performing the Services under this Agreement and the WAL on behalf of Consultant shall at all times be under Consultant's exclusive direction and control. Consultant, its agents or employees shall not at any time or in any manner represent that Consultant or any of Consultant's officers, employees, or agents are in any manner officials, officers, employees or agents of District.

b. Consultant shall have no authority to bind District in any manner, or to incur any obligation, debt or liability of any kind on behalf of or against District, whether by contract or otherwise, unless such authority is expressly conferred in writing by District, or under this Agreement.

19. **Standard of Performance.** Consultant represents and warrants that it has the skill, qualifications, experience and facilities necessary to properly perform the Services required under this Agreement and the WAL in a thorough, competent and professional manner. Consultant represents and warrants that its employees and subcontractors have all legally required licenses, permits, qualifications and approvals necessary to perform the Services and that all such licenses and approvals shall be maintained throughout the term of this Agreement and the WAL. Consultant shall at all times faithfully, competently and to the best of its ability, experience and talent, perform all Services

described herein and the WAL. In meeting its obligations under this Agreement and the WAL, Consultant shall employ, at a minimum, the standard of care utilized by persons engaged in providing services similar to those required of Consultant under this Agreement and the WAL for California school districts in or around the same geographic area of District (the "Standard of Performance").

20. **Confidential Information.** All information gained during performance of the Services and all Documents or other work product produced by Consultant in performance of this Agreement and the WAL shall be considered confidential ("confidential information"). Consultant shall not release or disclose any such confidential information, Documents or work product to persons or entities other than District without prior written authorization from the Superintendent of District and/or Program Manager, except as may be required by law. Confidential information does not include information that: (i) Consultant had in its possession prior to considering entering into this Agreement; (ii) becomes public knowledge through no fault of Consultant; (iii) Consultant lawfully acquires from a third party not under an obligation of confidentiality to the disclosing party; or (iv) is independently developed by Consultant without benefit of the information provided by District. In connection with confidential information:

a. Consultant shall promptly notify District if it is served with any summons, complaint, subpoena or other discovery request, court order or other request from any party regarding this Agreement or the WAL or the Services performed hereunder or the WAL.

b. District retains the right, but has no obligation, to represent Consultant or be present at any deposition, hearing or similar proceeding. Consultant agrees to cooperate fully with District and to provide District with the opportunity to review any response to discovery requests provided by Consultant; provided that this does not imply or mean the right by District to control, direct, or rewrite said response.

21. **Conflict of Interest; Disclosure of Interest.** Consultant covenants that neither it, nor any officer or principal of its firm, has or shall acquire any interest, directly or indirectly, which would conflict in any manner with the interests of District or which would in any way hinder Consultant's performance of the Services under this Agreement or the WAL. Consultant further covenants that in the performance of this Agreement and the WAL, no person having any such interest shall be employed by it as an officer, employee, agent or subcontractor without the express written consent of District. Consultant agrees to at all times avoid conflicts of interest or the appearance of any conflicts of interest with the interests of District in the performance of this Agreement and the WAL.

a. Bylaws of the Board 2030(A) E, 2030(B) E and 2030(C) E, as hereinafter amended or renumbered, require that a consultant that qualifies as a "designated employee" must disclose certain financial interests by filing financial interest disclosures. By its initials below, Consultant (i) represents that it has received and reviewed a copy of the Bylaws of the Board 2030(A) E, 2030(B) E and 2030(C) E and that it does does not qualify as a "designated employee"; and (ii) agrees to notify District, in writing, if Consultant believes that it is a "designate employee" and should be filing financial interest disclosures, but has not been previously required to do so by District.

 (Initials)

22. **Compliance with Applicable Laws.** In connection with the Services and its operations, Consultant shall keep itself informed of and comply with all applicable federal, state and local laws, statutes, codes, ordinances, regulations and rules including, but not limited to, minimum wages and/or prohibitions against discrimination, in effect during the Term. Consultant shall obtain any and all licenses, permits and authorizations necessary to perform the Services. Neither District, nor any

elected or appointed boards, officers, officials, employees or agents of District shall be liable, at law or in equity, as a result of any failure of Consultant to comply with this section.

a. Without limiting the generality of the foregoing, Consultant, unless exempted, shall comply with the requirements of Education Code Section 45125.1 with respect to fingerprinting of employees who may have contact with District's pupils. Consultant must complete District's certification form, attached herein as Exhibit E, prior to any of Consultant's employees coming into contact with any of District's pupils. Consultant also agrees to comply with all other operational requirements of District, as may be revised from time to time, including but not limited to any obligations relating to vaccination or testing for infectious diseases.

 (Initials)

23. **Unauthorized Aliens.** Consultant hereby promises and agrees to comply with all of the provisions of the Federal Immigration and Nationality Act, 8 U.S.C.A. §§ 1101, et seq., as amended, and in connection therewith, shall not employ "unauthorized aliens" as that term is defined in 8 U.S.C.A. §1324a(h)(3). Should Consultant so employ such individuals for the performance of work and/or Services covered by this Agreement or the WAL, and should any liability or sanctions be imposed against District for such employment, Consultant hereby agrees to and shall reimburse District for the cost of all such liabilities or sanctions imposed, together with any and all costs, including attorneys' fees, incurred by District.
24. **Non-Discrimination.** Consultant shall abide by the applicable provisions of the United States Civil Rights Act of 1964 and other provisions of law prohibiting discrimination and shall not discriminate, in any way, against any person on the basis of race, color, religious creed, national origin, ancestry, sex, sexual orientation, age, physical handicap, medical condition or marital status in connection with or related to the performance of this Agreement or the WAL.
25. **Disabled Veteran Business Enterprise Participation.** Pursuant to Education Code section 17076.11, District has a participation goal for disabled veteran business enterprises (DVBES) of at least three (3) percent, per year, of funds expended each year by District on projects that use funds allocated by the State Allocation Board pursuant to the Leroy F. Greene School Facilities Act. Unless waived in writing by District, Consultant shall provide proof of DVBE compliance, in accordance with any applicable policies of District or the State Allocation Board, within thirty (30) days of its execution of this Agreement
26. **Assignment.** The expertise and experience of Consultant are material considerations for this Agreement and the WAL. District has an interest in the qualifications of and capability of the persons and entities that will fulfill the duties and obligations imposed upon Consultant under this Agreement and the WAL. In recognition of that interest, Consultant shall not assign or transfer this Agreement or any portion of this Agreement or any portion of the WAL or the performance of any of Consultant's duties, Services or obligations under this Agreement or the WAL without the prior written consent of District and approved by District's Board of Trustees. Any attempted assignment shall be ineffective, null and void, and shall constitute a material breach of this Agreement and the WAL entitling District to any and all remedies at law or in equity, including summary termination of this Agreement and the WAL.
27. **Subcontracting.** Notwithstanding the above, Consultant may utilize subcontractors in the performance of its duties pursuant to this Agreement and the WAL, but only with the prior written consent of District. Consultant shall be as fully responsible to District for the acts and omissions of its subcontractors, and of persons either directly or indirectly employed by Consultant's subcontractors, as if the acts and omissions were performed by Consultant directly.

28. **District Administrator.** Lisa Franz shall be in charge of administering this Agreement on behalf of District, (the “Administrator”) provided that any written notice or any consent, waiver or approval of District must be signed by the Superintendent or a designated employee of District to be valid. The Administrator has completed Exhibit D “Conflict of Interest Check” attached hereto.

29. **Continuity of Personnel.** Consultant shall make every reasonable effort to maintain the stability and continuity of Consultant’s staff and subcontractors consistent with the staff proposed as part of the Statement of Qualifications, if any, assigned to perform Services under this Agreement and the WAL.

a. Consultant shall provide District and the Administrator a list of all personnel and subcontractors providing Services and shall maintain said list current and up to date at all times during the Term. The list shall include the following information: (1) all full or part-time staff positions by title, including volunteer positions whose direct services are required to provide the Services; (2) a brief description of the functions of each such position and the hours each position works each week or, for part-time positions, each day or month, as appropriate; (3) the professional degree, if applicable, and experience required for each position; and (4) the name of the person responsible for fulfilling the terms of this Agreement and the WAL.

30. **Indemnification.** To the fullest extent permitted by law, Consultant shall defend and indemnify District and its officials, elected board members, employees and agents (“Indemnified Parties”) from and against all claims that arise out of, pertain to, or relate to the negligence, recklessness, or willful misconduct of the Consultant, its officers, employees, consultants, subcontractors, or agents, pursuant to this Agreement and/or the WAL, but not for any loss, injury, death or damage caused by the active negligence or willful misconduct of any of the Indemnified Parties.

a. Consultant agrees to obtain executed indemnity agreements with provisions identical to the above from each and every subcontractor retained or employed by Consultant in the performance of this Agreement and the WAL. Failure of District to monitor compliance with these requirements imposes no additional obligations on District and will in no way act as a waiver of any rights hereunder. Consultant’s obligation to indemnify and defend District as set forth above is binding on the successors, assigns or heirs of Consultant and shall survive the termination of this Agreement and the WAL.

 (Initials)

31. **Insurance.** Consultant agrees to obtain and maintain in full force and effect during the term of this Agreement the insurance policies set forth in Exhibit C “Insurance” and made a part of this Agreement. All insurance policies shall be subject to approval by District as to form and content. These requirements are subject to amendment or waiver if so approved in writing by the District Superintendent.

32. **Notices.** All notices required or permitted to be given under this Agreement or the WAL shall be in writing and shall be personally delivered, or sent by telecopier or certified mail, postage prepaid and return receipt requested, addressed as follows:

To District: Oxnard School District
1051 South A Street
Oxnard, California, 93030
Attention: Lisa Cline
Assistant Superintendent, Business & Fiscal Services
Re: [Insert Project Name]

With electronic copy to: Caldwell Flores Winters, Inc.
Oxnard School District Program Manager
6425 Christie Ave., Suite 270
Emeryville, California 94608
Attention: Yuri Calderon
T: 510-596-8170
Email: ycalderon@cfwinc.com

To Consultant: NOLTE – Vertical Five (NV5)
1868 Palma Drive, Suite A
Ventura, CA 93003
Attention: Scott Moors
T: (805) 656-6074
Email: scott.moors@nv5.com

All notices, demands, or requests to be given under this Agreement or the WAL shall be given in writing and conclusively shall be deemed received when delivered in any of the following ways: (i) on the date delivered if delivered personally; (ii) on the date sent if sent by facsimile transmission and confirmation of transmission is received; (iii) on the date it is accepted or rejected if sent by certified mail; and (iv) the date it is received if sent by regular United States mail.

33. **Excusable Delays.** Neither Party will be liable to the other for unanticipated delays or failures in performance resulting from causes beyond the reasonable control of that Party, including, but not limited to, acts of God, labor disputes or disturbances, material shortages or rationing, riots, acts of war, governmental regulations, communications or utility failures, or casualties; provided that the delayed Party: (i) gives the other Party prompt written notice of such cause; and (ii) uses its reasonable efforts to correct such failure or delay in its performance. The delayed Party's time for performance or cure under this section will be extended for a period equal to the duration of the cause or sixty (60) days, whichever is less.
34. **Entire Agreement; Binding Effect.** This Agreement including Exhibits hereto, contains the entire understanding of the Parties, and supersedes all other written or oral agreements. Consultant shall be entitled to no other benefits other than those specified herein. No changes, amendments or alternations shall be effective unless in writing and signed by both Parties and approved by District's Board of Trustees. Consultant specifically acknowledges that in entering into this Agreement, Consultant relied solely upon the provisions contained in this Agreement and no others. This Agreement shall be binding upon the heirs, executors, administrators, successors and assigns of the Parties.
35. **Amendment.** No changes, amendments to or modifications of this Agreement or the WAL shall be valid, effective or binding unless made in writing and signed by both Parties and approved by the District's Board of Trustees. The Parties agree that this requirement for written modifications cannot be waived and that any attempted waiver shall be void.
36. **Waiver.** Waiver by any Party of any term, condition, or covenant of this Agreement or the WAL shall not constitute a waiver of any other term, condition, or covenant. Waiver by any Party of any breach of the provisions of this Agreement or the WAL shall not constitute a waiver of any other provision or a waiver of any subsequent breach or violation of any provision of this Agreement or the WAL. None of the provisions of this Agreement or the WAL shall be considered waived by either Party unless such waiver is specifically specified in writing. Neither District's review, approval of, nor payment for, any of the Services required under this Agreement or the WAL shall be construed to operate as a waiver of

any rights under this Agreement or the WAL, and Consultant shall remain liable to District in accordance with this Agreement and the WAL for all damages to District caused by Consultant's failure to perform any of the Services to the Standard of Performance. This provision shall survive the termination of this Agreement and the WAL.

37. **Governing Law.** This Agreement and the WAL shall be interpreted, construed and governed according to the laws of the State of California. With respect to litigation involving this Agreement, the WAL or the Services, venue in state trial courts shall lie exclusively in the County of Ventura, California.

38. **Severability.** If any term, condition or covenant of this Agreement or the WAL is declared or determined by any court of competent jurisdiction to be invalid, void or unenforceable, the remaining provisions of this Agreement and the WAL shall not be affected thereby and the Agreement and WAL shall be read and construed without the invalid, void or unenforceable provision(s).

39. **Authority to Execute.** The person or persons executing this Agreement on behalf of Consultant represents and warrants that he/she/they has/have the authority to so execute this Agreement and to bind Consultant to the performance of its obligations hereunder.

IN WITNESS WHEREOF, District and Consultant have executed and delivered this Agreement for consultant services as of the date first written above.

OXNARD SCHOOL DISTRICT:

NOLTE-VERTICAL FIVE:

Lisa A. Franz
Signature

Scott Moors
Signature

Lisa A. Franz, Director, Purchasing
Typed Name/Title

Scott Moors / Vice President
Typed Name/Title

11-20-13
Date

10-30-13
Date

Tax Identification Number: 95-6002318

Tax Identification Number: 94-2706173

- Not Project Related
 Project #13-130

EXHIBIT A
TO AGREEMENT FOR CONSULTANT SERVICES #13-130

WORK AUTHORIZATION PROCEDURES

1. Assignment of Work Authorization

- 1.1. **Request For Proposal (RFP):** At the sole discretion of District, one or more prequalified professional services consultants shall be solicited with a Request For Proposal (“RFP”) for a specific lump sum fixed fee proposal for defined Services to be complete within a defined timeline. For a proposal to be valid it must clearly acknowledge the complete Services requested by District and must include a lump sum fixed fee amount to complete all defined Services, a clearly defined schedule for completion of Services which meets the required timeline defined by District and shows final completion to occur within the Term of this Agreement.
- 1.2. **Evaluation of Proposal:** District’s Program Manager, in consultation with District, shall review each proposal for validity, accuracy, competitiveness, and overall quality of the Services proposed to be performed. In the case where more than one firm is solicited for a scope of defined Services, the Program Manager shall evaluate each proposal thoroughly based on predetermined, objective criteria to ensure a just and fair review of all proposals.
- 1.3. **Selection of Consultant:** Following evaluation of proposals, the consultant whose proposal exhibits the best value for the benefit of District shall be recommended to the Superintendent for approval.
- 1.4. **Work Authorization Letter (WAL):** With the approval of the District Superintendent, the Program Manager shall issue a Work Authorization Letter (“WAL”) to the selected consultant to perform the defined Services as indicated in the RFP, for the lump sum fixed fee amount reflected in the proposal, with all Services to complete within the timeline indicated in the RFP, and the Term set forth in this Agreement. District retains the right to negotiate all terms of the WAL subsequent to the receipt of proposal(s) in order to clarify the scope of Services, and/or make any adjustments to the fee amount and required schedule prior to issuance of the WAL. The WAL shall be considered a binding agreement, and amendment to this Agreement, once executed by Consultant, approved by the District Board of Trustees, and executed by the Superintendent.
- 1.5. **Performance of Services Set Forth in the WAL:** Performance of Services set forth in the WAL shall not commence until final approval by the District Superintendent and Board of Trustees, unless expressly authorized by the District Superintendent and Program Manager. During the course of completing the Services, Consultant shall comply with all provisions of this Agreement and the WAL. All Services set forth in the WAL shall be completed within the schedule set forth in the WAL.
- 1.6. **Close Out of WAL Services:** Upon completion of all Services required by the WAL, Consultant shall submit all required close-out documentation, certifications, records, reports, warranties, and any other information required or requested by District prior to submitting Consultant’s invoice for final payment.
- 1.7. **WAL Form:** See next page for sample Work Authorization Letter.

- Not Project Related
- Project #13-130

	WORK AUTHORIZATION LETTER (WAL)	
	GENERAL INFORMATION	
	PROJECT #:	DATE:
	SITE NAME:	DSA #:
MASTER AGREEMENT #:	OPSC #:	
WAL #:	VENDOR ID:	
PURSUANT TO MASTER AGREEMENT BETWEEN:		
DISTRICT	CONSULTANT	
OXNARD SCHOOL DISTRICT 1051 South A. St. Oxnard , CA 93030 (805) 385-1501	Firm Name: Street: City, State, Zip: Phone:	
SCOPE OF SERVICES TO BE PERFORMED UNDER THIS WAL		
(ATTACH ADD'L PAGES AS NECESSARY)		
SCHEDULE OF SERVICES TO BE PERFORMED UNDER THIS WAL		
START DATE:		COMPLETION DATE:
FIXED FEE AMOUNT: _____		
<p><i>This fee amount is based upon Consultant's proposal dated _____, and subsequent negotiations mutually agreed to by all parties.</i></p> <p><i>This WAL is inherently a part of the Master Agreement indicated above. It is bound by the general terms and conditions of the Master Agreement. This WAL describes in detail the Consultants specific scope of Services, agreed upon lump sum fixed fee, agreed upon schedule for completion of Services, and other provisions required to clearly indicate the required Services, and terms of this WAL.</i></p> <p><i>This WAL and associated Master Agreement hereby supersede any and all terms, conditions, and other provisions of the Consultant's proposal, and such terms, conditions, and other provisions are null and void and are not incorporated to any extent as part of this WAL and associated Master Agreement whether or not they are directly superseded by this WAL and/or the associated Master Agreement.</i></p> <p>IN WITNESS THEREOF, THE PARTIES HAVE AGREED TO AND EXECUTED THIS WAL AS SET FORTH BELOW:</p>		
DISTRICT	CONSULTANT	
OXNARD SCHOOL DISTRICT _____ (SIGNATURE)	CONSULTANT: _____ (SIGNATURE)	
_____ (DATE)	_____ (DATE)	
FOR DISTRICT USE ONLY		
PROJECT MANAGER:	PREPARED BY:	
PO #:	PO AMOUNT:	
SOURCE OF FUNDS:	<input type="checkbox"/> MEASURE "R" <input type="checkbox"/> DEF. MAINT. <input type="checkbox"/> DEV. FEES <input type="checkbox"/> OTHER: _____	
COST ID:		
_____ (PM APPROVAL SIGNATURE)		
_____ (DATE)		
SPECIAL INSTRUCTIONS:		

- Not Project Related
 Project #13-130

EXHIBIT B
TO AGREEMENT FOR CONSULTANT SERVICES #13-130

COMPENSATION & RATE/FEE SCHEDULE

I. The following rates of pay shall apply in the performance of the Services under this Agreement and the WAL:

PROJECT DSA INSPECTIONS FEE SCHEDULE

NOLTE – Vertical Five is pleased to present Fee Schedule for Project Inspection Services for the Oxnard School District.

<u>Classification</u>	<u>Hourly Rate</u>
1. DSA Class 1 Project Inspector	\$ 85
2. DSA Class 2 Project Inspector	\$ 80
3. DSA Class 3 Project Inspector	\$ 75

II. Consultant may utilize subcontractors as permitted in the Agreement and the WAL. The hourly rate for any subcontractor shall be consistent with the rate and fee schedule indicated in Section I above, unless other direction is provided with written authorization from District Superintendent or his/her designee.

III. Claims for reimbursable expenses shall be documented by appropriate invoices and supporting receipts. Consultant may be reimbursed for those reasonable out-of-pocket expenses set forth below that are incurred and paid for by Consultant beyond the typical obligations under this Agreement and the WAL, but only to the extent that such expenses are directly related to Services satisfactorily completed, are approved by District in writing and do not cause the amounts paid to Consultant to exceed the amounts allowed under this Agreement and the WAL. No mark-up of any expense is permitted. The following is the EXCLUSIVE list of reimbursable expenses:

A. Travel and Mileage. Consultant must request the travel in writing and justify why the travel should be reimbursed. Travel expenses must be approved in writing by District, in its sole discretion. Trips from any Consultant’s office to District’s office or to the subject project site will not be approved for reimbursement.

B. Reimbursable Reprographic Services. Print sets or copies requested in writing by District beyond the quantities required under the WAL.

C. Fees for Subcontractors. Fees for subcontractors hired and paid by Consultant at the written request of District and are permitted in the Agreement and the WAL.

D. Fees advanced for securing approval of public agencies having jurisdiction over any project hereunder.

Not Project Related

Project #13-130

IV. Consultant shall provide to District a complete Schedule of Values (SOV), identifying major work activities required to complete the authorized scope of work. All invoices must reflect the appropriate progress percentage for each SOV item billed, to be verified by District. District will compensate Consultant for the Services performed upon approval by District of a valid and complete invoice, in form and substance acceptable to District. See Exhibit G for required Invoice Approval Form and Billing Cover Sheet. The Billing Cover Sheet shall reflect the approved SOV. In connection with Services that are only partially completed at the time an invoice is paid, notwithstanding any provision of the Agreement, the WAL, or any other document, payment of the invoice does not constitute acceptance of the partially completed work or Service. Each invoice is to include:

- A. Billing Cover Sheet/SOV with all appropriate progress percentages identified toward completion of the Services.
- B. Acceptable back-up for billings shall include, but not be limited to:
 - a. Records for all personnel describing the work performed, the number of hours worked, and the hourly rate, for all time charged to the Services.
 - b. Records for all supplies, materials and equipment properly charged to the Services.
 - c. Records for all travel pre-approved by District and properly charged to the Services.
 - d. Records for all subcontractor labor, supplies, equipment, materials, and travel properly charged to the Services.

Unless otherwise directed by District, in writing, completed invoices are to be submitted to the attention of the Director of Purchasing and the Assistant Superintendent, Business and Fiscal Services. To be considered complete, the invoice packet shall include all back-up documentation required by District and sign-off from District staff, Program Manager or project manager assigned by District to supervise the Services.

V. The total compensation for the Services shall be provided for in the WAL(s) issued subsequent to this Agreement.

VI. Compensation Upon Termination. In the event that District suspends or terminates this Agreement, the WAL or any of the Services pursuant to Section 11 or Section 12a of the Agreement, District will pay Consultant as provided herein and the WAL for all Services and authorized Additional Work actually performed, and all authorized reimbursable expenses actually incurred and paid, under and in accordance with this Agreement and the WAL, up to and including the date of suspension or termination; provided that such payments shall not exceed the amounts specified in the Agreement and the WAL as compensation for the Services completed, plus any authorized Additional Work and authorized reimbursable expenses completed prior to suspension or termination. No payment for demobilization shall be paid unless District at its sole discretion determines that demobilization or other compensation is appropriate. After a notice of termination is given, Consultant shall submit to District a final claim for payment, in the form and with certifications prescribed by District. Such claim shall be submitted promptly, but in no event later than forty (40) calendar days after the Termination Date specified on the notice of termination. Such payment shall be Consultant's sole and exclusive compensation and District shall have no liability to Consultant for any other compensation or damages, including without limitation, anticipated profit, prospective losses, legal fees or costs associated with legal representation or consequential damages, of any kind.

- Not Project Related
- Project #13-130

EXHIBIT C
TO AGREEMENT FOR CONSULTANT SERVICES #13-130

INSURANCE

I. **Insurance Requirements.** Consultant shall provide and maintain insurance, acceptable to District Superintendent or District Counsel, in full force and effect throughout the Term of this Agreement and the WAL, against claims for injuries to persons or damages to property which may arise from or in connection with the performance of the work hereunder by Consultant, its agents, subcontractors, representatives and/or employees. Insurance is to be placed with insurers authorized to conduct business in the State of California and with a current A.M. Best's rating of no less than A, as rated by the current edition of Best's Key Rating Guide, published by A.M. Best Company, Oldwick, New Jersey 08858. Consultant shall provide the following scope and limits of insurance:

A. **Minimum Scope of Insurance.** Coverage shall be at least as broad as:

- (1) Commercial General Liability coverage of not less than two million dollars (\$2,000,000) aggregate and one million dollars (\$1,000,000) per occurrence.
- (2) Auto liability insurance with limits of not less than one million dollars (\$1,000,000).
- (3) Insurance coverage should include:
 - 1. owned, non-owned and hired vehicles;
 - 2. blanket contractual;
 - 3. broad form property damage;
 - 4. products/completed operations; and
 - 5. personal injury.
- (4) Workers' Compensation insurance as required by the laws of the State of California.
- (5) Abuse and Molestation coverage of not less than two million dollars (\$2,000,000) per occurrence and five million dollars (\$5,000,000) aggregate.
- (6) Professional liability (Errors and Omissions) insurance, including contractual liability, as appropriate to the Consultant's profession, in an amount of not less than the following:

Accountants, Attorneys, Education Consultants, Nurses, Therapists	\$1,000,000
Architects	\$1,000,000 or \$2,000,000
Physicians and Medical Corporations	\$5,000,000

Failure to maintain professional liability insurance is a material breach of this Agreement and the WAL and grounds for immediate termination

II. **Other Provisions.** Insurance policies required by this Agreement shall contain the following provisions:

Not Project Related

Project #13-130

A. All Policies. Each insurance policy required by this Agreement shall be endorsed and state the coverage shall not be suspended, voided, cancelled by the insurer or either Party to this Agreement, reduced in coverage or in limits except after 30 days' prior written notice by Certified mail, return receipt requested, has been given to District

B. General Liability, Automobile Liability, and Abuse/Molestation Coverages.

(1) District, and its respective elected and appointed officers, officials, employees and volunteers are to be covered as additional insureds (collectively, "additional insureds") as respects the following: liability arising out of activities and/or Services Consultant performs; products and completed operations of Consultant; premises owned, occupied or used by Consultant; automobiles owned, leased, hired or borrowed by Consultant, and Abuse/Molestation. The coverage shall contain no special limitations on the scope of protection afforded to additional insureds.

(2) Each policy shall state that the coverage provided is primary and any insurance carried by any additional insured is in excess to and non-contributory with Consultant's insurance.

(3) Consultant's insurance shall apply separately to each insured against whom claim is made or suit is brought, except with respect to the limits of the insurer's liability.

(4) Any failure to comply with the reporting or other provisions of the policies including breaches of warranties shall not affect coverage provided to any additional insured.

III. Other Requirements. Consultant agrees to deposit with District, at or before the effective date of this Agreement and the WAL, certificates of insurance necessary to satisfy District that the insurance provisions of this Agreement have been complied with. District may require that Consultant furnish District with copies of original endorsements effecting coverage required by this section. The certificates and endorsements are to be signed by a person authorized by that insurer to bind coverage on its behalf. District reserves the right to inspect complete, certified copies of all required insurance policies, at any time.

A. If any Services are performed by a subcontractor, Consultant shall furnish certificates and endorsements from each subcontractor identical to those Consultant provides.

B. Any deductibles or self-insured retentions must be declared to and approved by District. At the option of District, either the insurer shall reduce or eliminate such deductibles or self-insured retentions as respects District or its respective elected or appointed officers, officials, employees and volunteers or the Consultant shall procure a bond guaranteeing payment of losses and related investigations, claim administration, defense expenses and claims.

C. The procuring of any required policy or policies of insurance shall not be construed to limit Consultant's liability hereunder nor to fulfill the indemnification provisions and requirements of this Agreement.

- Not Project Related
- Project #13-130

EXHIBIT D
TO AGREEMENT FOR CONSULTANT SERVICES #13-130

CONFLICT OF INTEREST CHECK

Bylaws of the Board 2030(C)E requires that the Superintendent or a designee make a determination, on a case by case basis, concerning whether disclosure will be required from a consultant to comply with District's Conflict of Interest Code (commencing with Bylaws of the Board 2030 BB).

Consultants are required to file disclosures when, pursuant to a contract with District, Consultant will make certain specified government decisions or will perform the same or substantially the same duties for District as a staff person would.

The services to be performed by Consultant under the Agreement to which this Exhibit D is attached constitute do not constitute governmental decisions or staff services within the meaning of the Conflict of Interest Code. Therefore, Consultant, is is not subject to disclosure obligations.

Date: 11-20-13

By: 
Lisa A. Franz
Director, Purchasing

Not Project Related

Project #13-130

**EXHIBIT “E”
TO AGREEMENT FOR CONSULTANT SERVICES #13-130**

**BACKGROUND CHECK AND FINGERPRINTING PROCEDURES
FOR CONTRACTORS**

The successful Bidder will be required to assure that its employees, subcontractors of any tier, material suppliers, and consultants do not have direct contact with the District’s students during the performance of the Contract in compliance with Education Code §§ 45125.1 and 45125.2. To assure these provisions, the successful Bidder’s supervisor shall be fingerprinted, and proof of same shall be provided to the District prior to start of on-site work. The supervisor will monitor the workers’ conduct while on school grounds. In addition, the successful Bidder shall barricade the Work area to separate its workers from the students. Costs associated with this process are the responsibility of the successful Bidder.

The Contractors’ construction supervisors or their unsupervised employees who will be working outside of fenced areas during the school hours **must** have submitted a fingerprint identification card to the Department of Justice (DOJ) and have a proof of clearance in the form of an affidavit filed in the Oxnard School District’s Purchasing Office **prior to** the start of the Work.

California Education Code §§45125.1 and 45125.2 require that criminal checks be completed for contractors (Contracting Firm) who provide architectural, construction, janitorial, administrative, landscape, transportation, food-related, or other similar services to school districts.

The undersigned does hereby certify to the Board of Trustees of the Oxnard School District as follows:

That I am a representative of the Contractor currently under contract (“Contract”) with the District; that I am familiar with the facts herein certified, and am authorized and qualified to execute this certificate on behalf of Contractor.

Contractor certifies that it has taken the following actions with respect to the construction Project that is the subject of the Contract:

1. Pursuant to Education Code §45125.2, Contractor has installed or will install, prior to commencement of Work, a physical barrier at the Work Site, which will limit contact between Contractor’s employees and District pupils at all times (mandatory for all Projects); AND
2. The Contractor has complied with the fingerprinting requirements of Education Code §45125.1 with respect to all Contractor’s employees and all of its subcontractors’ employees who may have contact with District pupils in the course of providing services pursuant to the Contract, and the California Department of Justice has determined that none of those employees has been convicted of a felony, as that term is defined in Education Code §45122.1. A complete and accurate list of Contractor’s employees and of all its subcontractors’ employees who may come in contact with District pupils during the course and scope of the Contract is attached hereto; AND/OR

- Not Project Related
- Project #13-130

3. Pursuant to Education Code §45125.2, Contractor certifies that all employees will be under the continual supervision of, and monitored by, an employee of the Contractor who the California Department of Justice has ascertained has not been convicted of a violent or serious felony. The name and title of each employee who will be supervising Contractor's employees and its subcontractors' employees is:

Name: Scott Moors

Title: Vice President

AND/OR

4. The Work on the Contract is at an unoccupied school site and no employee and/or subcontractor or supplier of any tier of Contract shall come in contact with District pupils.

Contractor's responsibility for background clearance extends to all of its employees, Subcontractors, and employees of Subcontractors coming into contact with District pupils regardless of whether they are designated as employees or acting as independent contractors of the Contractor.

Date: 10-30-13

Proper Name of Contractor: Nolte - Vertical Five

Signature: 

By: Scott Moors

Its: _____

- Not Project Related
 Project #13-130

EXHIBIT "F"
TO AGREEMENT FOR CONSULTANT SERVICES #13-130

SCOPE OF SERVICES – PROJECT DSA INSPECTION (IOR)

The Project Inspector's Scope of Work includes, but is not limited to, the following:

Consultant shall ensure that the work performed in the field is in accordance with DSA approved design documents. The project inspector will be required to monitor all construction activities, review RFIs, change orders, and submittals, and to confirm that construction activities were performed satisfactorily in accordance with approved design.

1. Certifications:

- a. Possession and maintenance in good standing of all classes of licensed DSA Project Inspectors' Certificate issued by the Division of the State Architect.

2. Pre-Construction services required:

- a. Familiarity with the project scope and approved drawings and specifications.
- b. Preparation of all required forms for DSA, the Architect and the District.
- c. Participation at all preconstruction meetings.

3. Construction Phase Services Required:

- a. Performance of project inspection in accordance with Sections 4-211, 4-333 and 4-341, Title 24 Part 1, 2010 California Building Standards Administrative Code, Division of State Architect requirements, and all other laws, codes, and regulations governing educational facilities construction inspection.
- b. Daily site inspections with reports to inform Contractor, Architect, District and DSA of non-conforming work and corrective steps required.
- c. Monitoring of daily construction progress relating to the construction schedule, T & M work required, weather delays and like activities.
- d. Verification that all required materials sampling and special inspections are coordinated with construction activities, performed in accordance with project requirements and properly documented.
- e. Tracking of Record Drawing updates by the Contractor.
- f. Prompt filing of all periodic reports required during the construction process.
- g. Attendance at periodic job meetings and visits by DSA and District personnel.
- h. Review of Requests for Information generated by the Contractor.
- i. Observe and document discovered conditions and inform Contractor, Architect and District of such conditions.
- j. Review of periodic pay requests generated by the Contractor.
- k. Review of proposed change orders to verify that such work falls outside of the project scope.

4. Post-Construction Services Required:

- a. Compilation of operations and maintenance manuals, warranties/guarantees, and certificates.
- b. Compilation and completion of all documentation to assure DSA close-out with certification.

- Not Project Related
 Project #13-130

5. Reports

As part of the Services, Consultant will prepare and deliver the following tangible work products to District:

- a. All DSA required inspections, reporting, processes and procedures required by the DSA Testing & Inspection Listing, and/or required by the Architect of Record.

6. Time

All DSA required reporting shall be delivered to the District concurrent with the submittal to DSA, and pursuant to DSA required timelines. The final inspection report (DSA Form 6) shall be completed and electronic filed within 30 calendar days of the notice of completion.

7. Accuracy Standards

Precision of the inspection reports and other documentation shall be in accordance with the professional standard of care to be expected of professional DSA inspectors licensed to practice in the State of California.

- Not Project Related
 Project #13-130

Consultant/Vendor Billing Instructions

Invoice Cover Sheet Set-Up.

- 1 See "billing tab" below for spreadsheet, these are the instructions
 - 2 Enter Project Site name, DSA project number, Project Type, Invoice #, Date, Your Company Name, fax, phone, etc....
 - 3 Enter PO # (Purchase Order #) provided to you when contract issued.
 - 4 Feel free to include your company logo if you wish
 - 5 Enter approved contract agreements, amendments, re-imbursables, allowances, etc. for which you are billing. Include summary scope of work. Enter "Cost Code" provided to you by Program Manager.
 - 6 If you wish to break the contract work items down into portions that you would typically separate for progressive payments, please do that now. If your contract allows re-imbursables in addition to contract fee, please separate these values. If you require more line items to complete this step, please highlight the entire last row by clicking on the grey row # at left, press CTRL+C to copy row, right click grey row # immediately below, select "Insert Copied Cells". This can be repeated as many times as necessary. Multiple rows can be copied/inserted in a single step by highlighting multiple rows prior to copying.
- First Billing**
- 5 **IMPORTANT!** When you are entering costs for your first billing, enter values (dollar amounts) **ONLY** into the green column. The percentages will change automatically. **NOTE:** Select the (% Complete) billing tab if you prefer to track your billings based on total project % complete. Once % complete is entered, billable amount will populate automatically. Select the (lump sum) billing tab if you prefer to track your billings as a lump sum billable amount to date. Once lump sum amount is entered, % complete will populate automatically.
 - 6 Send invoice based on the Dollar value at the PRE-RETENTION value, if applicable.

Subsequent Billings

- 7 Manually input the dollar values from the "cost completed to date" column into the blue "total previous billings" column
- 8 Enter the corresponding dollar values:% complete values into the green column for total work complete to date.
- 9 Submit a conditional release waiver with the billing. Submit signed pay request certification form.
- 10 Email (middlestadt@cfwinc.com), or mail to the CFW Oxnard office at 1901 Victoria Ave, Suite 106 Oxnard, CA 93035. Please allow 4-6 weeks for invoice processing prior to payment.
- 11 Please note that invoice amounts which exceed remaining contract balance will not be processed, and will be returned to Vendor pending additional contract agreement(s). Incorrect contract amounts, cost codes, or other errors & miscalculations can delay/prevent processing of payment.

NOTE: All Consultant/Vendor invoices must be accompanied by this worksheet to ensure proper payment. Invoices without this worksheet may be rejected and may delay payment until the next billing cycle or until the spreadsheet becomes accurate. Invoices not received by the 25th may be delayed until the next billing cycle. Contact the Program Manager with any questions regarding billing values, or any other information required, prior to submitting a billing.

Cavignac & Associates

INSURANCE BROKERS

License No. OA99520

450 B Street, Suite 1800
San Diego, CA 92101-8005

Phone 619-234-6848
Fax 619-234-8601
Web Site www.cavignac.com

Oxnard School District
ATTN: Lisa Franz
1051 South 'A' Street
Oxnard, CA, 93030

Oct 29, 2013

Re: NV5, Inc.; BTC Labs - Vertical V, Inc.

To Whom It May Concern:

Enclosed is a certificate of insurance, as requested. If you have questions or require changes, please contact our office via email (certificates@cavignac.com) or fax (619-234-1239). Please include a copy of the certificate with your request or reference ID number 243841.

Sincerely,

Cavignac & Associates Certificate Department
certificates@cavignac.com
619-234-1239 (fax)

cc: Danielle Wooten (danielle.wooten@nv5.com)

Certificate of Insurance for NV5, Inc.; BTC Labs - Vertical V, Inc.



CERTIFICATE OF LIABILITY INSURANCE

DATE (MM/DD/YYYY)
10/29/2013

THIS CERTIFICATE IS ISSUED AS A MATTER OF INFORMATION ONLY AND CONFERS NO RIGHTS UPON THE CERTIFICATE HOLDER. THIS CERTIFICATE DOES NOT AFFIRMATIVELY OR NEGATIVELY AMEND, EXTEND OR ALTER THE COVERAGE AFFORDED BY THE POLICIES BELOW. THIS CERTIFICATE OF INSURANCE DOES NOT CONSTITUTE A CONTRACT BETWEEN THE ISSUING INSURER(S), AUTHORIZED REPRESENTATIVE OR PRODUCER, AND THE CERTIFICATE HOLDER.

IMPORTANT: If the certificate holder is an ADDITIONAL INSURED, the policy(ies) must be endorsed. If SUBROGATION IS WAIVED, subject to the terms and conditions of the policy, certain policies may require an endorsement. A statement on this certificate does not confer rights to the certificate holder in lieu of such endorsement(s).

PRODUCER Cavignac & Associates 450 B Street, Suite 1800 San Diego, CA 92101-8005 License No. OA99520	CONTACT NAME: Certificate Department	
	PHONE (A/C No. Ext): 619-234-6848	FAX (A/C, No): 619-234-8601
E-MAIL ADDRESS: certificates@cavignac.com		
INSURER(S) AFFORDING COVERAGE		NAIC #
INSURER A: TRAVELERS PROP CAS CO OF AMER		25674
INSURER B: TRAVELERS IND CO OF CT		25682
INSURER C: HUDSON INS CO		25054
INSURER D:		
INSURER E:		
INSURER F:		

COVERAGES	CERTIFICATE NUMBER: 243841	REVISION NUMBER:
------------------	-----------------------------------	-------------------------

THIS IS TO CERTIFY THAT THE POLICIES OF INSURANCE LISTED BELOW HAVE BEEN ISSUED TO THE INSURED NAMED ABOVE FOR THE POLICY PERIOD INDICATED. NOTWITHSTANDING ANY REQUIREMENT, TERM OR CONDITION OF ANY CONTRACT OR OTHER DOCUMENT WITH RESPECT TO WHICH THIS CERTIFICATE MAY BE ISSUED OR MAY PERTAIN, THE INSURANCE AFFORDED BY THE POLICIES DESCRIBED HEREIN IS SUBJECT TO ALL THE TERMS, EXCLUSIONS AND CONDITIONS OF SUCH POLICIES. LIMITS SHOWN MAY HAVE BEEN REDUCED BY PAID CLAIMS.

INSR LTR	TYPE OF INSURANCE	ADDL INSR	SUBR WVD	POLICY NUMBER	POLICY EFF (MM/DD/YYYY)	POLICY EXP (MM/DD/YYYY)	LIMITS
B	GENERAL LIABILITY <input checked="" type="checkbox"/> COMMERCIAL GENERAL LIABILITY <input type="checkbox"/> CLAIMS-MADE <input checked="" type="checkbox"/> OCCUR <input checked="" type="checkbox"/> Cross Liab/Sev of Int GEN'L AGGREGATE LIMIT APPLIES PER: <input type="checkbox"/> POLICY <input checked="" type="checkbox"/> PRO-JECT <input type="checkbox"/> LOC		X	6806B97547A	5/1/2013	5/1/2014	EACH OCCURRENCE \$ 1,000,000 DAMAGE TO RENTED PREMISES (Ea occurrence) \$ 1,000,000 MED EXP (Any one person) \$ 10,000 PERSONAL & ADV INJURY \$ 1,000,000 GENERAL AGGREGATE \$ 2,000,000 PRODUCTS - COMP/OP AGG \$ 2,000,000 Deductible \$ 0
A	AUTOMOBILE LIABILITY <input checked="" type="checkbox"/> ANY AUTO <input type="checkbox"/> ALL OWNED AUTOS <input type="checkbox"/> SCHEDULED AUTOS <input type="checkbox"/> HIRED AUTOS <input type="checkbox"/> NON-OWNED AUTOS		X	BA6B774609	7/1/2013	5/1/2014	COMBINED SINGLE LIMIT (Ea accident) \$ 1,000,000 BODILY INJURY (Per person) \$ BODILY INJURY (Per accident) \$ PROPERTY DAMAGE (Per accident) \$ \$
A	<input checked="" type="checkbox"/> UMBRELLA LIAB <input checked="" type="checkbox"/> OCCUR <input type="checkbox"/> EXCESS LIAB <input type="checkbox"/> CLAIMS-MADE DED <input checked="" type="checkbox"/> RETENTION \$ \$0			CUP4076T902	7/1/2013	5/1/2014	EACH OCCURRENCE \$ 5,000,000 AGGREGATE \$ 5,000,000 \$
A	WORKERS COMPENSATION AND EMPLOYERS' LIABILITY ANY PROPRIETOR/PARTNER/EXECUTIVE OFFICER/MEMBER EXCLUDED? <input type="checkbox"/> Y/N (Mandatory in NH) If yes, describe under DESCRIPTION OF OPERATIONS below		N/A	UB3893T34A	5/1/2013	5/1/2014	<input checked="" type="checkbox"/> WC STATUTORY LIMITS <input type="checkbox"/> OTHER E.L. EACH ACCIDENT \$ 1,000,000 E.L. DISEASE - EA EMPLOYEE \$ 1,000,000 E.L. DISEASE - POLICY LIMIT \$ 1,000,000
C	Professional Liability			AEE7246003	5/1/2013	5/1/2014	Ea. Claim \$5,000,000 Aggreg \$10,000,000

DESCRIPTION OF OPERATIONS / LOCATIONS / VEHICLES (Attach ACORD 101, Additional Remarks Schedule, if more space is required)

Re: Agreement for Consultant Services #13-154. Additional Insured coverage applies to General and Automobile Liability for Oxnard School District, and its respective elected and appointed officers, officials, employees and volunteers per policy form. Primary coverage applies to General and Automobile Liability per policy form. Prof. Liab. - Claims made, defense costs included within limit, Pollution Liability included per policy form #ADI0510002. Cavignac & Associates will provide 30 days notice of cancellation to the Certificate Holder in the event of policy cancellation.

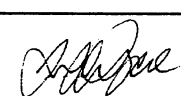
CERTIFICATE HOLDER Oxnard School District 1051 South 'A' Street Oxnard, CA 93030 United States	CANCELLATION SHOULD ANY OF THE ABOVE DESCRIBED POLICIES BE CANCELLED BEFORE THE EXPIRATION DATE THEREOF, NOTICE WILL BE DELIVERED IN ACCORDANCE WITH THE POLICY PROVISIONS. AUTHORIZED REPRESENTATIVE Jeffrey W. Cavignac 
---	--

© 1988-2010 ACORD CORPORATION. All rights reserved.

THIS ENDORSEMENT CHANGES THE POLICY. PLEASE READ IT CAREFULLY.

BUSINESS AUTO EXTENSION ENDORSEMENT

This endorsement modifies insurance provided under the following:

BUSINESS AUTO COVERAGE FORM

With respect to coverage provided by this endorsement, the provisions of the Coverage Form apply unless modified by the endorsement.

GENERAL DESCRIPTION OF COVERAGE – This endorsement broadens coverage. However, coverage for any injury, damage or medical expenses described in any of the provisions of this endorsement may be excluded or limited by another endorsement to the Coverage Part, and these coverage broadening provisions do not apply to the extent that coverage is excluded or limited by such an endorsement. The following listing is a general coverage description only. Limitations and exclusions may apply to these coverages. Read all the provisions of this endorsement and the rest of your policy carefully to determine rights, duties, and what is and is not covered.

- | | |
|---|---|
| A. BROAD FORM NAMED INSURED | H. HIRED AUTO PHYSICAL DAMAGE – LOSS OF USE – INCREASED LIMIT |
| B. BLANKET ADDITIONAL INSURED | I. PHYSICAL DAMAGE – TRANSPORTATION EXPENSES – INCREASED LIMIT |
| C. EMPLOYEE HIRED AUTO | J. PERSONAL EFFECTS |
| D. EMPLOYEES AS INSURED | K. AIRBAGS |
| E. SUPPLEMENTARY PAYMENTS – INCREASED LIMITS | L. NOTICE AND KNOWLEDGE OF ACCIDENT OR LOSS |
| F. HIRED AUTO – LIMITED WORLDWIDE COVERAGE – INDEMNITY BASIS | M. BLANKET WAIVER OF SUBROGATION |
| G. WAIVER OF DEDUCTIBLE – GLASS | N. UNINTENTIONAL ERRORS OR OMISSIONS |

PROVISIONS

A. BROAD FORM NAMED INSURED

The following is added to Paragraph A.1., **Who Is An Insured**, of **SECTION II – LIABILITY COVERAGE**:

Any organization you newly acquire or form during the policy period over which you maintain 50% or more ownership interest and that is not separately insured for Business Auto Coverage. Coverage under this provision is afforded only until the 180th day after you acquire or form the organization or the end of the policy period, whichever is earlier.

B. BLANKET ADDITIONAL INSURED

The following is added to Paragraph c. in A.1., **Who Is An Insured**, of **SECTION II – LIABILITY COVERAGE**:

Any person or organization who is required under a written contract or agreement between you and that person or organization, that is signed and

executed by you before the "bodily injury" or "property damage" occurs and that is in effect during the policy period, to be named as an additional insured is an "insured" for Liability Coverage, but only for damages to which this insurance applies and only to the extent that person or organization qualifies as an "insured" under the **Who Is An Insured** provision contained in Section II.

C. EMPLOYEE HIRED AUTO

1. The following is added to Paragraph A.1., **Who Is An Insured**, of **SECTION II – LIABILITY COVERAGE**:

An "employee" of yours is an "insured" while operating an "auto" hired or rented under a contract or agreement in that "employee's" name, with your permission, while performing duties related to the conduct of your business.

THIS ENDORSEMENT CHANGES THE POLICY. PLEASE READ IT CAREFULLY.

**BLANKET ADDITIONAL INSURED
(ARCHITECTS, ENGINEERS AND SURVEYORS)**

This endorsement modifies insurance provided under the following:

COMMERCIAL GENERAL LIABILITY COVERAGE PART

A. The following is added to WHO IS AN INSURED (Section II):

Any person or organization that you agree in a "contract or agreement requiring insurance" to include as an additional insured on this Coverage Part, but only with respect to liability for "bodily injury", "property damage" or "personal injury" caused, in whole or in part, by your acts or omissions or the acts or omissions of those acting on your behalf:

- a. In the performance of your ongoing operations;
- b. In connection with premises owned by or rented to you; or
- c. In connection with "your work" and included within the "products-completed operations hazard".

Such person or organization does not qualify as an additional insured for "bodily injury", "property damage" or "personal injury" for which that person or organization has assumed liability in a contract or agreement.

The insurance provided to the additional insured is limited as follows:

- d. This insurance does not apply on any basis to any person or organization for which coverage as an additional insured specifically is added by another endorsement to this Coverage Part.
- e. This insurance does not apply to the rendering of or failure to render any "professional services".
- f. The limits of insurance afforded to the additional insured shall be the limits which you agreed in that "contract or agreement requiring insurance" to provide for that additional insured, or the limits shown in the Declarations for this Coverage Part, whichever are less. This endorsement does not increase the limits of insurance stated in the **LIMITS OF INSURANCE (Section III)** for this Coverage Part.

B. The following is added to Paragraph a. of 4. Other Insurance in COMMERCIAL GENERAL LIABILITY CONDITIONS (Section IV):

However, if you specifically agree in a "contract or agreement requiring insurance" that the insurance provided to an additional insured under this Coverage Part must apply on a primary basis, or a primary and non-contributory basis, this insurance is primary to other insurance that is

available to such additional insured which covers such additional insured as a named insured, and we will not share with the other insurance, provided that:

- (1) The "bodily injury" or "property damage" for which coverage is sought occurs; and
- (2) The "personal injury" for which coverage is sought arises out of an offense committed;

after you have entered into that "contract or agreement requiring insurance". But this insurance still is excess over valid and collectible other insurance, whether primary, excess, contingent or on any other basis, that is available to the insured when the insured is an additional insured under any other insurance.

C. The following is added to Paragraph 8. Transfer Of Rights Of Recovery Against Others To Us in COMMERCIAL GENERAL LIABILITY CONDITIONS (Section IV):

We waive any rights of recovery we may have against any person or organization because of payments we make for "bodily injury", "property damage" or "personal injury" arising out of "your work" performed by you, or on your behalf, under a "contract or agreement requiring insurance" with that person or organization. We waive these rights only where you have agreed to do so as part of the "contract or agreement requiring insurance" with such person or organization entered into by you before, and in effect when, the "bodily injury" or "property damage" occurs, or the "personal injury" offense is committed.

D. The following definition is added to DEFINITIONS (Section V):

"Contract or agreement requiring insurance" means that part of any contract or agreement under which you are required to include a person or organization as an additional insured on this Coverage Part, provided that the "bodily injury" and "property damage" occurs, and the "personal injury" is caused by an offense committed:

- a. After you have entered into that contract or agreement;
- b. While that part of the contract or agreement is in effect; and
- c. Before the end of the policy period.

BOARD AGENDA ITEM

Name of Contributor: Janet Penanhoat

Date of Meeting: 4/3/19

STUDY SESSION _____

CLOSED SESSION _____

SECTION A-1: PRELIMINARY _____

SECTION A-II: REPORTS _____

SECTION B: HEARINGS _____

SECTION C: CONSENT AGENDA _____

Agreement Category:

____ Academic

____ Enrichment

____ Special Education

____ Support Services

____ Personnel

____ Legal

X Facilities

SECTION D: ACTION _____

SECTION F: BOARD POLICIES 1st Reading _____ 2nd Reading _____

Approval of Work Authorization Letter #10 (“WAL #10”) for Agreement #13-154 with NV5 West Inc., to provide Environmental Support Services for the McKinna Elementary School Reconstruction Project (Penanhoat/Fateh/CFW)

At the November 13, 2013, regularly scheduled Board Meeting, the Board of Trustees approved Agreement #13-154 with NV5 West, Inc. (formerly known as BTC Labs – Vertical Five) to perform environmental sampling and analysis.

The District, in consultation with CFW recommends issuing Work Authorization Letter #10 to NV5 West, Inc. to perform environmental sampling and report analysis for contaminant soil as per the exhibit and ACAD file provided by CFW. This will include a legal description and an exhibit. This will then be submitted to CFW for review and upon approval CFW will obtain the necessary signatures and record said easements.

The Work Authorization Letter is issued pursuant to and consists of:

Master Agreement: **#13-154**

Work Authorization Letter: **#10**

Consultant: **NV5 West Inc. (formerly known as BTC Labs – Vertical Five)**

Date Issued: **04/03/2019**

FISCAL IMPACT

Six Thousand One Hundred Five Dollars and Zero Cents (\$6,105.00) to be paid out of the Master Construct & Implementation Funds.

RECOMMENDATION

It is the recommendation of the Assistant Superintendent, Business & Fiscal Services, and the Director of Facilities, in consultation with Caldwell Flores Winters, that the Board of Trustees approve WAL #10 for Master Agreement #13-154 with NV5 West Inc.

ADDITIONAL MATERIAL(S)

Attached:

- WAL #10, NV5 West Inc. (1 Page)
- NV5 West Inc. Proposal dated October 2, 2018 (6 Pages)
- Master Agreement #13-154, BTC Labs – Vertical Five (35 Pages)



Caldwell, Flores, Winters, Inc.
1901 S. Victoria Ave., Ste. 106
Oxnard, CA 93035

October 2, 2018
Proposal No. 2018.06.0217

Attention: Sean Mahan

e-mail: smahan@cfwinc.com

Subject: Proposal for Limited Phase 2 Environmental Sampling and Testing of Proposed Import Fill Sources, Proposed McKinna Elementary School 1611 South J Street, Oxnard, CA 93033

Dear Mr. Mahan:

NV5 West, Inc. is pleased to present this proposal to conduct environmental sampling and testing of proposed import sources for the referenced site. NV5 understands that five (5) sites are currently proposed as potential import sources for use as material for placement as engineered fill at McKinna Elementary School. The sites under consideration are as follows:

1. Ventura County Office of Education – Proposed Camarillo Special Education Project located at 5250 Adolfo Road, Camarillo, California;
2. Proposed Montalvo Center located at 1939 & 1981 South Victoria Avenue, Ventura, California;
3. Gold Coast Transit Center located at 1901 Auto Center Drive, Oxnard, California;
4. Grimes Rock located at 3500 Grimes Canyon Road, Fillmore, California; and
5. A currently unspecified location generally identified as 101& Haskell Avenue, Los Angeles, California.

SCOPE OF SERVICES

Limited Phase 2 Environmental Sampling

Per CFW's request, NV5 will perform limited environmental sampling and analysis of representative proposed import soils to evaluate for the potential presence of potential contaminants of concern including pesticides, herbicides, petroleum hydrocarbons, metals, and volatile and semi-volatile organic compounds.

This work does not include application to the California Department of Toxic Substance Control (DTSC) – Brownfields and Environmental Restoration Program for review and oversight (Environmental Oversight Program) or preparation of submittal of a Workplan.

- Collect 1 soil sample (*at each proposed import site*) from representative, distributed locations covering each proposed import source site. Samples will be collected from depth intervals between 0.5 and 1.0 feet below grade. Standard environmental sampling protocols will be followed in compliance with DTSC guidelines.

- Sampling will include a discrete soil for VOCs collected in conformance with EPA Method 5035 using either volatile organic analysis (VOA) kits, Encores, or an equivalent. A composite sample for other analyses methods. Composite samples correspond to three sample depths for one horizontal sampling location. Each composite sample will consist of three discrete samples collected near the top, middle, and bottom of the stockpile at each sampling location.
- Samples will be stored from the time of field sampling through delivery to the analyzing laboratory in ice-chilled insulated coolers. Chain-of-custody records will be maintained for all samples from the field sampler to the analyzing laboratory. Samples will be delivered to the laboratory either by laboratory courier or by field staff.
- If no background information is currently available regarding the environmental history of the site, the complete analysis list required in section 3.02E will be performed. Chemical analysis will be subcontracted to EPA-certified BC Laboratories of Bakersfield, CA. Laboratory analyses will be on standard (8-day) turn-around-time. Analyses will include:

<u>Analysis</u>	<u>Method</u>
SVOC's	EPA 8270
VOC's	EPA 8260
Pesticides Organochlorine+PCBs	EPA 8081/8082
Chlorinated Herbicides	EPA 8151A
Organophosphorus Pesticides	EPA 8141A
Arsenic/Thallium*	EPA 6020
Hexavalent Chromium	EPA 7199

- Findings will be summarized into a limited environmental sampling report including a site plan showing sampling locations, a summary table of laboratory test results, and a discussion of findings.

The report will include a Preliminary Endangerment Assessment. If analysis indicated the presence of contaminants above minimum action levels, additional studies will be required beyond the scope of services provided herein.

QUALIFICATIONS

All work will be performed under the supervision of Scott Moors. Mr. Moors is a California-licensed Professional Geologist (#6100), Certified Engineering Geologist (#1901), and Certified Hydrogeologist (#607). Mr. Moors has over 25 years of directly related environmental experience.

SITE ACCESS

We will need the name and contact phone number of the appropriate individual capable of providing access to each property to assist NV5. This individual should be aware of the purpose of the visit and willing to cooperate with the process of the field visit. Any delay in scheduling the field inspection could result in delay of the report delivery.

PROPERTY DOCUMENTS

We will need, if not already provided, a copy of any documents that are available (i.e. prior environmental reports, engineering report, title commitments, chain of title report, etc.) to assist in the completion of this project as soon as possible.

SCHEDULE

NV5 is prepared to begin this project immediately following receipt of your written authorization to proceed. We will forward the final Phase 1 ESA report to you within four weeks of authorization. Phase 2 sampling reporting will follow within approximately two additional weeks. Some data reporting could be delayed due to regulatory agency file search request response time outside of NV5's control. Construction phase services will depend upon contractor schedules.

FEES

NV5 will perform the services described in the scope of work for the lump sum fee presented below.

Task	Estimated Schedule (Working Days)	Estimated Cost
Task: Limited Phase 2 Sampling and Testing	15	\$ 6,105
TOTAL FEE ESTIMATE	15	\$ 6,105

MISCELLANEOUS

The scope of work outlines activities that NV5 will conduct during this project. Completion of the scope of work within the schedule and for the fees noted above, NV5 assumes the following:

- NV5 will prepare and issue our final report (2 hard copies and 1 PDF) once the readily available information is gathered and reviewed; no draft report will be issued.
- NV5 understands that you or your representatives will provide, as needed during the project, access to the subject properties and to persons knowledgeable of property operations and history.

Any unexpected conditions or concerns that become apparent during the project, such as deviation from the assumptions outlined herein, may require a revision in the project scope, schedule, and fees. NV5 will immediately notify you of any necessary change in project scope and fees, and obtain written confirmation of such changes. If NV5's work is encumbered or stopped by your actions, such as failure to arrange property access, you will be charged additional fees according to our fee schedule. Should additional environmental work be performed, you will be billed on a time and materials basis according to our fee schedule.

NV5 will conduct subject services according to our standard terms and conditions. This proposal is valid for 60 days.

NV5 appreciates the opportunity to submit this proposal to you. For your convenience, the proposal is presented in a form that can be accepted as an agreement. To accept this proposal, please sign below and return a copy to me.

GENERAL TERMS AND CONDITIONS

1. The Agreement. This Agreement between the parties, which shall describe and govern Client's engagement of "Consultant" to provide "Services" in connection with the "Project" identified in the "Proposal", consists of the Proposal, these terms and conditions, Consultant's fee schedule, and any exhibits or attachments referenced in any of these documents. Together these elements constitute the entire agreement between the parties, superseding any and all prior negotiations, correspondence, or agreements, either written or oral, with respect to the subject matter of this engagement. Consultant requests written acceptance of the Agreement through its Proposal Acceptance Form, but the following actions shall also constitute Client's acceptance of the Agreement: (1) issuing an authorizing purchase order for any of the Services; (2) authorizing Consultant's presence on site; or (3) notification, written (including e-mail) or oral, to Consultant to proceed with any of the Services.

2. Standard of Care. The Services shall be performed in a manner consistent with the level of care and skill ordinarily exercised by members of Consultant's profession currently practicing under similar conditions and in the same locality as the Project. Data, interpretations and recommendations by Consultant will be based solely on information discovered by, or made available to, consultant during the course of the engagement. In connection with such information, Client recognizes that subsurface conditions may vary from those observed at locations where borings, surveys, or explorations are made, and that site conditions may change over time. Consultant shall not be responsible for the use or interpretation of such information by non-parties to this Agreement. Consultant shall not be held liable for problems that may occur if Consultant's recommendations are not followed.

3. Site Access and Conditions. Client will provide Consultant access to the Project site for all equipment and personnel necessary for the performance of the Services. As required to effectuate such access, Client will notify all owners, lessees, contractors, subcontractors, and other possessors of the Project site that Consultant must be allowed free access to the site. While Consultant agrees to take reasonable precautions to minimize damage to the site, Client understands that, in the normal course of performing the Services, some damage may occur, and further understands that Consultant is not responsible for the correction of any such damage unless so specified in the Proposal. Client is responsible for the accuracy of locations for all subterranean structures and utilities. Consultant will take reasonable precautions to avoid known subterranean structures and utilities, and Client waives any claim against Consultant, and agrees to defend, indemnify, and hold Consultant harmless from any claim or liability for injury or loss of any party, including costs of defense, arising from damage done to subterranean structures and utilities not identified or accurately located. In addition, Client agrees to compensate Consultant for any time spent or expenses incurred by Consultant in defense of any such claim with compensation to be based upon Consultant's prevailing fee schedule and expense reimbursement policy.

4. Cooperation and Project Understanding. To the extent requested by Consultant, Client will make available to Consultant all information in its possession regarding existing and proposed conditions at the site. Such information shall include, but not be limited to engineering reports, plot plans, topographic surveys, hydrographic data, soil data including borings, field and laboratory tests and written reports. Client shall immediately transmit to Consultant any new information concerning site condition which becomes available, and any change in plans or specifications concerning the Project to the extent such information may affect Consultant's performance of the Services. Client agrees, upon 24 hours oral or written notice, to provide a representative at the job site to supervise and coordinate the Services. Consultant shall not be liable for any inaccurate or incorrect advice, judgment or decision which is based on any inaccurate information furnished by Client and Client shall indemnify Consultant against claims, demands, or liability arising out of, or contributed to, by such inaccurate information.

5. Sample Disposal. Unless other arrangements are made, Consultant will dispose of all soil and rock samples remaining at the time of report completion. Further storage or transfer of samples can be arranged at Client's prior written request, subject to a reasonable charge by Consultant. Client acknowledges that contaminated drill cuttings, sample spoils, wash water, and other materials may be produced as a result of encountering hazardous materials at the site. In such event, Consultant shall properly contain, label, and store such materials on-site, and Client shall be responsible for its proper transportation and disposal. Consultant may be able to arrange for the transportation and disposal of hazardous materials at Client's request.

6. Construction Monitoring. If Consultant is engaged by Client to provide a site representative for the purpose of monitoring specific portions of any construction work, as set forth in the Proposal, then this Section 6 shall apply. If Consultant's engagement does not include such construction monitoring, then this Section shall be null and void. In connection with construction monitoring, Consultant will report observations and professional opinions to Client. Consultant shall report to Client any observed work which, in Consultant's opinion, does not conform to plans and specifications. Consultant shall have no authority to reject or terminate the work of any agent or contractor of Client. No action, statements, or communications of Consultant, or Consultant's site representative, can be construed as modifying any agreement between Client and others. Consultant's presence on the Project site in no way guarantees the completion or quality of the performance of the work of any party retained by Client to provide construction related services. Neither the professional activities of Consultant, nor the presence of Consultant or its employees, representatives, or subcontractors on the Project Site, shall be construed to impose upon Consultant any responsibility for methods of work performance, superintendence, sequencing of construction, or safety conditions at the Project site. Client acknowledges that Client its general contractor or construction manager is solely responsible for job site safety, and warrants and agrees that such responsibility shall be made evident in any Project owner's agreement with the general contractor. Client also agrees to make Consultant an additional insured under any general contractor's general liability insurance policy. Prior to the commencement of the Work, Client shall provide Consultant with a certificate of insurance evidencing the required insurance. Such certificates shall be issued by an insurance carrier(s) acceptable to Consultant and shall be endorsed to include: (1) Consultant as additional insured; and (2) a waiver of subrogation as to Consultant. This insurance shall be primary to any insurance available to Consultant. In the event Consultant expressly assumes any health and safety responsibilities for hazardous materials or other items specified in this Agreement, the acceptance of such responsibility does not and shall not be deemed an acceptance of responsibility for any other health and safety requirements, such as, but not limited to, those relating to excavation, trenching, drilling or backfilling

7. Project Changes. In the event Client, the Project owner, or other party makes any changes in the plans and specifications, Client agrees to hold Consultant harmless from any liability arising out of such changes, and Client assumes full responsibility unless Client has given Consultant prior notice and has received Consultant's written consent for such changes.

8. Ownership of Documents. All reports, boring logs, field data, field notes, laboratory test data, calculations, estimates and other documents prepared by Consultant in connection with this engagement, shall remain the property of Consultant.

9. Termination. This Agreement may be terminated without cause by either party upon thirty (30) days written notice, and at any time by either party if the other party defaults in the performance of any material provision of this Agreement and such default continues for a period of seven (7) days after written notice thereof. In the event of termination, Consultant will be paid for Services performed through the date of termination, plus reasonable termination expenses, including the cost of completing analyses, demobilization, records and reports necessary to document job status at the time of termination.

10. Risk Allocation and Limitation of Liability. To the fullest extent permitted by law, and not withstanding any other provision of this Agreement, the total liability, in the aggregate, of the Consultant, and its officers, directors, partners, employees, agents and sub-consultants, and any of them, to the Client and anyone claiming by, through or under the Client, for any and all claims, losses, costs or damages of any nature whatsoever arising out of, resulting from or in any way related to the Project or the agreement from any cause or causes, including but not limited to the negligence, professional errors or omissions, strict liability, breach of contract or warranty, express or implied, of the Consultant, and its officers, directors, employees, agents or sub-consultants, or any of them, shall not exceed the total compensation received by the Consultant, for Services provided under this Agreement or \$50,000 whichever is more. Client agrees that Consultant shall not be responsible for the means, methods, procedures performance, site safety of the construction contractors or subcontractors, or for their errors or omissions. Client agrees that the work created pursuant to this Agreement is for the sole and exclusive use of Client and is not for the benefit of any third parties. This Agreement and the Services to be performed hereunder shall in no way be construed as a guarantee of deficient-free construction.

11. Discovery of Unanticipated Hazardous Materials. Client warrants that it has made reasonable efforts to inform Consultant of known or suspected hazardous materials on or near the Project site. The parties acknowledge that hazardous materials may exist at a site where there is no reason to believe they are present. Consultant and Client agree that the discovery of such unanticipated hazardous materials constitutes a changed condition which may require either a renegotiation of the scope of Consultant's Services or termination of such Services or this Agreement. Consultant agrees to notify Client as soon as practicable should hazardous materials be

encountered at the site. Client agrees that in the event of the discovery of hazardous materials at the site it will report such discovery to the proper authorities as required by Federal, State, and local regulations. Client agrees to make the required report at the recommendation of Consultant, or, if unable to do so, authorizes Consultant to make such report. Client also agrees to inform the Project site owner in the event that hazardous materials are encountered at the site. Notwithstanding any other provision of this Agreement, Client waives any claim against Consultant, and to the maximum extent permitted by law, agrees to defend, indemnify, and save Consultant harmless from any claim, liability and/or defense costs for injury or loss arising from the presence of hazardous materials on the Project site, including any costs created by delay of the Project and any costs associated with possible reduction of the property's value. Client is responsible for ultimate disposal of any samples secured by Consultant which are found to be contaminated.

12. Subsurface Conditions. Consultant cannot know or guarantee the exact composition of a site's subsurface, even after conducting a comprehensive exploratory program. Client acknowledges that there is a risk that drilling and sampling may result in contamination of certain subsurface areas. Although Consultant will take reasonable precautions to avoid such an occurrence, Client waives any claim against, and agrees to defend, indemnify and save Consultant harmless from any claim or liability for injury or loss which may arise as a result of subsurface contamination caused by drilling, sampling, or monitoring well installation. Client also agrees to adequately compensate Consultant for any time spent and expenses incurred in defense of any such claim.

13. Insurance. Consultant shall not (1) post a bond, (2) insure, or (3) indemnify Client against losses caused from the acts or omissions of other Contractors or Subcontractors that are not under contract to perform work for Consultant. Client shall require other Contractors and Subcontractors to carry adequate insurance coverage and any performance for Client to insure and indemnify Consultant against claims for damages and to insure compliance or work performance and materials with Project requirements. Client also agrees to make Consultant an additional insured under any general contractor's general liability insurance policy.

14. Resolution of Disputes. The Client shall make no claim for professional negligence, either directly or by way of a cross complaint against the Consultant, unless the Client has first provided the Consultant with a written certification executed by an independent consultant currently practicing in the same discipline as the Consultant and licensed in the State where the Project is located. This certification shall: (a) contain the name and license number of the certifier; (b) specify the acts or omissions that the certifier contends are not in conformance with the standard of care for a consultant performing professional services under similar circumstances; and (c) state in detail the basis for the certifier's opinion that such acts or omissions do not conform to the standard of care. All claims, disputes, controversies or matters in question arising out of, or relating to, this Agreement or any breach thereof, including but not limited to disputes arising out of alleged design defects, breaches of contract, errors, omissions, or acts of professional negligence, (collectively "Disputes") shall be submitted to mediation before and as a condition precedent to pursuing any other remedy. Upon written request by either party to this Agreement for mediation of any dispute, Client and Consultant shall select a neutral mediator by mutual agreement. Such selection shall be made within ten (10) calendar days of the date of receipt by the other party of the written request for mediation. In the event of failure to reach such agreement or in any instance when the selected mediator is unable or unwilling to serve and a replacement mediator cannot be agreed upon by Client and Consultant within ten (10) calendar days, a mediator shall be chosen as specified in the Mediation Rules of the American Arbitration Association then in effect, or any other appropriate rules upon which the parties may agree. Any cause of action brought against Consultant shall be brought within one year of the work or Services performed under this Agreement.

15. Assigns. Client may not assign this Agreement or any right or obligation hereunder without the prior written consent of Consultant, which shall not be unreasonably withheld or delayed; provided, however, that no consent shall be necessary in the event of an assignment to a successor entity resulting from a merger, acquisition or consolidation by either party or an assignment to an Affiliate of either party if such successor or Affiliate assumes all obligations under this Agreement.

16. Non-Solicitation & Hiring of Employees. To promote an optimum working relationship, the Client agrees in good faith not to directly or indirectly employ or otherwise engage any employee of Consultant or any person employed by Consultant within the prior twelve month period without the prior written consent of Consultant. This restriction shall apply during the term of and for a period of one (1) year after the termination of this Agreement. The Client further agrees that loss of any such employee would involve considerable financial loss of an amount that could not be readily established by Consultant. Therefore, in the event that Client should breach this provision and without limiting any other remedy that may be available to Consultant, the Client shall pay to Consultant a sum equal to the employee's current annual salary plus twelve (12) additional months of the employee's current annual salary for training of a new employee as liquidated damages.

17. Governing Law and Survival. The validity of this Agreement, these terms, their interpretation and performance shall be governed by the laws of the State in which the Project is located. If any of the provisions contained in this Agreement are held illegal, invalid, or unenforceable, the enforceability of the remaining provisions will not be impaired. Limitations of liability, indemnification, and non-solicitation & hiring of employees shall survive the termination of this Agreement for any reason. Failure of a party hereto at any time or times to require performance of any provision hereof shall in no manner affect its right at a later time to enforce the same. No waiver by a party of any condition or of any breach of any term contained in this Agreement shall be effective unless in writing and signed by the waiving party, and no waiver in any one or more instances shall be deemed to be a continuing waiver of any such condition or breach in other instance or a waiver of any other condition or breach of any other term.

18. Billing and Payment. Client shall pay Consultant the lump sum amount indicated in the Proposal, or, if no lump sum amount is indicated, in accordance with the schedule of fees or charges as shown in the Proposal or fee schedule. Backup data on billing will not be available unless prior arrangements have been made. Prior to initiation of the Services, Client is required to remit any retainer specified in the Proposal. Thereafter, Consultant will submit to Client invoices for the balance due, which shall be due and payable immediately upon submission. If Client objects to all or any portion of any invoice, Client will so notify Consultant in writing within ten (10) calendar days of the invoice date, identify the cause of disagreement, and immediately pay that portion of the invoice not in dispute. In the absence of written notification described above, the balance as stated on the invoice shall be deemed accepted. Client shall pay an additional charge of one and one-half (1.5) percent per month (or the maximum percentage allowed by law, whichever is lower) on any delinquent amount. Payment thereafter will first be applied to accrued interest and then to the principal unpaid amount. Consultant shall be entitled to recover for all costs and expenses incurred (including any attorney's fees) in connection with collection of any delinquent amount. Fee schedules are periodically revised. Unless otherwise agreed, new rates apply to ongoing work as such rates are issued. Should Consultant be called upon to testify for or on behalf of the Client on matters arising out of or related to the Work, Client shall compensate Consultant for its time at a rate of two times (2x) the Consultant's standard billing rates.

19. Waiver of Jury Trial. Each party waives its right to a jury trial in any court action arising between the parties, whether under this Agreement or otherwise related to the work being performed under this Agreement.

20. Liability for Others. Consultant shall not be responsible for the acts or omissions of the Client, architect, architect's other consultants, contractor, subcontractor, other third parties or their respective agents, employees, assigns, successors, or other persons performing any of the work. Consultant shall promptly notify Client if Consultant becomes aware of any inconsistencies in the Services or information provided by other parties.

21. Delays. Consultant shall not be liable to Client for delays. Client shall indemnify, defend, and hold harmless Consultant from any actions or claims arising from delays.

22. Waiver. No waiver by a party of any condition or of any breach of any term contained in this Agreement shall be effective unless in writing and signed by the waiving party, and no waiver in any one or more instances shall be deemed to be a continuing waiver of any such condition or breach in other instance or a waiver of any other condition or breach of any other term.

23. Enforceability. This Agreement shall be interpreted by the parties in a manner that ensures this Agreement's compliance with applicable local, state, federal, or foreign laws. The parties affirm that this Agreement is a collaborative effort between Client and Consultant, with no single party considered the drafter of this Agreement or having the drafting of this document construed against them.

24. Severability. Should a court find one of the provisions of this Agreement unenforceable, the remaining provisions of this Agreement shall remain in full force and effect.

25. Entire Agreement. To the extent allowed by law, any agreement that is part of the scope of Consultant's Services and incorporated by reference into this Agreement shall be subordinated to the terms and conditions of this Agreement where they conflict. This Agreement shall be interpreted as though prepared by all parties and shall not be construed unfavorably against either party.

**OXNARD SCHOOL DISTRICT
AGREEMENT FOR CONSULTANT SERVICES
(MASTER AGREEMENT – MATERIALS TESTING, & SPECIAL INSPECTIONS)**

This Agreement for Consultant Services (“Agreement”) is entered into as of this 13th day of November, 2013 by and between the **Oxnard School District** (“District”), with offices located at 1051 South A Street, Oxnard, CA 93030, and **BTC Labs – Vertical Five** (“Consultant”) with a business address at 1868 Palma Avenue, Suite D, Ventura, CA 93003. District and Consultant are sometimes hereinafter individually referred to as “Party” and hereinafter collectively referred to as the “Parties.”

RECITALS

A. District is authorized by *California Government Code* Section 53060, and Board Policy 4368, to contract with independent contractors for the furnishing of services concerning financial, economic, accounting, engineering, legal, administrative and other matters. District has sought, by issuance of a Request for Qualifications, the performance of certain services, with the precise scope of work to be specified at the time of assignment of work.

B. Following submission of a Statement of Qualifications for the performance of services, Consultant was prequalified by District to perform services on behalf of District that may be assigned, or not assigned, at the District’s sole discretion.

C. The Parties desire to formalize the prequalification of Consultant for performance of services and desire that the terms of that performance be as particularly defined and described herein.

OPERATIVE PROVISIONS

NOW, THEREFORE, in consideration of the mutual promises and covenants made by the Parties and contained herein and other consideration, the value and adequacy of which are hereby acknowledged, the Parties agree as follows:

1. **Incorporation of Recitals and Exhibits.** The Recitals set forth above and all exhibits attached to this Agreement, as hereafter amended, are incorporated by this reference as if fully set forth herein.
2. **Master Agreement.** This Agreement sets forth the basic terms and conditions between District and Consultant. It may be supplemented from time to time with an individual Work Authorization Letter (“WAL”) which shall be considered an amendment to this Agreement, and which shall be subject to all the terms and conditions of this Agreement, and any further terms and conditions as set forth in the WAL.
3. **Scope of Services.** The scope of Services to be assigned to Consultant pursuant to a WAL is further defined in **Exhibit F – Scope of Services**, wherein the general responsibilities of Consultant are described pursuant to the discipline(s) for which the Consultant has been deemed prequalified by District as described in this Agreement.
4. **Agreement, Scope of Work, and Assignment of Projects.** District may, from time to time, and at the sole discretion of District, assign to Consultant specific services to be performed by Consultant (the “Services”) pursuant to a WAL. The WAL assignment procedure and associated forms are set forth in **Exhibit A**, which is attached hereto. This Agreement, together with the WAL, sets forth the terms and conditions pursuant to which Consultant will perform such Services on behalf of District. The WAL

RECEIVED NOV 01 2013 *CFW*

shall particularize and describe, among other things, such project(s) for which Consultant is to perform Services, such Services to be performed by Consultant at such project(s), the timeline for the performance of such Services, and the compensation to be paid to Consultant for the performance of such Services.

Term of Agreement. Subject to earlier termination as provided below, this Agreement shall remain in effect from November 13, 2013 through November 12, 2018 (the "Term"). This Agreement may be extended only by amendment, signed by the Parties, prior to the expiration of the Term. Such agreement for extension shall be based upon the showing of good and sufficient cause by Consultant that such extension(s) shall be granted. District shall not be obligated to compensate Consultant for any additional costs if such an extension has been granted to this Agreement. Any provision for additional compensation shall be accommodated via the WAL process as indicated in **Exhibit A**.

5. **Time for Performance.** The scope of the Services set forth in the WAL shall be completed during the Term pursuant to the schedule specified in the WAL. If Services indicated in the WAL cannot be completed within the schedule set forth in the WAL, or if the schedule exceeds the Term of this Agreement, it is the responsibility of Consultant to notify District at least ninety (90) days prior to the expiration of either, with a request for a time extension clearly identifying the cause(s) for the failure to complete the Services within the schedule and/or the Term. Should Consultant fail to provide such notice, and/or the Services not be completed pursuant to that schedule or within the Term, Consultant shall be deemed to be in Default as provided below. District, in its sole discretion, may choose not to enforce the Default provisions of this Agreement and may instead allow Consultant to continue performing the Services.
6. **Additional Services.** Additional Services are services in addition to the Services set forth in the WAL that are provided by Consultant pursuant to a written request by District. Additional Services will require a written request or pre-authorization in writing by District following specific approval of such services by the District Board of Trustees. It is understood and agreed that Consultant shall not perform any Additional Services unless and until Consultant receives specific written approval for such Additional Services from the District Board of Trustees. Any modification of the compensation to be paid to Consultant as a result of Additional Services must be specifically approved in writing by the District Board of Trustees. In the event that the District Board of Trustees approves in writing a modification of the compensation, then Consultant shall be paid for such Additional Services pursuant to Section 8, below. However, it is understood and agreed that if the cause of the Additional Services is the sole or partial responsibility of Consultant, its agents, or any subconsultants or other parties under the charge of Consultant, no additional compensation shall be paid to Consultant. If such conditions exist so as to justify Additional Services as indicated above, which require additional compensation or time in order to be performed, it is the sole responsibility of Consultant to submit a request for Additional Services within ten (10) days of Consultant's discovery of such conditions which require Additional Services. It is understood and agreed that if Consultant performs any services that it claims are Additional Services without receiving prior written approval from the District Board of Trustees, Consultant shall not be paid for such claimed Additional Services.
7. **Compensation and Method of Payment.** This Agreement does not guarantee that District will issue a WAL to Consultant nor does this Agreement guarantee any compensation to Consultant. This Agreement does not create any obligation on the part of District to compensate Consultant absent a WAL indicating compensation due to Consultant once Services are performed. Specific compensation and payment amounts, including approved reimbursable expenses, shall be set forth in the WAL. However, it is understood and agreed that the compensation to be paid to Consultant shall not be in excess of or exceed the rates set forth in **Exhibit B** "Compensation".

a. Each month Consultant shall furnish to District an original invoice for all work performed and expenses incurred during the preceding month for Services performed pursuant to a WAL. The invoice shall clearly indicate the assigned project, the approved WAL, and shall detail charges by the following categories: labor (by sub-category), travel, materials, equipment, supplies, and sub-consultant contracts. Sub-consultant charges, if any, shall be detailed by the following categories: labor, travel, materials, equipment and supplies. District shall independently review each invoice submitted by Consultant to determine whether the work performed and expenses incurred are in compliance with the provisions of this Agreement and the WAL. In the event that no charges or expenses are disputed, the invoice shall be approved and paid according to the terms set forth in subsection b. In the event any charges or expenses are disputed by District, the original invoice shall be returned by District to Consultant for correction and resubmission.

b. Except as to any charges for work performed or expenses incurred by Consultant which are disputed by District, District will use its best efforts to cause Consultant to be paid within forty-five (45) days of receipt of Consultant's correct and undisputed invoice.

c. Payment to Consultant for work performed pursuant to this Agreement and a WAL shall not be deemed to waive any defects in work performed by Consultant.

8. Responsibilities of Consultant:

a. Consultant shall perform all Services as indicated in this Agreement and the WAL to the satisfaction of District.

b. The specific Services of Consultant to be performed shall be indicated in the WAL.

c. Consultant hereby represents and warrants that (a) it is an experienced consultant in the discipline(s) identified in **Exhibit F**, having the skill and the legal and professional ability and the flexibility necessary to perform all of the Services required under this Agreement; (b) it has the capabilities and resources necessary to perform its obligations hereunder; (c) it is familiar with all current laws, rules, regulations and other restrictions which are and may become applicable to the scope of Services under this Agreement, including but not limited to all local ordinances, building codes, and requirements of all Authorities Having Jurisdiction (AHJ) including but not limited to the Division of State Architect (DSA), the Office of Public School Construction (OPSC), the State Facilities Planning Division (SFPD), California Department of Education (CDE), the California Department of General Services (DGS), the Department of Toxic Substances Control (DTSC), the California Environmental Quality Act (CEQA), Title 24 of the California Code of Regulations, the California Education Code, State and Local Fire Authorities, air quality districts, water quality and control boards, and any/all other AHJ; (d) that it will assume full responsibility for all Services performed and all work prepared and furnished to District by its employees, agents, and subconsultants; (e) that it has sufficient financial strength and resources to undertake and complete the Services provided for under this Agreement within the schedule set forth in the WAL; and (f) that it certifies and covenants that all reports, certifications, studies, analyses, and other documents prepared by Consultant shall be prepared in accordance with all applicable laws, rules, regulations, and other requirements in effect at the time of their preparation, or required at their time of submittal to District and or agencies.

d. Consultant shall follow accepted industry standards and practices and comply with all federal, state, and local laws and ordinances applicable to the Services required by this Agreement and the WAL.

9. Responsibilities of District.

- a. District will prepare and furnish to Consultant upon Consultant's request, such information as is reasonably necessary to the performance of the Services required under this Agreement and the WAL. Consultant understands that all information provided to Consultant remains the property of District and shall only be removed from District's possession/premises and/or be photocopied, reproduced, distributed, or otherwise made available to others if such activities are expressly approved in writing by District and/or the Program Manager. Failure to comply with the above requirements shall be reasonable cause for termination of this Agreement, and may subject Consultant to liability for damages to District.
 - b. If needed by Consultant, District shall provide information as to the requirements and educational program for each project assigned by a WAL, including approved budget and schedule limitations.
 - c. District shall facilitate and coordinate cooperation amongst and between District consultants, including but not limited to architects, construction managers, surveyors, geotechnical engineers, inspectors, testing laboratories, hazardous materials specialists, CEQA/DTSC compliance specialists, technology experts, and any other professional consultants District deems necessary to execute the Facilities Implementation Program. Such coordination shall include the distribution of documentation prepared by individual consultants which may be of service to Consultant in the course of completing the Services.
 - d. District shall facilitate and coordinate cooperation amongst and between District staff and Consultant, as required to complete the Services.
 - e. District shall provide for the timely approval and execution of the WALs, Additional Services requests, invoices, and any other documentation that requires District action in order for Consultant to complete the Services.
10. **Suspension.** District may, for any reason or no reason, in District's sole discretion, suspend all or a portion of this Agreement, the WAL, or the Services by giving ten (10) calendar days written notice of suspension to Consultant. In the event such notice is given, Consultant shall cease immediately all work in progress. If District suspends the Services for a period of ninety (90) consecutive calendar days or more and, in addition, if such suspension is not caused by Consultant or the acts or omissions of Consultant, then if the Services are resumed, Consultant's compensation shall be subject to adjustment to provide for actual direct costs and expenses incurred by Consultant as a direct result of the suspension and resumption by District of the Services.
11. **Termination.** This Agreement, the WAL, or the Services may be terminated at any time by mutual agreement of the Parties or by either Party as follows:
- a. District may terminate all or a portion of this Agreement, the WAL, or the Services without cause at any time by giving ten (10) calendar days written notice of termination to Consultant. In the event such notice is given, Consultant shall cease immediately all work in progress; or
 - b. District may terminate all or a portion of this Agreement, the WAL, or the Services for cause in the event of a Default by giving written notice pursuant to Section 15, below; or
 - c. Consultant may terminate this Agreement or the WAL at any time upon thirty (30) calendar days written notice if District fails to make any undisputed payment to Consultant when due and such failure remains uncured for forty-five (45) calendar days after written notice to District.

12. **Similar or Identical Services.** In the event that this Agreement, the WAL, or any of the Services are terminated in whole or in part as provided herein, District may procure, upon such terms and in such manner as District may determine appropriate, services similar or identical to those terminated to complete any unfinished Services or new services as needed by District.
13. **Inspection and Final Acceptance.** District acceptance of any of work or Services, whether specifically in writing or by virtue of payment, shall not constitute a waiver of any of the provisions of this Agreement or the WAL including, but not limited to, indemnification and insurance provisions.
14. **Default.** Failure of Consultant to perform any Services or comply with any provisions of this Agreement or the WAL constitutes a Default. District may terminate all or any portion of this Agreement, the WAL, or the Services for cause in the event of a Default. The termination shall be effective if Consultant fails to cure such Default within thirty (30) calendar days following issuance of written notice thereof by District, or if the cure by its nature takes longer, fails to commence such cure within thirty (30) calendar days from the date of issuance of the notice and diligently prosecutes such cure to the satisfaction of District. If Consultant has not cured the Default, District may hold all invoices and may choose to proceed with payment on said invoices only after the Default is cured to District's satisfaction. In the alternative, District may, in its sole discretion, during the period before Consultant has cured the Default, elect to pay any portion of outstanding invoices that corresponds to Services satisfactorily rendered. Any failure on the part of District to give notice of Consultant's default shall not be deemed to result in a waiver of District's legal rights or any rights arising out of any provision of this Agreement or the WAL.
 - a. In addition to District's termination rights set forth above, District shall have (i) the right to cure Consultant's Default at Consultant's cost, in which case all amounts expended by District in connection with such cure shall accrue interest from the date incurred until repaid to District by Consultant at the rate of ten percent (10%) per annum; and (ii) all other rights and remedies available to District at law and in equity, including, without limitation, an action for damages. District shall have the right to retain unpaid earned balances to offset damages, and/or charge Consultant for all damages above and beyond unpaid balance of WAL.
15. **Ownership of Documents.** All maps, models, designs, drawings, photographs, studies, surveys, reports, data, notes, computer files, files and other documents prepared, developed or discovered by Consultant in the course of providing any Services pursuant to this Agreement or the WAL (collectively and individually, the "Documents") shall become the sole property of District and may be used, reused or otherwise disposed of by District without the permission of Consultant. Upon completion, expiration or termination of this Agreement or the WAL, Consultant shall turn over to District all such Documents.
16. **Use of Documents by District.** If and to the extent that District utilizes for any purpose not related to this Agreement or the WAL any Documents, Consultant's guarantees and warranties related to Standard of Performance under this Agreement or the WAL shall not extend to such use of the Documents.
17. **Consultant's Books and Records.** Consultant shall maintain any and all documents and records demonstrating or relating to Consultant's performance of Services pursuant to this Agreement or the WAL for a minimum of four years after termination or expiration of this Agreement and the WAL, or longer if required by law. Such records shall include at minimum a detailed record of daily performance, staff time records, subconsultants time records, documentation of all costs incurred by Consultant that were billed to District, and detailed records of all Consultant fees, overhead, and profit on earned amounts.

- a. Consultant shall maintain any and all ledgers, books of account, invoices, vouchers, canceled checks, or other documents or records evidencing or relating to work, services, expenditures and disbursements charged to District pursuant to this Agreement or the WAL for a minimum of four years, or longer if required by law, all in accordance with generally accepted accounting principles and with sufficient detail so as to permit an accurate evaluation of the Services provided by Consultant pursuant to this Agreement or the WAL.
- b. Any and all such records or documents shall be made available for inspection, audit and copying, at any time during regular business hours, upon request by District or its designated representative. Copies of such documents or records shall be provided directly to District for inspection, audit and copying when it is practical to do so; otherwise, unless an alternative is mutually agreed upon, such documents and records shall be made available at Consultant's address indicated for receipt of notices in this Agreement.
- c. District has the right to acquire custody of such records by written request if Consultant decides to dissolve or terminate its business. Consultant shall deliver or cause to be delivered all such records and documents to District within sixty (60) days of receipt of the request.
18. **Independent Contractor.** Consultant is retained as an independent contractor and is not employed by District. No employee or agent of Consultant shall become, or be considered to be, an employee of District for any purpose. It is agreed that District is interested only in the results obtained from the Services under this Agreement and the WAL and that Consultant shall perform as an independent contractor with sole control of the manner and means of performing the Services required under this Agreement and the WAL. Consultant shall complete this Agreement and the WAL according to its own methods of work which shall be in the exclusive charge and control of Consultant and which shall not be subject to control or supervision by District except as to results of the Services. Consultant shall provide all of its own supplies, equipment, facilities, materials, manpower, and any/all other resources that may become necessary in the course of completing the Services. It is expressly understood and agreed that Consultant and its employees shall in no event be entitled to any benefits to which District employees are entitled, including, but not limited to, overtime, retirement benefits, insurance, vacation, worker's compensation benefits, sick or injury leave or other benefits. Consultant will be responsible for payment of all of Consultant's employees' wages, payroll taxes, employee benefits and any amounts due for federal and state income taxes and Social Security taxes since these taxes will not be withheld from payments under this Agreement or the WAL.
- a. The personnel performing the Services under this Agreement and the WAL on behalf of Consultant shall at all times be under Consultant's exclusive direction and control. Consultant, its agents or employees shall not at any time or in any manner represent that Consultant or any of Consultant's officers, employees, or agents are in any manner officials, officers, employees or agents of District.
- b. Consultant shall have no authority to bind District in any manner, or to incur any obligation, debt or liability of any kind on behalf of or against District, whether by contract or otherwise, unless such authority is expressly conferred in writing by District, or under this Agreement.
19. **Standard of Performance.** Consultant represents and warrants that it has the skill, qualifications, experience and facilities necessary to properly perform the Services required under this Agreement and the WAL in a thorough, competent and professional manner. Consultant represents and warrants that its employees and subcontractors have all legally required licenses, permits, qualifications and approvals necessary to perform the Services and that all such licenses and approvals shall be maintained throughout the term of this Agreement and the WAL. Consultant shall at all times faithfully, competently and to the best of its ability, experience and talent, perform all Services

described herein and the WAL. In meeting its obligations under this Agreement and the WAL, Consultant shall employ, at a minimum, the standard of care utilized by persons engaged in providing services similar to those required of Consultant under this Agreement and the WAL for California school districts in or around the same geographic area of District (the “Standard of Performance”).

20. **Confidential Information.** All information gained during performance of the Services and all Documents or other work product produced by Consultant in performance of this Agreement and the WAL shall be considered confidential (“confidential information”). Consultant shall not release or disclose any such confidential information, Documents or work product to persons or entities other than District without prior written authorization from the Superintendent of District and/or Program Manager, except as may be required by law. Confidential information does not include information that: (i) Consultant had in its possession prior to considering entering into this Agreement; (ii) becomes public knowledge through no fault of Consultant; (iii) Consultant lawfully acquires from a third party not under an obligation of confidentiality to the disclosing party; or (iv) is independently developed by Consultant without benefit of the information provided by District. In connection with confidential information:

a. Consultant shall promptly notify District if it is served with any summons, complaint, subpoena or other discovery request, court order or other request from any party regarding this Agreement or the WAL or the Services performed hereunder or the WAL.

b. District retains the right, but has no obligation, to represent Consultant or be present at any deposition, hearing or similar proceeding. Consultant agrees to cooperate fully with District and to provide District with the opportunity to review any response to discovery requests provided by Consultant; provided that this does not imply or mean the right by District to control, direct, or rewrite said response.

21. **Conflict of Interest; Disclosure of Interest.** Consultant covenants that neither it, nor any officer or principal of its firm, has or shall acquire any interest, directly or indirectly, which would conflict in any manner with the interests of District or which would in any way hinder Consultant’s performance of the Services under this Agreement or the WAL. Consultant further covenants that in the performance of this Agreement and the WAL, no person having any such interest shall be employed by it as an officer, employee, agent or subcontractor without the express written consent of District. Consultant agrees to at all times avoid conflicts of interest or the appearance of any conflicts of interest with the interests of District in the performance of this Agreement and the WAL.

a. Bylaws of the Board 2030(A) E, 2030(B) E and 2030(C) E, as hereinafter amended or renumbered, require that a consultant that qualifies as a “designated employee” must disclose certain financial interests by filing financial interest disclosures. By its initials below, Consultant (i) represents that it has received and reviewed a copy of the Bylaws of the Board 2030(A) E, 2030(B) E and 2030(C) E and that it does does not qualify as a “designated employee”; and (ii) agrees to notify District, in writing, if Consultant believes that it is a “designate employee” and should be filing financial interest disclosures, but has not been previously required to do so by District.

 (Initials)

22. **Compliance with Applicable Laws.** In connection with the Services and its operations, Consultant shall keep itself informed of and comply with all applicable federal, state and local laws, statutes, codes, ordinances, regulations and rules including, but not limited to, minimum wages and/or prohibitions against discrimination, in effect during the Term. Consultant shall obtain any and all licenses, permits and authorizations necessary to perform the Services. Neither District, nor any

elected or appointed boards, officers, officials, employees or agents of District shall be liable, at law or in equity, as a result of any failure of Consultant to comply with this section.

a. Without limiting the generality of the foregoing, Consultant, unless exempted, shall comply with the requirements of Education Code Section 45125.1 with respect to fingerprinting of employees who may have contact with District's pupils. Consultant must complete District's certification form, attached herein as Exhibit E, prior to any of Consultant's employees coming into contact with any of District's pupils. Consultant also agrees to comply with all other operational requirements of District, as may be revised from time to time, including but not limited to any obligations relating to vaccination or testing for infectious diseases.

 (Initials)

23. **Unauthorized Aliens.** Consultant hereby promises and agrees to comply with all of the provisions of the Federal Immigration and Nationality Act, 8 U.S.C.A. §§ 1101, et seq., as amended, and in connection therewith, shall not employ "unauthorized aliens" as that term is defined in 8 U.S.C.A. §1324a(h)(3). Should Consultant so employ such individuals for the performance of work and/or Services covered by this Agreement or the WAL, and should any liability or sanctions be imposed against District for such employment, Consultant hereby agrees to and shall reimburse District for the cost of all such liabilities or sanctions imposed, together with any and all costs, including attorneys' fees, incurred by District.
24. **Non-Discrimination.** Consultant shall abide by the applicable provisions of the United States Civil Rights Act of 1964 and other provisions of law prohibiting discrimination and shall not discriminate, in any way, against any person on the basis of race, color, religious creed, national origin, ancestry, sex, sexual orientation, age, physical handicap, medical condition or marital status in connection with or related to the performance of this Agreement or the WAL.
25. **Disabled Veteran Business Enterprise Participation.** Pursuant to Education Code section 17076.11, District has a participation goal for disabled veteran business enterprises (DVBES) of at least three (3) percent, per year, of funds expended each year by District on projects that use funds allocated by the State Allocation Board pursuant to the Leroy F. Greene School Facilities Act. Unless waived in writing by District, Consultant shall provide proof of DVBE compliance, in accordance with any applicable policies of District or the State Allocation Board, within thirty (30) days of its execution of this Agreement
26. **Assignment.** The expertise and experience of Consultant are material considerations for this Agreement and the WAL. District has an interest in the qualifications of and capability of the persons and entities that will fulfill the duties and obligations imposed upon Consultant under this Agreement and the WAL. In recognition of that interest, Consultant shall not assign or transfer this Agreement or any portion of this Agreement or any portion of the WAL or the performance of any of Consultant's duties, Services or obligations under this Agreement or the WAL without the prior written consent of District and approved by District's Board of Trustees. Any attempted assignment shall be ineffective, null and void, and shall constitute a material breach of this Agreement and the WAL entitling District to any and all remedies at law or in equity, including summary termination of this Agreement and the WAL.
27. **Subcontracting.** Notwithstanding the above, Consultant may utilize subcontractors in the performance of its duties pursuant to this Agreement and the WAL, but only with the prior written consent of District. Consultant shall be as fully responsible to District for the acts and omissions of its subcontractors, and of persons either directly or indirectly employed by Consultant's subcontractors, as if the acts and omissions were performed by Consultant directly.

28. **District Administrator.** Lisa Franz shall be in charge of administering this Agreement on behalf of District, (the “Administrator”) provided that any written notice or any consent, waiver or approval of District must be signed by the Superintendent or a designated employee of District to be valid. The Administrator has completed Exhibit D “Conflict of Interest Check” attached hereto.

29. **Continuity of Personnel.** Consultant shall make every reasonable effort to maintain the stability and continuity of Consultant’s staff and subcontractors consistent with the staff proposed as part of the Statement of Qualifications, if any, assigned to perform Services under this Agreement and the WAL.

a. Consultant shall provide District and the Administrator a list of all personnel and subcontractors providing Services and shall maintain said list current and up to date at all times during the Term. The list shall include the following information: (1) all full or part-time staff positions by title, including volunteer positions whose direct services are required to provide the Services; (2) a brief description of the functions of each such position and the hours each position works each week or, for part-time positions, each day or month, as appropriate; (3) the professional degree, if applicable, and experience required for each position; and (4) the name of the person responsible for fulfilling the terms of this Agreement and the WAL.

30. **Indemnification.** To the fullest extent permitted by law, Consultant shall defend and indemnify District and its officials, elected board members, employees and agents (“Indemnified Parties”) from and against all claims that arise out of, pertain to, or relate to the negligence, recklessness, or willful misconduct of the Consultant, its officers, employees, consultants, subcontractors, or agents, pursuant to this Agreement and/or the WAL, but not for any loss, injury, death or damage caused by the active negligence or willful misconduct of any of the Indemnified Parties.

a. Consultant agrees to obtain executed indemnity agreements with provisions identical to the above from each and every subcontractor retained or employed by Consultant in the performance of this Agreement and the WAL. Failure of District to monitor compliance with these requirements imposes no additional obligations on District and will in no way act as a waiver of any rights hereunder. Consultant’s obligation to indemnify and defend District as set forth above is binding on the successors, assigns or heirs of Consultant and shall survive the termination of this Agreement and the WAL.

 (Initials)

31. **Insurance.** Consultant agrees to obtain and maintain in full force and effect during the term of this Agreement the insurance policies set forth in Exhibit C “Insurance” and made a part of this Agreement. All insurance policies shall be subject to approval by District as to form and content. These requirements are subject to amendment or waiver if so approved in writing by the District Superintendent.

32. **Notices.** All notices required or permitted to be given under this Agreement or the WAL shall be in writing and shall be personally delivered, or sent by telecopier or certified mail, postage prepaid and return receipt requested, addressed as follows:

To District: Oxnard School District
1051 South A Street
Oxnard, California, 93030
Attention: Lisa Cline
Assistant Superintendent, Business & Fiscal Services
Re: [Insert Project Name]

With electronic copy to: Caldwell Flores Winters, Inc.
Oxnard School District Program Manager
6425 Christie Ave., Suite 270
Emeryville, California 94608
Attention: Yuri Calderon
T: 510-596-8170
Email: ycalderon@cfwinc.com

To Consultant: BTC Labs – Vertical Five
1868 Palma Drive, Suite A
Ventura, CA 93003
Attention: Scott Moors
T: (805) 656-6074
Email: scott.moors@nv5.com

All notices, demands, or requests to be given under this Agreement or the WAL shall be given in writing and conclusively shall be deemed received when delivered in any of the following ways: (i) on the date delivered if delivered personally; (ii) on the date sent if sent by facsimile transmission and confirmation of transmission is received; (iii) on the date it is accepted or rejected if sent by certified mail; and (iv) the date it is received if sent by regular United States mail.

33. **Excusable Delays.** Neither Party will be liable to the other for unanticipated delays or failures in performance resulting from causes beyond the reasonable control of that Party, including, but not limited to, acts of God, labor disputes or disturbances, material shortages or rationing, riots, acts of war, governmental regulations, communications or utility failures, or casualties; provided that the delayed Party: (i) gives the other Party prompt written notice of such cause; and (ii) uses its reasonable efforts to correct such failure or delay in its performance. The delayed Party's time for performance or cure under this section will be extended for a period equal to the duration of the cause or sixty (60) days, whichever is less.
34. **Entire Agreement; Binding Effect.** This Agreement including Exhibits hereto, contains the entire understanding of the Parties, and supersedes all other written or oral agreements. Consultant shall be entitled to no other benefits other than those specified herein. No changes, amendments or alternations shall be effective unless in writing and signed by both Parties and approved by District's Board of Trustees. Consultant specifically acknowledges that in entering into this Agreement, Consultant relied solely upon the provisions contained in this Agreement and no others. This Agreement shall be binding upon the heirs, executors, administrators, successors and assigns of the Parties.
35. **Amendment.** No changes, amendments to or modifications of this Agreement or the WAL shall be valid, effective or binding unless made in writing and signed by both Parties and approved by the District's Board of Trustees. The Parties agree that this requirement for written modifications cannot be waived and that any attempted waiver shall be void.
36. **Waiver.** Waiver by any Party of any term, condition, or covenant of this Agreement or the WAL shall not constitute a waiver of any other term, condition, or covenant. Waiver by any Party of any breach of the provisions of this Agreement or the WAL shall not constitute a waiver of any other provision or a waiver of any subsequent breach or violation of any provision of this Agreement or the WAL. None of the provisions of this Agreement or the WAL shall be considered waived by either Party unless such waiver is specifically specified in writing. Neither District's review, approval of, nor payment for, any of the Services required under this Agreement or the WAL shall be construed to operate as a waiver of

any rights under this Agreement or the WAL, and Consultant shall remain liable to District in accordance with this Agreement and the WAL for all damages to District caused by Consultant's failure to perform any of the Services to the Standard of Performance. This provision shall survive the termination of this Agreement and the WAL.

- 37. **Governing Law.** This Agreement and the WAL shall be interpreted, construed and governed according to the laws of the State of California. With respect to litigation involving this Agreement, the WAL or the Services, venue in state trial courts shall lie exclusively in the County of Ventura, California.
- 38. **Severability.** If any term, condition or covenant of this Agreement or the WAL is declared or determined by any court of competent jurisdiction to be invalid, void or unenforceable, the remaining provisions of this Agreement and the WAL shall not be affected thereby and the Agreement and WAL shall be read and construed without the invalid, void or unenforceable provision(s).
- 39. **Authority to Execute.** The person or persons executing this Agreement on behalf of Consultant represents and warrants that he/she/they has/have the authority to so execute this Agreement and to bind Consultant to the performance of its obligations hereunder.

IN WITNESS WHEREOF, District and Consultant have executed and delivered this Agreement for consultant services as of the date first written above.

OXNARD SCHOOL DISTRICT:

BTC LABS - VERTICAL FIVE:

Lisa A. Franz
Signature

Scott Moors
Signature

Lisa A. Franz, Director, Purchasing
Typed Name/Title

SCOTT MOORS / President
Typed Name/Title

11-20-13
Date

10-30-2013
Date

Tax Identification Number: 95-6002318

Tax Identification Number: ~~95~~ 27-1979620

- Not Project Related
 Project #13-154

EXHIBIT A
TO AGREEMENT FOR CONSULTANT SERVICES #13-154

WORK AUTHORIZATION PROCEDURES

1. Assignment of Work Authorization

- 1.1. **Request For Proposal (RFP):** At the sole discretion of District, one or more prequalified professional services consultants shall be solicited with a Request For Proposal (“RFP”) for a specific lump sum fixed fee proposal for defined Services to be complete within a defined timeline. For a proposal to be valid it must clearly acknowledge the complete Services requested by District and must include a lump sum fixed fee amount to complete all defined Services, a clearly defined schedule for completion of Services which meets the required timeline defined by District and shows final completion to occur within the Term of this Agreement.
- 1.2. **Evaluation of Proposal:** District’s Program Manager, in consultation with District, shall review each proposal for validity, accuracy, competitiveness, and overall quality of the Services proposed to be performed. In the case where more than one firm is solicited for a scope of defined Services, the Program Manager shall evaluate each proposal thoroughly based on predetermined, objective criteria to ensure a just and fair review of all proposals.
- 1.3. **Selection of Consultant:** Following evaluation of proposals, the consultant whose proposal exhibits the best value for the benefit of District shall be recommended to the Superintendent for approval.
- 1.4. **Work Authorization Letter (WAL):** With the approval of the District Superintendent, the Program Manager shall issue a Work Authorization Letter (“WAL”) to the selected consultant to perform the defined Services as indicated in the RFP, for the lump sum fixed fee amount reflected in the proposal, with all Services to complete within the timeline indicated in the RFP, and the Term set forth in this Agreement. District retains the right to negotiate all terms of the WAL subsequent to the receipt of proposal(s) in order to clarify the scope of Services, and/or make any adjustments to the fee amount and required schedule prior to issuance of the WAL. The WAL shall be considered a binding agreement, and amendment to this Agreement, once executed by Consultant, approved by the District Board of Trustees, and executed by the Superintendent.
- 1.5. **Performance of Services Set Forth in the WAL:** Performance of Services set forth in the WAL shall not commence until final approval by the District Superintendent and Board of Trustees, unless expressly authorized by the District Superintendent and Program Manager. During the course of completing the Services, Consultant shall comply will all provisions of this Agreement and the WAL. All Services set forth in the WAL shall be completed within the schedule set forth in the WAL.
- 1.6. **Close Out of WAL Services:** Upon completion of all Services required by the WAL, Consultant shall submit all required close-out documentation, certifications, records, reports, warranties, and any other information required or requested by District prior to submitting Consultant’s invoice for final payment.
- 1.7. **WAL Form:** See next page for sample Work Authorization Letter.

Not Project Related

Project #13-154

WORK AUTHORIZATION LETTER (WAL)	
GENERAL INFORMATION	
PROJECT #:	DATE:
SITE NAME:	DSA #:
MASTER AGREEMENT #:	OPSC #:
WAL #:	VENDOR ID:
PURSUANT TO MASTER AGREEMENT BETWEEN:	
DISTRICT	CONSULTANT
OXNARD SCHOOL DISTRICT 1051 South A. St. Oxnard , CA 93030 (805) 385-1501	Firm Name: Street: City, State, Zip: Phone:
SCOPE OF SERVICES TO BE PERFORMED UNDER THIS WAL	
(ATTACH ADD'L PAGES AS NECESSARY)	
SCHEDULE OF SERVICES TO BE PERFORMED UNDER THIS WAL	
START DATE:	COMPLETION DATE:
FIXED FEE AMOUNT: _____	
<i>This fee amount is based upon Consultant's proposal dated _____, and subsequent negotiations mutually agreed to by all parties.</i>	
<i>This WAL is inherently a part of the Master Agreement indicated above. It is bound by the general terms and conditions of the Master Agreement. This WAL describes in detail the Consultants specific scope of Services, agreed upon lump sum fixed fee, agreed upon schedule for completion of Services, and other provisions required to clearly indicate the required Services, and terms of this WAL.</i>	
<i>This WAL and associated Master Agreement hereby supersede any and all terms, conditions, and other provisions of the Consultant's proposal, and such terms, conditions, and other provisions are null and void and are not incorporated to any extent as part of this WAL and associated Master Agreement whether or not they are directly superseded by this WAL and/or the associated Master Agreement.</i>	
IN WITNESS THEREOF, THE PARTIES HAVE AGREED TO AND EXECUTED THIS WAL AS SET FORTH BELOW:	
DISTRICT	CONSULTANT
OXNARD SCHOOL DISTRICT	CONSULTANT:
(SIGNATURE) _____	(SIGNATURE) _____
(DATE) _____	(DATE) _____
FOR DISTRICT USE ONLY	
PROJECT MANAGER:	PREPARED BY:
PO #:	PO AMOUNT:
SOURCE OF FUNDS: <input type="checkbox"/> MEASURE "R" <input type="checkbox"/> DEF. MAINT. <input type="checkbox"/> DEV. FEES <input type="checkbox"/> OTHER: _____	
COST ID:	
(PM APPROVAL SIGNATURE) _____	(DATE) _____
SPECIAL INSTRUCTIONS:	

Not Project Related

Project #13-154

EXHIBIT B
TO AGREEMENT FOR CONSULTANT SERVICES #13-154

COMPENSATION & RATE/FEE SCHEDULE

I. The following rates of pay shall apply in the performance of the Services under this Agreement and the WAL:

MATERIALS TESTING & SPECIAL INSPECTIONS FEE SCHEDULE

I. PROFESSIONAL, TECHNICAL, & SUPPORT STAFF

(Hourly rates unless otherwise indicated. Charges are portal-to-portal from/to BTC Labs)

A. Professional Staff		Standard
Principal Engineer/Geologist/Consultant		\$180
Senior Engineer/Geologist/Consultant (PE, CEG)		\$155
Project Engineer/Geologist/Consultant/Manager		\$130
Staff Engineer/Geologist/Consultant		\$105
B. Field Sampling, Inspection & Testing		Standard
Special (Deputy) Inspector	Prevailing Wage	\$78
<i>(Concrete, P/T Concrete, Masonry, Welding, Bolting, Fireproofing)</i>		
Concrete/Asphalt Batch Plant Inspection	\$86	\$78
ACI Concrete Technician	\$86	\$74
Senior Technician* <i>(Soil/Asphalt/Special Testing)</i>	\$88	\$78
Mechanical/Electrical Inspector	\$92	\$90
Roofing/Waterproofing Inspector	\$95	\$85
Nondestructive Exam/Testing (UT/Mag Part./Dye Pen.)	\$92	\$84
Trip Charge (within 25 radius of Lab; if >25 mi. hourly + mileage)		\$30

* Services such as: density by nuclear gauge, Schmidt Hammer readings, pachometer survey, torque tests and pull tests are performed by Senior Technicians

C. DSA / OSPIID Inspection & Testing		Prevailing Wage / Standard
Project Inspector / IOR, DSA Class I		\$110
Project Inspector / IOR, DSA Class II/III		\$95
DSA Masonry / Shotcrete Inspection		\$90
DSA Form 5 (Inspector Qualifications)		\$45 ea.
Special Inspection Verified Report (SIVR/VR)		\$185 (min.) ea.
Laboratory / Geotechnical Verified Report		\$385 (min.) ea.

D. Sample Pickup & Delivery, Mileage		Prevailing Wage	Standard
Sample Pickup (<25mi. radius of Lab) – plus applicable unit price		\$55/hr	
Field Equipment & Supply Delivery (1 hr min)		\$55/hr	
Saturday Pickup (hourly, 4 hr minimum, plus mileage)		\$75/hr	
Mileage – Field Vehicle (\$30/day minimum charge)		\$0.60/mi	
Mileage – Coring Truck		\$0.70/mi	

See Unit Prices for pickup charges of cylinders, prisms, panels, etc.

E. Support Staff & Special Services

	Prevailing Wage	Standard
Laboratory Technician		\$85
File Search, Reissue of Report		\$45 (min.)
Certified Payroll Admin. (0.5 hr min./wk)		\$80
Court Appearance and Depositions (4 hr min)		\$295
Drafting/CADD		\$70
Clerical		\$60

II. MATERIALS AND EQUIPMENT

A. Equipment		Rate
1. Air Meter (Concrete)		\$45/day
2. Calibrated Ram (Pull test)		\$75/day
3. Ceiling Wire Dead-Weight Equip.		\$110/day
4. Concrete Relative Humidity Meter		\$265/day
5. Concrete Slab Moisture Emission Kit		\$55/ea
6. Floor Flatness (plus labor – 4hr min)		\$550/day
7. Generator		\$65/day
8. Ground Penetrating Radar (GPR) – (plus labor – 4 hr min)		\$385/day
9. Magnetic Particle Equipment & Consumables		\$50/day
10. Nuclear Gauge		\$25/day
11. Pachometer (Rebar) Survey Equipment		\$85/day
12. Schmidt Hammer		\$35/day
13. Skidmore Wilhelm, per day		\$75/day
14. Torque Wrench (Large), per day		\$50/day
15. Torque Wrench (Small), per day		\$15/day
16. Ultrasonic Equipment & Consumables		\$60/day
17. Vehicle – Field Truck		\$55/day
B Diamond Coring (min. charge – field time w/travel + 1 hr. mob./demob.)		
1. Machine, truck & 1 operator (accessible flatwork only)	\$190/hr	\$150/hr.
2. Machine, truck, operator and helper	\$275/hr	215/hr.
3. Coring Bit Charge		\$2/inch
4. Coring truck mileage (portal to portal)		\$0.70/mi
5. Traffic Control		Per Quote

Not Project Related

Project #13-154

III. LAB TESTS: AGGREGATE & SOIL

A Soils - Geotechnical

1. Atterberg Limits (LL and PL) - ASTM D4318, CTM 204	\$ 142
2. Consolidation (Incremental Loading) - ASTM D2435	\$ 315
3. Direct Shear, remolded sample - ASTM D3080	\$ 285
4. Direct Shear, undisturbed (ring) sample - ASTM D3080	\$ 235
5. Expansion Index - ASTM D4829	\$ 158
6. Hydrometer analysis (without specific gravity) - ASTM D422	\$ 132
7. Permeability, Constant Head - remolded - ASTM D2434, CT 220	\$ 360
8. pH (soil) - ASTM D4972	\$ 35
9. Resistivity - ASTM G57	\$ 60
10. Resistivity (Minimum), includes pH - CTM 643	\$ 155
11. Soil Cement - Moist.-Dens. or Sample Prep set of 3 - ASTM D558	\$ 240
12. Soil Cement - Wet-Dry Durability - ASTM D559	\$ 1100
13. Soil Cement - Compressive Strength - ASTM D1633	\$ 60
14. Soil Classification - ASTM D2488 - Visual-Manual	\$ 24
15. Soluble Chloride (soils)	\$ 75
16. Soluble Sulfate (soils)	\$ 75
17. Unconfined compression on prepared specimens	\$ 95

B Particle Size Analysis

18. Sand equivalent (ASTM 2419, CTM 217)	\$ 110
19. Sieve #200 wash only (ASTM D1140, CTM 202)	\$ 65
20. Sieve (coarse or fine only, no wash - ASTM C136, CTM 202)	\$ 85
21. Sieve (coarse & fine w/ wash - ASTM C136, CTM 202)	\$ 105
22. Sieve w/ Hydrometer (ASTM D422, CTM 203, no specific grav.)	\$ 165

C Moisture Density Relationship

23. Max. Density-Opt. Moisture (4 in. mold) - ASTM D1557, D698	\$ 175
24. Max. Density-Opt. Moisture (6 in. mold) - ASTM D1557, D698	\$ 195
25. Max. Density-Opt. Moist. w/ Rock Corr. - ASTM D1557, D4718	\$ 295
26. Maximum Density Checkpoint (4 in. mold)	\$ 65
27. Moisture & Dry Density (ring samples)	\$ 20
28. Moisture determination (aggregate samples)	\$ 35
29. Caltrans Relative Compaction (Wet Density) - CTM 216	\$ 225

D Aggregate, Soil & Rock

30. Abrasion Resistance by LA Rattler - ASTM C131, CTM 211	\$ 165
31. Absorption, sand or gravel - ASTM C127, C128	\$ 60
32. California bearing ratio (CBR) with expansion - ASTM D1883	\$ 365
33. California bearing ratio (CBR) at 95% (3 points) - ASTM D1883	\$ 585
34. Cement Treated Base (CTB), compact, cure & test	\$ 225
35. Cement Treated Base - compression (make, cure, test 3 spec)	\$ 565
36. Cement Treated Base - stability	\$ 525
37. Clay lumps and friable particles, per primary size - ASTM C142	\$ 115
38. Cleanness Test - CTM 227	\$ 128
39. Crushed particles, per primary size	\$ 165
40. Durability Index (\$120 per size fraction) - CTM 229	\$ 215
41. Fine Aggregate Angularity - AASHTO T304	\$ 175
42. Flat & Elongated Particles (per bin size) - ASTM D4791	\$ 190
43. Lightweight pieces, per size fraction - ASTM C123	\$ 400
44. Lime content of treated materials (by titration)	
a. Lime content curve determination, for each material	\$ 395
b. Lime content, including untreated control sample	\$ 145
45. Mortar making properties of Sand ASTM C87	\$ 360
46. Mortar Properties - CTM 515	\$ 410
47. Organic Impurities - ASTM C40	\$ 75
48. Petrographic Analysis of Gravel - ASTM C295 (single grading)	\$ 450
49. Petrographic Analysis of WC Sand - ASTM C295 (pre-graded)	\$ 850
50. Potential Reactivity Test ASTM C289 Chemical Method	\$ 495
51. Potential Reactivity ASTM C227 Mortar Bar Method (3 month)	\$ 785
Each additional month	\$ 118
52. Potential Reactivity Test ASTM C1260 Rapid Method	\$ 589
53. Potential Reactivity ASTM C1293 Mortar Bar w/ Pozz (12 month)	\$ 1600
Extend to 24-months add (C1293 requires Sp. Grav. & Unit Weight)	\$ 800
54. Potential Reactivity Test ASTM C1567 Rapid-Cement Combo	\$ 760
55. 'R' Value (HVEEM) (Treated material by quote)	\$ 270
56. Rip Rap, Slope Protection, Quarry Stone Acceptance	Per Quote
57. Specific gravity w/ absorption - coarse (ASTM C127, CTM 206)	\$ 100
58. Specific gravity w/ absorption - fine (ASTM C128, CTM 207)	\$ 125
59. Sulfate Soundness, 5 cycle test per primary size - ASTM C88	\$ 325
60. Uncompacted Void Content of Fine Aggregate - AASHTO T304	\$ 145
61. Unit weight - ASTM C29	\$ 72

IV. LAB TESTS: CEMENT, CONCRETE, & MASONRY

A Cement

1. Alkali content of Portland Cement	Per Quote
2. Grab sample (CCR Title 24) includes 1 year storage	\$ 48
3. Testing individual samples of cement, ASTM C150	Per Quote

B Concrete

1. Cement content of hardened concrete - ASTM 1085	\$ 550
2. Concrete compression: 6x12 cylinders - ASTM C39:	\$ 25
3. Concrete compression: 4x8 cylinders - ASTM C39:	\$ 20
4. Concrete cylinder pickup: 6x12 (>25mi. radius of Lab add hourly pickup rate)	\$ 9.50
5. Concrete cylinder pickup: 4x8 (>25mi. radius of Lab add hourly pickup rate)	\$ 7.50
6. Concrete cylinder mold (w/ lid - spare)	\$ 5
7. Concrete core compression test - ASTM C42	\$ 35
8. Concrete Trial Batch (includes 6 compression tests)	\$765
9. Concrete Mix Design Review (excludes testing & revisions)	\$230
10. Concrete mix proportion revision	\$150
11. Density of concrete cylinder (unit weight)	\$64
12. Drying shrinkage - ASTM C157 (set of 3, 5 ages)	\$495
13. End preparation of cores, diamond sawing, per cut	\$15
14. Flexural beam pick-up (>25mi. radius of Lab add hourly pickup rate)	\$38 ea
15. Flexural strength, 6"x6" beam - ASTM C78 & C293	\$78
16. Shotcrete/Gunite core compression test (not including coring)	\$35
17. Coring of Shotcrete/Gunite panel in laboratory, each core	\$50
18. Shotcrete/Gunite panel pick-up (>25mi. radius of Lab add hourly pickup rate)	\$38
19. Lab. trial batch, not including specimen tests - ASTM C192	Per Quote
20. Lightweight, insulating concrete compress, 4 req. - ASTM C495	\$50
21. Lightweight insulating concrete unit weight (oven dry)	\$95
22. Modulus of elasticity, 6"x12" cylinder - ASTM C469	\$215
23. Petrographic analysis of hardened concrete - ASTM C856	Per Quote
24. Poisson's Ratio on 6"x12" cylinders - ASTM C469	Per Quote
25. Splitting tensile - ASTM C496	\$75
26. Non-Shrink (Dry-Pack) Grout - 2"x2"x2"; set of 3	\$96

C Masonry

1. Absorption - brick, 5 required - ASTM C67	\$ 75
2. Absorption - masonry unit, 3 required - ASTM C140	\$ 45
3. Compressive strength, brick, 5 required - ASTM C67	\$ 45
4. Compression - masonry core	\$ 35
5. Compression - masonry prisms 8"x 8" - ASTM E447 (other sizes by quote - may require cutting charge)	\$ 145
6. Compression - masonry unit, 3 required - ASTM C140 (requires absorption/unit weight tests for Net Area)	\$ 65
7. Dimensions - masonry unit, 3 required	\$ 40
8. Masonry Prism Pickup	\$ 29
9. Masonry Unit Acceptance Test - ASTM C140 (includes absorption, compression, dimensions, unit weight)	\$ 585
10. Compression test, grout specimens	\$ 30
11. Compression test, mortar specimens	\$ 25
12. Diamond sawing of masonry specimens, if required (minimum)	\$ 24
13. Efflorescence, first unit @ \$125, each additional @	\$ 54
14. Linear shrinkage, masonry unit, 3 required - ASTM C426	\$ 98
15. Modulus of rupture, brick, 5 required - ASTM C67	\$ 42
16. Moisture content - masonry unit (as received), 3 req'd - ASTM C140	\$ 42
17. Shear test on masonry core - CBC 2105A.4	\$ 85
18. Tensile test on masonry block	\$ 190
19. Unit weight, masonry unit, 3 required - ASTM C140	\$ 45
20. Visual Examination & Photo-document Core - CBC 2105A.4	\$ 35

V. LAB TESTS: REINFORCING & STRUCTURAL STEEL

A General Testing

1. Processing mill certification (each size & heat)	\$18 ea.
2. Rockwell or Brinell Hardness, average of three readings	\$24 ea.
3. Zinc coating, each item (includes Haz Mat Fee)	\$187

B Reinforcing Steel

1. Deformation, reinforcing steel	\$40
2. Pre-stress, strand or wire, tensile & elongation	Per Quote
3. Proof test on post-tension assembly	Per Quote
4. Bend Test (rebar)	\$45
5. Tensile test (rebar), up to & including #8	\$45
6. Tensile test (rebar) #9, #10, #11	\$60
7. Tensile test (rebar) #14, #18	\$160
8. Rebar Mechanical Coupler (Tension) Test (up to #11 bar)	\$125

Not Project Related

Project #13-154

C. Structural Steel

1. Cutting & machining charges	cost + 15%
2. Bend test, structural, all sizes	\$55
3. Tensile test, structural, <3/4" cross-section (cutting & machining extra)*	\$75
4. Tensile test, structural, >3/4" cross-section (cutting & machining extra)*	\$95
5. Flattening test of pipe	\$42

*Tensile and yield by percent offset, add \$85

D. High Strength Bolts

1. DSA-Certified High Strength Bolt Set ea. (Bolt, Nut, & Washer)	\$ 335
2. Bolts - proof load (non-DSA)	\$ 45
Bolts - ultimate load	\$ 65
Bolts - hardness	\$ 35
3. Nuts - proof load	\$ 45
Nuts - hardness	\$ 35
4. Washers - hardness	\$ 35

F. Welding Procedure and Welder Qualification Tests

<i>Coupon thickness (mild steel only)</i>		<i>to 3/8"</i>	<i>over 3/8"</i>
1. Fracture bend (fillet)		\$45	
2. Macroetch	\$55 ea.		
3. Free bend		\$65	
4. Nick break	\$45 ea.	\$35	
5. Side, face or root bend	\$28 ea.	\$35	
6. Tensile	\$40 ea.	\$50	
7. Welder Qualification Records		\$115	

Includes evaluation of test specimens and preparation of Stamped

Welder/Procedure Qualification Records per applicable code

**Welder qualification examinations are given in our laboratory or at fabricator's shop with 4-hour minimum witnessing charge.*

***Fees listed are for tests only. Sample preparation, coupon machining, etc., will be charged at applicable hourly lab rates and cost plus 15%, for Outside Direct Costs.*

VI. MISCELLANEOUS CONSTRUCTION MATERIALS TESTS

1. Calibration Certificates	Per Quote
2. Density of Sprayed Fireproofing	\$70
3. Fireproofing Bond Pull Test	\$38
4. Roof Tile Strength	\$54
5. Roof Tile Absorption	\$38
6. Roof Cut Tests (total weight only)	\$57
7. Ply count, separation, bituminous content, etc.	Per Quote
8. Jobsite Trailer or Mobile Laboratory	Per Quote
9. Universal Testing Machine (Hourly)	\$150
10. Ground Rod Test (plus travel)	\$150

ADDITIONAL TESTS: BTC LABS and NV5 perform a broad spectrum of field and laboratory testing. This Fee Schedule list only the most common tests performed. For information regarding additional testing services, please contact our laboratory.

VII. ASPHALT & ASPHALTIC CONCRETE

A. Asphalt Pavement Engineering

1. CALTRANS Third Party Resolution Documentation Fee	\$350
2. Pavement Evaluations	\$425 (minimum)

B. Asphaltic Cements And Liquid Asphalts

1. Absolute viscosity @140°F - ASTM D-2171, AASHTO T-202	\$155
Other temperature	\$185
2. Cone penetration - ASTM D-217	\$125
3. Flash point Cleveland Open Cup - ASTM D-92, AASHTO T-48	\$125
4. Kinematic viscosity @140 or 275°F - D-2170, T-201	\$125
Other temperature	\$155
5. Penetration - ASTM D-5, AASHTO T-49 (at 77°F)	\$115
Other temperature	\$135
6. Softening point - ASTM D-36	\$125
7. Solubility in trichloroethylene - ASTM D2042, AASHTO T-44	\$185
8. Specific gravity - ASTM D-70, AASHTO T-228	\$125

C. Emulsions And Slurry Seals

1. Cement mixing - ASTM D-244, AASHTO T-59	\$105
2. Consistency test - ASTM D-3910	\$95
3. Demulsibility - ASTM D-244, AASHTO T-59	\$115
4. Miscibility - ASTM D-244	\$115
5. Particle charge - ASTM D-244, AASHTO T-59	\$75
6. pH determination	\$75
7. Oven cook off (% residue)	\$100
8. Set time - ASTM D-3910	\$85
9. Settlement, 5 or 7 day - ASTM D-244, AASHTO T-59	\$155
10. Slurry seal mix proportion	\$1,750
11. Solids content by evaporation and extraction (slurry)	\$205
12. Storage stability, 1 day - ASTM D-244	\$150
13. Functional Recovery	\$125
14. Wet Track Abrasion - ASTM D-3910 (prep. not included)	\$270

D. Asphaltic Concrete, Aggregate And Mixes

1. Bulk Specific Gravity (max density, bulk AC) CTM 308, AASHTO T166	
3 pt. LTMD	\$210
5 pt. LTMD	\$325
2. Coring of asphaltic concrete - See Section E Diamond Coring	
3. Extraction, % bitumen and sieve analysis	
Solvent Extraction Method - ASTM D2172	\$325
Ignition Oven Method - CTM 382, 202	\$225
4. Extraction, % bitumen only	
Solvent Extraction Method - ASTM 2172	\$265
Ignition Oven Method - CTM 382	\$145
5. Film stripping - CTM 302	\$165
6. Ignition Oven Correction Factor - CTM 382	\$650
7. Marshall - Stability and flow (core) - ASTM D-1559	\$125
8. Marshall - Stability and flow (bulk) - ASTM D-1559	\$325
9. Marshall - Specific Gravity	\$225
10. Mix proportion - Marshall Method	\$2,900
with R.A.P.	\$3,700
11. Mix proportion - HVEEM Method	\$2,700
with R.A.P.	\$3,500
12. Theoretical Maximum Specific Gravity (RICE) - ASTM D-2041	\$200
13. Moisture content - ASTM D-1461	\$115
14. Recovery of Extracted Asphalt (extraction only) - ASTM D-5404	\$250
15. Recovery of rubber from ARHM extraction	\$115
16. Specific gravity of core - ASTM D-2726	\$60
17. HVEEM Stabilometer test on premixed sample - CTM 366	\$185
Stabilometer test and mixing of sample	\$400
18. Surface abrasion CTM 360	\$445
19. Swell test in conjunction with stabilometer - CTM 305	\$115
20. Resistance to Moisture Induced Damage (untreated) - T-283, CT 371	\$1,700
21. Resistance to Moisture Induced Damage (lime) - T-283, CT 371	\$1,850
22. Viscosity curve for ARHM (% rubber) binder blend - 6 hr.	\$870
- 8 hr.	\$1,200

NOTE: Where prices are listed for mix proportions, the necessary specific gravity tests and sieve analyses are included; however, aggregate and asphalt qualification tests are not.

Not Project Related

Project #13-154

II. Consultant may utilize subcontractors as permitted in the Agreement and the WAL. The hourly rate for any subcontractor shall be consistent with the rate and fee schedule indicated in Section I above, unless other direction is provided with written authorization from District Superintendent or his/her designee.

III. Claims for reimbursable expenses shall be documented by appropriate invoices and supporting receipts. Consultant may be reimbursed for those reasonable out-of-pocket expenses set forth below that are incurred and paid for by Consultant beyond the typical obligations under this Agreement and the WAL, but only to the extent that such expenses are directly related to Services satisfactorily completed, are approved by District in writing and do not cause the amounts paid to Consultant to exceed the amounts allowed under this Agreement and the WAL. No mark-up of any expense is permitted. The following is the EXCLUSIVE list of reimbursable expenses:

A. Travel and Mileage. Consultant must request the travel in writing and justify why the travel should be reimbursed. Travel expenses must be approved in writing by District, in its sole discretion. Trips from any Consultant's office to District's office or to the subject project site will not be approved for reimbursement.

B. Reimbursable Reprographic Services. Print sets or copies requested in writing by District beyond the quantities required under the WAL.

C. Fees for Subcontractors. Fees for subcontractors hired and paid by Consultant at the written request of District and are permitted in the Agreement and the WAL.

D. Fees advanced for securing approval of public agencies having jurisdiction over any project hereunder.

IV. Consultant shall provide to District a complete Schedule of Values (SOV), identifying major work activities required to complete the authorized scope of work. All invoices must reflect the appropriate progress percentage for each SOV item billed, to be verified by District. District will compensate Consultant for the Services performed upon approval by District of a valid and complete invoice, in form and substance acceptable to District. See Exhibit G for required Invoice Approval Form and Billing Cover Sheet. The Billing Cover Sheet shall reflect the approved SOV. In connection with Services that are only partially completed at the time an invoice is paid, notwithstanding any provision of the Agreement, the WAL, or any other document, payment of the invoice does not constitute acceptance of the partially completed work or Service. Each invoice is to include:

A. Billing Cover Sheet/SOV with all appropriate progress percentages identified toward completion of the Services.

B. Acceptable back-up for billings shall include, but not be limited to:

- a. Records for all personnel describing the work performed, the number of hours worked, and the hourly rate, for all time charged to the Services.**
- b. Records for all supplies, materials and equipment properly charged to the Services.**
- c. Records for all travel pre-approved by District and properly charged to the Services.**
- d. Records for all subcontractor labor, supplies, equipment, materials, and travel properly charged to the Services.**

Unless otherwise directed by District, in writing, completed invoices are to be submitted to the attention of the Director of Purchasing and the Assistant Superintendent, Business and Fiscal Services. To be considered complete, the invoice packet shall include all back-up documentation required by District and sign-off from District staff, Program Manager or project manager assigned by District to supervise the Services.

Not Project Related

Project #13-154

V. The total compensation for the Services shall be provided for in the WAL(s) issued subsequent to this Agreement.

VI. Compensation Upon Termination. In the event that District suspends or terminates this Agreement, the WAL or any of the Services pursuant to Section 11 or Section 12a of the Agreement, District will pay Consultant as provided herein and the WAL for all Services and authorized Additional Work actually performed, and all authorized reimbursable expenses actually incurred and paid, under and in accordance with this Agreement and the WAL, up to and including the date of suspension or termination; provided that such payments shall not exceed the amounts specified in the Agreement and the WAL as compensation for the Services completed, plus any authorized Additional Work and authorized reimbursable expenses completed prior to suspension or termination. No payment for demobilization shall be paid unless District at its sole discretion determines that demobilization or other compensation is appropriate. After a notice of termination is given, Consultant shall submit to District a final claim for payment, in the form and with certifications prescribed by District. Such claim shall be submitted promptly, but in no event later than forty (40) calendar days after the Termination Date specified on the notice of termination. Such payment shall be Consultant's sole and exclusive compensation and District shall have no liability to Consultant for any other compensation or damages, including without limitation, anticipated profit, prospective losses, legal fees or costs associated with legal representation or consequential damages, of any kind.

- Not Project Related
 Project #13-154

EXHIBIT C
TO AGREEMENT FOR CONSULTANT SERVICES #13-154

INSURANCE

I. **Insurance Requirements.** Consultant shall provide and maintain insurance, acceptable to District Superintendent or District Counsel, in full force and effect throughout the Term of this Agreement and the WAL, against claims for injuries to persons or damages to property which may arise from or in connection with the performance of the work hereunder by Consultant, its agents, subcontractors, representatives and/or employees. Insurance is to be placed with insurers authorized to conduct business in the State of California and with a current A.M. Best's rating of no less than A, as rated by the current edition of Best's Key Rating Guide, published by A.M. Best Company, Oldwick, New Jersey 08858. Consultant shall provide the following scope and limits of insurance:

A. **Minimum Scope of Insurance.** Coverage shall be at least as broad as:

- (1) Commercial General Liability coverage of not less than two million dollars (\$2,000,000) aggregate and one million dollars (\$1,000,000) per occurrence.
- (2) Auto liability insurance with limits of not less than one million dollars (\$1,000,000).
- (3) Insurance coverage should include:
 1. owned, non-owned and hired vehicles;
 2. blanket contractual;
 3. broad form property damage;
 4. products/completed operations; and
 5. personal injury.
- (4) Workers' Compensation insurance as required by the laws of the State of California.
- (5) Abuse and Molestation coverage of not less than two million dollars (\$2,000,000) per occurrence and five million dollars (\$5,000,000) aggregate.
- (6) Professional liability (Errors and Omissions) insurance, including contractual liability, as appropriate to the Consultant's profession, in an amount of not less than the following:

Accountants, Attorneys, Education Consultants, Nurses, Therapists	\$1,000,000
Architects	\$1,000,000 or \$2,000,000
Physicians and Medical Corporations	\$5,000,000

Failure to maintain professional liability insurance is a material breach of this Agreement and the WAL and grounds for immediate termination

II. **Other Provisions.** Insurance policies required by this Agreement shall contain the following provisions:

Not Project Related

Project #13-154

A. All Policies. Each insurance policy required by this Agreement shall be endorsed and state the coverage shall not be suspended, voided, cancelled by the insurer or either Party to this Agreement, reduced in coverage or in limits except after 30 days' prior written notice by Certified mail, return receipt requested, has been given to District

B. General Liability, Automobile Liability, and Abuse/Molestation Coverages.

(1) District, and its respective elected and appointed officers, officials, employees and volunteers are to be covered as additional insureds (collectively, "additional insureds") as respects the following: liability arising out of activities and/or Services Consultant performs; products and completed operations of Consultant; premises owned, occupied or used by Consultant; automobiles owned, leased, hired or borrowed by Consultant, and Abuse/Molestation. The coverage shall contain no special limitations on the scope of protection afforded to additional insureds.

(2) Each policy shall state that the coverage provided is primary and any insurance carried by any additional insured is in excess to and non-contributory with Consultant's insurance.

(3) Consultant's insurance shall apply separately to each insured against whom claim is made or suit is brought, except with respect to the limits of the insurer's liability.

(4) Any failure to comply with the reporting or other provisions of the policies including breaches of warranties shall not affect coverage provided to any additional insured.

III. Other Requirements. Consultant agrees to deposit with District, at or before the effective date of this Agreement and the WAL, certificates of insurance necessary to satisfy District that the insurance provisions of this Agreement have been complied with. District may require that Consultant furnish District with copies of original endorsements effecting coverage required by this section. The certificates and endorsements are to be signed by a person authorized by that insurer to bind coverage on its behalf. District reserves the right to inspect complete, certified copies of all required insurance policies, at any time.

A. If any Services are performed by a subcontractor, Consultant shall furnish certificates and endorsements from each subcontractor identical to those Consultant provides.

B. Any deductibles or self-insured retentions must be declared to and approved by District. At the option of District, either the insurer shall reduce or eliminate such deductibles or self-insured retentions as respects District or its respective elected or appointed officers, officials, employees and volunteers or the Consultant shall procure a bond guaranteeing payment of losses and related investigations, claim administration, defense expenses and claims.

C. The procuring of any required policy or policies of insurance shall not be construed to limit Consultant's liability hereunder nor to fulfill the indemnification provisions and requirements of this Agreement.

- Not Project Related
- Project #13-154

EXHIBIT D
TO AGREEMENT FOR CONSULTANT SERVICES #13-154

CONFLICT OF INTEREST CHECK

Bylaws of the Board 2030(C)E requires that the Superintendent or a designee make a determination, on a case by case basis, concerning whether disclosure will be required from a consultant to comply with District's Conflict of Interest Code (commencing with Bylaws of the Board 2030 BB).

Consultants are required to file disclosures when, pursuant to a contract with District, Consultant will make certain specified government decisions or will perform the same or substantially the same duties for District as a staff person would.

The services to be performed by Consultant under the Agreement to which this Exhibit D is attached constitute do not constitute governmental decisions or staff services within the meaning of the Conflict of Interest Code. Therefore, Consultant, is is not subject to disclosure obligations.

Date: 11-20-13

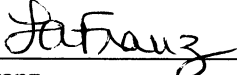
By: 
Lisa A. Franz
Director, Purchasing

Not Project Related

Project #13-154

**EXHIBIT “E”
TO AGREEMENT FOR CONSULTANT SERVICES #13-154**

**BACKGROUND CHECK AND FINGERPRINTING PROCEDURES
FOR CONTRACTORS**

The successful Bidder will be required to assure that its employees, subcontractors of any tier, material suppliers, and consultants do not have direct contact with the District’s students during the performance of the Contract in compliance with Education Code §§ 45125.1 and 45125.2. To assure these provisions, the successful Bidder’s supervisor shall be fingerprinted, and proof of same shall be provided to the District prior to start of on-site work. The supervisor will monitor the workers’ conduct while on school grounds. In addition, the successful Bidder shall barricade the Work area to separate its workers from the students. Costs associated with this process are the responsibility of the successful Bidder.

The Contractors’ construction supervisors or their unsupervised employees who will be working outside of fenced areas during the school hours **must** have submitted a fingerprint identification card to the Department of Justice (DOJ) and have a proof of clearance in the form of an affidavit filed in the Oxnard School District’s Purchasing Office **prior to** the start of the Work.

California Education Code §§45125.1 and 45125.2 require that criminal checks be completed for contractors (Contracting Firm) who provide architectural, construction, janitorial, administrative, landscape, transportation, food-related, or other similar services to school districts.

The undersigned does hereby certify to the Board of Trustees of the Oxnard School District as follows:

That I am a representative of the Contractor currently under contract (“Contract”) with the District; that I am familiar with the facts herein certified, and am authorized and qualified to execute this certificate on behalf of Contractor.

Contractor certifies that it has taken the following actions with respect to the construction Project that is the subject of the Contract:

1. Pursuant to Education Code §45125.2, Contractor has installed or will install, prior to commencement of Work, a physical barrier at the Work Site, which will limit contact between Contractor’s employees and District pupils at all times (mandatory for all Projects); AND
2. The Contractor has complied with the fingerprinting requirements of Education Code §45125.1 with respect to all Contractor’s employees and all of its subcontractors’ employees who may have contact with District pupils in the course of providing services pursuant to the Contract, and the California Department of Justice has determined that none of those employees has been convicted of a felony, as that term is defined in Education Code §45122.1. A complete and accurate list of Contractor’s employees and of all its subcontractors’ employees who may come in contact with District pupils during the course and scope of the Contract is attached hereto; AND/OR

Not Project Related

Project #13-154

3. Pursuant to Education Code §45125.2, Contractor certifies that all employees will be under the continual supervision of, and monitored by, an employee of the Contractor who the California Department of Justice has ascertained has not been convicted of a violent or serious felony. The name and title of each employee who will be supervising Contractor's employees and its subcontractors' employees is:

Name: Scott Moors

Title: President

AND/OR

4. The Work on the Contract is at an unoccupied school site and no employee and/or subcontractor or supplier of any tier of Contract shall come in contact with District pupils.

Contractor's responsibility for background clearance extends to all of its employees, Subcontractors, and employees of Subcontractors coming into contact with District pupils regardless of whether they are designated as employees or acting as independent contractors of the Contractor.

Date: 10-30-2013

Proper Name of Contractor: BTC LABS - Vertical Five

Signature: 

By: Scott Moors

Its: _____

Not Project Related

Project #13-154

**EXHIBIT “F”
TO AGREEMENT FOR CONSULTANT SERVICES #13-154**

SCOPE OF SERVICES – Materials Testing Laboratory & Special Inspections

The Materials Testing Laboratory & Special Inspector’s Scope of Work includes, but is not limited to, the following:

Consultant shall ensure that the materials, means, and methods utilized in the field are in accordance with DSA approved design documents and Title 24 and its referenced standards. Consultant shall be responsible for verifying that such materials are manufactured, fabricated, assembled, and constructed in accordance with the approved design.

1. Qualifications and Special Inspection Services:

- a. The geotechnical portions of this project shall be performed under the direction of a Geotechnical Engineer, which shall be the Geotechnical Engineer of Record for the geotechnical portions of this project shall be performed under the direction of a Geotechnical Engineer, which shall be the Geotechnical Engineer of Record for the project. A technician with a nuclear gauge shall perform density and moisture testing in the field during grading, utility trench backfilling, and pavement operations utilizing ASTM D2922, D3017, and ASTM D1556 methods. Laboratory maximum density and optimum moisture determination shall be performed in accordance with ASTM D1557 or D698. Asphalt pavement placement and testing shall be performed in accordance with Caltrans methods.

2. General Scope of Services:

- a. Perform a site reconnaissance, review the geotechnical engineering report for the Project, review the drawings, and prepare a transfer of geotechnical engineer of record responsibility letter.
- b. Project management, consultation during construction, and preparation of daily field, foundation excavation observation, and final grading reports.
- c. Ensure that soils conditions are in conformance to soils report.
- d. Foundation inspection.
- e. Caisson, drilled piers or driven piles inspection.
- f. As-graded soils reports.
- g. Observations and testing during site clearing and mass grading.
- h. Observing the foundations excavations for structures.
- i. Observation and testing during backfilling of utility trenches.
- j. Observation and testing during backfilling around retaining walls.
- k. Observation and testing during subgrade preparation and base rock placement in asphalt paved areas.
- l. Observation and testing during asphalt concrete placement.

Not Project Related

Project #13-154

m. Perform the Sampling and Testing of Materials and Testing of Work-in-Place as may be required by the DSA Testing and Inspection Listing, and as required by the DISTRICT. The Testing shall be performed in accordance with ASTM test methods and California test methods as appropriate. All Laboratory testing shall be accomplished in a DSA-certified laboratory. The required testing and special inspection shall include, but not be limited to:

i. Soil, Aggregate & Asphalt

- Maximum Dry Density
- Expansion Index (ASTM D4318)
- R-Value
- Sand Equivalent
- Sieve Analysis (ASTM C136)
- Hveem Stability
- Asphalt Extraction (ASTM 2172)
- Hardness and Abrasion
- Atterberg limits (ASTM 4318)
- No. 200 Sieve Analysis (ASTM D422)
- Specific Gravity C127/C128
- Asphalt and Asphaltic Concrete Gradation (ASTM C136)
- Asphalt and Asphaltic Concrete Specific Gravity (ASTM D1 188)
- Asphalt and Asphaltic Concrete Stability & Flow Marshall (ASTM D1 559)
- Asphalt and Asphaltic Concrete Abrasion (ASTM C131)
- Asphalt and Asphaltic Concrete Unit Weight (ASTM D2726)
- Asphalt Cores

3. Observation and Testing:

a. Observation and testing shall consist of visual observation of earthwork activities and taking field density and moisture tests for the purpose of ascertaining that the work is in substantial conformance with the contract documents. Such observation and testing shall not be relied upon by others as acceptance of the work nor shall it be construed to relieve the contractor in any way from the contractor's obligation and responsibilities under the construction contract. Specifically, but without limitations, observation and testing shall not require the technician and engineer to assume responsibilities for the means and methods of construction nor for safety on the jobsite. Consultant's performance of its work shall not result in safety hazards on the site.

4. Concrete Mix Design Review:

- a. *Types of Inspection Services Provided.* Inspection services shall be provided for concrete, prestressed concrete, reinforcing steel and prestressing steel, batch plant, insulating concrete, lightweight concrete, field sampling (slump, air entertainment, unit weight and yield tests), concrete coring, proof testing (installed epoxy & non-shrink grout bolts) and proof testing (installed wedge and expansion anchors).
- b. *Laboratory Review.* The Consultant shall review the proposed concrete mixes in its laboratory for conformance with the specifications.
- c. *Tests to be Performed.* The Consultant shall perform the following tests:
- i. Concrete Compression Tests

Not Project Related

Project #13-154

- Concrete Cylinders (ASTM C29)
- Concrete Cores (ASTM C39)
- Lightweight Concrete (ASTM C495)
- Insulating Concrete (ASTM C332)
- ii. Concrete Flexural Tests
 - Flexural Test (ASTM C2931C78)
- iii. Steel Reinforcing
 - Tensile (ASTM A61 5)
 - Bend (ASTM A61 5)
- iv. Concrete Aggregate
 - Conformance Test (ASTM C33)
(Sieve Analysis, Deleterious Substances & Soundness)

5. Reinforcing Steel Placement:

- a. Prior to the pours, the consultant shall inspect the reinforcing steel placement to determine that it is according to plans and specifications. The consultant shall check:
 - i. *Bars.* Size and spacing of bars.
 - ii. *Splices.* Location and length of splices.
 - iii. *Clearances.* Check clearances.
 - iv. *Cleanliness of Bars.* Observe cleanliness of bars.
 - v. *Spacing tolerances.* Confirm spacing tolerances.
 - vi. *Steel Support.* Proper support of steel with ties.

5. Concrete Placement:

- a. During the pours, the Consultant shall be on site continuously, as required by code, to monitor placement. The Consultant shall:
 - i. *Bar Displacement* Determine that no bars are displaced during the pouring.
 - ii. *Cleanliness of Steel.* Observe cleanliness of steel.
 - iii. *Placement.* Determine adequacy of placement and vibratory equipment.
 - iv. *Delivery Rate.* Determine proper delivery rate of concrete and monitor batch times.
 - v. *Correct Mix.* Determine that the correct mix is being utilized.
 - vi. *Slump.* Monitor slump of each truck.
 - vii. *Temperature.* Record temperature of air and concrete.
 - viii. *Cast Cylinders.* Cast cylinders for compression tests at the specified frequency.
 - ix. *Air Checks.* Perform air checks, if required by specifications, during concrete placement.
 - x. *Anchor Bolt/Dowel Installation.* Observe anchor bolt/dowel installation operations to determine hold depth, embedment and cleanliness, as well as materials and workmanship. The Consultant shall inspect to determine that all dowels are installed in accordance with contract documents and/or manufacturer's requirements.

Not Project Related

Project #13-154

6. Compression Testing:

- a. The consultant shall transport all samples to CONSULTANT'S laboratory for compression testing in strict accordance with ASTM requirements. The CONSULTANT shall distribute compression test reports to the appropriate parties.

7. Mix Design Review:

- a. *Grout and Mortar Mixes.* The CONSULTANT shall review the proposed grout and mortar mixes in CONSULTANT'S laboratory for conformance with the specifications.
- b. *Masonry Wall Prisms.* During preparation of masonry wall prisms, sampling and placing of all masonry units, placement of reinforcement, and inspection of grout space immediately prior to closing or cleanouts and during all grouting operations.
- c. *Laboratory Tests.* Laboratory tests shall include:
- i. Masonry Compression Tests
 - Mortar (UBC 21 - 16)
 - Grout (UBC 21 - 18 | ASTM GI 01 9)
 - Masonry Prism (ASTM E447)
 - Masonry Cores (ASTM C42)
 - Shear Tests - Masonry Cores (UBC 2405(c)4.C)
 - Dry Shrinkage - Masonry Units (ASTM C426)
 - Sample Pick-up & Delivery
 - ii. Steel Reinforcing
 - Tensile (ASTM A61 5)
 - Bend (ASTM A61 5)
 - Steel Tagging, Pick-up and Delivery
 - iii. Concrete Aggregate
 - Conformance Test (ASTM C404)
(Sieve Analysis, Deleterious Substances and Soundness)

8. Duties:

- a. The consultant's duties shall include the following:
- i. Review mill test certifications of block and reinforcing steel.
 - ii. Inspect to determine size and spacing of dowels.
 - iii. Inspect to determine that cleanouts are provided for high-lift grouting methods.
 - iv. Inspect proper lay-up of block units.
 - v. Inspect reinforcing steel prior to grouting.
 - vi. Inspect dowels, anchor bolts and inserts to make sure they are in place and properly secured prior to grouting.
 - vii. Inspect to determine proper consolidation of grout.
 - viii. Check that curing requirements are being followed.

9. Structural Steel:

- a. *Inspection Services.* The CONSULTANT shall provide inspection services for the following:
- i. Field Welding
 - ii. High Strength Bolting

Not Project Related

Project #13-154

- iii. Metal Decking
 - iv. Welded Stud Connectors
 - v. Fabrication Shop
- b. *Non-Destructive Examinations, Fabrication, Field Testing.* The CONSULTANT shall provide the following Non-Destructive Examinations (Field Testing) in strict conformance with ASTM standards:
- i. Ultrasonic Examination
 - ii. Magnetic Particle Examination
 - iii. Liquid Penetrant Examination
 - iv. Radiographic Examination
- c. *Non-Destructive Examinations, Fabrication Shop Testing.* The CONSULTANT shall provide the following Non-Destructive Examinations (Fabrication Shop Testing):
- i. Ultrasonic Examination
 - ii. Magnetic Particle Examination
 - iii. Liquid Penetrant Examination
 - iv. Radiographic Examination
- d. *Laboratory Tests.* Laboratory tests shall be performed on the following:
- i. High strength bolts
 - ii. Hardness Test (ASTM A325)
 - iii. Tensile Strength (ASTM F606)

10. Reports

As part of the Services, Consultant will prepare and deliver the following tangible work products to District:

- a. All DSA required inspections, reporting, processes and procedures required by the DSA Testing & Inspection Listing, and/or required by the Architect of Record.

11. Time

All DSA required reporting shall be delivered to the District concurrent with the submittal to DSA, and pursuant to DSA required timelines. The final inspection report (DSA Form 6) shall be completed and electronic filed within 30 calendar days of the notice of completion.

12. Accuracy Standards

Precision of the soils and materials testing and inspection reports and recommendations shall be in accordance with the professional standard of care to be expected of professional engineers, geologists, and inspectors licensed to practice in the State of California, and acceptable to the Architect of Record and the Division of State Architect.

- Not Project Related
 Project #13-154

Consultant/Vendor Billing Instructions

Invoice Cover Sheet Set-Up.

- 1 See "Billing tab" below for spreadsheet, these are the instructions
- 2 Enter Project Site name, DSA project number, Project Type, Invoice #, Date, Your Company Name, fax, phone, etc...
- 3 Enter PO # (Purchase Order #) provided to you when contract issued.
- 4 Feel free to include your company logo if you wish
- 5 Enter approved contract agreements, amendments, re-imbursables, allowances, etc. for which you are billing. Include summary scope of work. Enter "Cost Code" provided to you by Program Manager.
- 6 If you wish to break the contract work items down into portions that you would typically separate for progressive payments, please do that now. If your contract allows re-imbursables in addition to contract fee, please separate these values. If you require more line items to complete this step, please highlight the entire last row by clicking on the grey row # at left, press CTRL+C to copy row, right click grey row # immediately below, select "Insert Copied Cells". This can be repeated as many times as necessary. Multiple rows can be copied/inserted in a single step by highlighting multiple rows prior to copying.

First Billing.

- 5 **IMPORTANT!** When you are entering costs for your first billing, enter values (dollar amounts) ONLY into the green column. The percentages will change automatically. **NOTE:** Select the (% Complete) billing tab if you prefer to track your billings based on total project % complete. Once % complete is entered, billable amount will populate automatically. Select the (lump sum) billing tab if you prefer to track your billings as a lump sum billable amount to date. Once lump sum amount is entered, % complete will populate automatically.
- 6 Send invoice based on the Dollar value at the PRE-RETENTION value, if applicable.

Subsequent Billings

- 7 Manually input the dollar values from the "cost completed to date" column into the blue "total previous billings" column
- 8 Enter the corresponding dollar values;% complete values into the green column for total work complete to date.
- 9 Submit a conditional release waiver with the billing. Submit signed pay request certification form.
- 10 Email (tmiddlestadt@cfwinc.com), or mail to the CFW Oxnard office at 1901 Victoria Ave, Suite 106 Oxnard, CA 93035. Please allow 4-6 weeks for invoice processing prior to payment.
- 11 Please note that invoice amounts which exceed remaining contract balance will not be processed, and will be returned to Vendor pending additional contract agreement(s). Incorrect contract amounts, cost codes, or other errors & miscalculations can delay/prevent processing of payment.

NOTE: All Consultant/Vendor invoices must be accompanied by this worksheet to ensure proper payment. Invoices without this worksheet may be rejected and may delay payment until the next billing cycle or until the spreadsheet becomes accurate. Invoices not received by the 25th may be delayed until the next billing cycle. Contact the Program Manager with any questions regarding billing values, or any other information required, prior to submitting a billing.

Cavignac & Associates

INSURANCE BROKERS
License No. OA99520

450 B Street, Suite 1800
San Diego, CA 92101-8005

Phone 619-234-6848
Fax 619-234-8601
Web Site www.cavignac.com

Oxnard School District
ATTN: Lisa Franz
1051 South A Street
Oxnard, CA, 93030

Oct 30, 2013

Re: NV5/Nolte Associates, Inc.

To Whom It May Concern:

Enclosed is a certificate of insurance, as requested. If you have questions or require changes, please contact our office via email (certificates@cavignac.com) or fax (619-234-1239). Please include a copy of the certificate with your request or reference ID number 243844.

Sincerely,

Cavignac & Associates Certificate Department
certificates@cavignac.com
619-234-1239 (fax)

cc: Danielle Wooten (Danielle.Wooten@nv5.com)

Certificate of Insurance for NV5/Nolte Associates, Inc.



CERTIFICATE OF LIABILITY INSURANCE

DATE (MM/DD/YYYY)
10/30/2013

THIS CERTIFICATE IS ISSUED AS A MATTER OF INFORMATION ONLY AND CONFERS NO RIGHTS UPON THE CERTIFICATE HOLDER. THIS CERTIFICATE DOES NOT AFFIRMATIVELY OR NEGATIVELY AMEND, EXTEND OR ALTER THE COVERAGE AFFORDED BY THE POLICIES BELOW. THIS CERTIFICATE OF INSURANCE DOES NOT CONSTITUTE A CONTRACT BETWEEN THE ISSUING INSURER(S), AUTHORIZED REPRESENTATIVE OR PRODUCER, AND THE CERTIFICATE HOLDER.

IMPORTANT: If the certificate holder is an ADDITIONAL INSURED, the policy(ies) must be endorsed. If SUBROGATION IS WAIVED, subject to the terms and conditions of the policy, certain policies may require an endorsement. A statement on this certificate does not confer rights to the certificate holder in lieu of such endorsement(s).

PRODUCER Cavnagac & Associates 450 B Street, Suite 1800 San Diego, CA 92101-8005 License No. OA99520	CONTACT NAME: Certificate Department	
	PHONE (A/C No. Ext): 619-234-6848	FAX (A/C, No): 619-234-8601
E-MAIL ADDRESS: certificates@cavnagac.com		
INSURER(S) AFFORDING COVERAGE		NAIC #
INSURER A: TRAVELERS PROP CAS CO OF AMER		25674
INSURER B: TRAVELERS IND CO OF CT		25682
INSURER C: HUDSON INS CO		25054
INSURER D:		
INSURER E:		
INSURER F:		

COVERAGES **CERTIFICATE NUMBER:** 243844 **REVISION NUMBER:**

THIS IS TO CERTIFY THAT THE POLICIES OF INSURANCE LISTED BELOW HAVE BEEN ISSUED TO THE INSURED NAMED ABOVE FOR THE POLICY PERIOD INDICATED. NOTWITHSTANDING ANY REQUIREMENT, TERM OR CONDITION OF ANY CONTRACT OR OTHER DOCUMENT WITH RESPECT TO WHICH THIS CERTIFICATE MAY BE ISSUED OR MAY PERTAIN, THE INSURANCE AFFORDED BY THE POLICIES DESCRIBED HEREIN IS SUBJECT TO ALL THE TERMS, EXCLUSIONS AND CONDITIONS OF SUCH POLICIES. LIMITS SHOWN MAY HAVE BEEN REDUCED BY PAID CLAIMS.

INSR LTR	TYPE OF INSURANCE	ADDL SUBR INSR WVD	POLICY NUMBER	POLICY EFF (MM/DD/YYYY)	POLICY EXP (MM/DD/YYYY)	LIMITS
B	GENERAL LIABILITY <input checked="" type="checkbox"/> COMMERCIAL GENERAL LIABILITY <input type="checkbox"/> CLAIMS-MADE <input checked="" type="checkbox"/> OCCUR <input checked="" type="checkbox"/> Cross Liab/Sev of Int <input checked="" type="checkbox"/> \$0 Deductible GEN'L AGGREGATE LIMIT APPLIES PER: <input type="checkbox"/> POLICY <input checked="" type="checkbox"/> PROJECT <input type="checkbox"/> LOC	X	6806B97547A	5/1/2013	5/1/2014	EACH OCCURRENCE \$ 1,000,000 DAMAGE TO RENTED PREMISES (Ea occurrence) \$ 100,000 MED EXP (Any one person) \$ 5,000 PERSONAL & ADV INJURY \$ 1,000,000 GENERAL AGGREGATE \$ 2,000,000 PRODUCTS - COMP/OP AGG \$ 2,000,000 Stop Gap Liability \$ 1,000,000
A	AUTOMOBILE LIABILITY <input checked="" type="checkbox"/> ANY AUTO <input type="checkbox"/> ALL OWNED AUTOS <input type="checkbox"/> HIRED AUTOS <input type="checkbox"/> SCHEDULED AUTOS <input type="checkbox"/> NON-OWNED AUTOS	X	BA6B774609	7/1/2013	5/1/2014	COMBINED SINGLE LIMIT (Ea accident) \$ 1,000,000 BODILY INJURY (Per person) \$ BODILY INJURY (Per accident) \$ PROPERTY DAMAGE (Per accident) \$ \$
A	<input checked="" type="checkbox"/> UMBRELLA LIAB <input checked="" type="checkbox"/> OCCUR <input type="checkbox"/> EXCESS LIAB <input type="checkbox"/> CLAIMS-MADE DED <input checked="" type="checkbox"/> RETENTION \$ \$0		CUP4076T902	7/1/2013	5/1/2014	EACH OCCURRENCE \$ 5,000,000 AGGREGATE \$ 5,000,000 \$
A	WORKERS COMPENSATION AND EMPLOYERS' LIABILITY ANY PROPRIETOR/PARTNER/EXECUTIVE OFFICER/MEMBER EXCLUDED? (Mandatory in NH) <input type="checkbox"/> Y/N If yes, describe under DESCRIPTION OF OPERATIONS below	N/A	UB3893T34A	5/1/2013	5/1/2014	<input checked="" type="checkbox"/> WC STATUTORY LIMITS <input type="checkbox"/> OTHER E.L. EACH ACCIDENT \$ 1,000,000 E.L. DISEASE - EA EMPLOYEE \$ 1,000,000 E.L. DISEASE - POLICY LIMIT \$ 1,000,000
C	Professional Liability		AEE7246003	5/1/2013	5/1/2014	Ea Claim \$5,000,000 Aggregate \$10,000,000

DESCRIPTION OF OPERATIONS / LOCATIONS / VEHICLES (Attach ACORD 101, Additional Remarks Schedule, if more space is required)
 Re: Agreement for Consultant Services #13-130. Additional Insured coverage applies to General and Automobile Liability for Oxnard School District, and its respective elected and appointed officers, officials, employees and volunteers per policy form. Primary coverage applies to General and Automobile Liability per policy form. Prof. Liab. - Claims made, defense costs included within limit. Cavnagac & Associates will provide 30 days notice of cancellation to the Certificate Holder in the event of policy cancellation.

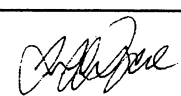
CERTIFICATE HOLDER Oxnard School District 1051 South A Street Oxnard, CA 93030 United States	CANCELLATION <p>SHOULD ANY OF THE ABOVE DESCRIBED POLICIES BE CANCELLED BEFORE THE EXPIRATION DATE THEREOF, NOTICE WILL BE DELIVERED IN ACCORDANCE WITH THE POLICY PROVISIONS.</p> AUTHORIZED REPRESENTATIVE Jeffrey W. Cavnagac 
---	---

© 1988-2010 ACORD CORPORATION. All rights reserved.

THIS ENDORSEMENT CHANGES THE POLICY. PLEASE READ IT CAREFULLY.

BUSINESS AUTO EXTENSION ENDORSEMENT

This endorsement modifies insurance provided under the following:

BUSINESS AUTO COVERAGE FORM

With respect to coverage provided by this endorsement, the provisions of the Coverage Form apply unless modified by the endorsement.

GENERAL DESCRIPTION OF COVERAGE – This endorsement broadens coverage. However, coverage for any injury, damage or medical expenses described in any of the provisions of this endorsement may be excluded or limited by another endorsement to the Coverage Part, and these coverage broadening provisions do not apply to the extent that coverage is excluded or limited by such an endorsement. The following listing is a general coverage description only. Limitations and exclusions may apply to these coverages. Read all the provisions of this endorsement and the rest of your policy carefully to determine rights, duties, and what is and is not covered.

- | | |
|---|---|
| A. BROAD FORM NAMED INSURED | H. HIRED AUTO PHYSICAL DAMAGE – LOSS OF USE – INCREASED LIMIT |
| B. BLANKET ADDITIONAL INSURED | I. PHYSICAL DAMAGE – TRANSPORTATION EXPENSES – INCREASED LIMIT |
| C. EMPLOYEE HIRED AUTO | J. PERSONAL EFFECTS |
| D. EMPLOYEES AS INSURED | K. AIRBAGS |
| E. SUPPLEMENTARY PAYMENTS – INCREASED LIMITS | L. NOTICE AND KNOWLEDGE OF ACCIDENT OR LOSS |
| F. HIRED AUTO – LIMITED WORLDWIDE COVERAGE – INDEMNITY BASIS | M. BLANKET WAIVER OF SUBROGATION |
| G. WAIVER OF DEDUCTIBLE – GLASS | N. UNINTENTIONAL ERRORS OR OMISSIONS |

PROVISIONS

A. BROAD FORM NAMED INSURED

The following is added to Paragraph A.1., **Who Is An Insured**, of **SECTION II – LIABILITY COVERAGE**:

Any organization you newly acquire or form during the policy period over which you maintain 50% or more ownership interest and that is not separately insured for Business Auto Coverage. Coverage under this provision is afforded only until the 180th day after you acquire or form the organization or the end of the policy period, whichever is earlier.

B. BLANKET ADDITIONAL INSURED

The following is added to Paragraph c. in A.1., **Who Is An Insured**, of **SECTION II – LIABILITY COVERAGE**:

Any person or organization who is required under a written contract or agreement between you and that person or organization, that is signed and

executed by you before the "bodily injury" or "property damage" occurs and that is in effect during the policy period, to be named as an additional insured is an "insured" for Liability Coverage, but only for damages to which this insurance applies and only to the extent that person or organization qualifies as an "insured" under the **Who Is An Insured** provision contained in Section II.

C. EMPLOYEE HIRED AUTO

1. The following is added to Paragraph A.1., **Who Is An Insured**, of **SECTION II – LIABILITY COVERAGE**:

An "employee" of yours is an "insured" while operating an "auto" hired or rented under a contract or agreement in that "employee's" name, with your permission, while performing duties related to the conduct of your business.

THIS ENDORSEMENT CHANGES THE POLICY. PLEASE READ IT CAREFULLY.

BLANKET ADDITIONAL INSURED (ARCHITECTS, ENGINEERS AND SURVEYORS)

This endorsement modifies insurance provided under the following:

COMMERCIAL GENERAL LIABILITY COVERAGE PART

A. The following is added to WHO IS AN INSURED (Section II):

Any person or organization that you agree in a "contract or agreement requiring insurance" to include as an additional insured on this Coverage Part, but only with respect to liability for "bodily injury", "property damage" or "personal injury" caused, in whole or in part, by your acts or omissions or the acts or omissions of those acting on your behalf:

- a. In the performance of your ongoing operations;
- b. In connection with premises owned by or rented to you; or
- c. In connection with "your work" and included within the "products-completed operations hazard".

Such person or organization does not qualify as an additional insured for "bodily injury", "property damage" or "personal injury" for which that person or organization has assumed liability in a contract or agreement.

The insurance provided to the additional insured is limited as follows:

- d. This insurance does not apply on any basis to any person or organization for which coverage as an additional insured specifically is added by another endorsement to this Coverage Part.
- e. This insurance does not apply to the rendering of or failure to render any "professional services".
- f. The limits of insurance afforded to the additional insured shall be the limits which you agreed in that "contract or agreement requiring insurance" to provide for that additional insured, or the limits shown in the Declarations for this Coverage Part, whichever are less. This endorsement does not increase the limits of insurance stated in the **LIMITS OF INSURANCE (Section III)** for this Coverage Part.

B. The following is added to Paragraph a. of 4. Other Insurance in COMMERCIAL GENERAL LIABILITY CONDITIONS (Section IV):

However, if you specifically agree in a "contract or agreement requiring insurance" that the insurance provided to an additional insured under this Coverage Part must apply on a primary basis, or a primary and non-contributory basis, this insurance is primary to other insurance that is

available to such additional insured which covers such additional insured as a named insured, and we will not share with the other insurance, provided that:

- (1) The "bodily injury" or "property damage" for which coverage is sought occurs; and
- (2) The "personal injury" for which coverage is sought arises out of an offense committed;

after you have entered into that "contract or agreement requiring insurance". But this insurance still is excess over valid and collectible other insurance, whether primary, excess, contingent or on any other basis, that is available to the insured when the insured is an additional insured under any other insurance.

C. The following is added to Paragraph 8. Transfer Of Rights Of Recovery Against Others To Us in COMMERCIAL GENERAL LIABILITY CONDITIONS (Section IV):

We waive any rights of recovery we may have against any person or organization because of payments we make for "bodily injury", "property damage" or "personal injury" arising out of "your work" performed by you, or on your behalf, under a "contract or agreement requiring insurance" with that person or organization. We waive these rights only where you have agreed to do so as part of the "contract or agreement requiring insurance" with such person or organization entered into by you before, and in effect when, the "bodily injury" or "property damage" occurs, or the "personal injury" offense is committed.

D. The following definition is added to DEFINITIONS (Section V):

"Contract or agreement requiring insurance" means that part of any contract or agreement under which you are required to include a person or organization as an additional insured on this Coverage Part, provided that the "bodily injury" and "property damage" occurs, and the "personal injury" is caused by an offense committed:

- a. After you have entered into that contract or agreement;
- b. While that part of the contract or agreement is in effect; and
- c. Before the end of the policy period.

OSD BOARD AGENDA ITEM

Name of Contributor: Janet Penanhoat

Date of Meeting: 4/3/19

- Study Session:** _____
 - Closed Session** _____
 - A-1. Preliminary** _____
 - A-II. Reports** _____
 - B. Hearings** _____
 - C. Consent Agenda** _____
- Agreement Category:**
- ___ Academic
 - ___ Enrichment
 - ___ Special Education
 - ___ Support Services
 - ___ Personnel
 - ___ Legal
 - X Facilities
- D. Action Items** _____
- F. Board Policies** 1st Reading _____ 2nd Reading _____

Approval of Notice of Completion, Brekke School Kinder/Flex Project (Penanhoat/Fateh/CFW)

The contractor, Viola Inc., has completed the work of Construction Services Agreement #17-209 to perform the work for Brekke School Kinder/Flex Project, as of October 9, 2018, and the project has been closed-out with the Division of the State Architect. It is recommended that the Board of Trustees approve the Notice of Completion for this project, which will be filed by the District with the County Recorder’s Office.

FISCAL IMPACT:

None

RECOMMENDATION:

It is the recommendation of the Assistant Superintendent, Business & Fiscal Services, and the Director of Facilities, in consultation with Caldwell Flores Winters, that the Board of Trustees approve the Notice of Completion and filing of such notice with the County Recorder’s Office, for Construction Services Agreement #17-209 with Viola Inc.

ADDITIONAL MATERIALS:

Attached: Notice of Completion (1 Page)

Return Recorded Notice of Completion to:
Lisa A. Franz
Oxnard School District
1051 South "A" Street
Oxnard, CA 93030

NO FEE PER GOVT CODE 27383

NOTICE OF COMPLETION

Notice is hereby given that the Oxnard School District, a school district in Ventura County, is the owner in fee of the following described real property, to-wit:

Description: Brekke School, 1400 Martin Luther King Jr. Drive, Oxnard, CA 93030, for Construction Services Agreement #17-209, Brekke School Kinder/Flex Project:

That on or about the 1st day of November, 2017 the said Oxnard School District of Ventura County entered into a contract with Viola Inc. for the work of site improvements located at the school site listed above, that certain real property hereinbefore described; that said building(s) and improvements were substantially completed on the 9th day of October, 2018; that the address of said Oxnard School District is 1051 South A Street, City of Oxnard, Ventura County, California 93030.

Oxnard School District

By _____
Secretary of its Board of Trustees

STATE OF CALIFORNIA)
COUNTY OF VENTURA)

Cesar Morales, being first duly sworn deposes and says: that he is Secretary and Clerk of the Board of Trustees of the Oxnard School District, a school district of Ventura County, California; that he therefore verifies the forgoing Notice of Completion on behalf of said Oxnard School District; that the Oxnard School District, of Ventura County, California, is owner of the property described in the forgoing notice; that he has read the forgoing notice and knows the contents thereof; that he has personal knowledge of the facts therein stated; that the same are true.

Subscribed and sworn to (**or affirmed**) before me on this _____ day of _____, 2019, by _____, **proved to me on the basis of satisfactory evidence to be the person(s) who appeared before me.**

OSD BOARD AGENDA ITEM

Name of Contributor: Janet Penanhoat

Date of Meeting: 4/3/19

- Study Session:** _____
Closed Session _____
- A-1. Preliminary** _____
A-II. Reports _____
B. Hearings _____
C. Consent Agenda _____
- Agreement Category:**
____ Academic
____ Enrichment
____ Special Education
____ Support Services
____ Personnel
____ Legal
 X Facilities
- D. Action Items** _____
F. Board Policies 1st Reading _____ 2nd Reading _____

Approval of Notice of Completion, Harrington Early Child Development Center, Bid #17-01 (Penanhoat/Fateh/CFW)

The contractor, Ardalan Construction Co. Inc., has completed the work of Bid #17-01 to perform the work for Harrington Early Child Development Center, as of October 26, 2018, and the project has been closed-out with the Division of the State Architect. It is recommended that the Board of Trustees approve the Notice of Completion for this project, which will be filed by the District with the County Recorder’s Office.

FISCAL IMPACT:

None

RECOMMENDATION:

It is the recommendation of the Assistant Superintendent, Business & Fiscal Services, and the Director of Facilities, in consultation with Caldwell Flores Winters, that the Board of Trustees approve the Notice of Completion and filing of such notice with the County Recorder’s Office, for Bid #17-01, Harrington Early Child Development Center with Ardalan Construction Co. Inc.

ADDITIONAL MATERIALS:

Attached: Notice of Completion (1 Page)

Return Recorded Notice of Completion to:
Lisa A. Franz
Oxnard School District
1051 South "A" Street
Oxnard, CA 93030

NO FEE PER GOVT CODE 27383

NOTICE OF COMPLETION

Notice is hereby given that the Oxnard School District, a school district in Ventura County, is the owner in fee of the following described real property, to-wit:

Description: Harrington School, 451 E. Olive Street, Oxnard, CA 93033, for Bid #17-01, Harrington Early Child Development Center:

That on or about the 6th day of September, 2017 the said Oxnard School District of Ventura County entered into a contract with Ardalan Construction Co. Inc. for the work of site improvements located at the school site listed above, that certain real property hereinbefore described; that said building(s) and improvements were substantially completed on the 26th day of October, 2018; that the address of said Oxnard School District is 1051 South A Street, City of Oxnard, Ventura County, California 93030.

Oxnard School District

By _____
Secretary of its Board of Trustees

STATE OF CALIFORNIA)
COUNTY OF VENTURA)

Cesar Morales, being first duly sworn deposes and says: that he is Secretary and Clerk of the Board of Trustees of the Oxnard School District, a school district of Ventura County, California; that he therefore verifies the forgoing Notice of Completion on behalf of said Oxnard School District; that the Oxnard School District, of Ventura County, California, is owner of the property described in the forgoing notice; that he has read the forgoing notice and knows the contents thereof; that he has personal knowledge of the facts therein stated; that the same are true.

Subscribed and sworn to (**or affirmed**) before me on this _____ day of _____, 2019, by _____, **proved to me on the basis of satisfactory evidence to be the person(s) who appeared before me.**

OSD BOARD AGENDA ITEM

Name of Contributor: **Shristie Nair-Villano**

Date of Meeting: **April 3, 2019**

- A. Preliminary _____
Study Session _____
Report _____
- B. Hearing: _____
- C. Consent Agenda X
Agreement Category:
 - _____ Academic
 - _____ Enrichment
 - _____ Special Education
 - _____ Support Services
 - _____ Personnel
 - _____ Legal
 - _____ Facilities
- D. Action Items _____
- E. Approval of Minutes _____
- F. Board Policies 1st Reading _____ 2nd Reading _____

Establish/Abolish/Increase/Reduce Hours of Position (Nair-Villano)

Establish

a five hour and forty five minute 194 day Campus Assistant position number 9357 to be established at San Miguel School. This position will be established to provide additional support.

a five hour and forty five minute 197 day Paraeducator II position number 9361 to be established in the Special Education Department. This position will be established to provide additional support.

a five hour and forty five minute 197 day Paraeducator II Bilingual position number 9358 to be established in the Special Education Department. This position will be established to provide additional support.

a one hour 197 day Paraeducator III position number 16520 to be established in the Special Education Department. This position will be established to provide additional support.

a one hour and fifteen minute 197 day Paraeducator III position number 9360 to be established in the Special Education Department. This position will be established to provide additional support.

Decrease

a five hour and forty five minute 194 day Campus Assistant position number 3058 to be decreased to five hours at Haydock School. This position will be decreased due to lack of funds.

Abolish

a two hour 194 day Campus Assistant position number 8549 to be abolished in the Neighborhoods For Learning department. This position will be abolished due to lack of funds.

a two hour 194 day Campus Assistant position number 8550 to be abolished in the Neighborhoods For Learning department. This position will be abolished due to lack of funds.

a two hour 194 day Campus Assistant position number 8551 to be abolished in the Neighborhoods For Learning department. This position will be abolished due to lack of funds.

a four hour and thirty minute 260 day Custodian position number 2358 to be abolished in the Neighborhoods For Learning department. This position will be abolished due to lack of funds.

a one hour 260 day Custodian position number 2455 to be abolished in the Neighborhoods For Learning department. This position will be abolished due to lack of funds.

a six hour 194 day Family Liason Bilingual position number 2429 to be abolished in the Neighborhoods For Learning department. This position will be abolished due to lack of funds.

a six hour 194 day Family Liason Bilingual position number 2430 to be abolished in the Neighborhoods For Learning department. This position will be abolished due to lack of funds.

a six hour 194 day Family Liason Bilingual position number 2431 to be abolished in the Neighborhoods For Learning department. This position will be abolished due to lack of funds.

a six hour 194 day Family Liason Bilingual position number 2432 to be abolished in the Neighborhoods For Learning department. This position will be abolished due to lack of funds.

a six hour 194 day Family Liason Bilingual position number 2433 to be abolished in the Neighborhoods For Learning department. This position will be abolished due to lack of funds.

a six hour 194 day Family Liason Bilingual position number 6405 to be abolished in the Neighborhoods For Learning department. This position will be abolished due to lack of funds.

a six hour 194 day Family Liason Bilingual position number 7938 to be abolished in the Neighborhoods For Learning department. This position will be abolished due to lack of funds.

a four hour 217 day Office Assistant II position number 2909 to be abolished in the Neighborhoods For Learning department. This position will be abolished due to lack of funds.

a four hour 260 day Office Assistant II position number 7979 to be abolished in the Neighborhoods For Learning department. This position will be abolished due to lack of funds.

a eight hour 260 day Office Assistant III position number 1808 to be abolished in the Neighborhoods For Learning department. This position will be abolished due to lack of funds.

a three hour 197 day Preschool Assistant Bilingual position number 2893 to be abolished in the Neighborhoods For Learning department. This position will be abolished due to lack of funds.

a three hour 197 day Preschool Assistant Bilingual position number 6358 to be abolished in the Neighborhoods For Learning department. This position will be abolished due to lack of funds.

a three hour 197 day Preschool Assistant Bilingual position number 6359 to be abolished in the Neighborhoods For Learning department. This position will be abolished due to lack of funds.

a three hour 197 day Preschool Assistant Bilingual position number 2894 to be abolished in the Neighborhoods For Learning department. This position will be abolished due to lack of funds.

a four hour 197 day Preschool Teacher Bilingual position number 2895 to be abolished in the Neighborhoods For Learning department. This position will be abolished due to lack of funds.

a four hour 197 day Preschool Teacher Bilingual position number 6336 to be abolished in the Neighborhoods For Learning department. This position will be abolished due to lack of funds.

a three hour 197 day Preschool Teacher Bilingual position number 7213 to be abolished in the Neighborhoods For Learning department. This position will be abolished due to lack of funds.

a three hour 197 day Preschool Teacher Bilingual position number 7796 to be abolished in the Neighborhoods For Learning department. This position will be abolished due to lack of funds.

a three hour 197 day Preschool Teacher Bilingual position number 7801 to be abolished in the Neighborhoods For Learning department. This position will be abolished due to lack of funds.

a three hour 197 day Preschool Teacher Bilingual position number 7802 to be abolished in the Neighborhoods For Learning department. This position will be abolished due to lack of funds.

a three hour 197 day Preschool Teacher Bilingual position number 7803 to be abolished in the Neighborhoods For Learning department. This position will be abolished due to lack of funds.

a three hour 197 day Preschool Teacher Bilingual position number 7945 to be abolished in the Neighborhoods For Learning department. This position will be abolished due to lack of funds.

a six hour 197 day Speech Language Pathology Asst position number 7755 to be abolished in the Neighborhoods For Learning department. This position will be abolished due to lack of funds.

a six hour 197 day Speech Language Pathology Asst position number 7756 to be abolished in the Neighborhoods For Learning department. This position will be abolished due to lack of funds.

a eight hour 12 month Accounting Specialist III position number 1810 to be abolished in the Budget & Finance department. This position will be abolished due to lack of work.

a eight hour 12 month Accounting Specialist III position number 846 to be abolished in the Budget & Finance department. This position will be abolished due to lack of work.

a eight hour 12 month Accounting Specialist IV position number 1747 to be abolished in the Budget & Finance department. This position will be abolished due to lack of work.

a five hour and thirty minute 197 day Paraeducator I position number 7820 to be abolished at Lemonwood School. This position will be abolished due to lack of work.

a four hour 197 day Paraeducator I position number 2805 to be abolished at Harrington School. This position will be abolished due to lack of work.

FISCAL IMPACT:

Cost for Campus Assistant - \$22155, General.

Cost for Paraeducator II - \$56887, Special Education Department.

Cost for Paraeducator III - \$11234, Special Education Department.

Savings for Campus Assistant - \$2885, General.

Savings for Accounting Specialist IV - \$84725, General.

Savings for Accounting Specialist III - \$159598, General.

Savings for Paraeducator I - \$44878, Lemonwood School.

Savings for Campus Assistant - \$23082, Neighborhoods For Learning department.

Savings for Custodian - \$35741, Neighborhoods For Learning department.

Savings for Office Assistant II - \$47711, Neighborhoods For Learning department.

Savings for Preschool Assistant Bilingual - \$57308, Neighborhoods For Learning department.

Savings for Office Assistant III - \$73755, Neighborhoods For Learning department.

Savings for Speech Language Pathology Asst - \$125150, Neighborhoods For Learning department.

Savings for Preschool Teacher Bilingual - \$188150, Neighborhoods For Learning department.

Savings for Family Liason Bilingual - \$376537, Neighborhoods For Learning department.

RECOMMENDATION:

It is the recommendation of the Director of Classified Human Resources that the Board of Trustees approve the establishment, decrease and abolishment of the positions as presented.

ADDITIONAL MATERIAL:

None

OSD BOARD AGENDA ITEM

Name of Contributor: **Dr. Jesus Vaca/Shristie Nair-Villano**

Date of Meeting: **April 3, 2019**

- A. Preliminary _____
Study Session _____
Report _____
- B. Hearing: _____
- C. Consent Agenda X
Agreement Category:
 _____ Academic
 _____ Enrichment
 _____ Special Education
 _____ Support Services
 _____ Personnel
 _____ Legal
 _____ Facilities
- D. Action Items _____
- E. Approval of Minutes _____
- F. Board Policies 1st Reading _____ 2nd Reading _____

Personnel Actions (Vaca/Nair-Villano)

The attached are recommended Personnel Actions presented to the Board of Trustees for consideration. The salary placement for the individuals employed will be in accordance with the salary regulations of the District. Personnel Actions include: new hires, transfers, pay changes, layoffs, recall from layoffs, resignations, retirements, authorizations, and leaves of absence.

FISCAL IMPACT:

N/A

RECOMMENDATION:

It is the recommendation of the Assistant Superintendent, Human Resources & Support Services and the Director, Classified Human Resources, that the Board of Trustees approve the Personnel Actions, as presented.

ADDITIONAL MATERIAL:

- Classified Personnel Actions (two pages)
- Certificated Personnel Actions (one page)

New Hire

Melendes, Michelle	Paraeducator I Position # 7173 Elm 4.10 hrs/ 183 days	3/18/2019
Van Someren, David	Electrician Postion # 9223 Facilities 8 hrs/ 246 days	3/25/2019
Garcia, Lizette	Paraeducator I Postion # 7177 Kamala 4.833 hrs/ 183 days	2/25/2019
Ayala, Rocio	Child Nutrition Worker Position #2222 Frank 5 hrs/ 185 days	3/11/2019
Barajas, Jessica	Office Assistant II (B) Position #1818 Ramona 6 hrs/ 203 days	3/11/2019
Chiquito, Guadalupe	Payroll Technician Position #9177 Budget & Finance 8 hrs/ 246 days	3/25/2019
Espino, Cecilia A	Child Nutrition Worker Position #2425 5.0 hrs/ 185 days	3/11/2019
Reppert, Amanda	Child Nutrition Worker Position #2616 5.5 hrs./ 185 days	3/18/2019
Robles, Lisette V	Outreach Specialist (Bil) Position #2200 Kamala 8 hrs./ 180 days	2/27/2019
Sanchez Hernandez, Graciela	Child Nutrition Worker Position #2221 Frank 5 hrs./185 days	3/11/2019
Wing, Carolyn	Sr. HR Analyst Position #6298 HR Classified 8 hrs./246 days	3/19/2019
Ybarra, Patrice	Child Nutrition Worker Position # 1703 McKinna 5 hrs./ 185 days	3/11/2019

Limited Term

Nolasco, Fernanda	AVID Tutor	3/6/2019
Davis, James E	Campus Assistant (substitute)	1/24/2019
Gil, Gustavo	Child Nutrition Worker (substitute)	3/11/2019
Fregoso, Alejandro	Clerical (substitute)	3/1/2019
Magana, Maria	Health Care Technician (substitute)	3/8/2019
Melendez, Jasmine	Paraeducator (substitute)	3/7/2019
Segura, Siomara	Paraeducator (substitute)	2/1/2019

Promotion

Jindal, Shweta	Payroll Technician Position # 9175 Budget & Finance 8 hrs/ 246 days Account Tech III Position #846 Budget & Finance 8 hrs/ 246 days	2/19/2019
Marquez, Juana	Sr. Payroll Technician Position #9178 Budget & Finance 8 hrs/ 246 days Acct. Spec. IV Position # 1747 Budget & Finance 8 hrs/ 246 days	2/19/2019

Transfer

Duarte, Angela	Admin. Asst. Facilities Position #9002 Facilities 8.0 hrs./246 days	4/1/2019
	Admin. Asst. Ed. Services Position #560 Educational Services 8.0 hrs./246 days	
Navarro, Evangelina	Campus Assistant Position #3014 Marina West 5.5 hrs/ 180 days	3/18/2019
	Campus Assistant Position #3015 Marina West 5.0 hrs/ 180 days	
Perez-Gutierrez, Martiza	Outreach Specialist (B) Position #2688 Marshall 8 hrs/180 days	3/25/2019
	Outreach Specialist (B) Position #1738 Elm 8 hrs/180 days	
Ramirez, Marlene	Campus Assistant Position #3013 Marina West 5.5 hrs/ 180 days	3/18/2019
	Campus Assistant Position #3016 Marina West 5.0 hrs/ 180 days	
Cervantes, Rosa G	Campus Assistant Position #3015 Marina West 5.5 hrs/ 180 days	3/18/2019
	Campus Assistant Position #3013 Marina West 5.0 hrs/ 180 days	

Leave of Absences - Return

Velasquez, Rosario Y	Child Nutrition Worker, Position #1287 Rose Avenue 5 hrs/199 days	3/18/2019
----------------------	--	-----------

Resignation

Escobar Rivas, Yuriana	Paraeducator I Position # 9218 Kamala 5.75 hrs/ 183 days	3/19/2019
Aguila, Eva M	Office Assistant II (B) Position #361 Driffill 8 hrs/ 203 days	2/19/2019
Montesinos, Melissa	Campus Assistant Position #6347 Brekke 3 hrs./ 180 days	3/22/2019

Termination

8241	Campus Assistant Position #3042 Sierra Linda 4.5 hrs/ 180 days	12/17/2018
8952	Campus Assistant Position #6515 Rose Ave. 4.5 hrs/180 days	1/14/2019

CERTIFICATED PERSONNEL ACTIONS

Listed below are recommended Certificated Personnel Actions presented to the Board of Trustees for consideration. The salaries for the individuals employed will be determined, in accordance with the salary regulations of the District.

New Hires

Alfaro, Coraima	Teacher DLI, Soria	03/14/2019
Kirk, Maria	Teacher RSP, Brekke	03/20/2019
Desales, Grace	Substitute Teacher	2018/2019 School Year
Somers, Tom	Substitute Teacher	2018/2019 School Year

Resignations

Dudley, Maggie	Math Teacher, Curren	June 30, 2019
Saracino, Alicia	Teacher, Fremont	June 30, 2019

Retirement

Mallen, Cathy	Teacher, Rose Ave	June 30, 2019
Mickelsen, Mary	Teacher, Rose Ave	June 30, 2019
Sanez, Victoria	Teacher, McAuliffe	June 30, 2019
Yarborough, Holly	Teacher, McAuliffe	June 30, 2019

BOARD AGENDA ITEM

Name of Contributor: Janet Penanhoat

Date of Meeting: 4/3/19

- STUDY SESSION** _____
- CLOSED SESSION** _____
- SECTION A-I: PRELIMINARY** _____
- SECTION A-II: REPORTS** _____
- SECTION B: HEARINGS** _____
- SECTION C: CONSENT AGENDA** _____

- Agreement Category:
- _____ Academic
 - _____ Enrichment
 - _____ Special Education
 - _____ Support Services
 - _____ Personnel
 - _____ Legal
 - _____ Facilities

SECTION D: ACTION _____ **X**

SECTION F: BOARD POLICIES 1st Reading _____ 2nd Reading _____

Ratification of Change Order No. 018 to Construction Services Agreement #15-198 with Swinerton Builders to Adjust Costs for the Lemonwood K-8 School Reconstruction Project (Penanhoat/Fateh/CFW)

The Oxnard School District (“District”) Board of Trustees (“Board”) Facilities Implementation Plan first adopted in January 2013, calls for the reconstruction of the Lemonwood K-8 School (“Project”). The Project includes the construction of new school facilities at the existing Lemonwood school site. The new facilities will provide for a complete K-8 educational program and will consist of a new combined administration and library building, a new multi-purpose room/gymnasium, a 2-story classroom building, kindergarten classroom building and playfields, hardscape and green space to service the new school.

Change Order No. 018 provides for the Board’s consideration and ratification of eighteen (18) change order proposals with the following scope of work:

- PCI No. 0422R1- Provide Structural supports and wall to accept work surface in Administration Building
- PCI No. 0423R1- RFI 0375 Added walls and Plastic Laminate Surfaces at Front Lobby Reception Area
- PCI No. 0426- Install New Frontier Communication Pull Box
- PCI No. 0433- Add Bumpers and Panel Stops to Kindergarten Building
- PCI No. 0446R2- Relocate Chain-Link Fence on Carnegie Court
- PCI No. 0447- Bulletin 58 Saw cut and Remove Concrete for Chain Link revisions
- PCI No. 0451R1- Dedication & Memorial Plaques monument bases
- PCI No 0455- Remove Phase1 access Walkway
- PCI No. 0456- Remove Existing Parkway Trees on San Mateo Place
- PCI No. 0458- RFI #0390 EWH-2 for Buildings 3&4
- PCI No. 0460- CCD 29 Marquee mounting revisions
- PCI No 0461- RFI 374 add signage lighting fixture at administration building
- PCI No 0462- Added Electrical to ECDC HVAC BS Controller
- PCI No. 0464- Remove and Replace City sidewalk on San Mateo place
- PCI No. 0467- RFI 0392 Revise Concrete curb around new playground area north of Kindergarten Building.
- PCI No. 0471- Add Axiom Ceiling Soffit at Media Center Entry
- PCI No. 0473- Delay cost to Underground utility contractor
- PCI No. 0478- Labor cost adjustment- Abdellatif Enterprises

FISCAL IMPACT

One Hundred Nine Thousand Twenty-Five Dollars and Seventy-Seven Cents (\$109,025.77) to be charged to the Master Construct and Implementation Funds. The Board's ratification of this increase to the overall project budget constitutes approval of the allocation of \$109,025.77 from the Program Reserve of the Master Construct & Implementation Program, which will be reflected in the next Semi-Annual Update to the Master Construct and Implementation Program Report.

RECOMMENDATION

It is the recommendation of the Assistant Superintendent, Business & Fiscal Services, and the Director of Facilities, in conjunction with Caldwell Flores Winters, Inc., that the Board of Trustees ratify Change Order No. 018 to Construction Services Agreement #15-198 with Swinerton Builders to provide Construction Services related to the Lemonwood K-8 School Reconstruction Project.

ADDITIONAL MATERIAL

Attached:

- Change Order #018, Swinerton Builders (3 Pages)
- PCI No. 0422R1 (14 Pages)
- PCI No. 0423R1 (7 Pages)
- PCI No. 0426 (5 Pages)
- PCI No. 0433 (3 Pages)
- PCI No. 0446R2 (5 Pages)
- PCI No. 0447 (4 Pages)
- PCI No. 0451R1 (3 Pages)
- PCI No 0455 (4 Pages)
- PCI No. 0456 (3 Pages)
- PCI No. 0458 (7 Pages)
- PCI No. 0460 (3 Pages)
- PCI No 0461 (10 Pages)
- PCI No 0462 (6 Pages)
- PCI No. 0464 (4 Pages)
- PCI No. 0467 (6 Pages)
- PCI No. 0471 (4 Pages)
- PCI No. 0473 (7 Pages)
- PCI No. 0478 (12 Pages)
- Construction Services Agreement #15-198, Swinerton Builders (19 Pages)



CHANGE ORDER

Date: 04.03.2019

CHANGE ORDER NO. 018

PROJECT: LEMONWOOD K-8 RECONSTRUCTION PROJECT
O.S.D. BID No. N/A
O.S.D. Agreement No. 15-198

OWNER: Oxnard School District
1051 South A Street
Oxnard, CA. 93030

ARCHITECT SVA Architects, Inc.
3 MacArthur Place, Ste. 850
Santa Ana, CA 92707

CONTRACTOR:
Swinerton Builders
865 S. Figueroa St.,
Los Angeles, CA 90017
Attn: Michael Darquea

Architects Proj. No.: 2013-40121
D.S.A. File No.: 56-22
D.S.A. App. No.: 03-116026

CONFORMANCE WITH CONTRACT DOCUMENTS, PROJECT MANUAL, DRAWINGS AND SPECIFICATION. All Change Order work shall be in strict conformance with the Contract Documents, Project Manual, Drawings, and Specifications as they pertain to work of a similar nature.

ORIGINAL CONTRACT SUM.....	\$ 29,575,897.91
NET CHANGE - ALL PREVIOUS CHANGE ORDERS (001-017)	\$ 3,869,006.05
ADJUSTED CONTRACT SUM.....	\$ 33,444,903.96
NET CHANGE -	\$ 109,025.77
Total Change Orders to Date: (001-018)	\$ 3,978,031.82
ADJUSTED CONTRACT SUM THROUGH CHANGE ORDER NO.: 017.....	\$ 33,553,929.70

Commencement Date:May 23, 2016
Original Completion Date:July 23, 2018
Original Contract Time:791 Calendar Days
Time Extension for all Previous Change Orders:157 Calendar Days
Time Extension for this Change Order:39 Calendar Days
Adjusted Completion Date:March 30, 2019

Percentage(13.45%)

Item	Description	Unforeseen Condition (UFO)	Additional Scope (AS)	Design Clarification (DC)	Code Requirement
1.	PCI No. 0422R1- Provide structural supports and wall to accept work surface in Administration Building			\$5,609.00	
2.	PCI No. 0423R1- RFI 0375 Added walls and Plastic Laminate surfaces at front lobby Reception area		\$10,769.83		
3.	PCI No. 0426 Install New Frontier Communication pull box	\$ 4,323.39			
4.	PCI No. 0433- Add Bumpers and panel stops to kindergarten building		\$2,726.65		
5.	PCI No. 0446R2- Relocate Chain-link Fence on Carnegie Court		\$17,288.72		
6.	PCI No. 0447- Bulletin 58 Saw cut and remove concrete for chain link revisions		\$3,087.55		
7.	PCI No. 0451R1- Dedication & Memorial Plaques monument bases		\$ 10,687.40		
8.	PCI No. 0455- Remove Phase 1 access walkway			\$ 6,836.26	
9.	PCI No. 0456- Remove Existing parkway trees on San Mateo Place				\$ 3,755.16
10.	PCI No. 0458- RFI #390 EWH-2 for Buildings 3 & 4			\$ 5,104.29	
11.	PCI No. 0460- CCD 29 Marquee mounting revisions		\$ 16,932.52		
12.	PCI No. 0461- RFI 374 add signage lighting fixture at administration building			\$ 1,541.11	
13.	PCI No. 0462- Added electrical to ECDC HVAC BS Controller		\$ 771.10		
14.	PCI No. 0464- Remove and replaced city sidewalk on San Mateo place				\$ 7,243.35
15.	PCI No. 0467- RFI 0392 Revise Concrete curb around new playground area north of Kindergarten Building			\$ 5,267.89	
16.	PCI No. 0471- Add Axiom ceiling soffit at media center entry			\$ 1,090.66	
17.	PCI No. 0473- underground utility	\$ 2,338.38			
18.	PCI No. 0478- Labor cost adjustment- Abdellatif Enterprises	\$ 3,652.51			
	Totals	\$10,314.28	\$62,263.77	\$25,449.21	\$10,998.51

Total Change Order No. 018 \$ 109,025.77

APPROVAL (REQUIRED):

ARCHITECT: _____

DATE: _____

CONTRACTOR: _____

DATE: _____

RECOMMENDED FOR APPROVAL:

OSD DSA INSPECTOR: _____

DATE: _____

ASST. SUPERINTENDENT, BUSINESS & FISCAL SERVICES

DATE: _____

APPROVAL (REQUIRED):

BOARD APPROVAL

DATE: _____

ASST. SUPT./PURCHASING DIRECTOR: _____

DATE: _____

DSA APPROVAL

DATE: _____



SWINERTON

February 21, 2019

Oxnard School District
1051 South A Street
Oxnard, CA, 93030

Attn: Mario Mera

Subject: Swinerton Builders Job 16055106 - Lemonwood K-8 School LLB
PCI No. 0422r1 RFI 375 Added structural supports for workstation pony wall

Dear Mr. Mera,

We request a Change Order to our contract for the following:

Furnish and install structural supports and wall to accept work surface in the Work/Copy area in the Administration Building. Contract documents do not indicate a wall in this area to support the scheduled brackets.

Phase	Category	Description	Subcontractor	Quote
015300	71130	Install structural supports	SWINERTON-MATERIAL	157.94
015300	71111	Install structural wall supports	SWINERTON-LABOR	1,280.00
051200	71140	Provide structural supports and wall to accept work surface in Administration Building RFI 0375	BECK STEEL, INC.	2,428.00
092900	71140	Hang and tape wall	RUTHERFORD CO., INC.	1,290.00
			Subtotal	5,155.94
007480	71160	Subguard	1.15%	59.29
007410	71160	Builders Risk	0.6%	31.29
007420	71160	General Insurance	1.15%	59.98
007510	71160	P&P Bond	1%	37.18
991000	79999	Change Order Fee	5%	265.32
			Markup Subtotal	453.06
			PCI Total	5,609.00

TOTAL AMOUNT OF THIS CHANGE ORDER REQUEST: **5,609.00.**

Please NOTE:

- » The incorporation of this revision in to the contractual scope of work may have an impact on our schedule, which is yet to be finalized. Once determined, the job schedule will be adjusted accordingly to



SWINERTON

show the effect of this revision on the final project completion date..

- » The terms (cost and schedule impact) of this change order request are subject to review and a requote if not accepted within days of its issuance.
- » This request does not include additional cost or delay due to late approval.

X We **HAVE** proceeded with this revised work per your instructions. Please issue a change order.

Upon acceptance of this change order request, a formal change order will be issued. Acceptance also acknowledges that Swinerton Builders has proceeded with the above change in scope.

If you have any questions or comments pertaining to this matter, please contact the undersigned.

Sincerely,
Swinerton Builders

[Handwritten Signature]
2/21/2019

Date: _____

Quotation accepted by:
Oxnard School District

By: _____

Date: _____



More saving.
More doing.

STORE MGR RIAN CARLETON 805-983-0653
RIAN_CARLETON@HOMEDEPOT.COM

1040 00003 92662 01/18/19 08:40 AM
CASHIER JOANN

026703055550 HOMER BUCKET <A> 3.25
5 GAL BUCKET-HOMER LOGO (ORANGE)
707392361367 NO. 8 SCREW <A>
1-1/4IN NO. 8 STRONG DRIVE SCREW 38.72
4@9.68
044315046001 FRAME ANCHOR <A>
3INX5IN ANGLE FRAMING ANCHOR 21.60
60@0.36
073291332006 4X6-8 GDF <A>
3.5IN X 5.5IN - 8FT #2BTR PRIME DF 26.94
2@13.47
0000-999-735 CA LBR FEE <A,U>
CA LUMBER FEE 0.26N
2@0.13

SUBTOTAL 90.77
SALES TAX 7.01
TOTAL \$97.78
XXXXXXXXXXXX5376 HOME DEPOT 97.78
AUTH CODE 018949/5031377 TA

SWINERTON BUILDERS SACRAMEN
TRAIL MARK A

<U> - NON-DISCOUNTABLE ITEM

PRO XTRA MEMBER STATEMENT

PRO XTRA ###-###-4825 SUMMARY
THIS RECEIPT PO/JOB NAME: 16055106



Buy well

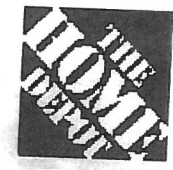

More saving.
More doing.

STORE MGR RIAN CARLETON 805-983-0653
RIAN_CARLETON@HOMEDEPOT.COM

1040 00002 07555 01/08/19 08:43 AM
CASHIER MARIA

044315046001 FRAME ANCHOR <A>
3INX5IN ANGLE FRAMING ANCHOR 30@0.35
000346493269 HCF02067 <A> 10.50
BOSCH XTREME 3/8X18 SDS HAMMER BIT 25.97
707392361367 NO. 8 SCREW <A>
1-1/4IN NO. 8 STRONG DRIVE SCREW
2@9.68

SUBTOTAL 19.36
SALES TAX 55.83
TOTAL \$60.16
XXXXXXXXXXXX5376 HOME DEPOT 60.16
AUTH CODE 008850/5024012 TA

SWINERTON BUILDERS SACRAMEN
TRAIL MARK A

PRO XTRA MEMBER STATEMENT

PRO XTRA ###-###-4825 SUMMARY
THIS RECEIPT PO/JOB NAME: 16055106



December 6, 2018

Swinerton
865 S. Figueroa Street, Suite 3000
Los Angeles, Ca 90017
(805) 832-4993

Attention: Nalani Scanlon

Reference: Lemonwood K-8 Reconstruction
Job # 1624 BCP# 22

Nalani,
Please find below our estimated cost associated with scope changes as a result of RFI #375; detail fabricate and deliver new low wall supports with anchors.

The scope of the change is as follows:

Detailing	\$130
Engineering	\$0
Material	\$0
Joists	\$0
Deck	\$0
Other Buyouts simpson anchors	\$111
Fab Farmout fabco invoice 165766	\$1,542
Freight	\$200
Tax on Material	\$128
Subtotal:	<u>\$2,111</u>
15% Markup:	\$317
Total Field Cost per Attached:	\$0
5% OH&P	\$0
Total Change Order Request:	<u>\$2,428</u>

Requested Change in Subcontract Time due to this change (Work Days) 0

The requested extension to the Subcontract Schedule reflects ___ additional days for fabrication and ___ for installation.

Please note that the material pricing portion will only be valid for (15) days from the initial quotation on all Beck Change Proposals (BCPs). All quotations after this duration will be subject to review and adjusted pricing based on current market conditions.

We await written acceptance of pricing and notice to proceed. Do not hesitate to call with any questions you might have regarding this proposal.

Best Regards,

Colin Peckham/ cf
Project Manager
Beck Steel, Inc.
(909) 376-9119

Purchase Order

Beck Steel, Inc.
401 N. Loop 289
Lubbock, TX 79403
(806) 765-9869

P.O. Number: 0060267 - 1624
Order Date: 11/16/2018

Vendor Number: 11-0010087

Vendor:
Bristol Machine Co.
5536 Ontario Mills PKWY
Ontario, CA 91764

Ship To:
Swinerton Jobsite Trailer
Att.Nalani 213-334-1807
2200 Carnegie Court.
Oxnard, CA 93033

Confirm To:
MARIO 800-798-9321

Required Date	Ship VIA	F.O.B.	Terms				
11/21/2018	BEST WAY	PLUS FRT.	Net 30				
Item Code	Unit	Ordered	Received	Backordered	Unit Cost	Amount	
* SIMPSON SET XP EPOXY	EACH	2.00	0.00	0.00	38.0000	76.00	
* 1/2X4 1/2" THREADED RODS	EACH	25.00	0.00	0.00	1.3000	32.50	
* 1/2" NUTS	EACH	25.00	0.00	0.00	0.0500	1.25	
* 1/2"WASHERS	EACH	25.00	0.00	0.00	0.0400	1.00	
* PLUS FRT.	LOT	1.00	0.00	0.00	0.0000	0.00	

LABEL JOB#1624 RFI 375
SHIP TO JOBSITE ADDRESS ABOVE AS SOON AS POSSIBLE

Approved By: B.N.

Net Order: 110.75
Sales Tax: 0.00
Freight: 0.00
Order Total: 110.75

TERMS AND CONDITIONS OF PURCHASE ORDER

1. **ACCEPTANCE.** Without releasing Seller of its obligations promptly to acknowledge receipt hereof, this Purchase Order (the "Order") becomes a binding contract on the terms set forth herein when it is accepted by Seller either by acknowledgement or by commencement hereunder. No revisions to this Order shall be valid unless accepted in writing and signed by an authorized representative of Buyer. No qualification, condition or exception stated by Seller in accepting or acknowledging this Order shall be binding upon Buyer unless expressly accepted in writing by Buyer.
2. **CHANGES.** Buyer shall have the right at any time before the completion of this Order to make changes in quantities, in the drawings or specifications, in delivery schedules, and methods of shipment. If such changes cause an increase or decrease in Seller's costs or time of performance, an equitable adjustment of this Order shall be made by mutual written agreement. Unless there is agreement to an equitable adjustment at the time the change is directed, Seller must make claim in writing to Buyer no later than three (3) days after the change is directed. Seller's entitlement to any equitable adjustment of price or time of performance shall be limited to whatever equitable adjustment, if any, Buyer can obtain from its Customer on Seller's behalf.
3. **BUYER'S CONTRACT WITH CUSTOMER.** The work and material provided under this Order are for the performance of Buyer's contract with Buyer's Customer, a copy of which is available for examination and copying upon Seller's request. All applicable provisions of Buyer's contract with Buyer's Customer, including but not limited to the risk of loss provisions therein, are incorporated in this Order. Seller is obligated to Buyer under this Order to the same extent as Buyer is obligated to Buyer's Customer under Buyer's contract with Buyer's Customers and its specifications, drawings and other documents which concern the work to be done and/or material to be supplied under this Order.
4. **PAYMENT.** Seller acknowledges and agrees that Buyer shall pay Seller out of funds to be received from Buyer's Customer and that Buyer's obligation to make payment to Seller under this Purchase Order is expressly conditioned upon Buyer having received payment from Buyer's Customer for Seller's material and or services. Buyer's receipt of payment from its Customer for Seller's materials and/or services shall be a condition precedent to Buyer's obligation to make any payment to Seller.
5. **WARRANTIES.** All material and workmanship provided hereunder shall conform to applicable specifications, drawings and samples, shall be free from defects, and shall be fit for their intended use. These provisions are in addition to all other warranties implied by law or in Buyer's contract with its Customer, which is incorporated herein by reference.
6. **INDEMNITY.** Seller agrees to defend, indemnify and save harmless Buyer and Buyer's Customer from and against any and all demands, claims, lawsuits, losses, liabilities and expenses including reasonable attorneys' fees, arising out of or relating to the performance of this Order, which are caused or alleged to be caused in whole or in part by any act or omission of Seller, regardless of whether it is caused in part by the negligence of Buyer or Buyer's Customer. Such obligation to defend, indemnify and hold harmless shall include without limitations: (a) claims of infringement or violation of any copyrights, patent rights or similar rights; (b) claims of injuries and damage to property and persons, including death, (c) claims on account of actions or omission by Seller, or any of Seller's officers, agents, employees or servants; (d) claims due to defects in material, whether actual or alleged; or (e) attachments, garnishments, executions and liens by creditors of Seller or others claiming to have acquired rights from or against Seller.
7. **TIME OF PERFORMANCE - DEFAULT.** Time is of the essence in Seller's performance of this Order. Seller is fully aware of the consequence, injury and damage to Buyer which can arise from any default or breach of Seller's delivery obligations under this Order. Seller shall be liable to Buyer for any damages suffered by Buyer as a result of Seller's failure to timely perform its obligations under this Order.
8. **TERMINATION FOR DEFAULT.** Buyer has the right to cancel this Order or any part of this Order without penalty if delivery is not made on time on the date(s) specified. Seller must notify Buyer if delivery date cannot be met. Penalties or additional costs incurred by Buyer because of Seller's delay or nonperformance shall be charges to the Seller. If the contract between Buyer and Buyer's Customer contains any provision for termination for convenience by Buyer's Customer, this Order may be terminated in whole or in part under the same terms and conditions as provided in said contract for like termination by Buyer's Customer.
9. **SUSPENSION OF SHIPMENT.** Seller shall, upon Buyer's request, suspend shipment of materials and/or performance of services hereunder for such period as Buyer may request. If shipment is suspended, then Seller shall be entitled to an equitable adjustment in the time of performance only as provided for in paragraph 2 above as Seller's sole and exclusive compensation and remedy for such suspension.
10. **EQUAL OPPORTUNITY:** Seller will comply with all provisions of Executive Order No. 11246, as amended or superseded, the rules, regulations and relevant orders of the Secretary of Labor and other rules and regulations as provided by law. Seller shall furnish all information and reports as may be required and will permit access to his books, records and accounts by the Buyer, government agencies and Secretary of Labor for the purpose of investigating compliance with such rules, regulations and relevant orders.
11. **JURISDICTION:** This Purchase Order shall be governed by and construed in accordance with the law of the State of Texas.
12. **DISPUTES:** Any disputed arising under or relating to this Order shall be subject to arbitration under the Construction Industry Arbitration Rules of the AAA, with venue in Lubbock, Texas. The prevailing party shall be entitled to costs and reasonable attorney's fees. If a dispute between Buyer and Seller involves a claim or dispute against Buyer's Customer, then Seller shall be limited to the disputes procedures provided for in Buyer's agreement with its Customer and Seller shall be bound by the outcome of such dispute procedures involving Buyer's Customer.



Steel Fabrication, Inc.
L. A. City Licensed Fabricator

INVOICE 165766-00

Mailing: P.O. Box 8636, Alta Loma, CA 91701
Plant: 14688 San Bernardino Ave., Fontana, CA 92335
(909) 350-1535 • FAX # (909) 350-1871
E-mail: fabco@fabcosteel.com
www.Fabcosteel.com

Sold To:
Colin
BECK STEEL INC.
401 N. Loop 289
Lubbock
TX, 79403

Ship To: Nalani
SWINERTON JOBSITE TRAILER
2200 Carnegie Ct
Oxnard, CA 93033

Phone: 213 334-1807 806 765-8050

Order No. 0060264-1624	Date 11/30/2018	Required Date 11/28/2018	Date Shipped 11/29/2018	Shipped Via FABCO DELIVER	Terms NET30
---------------------------	--------------------	-----------------------------	----------------------------	------------------------------	----------------

Qty	B/O	Description	Unit Price	Total
6	0	4" X 2" X 3/16" TUBE STEEL WELDMENTS 2'-8 1/2" LONG PRIMED		
6	0	4" X 2" X 3/16" TUBE STEEL WELDMENTS 2'-10 1/2" LONG PRIMED		
0	0			
0	0	LABOR CHARGE	1,075.36	1,075.36
0	0	MATERIAL CHARGE	466.51	466.51
CERTS REQUIRED ***RED PRIMER***				
Subtotal:				1,541.87

Customer Materials - No
Fabco Materials - Yes

Sales Tax (Resale): 0.00
Shipping: 0.00
Invoice Total: 1,541.87
Payments: 0.00
Balance Due: \$1,541.87

NOT RESPONSIBLE FOR DAMAGES TO ANY VEHICLES WHILE LOADING OR UNLOADING MATERIAL.

GRIZZ

Fabco

Steel Fabrication, Inc.

L. A. City Licensed Fabricator

PACKING LIST 165766-00

Mailing: P.O. Box 8636, Alta Loma, CA 91701
Plant: 14688 San Bernardino Ave., Fontana, CA 92335
(909) 350-1535 • FAX # (909) 350-1871
E-mail: fabco@fabcosteel.com
www.Fabcosteel.com

Sold To:
Colin
BECK STEEL INC.
401 N. Loop 289
Lubbock, TX 79403

Ship To: Nalani
SWINERTON JOBSITE TRAILER
2200 Carnegie Ct
Oxnard, CA 93033

Phone: 213 334-1807 806 765-8050

Order No.	Date	Required Date	Date Shipped	Shipped Via	Terms
0060264-1624		11/28/2018	11/27/2018	FABCO DELIVER	NET30

Qty	B/O	Description		
6	0	4" X 2" X 3/16" TUBE STEEL WELDMENTS 2'-8 1/2" LONG PRIMED		
6	0	4" X 2" X 3/16" TUBE STEEL WELDMENTS 2'-10 1/2" LONG PRIMED		
CERTS REQUIRED ***RED PRIMER***				

Customer Materials - No
Fabco Materials - Yes

DATE 11-29-18 PRINT NAME MARK TRAIL

Page 1

RECEIVED BY Mark Trail

NOT RESPONSIBLE FOR DAMAGES TO ANY VEHICLES WHILE LOADING OR UNLOADING MATERIAL.

A service charge of 1 1/2% per month 18% annually will be charged on past due accounts.
All returned material subject to 25% restocking fee.

PAY IN U.S. DOLLARS ONLY.

Thank you

165766

TEST CERTIFICATE



Certificate No: 422590

Created On: 08/10/2018

Document source: NZ Steel

Customer: Genesis Metals Customer Order No: 111609 End User Reference: 18699	Supplier: New Zealand Steel Limited A BlueScope Company 131 Mission Bush Road, Glenbrook, South Auckland Postak Private Bag 92121, Auckland 1142, New Zealand Telephone: (09) 375 8111 Auckland Fax: (09) 375 8959 Sales Order No : 1295243 Printed On : 08/10/2018
	New Zealand Steel hereby certifies that the Material described herein has been tested and inspected with satisfactory results in accordance with the requirements of the named specification. Rob Behlman (on behalf of New Zealand Steel) Rolling and finishing Technical Manager
Specification: ASTMA36(2012) Product : 0.37" x 48" x Coil HOT ROLLED COIL	Inspection: Supplier Certification: Supplier

ITEMS COVERED BY THIS CERTIFICATE

Pack No	Heat No	Ordered Dimensions	Tested Unit
HHG1091100, HHG1091200	961903	0.37" x 48" x Coil	HHG1091100
HHG1091400	961443	0.37" x 48" x Coil	HHG1091400
HHG1091500	962105	0.37" x 48" x Coil	HHG1091500
HHG1091600	961902	0.37" x 48" x Coil	HHG1091600

CHEMICAL ANALYSIS

Percentage of element by mass

(L=Cast, P=Product, S=Soluble, -T=Total, CF=Chemical Formula, n=Min, x=Max)

Heat No	L/P	x100										x1000			B	N2	CP
		C	SI	Mn	P	S	CU	NI	Cr	Mo	V	Nb	TI	Al-T			
961443	L	16	1	59	13	16	13	15	15	1	5	TR	TR	43	TR	60	26
961902	L	18	1	64	18	15	11	13	23	1	10	3	2	66	TR	70	28
961903	L	18	1	63	20	15	11	13	24	1	10	3	2	45	TR	70	28
962105	L	18	1	64	24	17	11	15	26	1	11	4	1	50	TR	60	29

TR composition: Si (TR) < 0.01%, Mn/Nb/Ti (TR) < 0.001%, B (TR) < 0.0001%

CF=C=Mr/6

MECHANICAL TESTING

Tensile

Tested Unit	Heat No	ReL psi	Rm psi	Lo	ELONG %
HHG1091100	961903	51200	69600	F	24
HHG1091400	961443	49600	69200	F	25
HHG1091500	962105	49600	69200	F	26
HHG1091600	961902	49500	69000	F	22

COMMENTS

Steel produced through the basic oxygen steelmaking process by New Zealand Steel. - Heat analysed from ladle - Results relate to test on a representative sample of the items covered in this test certificate. - This certificate may not be reproduced except in full. - NZ Steel, Chemical Laboratory IANZ Accreditation Number 101, KTP Mr David Sherie. - NZ Steel, Mechanical Laboratory IANZ Accreditation Number 965, Approved Signatory Mr Schalk Bester. NZ Steel Laboratories are accredited by, International Accreditation New Zealand (IANZ), a signatory to the International Laboratory Accreditation Cooperation mutual Recognition Agreement. Test methods for chemical analysis were, ASTM E415 & IIS G1253.

New Zealand Steel operate a quality management system conforming to AS/NZS ISO 9001 as assessed by Telarc SA1 Ltd Registration Number: 82.

MECHANICAL COMMENTS

Test methods for Mechanical analysis were, ASTM A370

Gauge Length Lo(F) = 8"

Lower Yield Stress,

105760

MILL CERTIFICATE

THIS TUBING WAS MANUFACTURED IN THE U.S.A.

Date: 11/12/18



Sales Order No: B32629
 Customer: B & B SURPLUS
 : 1505

Specification: R500B/C-13

Article: 214671

S I Z E	Quantity		Chemical Composition (Units Analysis)										Tensile Test			Heat No. (Date Produced)
	Number of Pieces	Calculated Weight per lb	C	Mn	P	S	Si	Cr	Mo	Ni	U	Yield Strength (psi)	Tensile Strength (psi)	Elongation (%)		
1-1/2 SQ X .188 X HR 20*	25	2.100	6	71	12	3	12	0	0	0	0	63000	63000	27	27 / 270879 10/22/18	
1/2 188ST 20	36	5.590	6	77	13	5	14	0	0	0	0	53000	57000	27	28 / 270879 10/22/18	
3/4 188RT 20	46	6.868	20	84	8	4	20	3	2	2	0	60000	74000	28	28 / 253374 09/26/18	
1 1/2 188RT 20	15	7.020	6	77	12	4	14	0	0	0	0	63000	69000	28	28 / 253374 10/19/18	

We hereby certify that the material described herein conforms fully to the said specification. Unless noted this tubing does not meet the melted and manufactured specification for MADE IN AMERICA.

SEARING INDUSTRIES, INC.

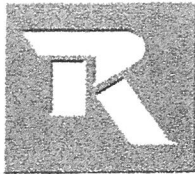

Rutherford Co., Inc.
 2107 Crystal Street
 Los Angeles, CA 90039
 Phone: (323) 666-5284 / Fax: (323) 665-0328
 www.rutherfordco.net

Date:	01/28/19
RCI Job #:	16-075
RCI COR #:	111
GC Tracking #:	

CHANGE ORDER REQUEST

EMAIL: bgray@swinerton.com
 TO: Swinerton Builders
 ATTN.: Bill Gray
 JOB NAME: **LEMONWOOD K-8 SCHOOL:**

DESCRIPTION OF WORK:

OTP #30091: Tape Pony Walls at Admin Building #3.

BREAKDOWN:		HR. RATE	QTY.	UNIT	AMOUNT	COMMENTS
LABOR	Regular-Journeyman	\$78.60	8	HRS	\$ 628.80	
	Regular-Foreman	\$0.00	0	HRS	\$ -	
	Regular-Superintendent	\$0.00	0	HRS	\$ -	
	Safety/QC Manager	\$0.00	0	HRS	\$ -	
	Overtime-Journeyman	\$0.00	0	HRS	\$ -	
	Doubletime-Journeyman	\$0.00	0	HRS	\$ -	
MATERIAL		\$20.00	0	Tax	\$ 21.90	
EQUIPMENT	Scissor Lift	\$0.00	0	Day		
	Dumpster	\$0.00	0	ea.		
		\$0.00	1	Day	\$ -	
SCAFFOLD		\$0.00	0	Day	\$ -	
SUBS/MISC.						
FREIGHT/DELIVERY		\$200.00	0	LS	\$ -	
		\$0.00	0	LS	\$ -	
		\$0.00	0	LS	\$ -	
SUBTOTAL					\$ 650.70	
15.0% OHP MARKUP					\$ 97.61	
COR TOTAL:					\$ 748	

QUALIFICATIONS

- ADDITIONAL TIME MAY BE REQUIRED ON THE PROJECT SCHEDULE FOR THE WORK DESCRIBED ABOVE
- ALL GAS/ELECTRIC EQUIPMENT USED FOR THIS COR WILL BE CHARGED AT A 1-DAY MINIMUM RENTAL

"THIS PROPOSAL IS FOR THE DESCRIBED WORK ONLY. PRICING IS BASED ON THE CURRENT PROJECT STATUS. RUTHERFORD IS ENTITLED TO COMPENSATION FOR ADDITIONAL COSTS IF THE PROJECT STATUS CHANGES BEFORE APPROVAL. FURTHERMORE, THE STATED PRICE DOES NOT INCLUDE ANY AMOUNT FOR COSTS RESULTING FROM IMPACTS, WHETHER THE IMPACTS ARE CAUSED BY SCHEDULING, RESCHEDULING, OUT OF SEQUENCE OPERATIONS, TRADE CONGESTION, OTHER DISRUPTIONS, DELAYS OR ACCELERATION. RUTHERFORD EXPRESSLY RESERVES THE RIGHT TO COLLECT FULL OVERHEAD AND PROFIT FOR ANY OF SUCH IMPACTS."

Submitted By:
Project Manager

Approved By:

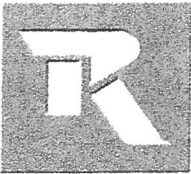

Rutherford Co., Inc.
 2107 Crystal Street
 Los Angeles, CA 90039
 Phone: (323) 666-5284 / Fax: (323) 665-0328
 www.rutherfordco.net

Date:	01/28/19
RCI Job #:	16-075
RCI COR #:	112
GC Tracking #:	

CHANGE ORDER REQUEST

EMAIL: bgray@swinerton.com

TO: Swinerton Builders

ATTN.: Bill Gray

JOB NAME: **LEMONWOOD K-8 SCHOOL:**

DESCRIPTION OF WORK:

OTP #30092: Tape Pony Walls at Admin Building #3.

BREAKDOWN:		HR. RATE	QTY.	UNIT		AMOUNT	COMMENTS
LABOR	Regular-Journeyman	\$78.60	6	HRS	\$	471.60	
	Regular-Foreman	\$0.00	0	HRS	\$	-	
	Regular-Superintendent	\$0.00	0	HRS	\$	-	
	Safety/QC Manager	\$0.00	0	HRS	\$	-	
	Overtime-Journeyman	\$0.00	0	HRS	\$	-	
	Doubletime-Journeyman	\$0.00	0	HRS	\$	-	
MATERIAL		\$0.00	0	Tax			
EQUIPMENT	Scissor Lift	\$0.00	0	Day			
	Dumpster	\$0.00	0	ea.			
		\$0.00	1	Day	\$	-	
SCAFFOLD		\$0.00	0	Day	\$	-	
SUBS/MISC.							
FREIGHT/DELIVERY		\$200.00	0	LS	\$	-	
		\$0.00	0	LS	\$	-	
		\$0.00	0	LS	\$	-	
SUBTOTAL					\$	471.60	
15.0% OHP MARKUP					\$	70.74	
COR TOTAL:					\$	542	

QUALIFICATIONS

- ADDITIONAL TIME MAY BE REQUIRED ON THE PROJECT SCHEDULE FOR THE WORK DESCRIBED ABOVE
- ALL GAS/ELECTRIC EQUIPMENT USED FOR THIS COR WILL BE CHARGED AT A 1-DAY MINIMUM RENTAL

"THIS PROPOSAL IS FOR THE DESCRIBED WORK ONLY. PRICING IS BASED ON THE CURRENT PROJECT STATUS. RUTHERFORD IS ENTITLED TO COMPENSATION FOR ADDITIONAL COSTS IF THE PROJECT STATUS CHANGES BEFORE APPROVAL. FURTHERMORE, THE STATED PRICE DOES NOT INCLUDE ANY AMOUNT FOR COSTS RESULTING FROM IMPACTS, WHETHER THE IMPACTS ARE CAUSED BY SCHEDULING, RESCHEDULING, OUT OF SEQUENCE OPERATIONS, TRADE CONGESTION, OTHER DISRUPTIONS, DELAYS OR ACCELERATION. RUTHERFORD EXPRESSLY RESERVES THE RIGHT TO COLLECT FULL OVERHEAD AND PROFIT FOR ANY OF SUCH IMPACTS."

Submitted By:

Project Manager

Approved By:

AUTHORIZATION FOR EXTRA WORK

PROJECT: LEVIN WORKS JOB NO. 1000
LOCATION: 1000 1000 1000

DESCRIPTION:
AS FOR AND REPAIR & SWINZON
FINISH SEASON
700 PAV WALLS
[REDACTED] 500 BOTTLE WALLS

LABOR & MATERIAL BREAKDOWN

TOTAL MEN		TOTAL	
	6		6

EQUIPMENT RENTAL (1 DAY MAXIMUM ON ALL RENTALS)

TUCKING	SCISSOR LIFTS	FIRE PROOF PUMPS
WELDERS	CEMENT PUMPS	MIXERS
COMPRESSORS	FORKLIFTS	SCAFFOLD
ROLLING UNITS		

WORK ACCEPTED & COMPLETED
WORK ONSITE

AUTHORIZED SIGNER
CONTRACTOR: JIMMY TAN
DATE: 01/11/18
PRINTED NAME: JIMMY TAN

RECORD



SWINERTON

February 21, 2019

Oxnard School District
 1051 South A Street
 Oxnard, CA, 93030

Attn: Mario Mera

Subject: Swinerton Builders Job 16055106 - Lemonwood K-8 School LLB
 PCI No. 0423r1 RFI 0375 Furnish and install front lobby reception wall and counter

Dear Mr. Mera,

We request a Change Order to our contract for the following:

Per contract documents, the front Lobby Reception desk is identified as note 530. Note 530 identifies the Reception desk as O.F.O.I.. Not part of it, but in it's entirety. This is to furnish and install supporting wall, structural supports, solid surface writing surfaces on top of wall, and ADA portion. Also included is the added swing gate.

Phase	Category	Description	Subcontractor	Quote
015300	71150	Per contract documents, the front Lobby Reception desk is identified as note 530. Note 530 identifies the Reception desk as O.F.O.I.. Not part of it, but in it's entirety. This is to furnish and install supporting wall, structural supports, solid surface writing surfaces on top of wall, and ADA portion. Also included is the added swing gate. Swinerton building material	SWINERTON-MATERIAL	358.21
015300	71111	Per contract documents, the front Lobby Reception desk is identified as note 530. Note 530 identifies the Reception desk as O.F.O.I.. Not part of it, but in it's entirety. This is to furnish and install supporting wall, structural supports, solid surface writing surfaces on top of wall, and ADA portion. Also included is the added swing gate. Swinerton labor to lay-out, install structural supports, frame walls, install sub-tops.	SWINERTON-LABOR	3,200.00
064100	71140	Per contract documents, the front Lobby Reception desk is identified as note 530. Note 530 identifies the Reception desk as O.F.O.I.. Not part of it, but in it's entirety. This ROM is to furnish and install supporting wall, structural supports, plastic laminate writing surfaces on top of wall, and ADA portion. Also included is the added swing gate.	STOLO CABINETS, INC.	4,734.00
092900	71140	Hang and tape drywall at front lobby reception wall	RUTHERFORD CO., INC.	1,615.00
			Subtotal	9,907.21
007480	71160	Subguard	1.15%	113.93
007410	71160	Builders Risk	0.6%	60.13



SWINERTON

007420	71160	General Insurance	1.15%	115.24
007510	71160	P&P Bond	1%	63.49
991000	79999	Change Order Fee	5%	509.83
			Markup Subtotal	862.62
			PCI Total	10,769.83

TOTAL AMOUNT OF THIS CHANGE ORDER REQUEST: **10,769.83.**

Please NOTE:

- » The incorporation of this revision in to the contractual scope of work may have an impact on our schedule, which is yet to be finalized. Once determined, the job schedule will be adjusted accordingly to show the effect of this revision on the final project completion date..
- » The terms (cost and schedule impact) of this change order request are subject to review and a requote if not accepted within days of its issuance.
- » This request does not include additional cost or delay due to late approval.

X We **HAVE** proceeded with this revised work per your instructions. Please issue a change order.

Upon acceptance of this change order request, a formal change order will be issued. Acceptance also acknowledges that Swinerton Builders has proceeded with the above change in scope.

If you have any questions or comments pertaining to this matter, please contact the undersigned.

Sincerely,
Swinerton Builders

2/21/2019

Date: _____

Quotation accepted by:
Oxnard School District

By: _____

Date: _____

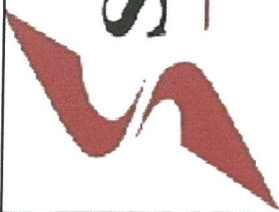

STOLO CABINETS

Since 1953

LEMONWOOD ES		CHANGES PER RFI 375					
COR 07a		1/7/2019					
ITEM	COMMENTS	UOM	ORIG. QTY	NEW QTY	DIFFERENCE	UNIT COST	TOTAL
SOLID SURFACE CTOPS		SQFT	0	14.00	14.00	\$ 90.00	\$ 1,260.00
MDF WALL CAP		LF	0	17.00	17.00	\$ 26.50	\$ 450.50
SWING GATE		EA	0	1.00	1.00	\$ 750.00	\$ 750.00
INSTALLATION		HR	0	12.00	12.00	\$ 69.63	\$ 835.56
CITY OF OXNARD LIC RENEWAL		EA	0	1.00	1.00	\$ 403.00	\$ 403.00
SUB-TOTAL							\$3,699
15% P & O							\$555
TOTAL							\$4,254

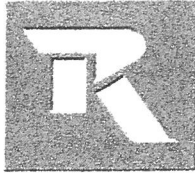

Rutherford Co., Inc.
 2107 Crystal Street
 Los Angeles, CA 90039
 Phone: (323) 666-5284 / Fax: (323) 665-0328
 www.rutherfordco.net

Date:	01/28/19
RCI Job #:	16-075
RCI COR #:	110
GC Tracking #:	

CHANGE ORDER REQUEST

EMAIL: bgray@swinerton.com

TO: Swinerton Builders

ATTN: Bill Gray

JOB NAME: **LEMONWOOD K-8 SCHOOL:**

DESCRIPTION OF WORK:

OTP #30088: Tape at Pony Walls Admin Building #3.

BREAKDOWN:		HR. RATE	QTY.	UNIT	AMOUNT	COMMENTS
LABOR	Regular-Journeyman	\$78.60	8	HRS	\$ 628.80	
	Regular-Foreman	\$0.00	0	HRS	\$ -	
	Regular-Superintendent	\$0.00	0	HRS	\$ -	
	Safety/QC Manager	\$0.00	0	HRS	\$ -	
	Overtime-Journeyman	\$0.00	0	HRS	\$ -	
	Doubletime-Journeyman	\$0.00	0	HRS	\$ -	
MATERIAL		\$40.00	0	Tax	\$ 43.80	
EQUIPMENT	Scissor Lift	\$0.00	0	Day		
	Dumpster	\$0.00	0	ea.		
		\$0.00	1	Day	\$ -	
SCAFFOLD		\$0.00	0	Day	\$ -	
SUBS/MISC.						
FREIGHT/DELIVERY		\$200.00	0	LS	\$ -	
		\$0.00	0	LS	\$ -	
		\$0.00	0	LS	\$ -	
SUBTOTAL					\$ 672.60	
15.0% OHP MARKUP					\$ 100.89	
COR TOTAL:					\$ 773	

QUALIFICATIONS

1. ADDITIONAL TIME MAY BE REQUIRED ON THE PROJECT SCHEDULE FOR THE WORK DESCRIBED ABOVE
2. ALL GAS/ELECTRIC EQUIPMENT USED FOR THIS COR WILL BE CHARGED AT A 1-DAY MINIMUM RENTAL

"THIS PROPOSAL IS FOR THE DESCRIBED WORK ONLY. PRICING IS BASED ON THE CURRENT PROJECT STATUS. RUTHERFORD IS ENTITLED TO COMPENSATION FOR ADDITIONAL COSTS IF THE PROJECT STATUS CHANGES BEFORE APPROVAL. FURTHERMORE, THE STATED PRICE DOES NOT INCLUDE ANY AMOUNT FOR COSTS RESULTING FROM IMPACTS, WHETHER THE IMPACTS ARE CAUSED BY SCHEDULING, RESCHEDULING, OUT OF SEQUENCE OPERATIONS, TRADE CONGESTION, OTHER DISRUPTIONS, DELAYS OR ACCELERATION. RUTHERFORD EXPRESSLY RESERVES THE RIGHT TO COLLECT FULL OVERHEAD AND PROFIT FOR ANY OF SUCH IMPACTS."

Submitted By:

Project Manager

Approved By:

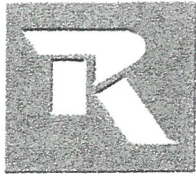

Rutherford Co., Inc.
 2107 Crystal Street
 Los Angeles, CA 90039
 Phone: (323) 666-5284 / Fax: (323) 665-0328
 www.rutherfordco.net

Date:	01/28/19
RCI Job #:	16-075
RCI COR #:	109
GC Tracking #:	

CHANGE ORDER REQUEST

EMAIL: bgray@swinerton.com

TO: Swinerton Builders

ATTN.: Bill Gray

JOB NAME: **LEMONWOOD K-8 SCHOOL:**

DESCRIPTION OF WORK:

OTP #32386: Drywall work at Admin Building; Pony Walls. Demo 2 openings to TV's and clean up.

BREAKDOWN:		HR. RATE	QTY.	UNIT	AMOUNT	COMMENTS
LABOR	Regular-Journeyman	\$78.60	16	HRS	\$ 1,257.60	
	Regular-Foreman	\$0.00	0	HRS	\$ -	
	Regular-Superintendent	\$0.00	0	HRS	\$ -	
	Safety/QC Manager	\$0.00	0	HRS	\$ -	
	Overtime-Journeyman	\$0.00	0	HRS	\$ -	
	Doubletime-Journeyman	\$0.00	0	HRS	\$ -	
MATERIAL		\$188.00	0	Tax	\$ 205.86	
EQUIPMENT	Scissor Lift	\$0.00	0	Day		
	Dumpster	\$0.00	0	ea.		
		\$0.00	1	Day	\$ -	
SCAFFOLD		\$0.00	0	Day	\$ -	
SUBS/MISC.						
FREIGHT/DELIVERY		\$200.00	0	LS	\$ -	
		\$0.00	0	LS	\$ -	
		\$0.00	0	LS	\$ -	
SUBTOTAL					\$ 1,463.46	
15.0% OHP MARKUP					\$ 219.52	
COR TOTAL:					\$ 1,683	

QUALIFICATIONS

- ADDITIONAL TIME MAY BE REQUIRED ON THE PROJECT SCHEDULE FOR THE WORK DESCRIBED ABOVE
- ALL GAS/ELECTRIC EQUIPMENT USED FOR THIS COR WILL BE CHARGED AT A 1-DAY MINIMUM RENTAL

"THIS PROPOSAL IS FOR THE DESCRIBED WORK ONLY. PRICING IS BASED ON THE CURRENT PROJECT STATUS. RUTHERFORD IS ENTITLED TO COMPENSATION FOR ADDITIONAL COSTS IF THE PROJECT STATUS CHANGES BEFORE APPROVAL. FURTHERMORE, THE STATED PRICE DOES NOT INCLUDE ANY AMOUNT FOR COSTS RESULTING FROM IMPACTS, WHETHER THE IMPACTS ARE CAUSED BY SCHEDULING, RESCHEDULING, OUT OF SEQUENCE OPERATIONS, TRADE CONGESTION, OTHER DISRUPTIONS, DELAYS OR ACCELERATION. RUTHERFORD EXPRESSLY RESERVES THE RIGHT TO COLLECT FULL OVERHEAD AND PROFIT FOR ANY OF SUCH IMPACTS."

Submitted By:

Project Manager

Approved By:

RUTHERFORD CO INC

Lath/Plaster/Drywall/Fireproofing/EIFS
 2107 Crystal Street
 Los Angeles, California 90039
 Telephone (323) 666.5285

ORDER TO PROCEED NO.: 32386

DATE: 1-16-19

DAY OF THE WEEK: Wed.

RCI EMPLOYEE: Don Elder

AUTHORIZATION FOR EXTRA WORK

COR # 109

PROJECT: Lemonwood JOB NO.: 17-084

LOCATION OF WORK:	PAGE:	COLUMNS:	DETAIL:
		THRU	

DESCRIPTION:

Per. Mark with Swinerton we were to hang drywall in Admin. at Party walls, and trim and Demo two openings for add T.V.'s 1-4'x4' and 1-4'x8'.
 Clean-up
 Taping to follow

LABOR & MATERIAL BREAKDOWN

FIELD LABOR - NO. OF MEN:	NO. OF HRS EA MAN WORKED	TOTAL HRS	MATERIALS
2	8 HRS	16 HRS	14 pcs. 4'x8' 5/8" Drywall
			6 pcs. Corner Board 10'
			4 pcs L-metal 10'
DELIVERY MAN HOURS:			
TOTAL MEN:		TOTAL:	
		16 HRS	

1686
12
8

EQUIPMENT RENTAL: (1 DAY MINIMUM ON ALL RENTALS)

TRUCKING _____ SCISSOR LIFTS _____ FIREPROOF PUMPS _____
 WELDERS _____ BOOM LIFT _____ MIXERS _____
 COMPRESSORS _____ CEMENT PUMPS _____ SCAFFOLD _____
 ROLLING UNITS _____ FORKLIFTS _____

WORK ACCEPTED & COMPLETED
 WORK ONGOING

AUTHORIZED SIGNER: [Signature] 1/16/19

CONTRACTOR: Swinerton

DATE: 1-16-19

RCI COR#

PRINTED NAME: _____



SWINERTON

November 20, 2018

Oxnard School District
1051 South A Street
Oxnard, CA, 93030

Attn: Mario Mera

Subject: Swinerton Builders Job 16055106 - Lemonwood K-8 School LLB
PCI No. 0426R1 Remove and replace existing Fronteir Communications underground pull box

Dear Mr. Mera,

We request a Change Order to our contract for the following:

Existing pull box located on San Mateo adjacent to Lemonwood Park currently sits out of the concrete sidewalk creating a trip hazard. Frontier has provided a new box, but not install. Cost is to install provider furnished box

Phase	Category	Description	Subcontractor	Quote
260010	71140	Install new Frontier Communication pull box	TAFT ELECTRIC COMPANY	3,964.00
			Subtotal	3,964.00
007480	71160	Subguard	1.15%	45.59
007410	71160	Builders Risk	0.6%	24.06
007420	71160	General Insurance	1.15%	46.11
007510	71160	P&P Bond	1%	39.64
991000	79999	Change Order Fee	5%	203.99
			Markup Subtotal	359.39
			PCI Total	4,323.39

TOTAL AMOUNT OF THIS CHANGE ORDER REQUEST: **4,323.39.**

Please NOTE:

- » The incorporation of this revision in to the contractual scope of work may have an impact on our schedule, which is yet to be finalized. Once determined, the job schedule will be adjusted accordingly to show the effect of this revision on the final project completion date..
- » The terms (cost and schedule impact) of this change order request are subject to review and a requote if not accepted within days of its issuance.
- » This request does not include additional cost or delay due to late approval.

We **HAVE** proceeded with this revised work per your instructions. Please issue a change order.



SWINERTON

Upon acceptance of this change order request, a formal change order will be issued. Acceptance also acknowledges that Swinerton Builders has proceeded with the above change in scope.

If you have any questions or comments pertaining to this matter, please contact the undersigned.

Sincerely,
Swinerton Builders

William
2/26/09

Date: _____

Quotation accepted by:
Oxnard School District

By: _____

Date: _____

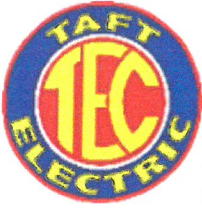

Taft Electric Company

1694 Eastman Avenue
Ventura, CA 93003

(805)642-0121
Contractor License # 772245

Change Order Request

Detailed, Grouped by Each Number

2241 Lemonwood
2200 Carnegie Court
Oxnard, CA 93033

Project # 2241
Tel: Fax:

Taft Electric Company

Change Order Request: 105 **Date:**

To: Bill Gray Swinerton Builders 865 S. Figueroa Street Los Angeles, CA 90017	From: Matt Gobuty Taft Electric Company P.O. Box 3416 Ventura, CA 93006
---	---

Description	Category	Status
Frontier Pullbox		Pending

Reference	Required By	Days Req	Amt Req
		0	\$3,964

Notes

We are submitting the above cost to swap out the Frontier telephone utility pullbox on the Southeast corner of campus. This work was done on T&M per the attached charge accumulations.

This quote is valid for 30 calendar days from the above date. We reserve our right to re-quote this proposal should the approval take longer than 30 days.

Attached is the back up for your review. Please call should you have any questions.

Matt Gobuty
Project Manager
(805)654-7994

PCO No	Date	Reference	Amt Prop	Days Req	Category	Reason
		Description	Notes			

Approved By:

Signature _____

Name _____ Date _____



SWINERTON

November 27, 2018

Oxnard School District
1051 South A Street
Oxnard, CA, 93030

Attn: Mario Mera

Subject: Swinerton Builders Job 16055106 - Lemonwood K-8 School LLB
PCI No. 0433 Add sliding marker board stops and bumpers

Dear Mr. Mera,

We request a Change Order to our contract for the following:

Add stops and bumpers to sliding marker board panels in the Kindergarten Building rooms 101-104

Phase	Category	Description	Subcontractor	Quote
101100	71140	Add stops and bumpers to sliding marker board panels in the Kindergarten Building rooms 101-104	NELSON ADAMS NACO	2,500.00
			Subtotal	2,500.00
007480	71160	Subguard	1.15%	28.75
007410	71160	Builders Risk	0.6%	15.17
007420	71160	General Insurance	1.15%	29.08
007510	71160	P&P Bond	1%	25.00
991000	79999	Change Order Fee	5%	128.65
			Markup Subtotal	226.65
			PCI Total	2,726.65

TOTAL AMOUNT OF THIS CHANGE ORDER REQUEST: **2,726.65.**

Please NOTE:

- » The incorporation of this revision in to the contractual scope of work may have an impact on our schedule, which is yet to be finalized. Once determined, the job schedule will be adjusted accordingly to show the effect of this revision on the final project completion date.
- » The terms (cost and schedule impact) of this change order request are subject to review and a requote if not accepted within days of its issuance.
- » This request does not include additional cost or delay due to late approval.

We **HAVE NOT** proceeded with this revised work per your instructions. Please issue a change order.

Upon acceptance of this change order request, a formal change order will be issued. Acceptance also



SWINERTON

acknowledges that Swinerton Builders is directed to proceed with the above change in scope.

If you have any questions or comments pertaining to this matter, please contact the undersigned.

Sincerely,
Swinerton Builders

4/27/2019

Date: _____

Quotation accepted by:
Oxnard School District

By: _____

Date: _____

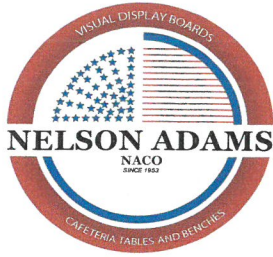

NELSON ADAMS NACO
 160 N. Cactus Ave.
 Rialto, CA 92376
 Lic: 971118
 PW: 100009263
 P: 877-810-4080

Change Order

Order#: 5
 Order Date: 11/27/2018
 Record#: 268

To: SWINERTON BUILDERS
 865 S. FIGUEROA ST
 SUITE 300
 LOS ANGELES CA 90017

Project: 524
 LEMONWOOD K-8
 2200 CARNIGIE CT
 OXNARD CA 93033

The contractor agrees to perform and the owner agrees to pay for the following changes to this contract.

Plans Attached

Ordered By: 22 DENIS LIZARRAGA

Customer Order: CURRENT

Specifications Attached

Description of Work	Amount
HARDWARE: BUMPERS & END-STOPS	1,460.00
LABOR	1,040.00

Negative changes will lower the overall contract price requiring no additional payment by owner.

Requested Amount of Change

2,500.00

The original Contract Sum was	268,780.00
Net change by previous Change Orders	0.00
The Contract Sum prior to this Change Order	268,780.00
The Contract Sum will be changed by this Change Order	2,500.00
The new Contract Sum including this Change Order will be	271,280.00
The Contract Time will be changed by	0 Days

Auth. Contractor: _____

Legible Name: _____

Signature: _____

Date: _____



SWINERTON

January 22, 2019

Oxnard School District
1051 South A Street
Oxnard, CA, 93030

Attn: Mario Mera

Subject: Swinerton Builders Job 16055106 - Lemonwood K-8 School LLB
PCI No. 0446R2 RFI 387 Relocate chain-link fence on Carnegie Court

Dear Mr. Mera,

We request a Change Order to our contract for the following:

Remove and relocate existing chain-link fence on Carnegie Court as described in RFI 387

Phase	Category	Description	Subcontractor	Quote
017416	71111	Relocate chain-link fence on Carnegie Court	SWINERTON	600.00
310010	71140	Remove existing concrete curb and gutter, as well as existing landscaping, excludes palm tree removal	GROUNDBREAKERS CONSTRUCTION INC	5,507.09
323100	71140	Remove and relocate existing chain-link fence on Carnegie Court as described in RFI 387	CROWN FENCE CO., INC.	9,750.00
			Subtotal	15,857.09
007480	71160	Subguard	1.15%	182.36
007410	71160	Builders Risk	0.6%	96.24
007420	71160	General Insurance	1.15%	184.45
007510	71160	P&P Bond	1%	152.57
991000	79999	Change Order Fee	5%	816.01
			Markup Subtotal	1,431.63
			PCI Total	17,288.72

TOTAL AMOUNT OF THIS CHANGE ORDER REQUEST: **17,288.72**.

Please NOTE:

- » The incorporation of this revision in to the contractual scope of work may have an impact on our schedule, which is yet to be finalized. Once determined, the job schedule will be adjusted accordingly to show the effect of this revision on the final project completion date..
- » The terms (cost and schedule impact) of this change order request are subject to review and a requote if not accepted within days of its issuance.



SWINERTON

» This request does not include additional cost or delay due to late approval.

X We **HAVE** proceeded with this revised work per your instructions. Please issue a change order.

Upon acceptance of this change order request, a formal change order will be issued. Acceptance also acknowledges that Swinerton Builders has proceeded with the above change in scope.

If you have any questions or comments pertaining to this matter, please contact the undersigned.

Sincerely,
Swinerton Builders

Date: 4/22/2019

Quotation accepted by:
Oxnard School District

By: _____

Date: _____

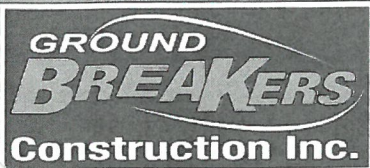

Grading • Excavation • Concrete

2292 Hayride Rd P.O. Box 520 Lebec, CA 93243

Office: 661.248.6490 Fax: 661.248.6489 groundbreakers@integrity.com

License #823501

Proposal / Contract

Date 1/11/19

Estimate # 1997

Proposed To:

Swinerton Builders
 Bill Gray
 17731 Mitchell North Suite 200
 Irvine, CA 92614

Job Information:

Lemonwood K-8
 2200 Carnegie Court
 Oxnard, CA 93033

Contact: Bill Gray
Phone #: 949-355-6822
Fax #: 949-477-3085
Email Address: bgray@swinerton.com

Per Plans By: C-6 Drainage
Engineer:
Drawing Info:
Permit #: N/A

Ground Breakers Construction Inc. will furnish all labor, materials, and equipment to construct and complete the following in a workman-like manner according to standard practices.

Item	Scope of Work	Quantity	Amount
E1	<p>C-6 Drainage Demolition E1 - DEMO / CLEARING Demo and remove AC paving under trailer in parking lot. Demo and remove planter, including shrubs, palm tree, etc. See attached for equipment, labor and dumping breakdown.</p> <p><i>Planter removal \$ 8007.09 - \$ 2500 = 5507.09</i> <i>A/c pavement removal \$ 6268</i></p>	LS	<p>14,275.09 2,500. \$ 11,775</p>

Work to commence on or before _____ and to be completed within _____ working days.

Total \$14,275.09

Customer Signature

Date

GBC Inc. Signature

Date

Please, read and initial the Ground Breakers General Contract for Products and Services on the reverse side.

Scope:
Demo Planter
and area under
trailer

Item	Unit Rate Inc. Tax and Freight	Quantity	Sub Total	Material Total	Equipment	Rate	Hrs	Equipment Total	Operator Hours	Operator Rate	Laborer Hours	Laborer Rate	Labor Total
Dump Fees	\$400.00	4.00	\$1,600.00	\$1,600.00	PC120	\$88.43	16.00	\$1,414.88	16.00	\$90.98	32.00	\$70.33	\$3,706.24
	\$0.00	0.00	\$0.00	\$0.00	End Dump	\$95.00	16.00	\$1,520.00	0.00	\$90.98	0.00	\$70.33	\$0.00
	\$0.00	0.00	\$0.00	\$0.00	Stump Grinder	\$150.00	8.00	\$1,200.00	0.00	\$90.98	0.00	\$60.91	\$0.00
	\$0.00	0.00	\$0.00	\$0.00	Dump Trailer	\$35.00	16.00	\$560.00	0.00	\$90.98	0.00	\$60.91	\$0.00
	\$0.00	0.00	\$0.00	\$0.00	Chain Saw	\$20.00	8.00	\$160.00	0.00	\$90.98	0.00	\$60.91	\$0.00
	\$0.00	0.00	\$0.00	\$0.00	Concrete Saw	\$20.00	4.00	\$80.00	0.00	\$90.98	0.00	\$60.91	\$0.00
	\$0.00	0.00	\$0.00	\$0.00	Mob/De-mob	\$1,500.00	1.00	\$1,500.00	0.00	\$90.98	0.00	\$60.91	\$0.00
	\$0.00	0.00	\$0.00	\$0.00				\$0.00		\$90.98		\$60.91	\$0.00
	\$0.00	0.00	\$0.00	\$0.00				\$0.00		\$90.98		\$60.91	\$0.00
	\$0.00	0.00	\$0.00	\$0.00				\$0.00		\$90.98		\$60.91	\$0.00
Sub-Total				\$1,600.00				\$6,434.88					\$3,706.24

	M/U
Total Material	240.00
Total Equipment	1066.03
Total labor	555.94
Total Cost	\$14,275.09

\$ 6067.09
To 1008

	Gall./hr.	Hours	
PC120	12.00	16.00	\$3.50/Gall.
WA500	11.00	0.00	\$3.50
T-650	6.00	0.00	\$3.50
84" Roller	5.00	0.00	\$3.50
D41	8.00	0.00	\$3.50
Fuel Total			\$672.00

3377.44
1737
45114 I
336
\$5450
\$ 6268

CROWN FENCE
 12118 Bloomfield Ave
 Santa Fe Springs CA 90670

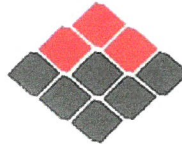

Since 1923

Phone: (562) 864-5177
 Fax: (562) 864-2529
 State Lic. 1315
 DIR 1000005330

PROJECT: <u>Lemonwood</u>	TO: <u>Swinerton Builders</u>
CONTACT: <u>Brian</u>	ATTENTION: <u>Bill Gray</u>
DATE: <u>12/14/2018</u>	FAX: _____
Plans: <u>Yes</u>	Bondable: <u>Yes</u>
Specs: <u>No</u>	Rate: <u>0.86%</u>
Installed: <u>Yes</u>	Tax: <u>Yes</u>
Wage: <u>PREVAILING</u>	EMR: <u>0.79</u>
** Crown Fence Co is Union Signatory to the Laborer's & Operating Engineers.	Addendum: <u>None</u>

ITEM	DESCRIPTION	QUANTITY	UNIT PRICE	AMOUNT
	Relocate about 150 LF of 6' tall galvanized chain link 7' forward to be in line with rest of perimeter fence. Relocate 1ea rolling gate as well. Posts in parking lot to be cut off at grade. Crown will reuse existing chain link and rail but will dig and set new posts and use new tension wire.	1 ea	\$ 9,750.00	\$ 9,750.00
	Add double swing gate instead of rolling gate \$1200			
			TOTAL	\$ 9,750.00

CLARIFICATIONS:

- Prime contractor to survey fence lines and stake/mark corner, end and gate post locations prior to installation.
- Excavation of post footings to be machine dug. The hand digging & pot holing allowance for the above mentioned project is 2 hours. Any further time needed will be at an additional hourly cost based upon man hours.
- Contractor or owner agrees to provide location of any and all utilities not covered by Dig Alert, which includes providing updated plan drawings, As-Builts, flagging and/or hiring a private Utility Locating Company. Therefore, Crown will not be responsible for any damages to such utilities not properly or accurately located.
- Crown will not be responsible for repair or replacement of any plastic utility lines or irrigation lines interfering or within close proximity of post footings.

EXCLUSIONS:

- | | | |
|---|-------------------------------------|------------------------------------|
| - SWPPP | - Masonary Walls / Cross Fences | - Maintenance |
| - Engineering / Structural Calculations | - Dust Control | - Gate Automation |
| - Auto CAD Drawings | - Grading / Clearing & Grubbing | - Panic Hardware / Specialty Locks |
| - Staking / Surveying / Pot-holing | - Fence / Gate Grounding | - Temporary Fencing & Gates |
| - Location of Underground Utilities | - Core Drilling / Saw Cutting | - Finish Paint |
| - Permits / Licenses & Fees | - Rock Drilling | - Inspection / Testing Fees |
| - Traffic Control / Flagmen | - Patching / Restoration | - Asbestos Training / Costs |
| - Fence removal / disposal | - Removal of Spoils From Site | - Bond Premium |
| | - Concrete other than post footings | - Builder's Risk Insurance |

Additional fees may apply for project requirements not provided or disclosed prior to bidding. Such fees include Special Insurances, Payroll (Textura), Bonds, Finger Printing & Background Checks, Special Badging or Clearances.



SWINERTON

Oxnard School District
1051 South A Street
Oxnard, CA, 93030

Attn: Mario Mera

Subject: Swinerton Builders Job 16055106 - Lemonwood K-8 School LLB
PCI No. 0447 Bulletin 58 Chain link fence revisions

Dear Mr. Mera,

We request a Change Order to our contract for the following:

Bulletin 58 revised chain link fence layout between Administration and MPR Buildings. Portions of previously installed concrete had to be removed and replaced to accomplish this work.

Phase	Category	Description	Subcontractor	Quote
321216	71140	Bulletin 58 saw cut and remove concrete for chain link revisions	BC RINCON CONSTRUCTION, INC.	747.50
321313	71140	Bulletin 58 revised chain link fence layout between Administration and MPR Buildings. Portions of previously installed concrete had to be removed and replaced to accomplish this work	SANTA CLARITA CONCRETE	2,083.39
			Subtotal	2,830.89
007480	71160	Subguard	1.15%	32.56
007410	71160	Builders Risk	0.6%	17.18
007420	71160	General Insurance	1.15%	32.93
007510	71160	P&P Bond	1%	28.31
991000	79999	Change Order Fee	5%	145.68
			Markup Subtotal	256.66
			PCI Total	3,087.55

TOTAL AMOUNT OF THIS CHANGE ORDER REQUEST: **3,087.55.**

Please NOTE:

- » The incorporation of this revision in to the contractual scope of work may have an impact on our schedule, which is yet to be finalized. Once determined, the job schedule will be adjusted accordingly to show the effect of this revision on the final project completion date..
- » The terms (cost and schedule impact) of this change order request are subject to review and a requote if



SWINERTON

not accepted within days of its issuance.

- » This request does not include additional cost or delay due to late approval.

X We **HAVE** proceeded with this revised work per your instructions. Please issue a change order.

Upon acceptance of this change order request, a formal change order will be issued. Acceptance also acknowledges that Swinerton Builders has proceeded with the above change in scope.

If you have any questions or comments pertaining to this matter, please contact the undersigned.

Sincerely,
Swinerton Builders

W. P. Khan
2/06/2019

Date: _____

Quotation accepted by:
Oxnard School District

By: _____

Date: _____



BC RINCON CONSTRUCTION, INC.

67 East La Loma Avenue Somis CA 93066

Phone: 805-981-0690 Fax: 805-485-4705

AR@BCRINCON.COM

JOB #: 16-123 CCO#10

DATE: 12/6/2018

TO: Swinerton Builders

17731 Mitchell North, Suite 200

Irvine, CA

PROJECT: 2200 Carnegie Ct., Oxnard, CA 93033

DESCRIPTION: Saw Cutting

	<u>QTY</u>		<u>UNIT</u>	<u>AMOUNT</u>
1) Saw Cut, Break, & Remove Reinforced Concrete	1	LS	\$650.00	\$650.00
2) Overhead & Profit 15%	1	LS	\$97.50	\$97.50
				<hr/>
		Total		\$747.50

Original Contract	<u>\$464,411.00</u>
Other Approved Change Orders	<u>\$9,304.92</u>
This Request	<u>\$747.50</u>
Other Pending Request	<u>\$14,525.11</u>
Total Contract and Approved Change Orders	<u>\$473,715.92</u>

Authorized Signature: 
BC Rincon Construction

Date: 12/6/18

Authorized Signature: _____

Date: _____



16164 Sierra Highway
 Santa Clarita, CA 91390
 Phone 661.252.2012
 Fax 661.298.4585
 CA License No. 381605

CHANGE ORDER REQUEST

COR	SCC-027
P&O	15.00%
SUB P&O	5.00%
BOND	1.00%
REVISION	Original submission

PROJECT	Lemonwood
OWNER/REP	Swinerton Construction
ATTN	Bill Gray
DATE	2/4/19
REFERENCE	PCI-0447

NARRATIVE FOR CHANGE ORDER REQUEST

Provide labor, equipment and materials to perform additional scope as requested by Swinerton Builders: demo, remove and replace concrete for new fence between Admin and MPR buidings.

REF	DESC	LOC	DATE	CATEGORY	TYPE	R/OT	QTY	UNIT	RATE	TOTAL
AWA-10568	New conc	Admin/MPR	12/14/19	Unit	City sidewalk	R	54	Sf	\$15.00	\$810.00
AWA-10568	Speed dowels	Admin/MPR	12/14/19	Unit	Speed dowels	R	26	Ea	\$33.00	\$872.14
AWA-10568	Felt/Acap	Admin/MPR	12/14/19	Unit	Felt/A-Cap	R	37	Lf	\$3.50	\$129.50

EXCLUSIONS/QUALIFICATIONS

Price assumes work to be done concurrently with other work.
 Separate mobilization will require additional costs.
 Bond is not included in this COR
 All work done as directed by Swinerton Builders
 SCC assumes no responsibility for damage to adjacent surfaces/landscaping for any reason.

EXTENSION OF CONTRACT DURATION---->

1 Day

SUB-TOTAL	\$1,811.64
P&O	\$271.75
TOTAL FOR THIS COR	\$2,083.39



SWINERTON

March 4, 2019

Oxnard School District
1051 South A Street
Oxnard, CA, 93030

Attn: Mario Mera

Subject: Swinerton Builders Job 16055106 - Lemonwood K-8 School LLB
PCI No. 0451R1 Install two (2) concrete monument bases

Dear Mr. Mera,

We request a Change Order to our contract for the following:

Furnish and install two (2) concrete pedestal monument base to locations directed by others (vehicular equipment accessible).

Phase	Category	Description	Subcontractor	Quote
329000	71140	Furnish and install concrete pedestal monument base to location directed by others (vehicular equipment accessible).	PIERRE LANDSCAPE	9,799.00
			Subtotal	9,799.00
007480	71160	Subguard	1.15%	112.69
007410	71160	Builders Risk	0.6%	59.47
007420	71160	General Insurance	1.15%	113.99
007510	71160	P&P Bond	1%	97.99
991000	79999	Change Order Fee	5%	504.26
			Markup Subtotal	888.40
			PCI Total	10,687.40

TOTAL AMOUNT OF THIS CHANGE ORDER REQUEST: **10,687.40.**

Please NOTE:

- » The incorporation of this revision in to the contractual scope of work may have an impact on our schedule, which is yet to be finalized. Once determined, the job schedule will be adjusted accordingly to show the effect of this revision on the final project completion date.
- » The terms (cost and schedule impact) of this change order request are subject to review and a requote if not accepted within days of its issuance.
- » This request does not include additional cost or delay due to late approval.

 X We **HAVE NOT** proceeded with this revised work per your instructions. Please issue a change order.



SWINERTON

Upon acceptance of this change order request, a formal change order will be issued. Acceptance also acknowledges that Swinerton Builders is directed to proceed with the above change in scope.

If you have any questions or comments pertaining to this matter, please contact the undersigned.

Sincerely,
Swinerton Builders

Date: 3/4/2019

Quotation accepted by:
Oxnard School District

By: _____

Date: _____



To: Swinerton Builders
Attn: Bill Gray
Email: bgray@swinerton.com
Project: Lemonwood ES

From: Scott Horner
Job #: 22589
Date: 09/20/18

Change Order Request #: 7.1

Subject: Pierre's cost to provide and install (2) custom precast concrete monument bases.

DESCRIPTION	QTY	UNIT	UNIT PRICE	EXTENDED
LABOR				
LABOR ADDED				
Foreman Labor	16	Hrs	\$ 77.57	\$ 1,241.12
Journeyman Labor	16	Hrs	\$ 67.91	\$ 1,086.56
Apprentice Labor	16	Hrs	\$ 59.50	\$ 952.00
MATERIAL				
LANDSCAPE MATERIAL ADDED				
22" W x 44" L x 22" H Custom Precast Concrete Podium for Bronze Plaque	1	EA	\$ 3,564.30	\$ 3,564.30
20" W x 44" L x 22 H ustom Precast Concrete Podium for (2) plaques measuring 16" x 12" and 5" x 3 1/2"	1	EA	\$ 3,564.30	\$ 3,564.30
Misc Hardware / Aggregate Base	1	LS	\$ 392.40	\$ 392.40
EQUIPMENT (INCLD FUEL)				
Reach Lift	2	DAY	\$ 195.00	\$ 390.00
Equipment Delivery and Pick Up	1	LS	\$ 200.00	\$ 200.00
Crew Truck	2	DAY	\$ 95.00	\$ 190.00
			\$ -	\$ -

Subtotal	\$	11,581
Sales Tax		Incl
15% Markup	\$	1,737
Maintenance	\$	-
Bond	\$	200
TOTAL	\$	13,518

\$1000

\$7521

8521

1278

9799

Based on this additional work, **2** day(s) will be added to our current work schedule
Thank you,
 Scott Horner



SWINERTON

January 16, 2019

Oxnard School District
1051 South A Street
Oxnard, CA, 93030

Attn: Mario Mera

Subject: Swinerton Builders Job 16055106 - Lemonwood K-8 School LLB
PCI No. 0455 Remove Phase I temporary asphalt walkway surfaces

Dear Mr. Mera,

We request a Change Order to our contract for the following:

As part of the campus circulation re-routing necessary to provide a safe access for students and staff to and from the temporary Administration offices and the new campus, a temporary asphalt surface was created to facilitate this path. This asphalt must now be removed to complete Phase II site improvements.

Phase	Category	Description	Subcontractor	Quote
310010	71140	As part of the campus circulation re-routing necessary to provide a safe access for students and staff to and from the temporary Administration offices and the new campus, a temporary asphalt surface was created to facilitate this path. This asphalt must now be removed to complete Phase II site improvements.	Groundbreakers Construction Inc	6,268.00
			Subtotal	6,268.00
007480	71160	Subguard	1.15%	72.08
007410	71160	Builders Risk	0.6%	38.04
007420	71160	General Insurance	1.15%	72.91
007510	71160	P&P Bond	1%	62.68
991000	79999	Change Order Fee	5%	322.55
			Markup Subtotal	568.26
			PCI Total	6,836.26

TOTAL AMOUNT OF THIS CHANGE ORDER REQUEST: **6,836.26.**

Please NOTE:

- » The incorporation of this revision in to the contractual scope of work may have an impact on our schedule, which is yet to be finalized. Once determined, the job schedule will be adjusted accordingly to show the effect of this revision on the final project completion date.
- » The terms (cost and schedule impact) of this change order request are subject to review and a requote if not accepted within days of its issuance.
- » This request does not include additional cost or delay due to late approval.



SWINERTON

X We **HAVE NOT** proceeded with this revised work per your instructions. Please issue a change order.

Upon acceptance of this change order request, a formal change order will be issued. Acceptance also acknowledges that Swinerton Builders is directed to proceed with the above change in scope.

If you have any questions or comments pertaining to this matter, please contact the undersigned.

Sincerely,
Swinerton Builders

1/16/2019

Date: _____

Quotation accepted by:
Oxnard School District

By: _____

Date: _____

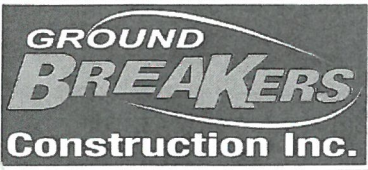

Grading • Excavation • Concrete

2292 Hayride Rd P.O. Box 520 Lebec, CA 93243

Office: 661.248.6490 Fax: 661.248.6489 groundbreakers@integrity.com

License #823501

Proposal / Contract

Date 1/11/19

Estimate # 1997

Proposed To:

Swinerton Builders
Bill Gray
17731 Mitchell North Suite 200
Irvine, CA 92614

Job Information:

Lemonwood K-8
2200 Carnegie Court
Oxnard, CA 93033

Contact: Bill Gray
Phone #: 949-355-6822
Fax #: 949-477-3085
Email Address: bgray@swinerton.com

Per Plans By: C-6 Drainage
Engineer:
Drawing Info:
Permit #: N/A

Ground Breakers Construction Inc. will furnish all labor, materials, and equipment to construct and complete the following in a workman-like manner according to standard practices.

Item	Scope of Work	Quantity	Amount
E1	<p>C-6 Drainage Demolition E1 - DEMO / CLEARING Demo and remove AC paving under trailer in parking lot. Demo and remove planter, including shrubs, palm tree, etc. See attached for equipment, labor and dumping breakdown.</p> <p><i>Planter removal \$ 8007.09</i> <i>A/c pavement removal \$ 6268</i></p>	LS	14,275.09

Work to commence on or before _____ and to be completed within _____ working days.

Total \$14,275.09

Customer Signature

Date

GBC Inc. Signature

Date

Please, read and initial the Ground Breakers General Contract for Products and Services on the reverse side.

Scope:
Demo Planter
and area under
trailer

Item	Unit Rate Inc. Tax and Freight	Quantity	Sub Total	Material Total	Equipment	Rate	Hrs	Equipment Total	Operator Hours	Operator Rate	Laborer Hours	Laborer Rate	Labor Total
Dump Fees	\$400.00	4.00	\$1,600.00	\$1,600.00	PC120	\$88.43	16.00	\$1,414.88	16.00	\$90.98	32.00	\$70.33	\$3,706.24
	\$0.00	0.00	\$0.00	\$0.00	End Dump	\$95.00	16.00	\$1,520.00	0.00	\$90.98	0.00	\$70.33	\$0.00
	\$0.00	0.00	\$0.00	\$0.00	Stump Grinder	\$150.00	8.00	\$1,200.00	0.00	\$90.98	0.00	\$60.91	\$0.00
	\$0.00	0.00	\$0.00	\$0.00	Dump Trailer	\$35.00	16.00	\$560.00	0.00	\$90.98	0.00	\$60.91	\$0.00
	\$0.00	0.00	\$0.00	\$0.00	Chain Saw	\$20.00	8.00	\$160.00	0.00	\$90.98	0.00	\$60.91	\$0.00
	\$0.00	0.00	\$0.00	\$0.00	Concrete Saw	\$20.00	4.00	\$80.00	0.00	\$90.98	0.00	\$60.91	\$0.00
	\$0.00	0.00	\$0.00	\$0.00	Mob/De-mob	\$1,500.00	1.00	\$1,500.00	0.00	\$90.98	0.00	\$60.91	\$0.00
	\$0.00	0.00	\$0.00	\$0.00				\$0.00		\$90.98		\$60.91	\$0.00
	\$0.00	0.00	\$0.00	\$0.00				\$0.00		\$90.98		\$60.91	\$0.00
	\$0.00	0.00	\$0.00	\$0.00				\$0.00		\$90.98		\$60.91	\$0.00
Sub-Total			\$1,600.00	\$1,600.00				\$6,434.88					\$3,706.24

3377.44
1737
451144
336
\$5450
44

\$6268

Total Material	M/U	Hours	Gall./hr.	Fuel:	Equipment Total	Operator Hours	Laborer Hours
\$1,600.00	240.00	16.00	12.00	PC120	16.00	\$672.00	32.00
\$7,106.88	1066.03	0.00	11.00	WA500	0.00	\$0.00	0.00
\$3,706.24	555.94	0.00	6.00	T-650	0.00	\$0.00	0.00
		0.00	5.00	84" Roller	0.00	\$0.00	0.00
		0.00	8.00	D41	0.00	\$0.00	0.00
				Fuel Total		\$672.00	
Total Cost							

\$14,275.09
To 1008
\$



SWINERTON

January 17, 2019

Oxnard School District
1051 South A Street
Oxnard, CA, 93030

Attn: Mario Mera

Subject: Swinerton Builders Job 16055106 - Lemonwood K-8 School LLB
PCI No. 0456 Furnish trees to City of Oxnard in exchange for tree removal

Dear Mr. Mera,

We request a Change Order to our contract for the following:

In consideration of OSD providing 13 each 24" box New Zealand Christmas tree to the City of Oxnard Parks Dept., the City of Oxnard has agreed to remove the two large trees on either side of the west, or exit, approach to the parking lot.

Phase	Category	Description	Subcontractor	Quote
329000	71140	In consideration of OSD providing 13 each 24" box New Zealand Christmas tree to the City of Oxnard Parks Dept., the City of Oxnard has agreed to remove the two large trees on either side of the west, or exit, approach to the parking lot.	PIERRE LANDSCAPE	3,443.00
			Subtotal	3,443.00
007480	71160	Subguard	1.15%	39.60
007410	71160	Builders Risk	0.6%	20.90
007420	71160	General Insurance	1.15%	40.05
007510	71160	P&P Bond	1%	34.43
991000	79999	Change Order Fee	5%	177.18
			Markup Subtotal	312.16
			PCI Total	3,755.16

TOTAL AMOUNT OF THIS CHANGE ORDER REQUEST: **3,755.16.**

Please NOTE:

- » The incorporation of this revision in to the contractual scope of work may have an impact on our schedule, which is yet to be finalized. Once determined, the job schedule will be adjusted accordingly to show the effect of this revision on the final project completion date.
- » The terms (cost and schedule impact) of this change order request are subject to review and a requote if not accepted within days of its issuance.
- » This request does not include additional cost or delay due to late approval.

X We **HAVE NOT** proceeded with this revised work per your instructions. Please issue a change order.



SWINERTON

Upon acceptance of this change order request, a formal change order will be issued. Acceptance also acknowledges that Swinerton Builders is directed to proceed with the above change in scope.

If you have any questions or comments pertaining to this matter, please contact the undersigned.

Sincerely,
Swinerton Builders

Date: 1/17/2019

Quotation accepted by:
Oxnard School District

By: _____

Date: _____



To: Swinerton Builders
Attn: Bill Gray
Email: bgray@swinerton.com
Project: Lemonwood ES

From: Scott Horner
Job #: 22589
Date: 01/17/19

Change Order Request #: 9.1

Subject: Pierre's cost to provide (13) 24" box New Zealand Christmas Trees. Cost reflects material and delivery only. Cost excludes installation and re-mobilization to receive and offload the shipment.

DESCRIPTION	QTY	UNIT	UNIT PRICE	EXTENDED
MATERIAL				
LANDSCAPE MATERIAL ADDED				
24" Box Metrosideros Excesus (New Zealand Christmas Tree)	13	EA	\$ 218.00	\$ 2,834.00
Delivery	1	LS	\$ 160.00	\$ 160.00
			\$ -	\$ -

	Subtotal	\$ 2,994
	Sales Tax	Incl
15%	Markup	\$ 449
	Maintenance	\$ -
	Bond	\$ -
	TOTAL	\$ 3,443

***Based on this additional work,

day(s) will be added to our current work schedule***

Thank you,
 Scott Horner

Project Manager
 Cell: (818) 683-2067

PE _____
 PM _____
 RS _____
 JL _____



SWINERTON

January 23, 2019

Oxnard School District
1051 South A Street
Oxnard, CA, 93030

Attn: Mario Mera

Subject: Swinerton Builders Job 16055106 - Lemonwood K-8 School LLB
PCI No. 0458 RFI #390 EWH-2 Bldg 3 and 4

Dear Mr. Mera,

We request a Change Order to our contract for the following:

Add aquastat, time clock, expansion tank and related piping for EWH-2 in Building 3 and expansion tank and piping for Building 4.

Phase	Category	Description	Subcontractor	Quote
220010	71140	Plumbing	CITY COMMERCIAL PLUMBING, INC.	4,680.00
			Subtotal	4,680.00
007480	71160	Subguard	1.15%	53.82
007410	71160	Builders Risk	0.6%	28.40
007420	71160	General Insurance	1.15%	54.44
007510	71160	P&P Bond	1%	46.80
991000	79999	Change Order Fee	5%	240.83
			Markup Subtotal	424.29
			PCI Total	5,104.29

TOTAL AMOUNT OF THIS CHANGE ORDER REQUEST: **5,104.29.**

Please NOTE:

- » The incorporation of this revision in to the contractual scope of work may have an impact on our schedule, which is yet to be finalized. Once determined, the job schedule will be adjusted accordingly to show the effect of this revision on the final project completion date..
- » The terms (cost and schedule impact) of this change order request are subject to review and a requote if not accepted within days of its issuance.
- » This request does not include additional cost or delay due to late approval.

We **HAVE** proceeded with this revised work per your instructions. Please issue a change order.



SWINERTON

Upon acceptance of this change order request, a formal change order will be issued. Acceptance also acknowledges that Swinerton Builders has proceeded with the above change in scope.

If you have any questions or comments pertaining to this matter, please contact the undersigned.

Sincerely,
Swinerton Builders

Quotation accepted by:
Oxnard School District

Date: _____

By: _____

Date: _____



CITY COMMERCIAL PLUMBING, INC.
Plumbing Contractors and Consultants

16106 Cohasset St., Van Nuys, California 91406

(818) 785-1145

Fax: (818) 785-0588

EXTRA WORK ORDER SUBMITTAL

January 7, 2019

TO: SWINERTON BUILDERS

ATTENTION: BILL GRAY

JOB NAME: LEMONWOOD K-8

EXTRA WORK ORDER NO: CCP Inc., C.O.R.#56

DESCRIPTION: RFI#390 - BUILDING 3 & 4
ADD AQUASTAT, TIME CLOCK, EXPANSION TANK AND RELATED PIPING AT BUILDING#3, ADD EXPANSION TANK AND RELATED PIPING AT BUILDING#4 WATER HEATER.

TOTAL COSTT: \$4,680.00

Escalation rate of 1.5% / month will apply all unpaid change orders. Change order pricing assumes conditions existing as of date submitted. We reserve the right to adjust pricing if conditions change. Change orders should not be subject to retention. Request 1 days extension to complete this change order. We reserve the right to assess the cumulative impact of change.

This is the cost to add the scope to our contract. This proposal is void unless a written Change Order is received within 30 calendar days from the date of this Extra Work Order Submittal. Please send a Subcontract Change Order if you would like us to proceed with the extra work. This change order represents the work described only in this proposal. If the proposal is incomplete, we reserve the right to revise our price. We encourage you to review the scope of work we are offering to make sure it is in line with the changes.

If an owner-initiated change order is not accepted and authorized, City Commercial Plumbing demands reimbursement for all costs incurred in the preparation of the quote. If you have any questions or need clarification please call.

Sincerely,
CITY COMMERCIAL PLUMBING, INC

Cindy Snyder, Project Manager

Enclosures

CITY COMMERCIAL PLUMBING, INC.

16106 COHASSET STREET
 VAN NUYS, CA 91406
 (818) 785-1145

CONTRACTOR: SWINERTON BUILDERS
 17731 MITCHELL NORTH, SUITE 200
 IRVINE, CA 92614

JOB NAME: LEMONWOOD K-8
 2200 CARNEGIE COURT
 OXNARD, CA 93033

CCP JOB NO.: 562

CHANGE ORDER NO. 56

RE: RFI#390 - AQUASTAT/TIMER/EXP TANK TO BLDG 3, ADD EXP TANK TO BLDG 4

LABOR:	WAGES	HOURS	TOTAL
GEN FOREMAN	109.60	1.00	109.60
FOREMAN	102.90	11.46	1,179.23

TOTAL LABOR: 1,288.83

OTHER EXPENSE:

TOTAL OTHER EXP.: 0.00

OTHER EXPENSE:		0.00
MATERIAL TOTAL:		2,773.42
LABOR TOTAL:		1,288.83
SUBTOTAL:		4,062.25
OVERHEAD/PROFIT:	15.00%	609.34
SUBTOTAL:		4,671.59
TEXTURA FEES:	0.18%	8.41
SUBTOTAL:		4,680.00
		0.00
		4,680.00
ROUND UP/DOWN:		<u>\$4,680.00</u>

NOTES:

CITY COMMERCIAL PLUMBING, INC.**MATERIAL LIST**

JOB: LEMONWOOD K-8
 2200 CARNEGIE COURT
 OXNARD, CA 93033

CCP JOB NO.: 562

CHANGE ORDER NO. 56

RE: RFI#390 - AQUASTAT/TIMER/EXP TANK TO BLDG 3, ADD EXP TANK TO BLDG 4

QTY.	U/M	MATERIAL NAME	LAB U.	T. LAB.	MAT.COST	T. MAT
		MATERIAL		11.46		2544.42
		GEN FOREMAN - LAYOUT/COORD		1.00		
LABOR & MATERIAL TOTAL				12.46		2544.42
SALES TAX:					9.00%	229.00
<u>TOTAL MATERIAL COST:</u>						2773.42

NOTES

Item				Material		Field Labor	
Category	Size	Item Desc	Qty	Mat Unit	Mat Ext	Fld Unit	Fld Ext
Section : Section 037: COR#56 - RFI#390 ADD AQUASTAT/TIMER/EXP							
Category : Category 003: COPPER KLM LEAD FREE							
COPPER KLM LEAD FR...		3/4"Cx1/2"FIP ADAPTER	1	21.55	21.55	0.57	0.57
COPPER KLM LEAD FR...	3/4"	90 ELBOW CxC	4	4.20	16.80	0.53	2.12
COPPER KLM LEAD FR...	3/4"	ADAPTER CxF	2	13.80	27.60	0.69	1.38
COPPER KLM LEAD FR...	3/4"	TEE	1	7.71	7.71	0.77	0.77
COPPER KLM LEAD FR...	Unsize	SOLDER LBS. LEADFREE	1	39.48	39.48	Skip	0.00
COPPER KLM LEAD FR...	Unsize	PRESTOLITE -#2 CYL.	1	37.44	37.44	Skip	0.00
COPPER KLM LEAD FR...	1" x3/4"	REDUCED TEE - BRANCH	1	23.68	23.68	0.85	0.85
COPPER KLM LEAD FR...	1-1/4" x3/4"	REDUCED TEE - BRANCH	1	34.48	34.48	0.90	0.90
COPPER KLM LEAD FR...	Unsize	EVERFLUX--2 OZ. CAN	1	9.75	9.75	Skip	0.00
Subtotals for Category : Category 003: COPPER KLM LEAD FREE					218.49		6.59
Category : Category 049: HANGER-R.CLAMP-ETC.							
HANGER-R.CLAMP-ETC.	1-5/8"	STRUT CHANNEL	3	3.16	9.48	0.20	0.60
HANGER-R.CLAMP-ETC.	10"	STRUT CLAMP	2	11.07	22.14	0.35	0.70
Subtotals for Category : Category 049: HANGER-R.CLAMP-ETC.					31.62		1.30
Category : Category 051: HVAC SPECIALTIES							
HVAC SPECIALTIES	3/4" x3-1/2"	THERMOWELL	1	35.26	35.26	0.17	0.17
Subtotals for Category : Category 051: HVAC SPECIALTIES					35.26		0.17
Category : Category 053: PLUMBING SPECIALTIES							
PLUMBING SPECIALTIES	Unsize	AQUASTAT	1	193.06	193.06	1.00	1.00
Subtotals for Category : Category 053: PLUMBING SPECIALTIES					193.06		1.00
Category : Category 057: PLUMBING EQUIPMENT							
PLUMBING EQUIPMENT	1"	EXPANSION TANK	2	993.18	1,986.36	1.00	2.00
PLUMBING EQUIPMENT	Unsize	TIME CLOCK	1	79.63	79.63	0.40	0.40
Subtotals for Category : Category 057: PLUMBING EQUIPMENT					2,065.99		2.40
Subtotals for Section : Section 037: COR#56 - RFI#390 ADD AQUASTAT/TIMER/EXP					2,544.42		11.46
Grand Totals					2,544.42		11.46



SWINERTON

Request For Information # 00390

To:	SVA ARCHITECTS, INC.	RFI Date:	12/19/2018
Attention:	Tom Bardwell	Date Due:	12/19/2018
CC:	Paul Vernier	RFI Type:	Plumbing
	Bill Gray	Priority:	Critical
	Mark Trail	Schedule/Activity ID:	
		Document Reference:	
		Spec Section:	22000
		Status:	Returned

Subject: Are Circulating Pumps, Aquastats, expansion tanks, smitty pans and time clocks required for the EWH-2 electric water heaters in BLDG #3 & #4

INFORMATION REQUESTED:

Requested By: Nalani Scanlon

The Plumbing Plans do not provide a detail for the EHW-2 electric water heaters. There is an EWH-2 located in Rm# 3-116 in BLDG #3 and in Rm# 4-112 in BLDG #4. Do these EWH-2's require circulating pumps, aquastats, expansion tanks, smitty pans and time clocks? Please verify asap.

SUGGESTION:

Possible Cost Impact: Potentially

Possible Time Impact: Potentially

ANSWER:

Answered By: Tom Bardwell

Date of Response: 12/20/2018

Building 3: Sheet P3-11.1 shows CP-2 and hot water return piping. Aquastat and time clock will be required to turn the pump on and off. The code required expansion tank is also required, use Amtrol ST-5c or equal. Detail 4, sheet P-51.1 is a gas water heater, but the detail can be used for the piping and pump configuration, minus the gas piping and flue. Use B&G NRF-9F/LW circ. pump 115 v, with TC-1 Automatic timer kit 113210. Power has been provided already and is shown on E3.21, keynote 6.

Building 4: Requires the same expansion tank, but no circulation pump, aquastat or time clock. Water heater serves mop sink only.

Jeff Walker, Tk1sc
12/20/18

ATTACHMENTS:



SWINERTON

January 25, 2019

Oxnard School District
1051 South A Street
Oxnard, CA, 93030

Attn: Mario Mera

Subject: Swinerton Builders Job 16055106 - Lemonwood K-8 School LLB
PCI No. 0460 CCD 29 Marquee mounting

Dear Mr. Mera,

We request a Change Order to our contract for the following:

In order to raise the LED marquee off the ground out of vandals' reach, the mounting has been revised from a concrete base 30" off the ground, to a pole mount 10'0" off the ground

Phase	Category	Description	Subcontractor	Quote
101400	71140	CCD 29 Marquee mounting revisions	A GOOD SIGN & GRAPHICS CO	15,525.00
			Subtotal	15,525.00
007480	71160	Subguard	1.15%	178.54
007410	71160	Builders Risk	0.6%	94.22
007420	71160	General Insurance	1.15%	180.59
007510	71160	P&P Bond	1%	155.25
991000	79999	Change Order Fee	5%	798.92
			Markup Subtotal	1,407.52
			PCI Total	16,932.52

TOTAL AMOUNT OF THIS CHANGE ORDER REQUEST: **16,932.52**.

Please NOTE:

- » The incorporation of this revision in to the contractual scope of work may have an impact on our schedule, which is yet to be finalized. Once determined, the job schedule will be adjusted accordingly to show the effect of this revision on the final project completion date.
- » The terms (cost and schedule impact) of this change order request are subject to review and a requote if not accepted within days of its issuance.
- » This request does not include additional cost or delay due to late approval.

We **HAVE NOT** proceeded with this revised work per your instructions. Please issue a change order.

Upon acceptance of this change order request, a formal change order will be issued. Acceptance also



SWINERTON

acknowledges that Swinerton Builders is directed to proceed with the above change in scope.

If you have any questions or comments pertaining to this matter, please contact the undersigned.

Sincerely,
Swinerton Builders

Date: 4/25/2019

Quotation accepted by:
Oxnard School District

By: _____

Date: _____

A GOOD SIGN & GRAPHICS CO

COR # 02 rev4

Job Name: Lemonwood K-8 SCHOOL

Date: January 25, 2019

Time Impact:

Job Number: 1146

ASI#

Full Description of Change in Scope:

Change Marquee -Mount to Pole- Additional Costs

Breakdown		Pole Mounted Sign		
Sign Type	Sign Detail & Installation	Quantity	Rate	Cost
Marquee Pole	Labor- Digging and Footing	24.00	\$74.00	\$1,776.00
Marquee Pole	Labor-Setting Rebar	24.00	\$74.00	\$1,776.00
Marquee Pole	Labor-Formwork and Concrete Pouring	16.00	\$74.00	\$1,184.00
Marquee Pole	Labor-Setting Pole	16.00	\$74.00	\$1,184.00
Marquee LED Sign	Labor-Installing LED Sign	32.00	\$74.00	\$2,368.00
Marquee LED Sign	Labor-Electrical Hookup	8.00	\$74.00	\$592.00
Marquee Monument	Labor-Already in Original Quote-Credit	70.00	\$ (74.00)	\$ (5,180.00)
Marquee Pole	Material-Formwork	1.00	\$650.00	\$650.00
Marquee Pole	Auger Rental	1.00	\$450.00	\$450.00
Marquee Pole	Crane Rental (Day 1) Digging, Footing, Setting Rebar, Formwork, Pouring	1.00	\$2,400.00	\$2,400.00
Marquee Pole and LED Sign	Crane Rental (Day 2) Setting Pole, Lifting and Installation of LED Sign	1.00	\$2,400.00	\$2,400.00
Marquee Pole	HSS Steel Pole 6x6x3/8" 22.5' Long, Includes Fabrication, Sign Fittings, 18x18 Aluminum Pole Cover	1.00	\$3,650.00	\$3,650.00
Marquee Footing	Concrete- Less Concrete used for Footing then Monument Base- Credit Applied	1.00	\$ (1,500.00)	\$ (1,500.00)
Marquee Footing	Additional Rebar	1.00	\$1,100.00	\$1,100.00
Marquee Pole and LED Sign	Misc. Hardware	1.00	\$650.00	\$650.00
	SUBTOTALS			\$13,500.00

*Subtotal: \$13,500.00

15% Markup: \$2,025.00

Combined Subtotal + Markup: \$15,525.00

Bond 3% (of *Subtotal): \$465.75

GRAND TOTAL: \$15,525.00

(Including GC & First Tier Sub cost)

PROGRAM MANAGER



DATE

January 25, 2019

SUB. CON - NAME/TITLE

DATE



SWINERTON

January 28, 2019

Oxnard School District
1051 South A Street
Oxnard, CA, 93030

Attn: Mario Mera

Subject: Swinerton Builders Job 16055106 - Lemonwood K-8 School LLB
PCI No. 0461

Dear Mr. Mera,

We request a Change Order to our contract for the following:

Contract documents indicate an 8' lighting fixture illuminating a 10'10" sign. RFI 374 answer directs the installation of an additional 4' fixture

Phase	Category	Description	Subcontractor	Quote
260010	71140	RFI 374 add Signage lighting fixture at Administration Building	TAFT ELECTRIC COMPANY	1,413.00
			Subtotal	1,413.00
007480	71160	Subguard	1.15%	16.25
007410	71160	Builders Risk	0.6%	8.58
007420	71160	General Insurance	1.15%	16.44
007510	71160	P&P Bond	1%	14.13
991000	79999	Change Order Fee	5%	72.71
			Markup Subtotal	128.11
			PCI Total	1,541.11

TOTAL AMOUNT OF THIS CHANGE ORDER REQUEST: **1,541.11.**

Please NOTE:

- » The incorporation of this revision in to the contractual scope of work may have an impact on our schedule, which is yet to be finalized. Once determined, the job schedule will be adjusted accordingly to show the effect of this revision on the final project completion date.
- » The terms (cost and schedule impact) of this change order request are subject to review and a requote if not accepted within days of its issuance.
- » This request does not include additional cost or delay due to late approval.

 X We **HAVE NOT** proceeded with this revised work per your instructions. Please issue a change order.

Upon acceptance of this change order request, a formal change order will be issued. Acceptance also



SWINERTON

acknowledges that Swinerton Builders is directed to proceed with the above change in scope.

If you have any questions or comments pertaining to this matter, please contact the undersigned.

Sincerely,
Swinerton Builders

Date: 1/28/2019

Quotation accepted by:
Oxnard School District

By: _____

Date: _____

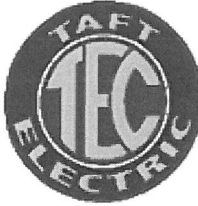

Taft Electric Company

1694 Eastman Avenue

Ventura, CA 93003

(805)642-0121

Contractor License # 772245

Change Order Request

Detailed, Grouped by Each Number

2241 Lemonwood
2200 Carnegie Court
Oxnard, CA 93033

Project # 2241
Tel: Fax:

Taft Electric Company

Change Order Request: 101 **Date:**

To: Bill Gray Swinerton Builders 865 S. Figueroa Street Los Angeles, CA 90017	From: Matt Gobuty Taft Electric Company P.O. Box 3416 Ventura, CA 93006
---	---

Description	Category	Status
Type 13 Extended		Submitted

Reference	Required By	Days Req	Amt Req
TEC RFI 077		0	1,413

Notes

We are submitting the above cost to provide rough in and installation for an additional 4' length of Type 13 Fixture for the Administration Sign. (See TEC RFI 075 attached)

Includes:
 Type 13 Additional 4' length
 Type 13 Brackets
 Roughin + installation

This quote is valid for 30 calendar days from the above date. We reserve our right to re-quote this proposal should the approval take longer than 30 days.

Attached is the back up for your review. Please call should you have any questions.

Matt Gobuty
Project Manager
(805)654-7994

PCO No	Date	Reference	Amt Prop	Days Req	Category	Reason
		Description	Notes			

Approved By:

Signature _____
 Name _____ Date _____

Job ID: 2241 LEMONWOOD COR
Project: 2241 Lemonwood COR



Takeoff

Vendor: TAFT

Labor Level: LABOR 1

4 Oct 2018 15:53:13

Region: COR 101 TYPE 13

Item #	Qty	U/M	Q/M	Size	Description	Material Unit	Material Result	Labor Unit	Labor Result
150185	1.00	EA	M	1-1/2"D 15-5-CI	4" OCTAGON BAR-HGR	12.8900	12.89	0.7200	0.72
120	1.00		M		4' LINEAR LED FIXTURE	0.0000	0.00	0.8500	0.85
121	1.00		M		LINEAR FIXTURE BRACKET	0.0000	0.00	0.2500	0.25
Phase Totals:						12.89	12.89	1.82	1.82
Job Totals:						12.89	12.89	1.82	1.82

Taft Electric Company

1694 Eastman Avenue
 Ventura, CA 93003

Phone: 805-642-0121
Web: www.taftelectric.com

CED ROYAL INDUSTRIAL SOLUTIONS
 1807 PALMA DRIVE
 VENTURA CA 93003
 TEL: 805 642-0361 FAX: 805 654-0569

CONTACT: KARRIE

QUOTE FOR: TAFT ELECTRIC

ACCT #: 18-32223 TAFT-LEMONWOOD ELEMENTARY S

LEMONWOOD ELEMENTARY SCHOOL
 1694 EASTMAN AVENUE
 VENTURA, CA 93003

QUOTATION			PAGE 001 OF 001
QUOTE # 1089782	DATE 08/30/18	REV # 002	REV DATE 08/30/18
QUOTE EXPIRES 09/29/2018		PREPARED BY KT	
SLS 0184		INSL 9007	
FOB SHIPPING POINT		FREIGHT PREPAY & CHARGE	

CUS PO #:

JOB NAME:
 LEMONWOOD

LN	QTY	MFR	CATALOG #	DESCRIPTION	PRICE	UOM	EXT AMT
01	3	ECOS	L50-E-48-10-35-80-	MULT-70X70	815.00	E	2,445.00
02	4	ECOS	WMA-L-CA-12		65.00	E	260.00
03	2	ECOS	WMA-L-JNR		12.50	E	25.00
04	1	ECOS	WMA-L-END		18.75	E	18.75
05	1	ECOS	CBL-3P-L-UNV-10		25.00	E	25.00
06	*						
07	*		2-3 WEEK LEAD TIME				
08	*		TYPE 13				
09	*						
10	*		PLUS FRT - ESTIMATE @ \$ 175.00				
11	*		PLUS TAX				

TOTAL: 2,773.75

PLEASE NOTE: THIS IS NOT AN OFFER TO CONTRACT, BUT MERELY A QUOTATION OF CURRENT PRICES FOR YOUR
 CONVENIENCE AND INFORMATION. ORDERS BASED ON THIS QUOTATION ARE SUBJECT TO YOUR ACCEPTANCE OF
 THE TERMS AND CONDITIONS LOCATED AT SALES.OUR-TERMS.COM, WHICH WE MAY CHANGE FROM TIME TO TIME
 WITHOUT PRIOR NOTICE. WE MAKE NO REPRESENTATION WITH RESPECT TO COMPLIANCE WITH JOB
 SPECIFICATIONS.



Swinerton Builders
 17731 Mitchell North Suite 200
 Irvine CA 92614

Request For Information

00374

Printed On: 01/28/2019
 Page 1 of 1

SWINERTON

Subject: Administration Sign Dimension

Date: 09/24/2018

Project: Lemonwood K-8 School LLB

Job: 16055106

Address: 2200 Carnegie Court
 Oxnard CA 93033

Required: 09/28/2018

Phone: 949-355-6822

Fax:

Est. Cost Impact : \$

Est. Days Impact:

To: Tom Bardwell
 SVA ARCHITECTS, INC.

From: Swinerton Builders

Nalani Scanlon

Co-Author: TAFT ELECTRIC COMPANY

Contact: Matt Gobuty

Co-Author RFI Number: TAFT-00074

Reference:

RFI Type: ELECTRICAL Electrical

RFI Priority:

Schedule / Activit

Document Refere

Spec Section:

Posted:

Request

The ADMINISTRATION sign is shown on the electrical and architectural drawings as 8' in length. The shop drawing (attached) shows a 10'10" long sign. We recommend adding (1) 4' length to the Type 13 sign light to ensure the sign is fully illuminated. Please advise

Suggestion

Answer **Accept Suggestion**

No exception taken to contractors proposed solution. Provide (1) 48" Type 13 fixture added to the proposed 8' length for a total length of 12'. Fixture shall be centered on proposed sign.

Nick Bruno
 tk1sc

Answered By: SVA ARCHITECTS, INC.

Signed: _____
 Tom Bardwell

Date: 09/24/2018

Distribution:

Contact	Company	Contact	Company
Paul Vernier	Oxnard School District	Bill Gray	Swinerton Builders
Christopher Barbato	Swinerton Builders		

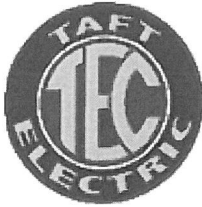

Taft Electric Company

1694 Eastman Avenue
Ventura, CA 93003
(805)642-0121
Contractor License # 772245

TEC RFI 077

Detailed, RFIs without Routing Information Grouped by RFI Number

2241 Lemonwood
2200 Carnegie Court
Oxnard, CA 93033

Project # 2241
Tel: Fax:

Taft Electric Company

RFI #: 077 **Date Created: 9/20/2018**

RFI Issued To:	Contact Name	Author Company	Authored By
Swinerton Builders 865 S. Figueroa Street Los Angeles, CA 90017	Nalani Scanlon	Taft Electric Company P.O. Box 3416 Ventura, CA 93006	Matt Gobuty

RFI Answered By: **Owner RFI Number**

Subject	Discipline	Category
Administration Sign Dimensions	Electrical	

Cost Impact	Amount	Sched Impact	Days	Dwg Impact
Not Sure		Not Sure		Not Sure

Cost Impact Comments	Sched Impact Comments	Dwg Impact Comments

Cc: Company Name	Contact Name	Copies	Notes

Question **Date Required: 9/27/2018**

The ADMINISTRATION sign is shown on the electrical and architectural drawings as 8' in length. The shop drawing (attached) shows a 10'10" long sign. We recommend adding (1) 4' length to the Type 13 sign light to ensure the sign is fully illuminated.
Please advise

Suggestion

Answer **Date Answered:**

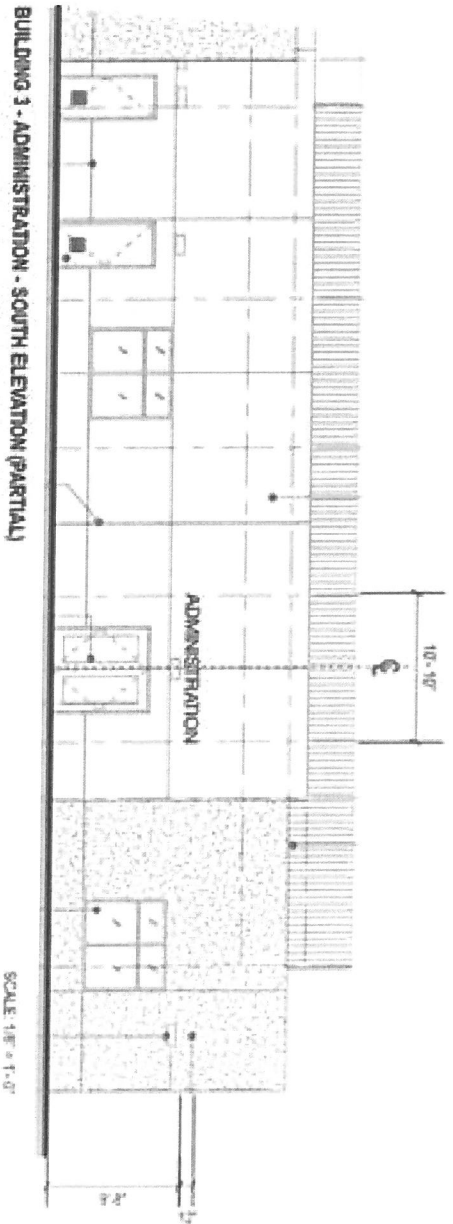

BUILDING 3 - ADMINISTRATION - SOUTH ELEVATION (PARTIAL)

SCALE: 1/8" = 1'-0"

10'-10"

ADMINISTRATION

3

1 1/2" CAST ALUMINUM LETTERS

EXTERIOR WALL MOUNTED SIGN

SCALE: 3/4" = 1'-0"

1 1/2" THICK CAST ALUMINUM LETTERS
 FONT TYPE - HELVETICA - REGULAR (ST - HELVETICA T)
 FINISH - T.B.D.
 FLUSH MOUNTED (SEE PAGE 32 OF 41 FOR MOUNTING DETAILS)

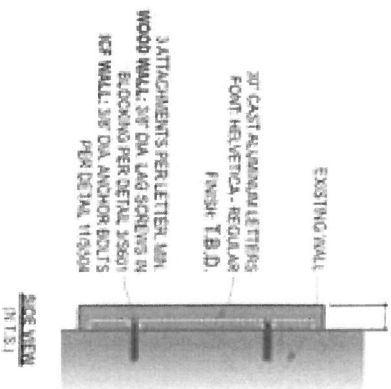

THESE DRAWINGS HAVE BEEN PREPARED BY THE ARCHITECTS AND ENGINEERS ASSOCIATED WITH THE FIRM AND THE ARCHITECTS AND ENGINEERS ASSOCIATED WITH THE FIRM ARE NOT RESPONSIBLE FOR ANY ERRORS OR OMISSIONS IN THESE DRAWINGS. THE ARCHITECTS AND ENGINEERS ASSOCIATED WITH THE FIRM ARE NOT RESPONSIBLE FOR ANY ERRORS OR OMISSIONS IN THESE DRAWINGS. THE ARCHITECTS AND ENGINEERS ASSOCIATED WITH THE FIRM ARE NOT RESPONSIBLE FOR ANY ERRORS OR OMISSIONS IN THESE DRAWINGS.

PLEASE VERIFY ALL INFORMATION IS CORRECT
 MARK ANY CHANGES THAT ARE REQUIRED
 PRIOR TO FABRICATION

PROJECT ADDRESS
 2200 CARRIEGIE COURT
 OXNARD, CA 93033

Lemonwood K-8 School		(6/28/2017)		NO. OF SHEETS	PROJECT NO.
SHEWALTER BUILDERS				5	1146
				DATE	31/41

Matt Gobuty

From: CMiC I/O <cmicionewprod@swinerton.com>
Sent: Thursday, September 27, 2018 10:48 AM
To: Matt Gobuty
Subject: 16055106MG RFI TAFT-00074 Administration Sign Dimension
Attachments: RFI 077 ADMINISTRATION Sign.pdf

RFI TAFT-00074

From	Matt Gobuty
To	Matt Gobuty
CC	
Project	Lemonwood K-8 School LLB
Subject	Administration Sign Dimension

Author: Nalani Scanlon

Date: 2018-09-24 12:55 PM

Forwarded by Nalani Scanlon to Tom Bardwell as 00374

Subject: Administration Sign Dimension
Date Required: 2018-09-20
Cost Impact: Yes
Cost Amount:

Question: The ADMINISTRATION sign is shown on the electrical and architectural drawings as 8' in length. The shop drawing (attached) shows a 10'10" long sign. We recommend adding (1) 4' length to the Type 13 sign light to ensure the sign is fully illuminated. Please advise

Modified question:

The ADMINISTRATION sign is shown on the electrical and architectural drawings as 8' in length. The shop drawing (attached) shows a 10'10" long sign. We recommend adding (1) 4' length to the Type 13 sign light to ensure the sign is fully illuminated. Please advise

Suggestion:

Answer: No exception taken to contractors proposed solution. Provide (1) 48" Type 13 fixture added to the proposed 8' length for a total length of 12'. Fixture shall be centered on proposed sign.

Nick Bruno
tk1sc

[Click here](#) to access this RFI on-line, or simply reply to this email with your comments and any required attachments.

Note: Please ensure that you leave "**16055106MG RFI TAFT-00074**" in the subject line of all emails you send related to this RFI. Replies must be **above** the original message. Attachments will also be accepted.



SWINERTON

January 28, 2019

Oxnard School District
1051 South A Street
Oxnard, CA, 93030

Attn: Mario Mera

Subject: Swinerton Builders Job 16055106 - Lemonwood K-8 School LLB
PCI No. 0462 Add electrical circuit to HVAC BS controller

Dear Mr. Mera,

We request a Change Order to our contract for the following:

While installing new HVAC system to the existing ECDC Bldg., it was discovered that the BS Controller required a separate electrical circuit. This requirement was not indicated on the mechanical or electrical drawings.

Phase	Category	Description	Subcontractor	Quote
260010	71140	Added electrical to ECDC HVAC BS controller	TAFT ELECTRIC COMPANY	707.00
			Subtotal	707.00
007480	71160	Subguard	1.15%	8.13
007410	71160	Builders Risk	0.6%	4.29
007420	71160	General Insurance	1.15%	8.23
007510	71160	P&P Bond	1%	7.07
991000	79999	Change Order Fee	5%	36.38
			Markup Subtotal	64.10
			PCI Total	771.10

TOTAL AMOUNT OF THIS CHANGE ORDER REQUEST: **771.10**.

Please NOTE:

- » The incorporation of this revision in to the contractual scope of work may have an impact on our schedule, which is yet to be finalized. Once determined, the job schedule will be adjusted accordingly to show the effect of this revision on the final project completion date.
- » The terms (cost and schedule impact) of this change order request are subject to review and a requote if not accepted within days of its issuance.
- » This request does not include additional cost or delay due to late approval.

We **HAVE NOT** proceeded with this revised work per your instructions. Please issue a change order.

Upon acceptance of this change order request, a formal change order will be issued. Acceptance also



SWINERTON

acknowledges that Swinerton Builders is directed to proceed with the above change in scope.

If you have any questions or comments pertaining to this matter, please contact the undersigned.

Sincerely,
Swinerton Builders

Quotation accepted by:
Oxnard School District

Date: _____

By: _____

Date: _____

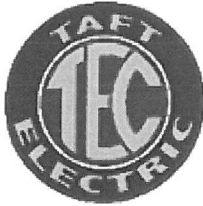

Taft Electric Company

1694 Eastman Avenue
Ventura, CA 93003
(805)642-0121
Contractor License # 772245

Change Order Request

Detailed, Grouped by Each Number

2241 Lemonwood
2200 Carnegie Court
Oxnard, CA 93033

Project # 2241
Tel: Fax:

Taft Electric Company

Change Order Request: 097

Date: 8/14/2018

To: Bill Gray
Swinerton Builders
865 S. Figueroa Street
Los Angeles, CA 90017

From: Matt Gobuty
Taft Electric Company
P.O. Box 3416
Ventura, CA 93006

Description	Category	Status
Bldg 500 HVAC Extras		Submitted

Reference	Required By	Days Req	Amt Req
	8/21/2018	0	707

Notes

Install an additional 20A circuit to feed HVAC BS controller circuit in building 500 on T&M

Attached is the back up for your review. Please call should you have any questions.

Matt Gobuty
Project Manager
(805)654-7994

PCO No	Date	Reference	Amt Prop	Days Req	Category	Reason
		Description	Notes			

Approved By:

Signature _____

Name _____ **Date** _____

Job ID: 2241 LEMONWOOD COR
Project: 2241 Lemonwood COR



Takeoff

Vendor: TAFE

Labor Level: LABOR 1

14 Aug 2018 13:12:12

Region: BASE BID

Item #	Qty	U/M	Q/M	Size	Description	Material Unit	Material Result
TITLE	1.00		M		GFI WP	0.0000	0.00
140027	1.00	EA	M	20A	DX GFCI REC WEATHER RESIST	13.6860	13.69
TITLE	1.00		M		BELL 1G	0.0000	0.00
150389	1.00	EA	M	2" DEEP 16-5-CI	1G ALUM WP (BELL) BOX W/ 4 X 3/4" HUBS	9.2752	9.28
140634	1.00	EA	M	VERT	1G WP GFCI PLATE -IN USE	22.9361	22.94
TITLE	1.00		M	1/2	LIQUIDTITE COND WHIP	0.0000	0.00
50073	5.00	FT	M	1/2	LIQUIDTITE CONDUIT	1.0485	5.24
50095	2.00	EA	M	1/2	LIQUIDTITE STRAIGHT CONNECTOR	2.0356	4.07
160019	2.00	EA	M	1/2	MINERALLAC HANGERS W/BOLT	0.4525	0.91
70033	450.00	FT	M	12	THHN/THWN CU (STR)	0.1234	55.53
Phase Totals:						111.65	111.65
Job Totals:						111.65	111.65

Taft Electric Company

1694 Eastman Avenue
 Ventura, CA 93003

Phone: 805-642-0121
 Web: www.taftelectric.com



SWINERTON

February 5, 2019

Oxnard School District
1051 South A Street
Oxnard, CA, 93030

Attn: Mario Mera

Subject: Swinerton Builders Job 16055106 - Lemonwood K-8 School LLB
PCI No. 0464 Remove and replace existing City sidewalk on San Mateo Place

Dear Mr. Mera,

We request a Change Order to our contract for the following:

Remove city sidewalk damaged by existing tree roots. Existing sidewalk was unsafe for public use.

Phase	Category	Description	Subcontractor	Quote
321313	71140	Remove and replaced city sidewalk on San Mateo Place	SANTA CLARITA CONCRETE	6,641.25
			Subtotal	6,641.25
007480	71160	Subguard	1.15%	76.37
007410	71160	Builders Risk	0.6%	40.31
007420	71160	General Insurance	1.15%	77.25
007510	71160	P&P Bond	1%	66.41
991000	79999	Change Order Fee	5%	341.76
			Markup Subtotal	602.10
			PCI Total	7,243.35

TOTAL AMOUNT OF THIS CHANGE ORDER REQUEST: **7,243.35.**

Please NOTE:

- » The incorporation of this revision in to the contractual scope of work may have an impact on our schedule, which is yet to be finalized. Once determined, the job schedule will be adjusted accordingly to show the effect of this revision on the final project completion date..
- » The terms (cost and schedule impact) of this change order request are subject to review and a requote if not accepted within days of its issuance.
- » This request does not include additional cost or delay due to late approval.

 X We **HAVE** proceeded with this revised work per your instructions. Please issue a change order.



SWINERTON

Upon acceptance of this change order request, a formal change order will be issued. Acceptance also acknowledges that Swinerton Builders has proceeded with the above change in scope.

If you have any questions or comments pertaining to this matter, please contact the undersigned.

Sincerely,
Swinerton Builders

[Handwritten signature]
Date: 2/05/2019

Quotation accepted by:
Oxnard School District

By: _____

Date: _____



16164 Sierra Highway
 Santa Clarita, CA 91390
 Phone 661.252.2012
 Fax 661.298.4585
 CA License No. 381605

CHANGE ORDER REQUEST

COR	SCC-031
P&O	15.00%
SUB P&O	5.00%
BOND	1.00%
REVISION	Original submission

PROJECT	Lemonwood
OWNER/REP	Swinerton Construction
ATTN	Bill Gray
DATE	2/4/19
REFERENCE	As Directed

NARRATIVE FOR CHANGE ORDER REQUEST

Provide labor, equipment and materials to perform additional scope as requested by Swinerton Builders: grade, form and pour new concrete as directed

REF	DESC	LOC	DATE	CATEGORY	TYPE	R/OT	QTY	UNIT	RATE	TOTAL
AWA-10570	P/F concrete	site concrete	1/10/19	Unit pricing	paving	R	305	Sf	\$15.00	\$4,575.00
AWA-10570	P/F concrete	site concrete	1/10/19	Unit pricing	grading	R	480	305	\$2.50	\$1,200.00

EXCLUSIONS/QUALIFICATIONS

Price assumes work to be done concurrently with other work.
 Separate mobilization will require additional costs.
 Bond is not included in this COR
 All work done as directed by Swinerton Builders
 SCC assumes no responsibility for damage to adjacent surfaces/landscaping for any reason.

EXTENSION OF CONTRACT DURATION-->

1 Day

SUB-TOTAL	\$5,775.00
P&O	\$866.25
TOTAL FOR THIS COR	\$6,641.25

Replace City sidewalk where tree root
 heaved sidewalk



(661) 252-2012
Lic. No. 381605
16164 Sierra Hwy.
Santa Clarita, CA 91390

AUTHORIZATION 10570

ADDITIONAL WORK AUTHORIZATION

DATE: 1-10-19

Through 1-11-19

CUSTOMERS NAME Swinerton

JOB NAME Lemonwood

STREET

STREET

CITY STATE

CITY

JOB # TRACT #

You are hereby authorized to perform the following specifically described additional work:

Extra to contract grade and form work
City sidewalk Total of 305.5F

ADDITIONAL CHARGE FOR ABOVE WORK IS \$

TERMS ARE NET - 10TH PROX.

The above work is an extra to the original contract for the above referenced job:

AUTHORIZING SIGNATURE (Customer signs here)

DATE: 1/10/19

We hereby agree to furnish material and labor - complete in accordance with the above specifications, at above stated price.

AUTHORIZING SIGNATURE (Contractor signs here)

DATE:



SWINERTON

February 6, 2019

Oxnard School District
1051 South A Street
Oxnard, CA, 93030

Attn: Mario Mera

Subject: Swinerton Builders Job 16055106 - Lemonwood K-8 School LLB
PCI No. 0467 RFI 0393 Revise concrete curb at new playground area located north of the Kindergarten Building

Dear Mr. Mera,

We request a Change Order to our contract for the following:

Revise concrete curb detail from a thickened concrete edge detail to a curb that can be independent

Phase	Category	Description	Subcontractor	Quote
321313	71140	RFI 0392 Revise concrete curb around new playground area north of Kindergarten Building	SANTA CLARITA CONCRETE	4,830.00
			Subtotal	4,830.00
007480	71160	Subguard	1.15%	55.55
007410	71160	Builders Risk	0.6%	29.31
007420	71160	General Insurance	1.15%	56.18
007510	71160	P&P Bond	1%	48.30
991000	79999	Change Order Fee	5%	248.55
			Markup Subtotal	437.89
			PCI Total	5,267.89

TOTAL AMOUNT OF THIS CHANGE ORDER REQUEST: **5,267.89.**

Please NOTE:

- » The incorporation of this revision in to the contractual scope of work may have an impact on our schedule, which is yet to be finalized. Once determined, the job schedule will be adjusted accordingly to show the effect of this revision on the final project completion date..
- » The terms (cost and schedule impact) of this change order request are subject to review and a requote if not accepted within days of its issuance.
- » This request does not include additional cost or delay due to late approval.

We **HAVE** proceeded with this revised work per your instructions. Please issue a change order.



SWINERTON

Upon acceptance of this change order request, a formal change order will be issued. Acceptance also acknowledges that Swinerton Builders has proceeded with the above change in scope.

If you have any questions or comments pertaining to this matter, please contact the undersigned.

Sincerely,
Swinerton Builders

2/06/2019

Date: _____

Quotation accepted by:
Oxnard School District

By: _____

Date: _____



16164 Sierra Highway
 Santa Clarita, CA 91390
 Phone 661.252.2012
 Fax 661.298.4585
 CA License No. 381605

CHANGE ORDER REQUEST

COR	SCC-032
P&O	15.00%
SUB P&O	5.00%
BOND	1.00%
REVISION	Original submission

PROJECT	Lemonwood
OWNER/REP	Swinerton Construction
ATTN	Bill Gray
DATE	2/4/19
REFERENCE	As Directed

NARRATIVE FOR CHANGE ORDER REQUEST

Provide labor, equipment and materials to perform additional scope as requested by Swinerton Builders: form and place concrete at basketball area

REF	DESC	LOC	DATE	CATEGORY	TYPE	R/OT	QTY	UNIT	RATE	TOTAL
AWA-10573	PF curb 6x14	playground	1/25/19	Unit pricing	curb 6x14	R	210	Lf	\$35.00	\$7,350.00
AWA-10573	PF curb 6x14	playground	1/25/19	Unit pricing	Paving	R	120	Lf	\$15.00	\$1,800.00
AWA-10573	Credit	playground	1/25/19	Credit back	Thick Edge	R	210	Lf	-\$15.00	-\$3,150.00

EXCLUSIONS/QUALIFICATIONS

Price assumes work to be done concurrently with other work.
 Separate mobilization will require additional costs.
 Bond is not included in this COR
 All work done as directed by Swinerton Builders
 SCC assumes no responsibility for damage to adjacent surfaces/landscaping for any reason.

EXTENSION OF CONTRACT DURATION-->

1 Day

SUB-TOTAL	\$6,000.00
P&O	\$900.00
TOTAL FOR THIS COR	\$6,900.00

Added 6x14 Curb $\$4700 + \$630 = \$5330$

Paving $\$2070$



Swinerton Builders
 17731 Mitchell North Suite 200
 Irvine CA 92614

Request For Information

00392

Printed On: 02/06/2019

Page 1 of 2

SWINERTON

Subject: Perimeter concrete band at new playground north of new Kindergarten Building **Date:** 01/16/2019
Project: Lemonwood K-8 School LLB **Job:** 16055106
Address: 2200 Carnegie Court **Required:** 01/16/2019
 Oxnard CA 93033
Phone: 949-355-6822 **Fax:** **Est. Cost Impact :** \$
To: Tom Bardwell **Est. Days Impact:**
 SVA ARCHITECTS, INC.
From: Swinerton Builders Bill Gray

Co-Author: **Contact:** **Co-Author RFI Number:**

Reference:

RFI Type:	Civil / Site	Civil / Site Work	RFI Priority:	High	High
Schedule / Activit			Document Refere		
Spec Section:			Posted:		

Request

Civil drawing C-3 indicates a mow curb at the north side of the new playground area, note 21, detail M/C-8 which is 6"x14". The landscape drawings L-1.2 note 2 indicate a thickened edge around perimeter of playground area, J/L-1.3 which is a 12" wide x 4" thick band. This all asphalt paving around the playground. Please provide proper detail for this area/condition

Suggestion

Install mow strip per M/C-8

Answer **Accept Suggestion**

Refer to attached sketch for proposed solution.
 SVA 1/17/19

Answered By: SVA ARCHITECTS, INC.

Signed: _____
 Tom Bardwell

Date: 01/17/2019

Distribution:

Contact	Company	Contact	Company
Paul Vernier	Oxnard School District	Mark Trail	Swinerton Builders

Contact

Nalani Scanlon

Company

Swinerton Builders

Contact

Curtis Marzinzik

Company

SANTA CLARITA CONCRE

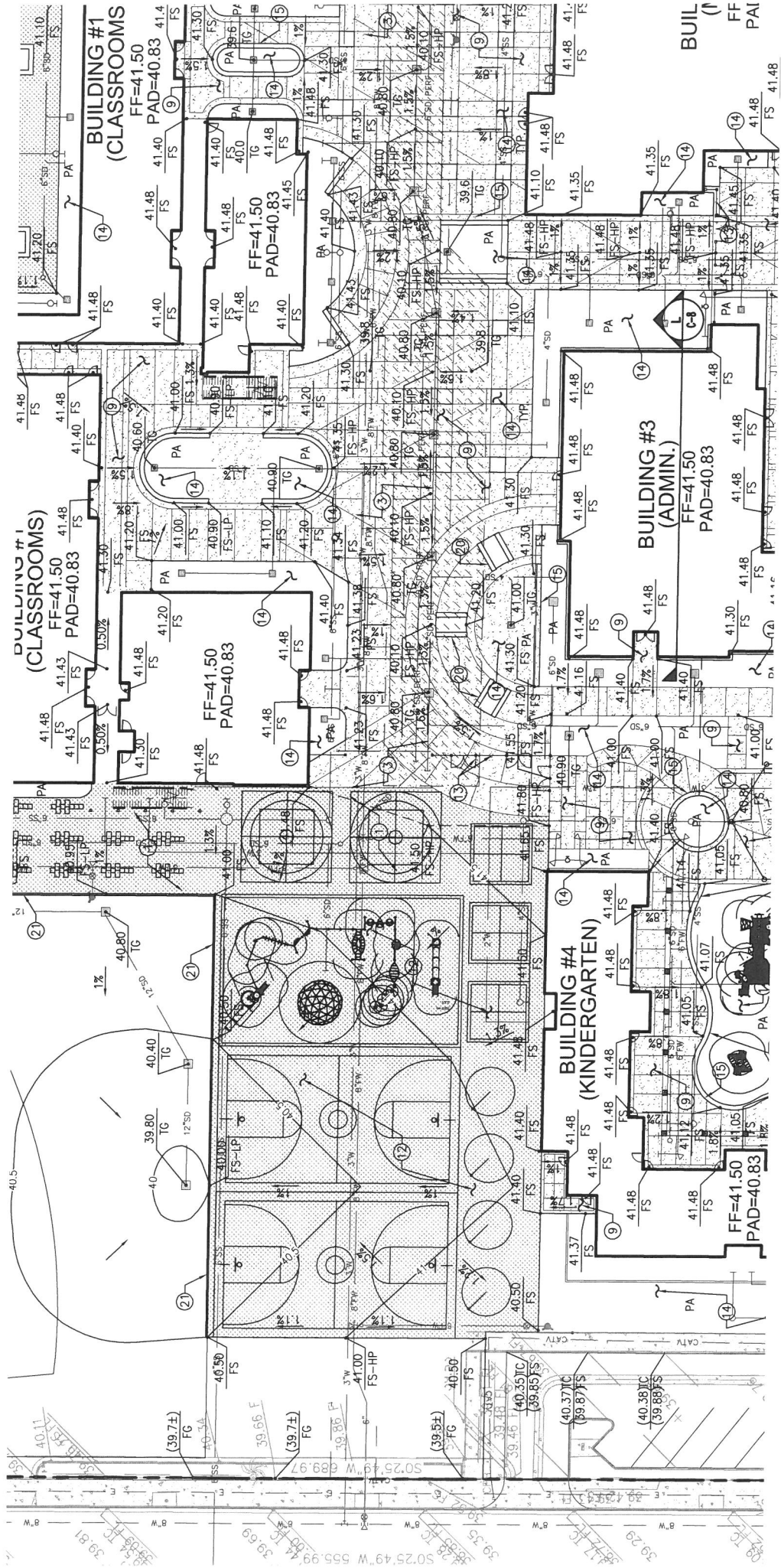

BUILD (↑)
FF
PAI



SWINERTON

February 15, 2019

Oxnard School District
1051 South A Street
Oxnard, CA, 93030

Attn: Mario Mera

Subject: Swinerton Builders Job 16055106 - Lemonwood K-8 School LLB
PCI No. 0471 Axiom soffit in Administartion Building Media Center entry

Dear Mr. Mera,

We request a Change Order to our contract for the following:

Create soffit in suspended acoustical ceiling at the entry to the Media Center using Armstrong Axiom panels

Phase	Category	Description	Subcontractor	Quote
095100	71140	Create soffit in suspended acoustical ceiling at the entry to the Media Center using Armstrong Axiom panels	HAMILTON CEILING SYSTEMS INC.	1,000.00
			Subtotal	1,000.00
007480	71160	Subguard	1.15%	11.50
007410	71160	Builders Risk	0.6%	6.07
007420	71160	General Insurance	1.15%	11.63
007510	71160	P&P Bond	1%	10.00
991000	79999	Change Order Fee	5%	51.46
			Markup Subtotal	90.66
			PCI Total	1,090.66

TOTAL AMOUNT OF THIS CHANGE ORDER REQUEST: **1,090.66.**

Please NOTE:

- » The incorporation of this revision in to the contractual scope of work may have an impact on our schedule, which is yet to be finalized. Once determined, the job schedule will be adjusted accordingly to show the effect of this revision on the final project completion date..
- » The terms (cost and schedule impact) of this change order request are subject to review and a requote if not accepted within days of its issuance.
- » This request does not include additional cost or delay due to late approval.

 X We **HAVE** proceeded with this revised work per your instructions. Please issue a change order.



SWINERTON

Upon acceptance of this change order request, a formal change order will be issued. Acceptance also acknowledges that Swinerton Builders has proceeded with the above change in scope.

If you have any questions or comments pertaining to this matter, please contact the undersigned.

Sincerely,
Swinerton Builders

Date: 2/15/2015

Quotation accepted by:
Oxnard School District

By: _____

Date: _____

HAMILTON CEILING SYSTEMS, INC.

572 E. Caroline Street Unit #8
San Bernardino, CA. 92408
Phone: (951) 276-1843
Fax: (951) 276-1846
License # 787546

January 18, 2019

CHANGE ORDER REQUEST

Lemonwood Elementary School
Oxnard, Ca.

PROPOSED CHANGE AMOUNT: \$1,000.00

DESCRIPTION OF WORK TO BE PERFORMED

Install soffit at entry area of Admin. 2 pcs 12" Armstrong Axiom

- **Material:** \$550.34
- **Labor:** \$319.72 (4 hrs. x \$79.93)
- **Subtotal** \$870.06
- **P&O** \$130.51
- **Total** \$1,000.57

Please call if you have any questions.

Submitted by:
John Harrington

Before work commences and materials are ordered this change order must be accepted in writing and an original Change Order must be issued on General Contractor standard form to proceed.

Accepted by: _____ Date: _____

Please Print Name: _____

HAMILTON CEILING SYSTEMS, INC.

TIME & MATERIAL

Project Name: Lemonwood K-8
Project Location: 2200 Carnegie Court. Oxnard, CA
General Contractor: Swinerton Builders

DESCRIPTION OF WORK TO BE PERFORMED

LABOR:

Journeyman Hours: 4 hours
Apprentice Hours: _____

MATERIAL:

~~Main Runners:~~ 2 Pcs of 12" Axiom -10'-L
Cross Tees: _____
Wall Angle: _____
Wires: _____
Ceiling Tile & Type: _____

EQUIPMENT:

ADDITIONAL INFO:

Install soffit at entry area Admin Bldg.

Hamilton Ceiling Systems: (Print & Sign) Jose Frisby

Accepted by: (Print & Sign) Mark Trail MARK TRAIL

Date: Jan-16-19



SWINERTON

February 21, 2019

Oxnard School District
1051 South A Street
Oxnard, CA, 93030

Attn: Mario Mera

Subject: Swinerton Builders Job 16055106 - Lemonwood K-8 School LLB
PCI No. 0473 Bali Construction delay cost-DTSC NFA delay Ph I

Dear Mr. Mera,

We request a Change Order to our contract for the following:

Due to late DTSC NFA letter, the underground utility subcontractor could not complete their work as originally schedule in the approved baseline schedule. Subcontractor was forced to complete work after a labor cost increase

Phase	Category	Description	Subcontractor	Quote
330200	71140	Due to late DTSC NFA letter, the underground utility subcontractor could not complete their work as originally schedule in the approved baseline schedule. Subcontractor was forced to complete work after a labor cost increase	BALI CONSTRUCTION INC.	2,144.00
			Subtotal	2,144.00
007480	71160	Subguard	1.15%	24.66
007410	71160	Builders Risk	0.6%	13.01
007420	71160	General Insurance	1.15%	24.94
007510	71160	P&P Bond	1%	21.44
991000	79999	Change Order Fee	5%	110.33
			Markup Subtotal	194.38
			PCI Total	2,338.38

TOTAL AMOUNT OF THIS CHANGE ORDER REQUEST: **2,338.38.**

Please NOTE:

- » The incorporation of this revision in to the contractual scope of work may have an impact on our schedule, which is yet to be finalized. Once determined, the job schedule will be adjusted accordingly to show the effect of this revision on the final project completion date..
- » The terms (cost and schedule impact) of this change order request are subject to review and a requote if not accepted within days of its issuance.



SWINERTON

» This request does not include additional cost or delay due to late approval.

X We **HAVE** proceeded with this revised work per your instructions. Please issue a change order.

Upon acceptance of this change order request, a formal change order will be issued. Acceptance also acknowledges that Swinerton Builders has proceeded with the above change in scope.

If you have any questions or comments pertaining to this matter, please contact the undersigned.

Sincerely,
Swinerton Builders

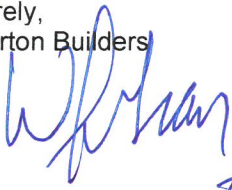

2/21/2019

Date: _____

Quotation accepted by:
Oxnard School District

By: _____

Date: _____



SINCE 1987

9852 E. Joe Vargas Way
So. El Monte CA, 91733
Phone: **626.442.8003**
www.baliconstruction.com

LIC. 524540

June 14, 2016

Swinerton Builders
17731 Mitchell North #200
Irvine, CA 92614

Attention: Scott Augustine – Project Manager

Reference: Lemonwood K-8 School
2200 Carnegie Court
Oxnard, CA 93033
GC Job No.: 16055106
Bali Job No.: 16-043

Subject: Change Order Request No. 2
Schedule Delay – Labor Cost Increases

Gentlemen,

We hereby submit our Change Order Request No. 2 for the labor cost increases due to the schedule delay for the referenced project. Attached with this letter is a detailed breakdown of the additional cost associated with this work. The following is a summary.

Schedule Delay – Labor Cost Increases	\$2,144.00
--	-------------------

Please issue a Change Order.

If you have any questions, please call us. Thank you.

Respectfully yours,
Bali Construction, Inc.

Kevin Delate

Bali Construction, Inc.
Change Order Request No. 2

16-043 Lemonwood K-8 School
 Schedule Delay - Labor Rates Increases at 7/1/16
 Nineteen (19) Crew Days Delay

Description	Units	Quantity	Unit Price	Extension
Materials				
Subtotal Materials				\$0.00
Sales Tax	9.00%			\$0.00
Labor				
Straight Time to 7/1/16				
Foreman	hr	-152	\$86.51	-\$13,149.52
Operator (2 Men)	hr	-304	\$79.41	-\$24,140.64
Laborer (3 Men)	hr	-456	\$61.90	-\$28,226.40
Carpenter Foreman	hr	-40	\$74.14	-\$2,965.60
Carpenter	hr	-24	\$66.82	-\$1,603.68
Cement Mason Foreman	hr	-40	\$77.22	-\$3,088.80
Straight Time Post 7/1/16				
Foreman	hr	152	\$89.32	\$13,576.64
Operator	hr	304	\$81.99	\$24,924.96
Laborer (3 Men)	hr	456	\$63.04	\$28,746.24
Carpenter Foreman	hr	40	\$75.85	\$3,034.00
Carpenter	hr	24	\$68.53	\$1,644.72
Cement Mason Foreman	hr	40	\$77.82	\$3,112.80
Subtotal Labor				\$1,864.72
Equipment				
Equipment Subtotal				\$0.00
Subcontractor				
Subtotal Subcontractor				\$0.00
Subtotal Cost				\$1,864.72
Markup Material	15.00%			\$0.00
Markup Labor	15.00%			\$279.71
Markup Equipment	15.00%			\$0.00
Markup Subcontractor	5.00%			\$0.00
Subtotal Change Order Request				\$2,144.43
Bond	0.00%			\$0.00
Total Change Order Request				\$2,144.43

Preliminary Schedule

WBS / Activity

Leonwood Elementary Reconstruction (Option B: 2 Phases) *Copy on 1.Feb.2016

Activity ID	Planned Duration	Remarks	Start	End
74	P1.CX.1010	Final Clean & Punch	May/11/17 8:00 AM	May/12/17 8:00 AM
54	PUN.1.1000	Final Clean	May/12/17 8:00 AM	May/21/17 8:00 AM
55	PUN.1.1010	Swireton Punchlist	May/12/17 8:00 AM	May/25/17 8:00 AM
56	PUN.1.1020	Owner/Architect Punchlist	May/25/17 8:00 AM	Jun/5/17 8:00 AM
57	PUN.1.1030	Swireton Final Punch Corrections	Jun/5/17 8:00 AM	Jun/25/17 8:00 AM
58	A1350	Rain Days	Jun/25/17 8:00 AM	Jun/29/17 4:00 PM
59	PUN.1.1040	Phase 1 Complete	Jun/29/17 4:00 PM	Jun/29/17 8:00 AM
2800	Site Prep	Notify A&M	Jun/10/16 8:00 AM	Jun/10/16 8:00 AM
474	P2.2000	District Salvage & Move Out	Jun/17/16 8:00 AM	Jun/17/16 8:00 AM
104	P2.1000	Temp. Fencing	Jun/17/16 8:00 AM	Jun/17/16 8:00 AM
54	P2.005	Beginning of 2016 Summer Break	Jun/17/16 8:00 AM	Jun/20/16 8:00 AM
24	P2.1030	Site Survey and Layout Extent of Demo	Jun/20/16 8:00 AM	Jun/20/16 8:00 AM
14	P2.1110	Disassemble Play Equipment	Jun/21/16 8:00 AM	Jun/21/16 8:00 AM
34	A1320	Demo Existing Portables	Jun/21/16 8:00 AM	Jun/24/16 8:00 AM
34	P2.1100	Clear and Grub	Jun/24/16 8:00 AM	Jun/24/16 8:00 AM
34	P2.1040	Layout Bldg. Over-Excavation Limits	Jun/24/16 8:00 AM	Jun/24/16 8:00 AM
14	P2.1120	Safe-off/Out and Cap Existing Utilities	Jul/5/16 8:00 AM	Jul/5/16 8:00 AM
34	P2.1050	Over-Excavation	Jul/12/16 8:00 AM	Aug/9/16 8:00 AM
54	P2.1140	Pipe Crushed Rock/Geo-Grid Fabric	Aug/9/16 8:00 AM	Aug/16/16 8:00 AM
54	P2.1150	Soil Re-Compaction	Aug/16/16 8:00 AM	Aug/16/16 8:00 AM
14	P2.1160	Certify Building Post-Survey Layout Guidelines	Aug/16/16 8:00 AM	Aug/16/16 8:00 AM
914	East (Between Portables and Building)	Excavate Water/Fire Water Line	Aug/16/16 8:00 AM	Aug/16/16 8:00 AM
24	P2.SU.E.1050	Excavate Irrigation Water Line	Aug/16/16 8:00 AM	Aug/16/16 8:00 AM
24	P2.SU.E.1070	Install Water/Fire Water Line	Aug/16/16 8:00 AM	Aug/16/16 8:00 AM
34	P2.SU.E.1080	Install Irrigation Water Line	Aug/16/16 8:00 AM	Aug/16/16 8:00 AM
24	P2.SU.E.1180	Hydro Test	Aug/23/16 8:00 AM	Aug/23/16 8:00 AM
14	P2.SU.E.1190	Inspection	Aug/23/16 8:00 AM	Aug/23/16 8:00 AM
24	P2.SU.E.1000	Backfill and Compaction Water/Fire Water/Irrigation	Aug/24/16 8:00 AM	Aug/24/16 8:00 AM
24	P2.SU.E.1010	Layout and Excavate Sanitary Sewer Trench (East to We...)	Aug/24/16 8:00 AM	Aug/24/16 8:00 AM
24	P2.SU.E.1020	Install Site Underground Storm Drain Trench	Aug/24/16 8:00 AM	Aug/24/16 8:00 AM
24	P2.SU.E.1030	Layout and Excavate Storm Drain Trench	Aug/24/16 8:00 AM	Aug/24/16 8:00 AM
24	P2.SU.E.1040	Install Site Underground Storm Drain Lines (East)	Aug/24/16 8:00 AM	Aug/24/16 8:00 AM
24	P2.SU.E.1060	Backfill and Compaction Sewer	Aug/24/16 8:00 AM	Aug/24/16 8:00 AM
34	P2.SU.E.1090	Excavate Underground Electrical/Low Voltage Ductb...	Aug/24/16 8:00 AM	Aug/24/16 8:00 AM
34	P2.SU.E.1170	Pressure Test	Aug/24/16 8:00 AM	Aug/24/16 8:00 AM
54	P2.SU.E.1100	Install Underground Electrical/Low Voltage Ductbank	Aug/24/16 8:00 AM	Aug/24/16 8:00 AM
914	West	Layout and Excavate Storm Drain Trench (Southeast)	Jun/24/16 8:00 AM	Jun/24/16 8:00 AM
44	P2.SU.1170	Install Site Underground Storm Drain Lines (South...	Jun/24/16 8:00 AM	Jun/24/16 8:00 AM
64	P2.SU.1180	Pressure Test	Jul/1/16 8:00 AM	Jul/1/16 8:00 AM
14	P2.SU.1190	Excavate Water/Fire Water Line	Aug/23/16 8:00 AM	Aug/23/16 8:00 AM
44	P2.SU.1080	Excavate Irrigation Water Line	Aug/23/16 8:00 AM	Aug/23/16 8:00 AM
54	P2.SU.1090	Install Water/Fire Water Line	Aug/23/16 8:00 AM	Aug/23/16 8:00 AM
64	P2.SU.1200	Install Irrigation Water Line	Aug/23/16 8:00 AM	Aug/23/16 8:00 AM
14	P2.SU.1210	Hydro Test	Sep/7/16 8:00 AM	Sep/7/16 8:00 AM
14	P2.SU.1220	Inspection	Sep/8/16 8:00 AM	Sep/8/16 8:00 AM
14	P2.SU.1000	Slurry Backfill Utility Trenches	Sep/12/16 8:00 AM	Sep/12/16 8:00 AM
34	P2.SU.1010	Layout and Excavate Sanitary Sewer Trench (East to ...)	Sep/12/16 8:00 AM	Sep/12/16 8:00 AM
34	P2.SU.1020	Install Site Underground Storm Drain Trench	Sep/12/16 8:00 AM	Sep/12/16 8:00 AM
34	P2.SU.1030	Layout and Excavate Storm Drain Trench	Sep/12/16 8:00 AM	Sep/12/16 8:00 AM
64	P2.SU.1040	Install Site Underground Storm Drain Lines (West)	Sep/29/16 8:00 AM	Sep/29/16 8:00 AM
44	P2.SU.1060	Backfill and Compaction Sewer	Sep/29/16 8:00 AM	Sep/29/16 8:00 AM

5 DAYS

5/20/16



SWINERTON

March 4, 2019

Oxnard School District
1051 South A Street
Oxnard, CA, 93030

Attn: Mario Mera

Subject: Swinerton Builders Job 16055106 - Lemonwood K-8 School LLB
PCI No. 0478 Reimburse expended labor cost incurred by Abdellatif Enterprises

Dear Mr. Mera,

We request a Change Order to our contract for the following:

The first few change orders quoted by Abdellatif incorporated the wrong labor rate for this project. This change order request is for the difference in cost vs. quoted price

Phase	Category	Description	Subcontractor	Quote
061000	71140	The first few change orders quoted by Abdellatif incorporated the wrong labor rate for this project. This change order request is for the difference in cost vs. quoted price	ABDELLATIF ENTERPRISES, INC.	3,348.89
			Subtotal	3,348.89
007480	71160	Subguard	1.15%	38.51
007410	71160	Builders Risk	0.6%	20.32
007420	71160	General Insurance	1.15%	38.96
007510	71160	P&P Bond	1%	33.49
991000	79999	Change Order Fee	5%	172.34
			Markup Subtotal	303.62
			PCI Total	3,652.51

TOTAL AMOUNT OF THIS CHANGE ORDER REQUEST: **3,652.51**.

Please NOTE:

- » The incorporation of this revision in to the contractual scope of work may have an impact on our schedule, which is yet to be finalized. Once determined, the job schedule will be adjusted accordingly to show the effect of this revision on the final project completion date..
- » The terms (cost and schedule impact) of this change order request are subject to review and a requote if not accepted within days of its issuance.
- » This request does not include additional cost or delay due to late approval.



SWINERTON

We **HAVE** proceeded with this revised work per your instructions. Please issue a change order.

Upon acceptance of this change order request, a formal change order will be issued. Acceptance also acknowledges that Swinerton Builders has proceeded with the above change in scope.

If you have any questions or comments pertaining to this matter, please contact the undersigned.

Sincerely,
Swinerton Builders

Date: 3/4/2019

Quotation accepted by:
Oxnard School District

By: _____

Date: _____



Change Order # 19R

ORIGINAL DATE: April 11, 2017

REVISION DATE: May 1, 2017

PROJECT: Lemonwood K-8 School LLB

Cost proposal associated with incorrect labor rate used on approved subcontractor change orders

Description: Incorrect labor rate used on approved change orders. (PSI insurance)

PCI #

18
18
18
42
82
92
123
144
141
175

Description	Qty	Unit	Unit Price	Extension
change order 1	38	hours		
change order 2	40	hours		
change order 2 (OT Hours)	8	hours		
change order 5	32	hours		
change order 8	31	hours		
change order 9	2	hours		
change order 13	66	hours		
change order 14	57	hours		
change order 15	120	hours		
change order 17	94	hours		
Material Subtotal				\$ -
Material Sales Tax				\$ -
Material Delivery				\$ -
Material Total				\$ -
Journeyman Labor	480	Hours	\$ 5.96	\$ 2,860.80
Journeyman Overtime Labor	8	Hours	\$ 6.41	\$ 51.28
Subtotal				\$ 2,912.08
Profit & Overhead	15%			\$ 436.81
Total Change Order				\$ 3,348.89



Change Order # 1

DATE: August 17, 2016

PROJECT: Lemonwood K-8 School LLB

Cost proposal associated with building temporary ramps.

Description: Cost associated with building temporary ramps and adding posts in concrete holes.

Description: Temporary ramps				
Base cost				\$ 20,000.00
Subtotal				\$ 20,000.00

Details adding posts in concrete holes				
Description	Qty	Unit	Unit Price	Extension
See attached receipts				\$ 1,527.95
Material Subtotal				\$ 1,527.95
Material Sales Tax				\$ -
Material Total				\$ -
Labor	38		\$ 64.24	\$ 2,441.12
Subtotal				\$ 3,969.07
Profit & Overhead	15%			\$ 595.36
Subtotal for changed details				\$ 4,564.43

Change Order Total: \$ 24,564.43



Change Order # 2

DATE: August 17, 2016

PROJECT: Lemonwood K-8 School LLB

Cost proposal associated with painting deck and ramp

Description: Cost associated with painting the deck and temporary ramp

Description	Qty	Unit	Unit Price	Extension
See attached				\$ 1,055.90
Material Subtotal				\$ 1,055.90
Material Sales Tax				\$ -
Material Total				\$ -
Labor	40		\$ 64.24	\$ 2,569.60
Labor (Overtime Foreman)	4		\$ 92.56	\$ 370.24
Labor (Overtime)	4		\$ 87.40	\$ 349.60
Subtotal				\$ 3,625.50
Profit & Overhead	15%			\$ 543.83
Total Change Order				\$ 4,169.33



Change Order #

5

DATE: September 29, 2016

PROJECT: Lemonwood K-8 School LLB

Cost proposal associated with RFI 48 and 48R1

Description: RFI 48 (Answer 9) added post type F along grid 3 (the add is for the HD19). RFI 48R1 (Answer2) changed single sided shear walls on both floor to double sided shear walls on both floors.

Materials	Qty	Unit	Unit Price	Extension
HD19 DF #1	1		\$ 90.50	\$ 90.50
1" x 8" machine bolts	5		\$ 1.59	\$ 7.95
1" plate washers	5		\$ 1.89	\$ 9.45
1 1/4" x 30" allthread	1		\$ 5.25	\$ 5.25
4x4x1/2" plate washer	1		\$ 4.95	\$ 4.95
Material Subtotal				\$ 118.10
Material Sales Tax				\$ 10.63
Material Total				\$ 128.73
Labor	2		\$ 64.24	\$ 128.48
Subtotal Material & Labor				\$ 257.21
Profit & Overhead	15%			\$ 38.58
Subtotal				\$ 295.79

Description: Change shear wall along 3 line to double sided on both floors. Studs change from 3x to 2x at plywood breaks.

Materials	Qty	Unit	Unit Price	Extension
1/2x4x8 CDX Struct 1 plywood	30		\$ 21.75	\$ 652.50
3x6x12 DF #1	18		\$ 17.42	\$ 313.56
2x6x12 DF #1 Dry	-18		\$ 10.25	\$ (184.50)
Material Subtotal				\$ 781.56
Material Sales Tax				\$ 78.16
Material Total				\$ 859.72
Labor	30		\$ 64.24	\$ 1,927.20
Subtotal Material & Labor				\$ 2,786.92
Profit & Overhead	15%			\$ 418.04
Subtotal				\$ 3,204.96

Change Order Total:

\$ 3,500.75



Lemonwood Change Order 8

Additional Cost associated with RFI 147.

Description: Plans did not show support details for the coridor soffits. RFI 147 is requiring us to install new 6x12 beams for soffit support. This pricing is for the material and installation of the 6x12 beams only.

New material

Labor

31 hours	Install and bolt added 6x12s	Rate	\$ 64.24	hour	\$ 1,991.44
----------	------------------------------	------	----------	------	-------------

Material

10 pc	6x12x22' DF #1 dry	\$ 207.00	\$ 2,070.00
6 pc	6x12x10' DF #1 dry	\$ 169.36	\$ 1,016.16
2 pc	6x12x18' DF #1 dry	\$ 94.00	\$ 188.00
8	HUC612	\$ 25.89	\$ 207.12
52	5/8"x7" machine bolts	\$ 2.25	\$ 117.00
52	5/8" nuts	\$ 0.35	\$ 18.20
150	LUS26	\$ 0.75	\$ 112.50

Material Tax	\$ 291.40
---------------------	-----------

Material delivery	\$ 350.00
--------------------------	-----------

Subtotal	\$ 6,361.82
-----------------	-------------

Profit and Overhead	15%	\$ 954.27
----------------------------	-----	-----------

Change order Total	\$ 7,316
---------------------------	----------



Change Order # 9

DATE: December 9, 2016

PROJECT: Lemonwood K-8 School LLB

Cost proposal associated with RFI 165

Description: Add hanger per RFI 165

Description	Qty	Unit	Unit Price	Extension
HHGU7x24	1			\$ 209.00
Material Subtotal				\$ 209.00
Material Sales Tax				\$ 18.81
Material Total				\$ 227.81
Labor	2		\$ 64.24	\$ 128.48
Subtotal				\$ 356.29
Profit & Overhead	15%			\$ 53.44
Total Change Order				\$ 409.73



Change Order # 13

DATE: January 26, 2016

PROJECT: Lemonwood K-8 School LLB

Cost proposal associated with RFI 185

Description: Add 2x12 ledger at corridor with 4 1/2 SDS

Description	Qty	Unit	Unit Price	Extension
2x12	420'		\$ 2.50	\$ 1,050.00
1/4 x 4 1/2 SDS	636		\$ 348.60	\$ 384.60
Material Subtotal				\$ 1,434.60
Material Sales Tax				\$ 115.01
Material Delivery				\$ 200.00
Material Total				\$ 1,749.61
Labor	66		\$ 64.24	\$ 4,239.84
Subtotal				\$ 5,989.45
Profit & Overhead	15%			\$ 898.42
Total Change Order				\$ 6,887.87



Change Order # 14

DATE: January 26, 2016

PROJECT: Lemonwood K-8 School LLB

Cost proposal associated with CCD 17

Description: Add posts and holddowns from floor to roof along grid D

Description	Qty	Unit	Unit Price	Extension
6x6x14 DF #1 Dry	6		\$ 49.00	\$ 294.00
3x6x14 DF #1 Dry	3		\$ 38.50	\$ 115.50
7/8x4' allthread	4		\$ 13.00	\$ 52.00
7/8x4' allthread HDG A36	2		\$ 17.00	\$ 34.00
HDU8	10		\$ 32.25	\$ 322.50
Set-XP Simpson Epoxy	2		\$ 27.54	\$ 55.08
7/8" nuts	10		\$ 0.65	\$ 6.50
1"x31" roto hammer bit	1		\$ 91.97	\$ 91.97
Material Subtotal				\$ 971.55
Material Sales Tax				\$ 91.53
Material Delivery				\$ 200.00
Material Total				\$ 1,263.08
Labor (add 6 new post)	19		\$ 64.24	\$ 1,220.56
Labor (install 10 HD10s & allthread)	38		\$ 64.24	\$ 2,441.12
Subtotal				\$ 4,924.76
Profit & Overhead	15%			\$ 738.71
Total Change Order				\$ 5,663.47



Lemonwood Change Order 15 Revised

Additional Cost associated with Bulletin 32.

Description: Bulletin 32 requires blocking for the power exhaust support post.

Labor

120 hours	Install blocking for 128 post	Rate	\$ 64.24	hour	\$ 7,708.80
-----------	-------------------------------	------	----------	------	-------------

Material

18 pc	4x4x16' DF #1	\$ 24.00	\$ 432.00
282 pc	huc44	\$ 4.87	\$ 1,373.34
10 pc	2x12x16 DF #1	\$ 26.76	\$ 267.60
2 bx	1 1/2" PP nails	\$ 42.00	\$ 84.00
1	3 1/4"x3" gun nails	\$ 50.00	\$ 50.00

Material Tax \$ 160.68

Material delivery \$ 200.00

Subtotal \$ 10,276.42

Profit and Overhead 15% \$ 1,541.46

Change order Total \$ 11,818



Change Order #

17

DATE: March 20, 2016

PROJECT: Lemonwood K-8 School LLB

Cost proposal associated with RFI 233

Description: Move FSCs, CS14s, and 2x6 where required for the framing of roof scupper openings

Description	Qty	Unit	Unit Price	Extension
Material Subtotal				\$ -
Material Sales Tax				\$ -
Material Delivery				\$ -
Material Total				\$ -
Labor (frame openings)	94		\$ 64.24	\$ 6,038.56
Subtotal				\$ 6,038.56
Profit & Overhead	15%			\$ 905.78
Total Change Order				\$ 6,944.34

CONSTRUCTION SERVICES AGREEMENT #15-198

This Construction Services Agreement (hereinafter referred to as the "Agreement") is entered into this 2nd day of March, 2016, by and between the Oxnard School District, a California school district organized and existing under the laws of the State of California (hereinafter referred to as the "District") and Swinerton Builders which is a contractor licensed by the State of California, with its principal place of business at 865 S. Figueroa St., Suite 3000, Los Angeles, CA 90017 (hereinafter referred to as "Contractor").

WHEREAS, the District operates Lemonwood K-8 School, located at 2200 Carnegie Court Oxnard, California 93033 (hereinafter referred to as the "School Facility"); and

WHEREAS, the District desires to construct and modernize facilities and improvements (as more fully described below) at those portions of the School Facility identified in the Site Lease, as defined in Section 1G below (the "Site"); and

WHEREAS, the District has determined that it is in its best interests to pursue the improvements to the School Facility through the lease-leaseback method of project delivery pursuant to California Education Code §17406 which permits the governing board of the District, without advertising for bids, to lease to Contractor property owned by the District if the instrument by which property is leased requires the lessee to construct, or provide for the construction, on the leased property, of a facility for the use of the District during the term of the lease, and provides that title to that facility shall vest in the District at the expiration of the lease; and

WHEREAS, the District desires to finance a portion of the improvements utilizing the lease/leaseback methodology; and

WHEREAS, the District has conducted an RFQ process by which it selected Contractor; and

WHEREAS, the District intends to undertake work to improve the School Facility, the scope of which is generally described in **Exhibit A** attached hereto and incorporated by reference herein; and

WHEREAS, in connection with the approval of this Agreement, the District will enter into a site lease with Contractor, under which it will lease to Contractor the Site in order for Contractor to construct the Project as described in the Scope of Work set forth generally in **Exhibit A** (hereinafter referred to as the "Scope of Work"); and

WHEREAS, assuming that the District and Contractor can agree on the terms, including the price, for the additional scope of work, the District and Contractor anticipate that the scope of the Project may be amended to include additional work; and

WHEREAS, Contractor will lease the Site back to the District pursuant to a sublease agreement, under which the District will be required to make payments to Contractor for the use and occupancy of the Site, including the Project (hereinafter the "Financing"); and

WHEREAS, Contractor represents that it is sufficiently experienced in the construction of the type of facility and type of work sought by the District and is willing to perform said work for lease and the Financing to the District, all as more fully set forth herein; and

WHEREAS, at the expiration of the Site Lease, title to the Site and the improvements thereon will vest with the District;

NOW, THEREFORE, in consideration of the covenants hereinafter contained, the District and Contractor agree as follows:

SECTION 1. DEFINITIONS

- A. **Construction.** The term "Construction" as used in this Agreement includes all labor and services necessary for the construction of the Project, and all materials, equipment, tools, supplies and incidentals incorporated or to be incorporated in such construction as fully described in the Scope of Work set forth in **Exhibit A** attached hereto. Unless otherwise expressly stipulated, Contractor shall perform all work and provide and pay for all materials, labor tools and equipment, including, but not limited to, light, water, and power, necessary for the proper execution and completion of the Project shown on the drawings and described in the specifications developed pursuant to this Agreement.
- B. **Construction Documents.** The term "Construction Documents" means the final drawings, profiles, cross sections, design development drawings, construction drawings, and supplemental drawings based on the plans and specifications developed for the Project pursuant to the Scope of Work set forth in **Exhibit A** attached hereto, including any reference specifications or reproductions prepared by the architect hired by the District (the "Architect") and specifications approved by the District, the Division of the State Architect ("DSA"), and the local agencies having jurisdiction or other regulatory agencies whose approval may be required, which show or describe the location, character, dimensions or details for the Project and specifications for construction thereof.
- C. **Contract Documents.** The term "Contract Documents" as used in this Agreement refers to those documents which form the entire agreement by and between the District and Contractor. The Contract Documents consist of this Agreement, including the exhibits and attachments hereto, the Site Lease, including the exhibits and attachments thereto, the Sublease, including the exhibits and attachments thereto, the Project Manual including the General Conditions thereto, as amended,

which is incorporated herein (the "General Conditions"), and the Construction Documents. The term "Contract Documents" shall include all modifications and addenda thereto.

- D. **Guaranteed Maximum Price.** The term "Guaranteed Maximum Price" or "GMP" as used in this Agreement means the Guaranteed Maximum Price established pursuant to Section 5 of this Agreement to be used to calculate the Tenant Improvement Payments and the Sublease Payments to be paid by the District to Contractor pursuant to the Sublease, subject only to any adjustments for Extra Work/Modifications as provided in Section 10 of this Agreement.
- E. **Project.** The term "Project" shall mean the improvements and facilities to be constructed and installed by Contractor at the School Facility which will result in complete and fully operational facilities as more fully set forth on **Exhibit A** attached hereto.
- F. **Project Manual.** The term "Project Manual" shall mean the compilation of the Specification sections including Division 0, Procurement and Contracting Requirements, Division 1 General Requirements, and technical specifications Division 2 through 33 prepared by the Architect and approved by the District, the DSA, or other regulatory agencies which show or describe the location, character, dimensions or details for the Project, which shall be delivered to Contractor upon execution of this Agreement.
- G. **Site.** The term "Site" as used in this Agreement shall mean those certain parcels of real property and improvements thereon (if any) more particularly described in **Exhibit A** to the Site Lease.
- H. **Site Lease.** The term "Site Lease" as used in this Agreement shall mean the certain Site Lease dated of even date herein between the District and Contractor, together with any duly authorized and executed amendment(s) thereto, pursuant to which the District leases the Site to Contractor.
- I. **Specifications.** The term "Specifications" shall mean those numbered specifications set forth in the Project Manual which shall accompany this Agreement and which are incorporated by reference herein. Individual Specifications may be referred to by their specification number as set forth in the Project Manual.
- J. **Subcontractor.** As used in this Agreement, the term "Subcontractor" means any person or entity, including trade contractors, who have a contract with Contractor to perform any of the Construction.
- K. **Sublease.** The term "Sublease" as used in this Agreement shall mean the certain Sublease dated of even date herein between the District and Contractor, together

with any duly authorized and executed amendment(s) thereto, pursuant to which the District subleases the Site from Contractor.

L. **Sublease Payments.** The term "Sublease Payments" as used in this Agreement shall mean the payments made by the District to Contractor pursuant to Section 6 of the Sublease.

M. **Tenant Improvement Payments.** The term "Tenant Improvement Payments" as used in this Agreement shall mean the payments made by the District to Contractor pursuant to Section 6 of the Sublease.

SECTION 2. CONTRACTOR'S DUTIES AND STATUS

Contractor covenants with the District to furnish reasonable skill and judgment in constructing the Project. Contractor agrees to furnish efficient business administration and superintendence and to furnish at all times an adequate supply of professionals, workers, and materials and to perform the work appropriately, expeditiously, economically, and consistent with the Contract Documents.

SECTION 3. ADDITIONAL SERVICES

If the District requests Contractor to perform additional services not described in this Agreement, Contractor shall provide a cost estimate and a written description of the additional work necessary to complete such additional services. The cost for such additional services shall be negotiated and agreed upon in writing in advance of Contractor performing or contracting for such additional services, and such cost shall be used to adjust the GMP established pursuant to Section 5 hereof. In the absence of a written agreement, the District will not compensate Contractor for additional services, will not adjust the GMP for such additional services, and Contractor will not be required to perform them. It is understood and agreed that if Contractor performs any services that it claims are additional services without receiving prior written approval from the District Board of Education, Contractor shall not be paid for such claimed additional services and the GMP will not be adjusted. Nothing in this Agreement shall be construed as limiting the valuation of such additional services and amount that the GMP will be adjusted for such additional services, should a written agreement for such services be executed by the parties. Notwithstanding the foregoing, Contractor shall not be entitled to compensation, nor will the GMP be adjusted, for additional services required as a result of Contractor's acts, errors or omissions.

SECTION 4. OWNERSHIP OF PLANS AND DOCUMENTS

All original field notes, written reports, drawings, specifications, Construction Documents, and other documents, produced or developed for the Project are the property of the District, regardless of whether the Project is constructed, and shall be furnished to the District. Such documents are not to be used by Contractor or by the Subcontractors on other work nor shall

Contractor nor the Subcontractors claim any right to such documents. This shall not deprive Contractor from retaining electronic data or other reproducible copies of the Construction Documents or the right to reuse information contained in them in the normal course of Contractor's professional activities.

SECTION 5. ESTABLISHMENT OF GUARANTEED MAXIMUM PRICE

The "GMP" for the Project shall be Twenty-Nine Million, Five Hundred Seventy-Five Thousand, Eight Hundred Ninety-Seven Dollars and Ninety-One Cents (\$29,575,897.91). The GMP consists of (1) Sublease Tenant Improvement Payments in the amount of Twenty -Five Million, Four Hundred Eight Thousand One Hundred Eight-Eight Dollars (\$25,408,188.91) and, (2) a Contractor Contingency in the amount of Seven Hundred Forty-Seven Thousand, Seven Hundred and Nine Dollars and No Cents (\$747,709.00), and, (3) Sublease Payments in the amount of \$90,000.00 per month not to exceed a total lease value of \$3,420,000.00 pursuant to terms and payment schedule as set forth in the Sublease.

The GMP is based upon the plans and specifications existing at the time this Agreement is entered into between Contractor and the District, and more fully described and referenced in the Scope of Work set forth in **Exhibit A** attached hereto. Contractor shall assume the risk of cost overruns which were not foreseeable at the time this Agreement is entered into and the GMP determined, except for undocumented events of the type set forth in Section 19 hereof, work mandated by an outside agency after issuance of Construction Documents that could not have been reasonably foreseen from review of the Contract Documents, or costs arising from undocumented geotechnical issues. Contractor acknowledges that (i) Contractor has conducted a site inspection and is familiar with the site conditions based on records, studies and visible conditions relating to construction and labor and (ii) Contractor has reviewed the Contract Documents and is familiar with the contents thereof. District directed changes to the scope of the Project not contemplated in the Scope of Work shall be deemed Extra Work/Modifications pursuant to the procedures set forth in Section 10 of this Agreement. The GMP shall include, but not be limited to, increases in labor and materials. The GMP has been used to calculate the Tenant Improvement Payments and the Sublease Payments to be paid by the District to Contractor pursuant to the Sublease. The GMP includes the cost of all labor, materials, equipment, general conditions, overhead, profit and a Contractor Contingency as indicated above.

The Contractor Contingency is for the purpose of covering the cost of very specific issues that may arise during construction and it may be used only upon the written agreement of the Contractor, the architect of record, and the District. The Contractor Contingency is to be used only to pay Contractor for the following enumerated reasons: (1) additional costs resulting from discrepancies in the bid buy-out process; (2) conflicts, discrepancies or errors in the Construction Documents; (3) work required by the Inspector of Record or any governmental agency involved in the permitting or approval/certification process that is not otherwise shown in the Construction Documents; and (4) any other items of cost agreed to in writing by the Contractor and District to be included in the Contractor Contingency. The Contractor

Contingency shall not be used for costs incurred as a result of Contractor's acts, errors or omissions.

Contractor shall be responsible for tracking expenditures of the Contractor Contingency and shall provide periodic written updates to the District as directed. Contractor shall be entitled to retain unused Contractor Contingency up to a maximum of \$150,000; unused Contractor Contingency over \$150,000 and unused Allowances at Project completion shall reduce the GMP and will result in an adjustment of the Tenant Improvement Payments and possibly the Sublease Payments.

The District shall at all times have the right to reduce the scope of the Project. If the District reduces the scope of the Project, the GMP shall be reduced commensurate with the reduced Scope of Work pursuant to the provisions of Section 10, below, and will result in an adjustment of the Tenant Improvement Payments and, if applicable, the Sublease Payments.

SECTION 6. NOTICE TO PROCEED WITH CONSTRUCTION

Upon receipt of an approved GMP, the District shall issue a notice to Contractor to proceed with the Construction of the Project. In the event that a Notice to Proceed with Construction is not issued for the Project, the Site Lease and the Sublease shall terminate upon written notice from the District to Contractor that a Notice of Proceed will not be issued.

SECTION 7. SAVINGS

If Contractor realizes a savings on one aspect of the Project, such savings shall be tracked and Contractor shall provide periodic written updates of such savings. Such savings shall be added to the Contractor Contingency and the use of such savings shall be as set forth in Section 5. However, if such savings are not so utilized, the amount of such savings shall reduce the GMP and will result in an adjustment of the Tenant Improvement Payments and, if applicable, the Sublease Payments.

SECTION 8. SELECTION OF SUBCONTRACTORS

In the interest of minimizing the expenditure of funds for the construction of the Project, Contractor agrees to select Subcontractors who are appropriately licensed by the State of California for each trade component of the Project in a manner that fosters competition. Contractor agrees that it will either solicit bids from potential subcontractors pursuant to the competitive bid procedures set forth in the California Public Contract Code, including specifically Public Contract Code section 20110, et seq., or that it will utilize an informal bidding process established by Contractor which also incorporates competitive bid procedures. Regardless of the method Contractor employs, Contractor will make a good faith effort to contact and utilize DVBE contractors and suppliers in securing bids for performance of the Project in accordance with the procedures set forth in Section 1.77 of the General Conditions. In the event that Contractor chooses to select Subcontractors pursuant to an informal bidding

process, Contractor shall ensure that it receives at least three competitive quotes from potential subcontractors for each trade component of the Project, unless the parties agree otherwise on a trade-by-trade basis. The District reserves the right to oversee the bidding process. Contractor shall inform all bidders that the District will not be a party to any contracts for construction services executed by Contractor and selected bidders. Contractor shall submit a listing of proposed subcontractors to the District for the District's review. In no case will Contractor award any sub-contracts until the District has concurred in the scope and price of the sub-contracted services. In addition, Contractor shall provide the District with full documentation regarding the bids or competitive quotes received by Contractor. In no event shall such documentation be redacted or obliterated. In the event Contractor does not comply with this provision, the District may terminate this Agreement in accordance with the provisions of the General Conditions. Subcontractors awarded contracts by Contractor shall be afforded all the rights and protections of listed subcontractors under the provisions of the Subletting and Subcontracting Fair Practices Act (Public Contract Code Section 4100, et seq.).

SECTION 9. CONSTRUCTION SCOPE OF WORK

- A. Prior to commencing Construction, Contractor shall comply with the initial schedule requirements set forth in the General Conditions.
- B. Contractor shall complete the Construction pursuant to the Construction Documents as amended subject to any additional DSA or other regulatory approvals as may be required, performing all work set forth in the Scope of Work, and shall make reasonable efforts in scheduling to prevent disruption to classes.
- C. Contractor shall be responsible for complying with all applicable building codes, including without limitation mechanical codes, electrical codes, plumbing codes and fire codes, each of the latest edition, required by the regulatory agencies and for arranging and overseeing all necessary inspections and tests including inspections by the DSA or regulatory agencies, permits and occupancy permits, and ensuring compliance with any Federal and State laws, including, but not limited to, safety procedures and requirements, and construction employee training programs which cover among other items, hazardous chemicals and materials.
- D. Contractor shall establish procedures for the protection of all existing structures, equipment, utilities, and other existing improvements, both on-site and off-site. Contractor assumes all risk of loss of vandalism, theft of property or other property damage ("Vandalism") which occurs at a site at which Contractor is undertaking construction of the Project. Contractor assumes all risk of loss which occurs at a site at which Contractor is undertaking construction of the Project from causes due to negligence or misconduct by Contractor, its officers, employees, subcontractors, licensees and invitees. Contractor shall replace District property damaged by such Vandalism or theft or compensate the District for such loss, including payment of out

of pocket expenses such as insurance deductibles the District might incur under such circumstances.

- E. Contractor shall develop a mutually agreed upon program with the District to abate and minimize noise, dust, and disruption to normal activities at the existing facilities at the School Facility, including procedures to control on-site noise, dust, and pollution during construction.
- F. The District shall cause the appropriate professionals to stamp and sign, as required, the original Construction Documents or parts thereof and coordinate the Project's design with all utilities.
- G. Contractor shall, for the benefit of the Subcontractors, attend pre-construction orientation conferences in conjunction with the Architect to set forth the various reporting procedures and site rules prior to the commencement of actual construction. Contractor shall also attend construction and progress meetings with District representatives and other interested parties, as requested by the District, to discuss such matters as procedures, progress problems and scheduling. Contractor shall prepare and promptly distribute official minutes of such meetings to all parties in attendance, including without limitation the District, the Architect and the District Inspector of Record.
- H. Contractor shall incorporate approved changes as they occur, and develop cash flow reports and forecasts for submittal to the District as requested. Contractor shall provide regular monitoring of the approved estimates for Construction costs, showing actual costs for activities in progress, and estimates for uncompleted tasks. Contractor shall maintain cost accounting records on authorized additional services or work performed under unit costs, additional work performed on the basis of actual costs of labor and materials, and for other work requiring accounting records.
- I. Contractor shall record the progress of the Project and shall submit monthly written progress reports to the District and the Architect including information on the entire Project, showing percentages of completion and the number and amounts of proposed Extra Work/Modifications and their effect on the construction costs as of the date of each respective report.
- J. Contractor shall keep a log containing a record of weather, Subcontractors, work on the site, number of workers, work accomplished, problems encountered, and other similar relevant data as the District may require. Contractor shall make the log available to the District, the Architect, and the District's project manager. The District shall be promptly advised on all anticipated delays in the Project.

- K. The District shall bear the cost for the DSA Inspector, soils testing, DSA or other regulatory agency fees, and special testing required in the construction of the Project. If additional review or permits become necessary for reasons not due to Contractor's fault or because of DSA or regulatory agency requirements or regulations implemented after the date the Final GMP is established and not reasonably anticipated at the time the Final GMP is established, Contractor may seek additional compensation for the cost of that review as an additional cost. In the alternative, the District may pay such costs directly.

SECTION 10. EXTRA WORK/MODIFICATIONS

- A. The District may prescribe or approve additional work or a modification of requirements or of methods of performing the Construction which differ from the work or requirements set forth in the Construction Documents ("Extra Work/Modifications"); and for such purposes the District may at any time during the life of this Agreement, by written order, make such changes as it shall find necessary in the design, line, grade, form, location, dimensions, plan, or material of any part of the work or equipment specified in this Agreement or in the Construction Documents, or in the quantity or character of the work or equipment to be furnished. In the event conditions develop which, in the opinion of Contractor, makes strict compliance with the specifications impractical, Contractor shall notify the District of the need for Extra Work/Modifications by placing the matter on the agenda of regularly scheduled construction meetings with the District for discussion as soon as practicable after the need for the Extra Work/Modifications is determined. Additionally, Contractor shall submit to the District for its consideration and approval or disapproval, a written request for Extra Work/Modifications before such work is performed. If the District approves the request in writing, the costs of the Extra Work/Modification shall be added to or deducted from the GMP or the Scope of Work shall be modified to complete the Project within the GMP, as applicable. Any adjustments to the GMP will result in an adjustment of the Tenant Improvement Payments and, if applicable, the Sublease Payments.

Contractor has proposed a GMP that is based on the Construction

Documents. Contractor, prior to proposing the GMP, was retained by the Owner to perform a comprehensive constructability review, value engineering and project cost estimating. In performing the constructability review, while Contractor's review was done in its role as Contractor, and not design professional, if Contractor discovered any errors, omissions, ambiguities, inconsistencies and other construction issues, Contractor brought such matters to the attention of Owner. Contractor recognizes that it shall not be entitled to an addition to the GMP for additional work related to issues of constructability, or for incidental work that could reasonably be inferred from the Construction Documents, or for any errors or omissions it discovered, or should have discovered, that it did not bring to the attention of the Owner.

- B. Extra Work/Modifications include work related to unforeseen underground conditions if, and only if, such conditions are not visible or identified on plans, reports or other documents available to Contractor. Extra Work/Modifications do not include underground conditions that are identified on plans, reports or other documents available to Contractor but are in a location different than is set forth on such plans, reports or other documents available to Contractor. It should be noted, however, that the District has advised and provided Contractor with information regarding the shallow water table and recent projects experience with encountering water when digging. Contractor has included in its calculation of the GMP an amount to mitigate for encountering water when completing the scope of work contemplated herein.
- C. Should Contractor claim that any instruction, request, drawing, specification, action, condition, omission, default or other situation (i) obligates the District to increase the GMP; or (ii) obligates the District to grant an extension of time for the completion of this Agreement; or (iii) constitutes a waiver of any provision in this Agreement, CONTRACTOR SHALL NOTIFY THE DISTRICT, IN WRITING, OF SUCH CLAIM AS SOON AS POSSIBLE, BUT IN NO EVENT WITHIN MORE THAN TEN (10) DAYS FROM THE DATE CONTRACTOR HAS ACTUAL OR CONSTRUCTIVE NOTICE OF THE CLAIM. CONTRACTOR SHALL ALSO PROVIDE THE DISTRICT WITH SUFFICIENT WRITTEN DOCUMENTATION SUPPORTING THE FACTUAL BASIS OF THE CLAIM including items used in valuing said claim. Contractor shall be required to certify under penalty of perjury the validity and accuracy of any claims submitted. Contractor's failure to notify the District within such ten (10) day period shall be deemed a waiver and relinquishment of the claim against the District.
- D. Expenses of reconstruction and/or costs to replace and/or repair damaged materials and supplies, provided that Contractor is not fully compensated for such expenses and/or costs by insurance or otherwise, shall be included in an increase to the GMP if said expenses are the result of the negligent acts or omissions of the District, or its principals, agents, servants, or employees.

SECTION 11. NOT USED

SECTION 12. PERSONNEL ASSIGNMENT

- A. Contractor shall assign Steven Augustine as Project Manager/Superintendent for the Project. So long as Steven Augustine remains in the employ of Contractor, such person shall not be changed or substituted from the Project, or cease to be fully committed to the Project except as provided in this Section. In the event Contractor deems it necessary, Contractor shall replace the manager and/or the superintendent for the Project with a replacement with like qualifications and experience, subject to

the prior written consent of the District, which consent shall not be unreasonably withheld. Any violation of the terms of paragraph A of this Section 12 shall entitle the District to terminate this Agreement for breach, pursuant to the provisions of the General Conditions.

- B. Notwithstanding the foregoing provisions of paragraph A of Section 12, above, if any manager and/or superintendent proves not to be satisfactory to the District, upon written notice from the District to Contractor, such person(s) shall be promptly replaced by a person who is acceptable to the District in accordance with the following procedures: Within five (5) business days after receipt of a notice from the District requesting replacement of any manager and/or superintendent or discovery by Contractor that any manager and/or superintendent is leaving their employ, as the case may be, Contractor shall provide the District with the name of an acceptable replacement/substitution together with such information as the District may reasonably request about such replacement/substitution. The replacement/substitution shall commence work on the Project no later than five (5) business days following the District's approval of such replacement, which approval shall not be unreasonably withheld. If the District and Contractor cannot agree as to the replacement/substitution, the District shall be entitled to terminate this Agreement for breach pursuant to the provisions of the General Conditions.

SECTION 13. BONDING REQUIREMENTS

Contractor shall fully comply with the requirements set forth in Section 6.9 of the General Conditions.

SECTION 14. PAYMENTS TO CONTRACTOR

- A. Contractor shall finance the cost of construction of the Project which costs shall not exceed the GMP, which shall not be adjusted except as otherwise provided in this Agreement. The District shall pay Contractor Tenant Improvement Payments and Sublease Payments pursuant to the terms and conditions of Section 6 of the Sublease. In the event of a dispute between the District and Contractor, the District may withhold from the Tenant Improvement Payments and the Sublease Payments an amount not to exceed one hundred fifty percent (150%) of the disputed amount.
- B. This Agreement is subject to the provisions of California Public Contract Code Sections 7107, 7201 and 20104.50 as they may from time to time be amended.
- C. For purposes of this Agreement, the acceptance by the District means acceptance made only by an action of the governing body of the District in session. Acceptance by Contractor of the final Tenant Improvement Payment or the Sublease Payment, as the case may be, shall constitute a waiver of all claims against the District related to those amounts.

SECTION 15. CONTRACTOR'S CONTINUING RESPONSIBILITY

Neither the final payment nor any provision in the Contract Documents shall relieve Contractor of responsibility for faulty materials or workmanship incorporated in the Project or for any failure to comply with the requirements of the Contract Documents.

SECTION 16. INSURANCE

Contractor shall provide, during the life of this Agreement, the types and amounts of insurance set forth in Article 6 of the General Conditions, which are incorporated by reference herein.

SECTION 17. USE OF PREMISES

Contractor shall confine operations at the Site to areas permitted by law, ordinances, permits and the Construction Documents and shall not unreasonably encumber the Site or existing School Facilities at the Site with any materials or equipment. Contractor shall not load or permit any part of the work to be loaded with a weight so as to endanger the safety of persons or property at the Site.

SECTION 18. SITE REPRESENTATIONS

The District warrants and represents that the District has, and will continue to retain at all times during the course of construction, legal title to the Site and that said land is properly subdivided and zoned so as to permit the construction and use of said Site with respect to the Project. The District further warrants and represents that title to said land is free of any easements, conditions, limitation, special permits, variances, agreements or restrictions which would prevent, limit or otherwise restrict the construction or use of said Site pursuant to this Agreement. Reference is made to the fact that the District has provided information on the Site to Contractor. Such information shall not relieve Contractor of its responsibility; and the interpretation of such data regarding the Site, as disclosed by any borings or other preliminary investigations, is not warranted or guaranteed, either expressly or implicitly, by the District. Contractor shall be responsible for having ascertained pertinent local conditions such as location, accessibility and general character of the Site and for having satisfied itself as to the conditions under which the work is to be performed. No claim for any allowances because of Contractor's error or negligence in acquainting itself with the conditions at the Site will be recognized.

SECTION 19. HAZARDOUS WASTE AND UNKNOWN PHYSICAL CONDITIONS

Contractor shall comply with the District's Hazardous Materials Procedures and Requirements as set forth herein.

- A. If the District has identified the presence of hazardous materials on or in proximity to the Site (the "Pre-existing Hazardous Materials"), Contractor shall review all information provided by the District that characterizes the Pre-existing Hazardous Materials and shall take the actions approved by DTSC and issued by the District necessary to address the Pre-existing Hazardous Materials in the performance of the work. Contractor shall conduct the work based on this information issued at the time contract documents are executed. Contractor shall immediately communicate, in writing, any variances from available information to the District.
- B. The District will retain an additional independent environmental consultant to perform the investigation, inspection, testing, assessment, sampling and analysis necessary to prepare and recommend a remediation plan for the Pre-existing Hazardous Materials for the District's approval (the "Remediation Plan").
- C. The District will retain title to all Pre-existing Hazardous Materials encountered during the work. This does not include hazardous material generated by Contractor, including but not limited to used motor oils, lubricants, cleaners, etc. Contractor shall dispose of such hazardous waste in accordance with the provisions of the Contract Documents, as well as local, State and Federal laws and regulations. The District will be shown as the hazardous waste generator and will sign all hazardous waste shipment manifests for non-Contractor generated hazardous waste. Nothing contained within these Contract Documents shall be construed or interpreted as requiring Contractor to assume the status of owner or generator of hazardous waste substances for non-Contractor generated hazardous wastes.
- D. Except as otherwise provided herein, it is the responsibility of Contractor to obtain governmental approvals relating to Hazardous Materials Management, including Federal and State surface water and groundwater discharge permits and permits for recycling and reuse of hazardous materials for all work noted in the contract documents. Contractor shall be responsible for coordinating compliance with such governmental approvals and applicable governmental rules with the District's hazardous materials consultant, including those governing the preparation of waste profiles, waste manifests, and bills of lading. If Contractor encounters hazardous materials, it shall immediately notify the District in writing. The District, Consultant and Contractor shall jointly establish the plan for disposition and actions to be taken with respect to the hazardous materials, subject to final written approval by the District.
- E. If, during construction, Contractor encounters materials, conditions, waste, contaminated groundwater or substances, not identified in the District's assessment report, that Contractor reasonably suspects are hazardous materials, Contractor shall stop the affected portion of the work, secure the area, promptly notify the District, and take reasonable measures to mitigate the impact of such work stoppage. The District

shall retain the services of an environmental consultant to perform investigation, inspection, testing, assessment, sampling and analysis of the suspect materials, conditions, waste, groundwater or substances.

- (1) Found Not to be Hazardous Materials. If the environmental consultant determines that the materials, conditions, waste, contaminated groundwater or substances do not constitute hazardous materials, Contractor shall recommence the suspended work.
- (2) Found to be Hazardous Materials. If the environmental consultant determines that the materials, conditions, waste, contaminated groundwater or substances constitute hazardous materials and such hazardous materials require remediation and disposal, then the District, Consultant and Contractor shall jointly establish the plan for disposition and actions to be taken with respect to the hazardous materials, subject to final written approval by the District. All such costs shall be the responsibility of the District.

F. Exacerbation of Pre-Existing Hazardous Materials.

If during construction Contractor encounters pre-existing environmental conditions that it knew or should have known involve hazardous materials (the "Point of Discovery") (which encounters may include an unavoidable release or releases of hazardous materials) then Contractor must immediately stop the affected portion of the work. If Contractor fails to immediately stop the affected portion of the work after the Point of Discovery, then Contractor is solely responsible for any resultant Exacerbation Cost. "Exacerbate," in all its forms, means the worsening effects of Contractor's failure to stop the affected portion of work after the Point of Discovery. "Exacerbation Cost" means the differential between (i) the actual increase in the cost of remediation and delays to the Project attributable to pre-existing environmental conditions involving hazardous substances, and (ii) the cost thereof or delays thereto had Contractor immediately stopped the affected portion of the work after the Point of Discovery. The standard of "should have known" applies to Contractor's supervisory personnel, whether or not on the Site. Contractor's supervisory personnel must have had the hazardous material training required by applicable OSHA and CalOSHA rules or regulations.

SECTION 20. INDEPENDENT CONTRACTOR

- A. Contractor is retained as an independent contractor and is not employed by the District. No employee or agent of Contractor shall become, or be considered to be, an employee of the District for any purpose. It is agreed that the District is interested only in the results obtained from service under this Agreement and that Contractor shall perform as an independent contractor with sole control of the manner and

means of performing the services required under this Agreement. Contractor shall complete this Agreement according to its own methods of work which shall be in the exclusive charge and control of Contractor and which shall not be subject to control or supervision by the District except as to results of the work. It is expressly understood and agreed that Contractor and its employees shall in no event be entitled to any benefits to which the District employees are entitled, including, but not limited to, overtime, retirement benefits, insurance, vacation, worker's compensation benefits, sick or injury leave or other benefits.

- B. Contractor shall be responsible for all salaries, payments, and benefits for all of its officers, agents, and employees in performing services pursuant to this Agreement.

SECTION 21. ACCOUNTING RECORDS

Contractor, and all Subcontractors, shall check all materials, equipment and labor entering into the work and shall keep or cause to be kept such full and detailed accounts as may be necessary for proper financial management under this Agreement, including true and complete books, records and accounts of all financial transactions in the course of their activities and operations related to the Project. These documents include sales slips, invoices, payrolls, personnel records, requests for Subcontractor payment, and other data relating to all matters covered by the Contract Documents (the "Data"). The Data shall be maintained for ten (10) years from the latest expiration of the term (as such may be extended) of any of the Contract Documents. Contractor shall use its best efforts to cause its Subcontractors to keep or cause to be kept true and complete books, records and accounts of all financial transactions in the course of its activities and operations related to the Project. Upon completion of the Project, Contractor shall provide the District with one (1) complete copy of the Data.

The District, at its own costs, shall have the right to review and audit, upon reasonable notice, the books and records of Contractor and any Subcontractors concerning any monies associated with the Project.

SECTION 22. PERSONAL LIABILITY

Neither the trustees, officers, employees, or agents of District, the District's representative, or Architect shall be personally responsible for any liability arising under the Contract Documents.

SECTION 23. AGREEMENT MODIFICATIONS

No waiver, alteration or modification of any of the provisions of this Agreement shall be binding upon either the District or Contractor unless the same shall be in writing and signed by both the District and Contractor.

SECTION 24. NOTICES

Any notices or filings required to be given or made under this Agreement shall be served, given or made in writing upon the District or Contractor, as the case may be, by personal delivery or registered mail (with a copy sent via fax or regular mail) to the respective addresses given below or at such other address as such party may provide in accordance with the provisions herein. Any change in the addresses noted herein shall not be binding upon the other party unless preceded by no less than thirty (30) days prior written notice.

If to Contractor:

Swinerton Builders
865 S. Figueroa Street
Suite 3000
Los Angeles, CA 90017

Attn: Bonnie Martin

If to the District:

Oxnard School District
1051 South A Street
Oxnard, California 93030

Attn: Dr. Cesar Morales, Superintendent

With a copy to Nitasha Sawhney,
Garcia, Hernandez, Sawhney & Bermudez LLP
1330 Broadway, Suite 1701
Oakland, CA 94612

And with an additional copy to Yuri Calderon,
Caldwell Flores Winters, Inc.
6425 Christie Ave., Suite 270
Emeryville, CA 94608

Notices under this Agreement shall be deemed to have been given, and shall be effective upon actual receipt by the other parties, or, if mailed, upon the earlier of the fifth (5th) day after mailing or actual receipt by the other party.

SECTION 25. ASSIGNMENT

Neither party to this Agreement shall assign this Agreement or sublet it as a whole without the written consent of the other, nor shall Contractor assign any monies due or to become due to it hereunder without the prior written consent of the District.

SECTION 26. PROVISIONS REQUIRED BY LAW

Each and every provision of law and clause required to be inserted in these Contract Documents shall be deemed to be inserted herein and the Contract Documents shall be read and enforced as though it were included herein, and if through mistake or otherwise any such provision is not inserted or is not inserted correctly, then upon application of either party the Contract Documents shall forthwith be physically amended to make such insertion or correction.

SECTION 27. HEADINGS

The headings in this Agreement are inserted only as a matter of convenience and reference and are not meant to define, limit or describe the scope or intent of the Contract Documents or in any way to affect the terms and provisions set forth herein.

SECTION 28. APPLICABLE LAW

This Agreement shall be governed by and construed in accordance with the laws of the State of California. The parties irrevocably agree that any action, suit or proceeding by or among the District and Contractor shall be brought in whichever of the Superior Courts of the State of California, Ventura County, or the Federal Court for the Central District of California in Los Angeles, California, has subject matter jurisdiction over the dispute and waive any objection that they may now or hereafter have regarding the choice of forum whether on personal jurisdiction, venue, forum non conveniens or on any other ground.

SECTION 29. SUCCESSION OF RIGHTS AND OBLIGATIONS

All rights and obligations under this Agreement shall inure to and be binding upon the successors and assigns of the parties hereto.

SECTION 30. NOTIFICATION OF THIRD PARTY CLAIMS

The District shall provide Contractor with timely notification of the receipt by the District of any third party claim relating to this Agreement, and the District may charge back to Contractor the cost of any such notification.

SECTION 31. SEVERABILITY

If any one or more of the terms, covenants or conditions of this Agreement shall to any extent be declared invalid, unenforceable, void or voidable for any reason whatsoever by a court of competent jurisdiction, the finding or order or decree of which becomes final, none of the remaining terms, provisions, covenants and conditions of the Contract Documents shall be affected thereby, and each provision of the Contract Documents shall be valid and enforceable to the fullest extent permitted by law.

SECTION 32. ENTIRE AGREEMENT

This Construction Services Agreement and the additional Contract Documents as defined in paragraph C of Section 1 herein, including the Site Lease, the Sublease, and the Specifications, drawings, and plans constitute the entire agreement between Contractor and the District. The Contract Documents shall not be amended, altered, changed, modified or terminated without the written consent of both parties hereto, except as otherwise provided in Section 10 hereof.

SECTION 33. EXECUTION IN COUNTERPARTS

This Agreement may be executed in any number of counterparts, each of which shall be an original, but all of which together shall constitute one instrument.

IN WITNESS WHEREOF the parties hereto, intending to be legally bound thereby, have executed this Agreement effective as of the date first above written.

CONTRACTOR

Swinerton Builders

By:  LIA TATEVOSIAN
Title: OPERATIONS MGR
Date: 4/6/16

THE DISTRICT

Oxnard School District,
a California school district

By:  Alan O'Malley
Title: District Superintendent
Date: April 26, 2016

EXHIBIT A

Scope of Work

The scope of Work for the Lemonwood Reconstruction Project consists of the construction of a new school, including a Kindergarten, Classroom, Administration and Multipurpose Building, as more specifically described in the DSA Approved plans, specifications and Construction Change Directives ("CCDs"). The following construction documents are referenced herein and incorporated into this contract for all purpose to more fully describe the scope of work contemplated and agreed to by the parties:

1. DSA Approved drawings for DSA Application # 03-116026.
2. DSA Approved Project Manual for DSA Application # 03-116026.
3. Addendum 01 dated 11/16/2015 for DSA Application # 03-116026 as issued to Swinerton Builders on 11/16/2015 by SVA Architects.
4. Addendum 02 dated 11/18/2015 for DSA Application # 03-116026 as issued to Swinerton Builders on 11/18/2015 by SVA Architects.
5. Addendum 03 dated 11/30/2015 for DSA Application # 03-116026 as issued to Swinerton Builders on 11/30/2015 SVA Architects.
6. Project Schedule prepared by Contractor and approved by Owner (Attached hereto).
7. Agreed Upon List of Qualifications (Attached hereto).
8. Pre-bid and Post-Bid Value Management Logs (Attached hereto).
9. Lemonwood GMP Qualification Matrix (Attached hereto).

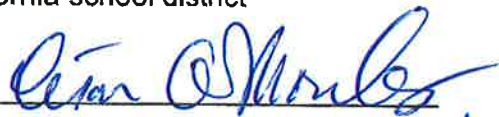
Regular Board Meeting
March 6, 2019

The Board of Trustees of the Oxnard School District met in regular session at 5:03 p.m. on Wednesday, March 6, 2019 at the Educational Service Center. CALL TO ORDER

A roll call of the Board was conducted. Present were President Veronica Robles-Solis and Trustees, Vega, O'Leary, Cordes and Madrigal Lopez. Staff members present were District Superintendent Dr. Cesar Morales, Assistant Superintendents Janet Penanhoat and Dr. Ana DeGenna, Dr. Jesus Vaca was absent, also present was Executive Assistant Rose Chaparro. ROLL CALL

Ms. Chantal Anderson-Witherspoon, Principal at Fremont Academy of Environmental Science & Innovative Design, introduced Jonathan Myers, 7th grade student in Mr. Reveles' class, who led the audience in the Pledge of Allegiance. PLEDGE OF ALLEGIANCE

Omaree Brown, 8th grade student in Ms. Madrid's class read the District's Vision and Mission Statements in English and Maria Nava Ceja, 7th grade student in Mr. Reveles' class, read them in Spanish. DISTRICT'S VISION AND MISSION STATEMENTS

Ms. Chantal Anderson-Witherspoon, Principal at Fremont Academy of Environmental Science & Innovative Design provided a presentation on the different programs, events and activities at Fremont. Ms. Anderson-Witherspoon highlighted the AVID and AVID EXCEL programs. A journalism student explained journalism activities on campus. Liana Valdez WEB president at Fremont spoke about this mentoring program. Student members spoke about their activities at ASB. They presented their antibullying calendars to the Board. Principal Anderson-Witherspoon introduced Mr. Blake Berriochoa, Counselor and Ms. Jazmin Garcia Clarke, ORC, from the Falcon Student Center. Two students spoke about the Falcon Student Center. Ms. Anderson-Witherspoon presented students who spoke about the programs, the electives in the various departments, the MESA Competition team, Drama, Art and Math Quest teams. Ms. Anderson-Witherspoon included in the presentation parent involvement opportunities, such as, Fremont PTA; Parent Project Parenting classes; High school A-G Parent Night; Latino Literacy Project Classes; AVID Family Nights; Incoming 6th grade Academy Tours; 6th Grade Welcome/Orientation Day; Coffee with the Principal meetings; Safety Presentation; Become a Parent Volunteer. PRESENTATION BY FREMONT ACADEMY OF ENVIRONMENTAL SCIENCE & INNOVATIVE DESIGN

Trustee Cordes presented a token of appreciation on behalf of the Board to the students that participated in the Board Meeting.

A.5 On motion by Trustee Cordes, seconded by Trustee Vega and carried on a roll call vote of 4-1, being Trustee O'Leary the no vote, the agenda was approved with the following amendments: ADOPTION OF THE AGENDA

- C.3 Approval of Field Contract # FC-P19-03693-Falcon Roofing Company: Revise the listed person(s)/department presenting the agenda report to the Board to reflect Janet Penanhoat, Assistant Superintendent of Business and Fiscal Services and David Fateh, Facilities Director as presenters and remove CFW. This project was managed by in-house facilities.

- Approve the following revisions to previously approved Board Meeting Minutes
 June 20, 2018 Regular Board Meeting:
 Second Reading of Board Policies, Administrative Regulations and Bylaws – Added Motion#17-162 to the record, as approved by the Board.
 August 22, 2018 Regular Board Meeting:
 Second Reading of Board Policies, Administrative Regulations and Bylaws – Added Motion#18-87 to the record, as approved by the Board.
- Correction to Board Member Attendance. Trustee Madrigal Lopez was present and attended the Special Board Meeting on February 13, 2019. Trustee Madrigal Lopez arrived at 5:30 pm. The board minutes as shown in the agenda were corrected.

A.6 Dr. Ana DeGenna, Assistant Superintendent of Educational Services introduced Ms. Anna Thomas, Director of Curriculum, Instruction and Accountability who presented the 37 students who had read over one million words. She pointed out that some of these students had read over the course of three years more than six, seven and eight million words in some cases.

RECOGNITION OF
 OXNARD SCHOOL
 DISTRICT’S MILLION
 WORD READERS

A.7 Dr. Ana DeGenna, Superintendent Assitant of Educational Services, introduced Ms. Noemi Valdez, Director Early Childhood Educational Programs who provided a presentation on the Early Childhood Educational Programs. The Oxnard School District offers a variety of early childhood education services for children and their families. These programs provide young children and their families with research-based strategies to prepare children and their families for kindergarten. The presentation focused on the various components of early education, recent changes to early education and their impact to district programming.

STUDY SESSION –
 EARLY CHILDHOOD
 EDUCATION
 PROGRAM

A.8 No one addressed the Board with comments on the closed session agenda.

PUBLIC COMMENT

ANNOUNCEMENTS PRIOR TO CLOSED SESSION March 6, 2019:
 The Board recessed to Closed Session to consider the following:

CLOSED SESSION

Firstly, for CONFERENCE WITH LEGAL COUNSEL under *Government Code*, Section 54956.9:

- ANTICIPATED LITIGATION: one (1) case
- EXISTING LITIGATIONS: Existing Litigations: two (2) cases
 - Office of Administrative Services OAH Case No.: 2019-01-0346
 - J.R. v. Oxnard School District et al. Central District No. CV-04304-JAK-FFM

Secondly, for CONFERENCE WITH LABOR NEGOTIATORS under *Government Code*, Sections 54957.6 and 3549.1.

The District negotiator is the Assistant Superintendent, Human Resources & Support Services, and Garcia Hernandez & Sawhney, LLP, the employee organizations are OEA, OSSA, CSEA; and all unrepresented personnel – administrators, classified management, confidential.

Lastly, PUBLIC EMPLOYEE(S) DISCIPLINE/DISMISSAL/RELEASE, under *Government Code*, Section 54957 and *Education Code*, Section 44943:

- a. Public Employee(s) Discipline/Dismissal/Release
- b. Reassignment, Appointment

Trustees convened to closed session at 6:24 p.m. until approximately 7:15 p.m. to discuss items on the closed session agenda. REPORT ON CLOSED SESSION

President Robles-Solis reported the agreement on the Office Administrative Services OAH case No.: 2019-01-0346 was approved on a motion by Trustee O’Leary, seconded by Trustee Cordes and carried on a roll call vote of 5-0. (Motion# 18-103)

A.12 Dr. Ana DeGenna, Assistant Superintendent of Educational Services introduced Ms. Anna Thomas, Director of Curriculum, Instruction and Accountability who provided a presentation on the AVID Program in the Oxnard School District Schools and Dr. Marlene Batista who provided a presentation on AVID Excel. STUDY SESSION
PRESENTATION ON
THE AVID PROGRAM

Trustee Madrigal Lopez read the rules for Individual Participation in English and Spanish. PUBLIC COMMENTS

- No one addressed the Board.

On motion by Trustee Madrigal Lopez, seconded by Trustee Cordes and carried on a roll call vote of 5-0; the consent agenda was approved as amended. CONSENT AGENDA
(Motion#18-104)

- C.3 Approval of Field Contract # FC-P19-03693-Falcon Roofing Company: Revise the listed person(s)/department presenting the agenda report to the Board to reflect Janet Penanhoat, Assistant Superintendent of Business and Fiscal Services and David Fateh, Facilities Director as presenters and remove CFW. This projet was managed by in-house facilities.

C.1 Accepted the following gifts: (Acceptance of Gifts)

- From Stacie Thurman, OEA President, on behalf of the OEA, a donation to Sierra Linda School of two books, the Toy Academy, Some Assembly Required and Space Cows, in time for the upcoming Read Across America event and Dr. Seuss’ Birthday events.

C.2 Approved the Assignment and Assumption Agreements with Bernards Bros., Inc. for the Elm, Marshall and McKinna School projects. Pursuant to California Education Code § 17406, Oxnard School District entered into three separate lease-leaseback-agreements with Bernards Bros., Inc. with respect to the construction of improvements at the following schools: Elm Elementary School, Marshall Elementary School, and McKinna Elementary School. (Approval of Assignment Agreements with Bernards Bros. Inc. for the Elm (#18-213), Marshall (#18-214) and McKinna School (#18-215) Projects (Penanhoat/Fateh/CFW))

C.3 Approved the award of Field Contract #FC-P19-03693 to the lowest responsible bidder, Falcon Roofing Company in the amount of \$57,984.00. The project will be funded through Deferred Maintenance Fund. (Approval of Field Contract # FC – P19-030693 – Falcon Roofing Company)

- C.4 Ratified Change Order No. 003 to Construction Services Agreement #17-212 with Viola Constructors Inc., amount not to exceed \$13,768.04, to be paid out of the Master Construct and Implementation Funds. Change Order No. 003 consists of two (2) change order requests from Viola Constructors Inc., to adjust costs for the Kinder/Flex project at McAuliffe Elementary School. Change Order No. 003 provides for the Board’s consideration and ratification of two (2) change order requests: PCO #007 for School Entry Accessibility Upgrades and PCO #008 for Credit Unused allowances. (Ratification of Change Order No. 003 to Construction Services Agreement #17-212 with Viola Constructors Inc. to Adjust Costs for the Kinder/Flex project at McAuliffe Elementary School)
- C.5 Ratified the increase to the overall project budget approving the allocation of \$3,059.69 from the Program Reserve of the Master Construct and Implementation Program, which will be reflected in the next Semi-Annual Update to the Master Construct & Implementation Program Report. A revision to the placement of metal plates embedded into the building’s concrete foundation was required to accommodate the welding of the modular units that anchor the building to the foundation. The discrepancy was discovered after the foundation was poured and required additional engineering work and the submission of a revised design to the Division of the State Architect. All other costs to make this revision and correction are being borne by the Contractor doing the site work for the project. Change Order No. 003 provides for the Board’s consideration and ratification of one (1) owner change order request; PCO #003 with the following scope of work: PCO #003 – Engineering for Weld Plate Revision. (Ratification of Change Order #003 to PO #P18-03889 with Silver Creek Industries Inc. to Adjust Costs for the Kinder/Flex Project at Ramona Elementary School)
- C.6 Reviewed and accepted the 2018-2019 2nd Quarter Williams VCOE Activity Report, as presented. Education Code Section 1240(c)(2)(C) requires that the County Superintendent report the results of any Williams Lawsuit Settlement visits, on a quarterly basis, to the Governing Boards of districts with deciles 1 to 3 schools. The attached report reflects the Ventura County Office of Education’s Williams-related visits and activities completed during the 2nd quarter of fiscal year 2018-2019. (2018-2019 2nd Quarter Williams VCOE Activity Report)
- C.7 Rejected York claim VCBA08300A2. (Rejection of Liability Claim: VCBA08300A2)
- C.8 Approved the increase of positions as follows: (Establish/ Abolish/ Increase/ Reduce Hours of Position)
- A five hour 194 day Campus Assistant position number 3013 to be increased to five hours thirty minutes at Marina West School. This position will be increased to provide additional support.
- A five hour 194 day Campus Assistant position number 3014 to be increased to five hours thirty minutes at Marina West School. This position will be increased to provide additional support.
- A five hour 194 day Campus Assistant position number 3015 to be increased to five hours thirty minutes at Marina West School. This position will be increased to provide additional support.
- A five hour 194 day Campus Assistant position number 3016 to be increased to five hours thirty minutes at Marina West School. This position will be increased to provide additional support.

A three hour 194 day Campus Assistant position number 8654 to be increased to four hours at Marina West School. This position will be increased to provide additional support.

C.9 Approved the Personnel Actions, as presented. (Personnel Actions)

The following classified individuals to be employed in the capacities and for the terms indicated, their salaries to be determined in accordance with salary regulations of the district, it being understood that substitute classified personnel and regular classified personnel performing substitute duties will be assigned by the administration and paid in accordance with salary regulations governing the specific assignment: (Classified)

<u>Name</u>	<u>Position</u>	<u>Effective Date</u>
<u>New Hire</u>		
Alonzo, Teresa	LanguageAssesment Technician, position #2443 English Learner Services 5.5 Hours / 246 days	0/11/2019
<u>Limited Term</u>		
Cordova, Veronica	Paraeducator	02/05/19
<u>Resignation</u>		
Leyva Leonor Oralia	Senior Human Resources Analyst, Position #6298 Personnel Commission 8 hrs /261 days	02/07/19

E.1 On Motion by Trustee O’Leary, seconded by Trustee Madrigal Lopez and carried on a roll call vote of 5-0, the Board approved the minutes of regular and special board meetings, as submitted: (Motion # 18-105)

- February 6, 2019, Regular Board Meeting
- February 13, 2019, Special Board Meeting
- February 20,2019, Regular Board Meeting

G.1 Superintendent Announcements:

Dr. Cesar Morales

- Highlighted the activities for Read Across America Day and showed some pictures of the events.
- Congratulated President Robles-Solis and Former Trustee Ernest Morrison for the Meritorious Service Award received from the Ventura County School Board Association.
- Congratulated Isabella G. from Juan Soria for winning 1st place in the 2nd annual District Spelling Bee. She will compete in the Ventura County Spelling Bee.
- Thanked the students that competed in the 37th Annual African American Speech Expo. Congratulated Arandi R. for winning 1st place. She will have the opportunity

to present her speech at the Annual Martin Luther King Day Parade, in January 2020.

- Reminded everyone is invited to the Elm School Grand Opening on March 9 at 10 a.m.
- Addressed the comments regarding the DLI program at Haydock:
6th grade DLI will have two periods of Spanish: Spanish Language Arts and Social Studies taught by a BCLAD, multiple subject teacher. As it moves up, 7th grade will consist of one period of Spanish taught by a teacher with Spanish credentials. 8th grade will consist of 1 period of Spanish taught by a teacher with Spanish credentials.
The DLI expansion of this year will be exclusively for Haydock.

Trustee Cordes:

- Clarified the reasons for her vote on Plaza Comunitaria. First, she feels this is a high school function; second, it has been offered in the past and has not been well attended, third and most important is the financial part, Ms. Cordes stated that she did not want to add to the expenses, to cut 10 million in the next meeting.
- Attended the Spelling Bee and the African American Speech Expo. Thanked parents, teachers and principals for supporting students.
- Reported she visited several schools and has a couple more to go.
- Congratulated President Robles-Solis and former trustee Ernest Morrison for the award received at CSBA.
- Reported that the following Tuesday they would be attending Legislative Action Day in Sacramento lobbying for the students.

TRUSTEES ANNOUNCEMENTS

Trustee Vega

- Expressed he had a great time at the Spelling Bee and the African American Speech Competition. They were inspiring.
- Thanked Ms. Ayala for inviting him to her class. He had a great time.

Trustee O'Leary

- Reported that on February 25 he was invited by the Mexican Consulate in Los Angeles to meet the Minister of Education of Mexico Mr. Aurelio Nuño Mayer. He also met with the leaders that are implementing Plaza Comunitaria and with Gabriela Perez from CABE who will act as the liaison.
- Reported that on February 28 met with the Homeowners Association of Westport. They are next to the Seabridge site. They say they have questions and concerns.
- Requested a vote on a project labor agreement policy for future projects.
- Requested an organizational plan to rotate the Board Presidency, to be equitable to constituents.

Trustee Madrigal Lopez

- Expressed she is looking forward to attending Elm Grand Opening the following Saturday.
- Reported she attended two of the High School and Beyond events at Brekke and Lemonwood and she is attending a couple more.

President Robles-Solis

- Reminded that there was a Board Retreat on March 13th.
- Reported she attended the African American Speech Expo and congratulated the winners.
- Expressed she is looking forward to attend Elm Grand Opening.
- Reminded Board Members the Board Governance event in Santa Barbara.
- Enjoyed the Fremont presentation.

There being no further business, on motion by Trustee Cordes, seconded by Trustee Vega and carried on a roll call vote of 5-0, the Board of Trustees adjourned the meeting at 8:22 p.m.

Respectfully Submitted,
DR. CESAR MORALES

District Superintendent and
Secretary to the Board of Trustees

By our signature below, given on this _____ day of _____, 20____, the Governing Board of the Oxnard School District approves the Minutes of the Regular Board meeting of March 6, 2019, on motion by Trustee _____, seconded by Trustee _____.

Signed:

President of the Board of Trustees

Clerk of the Board of Trustees

Member of the Board of Trustees

Member of the Board of Trustees

Member of the Board of Trustee

Regular Board Meeting
March 20, 2019

The Board of Trustees of the Oxnard School District met in regular session at 5:03 p.m. on Wednesday, March 20, 2019 at the Educational Service Center. CALL TO ORDER

A roll call of the Board was conducted. Present were President Veronica Robles-Solis and Trustees, Jesus Vega, Denis O’Leary, Debra Cordes and Monica Madrigal Lopez. Staff members present were District Superintendent Dr. Cesar Morales, Assistant Superintendents Janet Penanhoat, Dr. Ana DeGenna and Dr. Jesus Vaca, and Executive Assistant Rose Chaparro. ROLL CALL

Ms. Allison Cordes, Principal at Norma Harrington School, Academy of Environmental Sciences and the Arts, introduced Jayden Melton, 5th grade student in Ms. Young’s class, who led the audience in the Pledge of Allegiance. PLEDGE OF ALLEGIANCE

Daniel Calderon, 5th grade student in Ms. Young’s class read the District’s Vision and Mission Statements in English and Joel Mondragon, 4th grade student in Mrs. Michling’s class read them in Spanish. DISTRICT’S VISION AND MISSION STATEMENTS

Principal Allison Cordes provided a short presentation to the Board regarding Norma Harrington Academy of Environmental Sciences and the Arts. A group of students from kindergarten and 3rd grade from the DLI program performed for the Board. Following, Maria Lopez a 4th grade student in Ms. Madrona’s class shared her perspective on being a student at Harrington. Ms. Cordes congratulated Jayden Melton and Daniel Calderon for winning 1st and 2nd place in the Math Competition. Principal Cordes highlighted the activities to support parent engagement and empowerment, and shared the activities that took place for the Read Across America Day, activities with Community Partners and the Math Competition. Finally, Ms. Cordes highlighted the academic focus on the various disciplines and commented on future plans. PRESENTATION BY NORMA HARRINGTON ACADEMY OF ENVIRONMENTAL SCIENCES AND THE ARTS
Following the presentation, President Robles-Solis presented a token of appreciation to the students that participated in the Board Meeting.

On motion by Trustee Cordes, seconded by Trustee Madrigal Lopez and carried on a roll call vote of 4-1; being Trustee O’Leary the No vote, the agenda was approved as presented. ADOPTION OF THE AGENDA

A.7 Dr. Ana DeGenna, Assistant Superintendent of Educational Services introduced Ms. Ginger Shea, Director of Afterschool Programs who presented the Million Readers from Harrington, Lemonwood, Marina West and Marshall. The Principals of each school read the names of the students recognized. RECOGNITION OF OXNARD SCHOOL DISTRICT’S MILLION WORD READERS

A.6 Dr. DeGenna, Assistant Superintendent of Educational Services introduced Ms. Ana Thomas, Director of Curriculum, Instruction and Accountability and Mrs. Aracelli Fox, Director of Dual Language Programs who provided an accountability update on local measures used to monitor teaching and learning in the Oxnard School District. These assessments include STAR 360, Smarter Balanced Interim assessment blocks, and site-based assessment. STUDY SESSION – EL ROADMAP PRESENTATION

A.8 Trustee Madrigal Lopez read the Rules for Individual Participation in English and Spanish. PUBLIC PARTICIPATION

- Josephine Noyola, thanked Ms. Cordes and Mondragon for their help and support and addressed IT hour cuts at Harrington School.

ANNOUNCEMENTS PRIOR TO CLOSED SESSION March 20, 2019: CLOSED SESSION
After public comments on the closed session items, the Board recessed to Closed Session to consider the following:

Firstly, for CONFERENCE WITH LEGAL COUNSEL under *Government Code*,

Section 54956.9:

- ANTICIPATED LITIGATION: one (1) case
- EXISTING LITIGATIONS:
 - Office of Administrative Services Case No.: 2016-10-053
 - J.R. v. Oxnard School District et al. Central District No. CV-04304-JAK-FFM

Secondly, REMOVAL/SUSPENSION/EXPULSION OF STUDENTS (*Education Code 8912; 20 U.S.C. Section 1232g*):

- Case No. 18-04 (Action Item)
- Case No. 18-05 (Action Item)
- Case No. 18-06 (Action Item)
- Case No. 18-07 (Action Item)
- Case No. 18-08 (Action Item)
- Case No. 18-09 (Action Item)

Thirdly, for CONFERENCE WITH LABOR NEGOTIATORS under *Government Code*, Sections 54957.6 and 3549.1.

The District negotiator is the Assistant Superintendent, Human Resources & Support Services, and Garcia Hernandez & Sawhney, LLP, the employee organizations are OEA, OSSA, CSEA; and all unrepresented personnel – administrators, classified management, confidential.

Lastly, PUBLIC EMPLOYEE(S) DISCIPLINE/DISMISSAL/RELEASE, under *Government Code*, Section 54957 and *Education Code*, Section 44943:

- Public Employee(s) Discipline/Dismissal/Release.
- Reassignment, Appointment:

Trustees convened to closed session at 6:16 p.m. until approximately 7:07 p.m. to discuss items on the closed session agenda. CLOSURE SESSION

President Robles-Solis informed there was nothing to report and that the Board would return later to closed session. REPORT ON CLOSURE SESSION

A.12 Ms. Janet Penanhoat, Superintendent of Business and Fiscal Services provided a presentation on Living Wage. LIVING WAGE REPORT

B.1 Trustee Madrigal Lopez read the rules for individual participation in English and in Spanish. PUBLIC COMMENTS

- Arnett Smithson, concerned about the reduction in force and lack of appreciation for teachers.
- Natalia Vedernikova, donated her time to Arnett Smithson.
- Joseph Chiong, donated her time to Arnett Smithson.
- Shawna Wagoff, donated her time to Arnett Smithson.
- Monica Centeno, spoke on behalf of K-5, K-8 and 6-8 librarians and media techs hours reduction.
- Veronica Gutierrez, donated her time to Monica Centeno.
- Brenda Ruckstuhl, spoke on behalf of library media technicians.
- Yolanda Moss, donated her time to Brenda Ruckstuhl
- Susana Gurrola, concerned about library technicians and technology positions.
- Alex Cardona, not available.
- Dave Rodriguez, spoke to support teachers and classified staff on behalf of LULAC.
- Monserrat Hernandez, opposed to the elimination of positions.
- Maritza Gutierrez, ORC hours reduction
- Reyna Moreno, donated her time to Maritza Gutierrez.
- Petula Rodriguez, ORC hours reduction.
- Monica Arias Melgoza, donated her time to Petula Rodriguez.
- Janet S. Piña, donated her time to Petula Rodriguez.
- Teresa Vasquez, concerned about the ORC reduction in hours.
- Ana Medina, donated her time to Teresa Vasquez.
- Jessica Alcantar, donated her time to Teresa Vasquez.
- Gabby Serrano donated her time to Teresa Vasquez.
- Ocil Herrejon, concerned about the reduction in force.
- Rakena James, concerned about the librarians hours cut.
- Maritza Avila, concerned about the lack of respect for teachers.
- Karen sher, donated her time to Maritza Avila.
- Lucy Cartagena, concerned about the reduction in force.
- Efrain Cazares, opposed to resolution #18-30.
- Marie Ambriz donated her time to Efrain Cazares.
- Ilene Poland, concerned about the classified and certificated staff cuts.
- Roderick Warwick, concerned about the site tech hours cuts.
- Maria Elena Cruz, from LULAC, teacher and staff cuts.
- David Cruz, concerned about teacher and staff cuts.
- Luz Chavez, concerned about cuts.
- Gricette Renteria, concerned about cut.
- Jeremy Meyer, from CAUSE, concerned about the proposed cuts of staff.

- Rosita Lopez, hours reduction.

On motion by Trustee Cordes, seconded by Trustee Madrigal Lopez and carried on a roll call vote of 5-0, the consent agenda was approved as presented.

CONSENT AGENDA
(Motion# 18-106)

C.1 Accepted the following gifts:

(Acceptance of Gifts)

- From Oxnard Educators Association, a donation of two to three new hardcover books to each school library in the Oxnard School District in honor of Read Across America 2019. Several individual classroom libraries also received a special book that was read to students on that day. As teachers, we believe that reading is a joyous experience that broadens the horizons and enriches the lives of our students. The teachers of the Oxnard School District were delighted to spend approximately \$1,200.00 for this donation of books.
- From Oxnard Educators Association, a donation of books to the Marina West Library. This has become a tradition for the OEA during Read Across America. Their donation will contribute to both non-fiction and fiction collections at the Marina West Library.

C.2 Approved the following agreements:

(Approval of Agreements)

Enrichment:

- #18-221 – Art Trek Inc. to provide student activities during the Saber es Poder – English Learner Parent Conference at Frank School on Saturday, March 30, 2019, amount not to exceed \$3,000.00, to be paid from Title III funds.

C.3 Ratified the following agreements:

(Ratification of Agreements)

Academic:

- Ratification of Agreement/MOU #18-220 – Ventura County Office of Education. The Ventura County Office of Education (VCOE) will work with Oxnard School District (OSD) to improve career and technical education services to the middle schools in the district through the California Department of Education Career Technical Education Incentive Grant and the California Career Pathways Trust Grant. OSD will receive up to \$4,000.00 at each site. Funds may be used to purchase curriculum or instructional materials that focus on a career pathway and on equipment needed to upgrade existing programs, or new equipment to start a career pathway program. Each site will provide a proportional dollar-for-dollar match for any funding received.

C.4 Approved Amendment #1 to Agreement #18-18 with the Center for Teaching for Biliteracy; amount not to exceed \$6,600.00, to be paid with Title I funds. At the Board meeting of June 20, 2018, the Board of Trustees ratified Agreement #18-18 with Karen A Beeman, dba/Center for Teaching for Biliteracy to provide professional development in Dual Language to District administration, teachers and staff during the 2018-2019 school year for \$107,000.00. Amendment #1, for \$6,600.00, is required in order to stay on schedule with the curriculum rollout and add an extra day of training. This brings the total agreement amount to \$113,600.00 for the 2018-19 school year.

(Approval of Amendment #1 to Agreement #18-18 – Center for Teaching for Biliteracy)

- C.5 Set the date of Wednesday, April 3, 2019, for a public hearing on the Oxnard School District 2019 School Facilities Needs Analysis Report. (Setting of Date for Public Hearing – School Facilities Needs Analysis)
- C.6 District enrollment as of February 28, 2019 was 16,175. This is 437 less than the same time last year. (Enrollment Report)
- C.7 Approved Purchase Order/Draft Payment Report #18-08, as submitted. (Purchase Order/Draft Payment Report #18-08)
- C.8 Approved the Overnight Field Trip and Agreement #18-219 with Camp Whittier, at no cost to the district. No impact to the General Fund. 6th grade students from Chavez School will attend this trip from May 28-31, 2019. (Approval of overnight Field Trip and Agreement #18-219 – Camp Whittier)
- C.9 Approved the revised 2018-19 Quarterly Report on Williams Uniform Complaint, first quarter, as presented. (Approval of Revised 2018-19 Quarterly Report on Williams Uniform Complaints. First Quarter)
- C.10 Approved the personnel actions, as presented. (Personnel Actions)

The following classified individuals to be employed in the capacities and for the terms indicated, their salaries to be determined in accordance with salary regulations of the district, it being understood that substitute classified personnel and regular classified personnel performing substitute duties will be assigned by the administration and paid in accordance with salary regulations governing the specific assignment:

<u>Name</u>	<u>Position</u>	<u>Effective Date</u>
<u>Leave of Absence</u>		
Rodriguez, Raquel	Outreach Specialist, Position #2614 Rose Avenue School, 8 hrs, 180 days	03/01/19 – 06/15/19
Mendez, Yessica	Paraeducator III, Position #1001 San Miguel School, 5.75 hrs, 183 days	1/23/19 - 5/23/19 Wednesdays only
<u>New Hire</u>		
Arroyo Hernandez, Maria I.	District Translator, Position #7259 Special Education, 8 hrs, 12 months	03/18/2019
Burciaga Jr, Heraclio L.	Campus Assistant, Position #9142 Driffill School, 2 hrs, 180 days	09/21/2019
Cortez, Angela G.	Campus Assistant, Position #2987	02/19/2019

Robles, Lisette	Frank School, 5.75 hrs, 180 days Outreach Specialist, Position #2200 Kamala School, 8 hrs, 180 days	02/27/2019
<u>Promotion</u>		
Jindal, Shweta	Payroll Technician, Position #9175 Budget & Finance, 8 hrs, 12 months Accounting Specialist III, Position #846 Budget & Finance, 8 hrs, 12 months	02/19/2019
Marquez, Juana A.	Senior Payroll Technician, Position #9178 Budget & Finance, 8 hrs, 12 months Accounting Specialist IV, Position #1747 Budget & Finance, 8 hrs, 12 months	02/19/2019
Cooper, John W.	Senior Manager, Maintenance & Operations, Position #1082 Facilities, 8 hrs, 12 months Grounds Manager, Position #7423 Facilities, 8 hrs, 12 months	03/01/2019
<u>Increase in Hours</u>		
Lopez C, Victor F.	Campus Assistant, Position #6546 Driffill School, 5.75 hrs, 180 days Campus Assistant, Position #7901 Driffill School, 4.75 hrs, 180 days	09/19/2018
<u>Resignation</u>		
Lumbrano, Angie	Paraeducator I, Position #7184 McAuliffe School, 4.83 hrs, 183 days	03/01/2019
<u>Termination</u>		
Employee ID #8331	Campus Assistant, Position #7874 Chavez School, 3 hrs, 180 days	01/19/2019

Listed below are recommended Certificated Personnel Actions presented to the Board of Trustees for consideration. The salaries for the individuals employed will be determined, in accordance with the salary regulations of the District. (Certificated)

<u>Name</u>	<u>Position</u>	<u>Effective Date</u>
<u>New hires</u>		
Banuelos-Finn, Ana	Substitute Teacher	2018/2019 School Year
Braziel, Lorelei	Substitute Teacher	2018/2019 School Year
Evans, Denise	Substitute Teacher	2018/2019 School Year
Farrell, Jennifer	Substitute Teacher	2018/2019 School Year
Lumbrano, Angie	Substitute Teacher	2018/2019 School Year

Means, Ruth	Substitute Teacher	2018/2019 School Year
Padilla, Amanda	Substitute Teacher	2018/2019 School Year
Villanueva, Kenneth	Substitute Teacher	2018/2019 School Year

Intervention Services Provider
(less than 20 hours per week
not to exceed 75% or 135
days a year

Jacobs, Deborah	ISP, Fremont	03/04/2019
-----------------	--------------	------------

Resignations

Johnson, Alison	M/M Teacher, Marina West	06/14/2019
-----------------	--------------------------	------------

Retirement

Vocke, Eileen	Speech Therapist, San Miguel	06/14/2019
---------------	------------------------------	------------

Leave of Absence

Fedele, Joy	Teacher, Fremont	03/12-6/14/2019
-------------	------------------	-----------------

D.1 On motion by Trustee Cordes, seconded by Trustee Vega and carried on a roll call vote of 5-0, the Board accepted the 2018-19 Second Interim Report as presented, and authorized the filing of a Positive Certification with the Ventura County Office of Education. 2018-19 SECOND INTERIM REPORT (Motion #18-107)

D.2 On Motion by Trustee Madrigal Lopez, seconded by Trustee Cordes and carried on a roll call vote of 4-1, being Trustee O’Leary the No vote, the Board adopted Resolution #18-30 to eliminate/reduce classified positions, as presented. REDUCTION IN FORCE: APPROVAL OF RESOLUTION #18-30 TO ELIMINATE/ REDUCE CLASSIFIED POSITIONS (Motion #18-108)

G.1 Superintendent Announcements: SUPERINTENDENT ANNOUNCEMENTS

Dr. Cesar Morales

- Pointed out that the decisions made that day were hard but expenditures had been exceeding revenues and the budget had been pushed to the limit. He expressed that the administration had tried to make the best out of the budget. The current year, five million were cut without affecting employees. Next year, nine million would need to be cut and it is important to say that the administration would try to do it

with the least amount of impact possible but is impossible not to affect some people. Over the next three years, the administration needs to identify eight million on cuts.

- Indicated that every year in May when the Governor the Legislature release a one-time adjustment to the budget, the budget is corrected before its ultimate approval in June.
- Stated that over the last six years, the district was able to implement grade span adjustments to TK, K and 1st grade. Next year this will extend to 2nd and 3rd grades. Also added that over the last six years salaries for teachers and classified personnel had improved.
- Stated that enrollment had decreased and projected housing projects the district was counting on for enrollment had not been approved or were not moving forward.
- He indicated that new schools are necessary. The district had still the equivalent of 4-5 school worth of portables. Declining of enrollment and construction of new schools would help eliminate sooner portables and provide quality facilities for students.
- Indicated that the district had worked hard to maintain support services. The OSD had fought hard to avoid cuts and had done that for some years but could not continue.
- Added that anything beyond the 3% is assigned for books, and has to be used for that effect.
- Indicated that the budget had been decentralized and Schools Sites had a big portion of the budget. According to the LCFF all schools had funding over which they could make decisions and prioritize, and maybe cover some of the services reduced.
- Indicated that even though the administration had worked hard to try to create scenarios to maximize the services for students, it was time to present the Second Interim Report to the Board. After its approval, the budget had to be presented to the county, in order to get a positive certification as a solvent district able to continue making its own decisions.
- Stated that afterwards, there could be possible changes in relation to funding and expending. Indicated that day the district had tighten the belt. Perhaps at the end of the year this could improve the situation. He added that if in the coming meetings there is any way to look at the restricted side of the budget, maybe the district would be able to revert the reductions implemented.
- Expressed that he hopes the state responds to the advocacy for more funding. Indicated that funding must be equalized and that funding for Special Education is needed.
- Indicated there is a conflict between the administration and the members of the community and those impacted.
- Explained that other large school districts in the state are having the same problems.
- Assured that the OSD administrators will work tirelessly to offer the best scenario before the end of this school year or the beginning of the next year.
- Clarified that these decisions are not taken lightly and it is unfortunate that the District is at that point that has to make them.

G.2 Trustees Announcements:

TRUSTEES ANNOUNCEMENTS

Trustee Cordes:

- Stated that cuts are not good for the community and employees but decisions had to be made.
- Reported she was glad that Read Across America events took place in different days so she could attend to more schools.
- Reported she attended the Math competitions at Fremont.

- Reported she attended Elm Grand Opening.
- Reported she attended Career Day at Frank.
- Reported she attended the Legislative Action Day to advocate for funding for districts.
- Thanked for the opportunity to work for the district

Trustee Vega

- Commented that decisions made that day were hard.

Trustee O’Leary

- Invited everyone on Sunday to attend the march to celebrate the life and legacy of Cesar Chavez. The event would start at 10:00 a.m. at Cesar Chavez School. Around 11:00 am. the march would head to la Placita after crossing the bridge over 3rd St. This year the march would be especially important because Teresa Romero the new President of the United Farm Workers, who replaced Mr. Arturo Rodriguez, retired in December, would attend the march.

Trustee Madrigal Lopez

- Stated that the decisions taken that day were hard but they were in the best interest of the children.
- Thanked teachers, librarians, campus assistants and all who work with children.
- Reported she attended Elm Grand Opening.
- Reported following week attended the performance of the Haydock Drama Club.
- Attended the After High School and Beyond events and thanked Ms. Shea for her work making everyone aware of the importance of the A-G requirements.

President Robles-Solis

- Reported she attended Career Day at Frank
- Reported she attended Elm Grand Opening.
- Commented that the decisions taken that day were hard but they were necessary.

At 10:13 p.m., the Board reconvened to closed session until approximately 10:54 p.m. to discuss items in the closed session agenda. **CLOSED SESSION**

President Robles-Solis reported actions taken in closed session.

REPORT ON CLOSED SESSION

On motion by Trustee Cordes, seconded by Trustee O’Leary, and carried on a roll call vote of 4-0, being Trustee Madrigal Lopez absent, the Board approved the settlement for Office of Administrative Case# OAH 2016-10-053 (Motion #18-109)

Removal/Suspension/Expulsion Of Students:

On motion by Trustee O’Leary, seconded by Trustee Cordes and carried on a roll call vote of 4-0, being Trustee Madrigal Lopez absent, the Board approved the administration recommendation in Case # 18-04. (Motion #18-110)

On motion by Trustee Cordes, seconded by Trustee O’Leary and carried on a roll call vote of 4-0, being Trustee Madrigal Lopez absent, the Board approved the administration recommendation in Case # 18-05. (Motion #18-111)

On motion by Trustee Cordes, seconded by Trustee Vega and carried on a roll call vote of 2-2, being Trustee O’Leary and Trustee Robles-Solis the No votes, and Trustee Madrigal Lopez Absent, the Board did not approve the administration recommendation in Case # 18-06. (Motion #18-112)

On motion by Trustee Cordes, seconded by Trustee Vega and carried on a roll call vote of 4-0, being Trustee Madrigal Lopez absent, the Board approved the administration recommendation in Case # 18-07. (Motion #18-113)

On motion by Trustee Cordes, seconded by Trustee O’Leary and carried on a roll call vote of 4-0, being Trustee Madrigal Lopez absent, the Board approved the administration recommendation in Case # 18-08. (Motion #18-114)

On motion by Trustee O’Leary, seconded by Trustee Vega and carried on a roll call vote of 4-0, being Trustee Madrigal Lopez absent, the Board approved the administration recommendation in Case # 18-09. (Motion #18-115)

There being no further business, on motion by Trustee Vega, seconded by Trustee Cordes and carried on a roll call vote of 4-0, being Trustee Madrigal Lopez absent, the Board of Trustees adjourned the meeting at 10:12 p.m.

Respectfully Submitted,
DR. CESAR MORALES

District Superintendent and
Secretary to the Board of Trustees

By our signature below, given on this _____ day of _____, 20____, the Governing Board of the Oxnard School District approves the Minutes of the Regular Board meeting of March 20, 2019, on motion by Trustee _____, seconded by Trustee _____.

Signed:

President of the Board of Trustees

Clerk of the Board of Trustees

Member of the Board of Trustees

Member of the Board of Trustees

Member of the Board of Trustees



OXNARD SCHOOL DISTRICT

1051 South “A” Street • Oxnard, California 93030 • 805/385-1501

SCHEDULE OF BOARD MEETINGS JANUARY – DECEMBER 2019

(UNLESS OTHERWISE INDICATED, ALL MEETINGS ARE HELD ON THE FIRST AND THIRD **WEDNESDAY** OF EACH MONTH IN THE BOARD ROOM AT THE DISTRICT OFFICE, 1051 SOUTH ‘A’ STREET, STARTING AT 7:00 PM)

January	16	Regular Board Meeting (Note: only ONE meeting in January)
February	6	Regular Board Meeting
	20	Regular Board Meeting
March	6	Regular Board Meeting
	20	Regular Board Meeting
April	3	Regular Board Meeting (Note: only ONE meeting in April)
May	1	Regular Board Meeting
	15	Regular Board Meeting
June	5	Regular Board Meeting
	19	Regular Board Meeting
July		District Dark – No meeting in July
August	7	Regular Board Meeting
	21	Regular Board Meeting
September	4	Regular Board Meeting
	18	Regular Board Meeting
October	9	Regular Board Meeting
	23	Regular Board Meeting
November	13	Regular Board Meeting (Note: only ONE meeting in November)
December	11	Regular Board Meeting – Organizational Meeting of the Board (Note: only ONE meeting in December)

The meeting schedule shown above is subject to change at any time.

NOTE: Changes are indicated in italics/bold.

Spring Break: April 8 - 19, 2019

Last Day of School 2018-19: June 14, 2019

First Day of School 2019-20: August 21, 2019

Board Approved: 12-12-18

Mission: “Ensure a culturally diverse education for each student in a safe, healthy and supportive environment that prepares students for college and career opportunities.”