

OXNARD SCHOOL DISTRICT

1051 South "A" Street • Oxnard, California 93030 • 805/385-1501

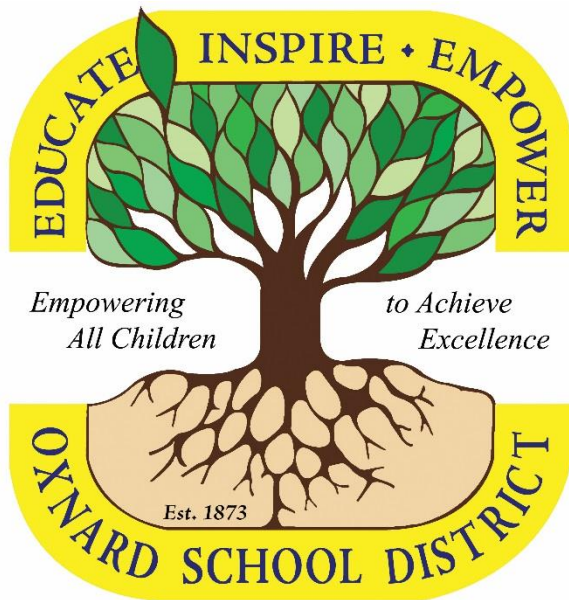

BOARD OF TRUSTEES

Mrs. Debra M. Cordes, President
Mr. Ernest "Mo" Morrison, Clerk
Mr. Denis O'Leary, Member
Mrs. Veronica Robles-Solis, Member
Ms. Monica Madrigal Lopez, Member

ADMINISTRATION

Dr. Cesar Morales
District Superintendent
Mrs. Janet C. Penanhoat
Assistant Superintendent,
Business & Fiscal Services
Dr. Jesus Vaca
Assistant Superintendent,
Human Resources & Support Services
Ms. Robin I. Freeman
Assistant Superintendent,
Educational Services

AGENDA #15
REGULAR BOARD MEETING
Wednesday, May 2, 2018
5:00 p.m. – Study Sessions
Closed Session to Follow
7:00 PM - Regular Board Meeting

***NOTE:** In accordance with requirements of the Americans with Disabilities Act and related federal regulations, individuals who require special accommodation, including but not limited to an American Sign Language interpreter, accessible seating or documentation in accessible formats, should contact the Superintendent's office at least two days before the meeting date.

Persons wishing to address the Board of Trustees on any agenda item may do so by completing a "**Speaker Request Form**" and submitting the form to the **Asst. Supt. of Human Resources**. The Speaker should indicate on the card whether they wish to speak during Public Comment or when a specific agenda item is considered.

Note: No new items will be considered after 10:00 p.m. in accordance with Board Bylaws, BB 9323 – Meeting Conduct

www.oxnardsd.org

OPIE TV – Charter Spectrum Channel 20 &
Frontier Communications - Channel 37

Section A PRELIMINARY

A.1 Call to Order and Roll Call 5:00 PM

The President of the Board will call the meeting to order. A roll call of the Board will be conducted.

ROLL CALL VOTE:

Madrigal Lopez __, **Robles-Solis** __, **O’Leary** __, **Morrison** __, **Cordes** __

A.2 Pledge of Allegiance to the Flag

Mary Arias Elisondo, Principal at Christa McAuliffe School of STEAM, will introduce Nathan James Matson, 5th grader in Ms. Keli Marcicek’s class, who will lead the audience in the Pledge of Allegiance.

A.3 District’s Vision and Mission Statements

The District’s Vision and Mission Statements will be read in English and Spanish by Alyssa Ruiz, 4th grader in Ms. Nancy Diaz’ class.

A.4 Presentation by Christa McAuliffe School of STEAM

Mary Arias Elisondo will provide a short presentation to the Board regarding Christa McAuliffe School of STEAM. Following the presentation President Cordes will present a token of appreciation to the students that participated in the Board Meeting.

A.5 Adoption of Agenda (Superintendent)

Moved:
Seconded:
Vote:

ROLL CALL VOTE:

Madrigal Lopez __, **Robles-Solis** __, **O’Leary** __, **Morrison** __, **Cordes** __

A.6 Study Session: State Aid Presentation by CFW (Morales/Penanhoat/CFW)

It is the recommendation of the Superintendent and the Assistant Superintendent, Business & Fiscal Services, in conjunction with Caldwell Flores Winters, that the Board of Trustees receive a presentation regarding a status update on the State Aid program and the District’s eligible projects.

A.7 Closed Session – Public Participation/Comment (Limit three minutes per person per topic)

Persons wishing to address the Board of Trustees on any agenda item identified in the Closed Session agenda may do so by completing a “Speaker Request Form” and submitting the form to the Assistant Superintendent of Human Resources and Support Services. Public Comment shall be limited to fifteen (15) minutes per subject with a maximum of three (3) minutes per speaker.

The Board will now convene in closed session to consider the items listed under Closed Session.

Note: No new items will be considered after 10:00 p.m. in accordance with Board Bylaws, BB 9323 – Meeting Conduct

**Section A
PRELIMINARY**
(continued)

A.8 Closed Session

1. Pursuant to Section 54956.9 of *Government Code*:
 - Conference with Legal Counsel – Anticipated Litigation: 1 case
 - Conference with Legal Counsel – Existing Litigations: 1 case
 - J.R. et. v. Oxnard School District et al. Central District No. CV-04304-JAK-FFM

2. REMOVAL/SUSPENSION/EXPULSION OF A STUDENT (*Education Code 48912; 20 U.S.C. Section 1232g*)
 - Case No. 17-14 (Action Item)

3. Pursuant to Sections 54957.6 and 3549.1 of the *Government Code*:
 - Conference with Labor Negotiator:
 - Agency Negotiators: OSD Assistant Superintendent, Human Resources & Support Services, and Garcia Hernández & Sawhney, LLP
 - Association(s): OEA, OSSA, CSEA;
 - and All Unrepresented Personnel – Administrators, Classified Management, Confidential

4. Pursuant to Section 54956.8 of the *Government Code*:
 - Conference with Real Property Negotiators (for acquisition of new school site):
 - Property: Parcel located Teal Club Road, North of Teal Club Road, South of Doris Avenue
 - Agency Negotiators: Superintendent/Assistant Superintendent, Business & Fiscal Services/ Garcia Hernandez & Sawhney, LLP/ Caldwell Flores Winters Inc.
 - Negotiating Parties: Dennis Hardgrave on behalf of the property owners
 - Under Negotiations: Instruction to agency negotiator on price and terms.

5. Pursuant to Section 54957 of the *Government Code* and Section 44943 of the *Education Code* the Board will consider personnel matters, including:
 - Public Employee(s) Discipline/Dismissal/Release

A.9 Reconvene to Open Session

7:00 PM

A.10 Report Out of Closed Session

The Board will report on any action taken in closed session or take action on any item considered in closed session, including expulsion of students:

REMOVAL/SUSPENSION/EXPULSION OF STUDENTS

(*Education Code 48912; 20 U.S.C. Section 1232g*)

Case No. 17-14 (Action Item)

Motion: _____, Second: _____

ROLL CALL VOTE:

Madrigal Lopez __, Robles-Solis __, O’Leary __, Morrison __, Cordes __

Note: No new items will be considered after 10:00 p.m. in accordance with Board Bylaws, BB 9323 – Meeting Conduct

Section A
PRELIMINARY
(continued)

A.11 Recognition of Oxnard School District’s Million Word Readers – Driffill, Chavez, and Curren Schools (Freeman/Curtis)

The Board of Trustees will recognize Oxnard School District students who have read One Million Words.

A.12 Adoption and Presentation of Resolution #17-39 in Recognition of “Teacher Appreciation Week 2018” (Dr. Morales)

The Board of Trustees will adopt and present Resolution #17-39 “Teacher Appreciation Week 2018”, recognizing May 7-11, 2018 as Teacher Appreciation Week 2018, to representatives of the Oxnard Educators Association.

A.13 Adoption and Presentation of Resolution #17-35 “National School Nurse Day - May 9, 2018” (Freeman/Ridge)

The Board of Trustees will adopt Resolution #17-35 “National School Nurse Day”, recognizing May 9, 2018 as National School Nurse Day. The Board will recognize and present the Resolution to School Nurses in attendance.

Note: No new items will be considered after 10:00 p.m. in accordance with Board Bylaws, BB 9323 – Meeting Conduct

Section B
PUBLIC COMMENT/HEARINGS

B.1 Public Comment (3 minutes per speaker)

Members of the public may address the Board on any matter within the Board's jurisdiction at this time or at the time that a specific agenda item is being considered. Comments should be limited to three (3) minutes. Please know this meeting is being video-recorded and televised. The Board particularly invites comments from parents of students in the District.

B.1 Comentarios del Público (3 minutos para cada ponente)

Los miembros del público podrán dirigirse a la Mesa Directiva sobre cualquier asunto que corresponda a la jurisdicción de la Mesa Directiva en este periodo o cuando este punto figure en el orden del día y sea analizado. Los comentarios deben limitarse a tres (3) minutos. Tenga presente que esta reunión está siendo grabada y televisada. La Mesa Directiva invita en particular a los padres y alumnos del distrito a que presenten sus comentarios.

**Note: No new items will be considered after 10:00 p.m. in accordance with
Board Bylaws, BB 9323 – Meeting Conduct**

Section C CONSENT AGENDA

(All Matters Specified as Consent Agenda are considered by the Board to be routine and will be acted upon in one motion. There will be no discussion of these items prior to the time the Board votes on the motion unless members of the Board request specific items be discussed and/or removed from the Consent Agenda.)

Notes:
Moved:
Seconded:

ROLL CALL VOTE:

Madrigal Lopez ____, **Robles-Solis** ____, **O’Leary** ____, **Morrison** ____, **Cordes** ____

C.1 Agreements

It is recommended that the Board approve the following agreements: Dept/School

Enrichment:

- #17-301 with All for KIDZ, Inc., to provide a school-wide character education program that centers around a 45-minute assembly called The NED Show for students at Elm School on Monday, April 30, 2018, no fiscal impact. Freeman/
Ramos

Support Services:

- #18-03 with enVision Consulting Group, to provide families with important information and notifications related to District procedures and policies which are updated annually, the Annual Parent Rights Notification Handbook, and also provides translation services for the handbook; amount not to exceed \$3,000.00, to be paid out of the General Fund. Freeman/
Ridge

C.2 Ratification of Agreements

It is recommended that the Board ratify the following agreements: Dept/School

Academic:

- #17-304 with Our Lady of Guadalupe School, Oxnard School District will provide services to Our Lady of Guadalupe School, a private school located within the geographic jurisdiction of this school district, through the Limited English Proficient Student Program funded under the Elementary and Secondary Education Act, Title III, Part A for the 2017-2018 school year; Title III Allocation to Our Lady of Guadalupe School, in the amount of \$1,912.00. Freeman/
Thomas

Enrichment:

- #17-303 with Focus on the Masters, provided two Learning to See residencies, each with one lesson for eight weeks per semester, for Ms. Castro’s 7th grade Creative Writing class; amount not to exceed \$1,000.00, to be paid with School Site Funds, Non-Targeted. Freeman/
Witherspoon

Special Education:

- #17-295 with Casa Pacifica School, for Non-Public School services for Student IH081410, for the 2017-2018 school year, including Extended School Year. The Non-Public School will provide a program of instruction, which is consistent with the pupil’s individual educational plan as specified in the individual service agreement, amount not to exceed \$15,138.00, to be paid with Special Education Funds. Freeman/
Sugden
- #17-296 with Assistance League, Non-Public School services for Students AV100514, GB013114, and JS100214, for the 2017-2018 school year, beginning February 2018 and including Extended School Year. The Non-Public School will provide a program of instruction, which is consistent with the pupils’ individual educational plan as specified in the individual service agreement, amount not to exceed \$11,900.00, to be paid with Special Education Funds. Freeman/
Sugden

Note: No new items will be considered after 10:00 p.m. in accordance with Board Bylaws, BB 9323 – Meeting Conduct

**Section C
CONSENT AGENDA**

(continued)

C.2 Ratification of Agreements (continued) Dept/School

Special Education:

- #17-302 with Ventura County Office of Education for the 2017-2018 school year, to provide exceptional services to special education students (OL083008, AC070205, RR103108, and IR033009) that consist of support from Special Circumstances Paraeducators, including Extended School Year, amount not to exceed \$65,297.40; to be paid from Special Education Funds. Freeman/
Sugden

C.3 Approval to Set Date for Notice of Public Hearing re: Sunshine of the Oxnard Supportive Services Association (OSSA) and the Oxnard School District's (District) Initial Proposals for 2018-2019 Negotiations, Pursuant to Government Code Section 3547

In accordance with Article 22, Term, of the current collective bargaining agreement between the Oxnard Support Services Association (OSSA) and the Oxnard School District (District), the District and OSSA would like to enter into contract negotiations for the 2018-2019 school year and any additional years as may be mutually agreed upon by the parties. Pursuant to the provisions of Government Code Section 3547, OSSA and the District are submitting their intent to meet the public notice provision of the Educational Employment Rights Act. It is the recommendation of the Assistant Superintendent of Human Resources that the Board schedule May 16, 2018 for the Public Hearing for OSSA and the District's proposals. Dept/School
Vaca

C.4 Approval of Resolution #17-40: Designation of Applicant's Agent Resolution for Non-State Agencies

In conjunction with the Ventura County Schools Self-Funding Authority (VCSSFA), the Administration has submitted a Request for Public Assistance (RPA) to the Governor's Office of Emergency Services (OES) to obtain federal and state financial assistance made available as a result of the 2017 California Wildfires. The OES requires that the Board of Trustees designate via resolution those agents authorized to act on behalf of the District for all matters pertaining to federal and state financial assistance. Said agents will execute all necessary documents for and on behalf of the Oxnard School District. It is the recommendation of the Assistant Superintendent, Business & Fiscal Services, and the Risk Manager, that the Board of Trustees approve Resolution #17-40 as presented. Dept/School
Penanhoat/
Magana

C.5 Personnel Actions

It is the recommendation of the Assistant Superintendent, Human Resources & Support Services and the Interim Director, Classified Human Resources, that the Board of Trustees approve the personnel actions, as presented. Dept/School
Vaca/
Bailey

Note: No new items will be considered after 10:00 p.m. in accordance with Board Bylaws, BB 9323 – Meeting Conduct

Section D
ACTION ITEMS

(Votes of Individual Board Members must be publicly reported.)

D.1 Approval of a Contractor Contingency Allocation No. 001 to the Marshall New Classroom Building Project's Contractor Contingency for an Increase of Cost for the Work Associated with the Project

| | |
|--|--|
| It is the recommendation of the Assistant Superintendent, Business & Fiscal Services, and the Director of Facilities, in conjunction with Caldwell Flores Winters, Inc., that the Board of Trustees approve Contingency Allocation No. 001 to Construction Services Agreement #17-117 with Bernards, for additional items of work related to the Marshall New Classroom Building Project, in the amount of \$ 32,714.00. | Dept/School Penanhoat/ Fateh/ CFW |
|--|--|

Motion: _____, Second: _____

ROLL CALL VOTE:

Madrigal Lopez __, **Robles-Solis** __, **O'Leary** __, **Morrison** __, **Cordes** __

Note: No new items will be considered after 10:00 p.m. in accordance with Board Bylaws, BB 9323 – Meeting Conduct

Section E
APPROVAL OF MINUTES

No minutes will be approved at this meeting.

**Note: No new items will be considered after 10:00 p.m. in accordance with
Board Bylaws, BB 9323 – Meeting Conduct**

Section F
BOARD POLICIES

(These are presented for discussion or study.
Action may be taken at the discretion of the Board.)

F.1 First Reading of Board Policies, Regulations and Bylaws

It is recommended that the Board review the following revised Board Policies, Administrative Regulations and Bylaws, as presented, and approve for a first reading:

| | | |
|------------------------------|--|------|
| Revision BP & AR 5145.7 | Students SEXUAL HARASSMENT | Vaca |
| Revision BP 0410 | Philosophy, Goals, Objectives, and Comprehensive Plans NONDISCRIMINATION IN DISTRICT PROGRAMS AND ACTIVITIES | Vaca |
| Revision BP and AR 1312.3 | Community Relations UNIFORM COMPLAINT PROCEDURES | Vaca |

Due to additional revisions, the following revised Board Policies, Administrative Regulations and Bylaws, are being resubmitted for review, as a first reading:

| | | |
|-----------------------|-----------------------------------|---------|
| Revision BP 6162.5 | Instruction STUDENT ASSESSMENT | Freeman |
|-----------------------|-----------------------------------|---------|

**Note: No new items will be considered after 10:00 p.m. in accordance with
Board Bylaws, BB 9323 – Meeting Conduct**

**Section G
CONCLUSION**

G.1 Superintendent’s Announcements (3 minutes)

A brief report will be presented concerning noteworthy activities of district staff, matters of general interest to the Board, and pertinent and timely state and federal legislation.

Notes:

G.2 Trustees’ Announcements (3 minutes each speaker)

The trustees’ report is provided for the purpose of making announcements, providing conference and visitation summaries, coordinating meeting dates, identifying board representation on committees, and providing other information of general interest.

Notes:

G.3 ADJOURNMENT

Moved:
Seconded:
Vote:

ROLL CALL VOTE:

Madrigal Lopez __, Robles-Solis __, O’Leary __, Morrison __, Cordes __

Note: No new items will be considered after 10:00 p.m. in accordance with Board Bylaws, BB 9323 – Meeting Conduct



Vision:

Empowering All Children to Achieve Excellence

Mission:

Ensure a culturally diverse education for each student in a safe, healthy and supportive environment that prepares students for college and career opportunities.



Visión:

Capacitar a cada alumno para que logre la excelencia académica

Misión:

Asegurar una educación culturalmente diversa para todo el alumnado en un ambiente seguro, saludable y propicio que les prepare para la Universidad y el acceso a oportunidades para desarrollar una carrera profesional.

OSD BOARD AGENDA ITEM

Name of Contributor: Robin I Freeman

Date of Meeting: 5/2/18

- A. Preliminary X
Study Session: _____
- B. Hearing: _____
- C. Consent Agenda _____ Agreement Category:
_____ Academic
_____ Enrichment
_____ Special Education
_____ Support Services
_____ Personnel
_____ Legal
_____ Facilities
- D. Action Items _____
- E. Report/Discussion Items (no action) _____
- F. Board Policies 1st Reading _____ 2nd Reading _____

**Recognition of Students - Honoring Oxnard School District's Million Word Readers
(Freeman/Curtis)**

Students who have read One Million Words will be recognized by the Board of Trustees. Students will receive a t-shirt that states, "I Read 1,000,000 Words What's your Superpower."

FISCAL IMPACT: None

RECOMMENDATION: It is the recommendation of the Assistant Superintendent, Educational Services and the Director of Curriculum, Instruction and Accountability that the Board of Trustees accept this item as presented.

ADDITIONAL MATERIAL: None



OXNARD SCHOOL DISTRICT

Resolution # 17-39

Teacher Appreciation Week 2018 ***May 7-11, 2018***

WHEREAS, the Board of Trustees have the utmost respect and admiration for our teachers who are dedicating their lives and talents to the education of our children, who are Oxnard's most precious and valuable resource; and

WHEREAS, teachers open children's minds to the magic of ideas, knowledge, and new possibilities. They keep American democracy alive by laying the foundation for good citizenship; and

WHEREAS, teachers, in partnership with parents, instill sound values and good character in our nation's young people; and

WHEREAS, teachers fill many roles, as listeners, explorers, role models, motivators and mentors; and

WHEREAS, teachers strive for excellence in each classroom and school; and reach out to every child, regardless of ability, class, color, or creed; and

WHEREAS, the guidance, support and inspiration that teachers provide to students are invaluable and contribute tremendously to the well-being of our nation.

THEREFORE, BE IT RESOLVED, that the Oxnard School District hereby recognizes and honors the contributions of teachers in the Oxnard School District to quality education and declares the week of May 7-11, 2018 be observed as "*Teacher Appreciation Week 2018*" in the Oxnard School District.

BE IT FURTHER RESOLVED that the Board extends, throughout the year, its sincere appreciation to the teachers and support staff members of the Oxnard School District for their extraordinary dedication and professional commitment to the students of Oxnard.

Adopted this 2nd day of May, 2018.

President, Board of Trustees

Clerk, Board of Trustees

Member, Board of Trustees

Member, Board of Trustees

Member, Board of Trustees

BOARD AGENDA ITEM

Name of Contributor: Robin I Freeman

Date of Meeting: 5/2/18

STUDY SESSION _____

CLOSED SESSION _____

SECTION A-1: PRELIMINARY X

SECTION A-II: REPORTS _____

SECTION B: HEARINGS _____

SECTION C: CONSENT AGENDA Agreement Category:

- _____ Academic
- _____ Enrichment
- _____ Special Education
- _____ Support Services
- _____ Personnel
- _____ Legal
- _____ Facilities

SECTION D: ACTION _____

SECTION E: APPROVAL OF MINUTES _____

SECTION F: BOARD POLICIES 1ST Reading _____ 2nd Reading _____

Resolution #17-35 “National School Nurse Day.” May 9, 2018 (Freeman/Ridge)

Recognition of May 9, 2018 as “National School Nurses Day” as proclaimed by the National Association of School Nurses.

School Nurses are a critical member of our support staff; they are responsible for providing vital links, public and private resources and programs. Our nurses collaborate with Special Education staff, teachers, administrators and parents to ensure that all health needs are addressed in the best interest of every child of the Oxnard School District. They are commended for their hard work in promoting wellness through health education; providing health screenings and services. It is important that all children are healthy and come to school ready to learn.

FISCAL IMPACT:

None

RECOMMENDATION

It is the recommendation of the Director of Pupil Services, and the Assistant Superintendent, Educational Services, that the Board of Trustees approve the Resolution #17-35 as outlined above.

ADDITIONAL MATERIAL(S):

Attached: Resolution (1 page)



**RESOLUTION NO. 17-35
OXNARD SCHOOL DISTRICT
BOARD OF TRUSTEES**

National School Nurse Day 2018
“School Nurses: Advocates for 21st Century Student Health”

WHEREAS, the National Association of School Nurses has proclaimed May 9, 2018, as National School Nurse Day; and

WHEREAS, all students have a right to have their physical and mental health needs safely met while in the school setting; and

WHEREAS, students today face more complex and life-threatening health problems requiring care in school; and

WHEREAS, school nurses have served a critical role in improving public health and in ensuring student’s academic success for more than 100 years; and

WHEREAS, school nurses address the home and community factors (e.g. social determinants) that impact student’s health; and

WHEREAS, school nurses are professional nurses that advance the well-being, academic success, and life-long achievements of all students by serving on the frontlines and providing a critical safety net for our nation’s most fragile children; and

WHEREAS, school nurses act as a liaison to the school community, parents, and health care providers on behalf of children’s health by promoting wellness and improving health outcomes for our nation’s children; and

WHEREAS, school nurses support the health and educational success of children and youth by providing access to care when children’s cognitive development is at its peak; and

WHEREAS, school nurses are members of school-based teams (e.g. school health services, 504/IEP, disaster/emergency planning) to address the school population; and

WHEREAS, school nurses understand the link between health and learning and are in a position to make a positive difference for children every day, therefore

BE IT FURTHER RESOLVED that the Board of Trustees encourages the Oxnard community to celebrate and acknowledge the accomplishments of the School Nurses and their efforts of meeting the needs of our students by improving the delivery of health care in our schools, our School Nurses also contribute to our local communities by helping students stay healthy, in school, and ready to learn, and keeping parents and guardians at work throughout the school year.

Adopted this 2nd day of May 2018.

President, Board of Trustees

Clerk, Board of Trustees

Member, Board of Trustees

Member, Board of Trustees

Member, Board of Trustees

OSD BOARD AGENDA ITEM

Name of Contributor: Robin Freeman

Date of Meeting: 5/2/18

- Study Session:** _____
Closed Session _____
- A-1. Preliminary** _____
A-II. Reports _____
B. Hearings _____
C. Consent Agenda _____
- Agreement Category:**
____ Academic
 X Enrichment
____ Special Education
____ Support Services
____ Personnel
____ Legal
____ Facilities
- D. Action Items** _____
F. Board Policies 1st Reading _____ 2nd Reading _____

Approval of Agreement #17-301 – All for KIDZ, Inc. (Freeman/Ramos)

All for KIDZ, Inc. will provide a school-wide character education program that centers around a 45-minute assembly called The NED Show for students at Elm School on Monday, April 30, 2018. NED is a lovable cartoon character whose name is an acronym for Never give up, Encourage others, and Do your best.

FISCAL IMPACT:

None

RECOMMENDATION:

It is the recommendation of the Principal, Elm School, and the Assistant Superintendent, Educational Services, that the Board of Trustees approve Agreement #17-301 with All for KIDZ, Inc.

ADDITIONAL MATERIAL(S):

Attached: Agreement #17-301, All for KIDZ, Inc. (1 Page)
 Certificate of Insurance (4 Pages)



PERFORMANCE AGREEMENT

Show Date: April 30, 2018 SchID: 11952
 Show Time: 8:15 am - 9:00 am, 9:15 am - 10:00 am
 School: Elm Street Elementary School
 Contact Name/Title: Veronica Garcia, Counselor
 Booking Agent: Joanna Bachmann K-5, 625
 Toll Free: 877-872-9696, x110
 E-mail: jbachmann@allforkidz.com Fax: 800-969-6624

All for KIDZ, producers of The NED Show®, agrees to:

1. **Present The NED Show on the date and time entered above.**
2. **Grant access to resources and lesson plans** available at www.theNEDshow.com.
3. Provide **posters** for your school and **ready-to-copy materials** to send home with students.
4. **Reserve the right to reschedule** the performance due to performer illness or other extenuating circumstances. In the unlikely event of a change, the program will be moved to a mutually agreeable time.
5. **Waive the normal program fee of \$1,200** in lieu of your school running the five-day “Pay-It-Forward” sale featuring NED gear, since you have chosen the “No-Fee” payment option. **Bonus!** *If you exceed \$1,200 in sales, 10% of the entire proceeds will be awarded to your school in the form of a gift certificate toward character-messaged NED items (redeemable at www.shopned.com).*
6. **Provide prepaid UPS shipping labels**, so your school doesn't have to pay return postage on unsold items.

Your school agrees to:

1. **Copy the parent letter** (included in pre-show packet) **and send home with students** a few days before the show.
2. **Make NED items available for purchase** for a minimum of five (5) school days following the show and do your best to “pay-it-forward” to another school.
3. Do your best to **provide a NED play zone** for students to enjoy their NED items and safely practice yo-yo skills while reinforcing the NED message.
4. **Protect our copyright.** Take pictures of the show if you wish, but agree and enforce that no part of the program may be video recorded, reproduced or transmitted. All for KIDZ also reserves the right to occasionally audio or video record its employees for training purposes.
5. **Contact us immediately** if you find it necessary to make any changes to your performance time. If your school cancels within 14 days of the scheduled performance date, you agree to pay a \$200 cancellation fee (does not include unforeseen acts of nature, i.e. inclement weather or school closures).



CONFIRM *your* SHOW DATE

**Please sign below and email to customercare@allforkidz.com
or fax to 800-969-6624 within 48 hours.**

If you've already signed and faxed a performance agreement, please disregard. Retain this original for your records.

_____ Lisa A. Franz, Director, Purchasing

School Representative Signature Printed Name and Title

We look forward to taking **THE NED SHOW** to your school!



THIS ENDORSEMENT CHANGES THE POLICY. PLEASE READ IT CAREFULLY.

POLICY CHANGE

This endorsement changes the policy effective on the Inception Date of the policy unless another date is indicated below:

Policy Number: 52 SBA FV2437 SC

Named Insured and Mailing Address; ALL FOR KIDZ INC

20700 44TH AVE W STE 220
LYNNWOOD WA 98036

Policy Change Effective Date: 03/05/18

**Effective hour is the same as stated in the
Declarations Page of the Policy.**

Policy Change Number: 010

Agent Name: AJ GALLAGHER RISK MGMT SVCS INC
Code: 817439

POLICY CHANGES:

HARTFORD CASUALTY INSURANCE COMPANY

ANY CHANGES IN YOUR PREMIUM WILL BE REFLECTED IN YOUR NEXT BILLING STATEMENT. IF YOU ARE ENROLLED IN REPETITIVE EFT DRAWS FROM YOUR BANK ACCOUNT, CHANGES IN PREMIUM WILL CHANGE FUTURE DRAW AMOUNTS.

THIS IS NOT A BILL.

NO PREMIUM DUE AS OF POLICY CHANGE EFFECTIVE DATE

FORM NUMBERS OF ENDORSEMENTS REVISED AT ENDORSEMENT ISSUE:

IH12001185 ADDITIONAL INSURED - PERSON-ORGANIZATION

PRO RATA FACTOR: 0.164

THIS ENDORSEMENT DOES NOT CHANGE THE POLICY EXCEPT AS SHOWN.

Form SS 12 11 04 05 T

Process Date: 03/08/18

Page 001

Policy Effective Date: 05/04/17

Policy Expiration Date: 05/04/18

POLICY NUMBER: 52 SBA FV2437



THIS ENDORSEMENT CHANGES THE POLICY. PLEASE READ IT CAREFULLY.

ADDITIONAL INSURED - PERSON-ORGANIZATION

BEAUMONT UNIFIED SCHOOL DISTRICT
350 BROOKSIDE AVE,
BEAUMONT, CA 92223

RE:LOC 003 BLDG 001
BREVARD PUBLIC SCHOOLS
2700 JUDGE FRAN JAMIESON WAY
VIERA, FL 32940

RE: ALL FOR KIDZ IS PUTTING ON A LEARNING LIVE SHOW/ASSEMBLY THAT
WILL TEACH CHILDREN AT BREVARD PUBLIC SCHOOLS MUSICAL INSTRUMENTS

LOC:001 BLDG:001
DESOTO COUNTY SCHOOLS
5 EAST SOUTH ST
HERNANDO, MS 38632

MT DIABLO UNIFIED SCHOOL DISTRICT
1936 CARLOTTA DRIVE
CONCORD CA 94519

SANTA CLARA UNIFIED SCHOOL DISTRICT
1889 LAWRENCE ROAD
SANTA CLARA, CA 95051

OXNARD SCHOOL DISTRICT
1051 SOUTH A STREET
OXNARD, CA 93030

PRODUCER'S FACT SHEET

NAMED INSURED: ALL FOR KIDZ INC

POL #: 52 SBA FV2437 SC

PRODUCER'S NAME: AJ GALLAGHER RISK MGMT SVCS INC
PRODUCER'S CODE: 817439

POL EFF DATE: 05/04/17 POL EXP DATE: 05/04/18 TRANS EFF DATE: 03/05/18

DIRECT ACCOUNT BILL NUMBER - 12228514

TRANSACTION TYPE: ENDORSEMENT CHANGE NO.: 010

ENDORSEMENT PREMIUM: \$0.00

NON-PREMIUM BEARING

FORM

TITLE

SS 12 11 04 05

POLICY CHANGE

IH 12 00 11 85

ADDITIONAL INSURED - PERSON-ORGANIZATION

OSD BOARD AGENDA ITEM

Name of Contributor: Robin Freeman

Date of Meeting: 5/2/18

- Study Session:** _____
Closed Session _____
- A-1. **Preliminary** _____
A-II. **Reports** _____
B. **Hearings** _____
C. **Consent Agenda** _____
- Agreement Category:**
____ Academic
____ Enrichment
____ Special Education
 X **Support Services**
____ Personnel
____ Legal
____ Facilities
- D. **Action Items** _____
F. **Board Policies** 1st Reading _____ 2nd Reading _____

Approval of Agreement #18-03 – enVision Consulting Group (Freeman/Ridge)

California Education Code (EC) 48980 (“Ed Code”) requires school districts to notify parents annually of their rights and responsibilities with respect to a number of topics listed in the Ed Code. In Oxnard School District this is accomplished via distribution of the Annual Parent Rights Notification Handbook (“Handbook”) at the beginning of each school year.

The Handbook provides families with important information and notifications related to District procedures and policies. It is updated annually to comply with recent changes to the Ed Code as well as recent legislation. Each family is required to sign and return the “Acknowledgement of Receipt and Review” form included in the Handbook.

enVision Consulting Group assists the District in the yearly revision of the Annual Parent Rights Notification Handbook, and also provides translation services for the handbook.

Term of Agreement: **July 1, 2018 through June 30, 2019**

FISCAL IMPACT:

Not to exceed \$3,000.00 – General Fund

RECOMMENDATION:

It is the recommendation of the Director, Pupil Services, and the Assistant Superintendent, Educational Services, that the Board of Trustees approve Agreement #18-03 with enVision Consulting Group.

ADDITIONAL MATERIAL(S):

Attached: Agreement #18-03, enVision Consulting Group (6 Pages)



enVision Consulting Group

Consulting Services Agreement

This agreement is hereby entered into on May 2, 2018 (Effective Date) and between the **Oxnard School District**, hereinafter referred to as "District", and **enVision Consulting Group, Inc.**, (A California Corporation), hereinafter referred to as "Consultant."

WHEREAS, District is authorized by Section 53060 of the California Government Code to contract with and employ any persons for the furnishing of special services and advice in financial, economic, accounting, engineering, legal or administrative matters, if such persons are specially trained and experienced and competent to perform the special services required;

WHEREAS, District is in need of such special services and advice; and

WHEREAS, Consultant is specially trained and experienced and competent to perform the special services required by the District, and such services are needed on a limited basis;

NOW, THEREFORE, the parties agree as follows:

District accepts the following consulting services (indicate selections by initialing in provided space):

X Annual Parents' Rights Notification Services (Appendix A)

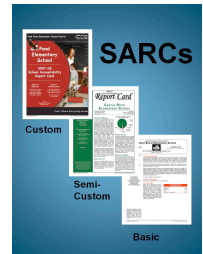

SARC



Translation Services

Consulting Services

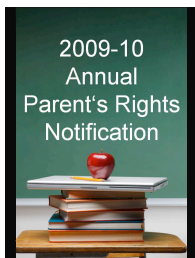

Annual Parent Notification

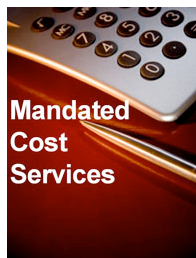

Mandated Costs

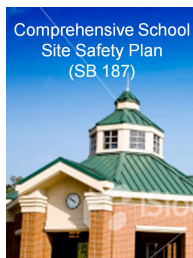

School Site Safety Plan

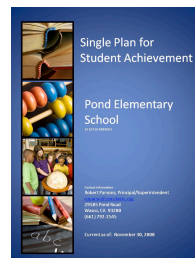

School Site Plan



Title I Notices



enVision Consulting Group

I. DISTRICT'S RESPONSIBILITIES

I.1. District will provide Consultant with all the documents, records and information necessary, in both electronic and paper copies to complete services. District agrees to promptly pay Consultant for fees for services rendered. Payments are due and payable within 30 days after the invoice date.

II. CONSULTANT'S RESPONSIBILITIES

II.1. See Appendix related to individual service agreement for specific responsibilities.

III. TERM

Consultant shall commence providing services under this agreement on Effective Date, and will diligently perform as required and complete services within timeframe indicated on Appendix A.

IV. EXPENSES

District shall not be liable to Consultant for any costs or expenses paid or incurred by Consultant in performing services for District.

V. INDEPENDENT CONTRACTOR

Consultant, in the performance of this agreement, shall be and act as an independent contractor. Consultant understands and agrees that Consultant and all of Consultant's employees shall not be considered officers, employees or agents of the District, and are not entitled to benefits of any kind or nature normally provided employees of the District and/or to which District's employees are normally entitled, including, but not limited to, State Unemployment Compensation or Workers' Compensation. Consultant assumes the full responsibility for the acts and/or omissions of its employees or agents as they relate to the services to be provided under this agreement. Consultant shall assume full responsibility for payment of all federal, state and local taxes or contributions, including unemployment insurance, social security and income taxes with respect to Consultant's employees.

VI. MATERIALS

VI.1. Consultant shall furnish, at its own expense, all labor, materials, equipment, supplies and other items necessary to complete the services to be provided pursuant to this agreement.

VI.2. Consultant's services will be performed, findings obtained, reports and recommendations prepared in accordance with generally and currently accepted principles and practices of Consultant's profession.



enVision Consulting Group

VII. TERMINATION

District may, with or without reason, terminate this agreement and compensate Consultant for services rendered to the date of termination. District must submit termination request in writing and deliver via certified U. S. Mail to Consultant 30 days prior to actual date of termination of services by Contractor. Notice shall be deemed given when received by the Consultant or no later than three days after the day of mailing, whichever is sooner.

VIII. HOLD HARMLESS

VIII.1. Consultant agrees to and does hereby indemnify, hold harmless and defend the District and its governing board, officers, employees and agents from every claim or demand made and every liability, loss, damage or expense, of any nature whatsoever, which may be incurred by reason of:

VIII.1.1. Liability for damages for: (1) death or bodily injury to person; (2) injury to, loss or theft of property; or (3) any other loss, damage or expense arising out of (1) or (2) above, sustained by the Consultant or any person, firm or corporation employed by the Consultant, either directly or by independent contract, upon or in connection with the services called for in this agreement, however caused, except for liability for damage referred to above which result from the negligence or willful misconduct of the District or its officers, employees or agents.

VIII.1.2. Any injury to or death of any person(s), including the District's officers, employees and agents, or damage to or loss of any property caused by any act, neglect, default, or omission of the Consultant, or any person, firm or corporation employed by the Consultant, either directly or by independent contract, arising out of, or in any way connected with, the services covered by this agreement, whether said injury or damage occurs whether on or off District's property, except for liability for damages which result from the sole negligence or willful misconduct of the District or its officers, employees or agents.

VIII.1.3. Any liability for damages which may arise from the furnishing or use of any copyrighted or uncopyrighted matter or patented or unpatented invention under this agreement.

IX. WORKERS' COMPENSATION

Consultant shall purchase and maintain policies of Workers' Compensation and Employers Liability Insurance in accordance with the laws of the State of California.

X. COMPLIANCE WITH APPLICABLE LAWS

The services completed herein must meet the approval of the District and shall be subject to the District's general right of inspection to secure the satisfactory completion thereof. Consultant agrees to comply with all federal, state and local laws, rules, regulations and ordinances that are now or may in the future become applicable to Consultant, Consultant's business, equipment and personnel engaged in services covered by this agreement or accruing out of the performance of such services.



enVision Consulting Group

XI. ENTIRE AGREEMENT/AMENDMENT

This agreement and any exhibits attached hereto constitute the entire agreement among the parties to it and supersedes any prior or contemporaneous understanding or agreement with respect to the services contemplated, and may be amended only by a written amendment executed by both parties to the Agreement.

XII. NOTICE

All notices or demands to be given under this agreement by either party to the other, shall be in writing and given either by (a) personal service or (b) by U. S. Mail, mailed either by registered or certified mail, return receipt requested, with postage prepaid. Service shall be considered given when received if personally served or if mailed on the third day after deposit in any U. S. Post Office. The address to which notices or demands may be given by either party may be changed by written notice given in accordance with the notice provisions of this section. At the date of this agreement, the addresses of the parties are as follows:

District:

Oxnard School District
1051 South A Street
Oxnard, CA 93030-7442

Consultant:

enVision Consulting Group, Inc.
10535 Foothill Boulevard, Suite 410
Rancho Cucamonga, CA 91730

XIII. SEVERABILITY

If any term, condition or provision of this agreement and any exhibit attached hereto is held by a court of competent jurisdiction to be invalid, void, or unenforceable, the remaining provisions will nevertheless continue in full force and effect, and shall not be affected, impaired or invalidated in any way.

XIV. ATTORNEY FEES/COSTS

Should litigation be necessary to enforce any terms or provisions of this agreement, then each party shall bear its own litigation and collection expenses, witness fees, court costs, and attorneys' fees.

THIS AGREEMENT IS ENTERED INTO THIS 2nd DAY OF May.

BOARD APPROVAL DATE: _____

Oxnard School District

enVision Consulting Group, Inc.

By: _____
(Signature of authorized representative)

By : _____

Lisa A. Franz, Director, Purchasing
(Print name of authorized representative)

Beth Hunter, President



enVision Consulting Group

Appendix A

ANNUAL PARENT’S RIGHTS NOTIFICATION

NOW, THEREFORE, the parties agree as follows:

1. Services to be provided by consultant: Preparation of Annual Parent’s Rights Notification as required by Education Code Section 48980.

I. CONSULTANT’S RESPONSIBILITIES

- I.1. Consultant shall collect, document and process the information necessary to prepare Annual Parent’s Rights Notification.
- I.2. Consultant will provide one completed English version of Annual Parent’s Rights Notification in grayscale, along with an electronic file for English versions (in a Portable Document Format) on CD Rom.
- I.3. Consultant will make a good faith effort to prepare Annual Parent’s Rights Notification in accordance with existing laws, regulations and applicable written guidelines.

II. SUPPLEMENTARY SERVICES

- II.1. Spanish Translation Services – should District elect Spanish Translation services (English to Spanish) in the Compensation section of this agreement, Consultant shall translate from English to Spanish the Annual Parent’s Rights Notification and will provide one completed Spanish version of Annual Parent’s Rights Notification in grayscale, along with an electronic file for Spanish Version (in a portable Document Format) on CD Rom.
- II.2. Printing Services – should District elect printing services, Consultant will provide district with a quote related to the specific document format selected by the district and the number of notices required to be printed by Consultant.

III. COMPENSATION

District agrees to pay the Consultant for services satisfactorily rendered pursuant to this agreement a fee of (select term/compensation by initialing in the space provided):



enVision Consulting Group

Annual Parent's Rights Notification

- One Year Agreement – 2018-19 APN
\$1,500 for Annual Parent's Rights Notification services performed during the term of this contract for all required components. District may elect to include up to 5 additional pages of information at the rate of **\$500 billed in addition to the fixed rate**. The contract includes all fees and expenses.
- Two-Year Agreement - 2018-19 & 2019-20 APN
\$1,250 for Annual Parent's Rights Notification services performed during the term of this contract for all required components. District may elect to include up to 5 additional pages of information at the rate of **\$500 billed in addition to the fixed rate**. The contract includes all fees and expenses.
- Three-Year Agreement – 2018-19, 2019-20 & 2020-21 APN
\$1,000 for Annual Parent's Rights Notification services performed during the term of this contract for all required components. District may elect to include up to 5 additional pages of information at the rate of **\$500 billed in addition to the fixed rate**. The contract includes all fees and expenses.

Fee schedule for Annual Parent's Rights Notification services is as follows:

| <u>Payment Amount</u> | <u>Due Date</u> |
|-----------------------|---|
| 70% | Upon execution of contract |
| 20% | Upon delivery of Annual Parent's Rights Notification draft |
| 10% | Upon delivery of completed, approved Annual Parent's Rights Notification document |

SPANISH TRANSLATION SERVICES

- District accepts Spanish Translation Services** and has selected the following term/compensation:
- One Year Agreement – 2018-19 APN
\$500 Annual Parent's Rights Notification English to Spanish translation services performed during the term of this agreement. District may elect to include up to 5 additional pages of information at the rate of **\$250 billed in addition to the fixed rate**.
- Two-Year Agreement - 2018-19 & 2019-20 APN
\$450 Annual Parent's Rights Notification English to Spanish translation services performed during the term of this agreement. District may elect to include up to 5 additional pages of information at the rate of **\$250 billed in addition to the fixed rate**.
- Three-Year Agreement – 2018-19, 2019-20 & 2020-21 APN
\$400 Annual Parent's Rights Notification English to Spanish translation services performed during the term of this agreement. District may elect to include up to 5 additional pages of information at the rate of **\$250 billed in addition to the fixed rate**.

Fee schedule for Spanish Translation services is as follows:

| <u>Payment Amount</u> | <u>Due Date</u> |
|-----------------------|----------------------------|
| 50% | Upon execution of contract |
| 50% | Upon delivery of drafts |

OSD BOARD AGENDA ITEM

Name of Contributor: Robin Freeman

Date of Meeting: 5/2/18

- Study Session:** _____
Closed Session _____
- A-1. Preliminary** _____
A-II. Reports _____
B. Hearings _____
C. Consent Agenda _____
- Agreement Category:**
 Academic
 Enrichment
 Special Education
 Support Services
 Personnel
 Legal
 Facilities
- D. Action Items** _____
F. Board Policies **1st Reading** _____ **2nd Reading** _____

**Ratification of Agreement/MOU #17-304 – Our Lady of Guadalupe School
(Freeman/Thomas)**

The Oxnard School District will provide services to Our Lady of Guadalupe School, a private school located within the geographic jurisdiction of this school district, through the Limited English Proficient (LEP) Student Program funded under the Elementary and Secondary Education Act, Title III, Part A for the 2017-2018 school year.

FISCAL IMPACT:

Title III Allocation to Our Lady of Guadalupe School - \$1,912.00

RECOMMENDATION:

It is the recommendation of the Director, Curriculum, Instruction & Accountability, and the Assistant Superintendent, Educational Services that the Board of Trustees ratify Agreement/MOU #17-304 with Our Lady of Guadalupe School.

ADDITIONAL MATERIAL:

Attached: Agreement/MOU #17-304, Our Lady of Guadalupe School (2 Pages)



Oxnard School District

1051 South "A" Street Oxnard, California 93030 805/385-1501

Memorandum of Understanding ESEA Title III

Provision of Limited English Proficient Student Programs and Services to Private Schools

2017-2018 School Year

Section 1: General

The **Oxnard School District** has been notified by **Our Lady of Guadalupe School**, a private school located within the geographic jurisdiction of this school district, of a request to participate in the Limited English Proficient (LEP) Student Program funded under the Elementary and Secondary Education Act, Title III, Part A for the 2016-2017 school year.

This Memorandum of Understanding (MOU) contains a description of the nature and scope of services and products to be provided by **Oxnard School District** to **Our Lady of Guadalupe School** in order to serve its English learner (EL) students.

Section 2: How will the students' needs be identified?

Based on the most recent EL student identification procedures, [66] ELs were identified on [8/15/17].

The EL student identification process consisted of the Home Language Survey followed by the administration of an English proficiency assessment and an academic assessment selected and approved by **Oxnard School District** after consultation with **Our Lady of Guadalupe School**. **Our Lady of Guadalupe School** shall determine when EL students become fluent English-proficient based on the results of the aforementioned instruments.

Section 3: What services and products will be provided?

Students will receive small group intervention out of the classroom through a student support staff assistant according to their level of required intervention.

The following materials and programs are requested:

Oxnard School District will provide the following: a series of research-based professional development workshops.

Section 4: How, when, where, and by whom will the services be provided? The students will be given 45 minutes twice a week in a small group setting to improve their acquisition of the English Language.

1. The primary language literature and supplements will be ordered from Institute for Excellence in Writing and "Teach your child to Read in 100 Easy Lessons." We will also order supplements from our current Reading publishers at **Our Lady of Guadalupe School**.

Section 5: How will the services be assessed and how will this information be used to improve the program?

Representatives of **Oxnard School District** and **Our Lady of Guadalupe School** shall meet in April/May of the year in which services have been offered to discuss the delivery and effectiveness of services provided to EL students. The representatives shall determine if any changes are needed in the program during the current or next school year.

Section 6: Other provisions including contract services through potential third-party providers and reversion of funds stipulations

Both parties of this MOU shall fulfill the conditions listed herein.

Section 7: Signatures of authorized representatives

For Our Lady of Guadalupe School:

Name: Mrs. Valerie Vespe Phone No: 805-483-5116

Signature:  Date: 4/16/18

Title: Principal

For Oxnard School District:

Name: Lisa A. Franz Phone No: 805-385-1501

Signature: _____ Date: _____

Title: Director, Purchasing

OSD BOARD AGENDA ITEM

Name of Contributor: Robin Freeman

Date of Meeting: 5/2/18

- Study Session: _____
Closed Session _____
A-1. Preliminary _____
A-II. Reports _____
B. Hearings _____
C. Consent Agenda _____
- Agreement Category:
 Academic
 Enrichment
 Special Education
 Support Services
 Personnel
 Legal
 Facilities
- D. Action Items _____
F. Board Policies 1st Reading _____ 2nd Reading _____

Ratification of Agreement #17-303 – Focus on the Masters (Freeman/Witherspoon)

Focus on the Masters provided two (2) Learning To See (LTS) residencies, each with one lesson for eight (8) weeks per semester, for Ms. Castro’s 7th grade Creative Writing class.

FISCAL IMPACT:

Not to exceed \$1,000.00 – School Site Funds, Non-Targeted

RECOMMENDATION:

It is the recommendation of the Principal, Fremont Academy, and the Assistant Superintendent, Educational Services, that the Board of Trustees ratify Agreement #17-303 with Focus on the Masters.

ADDITIONAL MATERIAL:

Attached: Agreement #17-303, Focus on the Masters (1 Page)



A Fine Arts Experience for Youth

·Provided by Focus on the Masters·

CONTRACT between FOTM and Fremont Academy

| | | | |
|--|-----------------------------|------------------------|---|
| Contract Number | LTS278 | For | 2 residencies, 8 lessons each |
| Date of Contract | September 11, 2017 | | |
| School/Institution | Fremont Middle | Billing Address | 1130 North M Street, Oxnard CA 93030 |
| Responsible Party | Fremont Middle School & PTA | Phone # | |
| Contact Person/Teacher | Michel Haun/Susan Castro | Phone # | |
| Number of Students | Max 40 students | Grade | 7 |
| Location of Instruction Session | Fremont Intermediate | Room # | |
| Day of Instruction | Mondays | Time | Period 3 |
| Instruction Starts | Sept 11, 2017 | Ends | Feb. 20, 2018 |
| LTS Instructor | Aimee French | Phone # | (805)653-2501 |
| LTS Fee | \$500 each | Total | \$1000 |

This is an agreement for services hereafter described and subject to the following items and conditions:

1. DESCRIPTION OF SERVICES: Two *Learning To See* (LTS) residencies, each with one lesson for eight (8) weeks per semester for Ms. Castro’s 7th Creative Writing class provided by Focus on the Masters’ *Learning To See* Outreach Program. : 9/11/17, 9/18/17, 9/25/17, 10/2/17, 10/9/17, 10/16/17, 10/23/17 and 11/6/17 and winter semester: 12/4/17, 12/2/17, 1/8/18, 1/16/18, 1/23/18, 2/7/18, 2/13/18 and 2/20/18

2. INSTITUTION RESPONSIBILITIES:

- ◆ Please submit payment for invoice provided upon receipt.
- ◆ An institution’s staff member will be present in the classroom at all times.
- ◆ A computer, projector and white screen will be set up for each lesson **prior to the arrival of the LTS instructor.**
- ◆ If the host teacher needs to reschedule a class after the schedule has been agreed upon between FOTM and your institution, the LTS instructor will make every effort to reschedule, but may be unable to reschedule a class due to calendar conflict.

3. LTS INSTRUCTOR RESPONSIBILITIES:

- ◆ Lessons will be up to 60 minutes in length.
- ◆ Supplies are provided, limited to a \$50 budget per residency.
- ◆ If the LTS instructor is unable to attend due to illness or emergency and cannot arrange for a substitute LTS teacher, the LTS instructor will notify the school or institution as soon as possible and will reschedule the class at a mutually agreed upon date and time.

Please sign and return this contract upon receipt to:

Aimee French, Education Director · FOTM ·
505 Poli St. Suite 310, Ventura, California 93001 · Ph: 805/653-2501

I have read and agree with the above information.

Lisa A. Franz, Director, Purchasing

Name of authorized INSTITUTION representative

Signature

Date

Aimee French, Education Director

4/12/2018

Name of authorized FOTM representative

Signature

Date

____ Accounting copy

____ School copy

____ File copy



OXNARD SCHOOL DISTRICT

1051 South "A" Street • Oxnard, California 93030 • (805) 385-1501

AGREEMENT FOR NONPUBLIC, NONSECTARIAN SCHOOLING

AGREEMENT #17-295

THIS AGREEMENT, made and entered into this 2nd day of May 2018, by and between the OXNARD SCHOOL DISTRICT, hereinafter referred to as the District, and CASA PACIFICA SCHOOL, hereinafter referred to as the nonpublic, nonsectarian school.

WITNESSETH:

WHEREAS, the District is authorized by the provisions of the California Education Code, Section 56155 et seq., to contract with a nonpublic, nonsectarian school to provide services for certain pupils who are unable to benefit from regular education; and

WHEREAS, the District has determined, through evaluation and individual educational plans, that the following pupils are in need of such services;

Student: IH081410

NOW, THEREFORE, in consideration of their mutual promises contained herein, the parties hereto enter into a fixed price contract as follows:

1. The nonpublic school will provide a program of instruction which is consistent with the pupil's individual educational plan as specified in the individual service agreement attached hereto and made a part hereof, and that the nonpublic, nonsectarian schools basic educational program and designated instruction and services shall be described in a written statement to be provided to the school district prior to the execution of this agreement.
2. Services shall be provided for the **2017-2018** school year at a daily rate of \$176.00 for 67 days; this includes 20 days of extended school year through July 12, 2018; Speech & Language at a rate of \$128.00 an hour for 6.25 hours; and \$38.00 daily rate for round trip transportation for 67 days; services not to exceed **\$15,138.00.**
3. The nonpublic school shall keep attendance of each pupil daily and shall report attendance monthly to the school district. Such attendance records shall be kept in a California State school register and copies of such register shall be filed with monthly invoices to the district within thirty (30) days after the close of the school month. Separate attendance registers shall be submitted for all designated instruction and services.



OXNARD SCHOOL DISTRICT

1051 South "A" Street • Oxnard, California 93030 • (805) 385-1501

AGREEMENT #17-295

Page 2

4. The nonpublic school will notify the school district of any change in a pupil's placement and/or address within three (3) days after the nonpublic school is informed of such changes.

5. The nonpublic school will report within three (3) days to the school district if a pupil is removed from the school by the placement agency, parent or legal guardian, or if a pupil absents himself/herself from school without permission for more than five (5) consecutive school days. For the purposes of the contract, a parent is the natural or adoptive parent, legal guardian or surrogate parent appointed by the district of residence when the courts have removed the parents educational rights.

6. The nonpublic school shall notify the school district when a pupil is absent for five (5) consecutive school days because of illness. Notification will be in writing.

7. *The nonpublic school will not be paid for excused absences due to changes in the ADA laws. These absences shall count as non-instructional days and not compensated at the daily rate.*

8. The nonpublic school shall prepare and submit to the school district year-end reports and other data required for the annual review on or before April 15 of the current school year. Forms for year-end and other required reports shall be provided by the school district via the computerized special education support program (SESP).

9. In consideration of the services to be rendered by the nonpublic, nonsectarian school, the district agrees to payment as follows:

All cost for this service, including intake, testing, tuition, and elective not to exceed **\$15,138.00.**
for **Student: IH081410**

10. While engaged in carrying out and complying with the terms of this agreement, the nonpublic, nonsectarian school is an independent contractor and not an officer, agent, or employee of the district. The independent contractor will obtain a criminal record summary from the Department of Justice or a Department of Justice approved agency on all employees or contracted service providers who potentially have contact with students. This clearance will be completed prior to the person(s) first day of employment. No individual who has been convicted of a violent or serious felony as listed in subdivision C, of Section 1192.7 of the California Penal Code will be employed in any capacity that potentially involves contact with students. Nor will any person be employed who has been convicted of, or entered a plea of nolo contendere to charges of any sex offense as defined in Education Code 44011.



OXNARD SCHOOL DISTRICT

1051 South "A" Street • Oxnard, California 93030 • (805) 385-1501

AGREEMENT #17-295

Page 3

11. The school district may withhold payment to the nonpublic, nonsectarian school when, in the opinion of the district: (1) nonpublic school's performance in whole or in part, either has not been sufficient or is insufficiently documented, or: (2) nonpublic school has neglected, failed, or refused to provide information or to cooperate with the inspection, review or audit of the program conducted by nonpublic school or records relating thereto. The school district shall not withhold payments as specified in this paragraph unless the school district has notified the nonpublic, nonsectarian school, in writing, that nonpublic, nonsectarian school has not performed as specified herein. The notice shall specify that nonpublic, nonsectarian school has fourteen (14) days to make the required corrections. If, after the expiration of the fourteen (14) days, nonpublic, nonsectarian school has not corrected the situation as specified in the district's notice, the affected payments will be withheld and this agreement may be canceled for cause.

12. During the entire term of this agreement and any extension or modification thereof, the nonpublic school shall keep in effect a policy or policies of liability insurance, including coverage of owned and non-owned automobiles operated by nonpublic school for the purposes of this agreement, of at least \$1,000,000 for each person and \$1,000,000 for each accident or occurrence from all damages arising out of death, bodily injury, sickness, or disease from any one accident or occurrence, and \$3,000,000 for all damages and liability arising out of injury to or destruction of property for each accident or occurrence. Not later than the effective date of this contract, the nonpublic school shall provide the District with satisfactory evidence of insurance, naming the District as additional insured, including a provision for a twenty (20) calendar day written notice to District before cancellation or material change, evidencing the above specified coverage. The Nonpublic school shall at its own cost and expense, procure and maintain insurance under the Worker's Compensation Law of California. Said certificates shall specify that insurance shall not be canceled or changed in required limits unless the school district has been provided forty-five (45) days advance written notification of cancellation or change. The nonpublic, nonsectarian school shall also maintain Workers' Compensation Insurance coverage as required by law.

13. This Agreement, or any of its rights, obligations, provisions, or conditions, may not be assigned by either party without the written consent of the party.

14. This Agreement may be amended by mutual agreement of the parties and may be terminated by either party upon twenty (20) days advance notification.



OXNARD SCHOOL DISTRICT

1051 South "A" Street • Oxnard, California 93030 • (805) 385-1501

AGREEMENT #17-295

Page 4

IN WITNESS WHEREOF, the parties hereto have set their hands on the day and year first above written.

Date

Lisa A. Franz, Director, Purchasing
Oxnard School District

Date

Michael Redard, Chief Financial Officer
Casa Pacifica School, Nonpublic, Nonsectarian School

OSD BOARD AGENDA ITEM

Name of Contributor: Robin Freeman

Date of Meeting: 5/2/18

- Study Session: _____
 - Closed Session _____
 - A-1. Preliminary _____
 - A-II. Reports _____
 - B. Hearings _____
 - C. Consent Agenda _____
- Agreement Category:**
- _____ Academic
 - _____ Enrichment
 - X Special Education
 - _____ Support Services
 - _____ Personnel
 - _____ Legal
 - _____ Facilities
- D. Action Items _____
 - F. Board Policies 1st Reading _____ 2nd Reading _____

Ratification of Agreement #17-296 - Assistance League, Non-Public School, NPS (Freeman/Sugden)

Requesting approval for Non Public School (NPS) services for the student listed below for the 2017-2018 school year, beginning February 2018 and including Extended School year. The Non Public School will provide a program of instruction, which is consistent with the pupils' individual educational plan as specified in the individual service agreement.

Grade: Pre-K (3)

- AV100514 (5 months)**
- GB013114 (5 months)**
- JS100214 (4 months)**

FISCAL IMPACT:

Tuition Pre-K: \$850.00 monthly rate x 2 students x 5 months = \$8,500.00
 \$850.00 monthly rate x 1 student x 4 months = \$3,400.00
 (including Extended School Year; ESY)

Grand Total: \$11,900.00 - Services to be paid with Special Education Funds.

RECOMMENDATION:

It is the recommendation of the Director, Special Education Services, and the Assistant Superintendent, Educational Services, that the Board of Trustees ratify Agreement #17-296 with Assistance League School, NPS.

ADDITIONAL MATERIAL(S):

Attached: Agreement #17-296, Assistance League School, NPS (3 Pages)



OXNARD SCHOOL DISTRICT

1051 South "A" Street • Oxnard, California 93030 • (805) 385-1501

AGREEMENT FOR NONPUBLIC, NONSECTARIAN SCHOOLING

AGREEMENT #17-296

THIS AGREEMENT, made and entered into this 2nd day of May 2018 by and between the OXNARD SCHOOL DISTRICT, hereinafter referred to as the District, and the ASSISTANCE LEAGUE SCHOOL, hereinafter referred to as the nonpublic, nonsectarian school.

WITNESSETH:

WHEREAS, the District is authorized by the provisions of the California Education Code, Section 56155 et seq., to contract with a nonpublic, nonsectarian school to provide services for certain pupils who are unable to benefit from regular education; and

WHEREAS, the District has determined, through evaluation and individual educational plans, that the following pupils are in need of such services;

Grade: Pre-K (3)

AV100514 (5 months)

GB013114 (5 months)

JS100214 (4 months)

NOW, THEREFORE, in consideration of their mutual promises contained herein, the parties hereto enter into a fixed price contract as follows:

1. The nonpublic school will provide a program of instruction which is consistent with the pupil's individual educational plan as specified in the individual service agreement attached hereto and made a part hereof, and that the nonpublic, nonsectarian schools basic educational program and designated instruction and services shall be described in a written statement to be provided to the school district prior to the execution of this agreement.

2. The services shall be provided for the **2017--2018** school year at a cost of \$850.00 per month, per student, two students at 5 months each and one student at 4 months, beginning February 2018, including Extended School Year (ESY) through July 2018; amount not to exceed **\$11,900.00.**

3. The nonpublic school shall keep attendance of each pupil daily and shall report attendance monthly to the school district. Such attendance records shall be kept in a California State school register and copies of such register shall be filed with monthly invoices to the district within thirty (30) days after the close of the school month. Separate attendance registers shall be submitted for all designated instruction and services.

4. The nonpublic school will notify the school district of any change in a pupil's placement and/or address within three (3) days after the nonpublic school is informed of such changes.

5. The nonpublic school will report within three (3) days to the school district if a pupil is removed from the school by the placement agency, parent or legal guardian, or if a pupil absents himself/herself from school without permission for more than five (5) consecutive school days. For the purposes of the contract, a parent is the natural or adoptive parent, legal guardian or surrogate parent appointed by the district of residence when the courts have removed the parents educational rights.

6. The nonpublic school shall notify the school district when a pupil is absent for five (5) consecutive school days because of illness. Notification will be in writing.

7. *The nonpublic school will not be paid for excused absences due to changes in the ADA laws. These absences shall count as non-instructional days and not compensated at the daily rate.*

8. The nonpublic school shall prepare and submit to the school district trimester progress reports, incident reports within 24 hours, year-end reports and other data required for the annual review on or before April 15th of the current school year. Forms for year-end and other required reports shall be provided by the school district via the computerized special education support program (SESP).

9. In consideration of the services to be rendered by the nonpublic, nonsectarian school, the district agrees to payment as follows:

All cost for this service, including intake, testing, tuition, and elective shall not exceed **\$11,900.00** for students listed on page one of this Agreement #17-296.

10. While engaged in carrying out and complying with the terms of this agreement, the nonpublic, nonsectarian school is an independent contractor and not an officer, agent, or employee of the district. The independent contractor will obtain a criminal record summary from the Department of Justice or a Department of Justice approved agency on all employees or contracted service providers who potentially have contact with students. This clearance will be completed prior to the person(s) first day of employment. No individual who has been convicted of a violent or serious felony as listed in subdivision C, of Section 1192.7 of the California Penal Code will be employed in any capacity that potentially involves contact with students. Nor will any person be employed who has been convicted of, or entered a plea of nolo contendere to charges of any sex offense as defined in Education Code 44011.

11. The school district may withhold payment to the nonpublic, nonsectarian school when, in the opinion of the district: (1) nonpublic school's performance in whole or in part, either has not been sufficient or is insufficiently documented, or: (2) nonpublic school has neglected, failed, or refused to provide information or to cooperate with the inspection, review or audit of the program conducted by nonpublic school or records relating thereto. The school district shall not withhold payments as specified in this paragraph unless the school district has notified the nonpublic,

nonsectarian school, in writing, that nonpublic, nonsectarian school has not performed as specified herein. The notice shall specify that nonpublic, nonsectarian school has fourteen (14) days to make the required corrections. If, after the expiration of the fourteen (14) days, nonpublic, nonsectarian school has not corrected the situation as specified in the district's notice, the affected payments will be withheld and this agreement may be canceled for cause.

12. During the entire term of this agreement and any extension or modification thereof, the nonpublic school shall keep in effect a policy or policies of liability insurance, including coverage of owned and non-owned automobiles operated by nonpublic school for the purposes of this agreement, of at least \$1,000,000 for each person and \$1,000,000 for each accident or occurrence from all damages arising out of death, bodily injury, sickness, or disease from any one accident or occurrence, and \$3,000,000 for all damages and liability arising out of injury to or destruction of property for each accident or occurrence. Not later than the effective date of this contract, the nonpublic school shall provide the District with satisfactory evidence of insurance, naming the District as additional insured, including a provision for a twenty (20) calendar day written notice to District before cancellation or material change, evidencing the above specified coverage. The Nonpublic school shall at its own cost and expense procure and maintain insurance under the Workers' Compensation Law of California. Said certificates shall specify that insurance shall not be canceled or changed in required limits unless the school district has been provided forty-five (45) days advance written notification of cancellation or change.

The nonpublic, nonsectarian school shall also maintain Workers' Compensation Insurance coverage as required by law.

13. This Agreement, or any of its rights, obligations, provisions, or conditions, may not be assigned by either party without the written consent of the party.

14. This Agreement may be amended by mutual agreement of the parties and may be terminated by either party upon twenty (20) days advance notification.

IN WITNESS WHEREOF, the parties hereto have set their hands on the day and year first above written.

Date

Lisa A. Franz, Director, Purchasing
Oxnard School District

Date

Victoria Elliott, Director
Assistance League School, Nonpublic, Nonsectarian School

OSD BOARD AGENDA ITEM

Name of Contributor: Robin Freeman

Date of Meeting: 5/2/18

- Study Session: _____
Closed Session _____
A-1. Preliminary _____
A-II. Reports _____
B. Hearings _____
C. Consent Agenda _____
- Agreement Category:
____ Academic
____ Enrichment
 X Special Education
____ Support Services
____ Personnel
____ Legal
____ Facilities
- D. Action Items _____
F. Board Policies 1st Reading _____ 2nd Reading _____

Ratification of Agreement #17-302 - Ventura County Office of Education, Special Circumstances Paraeducator Services - SCP (Freeman/Sugden)

It is recommended that the Board of Trustees ratify the service agreements with Ventura County Office of Education (VCOE) for the 2017-2018 school year, to provide exceptional services to special education students that consist of support from Special Circumstances Paraeducators (SCP's), including Extended School Year.

Students 2017-2018:

| | | | |
|-----------------|--------------|-----------------|--------------|
| OL083008 | \$ 17,306.80 | RR103108 | \$ 17,091.20 |
| AC070205 | \$ 19,168.80 | IR033009 | \$ 11,730.60 |

FISCAL IMPACT:

\$65,297.40 - Special Education Funds

RECOMMENDATION:

It is the recommendation of the Director, Special Education Services, and the Assistant Superintendent, Educational Services, that the Board of Trustees ratify Agreement #17-302 with the Ventura County Office of Education for Special Circumstances Paraeducator Services (SCP's), in the amount of \$65,297.40.

ADDITIONAL MATERIAL(S):

Attached: Agreement #17-302, Ventura County Office of Education (4 Pages)



AGREEMENT

For Paraeducator Performing Special Circumstance Educational Support

This Agreement, effective February 23, 2018 is made by and between the Ventura County Office of Education, hereinafter referred to as SUPERINTENDENT, and the Oxnard School District, hereinafter referred to as DISTRICT.

1. This agreement pertains to providing exceptional service(s) for, OL083008, a Special Education pupil who is a resident of DISTRICT and currently attends Penfield School a special education program operated by SUPERINTENDENT.
2. SUPERINTENDENT agrees to provide for the exceptional service(s) of such Special Education pupil as authorized by DISTRICT or its designee and agreed to by SUPERINTENDENT.
3. DISTRICT shall reimburse SUPERINTENDENT the actual cost of providing the exceptional service plus the state approved indirect cost rate of SUPERINTENDENT.

Authorized exceptional service(s) shall consist of Paraeducator performing special circumstance support throughout the school day for a total of 330 minutes a day. ESY will be provided at 240 minutes a day.

4. DISTRICT acknowledges that certain types of expenses will continue to accrue during periods of student's absence from school, including but not limited to salary and benefits of staff providing the exceptional service(s). DISTRICT further acknowledges that if the exceptional service(s) includes the service(s) of SUPERINTENDENT's employee(s), 45 days' notice is required to layoff an employee for lack of work. Therefore, in the event the student unexpectedly leaves SUPERINTENDENT's program, SUPERINTENDENT will make every attempt to re-assign any staff involved in providing the exceptional service(s); however, if that is not possible, DISTRICT will reimburse SUPERINTENDENT for expense incurred throughout the layoff notice period.
5. DISTRICT does hereby agree to defend, indemnify and hold harmless the SUPERINTENDENT, the Ventura County Board of Education, and its officers, and employees from any and all claims, demands, liabilities, expenses (including attorneys' fees and costs of defense) arising as a result of SUPERINTENDENT's obligations under this agreement. However, this indemnification shall not apply if it is ultimately adjudicated that such claim, demand, liability or expense arose out of the sole negligence of the SUPERINTENDENT.
6. The term of this contract shall begin 2/23/2018 (IEP date) and continue thereafter on a continuing basis until the IEP of said student is modified or until student's district of residence changes.

| | | |
|--------------------------------|---|----------------------------|
| FISCAL YEAR-based on IEP date: | CURRENT: <u>2017-2018</u> <u>2/23/2018-6/14/2018</u> (ESY: <u>6/18/2018-6/29/2018</u>) | UPCOMING: <u>2018-2019</u> |
| (including ESY, if applicable) | \$ <u>17,306.80</u> | + \$ <u>TBA</u> |

It shall be the responsibility of DISTRICT to notify SUPERINTENDENT of any change in district of residence or change in the IEP that would affect this contract.

IN WITNESS WHEREOF, the parties hereto have executed this agreement:

OXNARD SCHOOL DISTRICT

VENTURA COUNTY OFFICE OF EDUCATION

Signature Lisa A. Franz

Accepted By: [Signature]
Special Education Authorized Representative

Title: Director, Purchasing

Approved By: _____
Business Services Authorized Representative

Date: _____

Date: _____

Estimated Cost \$ 17,306.80

Please submit **two** original copies Oxnard School District-Purchasing Department



AGREEMENT

For Paraeducator Performing Special Circumstance Educational Support

This Agreement, effective February 24, 2018 is made by and between the Ventura County Office of Education, hereinafter referred to as SUPERINTENDENT, and the Oxnard School District, hereinafter referred to as DISTRICT.

1. This agreement pertains to providing exceptional service(s) for, RR103108, a Special Education pupil who is a resident of DISTRICT and currently attends, Penfield School a special education program operated by SUPERINTENDENT.
2. SUPERINTENDENT agrees to provide for the exceptional service(s) of such Special Education pupil as authorized by DISTRICT or its designee and agreed to by SUPERINTENDENT.
3. DISTRICT shall reimburse SUPERINTENDENT the actual cost of providing the exceptional service plus the state approved indirect cost rate of SUPERINTENDENT.

Authorized exceptional service(s) shall consist of Paraeducator performing special circumstance educational support throughout the school day for a total of 330 minutes a day. ESY will be provided at 240 minutes a day.

4. DISTRICT acknowledges that certain types of expenses will continue to accrue during periods of student's absence from school, including but not limited to salary and benefits of staff providing the exceptional service(s). DISTRICT further acknowledges that if the exceptional service(s) includes the service(s) of SUPERINTENDENT's employee(s), 45 days' notice is required to layoff an employee for lack of work. Therefore, in the event the student unexpectedly leaves SUPERINTENDENT's program, SUPERINTENDENT will make every attempt to re-assign any staff involved in providing the exceptional service(s); however, if that is not possible, DISTRICT will reimburse SUPERINTENDENT for expense incurred throughout the layoff notice period.
5. DISTRICT does hereby agree to defend, indemnify and hold harmless the SUPERINTENDENT, the Ventura County Board of Education, and its officers, and employees from any and all claims, demands, liabilities, expenses (including attorneys' fees and costs of defense) arising as a result of SUPERINTENDENT's obligations under this agreement. However, this indemnification shall not apply if it is ultimately adjudicated that such claim, demand, liability or expense arose out of the sole negligence of the SUPERINTENDENT.
6. The term of this contract shall begin 2/24/2018 (IEP date) and continue thereafter on a continuing basis until the IEP of said student is modified or until student's district of residence changes.

| | | |
|--|--|----------------------------|
| FISCAL YEAR-based on IEP date: (including ESY, if applicable) | CURRENT: <u>2017-2018</u> <u>2/24/2018-6/7/2018</u> (ESY: <u>6/11/2018-6/29/2018</u>) | UPCOMING: <u>2018-2019</u> |
| | \$ <u>17,091.20</u> | + |

It shall be the responsibility of DISTRICT to notify SUPERINTENDENT of any change in district of residence or change in the IEP that would affect this contract.

IN WITNESS WHEREOF, the parties hereto have executed this agreement:

OXNARD SCHOOL DISTRICT

VENTURA COUNTY OFFICE OF EDUCATION

Signature Lisa A. Franz

Accepted By: [Signature]
Special Education Authorized Representative

Title: Director, Purchasing

Approved By: _____
Business Services Authorized Representative

Date: _____

Date: _____

Estimated Cost \$ 17,091.20

Please submit **two** original copies Oxnard School District-Purchasing Department



AGREEMENT

For Paraeducator Performing Special Circumstance Educational Support

This Agreement, effective February 1, 2018 is made by and between the Ventura County Office of Education, hereinafter referred to as SUPERINTENDENT, and the Oxnard School District, hereinafter referred to as DISTRICT.

1. This agreement pertains to providing exceptional service(s) for, AC070205 a Special Education pupil who is a resident of DISTRICT and currently attends, Foster School a special education program operated by SUPERINTENDENT.
2. SUPERINTENDENT agrees to provide for the exceptional service(s) of such Special Education pupil as authorized by DISTRICT or its designee and agreed to by SUPERINTENDENT.
3. DISTRICT shall reimburse SUPERINTENDENT the actual cost of providing the exceptional service plus the state approved indirect cost rate of SUPERINTENDENT.

Authorized exceptional service(s) shall consist of Paraeducator performing special circumstance educational support throughout the school day for a total of 330 minutes a day. ESY will be provided at 240 minutes a day.

4. DISTRICT acknowledges that certain types of expenses will continue to accrue during periods of student's absence from school, including but not limited to salary and benefits of staff providing the exceptional service(s). DISTRICT further acknowledges that if the exceptional service(s) includes the service(s) of SUPERINTENDENT's employee(s), 45 days' notice is required to layoff an employee for lack of work. Therefore, in the event the student unexpectedly leaves SUPERINTENDENT's program, SUPERINTENDENT will make every attempt to re-assign any staff involved in providing the exceptional service(s); however, if that is not possible, DISTRICT will reimburse SUPERINTENDENT for expense incurred throughout the layoff notice period.
5. DISTRICT does hereby agree to defend, indemnify and hold harmless the SUPERINTENDENT, the Ventura County Board of Education, and its officers, and employees from any and all claims, demands, liabilities, expenses (including attorneys' fees and costs of defense) arising as a result of SUPERINTENDENT's obligations under this agreement. However, this indemnification shall not apply if it is ultimately adjudicated that such claim, demand, liability or expense arose out of the sole negligence of the SUPERINTENDENT.
6. The term of this contract shall begin 2/1/2018 (IEP date=11/7/2017) and continue thereafter on a continuing basis until the IEP of said student is modified or until student's district of residence changes.

| | | |
|--|---|----------------------------|
| FISCAL YEAR-based on IEP date: (including ESY, if applicable) | CURRENT: <u>2017-2018</u> <u>2/1/2018-6/8/2018</u> (ESY: <u>6/11/2018-6/29/2018</u>) | UPCOMING: <u>2018-2019</u> |
| | \$ <u>19,168.80</u> | + |

It shall be the responsibility of DISTRICT to notify SUPERINTENDENT of any change in district of residence or change in the IEP that would affect this contract.

IN WITNESS WHEREOF, the parties hereto have executed this agreement:

OXNARD SCHOOL DISTRICT

VENTURA COUNTY OFFICE OF EDUCATION

Signature Lisa A. Franz

Accepted By: [Signature]
Special Education Authorized Representative

Title: Director, Purchasing

Approved By: _____
Business Services Authorized Representative

Date: _____

Date: _____

Estimated Cost \$ 19,168.80

Please submit **two** original copies Oxnard School District-Purchasing Department



AGREEMENT

For Paraeducator Performing Special Circumstance Educational Support

This Agreement, effective **March 5, 2018** is made by and between the Ventura County Office of Education, hereinafter referred to as SUPERINTENDENT, and the Oxnard School District, hereinafter referred to as DISTRICT.

1. This agreement pertains to providing exceptional service(s) for, **IR033009**, a Special Education pupil who is a resident of DISTRICT and currently attends Phoenix- Los Nogales School a special education program operated by SUPERINTENDENT.
2. SUPERINTENDENT agrees to provide for the exceptional service(s) of such Special Education pupil as authorized by DISTRICT or its designee and agreed to by SUPERINTENDENT.
3. DISTRICT shall reimburse SUPERINTENDENT the actual cost of providing the exceptional service plus the state approved indirect cost rate of SUPERINTENDENT.

Authorized exceptional service(s) shall consist of Paraeducator performing Special Circumstances Educational Support throughout the school day, 1560 minutes a week.

4. DISTRICT acknowledges that certain types of expenses will continue to accrue during periods of student's absence from school, including but not limited to salary and benefits of staff providing the exceptional service(s). DISTRICT further acknowledges that if the exceptional service(s) includes the service(s) of SUPERINTENDENT's employee(s), 30 days' notice is required to layoff an employee for lack of work. Therefore, in the event the student unexpectedly leaves SUPERINTENDENT's program, SUPERINTENDENT will make every attempt to re-assign any staff involved in providing the exceptional service(s); however, if that is not possible, DISTRICT will reimburse SUPERINTENDENT for expense incurred throughout the layoff notice period.
5. DISTRICT does hereby agree to defend, indemnify and hold harmless the SUPERINTENDENT, the Ventura County Board of Education, and its officers, and employees from any and all claims, demands, liabilities, expenses (including attorneys' fees and costs of defense) arising as a result of SUPERINTENDENT's obligations under this agreement. However, this indemnification shall not apply if it is ultimately adjudicated that such claim, demand, liability or expense arose out of the sole negligence of the SUPERINTENDENT.
6. The term of this contract shall begin 3/5/2018 (IEP date), and continue thereafter on a continuing basis until the IEP of said student is modified or until student's district of residence changes.

| | | | |
|--|--|---|----------------------------|
| FISCAL YEAR-based on IEP date: (including ESY, if applicable) | CURRENT: <u>2017-2018</u> <u>3/5/2018-5/31/2018</u> | | UPCOMING: <u>2018-2019</u> |
| | \$ <u>11,730.60</u> | + | \$ _____ |

It shall be the responsibility of DISTRICT to notify SUPERINTENDENT of any change in district of residence or change in the IEP that would affect this contract.

IN WITNESS WHEREOF, the parties hereto have executed this agreement:

OXNARD SCHOOL DISTRICT

VENTURA COUNTY OFFICE OF EDUCATION

Signature **Lisa A. Franz**

Accepted By: _____
Special Education Authorized Representative

Title: **Director, Purchasing**

Approved By: _____
Business Services Authorized Representative

Date: _____

Date: _____

Estimated Cost \$ 11,730.60

Please submit **two** original copies Oxnard School District-Purchasing Department

OSD BOARD AGENDA ITEM

Name of Contributor: **Dr. Jesus Vaca**

Date of Meeting: **May 2, 2018**

- A. Preliminary _____
Study Session _____
Report _____
- B. Hearing: _____
- C. Consent Agenda X
Agreement Category: ___ Academic
 ___ Enrichment
 ___ Special Education
 ___ Support Services
 ___ Personnel
 ___ Legal
 ___ Facilities
- D. Action Items _____
- E. Approval of Minutes _____
- F. Board Policies 1st Reading _____ 2nd Reading _____

Approval to Set Date for Notice of Public Hearing re: Sunshine of the Oxnard Supportive Services Association (OSSA) and the Oxnard School District's (District) Initial Proposals for 2018-2019 Negotiations, Pursuant to Government Code Section 3547 (Vaca)

EXECUTIVE SUMMARY (description of item):

In accordance with Article 22, Term, of the current collective bargaining agreement between the Oxnard Support Services Association (OSSA) and the Oxnard School District (District), the District and OSSA would like to enter into contract negotiations for the 2018-2019 school year and any additional years as may be mutually agreed upon by the parties. Pursuant to the provisions of Government Code Section 3547, OSSA and the District are submitting their intent to meet the public notice provision of the Educational Employment Rights Act. The proposals must have a Public Hearing before the parties meet to negotiate the items below:

- Article 8 Student Ratio
- Article 9 Evaluations
- Article 11 Leave Provisions
- Article 16 Salaries
- Article 18 Fringe Benefits
- Article 22 Term

FISCAL IMPACT:

None

RECOMMENDATION:

It is the recommendation of the Assistant Superintendent of Human Resources that the Board schedule May 16, 2018 for the Public Hearing for OSSA and the District's proposals.

ADDITIONAL MATERIAL(S):

- Letter to Board of Trustees President dated 4/20/18 (one page)
- Letter to OSSA President dated 4/20/18 (one page)
- District's Initial Bargaining Proposals to OSSA for 2018-19 (one page)
- Letter dated 4/18/18 from OSSA President to the District (one page)



OXNARD SCHOOL DISTRICT

1051 South "A" Street • Oxnard, California 93030 • 805/385-1501 • www.oxnardsd.org

April 20, 2018

Debra M. Cordes, President
Board of Trustees
Oxnard School District
1051 South A Street
Oxnard, California 93030

Re: Sunshine of OSSA and District Initial Proposals, 2018-19

Dear President Cordes,

In accordance with Article 22, Term, of the current collective bargaining agreement between the Oxnard Supportive Services Association (OSSA) and the Oxnard School District (District), the District would like to enter into contract negotiations for the 2018-2019 school year and any additional years as may be mutually agreed upon by the parties.

The District is looking forward to again working collaboratively with OSSA continuing the use of the Interest Based Problem Solving method, during negotiations, to address issues that arise by either party. The District's negotiating team will include:

Dr. Jesus Vaca, Assistant Superintendent and Lead Negotiator
Janet Penanhoat, Assistant Superintendent, Business Services
Dr. Edd Bond, Director, Certificated HR
Luis Ramirez, Principal
Chris Ridge, Director, Pupil Services
Amelia Sugden, Director, Special Education

Pursuant to Article 22, Term, in the current District/OSSA bargaining agreement, the current agreement expires on June 30, 2019. The District plans to negotiate Article 11 (Leave Provisions), Article 16 (Salaries), Article 18 (Fringe Benefits), and Article 22 (Term).

Pursuant to the provisions of Government Code Section 3547, the District is submitting its intent to meet the public notice provision of the Educational Employment Relations Act. The notice to set the public hearing will be on the May 2, 2018 Board agenda with the Public Hearing to be scheduled on May 16, 2018. Upon completion of the public notice provisions, the District looks forward to initiating a good faith bargaining effort with OSSA and continuing the use of the Interest Based Problem Solving approach to discuss these articles.

Sincerely,

DR. JESUS VACA
Assistant Superintendent
Human Resources and Support Services

JV/pp



OXNARD SCHOOL DISTRICT

1051 South "A" Street • Oxnard, California 93030 • 805/385-1501 • www.oxnardsd.org

April 20, 2018

Ms. Brenda Muth
Oxnard Supportive Services Association President
c/o Oxnard School District
1051 South A Street
Oxnard, California 93030

Re: Sunshine of OSSA and District Initial Proposals, 2018-19

Dear Ms. Muth,

In accordance with Article 22, Term, of the current collective bargaining agreement between the Oxnard Supportive Services Association (OSSA) and the Oxnard School District (District), the District would like to enter into contract negotiations for the 2018-2019 school year and any additional years as may be mutually agreed upon by the parties.

The District is looking forward to again working collaboratively with OSSA and continuing the use of the Interest Based Problem Solving method, during negotiations to address issues that arise by either party. The District negotiating team will include:

Dr. Jesus Vaca, Assistant Superintendent and Lead Negotiator
Janet Penanhoat, Assistant Superintendent, Business Services
Dr. Edd Bond, Director, HR
Luis Ramirez, Principal
Chris Ridge, Director, Pupil Services
Amelia Sugden, Director, Special Education

Pursuant to Article 22, Term, in the current District/OSSA bargaining agreement, the current agreement expires on June 30, 2019. The District plans to negotiate Article 11 (Leave Provisions), Article 16 (Salaries), Article 18 (Fringe Benefits), and Article 22 (Term).

Pursuant to the provisions of Government Code Section 3547, the District is submitting its intent to meet the public notice provision of the Educational Employment Relations Act. The notice to set the public hearing will be on the May 2, 2018 board meeting agenda and the Public Hearing is to be scheduled for May 16, 2018. Upon completion of the public notice provisions, the District looks forward to initiating a good faith bargaining effort with OSSA and continuing the use of the Interest Based Problem Solving approach to discuss these articles.

Sincerely,

DR. JESUS VACA
Assistant Superintendent
Human Resources and Support Services

JV/pp

Enclosure



OXNARD SCHOOL DISTRICT

1051 South "A" Street • Oxnard, California 93030 • 805/385-1501 • www.oxnardsd.org

Dr. Jesus Vaca
Assistant Superintendent
Human Resources and Support Services

Steve Bailey, Interim
Director, Classified Human Resources

Oxnard School District
Initial Sunshine Proposals to the
Oxnard Supportive Services Association
2018-19

Interest Based Problem Solving Proposals

The District seeks to discuss and solve issues relating to a variety of District and OSSA practices. The following contract articles are proposed for discussion:

Article 11 Leave Provisions

- The District seeks to enter into discussions regarding the OSSA Leave Provisions.

Article 16 Salaries

- The District seeks to enter into discussions regarding OSSA Salaries.

Article 18 Fringe Benefits

- The District seeks to enter into discussions regarding OSSA Fringe Benefits.

Article 22 Term

- The District seeks to enter into discussions regarding OSSA Term.



April 18, 2018

Dr. Jesus Vaca
Assistant Superintendent of Human Resources
Oxnard School District

Dear Dr. Vaca,

In accordance with Article 22- Term of the current collective bargaining agreement between the Oxnard School District and the Oxnard Supportive Services Association, and pursuant to the Educational Employment Relations Act (EERA), the Association is pleased to inform you of our intent to enter into contract negotiations with the Oxnard School District for the 2018-2019 contract year. OSSA is respectfully requesting to meet and negotiate collaboratively with the District and IBB Facilitator Bridgette Bodine.

The Association is looking forward to the continuing implementation of Interest Based Bargaining (IBB) process during negotiations and we are committed to the utilization of a bargaining process that maximizes our opportunity for creative and positive solutions to our mutual problems. We are further committed to problem solving in ways which value the contributions of the negotiators and support one another in finding ways to improve the lives of our mutual constituencies including students, parents, staff and the Oxnard community. The members of the OSSA negotiating team are: Brenda Muth, Jose Carranza, Lauren Kaprielian, Annette Murguia, Steve Tobey, Monica Garcia and Irene Zavala.

The Association seeks to open the following articles:

Article 9 – Evaluations – The Association seeks discussion regarding Evaluation procedures.

In accordance with our agreement, Article 8 will be an automatic reopen for 2018-19 contract negotiations.

Article 8 – Student Ratio - The Association seeks discussion regarding Student Ratios.

Sincerely,

Brenda Muth, President
Oxnard Support Services Association

BOARD AGENDA ITEM

Name of Contributor: Janet Penanhoat

Date of Meeting: May 2, 2018

STUDY SESSION _____

CLOSED SESSION _____

SECTION A-I: PRELIMINARY _____

SECTION A-II: REPORTS _____

SECTION B: HEARINGS _____

SECTION C: CONSENT AGENDA _____

X

Agreement Category:

_____ Academic

_____ Enrichment

_____ Special Education

_____ Support Services

_____ Personnel

_____ Legal

_____ Facilities

SECTION D: ACTION _____

SECTION F: BOARD POLICIES 1ST Reading _____ 2nd Reading _____

APPROVAL OF RESOLUTION #17-40: DESIGNATION OF APPLICANT'S AGENT RESOLUTION FOR NON-STATE AGENCIES (Penanhoat/Magaña)

In conjunction with the Ventura County Schools Self-Funding Authority (VCSSFA), the Administration has submitted a Request for Public Assistance (RPA) to the Governor's Office of Emergency Services (OES) to obtain federal and state financial assistance made available as a result of the 2017 California Wildfires. The OES requires that the Board of Trustees designate via resolution those agents authorized to act on behalf of the District for all matters pertaining to federal and state financial assistance. Said agents will execute all necessary documents for and on behalf of the Oxnard School District (OSD). The Administration proposes that the following agents be designated:

- Janet Penanhoat, Assistant Superintendent, Business & Fiscal Services, OSD
- Norma Magaña, Risk Manager, OSD
- Russ Olsen, Director, Risk Management, VCSSFA

Resolution #17-40 is presented herewith for the Board's consideration.

FISCAL IMPACT

None.

RECOMMENDATION

It is the recommendation of the Assistant Superintendent, Business & Fiscal Services, and the Risk Manager, that the Board of Trustees approve Resolution #17-40 as presented.

ADDITIONAL MATERIAL

Attached: Resolution #17-40 (1 page)

OSD RESOLUTION #17-40

DESIGNATION OF APPLICANT'S AGENT RESOLUTION FOR NON-STATE AGENCIES

BE IT RESOLVED BY THE _____ OF THE _____
(Governing Body) (Name of Applicant)

THAT _____, OR
(Title of Authorized Agent)

_____, OR
(Title of Authorized Agent)

(Title of Authorized Agent)

is hereby authorized to execute for and on behalf of the _____, a public entity
(Name of Applicant)

established under the laws of the State of California, this application and to file it with the California Governor's Office of Emergency Services for the purpose of obtaining certain federal financial assistance under Public Law 93-288 as amended by the Robert T. Stafford Disaster Relief and Emergency Assistance Act of 1988, and/or state financial assistance under the California Disaster Assistance Act.

THAT the _____, a public entity established under the laws of the State of California,
(Name of Applicant)

hereby authorizes its agent(s) to provide to the Governor's Office of Emergency Services for all matters pertaining to such state disaster assistance the assurances and agreements required.

Please check the appropriate box below:

This is a universal resolution and is effective for all open and future disasters up to three (3) years following the date of approval below.

This is a disaster specific resolution and is effective for only disaster number(s) _____

Passed and approved this 2nd day of May, 2018

Debra M. Cordes, President, Oxnard School District Board of Trustees

(Name and Title of Governing Body Representative)

Dr. Cesar Morales, Superintendent, Oxnard School District

(Name and Title of Governing Body Representative)

(Name and Title of Governing Body Representative)

CERTIFICATION

I, **Ernie "Mo" Morrison**, duly appointed and **Clerk of the Board of Trustees** of
(Name) (Title)

Oxnard School District, do hereby certify that the above is a true and correct copy of a
(Name of Applicant)

Resolution passed and approved by the **Board of Trustees** of the **Oxnard**
(Governing Body) (Name of Applicant)

on the 2nd day of May, 2018.

(Signature)

Clerk of the Board of Trustees

(Title)

OSD BOARD AGENDA ITEM

Name of Contributor: **Dr. Jesus Vaca/Steve Bailey**

Date of Meeting: **May 2, 2018**

- A. Preliminary _____
Study Session _____
Report _____
- B. Hearing: _____
- C. Consent Agenda X
Agreement Category:
 - _____ Academic
 - _____ Enrichment
 - _____ Special Education
 - _____ Support Services
 - _____ Personnel
 - _____ Legal
 - _____ Facilities
- D. Action Items _____
- E. Approval of Minutes _____
- F. Board Policies 1st Reading _____ 2nd Reading _____

Personnel Actions (Vaca/Bailey)

The attached are recommended Personnel Actions presented to the Board of Trustees for consideration. The salary placement for the individuals employed will be in accordance with the salary regulations of the District. Personnel Actions include: new hires, transfers, pay changes, layoffs, recall from layoffs, resignations, retirements, authorizations, and leaves of absence.

FISCAL IMPACT:

N/A

RECOMMENDATION:

It is the recommendation of the Assistant Superintendent, Human Resources & Support Services and the Interim Director, Classified Human Resources, that the Board of Trustees approve the Personnel Actions, as presented.

ADDITIONAL MATERIAL:

- Classified Personnel Actions (one page)
- Certificated Personnel Actions (one page)

CLASSIFIED PERSONNEL ACTIONS

New Hire

| | | |
|--------------------|--|------------|
| Ayala, Elizabeth G | Paraeducator III, Position #7999 Special Education 5.75 hrs./183 days | 04/09/2018 |
|--------------------|--|------------|

Limited Term

| | | |
|-------------------|------------------------|------------|
| Acevedo, Maria D | Child Nutrition Worker | 04/09/2018 |
| Diaz, Juan | Paraeducator | 03/05/2018 |
| Hernandez, Olivia | Paraeducator | 04/09/2018 |

Transfer

| | | |
|-------------------|--|------------|
| Cortez, Claudia | Secretary (B), Position #922 Enrollment Center 8.0 hrs./246 days Intermediate School Secretary (B), Position #933 Frank 8.0 hrs./192 days | 04/23/2018 |
| Santos, Alejandra | Family Liaison (B), Position #8180 Special Education 8.0 hrs./180 days Family Liaison (B), Position #6405 Ramona 6.0 hrs./180 days | 04/30/2018 |

Resignation

| | | |
|--------------------|--|------------|
| Pina Robles, Mayra | Paraeducator I (B), Position #7378 English Learner Services 5.5 hrs./183 days | 04/27/2018 |
|--------------------|--|------------|

Retirement

| | | |
|-----------------------------|---|------------|
| Bribiesca Sifuentes, Isidro | Custodian, Position #2399 | 06/29/2018 |
| Vargas, Jennie A | Speech Language Pathology Assistant, Position #2858 | 06/14/2018 |

CERTIFICATED PERSONNEL ACTIONS

Listed below are recommended Certificated Personnel Actions presented to the Board of Trustees for consideration. The salaries for the individuals employed will be determined, in accordance with the salary regulations of the District.

New Hires

| | | |
|------------------------|---------------------|-----------------------|
| Alvarado, Kayla | Teacher | 08/14/2018 |
| Becerra Guadalupe | Teacher, SPED M/M | 08/14/2018 |
| Carter, Kaitlin | School Psychologist | 08/04/2018 |
| Kernochan, Brian | Teacher SPED M/M | 04/20/2018 |
| Leon, Almacynthia | Teacher, SPED M/M | 08/14/2018 |
| Reyes Rodriguez, Wendy | Teacher, SPED M/S | 08/14/2018 |
| | | |
| Larson, Patricia | Substitute Teacher | 2017/2018 School Year |
| Rodriguez, Maria | Substitute Teacher | 2017/2018 School Year |
| Smithson, Arnett | Substitute Teacher | 2017/2018 School Year |
| Wells, Ryan | Substitute Teacher | 2017/2018 School Year |

Resignation

| | | |
|------------------|--------------------|---------------|
| Guerrero, Noheli | Psychologist, SPED | June 22, 2018 |
|------------------|--------------------|---------------|

BOARD AGENDA ITEM

Name of Contributor: Janet Penanhoat

Date of Meeting: 5/2/18

- STUDY SESSION** _____
- CLOSED SESSION** _____
- SECTION A-1: PRELIMINARY** _____
- SECTION A-II: REPORTS** _____
- SECTION B: HEARINGS** _____
- SECTION C: CONSENT AGENDA** _____

- X** Agreement Category:
____ Academic
____ Enrichment
____ Special Education
____ Support Services
____ Personnel
____ Legal
____ Facilities

SECTION D: ACTION _____
SECTION F: BOARD POLICIES 1st Reading _____ 2nd Reading _____

Approval of a Contractor Contingency Allocation No. 001 to the Marshall New Classroom Building Project’s Contractor Contingency for an increase of cost for the Work associated with the Project (Penanhoat/Fateh/CFW)

The Oxnard School District (“District”) Board of Trustees (“Board”) Facilities Implementation Plan first adopted in January 2013, calls for the construction of the new classroom building at Marshall School (“Project”). The Project includes the construction of a new school building at the existing Marshall School site.

During the Regular Meeting of August 23, 2017, the Board of Trustees Approved Item C-12, the Construction Services Agreement between the Oxnard School District and Bernards for the Project. During that Meeting, the inclusion of a Three Hundred Forty-Five Thousand Nine Hundred Thirty-Two Dollars and No Cents (\$345,932.00) Contractor Contingency was explained. The Contractor Contingency is for payment of very specific items of Work: (1) additional costs resulting from discrepancies in the bid buy-out process; (2) conflicts, discrepancies or errors in the Construction Documents; (3) work required by the Inspector of Record or any governmental agency involved with the permitting or approval/certification process that is not otherwise shown in the Construction Documents; and (4) any other items of cost agreed to in writing by the Contractor and District to be included in the Contractor Contingency.

Contractor Contingency Allocation No. 001 provides for the Board’s approval of seven (7) items of cost agreed to in writing by the Contractor and District to be drawn from the Contractor Contingency. Contractor Contingency Allocation No. 001 will not increase Contract Time.

FISCAL IMPACT

Contractor Contingency Allocation No. 001 will be a **COST** to the Contractor Contingency line item of the GMP Construction Services Agreement in the amount of **Thirty-Two Thousand Seven Hundred Fourteen Dollars and No Cents (\$32,714.00)** to be drawn from the Master Construct and Implementation Funds.

The Contractor Contingency is included within the approved total of the Construction Services Agreement for the Marshall New Classroom Building Project. The remaining Contractor Contingency balance after Allocation No. 001 will be **Three Hundred Thirteen Thousand Two Hundred Eighteen Dollars and No Cents (\$313,218.00)**.

RECOMMENDATION

It is the recommendation of the Assistant Superintendent, Business & Fiscal Services, and the Director of Facilities, in conjunction with Caldwell Flores Winters, Inc., that the Board of Trustees approve Contingency Allocation No. 001 to Construction Services Agreement #17-117 with Bernards, for additional items of Work related to the Marshall New Classroom Building Project.

ADDITIONAL MATERIAL

Attached:

- *Contractor Contingency Allocation No. 001, Bernards (3 Pages)*
- *COR No. 3 (8 Pages)*
- *COR No. 10 (21 Pages)*
- *COR No. 12 (12 Pages)*
- *COR No. 13 (5 Pages)*
- *COR No. 14 (40 Pages)*
- *COR No. 15 (20 Pages)*
- *COR No. 17 (10 Pages)*
- *Construction Services Agreement # 17-117 (115 Pages)*



CONTRACTOR CONTINGENCY ALLOCATION APPROVAL

Date: May 2, 2018

CONTRACTOR CONTINGENCY ALLOCATION NO. 001

PROJECT: MARSHALL NEW CLASSROOM BUILDING
O.S.D. BID No. N/A
O.S.D. Agreement No. 17-117

OWNER: Oxnard School District
1051 South A Street
Oxnard, CA. 93030

ARCHITECT CSDA Design Group
4061 Glencoe Ave., Suite B
Marina Del Rey, CA 90292

CONTRACTOR:

Bernards Bros. Inc.
555 First Street
San Fernando, CA 91340
Attn: Carl Magness

Architects Proj. No.: 1534.01
D.S.A. File No.: 56-22
D.S.A. App. No.: 03-116806

CONFORMANCE WITH CONTRACT DOCUMENTS, PROJECT MANUAL, DRAWINGS AND SPECIFICATION. All Contractor Contingency Allocation work shall be in strict conformance with the Contract Documents, Project Manual, Drawings, and Specifications as they pertain to work of a similar nature.

| | | |
|--|-----------|--------------------|
| ORIGINAL CONTRACTOR CONTINGENCY SUM | \$ | 345,932.00 |
| NET CHANGE – ALL PREVIOUS CONTRACTOR CONTINGENCY ALLOCATION | \$ | 0.00 |
| ADJUSTED CONTINGENCY SUM | \$ | 345,932.00 |
| NET CHANGE | \$ | 0.00 |
| <hr/> | | |
| Total Contingency Allocations to Date: | \$ | (32,714.00) |
| ADJUSTED CONTRACTOR CONTINGENCY SUM THROUGH NO.: 001..... | \$ | 313,218.00 |

| Item | Description | Additional Cost related to Bid/Buy-out | Conflicts, Discrepancies or Errors in the Construction Documents | Additional Work required by IOR, or another Jurisdictional Agency, not in plans | Other Item of Cost agreed to by District and Contractor |
|------|--|--|--|---|---|
| 1. | COR No. 3 – Per RFI 76 add ¾” condensate piping | | \$3154.00 | | |
| 2. | COR No. 10 – Change glass from ¼” to 1” per RFI 73 | | | 14923.00 | |
| 3. | COR No. 12 – Resurveying at playground | | \$5107.00 | | |
| 4. | COR No. 13 – CCD 12 Remove and replace rebar @ 34 & 35 | | | \$2606.00 | |
| 5. | COR No. 14 – CCD 08 Rebar | | | \$1429.00 | |
| 6. | COR No. 15 – Additional rebar for CCD 11 and 12 | | | \$3055.00 | |
| 7. | COR No. 17 – Per RFI 85 Redesign Science classroom 107, 109, 208 | | \$2440.00 | | |
| | | | | | |
| | Totals | | \$10701.00 | \$22013.00 | |

Total Contractor Contingency Allocation Approval No. 001 \$32,714.00

**NOT VALID UNTIL SIGNED BY THE ARCHITECT, CONTRACTOR AND ASST. SUPERINTENDENT OR PURCHASING DIRECTOR*

APPROVAL (REQUIRED):

ARCHITECT: _____

DATE: _____

CONTRACTOR: _____

DATE: _____

RECOMMENDED FOR APPROVAL:

DIRECTOR OF FACILITIES:

DATE: _____

APPROVAL (REQUIRED):

PURCHASING DIRECTOR: _____

DATE: _____



CHANGE ORDER REQUEST

COR No. 3 R0

Date: 1/25/2018

Project: Marshall Elementary - New 6-8 Classroom Bldg.

DESCRIPTION OF WORK

Per RFI 76 - Add 3/4" Condensate Piping due to relocated fancoil unit in 2nd floor electrical room.

SUMMARY OF COSTS

| Item Description | Company | Amount Requested |
|---|------------------------------|------------------|
| Subcontract Costs | | |
| Per RFI 76 - Add 3/4" Condensate Piping | City Commercial Plumbing Inc | 3,154 |
| | Subtotal: | 3,154 |
| Total Change Order Request Amount: | | 3,154 |

APPROVAL

(Please note that if this Change Order Request is not approved by , additional costs and schedule impacts may result.)

Oxnard School District

Bernards Bros. Inc.

Signature

Printed Name & Title

Date

Signature

Printed Name & Title

Date

Jennifer McIsaac
CFW Program Mgr.



CITY COMMERCIAL PLUMBING, INC.
Plumbing Contractors and Consultants

IN B320

OCO #3

16106 Cohasset St., Van Nuys, California 91406

(818) 785-1145

Fax: (818) 785-0588

EXTRA WORK ORDER SUBMITTAL

January 5, 2018

TO: BERNARDS

ATTENTION: CARL MAGNESS

JOB NAME: MARSHALL ELEMENTARY

EXTRA WORK ORDER NO: CCP Inc., C.O.R.#2

DESCRIPTION: RFI#76 - ADD 3/4" CONDENSATE PIPING DUE TO RELOCATED FANCOIL UNIT IN 2ND FLOOR ELECTRICAL ROOM.

TOTAL COST: \$3,154.00

Escalation rate of 1.5% / month will apply all unpaid change orders. Change order pricing assumes conditions existing as of date submitted. We reserve the right to adjust pricing if conditions change. Change orders should not be subject to retention. Request 1 days extension to complete this change order. We reserve the right to assess the cumulative impact of change.

This is the cost to add the scope to our contract. This proposal is void unless a written Change Order is received within 30 calendar days from the date of this Extra Work Order Submittal. Please send a Subcontract Change Order if you would like us to proceed with the extra work. This change order represents the work described only in this proposal. If the proposal is incomplete, we reserve the right to revise our price. We encourage you to review the scope of work we are offering to make sure it is in line with the changes.

If an owner-initiated change order is not accepted and authorized, City Commercial Plumbing demands reimbursement for all costs incurred in the preparation of the quote. If you have any questions or need clarification please call.

Sincerely,
CITY COMMERCIAL PLUMBING, INC

Cindy Snyder, Project Manager

Enclosures

CITY COMMERCIAL PLUMBING, INC.

16106 COHASSET STREET
 VAN NUYS, CA 91406
 (818) 785-1145

CONTRACTOR: BERNARDS
 555 FIRST STREET
 SAN FERNANDO, CA 91340

JOB NAME: MARSHALL ELEMENTARY
 2900 THURGOOD MARSHALL DR.
 OXNARD, CA 93036

CCP JOB NO.: 582
CHANGE ORDER NO. 2

RE: RFI#76 ADDED 3/4" CD PIPING FOR RELOCATED FANCOIL UNIT

| LABOR: | WAGES | HOURS | TOTAL |
|---|--------|-------|-------------------|
| GENERAL FOREMAN | 106.84 | 4.00 | 427.36 |
| PLUMBER | 90.35 | 16.00 | 1,445.60 |
| TOTAL LABOR: | | | 1,872.96 |
| OTHER EXPENSE: | | | |
| ZOLNAY INSULATION (INSULATION & FIRESTOPPING) | | | 530.88 |
| ZOLNAY INSURANCE COST | | | 57.00 |
| TOTAL OTHER EXP.: | | | 587.88 |
| OTHER EXPENSE: | | | 587.88 |
| MATERIAL TOTAL: | | | 276.72 |
| LABOR TOTAL: | | | 1,872.96 |
| SUBTOTAL: | | | 2,737.56 |
| OVERHEAD/PROFIT: | 15.00% | | 410.63 |
| SUBTOTAL: | | | 3,148.19 |
| TEXTURA FEES: | 0.18% | | 5.67 |
| SUBTOTAL: | | | 3,153.86 |
| | | | 3,153.86 |
| ROUND UP/DOWN: | | | \$3,154.00 |

NOTES:

CITY COMMERCIAL PLUMBING, INC.

MATERIAL LIST

JOB: MARSHALL ELEMENTARY
2900 THURGOOD MARSHALL DR.
OXNARD, CA 93036

CCP JOB NO.: 582
CHANGE ORDER NO. 2

RE: RFI#76 ADDED 3/4" CD PIPING FOR RELOCATED FANCOIL UNIT

| QTY. | U/M | MATERIAL NAME | LAB U. | T. LAB. | MAT.COST | T. MAT |
|------|-----|---|--------|---------|----------|--------|
| | | MATERIAL | | 14.00 | | 253.29 |
| | | ADDITIONAL LABOR: | | | | |
| | | CONNECTION TO PUMP | | 1.00 | | |
| | | LAYOUT SUBBONTRACTOR | | 1.00 | | |
| | | GENERAL FOREMAN - ENGINNER/COORDINATE/LAYOU | | 4.00 | | |

LABOR & MATERIAL TOTAL

20.00

253.29

SALES TAX:

9.25%

23.43

TOTAL MATERIAL COST:

276.72

NOTES

| Item | | | | Material | | Field Labor | | |
|--|---------------------|--------|----------------------|----------|----------|---------------|----------|--------------|
| Item # | Category | Size | Item Desc | Qty | Mat Unit | Mat Ext | Fid Unit | Fid Ex |
| Section : Section 001: COR#2 - RFI#76 ADDED 3/4" CD PIPING | | | | | | | | |
| Category : Category 003: COPPER KLM LEAD FREE | | | | | | | | |
| 3030003 | COPPER KLM LEAD ... | 3/4" | M-HARD TUBE | 40 | 1.45 | 58.00 | 0.06 | 2.40 |
| 3060003 | COPPER KLM LEAD ... | 3/4" | 90 ELBOW CxC | 3 | 1.15 | 3.45 | 0.53 | 1.59 |
| 3290001 | COPPER KLM LEAD ... | Unsize | SOLDER LBS. LEADFREE | 1 | 27.00 | 27.00 | Skip | 0.00 |
| 3300001 | COPPER KLM LEAD ... | Unsize | PRESTOLITE--#2 CYL. | 1 | 32.03 | 32.03 | Skip | 0.00 |
| 3590001 | COPPER KLM LEAD ... | Unsize | EVERFLUX--2 OZ. CAN | 1 | 9.75 | 9.75 | Skip | 0.00 |
| Subtotals for Category : Category 003: COPPER KLM LEAD FREE | | | | | | 130.23 | | 3.99 |
| Category : Category 049: HANGER-R.CLAMP-ETC. | | | | | | | | |
| 60 | HANGER-R.CLAMP-... | | 3/8" SAMMY SWG25-380 | 7 | 1.97 | 13.79 | 0.70 | 4.80 |
| 49050008 | HANGER-R.CLAMP-... | 3" | SWIVEL LOOP HGR-GAL. | 7 | 1.76 | 12.32 | 0.60 | 4.20 |
| 49380002 | HANGER-R.CLAMP-... | 3/8" | ALL THREAD ROD | 10 | 1.12 | 11.20 | Skip | 0.00 |
| Subtotals for Category : Category 049: HANGER-R.CLAMP-ETC. | | | | | | 37.31 | | 9.10 |
| Category : Category 085: FIBERGLASS INSUL. | | | | | | | | |
| 85510007 | FIBERGLASS INSUL. | 3" | SADDLE-PROTECT 1" | 7 | 12.25 | 85.75 | 0.13 | 0.90 |
| Subtotals for Category : Category 085: FIBERGLASS INSUL. | | | | | | 85.75 | | 0.90 |
| Subtotals for Section : Section 001: COR#2 - RFI#76 ADDED 3/4" CD PIPING | | | | | | 253.29 | | 14.00 |
| Grand Totals | | | | | | 253.29 | | 14.00 |

Zolnay Insulation, Inc.

918 N. Batavia Orange, CA 92867
CL # 881565 SBE # 1344640
Phone: 714-912-4683 Fax: 714-912-4926

Change Order Proposal

January 4, 2018

City Commercial Plumbing

Attn: Cindy

Subject: Marshall Elementary School - CCP COR#2

We propose to furnish and install Thermal Insulation on the subject project as follows:

Scope:

- Added Pipe Insulation for Condensate Drain
 - Firestopping of Added Pipe Penetrations
- | | |
|------------------------|-----------------|
| Labor: 4 hours @ 81.66 | \$ 326.64 |
| Material: | \$ 135.00 |
| Mark up 15% | <u>\$ 69.24</u> |
| Total | \$ 530.88 |

Exclusions:

Overtime, Man lifts, Victaulic's, Pipe Shields.

This Quote/Bid constitutes the full terms and conditions under which work will be performed. This Quote/Bid supersedes all Requests for Quotations (RFQS), any subcontract terms subsequently forwarded by Contractor or any other project documentation. No additional terms and conditions shall become part of the subcontract absent a formal written subcontract having been entered into and signed by subcontractor subsequent to the date of this Quote/Bid. Customer's acceptance of this Quote/Bid constitutes customer's agreement to the terms set forth herein.

Thank You,

Kevin Wolff
Zolnay Insulation, Inc.



**REQUEST FOR INFORMATION
FOR SUBCONTRACTOR ACTION**

RFI No. : 76

Project: Marshall Elementary - New 6-8 Classroom Bldg.

Date: 11-27-17
Discipline: Electrical

Subject: FC-2- Second floor Electric room

DRAWING & SPECIFICATION REFERENCES

| Drawing Sheet / Specification | Detail / Sub Section | Comments |
|-------------------------------|----------------------|----------|
|-------------------------------|----------------------|----------|

QUESTION

We have discovered that FC-2 in the second floor electric room is impeding on the working space of the electrical panels. Can this unit be moved to the south wall? Please advise

ANSWER

Response:

Yes, however the condensation drain is not allowed to be in electrical room. Must be run through adjacent classroom to service sink

RESPONSE DISTRIBUTION

| Company | Contact | Date Sent |
|--------------------------------|--------------|------------|
| City Commercial Plumbing Inc | Bob Zio | 11/27/2017 |
| Sheldon Mechanical Corp | Dillon Boute | 11/27/2017 |
| JG Tate Fire Protection System | Jim Tate | 11/27/2017 |
| Taft Electric Co | Matt Gobuty | 11/27/2017 |

Please review and advise Bernards, **WITHIN 7 days**, if there are any additional costs or schedule impacts associated with incorporating the RFI response with the Contract Work. (Include a brief description and rough order estimate of the change with this notification. If no response is received within 7 days, Bernards shall trust that there is no impact to your Contract Price or Schedule.

Question Initiated By: Matt Gobuty - Taft Electric Co- Author Number: 13
Submitted By: Matt Gobuty - Taft Electric Co



CHANGE ORDER REQUEST

Project: Marshall Elementary - New 6-8 Classroom Bldg.

COR No. 3 R0
Date: 1/25/2018

DESCRIPTION OF WORK

Per RFI 76 - Add 3/4" Condensate Piping due to relocated fancoil unit in 2nd floor electrical room.

SUMMARY OF COSTS

| Item Description | Company | Amount Requested |
|---|------------------------------|------------------|
| Subcontract Costs | | |
| Per RFI 76 - Add 3/4" Condensate Piping | City Commercial Plumbing Inc | 3,154 |
| | Subtotal: | 3,154 |
| Total Change Order Request Amount: | | 3,154 |

APPROVAL

(Please note that if this Change Order Request is not approved by , additional costs and schedule impacts may result.)

Oxnard School District

Bernards Bros. Inc.

Signature

Printed Name & Title

Date

Signature

Printed Name & Title

Date



CHANGE ORDER REQUEST

COR No. 10 R0

Date: 3/22/2018

Project: Marshall Elementary - New 6-8 Classroom Bldg.

DESCRIPTION OF WORK

SUMMARY OF COSTS

| Item Description | Company | Amount Requested |
|--|------------------------|------------------|
| Subcontract Costs | | |
| Change glass from 1/4" to 1" Per RFI 73 | Santa Barbara Glass Co | 14,923 |
| | Subtotal: | 14,923 |
| Total Change Order Request Amount | | 14,923 |

APPROVAL

(Please note that if this Change Order Request is not approved by 3/29/2018, additional costs and schedule impacts may result.)

Oxnard School District

Bernards Bros. Inc.

Signature

Printed Name & Title

Date

Signature

Printed Name & Title

Date

Signature *McDermott*
CFW *Programs Mgr*



REQUEST FOR INFORMATION

RFI No.: 73-R2

To: Jose Arche
Company: CSDA Design Group
Project: Marshall Elementary - New 6-8 Classroom Bldg.

Date: 01-15-18
Discipline: Architectural

Subject: Glass type required for Energy Compliance

Response Requested By: 01-22-2018

DRAWINGS & SPECIFICATION REFERENCES

| Drawing Sheet / Specification | Detail / Sub Section | Comments |
|-------------------------------|----------------------|----------|
| | | |

QUESTION

Questions:

Per value engineering the store front windows are eliminated, it is not indicated what window system to use in place of the store front system. See attached recommended system to use in place of the store front. Please advise if this is an acceptable system to use.

ANSWER

The Arcadia window is acceptable by CSDA and CFW.
see comments for glass tint.

| | |
|--|---|
| <input type="checkbox"/> NO EXCEPTION TAKEN | CSDA DESIGN GROUP REVIEWED BY: jarche DATE: 1/25/2018 |
| <input type="checkbox"/> REVISE AND RESUBMIT | |
| <input checked="" type="checkbox"/> MAKE CORRECTIONS NOTED | |
| <input type="checkbox"/> REJECTED | |
| <small>REVIEW IS ONLY FOR GENERAL CONFORMANCE WITH DESIGN CONCEPT AND GENERAL COMPLIANCE WITH THE CONTRACT DOCUMENTS. THE CONTRACTOR IS RESPONSIBLE FOR CONFIRMING AND CORRELATING ALL DIMENSIONS AND QUANTITIES, AND FOR COORDINATING WITH WORK OF OTHER TRADES</small> | |

Response Provided By: Jose Arche CSDA 01/25/18
Name Company Date

Question Initiated By: Ed Dickson - Santa Barbara Glass Co - Author Number: 2
Submitted By: Ed Dickson - Santa Barbara Glass Co

MARSHALL
ELEMENTARY SCHOOL
EXAMPLE OF
PROPOSED WINDOW.
Disregard overall window
size

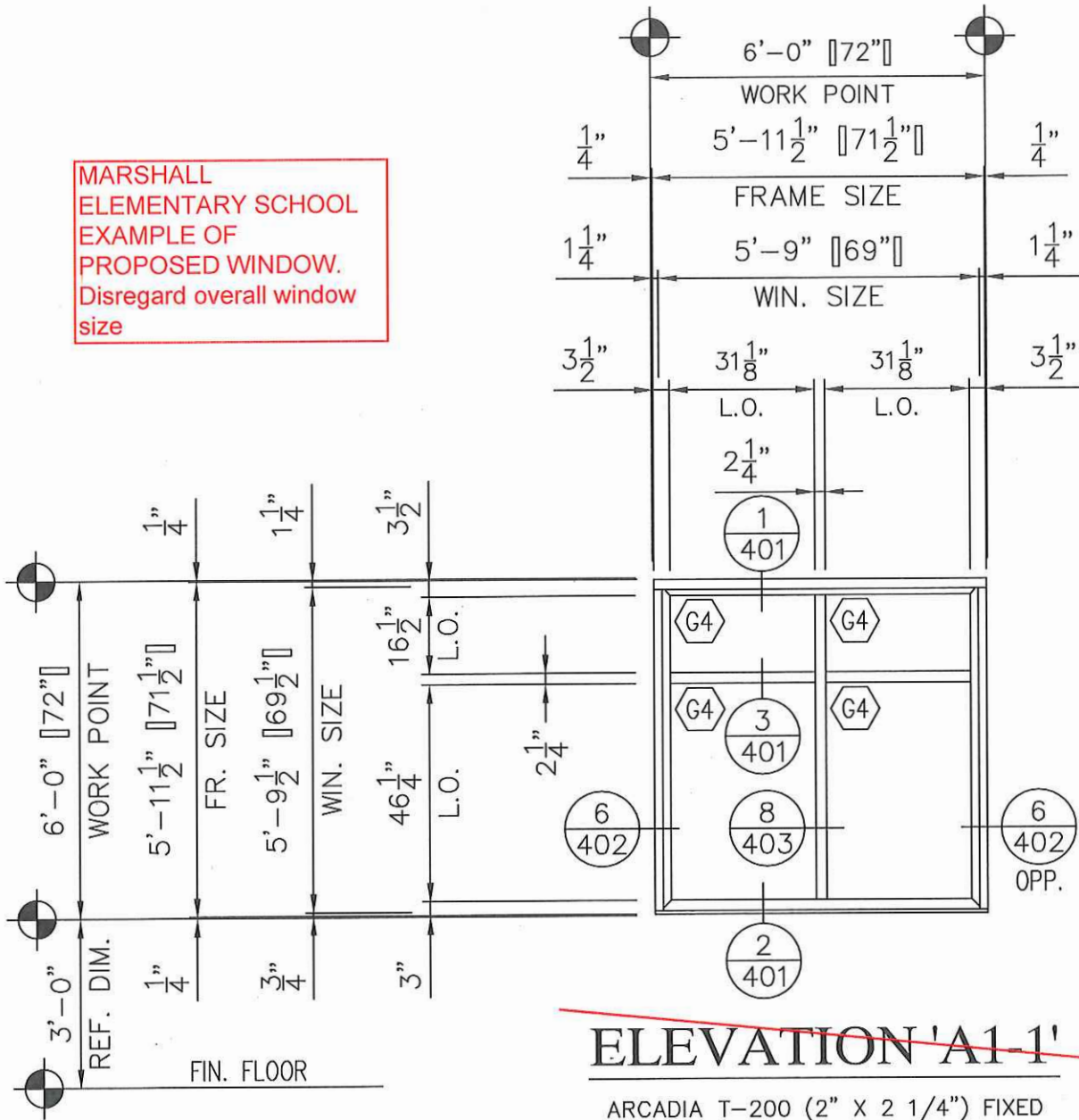

~~ELEVATION 'A1-1'~~

~~ARCADIA T-200 (2" X 2 1/4") FIXED
(12) REQUIRED THUS (4) REQUIRED 48" X 72"~~

~~REF. 1/A1 52.2~~

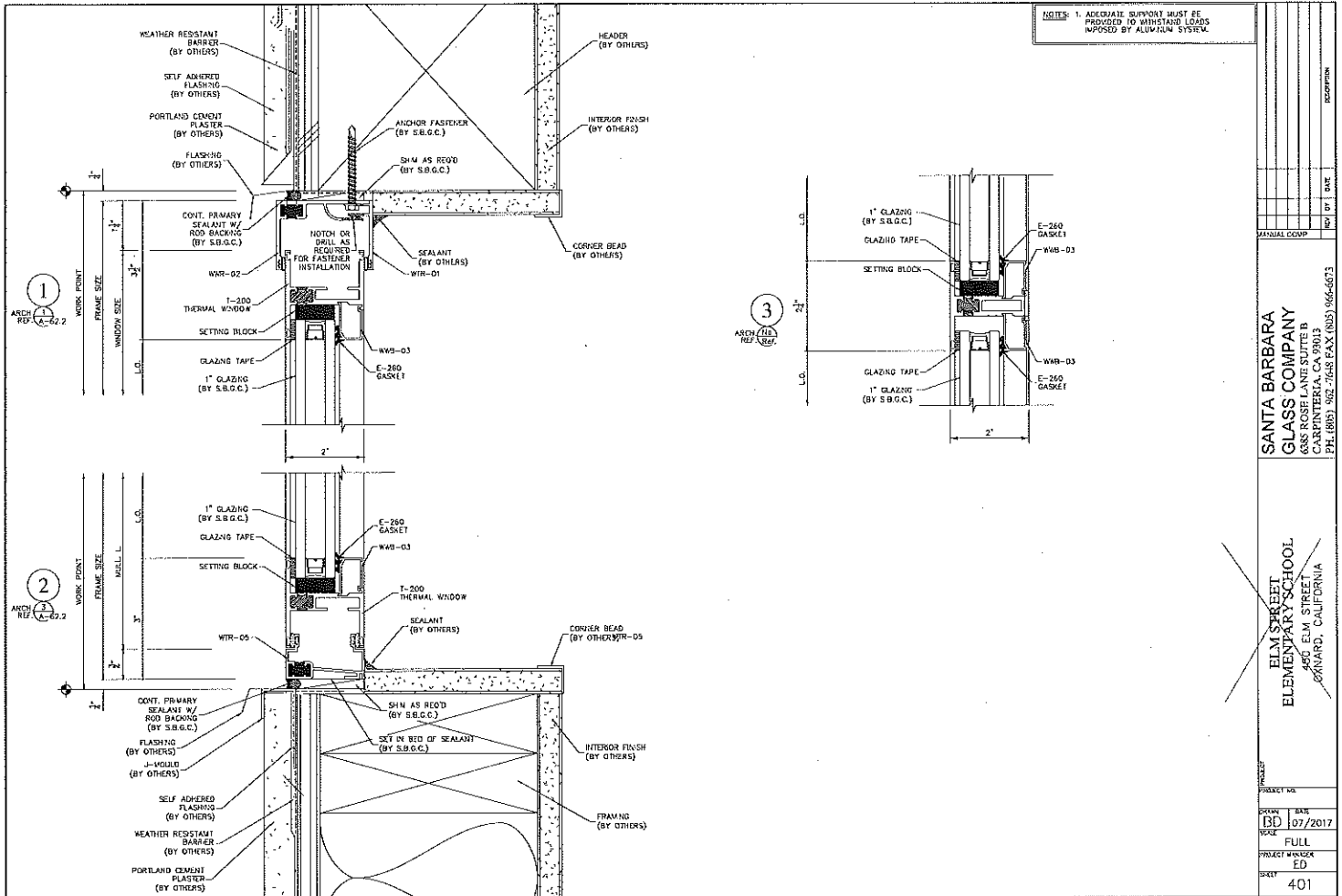

**SANTA BARBARA
GLASS COMPANY**
 6055 CALIFORNIA AVENUE
 CARPINTERIA, CA 93013
 PH: (805) 962-2658 FAX: (805) 966-6073

**ELM STREET
ELEMENTARY SCHOOL**
 4500 ELM STREET
 CORNARD, CALIFORNIA

| | |
|----------------|---------|
| PROJECT NO. | |
| DESIGN | BD |
| DATE | 07/2017 |
| SCALE | FULL |
| PROJECT NUMBER | ED |
| SHEET | 401 |



T200E SERIES WINDOW

T-200E/T-325E SERIES

T-200E/T-325E SERIES THERMAL-IMPACT CASEMENT, AWNING, HOPPER (OPTIONAL) (AVAILABLE AS FIXED, IN SWING OR OUT SWING)



Bridgehampton, NY □ Bates-Masi Architects

MULTIPLE CONFIGURATIONS AVAILABLE

VISIT OUR WEBSITE AT: WWW.ARCADIAINC.COM FOR THE FOLLOWING:

Product Specifications (PDF) • Elevations & Plan Details (PDF & DWG) • Product Warranty Information (PDF) • Maintenance & Cleaning Guidelines (PDF) • Product Installation Manuals (PDF)



Awning

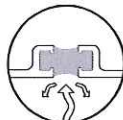

Thermal

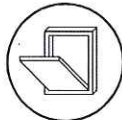

Hopper



Impact



Casement

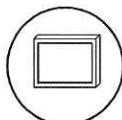

Fixed

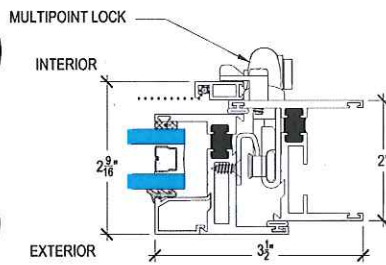

LATCH JAMB

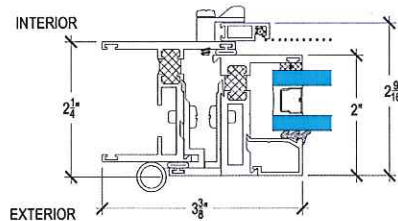

HINGED JAMB

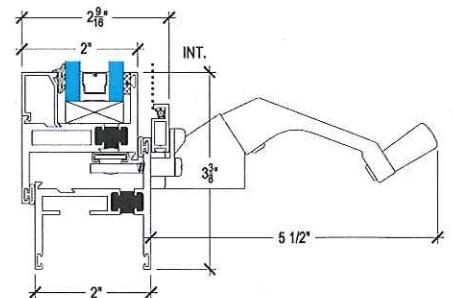

SILL

T-200/T-325 SERIES

FEATURES AND OPTIONS

- T200E is a 2" deep frame system
- T325E is a 3 1/4" deep frame system
- Tested performances as HC rated product
- Low air & water infiltration performance - full thermal frame and panel construction
- Long equal leg, short leg, unequal leg & nail fin framing available - 2" depth framing
- Long equal leg framing available - 3 1/4" depth framing
- Can be configured as an awning (project out), hopper (project in), casement (both project in/out) and fixed picture window
- Casement configuration available standard with color matched custom butt hinges
- Project out awnings & project in hoppers available standard with stainless steel 4-bar hinges
- Fixed screen with clip on mounting brackets are available
- Fixed transoms as well as sidelights available to mate with operable windows
- Roto gear operator with fixed arm available on all casements and awnings - optional
- Casement locks and Cam operating handle locks standard
- Multi point locking hardware for casement window - optional
- Casement locks for awning window mounted on both sides of the frame - optional
- Hopper windows come standard with cam handles
- Can be glazed with interior or exterior stops to accommodate 1" IG Glass
- Stock finishes: dark bronze or satin clear anodized class I or Duracron paint white - standard
- Any Duranar or Valspar finish or other anodized finish - optional
- Can be made to meet impact rated hurricane codes - optional

FEATURES



Southampton, NY, Stelle, Lomont - Rouhani Architects

T-200E/T-325E SERIES

T-200E/T-325E SERIES HARDWARE AND OPTIONS

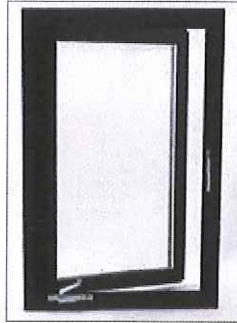

Casement w/ Roto Gear Handle
and Casement Lock



Casement w/ Roto Gear Handle
and Multi Point Lock

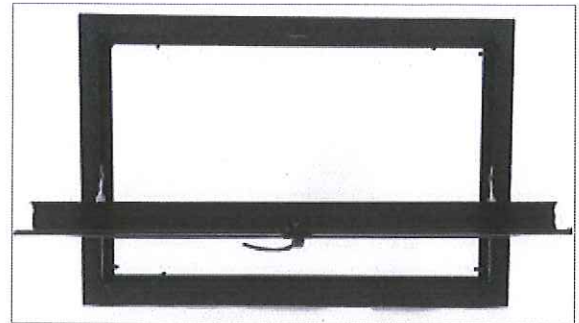

Hopper (Project-in)
In Open Position with Cam Handle

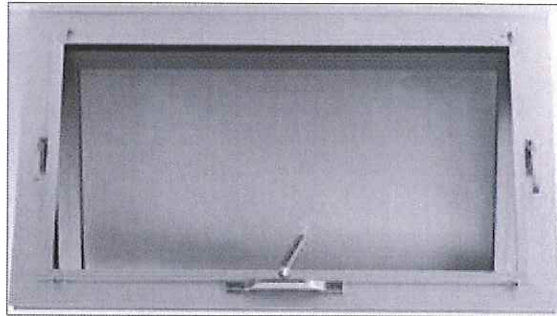

Awning (Project Out) with Pivot Shoe Roto Operator
and Casement Lock

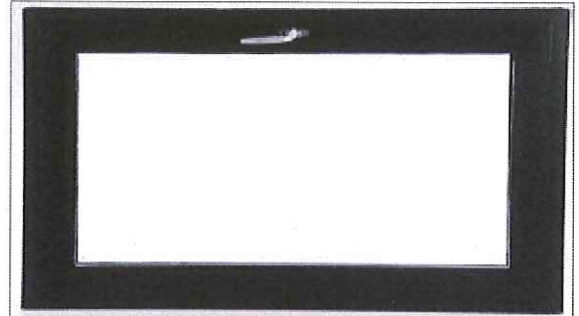

Hopper (Project-in)
In Closed Position with Cam Handle

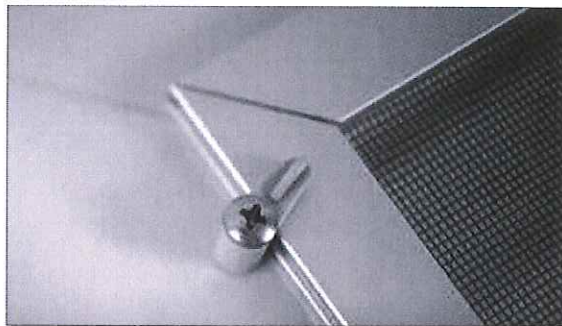

Fixed Window Screen
Mounting Clips

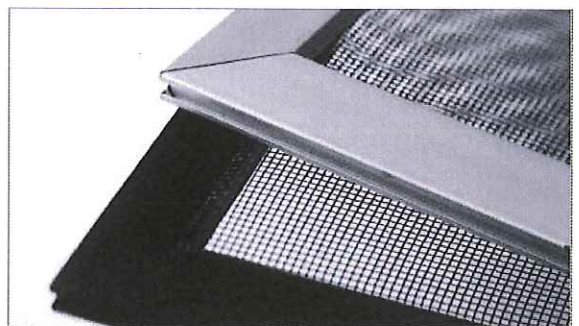

Optional Fixed Window Screen

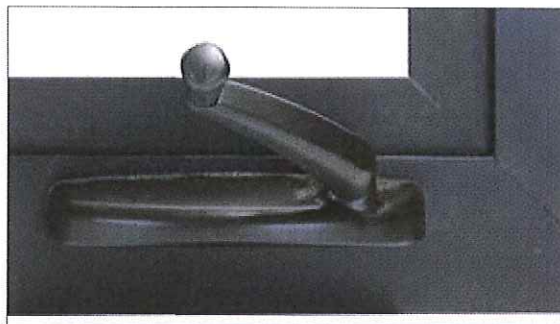

Contour Roto Operator by Truth Hardware- Optional

T-200E/T-325E SERIES HARDWARE AND OPTIONS

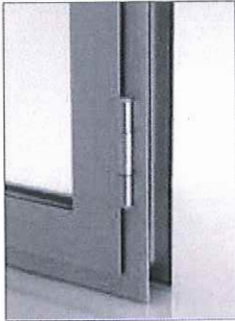

New Style (3) Butt Hinge

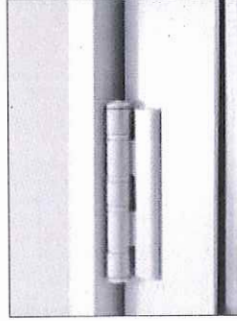

Old Style (5) Butt Hinge



4 Bar Stainless Steel Hinge

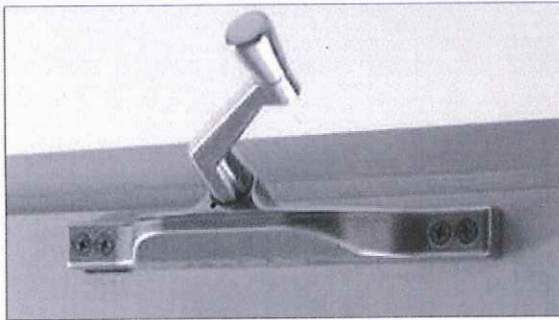

Pivot Shoe Roto Operator (Awning)

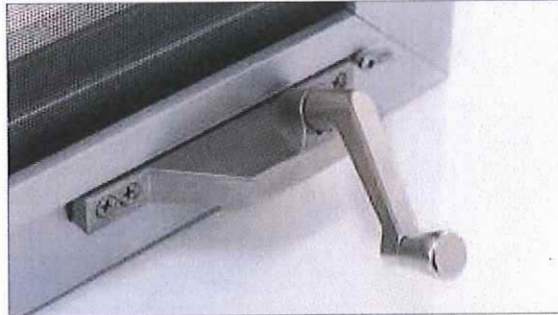

Left or Right Handed Roto Operator (Casement)

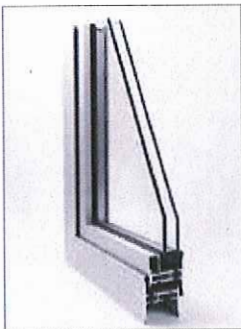

Long Equal Leg Frame

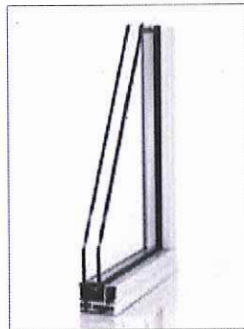

Short Equal Leg Frame

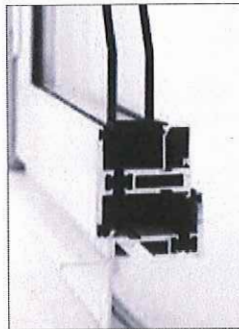

Nail Fin Frame



Multi Point Lock Handle - Optional

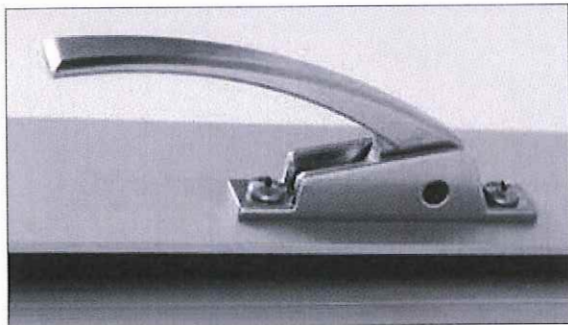

Casement Handle Lock

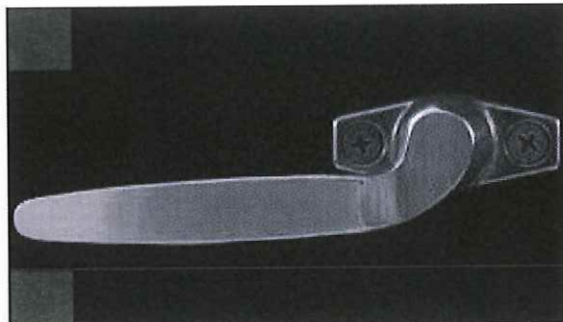

Cam Handle

HARDWARE

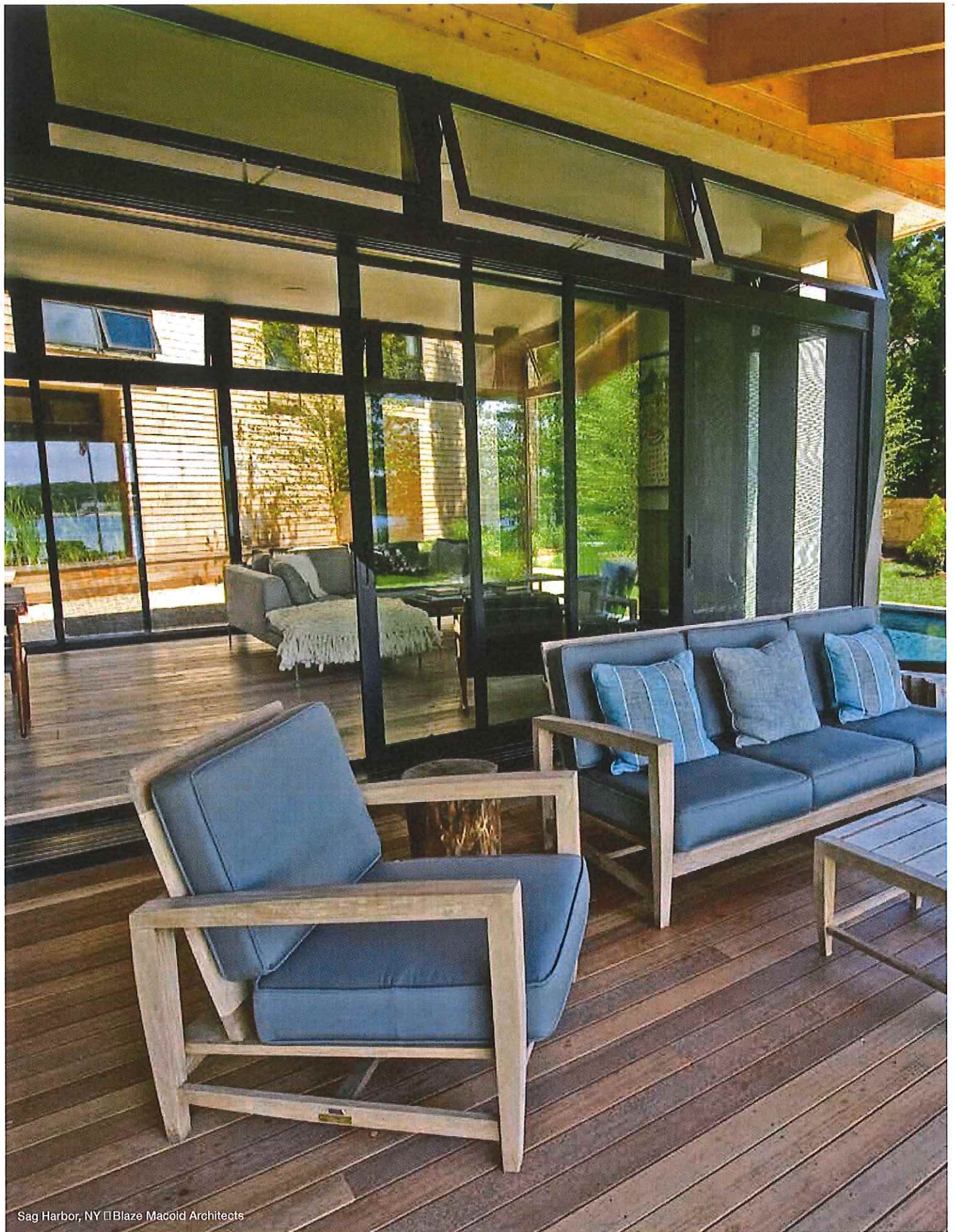

Sag Harbor, NY □ Blaze Macold Architects

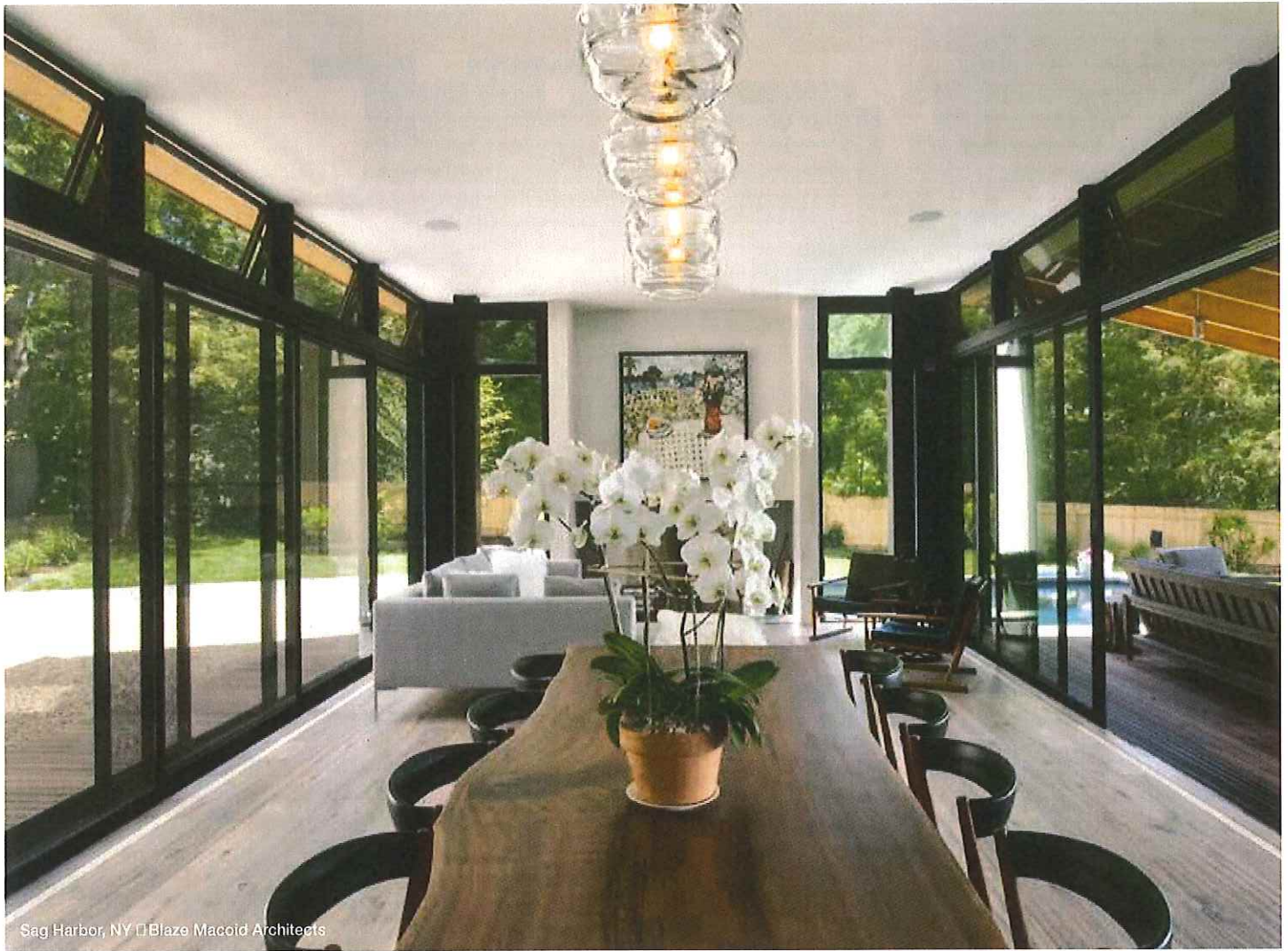

Sag Harbor, NY □Blaze Macoid Architects



Southampton, NY, Stelle, Lomont - Rouhani Architects

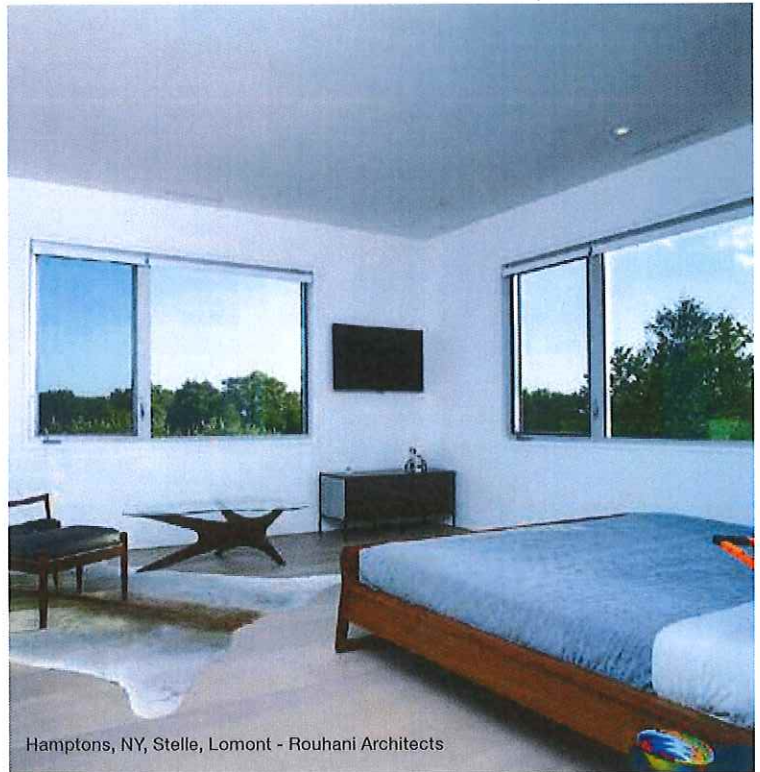

Hamptons, NY, Stelle, Lomont - Rouhani Architects



4 Seasons Resort, Orlando, FL - HKS Architects

Architectural Products - East

60 Bonner Street
Stamford, CT 06902

Ph 203-316-8000

Fx 203-316-8200

east@arcadiainc.com

Architectural Products - West

5190 South Santa Fe Ave.

Vernon, CA 90058

Ph 323-908-5467

Fx 323-908-5547

west@arcadiainc.com

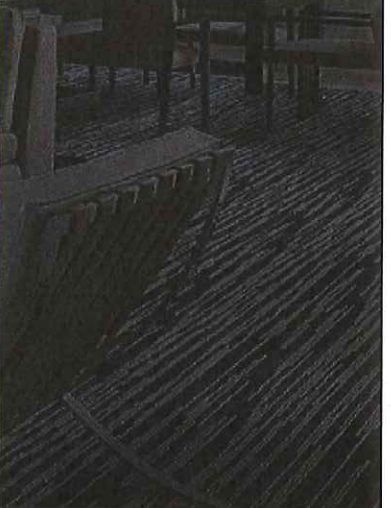

Shelter Island, NY - Stelle Lomont Rouhani Architects

LEEDS CERTIFIED



HURRICANE IMPACT RESISTANT
DOORS & WINDOWS



www.arcadiainc.com

Marshall Elementary
Proposed Glass Type.

SUPERNEUTRAL® SERIES
SNX 62/27, SNX 51/23,
SN 68, SN 54 & SNR 43

CSDA, ja
012518

**MORE NATURAL LIGHT. LESS HEAT GAIN.
GREATER ENERGY SAVINGS.**

SUNGUARD SUPERNEUTRAL 68
Project: Swedish Hospital, Issaquah, WA
Photo: Ben Benschneider



SNX 62/27

- High light transmission
- Neutral reflected & transmitted color
- SunGuard's highest light-to-solar-gain ratio: LSG 2.31
- Solar control: 0.27 SHGC

SNX 51/23

- Superior solar control: 0.23 SHGC
- Light blue outdoor appearance
- Meets the most stringent energy codes in North America

SuperNeutral 68

- Highest light transmission
- Neutral reflected & transmitted color
- Solar control: 0.38 SHGC

SuperNeutral 54

- Less interior glare
- Neutral outdoor appearance
- Best in class CRI (Color Rendering Index)
- Solar control: 0.28 SHGC

SNR 43

- Medium visible light transmission: 43%
- Light silver-blue exterior appearance
- Solar control: 0.23 SHGC

SuperNeutral products are available through independent Guardian Select® Fabricators

To learn more, call us at **1-866-GuardSG (482-7374)** or visit us online **www.SunGuardGlass.com**

BUILD WITH LIGHT®

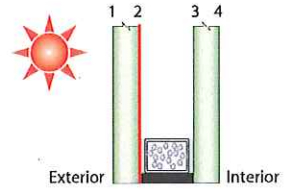

SuperNeutral® Series Insulating Glass Data

| Product | Outboard - Inboard Substrate | Appearance | Transmittance | | | Reflectance | | | U-Value Winter Nighttime | | Relative Heat Gain | Solar Heat Gain Co-efficient | Light to Solar Gain (LSG) |
|----------------------------|------------------------------|--------------|---|----------------|----------------|---------------------|--------------------|--------------------|-------------------------------|-------|--------------------|------------------------------|---------------------------|
| | | | Visible Light % | Ultra-violet % | Solar Energy % | Visible Light Out % | Visible Light In % | Solar Energy Out % | Air | Argon | | | |
| SuperNeutral Series | | | Coating #2 Surface - unless noted (#3) | | | | | | 6 mm/12.7 mm a.s./6 mm | | | | |
| SNX 62/27 | UltraClear - UltraClear | Ultra Clear | 64 | 8 | 24 | 11 | 13 | 51 | 0.29 | 0.24 | 65 | 0.27 | 2.40 |
| | Clear - Clear | Clear | 62 | 6 | 23 | 11 | 12 | 39 | 0.29 | 0.24 | 65 | 0.27 | 2.31 |
| | Green - Clear | Green | 52 | 3 | 18 | 9 | 12 | 10 | 0.29 | 0.24 | 59 | 0.24 | 2.13 |
| | TwilightGreen - Clear | Dark Green | 46 | 2 | 16 | 8 | 11 | 8 | 0.29 | 0.24 | 54 | 0.22 | 2.08 |
| | CrystalGray - Clear | Light Gray | 44 | 3 | 16 | 8 | 11 | 19 | 0.29 | 0.24 | 54 | 0.22 | 1.98 |
| | CrystalBlue - Clear | Blue | 31 | 3 | 12 | 6 | 11 | 19 | 0.29 | 0.24 | 45 | 0.18 | 1.71 |
| SNX 51/23 | UltraClear - UltraClear | Ultra Clear | 40 | 4 | 15 | 7 | 11 | 25 | 0.29 | 0.24 | 51 | 0.21 | 1.91 |
| | Clear - Clear | Light Blue | 53 | 14 | 20 | 14 | 14 | 46 | 0.29 | 0.24 | 57 | 0.23 | 2.28 |
| | Green - Clear | Light Blue | 51 | 11 | 19 | 14 | 14 | 36 | 0.29 | 0.24 | 57 | 0.23 | 2.19 |
| | TwilightGreen - Clear | Blue-Green | 43 | 5 | 15 | 11 | 13 | 10 | 0.29 | 0.24 | 52 | 0.22 | 1.99 |
| | CrystalGray - Clear | Dark Green | 38 | 3 | 13 | 10 | 13 | 8 | 0.29 | 0.24 | 49 | 0.20 | 1.93 |
| | CrystalBlue - Clear | Light Gray | 36 | 6 | 14 | 9 | 13 | 18 | 0.29 | 0.24 | 48 | 0.20 | 1.85 |
| SN 68 | UltraClear - UltraClear | Ultra Clear | 26 | 5 | 10 | 7 | 13 | 17 | 0.29 | 0.24 | 41 | 0.16 | 1.57 |
| | Clear - Clear | Blue | 33 | 7 | 13 | 9 | 13 | 23 | 0.29 | 0.24 | 46 | 0.19 | 1.78 |
| | Green - Clear | Clear | 71 | 40 | 37 | 11 | 13 | 43 | 0.29 | 0.25 | 94 | 0.39 | 1.80 |
| | TwilightGreen - Clear | Dark Green | 68 | 30 | 33 | 11 | 12 | 33 | 0.29 | 0.25 | 90 | 0.38 | 1.80 |
| | CrystalGray - Clear | Light Gray | 57 | 13 | 23 | 9 | 12 | 9 | 0.29 | 0.25 | 72 | 0.30 | 1.92 |
| | CrystalBlue - Clear | Blue | 51 | 9 | 20 | 8 | 11 | 7 | 0.29 | 0.25 | 64 | 0.27 | 1.93 |
| SN 54 | UltraClear - UltraClear | Ultra Clear | 48 | 17 | 23 | 8 | 11 | 16 | 0.29 | 0.25 | 71 | 0.30 | 1.64 |
| | Clear - Clear | Light Gray | 34 | 13 | 18 | 6 | 11 | 16 | 0.29 | 0.25 | 61 | 0.25 | 1.37 |
| | Green - Clear | Gray | 44 | 19 | 23 | 7 | 11 | 21 | 0.29 | 0.25 | 70 | 0.29 | 1.51 |
| | TwilightGreen - Clear | Dark Green | 56 | 22 | 26 | 13 | 19 | 44 | 0.29 | 0.24 | 69 | 0.29 | 1.96 |
| | CrystalGray - Clear | Light Gray | 54 | 16 | 24 | 13 | 18 | 35 | 0.29 | 0.24 | 68 | 0.28 | 1.92 |
| | CrystalBlue - Clear | Blue | 45 | 7 | 17 | 11 | 18 | 10 | 0.29 | 0.24 | 58 | 0.24 | 1.89 |
| SNR 43 | UltraClear - UltraClear | Ultra Clear | 41 | 4 | 15 | 10 | 18 | 8 | 0.29 | 0.24 | 53 | 0.22 | 1.86 |
| | Clear - Clear | Light Silver | 38 | 9 | 17 | 9 | 18 | 17 | 0.29 | 0.24 | 56 | 0.23 | 1.67 |
| | Green - Clear | Green | 27 | 7 | 13 | 7 | 17 | 16 | 0.29 | 0.24 | 48 | 0.19 | 1.40 |
| | TwilightGreen - Clear | Dark Green | 35 | 10 | 16 | 8 | 17 | 22 | 0.29 | 0.24 | 54 | 0.22 | 1.57 |
| | CrystalGray - Clear | Light Silver | 45 | 24 | 21 | 28 | 14 | 54 | 0.29 | 0.24 | 56 | 0.23 | 1.96 |
| | CrystalBlue - Clear | Light Silver | 43 | 17 | 19 | 28 | 14 | 43 | 0.29 | 0.24 | 56 | 0.23 | 1.89 |
| SNX 62/27 (#3) | UltraClear - UltraClear | Ultra Clear | 36 | 8 | 14 | 21 | 14 | 14 | 0.29 | 0.24 | 50 | 0.20 | 1.78 |
| | Clear - Clear | Light Silver | 32 | 5 | 12 | 18 | 14 | 11 | 0.29 | 0.24 | 46 | 0.19 | 1.73 |
| | Green - Clear | Green | 31 | 9 | 13 | 16 | 14 | 21 | 0.29 | 0.24 | 47 | 0.19 | 1.59 |
| | TwilightGreen - Clear | Dark Green | 22 | 8 | 10 | 10 | 13 | 19 | 0.29 | 0.24 | 41 | 0.17 | 1.31 |
| | CrystalGray - Clear | Silver Gray | 28 | 11 | 13 | 14 | 13 | 26 | 0.29 | 0.24 | 46 | 0.19 | 1.50 |
| | CrystalBlue - Clear | Silver Blue | 28 | 11 | 13 | 14 | 13 | 26 | 0.29 | 0.24 | 46 | 0.19 | 1.50 |
| Coating #3 Surface | | | | | | | | | | | | | |
| SNX 62/27 (#3) | Bronze - Clear | Bronze | 37 | 2 | 14 | 7 | 10 | 17 | 0.29 | 0.24 | 64 | 0.26 | 1.41 |
| | Green - Clear | Green | 52 | 3 | 18 | 10 | 10 | 11 | 0.29 | 0.24 | 75 | 0.31 | 1.66 |
| | TwilightGreen - Clear | Dark Green | 46 | 2 | 16 | 9 | 10 | 8 | 0.29 | 0.24 | 67 | 0.28 | 1.66 |
| | CrystalGray - Clear | Light Gray | 44 | 3 | 16 | 8 | 10 | 20 | 0.29 | 0.24 | 72 | 0.30 | 1.48 |
| | CrystalBlue - Clear | Blue | 31 | 3 | 12 | 7 | 10 | 20 | 0.29 | 0.24 | 59 | 0.24 | 1.27 |

Please advise if you want Clear Tint or Green Tint. Existing windows may have green tint.

CSDA, ja
SN 68

- The performance values shown are nominal and subject to variations due to manufacturing tolerances.
- Guardian performance data are calculated for center-of-glass only (no spacer or framing) in accordance with the LBNL Window 7 program.
- Glass may require heat strengthening or tempering to resist potential thermal stresses. SNR 43 must be heat-treated.
- A slight shift in visible light reflectance or transmission may be noticed after heat-treatment.
- Relative Heat Gain, Solar Heat Gain Coefficient and/or LSG may change slightly when using argon gas fill.
- Guardian reserves the right to change product performance characteristics without notice or obligation.

*** NOTES RELATED TO COATINGS DESIGNED FOR #3 SURFACE APPLICATIONS:**

- The SunGuard coatings that can be used on the #3 surface are SN 68, SNX 62/27 and Neutral 78/65. Guardian recommends a tinted or coated outboard lite when these coatings (except Neutral 78/65) are used on the #3 surface. All other SunGuard coatings are not recommended for use on the #3 surface.

TO REQUEST SAMPLES
visit SunGuardGlass.com or call 1-866-GuardSG
482-7374





KEYSTONE CERTIFICATIONS, INC.
 145 LIMEKILN RD, SUITE 100B
 NEW CUMBERLAND, PA 17070
 PHONE: 717-932-8500

Notice of Product Certification Authorization

National Fenestration Rating Council

Issued To:

Manufacturer: Arcadia, Inc.
 Address: 2301 East Vernon Ave
 Vernon CA 90058
 Man'f Code ARA
 Cert Date: 2/26/2002

Certification Number

1542

Product Line Number

ARA - K - 001

Revision Date

6/21/2017

The Following NFRC Product Line Has Been Authorized For Certification:

Model / Series: **T200** Thermal Fixed Exterior Glazed
 Operator Type: FIXD
 Frame Type: AT
 Sash Type: NA
 Exp. Date: 2/25/2019

Ratings Authorized For Certification:

| Rating | Property | Authorized |
|----------|-----------------------------|-------------------------------------|
| NFRC 100 | U-factor | <input checked="" type="checkbox"/> |
| NFRC 200 | Solar Heat Gain Coefficient | <input checked="" type="checkbox"/> |
| NFRC 200 | Visible Light | <input checked="" type="checkbox"/> |
| NFRC 400 | Air Leakage | <input type="checkbox"/> |
| NFRC 500 | Condensation Resistance | <input checked="" type="checkbox"/> |

Fenestration products are not NFRC Certified unless manufactured and labeled in accordance with the current version of NFRC-700, Product Certification Program requirements.

***This is a cover sheet for an NFRC Certification Authorization Report (CAR)
 the corresponding CAR may be downloaded for printing at www.nfrc.org.***

The Manufacturer is authorized to label the options listed in the corresponding CAR

Please notify Keystone of any errors or omissions within 10 days of receipt.

Due diligence was used in authorizing these products for certification. By accepting this report the licensee agrees to hold harmless and indemnify Keystone Certifications, Inc. from all claims or liabilities which may arise based on this certification authorization. Certification authorization is based on NFRC program requirements and simulation and test reports from accredited laboratories.

EXAMPLE OF CLASS PERFORMANCE

NFRC Product Certification Authorization Report

WE PROPOSE SN68
LOW E FOR
MARSHALL
ELEMENTARY. SEE
BELOW



Manufacturer: Arcadia, Inc. Product Series: T200 Thermal Fixed Exterior Glazed Simulation Lab: SFSE Initial Cert. Date: 01/09/2002
 Street: 4620 Andrews Street Product Type: FIXD Sim. Report #: ARA16022-2A-HH Re-Certification Date: 09/03/2015
 City/State/Zip: Las Vegas, NV 89091 Air Leakage: Sim. Report Date: 09/01/2015 Revised Date: 01/26/2017
 Print Date: 06/21/2017 Test Date: 02/25/2015 Expiration Date: 02/25/2019

DOES NOT MEET HD MAX

CPD Number: ARA-K-1 IA: Keystone Certifications, Inc.

| Product ID | Description | AT/NA | U-Factor | SHGC | U-Factor | SHGC | U-Factor | SHGC | U-Factor | SHGC | U-Factor | SHGC | U-Factor | SHGC | U-Factor | SHGC | U-Factor | SHGC | U-Factor |
|-------------|-------------------------------------|-------|----------|-------------------|----------|-------------------------|-------------------------|------|----------|------|----------|------|----------|------|----------|------|----------|------|----------|
| 00008-00001 | CLEAR / AIR / CLEAR_6mm | AT/NA | 2 | 0.500 | A1-S | Fill 1: AIR (100) | N | CL | 0.52 | 0.59 | 0.65 | 36 | | | | | | | |
| 00008-00002 | AZURIA / AIR / CLEAR_6mm | AT/NA | 2 | 0.500 | A1-S | Fill 1: AIR (100) | N | AZ | 0.52 | 0.33 | 0.50 | 36 | | | | | | | |
| 00008-00003 | BRONZE / AIR / CLEAR_6mm | AT/NA | 2 | 0.500 | A1-S | Fill 1: AIR (100) | N | BZ | 0.52 | 0.43 | 0.39 | 36 | | | | | | | |
| 00008-00004 | SOLEXIA / AIR / CLEAR_6mm | AT/NA | 2 | 0.500 | A1-S | Fill 1: AIR (100) | N | OT | 0.52 | 0.42 | 0.57 | 36 | | | | | | | |
| 00008-00005 | SOLAR GREEN / AIR / CLEAR_6mm | AT/NA | 2 | 0.500 | A1-S | Fill 1: AIR (100) | N | OT | 0.52 | 0.35 | 0.50 | 36 | | | | | | | |
| 00009-00001 | CLEAR / ARG / CLEAR_6mm | AT/NA | 2 | 0.500 | A1-S | Fill 1: ARG/AIR (90/10) | N | CL | 0.50 | 0.59 | 0.65 | 36 | | | | | | | |
| 00010-00001 | SB60 / AIR / CLEAR_6mm | AT/NA | 2 | 0.035(2) | 0.500 | A1-S | Fill 1: AIR (100) | N | LE | 0.38 | 0.33 | 0.58 | 36 | | | | | | |
| 00010-00002 | SOLAR GREEN / AIR / SB60_6mm | AT/NA | 2 | 0.035(3) | 0.500 | A1-S | Fill 1: AIR (100) | N | OT | 0.38 | 0.26 | 0.44 | 36 | | | | | | |
| 00010-00003 | SOLAR GRAY / AIR / SB60_6mm | AT/NA | 2 | 0.035(3) | 0.500 | A1-S | Fill 1: AIR (100) | N | OT | 0.38 | 0.25 | 0.29 | 36 | | | | | | |
| 00010-00004 | AZURIA / AIR / SB60_6mm | AT/NA | 2 | 0.035(3) | 0.500 | A1-S | Fill 1: AIR (100) | N | OT | 0.38 | 0.27 | 0.45 | 36 | | | | | | |
| 00010-00005 | BRONZE / AIR / SB60_6mm | AT/NA | 2 | 0.035(3) | 0.500 | A1-S | Fill 1: AIR (100) | N | OT | 0.38 | 0.28 | 0.35 | 36 | | | | | | |
| 00011-00001 | SB60 / ARG / CLEAR_6mm | AT/NA | 2 | 0.035(2) | 0.500 | A1-S | Fill 1: ARG/AIR (90/10) | N | LE | 0.35 | 0.33 | 0.58 | 36 | | | | | | |
| 00012-00001 | SB70_5mm / AIR / CLEAR_6mm | AT/NA | 2 | 0.018(2) | 0.500 | A1-S | Fill 1: AIR (100) | N | LE | 0.38 | 0.24 | 0.52 | 36 | | | | | | |
| 00012-00002 | SOLAR GREEN_6mm / AIR / SB70_5mm | AT/NA | 2 | 0.018(3) | 0.500 | A1-S | Fill 1: AIR (100) | N | LE | 0.38 | 0.24 | 0.40 | 36 | | | | | | |
| 00012-00003 | SB70 Solar Bronze / AIR / CLEAR_6mm | AT/NA | 2 | 0.018(2) | 0.500 | A1-S | Fill 1: AIR (100) | N | LE | 0.38 | 0.19 | 0.33 | 36 | | | | | | |
| 00012-00004 | SB70 / AIR / STARPHIRE_6mm | AT/NA | 2 | 0.018(2) | 0.500 | A1-S | Fill 1: AIR (100) | N | LE | 0.38 | 0.24 | 0.55 | 36 | | | | | | |
| 00012-00005 | AZURIA_6mm / AIR / SB70_5mm | AT/NA | 2 | 0.018(3) | 0.500 | A1-S | Fill 1: AIR (100) | N | LE | 0.38 | 0.25 | 0.40 | 36 | | | | | | |
| 00013-00001 | SB70_5mm / AIR / SG600_6mm | AT/NA | 2 | 0.018(2),0.144(4) | 0.500 | A1-S | Fill 1: AIR (100) | N | LE | 0.32 | 0.22 | 0.47 | 35 | | | | | | |
| 00014-00001 | SB72 / AIR / CLEAR_6mm | AT/NA | 2 | 0.022(2) | 0.500 | A1-S | Fill 1: AIR (100) | N | LE | 0.38 | 0.25 | 0.57 | 36 | | | | | | |
| 00015-00001 | SBz50 / AIR / CLEAR_6mm | AT/NA | 2 | 0.035(2) | 0.500 | A1-S | Fill 1: AIR (100) | N | LE | 0.38 | 0.28 | 0.42 | 36 | | | | | | |
| 00016-00001 | SBR100 / AIR / CLEAR_6mm | AT/NA | 2 | 0.036(2) | 0.500 | A1-S | Fill 1: AIR (100) | N | LE | 0.38 | 0.20 | 0.35 | 36 | | | | | | |
| 00017-00001 | SGSN68 / AIR / CLEAR_6mm | AT/NA | 2 | 0.039(2) | 0.500 | A1-S | Fill 1: AIR (100) | N | LE | 0.38 | 0.32 | 0.56 | 36 | | | | | | |
| 00017-00002 | SGSN54G / AIR / CLEAR_6mm | AT/NA | 2 | 0.034(2) | 0.500 | A1-S | Fill 1: AIR (100) | N | LE | 0.38 | 0.21 | 0.38 | 36 | | | | | | |
| 00018-00001 | SGSN68 / ARG / CLEAR_6mm | AT/NA | 2 | 0.039(2) | 0.500 | A1-S | Fill 1: ARG/AIR (90/10) | N | LE | 0.35 | 0.32 | 0.56 | 36 | | | | | | |

1" INSULATED LOW E SN68 GLASS

green tint glass
Marshall, CSDA ja

Baseline Information

| Test Lab | Test Date | Test Size | Tested U-Value | Standard U-Value | Test Report Number |
|----------|------------|-------------------|----------------|------------------|--------------------|
| TATF | 02/25/2015 | 1200 mm x 1502 mm | 0.445 | 0.433 | E5726.01-301-46 |

Comments: 90% Argon dual probe sensed. 6/23/16: Added Options 21-28. 1/19/17 added options 29-31. 3/7/17: Added Option 32.
6/20/17: Added options 33-39
6/20/17: Added option 40

I hereby certify that all requirements for NFRC Certification Authorization have been met and that the above information is true and correct, to the best of my knowledge.

Authorized IA Signature:  Digitally signed by Jon Hill
Date: 2017.06.21 09:38:36
-04'00'



T200 Series

2" Heavy Commercial (Thermal)
Fixed (F-Aw55 Grade) - Casement (C-Aw80 Grade)
Awning And Hopper (Ap-Aw80 Grade)

1995 CSI SECTION 08520 Aluminum Windows
2004 CSI SECTION 08 51 13 Aluminum Windows

Part 1 - General

1.01 Summary

- A. Section includes:
1. Aluminum Windows
a. Arcadia Inc., T200 Series (thermal) Heavy Commercial Fixed, Casement, Awning and Hopper Windows, 2-inch depth.
B. Related Sections:

1.02 References

- A. American Architectural Manufacturers Association (AAMA)
B. American Society for Testing and Materials (ASTM)
C. Aluminum Association (AA)
D. National Wood Window & Door Association (NWWDA)
E. California Association of Window Manufacturers (CAWM)

1.03 System Description

- A. General: In addition to requirements shown or specified, comply with:
1. Applicable provisions of AAMA Windows and Sliding Glass Doors Manual for design, materials, fabrication and installation of component parts.
B. Design Requirements: Arcadia T200 Series (thermal) Heavy Commercial Fixed, Casement, Awning and Hopper Windows 2-inch depth. Hinged compression sealed aluminum windows. Suitable for outside or inside glazing.
C. Performance Requirements: Each assembly shall be tested by a recognized testing laboratory or agency in accordance with specified test methods.
1. Conformance to F-AW55, C-AW80, AP-AW80 specifications in AAMA/NWWDA 101/I.S. 2/A440-8.
a. Air Infiltration: Accordance with ASTM E 283 at a static air pressure difference of 6.24 psf. Air infiltration shall not exceed .30 cfm per square foot.
b. Water Resistance: Accordance with ASTM E 331/ASTM E 547 at a static air pressure difference of 12 psf. No water leakage.
c. Uniform Load Structural: Aluminum window systems comply with AAMA/WDMA/CSA 101/I.S.2/A440-08, Voluntary specifications for aluminum windows. Guidelines for specified AW rated product.
d. Component testing: Accordance with procedures described in AAMA/NWWDA 101/I.S. 2/A440-08.
e. Forced Entry Resistance: All windows shall conform to CAWM 301-90.
f. Condensation Resistance Test: (CRF) when tested in accordance with AAMA 1503.1-88, the condensation resistance factor shall not be less than 51.
g. Thermal Transmittance Test: Accordance with AAMA 1503.1-88, (U-Value) not more than .59 BTU/hr/sq/F.
h. Thermal Movements: Allow thermal movement resulting from the following maximum change (range) in ambient temperature.
(a) 120 deg F (67 deg C), ambient; 180 deg F (100 deg C), material surfaces.

1.04 Quality Assurance

- A. Single Source Responsibility:
1. Obtain entrances, storefronts, ribbon walls, window walls, curtain walls, window systems, and finish through one source from a single manufacturer.
B. Provide test reports from AAMA accredited laboratories certifying the performances as specified in 1.03.

1.05 Warranty

- A. Warranted against failure and/or deterioration of metals due to manufacturing process for a period of two (2) years.

Part 2 - Products

2.01 Manufacturers

- A. Acceptable Manufacturers:
1. Arcadia, Inc., 2301 E Vernon, Vernon, CA. Telephone 323/269-7300, Fax 323/269-7390.

B. Acceptable Products:

- 1. Arcadia Inc., T200 Series (thermal)

2.02 Materials

- A. Extruded aluminum profiles 6063-T6 alloy and temper (ASTM B221 G.S. 10A-T6).
B. All framing members .125 minimum wall thickness.
C. At Casement, Awning, and Hopper windows provide heavy-duty four bar hinges shall be stainless steel only, with asymmetric end caps, and adjustable limit stops. Lock and latches cast white bronze, US-25D finish.
D. Weatherstrip EPDM bulb type conforming to ASTM D2000 AA515 and shall be keyed into extruded grooves.
E. Back glazing two-sided adhesive, 15 lbs./ft.3 density, polyethylene tape. Glazing wedges shall be EPDM or Santoprene.
F. At operable windows provide screens made of extruded aluminum frame and screened with either 18 x 14 aluminum or fiber mesh.
G. Thermal barrier material poured-in-place two part polyurethane.

2.03 Finish

- 2. An Architectural Class II or I color anodic coating conforming with AA-M12C22A34/AA-M12C22A44.
a. Anodized finish color shall be Colornodic _____. (AB1 Light Champagne, AB2 Champagne, AB3 Light Bronze, AB4 Medium Bronze, AB5 Standard Medium Bronze, AB6 Dark Bronze, AB7 Standard Dark Bronze, AB8 Black.)
(or) 1. An Architectural Class II or I anodic coating conforming with AA-M12C22A31/AA-M12C22A41.
a. Anodize finish color shall be Colornodic _____ (#11 Clear)
(or) 1. Fluorocarbon Coating: AAMA 2605.2.
a. Resin: 70% PVDF Kynar 500/Hylar 5000.
b. Substrate: cleaned and pretreated with chromium phosphate.
c. Primer: Manufacturer's standard resin base compatible coating. Dry film thickness.
(a) Extrusion: Minimum 0.20 mil.
d. Color Coat: 70% PVDF, dry film thickness.
(a) Extrusion: 0.20 mil.
e. Color: As selected by Architect.
f. Acceptable Coatings Manufacturers:
(a) PPG Industries, Inc.
(b) Valspar Corporation
(c) BASF

2.04 Fabrication

- A. Frame components mitered, reinforced extruded corner key, hydraulically crimped, and "cold welded."
B. All ventilator extensions tubular, each corner mitered, reinforced extruded corner key, hydraulically crimped, and "cold welded."
C. All corners weather sealed with an elastomeric sealant.

Part 3 - Execution

3.01 Examinations

- A. Examine conditions and verify substrate conditions are acceptable for product installation.

3.02 Installation

- A. Install in accordance with approved shop drawings and manufacturers installation instructions.

3.03 Field Quality Control

- A. Contractor's responsibility to make all necessary final adjustments to attain normal operation of each window and its mechanical hardware.

END OF SECTION



CHANGE ORDER REQUEST

COR No. 12 R0

Date: 3/22/2018

Project: Marshall Elementary - New 6-8 Classroom Bldg.

DESCRIPTION OF WORK

Resurveying at playground

SUMMARY OF COSTS

| Item Description | Company | Amount Requested |
|--|---------------------------|------------------|
| Subcontract Costs | | |
| Resurveying at playground | Benner and Carpenter, Inc | 480 |
| Resurveying at playground | Benner and Carpenter, Inc | 2,458 |
| Grade change | Damar Construction Inc | 2,169 |
| | Subtotal: | 5,107 |
| Total Change Order Request Amount | | 5,107 |

APPROVAL

(Please note that if this Change Order Request is not approved by , additional costs and schedule impacts may result)

Oxnard School District

Bernards Bros. Inc.

Signature

Signature

Printed Name & Title

Printed Name & Title

Date

Date

Jennifer McCracken
CFW Program Mgr

Benner and Carpenter, Inc.
Civil Engineers • Land Surveyors
506 E. Main Street
Santa Paula, California 93060

Memo

(805) 525-3396

(805) 656-1989 fax

To: Bernards
Attn: Rebecca Miller

From: Stephanie Spencer

Subject: Marshall Elem. School, Oxnard

Date: 3/6/18

Comments:

Request for Change Order:

Surveying Services on 2/26/18:

Re-stake playground -

2.0 hrs. Two Man Field Crew @ \$240/hr. = \$480.00

Total requested change order amount = \$480.00

Request # BC02



BENNER and CARPENTER, INC.

CIVIL ENGINEERS • LAND SURVEYORS

306 EAST MAIN STREET - SANTA PAULA, CALIFORNIA 93060 - (805) 525-3396

SURVEY REQUEST

Client BERNARDS

Project MARSHALL JARDON Job No. 17-744

Ordered By WILL Date _____

Order Received By _____ Date 2/26/18

The following survey work was requested: RESURFACE PLAY GROUND

- Fees to be charged per contract
- Work requested is extra and is to be charged at per diem rate
- Work requested to be charged at per diem rate.

Work approved by: X [Signature]
(Superintendent or Owner)

Party Chief: [Signature] Start 2-26-2018 Completed 2-26-2018

Remarks: _____

Survey time 2 Hrs. Materials _____

Benner and Carpenter, Inc.
Civil Engineers • Land Surveyors
506 E. Main Street
Santa Paula, California 93060

Memo

(805) 525-3396

(805) 656-1989 fax

To: Bernards
Attn: Rebecca Miller

From: Stephanie Spencer

Subject: Marshall Elem. School, Oxnard

Date: 2/14/18

Comments:

Request for Change Order:

Surveying Services on 2/2/18 & 2/9/18:

Topographic survey & plot shots, prepare grading plan, and re-calc and re-stake rubber mat play area -

| | |
|---|---------------|
| 5.0 hrs. Two Man Field Crew @ \$240/hr. = | \$1,200.00 |
| 2.75 hrs. Designer-Computer @ \$130/hr. = | 357.50 |
| 5.0 hrs. Principal Engineer @ \$180/hr. = | <u>900.00</u> |

Total requested change order amount = \$2,457.50

Request # BC 01



BENNER and CARPENTER, INC.

CIVIL ENGINEERS • LAND SURVEYORS

506 EAST MAIN STREET - SANTA PAULA, CALIFORNIA 93060 - (805) 525-3396

Notes:

SURVEY REQUEST

Client BERNARDS

Project MARSHALL SCHOOL Job No. 17-144

Ordered By _____ Date 2-2-18

Order Received By _____ Date _____

The following survey work was requested: TOPG

Fees to be charged per contract

Work requested is extra and is to be charged at per diem rate

Work requested to be charged at per diem rate

Work approved by: Willie Vandy 02-05-18
(Superintendent or Owner)

Party Chief: R. THOMAS, K. MARTIN Start 2-2 Completed 2-2

Remarks: _____

Survey time 2 Hrs. Materials _____



BENNER and CARPENTER, INC.

CIVIL ENGINEERS • LAND SURVEYORS

506 EAST MAIN STREET - SANTA PAULA, CALIFORNIA 93060 - (805) 525-3396

SURVEY REQUEST

Client BERNARDS
Project MARSHALL SCHOOL Job No. 17-144
Ordered By HILL Date _____
Order Received By _____ Date 2/8/18
The following survey work was requested: REMAKE PLAY MAT AREA

- Fees to be charged per contract
 Work requested is extra and is to be charged at per diem rate
 Work requested to be charged at per diem rate

Work approved by: X [Signature] 02-09-18
(Superintendent or Owner)

Party Chief: R. THOMAS, A. VALIJAN Start 2-9 Completed 2-9

Remarks: _____

Survey time 3 Hrs. Materials _____



Damar Construction, Inc.

4773 Ortega Street
Suite B
Ventura CA 93003
(805) 654-8438

License: 722632

Request for Change Order

RFCO#03

C.O.#: TBD

Order Date: 02/20/2018

To: Bernard Brother's, Inc.
555 First Street
San Fernando CA 91340

Project: 17035
Marshall Elementary Classroom
2900 Thurgood Marshall Drive
Oxnard CA 93036

This is a request for review and approval. Once approved, the Change Order will reflect on the next billing application.

The contractor agrees to perform and the owner agrees to pay for the following changes to this contract

Plans Attached

Ordered By:

Customer Order:

Specifications Attached

| Description of Work | Amount |
|---------------------------|----------|
| Grade Changes @ Play Area | 2,169.00 |

Notes

Negative changes will lower the overall contract price requiring no additional payment by owner.

Requested Amount of Change

2,169.00

| | |
|--|------------|
| The original Contract Sum was | 131,609.00 |
| Net change by previous Change Orders | 50,315.00 |
| The Contract Sum prior to this Change Order | 181,924.00 |
| The Contract Sum will be changed by this Change Order | 2,169.00 |
| The new Contract Sum including this Change Order will be | 184,093.00 |

Approved _____ Date _____

Date _____

Contractor _____ Owner _____



4773 Ortega Street
 Ventura, CA 93003
 Phone: (805) 654-8438
 Fax: (805) 654-8553

JOB WORK ORDER

JFCO-03

W.O. No. 10248

Bernard Brothers
 Bill To

2/19/18
 Date

Address

Telephone No.

City, State & Zip

Contact

Marshall School
 Project & Location

Project No.

Work Description:

Start to cut for V ditch strip grass land to front
 with 210 Dig with 420 and grade checker

210 operated 1 hr Darrell
 420 operated 1 hr Scott
 Grade Checker 1 hr Josh

* Lay down geo grid piece 65' feet ~~by~~ 12' feet

| Quantity | | Unit Price | Extended |
|----------|-------------------|------------|---------------|
| 2 | Operator | 86.90 | 173.80 |
| 2 | P/u | 20.29 | 40.58 |
| 1 | Step 1 Apprentice | 62.47 | 62.47 |
| 1 | 210 SKIPLADER | 34.17 | 34.17 |
| 1 | 420 BACKHOE | 41.15 | 41.15 |
| 0.40 | Roll TX7 Geogrid | 937.53 | 375.01 |
| | | | 727.18 |
| | | 15% | 109.08 |
| | | | 836.26 |

The above work is authorized and approved for payment by:

[Signature]

Signature and Title

02-19-18

Date

Note: Our terms are net 30 days. Past due accounts subject to interest charges at legal rates. No retentions are allowed without prior approval. Equipment moves will be added by the office. Overtime is per Operating Engineers agreement.



TRIUMPH GEO-SYNTHETICS, INC.

1235 N. GROVE ST. ANAHEIM, CA 92806

PHONE (888) 775-7545 FAX (714) 237-1649

Certified DBE/WBE/SBE/UDBE Sales@TriumphGeo.com

QUOTATION

Quote Number

82835

PLEASE REFERENCE THIS QUOTE #

**** FINAL MATERIAL QUANTITY IS SOLE RESPONSIBILITY OF CONTRACTOR ****

To: **JASON FISCALINI**

Damar Construction
4773 Ortega St.
Ventura, CA 93003
805 654 8438

Bid/Project Date: 02/19/2018

TX-7 Project

Tensar TX-7

Ventura, CA

Fax: 805-654-8553

Email: jason@damar.construction

FOR QUESTIONS ABOUT THIS QUOTE, PLEASE CALL FORREST PHARACH AT (888) 775-7545 OR EMAIL FORREST@TRIUMPHGEO.COM

| Bid Item # | Est.Qty | Units | Part.# | Description | Price | Units | |
|------------|---------|-------|--------------|--|-----------|-------|-----------|
| | 2148.4 | sf | 99-TX7 (450) | Tensar High Strength Triaxial Geogrid 13.1'x164', 239.1 sy/roll | \$0.405 | sf | \$870.102 |
| | | | | | \$870.102 | Roll | 67.43 TAX |

937.53

7

7

7

7

7

7

7

WBE / DBE / SBE SUPPLY 60% credit or per project specs. Contractor to confirm product qualification at bid date. Price Quote Firm 30 Days from Bid. Subject to escalation thereafter. Orders less than bid quantity subject to Unit Price Increase. Quotes are for standard roll sizes unless noted otherwise. Quantities based upon customer provided data or engineers estimate. Determination of all quantities required for completion of project is sole responsibility of contractor.

RETURNS: Returns within 30 days of sale subject to a 25% restocking charge plus freight in and out. Must be in original packing & in good condition. No returns accepted on nonstandard or custom fabrication. Materials manufactured for a specific project are NOT returnable. All returns must have a Return Authorization Number.

FUEL SURCHARGES may apply due to volatile market conditions differing from time of quote.

TERMS: Accounts due 30 days of Invoice Date. Finance Charge 1.5% per month Past 30 Days. Customer agrees to pay all legal, interest and collection fees incurred by company in collection of payment. WILL CALL ITEMS not available at all locations.

Sales Tax NOT INCLUDED in prices.

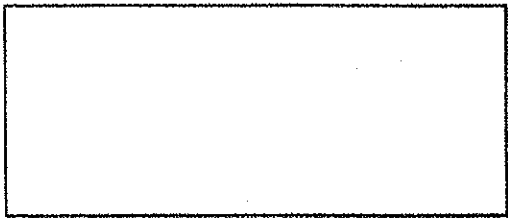



4773 Ortega Street
 Ventura, CA 93003
 Phone: (805) 654-8438
 Fax: (805) 654-8553

JOB WORK ORDER

W.O. No. 10249

Bill To Bernard Brothers

Date 2/20/18

Address _____

Telephone No. _____

City, State & Zip _____

Contact _____

Project & Location Marshall School

Project No. _____

Work Description:

Cut for flow line back side of play ground
 haul dirt and grass to front of job

210 operated 4hr Bailey
 420 operated 4hr Scott

DO scrape maintenance
 sand bags 1hr Scott
 210 operated 2hr's Bailey
 water truck 1hr Scott

| Quantity | | Unit Price | Extended |
|----------|----------------|------------|-------------------|
| 8 | OPERATOR | 86.90 | 695.20 |
| 8 | PLU | 20.29 | 162.32 |
| 4 | 210 SKIDLOADER | 34.17 | 136.68 |
| 4 | 420 BACKHOE | 41.15 | 164.60 |
| | | | 1,158.80 |
| | | 15% | 173.82 |
| | | | <u>\$1,332.62</u> |

The above work is authorized and approved for payment by:

Willie King

Signature and Title

02-20-18

Date

Note: Our terms are net 30 days. Past due accounts subject to interest charges at legal rates. No retentions are allowed without prior approval. Equipment moves will be added by the office. Overtime is per Operating Engineers agreement.



**REQUEST FOR INFORMATION
FOR SUBCONTRACTOR ACTION**

RFI No. : 102

Project: Marshall Elementary - New 6-8 Classroom Bldg.

Date: 01-23-18
Discipline: Athletic Fields

Subject: Play ground equipment Location

DRAWING & SPECIFICATION REFERENCES

| Drawing Sheet / Specification | Detail / Sub Section | Comments |
|-------------------------------|----------------------|----------|
| C-203 | | |

QUESTION

In the current playground equipment location, there are irrigation controller valve and gas line connections. We suggest to move the location of the equipment to 10 feet south of existing location. Please conform

ANSWER

Response:

Suggestion on moving the play structural by 10' is acceptable to avoid utilities

Responded By Jose Arche, CSDA on 01/19/18

RESPONSE DISTRIBUTION

| Company | Contact | Date Sent |
|---------|---------|-----------|
|---------|---------|-----------|

Please review and advise Bernards, **WITHIN 7 days**, if there are any additional costs or schedule impacts associated with incorporating the RFI response with the Contract Work. (Include a brief description and rough order estimate of the change with this notification. If no response is received within 7 days, Bernards shall trust that there is no impact to your Contract Price or Schedule.

Question Initiated By: William Van Zee - Bernards
Submitted By: William Van Zee - Bernards



REQUEST FOR INFORMATION

RFI No.: 102

To: Jose Arche
Company: CSDA Design Group
Project: Marshall Elementary - New 6-8 Classroom Bldg.

Date: 01-04-18
Discipline: Athletic Fields

Subject: Play ground equipment Location

Response Requested By: 01-11-2018

DRAWINGS & SPECIFICATION REFERENCES

| Drawing Sheet / Specification | Detail / Sub Section | Comments |
|-------------------------------|----------------------|----------|
| C-203 | | |

QUESTION

In the current playground equipment location, there are irrigation controller valve and gas line connections. We suggest to move the location of the equipment to 10 feet south of existing location. Please conform

ANSWER

Suggestion on moving the play structural by 10' is acceptable to avoid utilities.

Response Provided By: Jose Arche CSDA 01-19-18
Name Company Date

Question Initiated By: William Van Zee - Bernards
Submitted By: William Van Zee - Bernards



CHANGE ORDER REQUEST

COR No. 13 R0

Date: 3/22/2018

Project: Marshall Elementary - New 6-8 Classroom Bldg.

DESCRIPTION OF WORK

CCD 12 - remove & replace rebar @ 34&35

SUMMARY OF COSTS

| Item Description | Company | Amount Requested |
|---|----------------|------------------|
| Subcontract Costs | | |
| | Vista Steel Co | 2,606 |
| | Subtotal: | 2,606 |
| Total Change Order Request Amount: | | 2,606 |

APPROVAL

(Please note that if this Change Order Request is not approved by , additional costs and schedule impacts may result)

Oxnard School District

Bernards Bros. Inc.

Signature

Printed Name & Title

Date

Signature

Printed Name & Title

Date

Jennifer McIsaac
CFW Program Mgr

VISTA Steel Company

January 2, 2018

BERNARDS BUILDERS MGT
555 FIRST STREET
SAN FERNANDO, CA 91340

Project: MARSHALL NEW CLASSROOM

Re: VT1804
CC#3

Gentlemen,

Following is the description and breakdown for the above referenced additional charge:

| CC# 3 | Remove & replaced rebar in beam's #34 -#35 requested by Bernards CCD 012 Step Ftgs | QTY | UOM | | |
|--------------|---|-------|------|-----------|--------------|
| | Fabricated material | 1,111 | LBS | \$ | 811.03 |
| | Detailing | 0.00 | HRS | \$ | - |
| | Cartage | 0.00 | HRS | \$ | - |
| | Installation | 18 | HRS | \$ | 1,454.76 |
| | Subsistence | 0 | DAYS | \$ | - |
| | Accessories | | LS | \$ | - |
| | SUBTOTAL | | | \$ | 2,265.79 |
| | Overhead 15% | | | \$ | 339.87 |
| | SUBTOTAL | | | \$ | 2,605.66 |
| | Profit | | | \$ | - |
| TOTAL | | | | \$ | 2,606 |

This change will appear and become due with your next invoice. If this change is the responsibility of the owner we request that you process it immediately.

Respectfully submitted,

VISTA Steel Company

Iqbal Toor

Iqbal Toor
Contract Administrator

APPLICATION FOR APPROVAL OF CONSTRUCTION CHANGE DOCUMENT - CCD CATEGORY A/B



This application is for construction changes, as defined in IR A-6, to approved contract documents. This form shall be completed by the Design Professional in General Responsible Charge of the project, in accordance with California Code of Regulations, Title 24, Part 1, Section 4-338 (c) and in compliance with DSA IR A-6.

| | |
|--|-------------------------|
| School District/Owner: Oxnard School District | DSA File #: 56 - 22 |
| Project Name/School: Marshall Elementary School New Classroom Building | DSA App. #: 03 - 116806 |

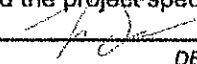
| APPLICANT | | |
|---|------------------------------|--|
| CCD Cat. <input checked="" type="checkbox"/> A / <input type="checkbox"/> B, #012 | Date Submitted: 12/18/17 | Attached Pages?: <input type="checkbox"/> No <input checked="" type="checkbox"/> Yes (4 pages) |
| For CCD Cat. B, this is a <input type="checkbox"/> voluntary submittal, <input type="checkbox"/> DSA required submittal (attach DSA notification requiring submission). | | |
| Firm Name: CSDA Design Group | Contact Name: Michael Schoen | |
| Email: mschoen@csdadesigngroup.com | Phone Number: (310) 301-4772 | |
| Address: 889 N Douglas St, Suite 100 | | |
| City: El Segundo | State: CA | Zip: 90245 |
| <input type="checkbox"/> A DSA 301-N, DSA 301-P, or 90-Day Letter has been issued for this project. | | |
| <input checked="" type="checkbox"/> For project currently under construction. | | |
| <input type="checkbox"/> To obtain DSA approval of existing uncertified building(s). | | |

| DESIGN PROFESSIONAL IN GENERAL RESPONSIBLE CHARGE | |
|---|-----------------------|
| Name of Design Professional in General Responsible Charge: Michael Schoen | |
| Professional License #: C-35165 | Discipline: Architect |
| Design Professional in General Responsible Charge Statement: The attached Construction Change Documents have been examined by me for design intent and appear to meet the appropriate requirements of Title 24, California Code of Regulations and the project specifications. They are acceptable for incorporation into the construction of the project. | |
| Signature:  DESIGN PROFESSIONAL IN GENERAL RESPONSIBLE CHARGE | |

| |
|--|
| CHECK THIS BOX: <input checked="" type="checkbox"/> To confirm that all CCD drawings and, when applicable, first sheet or index of calculations and specifications have been stamped and signed by the Responsible Design Professional listed on DSA 1 for this this project. |
| Brief description of construction change (attach additional sheets if needed): Due to excess reinforcement at the footing denoted in SSK-01, Stepped Footing detail, 16/S-400, is to be modified such that the lap splice length is reduced per attached SSK-02. |
| List of DSA approved drawings affected by this CCD: S-211, S-400 |

| DSA USE ONLY | DSA Stamp | | | | | | | | | | |
|--|---|--|--------|-----------------|--|--|--|-----------------|--|---------------------------------|--|
| SSS_ST Date 1/02/18 <input checked="" type="radio"/> Approved / Disapproved / Not Req'd FLS Date _____ <input checked="" type="radio"/> Approved / Disapproved / Not Req'd ACS Date _____ <input checked="" type="radio"/> Approved / Disapproved / Not Req'd Remarks _____ | <table border="1"> <tr> <td></td> <td style="text-align: right;">stuong</td> </tr> <tr> <td colspan="2" style="text-align: center;">APPROVED</td> </tr> <tr> <td colspan="2" style="text-align: center;">DIV. OF THE STATE ARCHITECT LOS ANGELES REGIONAL OFFICE</td> </tr> <tr> <td colspan="2" style="text-align: center;">DATE 01/02/2018</td> </tr> <tr> <td colspan="2" style="text-align: center;">Appl. No: 03-116806 140_012.pdf</td> </tr> </table> |  | stuong | APPROVED | | DIV. OF THE STATE ARCHITECT LOS ANGELES REGIONAL OFFICE | | DATE 01/02/2018 | | Appl. No: 03-116806 140_012.pdf | |
|  | stuong | | | | | | | | | | |
| APPROVED | | | | | | | | | | | |
| DIV. OF THE STATE ARCHITECT LOS ANGELES REGIONAL OFFICE | | | | | | | | | | | |
| DATE 01/02/2018 | | | | | | | | | | | |
| Appl. No: 03-116806 140_012.pdf | | | | | | | | | | | |

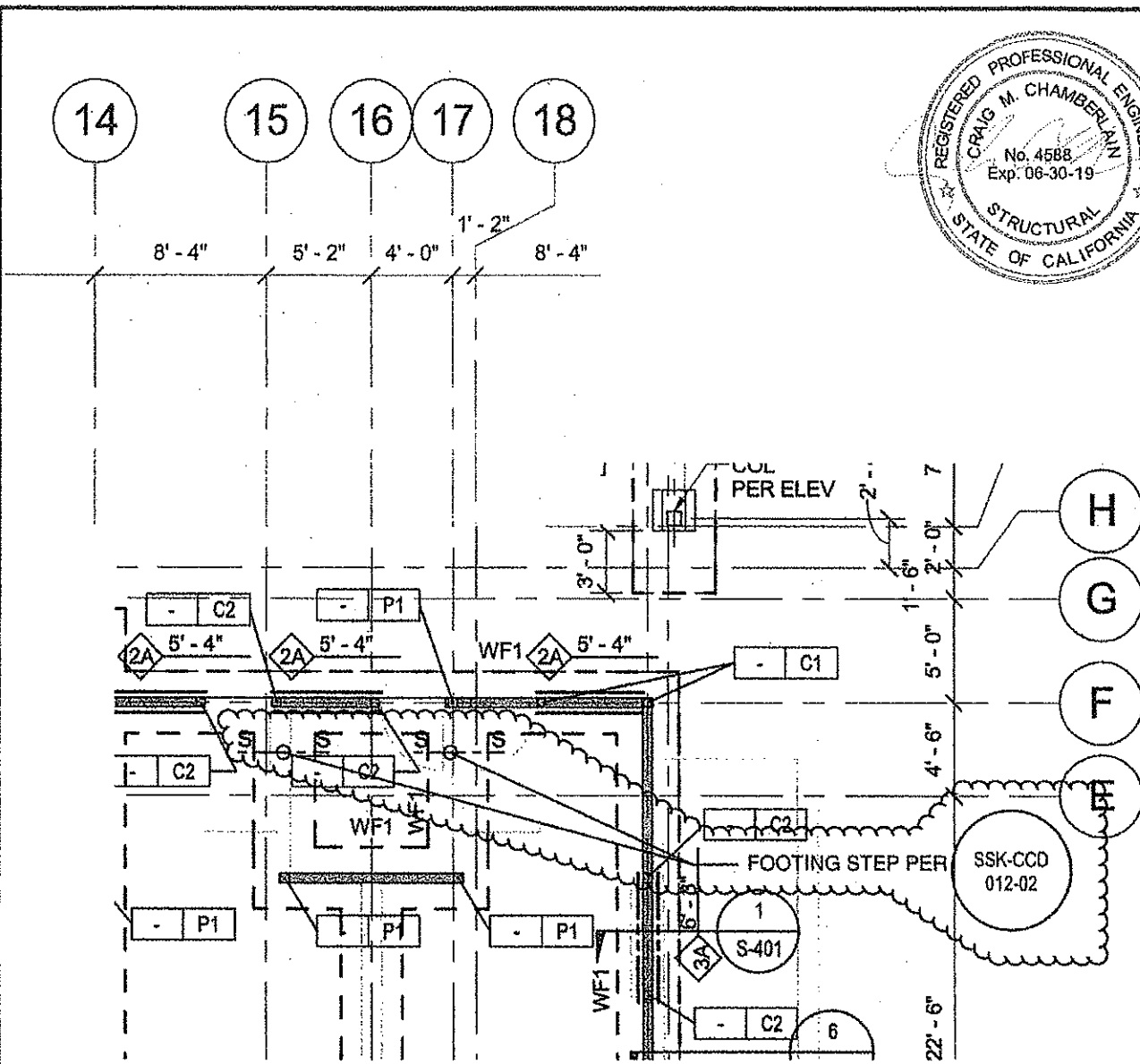
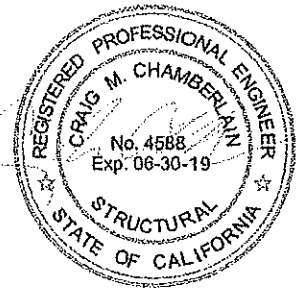

 **APPROVED** stuong
 DIV. OF THE STATE ARCHITECT
 LOS ANGELES REGIONAL OFFICE
 DATE 01/02/2018
 Appl. No: 03-116806 140 012.pdf

REVISED PARTIAL PLAN

Description of change:
 Partial plan that denotes location where stepped footing detail is to be modified per following sketch.
 referenced drawings/details: S-211, SSK-CCD012-02

NISHKIAN CHAMBERLAIN
 CONSULTING AND STRUCTURAL ENGINEERS SINCE 1919
 NC PROJECT #: 40340

CSDA PROJECT #: 1534.01
 MARSHALL ES - NEW CLASSROOM BUILDING
 2900 Thurgood Marshall Dr, Oxnard, CA 93036

SHEET: 01 OF 02
 DRAWING REFERENCE: S-211
 SCALE: NTS
 DATE: 12/14/2017

CSDA DESIGN GROUP

DSA A# 03-116806

Title of sheet
 Revised Partial Plan S-211

CCD #012

SSK-CCD012-01

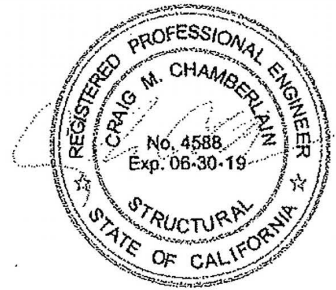

FOOTING REBAR TO REMAIN CONTINUOUS

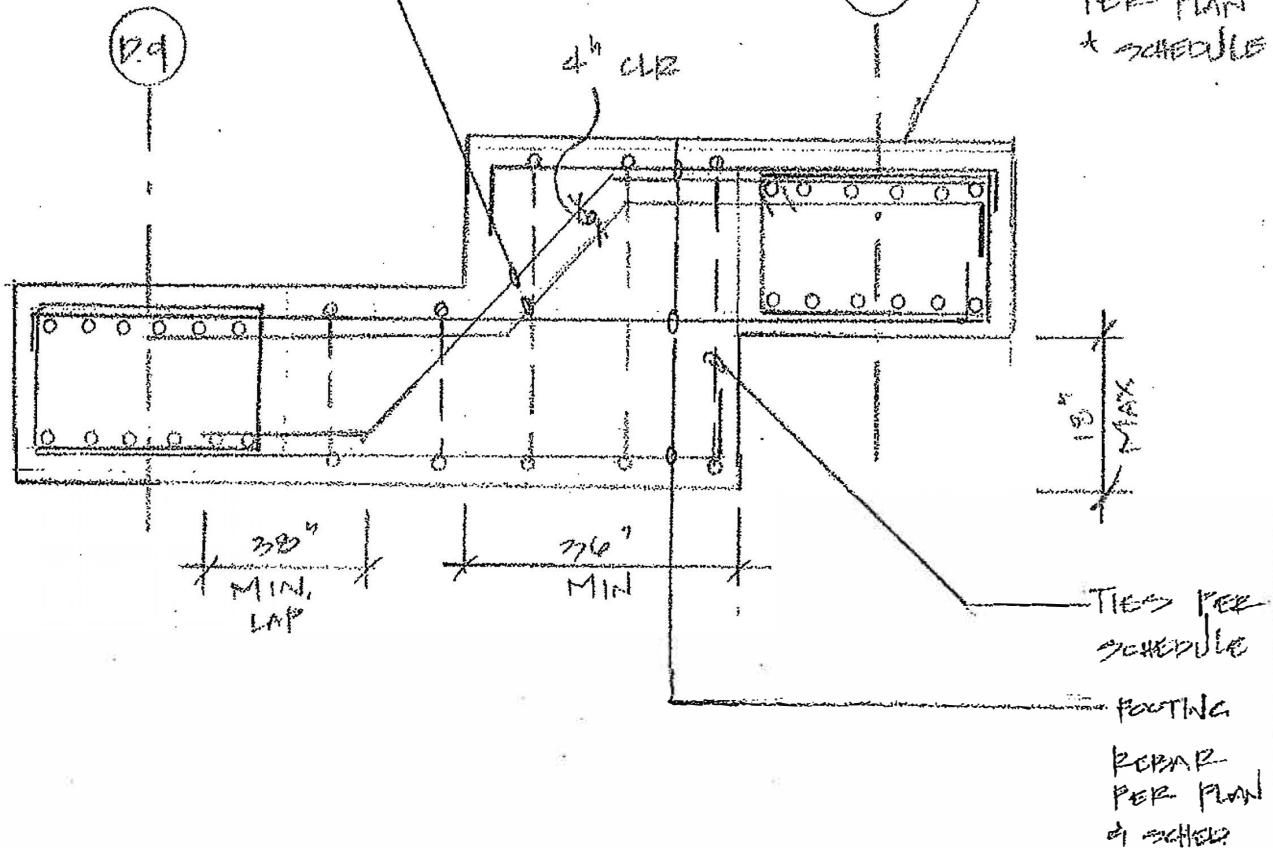

DSA APPROVED sluong
 DIV. OF THE STATE ARCHITECT
 LOS ANGELES REGIONAL OFFICE
 DATE 01/02/2018
 Appl. No: 03-116806 140 012.pdf

REVISED DETAIL

Description of change:

Existing detail is modified to reduce required lap splice length at locations specified in SSK-CCD012-01.

referenced drawings/details: 16/S-400, S-211, SSK-CCD012-01

**NISHKIAN
 CHAMBERLAIN**

CONSULTING AND STRUCTURAL
 ENGINEERS SINCE 1919

NC PROJECT #: 40340

| | | |
|--|--|--------------------------|
| CSDA PROJECT #: 1534.01 MARSHALL ES - NEW CLASSROOM BUILDING 2900 Thurgood Marshall Dr, Oxnard, CA 93036 | SHEET: 02 OF 02 DRAWING REFERENCE: 16/S-400 SCALE: NTS DATE: 12/14/2017 | CSDA DESIGN GROUP |
| DSA A# 03-116806 | Title of sheet Revised Stepped Footing Detail 16/S-400 | |
| SSK-CCD012-02 | | |



CHANGE ORDER REQUEST

COR No. 14 R0
Date: 3/22/2018

Project: Marshall Elementary - New 6-8 Classroom Bldg.

DESCRIPTION OF WORK

CCD 008 - Rebar

SUMMARY OF COSTS

| Item Description | Company | Amount Requested |
|---|----------------|------------------|
| Subcontract Costs | | |
| CCD 8 Grade beam BG42 add 8 hold down @ 42 | Vista Steel Co | 488 |
| CCD 008 - Tie and cap @ hold down locations | Vista Steel Co | 941 |
| | Subtotal: | 1,429 |
| Total Change Order Request Amount: | | 1,429 |

APPROVAL

(Please note that if this Change Order Request is not approved by , additional costs and schedule impacts may result)

Oxnard School District

Bernards Bros. Inc.

Signature

Signature

Printed Name & Title

Printed Name & Title

Date

Date

Jennifer McJannet
CFW Program Mgr

VISTA Steel Company

February 2, 2018

BERNARDS BUILDERS MGT
 555 FIRST STREET
 SAN FERNANDO, CA 91340

Project: MARSHALL NEW CLASSROOM

Re: VT1804
 CC#12

Gentlemen,

Following is the description and breakdown for the above referenced additional charge:

| CC# 12 | | Grade Beams GB42 added 8 hold down rebars to grade beam 42 | | | |
|---------------------|-----|--|--|-----------|------------|
| | QTY | UOM | | | |
| Fabricated material | 0 | LBS | | \$ | - |
| Detailing | | HRS | | \$ | - |
| Cartage | | HRS | | \$ | - |
| Installation | | HRS | | \$ | - |
| Premium Time | 4 | HRS | | \$ | 423.96 |
| Subsistence | 0 | DAYS | | \$ | - |
| Accessories | | LS | | \$ | - |
| SUBTOTAL | | | | \$ | 423.96 |
| Overhead 15% | | | | \$ | 63.59 |
| SUBTOTAL | | | | \$ | 487.55 |
| Profit | | | | \$ | - |
| TOTAL | | | | \$ | 488 |

This change will appear and become due with your next invoice. If this change is the responsibility of the owner we request that you process it immediately.

Respectfully submitted,

VISTA Steel Company

Iqbal Toor

Iqbal Toor
 Contract Administrator

VISTA Steel Company

331 West Lewis
Ventura, California 93001
(805) 653-1109

CONTRACT CHANGE # CCO # 17
 MISCELLANEOUS RECORDS
JOB NUMBER VH/809

CONTRACT CHANGE:

WE HEREBY AUTHORIZE VISTA STEEL COMPANY TO PERFORM THE FOLLOWING WORK ON THE JOBSITE AS DESCRIBED BELOW AND AGREE TO ACCEPT REASONABLE CHARGES FOR THE WORK PERFORMED:

DESCRIPTION OF WORK:

Grade Beam GB42
Added 2 Hold Down Bars to Grade Beam 42

IMMEDIATE LABOR AND/OR MATERIALS FURNISHED:

| | REGULAR | FULL/PREMIUM | |
|------------|---------------|--------------|-------|
| SUPERVISOR | _____ HRS. | _____ HRS. | _____ |
| FOREMAN | <u>4</u> HRS. | _____ HRS. | _____ |
| JOURNEYMAN | _____ HRS. | _____ HRS. | _____ |
| OTHER | _____ HRS. | _____ HRS. | _____ |

WORK IN PROGRESS WORK COMPLETED

MISCELLANEOUS RECORDS:

THE UNDERSIGNED AGREES THAT THE HEREINAFTER DESCRIBED CIRCUMSTANCES AND/OR FACTS ARE CORRECT AND ASSUMES FULL RESPONSIBILITY FOR ANY FUTURE DEVELOPMENT WHICH COULD ORIGINATE ON THEM:

Marshall New Classroom Bernards Builders
PROJECT CONTRACTOR
Oxford Will Van Zee
LOCATION PRINT
2/1/18 Will Van Zee 02-01-18
DATE VISTA'S REPRESENTATIVE BY SIGN
Monte Rice

VISTA Steel Company

January 4, 2018

BERNARDS BUILDERS MGT
555 FIRST STREET
SAN FERNANDO, CA 91340

Project: MARSHALL NEW CLASSROOM

Re: **VT1804**
CC#6

Gentlemen,

Following is the description and breakdown for the above referenced additional charge:

CC# 6 Adding Ties & Caps @ hold down location at the request of the contractor

| | QTY | UOM | | |
|---------------------|------|------|-----------|------------|
| Fabricated material | 177 | LBS | \$ | 129.21 |
| Detailing | 0.00 | HRS | \$ | - |
| Cartage | 0.50 | HRS | \$ | 42.50 |
| Installation | 8 | HRS | \$ | 646.56 |
| Subsistance | 0 | DAYS | \$ | - |
| Accessories | | LS | \$ | - |
| SUBTOTAL | | | \$ | 818.27 |
| Overhead 15% | | | \$ | 122.74 |
| SUBTOTAL | | | \$ | 941.01 |
| Profit | | | \$ | - |
| TOTAL | | | \$ | 941 |

This change will appear and become due with your next invoice. If this change is the responsibility of the owner we request that you process it immediately.

Respectfully submitted,

VISTA Steel Company

Iqbal Toor

Iqbal Toor
Contract Administrator

VISTA Steel Company

331 West Lewis
Ventura, California 93001
(805) 653-1189

CONTRACT CHANGE # 0100#6
 MISCELLANEOUS RECORDS
 JOB NUMBER V71804

CONTRACT CHANGE:

WE HEREBY AUTHORIZE VISTA STEEL COMPANY TO PERFORM THE FOLLOWING WORK ON THE JOBSITE AS DESCRIBED BELOW AND AGREE TO ACCEPT REASONABLE CHARGES FOR THE WORK PERFORMED:

DESCRIPTION OF WORK:

*Adding Holes and CAP's At Hold Down Location
 At the Request of Contractor Bernard's
 The layout for the Hold Downs were not done
 Before placement of Beam Iron*

IMMEDIATE LABOR AND/OR MATERIALS FURNISHED:

| | REGULAR | FULL/PREMIUM | | |
|------------|---------------|--------------|------------------|----------------|
| SUPERVISOR | _____ HRS. | _____ HRS. | <i>#4 21 3/4</i> | <i>133 lbs</i> |
| FOREMAN | <i>8</i> HRS. | _____ HRS. | <i>21 3/4</i> | <i>44</i> |
| JOURNEYMAN | _____ HRS. | _____ HRS. | | <i>1 1/2</i> |
| OTHER | _____ HRS. | _____ HRS. | | |

WORK IN PROGRESS WORK COMPLETED

MISCELLANEOUS RECORDS:

THE UNDERSIGNED AGREES THAT THE HEREINAFTER DESCRIBED CIRCUMSTANCES AND/OR FACTS ARE CORRECT AND ASSUMES FULL RESPONSIBILITY FOR ANY FUTURE DEVELOPMENT WHICH COULD ORIGINATE ON THEM:

| | |
|-------------------------------|------------------------|
| <i>Marshall New Classroom</i> | <i>Bernard's Const</i> |
| PROJECT | CONTRACTOR |
| <i>OXNard</i> | <i>Will Van Zee</i> |
| LOCATION | PRINT |
| <i>12/18</i> | <i>01-02-10</i> |
| DATE | SIGN |
| <i>[Signature]</i> | <i>[Signature]</i> |
| VISTA'S REPRESENTATIVE | BY |

APPLICATION FOR APPROVAL OF CONSTRUCTION CHANGE DOCUMENT - CCD CATEGORY A/B

This application is for construction changes, as defined in IR A-6, to approved contract documents. This form shall be completed by the Design Professional in General Responsible Charge of the project, in accordance with California Code of Regulations, Title 24, Part 1, Section 4-338 (c) and in compliance with DSA IR A-6.

| | |
|--|-------------------------|
| School District/Owner: Oxnard School District | DSA File #: 56 - 22 |
| Project Name/School: Marshall Elementary School New Classroom Building | DSA App. #: 03 - 116806 |

| APPLICANT | | |
|---|------------------------------|---|
| CCD Cat. <input checked="" type="checkbox"/> A / <input type="checkbox"/> B, #008 | Date Submitted: 11/06/17 | Attached Pages?: <input type="checkbox"/> No <input checked="" type="checkbox"/> Yes (34 pages) |
| For CCD Cat. B, this is a <input type="checkbox"/> voluntary submittal, <input type="checkbox"/> DSA required submittal (attach DSA notification requiring submission). | | |
| Firm Name: CSDA Design Group | Contact Name: Michael Schoen | |
| Email: mschoen@csdadesigngroup.com | Phone Number: (310) 301-4772 | |
| Address: 889 N Douglas St, Suite 100 | | |
| City: El Segundo | State: CA | Zip: 90245 |
| <input type="checkbox"/> A DSA 301-N, DSA 301-P, or 90-Day Letter has been issued for this project. | | |
| <input checked="" type="checkbox"/> For project currently under construction. | | |
| <input type="checkbox"/> To obtain DSA approval of existing uncertified building(s). | | |

| DESIGN PROFESSIONAL IN GENERAL RESPONSIBLE CHARGE | |
|---|-----------------------|
| Name of Design Professional in General Responsible Charge: Michael Schoen | |
| Professional License #: C-35165 | Discipline: Architect |
| Design Professional in General Responsible Charge Statement: The attached Construction Change Documents have been examined by me for design intent and appear to meet the appropriate requirements of Title 24, California Code of Regulations and the project specifications. They are acceptable for incorporation into the construction of the project. | |
| Signature:  | |
| DESIGN PROFESSIONAL IN GENERAL RESPONSIBLE CHARGE | |

| |
|--|
| CHECK THIS BOX: <input checked="" type="checkbox"/> To confirm that all CCD drawings and, when applicable, first sheet or index of calculations and specifications have been stamped and signed by the Responsible Design Professional listed on DSA 1 for this this project. |
| Brief description of construction change (attach additional sheets if needed): Revised details on structural sheets (20/ S-600, 17 and 18/ S-401) to show supplemental reinforcement to prevent concrete break-out at locations of high loading |
| List of DSA approved drawings affected by this CCD: S-600, S-401, S-211 |

| DSA USE ONLY | | APPROVED | |
|---|--|--|--|
| SSS _____ Date _____ Approved / Disapproved / Not Req'd | <small>For business office use only</small> Date Sent _____ Return By _____ Delivery Method _____ |  chlin DIV. OF THE STATE ARCHITECT LOS ANGELES REGIONAL OFFICE | |
| FLS _____ Date _____ Approved / Disapproved / Not Req'd | | DATE <u>11/16/2017</u> | |
| ACS _____ Date _____ Approved / Disapproved / Not Req'd | | Appl. No: 03-116806 140 08 SSS.pdf | |
| Remarks _____ | | | |

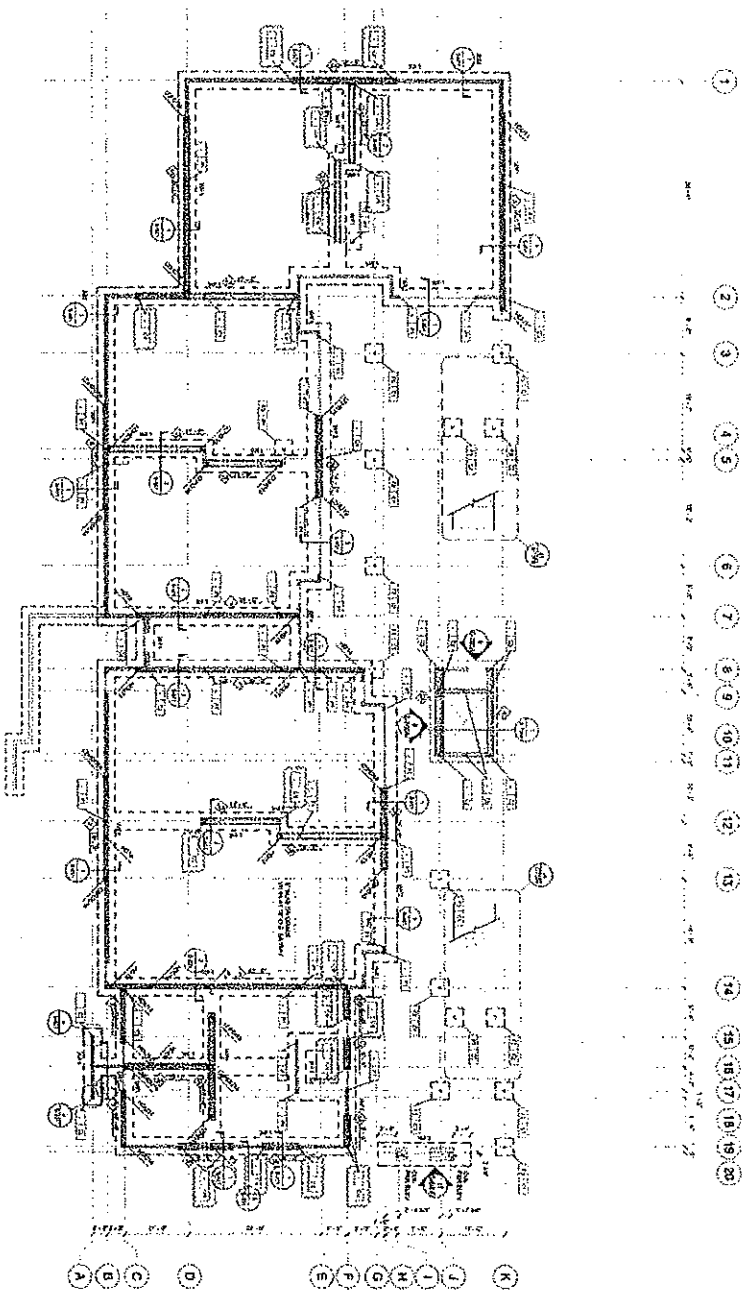

1 FOUNDATION PLAN

APPROVED
 DIVISION OF STATE ARCHITECTURE
 DATE: 11/28/2017
 NAME: SSK-C-CDD008-01

Occupation of structure
 Revised plan shall show locations where supplemental
 reinforcement is required to prevent concrete break-out.
 Reference: demconcrete.com 211.17 SSK-C-CDD008-01, 2005-2007

SSK-C-CDD008-01

- 1. ALL WALLS AND PARTITIONS SHALL BE CONCRETE ON A 12" MIN. THICK FOUNDATION.
- 2. ALL FOUNDATION SHALL BE 12" MIN. THICK.
- 3. ALL FOUNDATION SHALL BE 12" MIN. THICK.
- 4. ALL FOUNDATION SHALL BE 12" MIN. THICK.
- 5. ALL FOUNDATION SHALL BE 12" MIN. THICK.
- 6. ALL FOUNDATION SHALL BE 12" MIN. THICK.
- 7. ALL FOUNDATION SHALL BE 12" MIN. THICK.
- 8. ALL FOUNDATION SHALL BE 12" MIN. THICK.
- 9. ALL FOUNDATION SHALL BE 12" MIN. THICK.
- 10. ALL FOUNDATION SHALL BE 12" MIN. THICK.
- 11. ALL FOUNDATION SHALL BE 12" MIN. THICK.
- 12. ALL FOUNDATION SHALL BE 12" MIN. THICK.
- 13. ALL FOUNDATION SHALL BE 12" MIN. THICK.
- 14. ALL FOUNDATION SHALL BE 12" MIN. THICK.
- 15. ALL FOUNDATION SHALL BE 12" MIN. THICK.
- 16. ALL FOUNDATION SHALL BE 12" MIN. THICK.
- 17. ALL FOUNDATION SHALL BE 12" MIN. THICK.
- 18. ALL FOUNDATION SHALL BE 12" MIN. THICK.
- 19. ALL FOUNDATION SHALL BE 12" MIN. THICK.
- 20. ALL FOUNDATION SHALL BE 12" MIN. THICK.

CSDA DESIGN
 2017-2018
 11/28/2017



HICKMAN COUNTY
 CLAYTON BENTLEY
 COMMISSIONER



OAKLAND SCHOOL DISTRICT

MASSHALL NEW CLASSROOM BUILDING

NO. 2017-2018
 DATE: 11/28/2017
 NAME: SSK-C-CDD008-01

FOUNDATION PLAN

S 211

| HOLLOW (1/2)IN | POST SIZE (OEN) | MIN ANCHOR ROD DIA | MIN ANCHOR ROD LENG |
|----------------|-----------------|--------------------|---------------------|
| HOU-002.5 | 3.2x5W | 5/8" | 12" |
| HOU-002.5 | 3.2x5W | 5/8" | 12" |
| HOU-002.5 | 3.2x5W | 7/8" | 12" |
| HOU-1-002.5 | 4.2x5W | 1" | 12" |
| HOU-4-002.5 | 4.2x5W | 1 1/4" | 12" |
| HOU-8 | 4.2x5W | 1 1/2" | 12" |

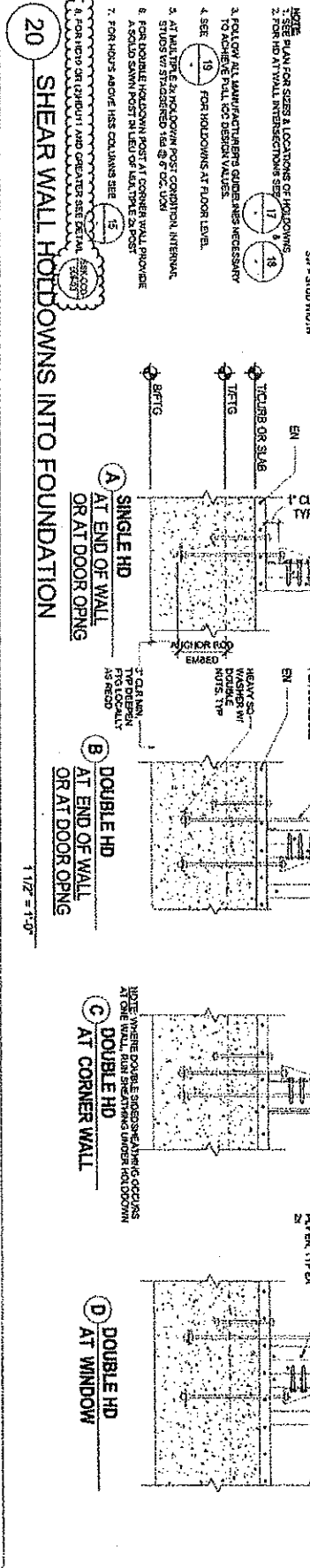

REVISED DETAIL

Description of change:
 Revised detail to show supplemental reinforcement to prevent concrete break-out at locations of high loading.
 referenced drawings/details: 20/S-600

CSDA PROJECT #: 1534.01
 MARSHALL ES - NEW CLASSROOM BUILDING
 2900 Thurgood Marshall Dr, Oxnard, CA 93036
 DSA A# 03-116806

SHEET: 2 OF 34
 DRAWING REFERENCE: 20/S-600
 SCALE: NTS
 DATE: 11/02/2017
 Title of sheet: REVISED DETAIL

NISHKIAN CHAMBERLAIN
 CONSULTING AND STRUCTURAL ENGINEERS SINCE 1919
 NC PROJECT #: 40340
 CCD # 008

CSDA DESIGN GROUP
 SSK-CCD008-02

APPROVED
 DIV. OF THE STATE ARCHITECT
 LOS ANGELES REGIONAL OFFICE
 DATE 11/16/2017
 Appl. No. 03-116806 197 DR. SSS:cd

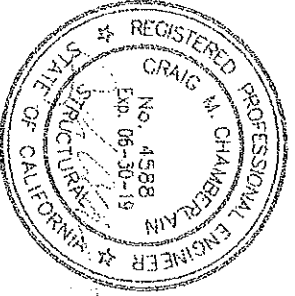

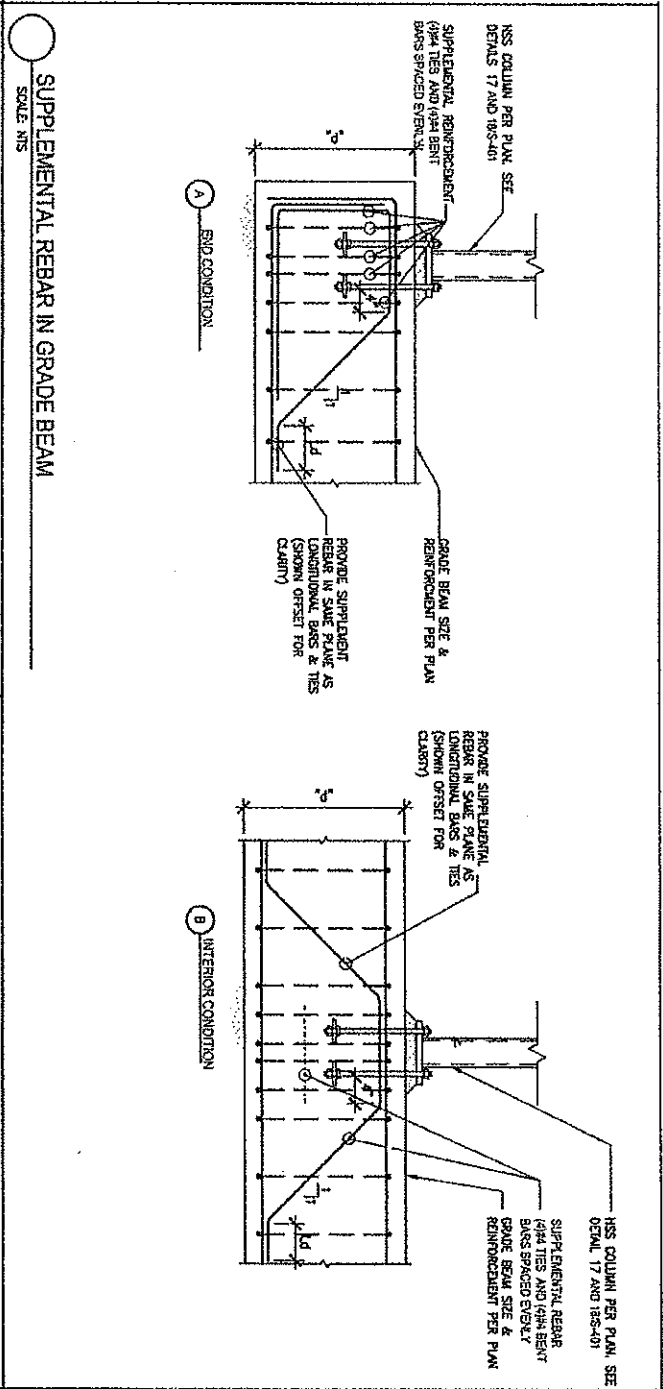

NEW DETAIL

Description of change:
 New detail to show supplemental reinforcement to prevent concrete break-out at locations of high loading.

referenced drawings/details: S-211, 20/S-600, 17 and 18/S-401

CSDA PROJECT #: 1534.01
 MARSHALL ES - NEW CLASSROOM BUILDING
 2900 Thurgood Marshall Dr, Oxnard, CA 93036

SHEET: 3 OF 34
 DRAWING REFERENCE: S-211, 20/S-600, 17 and 18/S-401
 SCALE: NTS
 DATE: 11/02/2017

DSA A# 03-116806

Title of sheet: NEW DETAIL

CCD # 008

SSK-CCD008-03

DSA APPROVED *chfn*
 DIV. OF THE STATE ARCHITECT
 LOS ANGELES REGIONAL OFFICE
 DATE 11/16/2017
 Appl. No: 03-116806 140 08 SSS.pdf



NISHKIAN CHAMBERLAIN
 CONSULTING AND STRUCTURAL ENGINEERS SINCE 1979
 NC PROJECT #: 40340

CSDA DESIGN GROUP

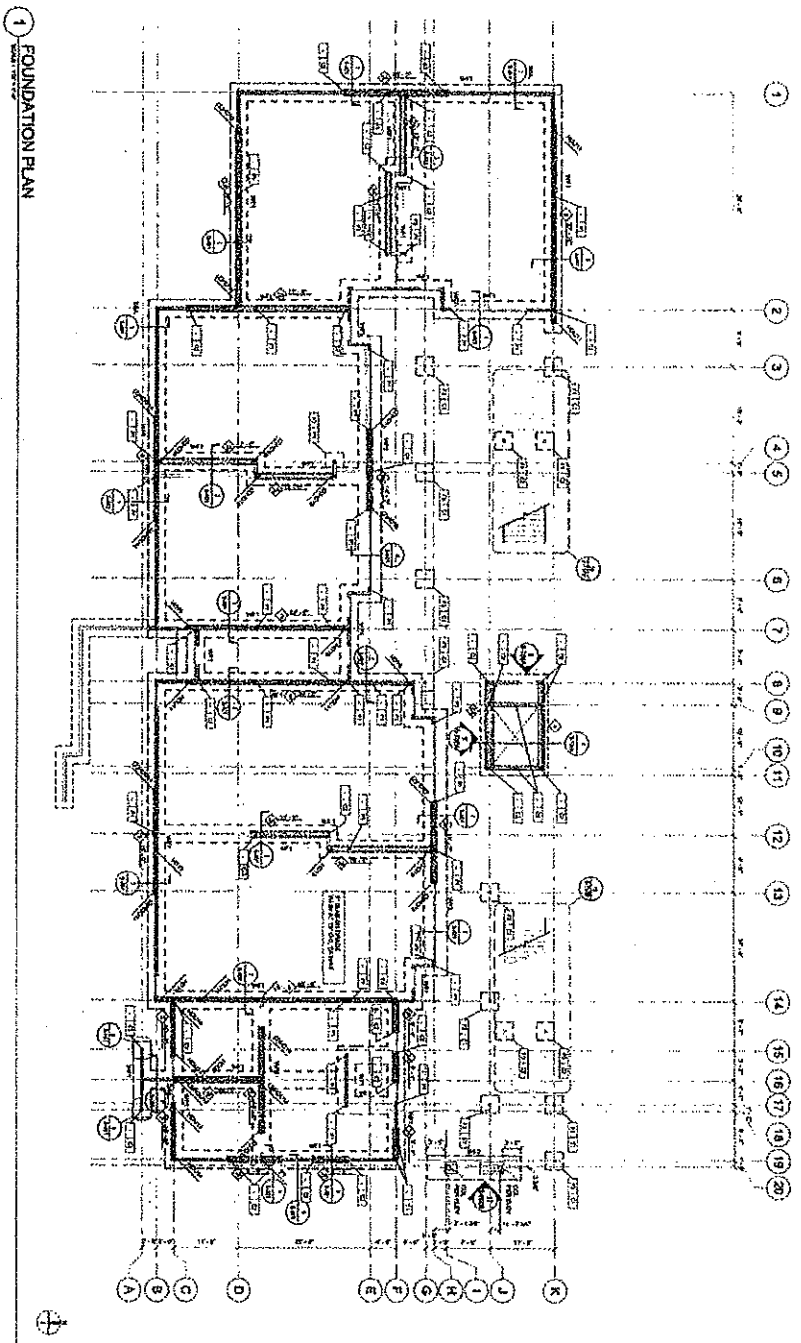

1 FOUNDATION PLAN

- 1. FOUNDATION PLAN
- 2. FOUNDATION PLAN
- 3. FOUNDATION PLAN
- 4. FOUNDATION PLAN
- 5. FOUNDATION PLAN
- 6. FOUNDATION PLAN
- 7. FOUNDATION PLAN
- 8. FOUNDATION PLAN
- 9. FOUNDATION PLAN
- 10. FOUNDATION PLAN
- 11. FOUNDATION PLAN
- 12. FOUNDATION PLAN
- 13. FOUNDATION PLAN
- 14. FOUNDATION PLAN
- 15. FOUNDATION PLAN
- 16. FOUNDATION PLAN
- 17. FOUNDATION PLAN
- 18. FOUNDATION PLAN
- 19. FOUNDATION PLAN
- 20. FOUNDATION PLAN

CSDA DESIGN
 4815 University Ave., Suite 400
 Dallas, Texas 75249
 Phone: (214) 343-1111
 www.csdadesign.com



MISHALEH CHAMBERSLAW
 ARCHITECTS & INTERIORS
 10000 Preston Road, Suite 1000
 Dallas, Texas 75249
 Phone: (214) 343-1111
 www.mishalehchamberslaw.com

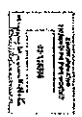

OXNARD SCHOOL DISTRICT
 1000 Oxnard Blvd.
 Oxnard, CA 93030
 Phone: (805) 325-1000
 www.oxnardschools.org

MARSHALL NEW CLASSROOM BUILDING
 1000 Oxnard Blvd.
 Oxnard, CA 93030
 Phone: (805) 325-1000

| NO. | DESCRIPTION | DATE |
|-----|-----------------|------------|
| 1 | FOUNDATION PLAN | 02/15/2011 |
| 2 | FOUNDATION PLAN | 02/15/2011 |
| 3 | FOUNDATION PLAN | 02/15/2011 |
| 4 | FOUNDATION PLAN | 02/15/2011 |
| 5 | FOUNDATION PLAN | 02/15/2011 |
| 6 | FOUNDATION PLAN | 02/15/2011 |
| 7 | FOUNDATION PLAN | 02/15/2011 |
| 8 | FOUNDATION PLAN | 02/15/2011 |
| 9 | FOUNDATION PLAN | 02/15/2011 |
| 10 | FOUNDATION PLAN | 02/15/2011 |
| 11 | FOUNDATION PLAN | 02/15/2011 |
| 12 | FOUNDATION PLAN | 02/15/2011 |
| 13 | FOUNDATION PLAN | 02/15/2011 |
| 14 | FOUNDATION PLAN | 02/15/2011 |
| 15 | FOUNDATION PLAN | 02/15/2011 |
| 16 | FOUNDATION PLAN | 02/15/2011 |
| 17 | FOUNDATION PLAN | 02/15/2011 |
| 18 | FOUNDATION PLAN | 02/15/2011 |
| 19 | FOUNDATION PLAN | 02/15/2011 |
| 20 | FOUNDATION PLAN | 02/15/2011 |

S-211

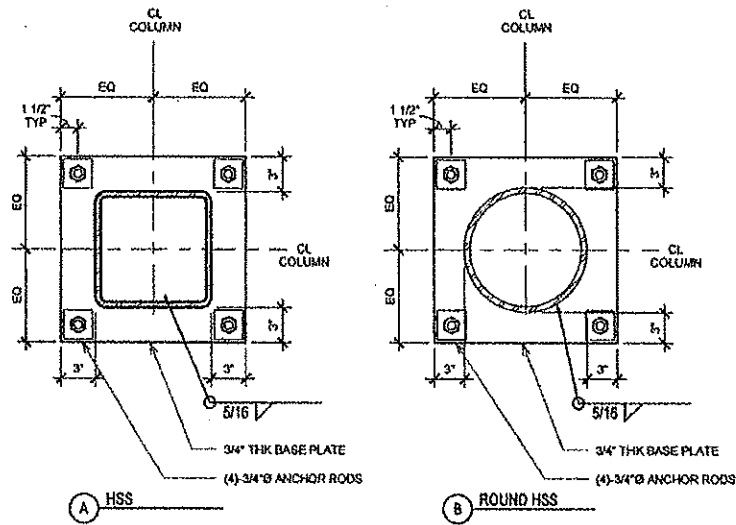

NOTE:
 1. SEE TYPICAL ANCHOR ROD DETAIL FOR ANCHOR ROD, OVERSIZED HOLE AND WASHER REQUIREMENTS.

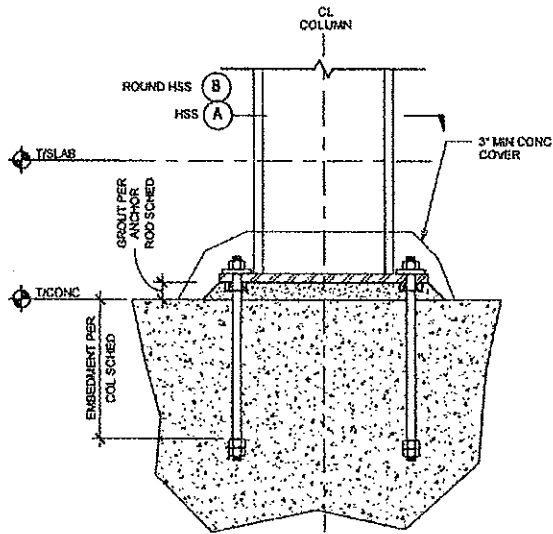

18 TYPICAL BASE PLATE DETAIL
 SCALE: 1 1/2" = 1'-0"

DETAIL 18/S-401
 (FROM DSA APPROVED PLANS)
 FOR REFERENCE ONLY

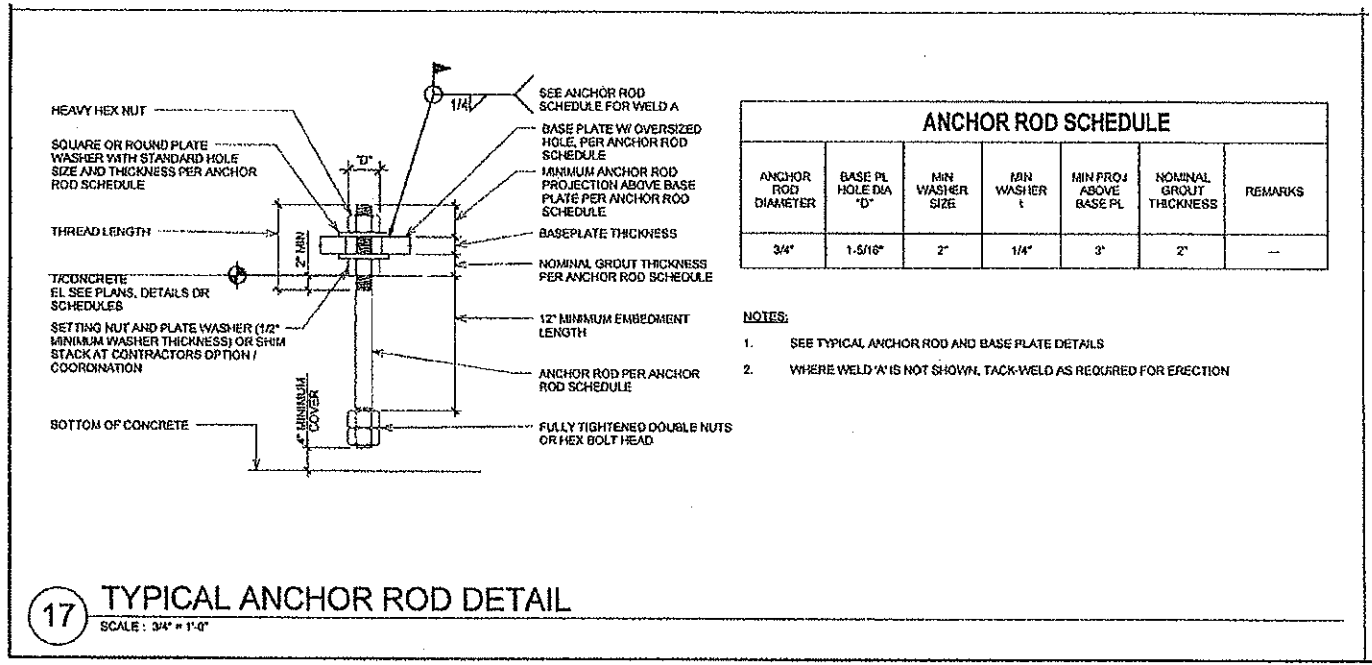

| ANCHOR ROD SCHEDULE | | | | | | |
|---------------------|----------------------|-----------------|--------------|------------------------|-------------------------|---------|
| ANCHOR ROD DIAMETER | BASE PL HOLE DIA "D" | MIN WASHER SIZE | MIN WASHER t | MIN PROJ ABOVE BASE PL | NOMINAL GROUT THICKNESS | REMARKS |
| 3/4" | 1-5/16" | 2" | 1/4" | 3" | 2" | — |

- NOTES:**
- SEE TYPICAL ANCHOR ROD AND BASE PLATE DETAILS
 - WHERE WELD 'A' IS NOT SHOWN, TACK-WELD AS REQUIRED FOR ERECTION

DETAIL 17/S-401
 (FROM DSA APPROVED PLANS)
 FOR REFERENCE ONLY

| HOLD-DOWN (1/2"x10") | POST SIZE UO/W | MIN ANCHOR ROD DIA | MIN ANCHOR ROD EMBED |
|----------------------|----------------|--------------------|----------------------|
| HOLD-SOZ.5 | 2-2x SW | 5/8" | 12" |
| HOLD-SOZ.5 | 3-2x SW | 5/8" | 12" |
| HOLD-SOZ.5 | 3-2x SW | 7/8" | 12" |
| HOLD-SOZ.5 | 4-2x SW | " | 12" |
| HOLD-SOZ.5 | 1-4x | " | 12" |
| HOLD | 1-4x | 1-1/4" | 12" |

SW = STUD WIDTH

- NOTE:
- SEE PLAN FOR SIZES & LOCATIONS OF HOLD-DOWNS.
 - FOR HD AT WALL INTERSECTIONS SEE 17 & 18
 - FOLLOW ALL MANUFACTURER'S GUIDELINES NECESSARY TO ACHIEVE FULL ICC DESIGN VALUES.
 - SEE 19 FOR HOLD-DOWNS AT FLOOR LEVEL.
 - AT MULTIPLE 2x HOLD-DOWN POST CONDITION, INTERNAL STUDS @ 4" O.C. ON
 - FOR DOUBLE HOLD-DOWN POST AT CORNER WALL PROVIDE A SOLID SWAN POST IN LIEU OF MULTIPLE 2x POST
 - FOR HD'S ABOVE HSS COLUMNS SEE 15

20 SHEAR WALL HOLD-DOWNS INTO FOUNDATION

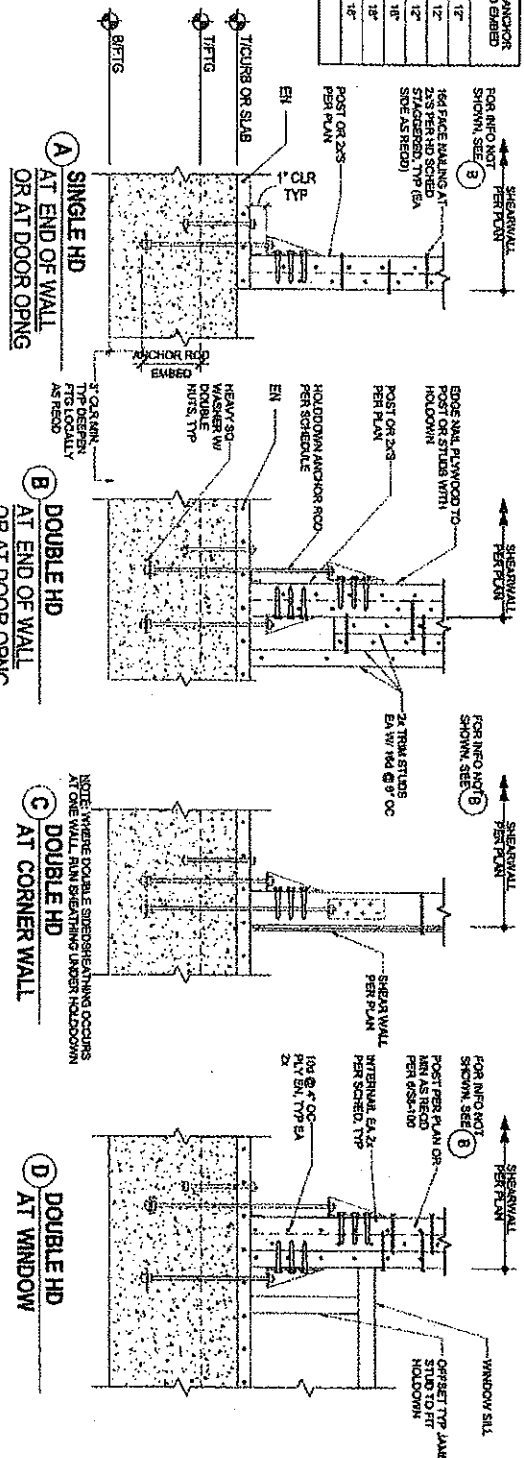

DETAIL 2015-600
 (FROM DSA APPROVED PLANS)
 FOR REFERENCE ONLY

ANCHORAGE DESIGN

DESIGN LOADS

| HDU | ALLOWABLE TENSION (KIPS) | ALLOW. TENS (LIPS) | EMBED (PER-SCHED) | BEARING PLATE REQ'D? |
|-------|--------------------------|---------------------|-------------------|----------------------|
| HDU4 | 4565 ^{lb} | 6001 ^{lb} | 12" | YES |
| HDU5 | 5645 ^{lb} | 7902 ^{lb} | 12" | YES |
| HDU8 | 6765 ^{lb} | 9471 ^{lb} | 12" | YES |
| HDU11 | 1175 ^{lb} | 15645 ^{lb} | 18" | YES |
| HDU14 | 14445 ^{lb} | 20223 ^{lb} | 12" | YES |
| HDU19 | 19070 ^{lb} | 24690 ^{lb} | 18" | YES |

*NOTE: DESIGN INTENT IS TO DETERMINE STRENGTH OF ANCHORS & ENSURE DUCTILE FAILURE (I.E. STEEL STRENGTH < CONCRETE PULLOUT). THE USE OF "D" AS REQ'D PER APP.D § D.2.2.4 IS THIS AVOIDED.

ADDL BREAKOUT REINFORCEMENT

PER § D.S.2.9, ACI 318; REBAR CAN BE USED TO DETERMINE STRENGTH OF CONCRETE BREAK-OUT PROVIDED A REDUCTION OF 0.75 (φ) IS APPLIED.

NOTE: EFFECTIVE AREA IS THE AREA OF EACH BAR USED FOR REBAR

| HDU | STEEL STRENGTH GOVERNS? | REBAR REQUIRED? | No. of BARS REQ'D |
|-------------|-------------------------|-----------------|-------------------|
| HDU4 | Y | N | N/A |
| HDU5 | Y | N | N/A |
| HDU8 | Y | N | N/A |
| HDU11 | Y | N | N/A |
| HDU14 | Y | N | N/A |
| HDU19 | Y | Y | (4) #5 BARS |
| HD5 COL 5X5 | Y | Y | (4) #5 BARS GR.60 |

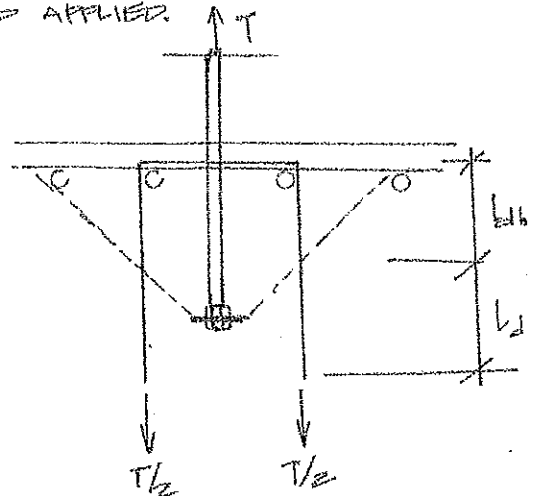



Anchor Designer™
Software
Version 2.5.6163.2

| | | | |
|-----------|---|-------|------------|
| Company: | Nishkian Chamberlain | Date: | 10/19/2017 |
| Engineer: | | Page: | 1/4 |
| Project: | | | |
| Address: | 3710 S. Robertson Blvd, Culver City, CA 90232 | | |
| Phone: | 310-853-7180 | | |
| E-mail: | | | |

1. Project Information

Customer company:
Customer contact name:
Customer e-mail:
Comment:

HDU5

Project description:
Location:
Fastening description:

A#03-116806
CCD008
SHEET 9 OF 34

2. Input Data & Anchor Parameters

General

Design method: ACI 318-11
Units: Imperial units

Anchor Information:

Anchor type: Cast-in-place
Material: AB
Diameter (Inch): 0.625
Effective Embedment depth, h_{ef} (Inch): 12.000
Anchor category: -
Anchor ductility: Yes
 h_{min} (Inch): 14.13
 C_{min} (Inch): 3.75
 S_{min} (Inch): 3.75

Base Material

Concrete: Normal-weight
Concrete thickness, h (Inch): 30.00
State: Cracked
Compressive strength, f'_c (psi): 3000
 $\psi_{e,v}$: 1.0
Reinforcement condition: B tension, B shear
Supplemental reinforcement: Not applicable
Reinforcement provided at corners: No
Do not evaluate concrete breakout in tension: No
Do not evaluate concrete breakout in shear: No
Ignore ϕ_{dc} requirement: No
Build-up grout pad: No

Load and Geometry

Load factor source: ACI 318 Section 9.2
Load combination: not set
Seismic design: Yes
Anchors subjected to sustained tension: Not applicable
Ductility section for tension: D.3.3.4.2 not applicable
Ductility section for shear: not satisfied
 Ω_F factor: not set
Apply entire shear load at front row: Yes
Anchors only resisting wind and/or seismic loads: Yes

<Figure 1>

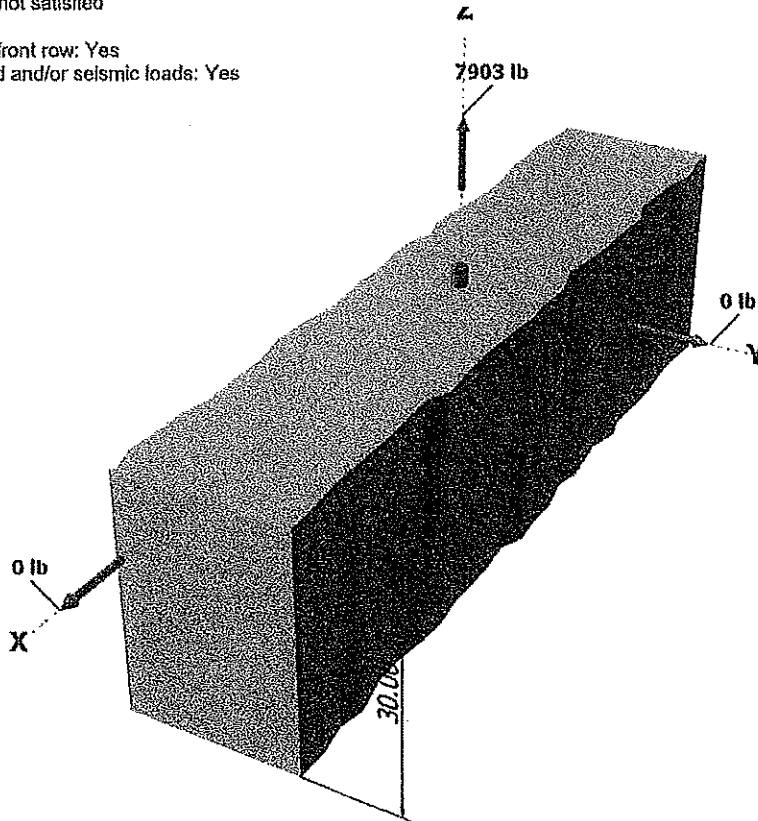

| | | | |
|-----------|---|-------|------------|
| Company: | Nishkian Chamberlain | Date: | 10/19/2017 |
| Engineer: | | Page: | 2/4 |
| Project: | | | |
| Address: | 3710 S. Robertson Blvd, Culver City, CA 90232 | | |
| Phone: | 310-853-7180 | | |
| E-mail: | | | |

A#03-116806
CCD008
SHEET 10 OF 34

<Figure 2>

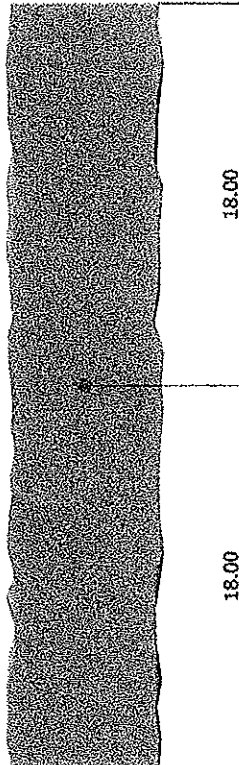

Recommended Anchor

Anchor Name: PAB Pre-Assembled Anchor Bolt - PAB5 (5/8"Ø)

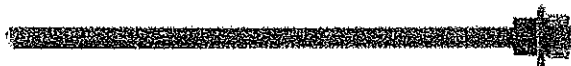



Anchor Designer™
Software
Version 2.5.6163.2

| | | | |
|-----------|---|-------|------------|
| Company: | Nishkian Chamberlain | Date: | 10/19/2017 |
| Engineer: | | Page: | 3/4 |
| Project: | | | |
| Address: | 3710 S. Robertson Blvd, Culver City, CA 90232 | | |
| Phone: | 310-853-7180 | | |
| E-mail: | | | |

3. Resulting Anchor Forces

| Anchor | Tension load, N _{ua} (lb) | Shear load x, V _{uax} (lb) | Shear load y, V _{uay} (lb) | Shear load combined, √(V _{uax}) ² + (V _{uay}) ² (lb) |
|--------|---------------------------------------|--|--|---|
| 1 | 7903.0 | 0.0 | 0.0 | 0.0 |
| Sum | 7903.0 | 0.0 | 0.0 | 0.0 |

Maximum concrete compression strain (‰): 0.00
 Maximum concrete compression stress (psi): 0
 Resultant tension force (lb): 7903
 Resultant compression force (lb): 0
 Eccentricity of resultant tension forces in x-axis, e'_{Nx} (inch): 0.00
 Eccentricity of resultant tension forces in y-axis, e'_{Ny} (inch): 0.00

A#03-116806
CCD008
SHEET 11 OF 34

4. Steel Strength of Anchor in Tension (Sec. D.5.1)

| N _{sa} (lb) | φ | φN _{sa} (lb) |
|----------------------|------|-----------------------|
| 13100 | 0.75 | 9825 |

5. Concrete Breakout Strength of Anchor in Tension (Sec. D.5.2)

$N_b = 16\lambda_a \sqrt{f_c} h_{ef}^{1.5}$ (Eq. D-7)

| λ _a | f _c (psi) | h _{ef} (in) | N _b (lb) |
|----------------|----------------------|----------------------|---------------------|
| 1.00 | 3000 | 12.000 | 55121 |

$0.75\phi N_{cb} = 0.75\phi (A_{Nc} / A_{Nco}) \Psi_{ed,N} \Psi_{c,N} \Psi_{ep,N} N_b$ (Sec. D.4.1 & Eq. D-3)

| A _{Nc} (in ²) | A _{Nco} (in ²) | c _{r,min} (in) | Ψ _{ed,N} | Ψ _{c,N} | Ψ _{ep,N} | N _b (lb) | φ | 0.75φN _{cb} (lb) |
|------------------------------------|-------------------------------------|-------------------------|-------------------|------------------|-------------------|---------------------|------|---------------------------|
| 1359.00 | 1296.00 | 18.00 | 1.000 | 1.00 | 1.000 | 55121 | 0.70 | 30345 |

6. Pullout Strength of Anchor in Tension (Sec. D.5.3)

$0.75\phi N_{pn} = 0.75\phi \Psi_{c,p} N_p = 0.75\phi \Psi_{c,p} 8A_{brg} f_c$ (Sec. D.4.1, Eq. D-13 & D-14)

| Ψ _{c,p} | A _{brg} (in ²) | f _c (psi) | φ | 0.75φN _{pn} (lb) |
|------------------|-------------------------------------|----------------------|------|---------------------------|
| 1.0 | 2.10 | 3000 | 0.70 | 26435 |



Anchor Designer™
Software
Version 2.5.6163.2

| | | | |
|-----------|---|-------|------------|
| Company: | Nishkian Chamberlain | Date: | 10/19/2017 |
| Engineer: | | Page: | 4/4 |
| Project: | | | |
| Address: | 3710 S. Robertson Blvd, Culver City, CA 90232 | | |
| Phone: | 310-853-7180 | | |
| E-mail: | | | |

A#03-116806
CCD008
SHEET 12 OF 34

11. Results

Interaction of Tensile and Shear Forces (Sec. D.7)

| Tension | Factored Load, N_{ua} (lb) | Design Strength, ϕN_n (lb) | Ratio | Status |
|-------------------|------------------------------|----------------------------------|-------|----------------|
| Steel | 7903 | 9825 | 0.80 | Pass (Governs) |
| Concrete breakout | 7903 | 30345 | 0.26 | Pass |
| Pullout | 7903 | 26435 | 0.30 | Pass |

PAB5 (5/8"Ø) with hef = 12.000 inch meets the selected design criteria.

OMEGA LEVEL LOADS NOT REQUIRED

12. Warnings

- Per designer input, the tensile component of the strength-level earthquake force applied to anchors does not exceed 20 percent of the total factored anchor tensile force associated with the same load combination. Therefore the ductility requirements of ACI 318 D.3.3.4.3 for tension need not be satisfied – designer to verify.

- Designer must exercise own judgement to determine if this design is suitable.



Anchor Designer™
Software
Version 2.5.6163.2

| | | | |
|-----------|---|-------|------------|
| Company: | Nishkian Chamberlain | Date: | 10/19/2017 |
| Engineer: | | Page: | 1/4 |
| Project: | | | |
| Address: | 3710 S. Robertson Blvd, Culver City, CA 90232 | | |
| Phone: | 310-853-7180 | | |
| E-mail: | | | |

1. Project Information

Customer company:
Customer contact name:
Customer e-mail:
Comment:

HDU8

Project description:
Location:
Fastening description:

A#03-116806
CCD008
SHEET 13 OF 34

2. Input Data & Anchor Parameters

General

Design method: ACI 318-11
Units: Imperial units

Anchor Information:

Anchor type: Cast-in-place
Material: AB
Diameter (Inch): 0.875
Effective Embedment depth, h_{ef} (Inch): 12.000
Anchor category: -
Anchor ductility: Yes
 h_{min} (Inch): 14.38
 C_{min} (Inch): 5.25
 S_{min} (Inch): 5.25

Base Material

Concrete: Normal-weight
Concrete thickness, h (Inch): 30.00
State: Cracked
Compressive strength, f_c (psi): 3000
 $\Psi_{e,v}$: 1.0
Reinforcement condition: B tension, B shear
Supplemental reinforcement: Not applicable
Reinforcement provided at corners: No
Do not evaluate concrete breakout in tension: No
Do not evaluate concrete breakout in shear: No
Ignore $6d_o$ requirement: No
Build-up grout pad: No

Load and Geometry

Load factor source: ACI 318 Section 9.2
Load combination: not set
Seismic design: Yes
Anchors subjected to sustained tension: Not applicable
Ductility section for tension: D.3.3.4.2 not applicable
Ductility section for shear: not satisfied
 Ω_o factor: not set
Apply entire shear load at front row: Yes
Anchors only resisting wind and/or seismic loads: Yes

<Figure 1>

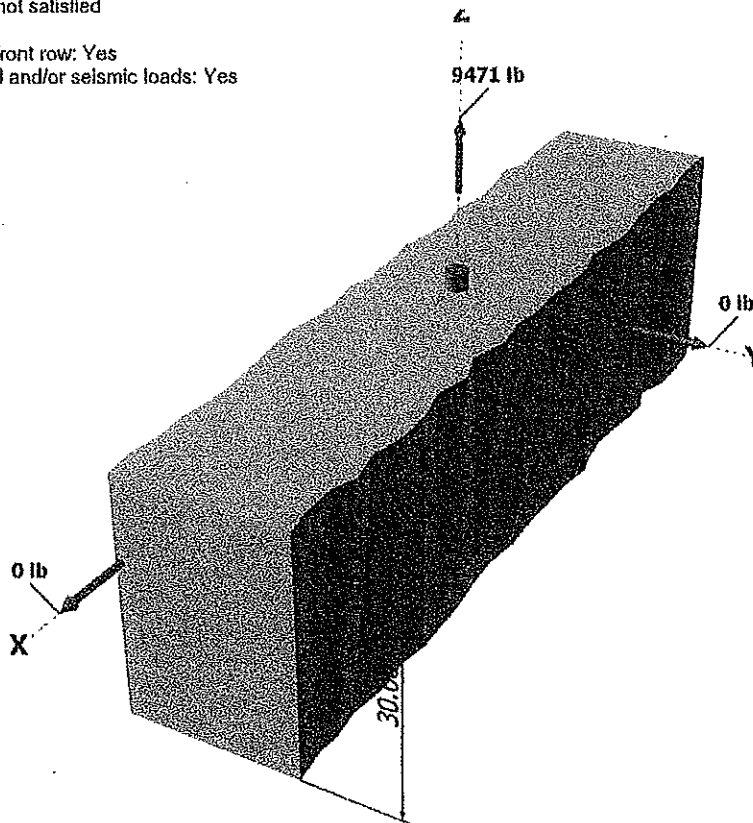



Anchor Designer™
Software
Version 2.5.6163.2

| | | | |
|-----------|---|-------|------------|
| Company: | Nishkian Chamberlain | Date: | 10/19/2017 |
| Engineer: | | Page: | 2/4 |
| Project: | | | |
| Address: | 3710 S. Robertson Blvd, Culver City, CA 90232 | | |
| Phone: | 310-853-7180 | | |
| E-mail: | | | |

<Figure 2>

A#03-116806
CCD008
SHEET 14 OF 34

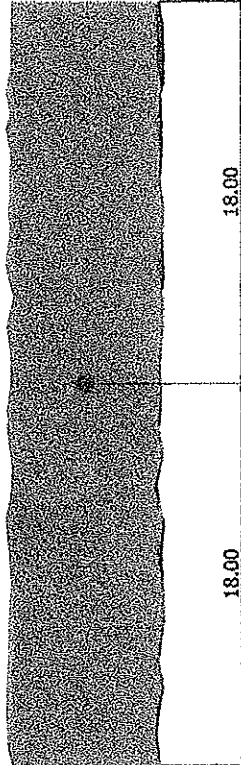

Recommended Anchor
Anchor Name: PAB Pre-Assembled Anchor Bolt - PAB7 (7/8"Ø)





Anchor Designer™
Software
Version 2.5.6163.2

| | | | |
|-----------|---|-------|------------|
| Company: | Nishkian Chamberlain | Date: | 10/19/2017 |
| Engineer: | | Page: | 3/4 |
| Project: | | | |
| Address: | 3710 S. Robertson Blvd, Culver City, CA 90232 | | |
| Phone: | 310-853-7180 | | |
| E-mail: | | | |

3. Resulting Anchor Forces

| Anchor | Tension load, N_{ud} (lb) | Shear load x, V_{ux} (lb) | Shear load y, V_{uy} (lb) | Shear load combined, $\sqrt{(V_{ux})^2 + (V_{uy})^2}$ (lb) |
|--------|--------------------------------|--------------------------------|--------------------------------|---|
| 1 | 9471.0 | 0.0 | 0.0 | 0.0 |
| Sum | 9471.0 | 0.0 | 0.0 | 0.0 |

Maximum concrete compression strain (%): 0.00
 Maximum concrete compression stress (psi): 0
 Resultant tension force (lb): 9471
 Resultant compression force (lb): 0
 Eccentricity of resultant tension forces in x-axis, e'_{tx} (inch): 0.00
 Eccentricity of resultant tension forces in y-axis, e'_{ty} (inch): 0.00

A#03-116806
CCD008
SHEET 15 OF 34

4. Steel Strength of Anchor in Tension (Sec. D.5.1)

| N_{sa} (lb) | ϕ | ϕN_{sa} (lb) |
|---------------|--------|--------------------|
| 26795 | 0.75 | 20096 |

5. Concrete Breakout Strength of Anchor in Tension (Sec. D.5.2)

$$N_b = 16\lambda_a \sqrt{f_c} h_{ef}^{1.5} \quad (\text{Eq. D-7})$$

| λ_a | f_c (psi) | h_{ef} (in) | N_b (lb) |
|-------------|-------------|---------------|------------|
| 1.00 | 3000 | 12.000 | 55121 |

$$0.75\phi N_{cb} = 0.75\phi (A_{Nc} / A_{Nco}) \psi_{od,N} \psi_{c,N} \psi_{ep,N} N_b \quad (\text{Sec. D.4.1 \& Eq. D-3})$$

| A_{Nc} (in ²) | A_{Nco} (in ²) | $c_{a,min}$ (in) | $\psi_{od,N}$ | $\psi_{c,N}$ | $\psi_{ep,N}$ | N_b (lb) | ϕ | $0.75\phi N_{cb}$ (lb) |
|-----------------------------|------------------------------|------------------|---------------|--------------|---------------|------------|--------|------------------------|
| 1383.75 | 1296.00 | 18.00 | 1.000 | 1.00 | 1.000 | 55121 | 0.70 | 30898 |

6. Pullout Strength of Anchor in Tension (Sec. D.5.3)

$$0.75\phi N_{pn} = 0.75\phi \psi_{c,P} N_p = 0.75\phi \psi_{c,P} 8A_{br} f_c \quad (\text{Sec. D.4.1, Eq. D-13 \& D-14})$$

| $\psi_{c,P}$ | A_{br} (in ²) | f_c (psi) | ϕ | $0.75\phi N_{pn}$ (lb) |
|--------------|-----------------------------|-------------|--------|------------------------|
| 1.0 | 4.07 | 3000 | 0.70 | 51219 |



Anchor Designer™
Software
Version 2.5.6163.2

| | | | |
|-----------|---|-------|------------|
| Company: | Nishkian Chamberlain | Date: | 10/19/2017 |
| Engineer: | | Page: | 4/4 |
| Project: | | | |
| Address: | 3710 S. Robertson Blvd, Culver City, CA 90232 | | |
| Phone: | 310-853-7180 | | |
| E-mail: | | | |

A#03-116806
CCD008
SHEET 16 OF 34

11. Results

Interaction of Tensile and Shear Forces (Sec. D.7)

| Tension | Factored Load, N _u (lb) | Design Strength, φN _n (lb) | Ratio | Status |
|-------------------|------------------------------------|---------------------------------------|-------|----------------|
| Steel | 9471 | 26096 | 0.47 | Pass (Governs) |
| Concrete breakout | 9471 | 30898 | 0.31 | Pass |
| Pullout | 9471 | 51219 | 0.18 | Pass |

PAB7 (7/8"Ø) with hef = 12.000 inch meets the selected design criteria.

OMEGA LEVEL LOADS NOT REQUIRED

12. Warnings

- Per designer input, the tensile component of the strength-level earthquake force applied to anchors does not exceed 20 percent of the total factored anchor tensile force associated with the same load combination. Therefore the ductility requirements of ACI 318 D.3.3.4.3 for tension need not be satisfied – designer to verify.
- Designer must exercise own judgement to determine if this design is suitable.



Anchor Designer™
Software
Version 2.5.6163.2

| | | | |
|-----------|---|-------|------------|
| Company: | Nishkian Chamberlain | Date: | 10/19/2017 |
| Engineer: | | Page: | 1/4 |
| Project: | | | |
| Address: | 3710 S. Robertson Blvd, Culver City, CA 90232 | | |
| Phone: | 310-853-7180 | | |
| E-mail: | | | |

1. Project Information

Customer company:
Customer contact name:
Customer e-mail:
Comment:

HDU11

Project description:
Location:
Fastening description:

A#03-116806
CCD008
SHEET 17 OF 34

2. Input Data & Anchor Parameters

General

Design method: ACI 318-11
Units: Imperial units

Anchor Information:

Anchor type: Cast-in-place
Material: AB
Diameter (Inch): 1.000
Effective Embedment depth, h_{ef} (Inch): 18.000
Anchor category: -
Anchor ductility: Yes
 h_{min} (Inch): 20.63
 C_{min} (Inch): 6.00
 S_{min} (Inch): 6.00

Base Material

Concrete: Normal-weight
Concrete thickness, h (Inch): 30.00
State: Cracked
Compressive strength, f'_c (psi): 3000
 $\Psi_{e,v}$: 1.0
Reinforcement condition: B tension, B shear
Supplemental reinforcement: Not applicable
Reinforcement provided at corners: No
Do not evaluate concrete breakout in tension: No
Do not evaluate concrete breakout in shear: No
Ignore ϕ requirement: No
Build-up grout pad: No

Load and Geometry

Load factor source: ACI 318 Section 9.2
Load combination: not set
Seismic design: Yes
Anchors subjected to sustained tension: Not applicable
Ductility section for tension: D.3.3.4.3 (a) 3-6 is satisfied
Ductility section for shear: not satisfied
 Ω_o factor: not set
Apply entire shear load at front row: Yes
Anchors only resisting wind and/or seismic loads: Yes

<Figure 1>

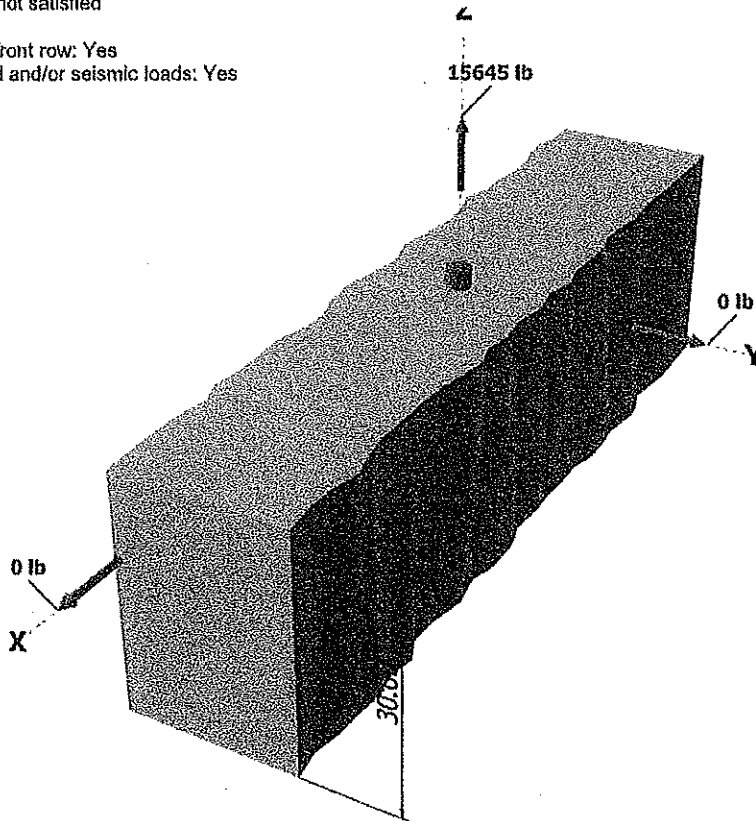

Input data and results must be checked for agreement with the existing circumstances, the standards and guidelines must be checked for plausibility.

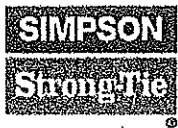

Anchor Designer™
Software
Version 2.5.6163.2

| | | | |
|-----------|---|-------|------------|
| Company: | Nishkian Chamberlain | Date: | 10/19/2017 |
| Engineer: | | Page: | 2/4 |
| Project: | | | |
| Address: | 3710 S. Robertson Blvd, Culver City, CA 90232 | | |
| Phone: | 310-853-7180 | | |
| E-mail: | | | |

<Figure 2>

A#03-116806
CCD008
SHEET 18 OF 34

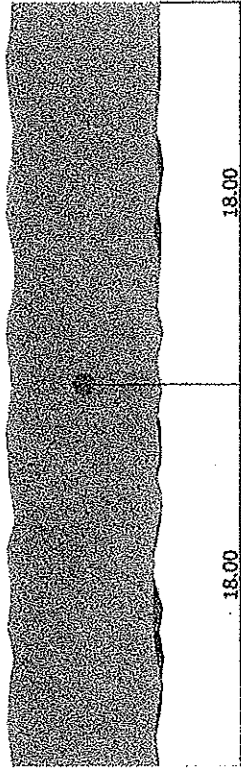

Recommended Anchor

Anchor Name: PAB Pre-Assembled Anchor Bolt - PAB8 (1"Ø)

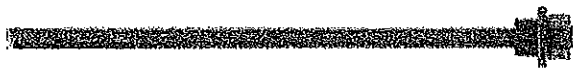



Anchor Designer™
Software
Version 2.5.6163.2

| | | | |
|-----------|---|-------|------------|
| Company: | Nishkian Chamberlain | Date: | 10/19/2017 |
| Engineer: | | Page: | 3/4 |
| Project: | | | |
| Address: | 3710 S. Robertson Blvd, Culver City, CA 90232 | | |
| Phone: | 310-853-7180 | | |
| E-mail: | | | |

3. Resulting Anchor Forces

| Anchor | Tension load, N_{sa} (lb) | Shear load x, V_{uxx} (lb) | Shear load y, V_{uyy} (lb) | Shear load combined, $\sqrt{(V_{uxx})^2 + (V_{uyy})^2}$ (lb) |
|--------|--------------------------------|---------------------------------|---------------------------------|---|
| 1 | 15645.0 | 0.0 | 0.0 | 0.0 |
| Sum | 15645.0 | 0.0 | 0.0 | 0.0 |

Maximum concrete compression strain (%): 0.00
 Maximum concrete compression stress (psi): 0
 Resultant tension force (lb): 15645
 Resultant compression force (lb): 0
 Eccentricity of resultant tension forces in x-axis, e'_{tx} (inch): 0.00
 Eccentricity of resultant tension forces in y-axis, e'_{ty} (inch): 0.00

A#03-116806
CCD008
SHEET 19 OF 34

4. Steel Strength of Anchor in Tension (Sec. D.5.1)

| N_{sa} (lb) | ϕ | ϕN_{sa} (lb) |
|---------------|--------|--------------------|
| 35150 | 0.75 | 26363 |

5. Concrete Breakout Strength of Anchor in Tension (Sec. D.5.2)

$N_b = 16\lambda_a \sqrt{f_c} h_{ef}^{1.5}$ (Eq. D-7)

| λ_a | f_c (psi) | h_{ef} (in) | N_b (lb) |
|-------------|-------------|---------------|------------|
| 1.00 | 3000 | 18.000 | 108343 |

$0.75\phi N_{cb} = 0.75\phi (A_{Nc} / A_{Nco}) \psi_{ed,N} \psi_{c,N} \psi_{cp,N} N_b$ (Sec. D.4.1 & Eq. D-3)

| A_{Nc} (in ²) | A_{Nco} (in ²) | $c_{a,min}$ (in) | $\psi_{ed,N}$ | $\psi_{c,N}$ | $\psi_{cp,N}$ | N_b (lb) | ϕ | $0.75\phi N_{cb}$ (lb) |
|-----------------------------|------------------------------|------------------|---------------|--------------|---------------|------------|--------|------------------------|
| 2043.00 | 2916.00 | 18.00 | 0.900 | 1.00 | 1.000 | 108343 | 0.70 | 35866 |

6. Pullout Strength of Anchor in Tension (Sec. D.5.3)

$0.75\phi N_{pn} = 0.75\phi \psi_{c,p} N_p = 0.75\phi \psi_{c,p} 8A_{brg} f_c$ (Sec. D.4.1, Eq. D-13 & D-14)

| $\psi_{c,p}$ | A_{brg} (in ²) | f_c (psi) | ϕ | $0.75\phi N_{pn}$ (lb) |
|--------------|------------------------------|-------------|--------|------------------------|
| 1.0 | 5.15 | 3000 | 0.70 | 64940 |



Anchor Designer™
Software
Version 2.5.6163.2

| | | | |
|-----------|---|-------|------------|
| Company: | Nishkian Chamberlain | Date: | 10/19/2017 |
| Engineer: | | Page: | 4/4 |
| Project: | | | |
| Address: | 3710 S. Robertson Blvd, Culver City, CA 90232 | | |
| Phone: | 310-853-7180 | | |
| E-mail: | | | |

A#03-116806
CCD008
SHEET 20 OF 34

11. Results

Interaction of Tensile and Shear Forces (Sec. D.7)

| Tension | Factored Load, N_u (lb) | Design Strength, ϕN_n (lb) | Ratio | Status |
|-------------------|---------------------------|----------------------------------|-------|----------------|
| Steel | 15645 | 28363 | 0.59 | Pass (Governs) |
| Concrete breakout | 15645 | 35866 | 0.44 | Pass |
| Pullout | 15645 | 64940 | 0.24 | Pass |

PAB8 (1"Ø) with hef = 18.000 inch meets the selected design criteria.

OMEGA LEVEL LOADS NOT REQUIRED

12. Warnings

- Designer must exercise own judgement to determine if this design is suitable.

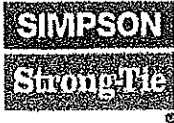

Anchor Designer™
Software
Version 2.5.6163.2

| | | | |
|-----------|---|-------|------------|
| Company: | Nishkian Chamberlain | Date: | 10/19/2017 |
| Engineer: | | Page: | 1/4 |
| Project: | | | |
| Address: | 3710 S. Robertson Blvd, Culver City, CA 90232 | | |
| Phone: | 310-853-7180 | | |
| E-mail: | | | |

1. Project Information

Customer company:
Customer contact name:
Customer e-mail:
Comment:

HDU14

Project description:
Location:
Fastening description:

**A#03-116806
CCD008
SHEET 21 OF 34**

2. Input Data & Anchor Parameters

General

Design method: ACI 318-11
Units: Imperial units

Anchor Information:

Anchor type: Cast-in-place
Material: AB
Diameter (Inch): 1.000
Effective Embedment depth, h_{ef} (Inch): 18.000
Anchor category: -
Anchor ductility: Yes
 h_{min} (Inch): 20.63
 C_{min} (Inch): 6.00
 S_{min} (Inch): 6.00

Base Material

Concrete: Normal-weight
Concrete thickness, h (Inch): 30.00
State: Cracked
Compressive strength, f'_c (psi): 3000
 Ψ_{cv} : 1.0
Reinforcement condition: B tension, B shear
Supplemental reinforcement: Not applicable
Reinforcement provided at corners: No
Do not evaluate concrete breakout in tension: No
Do not evaluate concrete breakout in shear: No
Ignore f_{do} requirement: No
Build-up grout pad: No

Load and Geometry

Load factor source: ACI 318 Section 9.2
Load combination: not set
Seismic design: Yes
Anchors subjected to sustained tension: Not applicable
Ductility section for tension: D.3.3.4.3 (a) 3-6 is satisfied
Ductility section for shear: not satisfied
 Ω_n factor: not set
Apply entire shear load at front row: Yes
Anchors only resisting wind and/or seismic loads: Yes

<Figure 1>

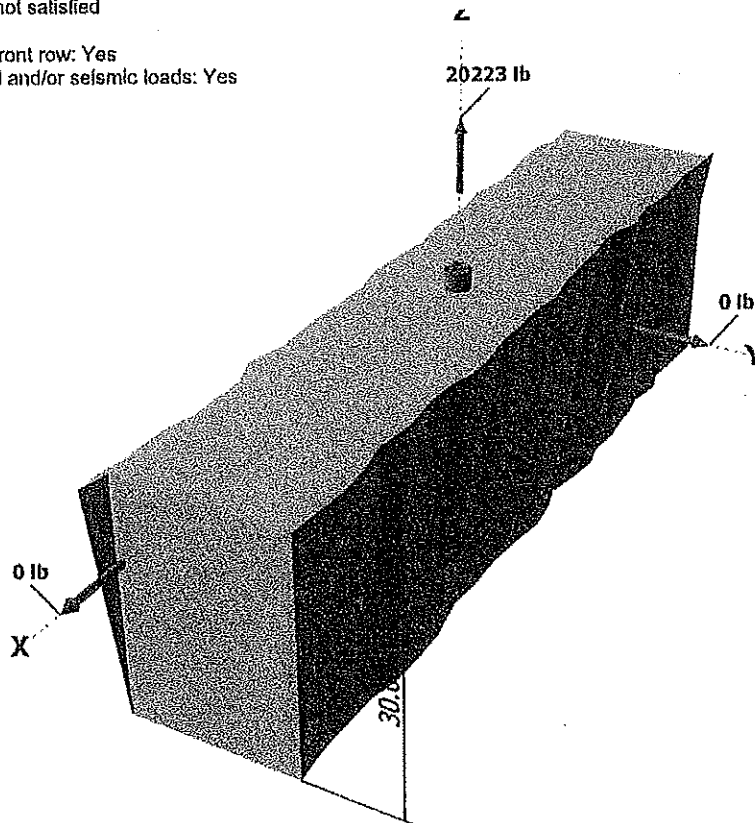

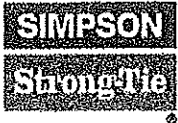

Anchor Designer™
Software
Version 2.5.6163.2

| | | | |
|-----------|---|-------|------------|
| Company: | Nishkian Chamberlain | Date: | 10/19/2017 |
| Engineer: | | Page: | 2/4 |
| Project: | | | |
| Address: | 3710 S. Robertson Blvd, Culver City, CA 90232 | | |
| Phone: | 310-853-7180 | | |
| E-mail: | | | |

<Figure 2>

A#03-116806
CCD008
SHEET 22 OF 34

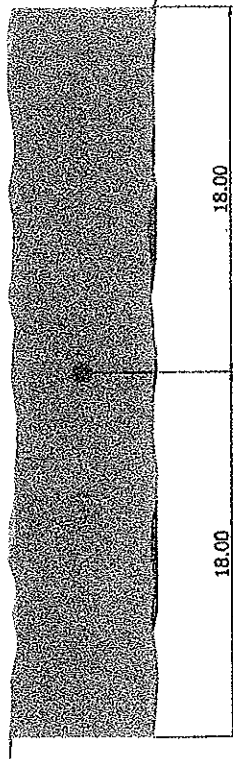

Recommended Anchor

Anchor Name: PAB Pre-Assembled Anchor Bolt - PAB8 (1"Ø)

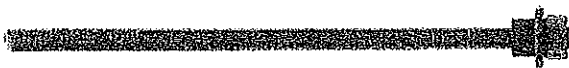



Anchor Designer™
Software
Version 2.5.6163.2

| | | | |
|-----------|---|-------|------------|
| Company: | Nishkian Chamberlain | Date: | 10/19/2017 |
| Engineer: | | Page: | 3/4 |
| Project: | | | |
| Address: | 3710 S. Robertson Blvd, Culver City, CA 90232 | | |
| Phone: | 310-853-7180 | | |
| E-mail: | | | |

3. Resulting Anchor Forces

| Anchor | Tension load, N _{un} (lb) | Shear load x, V _{unx} (lb) | Shear load y, V _{uny} (lb) | Shear load combined, $\sqrt{(V_{unx})^2 + (V_{uny})^2}$ (lb) |
|--------|---------------------------------------|--|--|---|
| 1 | 20223.0 | 0.0 | 0.0 | 0.0 |
| Sum | 20223.0 | 0.0 | 0.0 | 0.0 |

Maximum concrete compression strain (%): 0.00
 Maximum concrete compression stress (psi): 0
 Resultant tension force (lb): 20223
 Resultant compression force (lb): 0
 Eccentricity of resultant tension forces in x-axis, e'_x (inch): 0.00
 Eccentricity of resultant tension forces in y-axis, e'_y (inch): 0.00

A#03-116806
 CCD008
 SHEET 23 OF 34

4. Steel Strength of Anchor in Tension (Sec. D.5.1)

| N _{sa} (lb) | φ | φN _{sa} (lb) |
|----------------------|------|-----------------------|
| 35150 | 0.75 | 26363 |

5. Concrete Breakout Strength of Anchor in Tension (Sec. D.5.2)

$$N_b = 16\lambda_a \sqrt{f_c} h_{ef}^{1.5} \text{ (Eq. D-7)}$$

| λ _a | f _c (psi) | h _{ef} (in) | N _b (lb) |
|----------------|----------------------|----------------------|---------------------|
| 1.00 | 3000 | 18.000 | 108343 |

$$0.75\phi N_{cb} = 0.75\phi (A_{Nc} / A_{Nco}) \Psi_{ed,N} \Psi_{c,N} \Psi_{cp,N} N_b \text{ (Sec. D.4.1 \& Eq. D-3)}$$

| A _{Nc} (in ²) | A _{Nco} (in ²) | c _{a,m/b} (in) | Ψ _{ed,N} | Ψ _{c,N} | Ψ _{cp,N} | N _b (lb) | φ | 0.75φN _{cb} (lb) |
|------------------------------------|-------------------------------------|-------------------------|-------------------|------------------|-------------------|---------------------|------|---------------------------|
| 2043.00 | 2916.00 | 18.00 | 0.900 | 1.00 | 1.000 | 108343 | 0.70 | 35866 |

6. Pullout Strength of Anchor in Tension (Sec. D.5.3)

$$0.75\phi N_{pn} = 0.75\phi \Psi_{c,p} N_p = 0.75\phi \Psi_{c,p} 8 A_{brp} f_c \text{ (Sec. D.4.1, Eq. D-13 \& D-14)}$$

| Ψ _{c,p} | A _{brp} (in ²) | f _c (psi) | φ | 0.75φN _{pn} (lb) |
|------------------|-------------------------------------|----------------------|------|---------------------------|
| 1.0 | 5.15 | 3000 | 0.70 | 64940 |

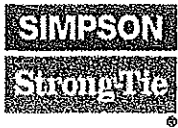

Anchor Designer™
Software
Version 2.5.6163.2

| | | | |
|-----------|---|-------|------------|
| Company: | Nishkian Chamberlain | Date: | 10/19/2017 |
| Engineer: | | Page: | 4/4 |
| Project: | | | |
| Address: | 3710 S. Robertson Blvd, Culver City, CA 90232 | | |
| Phone: | 310-853-7180 | | |
| E-mail: | | | |

A#03-116806
CCD008
SHEET 24 OF 34

11. Results

Interaction of Tensile and Shear Forces (Sec. D.7)

| Tension | Factored Load, N_{ua} (lb) | Design Strength, ϕN_n (lb) | Ratio | Status |
|-------------------|------------------------------|----------------------------------|-------|----------------|
| Steel | 20223 | 26363 | 0.77 | Pass (Governs) |
| Concrete breakout | 20223 | 35866 | 0.56 | Pass |
| Pullout | 20223 | 64940 | 0.31 | Pass |

PAB8 (1"Ø) with hef = 18.000 Inch meets the selected design criteria.

OMEGA LEVEL LOADS NOT REQUIRED

12. Warnings

- Designer must exercise own judgement to determine if this design is suitable.

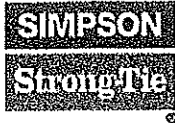

Anchor Designer™
Software
Version 2.5.6163.2

| | | | |
|-----------|---|-------|------------|
| Company: | Nishkian Chamberlain | Date: | 10/19/2017 |
| Engineer: | | Page: | 1/4 |
| Project: | | | |
| Address: | 3710 S. Robertson Blvd, Culver City, CA 90232 | | |
| Phone: | 310-853-7180 | | |
| E-mail: | | | |

1. Project Information

Customer company:
Customer contact name:
Customer e-mail:
Comment:

HD19

Project description:
Location:
Fastening description:

**A#03-116806
CCD008
SHEET 25 OF 34**

2. Input Data & Anchor Parameters

General

Design method: ACI 318-11
Units: Imperial units

Anchor Information:

Anchor type: Cast-in-place
Material: AB
Diameter (inch): 1.250
Effective Embedment depth, h_{ef} (inch): 18.000
Anchor category: -
Anchor ductility: Yes
 h_{min} (inch): 21.00
 C_{min} (inch): 7.50
 S_{min} (inch): 7.50

Base Material

Concrete: Normal-weight
Concrete thickness, h (inch): 30.00
State: Cracked
Compressive strength, f_c (psi): 3000
 Ψ_{cv} : 1.0
Reinforcement condition: B tension, B shear
Supplemental reinforcement: Not applicable
Reinforcement provided at corners: No
Do not evaluate concrete breakout in tension: Yes
Do not evaluate concrete breakout in shear: No
Ignore ϕ_{dc} requirement: No
Build-up grout pad: No

Load and Geometry

Load factor source: ACI 318 Section 9.2
Load combination: not set
Seismic design: Yes
Anchors subjected to sustained tension: Not applicable
Ductility section for tension: D.3.3.4.3 (d) is satisfied
Ductility section for shear: not satisfied
 Ω_t factor: not set
Apply entire shear load at front row: Yes
Anchors only resisting wind and/or seismic loads: Yes

<Figure 1>

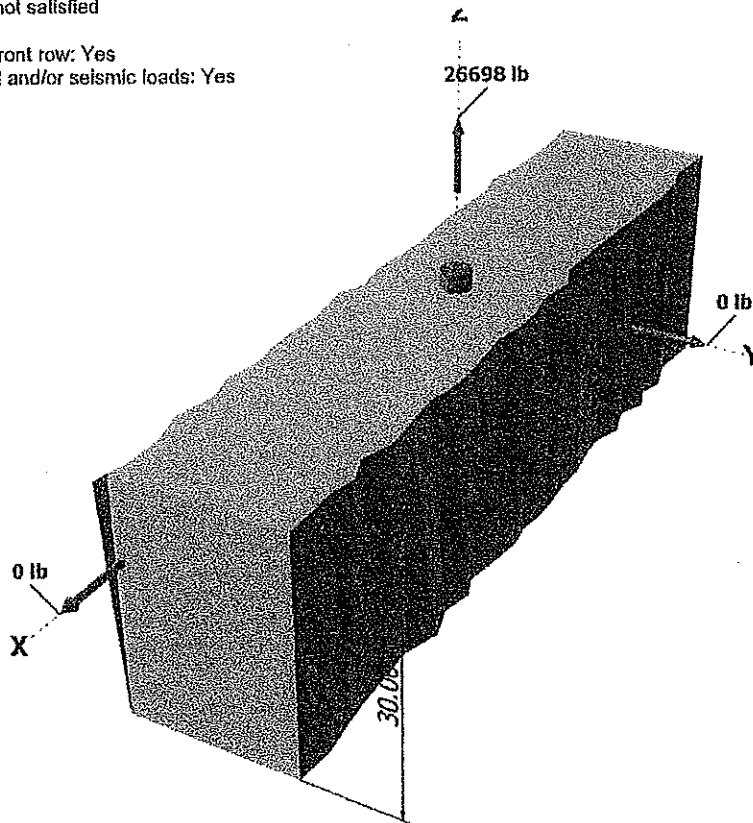

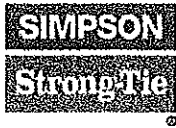

Anchor Designer™
Software
Version 2.5.6163.2

| | | | |
|-----------|---|-------|------------|
| Company: | Nishkian Chamberlain | Date: | 10/19/2017 |
| Engineer: | | Page: | 2/4 |
| Project: | | | |
| Address: | 3710 S. Robertson Blvd, Culver City, CA 90232 | | |
| Phone: | 310-853-7180 | | |
| E-mail: | | | |

<Figure 2>

A#03-116806
CCD008
SHEET 26 OF 34



Recommended Anchor
Anchor Name: PAB Pre-Assembled Anchor Bolt - PAB10 (1 1/4"Ø)

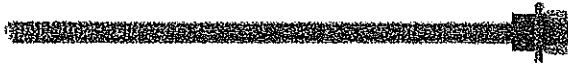



Anchor Designer™
Software
Version 2.5.6163.2

| | | | |
|-----------|---|-------|------------|
| Company: | Nishkian Chamberlain | Date: | 10/19/2017 |
| Engineer: | | Page: | 3/4 |
| Project: | | | |
| Address: | 3710 S. Robertson Blvd, Culver City, CA 90232 | | |
| Phone: | 310-853-7180 | | |
| E-mail: | | | |

3. Resulting Anchor Forces

| Anchor | Tension load, N_{ua} (lb) | Shear load x, V_{uax} (lb) | Shear load y, V_{uay} (lb) | Shear load combined, $\sqrt{(V_{uax})^2 + (V_{uay})^2}$ (lb) |
|--------|--------------------------------|---------------------------------|---------------------------------|---|
| 1 | 26698.0 | 0.0 | 0.0 | 0.0 |
| Sum | 26698.0 | 0.0 | 0.0 | 0.0 |

Maximum concrete compression strain (%): 0.00
 Maximum concrete compression stress (psi): 0
 Resultant tension force (lb): 0
 Resultant compression force (lb): 0
 Eccentricity of resultant tension forces in x-axis, e'_{Nx} (inch): 0.00
 Eccentricity of resultant tension forces in y-axis, e'_{Ny} (inch): 0.00

A#03-116806
CCD008
SHEET 27 OF 34

4. Steel Strength of Anchor in Tension (Sec. D.5.1)

| N_{sa} (lb) | ϕ | ϕN_{sa} (lb) |
|---------------|--------|--------------------|
| 56200 | 0.75 | 42150 |

6. Pullout Strength of Anchor in Tension (Sec. D.5.3)

$0.75\phi N_{pn} = 0.75\phi \psi_{c,p} N_p = 0.75\phi \psi_{c,p} 8A_{brg} f'_c$ (Sec. D.4.1, Eq. D-13 & D-14)

| $\psi_{c,p}$ | A_{brg} (in ²) | f'_c (psi) | ϕ | $0.75\phi N_{pn}$ (lb) |
|--------------|------------------------------|--------------|--------|------------------------|
| 1.0 | 8.39 | 3000 | 0.70 | 105764 |



Anchor Designer™
Software
Version 2.5.6163.2

| | | | |
|-----------|---|-------|------------|
| Company: | Nishkian Chamberlain | Date: | 10/19/2017 |
| Engineer: | | Page: | 4/4 |
| Project: | | | |
| Address: | 3710 S. Robertson Blvd, Culver City, CA 90232 | | |
| Phone: | 310-853-7180 | | |
| E-mail: | | | |

A#03-116806
CCD008
SHEET 28 OF 34

11. Results

Interaction of Tensile and Shear Forces (Sec. D.7)

| Tension | Factored Load, N_{us} (lb) | Design Strength, ϕN_n (lb) | Ratio | Status |
|---------|------------------------------|----------------------------------|-------|----------------|
| Steel | 26698 | 42150 | 0.63 | Pass (Governs) |
| Pullout | 26698 | 105764 | 0.25 | Pass |

PAB10 (1 1/4"Ø) with hef = 18.000 inch meets the selected design criteria.

OMEGA LEVEL LOADS NOT REQUIRED.
SUPPLEMENTAL REBAR REQUIRED.

12. Warnings

- Concrete breakout strength in tension has not been evaluated against applied tension load(s) per designer option. Refer to ACI 318 Section D.4.2.1 for conditions where calculations of the concrete breakout strength may not be required.
- Per designer input, ductility requirements for tension have been determined to be satisfied – designer to verify.
- Designer must exercise own judgement to determine if this design is suitable.



Anchor Designer™
Software
Version 2.5.6163.2

| | | | |
|-----------|---|-------|------------|
| Company: | Nishkian Chamberlain | Date: | 10/19/2017 |
| Engineer: | | Page: | 1/4 |
| Project: | | | |
| Address: | 3710 S. Robertson Blvd, Culver City, CA 90232 | | |
| Phone: | 310-853-7180 | | |
| E-mail: | | | |

1. Project Information

Customer company:
Customer contact name:
Customer e-mail:
Comment:

HSS5x5x1/8

Project description:
Location:
Fastening description:

A#03-116806
CCD008
SHEET 29 OF 34

2. Input Data & Anchor Parameters

General

Design method: ACI 318-11
Units: Imperial units

Anchor Information:

Anchor type: Cast-in-place
Material: AB
Diameter (inch): 0.750
Effective Embedment depth, h_{ef} (inch): 12.000
Anchor category: -
Anchor ductility: Yes
 h_{min} (inch): 14.25
 C_{min} (inch): 4.50
 S_{min} (inch): 4.50

Load and Geometry

Load factor source: ACI 318 Section 9.2
Load combination: not set
Seismic design: Yes
Anchors subjected to sustained tension: Not applicable
Ductility section for tension: D.3.3.4.3 (a) 3-6 is satisfied
Ductility section for shear: not satisfied
 Ω_a factor: not set
Apply entire shear load at front row: Yes
Anchors only resisting wind and/or seismic loads: Yes

Base Material

Concrete: Normal-weight
Concrete thickness, h (inch): 30.00
State: Cracked
Compressive strength, f'_c (psi): 3000
 Ψ_{cv} : 1.0
Reinforcement condition: B tension, B shear
Supplemental reinforcement: Not applicable
Reinforcement provided at corners: No
Do not evaluate concrete breakout in tension: Yes
Do not evaluate concrete breakout in shear: No
Ignore ϕ_{do} requirement: No
Build-up grout pad: Yes

Base Plate

Length x Width x Thickness (inch): 11.00 x 11.00 x 0.75

<Figure 1>

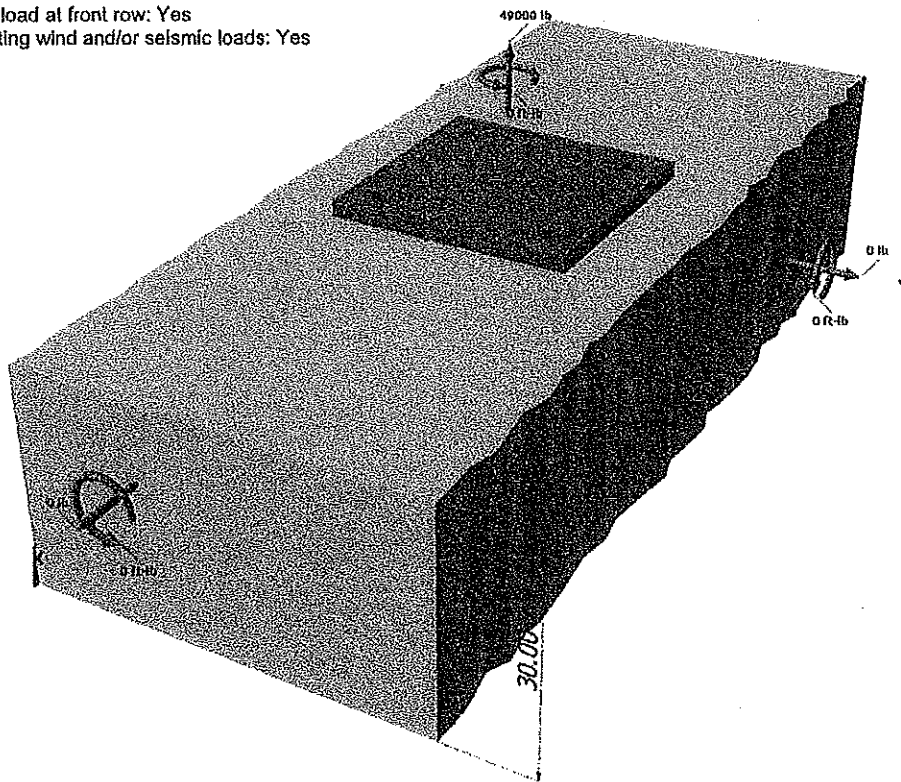

Input data and results must be checked for agreement with the existing circumstances, the standards and guidelines must be checked for plausibility.

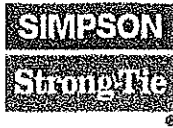

Anchor Designer™
Software
Version 2.5.6163.2

| | | | |
|-----------|---|-------|------------|
| Company: | Nishkian Chamberlain | Date: | 10/19/2017 |
| Engineer: | | Page: | 2/4 |
| Project: | | | |
| Address: | 3710 S. Robertson Blvd, Culver City, CA 90232 | | |
| Phone: | 310-853-7180 | | |
| E-mail: | | | |

<Figure 2>

A#03-116806
CCD008
SHEET 30 OF 34

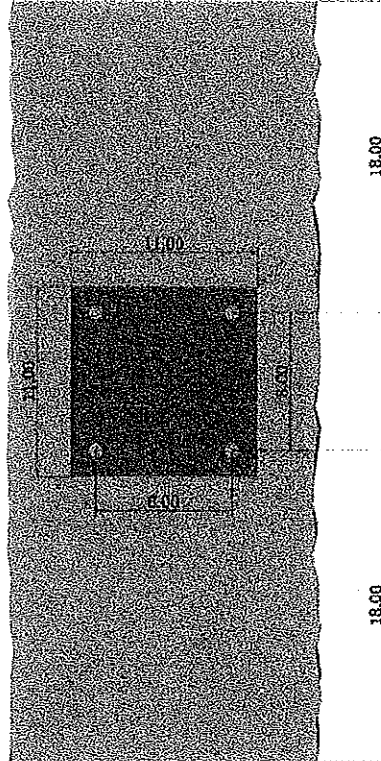

Recommended Anchor

Anchor Name: PAB Pre-Assembled Anchor Bolt - PAB6 (3/4"Ø)





Anchor Designer™
Software
Version 2.5.6163.2

| | | | |
|-----------|---|-------|------------|
| Company: | Nishkian Chamberlain | Date: | 10/19/2017 |
| Engineer: | | Page: | 3/4 |
| Project: | | | |
| Address: | 3710 S. Robertson Blvd, Culver City, CA 90232 | | |
| Phone: | 310-853-7180 | | |
| E-mail: | | | |

A#03-116806
CCD008
SHEET 31 OF 32

3. Resulting Anchor Forces

| Anchor | Tension load, N_{oa} (lb) | Shear load x, V_{oax} (lb) | Shear load y, V_{oay} (lb) | Shear load combined, $\sqrt{(V_{oax})^2 + (V_{oay})^2}$ (lb) |
|--------|--------------------------------|---------------------------------|---------------------------------|---|
| 1 | 12250.0 | 0.0 | 0.0 | 0.0 |
| 2 | 12250.0 | 0.0 | 0.0 | 0.0 |
| 3 | 12250.0 | 0.0 | 0.0 | 0.0 |
| 4 | 12250.0 | 0.0 | 0.0 | 0.0 |
| Sum | 49000.0 | 0.0 | 0.0 | 0.0 |

Maximum concrete compression strain (%): 0.00
 Maximum concrete compression stress (psi): 0
 Resultant tension force (lb): 0
 Resultant compression force (lb): 0
 Eccentricity of resultant tension forces in x-axis, e'_{Nx} (inch): 0.00
 Eccentricity of resultant tension forces in y-axis, e'_{Ny} (inch): 0.00

<Figure 3>

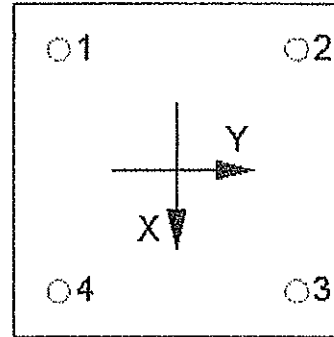

4. Steel Strength of Anchor in Tension (Sec. D.5.1)

| N_{sa} (lb) | ϕ | ϕN_{sa} (lb) |
|---------------|--------|--------------------|
| 19370 | 0.75 | 14528 |

6. Pullout Strength of Anchor in Tension (Sec. D.5.3)

$0.75\phi N_{pn} = 0.75\phi \Psi_c \rho N_p = 0.75\phi \Psi_c \rho 8 A_{brg} f'_c$ (Sec. D.4.1, Eq. D-13 & D-14)

| $\Psi_c \rho$ | A_{brg} (in ²) | f'_c (psi) | ϕ | $0.75\phi N_{pn}$ (lb) |
|---------------|------------------------------|--------------|--------|------------------------|
| 1.0 | 3.53 | 3000 | 0.70 | 44528 |



Anchor Designer™
Software
Version 2.5.6163.2

| | | | |
|-----------|---|-------|------------|
| Company: | Nishkian Chamberlain | Date: | 10/19/2017 |
| Engineer: | | Page: | 4/4 |
| Project: | | | |
| Address: | 3710 S. Robertson Blvd, Culver City, CA 90232 | | |
| Phone: | 310-853-7180 | | |
| E-mail: | | | |

A#03-116806
CCD008
SHEET 32 OF 34

11. Results

Interaction of Tensile and Shear Forces (Sec. D.7)

| Tension | Factored Load, N_{u3} (lb) | Design Strength, ϕN_n (lb) | Ratio | Status |
|---------|------------------------------|----------------------------------|-------|----------------|
| Steel | 12250 | 14528 | 0.84 | Pass (Governs) |
| Pullout | 12250 | 44528 | 0.28 | Pass |

PAB6 (3/4"Ø) with hef = 12.000 Inch meets the selected design criteria.

OMEGA LEVEL LOADS NOT REQUIRED.
SUPPLEMENTAL REBAR REQUIRED.

12. Warnings

- Concrete breakout strength in tension has not been evaluated against applied tension load(s) per designer option. Refer to ACI 318 Section D.4.2.1 for conditions where calculations of the concrete breakout strength may not be required.
- Designer must exercise own judgement to determine if this design is suitable.

TABLE 1B—ALLOWABLE TENSION LOADS AND DISPLACEMENTS FOR HDU SERIES HOLD-DOWN ASSEMBLIES^{1,2,3,4}

A#03-116806
 CCD008
 SHEET 33 OF 3

| HOLD-DOWN MODEL NO. | SDS SCREW SIZE (in) | ALLOWABLE TENSION LOADS ⁵ , P _{all} (lbs) C _D = 1.33 or C _D = 1.6 | | | | | | DISPLACEMENT Δ AT MAXIMUM LOAD ^{6,9} (in.) | |
|---------------------|---------------------|--|-------|-------|-------|------------------------|--------------------|---|----------------|
| | | Wood Member Thickness ⁸ (in.) | | | | | | Δ _{all} | Δ _s |
| | | 3 | 3.5 | 4.5 | 5.5 | 7.25 | 5.5 ⁽⁷⁾ | | |
| HDU2 | 1/4 x 1.5 | 1,810 | 1,810 | 1,810 | 1,810 | 1,810 | 1,810 | 0.069 | 0.090 |
| | 1/4 x 2.5 | 3,075 | 3,075 | 3,075 | 3,075 | 3,075 | 3,075 | 0.088 | 0.118 |
| HDU4 | 1/4 x 1.5 | 3,105 | 3,105 | 3,105 | 3,105 | 3,105 | 3,105 | 0.083 | 0.108 |
| | 1/4 x 2.5 | 4,565 | 4,565 | 4,565 | 4,565 | 4,565 | 4,565 | 0.114 | 0.154 |
| HDU5 | 1/4 x 1.5 | 3,960 | 3,960 | 3,960 | 3,960 | 3,960 | 3,960 | 0.109 | 0.142 |
| | 1/4 x 2.5 | 5,645 | 5,670 | 5,670 | 5,670 | 5,670 | 5,670 | 0.115 | 0.158 |
| HDU8 | 1/4 x 1.5 | 5,980 | 5,980 | 5,980 | 5,980 | 5,980 | 5,980 | 0.087 | 0.115 |
| | 1/4 x 2.5 | 6,765 | 6,970 | 7,870 | 7,870 | 7,870 | 7,870 | 0.113 | 0.161 |
| HDU11 | 1/4 x 2.5 | — | — | — | 9,535 | 11,175 ⁽¹⁰⁾ | 11,175 | 0.137 | 0.182 |
| HDU14 | 1/4 x 2.5 | — | — | — | — | 14,390 ⁽¹⁰⁾ | 14,445 | 0.172 | 0.239 |

For SI: 1 inch = 25.4 mm, 1 lbs = 4.45 N.

¹Tabulated allowable loads are for a hold-down assembly consisting of the hold-down device attached to a wood structural member with the size of SDS wood screws noted in the table. The quantity of SDS wood screws must comply with Table 1A.

²The allowable loads for the hold-down assemblies are based on allowable stress design (ASD) and include the load duration factor, C_D, corresponding with wind/earthquake loading in accordance with the NDS. No further increase is allowed.

³When using the basic load combinations in accordance with IBC Section 1605.3.1, the tabulated allowable loads for the hold-down assembly must not be increased for wind or earthquake loading. When using the alternative basic load combinations in IBC Section 1605.3.2 that include wind or earthquake loads that tabulated allowable loads for the hold-down assembly must not be increased by 33 1/3 percent, nor can the alternative basic load combinations be reduced by a factor of 0.75.

⁴Anchorage to concrete or masonry must be determined in accordance with Section 4.1.3 of this report.

⁵The tabulated allowable (ASD) tension loads must be multiplied by 1.4 to obtain the strength-level resistance loads associated with the tabulated Δ_s deformations.

⁶The minimum thickness of the wood members (i.e., the dimension parallel to the long axis of the SDS wood screws) must be as indicated in the table above. The minimum width of the wood members must be 3 1/2 inches, except as noted.

⁷The minimum width of the wood members must be 5 1/2 inches (6x6 nominal).

⁸Tabulated displacement values, Δ_{all} and Δ_s, for hold-down assemblies include all sources of hold-down assembly elongation, such as fastener slip, hold-down device extension and rotation, and anchor rod elongation, at ASD-level and strength-level forces, respectively.

⁹Elongation of the hold-down anchor rod must be calculated when the ASTM steel specification of the anchor rod differs from that described in the Section 3.2.4 of this report, or the actual unbraced length is greater than 6 inches. In lieu of calculating the elongation of the hold-down anchor rod for hold-downs raised 6 inches to 18 inches above the concrete, an additional 0.010 inch may be added to the tabulated hold-down displacement at allowable load, Δ_{all}, and an additional 0.014 inch may be added to the tabulated hold-down displacement at strength-level load, Δ_s, to account for anchor rod elongation.

¹⁰Requires a heavy hex anchor nut to achieve tabulated tension loads.

TABLE 1C—ALLOWABLE TENSION LOADS AND DISPLACEMENTS OF HDU SERIES HOLD-DOWN CONNECTORS^{1,2,3}

| HOLD-DOWN MODEL NO. | ALLOWABLE TENSION LOAD, P _{all} (lbs) | DISPLACEMENT Δ AT MAX LOAD ⁴ (in.) | |
|---------------------|--|---|----------------|
| | | Δ _{all} | Δ _s |
| HDU2 | 3,505 | 0.081 | 0.110 |
| HDU4 | 4,990 | 0.089 | 0.117 |
| HDU5 | 5,670 | 0.078 | 0.107 |
| HDU8 | 9,950 | 0.131 | 0.164 |
| HDU11 | 11,905 | 0.121 | 0.157 |
| HDU14 | 15,905 ⁽⁵⁾ | 0.124 | 0.172 |

For SI: 1 inch = 25.4 mm, 1 lbs = 4.45 N.

¹This table lists the allowable tensile strength of the steel hold-down connectors exclusive of fasteners and anchor rods when tested on a steel jig.

²Allowable tension loads are applicable for designs complying with Section 12.11.2.2.2 of ASCE 7.

³When using the basic load combinations in accordance with IBC Section 1605.3.1, the tabulated allowable loads for the hold-down must not be increased for wind or earthquake loading. When using the alternative basic load combinations in IBC Section 1605.3.2 that include wind or earthquake loads that tabulated allowable loads for the hold-down must not be increased by 33 1/3 percent, nor can the alternative basic load combinations be reduced by a factor of 0.75.

⁴Δ_{all} is the displacement at the tabulated ASD load and Δ_s is displacement at the strength-level load. Tabulated displacement values in Table 1C consist only of deformation of the hold-down (tie-down) device when tested on a steel jig. Other variables contributing to total displacement, Δ_{all}, such as fastener slip, wood shrinkage, and anchor bolt/rod elongation, must be checked by the registered design professional. The tabulated allowable (ASD) tension loads must be multiplied by 1.4 to obtain the strength-level loads associated with the tabulated strength-level deformations, Δ_s.

⁵Requires a heavy hex anchor nut to achieve tabulated tension loads.



A#03-116806
 CCD008
 SHEET 34 OF 34

TABLE 1 — ALLOWABLE TENSION LOADS AND DISPLACEMENTS FOR HDA AND HD BOLT HOLD-DOWN ASSEMBLIES^{1,2,3}

| MODEL NO. | DIMENSIONS (in.) | | | | | | | FASTENERS | | | MINIMUM WOOD MEMBER THK ¹⁰ (in.) | ALLOWABLE TENSION LOADS ⁴ , P _{all} (lbs) C _D =1.6 | DISPLACEMENT ^{5,6} Δ, (in.) | |
|-------------------|--------------------------------|-------------------------------|-------------------------------|---------------------------------|--------------------------------|-------------------------------|--------------------------------|-------------------------------|-----------------------------|------------|---|---|--------------------------------------|----------------|
| | HB ⁹ | SB | W | H | B | SO | CL | ANCHOR BOLT DIA. (in.) | WOOD MBR BOLTS ⁸ | | | | Δ _{all} | Δ _s |
| | | | | | | | | | QTY. | DIA. (in.) | | | | |
| HD2A | 4 ⁹ / ₁₆ | 2 ¹ / ₂ | 2 ¹ / ₂ | 8 | 2 ⁹ / ₁₆ | 3 | 1 ⁷ / ₁₆ | 3 | 2 | 3 | 1 ¹ / ₂ | 1,900 | 0.142 | 0.195 |
| | | | | | | | | | | | 2 ¹ / ₂ | 2455 | 0.146 | 0.207 |
| | | | | | | | | | | | 3 | 2455 | 0.158 | 0.223 |
| | | | | | | | | | | | 3 ¹ / ₂ | 2475 | 0.151 | 0.219 |
| HD5 | 5 ¹ / ₂ | 3 | 2 ¹ / ₂ | 6 ³ / ₄ | 3 ¹ / ₂ | 3 ³ / ₄ | 2 ¹ / ₂ | 3 | 2 | 3 | 1 ¹ / ₂ | 2,405 | 0.153 | 0.198 |
| | | | | | | | | | | | 2 ¹ / ₂ | 3,835 | 0.153 | 0.197 |
| | | | | | | | | | | | 3 | 4,055 | 0.178 | 0.250 |
| | | | | | | | | | | | 3 ¹ / ₂ | 4,875 | 0.157 | 0.250 |
| HD7 | 6 ³ / ₄ | 3 ¹ / ₂ | 3 ¹ / ₂ | 11 ¹ / ₄ | 3 ³ / ₄ | 2 ¹ / ₂ | 2 ¹ / ₂ | 1 ¹ / ₂ | 3 | 3 | 4 ¹ / ₂ | 5,010 | 0.159 | 0.234 |
| | | | | | | | | | | | 3 | 6,600 | 0.151 | 0.200 |
| | | | | | | | | | | | 3 ¹ / ₂ | 6,600 | 0.098 | 0.149 |
| | | | | | | | | | | | 4 ¹ / ₂ | 6,600 | 0.103 | 0.144 |
| HD9 | 7 | 4 | 3 ¹ / ₂ | 16 ¹ / ₂ | 4 ⁷ / ₁₆ | 3 ³ / ₄ | 2 ¹ / ₂ | 1 ¹ / ₂ | 3 | 1 | 5 ¹ / ₂ | 6,600 | 0.112 | 0.157 |
| | | | | | | | | | | | 3 | 8,810 | 0.159 | 0.192 |
| | | | | | | | | | | | 3 ¹ / ₂ | 10,330 | 0.143 | 0.179 |
| | | | | | | | | | | | 4 ¹ / ₂ | 12,185 | 0.154 | 0.215 |
| HD12 ⁷ | 7 | 4 | 3 ¹ / ₂ | 20 ⁵ / ₁₆ | 4 ⁷ / ₁₆ | 3 ³ / ₄ | 2 ¹ / ₂ | 1 | 4 | 1 | 5 ¹ / ₂ | 12,185 | 0.108 | 0.162 |
| | | | | | | | | | | | 3 ¹ / ₂ | 11,775 | 0.171 | 0.244 |
| | | | | | | | | | | | 4 ¹ / ₂ | 13,335 | 0.177 | 0.250 |
| | | | | | | | | | | | 5 ¹ / ₂ ¹¹ | 14,295 | 0.184 | 0.250 |
| HD19 ⁷ | 7 | 4 | 3 ¹ / ₂ | 24 ¹ / ₂ | 4 ⁷ / ₁₆ | 3 ³ / ₄ | 2 ¹ / ₂ | 1 ¹ / ₂ | 5 | 1 | 4 ¹ / ₂ | 14,475 | 0.192 | 0.250 |
| | | | | | | | | | | | 7 ¹ / ₄ | 15,435 | 0.194 | 0.250 |
| | | | | | | | | | | | 5 ¹ / ₂ ¹¹ | 16,510 | 0.162 | 0.227 |
| | | | | | | | | | | | 7 ¹ / ₄ | 16,735 | 0.191 | 0.250 |
| HD19 ⁷ | 7 | 4 | 3 ¹ / ₂ | 24 ¹ / ₂ | 4 ⁷ / ₁₆ | 3 ³ / ₄ | 2 ¹ / ₂ | 1 ¹ / ₂ | 5 | 1 | 5 ¹ / ₂ ¹¹ | 16,775 | 0.200 | 0.250 |
| | | | | | | | | | | | 7 ¹ / ₄ | 19,360 | 0.180 | 0.249 |
| | | | | | | | | | | | 5 ¹ / ₂ ¹¹ | 18,550 | 0.133 | 0.198 |
| | | | | | | | | | | | 5 ¹ / ₂ ¹² | 19,070 | 0.137 | 0.207 |

SI: 1 inch = 25.4 mm, 1 lbs = 4.45 N.

1. Tabulated allowable loads are for a hold-down assembly consisting of the hold-down device attached to a wood structural member(s) with the fasteners as specified in this table (Table 1).
2. Allowable loads for the hold-down assemblies are based on allowable stress design (ASD) and include the load duration factor, C_D = 1.6, corresponding with wind/earthquake loading in accordance with the NDS. No further increase is allowed. The tabulated values shall be reduced where other load durations govern.
3. Anchorage to concrete or masonry shall be determined in accordance with Section 4.1.3 of this report. Anchorage to concrete or masonry walls shall be in accordance with Section 4.1.2 of this report.
4. Tabulated allowable (ASD) tension loads shall be multiplied by 1.4 to obtain the strength-level resistance loads related with the tabulated Δ_s deformations.
5. Tabulated displacement values, Δ_{all} and Δ_s, for hold-down assemblies include all sources of hold-down assembly elongation, such as hold-down device extension and rotation fastener slip, and anchor rod elongation, at ASD-level and strength level forces respectively.
6. Elongation of the hold-down anchor rod shall be calculated when the actual unbraced length is greater than 6 inches for the HD2A hold-down, or greater than 8 inches for the HD series hold-downs, or the ASTM steel specification of the anchor rod differs from that described in the Section 3.2.4 of



CHANGE ORDER REQUEST

Project: Marshall Elementary - New 6-8 Classroom Bldg.

COR No. 15 R0

Date: 3/22/2018

DESCRIPTION OF WORK

Additional Rebar for CCD 11 and 12

SUMMARY OF COSTS

| Item Description | Company | Amount Requested |
|--|----------------|------------------|
| Subcontract Costs | | |
| Labor installing Horizontels for work out of sequence on ccd 11 & 12 | Vista Steel Co | 1,511 |
| Rebar for CCD 11 and 12 | Vista Steel Co | 1,544 |
| | Subtotal: | 3,055 |
| Total Change Order Request Amount | | 3,055 |

APPROVAL

(Please note that if this Change Order Request is not approved by , additional costs and schedule impacts may result)

Oxnard School District

Bernards Bros. Inc.

Signature

Signature

Printed Name & Title

Printed Name & Title

Date

Date

*Jennifer MacLean
CFW Program Mgr.*



CHANGE ORDER REQUEST

COR No. 15 R0

Date: 3/22/2018

Project: Marshall Elementary - New 6-8 Classroom Bldg.

DESCRIPTION OF WORK

Additional Rebar for CCD 11 and 12

SUMMARY OF COSTS

| Item Description | Company | Amount Requested |
|--|----------------|------------------|
| Subcontract Costs | | |
| Labor installing Horizontels for work out of sequence on ccd 11 & 12 | Vista Steel Co | 1,511 |
| Rebar for CCD 11 and 12 | Vista Steel Co | 1,544 |
| | Subtotal: | 3,055 |
| Total Change Order Request Amount | | 3,055 |

APPROVAL

(Please note that if this Change Order Request is not approved by , additional costs and schedule impacts may result)

Oxnard School District

Bernards Bros. Inc.

Signature

Signature

Printed Name & Title

Printed Name & Title

Date

Date

VISTA Steel Company

January 29, 2018

BERNARDS BUILDERS MGT
555 FIRST STREET
SAN FERNANDO, CA 91340

Project: MARSHALL NEW CLASSROOM

Re: **VT1804**
CC#9

Gentlemen,

Following is the description and breakdown for the above referenced additional charge:

**CC# 9 Labor for putting Horizontels @ the request of Contractor
CCD #11 and CCD #12**

| | QTY | UOM | |
|---------------------|-----|------|---------------------|
| Fabricated material | | LBS | \$ - |
| Detailing | | HRS | \$ - |
| Cartage | | HRS | \$ - |
| Installation | 16 | HRS | \$ 1,313.92 |
| Subsistance | 0 | DAYS | \$ - |
| Accessories | | LS | \$ - |
| SUBTOTAL | | | \$ 1,313.92 |
| Overhead 15% | | | \$ 197.09 |
| SUBTOTAL | | | \$ 1,511.01 |
| Profit | | | \$ - |
| TOTAL | | | \$ 1,511 |

This change will appear and become due with your next invoice. If this change is the responsibility of the owner we request that you process it immediately.

Respectfully submitted,

VISTA Steel Company

Iqbal Toor

Iqbal Toor
Contract Administrator

VISTA Steel Company

331 West Lewis
Ventura, California 93001
(805) 653-1189

CONTRACT CHANGE # CCO#4
 MISCELLANEOUS RECORDS
JOB NUMBER 171909

CONTRACT CHANGE:

WE HEREBY AUTHORIZE VISTA STEEL COMPANY TO PERFORM THE FOLLOWING WORK ON THE JOBSITE AS DESCRIBED BELOW AND AGREE TO ACCEPT REASONABLE CHARGES FOR THE WORK PERFORMED:

DESCRIPTION OF WORK:

Putting in horizontals at the Request of Contractor at all Step location CCO#11 and CCO#12 Contractor Labor Only For the Completion of Slab on Grade Due to Electrician and Plumber Not being Ready

IMMEDIATE LABOR AND/OR MATERIALS FURNISHED:

| | REGULAR | FULL/PREMIUM | |
|------------------|--------------------------|----------------|--------------------------|
| SUPERVISOR | _____ HRS. | _____ HRS. | _____ |
| FOREMAN | _____ HRS. | _____ HRS. | _____ |
| JOURNEYMAN | <u>16</u> HRS. | _____ HRS. | _____ |
| OTHER | _____ HRS. | _____ HRS. | _____ |
| WORK IN PROGRESS | <input type="checkbox"/> | WORK COMPLETED | <input type="checkbox"/> |

MISCELLANEOUS RECORDS:

THE UNDERSIGNED AGREES THAT THE HEREINAFTER DESCRIBED CIRCUMSTANCES AND/OR FACTS ARE CORRECT AND ASSUMES FULL RESPONSIBILITY FOR ANY FUTURE DEVELOPMENT WHICH COULD ORIGINATE ON THEM:

Marshall New Classroom
PROJECT

Bennards Builders
CONTRACTOR

Oxnard
LOCATION

[Signature]
PRINT

1-26-18
DATE

[Signature]
BY

Martie Rios
VISTA'S REPRESENTATIVE

[Signature]
SIGN

VISTA Steel Company

January 4, 2018

BERNARDS BUILDERS MGT
555 FIRST STREET
SAN FERNANDO, CA 91340

Project: MARSHALL NEW CLASSROOM

Re: **VT1804**
CC#7

Gentlemen,

Following is the description and breakdown for the above referenced additional charge:

CC# 7 Place iron for Slab on Grade at power boxes & at pour breaks at the request of contractor

| | QTY | UOM | | |
|---------------------|------|------|-----------|--------------|
| Fabricated material | 453 | LBS | \$ | 330.69 |
| Detailing | 0.00 | HRS | \$ | - |
| Cartage | 0.50 | HRS | \$ | 42.50 |
| Installation | 12 | HRS | \$ | 969.84 |
| Subsistance | 0 | DAYS | \$ | - |
| Accessories | | LS | \$ | - |
| SUBTOTAL | | | \$ | 1,343.03 |
| Overhead 15% | | | \$ | 201.45 |
| SUBTOTAL | | | \$ | 1,544.48 |
| Profit | | | \$ | - |
| TOTAL | | | \$ | 1,544 |

This change will appear and become due with your next invoice. If this change is the responsibility of the owner we request that you process it immediately.

Respectfully submitted,

VISTA Steel Company

Iqbal Toor

Iqbal Toor
Contract Administrator

VISTA Steel Company

331 West Lewis
Ventura, California 93001
(805) 653-1189

CONTRACT CHANGE # CP#7
 MISCELLANEOUS RECORDS
 JOB NUMBER VH1804

CONTRACT CHANGE:

WE HEREBY AUTHORIZE VISTA STEEL COMPANY TO PERFORM THE FOLLOWING WORK ON THE JOBSITE AS DESCRIBED BELOW AND AGREE TO ACCEPT REASONABLE CHARGES FOR THE WORK PERFORMED:

DESCRIPTION OF WORK:

Place Iron For Slab on Grad At power Boxes
and At Power breaks At the Request of Contractor
CP#7 3lbs for Flatwork
3lbs for CLD #11 & #12 Const. Joints

IMMEDIATE LABOR AND/OR MATERIALS FURNISHED:

| | REGULAR | FULL/PREMIUM | |
|------------|---------------|--------------|-------|
| SUPERVISOR | _____ HRS. | _____ HRS. | _____ |
| FOREMAN | <u>6</u> HRS. | _____ HRS. | _____ |
| JOURNEYMAN | <u>6</u> HRS. | _____ HRS. | _____ |
| OTHER | _____ HRS. | _____ HRS. | _____ |

WORK IN PROGRESS WORK COMPLETED

MISCELLANEOUS RECORDS:

THE UNDERSIGNED AGREES THAT THE HEREINAFTER DESCRIBED CIRCUMSTANCES AND/OR FACTS ARE CORRECT AND ASSUMES FULL RESPONSIBILITY FOR ANY FUTURE DEVELOPMENT WHICH COULD ORIGINATE ON THEM:

Marshall New Classroom
 PROJECT
Ormond
 LOCATION
14/18
 DATE
 VISTA'S REPRESENTATIVE

Bernards Builders
 CONTRACTOR
Will Van Zee
 PRINT
Will Van Zee
 BY
06-04-18
 SIGN

APPLICATION FOR APPROVAL OF CONSTRUCTION CHANGE DOCUMENT - CCD CATEGORY A/B

This application is for construction changes, as defined in IR A-6, to approved contract documents. This form shall be completed by the Design Professional in General Responsible Charge of the project, in accordance with California Code of Regulations, Title 24, Part 1, Section 4-338 (c) and in compliance with DSA IR A-6.

| | |
|--|-------------------------|
| School District/Owner: Oxnard School District | DSA File #: 56 - 22 |
| Project Name/School: Marshall Elementary School New Classroom Building | DSA App. #: 03 - 116806 |

| APPLICANT | | |
|---|------------------------------|---|
| CCD Cat. <input checked="" type="checkbox"/> A / <input type="checkbox"/> B, #011 | Date Submitted: 12/13/17 | Attached Pages?: <input type="checkbox"/> No <input type="checkbox"/> Yes (4 pages) |
| For CCD Cat. B, this is a <input type="checkbox"/> voluntary submittal, <input type="checkbox"/> DSA required submittal (attach DSA notification requiring submission). | | |
| Firm Name: CSDA Design Group | Contact Name: Michael Schoen | |
| Email: mschoen@csdadesigngroup.com | Phone Number: (310) 301-4772 | |
| Address: 889 N Douglas St, Suite 100 | | |
| City: El Segundo | State: CA | Zip: 90245 |
| <input type="checkbox"/> A DSA 301-N, DSA 301-P, or 90-Day Letter has been issued for this project. | | |
| <input checked="" type="checkbox"/> For project currently under construction. | | |
| <input type="checkbox"/> To obtain DSA approval of existing uncertified building(s). | | |

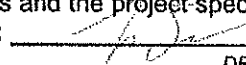
| DESIGN PROFESSIONAL IN GENERAL RESPONSIBLE CHARGE | |
|---|-----------------------|
| Name of Design Professional in General Responsible Charge: Michael Schoen | |
| Professional License #: C-35165 | Discipline: Architect |
| Design Professional in General Responsible Charge Statement: The attached Construction Change Documents have been examined by me for design intent and appear to meet the appropriate requirements of Title 24, California Code of Regulations and the project specifications. They are acceptable for incorporation into the construction of the project. | |
| Signature:  | |
| DESIGN PROFESSIONAL IN GENERAL RESPONSIBLE CHARGE | |

| |
|--|
| CHECK THIS BOX: <input checked="" type="checkbox"/> To confirm that all CCD drawings and, when applicable, first sheet or index of calculations and specifications have been stamped and signed by the Responsible Design Professional listed on DSA 1 for this project. |
| Brief description of construction change (attach additional sheets if needed): (12) electrical conduits with sleeves varying from 1"-4" dia. penetrating through the concrete stem wall of footing to the electrical room 106. New details attached with reference drawings. For clarification we have provided a BIM model images showing impacted areas. |
| List of DSA approved drawings affected by this CCD: S-211, S-400A |

| DSA USE ONLY | DSA Stamp |
|--|--|
| SSS _____ Date _____ Approved / Disapproved / Not Req'd FLS _____ Date _____ Approved / Disapproved <u>Not Req'd</u> ACS _____ Date _____ Approved / Disapproved <u>Not Req'd</u> Remarks _____ |  APPROVED DIV. OF THE STATE ARCHITECT LOS ANGELES REGIONAL OFFICE DATE 01/05/2018 eyoshimu |

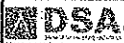

APPROVED

DIV. OF THE STATE ARCHITECT
LOS ANGELES REGIONAL OFFICE

DATE 01/05/2018

eyoshimu

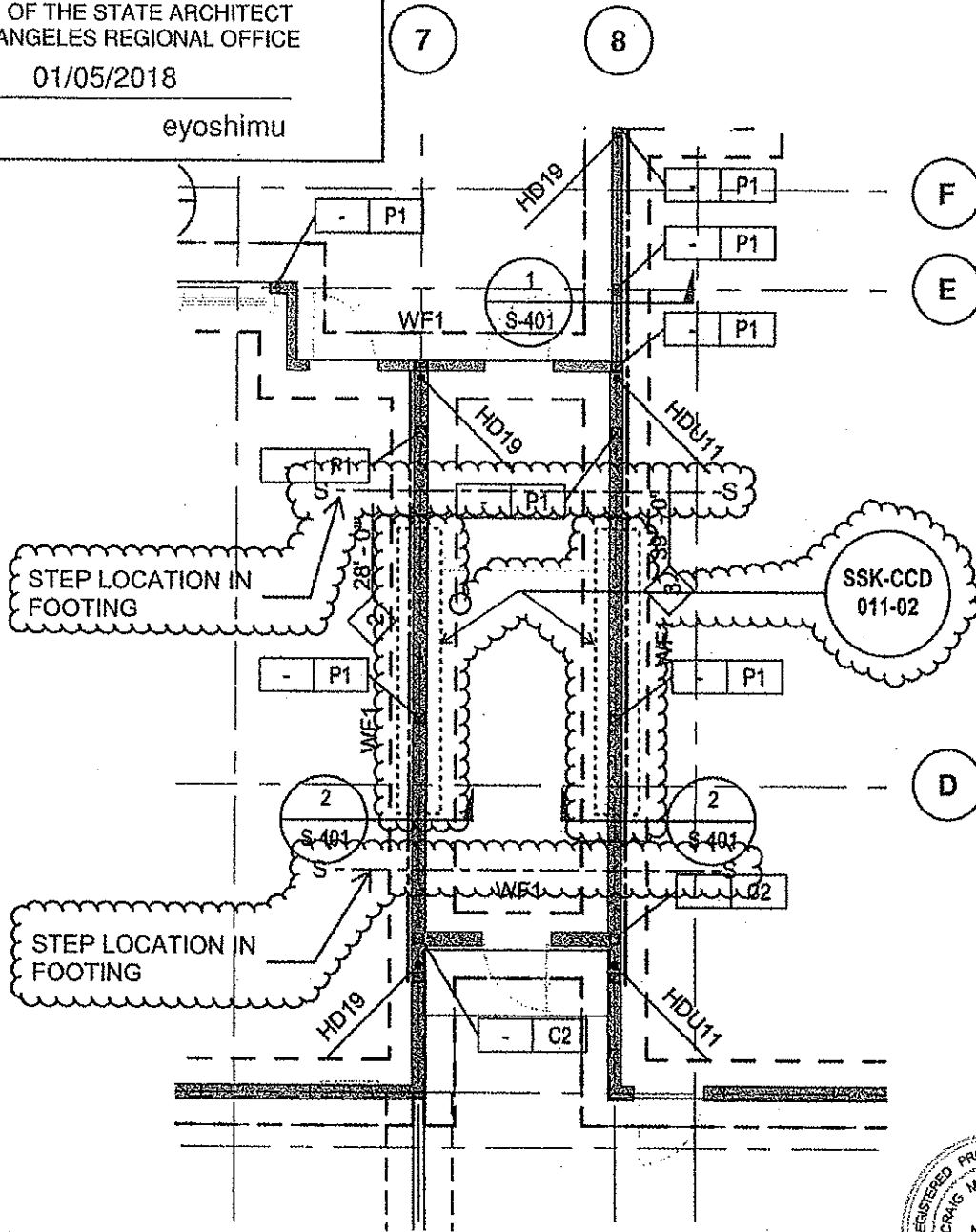

REVISED PARTIAL PLAN

Description of change:

Partial plan to denote location where new detail is to be applied. New detail provides additional reinforcement at area with multiple pipe penetrations (12 total) through stem wall of footing.
referenced drawings/details: 1/S-400A, S-211

**NISHKIAN
CHAMBERLAIN**
CONSULTING AND STRUCTURAL
ENGINEERS SINCE 1919
NC PROJECT #: 40340

CSDA PROJECT #: 1534.01
MARSHALL ES - NEW CLASSROOM
BUILDING
2900 Thurgood Marshall Dr, Oxnard, CA 93036

SHEET: 1 OF 2
DRAWING REFERENCE: S-211
SCALE: NTS
DATE: 12/08/2017

CSDA DESIGN GROUP

DSA A# 03-116806

REVISED PLAN

CCD #011

SSK-CCD011-01

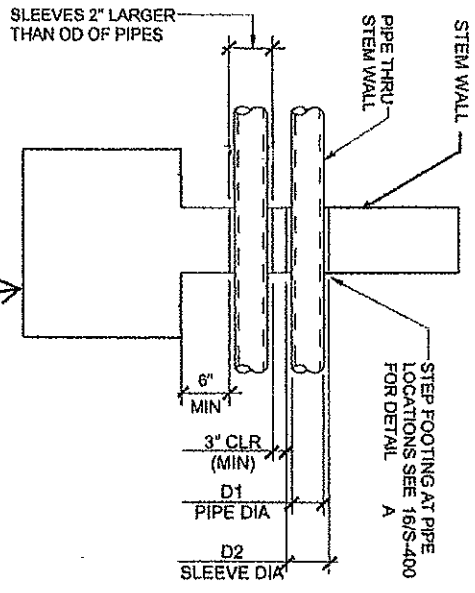

A SECTION

PIPES WITH SLEEVE BY OTHERS (12 PIPES TOTAL)

- 1 - 1" DIA PIPE W/ 3/1/2" SLEEVE
- 2 - 2" DIA PIPE W/ 4-1/2" SLEEVE
- 3 - 3" DIA PIPE W/ 5-1/2" SLEEVE
- 4 - 4" DIA PIPE W/ 6-1/2" SLEEVE

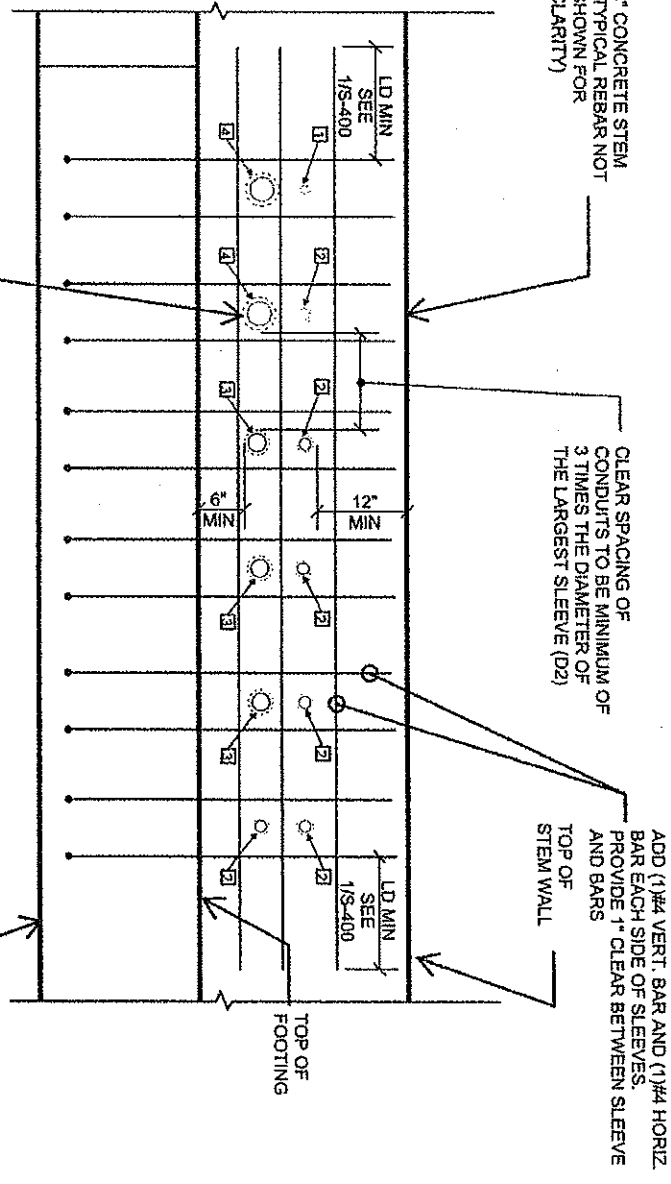

B ELEVATION

NEW DETAIL

Description of change:
 New detail provides additional reinforcement at area with multiple pipe penetrations (12 total) through stem wall of footing.
 referenced drawings/details: 1/S-400A, S-211

CSDA PROJECT # 1534.01
 MARSHALL ES - NEW CLASSROOM BUILDING
 2900 Thurgood Marshall Dr, Oxnard, CA 93036
DSA A# 03-116806

SHEET: 2 OF 2
 DRAWING REFERENCE: 1/S-400A NTS
 SCALE: DATE: 12/08/2017
NEW DETAIL

DSA APPROVED
 DIV. OF THE STATE ARCHITECT
 LOS ANGELES REGIONAL OFFICE
 DATE 01/05/2018
 eyoshimu



NISHKIAN CHAMBERLAIN
 CONSULTING AND STRUCTURAL ENGINEERS SINCE 1919
 NC PROJECT #: 40340
CCD # 011

CSDA DESIGN GROUP
SSK-CCD011-02

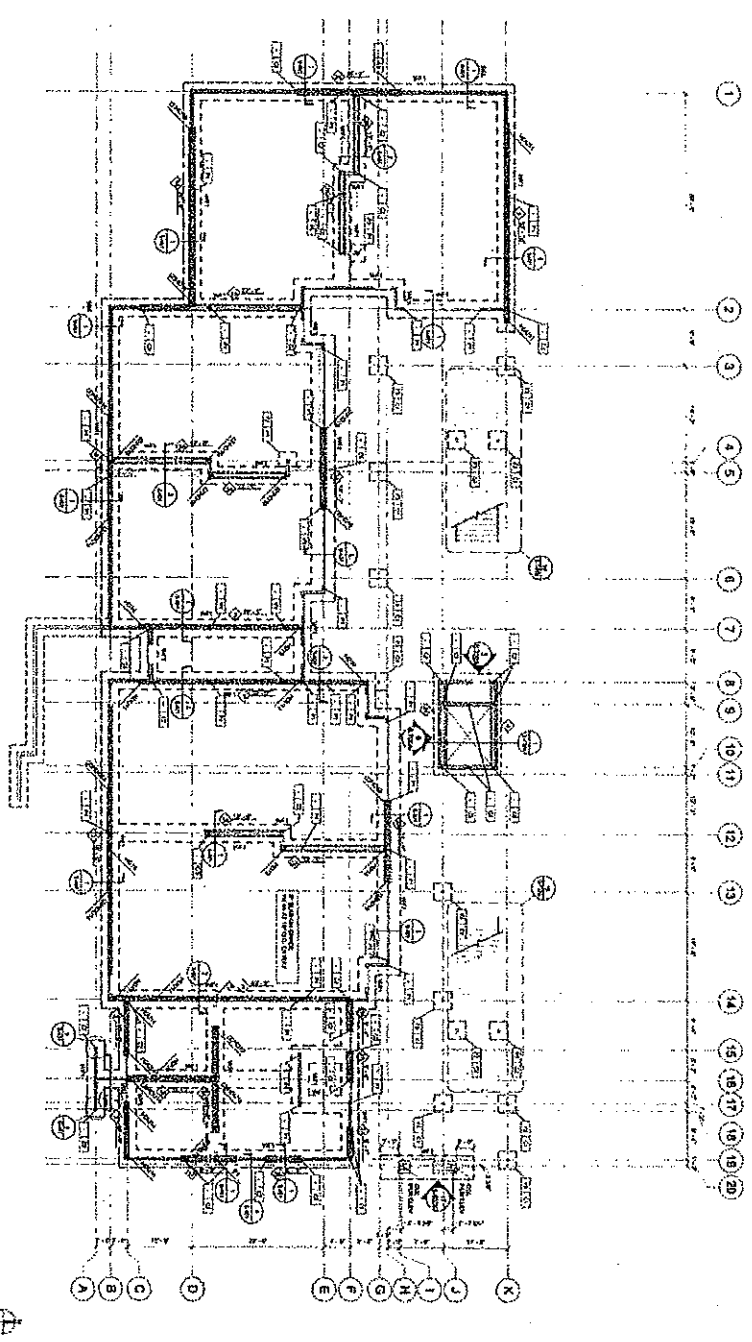

1 FOUNDATION PLAN

SHEET S-211
(FROM DSA APPROVED PLANS)
FOR REFERENCE ONLY

1. FOUNDATION PLAN
2. FOUNDATION PLAN
3. FOUNDATION PLAN
4. FOUNDATION PLAN
5. FOUNDATION PLAN
6. FOUNDATION PLAN
7. FOUNDATION PLAN
8. FOUNDATION PLAN
9. FOUNDATION PLAN
10. FOUNDATION PLAN
11. FOUNDATION PLAN
12. FOUNDATION PLAN
13. FOUNDATION PLAN
14. FOUNDATION PLAN
15. FOUNDATION PLAN
16. FOUNDATION PLAN
17. FOUNDATION PLAN
18. FOUNDATION PLAN
19. FOUNDATION PLAN
20. FOUNDATION PLAN



CSDA DESIGN GROUP

15151 Canyon Blvd., Suite 400
Denver, CO 80242
303.755.8800
www.csdaengineering.com



DENVER SCHOOL DISTRICT
MARSHALL NEW CLASSROOM BUILDING

| NO. | DATE | DESCRIPTION |
|-----|------------|-------------------|
| 1 | 01/15/2014 | ISSUED FOR PERMIT |
| 2 | 01/15/2014 | ISSUED FOR PERMIT |
| 3 | 01/15/2014 | ISSUED FOR PERMIT |
| 4 | 01/15/2014 | ISSUED FOR PERMIT |
| 5 | 01/15/2014 | ISSUED FOR PERMIT |
| 6 | 01/15/2014 | ISSUED FOR PERMIT |
| 7 | 01/15/2014 | ISSUED FOR PERMIT |
| 8 | 01/15/2014 | ISSUED FOR PERMIT |
| 9 | 01/15/2014 | ISSUED FOR PERMIT |
| 10 | 01/15/2014 | ISSUED FOR PERMIT |
| 11 | 01/15/2014 | ISSUED FOR PERMIT |
| 12 | 01/15/2014 | ISSUED FOR PERMIT |
| 13 | 01/15/2014 | ISSUED FOR PERMIT |
| 14 | 01/15/2014 | ISSUED FOR PERMIT |
| 15 | 01/15/2014 | ISSUED FOR PERMIT |
| 16 | 01/15/2014 | ISSUED FOR PERMIT |
| 17 | 01/15/2014 | ISSUED FOR PERMIT |
| 18 | 01/15/2014 | ISSUED FOR PERMIT |
| 19 | 01/15/2014 | ISSUED FOR PERMIT |
| 20 | 01/15/2014 | ISSUED FOR PERMIT |

S-211

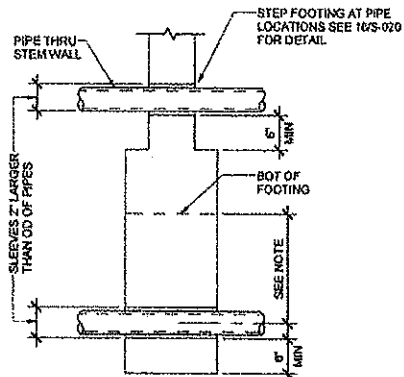

NOTE
 FOR PIPES 3'-0" OR LESS BELOW FOOTING PROVIDE SLEEVES
 AND CONCRETE AS SHOWN; MORE THAN 3'-0" COMPACT
 BACKFILL OVER PIPE TO 90% AS APPROVED BY SOILS
 ENGINEER OR USE STEPPED FOOTING BELOW PIPE.

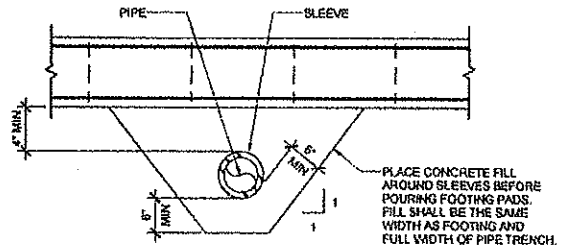

CLOSE TO BOTTOM

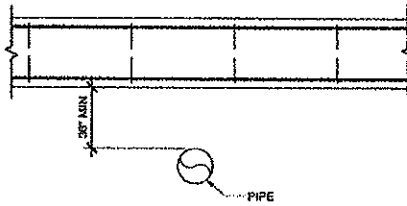

BELOW BOTTOM

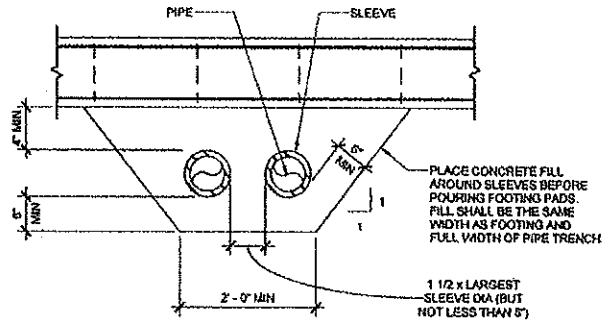

**CLOSE TO BOTTOM
 (MULTIPLE PENETRATIONS)**

1 PIPES PERPENDICULAR TO GRADE BEAM OR FOOTING
 SCALE: 3/4" = 1'-0"

DETAIL 1/S-400A
 (FROM DSA APPROVED PLANS)
 FOR REFERENCE ONLY

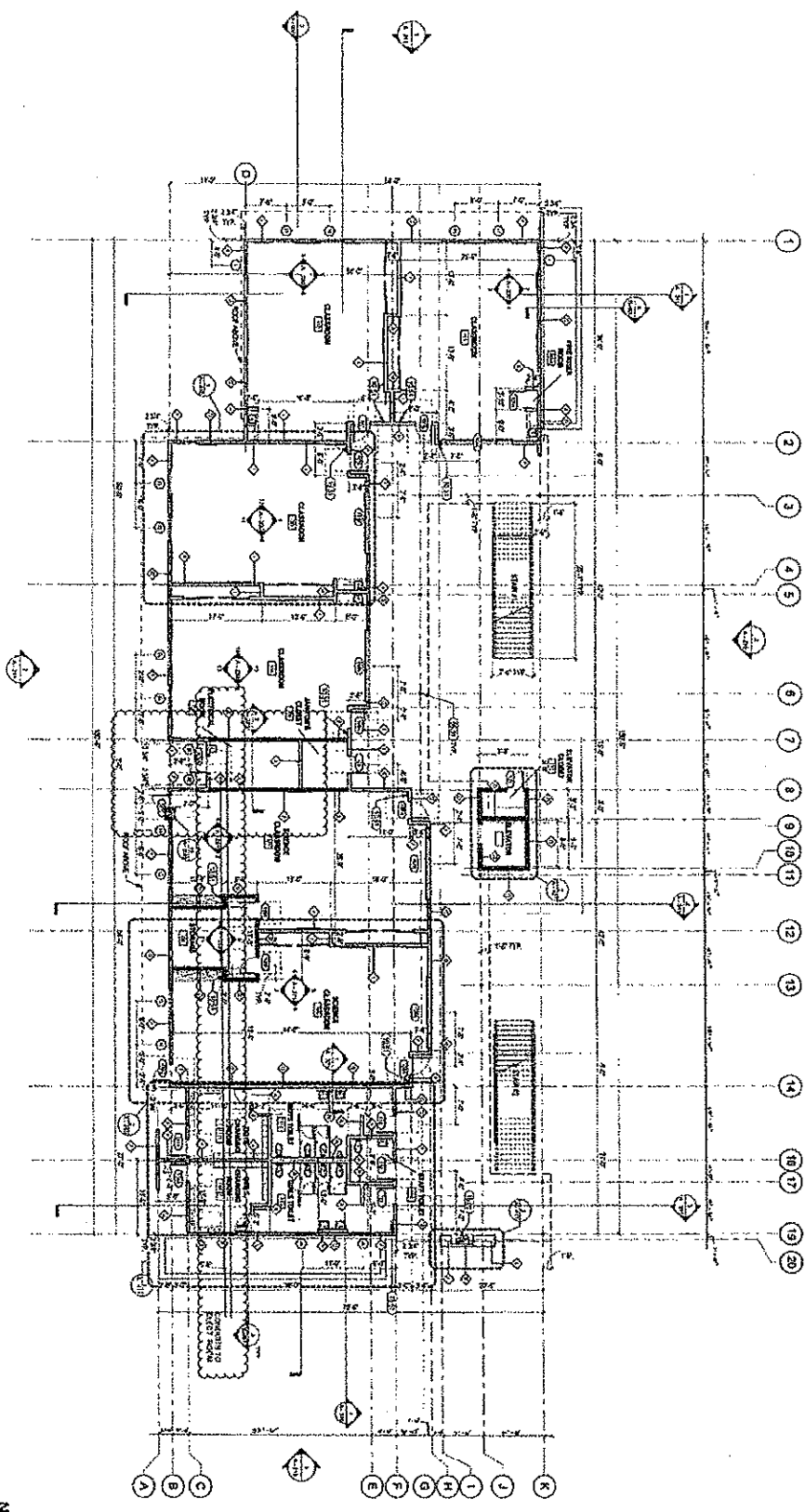

FIRST FLOOR PLAN
 1/11/11

| KEYNOTES | ACOUSTICAL NOTES | LEGEND | SHEET NOTES |
|---|---|---|--|
| <p>1. ALL ROOMS SHALL BE DESIGNED TO MEET THE REQUIREMENTS OF THE 2010 INTERNATIONAL BUILDING CODE (IBC) AND THE 2010 INTERNATIONAL MECHANICAL AND ELECTRICAL PLUMBING CODE (IMC).</p> <p>2. ALL ROOMS SHALL BE DESIGNED TO MEET THE REQUIREMENTS OF THE 2010 INTERNATIONAL BUILDING CODE (IBC) AND THE 2010 INTERNATIONAL MECHANICAL AND ELECTRICAL PLUMBING CODE (IMC).</p> | <p>1. ROOMS SHALL BE DESIGNED TO MEET THE REQUIREMENTS OF THE 2010 INTERNATIONAL BUILDING CODE (IBC) AND THE 2010 INTERNATIONAL MECHANICAL AND ELECTRICAL PLUMBING CODE (IMC).</p> <p>2. ALL ROOMS SHALL BE DESIGNED TO MEET THE REQUIREMENTS OF THE 2010 INTERNATIONAL BUILDING CODE (IBC) AND THE 2010 INTERNATIONAL MECHANICAL AND ELECTRICAL PLUMBING CODE (IMC).</p> | <p>WALL STUD WALL</p> <p>WALL STUD WALL, 1/4" x 1/4" x 1/4"</p> <p>WALL STUD WALL, 1/4" x 1/4" x 1/4"</p> <p>WALL STUD WALL, 1/4" x 1/4" x 1/4"</p> <p>WALL STUD WALL, 1/4" x 1/4" x 1/4"</p> | <p>1. FLOOR PLAN SHALL BE DESIGNED TO MEET THE REQUIREMENTS OF THE 2010 INTERNATIONAL BUILDING CODE (IBC) AND THE 2010 INTERNATIONAL MECHANICAL AND ELECTRICAL PLUMBING CODE (IMC).</p> <p>2. ALL ROOMS SHALL BE DESIGNED TO MEET THE REQUIREMENTS OF THE 2010 INTERNATIONAL BUILDING CODE (IBC) AND THE 2010 INTERNATIONAL MECHANICAL AND ELECTRICAL PLUMBING CODE (IMC).</p> <p>3. ALL ROOMS SHALL BE DESIGNED TO MEET THE REQUIREMENTS OF THE 2010 INTERNATIONAL BUILDING CODE (IBC) AND THE 2010 INTERNATIONAL MECHANICAL AND ELECTRICAL PLUMBING CODE (IMC).</p> <p>4. ALL ROOMS SHALL BE DESIGNED TO MEET THE REQUIREMENTS OF THE 2010 INTERNATIONAL BUILDING CODE (IBC) AND THE 2010 INTERNATIONAL MECHANICAL AND ELECTRICAL PLUMBING CODE (IMC).</p> |

FOR REFERENCE USE

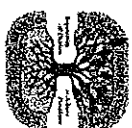

**MC CALLUM
BUILDING**

**ONWARD SCHOOL
DISTRICT**



**CSDA DESIGN
GROUP**

NO. 10/11/11

DATE 10/11/11

PROJECT ONWARD SCHOOL DISTRICT

PROJECT NO. 10/11/11

PROJECT NAME ONWARD SCHOOL DISTRICT

PROJECT LOCATION 10/11/11

PROJECT ARCHITECT CSDA DESIGN GROUP

PROJECT ENGINEER CSDA DESIGN GROUP

PROJECT CONTRACTOR 10/11/11

PROJECT OWNER ONWARD SCHOOL DISTRICT

A - 111

**FIRST FLOOR
PLAN**

FOR REFERENCE USE

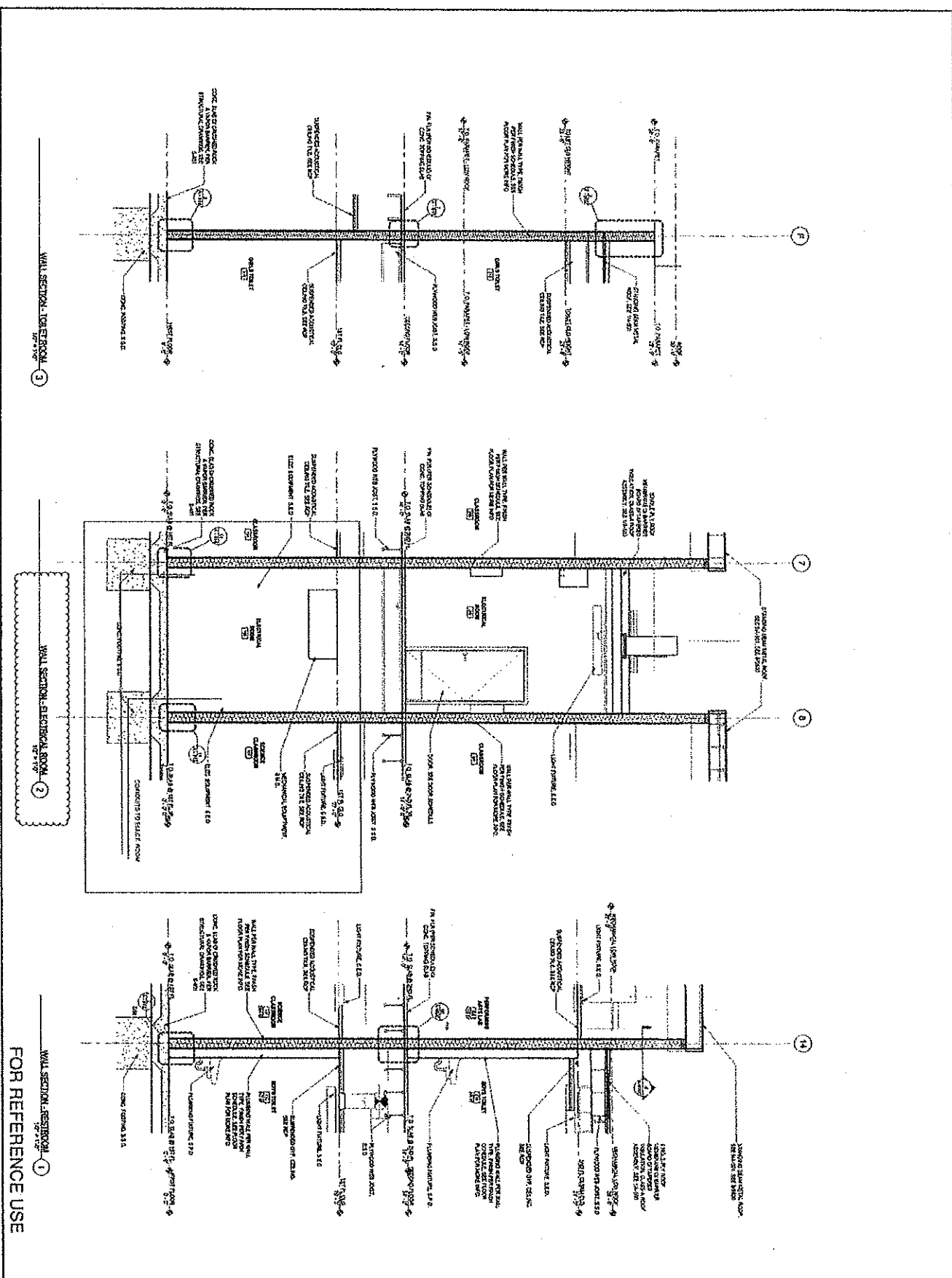

CSDA DESIGN

4415 Riverside Blvd
 Suite 100
 Irvine, CA 92614
 (949) 451-1111
 www.csdadesign.com

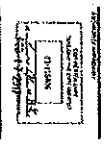

ORANGE SCHOOL DISTRICT
 ORANGE SCHOOL DISTRICT
 1000 N. TULSA AVE.
 ORANGE, CA 92668

10115 S. 10th
 Orange, CA 92668
 714-951-1111
 www.osd.net



| NO. | DESCRIPTION | DATE |
|-----|--------------------|----------|
| 1 | ISSUED FOR PERMITS | 07/20/12 |
| 2 | FOR CONSTRUCTION | 08/01/12 |
| 3 | AS NOTED | 08/01/12 |
| 4 | FOR CONSTRUCTION | 08/01/12 |
| 5 | FOR CONSTRUCTION | 08/01/12 |
| 6 | FOR CONSTRUCTION | 08/01/12 |
| 7 | FOR CONSTRUCTION | 08/01/12 |
| 8 | FOR CONSTRUCTION | 08/01/12 |
| 9 | FOR CONSTRUCTION | 08/01/12 |
| 10 | FOR CONSTRUCTION | 08/01/12 |

WALL SECTIONS
 A - 321

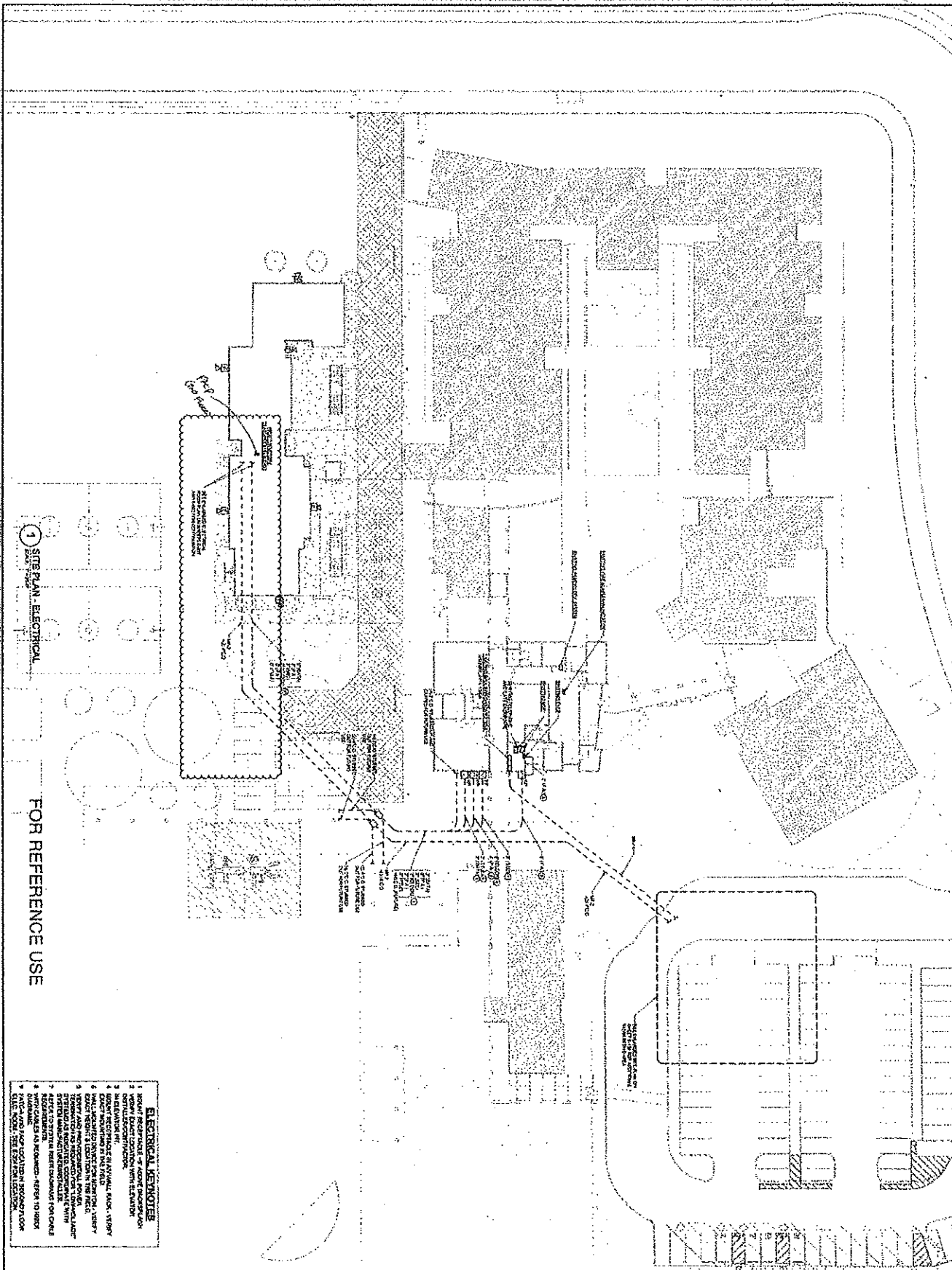

1 SITE PLAN - ELECTRICAL

FOR REFERENCE USE

- ELECTRICAL NOTES:**
1. REFER TO ARCHITECTURAL DRAWINGS FOR VERTICAL ELEVATION WITH ELEVATION.
 2. REFER TO ARCHITECTURAL DRAWINGS FOR VERTICAL ELEVATION WITH ELEVATION.
 3. REFER TO ARCHITECTURAL DRAWINGS FOR VERTICAL ELEVATION WITH ELEVATION.
 4. REFER TO ARCHITECTURAL DRAWINGS FOR VERTICAL ELEVATION WITH ELEVATION.
 5. REFER TO ARCHITECTURAL DRAWINGS FOR VERTICAL ELEVATION WITH ELEVATION.
 6. REFER TO ARCHITECTURAL DRAWINGS FOR VERTICAL ELEVATION WITH ELEVATION.
 7. REFER TO ARCHITECTURAL DRAWINGS FOR VERTICAL ELEVATION WITH ELEVATION.
 8. REFER TO ARCHITECTURAL DRAWINGS FOR VERTICAL ELEVATION WITH ELEVATION.
 9. REFER TO ARCHITECTURAL DRAWINGS FOR VERTICAL ELEVATION WITH ELEVATION.
 10. REFER TO ARCHITECTURAL DRAWINGS FOR VERTICAL ELEVATION WITH ELEVATION.

| | | | |
|---|---|--|--|
| <p>CSDA DISTRICT 1515 Orange Ave., Suite 100 Oakland, CA 94612 (415) 778-1234</p> | <p>MARSHALL SCHOOL DISTRICT 211 N. 1st St. Oakland, CA 94612 (415) 778-1234</p> | <p>Professional Engineer License No. 02-18000 J. A. & B. C.</p> | <p>Professional Engineer License No. 02-18000 J. A. & B. C.</p> |
|---|---|--|--|

PROJECT: MARSHALL NEW CLASSROOM BUILDING
DATE: 02/15/2011
SCALE: AS SHOWN
PROJECT LOCATION: 2077 Regency Blvd., Oakland, CA 94612

| NO. | DESCRIPTION | DATE |
|-----|-----------------------------------|------------|
| 1 | ISSUED FOR PERMIT | 02/15/2011 |
| 2 | REVISED PER ARCHITECTURAL CHANGES | 02/15/2011 |
| 3 | REVISED PER ELECTRICAL CHANGES | 02/15/2011 |
| 4 | REVISED PER ELECTRICAL CHANGES | 02/15/2011 |
| 5 | REVISED PER ELECTRICAL CHANGES | 02/15/2011 |
| 6 | REVISED PER ELECTRICAL CHANGES | 02/15/2011 |
| 7 | REVISED PER ELECTRICAL CHANGES | 02/15/2011 |
| 8 | REVISED PER ELECTRICAL CHANGES | 02/15/2011 |
| 9 | REVISED PER ELECTRICAL CHANGES | 02/15/2011 |
| 10 | REVISED PER ELECTRICAL CHANGES | 02/15/2011 |

DESIGNED BY: J. A. & B. C.
CHECKED BY: J. A. & B. C.
DATE: 02/15/2011

PROJECT NO.: E-101

EAST

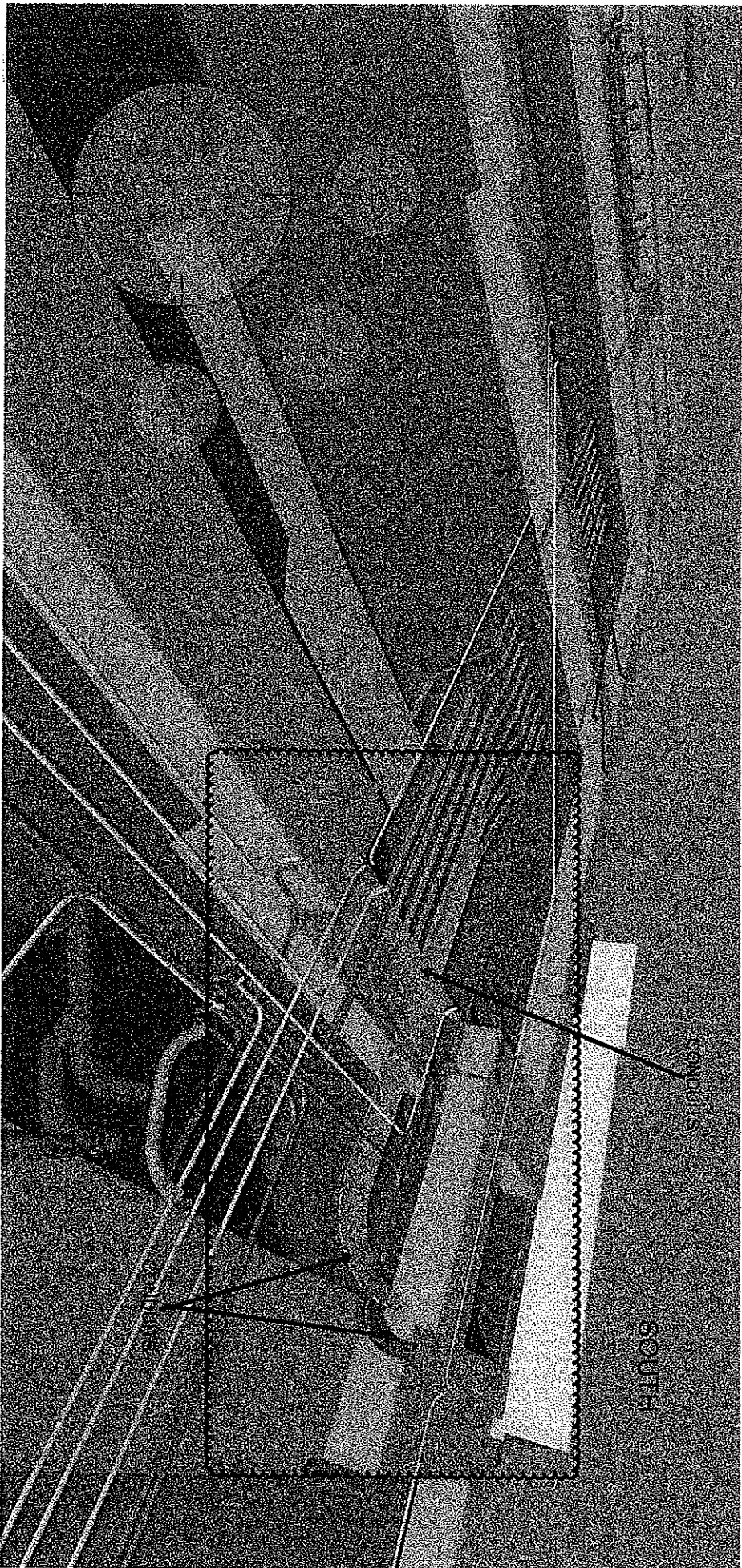

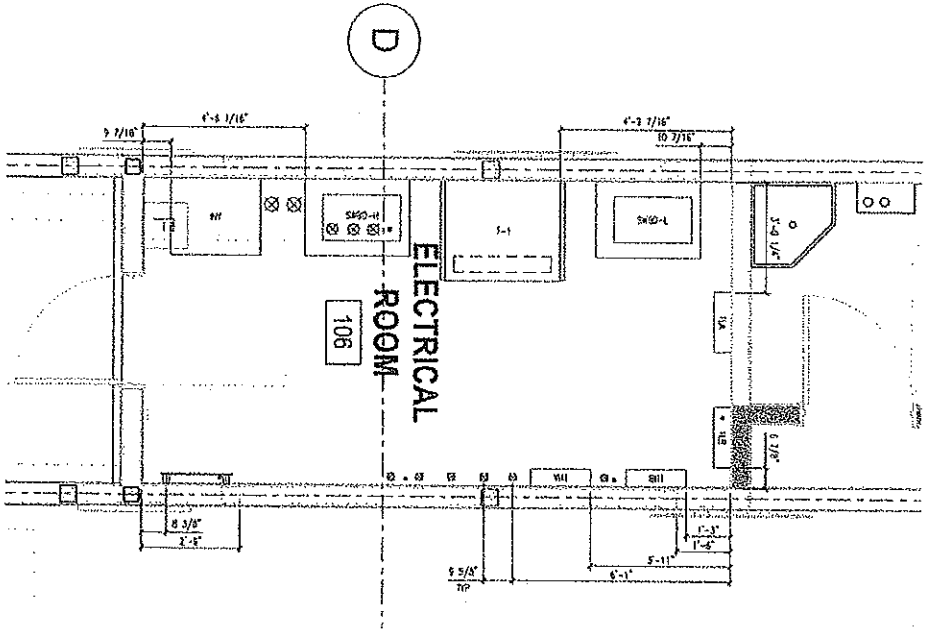

LEVEL 1 ELECTRICAL ROOM 106 LAYOUT

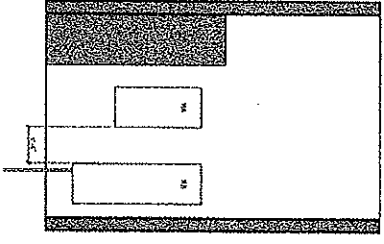
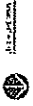

LEVEL 1 ELECTRICAL ROOM 106 NORTH ELEVATION

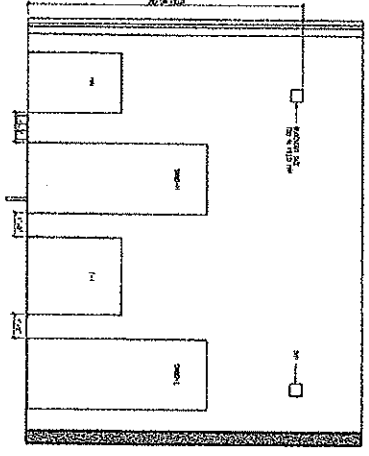

LEVEL 1 ELECTRICAL ROOM 106 WEST ELEVATION

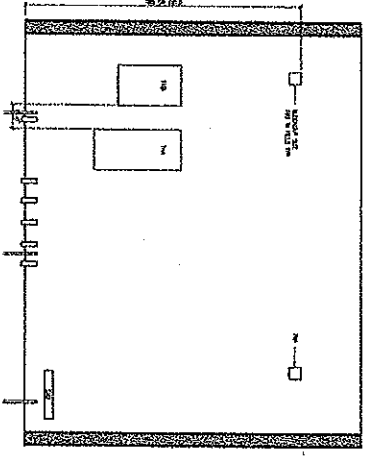

LEVEL 1 ELECTRICAL ROOM 106 EAST ELEVATION



| SYMBOL | DESCRIPTION |
|----------|---------------------|
| (Symbol) | 1. ELECTRICAL ROOM |
| (Symbol) | 2. ELECTRICAL ROOM |
| (Symbol) | 3. ELECTRICAL ROOM |
| (Symbol) | 4. ELECTRICAL ROOM |
| (Symbol) | 5. ELECTRICAL ROOM |
| (Symbol) | 6. ELECTRICAL ROOM |
| (Symbol) | 7. ELECTRICAL ROOM |
| (Symbol) | 8. ELECTRICAL ROOM |
| (Symbol) | 9. ELECTRICAL ROOM |
| (Symbol) | 10. ELECTRICAL ROOM |
| (Symbol) | 11. ELECTRICAL ROOM |
| (Symbol) | 12. ELECTRICAL ROOM |
| (Symbol) | 13. ELECTRICAL ROOM |
| (Symbol) | 14. ELECTRICAL ROOM |
| (Symbol) | 15. ELECTRICAL ROOM |
| (Symbol) | 16. ELECTRICAL ROOM |
| (Symbol) | 17. ELECTRICAL ROOM |
| (Symbol) | 18. ELECTRICAL ROOM |
| (Symbol) | 19. ELECTRICAL ROOM |
| (Symbol) | 20. ELECTRICAL ROOM |
| (Symbol) | 21. ELECTRICAL ROOM |
| (Symbol) | 22. ELECTRICAL ROOM |
| (Symbol) | 23. ELECTRICAL ROOM |
| (Symbol) | 24. ELECTRICAL ROOM |
| (Symbol) | 25. ELECTRICAL ROOM |
| (Symbol) | 26. ELECTRICAL ROOM |
| (Symbol) | 27. ELECTRICAL ROOM |
| (Symbol) | 28. ELECTRICAL ROOM |
| (Symbol) | 29. ELECTRICAL ROOM |
| (Symbol) | 30. ELECTRICAL ROOM |
| (Symbol) | 31. ELECTRICAL ROOM |
| (Symbol) | 32. ELECTRICAL ROOM |
| (Symbol) | 33. ELECTRICAL ROOM |
| (Symbol) | 34. ELECTRICAL ROOM |
| (Symbol) | 35. ELECTRICAL ROOM |
| (Symbol) | 36. ELECTRICAL ROOM |
| (Symbol) | 37. ELECTRICAL ROOM |
| (Symbol) | 38. ELECTRICAL ROOM |
| (Symbol) | 39. ELECTRICAL ROOM |
| (Symbol) | 40. ELECTRICAL ROOM |
| (Symbol) | 41. ELECTRICAL ROOM |
| (Symbol) | 42. ELECTRICAL ROOM |
| (Symbol) | 43. ELECTRICAL ROOM |
| (Symbol) | 44. ELECTRICAL ROOM |
| (Symbol) | 45. ELECTRICAL ROOM |
| (Symbol) | 46. ELECTRICAL ROOM |
| (Symbol) | 47. ELECTRICAL ROOM |
| (Symbol) | 48. ELECTRICAL ROOM |
| (Symbol) | 49. ELECTRICAL ROOM |
| (Symbol) | 50. ELECTRICAL ROOM |

| | | | | | | | |
|--|---|----------|-----------|---------|-------------|------|-------|
| TEC-1-1.8 MARSHALL ELEMENTARY SCHOOL ARCHITECT E. J. SMITH 12-1-47 12-1-47 | DAY ELECTRIC COMPANY 1746 Exchange Street, Columbus, OH 31906 TEL: 678-2211 FAX: 678-2211 | REV. NO. | REVISIONS | REV. BY | EXPLANATION | DATE | SCALE |
| | | | | | | | |

© 1987 DAY ELECTRIC COMPANY, COLUMBUS, OHIO

APPLICATION FOR APPROVAL OF CONSTRUCTION CHANGE DOCUMENT - CCD CATEGORY A/B

This application is for construction changes, as defined in IR A-6, to approved contract documents. This form shall be completed by the Design Professional in General Responsible Charge of the project, in accordance with California Code of Regulations, Title 24, Part 1, Section 4-338 (c) and in compliance with DSA IR A-6.

| | |
|--|-------------------------|
| School District/Owner: Oxnard School District | DSA File #: 56 - 22 |
| Project Name/School: Marshall Elementary School New Classroom Building | DSA App. #: 03 - 116806 |

| APPLICANT | | |
|---|------------------------------|--|
| CCD Cat. <input checked="" type="checkbox"/> A / <input type="checkbox"/> B, #012 | Date Submitted: 12/18/17 | Attached Pages?: <input type="checkbox"/> No <input checked="" type="checkbox"/> Yes (4 ___ pages) |
| For CCD Cat. B, this is a <input type="checkbox"/> voluntary submittal, <input type="checkbox"/> DSA required submittal (attach DSA notification requiring submission). | | |
| Firm Name: CSDA Design Group | Contact Name: Michael Schoen | |
| Email: mschoen@csdadesigngroup.com | Phone Number: (310) 301-4772 | |
| Address: 889 N Douglas St, Suite 100 | | |
| City: El Segundo | State: CA | Zip: 90245 |
| <input type="checkbox"/> A DSA 301-N, DSA 301-P, or 90-Day Letter has been issued for this project. | | |
| <input checked="" type="checkbox"/> For project currently under construction. | | |
| <input type="checkbox"/> To obtain DSA approval of existing uncertified building(s). | | |

| DESIGN PROFESSIONAL IN GENERAL RESPONSIBLE CHARGE | |
|---|-----------------------|
| Name of Design Professional in General Responsible Charge: Michael Schoen | |
| Professional License #: C-35165 | Discipline: Architect |

Design Professional in General Responsible Charge Statement: The attached Construction Change Documents have been examined by me for design intent and appear to meet the appropriate requirements of Title 24, California Code of Regulations and the project specifications. They are acceptable for incorporation into the construction of the project.

Signature: *[Signature]*
 DESIGN PROFESSIONAL IN GENERAL RESPONSIBLE CHARGE

CHECK THIS BOX: To confirm that all CCD drawings and, when applicable, first sheet or index of calculations and specifications have been stamped and signed by the Responsible Design Professional listed on DSA 1 for this project.

Brief description of construction change (attach additional sheets if needed):
 Due to excess reinforcement at the footing denoted in SSK-01, Stepped Footing detail, 16/S-400, is to be modified such that the lap splice length is reduced per attached SSK-02.

List of DSA approved drawings affected by this CCD: S-211, S-400

| DSA USE ONLY | | DSA Stamp | |
|---|---|--|--------|
| SSS_ST Date 1/02/18 <input checked="" type="radio"/> Approved <input type="radio"/> Disapproved / <input type="radio"/> Not Req'd | For business office use only Date Sent _____ Return By _____ Delivery Method _____ |  APPROVED DIV. OF THE STATE ARCHITECT LOS ANGELES REGIONAL OFFICE DATE 01/02/2018 Appl. No: 03-116806 140 012.pdf | stuong |
| FLS Date _____ <input type="radio"/> Approved / <input type="radio"/> Disapproved / <input type="radio"/> Not Req'd | | | |
| ACS Date _____ <input type="radio"/> Approved / <input type="radio"/> Disapproved / <input type="radio"/> Not Req'd | | | |
| Remarks _____ | | | |

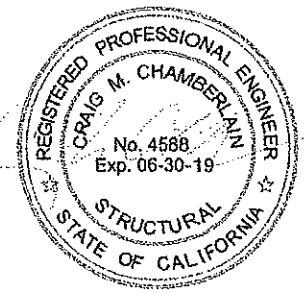

FOOTING REPAIR TO
REMAIN CONTINUOUS

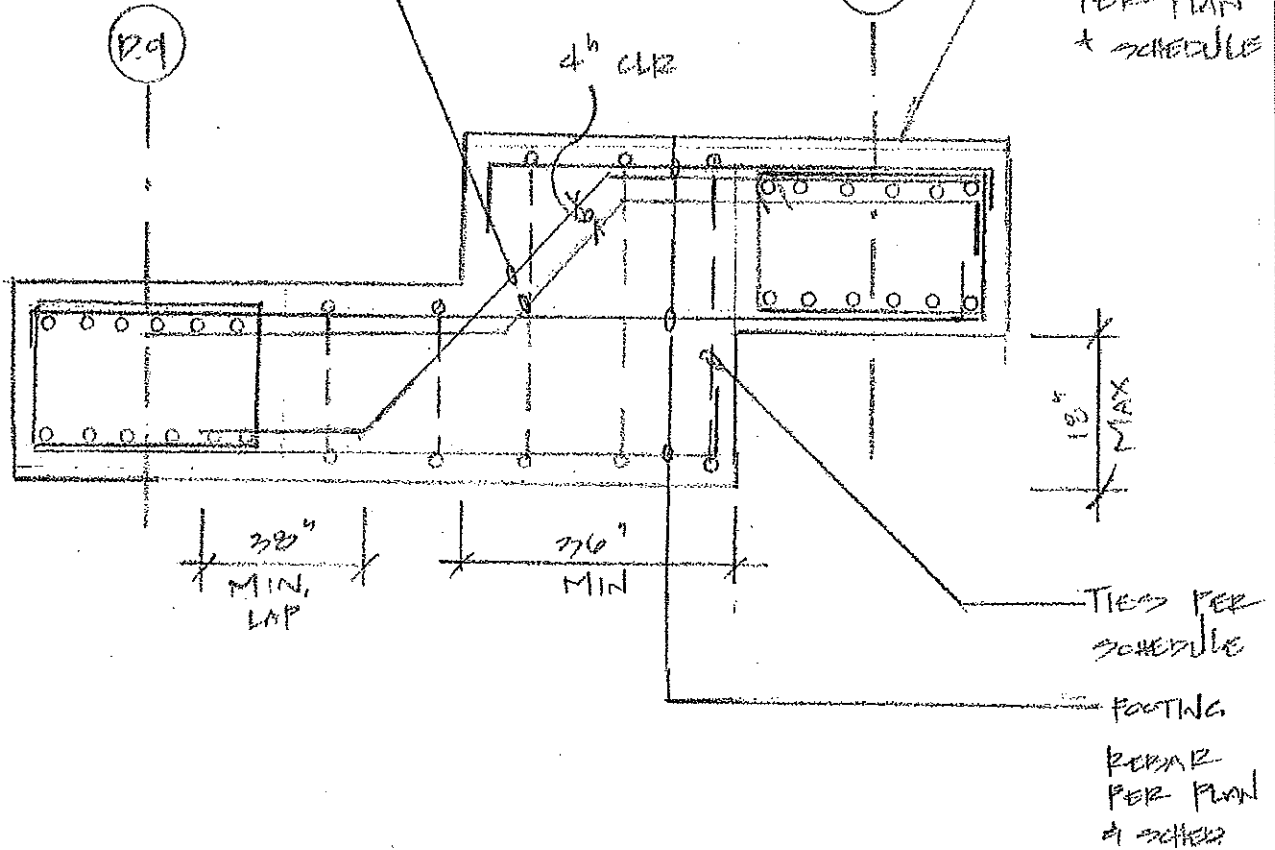

DSA APPROVED sluong
 DIV. OF THE STATE ARCHITECT
 LOS ANGELES REGIONAL OFFICE
 DATE 01/02/2018
 Appl. No: 03-116806_140_012.pdf

REVISED DETAIL

Description of change:

Existing detail is modified to reduce required lap splice length at locations specified in SSK-CCD012-01.

referenced drawings/details: 16/S-400, S-211, SSK-CCD012-01

**NISHKIAN
CHAMBERLAIN**
 CONSULTING AND STRUCTURAL
 ENGINEERS SINCE 1919
 NC PROJECT # 40340

| | | |
|---|---|--------------------------|
| CSDA PROJECT #: 1534.01 | SHEET: 02 OF 02 | CSDA DESIGN GROUP |
| MARSHALL ES - NEW CLASSROOM BUILDING 2900 Thurgood Marshall Dr, Oxnard, CA 93036 | DRAWING REFERENCE: 16/S-400 | |
| | SCALE: NTS | |
| | DATE: 12/14/2017 | |
| DSA A# 03-116806 | Title of sheet Revised Stepped Footing Detail 16/S-400 | CCD #012 |
| | | SSK-CCD012-02 |



CHANGE ORDER REQUEST

Project: Marshall Elementary - New 6-8 Classroom Bldg.

COR No. 17 R0
Date: 3/22/2018

DESCRIPTION OF WORK

Per RFI 85 Redesign Science classroom 107,109,208

SUMMARY OF COSTS

| Item Description | Company | Amount Requested |
|---|-------------------------|------------------|
| Subcontract Costs | | |
| Per RFI 85 Redesign Science classroom 107,109,208 | Sheldon Mechanical Corp | 2,440 |
| | Subtotal: | 2,440 |
| Total Change Order Request Amount | | 2,440 |

APPROVAL

(Please note that if this Change Order Request is not approved by , additional costs and schedule impacts may result)

Oxnard School District

Bernards Bros. Inc.

Signature

Printed Name & Title

Date

Signature

Printed Name & Title

Date

Shanika McJannet
CFW Program Mgr.



CHANGE ORDER REQUEST

Project: Marshall Elementary - New 6-8 Classroom Bldg.

COR No. 17 R0

Date: 3/22/2018

DESCRIPTION OF WORK

Per RFI 85 Redesign Science classroom 107,109,208

SUMMARY OF COSTS

| Item Description | Company | Amount Requested |
|---|-------------------------|------------------|
| Subcontract Costs | | |
| Per RFI 85 Redesign Science classroom 107,109,208 | Sheldon Mechanical Corp | 2,440 |
| | Subtotal: | 2,440 |
| Total Change Order Request Amount | | 2,440 |

APPROVAL

(Please note that if this Change Order Request is not approved by , additional costs and schedule impacts may result.)

Oxnard School District

Bernards Bros. Inc.

Signature

Signature

Printed Name & Title

Printed Name & Title

Date

Date



SHELDON MECHANICAL CORPORATION

February 12, 2017

Bernards
555 1st Street
San Fernando, Ca. 91340

Attn: Ms. Rebecca Miller

Subject: Marshall Elementary Classroom Building
SMC COR #3 RFI #85 Science Classroom 107, 109 and 208 Redesign

Dear Rebecca,

Below is our cost associated with RFI #85 for the additional shop drawing time to relocate our ductwork due to conflicts with structural beams.

| | |
|-------------------------------------|-------------------|
| Detailer (20 Hours @ \$106.10)..... | \$2,122.00 |
| Sub Total..... | <u>\$2,122.00</u> |
| Overhead and Profit – 15%..... | \$318.00 |
| Cost for SMC COR #3..... | \$2,440.00 |

If you have any questions please call me.

Sincerely,

Dillon J. Boute'

Dillon J. Boute'

SHELDON MECHANICAL CORPORATION

26015 Avenue Hall, Santa Clarita, CA 91355 Office: (661) 286-1361 Fax: (661) 287-9083
California State Contractors License Number 463722 – C20, C38



**REQUEST FOR INFORMATION
FOR SUBCONTRACTOR ACTION**

RFI No. : 85

Project: Marshall Elementary - New 6-8 Classroom Bldg.

Date: 12-12-17

Discipline: Mechanical

Subject: Science classroom 107,109 and 208 Redesign

DRAWING & SPECIFICATION REFERENCES

| Drawing Sheet / Specification | Detail / Sub Section | Comments |
|-------------------------------|----------------------|----------|
|-------------------------------|----------------------|----------|

QUESTION

Structural Beams are in conflict with the ductwork as designed for Science classrooms 107,109 and 208. This has caused Sheldon Mechanical to redesign the ductwork as part of the BIM Coordination process

SUGGESTION

Please review Sheldon Mechanical Changes and redesign, and verify if the changes are acceptable

ANSWER

Response:

Suggested revision is acceptable

Responded by:
Vazgen ohanian

RESPONSE DISTRIBUTION

| Company | Contact | Date Sent |
|--------------------------------|---------------|------------|
| City Commercial Plumbing Inc | Bob Zio | 12/12/2017 |
| Sheldon Mechanical Corp | Dillion Boute | 12/12/2017 |
| JG Tate Fire Protection System | Jim Tate | 12/12/2017 |
| Taft Electric Co | Matt Gobuty | 12/12/2017 |

Please review and advise Bernards, **WITHIN 7 days**, if there are any additional costs or schedule impacts associated with incorporating the RFI response with the Contract Work. (Include a brief description and rough order estimate of the change with this notification. If no response is received within 7 days, Bernards shall trust that there is no impact to your Contract Price or Schedule.

Question Initiated By: Dillion Boute - Sheldon Mechanical Corp - Author Number: 3
Submitted By: Dillion Boute - Sheldon Mechanical Corp



REQUEST FOR INFORMATION

RFI No.: 85

To: Jose Arche
Company: CSDA Design Group
Project: Marshall Elementary - New 6-8 Classroom Bldg.

Date: 12-11-17
Discipline: Mechanical

Subject: Science classroom 107,109 and 208 Redesign

Response Requested By: 12-18-2017

DRAWINGS & SPECIFICATION REFERENCES

| Drawing Sheet / Specification | Detail / Sub Section | Comments |
|-------------------------------|----------------------|----------|
|-------------------------------|----------------------|----------|

QUESTION

Structural Beams are in conflict with the ductwork as designed for Science classrooms 107,109 and 208. This has caused sheldon Mechanical to redesign the ductwork as part of the BIM Coordination process

SUGGESTION

Please review Sheldon Mechanical Changes and redesign, and verify if the changes are acceptable

ANSWER

Suggested revision is acceptable.

| | | | |
|-----------------------|----------------|------------------|---------------|
| Response Provided By: | Vazgen ohanian | CDME, Inc. | 12/11/17 |
| | _____ Name | _____ Company | _____ Date |

Question Initiated By: Dillion Boute - Sheldon Mechanical Corp - Author Number: 3
Submitted By: Dillion Boute - Sheldon Mechanical Corp



26015 Avenue Hall
Santa Clarita, CA 91355
Phone: 661.286.1361
Fax: 661.287.9086

Request For Information

RFI NO: 4

DATE: 12/11/2017

TO: Bernards

ATTN: Rebecca Miller

JOB: Marshall Elementary [4358]

A/E:

SUBJECT: Classrooms 107, 109 and 208 Duct Redesign

REF:

INFORMATION REQUESTED:

Structural Beams are in conflict with the ductwork as designed for Science Classrooms 107, 109 and 208. This has caused Sheldon Mechanical to redesign the ductwork as part of the BIM Coordination process.

Suggestion

Review Sheldon Mechanical changes and redesign. Please verify changes are acceptable and meeting project requirements.

REPLY REQUIRED: Yes

COST IMPACT: POSSIBLE

SCHEDULE IMPACT: POSSIBLE

FURTHER ACTION:

STATUS:

12

13

14

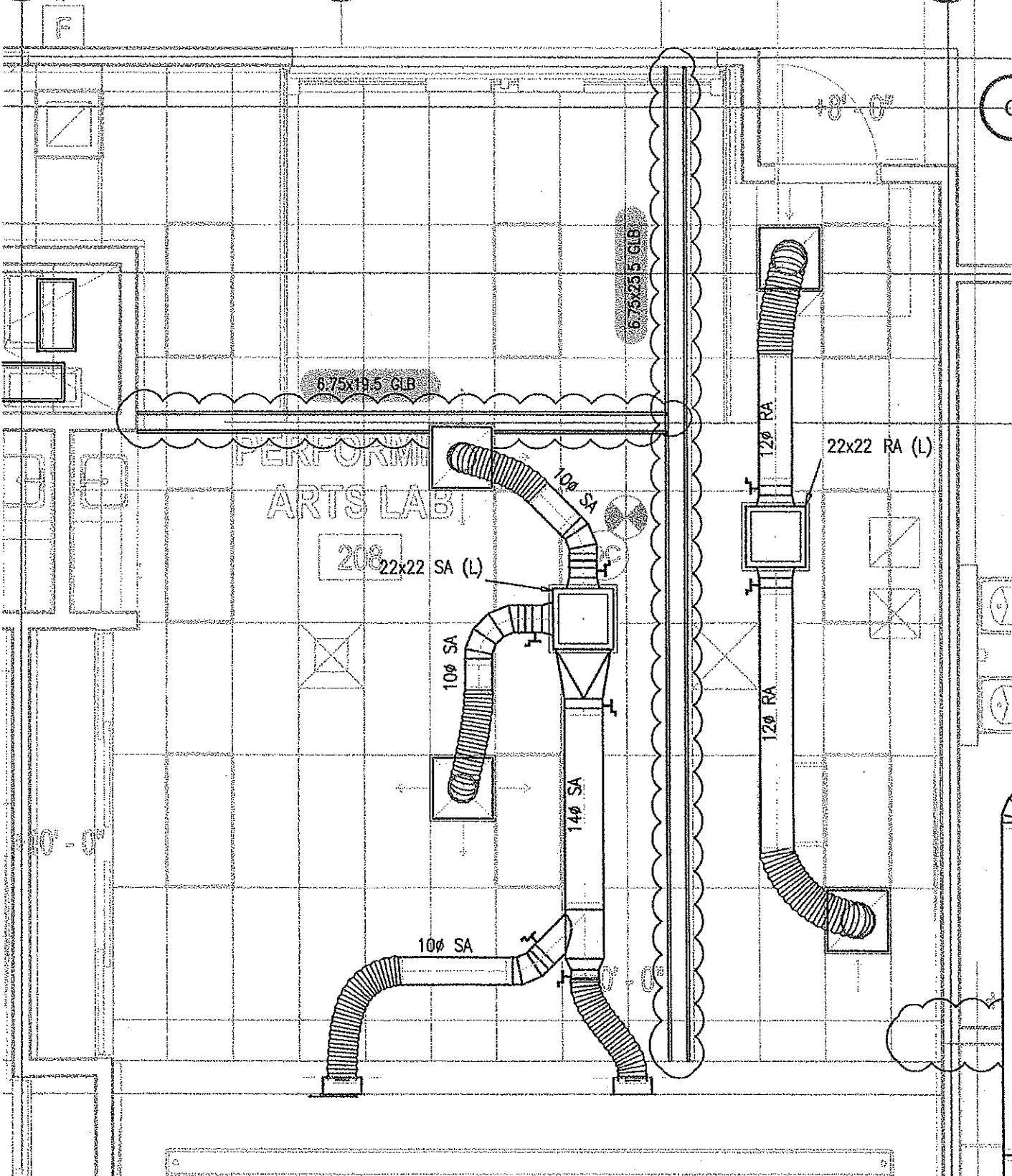

PERFORMING ARTS LAB 208
 DUCT REDESIGN FOR LOW BEAMS

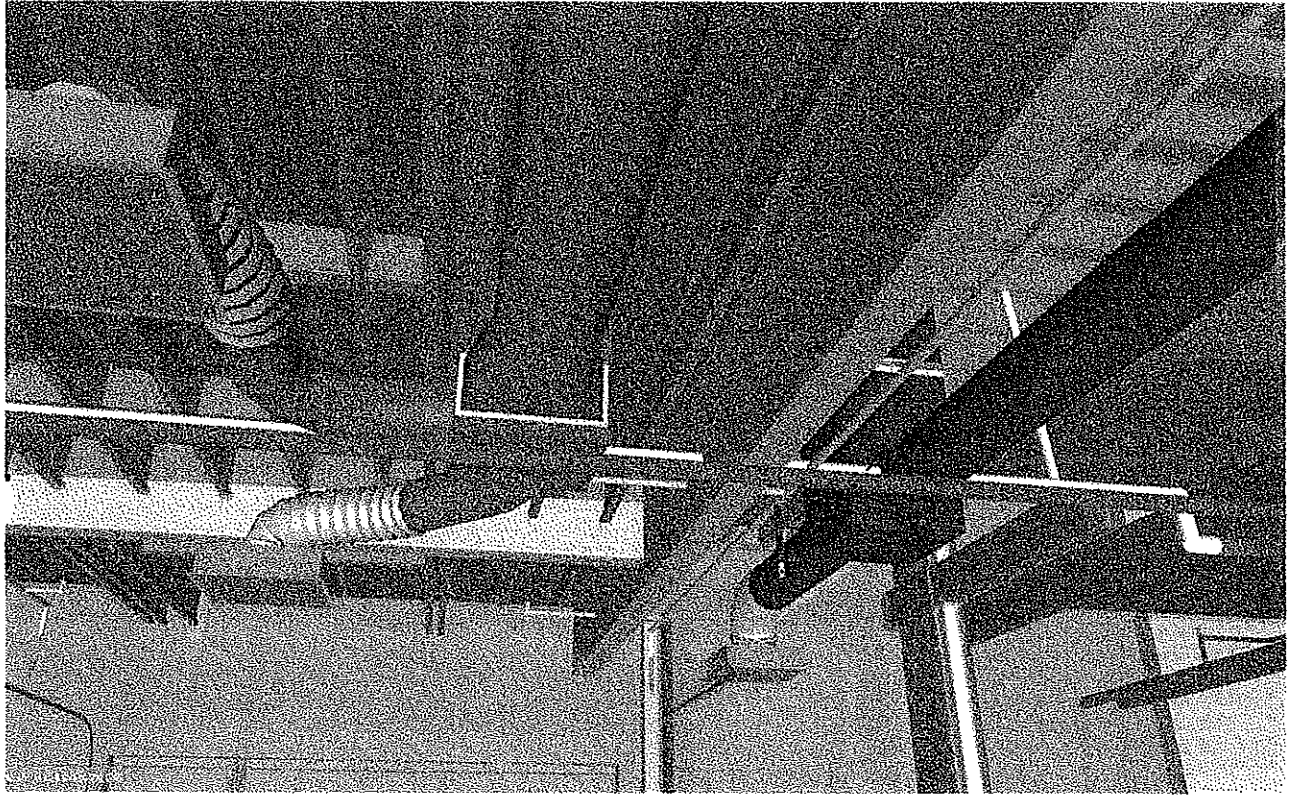

CHANGE ORDER LOG

JOB #: 4358

| SMC C/O #: | DESCRIPTION | AMOUNT SUBMITTED | DATE SUBMITTED | AMOUNT APPROVED | DATE APPROVED | AMT NOI APPROVED | Notes | GC CO | % COMPLETE | COST INCURRED |
|---------------|---|------------------|----------------|-----------------|---------------|------------------|------------|-------|------------|---------------|
| 1 | RFI #65 RI Water Heater Make-Up Air Ductwork and Flue | \$12,036.00 | 12/4/2017 | Void | | | By Plumber | | | |
| 2 | RFI #110 Air Distribution Ceiling Cans | \$ 8,725.00 | 1/17/2018 | | | | | | | |
| 3 | RFI #85 Science Classroom 107, 109 and 208 Redesign | \$2,440.00 | 2/12/2018 | | | | | | | |
| 4 | RFI #99 RTU Power Exhausts | | | | | | To Follow | | | |
| 5 | | | | | | | | | | |
| 6 | | | | | | | | | | |
| 7 | | | | | | | | | | |
| 8 | | | | | | | | | | |
| 9 | | | | | | | | | | |
| 10 | | | | | | | | | | |
| 11 | | | | | | | | | | |
| TOTAL TO DATE | | \$ 23,201.00 | | | | \$ | | | | |

#17-117

CONSTRUCTION SERVICES AGREEMENT

This Construction Services Agreement (hereinafter referred to as the "Agreement") is entered into this 24th day of August 2017, by and between the Oxnard School District, a California school district organized and existing under the laws of the State of California (hereinafter referred to as the "District") and Bernards which is a contractor licensed by the State of California, with its principal place of business at 555 First Street, San Fernando, CA 91340 (hereinafter referred to as "Contractor").

WHEREAS, the District operates Marshall Elementary School, located at 2900 Thurgood Marshall Drive, Oxnard, California 93036 (hereinafter referred to as the "School Facility"); and

WHEREAS, the District desires to construct and modernize facilities and improvements (as more fully described below) at those portions of the School Facility identified in the Site Lease, as defined in Section 1G below (the "Site"); and

WHEREAS, the District has determined that it is in its best interests to pursue the improvements to the School Facility through the lease-leaseback method of project delivery pursuant to California Education Code §17406 which permits the governing board of the District, without advertising for bids, to lease to Contractor property owned by the District if the instrument by which property is leased requires the lessee to construct, or provide for the construction, on the leased property, of a facility for the use of the District during the term of the lease, and provides that title to that facility shall vest in the District at the expiration of the lease; and

WHEREAS, the District desires to finance a portion of the improvements utilizing the lease/leaseback methodology; and

WHEREAS, the District has conducted an RFQ process by which it selected Contractor; and

WHEREAS, the District intends to undertake work to improve the School Facility, the scope of which is generally described in **Exhibit A** attached hereto and incorporated by reference herein; and

WHEREAS, in connection with the approval of this Agreement, the District will enter into a site lease with Contractor, under which it will lease to Contractor the Site in order for Contractor to construct the Project as described in the Scope of Work set forth generally in **Exhibit A** (hereinafter referred to as the "Scope of Work"); and

WHEREAS, assuming that the District and Contractor can agree on the terms, including the price, for the additional scope of work, the District and Contractor anticipate that the scope of the Project may be amended to include additional work; and

- 1 -

OXNARD SCHOOL DISTRICT

CONSTRUCTION SERVICES AGREEMENT

Marshall New Classroom Building Project

August 24th, 2017

#17-117

WHEREAS, Contractor will lease the Site back to the District pursuant to a sublease agreement, under which the District will be required to make payments to Contractor for the use and occupancy of the Site, including the Project (hereinafter the "Financing"); and

WHEREAS, Contractor represents that it is sufficiently experienced in the construction of the type of facility and type of work sought by the District and is willing to perform said work for lease and the Financing to the District, all as more fully set forth herein; and

WHEREAS, at the expiration of the Site Lease, title to the Site and the improvements thereon will vest with the District;

NOW, THEREFORE, in consideration of the covenants hereinafter contained, the District and Contractor agree as follows:

SECTION 1. DEFINITIONS

- A. **Construction.** The term "Construction" as used in this Agreement includes all labor and services necessary for the construction of the Project, and all materials, equipment, tools, supplies and incidentals incorporated or to be incorporated in such construction as fully described in the Scope of Work set forth in **Exhibit A** attached hereto. Unless otherwise expressly stipulated, Contractor shall perform all work and provide and pay for all materials, labor tools and equipment, including, but not limited to, light, water, and power, necessary for the proper execution and completion of the Project shown on the drawings and described in the specifications developed pursuant to this Agreement.
- B. **Construction Documents.** The term "Construction Documents" means the final drawings, profiles, cross sections, design development drawings, construction drawings, and supplemental drawings based on the plans and specifications developed for the Project pursuant to the Scope of Work set forth in **Exhibit A** attached hereto, including any reference specifications or reproductions prepared by the architect hired by the District (the "Architect") and specifications approved by the District, the Division of the State Architect ("DSA"), and the local agencies having jurisdiction or other regulatory agencies whose approval may be required, which show or describe the location, character, dimensions or details for the Project and specifications for construction thereof.
- C. **Contract Documents.** The term "Contract Documents" as used in this Agreement refers to those documents which form the entire agreement by and between the District and Contractor. The Contract Documents consist of this Agreement, including the exhibits and attachments hereto, the Site Lease, including the exhibits and

#17-117

attachments thereto, the Sublease, including the exhibits and attachments thereto, the Project Manual including the General Conditions thereto, as amended, which is incorporated herein (the "General Conditions"), and the Construction Documents. The term "Contract Documents" shall include all modifications and addenda thereto.

- D. **Guaranteed Maximum Price.** The term "Guaranteed Maximum Price" or "GMP" as used in this Agreement means the Guaranteed Maximum Price established pursuant to Section 5 of this Agreement to be used to calculate the Tenant Improvement Payments and the Sublease Payments to be paid by the District to Contractor pursuant to the Sublease, subject only to any adjustments for Extra Work/Modifications as provided in Section 10 of this Agreement.
- E. **Not Used for this Agreement**
- F. **Project.** The term "Project" shall mean the improvements and facilities to be constructed and installed by Contractor at the School Facility which will result in complete and fully operational facilities as more fully set forth on **Exhibit A** attached hereto.
- G. **Project Manual.** The term "Project Manual" shall mean the compilation of the Specification sections including Division 0, Procurement and Contracting Requirements, Division 1 General Requirements, and technical specifications Division 2 through 33 prepared by the Architect and approved by the District, the DSA, or other regulatory agencies which show or describe the location, character, dimensions or details for the Project, which shall be delivered to Contractor upon execution of this Agreement.
- H. **Site.** The term "Site" as used in this Agreement shall mean those certain parcels of real property and improvements thereon (if any) more particularly described in **Exhibit A** to the Site Lease.
- I. **Site Lease.** The term "Site Lease" as used in this Agreement shall mean the certain Site Lease dated of even date herein between the District and Contractor, together with any duly authorized and executed amendment(s) thereto, pursuant to which the District leases the Site to Contractor.
- J. **Specifications.** The term "Specifications" shall mean those numbered specifications set forth in the Project Manual which shall accompany this Agreement and which are incorporated by reference herein. Individual Specifications may be referred to by their specification number as set forth in the Project Manual.

#17-117

- K. **Subcontractor.** As used in this Agreement, the term "Subcontractor" means any person or entity, including trade contractors, who have a contract with Contractor to perform any of the Construction.
- L. **Sublease.** The term "Sublease" as used in this Agreement shall mean the certain Sublease dated of even date herein between the District and Contractor, together with any duly authorized and executed amendment(s) thereto, pursuant to which the District subleases the Site from Contractor.
- M. **Sublease Payments.** The term "Sublease Payments" as used in this Agreement shall mean the payments made by the District to Contractor pursuant to Section 6 of the Sublease.
- N. **Tenant Improvement Payments.** The term "Tenant Improvement Payments" as used in this Agreement shall mean the payments made by the District to Contractor pursuant to Section 6 of the Sublease.

SECTION 2. CONTRACTOR'S DUTIES AND STATUS

Contractor covenants with the District to furnish reasonable skill and judgment in constructing the Project. Contractor agrees to furnish efficient business administration and superintendence and to furnish at all times an adequate supply of professionals, workers, and materials and to perform the work appropriately, expeditiously, economically, and consistent with the Contract Documents.

SECTION 3. ADDITIONAL SERVICES

If the District requests Contractor to perform additional services not described in this Agreement, Contractor shall provide a cost estimate and a written description of the additional work necessary to complete such additional services. The cost for such additional services shall be negotiated and agreed upon in writing in advance of Contractor performing or contracting for such additional services, and such cost shall be used to adjust the GMP established pursuant to Section 5 hereof. In the absence of a written agreement, the District will not compensate Contractor for additional services, will not adjust the GMP for such additional services, and Contractor will not be required to perform them. It is understood and agreed that if Contractor performs any services that it claims are additional services without receiving prior written approval from the District Board of Education, Contractor shall not be paid for such claimed additional services and the GMP will not be adjusted. Nothing in this Agreement shall be construed as limiting the valuation of such additional services and amount that the GMP will be adjusted for such additional services, should a written agreement for such services be executed by the parties. Notwithstanding the foregoing, Contractor shall not be entitled to compensation, nor will the GMP be adjusted, for additional services required as a result of Contractor's acts, errors or omissions.

SECTION 4. OWNERSHIP OF PLANS AND DOCUMENTS

All original field notes, written reports, drawings, specifications, Construction Documents, and other documents, produced or developed for the Project are the property of the District, regardless of whether the Project is constructed, and shall be furnished to the District. Such documents are not to be used by Contractor or by the Subcontractors on other work nor shall Contractor nor the Subcontractors claim any right to such documents. This shall not deprive Contractor from retaining electronic data or other reproducible copies of the Construction Documents or the right to reuse information contained in them in the normal course of Contractor's professional activities.

SECTION 5. ESTABLISHMENT OF GUARANTEED MAXIMUM PRICE

The "GMP" for the Project shall be **Eight Million Nine Hundred Ninety-Four Thousand Two Hundred Thirty-Six and No/Hundredths Dollars (\$8,994,236.00)**. The GMP consists of (1) no Preconstruction Fee, a Sublease Tenant Improvement Payment in the amount of **Eight Million One Hundred Ninety-Eight Thousand Five Hundred Ninety-Two Dollars and No Cents (\$8,198,592.00)** and, (2) a Contractor Contingency in the amount of **Three Hundred Forty-Five Thousand Nine Hundred Thirty-Two Dollars and No Cents (\$345,932.00)**, and, (3) Sublease Payments in the amount of **\$74,952.00** per month for **6** months, for a total lease value of **Four Hundred Forty-Nine Thousand Seven Hundred Twelve Dollars and No Cents (\$449,712.00)** pursuant to terms and payment schedule as set forth in the Sublease. THE "GMP" WILL NOT BE ESTABLISHED UNTIL DSA HAS APPROVED THE FINAL PLANS AND SPECIFICATIONS AND THE BOARD APPROVES IT PRIOR TO NTP FOR CONSTRUCTION. The GMP will then be brought to the Board of Trustees as a revision to this section of this agreement. Until such time this section will remain incomplete, the Site Lease and Sublease will not begin and the Contractor will proceed with subcontractor bidding to establish the final GMP for Board acceptance.

The GMP is based upon the DSA approved plans and specifications to exist after this Agreement is entered into between Contractor and the District, and more fully described and referenced in the Scope of Work to be set forth in **Exhibits A and B** attached hereto. Prior to DSA approval Contractor did not perform Preconstruction Services to assist in designing the project. Upon DSA approval of plans and specifications, and the establishment of the GMP the Contractor shall assume the risk of cost overruns which were foreseeable at the time this Agreement is entered into and the GMP determined, except for undocumented events of the type set forth in Section 19 hereof, work mandated by an outside agency after issuance of Construction Documents that could not have been reasonably foreseen from review of the Contract Documents, or costs arising from undocumented geotechnical issues. Contractor acknowledges that (i) Contractor has conducted a site inspection and is familiar with the site conditions based on records, studies and visible conditions relating to construction and labor and (ii) Contractor has reviewed the Contract Documents and is familiar with the contents thereof. District directed changes to the scope of the Project not contemplated in the Scope of Work shall

#17-117

be deemed Extra Work/Modifications pursuant to the procedures set forth in Section 10 of this Agreement. The GMP shall include, but not be limited to, increases in labor and materials. The GMP has been used to calculate the Tenant Improvement Payments and the Sublease Payments to be paid by the District to Contractor pursuant to the Sublease. The GMP includes the cost of all labor, materials, equipment, general conditions, overhead, profit and a Contractor Contingency as indicated above.

The Contractor Contingency is for the purpose of covering the cost of very specific issues that may arise during construction and it may be used only upon the written agreement of the Contractor, the architect of record, and the District. The Contractor Contingency is to be used only to pay Contractor for the following enumerated reasons: (1) additional costs resulting from discrepancies in the bid buy-out process; (2) conflicts, discrepancies or errors in the Construction Documents; (3) work required by the Inspector of Record or any governmental agency involved in the permitting or approval/certification process that is not otherwise shown in the Construction Documents; and (4) any other items of cost agreed to in writing by the Contractor and District to be included in the Contractor Contingency. The Contractor Contingency shall not be used for costs incurred as a result of Contractor's acts, errors or omissions.

Contractor shall be responsible for tracking expenditures of the Contractor Contingency and shall provide periodic written updates to the District as directed. Unused Contractor Contingency and Allowances at Project completion will reduce the GMP and will result in an adjustment of the Tenant Improvement Payments and possibly the Sublease Payments.

The District shall at all times have the right to reduce the scope of the Project. If the District reduces the scope of the Project, the GMP shall be reduced commensurate with the reduced Scope of Work pursuant to the provisions of Section 10, below, and will result in an adjustment of the Tenant Improvement Payments and, if applicable, the Sublease Payments.

SECTION 6. NOTICE TO PROCEED WITH CONSTRUCTION

Upon receipt of an approved GMP, the District shall issue a notice to Contractor to proceed with the Construction of the Project. In the event that a Notice to Proceed with Construction is not issued for the Project, the Site Lease and the Sublease shall terminate upon written notice from the District to Contractor that a Notice of Proceed will not be issued.

SECTION 7. SAVINGS

If Contractor realizes a savings on one aspect of the Project, such savings shall be tracked and Contractor shall provide periodic written updates of such savings. Such savings shall be added to the Contractor Contingency and the use of such savings shall be as set forth in Section 5. However, if such savings are not so utilized, the amount of such savings shall reduce the GMP and will result in an adjustment of the Tenant Improvement Payments and, if applicable, the Sublease Payments.

SECTION 8. SELECTION OF SUBCONTRACTORS

In the interest of minimizing the expenditure of funds for the construction of the Project, Contractor agrees to select Subcontractors who are appropriately licensed by the State of California for each trade component of the Project in a manner that fosters competition. Contractor agrees that it will either solicit bids from potential subcontractors pursuant to the competitive bid procedures set forth in the California Public Contract Code, including specifically Public Contract Code section 20110, et seq., or that it will utilize an informal bidding process established by Contractor which also incorporates competitive bid procedures. Regardless of the method Contractor employs, Contractor will make a good faith effort to contact and utilize DVBE contractors and suppliers in securing bids for performance of the Project in accordance with the procedures set forth in Section 1.77 of the General Conditions. In the event that Contractor chooses to select Subcontractors pursuant to an informal bidding process, Contractor shall ensure that it receives at least three competitive quotes from potential subcontractors for each trade component of the Project, unless the parties agree otherwise on a trade-by-trade basis. The District reserves the right to oversee the bidding process. Contractor shall inform all bidders that the District will not be a party to any contracts for construction services executed by Contractor and selected bidders. Contractor shall submit a listing of proposed subcontractors to the District for the District's review. In no case, will Contractor award any sub-contracts until the District has concurred in the scope and price of the sub-contracted services. In addition, Contractor shall provide the District with full documentation regarding the bids or competitive quotes received by Contractor. In no event, shall such documentation be redacted or obliterated. In the event Contractor does not comply with this provision, the District may terminate this Agreement in accordance with the provisions of the General Conditions. Subcontractors awarded contracts by Contractor shall be afforded all the rights and protections of listed subcontractors under the provisions of the Subletting and Subcontracting Fair Practices Act (Public Contract Code Section 4100, et seq.).

SECTION 9. CONSTRUCTION SCOPE OF WORK

- A. Prior to commencing Construction, Contractor shall comply with the initial schedule requirements set forth in the General Conditions.
- B. Contractor shall complete the Construction pursuant to the Construction Documents as amended subject to any additional DSA or other regulatory approvals as may be required, performing all work set forth in the Scope of Work, and shall make reasonable efforts in scheduling to prevent disruption to classes.
- C. Contractor shall be responsible for complying with all applicable building codes, including without limitation mechanical codes, electrical codes, plumbing codes and fire codes, each of the latest edition, required by the regulatory agencies and for arranging and overseeing all necessary inspections and tests including inspections by

#17-117

the DSA or regulatory agencies, permits and occupancy permits, and ensuring compliance with any Federal and State laws, including, but not limited to, safety procedures and requirements, and construction employee training programs which cover among other items, hazardous chemicals and materials.

- D. Contractor shall establish procedures for the protection of all existing structures, equipment, utilities, and other existing improvements, both on-site and off-site. Contractor assumes all risk of loss of vandalism, theft of property or other property damage ("Vandalism") which occurs at a site at which Contractor is undertaking construction of the Project. Contractor assumes all risk of loss which occurs where Contractor is undertaking construction of the Project from causes due to negligence or misconduct by Contractor, its officers, employees, subcontractors, licensees and invitees. Contractor shall replace District property damaged by such Vandalism or theft or compensate the District for such loss, including payment of out of pocket expenses such as insurance deductibles the District might incur under such circumstances.
- E. Contractor shall develop a mutually agreed upon program with the District to abate and minimize noise, dust, and disruption to normal activities at the existing facilities at the School Facility, including procedures to control on-site noise, dust, and pollution during construction.
- F. The District shall cause the appropriate professionals to stamp and sign, as required, the original Construction Documents or parts thereof and coordinate the Project's design with all utilities.
- G. Contractor shall, for the benefit of the Subcontractors, attend pre-construction orientation conferences in conjunction with the Architect to set forth the various reporting procedures and site rules prior to the commencement of actual construction. Contractor shall also attend construction and progress meetings with District representatives and other interested parties, as requested by the District, to discuss such matters as procedures, progress problems and scheduling. Contractor shall prepare and promptly distribute official minutes of such meetings to all parties in attendance, including without limitation the District, the Architect and the District Inspector of Record.
- H. Contractor shall incorporate approved changes as they occur, and develop cash flow reports and forecasts for submittal to the District as requested. Contractor shall provide regular monitoring of the approved estimates for Construction costs, showing actual costs for activities in progress, and estimates for uncompleted tasks. Contractor shall maintain cost accounting records on authorized additional services or work performed under unit costs, additional work performed on the basis of actual costs of labor and materials, and for other work requiring accounting records.

- 8 -

#17-117

- I. Contractor shall record the progress of the Project and shall submit monthly written progress reports to the District and the Architect including information on the entire Project, showing percentages of completion and the number and amounts of proposed Extra Work/Modifications and their effect on the construction costs as of the date of each respective report.
- J. Contractor shall keep a log containing a record of weather, Subcontractors, work on the site, number of workers, work accomplished, problems encountered, and other similar relevant data as the District may require. Contractor shall make the log available to the District, the Architect, and the District's project manager. The District shall be promptly advised on all anticipated delays in the Project.
- K. The District shall bear the cost for the DSA Inspector, soils testing, DSA or other regulatory agency fees, and special testing required in the construction of the Project. If additional review or permits become necessary for reasons not due to Contractor's fault or because of DSA or regulatory agency requirements or regulations implemented after the date the Final GMP is established and not reasonably anticipated at the time the Final GMP is established, Contractor may seek additional compensation for the cost of that review as an additional cost. In the alternative, the District may pay such costs directly.

SECTION 10. EXTRA WORK/MODIFICATIONS

- A. The District may prescribe or approve additional work or a modification of requirements or of methods of performing the Construction which differ from the work or requirements set forth in the Construction Documents ("Extra Work/Modifications"); and for such purposes the District may at any time during the life of this Agreement, by written order, make such changes as it shall find necessary in the design, line, grade, form, location, dimensions, plan, or material of any part of the work or equipment specified in this Agreement or in the Construction Documents, or in the quantity or character of the work or equipment to be furnished. In the event conditions develop which, in the opinion of Contractor, makes strict compliance with the specifications impractical, Contractor shall notify the District of the need for Extra Work/Modifications by placing the matter on the agenda of regularly scheduled construction meetings with the District for discussion as soon as practicable after the need for the Extra Work/Modifications is determined. Additionally, Contractor shall submit to the District for its consideration and approval or disapproval, a written request for Extra Work/Modifications before such work is performed. If the District approves the request in writing, the costs of the Extra Work/Modification shall be added to or deducted from the GMP or the Scope of Work shall be modified to complete the Project within the

#17-117

GMP, as applicable. Any adjustments to the GMP will result in an adjustment of the Tenant Improvement Payment and, if applicable, the Sublease Payments.

- B. Extra Work/Modifications include work related to unforeseen underground conditions if, and only if, such conditions are not visible or identified on plans, reports or other documents available to Contractor. Extra Work/Modifications do not include underground conditions that are identified on plans, reports or other documents available to Contractor but are in a location different than is set forth on such plans, reports or other documents available to Contractor. It should be noted, however, that the District has advised and provided Contractor with information regarding the shallow water table and recent projects experience with encountering water when digging. Contractor has included in its calculation of the GMP an amount to mitigate for encountering water when completing the scope of work contemplated herein. Therefore, Extra Work/Modifications do not include expenses incurred by, and/or work performed by, Contractor in connection with such shallow water table and with encountering water when digging.
- C. Should Contractor claim that any instruction, request, drawing, specification, action, condition, omission, default or other situation (i) obligates the District to increase the GMP; or (ii) obligates the District to grant an extension of time for the completion of this Agreement; or (iii) constitutes a waiver of any provision in this Agreement, CONTRACTOR SHALL NOTIFY THE DISTRICT, IN WRITING, OF SUCH CLAIM AS SOON AS POSSIBLE, BUT IN NO EVENT WITHIN MORE THAN TEN (10) DAYS FROM THE DATE CONTRACTOR HAS ACTUAL OR CONSTRUCTIVE NOTICE OF THE CLAIM. CONTRACTOR SHALL ALSO PROVIDE THE DISTRICT WITH SUFFICIENT WRITTEN DOCUMENTATION SUPPORTING THE FACTUAL BASIS OF THE CLAIM including items used in valuing said claim. Contractor shall be required to certify under penalty of perjury the validity and accuracy of any claims submitted. Contractor's failure to notify the District within such ten (10) day period shall be deemed a waiver and relinquishment of the claim against the District.
- D. Expenses of reconstruction and/or costs to replace and/or repair damaged materials and supplies, provided that Contractor is not fully compensated for such expenses and/or costs by insurance or otherwise, shall be included in an increase to the GMP if said expenses are the result of the negligent acts or omissions of the District, or its principals, agents, servants, or employees.

SECTION 11. NOT USED

SECTION 12. PERSONNEL ASSIGNMENT

- A. Contractor shall assign **Carl Magness** as Project Manager/Superintendent for the Project. So long as **Carl Magness** remains in the employ of Contractor, such person shall not be changed or substituted from the Project, or cease to be fully committed to the Project except as provided in this Section. In the event Contractor deems it necessary, Contractor shall replace the manager and/or the superintendent for the Project with a replacement with like qualifications and experience, subject to the prior written consent of the District, which consent shall not be unreasonably withheld. Any violation of the terms of paragraph A of this Section 12 shall entitle the District to terminate this Agreement for breach, pursuant to the provisions of the General Conditions.
- B. Notwithstanding the foregoing provisions of paragraph A of Section 12, above, if any manager and/or superintendent proves not to be satisfactory to the District, upon written notice from the District to Contractor, such person(s) shall be promptly replaced by a person who is acceptable to the District in accordance with the following procedures: Within five (5) business days after receipt of a notice from the District requesting replacement of any manager and/or superintendent or discovery by Contractor that any manager and/or superintendent is leaving their employ, as the case may be, Contractor shall provide the District with the name of an acceptable replacement/substitution together with such information as the District may reasonably request about such replacement/substitution. The replacement/substitution shall commence work on the Project no later than five (5) business days following the District's approval of such replacement, which approval shall not be unreasonably withheld. If the District and Contractor cannot agree as to the replacement/substitution, the District shall be entitled to terminate this Agreement for breach pursuant to the provisions of the General Conditions.

SECTION 13. BONDING REQUIREMENTS

Contractor shall fully comply with the requirements set forth in Section 6.9 of the General Conditions.

SECTION 14. PAYMENTS TO CONTRACTOR

- A. Contractor shall finance the cost of construction of the Project which costs shall not exceed the GMP, which shall not be adjusted except as otherwise provided in this Agreement. The District shall pay Contractor Tenant Improvement Payments and Sublease Payments pursuant to the terms and conditions of Section 6 of the Sublease. In the event of a dispute between the District and Contractor, the District may withhold from the Tenant Improvement Payments and the Sublease Payments an amount not to exceed one hundred fifty percent (150%) of the disputed amount.

- B. This Agreement is subject to the provisions of California Public Contract Code Sections 7107, 7201 and 20104.50 as they may from time to time be amended.
- C. For purposes of this Agreement, the acceptance by the District means acceptance made only by an action of the governing body of the District in session. Acceptance by Contractor of the final Tenant Improvement Payment or the Sublease Payment, as the case may be, shall constitute a waiver of all claims against the District related to those amounts.

SECTION 15. CONTRACTOR'S CONTINUING RESPONSIBILITY

Neither the final payment nor any provision in the Contract Documents shall relieve Contractor of responsibility for faulty materials or workmanship incorporated in the Project or for any failure to comply with the requirements of the Contract Documents.

SECTION 16. INSURANCE

Contractor shall provide, during the life of this Agreement, the types and amounts of insurance set forth in Article 6 of the General Conditions, which are incorporated by reference herein.

SECTION 17. USE OF PREMISES

Contractor shall confine operations at the Site to areas permitted by law, ordinances, permits and the Construction Documents and shall not unreasonably encumber the Site or existing School Facilities at the Site with any materials or equipment. Contractor shall not load or permit any part of the work to be loaded with a weight so as to endanger the safety of persons or property at the Site.

SECTION 18. SITE REPRESENTATIONS

The District warrants and represents that the District has, and will continue to retain at all times during the course of construction, legal title to the Site and that said land is properly subdivided and zoned so as to permit the construction and use of said Site with respect to the Project. The District further warrants and represents that title to said land is free of any easements, conditions, limitation, special permits, variances, agreements or restrictions which would prevent, limit or otherwise restrict the construction or use of said Site pursuant to this Agreement. Reference is made to the fact that the District has provided information on the Site to Contractor. Such information shall not relieve Contractor of its responsibility; and the interpretation of such data regarding the Site, as disclosed by any borings or other preliminary investigations, is not warranted or guaranteed, either expressly or implicitly, by the District. Contractor shall be responsible for having ascertained pertinent local conditions such as location,

#17-117

accessibility and general character of the Site and for having satisfied itself as to the conditions under which the work is to be performed. No claim for any allowances because of Contractor's error or negligence in acquainting itself with the conditions at the Site will be recognized.

SECTION 19. HAZARDOUS WASTE AND UNKNOWN PHYSICAL CONDITIONS

Contractor shall comply with the District's Hazardous Materials Procedures and Requirements as set forth herein.

- A. If the District has identified the presence of hazardous materials on or in proximity to the Site (the "Pre-existing Hazardous Materials"), Contractor shall review all information provided by the District that characterizes the Pre-existing Hazardous Materials and shall take the actions approved by DTSC and issued by the District necessary to address the Pre-existing Hazardous Materials in the performance of the work. Contractor shall conduct the work based on this information issued at the time contract documents are executed. Contractor shall immediately communicate, in writing, any variances from available information to the District.
- B. The District will retain an additional independent environmental consultant to perform the investigation, inspection, testing, assessment, sampling and analysis necessary to prepare and recommend a remediation plan for the Pre-existing Hazardous Materials for the District's approval (the "Remediation Plan").
- C. The District will retain title to all Pre-existing Hazardous Materials encountered during the work. This does not include hazardous material generated by Contractor, including but not limited to used motor oils, lubricants, cleaners, etc. Contractor shall dispose of such hazardous waste in accordance with the provisions of the Contract Documents, as well as local, State and Federal laws and regulations. The District will be shown as the hazardous waste generator and will sign all hazardous waste shipment manifests for non-Contractor generated hazardous waste. Nothing contained within these Contract Documents shall be construed or interpreted as requiring Contractor to assume the status of owner or generator of hazardous waste substances for non-Contractor generated hazardous wastes.
- D. Except as otherwise provided herein, it is the responsibility of Contractor to obtain governmental approvals relating to Hazardous Materials Management, including Federal and State surface water and groundwater discharge permits and permits for recycling and reuse of hazardous materials for all work noted in the contract documents. Contractor shall be responsible for coordinating compliance with such governmental approvals and applicable governmental rules with the District's hazardous materials consultant, including those governing the preparation of waste profiles, waste manifests, and bills of lading. If Contractor encounters hazardous materials, it shall immediately notify the District in writing. The District, Consultant and

- 13 -

#17-117

Contractor shall jointly establish the plan for disposition and actions to be taken with respect to the hazardous materials, subject to final written approval by the District.

E. If, during construction, Contractor encounters materials, conditions, waste, contaminated groundwater or substances, not identified in the District's assessment report, that Contractor reasonably suspects are hazardous materials, Contractor shall stop the affected portion of the work, secure the area, promptly notify the District, and take reasonable measures to mitigate the impact of such work stoppage. The District shall retain the services of an environmental consultant to perform investigation, inspection, testing, assessment, sampling and analysis of the suspect materials, conditions, waste, groundwater or substances.

(1) Found Not to be Hazardous Materials. If the environmental consultant determines that the materials, conditions, waste, contaminated groundwater or substances do not constitute hazardous materials, Contractor shall recommence the suspended work.

(2) Found to be Hazardous Materials. If the environmental consultant determines that the materials, conditions, waste, contaminated groundwater or substances constitute hazardous materials and such hazardous materials require remediation and disposal, then the District, Consultant and Contractor shall jointly establish the plan for disposition and actions to be taken with respect to the hazardous materials, subject to final written approval by the District. All such costs shall be the responsibility of the District.

F. Exacerbation of Pre-Existing Hazardous Materials.

If during construction Contractor encounters pre-existing environmental conditions that it knew or should have known involve hazardous materials (the "Point of Discovery") (which encounters may include an unavoidable release or releases of hazardous materials) then Contractor must immediately stop the affected portion of the work. If Contractor fails to immediately stop the affected portion of the work after the Point of Discovery, then Contractor is solely responsible for any resultant Exacerbation Cost. "Exacerbate," in all its forms, means the worsening effects of Contractor's failure to stop the affected portion of work after the Point of Discovery. "Exacerbation Cost" means the differential between (i) the actual increase in the cost of remediation and delays to the Project attributable to pre-existing environmental conditions involving hazardous substances, and (ii) the cost thereof or delays thereto had Contractor immediately stopped the affected portion of the work after the Point of Discovery. The standard of "should have known" applies to Contractor's supervisory personnel, whether or not on the Site. Contractor's supervisory personnel must have had the hazardous material training required by applicable OSHA and Cal OSHA rules or regulations.

- 14 -

SECTION 20. INDEPENDENT CONTRACTOR

- A. Contractor is retained as an independent contractor and is not employed by the District. No employee or agent of Contractor shall become, or be considered to be, an employee of the District for any purpose. It is agreed that the District is interested only in the results obtained from service under this Agreement and that Contractor shall perform as an independent contractor with sole control of the manner and means of performing the services required under this Agreement. Contractor shall complete this Agreement according to its own methods of work which shall be in the exclusive charge and control of Contractor and which shall not be subject to control or supervision by the District except as to results of the work. It is expressly understood and agreed that Contractor and its employees shall in no event be entitled to any benefits to which the District employees are entitled, including, but not limited to, overtime, retirement benefits, insurance, vacation, worker's compensation benefits, sick or injury leave or other benefits.
- B. Contractor shall be responsible for all salaries, payments, and benefits for all of its officers, agents, and employees in performing services pursuant to this Agreement.

SECTION 21. ACCOUNTING RECORDS

Contractor, and all Subcontractors, shall check all materials, equipment and labor entering into the work and shall keep or cause to be kept such full and detailed accounts as may be necessary for proper financial management under this Agreement, including true and complete books, records and accounts of all financial transactions in the course of their activities and operations related to the Project. These documents include sales slips, invoices, payrolls, personnel records, requests for Subcontractor payment, and other data relating to all matters covered by the Contract Documents (the "Data"). The Data shall be maintained for ten (10) years from the latest expiration of the term (as such may be extended) of any of the Contract Documents. Contractor shall use its best efforts to cause its Subcontractors to keep or cause to be kept true and complete books, records and accounts of all financial transactions in the course of its activities and operations related to the Project. Upon completion of the Project, Contractor shall provide the District with one (1) complete copy of the Data.

The District, at its own costs, shall have the right to review and audit, upon reasonable notice, the books and records of Contractor and any Subcontractors concerning any monies associated with the Project.

SECTION 22. PERSONAL LIABILITY

Neither the trustees, officers, employees, or agents of District, the District's representative, or Architect shall be personally responsible for any liability arising under the Contract Documents.

SECTION 23. AGREEMENT MODIFICATIONS

No waiver, alteration or modification of any of the provisions of this Agreement shall be binding upon either the District or Contractor unless the same shall be in writing and signed by both the District and Contractor.

SECTION 24. NOTICES

Any notices or filings required to be given or made under this Agreement shall be served, given or made in writing upon the District or Contractor, as the case may be, by personal delivery or registered mail (with a copy sent via fax or regular mail) to the respective addresses given below or at such other address as such party may provide in accordance with the provisions herein. Any change in the addresses noted herein shall not be binding upon the other party unless preceded by no less than thirty (30) days prior written notice.

If to Contractor:

Bernards
555 First Street
San Fernando, CA 91340
Attn: Rick Fochtman

If to the District:

Oxnard School District
1051 South A Street
Oxnard, California 93030
Attn: Dr. Cesar Morales, Superintendent

With a copy to Nitasha Sawhney,
Garcia, Hernandez, Sawhney & Bermudez LLP
2490 Mariner Square Loop, Suite 140
Alameda, CA 94501

And with an additional copy to Scott Burkett,
Caldwell Flores Winters, Inc.
6425 Christie Ave., Suite 270
Emeryville, CA 94608

Notices under this Agreement shall be deemed to have been given, and shall be effective upon actual receipt by the other parties, or, if mailed, upon the earlier of the fifth (5th) day after mailing or actual receipt by the other party.

SECTION 25. ASSIGNMENT

Neither party to this Agreement shall assign this Agreement or sublet it as a whole without the written consent of the other, nor shall Contractor assign any monies due or to become due to it hereunder without the prior written consent of the District.

SECTION 26. PROVISIONS REQUIRED BY LAW

Each and every provision of law and clause required to be inserted in these Contract Documents shall be deemed to be inserted herein and the Contract Documents shall be read and enforced as though it were included herein, and if through mistake or otherwise any such provision is not inserted or is not inserted correctly, then upon application of either party the Contract Documents shall forthwith be physically amended to make such insertion or correction.

SECTION 27. HEADINGS

The headings in this Agreement are inserted only as a matter of convenience and reference and are not meant to define, limit or describe the scope or intent of the Contract Documents or in any way to affect the terms and provisions set forth herein.

SECTION 28. APPLICABLE LAW

This Agreement shall be governed by and construed in accordance with the laws of the State of California. The parties irrevocably agree that any action, suit or proceeding by or among the District and Contractor shall be brought in whichever of the Superior Courts of the State of California, Ventura County, or the Federal Court for the Central District of California in Los Angeles, California, has subject matter jurisdiction over the dispute and waive any objection that they may now or hereafter have regarding the choice of forum whether on personal jurisdiction, venue, forum non conveniens or on any other ground.

SECTION 29. SUCCESSION OF RIGHTS AND OBLIGATIONS

All rights and obligations under this Agreement shall inure to and be binding upon the successors and assigns of the parties hereto.

SECTION 30. NOTIFICATION OF THIRD PARTY CLAIMS

The District shall provide Contractor with timely notification of the receipt by the District of any third-party claim relating to this Agreement, and the District may charge back to Contractor the cost of any such notification.

SECTION 31. SEVERABILITY

If any one or more of the terms, covenants or conditions of this Agreement shall to any extent be declared invalid, unenforceable, void or voidable for any reason whatsoever by a court of competent jurisdiction, the finding or order or decree of which becomes final, none of the remaining terms, provisions, covenants and conditions of the Contract Documents shall be affected thereby, and each provision of the Contract Documents shall be valid and enforceable to the fullest extent permitted by law.

SECTION 32. ENTIRE AGREEMENT

This Construction Services Agreement and the additional Contract Documents as defined in paragraph C of Section 1 herein, including the Site Lease, the Sublease, and the Specifications, drawings, and plans constitute the entire agreement between Contractor and the District. The Contract Documents shall not be amended, altered, changed, modified or terminated without the written consent of both parties hereto, except as otherwise provided in Section 10 hereof.

SECTION 33. EXECUTION IN COUNTERPARTS

This Agreement may be executed in any number of counterparts, each of which shall be an original, but all of which together shall constitute one instrument.

IN WITNESS, WHEREOF the parties hereto, intending to be legally bound thereby, have executed this Agreement effective as of the date first above written.

CONTRACTOR

Bernards
By: Rick Fochtman

By: Rick Falt

Title: Executive Vice President

Date: 8/29/2017

THE DISTRICT

Oxnard School District,
a California school district
By: Lisa A. Franz, Director, Purchasing

By: Lisa A. Franz

Title: Director, Purchasing

Date: 9-7-17

#17-117

EXHIBIT A

Scope of Work (Plans & Specifications)

Marshall New Classroom Building

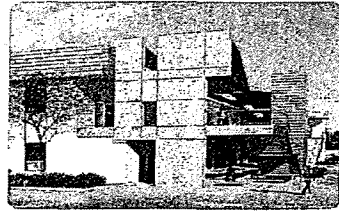
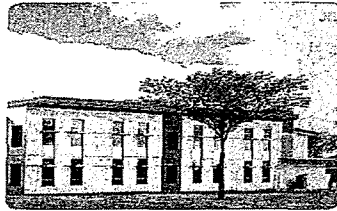
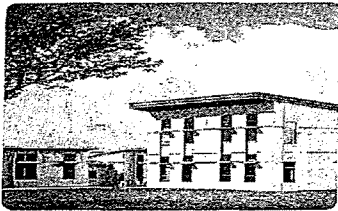

100% Construction Documents Package

Oxnard School District

October 4, 2016

*LFEB. 17. 2017
DFA A# 03 - 114806*

BINDER A

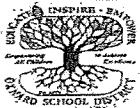

Oxnard School District
Marshall New Classroom Building
2900 Thurgood Marshall Dr. Oxnard, CA 93036

CSDA | DESIGN GROUP

#17-117

EXHIBIT A, continued

BIDDING DOCUMENTS TABLE OF CONTENTS

VOLUME 1 of 2 (Not submitted to DSA)

DIVISION 00 - PROCUREMENT AND CONTRACTING REQUIREMENTS

| | |
|---------|--|
| 00 2150 | List of Subcontractors |
| 00 2400 | Statement of Bidder's Qualifications |
| 00 2600 | Bid Bond |
| 00 4000 | Labor and Material Payment Bond |
| 00 4100 | Performance Bond |
| 00 4150 | Certificate of Worker's Compensation Insurance |
| 00 5100 | Background Check and Fingerprinting Procedures for Contractors |
| 00 5300 | Guarantee and Standard Forms |
| 00 7000 | General Conditions |

DIVISION 1 -- 2 (Not Used)

Volume 2 of 2

DIVISION 03 - CONCRETE

| | |
|---------|------------------------------|
| 03 1000 | Concrete Forming Accessories |
| 03 2000 | Concrete Reinforcing |
| 03 3000 | Cast-In-Place Concrete |

DIVISION 04 - MASONRY

| | |
|---------|-----------------------|
| 04 2200 | Concrete Unit Masonry |
|---------|-----------------------|

DIVISION 05 - METALS

| | |
|---------|--------------------------|
| 05 1200 | Structural Steel Framing |
| 05 5000 | Metal Fabrications |

DIVISION 06 - WOOD, PLASTICS, AND COMPOSITES

| | |
|---------|------------------------|
| 06 1000 | Rough Carpentry |
| 06 1733 | Wood I-Joists |
| 06 1813 | Glued Laminated Beams |
| 06 4000 | Architectural Woodwork |

TABLE OF CONTENTS

MARSHALL NEW CLASSROOM BUILDING

- 20 -

OXNARD SCHOOL DISTRICT

CONSTRUCTION SERVICES AGREEMENT

Marshall New Classroom Building Project

August 24th, 2017

#17-117

EXHIBIT A, continued

DIVISION 07 - THERMAL AND MOISTURE PROTECTION

07 1326 Self Adhering Sheet Wang
07 2100 Thermal Insulation
074000 Metal Roof Panels
075416 Polyvinyl Chloride (PVC) Roofing
076000 Flashing Sheet Metal
078400 Fire Stop and Smoke Seals
079200 Joint Sealants

DIVISION 08 - OPENINGS

08 1113 Hollow Metal Doors and Frames
08 1416 Flush Wood Doors
08 3116 Access Panels and Frames
08 3613 Sectional Doors
08 5113 Aluminum Windows
08 7100 Door Hardware
08 8000 Glazing

DIVISION 09 - FINISHES

09 2200 Cement Plastering
09 2900 Gypsum Board
09 3013 Ceramic Tiling
09 5123 Acoustical Tile Ceilings
09 6513 Rubber Base
09 6519 Resilient Tile Flooring
09 9000 Paints and Coatings

DIVISION 10 - SPECIALTIES

101400 Signage
102113.17 Phenolic-Core Shower and Dressing Compartments
102800 Toilet Accessories
105200 Fire Extinguishers

DIVISION 11 - EQUIPMENT

116800 Playfield Equipment and Structures

TABLE OF CONTENTS

MARSHALL NEW CLASSROOM BUILDING

- 21 -

OXNARD SCHOOL DISTRICT

CONSTRUCTION SERVICES AGREEMENT

Marshall New Classroom Building Project

August 24th, 2017

EXHIBIT A, continued



DIVISION 12 - FURNISHINGS

- 12 2413 Roller Window Shades
- 12 3553 Manufactured Plastic-Laminate-Faced Casework

DIVISION 13 (Not Used)

DIVISION 14 - CONVEYING EQUIPMENT

- 14 2123 Machine-Room-Less Electric Traction Passenger Elevators

DIVISION 15 – 20 (Not Used)

DIVISION 21 - FIRE SUPPRESSION

- 21 1000 Fire Protection

DIVISION 22 – PLUMBING



- 22 0500 Basic Materials and Methods
- 22 0553 Identification
- 22 0700 Insulation
- 22 0800 Equipment and Systems Tests
- 22 1100 Domestic and Industrial Water Systems
- 22 1300 Drainage System
- 22 4000 Plumbing Fixtures

DIVISION 23 – HEATING, VENTILATION, AND AIR CONDITIONING (HVAC)

- 23 0000 General Provisions
- 23 0513 Electric Motors and Controllers
- 23 0548 Vibration Isolation and Seismic Restraints
- 23 2500 Water Treatment
- 23 3100 Air Transmission and Distribution System
- 23 8000 Air Conditioning and Air Handling Equipment
- 23 9000 Building Management System

DIVISION 24 – 25 (Not Used)



DIVISION 26 - ELECTRICAL

- 26 0126 Inspection Test and Acceptance

TABLE OF CONTENTS
MARSHALL NEW CLASSROOM BUILDING

EXHIBIT A, continued

- 26 0500 Common Work Results for Electrical
- 26 0513 Basic Electrical Materials and Methods
- 26 0519 Low-Voltage Wires (600 Volt AC)
- 26 0526 Grounding and Bonding
- 26 0533 Raceways and Boxes Fitting and Supports
- 26 0586 Motors and Drives
- 26 0800 Electrical Systems Commissioning
- 26 0923 Lighting Control Systems
- 26 1000 Service Entrance
- 26 2200 Low-Voltage Transformers
- 26 2413 Switchboards1000
- 26 2416 Panelboards and Signal Terminal Cabinets
- 26 2419 Motor Control Devices
- 26 5000 Lighting
- 26 5200 Emergency Power Systems

DIVISION 27 - COMMUNICATIONS

- 27 0126 Test and Acceptance Requirements for Structured Cabling
- 27 1013 Structured Cabling
- 27 4113 Classroom Sound Enhancement System
- 27 5116 Public Address and Intercommunication Systems
- 27 5313 Clock and Program Systems

DIVISION 28 – ELECTRONIC SAFETY AND SECURITY

- 28 1600 Intrusion Detection System
- 28 3100 Fire Detection and Alarm System

DIVISION 29 – 30 (Not Used)

DIVISION 31 – EARTHWORK

- 31 1000 Site Clearing
- 31 2200 Grading
- 31 2316 Excavation and Fill Paving
- 31 2319 Excavation and Fill Structures
- 31 2323 Excavation and Fill Utilities
- 31 2326 Base Course

TABLE OF CONTENTS

MARSHALL NEW CLASSROOM BUILDING

#17-117

EXHIBIT A, continued

DIVISION 32 – EXTERIOR IMPROVEMENTS



| | |
|---------|-------------------------------|
| 32 0117 | Pavement Repair |
| 32 1216 | Asphalt Paving |
| 32 1236 | Seal for Bituminous Surfacing |
| 32 1313 | Site Concrete Work |

DIVISION 33 – SITE IMPROVEMENTS

| | |
|---------|-----------------------------------|
| 33 1100 | Site Water Distribution Utilities |
| 33 3000 | Site Sanitary Sewer Utilities |
| 33 4000 | Storm Drainage Utilities |



TABLE OF CONTENTS
MARSHALL NEW CLASSROOM BUILDING

- 24 -

OXNARD SCHOOL DISTRICT

CONSTRUCTION SERVICES AGREEMENT

Marshall New Classroom Building Project

August 24th, 2017

EXHIBIT A, continued

| | |
|--|--------------------------------------|
| <p>100% DISTRICT SUBMITTAL MARSHALL NEW CLASSROOM BUILDING <small>2950 THURGOOD MARSHALL DR. OXNARD, CA 93036</small> OXNARD SCHOOL DISTRICT</p> | <p>VOLUME I</p> |
| <p>DSA FILE NO. 56-22</p> | <p>DSA APPLICATION NO. 03-116806</p> |
| <p>PTN NO. 72538-91</p> | |

DRAWING INDEX

| VOLUME I | VOLUME II | |
|--|---|---|
| <p>01- GENERAL</p> <p>G-001 COVER SHEET, INDEX, SCOPE OF WORK, VICINITY MAP G-002 GENERAL NOTES, ABBREVIATIONS, SYMBOL LEGEND</p> <p>G-003 FIRE LIFE SAFETY SITE PLAN G-004 ACCESSIBILITY SITE PLAN G-005 BUILDING CODE ANALYSIS G-006 SIGNAGE & FIRE EXTINGUISHER PLANS</p> <p>6</p> <p>03-CIVIL</p> <p>C-001 GENERAL NOTES C-002 LEGEND AND ABBREVIATIONS C-101 DEMOLITION PLAN C-102 DEMOLITION PLAN C-103 DEMOLITION PLAN C-201 SITE CONTROL PLAN C-202 SITE CONTROL PLAN C-203 SITE CONTROL PLAN C-204 STRIPING PLAN C-300 COMPOSITE GRADING PLAN C-301 ENLARGED GRADING PLAN C-302 ENLARGED GRADING PLAN C-303 GRADING SECTIONS C-304 GRADING SECTIONS C-401 SITE UTILITY PLAN C-402 SITE UTILITY PLAN C-403 SITE UTILITY PROFILE C-404 SITE UTILITY PROFILE C-701 MISCELLANEOUS DETAILS C-702 MISCELLANEOUS DETAILS C-703 MISCELLANEOUS DETAILS C-704 MISCELLANEOUS DETAILS</p> <p>22</p> <p>04- LANDSCAPE</p> <p>L-1 IRRIGATION PLAN L-2 PLANTING PLAN L-3 IRRIGATION & PLANTING DETAILS L-4 IRRIGATION & PLANTING SPECIFICATIONS</p> <p>4</p> <p>05- STRUCTURAL</p> <p>S-101 GENERAL NOTES S-101A GENERAL NOTES & ABBREVIATIONS S-211 FOUNDATION PLAN S-212 2ND FLOOR FRAMING PLAN S-213 ROOF FRAMING PLAN S-214 CANOPY ROOF FRAMING PLAN S-400 TYPICAL CONCRETE DETAILS S-400A TYPICAL CONCRETE DETAILS S-401 FOUNDATION DETAILS S-600 TYPICAL WOOD DETAILS S-600A TYPICAL WOOD DETAILS S-600B TYPICAL WOOD DETAILS S-600C TYPICAL WOOD DETAILS S-600D TYPICAL WOOD DETAILS S-800E WALL ELEVATION AND DETAILS S-800F WALL ELEVATION AND DETAILS S-700 FRAMING DETAILS S-700A ELEVATOR DETAILS S-700B STAIR PLANS & DETAILS</p> <p>19</p> | <p>06- ARCHITECTURAL</p> <p>A-101 SITE PLAN A-102 ENLARGED SITE PLAN A-103 ENLARGED SITE PLAN A-104 SITE DETAILS A-105 SITE DETAILS</p> <p>A-111 FIRST FLOOR PLAN A-112 SECOND FLOOR PLAN</p> <p>A-121 FIRST FLOOR REFLECTED CEILING PLAN A-122 SECOND FLOOR REFLECTED CEILING PLAN</p> <p>A-131 ROOF PLAN</p> <p>A-210 EXTERIOR ELEVATIONS A-211 EXTERIOR ELEVATIONS</p> <p>A-220 INTERIOR ELEVATIONS A-221 INTERIOR ELEVATIONS A-222 INTERIOR ELEVATIONS A-223 INTERIOR ELEVATIONS A-224 TOILET INTERIOR ELEVATIONS</p> <p>A-310 BUILDING SECTIONS A-311 BUILDING SECTIONS</p> <p>A-320 WALL SECTIONS A-321 WALL SECTIONS A-322 WALL SECTIONS</p> <p>A-410 ENLARGED FLOOR PLANS A-411 ENLARGED FLOOR PLANS</p> <p>A-420 VERTICAL CIRCULATION PLANS & SECTIONS A-421 VERTICAL CIRCULATION PLANS & SECTIONS</p> <p>A-600 ROOF DETAILS A-601 ROOF DETAILS</p> <p>A-610 EXTERIOR ENVELOPE DETAILS</p> <p>A-620 WINDOW/DOOR DETAILS A-621 DOOR DETAILS</p> <p>A-630 INTERIOR DETAILS A-631 INTERIOR DETAILS A-635 TOILET DETAILS</p> <p>A-640 CEILING DETAILS</p> <p>A-650 SIGNAGE DETAILS</p> <p>A-660 STAIR DETAILS A-661 ELEVATOR DETAILS</p> <p>A-670 CASEWORK DETAILS</p> <p>A-610 DOOR SCHEDULE A-612 FINISH SCHEDULE</p> <p>A-620 WALL TYPES</p> <p>27</p> | <p>E-041 PANEL SCHEDULES E-050 ELECTRICAL DETAILS E-090 SIGNAL SYSTEM RISER DIAGRAMS E-101 SITE PLAN - ELECTRICAL E-102 ENLARGED SITE PLAN - ELECTRICAL E-201 FIRST FLOOR PLAN - LIGHTING E-202 FIRST FLOOR PLAN - POWER E-203 FIRST FLOOR PLAN - SIGNAL E-204 FIRST FLOOR PLAN - FIRE ALARM E-301 SECOND FLOOR PLAN - LIGHTING E-302 SECOND FLOOR PLAN - POWER E-303 SECOND FLOOR PLAN - SIGNAL E-304 SECOND FLOOR PLAN - FIRE ALARM E-401 ROOF PLAN - ELECTRICAL</p> <p>29</p> <p>10- PLUMBING</p> <p>P-001 LEGENDS, NOTES, AND SCHEDULES P-101 PLUMBING SITE PLAN P-111 FIRST FLOOR PLAN P-112 SECOND FLOOR PLAN P-131 ROOF PLAN P-411 ENLARGED FLOOR PLAN P-611 PLUMBING DETAILS</p> <p>7</p> <p>11- FIRE PROTECTION</p> <p>FP-001 SITE PLAN & NOTES FP-002 FIRST FLOOR PLAN FP-003 SECOND FLOOR PLAN FP-004 BUILDING SECTIONS FP-005 MISCELLANEOUS DETAILS</p> <p>6</p> <p>Grand total: 140</p> |

EXHIBIT A, continued

19
Volume I total: 51

| A - 001 WALL TYPES | |
|--------------------|--|
| 42 | |
| 08-MECHANICAL | |
| M-001 | LEGENDS, NOTES, AND SCHEDULES |
| M-111 | FIRST FLOOR PLAN |
| M-112 | SECOND FLOOR PLAN |
| M-131 | ROOF PLAN |
| M-510 | MECHANICAL DETAILS |
| M-521 | VIBRATION ISOLATOR DETAILS |
| M-601 | ENERGY COMPLIANCE FORMS |
| M-602 | ENERGY COMPLIANCE FORMS |
| M-603 | ENERGY COMPLIANCE FORMS |
| 9 | |
| 09-ELECTRICAL | |
| E-001 | SYMBOL LIST, ABBREVIATIONS & NOTES |
| E-002 | GENERAL ELECTRICAL NOTES |
| E-010 | FIXTURE LIST & TITLE 24 CALCULATIONS |
| E-011 | TITLE 24 CALCULATIONS - INDOOR LIGHTING |
| E-012 | TITLE 24 CALCULATIONS - OUTDOOR LIGHTING |
| E-013 | TITLE 24 CALCULATIONS - INDOOR LIGHTING |
| E-014 | TITLE 24 CALCULATIONS - OUTDOOR LIGHTING |
| E-015 | LIGHTING CONTROL INFORMATION |
| E-016 | LIGHTING CONTROL INFORMATION |
| E-020 | FIRE ALARM INFORMATION |
| E-021 | FIRE ALARM CALCULATIONS |
| E-022 | FIRE ALARM RISER DIAGRAM |
| E-030 | SINGLE LINE DIAGRAM |
| E-031 | SWITCHBOARD ELEVATIONS |
| E-040 | PANEL SCHEDULES |

Exhibit B

Guaranteed Maximum Price (GMP)



SCHEDULE OF VALUES

Marshall Classroom Building
 Oxnard School District
 2900 Thurgood Marshall Dr, Oxnard, CA 93036

GMP
 July 20, 2017

| | Description | Recommended Subcontractor | Amount |
|-------|--|----------------------------------|-----------------|
| 01570 | Erosion Control | Socal Stormwater Runoff Solution | 78,677 |
| 01730 | Surveying | Michael Baker International | 20,900 |
| 03200 | Reinforcing Steel | Vista Steel | 96,970 |
| 03300 | Cast In Place Concrete | Santa Clarita Concrete | 413,131 |
| 05120 | Structural Steel & Misc. Metals | C.A. Buchen | 294,133 |
| 05700 | Ornamental Metals | | w/ Struct Steel |
| 06100 | Rough Carpentry | JF Construction | 1,067,965 |
| 06200 | Millwork / Cabinetry / Countertops | Dennis Reeves Inc. | 34,161 |
| 07140 | Waterproofing / Traffic Coating | Systems WP | 63,636 |
| 07200 | Insulation | Alcal | 47,851 |
| 07540 | Roofing | Best Contracting | 118,535 |
| 07600 | Sheet Metal / Metal Roofing | Merit Metal Products | 160,900 |
| 08100 | Doors / Frames / Hardware | Construction Hardware | 110,110 |
| 08800 | Glass and Glazing | Santa Barbara Glass | 114,087 |
| 09220 | Plaster & Drywall | Church and Larsen | 538,346 |
| 09300 | Ceramic Tile | Silverado Tile | 51,120 |
| 09510 | Acoustical Ceilings & Wall Panels | Prime Acoustics | 48,320 |
| 09650 | Resilient Flooring and Carpet | Reliable Flooring | 69,611 |
| 09900 | Painting | Vanguard | 102,192 |
| 10000 | Building Specialties | Various | 55,645 |
| 10110 | Visual Display Boards | Nelson Adams Naco Inc. | 148,359 |
| 10140 | Signage | AGS | 12,625 |
| 10280 | Toilet Partitions / Bathroom Accessories | YTI Enterprises | 29,000 |
| 12240 | Window Shades | A1 Quality Blinds | 10,000 |
| | Final Cleaning | Commercial Const Cleaning | 26,050 |
| 14200 | Elevators | Republic Elevator | 90,220 |
| 21000 | Fire Sprinkler | J.G. Tate Fire Protection | 143,456 |
| 22000 | Plumbing | City Commerical | 355,312 |
| 23000 | HVAC | Sheldon Mechanical | 366,968 |
| 26000 | Electrical / Low Voltage | Taft Electric | 1,177,480 |
| 31220 | Demo, Earthwork and Site Clearing | Damar Const. | 176,464 |
| 32122 | Asphalt Paving | Onyx Paving | 48,580 |
| 32131 | Site Concrete | B&M Contractors | 147,475 |
| 32800 | Playground Surfaces & Equipment | SpectraTurf / Miracle Playground | 100,262 |
| 32900 | Landscape and Irrigation | Dufau Landscape | 81,345 |



SCHEDULE OF VALUES

Marshall Classroom Building
 Oxnard School District
 2900 Thurgood Marshall Dr, Oxnard, CA 93036

GMP
 July 20, 2017

| Description | | Recommended Subcontractor | Amount |
|-------------|----------------|---------------------------|---------|
| 33000 | Site Utilities | Sam Hill & Sons | 210,055 |
| 01000 | Allowances | | 85,000 |
| | Subguard | 1.20% | 80,339 |

| | | | |
|-----------------------------------|--|--|---------------------|
| Subcontracted Direct Costs | | | \$ 6,775,280 |
|-----------------------------------|--|--|---------------------|

| | | | |
|--|----------------------|--|------------------|
| | General Conditions | | 1,287,702 |
| | General Requirements | | 3,250 |
| | Subtotal | | 8,066,232 |

| | | | |
|--|---|-------|------------------|
| | Contractor Controlled Insurance Program | 1.25% | 100,828 |
| | Builders Risk Insurance | | By Owner |
| | General Contractor Bond | 0.85% | 69,420 |
| | Subtotal | | 8,236,479 |

| | | | |
|--|-----------------|-------|------------------|
| | Contractor Fee | 5.00% | 411,824 |
| | Subtotal | | 8,648,303 |

| | | | |
|--|------------------------|-------|---------|
| | Contractor Contingency | 4.00% | 345,932 |
|--|------------------------|-------|---------|

| | | | |
|------------------------------|--|--|---------------------|
| Total Contract Amount | | | \$ 8,994,236 |
|------------------------------|--|--|---------------------|



ALLOWANCES

Marshall Classroom Building

Oxnard School District

2900 Thurgood Marshall Dr, Oxnard, CA 93036

GMP

July 20, 2017

| Allowances Included in Proposal | | |
|---------------------------------|--|------------------|
| 1 | Natural gas service line. | \$ 50,000 |
| 2 | Furnish and install new Gate G assembly including hardware | \$ 10,000 |
| 3 | Temporary power during SCE electrical service switch-over in Summer of 2018. | \$ 25,000 |
| TOTAL ALLOWANCES | | \$ 85,000 |



QUALIFICATIONS & ASSUMPTIONS

Marshall Classroom Building

Oxnard School District

2900 Thurgood Marshall Dr, Oxnard, CA 93036

GMP

July 20, 2017

| The following items provide additional clarifications regarding the scope of work included in the Proposal: | |
|---|--|
| 1 | All Testing and inspection including shop inspection. All testing and inspection will be performed by the authority having jurisdiction or a third party hired by the owner. |
| 2 | GMP excludes all permanent connection or use fees by outside utility companies. |
| 3 | Settlement surveys of adjacent properties or utilities are excluded. |
| 4 | Owner's FFE items - GMP does not include furnishing, installation, unloading / hoisting or storage of Owner's FF&E. |
| 5 | Metalworks Linear Faceted/Curved Ceiling system 8" panel per Note 9.03/G-006, see detail 4/A-541 (no sheet A-541 provided) at Elevators, is excluded. |
| 6 | Does not include Owner's mobile shelf units, rolling desks, or similar non-fixed furniture. |
| 7 | Natural gas service line to new building not shown on Site Utility Plan C-401,402,403,404 or P-sheets is not included, but is addressed by allowance. |
| 8 | Using Metal Sales Standing Seam roof in lieu of AEP Span Span-Lock per specifications. |
| 9 | Window blinds are not included at the sectional doors, only at the classroom windows even though they are not shown. |
| 10 | Epoxy grout is not included at ceramic tile. |
| 11 | Vapor emission treatment at concrete floors is not included. |
| 12 | TV brackets are OFCI. Televisions or monitors are not included. |
| 13 | Specification Section 23 25 00 - Water Treatment is excluded. |
| 14 | Hazardous or contaminated soils handling or removal, or removal of any existing underground tanks or appurtenances, is excluded. |
| 15 | No standing guard service is included for school site during the Edison rework of the main power. District to provide guard service. |
| 16 | Existing handball walls will be demolished (total of 5). GMP does not include any replacement of these ball walls. |
| 17 | GMP does not include any seal and re-stripe of existing asphalt play courts - not shown on plans. |
| | |
| | |

VALUE ENGINEERING COST TRACKING LOG

Marshall Classroom Building

Oxnard School District

2900 Thurgood Marshall Dr, Oxnard, CA 93036

July 19, 2017

| CCD Required | NO | COST TRACKING DESCRIPTION | NEXT ACTION/STEP/COMMENTS |
|--------------|-------|---|---|
| | | Building | |
| CCD | ARC.1 | Replace 8'6"x13' sectional roll up doors with smaller sized aluminum glazed window frames and plaster walls | <p>JA to prepare elevation replace (10) sectional OH doors with windows in punched openings of a plaster wall and drywall wall</p> <p>Update 06/23/17: Sketched due 06/30/17</p> <p>Update 7/6/17: Sketches received from CSDA and circulated to subs for pricing. Requested responses by no later than 7/10/17.</p> <p>Update 7/18/17: Clarification to aluminum window type and glass type received from CSDA and subs have provided their proposals.</p> |
| CCD | ARC.2 | Eliminate Smoke Containment doors at elevators, possibly not required | <p>JA to call FLS plan checker to determine if these can be eliminated.</p> <p>Update 06/23/17: CCD-A to delete smoke doors shall be prepared by 06/30/17 and submitted when DSA Box is set up.</p> |
| | ARC.3 | Eliminate sliding markerboards, keep recessed wall space for mobile shelf units. | <p>After discussion with the team this part of the programmatic design which cannot be eliminated. TM to work with bidders on how to reduce the cost of the current design</p> <p>Update 06/23/17: TM is working with Nelson Adams to achieve projected savings without impacting this programmatic element</p> <p>Update 7/6/17: Revised pricing received from Nelson Adams for sliding markerboards @ 6' in height, same widths as shown on interior elevations. VE credit combined with ARC.4</p> <p>Additional cost for painting exposed wall surfaces are combined with ARC.3</p> |
| | ARC.4 | Decrease size of floor to ceiling markerboard and tackboard surfaces | <p>JA to prepare revised elevation to reduce the height of the wall mounted markerboards and acoustical tackboard</p> <p>Update 06/23/17: TM is working with Nelson Adams to achieve projected savings without impacted this programmatic element</p> <p>Update 7/6/17: Revised pricing received for wall markerboards @ 6' in height, same widths as shown on interior elevations. VE credit combined with ARC.3</p> <p>Additional cost for painting exposed wall surfaces are combined with ARC.3.</p> <p>Update 7/7/17: Jeremy C. provided clarification that sliding markerboards will not change in size. Carl will follow up with Nelson Adams to revise their VE proposal based on this information.</p> <p>Update 7/18/17: Revised pricing received from Nelson Adams. All sliding markerboards remain full height as shown on the drawings, wall markerboards and tackboards will become 6' in height.</p> |
| | ARC.5 | Eliminate acoustical wall panels in upper clerestory areas | <p>JA to revise RCP to delete acoustical wall panels in upper clerestory. JA to incorporate use of acoustical ceiling panels on vertical surfaces.</p> <p>Update 06/23/17: SB directed JA to delete acoustical wall panels in the clerestory walls. TM to confirm \$30K saving</p> <p>Update 7/6/17: Credit provided for deleting these panels in the clerestory wall areas. Additional cost for painting exposed wall surfaces are also provided.</p> |
| | ARC.6 | Eliminate wall tile behind lockers in Rooms 111 & 114. | <p>After discussion with the team it was determined that all tile will be eliminated from the scope of work in the changing rooms. See ARC.18 below</p> |
| | ARC.7 | Lower height of wainscot tile in restrooms to 4' high | <p>RS to provide pricing for proposed revision</p> <p>Update 06/23/17: Pricing for credit received from Silverado Tile.</p> |
| | ARC.8 | Eliminate floor tile in Toilet and changing rooms. Replace with a sealed concrete finish. | <p>See ARC 18 below</p> |

VALUE ENGINEERING COST TRACKING LOG

Marshall Classroom Building

Oxnard School District

2900 Thurgood Marshall Dr, Oxnard, CA 93036

July 19, 2017

| CCD Required | NO | COST TRACKING DESCRIPTION | NEXT ACTION/STEP/COMMENTS |
|--------------|--------|---|---|
| | ARC.9 | Replace entire roof with hot mop- Roofing VE Items | RS to provide pricing for hot mop roof through out the project. Update 06/23/17: TM working with Best Interior to develop a value engineering package that retains the existing design. Update 7/6/17: CM has discussed potential VE items with Best, including use of a lighter gauge standing seam roofing material. Update 7/18/17: Use of a lighter gauge standing seam roofing material is not acceptable to CSDA. Best Contracting looked again at their number and submitted a credit amount. |
| CCD | ARC.10 | Use standard Hydraulic elevators in lieu of MRL elevator | JA to provide revised design for using a jack less hydraulic elevator Update 06/23/17: SB directed team to pursue the hydraulic elevator. TM to forward shop drawing for hydraulic elevator to JA for coordination with designed structure for the shaft and equipment room Update 7/6/17: Republic Elevator has provided drawings for space requirements of the elevator shaft and machine room. CSDA has reviewed and indicates that required space requirements will work within current designed structure. |
| | ARC.11 | Delete energy management system. | RS to obtain credit to delete EMS in it entirety Update 06/23/17: Sheldon provided credit. |
| | ARC.12 | Delete fire department ladders | JA to call fire marshal to understand requirement of exterior fire ladders Update 06/23/17: JA and TM to visit fire department to delete exterior ladders for building and elevator tower Update 7/6/17: Per Jose/CSDA the exterior ladders as shown on G-003 will not be required based on discussion with the local fire department. |
| CCD | ARC.13 | Delete framing at elevator opening smoke doors. | SB accepted deletion. Finalize credit to GMP. |
| CCD | ARC.14 | Delete hand dryers | SB accepted deletion. Finalize credit to GMP JA to revise specifications to include paper towel dispensers Update 06/23/17: Paper towel dispensers shall OFCI. |
| CCD | ARC.15 | Revise Guardrail Detail | JA to review design of handrail detail and revise to simplify and reduce cost. Also see ARC.19 below Update 06/23/17:CA Buchen provided revised design for guardrails which was accepted by SB and JA. Credit provided by CA Buchen. |
| | ARC.16 | Use thinset in lieu of mortar set tile | After discussion with the team it was determined that the mortar bed would be deleted at 1st and 2nd floor restrooms and that the tile would be thinset. Need to add the sloping of floor to drains. RB to provide pricing Update 06/23/17: Credit provided by Silverado. |
| CCD | ARC.17 | Remove 2nd floor canopy over walkways | JA to review the shading study and determine if a portion of the walkway cover can be reduced Update 06/23/17: Still pending structural engineer response. JA to follow on 06/26/17 Update 7/6/17: Jose/CSDA has been working with the structural engineer for drawings/details in order for Bernards to request subcontractor pricing. Update 7/18/17: The structural engineer provided drawings on 7/18/17 for subs to review and provide pricing. |
| | ARC.18 | Delete all tile from change rooms and provide painted walls and resilient tile with rubber base | RS to provide pricing for proposed revisions. Update 06/23/17:Credit provided by Silverado. |
| | ARC.19 | Delete galvanized finish for stairs, guardrails and handrails and provide zinc primer with paint finish | RS to provide pricing for proposed revisions. Update 06/23/17: Steel contractor stated the is no cost difference with zinc coating and galvanizing. |

VALUE ENGINEERING COST TRACKING LOG

Marshall Classroom Building

Oxnard School District

2900 Thurgood Marshall Dr, Oxnard, CA 93036

July 19, 2017

| CCD Required | NO | COST TRACKING DESCRIPTION | NEXT ACTION/STEP/COMMENTS |
|--------------|--------|--|--|
| | ARC.20 | Delete requirement of waterproof wrap around building | JA to review specification to determine what is required and RS to reach out to plaster subcontractors to determine what is included Update 06/23/17: TM got price to wrap the first 5 feet of the building. |
| | ARC.21 | Delete drywall soffit at high ceiling and provide T-Bar and acoustical tile. | JA to prepare sketch of proposed T-Bar soffit for final pricing Update 7/6/17: Jose/CSDA has rejected this potential VE item. |
| | ARC.22 | Revise operable windows to fixed windows | JA to revise specification for windows. TM to price Update 7/6/17: Jose/CSDA has revised the aluminum window spec and pricing has been requested from subcontractor. Update 7/18/17: CSDA revised the aluminum window spec. again and answered subcontractor questions. Subcontractor has provided credit for fixed windows in place of operable. |
| | ARC.23 | Flush Aluminum Windows with Exterior wall | JA to revise specification for windows. TM to price Update 7/6/17: Jose/CSDA has revised the aluminum window spec and pricing has been requested from subcontractor. Update 7/18/17: CSDA revised the aluminum window spec. again and answered subcontractor questions. Subcontractor has provided credit for fixed windows in place of operable. JA to revise detail for window install. TM to price Update 7/6/17: Jose/CSDA has revised the aluminum spec and pricing has been requested from subcontractor. Update 7/18/17: CSDA revised the aluminum window spec. again. Window width is now 4 1/2" but still held to outside with return on inside of wall. |
| | ARC.24 | HVAC VE Items | Meeting with CFW, Bernards and Sheldon Mechanical to discuss potential VE items. Items include deduct for standalone control system vs. DDC control system, deduct to change side discharge rooftop units to down shot, deduct to change ductwork from rectangular to round and added cost to install copper coils on rooftop units. Update 7/7/17: The copper fin added cost has been rejected. The (3) credit items are still under consideration. Jose A. to follow up with mechanical engineer to question why his response to down shot roof top units will not work. Update 7/18/17: Mechanical engineer has rejected the proposed down shot type units due to space limitations. Credits for standalone control system and use of round ducts will be accepted. |
| | ARC.25 | Electrical VE Items | Taft Electric has been contacted regarding potential VE items and have submitted the following; Deduct for alternate light fixture package using a different manufacturer, deduct for use of MC cables for all branch circuits in lieu of flex conduit, deduct for use of aluminum brass in lieu of copper on all switchgear, deduct for use of native soil in lieu of concrete backfill at ductbanks. The Electrical Engineer has reviewed and provided a response, to be reviewed further with CFW & CSDA. Update 7/7/17: After reviewing the electrical VE items it was determined to still pursue the potential cost savings of an alternate lighting package and also request a cost savings number for use of slurry backfill in ductbank trenches. Update 7/18/17: Potential cost savings for the alternate lighting package is acceptable. Taft Electric confirmed no savings for use of slurry backfill in ductbank trenches. |

VALUE ENGINEERING COST TRACKING LOG

Marshall Classroom Building

Oxnard School District

2900 Thurgood Marshall Dr, Oxnard, CA 93036

July 19, 2017

| CCD Required | NO | COST TRACKING DESCRIPTION | NEXT ACTION/STEP/COMMENTS |
|--------------|--------|---|---|
| | ARC.26 | Door Hardware Savings (hinges, etc.) | Scott B. requested a door hardware cost savings for use of butt hinges instead of the specified continuous hinges. Scott will forward a copy of District hardware standards to Carl for discussion with the subcontractor for any potential savings. |
| | ARC.27 | Plumbing VE Savings | Carl M. will contact the low bid plumbing subcontractor to discuss any potential cost saving items. |
| | SIT.1 | Eliminate construction of (5) CIP concrete seat benches, District to provide benches | SB accepted deletion. Finalize credit to GMP Update 7/6/17: Credit for deleted concrete benches requested from subcontractor. Update 7/18/17: Credit proposal received from subcontractor. |
| | SIT.2 | Remove PCC Pavers and concrete sub-slab for pavers, leave existing AC paving. | SB accepted deletion. Finalize credit to GMP Update 7/6/17: Credit for deleted concrete pavers and sub slab requested from subcontractor. Update 7/18/17: Credit proposal received from subcontractor. |
| CCD | SIT.3 | Remove raised planter walls - concrete, rebar, waterproofing and landscaping & irrigation | After discussion it was determined to eliminate all raised planters but retain all landscaping at grade. RS to finalize credit for deletion of raised planters JA to provide revised design for landscaping at grade for pricing Update 7/18/17: Credit proposal received from subcontractors for deleted raised planters. Revised landscape drawings not provided, no change in cost proposed for landscaping at planters. |
| CCD | SIT.4 | Remove concrete mow strip, replace with natural grass | JA to review with DSA the need to 6' mow strip with plan checker Update 06/23/17: JA to submit CCD to delete 6' mow strip Update 7/6/17: Pricing has been requested from subcontractor for revising mow strip from 60" to 12" wide. Update 7/18/17: Credit proposal received from subcontractor. |
| | SIT.5 | Delete gravity wall, use curb | JA to review with Civil if gravity wall can be deleted. This would me budget funds to delete the demolition of the ball walls could be removed. Update 06/23/17: JA to confirm with civil engineer that gravity wall can be deleted. Update 7/7/17: This potential VE item has now been rejected. |
| | SIT.6 | Delete perimeter curb & 4" CAB w/ geo fabric at rubber play surface, install rubber surfacing | Rejected |
| | SIT.7 | Delete site concrete mock-up | SB accepted deletion. Finalize credit to GMP |
| | SIT.8 | Reduce cost reconstruction at new electrical service | JA to have civil engineer provide demo and construction for new electrical service. Update 7/6/17: Site photos of the area for SCE work and approximate electrical underground pathway back to the electrical room have been provided to CSDA for use by Civil Engineer. Update 7/7/17: Carl M. will go back into the GMP and verify if there are still potential costs available. Update 7/18/17: After reviewing costs again with estimators, a cost savings was determined. |



VALUE ENGINEERING COST TRACKING LOG

Marshall Classroom Building

Oxnard School District

2900 Thurgood Marshall Dr, Oxnard, CA 93036

July 19, 2017

| CCD Required | NO | COST TRACKING DESCRIPTION | NEXT ACTION/STEP/COMMENTS |
|-----------------|-------|---------------------------|--|
| | SIT.9 | Gas Line Revisions | <p>Meeting with Gas Company and Engineer to resolve missing gas design took place on 6/26/17 with the So Cal Gas representative. The rep is currently investigating in house on pipe capacity and meter and will report back to Team. There is the possibility that the meter will need to be upsized, which will be a cost to the School District.</p> <p>Update 7/7/17: Jose A. will request that plumbing engineer contact the Gas Co. rep to receive information in order to make final decision.</p> <p>Update 7/18/17: The Gas Company representative has been contacted by Bernards on numerous occasions for an update with no response. CSDA's plumbing engineer is also awaiting a return call. With no clear response to date from Gas Co. this potential VE credit will be rejected. The 50K allowance will continue to be carried in the GMP.</p> |

Bid Evaluation Report



Erosion Control

Marshall Classroom Building

Subcontractors

| | |
|---------------------|------------------|
| Job Number | 1641 |
| Bid Date | 6/7/2017 |
| Date Printed | 7/27/2017 |

| Description | Whitson CM / Bernards | Social Stormwater Runoff Solution | | | |
|---|-----------------------|-----------------------------------|--|--|--|
| Base Bid | See below | See below | | | |
| Spec #: 312500 | Included | Included | | | |
| Bond Rate (if required) | | | | | |
| Furnished, Installed, FOB Jobsite, Tax Included | Included | Included | | | |
| Plans and Specs Dated: 1/28/2016 & 10/4/2016 | Included | Included | | | |
| Acknowledgment of RFIs 1-75 dated 6.5.17 | Included | Included | | | |
| Bid Good for 60 Days | | | | | |
| Prevailing Wage | Included | Included | | | |
| Prequalified per Oxnard School District Standards | N/A | N/A | | | |
| Attachment C Acknowledgement | N/A | N/A | | | |
| Storm Water Compliance | 1,200 | 520 | | | |
| "Due to the project being under 1 acre this project is not subject to the State CGP" | Included | Included | | | |
| Provide project related Water Pollution Control Program (WPCP) by Qualified developer | Included | Included | | | |
| Development of project specific Best Management Practices (BMP's) | Included | Included | | | |
| Development of erosion control plan for inclusion in WPCP | Included | Included | | | |
| SWPPP (QSP/QSD) Services | | | | | |
| Qualified SWPPP Practitioner QSP conduct weekly site inspections, photos, document, etc | 18,720 | 10,400 | | | |
| Rate per week for monitoring | \$360/wk | \$200/visit | | | |
| Keep records & documents updated | Included | Included | | | |
| Provide recommendations for reqs of BMP upkeep & maintenance (but won't do the work) | Included | Included | | | |
| Electronically file all data for Permit documents as required | Included | Included | | | |
| Pre/During/Post Rain-Event Visual Inspections | 4,320 | 2,640 | | | |
| Rate per week/visit for monitoring the rain monitoring | \$360/wk | \$220/visit | | | |
| Erosion Control - No Plans Provided | 21,402 | 21,402 | | | |
| Silt Fencing at perimeter of sites | Included | Included | | | |
| Fiber Rolls at perimeter of existing parking lot rework - A-102 | Included | Included | | | |
| Fiber Rolls at new school addition perimeter - G-003 | Included | Included | | | |
| Fiber Rolls at new playground area perimeter - G-003 | Included | Included | | | |
| Construction Entrances | Included | Included | | | |

Bid Evaluation Report

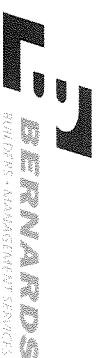

Erosion Control

Marshall Classroom Building

Subcontractors

Job Number **1641**
 Bid Date **6/7/2017**
 Date Printed **7/27/2017**

| Description | Whitson CM / Bernards | Social Stormwater Runoff Solution | Subcontractors | | | |
|--|-----------------------|-----------------------------------|----------------|----------|----------|----------|
| | | | Amount | | | |
| Storm Drain Inlet Protection | Included | Included | | | | |
| SWPPP & BMP Implementation | Included | Included | | | | |
| SWPPP & BMP Implementation - Removal at completion of project | Included | Included | | | | |
| QSP Monitoring | See below | See below | | | | |
| Laydown/Trailer Area Erosion Control: | 20,985 | 20,985 | | | | |
| Fiber Rolls at perimeter of existing grass field for trailer/parking/laydown/storage use during construction | Included | Included | | | | |
| Geofabric over the grass, rock surface | Included | Included | | | | |
| Removal of above at project completion | Included | Included | | | | |
| Temporary Construction Fencing & Gates - Bernards | 22,730 | 22,730 | | | | |
| Temp Fencing at existing parking lot rework, 1-side use existing fencing along the creek - A-102, install, maintain, removal | Included | Included | | | | |
| Temp Fencing at new school addition perimeter - G-003 | Included | Included | | | | |
| Temp Fencing at new playground area perimeter - G-003 | Included | Included | | | | |
| Gates | Included | Included | | | | |
| TOTALS | 89,357 | 78,677 | 0 | 0 | 0 | 0 |
| Recommendation: | Amount | | | | | |
| Social Stormwater Runoff Solution | 78,677 | | | | | |

Bid Evaluation Report

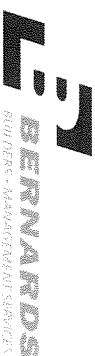

Surveying

Marshall Classroom Building

Subcontractors

| Description | Adkan Engineers | Brenner & Carpenter | Hunsaker & Associates | MNS Engineers | Job Number | 1641 |
|--|-----------------|---------------------|-----------------------|---------------|-----------------------------|---------------|
| | | | | | Date Printed | 7/27/2017 |
| | | | | | Bid Date | 6/7/2017 |
| | | | | | Michael Baker International | Stantec |
| Base Bid | 22,000 | 25,000 | 60,400 | 17,055 | 8,900 | 39,950 |
| Spec #: 00700 - General Conditions | Included | Included | Included | Included | Included | Included |
| Bond Rate (if required) | N/A | N/A | N/A | N/A | N/A | N/A |
| Furnished, Installed, FOB Jobsite, Tax Included | Included | Included | Included | Included | Included | Included |
| Plans and Specs Dated: 1/28/2016 & 10/4/2016 | Included | Included | Included | Included | Included | Included |
| Acknowledgment of RFIs 1-75 dated 6.5.17 | Included | Included | Included | Included | Included | Included |
| Bid Good for 60 Days | Included | Included | Included | Included | Included | Included |
| Prevailing Wage | Included | Included | Included | Included | Included | Included |
| Prequalified per Oxnard School District Standards | N/A | N/A | N/A | N/A | N/A | N/A |
| Attachment C Acknowledgement | N/A | N/A | N/A | N/A | N/A | N/A |
| Set-up | Included | Included | Included | Included | Included | Included |
| Travel Costs | Included | Included | Included | Included | Included | Included |
| Horizontal Control | Included | Included | Included | Included | Included | Included |
| Survey Boundary Map | Included | Included | Included | Included | Included | Included |
| Excavation | Included | Included | Included | Included | Included | Included |
| Rough Grade Staking | Included | Included | Included | Included | Included | Included |
| Blueprint Stakes at Bottom of Excavation for Fine Grading | Included | Included | Included | Included | Included | Included |
| Gridlines at Elevator & Exterior Stairs | Included | Included | Included | Included | Included | Included |
| Buildings | Included | Included | Included | Included | Included | Included |
| Building Corner Stakes (All Bids) | Included | Included | Included | Included | Included | Included |
| Utility Sleeve Layout for Sanitary Sewer, Storm Drain, Domestic and Fire Water, Natural Gas and Permanent Electrical Service | Included | Included | Included | Included | Included | Included |
| Final Verification Upon Project Completion | Included | Included | Included | Included | Included | Included |
| Site | Included | Included | Included | Included | Included | Included |
| Stakes for Sanitary Sewer, Storm Drain, Natural Gas and Domestic Fire & Domestic Water | Included | Included | Included | Included | Included | Included |
| Line and Grade Stakes for Underground Electrical Devices, POCs and Duct Banks | Included | Included | Included | Included | Included | Included |
| Line Stakes for demo/saw cut of asphalt at existing northeast parking lot. Provide markings for new parking stalls. | Included | Included | Included | Included | Included | Included |
| Line and grade stakes for rubberized playground area | Included | Included | Included | Included | Included | Included |
| 1-person survey crew rate per hour | \$185/hr | | \$192/hr | \$180/hr | Included | Included |
| 2-person survey crew rate per hour | \$260/hr | | \$234/hr | \$260/hr | | |
| | 5,000 | 2,000 | | 6,667 | | |
| TOTALS | 27,000 | 27,000 | 60,400 | 23,722 | 20,900 | 39,950 |
| Recommendation: | Amount | | | | | |
| Michael Baker International | 20,900 | | | | | |

Bid Evaluation Report



Reinforcing Steel

Marshall Classroom Building

Subcontractors

Job Number: 1641
 Bid Date: 6/7/2017
 Date Printed: 7/27/2017

| Description | Upland Contracting | | Vista Steel | | Subcontractors | | Job Number | Bid Date | Date Printed |
|---|--------------------|----------|---------------|----------|----------------|----------|------------|----------|--------------|
| | | | | | | | | | |
| Base Bid | | | | | | | | | |
| Spec #: 032000 | 85,814 | Included | 83,445 | Included | | | | | |
| Bond Rate (if required) | | | | | | | | | |
| Furnished, Installed, FOB Jobsite, Tax Included | | | | | | | | | |
| Plans and Specs Dated: 1/28/2016 & 10/4/2016 | | | | | | | | | |
| Acknowledgment of RFIs 1-75 dated 6.5.17 | | | | | | | | | |
| Bid Good for 60 Days | | | | | | | | | |
| Prevailing Wage | | | | | | | | | |
| Pregualified per Oxnard School District Standards | | | | | | | | | |
| Attachment C Acknowledgement | | | | | | | | | |
| | | | | | | | | | |
| Rebar | | | | | | | | | |
| New Classroom Addition Building per Structural, Architectural & Civil sheets | | | | | | | | | |
| Rebar for Footings | | | | | | | | | |
| Rebar for Spread Footings | | | | | | | | | |
| Rebar for Column Footings | | | | | | | | | |
| Rebar for Stair Footings | | | | | | | | | |
| Rebar for Pad Footings | | | | | | | | | |
| Rebar for Elevator Pit | | | | | | | | | |
| Rebar for Slab on Grade | | | | | | | | | |
| Hoisting as Required | | | | | | | | | |
| | | | | | | | | | |
| Note 15 - Planter Wall per Architectural & Structural drawings - 2 shown near stairs are NOT on S sheets, 36'x8', build them sim to right side of det 6/S-401 | 5,000 | | 5,000 | | | | | | |
| Site Concrete Reinforcing | 24,486 | | 12,025 | | | | | | |
| Paving, curbs, seat walls, planter walls | | | | | | | | | |
| Site curbs FOB jobsite | | | | | | | | | |
| SIT.3 | | | | | | | | | |
| | | | | | | | | | |
| | | | | | | | | | |
| TOTALS | 111,800 | | 96,970 | | 0 | 0 | 0 | 0 | |
| Recommendation: | | | | | | | | | |
| Vista Steel | Amount | | 96,970 | | 0 | | 0 | | 0 |

Bid Evaluation Report



Building Concrete

Marshall Classroom Building

Subcontractors

| Description | Barcelo Construction | | Santa Clarita Concrete | | Job Number | Bid Date | Date Printed |
|---|----------------------|----------|------------------------|----------|------------|----------|--------------|
| | 386,879 | Included | 395,600 | Included | | | |
| Base Bid | | | | | 1641 | 6/7/2017 | 7/27/2017 |
| Spec #: 03 1000 - Concrete Forming Accessories | Included | | Included | | | | |
| Spec #: 03 2000 - Concrete Reinforcing | Included | | Included | | | | |
| Spec #: 03 3000 - Cast-In-Place Concrete | Included | | Included | | | | |
| Bond Rate (if required) | | | Bond @ 1% | | | | |
| Furnished, Installed, FOB Jobsite, Tax Included | Included | | Included | | | | |
| Plans and Specs Dated: 1/28/2016 & 10/4/2016 | Included | | Included | | | | |
| Acknowledgment of RFIs 1-75 dated 6.5.17 | Included | | Included | | | | |
| Bid Good for 60 Days | 90 Days | | 30 Days | | | | |
| Prevailing Wage | Included | | Included | | | | |
| Prequalified per Oxnard School District Standards | N/A | | N/A | | | | |
| Attachment C Acknowledgement | N/A | | N/A | | | | |
| Structural Concrete | Included | | Included | | | | |
| Typical SOG Underlayment Detail 14/S-400A: | Included | | Included | | | | |
| 4" layer crushed rocks Subbase over prepared subgrade | Included | | Included | | | | |
| Base - 2" Sand Fill over crushed rock | Included | | Included | | | | |
| 15 mil. Vapor Barrier by Stego Ind. Over sand | Included | | Included | | | | |
| 5" SOG | Included | | Included | | | | |
| Reinforcing steel furnish & install, included w/ CIP concrete bid | Excluded | | Excluded | | | | |
| Reinforcing steel furnish & install, separate Rebar Bid | w/ Rebar | | w/ Rebar | | | | |
| Install Anchor/Sill Bolts for Wood Framing per Wall Framing Details - S-401 | Included | | Included | | | | |
| Spread Footings per Schedule on Foundation Pages S-401,402,403 (WF-1, WF-2 & F3) | Included | | Included | | | | |
| 24" X 18" Conc Footing at Stairs per 1/S-700B | Included | | Included | | | | |
| Tie Rod Brace detail and concrete blockout at Baseplates - 3/S-700B | Included | | Included | | | | |
| 1-6" thk Mat slab at Elevator Pit per 12/S-700A | Included | | Included | | | | |
| Elevator Pit wall 10" thk per 12/S-700B | Included | | Included | | | | |
| Site Control Plan C-201 | | | | | | | |
| Note 15 - Planter Wall per Architectural & Structural drawings - 2 shown on S-211 & 6/S401, are part of the building construction | 30,000 | | Included | | | | |
| Note 15 - Planter Wall per Architectural & Structural drawings - 2 shown near stairs are NOT on S sheets, 36'x8' | 30,000 | | 26,600 | | | | |
| Install Guiderail baseplates per 16/S-700B | Included | | Included | | | | |
| Lt Wt Concrete Fill at Balconies & Classrooms on 2nd Floor per Note 7A & 7B/S212 - 1-1/2" twt concrete topping | Included | | Included | | | | |

Bid Evaluation Report



Building Concrete

Marshall Classroom Building

Subcontractors

| Description | Barcelo Construction | | Santa Clarita Concrete | | Job Number | Bid Date | Date Printed |
|--|----------------------------|----------------------------|------------------------|------------------------|------------|----------|--------------|
| | Barcelo Construction | Santa Clarita Concrete | Barcelo Construction | Santa Clarita Concrete | | | |
| SCC: Deck to be poured prior to construction of walls, otherwise add for another pump system & hoseman to place concrete | Included | 6,500 | | | 1641 | 6/7/2017 | 7/27/2017 |
| Concrete Fill at Pan Filled Metal Stair Treads and Landings w/ W4x4 Reinforcing - 2&6/S-700B | Included | Included | | | | | |
| Balco Stair Strips per keynote 05.03 sheet A-420 & detail 11/A-560 | 2,500 | 2,500 | | | | | |
| 2" contrasting strip, abrasive strip | Included | Included | | | | | |
| 6" Upturned CIP concrete base w/ tooled radius at lockers - 14 & 15/A-530 | Included | Included | | | | | |
| Depressed slabs at restrooms for ceramic tile work, not shown properly | Included | Included | | | | | |
| Trench Drain concrete basin per 4/S-400A | w/ Site Utilities Included | w/ Site Utilities Included | | | | | |
| Other Items: | | | | | | | |
| All Reinforcing Steel for your work | w/ Rebar Included | w/ Rebar Included | | | | | |
| Dewatering as Required | Included | Included | | | | | |
| Setting Anchor Bolt Templates | Included | Included | | | | | |
| Safety walk and progressive cleanup | 4,640 | 4,640 | | | | | |
| Curing and Sealing Compounds per Specs as Required | Included | Included | | | | | |
| Drypacking baseplates | 1,000 | Included | | | | | |
| Base plates for Round HSS and Square HSS per 18/S-401 | Included | Included | | | | | |
| Clean up to debris bins | 5,100 | 5,100 | | | | | |
| Wash Out Bins | 2,500 | 2,500 | | | | | |
| Depressed floors at 1st floor RR's (include, they aren't shown) for ceramic tile install | 5,000 | 5,000 | | | | | |
| Spoils removal | approx 325cy | approx 325cy | | | | | |
| SIT.3 | (8,700) | (8,709) | | | | | |
| SIT.3 | (30,000) | (26,600) | | | | | |
| TOTALS | 428,919 | 413,131 | 0 | 0 | 0 | 0 | 0 |
| Recommendation: | Amount | | | | | | |
| Santa Clarita Concrete | 413,131 | | | | | | |

Bid Evaluation Report



Structural Steel

Marshall Classroom Building

Subcontractors

| Description | C.A. Buchen | Rincon Ironworks | Metal Supply, Inc. | ACSS | Job Number | 1641 |
|---|-------------|------------------|--------------------|--------|--------------|-----------|
| | | | | | Bid Date | 6/7/2017 |
| | | | | | Date Printed | 7/27/2017 |
| Base Bid | See below | See below | See below | No Bid | | |
| Spec #: 05 1200 - Structural Steel Framing | Included | Included | Included | | | |
| Spec #: 05 5000 - Metal Fabrications | Included | Included | Included | | | |
| Bond Rate (if required) | | | | | | |
| Furnished, Installed, FOB Jobsite, Tax Included | Included | Included | Included | | | |
| Plans and Specs Dated: 1/28/2016 & 10/4/2016 | Included | Included | Included | | | |
| Acknowledgment of RFIs 1-75 dated 6.5.17 | Included | Included | Included | | | |
| Bid Good for 60 Days | 14 Days | Included | Included | | | |
| Prevailing Wage | Included | Included | Included | | | |
| Prequalified per Oxnard School District Standards | N/A | N/A | N/A | | | |
| Attachment C Acknowledgement | N/A | N/A | N/A | | | |
| Structural Steel | | | | | | |
| New Classroom Building | 165,450 | 234,955 | 304,688 | | | |
| HSS Steel Columns, C1, C2, C3, C4 & C5 on First & Second Levels -5" round, 5x5 7x5, 10x8, & 7x7 | Included | Included | Included | | | |
| HSS Beams at 1st & 2nd floors per floor plans | Included | Included | Included | | | |
| HSS Beams at Elevator - 3 each HSS 12x4 tubes per sketch in RFI #3 | Included | Included | Included | | | |
| Include added 3rd steel column | 7,500 | 7,500 | 7,500 | | | |
| HSS Columns & beams at wall elevation S-600E & 19&20/S-600F | Included | Included | Included | | | |
| HSS columns in stud walls to have welded studs - 13/S-700 | Included | Included | Included | | | |
| Base plates for Round HSS and Square HSS per 18/S-401 | Included | Included | Included | | | |
| "C" Channel Framing at Elevator - S111 | Included | Included | Included | | | |
| "W" Steel Beams at Elevator - 1/S-700A & 17/S-700A | Included | Included | Included | | | |
| Beam to Beam Connection Schedule & details 1/S-700A | Included | Included | Included | | | |
| Double angle braces & gusset plate at HSS column at roof transitions 17/S-600D | Included | Included | Included | | | |
| 1/2" thk x 5" w plate at roof transitions 17/S-600D & 20/S-600E | Included | Included | Included | | | |
| Safety Cable Railing as Required - Install, maintain, removal & return to steel sub | 3,250 | 3,250 | 3,250 | | | |
| FOB Anchor Bolts/ Templates for Own Work | Included | Included | Included | | | |
| FOB Embeds, Weld Plates, etc. for Own Work | Included | Included | Included | | | |
| Safety walk and progressive cleanup | 3,093 | 3,093 | 3,093 | | | |
| Hoisting for All Work | Included | Included | Included | | | |
| Steel Stairs | | | | | | |
| Galvanized | 122,090 | Included | Included | | | |

Bid Evaluation Report

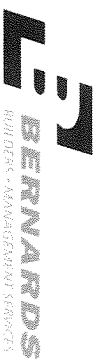

Structural Steel

Marshall Classroom Building

Subcontractors

| Description | C.A. Buchen | Rincon Ironworks | Metal Supply, Inc. | ACSS | Job Number | 1641 |
|---|-------------|------------------|--------------------|---------|--------------|-----------|
| | | | | | Bid Date | 6/7/2017 |
| | | | | | Date Printed | 7/27/2017 |
| Stairs 1 & 2 at New Classroom Bldg - S-211,212 & S-700B | Included | Included | Included | | | |
| Steel Stairs (Pan Filled Concrete) - A-420 | Included | Included | Included | | | |
| HSS, MC, C Stringers, L Brackets and Metal Pan Landings | Included | Included | Included | | | |
| Conc Nosing at Stairs - included w/ the stairs? | 1,250 | Included | Included | | | |
| Stair Railings and Stair Guardrails | Included | Included | Included | | | |
| 1-1/2" Handrail Both Sides | Included | Included | Included | | | |
| Guardrail at Midlandings | Included | Included | Included | | | |
| Guardrail at Top of Stairs | Included | Included | Included | | | |
| Stair 1 - 12/S700B | Included | Included | Included | | | |
| Stair 2 - 11/S700B | Included | Included | Included | | | |
| Railings & Guardrails | Included | 132,560 | Included | 100,000 | | |
| 2nd Floor New Classroom Bldg - S-212 & 8/S-6001/S-600D | Included | Included | Included | | | |
| Deck guardrail detail - HSS2-1/2x2-1/2x3/16 at 4'oc | Included | Included | Included | | | |
| Arch drawing sheet A-112, note 5.33, see 15/A-560 | Included | Included | Included | | | |
| Steel posts & plate top rails, w/ baseplates 8/S-600 | Included | Included | Included | | | |
| Railing to have a Prefab panel per 10/A-560 | Orsogril | Included | Included | | | |
| Prefab Panel Elevation detail - 7/A-560 | Included | Included | Included | | | |
| Railing Inserts per detail 2.3/A-560 - shows 2x1 rect mesh 11 ga galv panel | Included | Included | Included | | | |
| Railing Inserts per Spec is diamond mesh | Excluded | Excluded | Excluded | | | |
| Misc. Metal | Included | Included | Included | | | |
| Steel plate continuous across hoistway ground fl - 5/A-561 | 2,500 | Included | 2,500 | | | |
| Steel plate continuous across hoistway 2nd fl- 7/A-561 | 2,500 | Included | 2,500 | | | |
| Pit ladder 13/A-561, notes states by Elev Mfr, but needs to be w Steel | Included | 3,000 | Included | | | |
| HSS at Canopy connections - 19,20/S-600F | Included | Included | Included | | | |
| Elevator Sill Angle & Threshold | Included | Included | Included | | | |
| Roof Access Ladders in Electrical rm 206 - A-112, 10/A-500 | Included | Included | Included | | | |
| Steel ladder mounted to wall mtg all OSHA requirements | Included | Included | Included | | | |
| Site | Included | Included | Included | | | |
| Steel Bollards at New Electrical Transformer, FOB jobsite, 1/E-102 | 500 | 4,000 | 4,000 | | | |
| Steel Bollards at New DDCV Assembly, FOB jobsite, C-401 (not shown, include 8 each) | 500 | 4,000 | 4,000 | | | |

Bid Evaluation Report

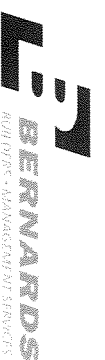

Structural Steel

Marshall Classroom Building

Subcontractors

| Description | C.A. Buchen | Rincon Ironworks | Metal Supply, Inc. | ACSS | Job Number | 1641 |
|--|----------------|------------------|--------------------|----------|--------------|-----------|
| | | | | | Bid Date | 6/7/2017 |
| | | | | | Date Printed | 7/27/2017 |
| Fire Department Access Ladder, shown on FLS/Site Plan near grid D&2 SW side - G-003, galvanized | 7,500 | 6,500 | 7,500 | | | |
| Fire Department Access Ladder, shown on FLS/Site Plan near grid K&11 near elevator - G-003, galvanized | 7,500 | 6,500 | 7,500 | | | |
| ARC.12 | (15,000) | (13,000) | (15,000) | | | |
| ARC.15 | (14,500) | (14,000) | (14,000) | | | |
| TOTALS | 294,133 | 378,358 | 417,531 | 0 | 0 | 0 |
| Recommendation: | Amount | | | | | |
| C.A. Buchen | 294,133 | | | | | |



Bid Evaluation Report

Rough Carpentry

Marshall Classroom Building

Subcontractors

| | |
|--------------|-----------|
| Job Number | 1641 |
| Bid Date | 6/7/2017 |
| Date Printed | 7/27/2017 |

| Description | Subcontractors | | | |
|--|------------------------|------------------|-----------------|------------|
| | Abdellatif Enterprises | Core Contracting | JF Construction | WS Klem |
| Base Bid | 1,244,000 | 997,037 | 922,861 | 1,156,000 |
| Spec #: 06 1000 - Rough Carpentry | Included | Included | Included | Included |
| Spec #: 06 1733 - Wood I-Joists | Included | Included | Included | Included |
| Spec #: 06 1813 - Glue Laminated Beams | Included | Included | Included | Included |
| Bond Rate (if required) | Bond at 2% | Bond at 2% | Bond at 2% | Bond at 2% |
| Furnished, Installed, FOB Jobsite, Tax Included | Included | Included | Included | Included |
| Plans and Specs Dated: 1/28/2016 & 10/4/2016 | Included | Included | Included | Included |
| Acknowledgment of RFIs 1-75 dated 6.5.17 | Included | Included | Included | 30 days |
| Bid Good for 60 Days | Included | Included | Included | Included |
| Prevailing Wage | N/A | N/A | N/A | N/A |
| Prequalified per Oxnard School District Standards | N/A | N/A | N/A | N/A |
| Attachment C Acknowledgement | N/A | N/A | N/A | N/A |
| Rough Framing | | | | |
| Wall Types Sheet - A-620 | Included | Included | Included | Included |
| Plywood Shear Wall Schedule - S-600 | Included | Included | Included | Included |
| Plywood Sheathing as Shown on Wall Types | Included | Included | Included | Included |
| Prefabricated plywood web joists "I" Joists per spec section | Included | Included | Included | Included |
| Open Web Trusses, I-Joists, LVL per Schedule 4/S-600F | Included | Included | Included | Included |
| MFR - TrusJoist, Red Built or equal | Included | Included | Included | Included |
| Glue-Laminated Beams & Struc Eng. Beams per spec section | Included | Included | Included | Included |
| Simpson HDW as Scheduled | Included | Included | Included | Included |
| Supply Anchor/Sill Bolts for Wood Framing per Wall Framing Details | 7,551 | 7,551 | 7,551 | 7,551 |
| Hold Down Schedule 20/S-600 | Included | Included | Included | Included |
| Anchor Rod Schedule - 17/S-401 | Included | Included | Included | Included |
| Mechanical Platforms at Roof 3&5B/S-700B | Included | Included | Included | Included |
| Wall Framing - 2x4, 2x6, 2x8 | Included | Included | Included | Included |
| Wood Backing for All Wall Items - Millwork, TV's, Marker/Tackboards, Handrails, M.E.P. | Included | Included | Included | Included |
| Plywood Backboards - Electrical / Low Voltage | 3,200 | 3,200 | 3,200 | 3,200 |
| Wood Nailers at Roof Parapet Coping - 2/A-500 | Included | Included | Included | Included |
| Safety Railing as Required at 2nd Floor | 5,000 | 5,000 | 5,000 | 5,000 |
| Plywood Floor Sheathing - 19/S-600C | Included | Included | Included | Included |
| Plywood Roof Sheathing - 19/S600C | Included | Included | Included | Included |
| 1/2" Plywood at Exterior Walls per Struc Walls and Ext. Walls as shown on S-600 | Included | Included | Included | Included |
| Flooring & Roof Joists per Schedule on Framing Plans | Included | Included | Included | Included |
| 1/2" Plywood at Plaster Pilasters | Included | Included | Included | Included |

Bid Evaluation Report



Rough Carpentry

Marshall Classroom Building

Subcontractors

| Description | Subcontractors | | | | Job Number | Bid Date | Date Printed |
|--|------------------------|------------------|------------------|------------------|------------|----------|--------------|
| | Abdellatif Enterprises | Core Contracting | JF Construction | WS Klem | | | |
| Exterior Plywood at Underside of Roof Overhang per 9/A-501 | Included | Included | Included | Included | 1641 | 6/7/2017 | 7/27/2017 |
| Install Pipe Columns per details 2,5,6/5-600D - coordinate w/ Steel sub | Included | Included | Included | Included | | | |
| Roof Joists per Schedule on Framing Plans | Included | Included | Included | Included | | | |
| Roof Crickets per A-131 - should be w/ roofing, use tapered Insul | Excluded | Excluded | Excluded | Excluded | | | |
| Safety walk and progressive cleanup | 9,280 | 9,280 | 9,280 | 9,280 | | | |
| Framing for all recessed items FEC's, etc. | Included | Included | Included | Included | | | |
| Blocking & backing for ceilings & duct supports, unknown locations | 6,400 | 6,400 | 6,400 | 6,400 | | | |
| Blocking & backing for roof ladders | 600 | 600 | 600 | 600 | | | |
| Depressed floors at 2nd floor RR's (include, they aren't shown) for ceramic tile install | 5,000 | 5,000 | 5,000 | 5,000 | | | |
| Framing for doors heads & jambs at elevator smoke containment door assembly | 4,000 | 4,000 | 4,000 | 4,000 | | | |
| Fire Treated Lumber | Included | Included | Included | Included | | | |
| Storage of Lumber and Delivery to Site | Included | Included | Included | Included | | | |
| Hoisting for your work | Included | Included | Included | Included | | | |
| All Required Caulking and Sealants for your work | Included | Included | Included | Included | | | |
| Scaffolding for Own Work | Included | Included | Included | Included | | | |
| Clean-up into your dumpsters | 17,000 | 17,000 | 17,000 | 17,000 | | | |
| Temporary Stairs & ramps | 3,000 | 3,000 | 3,000 | 3,000 | | | |
| Small tools & equipment | 3,500 | 3,500 | 3,500 | 3,500 | | | |
| Security guard | 40,200 | 40,200 | 40,200 | 40,200 | | | |
| Site Security/Alarm/Camera systems | 15,477 | 15,477 | 15,477 | 15,477 | | | |
| ARC.1 | 9,500 | 9,500 | 9,417 | 9,500 | | | |
| ARC.13 | (4,000) | (4,000) | (4,000) | (4,000) | | | |
| ARC.17 | (30,000) | (30,000) | (30,521) | (30,000) | | | |
| Budget for Lumber Cost Increase | 65,000 | 50,000 | 50,000 | 50,000 | | | |
| TOTALS | 1,404,708 | 1,142,745 | 1,067,965 | 1,301,708 | 0 | 0 | |
| Recommendation: | Amount | | | | | | |
| JF Construction | 1,067,965 | | | | | | |



Bid Evaluation Report

Cabinets / Millwork

Marshall Classroom Building

Subcontractors

| Description | Subcontractors | | | | Job Number | Bid Date | Date Printed |
|---|----------------|---------------|---------------|--------------------|------------|----------|---------------|
| | Bristol Omega | ICI Millwork | K & Z Cabinet | Dennis Reeves Inc. | | | |
| Base Bid | 47,900 | 36,107 | 42,290 | 34,161 | 1641 | 6/7/2017 | |
| Spec # : 06 4000 - Architectural Woodwork | Included | Included | Included | Included | | | |
| Spec # : 12 3553 - Manufactured Plastic-Laminate-Faced Casework | Included | Included | Included | Included | | | |
| Bond Rate (if required) | | | | Bond at 2.5% | | | |
| Furnished, Installed, FOB Jobsite, Tax Included | Included | Included | Included | Included | | | |
| Plans and Specs Dated: 1/28/2016 & 10/4/2016 | Included | Included | Included | Included | | | |
| Acknowledgment of RFIs 1-75 dated 6.5.17 | Included | Included | Included | Included | | | |
| Bid Good for 60 Days | 90 days | 90 days | 60 days | 60 days | | | 45 days |
| Prevailing Wage | Included | Included | Included | Included | | | Included |
| Prequalified per Oxnard School District Standards | N/A | N/A | N/A | N/A | | | N/A |
| Attachment C Acknowledgement | N/A | N/A | N/A | N/A | | | N/A |
| Millwork | | | | | | | |
| Lower Cabinets with Hardware | Included | Included | Included | Included | | | Included |
| Upper Cabinets with Hardware & Locks on all doors per RFI # | Included | Included | Included | Included | | | Included |
| Plastic Laminate Finish | Included | Included | Included | Included | | | Included |
| Plastic Laminate Countertops | Included | Included | Included | Included | | | Included |
| Plastic Laminate Backsplash | Included | Included | Included | Included | | | Included |
| Enlarged Floor Plans - A-410 | Included | Included | Included | Included | | | Included |
| Casework details per A-570 | Included | Included | Included | Included | | | Included |
| Include the back panel fastening per 2/A-570 | Included | Included | Included | Included | | | Included |
| Include the Cont 2-1/2"x2-1/2" x 16 ga bent sheet metal angle anchorage - 6/A-570 | Included | Included | Included | Included | | | Included |
| Typical Classroom per 1/A-410 | Included | Included | Included | Included | | | Included |
| Casework & Counters | Included | Included | Included | Included | | | Included |
| Rms - 101, 102, 103, 104 | Included | Included | Included | Included | | | Included |
| Rms - 201, 202, 203, 204, 207 | Included | Included | Included | Included | | | Included |
| Typical Science Classroom per 2/A-410 | Included | Included | Included | Included | | | Included |
| Casework & Counters | Included | Included | Included | Included | | | Included |
| Rms - 107, 109 | Included | Included | Included | Included | | | Included |
| Performing Arts Lab per 3/A-410 | Included | Included | Included | Included | | | Included |
| Casework & Counters | Included | Included | Included | Included | | | Included |
| Rms - 208 | Included | Included | Included | Included | | | Included |
| Locker Room Benches | Included | w/ Lockers | w/ Lockers | w/ Lockers | | | w/ Lockers |
| FRP Panels | | | | | | | |
| | Excluded | Excluded | Excluded | Excluded | | | Excluded |
| TOTALS | 47,900 | 36,107 | 42,290 | 34,161 | | | 35,270 |
| Recommendation: | Amount | | | | | | |
| Dennis Reeves Inc. | 34,161 | | | | | | |

Bid Evaluation Report



Waterproofing

Marshall Classroom Building

Subcontractors

| Description | Systems WP | Proulx | Santa Barbara Surfacing | Letner | Job Number | 1641 |
|---|---------------|-------------------|-------------------------|-----------------|---------------------|---------------|
| | | | | | Patriot Contracting | Paul Wolff |
| | | | | | Bid Date | 6/7/2017 |
| | | | | | Date Printed | 7/27/2017 |
| Base Bid | See below | See below | See below | See below | 83,560 | Incomplete |
| Spec #: 07 1326 - Self Adhering Sheet Waterproofing | Included | Included | Included | Included | Included | Included |
| Spec #: 07 8400 - Fire Stop and Smoke Seals | w/ Insulation | w/ Insulation | w/ Insulation | w/ Insulation | w/ Insulation | w/ Insulation |
| Spec #: 07 9200 - Joint Sealants | Included | Included | Included | Included | Included | Included |
| Bond Rate (if required) | Included | Included | Bond @ 1.8% | Bond @ 1.5% | Bond @ 1% | Included |
| Furnished, Installed, FOB Jobsite, Tax Included | Included | Included | Included | Included | Included | Included |
| Plans and Specs Dated: 1/28/2016 & 10/4/2016 | Included | Included | Included | Included | Included | Included |
| Acknowledgment of RFI's 1-75 dated 6.5.17 | Included | Included | Included | Included | Included | Included |
| Bid Good for 60 Days | Included | 90 days | 90 days | 60 days | 60 days | Included |
| Prevailing Wage | Included | Included | Included | Included | Included | Included |
| Prequalified per Oxnard School District Standards | N/A | N/A | N/A | N/A | N/A | N/A |
| Attachment C Acknowledgement | N/A | N/A | N/A | N/A | N/A | N/A |
| Waterproofing | | | | | | |
| Waterproofing at elevator pit 12/A-561 | 4,100 | 2,300 | 8,300 | 3,510 | Included | No Bid |
| Sheet Waterproofing behind Pit walls | Included | Included | Included | Bituthene 4000 | Included | ----- |
| 1" drainage board & sheet waterproofing at walls | Included | Included | Included | Included 230 sf | Included | ----- |
| Waterproofing under elev pit SOG (no specs) use bentonite, Grace PrePrufe300R or equal | Included | Included | Included | Included | Included | ----- |
| Elastomeric waterproofing on top of pit slab (no spec) - use crystalline product | 1,500 | 2,500 | 5,400 | 2,500 | Included | ----- |
| Waterproofing at elevator pit penetrations 8/A-561 | Included | Included | Included | Included | Included | ----- |
| Waterproofing of foundation wall at planter areas against the bldg C-300 | 14,030 | 18,240 | Included | 15,000 | Included | ----- |
| Waterproofing inside exterior Planters - total of 4 planters 6/S-401 | Included | Included 1,920 sf | Included | Included | Included | ----- |
| Waterproofing under topping slabs at 2nd floor decks - 6&7/A-510 | 18,000 | 20,000 | 22,600 | 20,000 | Included | ----- |
| Use 07 1326, self adhering waterproofing OR | Included | Included | Included | Included | Included | ----- |
| Use 60-90mil liquid applied waterproofing w/ 1/8" asphaltic board or drainage mat protection course | Included | Included | Included | Included | Included | ----- |
| Safety walk and progressive cleanup | 3,480 | 3,480 | 3,480 | 3,480 | 3,480 | ----- |
| Traffic Coatings | | | | | | |
| Per Pre-Bid RFI#4 | 20,560 | 22,330 | 27,050 | 29,860 | Included | No Bid |
| Installed over 2nd floor exterior deck - 6 & 7/A-510 | Included | Included | Included | Included | Included | ----- |
| Installed over exterior stairs and landings - not shown | Excluded | Excluded | Excluded | Excluded | Excluded | ----- |
| Product to be Poly-I-Gard 246SF by Polycoat Products OR | Included | Included 2,552 sf | Included | Excluded | Included | ----- |

Bid Evaluation Report



Waterproofing

Marshall Classroom Building

Subcontractors

| Description | Systems WP | | | | Proulx | | | | Santa Barbara Surfacing | | | | Lethner | | | | Patriot Contracting | | Paul Wolff | | | |
|--|----------------------|---------------|----------|---------------|----------|---------------|----------|---------------|-------------------------|---------------|----------|----------|----------|----------|----------|----------|---------------------|----------|------------|-------|--|--|
| | Included | Excluded | Included | Excluded | Included | Excluded | Included | Excluded | Included | Excluded | Included | Excluded | Included | Excluded | Included | Excluded | Included | Excluded | | | | |
| Product to be Gaco Western, GW-15-U62 | | 2,680 | | 2,680 | | 2,680 | | 2,680 | | 2,680 | | 2,680 | | 2,680 | | 2,680 | | 2,680 | | 1,750 | | |
| Interior Concrete Sealed Floors | | | | | | | | | | | | | | | | | | | | | | |
| Interior concrete floors shown on Finish Sch A-612 marked F1 | Included | | Included | | Included | | Included | | Included | | Included | | Included | | Included | | Included | | Included | | | |
| No Spec Provided OR see 03300,2.1,G | Included | | Included | | Included | | Included | | Included | | Included | | Included | | Included | | Included | | Included | | | |
| Caulking & Sealants | | | | | | | | | | | | | | | | | | | | | | |
| Per Schedule in Specs | Included | | Included | | Included | | Included | | Included | | Included | | Included | | Included | | Included | | Included | | | |
| Windows, Doors, Walls, As Shown | Included | | Included | | Included | | Included | | Included | | Included | | Included | | Included | | Included | | Included | | | |
| SIT.3 | | (10,530) | | (10,500) | | (10,500) | | (10,500) | | (10,500) | | (10,500) | | (10,500) | | (10,500) | | (10,500) | | | | |
| TOTALS | | 63,636 | | 70,846 | | 69,996 | | 76,346 | | 89,036 | | 0 | | | | | | | | | | |
| Recommendation: | | | | | | | | | | | | | | | | | | | | | | |
| Systems WP | Amount 63,636 | | | | | | | | | | | | | | | | | | | | | |



Bid Evaluation Report

Insulation

Marshall Classroom Building

Subcontractors

| Description | Subcontractors | | | | Roberts Firestop |
|---|----------------|-------------------|-----------|---------------|------------------|
| | DJ Insulation | Viking Insulation | Alcal | TruTeam/Masco | |
| Base Bid | 26,800 | 36,892 | 30,527 | 26,895 | See below |
| Spec #: 07 2100 - Thermal Insulation | Included | Included | Included | Included | N/A |
| Spec #: 07 8400 - Fire Stop and Smoke Seals | No Bid | No Bid | No Bid | No Bid | Included |
| Bond Rate (if required) | | | | | |
| Furnished, Installed, FOB Jobsite, Tax Included | Included | Included | Included | Included | Included |
| Plans and Specs Dated: 1/28/2016 & 10/4/2016 | Included | Included | Included | Included | Included |
| Acknowledgment of RFIs 1-75 dated 6.5.17 | Included | Included | Included | Included | Included |
| Bid Good for 60 Days | 60 Days | Included | 30 days | 60 days | Included |
| Prevailing Wage | Included | Included | Included | Included | Included |
| Prequalified per Oxnard School District Standards | N/A | N/A | N/A | N/A | N/A |
| Attachment C Acknowledgement | N/A | N/A | N/A | N/A | N/A |
| Thermal and Blanket Insulation | | | | | |
| Interior, Exterior Walls, Ceilings, Roof | Included | Included | Included | Included | No Bid |
| R19 & 8" Batts at Int & Ext Walls | Included | Included | Included | Included | ----- |
| R30 at Roof (Not shown) | See below | See below | See below | See below | ----- |
| Walls to Receive Insulation per Wall Types A-620 | Included | Included | Included | Included | ----- |
| Wall type A - min 3" sound insulation | Included | Included | Included | Included | ----- |
| Wall type B - double stud walls min 3" sound insulation | Included | Included | Included | Included | ----- |
| Wall type C - min 3" sound insulation | Included | Included | Included | Included | ----- |
| Wall type D - min 3" sound insulation | Included | Included | Included | Included | ----- |
| Wall type E1 - min 3-1/2" foil-faced glass fiber batts | ???? | Included | Included | Included | ----- |
| Wall type F - Batt insulation | Included | Included | Included | Included | ----- |
| Wall type G - Batt insulation | Included | Included | Included | Included | ----- |
| Wall type H - min 3" sound insulation | Included | Included | Included | Included | ----- |
| Wall type I - min 3" sound insulation | Included | Included | Included | Included | ----- |
| Wall type K - double stud walls Int. Acoustic wall - fiberglass batt insulation | Included | Included | Included | Included | ----- |
| Wall type N - none shown | ----- | ----- | ----- | ----- | ----- |
| Wall type O - batt insulation | Included | Included | Included | Included | ----- |
| Rigid Insulation at PVC roofing | w/ Roofing | Included | Included | Included | ----- |
| Rigid Insulation at Standing Seam roofing | Excluded | Included | Included | Included | ----- |
| R-30 insulation at underside of standing seam roofing | 7,500 | Included | Included | 4,965 | ----- |
| Fire Stops and Smoke Seals | | | | | |
| Mineral fiber insulation fire safing, damming material, clips and closures | 17,324 | 17,324 | 17,324 | 17,324 | 17,324 |
| Seal openings in floors, fire rated walls & penetrations | Included | Included | Included | Included | Included |
| At pipes, ducts, conduits & other items shown | Included | Included | Included | Included | Included |

Bid Evaluation Report

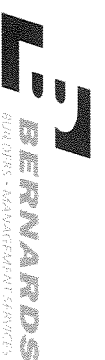

Insulation

Marshall Classroom Building

Subcontractors

| Description | DJ Insulation | Viking Insulation | Alcal | TruTeam/Masco | Roberts Firestop | Job Number | 1641 | |
|--|---------------|-------------------|---------------|---------------|------------------|--------------|-----------|--|
| | | | | | | Bid Date | 6/7/2017 | |
| | | | | | | Date Printed | 7/27/2017 | |
| MFR - Bio Fireshield, 3M, GE or Nelson | Included | Included | Included | Included | Included | | | |
| Sealants, firestop putty, mortar, pillows, mineral fiber saifing | Included | Included | Included | Included | Included | | | |
| TOTALS | 51,624 | 54,216 | 47,851 | 49,184 | 0 | | 0 | |
| Recommendation: | Amount | | | | | | | |
| Alcal | 47,851 | | | | | | | |

Bid Evaluation Report

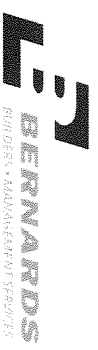

Sheet Metal & Metal Panels

Marshall Classroom Building

Subcontractors

| Description | R&J SM | Letter | Commercial Roofing | Merit Metal Products | Job Number | |
|---|-------------|-------------|--------------------|----------------------|---------------------|----------------------|
| | | | | | Patriot Contracting | Valencia Sheet Metal |
| | | | | | Date Printed | 7/27/2017 |
| | | | | | Bid Date | 6/7/2017 |
| Base Bid | See below | 167,950 | See below | See below | 189,170 | 1641 |
| Spec #: 07 4000 - Metal Roof Panels | Included | Included | Included | Included | Included | Included |
| Spec #: 07 6000 - Flashing Sheet Metal | Included | Included | Included | Included | Included | Included |
| Bond Rate (if required) | Bond @ 2.5% | Bond @ 1.5% | Bond @ 1% | Bond @ 1% | Bond @ 1% | Bond @ 2% |
| Furnished, Installed, FOB Jobsite, Tax Included | Included | Included | Included | Included | Included | Included |
| Plans and Specs Dated: 1/28/2016 & 10/4/2016 | Included | Included | Included | Included | Included | Included |
| Acknowledgment of RFI's 1-75 dated 6.5.17 | Included | Included | Included | Included | Included | Included |
| Bid Good for 60 Days | 30 Days | 90 days | 60 days | 60 days | 60 days | 30 days |
| Prevailing Wage | Included | Included | Included | Included | Included | Included |
| Prequalified per Oxnard School District Standards | N/A | N/A | N/A | N/A | N/A | N/A |
| Attachment C Acknowledgement | N/A | N/A | N/A | N/A | N/A | N/A |
| Sheet Metal | 56,198 | Included | No Bid | 8,600 | Included | Included |
| Exterior Elevations A-210, A-211; Building Sections A-310, 311, 320, 321, 322 | Included | Included | ----- | 40,000 | Included | 40,000 |
| Roof Plan A-131 | Included | Included | ----- | Included | Included | Included |
| Flexible Flashing and Underlayment | Included | Included | ----- | Included | Included | Included |
| Underlayment Single-ply self adhesive Waterproofing membrane per 09 2200.2.02.K | Included | Included | ----- | Included | Included | Included |
| MFR - WR Grace, Jiffy-Seal or equal | Included | Included | ----- | Included | Included | Included |
| Include membrane behind joints & backing at items exposed to weather, under metal copings & flashings & window jambs & sills per spec | Included | Included | ----- | Included | Included | Included |
| Roof Details Sheet A-500: | Included | Included | ----- | Included | Included | Included |
| Parapet Coping w/ cont cleat both sides - 22 Ga - 2/A-500 | Included | Included | ----- | Included | Included | Included |
| Flashing at mechanical unit curbs - 4/A-500 Not clearly shown | Included | Included | ----- | Included | Included | Included |
| Roof penetration at Ducts flashing - 5/A-500 | Included | Included | ----- | Included | Included | Included |
| Flash at Pipes penetrations - 6/A-500 | Included | Included | ----- | Included | Included | Included |
| Flash at Exhaust duct - 9/A-500 | Included | Included | ----- | Included | Included | Included |
| Flash at roof access hatch - 10/A-500 | Included | Included | ----- | Included | Included | Included |
| Flash at fascias - 5/A-501 | Included | Included | ----- | Included | Included | Included |
| Flash at upper roof exterior soffits - 6/A-501 | Included | Excluded | ----- | Included | Included | Included |
| Flash at roof opening details 7/A-501, 20 ga cont cleat | Included | Included | ----- | Included | Included | Included |
| Cap sloped on cement plaster beam 22 ga gsm w/ cont cleats both sides 10/A-510 | Included | Included | ----- | Included | Included | Included |
| Door & Window Sill/Head Flashings - 1.2/A-5120 | Included | Included | ----- | Included | Included | Included |
| Door head flashing - 10-12/A-520 | Included | Included | ----- | Included | Included | Included |
| Metal Corner trims at jambs of Sectional Garage doors - 12/A-521 | Included | Included | ----- | Included | Included | Included |
| Balcony Flashing at 2nd Floor deck guardrail - 15/A-560 | Included | Included | ----- | Included | Included | Included |
| Roof to plaster conditions | Included | Included | ----- | 6,400 | Included | 9,010 |
| Gutters & Downspouts - None Shown | Included | Included | ----- | Included | Included | Included |

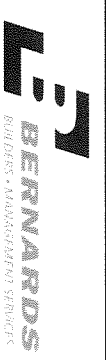

Sheet Metal & Metal Panels

Marshall Classroom Building

| | |
|---------------------|----------------------|
| Job Number | 1641 |
| Bid Date | 6/7/2017 |
| Date Printed | 7/27/2017 |
| Patriot Contracting | Valencia Sheet Metal |

| Description | Subcontractors | | | | Job Number | Date Printed | Patriot Contracting | Valencia Sheet Metal |
|--|-----------------------|-----------------------|-------------------------------|---------------------------|-----------------------|---------------------------|---------------------|-----------------------|
| | R&J SM | Letner | Commercial Roofing | Merit Metal Products | | | | |
| Galvanized, Rectangular Shaped, from flat roofs, not shown | 10,000 | 10,000 | ----- | 10,000 | 10,000 | 10,000 | Included | Included |
| Connects to storm drains systems, not shown | Included | Included | ----- | Included | Included | Included | Included | Included |
| Roof Drains are internal pipes by plumber | Included | Included | ----- | Included | Included | Included | Included | Included |
| Mechanical Equipment pad covers - None Shown | N/A | N/A | ----- | N/A | N/A | N/A | N/A | N/A |
| Work at Outside Storage Unit per 07 6000 1.01B.9 | N/A | N/A | ----- | N/A | N/A | N/A | N/A | N/A |
| Roof Hatch | 7,122 | Included | No Bid | Included | Included | Included | Included | Included |
| Roof Plan A-131, Keynote 07.08 Roof Access Hatch 108.12/A-500, 30"x42" min size | Included | Included | ----- | Included | Included | Included | Included | Included |
| MFR - Acudor, Bilco, Dur-Red, Milcor - Not Listed | Included | Included | ----- | Included | Included | Included | Included | Included |
| Prefab Curb by MFR | Included | Included | ----- | Included | Included | Included | Included | Included |
| Installed in Electrical Room 206 | Included | Included | ----- | Included | Included | Included | Included | Included |
| Metal Roofing | 159,537 | Included | 202,181 | 84,000 | Included | Included | Included | Included |
| Roof Plan A-131, Keynote 07.25 Standing Seam Metal Roof 10/A-501 | Included | Included | Included | Included | Included | Included | Included | Included |
| Typical Standing Mtl roof detail 10/A-5010 | Included | Included | Included | Included | Included | Included | Included | Included |
| MFR AEP Span, SpanLok | Included | Included | Included | Alt Prod: Metal Sales | Included | Included | Included | Alt Prod: Metal Sales |
| Per Specs call for 20 ga. / All bids are calling for 22 ga., so 22ga is basis of bid | Included | Incl 24ga | Included | Included | Included | Included | Included | Included |
| 30#lb felt underlayment over roof plywood(by others) | Included | Included | Included | Included | Included | Included | Included | Included |
| Standing seam roof panels fastened w/ 1-1/2" pancake head screws | Included | Included | Included | Included | Included | Included | Included | Included |
| Flash standing seam at Fascia - 5/A-501 | Included | Included | Included | Included | Included | Included | Included | Included |
| Flash Fascia 2 at standing seam 9/A-501 | Included | Included | Included | Included | Included | Included | Included | Included |
| Gutters & Downspouts - None Shown - at low side of standing seam roofs | Included | Not shown | Included | Not shown | Not shown | Not shown | Not shown | Not shown |
| Downspouts to be sch40 pipe & galv downspouts to flat roofs | Included | Included | Included | Included | Included | Included | Included | Included |
| Waste Disposal | 3,400 | 3,400 | 3,400 | 3,400 | 3,400 | 3,400 | 3,400 | 3,400 |
| Provide Alternate Add if not in base bid | ----- | 14,000 | Included | 8,500 | 15,000 | 9,000 | | |
| Wall Louvers | | | | | | | | |
| As listed /shown on Mechanical | w/ HVAC Metal Roof SM | w/ HVAC Metal Roof SM | w/ HVAC Metal Roof Only No SM | w/ HVAC Alt Metal Roof SM | w/ HVAC Metal Roof SM | w/ HVAC Alt Metal Roof SM | | |
| TOTALS | 236,257 | 195,350 | 205,581 | 160,900 | 217,570 | 175,290 | | |
| Recommendation: | Amount | | | | | | | |
| Merit Metal Products | 160,900 | | | | | | | |

Bid Evaluation Report

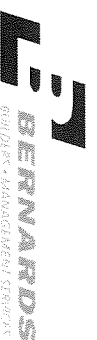

Sheet Metal & Metal Panels

Marshall Classroom Building

Subcontractors

Job Number 1641
 Bid Date 6/7/2017
 Date Printed 7/27/2017

| Description | Craig Roofing | Chapman Coast | | | |
|---|---------------|---------------|--|--|--|
| Base Bid | See below | 0 | | | |
| Spec #: 07 4000 - Metal Roof Panels | Included | SM only | | | |
| Bond Rate (if required) | Included | w/roofing bid | | | |
| | Bond @ 2.5% | | | | |
| Furnished, Installed, FOB jobsite, Tax Included | Included | | | | |
| Plans and Specs Dated: 1/28/2016 & 10/4/2016 | Included | | | | |
| Acknowledgment of RFI's 1-75 dated 6.5.17 | Included | | | | |
| Bid Good for 60 Days | 30 Days | | | | |
| Prevailing Wage | Included | | | | |
| Prequalified per Oxnard School District Standards | N/A | | | | |
| Attachment C Acknowledgement | N/A | | | | |
| Sheet Metal | | | | | |
| Exterior Elevations A-210, A-211; Building Sections A-310, 311, 320, 321, 322 | Included | 9,550 | | | |
| Roof Plan A-131 | Included | | | | |
| Flexible Flashing and Underlayment | Included | | | | |
| Underlayment Single-ply self adhesive Waterproofing membrane per 09 2200.2.02.K | Included | | | | |
| MFR - WR Grace, Jiffy-Seal or equal | Included | | | | |
| Include membrane behind joints & backing at items exposed to weather, under metal copings & flashings & window jambs & sills per spec | Included | | | | |
| Roof Details Sheet A-500: | Included | | | | |
| Parapet Coping w/ cont cleat both sides - 22 Ga - 2/A-500 | Included | | | | |
| Flashing at mechanical unit curbs - 4/A-500 Not clearly shown | Included | | | | |
| Roof penetration at Ducts Flashing - 5/A-500 | Included | | | | |
| Flash at Pipes penetrations - 6/A-500 | Included | | | | |
| Flash at Exhaust duct - 9/A-500 | Included | | | | |
| Flash at roof access hatch - 10/A-500 | Included | | | | |
| Flash at fascias - 5/A-501 | Included | | | | |
| Flash at upper roof exterior soffits - 6/A-501 | Included | | | | |
| Flash at roof opening details 7/A-501, 20 ga cont cleat | Included | | | | |
| Cap sloped on cement plaster beam 22 ga gsm w/ cont cleats both sides 10/A-510 | Included | | | | |
| Door & Window Sill/Head Flashings - 1.2/A-5120 | Included | | | | |
| Door head flashing - 10-12/A-520 | Included | | | | |
| Metal Corner trims at jambs of Sectional Garage doors - 12/A-521 | Included | | | | |
| Balcony Flashing at 2nd Floor deck guardrail - 15/A-560 | Included | | | | |
| Roof to plaster conditions | 9,000 | | | | |
| Gutters & Downspouts - None Shown | Included | | | | |

Bid Evaluation Report



Sheet Metal & Metal Panels

Marshall Classroom Building

Subcontractors

Job Number 1641
 Bid Date 6/7/2017
 Date Printed 7/27/2017

| Description | Craig Roofing | Chapman Coast | | | | | |
|--|-----------------------|-----------------------|----------|----------|----------|----------|----------|
| Galvanized, Rectangular Shaped, from flat roofs, not shown | 10,000 | | | | | | |
| Connects to storm drains systems, not shown | Included | | | | | | |
| Roof Drains are internal pipes by plumber | Included | | | | | | |
| Mechanical Equipment pad covers - None Shown | N/A | | | | | | |
| Work at Outside Storage Unit per 07 6000 I.01B.9 | N/A | | | | | | |
| Roof Hatch | Included | | | | | | |
| Roof Plan A-131, Keynote 07.08 Roof Access Hatch | Included | | | | | | |
| 10&12/A-500, 30"x42" min size | Included | | | | | | |
| MFR - Acudor, Blico, Dur-Red, Millicor - Not Listed | Included | | | | | | |
| Prefab Curb by MFR | Included | | | | | | |
| Installed in Electrical Room 206 | Included | | | | | | |
| Metal Roofing | 218,820 | | | | | | |
| Roof Plan A-131, Keynote 07.25 Standing Seam Metal Roof 10/A-501 | Included | | | | | | |
| Typical Standing Mt roof detail 10/A-5010 | Included | | | | | | |
| MFR AEP Span, SpanLok | Included | | | | | | |
| Per Specs call for 20 ga. / All bids are calling for 22 ga., so 22ga is basis of bid | Included | | | | | | |
| 30#lb felt underlayment over roof plywood(by others) | Included | | | | | | |
| Standing seam roof panels fastened w/ 1-1/2" pancake head screws | Included | | | | | | |
| Flash standing seam at Fascia - 5/A-501 | Included | | | | | | |
| Flash Fascia 2 at standing seam 9/A-501 | Included | | | | | | |
| Gutters & Downspouts - None Shown - at low side of standing seam roofs | Included | | | | | | |
| Downspouts to be sch40 pipe & galv downspouts to flat roofs | Included | | | | | | |
| Waste Disposal | ----- | | | | | | |
| Provide Alternate Add if not in base bid | | | | | | | |
| Wall Louvers | 0 | | | | | | |
| As listed /shown on Mechanical | w/ HVAC Metal Roof SM | No Metal Roof SM Only | | | | | |
| TOTALS | 275,928 | 0 | 0 | 0 | 0 | 0 | 0 |
| Recommendation: | Amount | | | | | | |
| Merit Metal Products | 160,900 | | | | | | |

Bid Evaluation Report



Roofing

Marshall Classroom Building

Subcontractors

| Description | Best Contracting | Chapman Coast | Commercial Roofing | Craig Roofing | Letner Roofing | WSP Roofing | Job Number | 1641 |
|--|-------------------|------------------|--------------------|----------------|----------------|------------------|--------------|-----------|
| | | | | | | | Bid Date | 6/7/2017 |
| | | | | | | | Date Printed | 7/27/2017 |
| Base Bid | 124,725 | 153,939 | 145,717 | 199,708 | 211,750 | 129,179 | | |
| Spec #: 07 5416 - Polyvinyl Chloride (PVC) Roofing (Mechanically Attached) | Included | Included | Included | Included | Included | Included | | |
| Bond Rate (if required) | | | | | | | | |
| Furnished, Installed, FOB Jobsite, Tax Included | Included | Included | Included | Included | Included | Included | | |
| Plans and Specs Dated: 1/28/2016 & 10/4/2016 | Bond @ 1% | Bond @ 1.5% | Bond @ 1.5% | Bond @ 1.5% | Bond @ 1.5% | Bond @ 1.5% | | |
| Acknowledgment of RFI's 1-75 dated 6.5.17 | Included | Included | Included | Included | Included | Included | | |
| Bid Good for 60 Days | 30 days | 60 Days | 60 Days | 45 days | 60 Days | Included | | |
| Prevailing Wage | Included | Included | Included | Included | Included | Included | | |
| Prequalified per Oxnard School District Standards | N/A | N/A | N/A | N/A | N/A | N/A | | |
| Polyvinyl-Chloride (PVC) Roofing | Included | Included | Included | Included | Included | Included | | |
| Roof Plan A-131, Keynote 07.01 Single-Ply Roof Assembly see 1/A-500 | Included | Included | Included | Included | Included | Included | | |
| MFR - Sika Sarnafil, Johns Manville, Carlisle or Equal | Sarnafil | Carlisle | Sarnafil | Included | Included | Included | | |
| BOD Sarnafil S327 FB, thermoplastic membrane w/ poly reinforcement & feltback membrane | Included | Included | Included | Included | Included | Included | | |
| Single Ply Roofing System 60 mill without fleece backing, color to be White | Included 7,000 sf | Included 6,600sf | Included | Included | Included | Included 7,000sf | | |
| Fully Adhered | Included | Included | Included | Included | Included | Included | | |
| Mechanically Fastened | Included | Included | Included | Included | Included | Included | | |
| R-30 Rigid Isoocyanurate foam Insulation w/ black mat facers | Included | Included | Included | Included | Included | Included | | |
| Tapered crickets w/ Insulation | Included | Included | Included | Included | Included | Included | | |
| 1/2" DensDeck Coverboard at Roof | Included | Included | Included | Included | Included | Included | | |
| Include all attachment components & flashing materials | Included | Included | Included | Included | Included | Included | | |
| Include misc flashing at pipes, corners coverstrips, termination bars | Included | Included | Included | Included | Included | Included | | |
| Include all sealants | Included | Included | Included | Included | Included | Included | | |
| Safety walk and progressive cleanup | 4,640 | 4,640 | 4,640 | 4,640 | 4,640 | 4,640 | | |
| Walk Pads - Per Roofing Plans | Included | Included | Included | Included | Included | Included | | |
| Polyester reinforced, 0.096 inch weldable membrane w/ surface embossment per spec 2.07.A | Included | Included | Included | Included | Included | Included | | |
| Parapet walls to be plaster | Included | Included | Included | Included | Included | Included | | |
| Waste disposal | 4,250 | 4,250 | 4,250 | 4,250 | 4,250 | 4,250 | | |
| Warranty to be 10-yr NDL Material & Labor warranty | Included | Included | Included | Included | Included | Included | | |
| ARC.9 | (4,800) | (4,500) | (4,500) | (4,500) | (4,500) | (4,500) | | |
| ARC.17 | (10,280) | (10,000) | (10,000) | (10,000) | (10,000) | (10,000) | | |
| TOTALS | 118,535 | 148,329 | 140,107 | 194,098 | 206,140 | 123,569 | | |
| Recommendation: | Amount | | | | | | | |

Bid Evaluation Report



| | | | | | | |
|-------------------------|-------------------------|------------------------------------|---------------------------|----------------------|-----------------------|--------------------|
| Roofing | | Marshall Classroom Building | | | Job Number | 1641 |
| | | Subcontractors | | | Bid Date | 6/7/2017 |
| | | | | | Date Printed | 7/27/2017 |
| Description | Best Contracting | Chapman Coast | Commercial Roofing | Craig Roofing | Letner Roofing | WSP Roofing |
| Best Contracting | 118,535 | | | | | |



Bid Evaluation Report

Doors, Frames & Hardware

Marshall Classroom Building

Subcontractors

| Description | Construction Hardware | Design Hardware | RK&G Construction | Star Hardware | Job Number | |
|---|-----------------------|-----------------|-------------------|---------------|------------|--------------|
| | | | | | Bid Date | 1641 |
| | | | | | | Date Printed |
| | | | | | | 7/27/2017 |
| Base Bid | 99,420 | 113,689 | 132,696 | 102,265 | | 115,060 |
| Spec #: 08 1113 - Hollow Metal Doors and Frames | Included | Included | Included | Included | | Included |
| Spec #: 08 1416 - Flush Wood Doors | Included | Included | Included | Included | | Included |
| Spec #: 08 3116 - Access Panels & Frames | Included | Included | Included | Included | | Included |
| Spec #: 08 3613 - Sectional Doors | Included | Included | Included | Included | | Included |
| Spec #: 08 7100 - Door Hardware | Included | Included | Included | Included | | Included |
| Bond Rate (if required) | Bond @1.5% | Bond @1.5% | Bond @2.5% | | | |
| Furnished, Installed, FOB Jobsite, Tax Included | Included | Included | Included | Included | | Included |
| Plans and Specs Dated: 1/28/2016 & 10/4/2016 | Included | Included | Included | Included | | Included |
| Acknowledgment of RFI's 1-75 dated 6.5.17 | Included | Included | Included | Included | | Included |
| Bid Good for 60 Days | 60 Days | 60 Days | 30 days | Included | | Included |
| Prevailing Wage | Included | Included | Included | Included | | Included |
| Prequalified per Oxnard School District Standards | N/A | N/A | N/A | N/A | | N/A |
| Attachment C Acknowledgement | N/A | N/A | N/A | N/A | | N/A |
| Hollow Metal Doors and Frames | | | | | | |
| MFR per Specs | Included | Included | Included | Included | | Included |
| Frame Details - A-520 | Included | Included | Included | Included | | Included |
| New Classroom Building - 1st & 2nd fl | Included | Included | Included | Included | | Included |
| HM Frames () | Included | Included | Included | Included | | Included |
| Type A | Included | Included | Included | Included | | Included |
| Type B | Included | Included | Included | Included | | Included |
| Type C | w/ Spec Drs | w/ Spec Drs | w/ Spec Drs | w/ Spec Drs | | w/ Spec Drs |
| Type D, Marker Board Sliding Door Schedule | Included | Included | Included | Included | | Included |
| Type E - w/ Louver | Included | Included | Included | Included | | Included |
| HM Doors (30) | Included | Included | Included | Included | | Included |
| Wood Doors (3) | Included | Included | Included | Included | | Included |
| Install HM Doors | Included | Included | Included | Included | | Included |
| Install HM Frames | Included | 8,500 | 8,500 | 8,500 | | 6,350 |
| Install Wood Doors | Included | Included | Included | Included | | Included |
| Glass for Vision Lites & Windows | 3,375 | 3,750 | 3,750 | 3,750 | | 3,375 |
| Door Hardware | | | | | | |
| Hardware per Schedule in Specs | Included | Included | Included | Included | | Included |
| Safety walk and progressive cleanup | 2,320 | 2,320 | 2,320 | 2,320 | | 2,320 |
| Door Thresholds | Included | Included | Included | Included | | Included |
| Misc. Door Hardware - Site Gates | | | | | | |
| Storefront Doors - None Shown | Included | Included | Included | Included | | Included |
| Panic Hardware at Gates - per Accessibility Site Plan - G-004 | Included | Included | Included | Included | | Included |
| Hardware at existing Gates per Gate Schedule, G-004 | Included | Included | Included | Included | | Included |

Bid Evaluation Report



Doors, Frames & Hardware

Marshall Classroom Building

Subcontractors

| Description | Construction Hardware | Design Hardware | RK&G Construction | Star Hardware | Job Number | |
|--|-----------------------|-----------------|-------------------|----------------|------------------|----------|
| | | | | | Estrada Hardware | 1641 |
| | | | | | Date Printed | 6/7/2017 |
| Door G, 520A & 520B - Exit only panic hdwr on push side, key lock on pull side | 3,475 | 5,250 | 5,250 | 5,250 | | |
| Doors 5-1, 5-2, 5-6, 514A: Exit only panic hdwr on push side, key lock side | 4,690 | 4,690 | 4,690 | 4,690 | 4,690 | |
| ARC:26 | (3,170) | (3,000) | (3,000) | (3,000) | (3,000) | |
| TOTALS | 110,110 | 135,199 | 154,206 | 123,775 | 132,270 | 0 |
| Recommendation: | Amount | | | | | |
| Construction Hardware | 110,110 | | | | | |

Bid Evaluation Report



Glass & Glazing

Marshall Classroom Building

Subcontractors

| Description | Santa Barbara Glass | | | Center Glass | | | Coast to Coast | | |
|---|---------------------|----------|----------------|--------------|----------|----------------|----------------|----------|----------|
| | Job Number | Bid Date | 1641 | Job Number | Bid Date | 1641 | Job Number | Bid Date | 1641 |
| Base Bid | | | 79,908 | | | 86,300 | | | |
| Spec #: 08 5113 - Aluminum Windows | | | Included | | | Included | | | |
| Spec #: 08 7100 - Door Hardware | | | N/A | | | N/A | | | |
| Spec #: 08 8000 - Glazing | | | Included | | | Included | | | |
| Bond Rate (if required) | | | Included | | | Included | | | |
| Furnished, Installed, FOB Jobsite, Tax Included | | | Included | | | Included | | | |
| Plans and Specs Dated: 1/28/2016 & 10/4/2016 | | | Included | | | Included | | | |
| Acknowledgment of RFIs 1-75 dated 6.5.17 | | | Included | | | Included | | | |
| Bid Good for 60 Days | | | Included | | | 30 days | | | |
| Prevailing Wage | | | Included | | | Included | | | |
| Prequalified per Oxnard School District Standards | | | N/A | | | N/A | | | |
| Aluminum Windows | | | Included | | | Included | | | |
| Double and Single Hung Windows | | | Included | | | Included | | | |
| Acceptable Manufacturers for Aluminum Windows | | | Included | | | Included | | | |
| Efco Series 684 & 694 | | | Included | | | Series 2700 | | | |
| Traco TR-9000 | | | Included | | | Excluded | | | |
| Graham Series 3000/3100 | | | Included | | | Excluded | | | |
| Peerless Model 4340 & 4140 | | | Included | | | Included | | | |
| New Classroom Bldg - A-111, A-112 | | | Included | | | Included | | | |
| Type A - 5' x 2'-1" | | | Included | | | Included | | | |
| Type B - 3' x 6' | | | Included | | | Included | | | |
| Type C - 5' x 6' | | | Included | | | Included | | | |
| Type D - 5' x 6' | | | Included | | | Included | | | |
| Type E - 3' x 8' | | | Included | | | Included | | | |
| Type F - 5' x 8' | | | Included | | | Included | | | |
| Type G - 5' x 6' | | | Included | | | Included | | | |
| Type H - 5' x 6' | | | Included | | | Included | | | |
| Type I - 3' x 6' | | | Included | | | Included | | | |
| Sealing and Caulking for All Window/Door Systems per Arch Details | | | 3,775 | | | 3,775 | | | |
| Glazing | | | Included | | | Included | | | |
| Glass for Vision Lites & Windows | | | 3,750 | | | Included | | | |
| Include SG - Safety Glazing as Indicated on Window Schedule A-610, per spec 08800 | | | Included | | | Included | | | |
| Include OB - Obscured Glazing as Indicated on Window Schedule A-610, per spec 08800 | | | Included | | | Included | | | |
| Other | | | | | | | | | |
| Field Testing for Water Penetration AAMA E1105, assume 6 ea | | | 4,500 | | | 4,500 | | | |
| Mock-Up | | | 1,250 | | | 1,250 | | | |
| ARC.1 | | | 24,998 | | | 25,000 | | | |
| ARC.22 | | | (4,094) | | | (4,000) | | | |
| TOTALS | | | 114,087 | | | 116,825 | | | 0 |

Bid Evaluation Report



| | | | | | |
|----------------------------|------------------------------------|--------------|----------------|------------------------|------------------|
| Glass & Glazing | Marshall Classroom Building | | | Job Number Bid Date | 1641 6/7/2017 |
| Description | Subcontractors | | | Date Printed | 7/27/2017 |
| Recommendation: | Santa Barbara Glass | Center Glass | Coast to Coast | Amount | 114,087 |
| Santa Barbara Glass | | | | | |

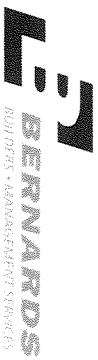

Bid Evaluation Report

Plaster & Drywall

Marshall Classroom Building

| Description | Subcontractors | | | | Perlite Plastering | Pacific Interiors |
|---|----------------|------------------|-------------------|-----------------|--------------------|-------------------|
| | Best Interiors | Standard Drywall | Church and Larsen | Premier Drywall | | |
| Base Bid | See Below | See Below | See Below | Drywall Only | Plaster Only | Dywall Only |
| Spec #: 07 8400 - Fire Stop and Smoke Seals | Included | Included | Included | N/A | N/A | N/A |
| Spec #: 07 9200 - Joint Sealants | Included | Included | Included | N/A | N/A | N/A |
| Spec #: 09 2200 - Cement Plastering | Included | Included | Included | N/A | Included | N/A |
| Spec #: 09 2900 - Gypsum Board | Included | Included | Included | Included | N/A | Included |
| Spec #: 078400, 083100, 072500 | Included | Included | Included | N/A | N/A | N/A |
| Bond Rate (if required) | | | | | | |
| Furnished, Installed, FOB Jobsite, Tax Included | Included | Included | Included | Included | Included | Included |
| Plans and Specs Dated: 1/28/2016 & 10/4/2016 | Included | Included | Included | Included | Included | Included |
| Acknowledgment of RFIs 1-75 dated 6.5.17 | Included | Included | Included | Included | Included | Included |
| Bid Good for 60 Days | 30 Days | 30 Dyas | 30 Dyas | 90 Dyas | 30 Dyas | Included |
| Prevailing Wage | Included | Included | Included | Included | Included | Included |
| Prequalified per Oxnard School District Standards | N/A | N/A | N/A | N/A | N/A | N/A |
| Attachment C Acknowledgement | N/A | N/A | N/A | N/A | N/A | N/A |
| Plaster | 436,210 | 428,681 | 289,224 | 334,700 | 334,700 | 334,700 |
| Exterior Elevations A-210, A-211; Building Sections A-310, 311, 320, 321, 322 | Included | Included | Included | | Included | |
| Keystone 09.11-Portland Cement Plaster and Metal Lath, per wall types | Included | Included | Included | | Included | |
| Texture - Dash Bond Coat 09 2200,3.06,G | Included | Included | Included | | Included | |
| Exterior Plaster Ceilings and Soffits per typ det 11/A-501 | Included | Included | Included | | Included | |
| Exterior Plaster at parapets 2/A-500 | Included | Included | Included | | Included | |
| Interior Plaster per specs, Include if any shown on drawings | Included | Included | Included | | Included | |
| Foam Trim Pieces at Windows if shown to be foam | Included | Included | Included | | Included | |
| Water resistant backing behind metal lath - 09 2200,2.01,E | Included | Included | Included | | Included | |
| Paper Grade D, 60--min rating on wood studs without sheathing, and on plywood sheathing | Included | Included | Included | | Included | |
| Paper Grade B, 16--hour rating on gypsum sheathing | Included | Included | Included | | Included | |
| MFR - Fortifiber, Super Jumbo Tex,USG, Inryco or Western Metal Lath | Included | Included | Included | | Included | |
| 2-Layers Grade D Kraft Paper | Included | Included | Included | | Included | |
| 3-Coat System | Included | Included | Included | | Included | |
| Glass Fiber Reinforcement | Included | Included | Included | | Included | |
| Lath & Paper | Included | Included | Included | | Included | |
| Ribbed Lath at Plaster Ceilings & Soffits | Included | Included | Included | | Included | |
| Stronghold earthquake staples for metal lath at plaster ceilings & soffits 11/A-501, 16/A-502 | Included | Included | Included | | Included | |
| Expansion/Control Joints 9/A-510 | Included | Included | Included | | Included | |
| Plaster Trim | Included | Included | Included | | Included | |

Bid Evaluation Report



Plaster & Drywall

Marshall Classroom Building

Subcontractors

| Description | Best Interiors | Standard Drywall | Church and Larsen | Premier Drywall | Job Number | 1641 |
|---|----------------|------------------|-------------------|-----------------|--------------|----------|
| | | | | | Date Printed | 6/7/2017 |
| Vent & Weep Screeds - 15/A-560 | Included | Included | Included | | Included | |
| Corner Bead - 13/A-510 | Included | Included | Included | | Included | |
| Ceiling expansion joints - 15/A-510 | Included | Included | Included | | Included | |
| Plaster Stops - 5/A-501 | Included | Included | Included | | Included | |
| Underlayment Single-ply self adhesive Waterproofing membrane per 09 2200.2.02.K | 70,000 | 62,686 | 70,000 | 70,000 | 70,000 | 70,000 |
| MFR - WR Grace, Jiffy-Seal or equal | Included | Included | Included | | Included | |
| Include membrane behind joints & backing at items exposed to weather, under metal copings & flashings & window jambs & sills per spec | Included | Included | Included | | Included | |
| Provide vertical Control Joint at each side of the double windows, full ht. south, west and east elevation. Provide horizontal CJ at the bottom of the upper window (aff. +17'-6") to line-up with window sill. Reference details 5 & 9/A-510 (RFI #14) | Included | Included | Included | | Included | |
| All roof parapet walls (interior) and mechanical wall walls to have plaster finish, typical. Ref. detail 2/A-500. (RFI #15) | Included | Included | Included | | Included | |
| Safety walk and progressive cleanup | 11,600 | 11,600 | 11,600 | | 11,600 | |
| Patching, Taping, Floating as Required | Included | Included | Included | | Included | |
| All Required Caulking and Sealants at Penetrations | Included | Included | Included | | Included | |
| Scaffolding for Own Work | 90 Days | 107,323 | Included | | Included | |
| Trade Damage - Plaster (40 Hours) | 5,400 | 5,400 | 5,400 | 5,400 | 5,400 | 5,400 |
| Drywall | | | | | | |
| Drywall per Wall Types Sheet - A-620 | 203,565 | 233,312 | 196,876 | 278,790 | 233,555 | 233,555 |
| This wall job is drywall over wood, no metal studs | Included | Included | Included | Included | Included | Included |
| Wall type A - 1 layer ea side | Included | Included | Included | Included | Included | Included |
| Wall type B - double stud walls 1 layer ea side | Included | Included | Included | Included | Included | Included |
| Wall type C - shear wall 1 layer ea side | Included | Included | Included | Included | Included | Included |
| Wall type D - 1-hr wall 1 layer ea side | Included | Included | Included | Included | Included | Included |
| Wall type E1 - 1-hr wall 1 layer ea side | Included | Included | Included | Included | Included | Included |
| Wall type F - 1 layer ea side | Included | Included | Included | Included | Included | Included |
| Wall type G - ext wall (plywood ea side by others) 1 layer on int, plaster over plywood ext | Included | Included | Included | Included | Included | Included |
| Wall type H - 2 layers ea side | Included | Included | Included | Included | Included | Included |
| Wall type I - 2 layers ea side (over plywood ea side by others) | Included | Included | Included | Included | Included | Included |
| Wall type K - acoustic wall double wood wall, 1 layer ea side, not on int side of double wall | Included | Included | Included | Included | Included | Included |
| Wall type N - int furred wall, 1 layer on one side | Included | Included | Included | Included | Included | Included |

Bid Evaluation Report

Plaster & Drywall

Marshall Classroom Building

| Description | Subcontractors | | | | Perlite Plastering | Pacific Interiors |
|--|------------------------|------------------|-------------------|-----------------|--------------------|-------------------|
| | Best Interiors | Standard Drywall | Church and Larsen | Premier Drywall | | |
| | Job Number Bid Date | Date Printed | 1641 6/7/2017 | 7/27/2017 | | |
| Wall type O - ext wall (plywood ea side by others) 1 layer on int, plaster over plywood ext | Included | Included | Included | Included | | Included |
| Drywall Ceilings per Reflected Ceiling Plans A-121 to A-122 | Included | Included | Included | Included | | Included |
| See sections on sheets A-321-322 for ceiling info | Included | Included | Included | Included | | Included |
| This ceiling job is drywall over wood, there a few areas there is metal framed ceilings? | Included | Included | Included | Included | | Included |
| Finish Schedule A-612, ACT-1 in Classrooms as listed | Included | Included | Included | Included | | Included |
| Impact resistant gypsum board below 10'-0" per Note 2 on Finish Legend A-612 | 5,000 | 5,000 | Included | 5,000 | | 5,000 |
| 5/8" Drywall Horizontal & Vertical surfaces | Included | Included | Included | Included | | Included |
| Cement Backerboard at Restroom Walls | Included | Included | Included | Included | | Included |
| Level 1-5 Finish at Locations per Specifications Based on Paint or Wall Finish spec 09 2900.3.04.A | Level 4&2 | Level 4 | Level 4 | Included | | Included |
| Metal trims, joint treatments & finishing of walls ready for paint | Included | Included | Included | Included | | Included |
| Texture & skim coats where indicated | Included | Included | Included | Included | | Included |
| Clean-up | Included | Included | Included | Included | | Included |
| Fire Resistant Sealants at Head and Base of Walls | Included | Included | Included | Included | | Included |
| Acoustic Sealants as Shown and Spec'd | Included | Included | Included | Included | | Included |
| Installation of HM Door Frames Supplied by Others | w/ DFH | w/ DFH | w/ DFH | w/ DFH | | w/ DFH |
| Supply and Install of Access Panels 12x12 | 3,000 | 3,000 | 3,000 | 3,000 | | 3,000 |
| Installation of FEC Supplied by Others | 1,350 | 1,350 | 1,350 | 1,350 | | 1,350 |
| Install drywall at elevator door frames after they are installed (by others) | 1,500 | 1,500 | 1,500 | 1,500 | | 1,500 |
| Install ceiling at elevator room, not shown | 1,000 | 1,000 | 1,000 | 1,000 | | 1,000 |
| Drywall Pickup | Included | Included | Included | Included | | Included |
| Hoisting for Own Work | Included | Included | Included | Included | | Included |
| Scraping and Disposal | 6,375 | 6,375 | 6,375 | 6,375 | | 6,375 |
| Trade Damage - Drywall (80 Hours) | 10,800 | 10,800 | 10,800 | 10,800 | | 10,800 |
| Fire Stops and Smoke Seals | | | | | | |
| Mineral fiber insulation fire safing, damming material, clips and closures | 7,551 | 7,551 | 7,551 | 7,551 | | 7,551 |
| Seal openings in floors, fire rated walls & penetrations | Included | Included | Included | Included | | Included |
| At pipes, ducts, conduits & other items shown | Included | Included | Included | Included | | Included |
| MFR - Bio Fireshield, 3M, GE or Nelson | Included | Included | Included | Included | | Included |
| Sealants, firestop putty, mortar, pillows, mineral fiber safing | Included | Included | Included | Included | | Included |
| ARC.1 | 9,250 | 9,250 | 9,025 | 9,250 | | 9,250 |
| ARC.17 | (10,000) | (10,000) | (10,300) | (10,000) | | (10,000) |

Bid Evaluation Report

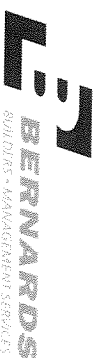

Plaster & Drywall

Marshall Classroom Building

| Description | Subcontractors | | | | Job Number | 1641 |
|--------------------------|----------------|------------------|-------------------|-----------------|--------------------|-------------------|
| | Best Interiors | Standard Drywall | Church and Larsen | Premier Drywall | Bid Date | 6/7/2017 |
| ARC:20 | (70,000) | (62,682) | (70,000) | (70,000) | Date Printed | 7/27/2017 |
| ARC:20 | 5,000 | 5,000 | 4,945 | 5,000 | Perlite Plastering | Pacific Interiors |
| | | | | | (70,000) | (70,000) |
| | | | | | 5,000 | 5,000 |
| TOTALS | 697,601 | 827,146 | 538,346 | 659,716 | 621,081 | 653,005 |
| Recommendation: | Amount | | | | | |
| Church and Larsen | 538,346 | | | | | |

Bid Evaluation Report



Title

Marshall Classroom Building

Job Number 1641

Bid Date 6/7/2017

Date Printed 7/27/2017

Description

Subcontractors

Stonerock Tile

J. Colavin & Son

Silverado Tile

| | | | | | | |
|---|--------------|--------------|--------------|---|--|--|
| Base Bid | 99,325 | 110,210 | 91,500 | 0 | | |
| Spec #: 09 3013 - Ceramic Tiling | Included | Included | Included | | | |
| Furnished, Installed, FOB Jobsite, Tax Included | Included | Included | Included | | | |
| Plans and Specs Dated: 1/28/2016 & 10/4/2016 | Included | Included | Included | | | |
| Acknowledgment of RFIs 1-75 dated 6.5.17 | Included | Included | Included | | | |
| Bid Good for 60 Days | 30 Days | 90 Days | 90 Days | | | |
| Prevailing Wage | Included | Included | Included | | | |
| Prequalified per Oxnard School District Standards | N/A | N/A | N/A | | | |
| Attachment C Acknowledgement | N/A | N/A | N/A | | | |
| Title | Included | Included | Included | | | |
| Finish Schedule A-612: | Included | Included | Included | | | |
| F3-Non-slip Ceramic Tile | Included | Included | Included | | | |
| B2-Coved Ceramic Tile Base | Included | Included | Included | | | |
| W1-Ceramic Tile Walls | Included | Included | Included | | | |
| MFR - Dal-Tile | Included | Included | Included | | | |
| DalTile Keystone 1"x1" Mosaic - Floors | Included | Included | Included | | | |
| DalTile Semi Gloss 6"x6" - Walls | Included | Included | Included | | | |
| Marble Thresholds | 1,500 | 1,500 | 1,500 | | | |
| Setting beds - Mortar and thinset | Included | Included | Included | | | |
| GROUT - Standard, Polymer modified, or Epoxy GROUT - not spelled out in spec | Std grout | Std grout | Std grout | | | |
| Add for epoxy grout | Not provided | Not provided | Add: \$7,650 | | | |
| GROUT Sealer | 4,085 | Included | Included | | | |
| Waterproofing Membrane at depression - 283/A-510 | Included | Included | Included | | | |
| Waterproofing type, 6 are listed in specs, 093013.9.2.1 2.6, which one do you have in your bid? | RedGuard | Included | RedGuard | | | |
| Wall Tile on 5/8" Cementitious Backer Board (by others) - 283/A-510 | By Others | By Others | By Others | | | |
| Install per CTI Method W244, thinset method | Included | Included | Included | | | |
| Floor Tile on depressed concrete slab (by others) - 283/A-510 | By Others | By Others | By Others | | | |
| Install per CTI Method F114, mudset/mortaset method | Included | Included | Included | | | |
| Locations: | Included | Included | Included | | | |
| Boys Toilet rm 110, 210 | Included | Included | Included | | | |
| Boys Changing rm 111 | Included | Included | Included | | | |
| Girls Toilet rms 113, 212 | Included | Included | Included | | | |
| Girls Changing rm 114 | Included | Included | Included | | | |
| Staff Toilet rms 112, 211 | Included | Included | Included | | | |

Bid Evaluation Report

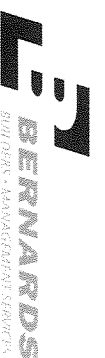

Title

Marshall Classroom Building

Job Number

1641

Bid Date

6/7/2017

Date Printed

7/27/2017

| Description | Subcontractors | | | Amount |
|---|----------------|------------------|----------------|----------|
| | Stonerock Tile | J. Colavin & Son | Silverado Tile | |
| Interior Elevations A-224 | Included | Included | Included | |
| 8' Ht Tile Mainscot (RFI # 24) | Included | Included | Included | |
| Safety walk and progressive cleanup | 2,320 | 2,320 | 2,320 | |
| Include Tile Behind Lockers, Provide Alternate Deduct to Remove | Included | Included | Included | |
| ARC:7 | (21,500) | (21,500) | (21,670) | |
| ARC:16 | (6,000) | (6,000) | (6,240) | |
| ARC:18 | (16,000) | (16,000) | (16,290) | |
| TOTALS | 63,730 | 70,530 | 51,120 | 0 |
| Recommendation: | Amount | | | |
| Silverado Tile | 51,120 | | | |

Bid Evaluation Report

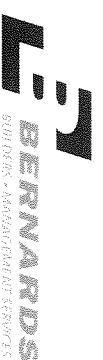

Acoustical Ceilings

Marshall Classroom Building

| Description | Subcontractors | | | | Job Number | 1641 |
|---|------------------|------------------|----------------------|-----------|-----------------|--------------------------|
| | Alert Insulation | Standard Drywall | Commercial Interiors | CG Chaney | Bid Date | 6/7/2017 |
| | | | | | Date Printed | 7/27/2017 |
| | | | | | Prime Acoustics | Hamilton Ceiling Systems |
| Base Bid | 41,500 | 53,030 | 42,490 | 35,775 | 36,000 | 43,700 |
| Spec #: 09 5123 - Acoustical Tile Ceilings | Included | Included | Included | Included | Included | Included |
| Spec #: 09 8434 - Acoustical Wall Panels (from RFI #7) | | | | | Included | |
| Furnished, Installed, FOB Jobsite, Tax Included | Included | Included | Included | Included | Included | Included |
| Plans and Specs Dated: 1/28/2016 & 10/4/2016 | Included | Included | Included | Included | Included | Included |
| Acknowledgment of RFI's 1-75 dated 6.5.17 | Included | Included | Included | Included | Included | Included |
| Bid Good for 60 Days | 30 Days | 30 Days | 30 Days | Included | Included | Included |
| Prevailing Wage | Included | Included | Included | Included | Included | Included |
| Prequalified per Oxnard School District Standards | N/A | N/A | N/A | N/A | N/A | N/A |
| Attachment C Acknowledgement | N/A | N/A | N/A | N/A | N/A | N/A |
| Acoustical Panel Ceilings | | | | | | |
| Reflected Ceiling Plans A-121 to A-122 | Included | Included | Included | Included | Included | Included |
| Finish Schedule A-612, ACT-1 in Classrooms as listed | Included | Included | Included | Included | Included | Included |
| MFR - Armstrong, CertainTeed or USG | USG | Included | Included | USG | CertainTeed | CertainTeed |
| Armstrong Fine Fissured, White, No Pattern, 3/4" Thick 24"x48" | Included | Included | Included | Included | Included | Included |
| Grid - Prelude XL 15/16" Exposed Tee by Armstrong | DXL 26 | Included | Included | Included | Included | Included |
| ACT Details per A-540 | Included | Included | Included | Included | Included | Included |
| Include vertical struts, wall molding,space/stabilizer bars, hanger wire & attachment devices | Included | Included | Included | Included | Included | Included |
| Include Compression struts per 2/A-540 | Included | Included | Included | Included | Included | Included |
| Read and abide by all Notes on sheet | Included | Included | Included | Included | Included | Included |
| Safety walk and progressive cleanup | 2,320 | 2,320 | 2,320 | 2,320 | 2,320 | 2,320 |
| Include extra hanger wires for lighting fixtures, hvac registers & diffusers | 600 | 600 | 600 | 600 | Included | Included |
| ACT Panel w/ "L" moulding on face of soffit at ceiling ht change per 2/A-501 | Included | Included | Included | Included | Included | Included |
| Acoustical Wall Panels | | | | | | |
| Spec provided in RFI#7 - Acoustical Wall Panels 09 8434 | 34,660 | 34,660 | 34,660 | 34,660 | 24,400 | 34,660 |
| AWP Type 1, Keynote 10.54 | | | | | Included | |
| MFR - Guilford FR-701 screen fabric, pattern 2100, 1" Thickness, 16.0+/ly weight | | | | | Included | |
| Tackable Wall Panels | | | | | 10,000 | |
| Finish Schedule A-612: | | | | | Included | |

Bid Evaluation Report

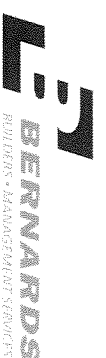

Acoustical Ceilings

Marshall Classroom Building

| Description | Alert Insulation | Subcontractors | | | Prime Acoustics | Hamilton Ceiling Systems |
|--|------------------|------------------|----------------------|---------------|-------------------|--------------------------|
| | | Standard Drywall | Commercial Interiors | CG Chaney | | |
| W5-Tackboard panel over gypsum board, Keynote 10.50 | | | | | Included | |
| Color (not listed) provide per MFR standard color palette | | | | | Included | |
| Acoustical panels to be semi-rigid inorganic glass fiber material by Owens Corning, Johns Manville, Knauf or equal | | | | | Included | |
| Thickness of panels per Sound absorption coefficient requirement per tabulated values 09 8434,1.03,D | | | | | Included | |
| Provide cutouts in panels for plates, receptacles, outlets, switches, tstats, clocks, lights, etc. | | | | | Included | |
| Include all mounting hardware, concealed types, individually removable | | | | | Included | |
| See the Typical Room Layouts for Learning Labs, Science Classrooms & Performing Arts Lab - 1,2,3/A410 | | | | | Included | |
| Interior elevations at classrooms A-220 | | | | | Included | |
| Tackboard Floor to Ceiling see 3/A-530 | | | | | Included | |
| Detail 3/A530 shows a 5/8" Corkboard cover with wall covering & alum edge piece 14 ga. Min entire perimeter | | | | | Included | |
| Installed directly over drywall walls | | | | | Included (24,400) | |
| ARC:5 | | | | | | |
| TOTALS | 79,080 | 90,610 | 80,070 | 73,355 | 48,320 | 80,680 |
| Recommendation: | Amount | | | | | |
| Prime Acoustics | 48,320 | | | | | |

Bid Evaluation Report

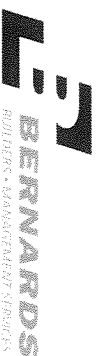

Acoustical Ceilings

Marshall Classroom Building

Subcontractors

| Description | Ceiling Experts | Call-USA | Nelson Adams Naco | Tech-Wall | Job Number | 1641 |
|---|-----------------|-------------|-------------------|-----------|--------------|-----------|
| | | | | | Bid Date | 6/7/2017 |
| | | | | | Date Printed | 7/27/2017 |
| Base Bid | 65,000 | 39,982 | AWP Only | AWP Only | | |
| Spec #: 09 5123 - Acoustical Tile Ceilings | N/A | Included | N/A | N/A | | |
| | Included | Included | Included | Included | | |
| Furnished, Installed, FOB Jobsite, Tax Included | Included | Included | Included | Included | | |
| Plans and Specs Dated: 1/28/2016 & 10/4/2016 | Included | Included | Included | Included | | |
| Acknowledgment of RFI's 1-75 dated 6.5.17 | Included | Included | Included | Included | | |
| Bid Good for 60 Days | Included | 30 Days | Included | Included | | |
| Prevailing Wage | Included | Included | Included | Included | | |
| Prequalified per Oxnard School District Standards | N/A | N/A | N/A | N/A | | |
| Attachment C Acknowledgement | N/A | N/A | N/A | N/A | | |
| | | | | | | |
| Acoustical Panel Ceilings | | | | | | |
| Reflected Ceiling Plans A-121 to A-122 | Included | Included | | | | |
| | Included | Included | | | | |
| Finish Schedule A-612, ACT-1 in Classrooms as listed | Included | Included | | | | |
| MFR - Armstrong, CertainTeed or USG | Armstrong | CertainTeed | | | | |
| Armstrong Fine Fissured, White, No Pattern, 3/4" Thick 24"x48" | Included | Included | | | | |
| | Included | Included | | | | |
| Grid - Prelude XL 15/16" Exposed Tee by Armstrong | Included | Included | | | | |
| | Included | Included | | | | |
| ACT Details per A-540 | Included | Included | | | | |
| Include vertical struts, wall molding,space/stabilizer bars, hanger wire & attachment devices | Included | Included | | | | |
| | Included | Included | | | | |
| Include Compression struts per 2/A-540 | Included | Included | | | | |
| Read and abide by all Notes on sheet | Included | Included | | | | |
| | | | | | | |
| Include extra hanger wires for lighting fixtures, hvac registers & diffusers | 600 | 600 | | | | |
| ACT Panel w/ "L" moulding on face of soffit at ceiling ht change per 2/A-501 | Included | Included | | | | |
| 0 | | | | | | |
| Acoustical Wall Panels | | | | | | |
| Spec provided in RFI#7 - Acoustical Wall Panels 09 8434 | 85,000 | 56,448 | 16,736 | 25,084 | | |
| | Included | Included | Included | Included | | |
| AWP Type 1, Keynote 10.54 | Included | Included | Included | Included | | |
| MFR - Guilford FR-701 screen fabric, pattern 2100, 1" Thickness, 16.0+ /ly weight | Included | Included | 9,000 | Included | | |
| Tackable Wall Panels | 10,000 | 10,000 | 10,000 | 9,576 | | |
| Finish Schedule A-612: | Included | Included | Included | Included | | |

Bid Evaluation Report



Acoustical Ceilings

Marshall Classroom Building

Subcontractors

| Description | Ceiling Experts | Call-USA | Subcontractors | | Tech-Wall | Job Number | 1641 |
|--|-----------------|----------------|-------------------|-----------------|-----------|--------------|-----------|
| | | | Nelson Adams Naco | | | Bid Date | 6/7/2017 |
| | | | | | | Date Printed | 7/27/2017 |
| W5-Tackboard panel over gypsum board, Keynote 10.50 | Included | Included | Included | Included | Included | | |
| Color (not listed) provide per MFR standard color palette | Included | Included | Included | Included | Included | | |
| Acoustical panels to be semi-rigid inorganic glass fiber material by Owens Corning, Johns Manville, Knauf or equal | Included | Included | Included | Included | Included | | |
| Thickness of panels per Sound absorption coefficient requirement per tabulated values 09 8434,1.03,D | Included | Included | Included | Included | Included | | |
| Provide cutouts in panels for plates, receptacles, outlets, switches, tstats, clocks, lights, etc. | Included | Included | Included | Included | Included | | |
| Include all mounting hardware, concealed types, individually removable | Included | Included | Included | Included | Included | | |
| See the Typical Room Layouts for Learning Labs, Science Classrooms & Performing Arts Lab - 1,2,3/A410 | Included | Included | Included | Included | Included | | |
| Interior elevations at classrooms A-220 | Included | Included | Included | Included | Included | | |
| Tackboard Floor to Ceiling see 3/A-530 | Included | Included | Included | Included | Included | | |
| Detail 3/A530 shows a 5/8" Corkboard cover with wall covering & alum edge piece 14 ga. Min entire perimeter | Included | Included | Included | Included | Included | | |
| Installed directly over drywall walls | Included | Included | Included | Included | Included | | |
| ARC.5 | | | | | | | |
| TOTALS | 160,600 | 107,030 | 35,736 | 34,660 | 0 | 0 | 0 |
| | | | AWP Only | AWP Only | | | |
| Recommendation: | Amount | | | | | | |
| Prime Acoustics | 48,320 | | | | | | |

Bid Evaluation Report

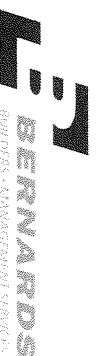

Carpet & Resilient Flooring

Marshall Classroom Building

Subcontractors

Job Number **1641**
 Bid Date **6/7/2017**
 Date Printed **7/27/2017**

| Description | Subcontractors | | | | Job Number | Bid Date | Date Printed |
|--|-------------------|---------------|--------------------|----------------------|------------|----------|--------------|
| | Reliable Flooring | JJJ Flooring | Floor Tech America | Continental Flooring | | | |
| Base Bid | 59,951 | 64,560 | 76,887 | 65,126 | | | |
| Spec #: 09 6513 - Rubber Base | Included | Included | Included | Included | | | |
| Spec #: 09 6519 - Resilient Tile Flooring | Included | Included | Included | Included | | | |
| Furnished, Installed, FOB Jobsite, Tax Included | Included | Included | Included | Included | | | |
| Plans and Specs Dated: 1/28/2016 & 10/4/2016 | Included | Included | Included | Included | | | |
| Acknowledgment of RFIs 1-75 dated 6.5.17 | Included | Included | Included | Included | | | |
| Bid Good for 60 Days | 30 Days | Included | Included | Included | | | |
| Prevailing Wage | Included | Included | Included | Included | | | |
| Prequalified per Oxnard School District Standards | N/A | N/A | N/A | N/A | | | |
| Attachment C Acknowledgement | N/A | N/A | N/A | N/A | | | |
| Flooring | | | | | | | |
| Minor Floor Prep | Included | Included | Included | Included | | | |
| Testing for PH and Moisture | Included | Included | Included | Included | | | |
| Remediation if Applicable | Included | Included | Included | Included | | | |
| Resilient Flooring and Rubber Base | | | | | | | |
| Finish Schedule A-612, F2-Linoleum Tile, B1-4" Vinyl Resilient Base | Included | Included | Included | Included | | | |
| MFR - Forbo, Marmoleum Composition Tile (MCT) 13"x13", 2mm thk, pattern & color by Architect | Included | Included | Included | Included | | | |
| Include all adhesives & sealants | Included | Included | Included | Included | | | |
| Heat-welding of seams with color-matched color rods | 6,700 | 6,700 | 6,700 | 6,700 | | | |
| Resilient Base - Rubber, Cove, 4", preformed inside & outside corners | Included | Included | Included | Included | | | |
| MRF - Burke/Mercer, Roppe/Pinnacle, Flexco or equal | Included | Included | Included | Included | | | |
| F2 at All Classrooms | Included | Included | Included | Included | | | |
| B1 at All Classrooms, storage, back of house rooms | Included | Included | Included | Included | | | |
| F2 MCT in Elevator Cab (not listed but include) | 640 | 640 | 640 | 640 | | | |
| Include cleaning of floors after installation per specs | Included | Included | Included | Included | | | |
| Safety walk and progressive cleanup | 2,320 | 2,320 | 2,320 | 2,320 | | | |
| Include initial maintenance "starter kit" from manufacturer and conducted (1st time) by flooring sub spec 3.08.B | Included | Included | Included | Included | | | |
| Include protection of floors after installation per specs | Included | Included | Included | Included | | | |
| TOTALS | 69,611 | 74,220 | 86,547 | 74,786 | 0 | 0 | |
| Recommendation: | Amount | | | | | | |
| Reliable Flooring | 69,611 | | | | | | |

Bid Evaluation Report

Painting

Marshall Classroom Building

| Description | Subcontractors | | | | Job Number | Date Printed | Valley Painting |
|---|------------------|------------------|------------------|------------------|------------|--------------|-----------------|
| | Vanguard | Borbon Inc | Triumph Painting | Prime Painting | | | |
| Base Bid | 53,100 | 102,000 | 155,800 | 185,000 | 0 | 0 | |
| Spec #: 07 9200 - Joint Sealants | Included | Included | Included | Included | | | |
| Spec #: 09 9000 - Paints and Coatings | Included | Included | Included | Included | | | |
| Furnished, Installed, FOB Jobsite, Tax Included | Included | Included | Included | Included | | | |
| Plans and Specs Dated: 1/28/2016 & 10/4/2016 | Included | Included | Included | Included | | | |
| Acknowledgment of RFI's 1-75 dated 6.5.17 | Included | Included | Included | Included | | | |
| Bid Good for 60 Days | Included | Included | 90 Days | Included | | | |
| Prevailing Wage | Included | Included | Included | Included | | | |
| Prequalified per Oxnard School District Standards | N/A | N/A | N/A | N/A | | | |
| Attachment C Acknowledgement | N/A | N/A | N/A | N/A | | | |
| Painting and Coating | | | | | | | |
| BOD - Dunn Edwards or Equal | Included | Included | Included | Included | | | |
| Colors TBD | Included | Included | Included | Included | | | |
| Finish Schedule A-612: | Included | Included | Included | Included | | | |
| F1-Sealed Concrete | w/ waterproofing | w/ waterproofing | w/ waterproofing | w/ waterproofing | | | |
| P1-Interior Semi-Gloss Paint | Included | Included | Included | Included | | | |
| P2-Interior Gloss Paint | Included | Included | Included | Included | | | |
| P3-Clear Sealant | Included | Included | Included | Included | | | |
| (3) Top Coats and (1) Coat Primer | Included | Included | Included | Included | | | |
| Exterior Plaster Walls & Soffits - 4 coats | Included | Included | Included | Included | | | |
| Interior Walls, Soffits and Ceilings, 4 coats | Included | Included | Included | Included | | | |
| Exterior & Interior HM Door Frames, 3 coats | Included | Included | Included | Included | | | |
| Exterior & Interior HM Doors, 3 coats | Included | Included | Included | Included | | | |
| Exterior & Interior Wood Doors, 4 coats | Included | Included | Included | Included | | | |
| All Exposed Steel to be Primed with Zinc Coating to Receive Paint (RFI #38) | Included | Included | Included | Included | | | |
| Paint Steel Stair Pans, Columns, Stringers, Guardrails and Handrails (RFI #38) | Included | Included | Included | Included | | | |
| All Exposed Metal on Roof to be Galvanized per Spec, No Paint Finish (RFI #47) | Included | Included | Included | Included | | | |
| Etching galvanized guardrails, handrails & stairs prior to painting | Included | Included | Included | Included | | | |
| Insulated and Exposed Pipes, Ducts, Conduit, Hangers, Brackets, Collars and Supports, Mechanical and Electrical Equipment | Included | Included | Included | Included | | | |
| Shop-Primed Items | Included | Included | Included | Included | | | |
| High Performance Coating at Ext. Hand and Guardrails | Not Included | Not Included | Not Included | Not Included | | | |
| Exterior Stairs Shop Primed and Painted | Included | Included | Included | Included | | | |
| HSS Steel at Ext. exposed Columns & Beams | Included | Included | Included | Included | | | |
| Cleanup of all your work | Included | Included | Included | Included | | | |
| Touch-Up Painting Allowance | 5,092 | 5,092 | 5,092 | 5,092 | | | |

Bid Evaluation Report

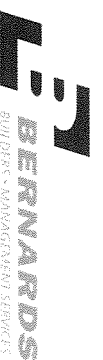

Painting

Marshall Classroom Building

Subcontractors

| Description | Subcontractors | | | | Job Number | 1641 |
|------------------------------|----------------|----------------|------------------|----------------|--------------|-----------|
| | Vanguard | Borbon Inc | Triumph Painting | Prime Painting | Date Printed | 6/7/2017 |
| Joint Sealant Work Allowance | 2,500 | 2,500 | 2,500 | 2,500 | 7/27/2017 | 7/27/2017 |
| Hedge | 26,800 | | | | | |
| ARC:1 | 2,000 | 2,000 | 2,000 | 2,000 | | |
| ARC:4 | 10,700 | 11,000 | 11,000 | 11,000 | | |
| ARC:5 | 3,000 | 3,000 | 3,000 | 3,000 | | |
| ARC:17 | (1,000) | (1,000) | (1,000) | (1,000) | | |
| TOTALS | 102,192 | 124,592 | 178,392 | 207,592 | 0 | 0 |
| Recommendation: | Amount | | | | | |
| Vanguard | 102,192 | | | | | |

Bid Evaluation Report

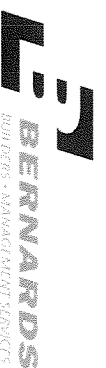

Building Specialties

Marshall Classroom Building

Job Number **1641**
 Bid Date **6/7/2017**
 Date Printed **7/27/2017**
 Bids Received

| Div | Description | Amount | Recommended Subcontractor | Bids Received |
|-----------------|---|-------------|------------------------------|---------------|
| 10 44 00 | Fire Extinguishers & Specialties | 3,045 | BL Wilcox (\$3,045 Supplier) | 3 |
| | See sheet A-111 & A-112 for locations of FEC | Included | Inland Empire (\$5,300) | |
| | 1st fl Keynote 10.51 - Fire Extinguisher Cabinet | Included | John Pence (\$4,800) | |
| | Semi-Recessed, see 6&7/A-530 | | | |
| | 2nd fl Keynote 10.55 - Fire Extinguisher Cabinet | Included | | |
| | Semi-Recessed, see 6&7/A-530 | | | |
| | 1st Fl (8 ea) | Included | | |
| | 2nd Fl (1 ea) | Included | | |
| | Provide rated cabinet at rated wall per note on 7/A-530 | Included | | |
| | Semi Recessed FEC Max. Projection 4" (RFI #32) | | | |
| 10 50 50 | Lockers | 46,600 | Inland Empire | 1 |
| | Added Spec Section in RFI #9 - Section 10505 dated 5/23/2017 | Included | | |
| | See Accessible Locker Calculations on sheet A-411, total of 8 | Included | | |
| | MFR - DeBourgh Manufacturing Co. or equal | Included | | |
| | Interior Elevations A-224, see Keynotes | Included | | |
| | 12.10 - 12"x12" triple stack locker, see 13/A-530 | Included | | |
| | 12.13 - Accessible locker, see 13/A-530 | Included | | |
| | 12.31 - 20"x48" Accessible Locker room bench (handwritten on bottom of keynotes legend) | Included | | |
| | 1-Tier Lockers per detail 13/A-530 - None shown | Included | | |
| | 2-Tier Lockers per detail 13/A-530 - None shown | Included | | |
| | 3-Tier Lockers per 13/A-530 | Included | | |
| | At Boys Changing Room - 1/A-411, total of 32, 3-tier | Included | | |
| | Accessible at Boys Changing Room - 1/A-411, total of 1 ea | Included | | |
| | At Girls Changing Room - 1/A-411, total of 32, 3-tier | Included | | |
| | Accessible at Girls Changing Room - 1/A-411, total of 1 ea | Included | | |
| | Include Locker base at stud wall installation per 15/A-530 | Included | | |
| | Coordinate blocking & backing w/ Framer | Included | | |
| | At concrete slab use anchor bolts per detail 3/8" dia 3" embedment | Included | | |
| | 6" Upturned C/P concrete base w/ tooled radius at lockers - 14 & 15/A-530 | w/ Concrete | | |

Bid Evaluation Report



Building Specialties

Marshall Classroom Building

Job Number **1641**
Bid Date **6/7/2017**
Date Printed **7/27/2017**

| Div | Description | Amount | Recommended Subcontractor | Bids Received | |
|-----|--|---------------|---------------------------|---------------|--|
| | | | | | |
| N/A | Misc Site Furnishings | 0 | Bernards | | |
| | None Noted | | | | |
| N/A | Misc Equipment (TV's) | 6,000 | Bernards | | |
| | TV Wall Brackets - 1/A-531 | Included | | | |
| | MFR not listed, size is 2'-5"X2' | Included | | | |
| | Furnished | by District | | | |
| | Installed | Included | | | |
| | Coordinate blocking & backing w/ framing sub | Included | | | |
| | TV's in Classrooms | by District | | | |
| | 60" Flat Screen by District | by District | | | |
| | Final hook-up, connection to Teachers computer | by District | | | |
| | Total | 55,645 | | | |

Bid Evaluation Report



Visual Display Boards

Marshall Classroom Building

Subcontractors

Job Number 1641
 Bid Date 6/7/2017
 Date Printed 7/27/2017

| Description | ABC School Equipment | | Nelson Adams Naco Inc. | | 0 | 0 | 0 | 0 |
|--|----------------------|----------------|------------------------|----------------|----------|----------|----------|----------|
| | Included | 275,308 | Included | 208,582 | | | | |
| Base Bid | Included | 275,308 | Included | 208,582 | 0 | 0 | 0 | 0 |
| Spec #: 101101 | Included | | Included | | | | | |
| Spec #: | | | | | | | | |
| Furnished, Installed, FOB Jobsite, Tax Included | Included | | Included | | | | | |
| Plans and Specs Dated: 1/28/2016 & 10/4/2016 | Included | | Included | | | | | |
| Acknowledgment of RFT's 1-75 dated 6.5.17 | Included | | Included | | | | | |
| Bid Good for 60 Days | 60 Days | | Included | | | | | |
| Prevailing Wage | Included | | Included | | | | | |
| Pregualified per Oxnard School District Standards | N/A | | N/A | | | | | |
| Attachment C Acknowledgement | N/A | | N/A | | | | | |
| Visual Display Boards | | | | | | | | |
| Finish Schedule A-612: | Included | | Included | | | | | |
| W4 - Marker Board Panel over gypsum board | Included | | Included | | | | | |
| Interior Elevations sheets A-220 to A-223 | Included | | Included | | | | | |
| Keynote 10.52-Markerboard Surface from floor to ceiling, Standard panel size 5'x10' | Included | | Included | | | | | |
| Keynote 12.26 - 3'-2"x10' Sliding Marker Board, see 10/A-530 | Included | | Included | | | | | |
| Keynote 12.27 - (2) 2'-8"x10' Sliding Marker Boards, see 10/A-530 | Included | | Included | | | | | |
| MFR - MooreCo, Claridge or Polyvision or Equal | Platinum Visual | | Nelson Adams Naco | | | | | |
| There is a Marker Board Sliding Door Schedule listing all the rooms to receive them on A-610 | Included | | Included | | | | | |
| Horizontal Sliding Unit Wall System Assembly per 10/A-530 | Included | | Included | | | | | |
| Furnished AND Installed | Included | | Included | | | | | |
| First Floor Classrooms - total of 19 each | Included | | Included | | | | | |
| Second Floor Classrooms - total of 23 each | Included | | Included | | | | | |
| ARC.4 | (60,500) | | (60,223) | | | | | |
| TOTALS | | 214,808 | | 148,359 | 0 | 0 | 0 | 0 |
| Recommendation: | | Amount | | | | | | |
| Nelson Adams Naco Inc. | | 148,359 | | | | | | |

Bid Evaluation Report



Signage

Marshall Classroom Building

Subcontractors

Job Number **1641**
 Bid Date **6/7/2017**
 Date Printed **7/27/2017**

| Description | AGS | Subcontractors | | | Braille Signs, INC | Job Number | Bid Date | Date Printed |
|--|---------------|-----------------------|---------------|---------------|--------------------|------------|----------|--------------|
| | | John Pence Bldg Spec. | CA Signs | | | | | |
| Base Bid | 6,150 | 10,130 | 11,471 | 15,302 | | | | |
| Spec #: 10 1400 - Signage | Included | Included | Included | Included | | | | 0 |
| Spec #: | | | | | | | | 0 |
| Furnished, Installed, FOB Jobsite, Tax Included | Included | Included | Included | Included | | | | |
| Plans and Specs Dated: 1/28/2016 & 10/4/2016 | Included | Included | Included | Included | | | | |
| Acknowledgment of RFIs 1-75 dated 6.5.17 | Included | Included | Included | Included | | | | |
| Bid Good for 60 Days | Included | Included | Included | Included | | | | |
| Prevailing Wage | Included | Included | Included | Included | | | | |
| Prequalified per Oxnard School District Standards | N/A | N/A | N/A | N/A | | | | |
| Attachment C Acknowledgement | N/A | N/A | N/A | N/A | | | | |
| Signage | Included | Included | Included | Included | | | | |
| Signage at Each Bldg per Floor Plans and Elevations | Included | Included | Included | Included | | | | |
| Signage & Fire Extinguisher Plans - G-006 | Included | Included | Included | Included | | | | |
| Signage Details sheet - A-550 | Included | Included | Included | Included | | | | |
| Room Signs - 1/A-550 | Included | Included | Included | Included | | | | |
| Toilet room door signage - 3/A-550 | Included | Included | Included | Included | | | | |
| Fire Riser door signage - 5/A-550 | 200 | Included | Included | Included | | | | |
| Exit Signs - 6,7,8/A-550 | Included | Included | Included | Included | | | | |
| Typical Classroom I.S.A signage - 9/A-550 | Included | Included | Included | Included | | | | |
| Restroom Signs - Girls, Boys, Unisex, Staff - Wall & Door signage 3,11,13,14/A-550 | Included | Included | Included | Included | | | | |
| Fire Alarm Panel Control - 12/A550 | Included | Included | Included | Included | | | | |
| Electrical & Not an exit signage 15/A-550 | Included | Included | Included | Included | | | | |
| Maximum occupancy signage - 16/A550 | Included | Included | Included | Included | | | | |
| Stenciling on Rated Walls Signage - 19/A-550 | w/ Drywall | w/ Drywall | w/ Drywall | w/ Drywall | | | | |
| Warning sign - 20/A-550 | 300 | Included | Included | Included | | | | |
| Fire Extinguisher Signage - 6/A-530, G-006 (17 ea) | 2,975 | Included | Included | Included | | | | |
| Assistive Listening Signage | 250 | Included | Included | Included | | | | |
| ADA Signage | Included | Included | Included | Included | | | | |
| Ext. Aluminum Letters, or Painted Bldg # (No Callouts on Elevations) | 750 | 750 | 750 | 750 | | | | |
| See Spec Section for several other signs as required | Included | Included | Included | Included | | | | |
| Site Signage at Fire Lane shown on Site Plan A-101 | w/ Striping | w/ Striping | w/ Striping | w/ Striping | | | | |
| Site Signage at Re-Striped existing parking lot shown on A-102, 104, 105 | w/ Striping | w/ Striping | w/ Striping | w/ Striping | | | | |
| Temporary project signage | 2,000 | 2,000 | 2,000 | 2,000 | | | | |
| TOTALS | 12,625 | 12,880 | 17,196 | 18,302 | | | | 0 |
| Recommendation: | Amount | | | | | | | 0 |
| AGS | 12,625 | | | | | | | |

Bid Evaluation Report



Toilet Compartments & Accessories

Marshall Classroom Building

Subcontractors

| Description | Subcontractors | | | | Job Number | Date Printed |
|--|--------------------|----------------------|-----------------------|----------------|------------|--------------|
| | Inland Empire Arch | YTI Enterprises | John Pence Bldg Spec. | Stumbaugh | | |
| Base Bid | 31,400 | 23,200 | 30,700 | 34,192 | 1641 | 6/17/2017 |
| Spec #: 10 2113.17 - Phenolic-Core Shower & Dressing Compartments | Included | Included | Included | Included | | 7/27/2017 |
| Spec #: 10 2800 - Toilet Accessories | Included | Included | Included | Included | | |
| Furnished, Installed, FOB Jobsite, Tax Included | Included | Included | Included | Included | | |
| Plans and Specs Dated: 1/28/2016 & 10/4/2016 | Included | Included | Included | Included | | |
| Acknowledgment of RFIs 1-75 dated 6.5.17 | Included | Included | Included | Included | | |
| Bid Good for 60 Days | 30 Days | Included | Included | Included | | |
| Prevailing Wage | Included | Included | Included | Included | | |
| Prequalified per Oxnard School District Standards | N/A | N/A | N/A | N/A | | |
| Attachment C Acknowledgement | N/A | N/A | N/A | N/A | | |
| Toilet Compartments | Included | Included | Included | Included | | |
| Solid Phenolic MFR by Formica, Trespa, Pionite ore equal | Accutec | Included | Included | Included | | |
| Galaxy hardware, Series 8033 | Included | Included | Included | Included | | |
| Fire Rated Class B for ASTM E84 | Included | Included | Included | Included | | |
| Overhead braced | Included | Included | Included | Included | | |
| Accessible compartments | Included | Included | Included | Included | | |
| Standard compartments | Included | Included | Included | Included | | |
| Urinal Screens | Included | Included | Included | Included | | |
| Vestibule Screens | Included | Included | Included | Included | | |
| No colors selected, include standard color palette in your bid | Formica Sparkle | Formica or Wilsonart | Black | Standard Color | | |
| Toilet Accessories | Included | Included | Included | Included | | |
| MFR - Bobrick or approved equal | Included | Included | Included | Included | | |
| Interior Elevations A-224, see Keynotes | Included | Included | Included | Included | | |
| 10.03 - Tactile room name & number signage 1/A-550 | w/ Signage | w/ Signage | w/ Signage | w/ Signage | | |
| 10.03 - Toilet room door signage 3/A-550 | w/ Signage | w/ Signage | w/ Signage | w/ Signage | | |
| 10.32 - Paper towel dispenser & Waste receptacle 1/A-535 | Included | Included | Included | Included | | |
| 10.33 - Surface mounted soap dispenser 1/A-5353, B-211 | Included | Included | Included | Included | | |
| 10.34 - Multi-roll toilet tissue dispenser, semi recessed 1/A-5353, B-3888 | Included | Included | Included | Included | | |
| 10.36 - Grab bar - 1, 8 & 10/A-5353, B-6806 series, length per drawing | Included | Included | Included | Included | | |
| 10.37 - Seat cover dispenser 1/A-5353, B-221 | Included | Included | Included | Included | | |
| 10.39 - Mirror 18"x30" 1/A-5353, B-292 | Included | Included | Included | Included | | |
| 10.41 - Accessible side toilet stall 11/A-5353 | Included | Included | Included | Included | | |
| Janitor Closet Accessories | Included | Included | Included | Included | | |

Bid Evaluation Report

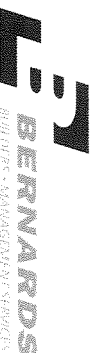

Toilet Compartments & Accessories

Marshall Classroom Building

Subcontractors

Job Number 1641
 Bid Date 6/7/2017
 Date Printed 7/27/2017

| Description | Subcontractors | | | | Amount |
|---|----------------------|-----------------|-----------------------|---------------|----------|
| | Inland Empire Arch | YTI Enterprises | John Pence Bldg Spec. | Stumbaugh | |
| Mop & Broom Holder (4 Holders) B-223 x 36" | Included | Included | Included | Included | |
| Not Keynoted, but listed in Spec Section: | | | | | |
| Hand Dryer, World Dryer Model XRA | 4,200 | 4,200 | 4,200 | Included | |
| Sanitary Napkin Disposal, Recessed B-353 or Partition Mounted B-354 | Included | 4,800 | Included | Included | |
| Sanitary Napkin Dispenser, Recessed B-3706 25 | 1,000 | 1,000 | 1,000 | 1,000 | |
| Keys at locked dispensing units, keyed alike | Included | Included | Included | Included | |
| Other Potential Items: | | | | | |
| Backpack Hooks in Rooms | Excluded | Excluded | Excluded | Excluded | |
| ARC.14 | (4,200) | (4,200) | (4,200) | (4,200) | |
| TOTALS | 32,400 | 29,000 | 31,700 | 30,992 | 0 |
| Recommendation: | | | | | |
| YTI Enterprises | Amount 29,000 | | | | |

Bid Evaluation Report



Window Coverings

Marshall Classroom Building

Subcontractors

| Description | Subcontractors | | | | Job Number | Date Printed |
|--|-------------------|-----------------|----------------|--------------------|---------------|--------------|
| | A1 Quality Blinds | Digital Decora | Contract Décor | Diversified Window | | |
| Base Bid | 10,000 | 15,440 | 16,340 | 21,248 | 1641 | 6/7/2017 |
| Spec #: 12 2413 - Roller Window Shades | | | | | | 7/27/2017 |
| Furnished, Installed, FOB Jobsite, Tax Included | Included | Included | Included | Included | Included | |
| Plans and Specs Dated: 1/28/2016 & 10/4/2016 | Included | Included | Included | Included | Included | |
| Acknowledgment of RFIs 1-75 dated 6.5.17 | Included | Included | Included | Included | Included | |
| Bid Good for 60 Days | 90 Days | Included | 90 Days | 90 Days | 90 Days | |
| Prevailing Wage | Included | Included | Included | Included | Included | |
| Pregualified per Oxnard School District Standards | N/A | N/A | N/A | N/A | N/A | |
| Attachment C Acknowledgement | N/A | N/A | N/A | N/A | N/A | |
| Window Coverings | Included | Included | Included | Included | Included | |
| MFR - Levelor, HD, Spring | Included | Included | Included | Included | Included | |
| New Classroom Building | Included | Included | Included | Included | Included | |
| All Windows Interior and Exterior | Included | Included | Included | Included | Included | |
| Motor Operated (Where Shown) | Excluded | Excluded | Excluded | Excluded | Excluded | |
| MFR - ElectroShade by Mechoshade Systems or approved equal | Excluded | Excluded | Excluded | Excluded | Excluded | |
| Manual Operated at all windows | Included | Included | Included | Included | Included | |
| MFR - Mechno/5 by Mechoshade Systems or approved equal | Hunter Douglass | Lutron Contract | FlexShades | Included | Included | |
| Provide a complete operated system including fabric, mounting spline, end caps, fascia, filters, side channels, center channels, anchors and fasteners | Included | Included | Included | Included | Included | |
| Fabric "AV Blackout shade my Mechoshade or equal | Included | Included | Included | Included | Included | |
| TOTALS | 10,000 | 15,440 | 16,340 | 21,248 | 27,860 | 0 |
| Recommendation: | Amount | | | | | |
| A1 Quality Blinds | 10,000 | | | | | |
| Alternates | | | | | | |
| RFI #25 | | | | | | |
| Alt #1: Manual Roller Shades at Larger Sectional Doors at Classrooms | 9,000 | 12,628 | 20,820 | Excluded | 20,820 | |
| Alt #2: ADD for Motorized Roller Shades at Larger Sectional Doors at Classrooms | 13,500 | 37,552 | 41,930 | Excluded | 41,930 | |

Bid Evaluation Report

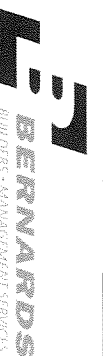

Final Cleaning

Marshall Classroom Building

Subcontractors

| Description | Subcontractors | | | Job Number | 1641 |
|--|------------------------|--------------------------|---------------------------|--------------|-----------|
| | AAA Express Janitorial | All-Pro Bidg Maintenance | Commercial Const Cleaning | Bid Date | 6/7/2017 |
| | | | | Date Printed | 7/27/2017 |
| Base Bid | 2,700 | 28,760 | 22,550 | | |
| Spec #: N/A | N/A | N/A | N/A | | |
| Furnished, Installed, FOB jobsite, Tax Included | Included | Included | Included | | |
| Plans and Specs Dated: 1/28/2016 & 10/4/2016 | Included | Included | Included | | |
| Acknowledgment of RFIs 1-75 dated 6.5.17 | Included | Included | Included | | |
| Bid Good for 60 Days | Included | Included | Included | | |
| Prevailing Wage | Included | Included | Included | | |
| Prequalified per Oxnard School District Standards | Included | N/A | N/A | | |
| Attachment C Acknowledgement | Included | N/A | N/A | | |
| Final Construction Cleaning | | | | | |
| Provide all safety equipment, hard hats, gloves, eye protection & vest | Included | Included | Included | | |
| Include all cleaning tools, ladders, mops, brooms, towels, etc. | Included | Included | Included | | |
| Clean elevator, inside & out | 500 | Included | Included | | |
| Clean interior windows & mullions | Included | Included | Included | | |
| Clean exterior windows | 3,500 | Included | Included | | |
| Clean all cabinets, counter & millwork | Included | Included | Included | | |
| Clean inside cabinets & drawers, shelves, bookcases | 1,500 | Included | Included | | |
| Clean all door frames, hardware & kick-plates | Included | Included | Included | | |
| Wipe clean baseboards | Included | Included | Included | | |
| Wipe clean lights & T-bar ceiling (as required) | Included | Included | Included | | |
| Vacuum all carpeted areas | Included | Included | Included | | |
| Clean all air return grills | Included | Included | Included | | |
| Clean all items attached to walls-FEC, MEP devices, signage marker bds, etc. | 1,500 | Included | Included | | |
| Wipe, clean mech & elec rms equip, ductwork, conduit & piping | 1,500 | Included | Included | | |
| Clean Boy's & Girl's restrooms & locker rooms | Included | Included | Included | | |
| Clean plumbing fixtures, toilet part, sinks, mirrors, tops, toilets, lockers, etc. | 2,500 | Included | Included | | |
| Clean tile floors & walls | 2,500 | Included | Included | | |
| Sweep & mop all floors | Included | Included | Included | | |
| Wax, 3-coat, all VCT floors | 2,500 | Included | Included | | |
| Sweep & mop all exterior walkways, corridors, stairways & gurradrails | 2,500 | Included | Included | | |
| Sweep & power wash ext bldg walks, sidewalk & hardscape | 3,500 | Included | 3,500 | | |

Bid Evaluation Report

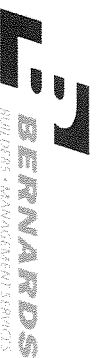

Final Cleaning

Marshall Classroom Building

Subcontractors

| Description | AAA Express Janitorial | All-Pro Bldg Maintenance | Commercial Const. Cleaning | Job Number | 1641 |
|------------------------------------|------------------------|--------------------------|----------------------------|--------------|-----------|
| | | | | | Bid Date |
| | | | | Date Printed | 7/27/2017 |
| Prevailing Wage rates requirements | 5,000 | Included | Included | | |
| T&M rate per employee | | | \$79.80/hr | | |
| TOTALS | 29,700 | 28,760 | 26,050 | 0 | 0 |
| Recommendation: | | Amount | | | |
| Commercial Const Cleaning | | 26,050 | | | |

Bid Evaluation Report



Elevators

Marshall Classroom Building

Subcontractors

Job Number **1641**
 Bid Date **6/7/2017**
 Date Printed **7/27/2017**

| Description | Kone, Inc. | Republic Elevator | | | | |
|---|-----------------|---------------------|----------|----------|----------|----------|
| | | | Amount | | | |
| Base Bid | 195,850 | ALT: \$89,860 | | | | |
| Spec #: 14 2123 - Machine-Room-Less Electric Traction Passenger Elevators | Included | No Use Hydro | | | | |
| Bond Rate | Bond at | Bond at | | | | |
| Furnished, Installed, FOB Jobsite, Tax Included | Included | Included | | | | |
| Plans and Specs Dated: 1/28/2016 & 10/4/2016 | Included | Included | | | | |
| Acknowledgment of RFIs 1-75 dated 6.5.17 | Included | Included | | | | |
| Bid Good for 60 Days | 30 Days | 60 days | | | | |
| Prevailing Wage | Included | Included | | | | |
| Prequalified per Oxnard School District Standards | N/A | N/A | | | | |
| Attachment C Acknowledgement | N/A | N/A | | | | |
| Elevators | | | | | | |
| Deferred Approval - Elevator Guide Rails, G-001 | Included | Included | | | | |
| MFR, BOD - Kone EcoSpace Gearless Traction Elevator | Included | Twin Jack, Holeless | | | | |
| Hoist Beam, Guide Rails per specs | w/ Steel | w/ Steel | | | | |
| Pit ladder 13/A-561, notes states by Elev Mfr | w/ Steel | w/ Steel | | | | |
| Continuous plate PL 3/16"x3" cont across hoistway 5&7/A-561 | w/ Steel | w/ Steel | | | | |
| Bldg I - New Classroom Building | Included | Included | | | | |
| Elevator No. 1: 3500#, 150ft/min, 2 Stops, 2 Openings per Specs | Included | Included | | | | |
| Includes all info for Elevator Details shown on sheet A-561 | Included | Included | | | | |
| Cab Interior Finishes - brushed SS at walls, front & doors w/ alum tube rail, ceiling translucent panels, alum threshold, floor (by others) | Included | Included | | | | |
| Metalworks Linear Faceted/Curved Ceiling system 8" panel per Note 9.03/G-006, see det 4/A-541 (no sheet A-541 provided) | Exclude/Qualify | Exclude/Qualify | | | | |
| Make Connection Between Fire Alarm Relay and Elevator Controller | Included | Included | | | | |
| Elevator Hostway Scaffolding | Included | Included | | | | |
| Hoisting | Included | Included | | | | |
| Textura invoice system | 360 | 360 | | | | |
| ARC.10 | (196,210) | 89,860 | | | | |
| TOTALS | 0 | 90,220 | 0 | 0 | 0 | 0 |
| Recommendation: | Amount | | | | | |
| Republic Elevator | 90,220 | | | | | |

Bid Evaluation Report

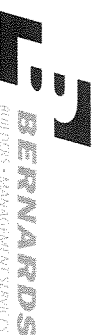

Fire Sprinklers

Marshall Classroom Building

Job Number 1641
 Bid Date 6/7/2017
 Date Printed 7/27/2017

Subcontractors

| Description | Subcontractors | | |
|--|----------------------|---------------------------|-------------------|
| | Apex Fire Protection | J.G. Tate Fire Protection | Superior Fire |
| Base Bid | 276,600 | 123,456 | 126,266 |
| Spec # : 21 1000 - Fire Protection | Included | Included | Included |
| License Designation C-16, Fire Protection Contractor | Included | Included | Included |
| Furnished, Installed, FOB Jobsite, Tax Included | Included | Included | Included |
| Plans and Specs Dated: 1/28/2016 & 10/4/2016 | Included | Included | Included |
| Acknowledgment of RFIs 1-75 dated 6.5.17 | Included | Included | Included |
| Bid Good for 60 Days | 60 Days | 30 Days | 30 days |
| Prevailing Wage | Included | Included | Included |
| Prequalified per Oxnard School District Standards | No | Yes | Yes |
| Attachment C Acknowledgement | Included | Included | Included |
| Furnish & Install Fire Sprinkler System | Included | Included | Included |
| Building 1, Classroom Building per FP sheets - FP-001 to 005 | Included | Included | Included |
| <i>Manufacturer - Tyco</i> | Included | Included | Included |
| Complete Wet Pipe Automatic Sprinkler System | Included | Included | Included |
| UL Approved Black Steel Piping, SCH 40 w/ Cast or Ductile Iron Screwed Fittings - 2" and Smaller | Included | Included | Included |
| UL Approved Black Steel Piping, SCH 40 w/ Rolled Grooved Ends, Grooved Fittings and Mechanical or Welded Outlets - 2.5" and Larger | Included | Included | Included |
| Complies with NFPA 13, 2013 ED., DSA, and Local AHJ Requirements | Included | Included | Included |
| POC from 6" AFF, 4x3 Flexible GRC | Included | Included | Included |
| 3" Fire Riser at Bldg - 1/FP-002 | Included | Included | Included |
| Connect 6" Underground Fire Department Connection | w/ Site Utilities | w/ Site Utilities | w/ Site Utilities |
| 4" Double Detector Check Valve Backflow Preventer (1/FP-02) | w/ Site Utilities | w/ Site Utilities | w/ Site Utilities |
| Standard Upright, Pendant, Sidewall Sprinklers | Included | Included | Included |
| Concealed Heads in Finished Ceilings w/ Cover Plate | Included | Included | Included |
| Flush Sidewall Head in Soffits | Included | Included | Included |
| Brass or White Finish | Included | Included | Included |
| All Underground Piping as Required | w/ Site Utilities | w/ Site Utilities | w/ Site Utilities |
| Piping Distribution (Risers, Mains & Branch Lines) | Included | Included | Included |
| Upright Sprinkler Deflectors as Shown | Included | Included | Included |
| Provide Head Guards as Required | Included | Included | Included |
| Head Box w/ Spare Heads and Wrenches | Included | Included | Included |
| Install Ceiling Tiles w/ Sprinkler Heads in Panels Where Required (FP-03) | Included | Included | Included |

Bid Evaluation Report



Fire Sprinklers

Marshall Classroom Building

Subcontractors

Job Number **1641**
 Bid Date **6/7/2017**
 Date Printed **7/27/2017**

| Description | Subcontractors | | | TOTALS | RECOMMENDATION |
|--|----------------------|---------------------------|-------------------|----------|----------------|
| | Apex Fire Protection | J.G. Tate Fire Protection | Superior Fire | | |
| Install sprinklers in elevator shaft and elevator equipment, not shown | 2,500 | 2,500 | 2,500 | | |
| All Seismic Bracing, Hangers, Embeds as Required | Included | Included | Included | | |
| Sleeves as Required | Included | Included | Included | | |
| Floor Blockouts, Coring, Saw Cutting as Required | Included | Included | Included | | |
| All Gauges, Valves, Flow and Tamper Switches | Included | Included | Included | | |
| Valve Seals, Tags, Safety Markers, and Charts | Included | Included | Included | | |
| Electric Bell | Included | Included | Included | | |
| Sound and Vibration Control | Included | 10,000 | Included | | |
| Furnish Access Panels as Required | Included | Included | 1,250 | | |
| Excavation and Backfill as Required | w/ Site Utilities | w/ Site Utilities | w/ Site Utilities | | |
| Fire Caulking / Sleeves / Firestopping | Included | Included | 1,250 | | |
| Permits / Plan Check / Inspections / Testing / Fees | 1,000 | 1,000 | 1,000 | | |
| Hydrostatic Testing at 200 PSI for (2) Hours | Included | Included | Included | | |
| Calculations / Engineered Plans / Shop Drawings | Included | Included | 2,500 | | |
| BIM Coordination | 5,000 | 5,000 | 5,000 | | |
| As-Builts and Record Documents | Included | Included | Included | | |
| Hoisting of Own Material as Required | Included | Included | Included | | |
| Schedule and Pay for State and Local Inspections | 1,500 | 1,500 | 1,500 | | |
| TOTALS | 286,600 | 143,456 | 151,266 | 0 | 0 |
| Recommendation: | Amount | | | | |
| J.G. Tate Fire Protection | 143,456 | | | | |

Bid Evaluation Report



Plumbing

Marshall Classroom Building

Subcontractors

| Description | City Commercial | HPS Mechanical | Moe | Precision Plumbing-Mechanical | Job Number | | |
|---|-----------------|----------------|----------|-------------------------------|------------------|--------------|-----------|
| | | | | | Suttles Plumbing | 1641 | |
| | | | | | | Bid Date | 6/7/2017 |
| | | | | | | Date Printed | 7/27/2017 |
| Base Bid | 315,100 | 349,530 | 335,765 | 416,610 | 412,000 | | |
| Spec #: 22 0500 - Basic Materials and Methods | Included | Included | Included | Included | Included | | |
| Spec #: 22 0553 - Identification | Included | Included | Included | Included | Included | | |
| Spec #: 22 0700 - Insulation | Included | Included | Included | Included | Included | | |
| Spec #: 22 0800 - Equipment and Systems Tests | Included | Included | Included | Included | Included | | |
| Spec #: 22 1100 - Domestic and Industrial Water Systems | Included | Included | Included | Included | Included | | |
| Spec #: 22 1300 - Drainage System | Included | Included | Included | Included | Included | | |
| Spec #: 22 4000 - Plumbing Fixtures | Included | Included | Included | Included | Included | | |
| Furnished, Installed, FOB Jobsite, Tax Included | Included | Included | Included | Included | Included | | |
| Plans and Specs Dated: 1/28/2016 & 10/4/2016 | Included | Included | Included | Included | Included | | |
| Acknowledgment of RFI's 1-75 dated 6.5.17 | Included | Included | Included | Included | Included | | |
| Bid Good for 60 Days | 30 Days | 30 Days | 60 Days | 60 Days | 90 Days | | |
| Prevailing Wage | Included | Included | Included | Included | Included | | |
| Prequalified per Oxnard School District Standards | Yes | Yes | No | Yes | Yes | | |
| Attachment C Acknowledgement | Included | Included | Included | Included | Included | | |
| Furnish & Install All Plumbing Fixtures w/ Associated Connections | Included | Included | Included | Included | Included | | |
| Plumbing Fixtures | Included | Included | Included | Included | Included | | |
| Water Closet, Floor-Mounted ADA (WC-1 & WC-2) | Included | Included | Included | Included | Included | | |
| Lavatory w/ Manual Metering Faucet, Wall-Mounted ADA (L-1 & L-2) | Included | Included | Included | Included | Included | | |
| Waterless Urinals (UR-1) | Included | Included | Included | Included | Included | | |
| Classroom Sink w/ Manual Metering Faucet (S-1) | Included | Included | Included | Included | Included | | |
| ADA Hilo Stainless Drinking Fountain (DF-1) | Included | Included | Included | Included | Included | | |
| Service Sinks (SS-1) | Included | Included | Included | Included | Included | | |
| Floor Drains (FD-1) | Included | Included | Included | Included | Included | | |
| Hose Bibbs (HB-1) | Included | Included | Included | Included | Included | | |
| Hose Bibbs on Landscape Drawings (RFI# 10) | 2,000 | 2,000 | 2,000 | 2,000 | 2,000 | | |
| Trap Primers (TP-1) | Included | Included | Included | Included | Included | | |
| Roof / Overflow Drains (RD-1 & OD-1) | Included | Included | Included | Included | Included | | |
| Cleanouts | Included | Included | Included | Included | Included | | |
| Gas Shut-Off Valves | Included | Included | Included | Included | Included | | |
| Water Hammer Arrestors | Included | Included | Included | Included | Included | | |
| All Fixtures Meet ADA | Included | Included | Included | Included | Included | | |
| Commercial Grade Toilet Seats | Included | Included | Included | Included | Included | | |
| Special Wrenches for Servicing | 250 | Included | Included | Included | Included | | |
| Faucet Repair Kits | 1,000 | Included | Included | 1,000 | Included | | |
| Furnish & Install All Plumbing Equipment w/ Associated Connections | Included | Included | Included | Included | Included | | |

Bid Evaluation Report



Plumbing

Marshall Classroom Building

Subcontractors

| Description | City Commerical | HPS Mechanical | Moe | Precision Plumbing-Mechanical | Job Number | |
|---|-----------------|----------------|----------|-------------------------------|------------------|-----------|
| | | | | | Suttles Plumbing | 1641 |
| | | | | | Bid Date | 6/7/2017 |
| | | | | | Date Printed | 7/27/2017 |
| <i>Manufacturers per P-001</i> | Included | Included | Included | Included | Included | |
| Tankless Gas Water Heaters (WH-1 & WH-2) | Included | Included | Included | Included | Included | |
| Circulating Pump (CP-1) | Included | Included | Included | Included | Included | |
| Expansion Tanks (ET-1) | Included | Included | Included | Included | Included | |
| Furnish & Install All Plumbing Piping | Included | Included | Included | Included | Included | |
| Hot and Cold Water Piping | Included | Included | Included | Included | Included | |
| Copper Type L Lead-Free Piping | Included | Included | Included | Included | Included | |
| <i>1. Price at all elevations</i> <i>Drugs, fittings, stops and white primed wire supply</i> | Included | Included | Included | Included | Included | |
| Waste and Vent Piping | Included | Included | Included | Included | Included | |
| Cast-Iron, No Hub | Included | Included | Included | Included | Included | |
| Storm and Roof Drain Piping | Included | Included | Included | Included | Included | |
| Cast-Iron, No Hub | Included | Included | Included | Included | Included | |
| Gas Piping | Included | Included | Included | Included | Included | |
| Schedule 40 Steel | Included | Included | Included | Included | Included | |
| Condensate Piping, HVAC | Included | Included | Included | Included | Included | |
| Copper Type M, Lead-Free | Included | Included | Included | Copper Type L | Included | |
| Connect Sewer, Storm Drain and Domestic Water | Included | Included | Included | Included | Included | |
| Service 5' Out | Included | Included | Included | Included | Included | |
| Piping Insulation as Required | Included | Included | Included | Included | Included | |
| Temporary Water for Construction Use (Meter by Others) | 13,400 | 13,400 | 13,400 | 13,400 | 13,400 | |
| Galvanize Flashings, Roof Jacks, Pipe Collars as Required | Included | Included | Included | Included | Included | |
| Sheet Metal Flashings for all Plumbing Penetrations | Included | Included | Included | Included | Included | |
| BIM Coordination | 10,000 | 17,500 | 10,000 | 10,000 | 10,000 | |
| Caulking and Sealants as Required | Included | Included | Included | Included | Included | |
| Fire Caulking, Sleeves, Fire Stopping as Required | Included | Included | Included | Included | Included | |
| Drilling, Boring, Cutting, Notching as Required | Included | Included | Included | Included | Included | |
| Earthquake Shut-Off Valves | Included | Included | Included | Included | Included | |
| Supports, Anchors, Seismic Bracing as Required | Included | Included | Included | Included | Included | |
| Safety walk and progressive cleanup | 4,642 | 4,642 | 4,642 | 4,642 | 4,642 | |
| Vibration Isolation | Included | Included | Included | Included | Included | |
| Access Panels as Required, Furnish Only | Included | Included | Included | Included | Included | |
| All Related Trenching and Backfill to 90% | Included | Included | Included | Included | Included | |
| Flush, Chlorinate, Disinfect and Sterilize Domestic Water | Included | Included | Included | Included | Included | |
| Haul Off Spoils Generated by Own Work | 2,470 | 10,000 | 2,925 | Included | 20,000 | |
| Provide and connect water line to construction trailer | 3,350 | 3,350 | 3,350 | 3,350 | 3,350 | |
| Temporary tool/storage bins | 1,400 | 1,400 | 1,400 | 1,400 | 1,400 | |
| Temporary Toilets | 2,100 | 2,100 | 2,100 | 2,100 | 2,100 | |

Bid Evaluation Report

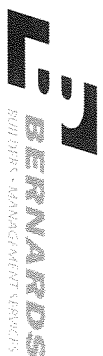

Plumbing

Marshall Classroom Building

Subcontractors

| Description | City Commerical | HPS Mechanical | Moe | Precision Plumbing-Mechanical | Suttles Plumbing | Job Number | 1641 |
|-------------------------------|-----------------|----------------|----------------|-------------------------------|------------------|----------------|-----------|
| | | | | | | Bid Date | 6/7/2017 |
| | | | | | | Date Printed | 7/27/2017 |
| Temporary Handwash facilities | 2,100 | 2,100 | 2,100 | 2,100 | 2,100 | | |
| ARC:27 | (2,500) | (2,500) | (2,500) | (2,500) | (2,500) | | |
| TOTALS | 355,312 | 403,522 | 375,182 | 454,102 | 473,850 | | 0 |
| Recommendation: | | | | | | Amount | |
| City Commerical | | | | | | 355,312 | |

Bid Evaluation Report

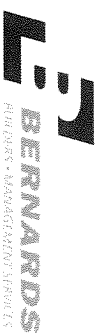

HVAC

Marshall Classroom Building

Subcontractors

Job Number **1641**
 Bid Date **6/7/2017**
 Date Printed **7/27/2017**

| Description | Climate Control | J.R. Barto | Sheldon Mechanical | WR Robbins Co. |
|---|-----------------|-----------------|--------------------|---------------------------------|
| Base Bid | 610,090 | 544,600 | 435,800 | 440,000 |
| Spec #: 23 0000 - General Provisions | Included | Included | Included | Included |
| Spec #: 23 0513 - Electric Motors and Controllers | Included | Included | Included | Included |
| Spec #: 23 0548 - Vibration Isolation and Seismic Restraints | Included | Included | Included | Included |
| Spec #: 23 2500 - Water Treatment | Quality Exclude | Quality Exclude | Quality Exclude | Quality Exclude |
| Spec #: 23 3100 - Air Transmission and Distribution System | Included | Included | Included | Included |
| Spec #: 23 8000 - Air Conditioning and Air Handling Management | Included | Included | Included | Included |
| Spec #: 23 9000 - Building Management System | Included | Included | Included | Included |
| Furnished, Installed, FOB Jobsite, Tax Included | Included | Included | Included | Included |
| Plans and Specs Dated: 1/28/2016 & 10/4/2016 | Included | Included | Included | Included |
| Acknowledgment of RFIs 1-75 dated 6.5.17 | Included | Included | Included | Included |
| Bid Good for 60 Days | 30 Days | 30 Days | 90 Days | 60 Days |
| Prevailing Wage | Included | Included | Included | Included |
| Prequalified per Oxnard School District Standards | No | Yes | Yes | Yes (Chapman Air Systems, Inc.) |
| Attachment C Acknowledgement | Included | Included | Included | Included |
| Furnish & Install All HVAC Equipment | | | | |
| Building Equipment | Included | Included | Included | Included |
| Roof-Mounted Package Units w/ Spring Isolators and Curb, AC1-AC12 - Carrier | Included | Included | Included | Included |
| Roof-Mounted, Exhaust Fans - Loren Cook | Included | Included | Included | Included |
| Ductless Split AC Units - Mitsubishi | Included | Included | Included | Included |
| Heating Ventilator Air Units - Reznor | Included | Included | Included | Included |
| Factory Curbs/ Install | Included | Included | Included | Included |
| Furnish & Install All Ductwork and Distribution | | | | |
| Sheet Metal Lined Round Ducts | Included | Included | Included | Included |
| Sheet Metal Rectangular Ducts | Included | Included | Included | Included |
| Flexible Round Ducts | Included | Included | Included | Included |
| Building Distribution | Included | Included | Included | Included |
| Supply, Return and Exhaust Ductwork | Included | Included | Included | Included |
| Ceiling Supply/Return/Exhaust Diffusers | Included | Included | Included | Included |
| Supply/Return/Exhaust Air Side Grilles | Included | Included | Included | Included |
| Side Wall Mounted Transfer Grilles | Included | Included | Included | Included |
| Outdoor Exhaust Grilles | Included | Included | Included | Included |
| Fire/Smoke Dampers | Included | Included | Included | Included |
| 90° Elbows at Ceiling Diffusers | Included | Included | Included | Included |
| Sound Boots as Required | Included | Included | Included | Included |
| Sheet Metal Louvers | Included | Included | 3,800 | Included |

Bid Evaluation Report



HVAC

Marshall Classroom Building

Subcontractors

Job Number **1641**
 Bid Date **6/7/2017**
 Date Printed **7/27/2017**

| Description | Climate Control | | | | Mechanical | | | |
|--|--------------------|--------------------|--------------------|--------------------|-----------------|-----------------|-----------------|--|
| | J.R. Barto | Sheldon | WR Robbins Co. | | J.R. Barto | Sheldon | WR Robbins Co. | |
| Backdraft Dampers at Exhaust as Required | Included | Included | Included | Included | Included | Included | Included | |
| Condensate Drain Piping - 1/1M505 | w/ Plumbing 10,050 | w/ Plumbing 10,050 | w/ Plumbing 10,050 | w/ Plumbing 20,000 | | | | |
| 22 ga galv hoods at roof ductwork per 4/M-510 | | | | | | | | |
| Furnish & Install HVAC Controls | Included | Included | Included | Included | Included | Included | Included | |
| Energy Management and Building Management Control Systems (DDC) | Included | Included | Included | Included | Included | Included | Included | |
| <i>MFR - Aleton</i> | Included | Included | Included | Included | Included | Included | Included | |
| Tie-In Controls w/ Current EMS Already Serving the Existing Campus (RFI #29) | Included | Included | Included | Included | Included | Included | Included | |
| All Low Voltage Wiring for Own Systems | Included | Included | Included | Included | Included | Included | Included | |
| All Duct Supports, Seismic Restraints, and Bracing as Required | Included | Included | Included | Included | Included | Included | Included | |
| HVAC Mounting - M.W. Sausse & Co, Vibrex VIC-EQ w/ Spring Mounts M-521 | Included | Included | Included | Included | Included | Included | Included | |
| All Piping and Duct Insulation as Required | Included | Included | Included | Included | Included | Included | Included | |
| All Mechanical Piping as Shown on Plans | Included | Included | Included | Included | Included | Included | Included | |
| Sound and Vibration Control | Included | Included | Included | Included | Included | Included | Included | |
| Access Panels as Required - Furnish Only | Included | 3,500 | Included | Included | Included | Included | Included | |
| All Required Signage and Identification Labels | Included | Included | Included | Included | Included | Included | Included | |
| Splay Wires for HVAC Registers and Grilles as Required | w/ ACT | w/ ACT | w/ ACT | w/ ACT | w/ ACT | w/ ACT | w/ ACT | |
| Safety walk and progressive cleanup | 6,218 | 6,218 | 6,218 | 6,218 | 6,218 | 6,218 | 6,218 | |
| Construction Filters and Final Filters | Included | Included | Included | Included | Included | Included | Included | |
| All Sheet Metal Flashings as Required | Included | Included | Included | Included | Included | Included | Included | |
| Firestopping at Penetrations | Included | 2,000 | Included | Included | Included | Included | Included | |
| Testing and Balancing | Included | Included | Included | Included | Included | Included | Included | |
| Duct Pressure Testing | Quality Exclude | Quality Exclude | Quality Exclude | Quality Exclude | Quality Exclude | Quality Exclude | Quality Exclude | |
| Hoisting of Own Material as Required | Included | Included | Included | Included | Included | Included | Included | |
| BIM Coordination | 6,700 | 6,700 | 6,700 | 6,700 | 6,700 | 6,700 | 6,700 | |
| ARC.11 | (56,000) | (56,000) | (56,500) | (56,000) | (56,000) | (56,000) | (56,000) | |
| ARC.24 | (42,000) | (42,000) | (42,600) | (42,000) | (42,000) | (42,000) | (42,000) | |
| TOTALS | 535,057 | 475,068 | 366,968 | 374,918 | 0 | 0 | 0 | |
| Recommendation: | Amount | | | | | | | |
| Sheldon Mechanical | 366,968 | | | | | | | |

Bid Evaluation Report



Electrical / Low Voltage

Marshall Classroom Building

Subcontractors

| Description | Oilfield Electric | Reyes & Sons | Taft Electric | Venco | Job Number | | |
|---|-------------------|--------------|---------------|-----------|------------|-----------------|-----------|
| | | | | | Siemens | 1641 | |
| | | | | | | Bid Date | 6/7/2017 |
| | | | | | | Date Printed | 7/27/2017 |
| Base Bid | 1,241,580 | 1,075,100 | 989,000 | 1,020,000 | | Fire Alarm Only | |
| Division 26 - Electrical | Included | Included | Included | Included | | | |
| Spec #: 26 0126 - Inspection Test and Acceptance | Included | Included | Included | Included | | | |
| Spec #: 26 0500 - Common Work Results for Electrical | Included | Included | Included | Included | | | |
| Spec #: 26 0513 - Basic Electrical Materials and Methods | Included | Included | Included | Included | | | |
| Spec #: 26 0519 - Low-Voltage Wires (600 Volt AC) | Included | Included | Included | Included | | | |
| Spec #: 26 0526 - Grounding and Bonding | Included | Included | Included | Included | | | |
| Spec #: 26 0533 - Raceways and Boxes Fitting and Supports | Included | Included | Included | Included | | | |
| Spec #: 26 0586 - Motors and Drives | Included | Included | Included | Included | | | |
| Spec #: 26 0800 - Electrical Systems & Commissioning | Included | Included | Included | Included | | | |
| Spec #: 26 0923 - Lighting Control Systems | Included | Included | Included | Included | | | |
| Spec #: 26 1000 - Service Entrance | Included | Included | Included | Included | | | |
| Spec #: 26 2200 - Low Voltage Transformers | Included | Included | Included | Included | | | |
| Spec #: 26 2413 - Switchboards 1000 | Included | Included | Included | Included | | | |
| Spec #: 26 2416 - Panelboards and Signal Terminal Cabinets | Included | Included | Included | Included | | | |
| Spec #: 26 2419 - Motor Control Devices | Included | Included | Included | Included | | | |
| Spec #: 26 5000 - Lighting | Included | Included | Included | Included | | | |
| Spec #: 26 5200 - Emergency Power Systems | Included | Included | Included | Included | | | |
| Spec #: 23 0513 - Electric Motors and Controllers | Included | Included | Included | Included | | | |
| Division 27 - Communications | Included | Included | Included | Included | | | |
| Spec #: 27 0126 - Test and Acceptance Requirements for Structured Cabling | Included | Included | Included | Included | | | |
| Spec #: 27 1013 - Structured Cabling | Included | Included | Included | Included | | | |
| Spec #: 27 4113 - Classroom Sound Enhancement System | Included | Included | Included | Included | | | |
| Spec #: 27 5116 - Public Address and Intercommunication Systems | Included | Included | Included | Included | | | |
| Spec #: 27 5313 - Clock and Program Systems | Included | Included | Included | Included | | | |
| Division 28 - Electronic Safety and Security | Included | Included | Included | Included | | | |
| Spec #: 28 1600 - Intrusion Detection System | Included | Included | Included | Included | | | |
| Spec #: 28 3100 - Fire Detection and Alarm System | Included | Included | Included | Included | | | |
| Furnished, Installed, FOB Jobsite, Tax Included | Included | Included | Included | Included | | | |
| Plans and Specs Dated: 1/28/2016 & 10/4/2016 | Included | Included | Included | Included | | | |
| Acknowledgment of RFIs 1-75 dated 6.5.17 | Included | Included | Included | Included | | | |
| Bid Good for 60 Days | 30 days | 60 Days | 60 Days | 30 Days | | | 60 Days |

Bid Evaluation Report

Electrical / Low Voltage

Marshall Classroom Building

Subcontractors

| Description | Oilfield Electric | | Reyes & Sons | | Taft Electric | | Venco | | Siemens | |
|---|-------------------|-----|--------------|-----|---------------------|-----|------------|-----|----------|----|
| | Included | Yes | Included | Yes | Included | Yes | Included | Yes | Included | No |
| Prequalified per Oxnard School District Standards | Included | Yes | Included | Yes | Included | Yes | Included | Yes | Included | No |
| Attachment C Acknowledgement | Included | | Included | | Included | | Included | | Included | |
| Furnish & Install Building Electrical | | | | | | | | | | |
| Main Gear and Panels | Included | | Included | | Included | | Included | | Included | |
| 1200A WP Main Switch Board, 480Y/277V, 3 Phase, 4W Panel board ("MP"/E-030) | Included | | Included | | Included | | Included | | Included | |
| 500KVA WP Site Transformer w/ Disconnect | Included | | Included | | Included | | Included | | Included | |
| Distribution Boards | Included | | Included | | Included | | Included | | Included | |
| Panel Boards | Included | | Included | | Included | | Included | | Included | |
| Lighting Control Panels and Lighting Control System | Included | | Included | | Included | | Included | | Included | |
| Circuit Breakers | Included | | Included | | Included | | Included | | Included | |
| Transformers | Included | | Included | | Included | | Included | | Included | |
| Ground Bus / Grounding Systems | Included | | Included | | Included | | Included | | Included | |
| Distribution, Conduit and Wiring | Included | | Included | | Included | | Included | | Included | |
| Copper Bussing and Wiring w/ Rigid Conduit | Included | | Included | | Included | | Included | | Included | |
| Feeders (RFI# 26) | Included | | Included | | Included | | Included | | Included | |
| Power Distribution | Included | | Included | | Included | | Included | | Included | |
| Conduits & Raceways | Included | | Included | | Included | | Included | | Included | |
| Lighting Switches, Conduit and Wiring | Included | | Included | | Included | | Included | | Included | |
| Cable Trays | Included | | Included | | None Shown | | None Shown | | Included | |
| Terminal Cabinets & Racks | Included | | Included | | Included | | Included | | Included | |
| Outlet & Junction Boxes, Pull Boxes | Included | | Included | | Included | | Included | | Included | |
| Wiring Devices | Included | | Included | | Included | | Included | | Included | |
| Switches / Disconnects | Included | | Included | | Included | | Included | | Included | |
| Overcurrent Protection | Included | | Included | | Included | | Included | | Included | |
| Connections to Existing Generator | 2,500 | | 2,500 | | 2,500 | | 2,500 | | 2,500 | |
| Power to Equipment | Included | | Included | | Included | | Included | | Included | |
| Power to Mechanical & Plumbing Equipment | Included | | Included | | Included | | Included | | Included | |
| Power to Misc. Equipment / Motors / Devices | Included | | Included | | Included | | Included | | Included | |
| Power to Electric Overhead Coiling Doors w/ Low Voltage Wiring (RFI# 62) | Included | | Included | | Included | | Included | | Included | |
| Power to Building Lighting w/ Controls and Panels | Included | | Included | | Included | | Included | | Included | |
| Power for Irrigation Controller (RFI#65) | Included | | Included | | Included | | Included | | Included | |
| Conduit & Back Boxes Only: | Included | | Included | | Included | | Included | | Included | |
| Voice / Data / CATV Systems | Included | | Included | | Included | | Included | | Included | |
| Computer Network Cabling System | Included | | Included | | Stubs to Ceiling | | Included | | Included | |
| Autonomous PA System | Included | | Included | | Included | | Included | | Included | |
| Occupancy / Motion Sensor System | Included | | Included | | Included | | Included | | Included | |
| Energy Management Systems / HVAC Controls | Included | | Included | | T-Stat Conduit Only | | Included | | Included | |

Bid Evaluation Report

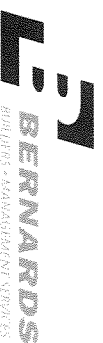

Electrical / Low Voltage

Marshall Classroom Building

Subcontractors

| Description | Subcontractors | | | | Siemens |
|---|-------------------|-----------------|-----------------|-----------------|-----------------|
| | Oilfield Electric | Reyes & Sons | Taft Electric | Venco | |
| Other Low Voltage Systems (E-001) | Included | Included | Included | Included | |
| Temporary Power and Lighting | 42,000 | 42,000 | 39,000 | 42,000 | |
| Install, Maintain, Relocate for Construction Offices | Included | Included | Included | Included | |
| Install, Maintain, Relocate for Building Areas & Site | Included | Included | Included | Included | |
| Temp Power for Elevator Testing and Build Out | Included | Included | Included | Included | |
| Temp Power Spider Boxes | Included | Included | Included | Included | |
| Temp Light Strings | Included | Included | Included | Included | |
| Conduit and Wire to Jobsite Trailers | Included | Included | Included | Included | |
| Furnish & Install Building Low Voltage Systems | | | | | |
| Fire Alarm System | See Below | See Below | See Below | See Below | See Below |
| Complete Addressable Fire Alarm System (E-204 & E-304) | 71,131 | 71,131 | Included | 71,131 | 71,131 |
| <i>Manufacturer - Siemens</i> | Siemens Bid | Siemens Bid | Included | Siemens Bid | Included |
| Per City Fire Dept. Standards | Included | Included | Included | Included | Included |
| FACP, Annunciator, Devices, Equipment & Conductors | Included | Included | Included | Included | Included |
| Fire Alarm Equipment Schedule E-020 | Included | Included | Included | Included | Included |
| Fire Alarm Details - E020-022 | Included | Included | Included | Included | Included |
| Elevator System | Connection Only | Connection Only | Connection Only | Connection Only | Connection Only |
| Horns, Strobes, Pull Stations, Detectors | Included | Included | Included | Included | Included |
| Smoke Duct Detectors - Furnish Only | Included | Included | Included | Included | Included |
| Interlock to HVAC Unit Shut-Down, as shown | Included | Included | Included | Included | Included |
| Complete Plans / Specifications / Calculations | Included | Included | Included | Included | Included |
| Submittals / Shop Drawings / As-Builts | Included | Included | Included | Included | Included |
| Permits / Licenses / Fees | Included | Included | Included | Included | Included |
| Security, Intrusion and Access Control System | 24,950 | Included | Included | 27,500 | |
| <i>MFR - Per Specs</i> | Included | Included | Included | Included | |
| Computer, Monitors, and Recording Devices | By Owner | By Owner | By Owner | By Owner | |
| Complete | Included | Included | Included | Included | |
| Infrared Motion Detectors | Included | Included | Included | Included | |
| Interconnection with Door and Gate Hardware as Required | Included | Included | Included | Included | |
| Interconnection with Overhead Doors as Required | Included | Included | Included | Included | |
| Interconnection with Elevators as Required | Included | Included | Included | Included | |
| All Weather-Rated Enclosures | Included | Included | Included | Included | |
| All Wiring as Required | Included | Included | Included | Included | |
| Complete Plans / Specifications / Calculations | Included | Included | Included | Included | |
| Submittals / Shop Drawings / As-Builts | Included | Included | Included | Included | |
| Permits / Licenses / Fees | Included | Included | Included | Included | |
| Telecom / Data / CATV (E-203 & E-303) | Included | Included | Included | Included | |
| Telecom / CATV Back-Bone Cabling | Included | Included | Included | Included | |

Bid Evaluation Report

Electrical / Low Voltage

Marshall Classroom Building

Subcontractors

| Description | Oilfield Electric | Reyes & Sons | Taft Electric | Venco | Job Number | 1641 |
|--|-------------------|--------------|---------------|----------|--------------|-----------|
| | | | | | Bid Date | 6/7/2017 |
| | | | | | Date Printed | 7/27/2017 |
| | | | | | Siemens | |
| Multi-Mode & Single-Mode Fiber Optic Cable | Included | Included | Included | Included | | |
| CAT 5E Cabling | Included | Included | Included | Included | | |
| Voice Cabling | Included | Included | Included | Included | | |
| Faceplates, Data and Phone Jacks | Included | Included | Included | Included | | |
| Signal Terminal Cabinets | Included | Included | Included | Included | | |
| All Connectors, Hangers, Labels as Required | Included | Included | Included | Included | | |
| All Wiring as Required | Included | Included | Included | Included | | |
| Install and Connect Owner Furnished Rack Mounted Uninterruptible Power Supplies and Ethernet Switches in Equipment Cabinets at Locations with Active Equipment. | Included | Included | Included | Included | | |
| Submittals / Shop Drawings / As-Builts | Included | Included | Included | Included | | |
| Permits / Licenses / Fees | Included | Included | Included | Included | | |
| Classroom Sound Enhancement System (E-203 & E-303) | Included | Included | Included | Included | | |
| <i>Manufacturer - Per Spec (274113, 2.01)</i> | Included | Included | Included | Included | | |
| Infrared Technology - Dome Sensors | Included | Included | Included | Included | | |
| Single and Multiple Input/Output Amplifiers | Included | Included | Included | Included | | |
| Loudspeakers w/ Integral Sealed Back Can | Included | Included | Included | Included | | |
| Wall Mounted Control Panel | Included | Included | Included | Included | | |
| Conductors and Cabling | Included | Included | Included | Included | | |
| Battery Chargers | Included | Included | Included | Included | | |
| Seal all Firewalls Penetrated | Included | Included | Included | Included | | |
| All Equipment Racks Bolted to the Floor | Included | Included | Included | Included | | |
| Submittals / Shop Drawings / As-Builts | Included | Included | Included | Included | | |
| Permits / Licenses / Fees | Included | Included | Included | Included | | |
| PA and Intercommunication System (E-203 & E-303) | Included | Included | Included | Included | | |
| <i>Manufacturer - Per Spec (275116, 2.01)</i> | Included | Included | Included | Included | | |
| System Equipment Racks | By Owner | By Owner | By Owner | By Owner | | |
| Central Card Cage / Shelf Assembly | By Owner | By Owner | By Owner | By Owner | | |
| Intercom System w/ Display Telephone | Included | Included | Included | Included | | |
| Wall Mounted Control Panel & Display Units | Included | Included | Included | Included | | |
| Turners, CD Players, Power Amplifiers, Loudspeakers Etc. | By Owner | By Owner | By Owner | By Owner | | |
| Terminal Blocks and Cabinets | Included | Included | Included | Included | | |
| Conductors and Cabling | Included | Included | Included | Included | | |
| Seal all Firewalls Penetrated | Included | Included | Included | Included | | |
| All Equipment Racks Bolted to the Floor | Included | Included | Included | Included | | |
| Submittals / Shop Drawings / As-Builts | Included | Included | Included | Included | | |
| Permits / Licenses / Fees | Included | Included | Included | Included | | |
| Master Clock System | Included | Included | Included | Included | | |
| <i>Manufacturer - Lathem LTR8-512-M or District Approved</i> | Included | Included | Included | Included | | |
| Power Supplies, Backboxes, Etc. | Included | Included | Included | Included | | |

Bid Evaluation Report

Electrical / Low Voltage

Marshall Classroom Building

Subcontractors

| Description | Oilfield Electric | Reyes & Sons | Taft Electric | Venco | Siemens | |
|--|-------------------|--------------|---------------|----------|--------------|-----------|
| | | | | | Job Number | 1641 |
| | | | | | Bid Date | 6/7/2017 |
| | | | | | Date Printed | 7/27/2017 |
| All Wall-Mounted Clocks | Included | Included | Included | Included | | |
| Standby Battery System (7 Days) | Included | Included | Included | Included | | |
| All Wiring as Required | Included | Included | Included | Included | | |
| Seal all Firewalls Penetrated | Included | Included | Included | Included | | |
| Furnish & Install Site Electrical | Included | Included | Included | Included | | |
| Safe-Off of Electrical For Removal of Existing Equipment, Conduit and Wiring (2/E-102) | Included | Included | Included | Included | | |
| Removal, Replacement at Existing Site Electrical (E-102) | 108,458 | 108,458 | 108,458 | 108,458 | 125,208 | 16,750 |
| Surveying route of new service | Included | Included | Included | Included | | |
| Potholing & line verification of new runs | Included | Included | Included | Included | | |
| Demo area at new transformer/switchgear in parking lot: | Included | Included | Included | Included | | |
| Demo curbs | Included | Included | Included | Included | | |
| Demo Landscape/AC Paving | Included | Included | Included | Included | | |
| AC Paving demo at dropoff | Included | Included | Included | Included | | |
| Sawcut and demo site concrete work entire run of Electrical runs | Included | Included | Included | Included | | |
| Add 50% more site concrete demo to go to a control or expansion joint | Included | Included | Included | Included | | |
| Sawcut and demo AC Paving work entire run of Electrical runs | Included | Included | Included | Included | | |
| Demo at Dirt / Landscape/Shrubs/Irrigation work entire run of Electrical runs | Included | Included | Included | Included | | |
| New work for SCE work (E-101 & E-102) | Included | Included | Included | Included | | |
| New Pads at new SCE transformer - 8'x10' - 1/E-102 | Included | Included | Included | Included | | |
| New Pads at new 500kva Transformer - 16'x21' - 1/E-102 | Included | Included | Included | Included | | |
| New Curbs (from Demo above) | Included | Included | Included | Included | | |
| Put-Back Balance of Landscape/AC Paving in reworked electrical area at existing parking lot | Included | Included | Included | Included | | |
| AC Paving at trench that crossed the Dropoff drive lane | Included | Included | Included | Included | | |
| Possible Re-Striping | Included | Included | Included | Included | | |
| Reinstall site concrete work entire run of Electrical runs - this appears to be colored concrete | Included | Included | Included | Included | | |
| Reinstall the Added 50% more site concrete demo to go to a control or expansion joint | Included | Included | Included | Included | | |
| Reinstall AC Paving work entire run of Electrical runs | Included | Included | Included | Included | | |
| Reinstall Dirt/Landscape/Shrub/Irrigation work entire run of Electrical runs | Included | Included | Included | Included | | |

Bid Evaluation Report



Electrical / Low Voltage

Marshall Classroom Building

Subcontractors

| Description | Oilfield Electric | Reyes & Sons | Taff Electric | Venco | Job Number | 1641 |
|---|-------------------|-----------------|-----------------|-----------------|--------------|-----------|
| | | | | | Bid Date | 6/7/2017 |
| | | | | | Date Printed | 7/27/2017 |
| | | | | | Siemens | |
| Furnish / Install concrete filled steel Bollards with footings | Included | Included | Included | Included | | |
| Dry Utilities - Power | Included | Included | Included | Included | | |
| Secondary Conduit From New On-Site Transformer to New WP Main Switchboard (Wire by SCE) (1/E-102) | Included | Included | Included | Included | | |
| MP-1 - (3) 3" Conduit w/ (3) 350KCM & (1) #2/0 in Each Conduit (RFI# 26) | Included | Included | Included | Included | | |
| MP-2 - (3) 3" Conduit w/ (4) 250KCM & (1) #2/0 in Each Conduit & (2) 4" Conduit for Future Power to New Pullbox to New Building (RFI# 26) | Included | Included | Included | Included | | |
| Power to Existing "MSB" From New 500KVA Transformer | Included | Included | Included | Included | | |
| MP-1A - (6) 3" Conduit w/ (4) 350KCM & (1) 250KCM in Each Conduit (RFI# 26) | Included | Included | Included | Included | | |
| New Intercept Underground Pullbox and Connection to Existing Power for "MSB" | Included | Included | Included | Included | | |
| (4) 350KCM & (1) 250KCM Wiring in Existing "MSB" Conduits | Included | Included | Included | Included | | |
| Stub Out (2) Different Lines of (2) 4" Conduit for Future Power from New Pullbox (E-101) | Included | Included | Included | Included | | |
| Utility Company Primary Switch | w/ SCE | w/ SCE | w/ SCE | w/ SCE | | |
| Utility Company Site Transformer | w/ SCE | w/ SCE | w/ SCE | w/ SCE | | |
| Conductors: by Utility Company | w/ SCE | w/ SCE | w/ SCE | w/ SCE | | |
| Dry Utilities - Low Voltage | Included | Included | Included | Included | | |
| (5) 2" Conduits for Low Voltage Systems (FA, SEC, Clock, PA, Tele and Data) From Existing Building to New Pullbox to New Building (E-101) | Included | Included | Included | Included | | |
| (4) 2" Conduits for Future Low Voltage Stubbed From Existing Building to New Pullbox (E-101) | Included | Included | Included | Included | | |
| Stub Out (2) Different Lines of (4) 2" Conduit for Future Low Voltage from New Pullbox (E-101) | Included | Included | Included | Included | | |
| Underground Power Distribution for Site Lighting and Site Power | Assume Existing | Assume Existing | Assume Existing | Assume Existing | | |
| Power to PIVs, Tamper Switches, Backflows | Included | Included | Included | Included | | |
| Electrical Vaults / Pull Boxes, as required | Included | Included | Included | Included | | |
| Traffic Rated Covers / Frames, as required | Included | Included | Included | Included | | |
| Furnish & Install Lighting | | | | | | |
| LED and Fluorescent Lighting as Shown | Included | Included | Included | Included | | |
| Lighting Fixtures per Schedule on E-010 | Included | Included | Included | Included | | |

Bid Evaluation Report



Electrical / Low Voltage

Marshall Classroom Building

Subcontractors

| Description | Oilfield Electric | Reyes & Sons | Taft Electric | Venco | Job Number | | |
|--|-------------------|------------------|------------------|------------------|------------|---------------|-----------|
| | | | | | Siemens | 1641 | |
| | | | | | | Bid Date | 6/7/2017 |
| | | | | | | Date Printed | 7/27/2017 |
| Lighting Fixtures at New Classroom Building (E-201 & E-301) | Included | Included | Included | Included | | | |
| Exit Signs | Included | Included | Included | Included | | | |
| LED Lamps | Included | Included | Included | Included | | | |
| Non-LED Lamps | Included | Included | Included | Included | | | |
| Occupancy Sensors | Included | Included | Included | Included | | | |
| Spare Parts as Required (Spec. 265000, 3.03) | Included | Included | Included | Included | | | |
| Coordination of Shipping and Installation of Fixtures | Included | Included | Included | Included | | | |
| BIM Coordination (1 per Week for 2 Months) | 18,425 | 18,425 | 16,750 | 18,425 | | 3,000 | |
| Plywood Backboards | w/ Rough Carp | w/ Rough Carp | w/ Rough Carp | w/ Rough Carp | | | |
| Mounting & Anchoring Details - E7.1 & 7.2 | Included | Included | Included | Included | | | |
| Concrete base at Electrical Equipment 5/E-050 | w/ Site Concrete | w/ Site Concrete | w/ Site Concrete | w/ Site Concrete | | | |
| Protective Bollards 2/E-050 | w/ Misc. Metals | w/ Misc. Metals | w/ Misc. Metals | w/ Misc. Metals | | | |
| NEMA Enclosures, where shown | Included | Included | Included | Included | | | |
| Flashings at Penetrations | Included | Included | Included | 2,000 | | | |
| Caulkings / Sealants | Included | Included | Included | Included | | | |
| Sleeves / Fire Caulking / Firestopping, as required | Included | Included | Included | Included | | | |
| Sound and Vibration control | Included | Included | Included | Included | | | |
| All Block Outs, Inserts, Coring, Notching, etc. | Included | Included | Included | Included | | | |
| Backfill Trenches / Bedding | Included | Included | Included | Included | | | |
| Safety walk and progressive cleanup | 7,772 | 7,772 | 7,772 | 7,772 | | | |
| All Required Signage and Identification Labels | Included | Included | Included | Included | | | |
| Seismic Bracing to Meet Code | Included | Included | Included | Included | | | |
| Access Panels as Required - Furnish Only | Included | 5,000 | 3,000 | 4,000 | | 1,500 | |
| Haul Off Spoils Generated by Own Work | Included | 15,000 | 15,000 | 15,000 | | | |
| Electrical Permits | Included | 3,000 | No cost | 3,000 | | | |
| Disconnect & reconnect existing PV panels during SCE switch-over | 5,000 | 5,000 | 5,000 | 5,000 | | | |
| Refuse signs not included on lighting fixture schedule | 1,000 | 1,000 | 1,000 | 1,000 | | | |
| ARC.25 | (10,000) | (10,000) | (10,000) | (10,000) | | | |
| TOTALS | 1,512,816 | 1,344,386 | 1,177,480 | 1,317,786 | | 75,631 | 0 |
| Recommendation: | Amount | | | | | | |
| Taft Electric | 1,177,480 | | | | | | |

Bid Evaluation Report

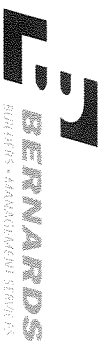

Electrical / Low Voltage

Marshall Classroom Building

Subcontractors

| Description | Oilfield Electric | Reyes & Sons | Taft Electric | Venco | Siemens | Job Number | 1641 |
|--|-------------------|--------------|---------------|-------|---------|--------------|-----------|
| | | | | | | Bid Date | 6/7/2017 |
| | | | | | | Date Printed | 7/27/2017 |
| Alternates | | | | | | | |
| Add Alternate (RFI#70) - Per Spec 101400 2.07B, Provide Refuse Sign not Indicated on Lighting Fixture Schedule. | | | \$850/ea | | | | |
| Add Alternate (RFI #16) - Connect Genset w/ Power Required for Essential Equipment to run During Potential Power Outages such as Site & Parking Lot Lights, Fire Alarm Panel, Security System, and Jobsite/Trailers Related Electrical Requirements. | | | 35,000 | | | | |

Bid Evaluation Report

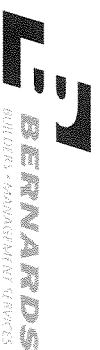

Demo & Earthwork

Marshall Classroom Building

Subcontractors

Job Number **1641**
 Bid Date **6/7/2017**
 Date Printed **7/27/2017**

| Description | Standard Demolition | Damar Const. | Leko Const. | Toro Ent. | | |
|---|---------------------|--------------|--------------|--------------|--------|--|
| Base Bid | See Below | See Below | See Below | See Below | | |
| Spec #: 31 1000 - Site Clearing | Included | Included | Included | Included | | |
| Spec #: 31 2200 - Grading | Included | Included | Included | Included | | |
| Spec #: 31 2316 - Excavation & Fill Paving | Included | Included | Included | Included | | |
| Spec #: 31 2319 - Excavation & Fill Structures | Included | Included | Included | Included | | |
| Spec #: 31 2323 - Excavation & Fill Utilities | Included | Included | Included | Included | | |
| Spec #: 31 2326 - Base Course | Included | Included | Included | Included | | |
| Soil Report: by CTE South dated 7/11/16 | Included | Included | Included | Included | | |
| Bond Rate (if required) | | | | | | |
| Furnished, Installed, FOB Jobsite, Tax Included | Included | Included | Included | Included | | |
| Plans and Specs Dated: 1/28/2016 & 10/4/2016 | Included | Included | Included | Included | | |
| Acknowledgment of RFI's 1-75 dated 6.5.17 | Included | Included | Included | Included | | |
| Bid Good for 60 Days | Included | Included | Included | Included | | |
| Prevailing Wage | Included | Included | Included | Included | | |
| Prequalified per Oxnard School District Standards | N/A | N/A | N/A | N/A | | |
| Attachment C Acknowledgement | N/A | N/A | N/A | N/A | | |
| Demolition | | | | | | |
| Demolition Plan C-101, at New Building location | 35,467 | 32,985 | 35,467 | 35,467 | No Bid | |
| Demolition Plan C-102, at Reworked Existing Parking Lot area | Included | Included | Included | Included | | |
| Demolition Plan C-103, at New Play Area location | Included | Included | Included | Included | | |
| Underground Utility Location, Potholing, Capping or Disconnecting Utilities | 5,000 | 5,000 | 5,000 | 5,000 | | |
| Removal Notes: | Included | Included | Included | Included | | |
| 1 - Remove existing asphalt pavement & base, full depth | Included | Included | Included | Included | | |
| 2 - Clear, grub & remove existing turf/planter/exposed subgrade area | Included | Included | Included | Included | | |
| 3 - Remove existing shrubs, trees and roots | Included | Included | Included | Included | | |
| 4 - Remove existing catch basin | Included | Included | Included | Included | | |
| 5 - Remove Play area, including the existing play structure (Per RFI#11) | Included | 1,500 | Included | Included | | |
| 6 - Sawcut existing & remove existing pavement, curb or v-gutter | Included | Included | Included | Included | | |
| 7 - Remove existing curb | Included | Included | Included | Included | | |
| 8 - Remove existing utilities (identified) | Included | Included | Included | Included | | |
| 9 - Sandblast existing striping | Included | Included | Included | Included | | |
| 10 - Contractor to rework existing irrigation as needed to allow for new const. Provide shop drawings for approval of revised/reworked irrigation system prior to re-installation | w/ Landscape | w/ Landscape | w/ Landscape | w/ Landscape | | |
| 11 - Remove existing concrete V-gutter | Included | Included | Included | Included | | |
| 12 - Remove sign in its entirety | Included | Included | Included | Included | | |
| 30-39 - Protect-In-Place items as noted | Included | Included | Included | Included | | |

Bid Evaluation Report



Demo & Earthwork

Marshall Classroom Building

Subcontractors

| Description | Standard Demolition | Damar Const. | Leko Const. | Toro Ent. | Job Number | 1641 |
|--|---------------------|--------------|---------------|---------------|--------------|-----------|
| | | | | | Bid Date | 6/7/2017 |
| | | | | | Date Printed | 7/27/2017 |
| Demo Mobilizations | 1,000 | Included | Includes 2 ea | Includes 2 ea | | |
| Add for demo of existing handball court walls & footings | Excluded | Excluded | Excluded | Excluded | | |
| Grading | No Bid | 94,720 | 108,940 | 96,507 | | |
| See General Civil Notes pertaining to your scope - C-001 | ----- | Included | Included | Included | | |
| Water Meter and Construction Watering for Own Scope | ----- | 1,000 | 1,000 | 1,000 | | |
| Erosion Control for your work (none shown on drawings) | ----- | 2,500 | 2,500 | 2,500 | | |
| Haul route for your work | ----- | Included | Included | Included | | |
| Move-Ins as required | ----- | Included | Included | Included | | |
| July '17 Move-On | ----- | Included | Included | Included | | |
| Include per Composite Grading Plan C-300,301,302 and Grading Sections C-303-304 | ----- | Included | Included | Included | | |
| Mass Excavation and Fine Grade Subgrade | ----- | Included | Included | Included | | |
| Soils Report: #5.2-Site Preparation, Geotechnical & Grading Notes: C-001 | ----- | Included | Included | Included | | |
| Temp Soil Stabilization (if required) | ----- | Included | Included | Included | | |
| Over-Ex to suitable native soils (varies across site, but generally lie approx 4' below current grades) or minimum 42" below bottom of all footings, whichever depth is greatest | ----- | Included | Included | Included | | |
| See Structural detail 15/S-400A, Typical Foundation & Slab Subgrade - excavation to 42" below footing and 60" below finish grade | ----- | Included | Included | Included | | |
| Extend 5' from Perimeter Edges | ----- | Included | Included | Included | | |
| Onsite existing fill disturbed for agricultural activities and native materials are suitable for use as fill and backfill materials | ----- | Included | Included | Included | | |
| Over-Ex at Elevator Pit | ----- | Included | Included | Included | | |
| Over-Ex 24" at Site Conditions - AC Paving, Site concrete, Unit Pavers, Play Area surfacing | ----- | Included | Included | Included | | |
| Sub-Grade Compaction of 90% | ----- | Included | Included | Included | | |
| At PCC Pavers: removal, excavation and recompaction of top 24" to 95% | ----- | Included | Included | Included | | |
| New Play Area: C-103, 9/C-702 | ----- | Included | Included | Included | | |
| Overexcavate & recompact area after demo, ready for perimeter concrete curb (by others) | ----- | Included | Included | Included | | |
| Include Type 2 sub-base to 95% compaction - thickness to be 4" | ----- | 5,000 | 5,000 | 5,000 | | |
| Geofabric over subbase, per cut sheet from RFI#12 response - provide Alternate Add | ----- | Not required | Not required | Not required | | |
| Excavation for mow strips | ----- | 2,500 | Included | Included | | |

Bid Evaluation Report



Demo & Earthwork

Marshall Classroom Building

Subcontractors

Job Number 1641
 Bid Date 6/7/2017
 Date Printed 7/27/2017

| Description | Standard Demolition | Subcontractors | | | | |
|-------------------------------------|---------------------|----------------|----------------|----------------|----------|----------|
| | | Damar Const. | Leko Const. | Toro Ent. | | |
| Fine Grading for Sitework | ----- | Included | Included | Included | | |
| Export Spoils Stockpiled by Others | ----- | \$XX / CY | \$XX / CY | \$XX / CY | | |
| Concrete Footing Spoils, Structural | ----- | 8,125 | 8,125 | 8,125 | | |
| Concrete Footing Spoils, Site | ----- | 1,250 | 1,250 | 1,250 | | |
| Site Utilities | ----- | 2,500 | 2,500 | 2,500 | | |
| Plumbing, Electrical | ----- | 2,500 | 2,500 | 2,500 | | |
| Dust Control during construction | | 16,884 | 16,884 | 16,884 | | |
| TOTALS | 0 | 176,464 | 189,166 | 176,733 | 0 | 0 |
| Recommendation: | Amount | | | | | |
| Damar Const. | 176,464 | | | | | |

Bid Evaluation Report



Asphalt Paving & Striping

Marshall Classroom Building

Subcontractors

| Description | ABC Resources | Onyx Paving | Toro Ent. | Excel Paving | Job Number | B&M Contractors |
|--|---------------|-------------|-----------|--------------|-------------------|-----------------|
| | | | | | | |
| | | | | | Berry Engineering | 7/27/2017 |
| | | | | | | |
| Base Bid | 0 | 35,440 | See below | 64,950 | 37,772 | 49,825 |
| Spec #: 31 2316 - Excavation & Fill Paving | ----- | Included | Included | Included | Included | Included |
| Spec #: 31 2326 - Base Course | ----- | Included | Included | Included | Included | Included |
| Spec #: 32 0117 - Pavement Repair | ----- | Included | Included | Included | Included | Included |
| Spec #: 32 1216 - Asphalt Paving | ----- | Included | Included | Included | Included | Included |
| Spec #: 32 1236 - Seal for Bituminous Surfacing | Included | Included | Included | Included | Included | Included |
| Bond Rate (if required) | | | | | | |
| Furnished, Installed, FOB Jobsite, Tax Included | Included | Included | Included | Included | Included | Included |
| Plans and Specs Dated: 1/28/2016 & 10/4/2016 | Included | Included | Included | Included | Included | Included |
| Acknowledgment of RFIs 1-75 dated 6.5.17 | Included | Included | Included | Included | Included | Included |
| Bid Good for 60 Days | Included | Included | Included | Included | Included | Included |
| Prevailing Wage | Included | Included | Included | Included | Included | Included |
| Prequalified per Oxnard School District Standards | N/A | N/A | N/A | N/A | N/A | N/A |
| Attachment C Acknowledgement | N/A | N/A | N/A | N/A | N/A | N/A |
| AC Paving | | | | | | |
| See Legend on C-002: | No Bid | Included | Included | Included | Included | Included |
| Eastside of New Building - 3" thk AC Surfacing over 7" thk crushed aggregate base (CAB), per 1/C-702 | ----- | Included | Included | Included | Included | Included |
| Fire Lane, 4" thk (2" Class C2 & 2" Class B) AC Surfacing over 9" thk crushed aggregate base (CAB), per 1/C-702 | ----- | Included | 15,538 | Included | Included | Included |
| Include the Pavement-to-pavement joint detail, 4/C-702 | ----- | Included | Included | Included | Included | Included |
| Existing Parking Lot Rework, C-202 | ----- | Included | Included | Included | Included | Included |
| Sawcut and removal of existing paving (C-102) | ----- | w/ Demo | w/ Demo | w/ Demo | w/ Demo | w/ Demo |
| Remove, reinstall base & recompact subgrade if unsuitable per 32.01.17.3.02.B | ----- | w/ Demo | w/ Demo | w/ Demo | w/ Demo | w/ Demo |
| 3" thk AC Surfacing over 7" thk crushed aggregate base (CAB), per 1/C-702 | ----- | Included | 27,966 | Included | Included | Included |
| Redwood Header at Grass | ----- | Included | Included | Included | Included | Included |
| Final 2 coat Seal over new paving per specs | ----- | 2,850 | Included | Included | Included | Included |
| Clean, Re-Seal, Re-Stripe existing Playground area, not shown | Excluded | Excluded | Excluded | Excluded | Excluded | Excluded |
| Striping & Signage | | | | | | |
| Existing Parking Lot - Striping Plan C-204 | 9,275 | No Bid | No Bid | No Bid | No Bid | No Bid |
| Sandblast existing striping at existing lot per Demo sheet C-102 | Included | 8,790 | 10,820 | 10,820 | 10,820 | 10,820 |
| Installation of new work at Existing Parking Lot: Standard Parking Spaces - 4" thk white lane per Caltrans Std Plan A20B, detail 27B | Included | Included | ----- | ----- | ----- | ----- |
| Stripe Crosshatch Areas | Included | Included | ----- | ----- | ----- | ----- |

Bid Evaluation Report



Asphalt Paving & Striping

Marshall Classroom Building

Subcontractors

| Description | ABC Resources | Onyx Paving | Toro Ent. | Excel Paving | Job Number | 1641 |
|--|---------------|---------------|---------------|---------------|-------------------|-----------------|
| | | | | | Date Printed | 6/7/2017 |
| | | | | | Berry Engineering | B&M Contractors |
| | | | | | 7/27/2017 | |
| Stripe Arrows | Included | Included | ----- | ----- | | |
| Fire Lane Curbs Red - none shown | Included | Included | ----- | ----- | | |
| Accessible Parking Spaces - see A-104 | Included | Included | ----- | ----- | | |
| Concrete Wheel Stops at Accessible parking - 32 13 | Included | Included | ----- | ----- | | |
| 13, 2.01, C.1-3 & 13/A-105 | | | | | | |
| Precast 6' length x 6" ht doveled into paving per detail | Included | Included | ----- | ----- | | |
| Signage - Accessible sign w/ Posts & footing - 1, 9/A-105 | Included | Included | ----- | ----- | | |
| Existing Fire Lane road in front of new Building - FLS Plan G-003 | Included | Included | ----- | ----- | | |
| Signage - Fire Access Entrance Signage w/ Post & footing - Sheet Note #5 | Included | Included | ----- | ----- | | |
| Signage - New Fire Lane Sign w/ Post & footing - Sheet A-101 & 2/A105 (same as above) | Included | Included | ----- | ----- | | |
| Striping - "Where curb occurs, Paint curb Red to designate Fire Lane" - G-003 | Included | Included | ----- | ----- | | |
| Striping - "Fire flush to adjacent surface, paint 'No Parking Fire Lane' w/ Red Lettering" - G-003 | Included | Included | ----- | ----- | | |
| Existing Hopscotch, Foursquare, Tetherball adjacent to site RE-Striping - Allowance | 1,000 | 1,000 | ----- | ----- | | |
| Existing Main Entry into School - A-101 | Included | Included | ----- | ----- | | |
| Signage - New "Tow Away" Sign w/ Post & footing - 7/A-105 | Included | 500 | ----- | ----- | | |
| TOTALS | 0 | 48,580 | 54,324 | 75,770 | 48,592 | 60,645 |
| Recommendation: | Amount | | | | | |
| Onyx Paving | 48,580 | | | | | |

Bid Evaluation Report

Site Concrete

Marshall Classroom Building

Subcontractors

| Description | B&M Contractors | Barcelo Concrete | Santa Clarita Concrete | Toro Ent. | Job Number | 1641 |
|--|-----------------|------------------|------------------------|-----------------|-------------------|-----------|
| | | | | | Bid Date | 6/7/2017 |
| | | | | | Date Printed | 7/27/2017 |
| | | | | | Berry Engineering | |
| Base Bid | 176,900 | 267,864 | 135,000 | See below | 145,960 | |
| Spec # : 31 2316 - Excavation & Fill Paving | Included | Included | Included | Included | Included | |
| Spec # : 31 2319 - Excavation & Fill Structures | Included | Included | Included | Included | Included | |
| Spec # : 31 2326 - Base Course | Included | Included | Included | Included | Included | |
| Spec # : 32 1313 - Site Concrete Work | Included | Included | Included | Included | Included | |
| Bond Rate (if required) | | Bond @ 1% | Bond @ 1% | Bond @ 1% | Bond @ 1% | |
| Furnished, Installed, FOB Jobsite, Tax Included | Included | Included | Included | Included | Included | |
| Plans and Specs Dated: 1/28/2016 & 10/4/2016 | Included | Included | Included | Included | Included | |
| Acknowledgment of RFIs 1-75 dated 6.5.17 | Included | Included | Included | Included | Included | |
| Bid Good for 60 Days | 30 Days | 90 days | 30 Days | 30 Days | 30 Days | |
| Prevailing Wage | Included | Included | Included | Included | Included | |
| Prequalified per Oxnard School District Standards | N/A | N/A | N/A | N/A | N/A | |
| Attachment C Acknowledgement | N/A | N/A | N/A | N/A | N/A | |
| On Site | | | | | | |
| Existing Parking Lot Rework, C-202 | Included | Included | Included | 12,522 | Included | |
| Sawcut and removal of existing site concrete (C-102) | w/ Demo | w/ Demo | w/ Demo | w/ Demo | w/ Demo | |
| Remove, reinstall base & recompact subgrade per Note 6, Det 3/C-703 | w/ Grading | w/ Grading | w/ Grading | w/ Grading | w/ Grading | |
| Note 12 - Concrete Curb per det 3/C-703 | Included | Included | Included | Included | Included | |
| 6" concrete curb w/ (2) #4 bars continuous length of curb | Included | Included | Included | Included | Included | |
| At New revised Accessible spaces, it is assume use of existing concrete handicap ramps at existing diagonal layout | Qualification | Qualification | Qualification | Qualification | Qualification | |
| Sandblasting (by demo), Re-Striping (by Striper) will be laid-out to reuse concrete ramps | by Others | by Others | by Others | by Others | by Others | |
| This subcontractor will install Truncated Domes at existing ramps per A-104 & det 5/A-105, 2 ea 3'x4' min | Excluded | Excluded | Excluded | Excluded | Excluded | |
| Truncated Domes to be Armor Tile or equal per detail 6/C-703 | Excluded | Excluded | Excluded | Excluded | Excluded | |
| Per SCE Drawings & E sheets: | | | | | | |
| Transformer Pad - 2/E-020 | Included | 10,400 | Included | 10,400 | 10,400 | |
| Install concrete-filled steel bollards 2/E-020 | Included | 2,000 | 2,000 | 2,000 | 2,000 | |
| New Rubber Surfacing at existing playground area adjacent to new building, C-203 | | | | | | |
| Note 13 - Concrete Curb per det 9/C-702 | Included | Included | Included | 22,332 | Included | |
| 6" wide concrete curb at perimeter of play area | Included | Included | Included | Included | Included | |
| Includes removal, excavation and recompaction of top 24" to 95% | w/Demo, Grading | w/Demo, Grading | w/Demo, Grading | w/Demo, Grading | w/Demo, Grading | |

Bid Evaluation Report



Site Concrete

Marshall Classroom Building

Subcontractors

| Description | Subcontractors | | | | Toro Ent. | Job Number 1641 | Bid Date 6/7/2017 | Date Printed 7/27/2017 | Berry Engineering |
|--|----------------------------|----------------------------|----------------------------|--|----------------------------|--------------------|----------------------|----------------------------|----------------------|
| | B&M Contractors | Barcelo Concrete | Santa Clarita Concrete | | | | | | |
| 4" Minimum Base course compacted & ready for rubber surfacing | 3,575 | 3,575 | 3,575 | | 3,575 | | | 3,575 | |
| New handball walls & footings complete adjacent new playground area, not shown | Excluded | Excluded | Excluded | | Excluded | | | Excluded | |
| Site Concrete Work at New Building: | Included | Included | Included | | 126,878 | | | Included | |
| 6" thk Concrete Pavement ove 4" crushed aggregate base (CAB), listed on legend C-002 & per 5/C-702(concrete pavement section detail) | Included | Included | Included | | Included | | | Included | |
| Rebar #4 @ 18" ocev | w/ Rebar Included | w/ Rebar Included | w/ Rebar Included | | w/ Rebar Included | | | w/ Rebar Included | |
| Site Control Plan C-201 | Included | Included | Included | | Included | | | Included | |
| Note 1 - 6" thk conc pavement over 4" CAB per 5/C-702 | Included | Included | Included | | Included | | | Included | |
| Note 2 - PCC Pavers & Sand Base per 1/C-703 | Included | 24,700 Included | 24,700 Included | | Included Angelus | | | Included Included | |
| Pavers MFR-None listed | Included | 2,130 | 2,130 | | Included | | | Included | |
| 24" wide concrete curb at perimeter of PCC Pavers | Included | 4,940 | 4,940 | | Included | | | Included | |
| 6" concrete Sub-Slab w/ #4@18"ocew under pavers | Included | | | | | | | | |
| Includes removal, excavation and recompaction of top 24" to 95% | w/Demo,Grading | w/Demo,Grading | w/Demo,Grading | | w/Demo,Grading | | | w/Demo,Grading | |
| Fine Grading prior to your work | Included | Included | Excluded | | Excluded | | | Excluded | |
| Note 3 - Planter area per Landscape drawings | w/ Landscape w/ Grading | w/ Landscape w/ Grading | w/ Landscape w/ Grading | | w/ Landscape w/ Grading | | | w/ Landscape w/ Grading | |
| Note 4 - Regrade & resurface the turf area | Included | Included | Included | | Included | | | Included | |
| Note 5 - 60" Mow Strip at Perimeter of New Building - 2/C-703 | Included | Included | Included | | Included | | | Included | |
| New mowstrip is 12" thk Including over 4" CAB compacted to 95% | Included | Included | Included | | Included | | | Included | |
| Note 6 - Seat Wall/CIP Benches per Architectural drawings, A-103 | Included | Included | Included | | 28,728 | | | Included | |
| L-Shaped 20' 4 each: Straight 10', 1 each Detail 10 & 11/A-105 - 1'6"wide x 1'-6" ht CIP Concrete w/ rebar | Included | Included | Included | | Included | | | Included | |
| Note 7 - Asphalt Pavement per 1/C-702 | w/ AC Paving | w/ AC Paving | w/ AC Paving | | w/ AC Paving | | | w/ AC Paving | |
| Note 8 - Concrete Pavement to Asphalt Pavement Transition 2/C-702 | Included | Included | Included | | Included | | | Included | |
| Note 9 - New Pavement to existing Pavement Joint - 4/C-702 | Included | Included | Included | | Included | | | Included | |
| Note 10 - AC Pavement thickness transition - 7/C-702 | w/ AC Paving | w/ AC Paving | w/ AC Paving | | w/ AC Paving | | | w/ AC Paving | |
| Note 11 - Stairs per Architectural drawings | w/ Steel & CIP | w/ Steel & CIP | w/ Steel & CIP | | w/ Steel & CIP | | | w/ Steel & CIP | |
| 6/A-105 - Typical CIP stair nosing - extruded aluminum contrasting strip nosing - NO CIP Stairs shown | w/ Steel & CIP | w/ Steel & CIP | w/ Steel & CIP | | w/ Steel & CIP | | | w/ Steel & CIP | |
| Note 12 - Concrete Curb 3/C-703 | Included | Included | Included | | Included | | | Included | |

Bid Evaluation Report



Site Concrete

Marshall Classroom Building

Subcontractors

| Description | Subcontractors | | | | Engineering |
|--|-------------------|------------------|------------------------|-----------------|-------------------|
| | B&M Contractors | Barcelo Concrete | Santa Clarita Concrete | Toro Ent. | |
| Note 13 - Rubber Mat Curb - 9/C-702 | Included | NEED | Included | Included | Berry Included |
| Note 14 - Gravity Wall - 7/C-703 | Included | Included | Included | Included | Included |
| Note 15 - Planter Wall per Architectural & Structural drawings - 2 shown on S-211 & 6/S401 | w/ CIP Concrete | Yes incl w/ site | w/ CIP Concrete | w/ CIP Concrete | w/ CIP Concrete |
| Note 15 - Planter Wall per Architectural & Structural drawings - 2 shown near stairs are NOT on S sheets, 36'x8' | w/ CIP Concrete | (30,000) | w/ CIP Concrete | Excluded | Excluded |
| 6/S-401 - 1'-0" thk wall, 1'-6" above grade | w/ CIP Concrete | Yes incl w/ site | w/ CIP Concrete | w/ CIP Concrete | w/ CIP Concrete |
| Note 16 - Not Used | ----- | ----- | ----- | ----- | ----- |
| Note 17 - Rubber Mat per Architectural drawings | w/ Play Equip | w/ Play Equip | w/ Play Equip | w/ Play Equip | w/ Play Equip |
| Base for all Site Concrete Paving | Included | Included | Included | Included | Included |
| Reinforcing Steel for All Work | Included | 12,025 | 12,025 | 12,025 | 12,025 |
| Control and Expansion Joints / Sealants | Included | Included | Included | Included | Included |
| Washout Bins | Included | 2,500 | 2,500 | Included | 2,500 |
| Mock-Ups | Included, if reqd | 6,000 | 6,000 | 5,575 | 6,000 |
| SIT.1 | (7,000) | (7,000) | (7,000) | (7,000) | (7,000) |
| SIT.2 | (15,000) | (15,000) | (15,000) | (15,000) | (15,000) |
| SIT.4 | (5,000) | (5,000) | (5,000) | (5,000) | (5,000) |
| SIT.7 | (6,000) | (6,000) | (6,000) | (6,000) | (6,000) |
| TOTALS | 147,475 | 281,534 | 159,870 | 191,035 | 149,460 |
| Recommendation: | Amount | | | | |
| B&M Contractors | 147,475 | | | | |

Bid Evaluation Report

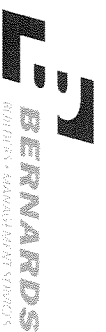

Playfield Equipment

Marshall Classroom Building

Subcontractors

| Description | Miracle Playground / Central Coast Playgrounds | Dave Bang Associates / Miracle Playground | SpectraTurf / Miracle Playground | Job Number | 1641 |
|---|---|--|--|--------------|-----------|
| | | | | Bid Date | 6/7/2017 |
| | | | | Date Printed | 7/27/2017 |
| Base Bid | See below | See below | See below | | |
| Spec #: 11 6800 - Playfield Equipment and Structures (Not Provided) | Included | Included | Included | | |
| Spec #: 02 88 00 - Playfield Equipment and Structures (RFI#11 Response) | Included | Included | Included | | |
| Bond Rate (if required) | N/A | Not provided | Bond at 1.5% | | |
| Furnished, Installed, FOB Jobsite, Tax Included | Included | Included | Included | | |
| Plans and Specs Dated: 1/28/2016 & 10/4/2016 | Included | Included | Included | | |
| Acknowledgment of RFI's 1-75 dated 6.5.17 | Included | Included | Included | | |
| Bid Good for 60 Days | 90 Days | 30 days | Included | | |
| Prevailing Wage | Included | Included | Included | | |
| Prequalified per Oxnard School District Standards | N/A | N/A | N/A | | |
| Attachment C Acknowledgement | N/A | N/A | N/A | | |
| Playfield Equipment & Structures - Miracle Playgrounds | 0 | 37,210 | 37,210 | | |
| Furnish Modular Units complete FOB Jobsite | Included | Included | Included | | |
| Unloading equipment at jobsite | Included | 600 | 600 | | |
| Custom Playground by Miracle Recreation Equipment | Included | Included | Included | | |
| Product spec & cut sheets in RFI#11 | Included | Included | Included | | |
| Separate price for Installation: | Included | Included | Included | | |
| Include excavation, layout installation of footings | Included | Included | Included | | |
| Sub provided by Miracle, Central Coast Playgrounds | Included | Included | Included | | |
| Excavate, haul spoils, place embed, install rebar(is this reqd?), place concrete, cleanup | Included | Included | Included | | |
| Footing X: 18" dia x 24" deep | 0 | 8,050 | 8,050 | | |
| Footing Y: 12" dia x 18" deep | 0 | 5,250 | 5,250 | | |
| Footing Z: 20" dia x 42" deep | 0 | 500 | 500 | | |
| Uncrate, separate, install all parts, dispose of empty boxes | 0 | 3,500 | 3,500 | | |
| Playfield Rubber Matting | | | | | |
| Furnish & install complete playground surface as MFR by PlayMax or equal | ----- | 45,416 | 42,471 | | |
| Demolition Plan C-103, at New Play Area location, remove existing AC Paving | ----- | w/ Demo | w/ Demo | | |
| Overexcavate & recompact area after demo | ----- | w/ Grading | w/ Grading | | |

Bid Evaluation Report

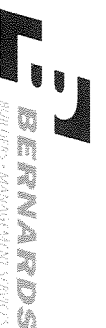

Playfield Equipment

Marshall Classroom Building

Subcontractors

Job Number: 1641
 Bid Date: 6/7/2017
 Date Printed: 7/27/2017

| Description | Miracle Playground Equipment / Central Coast Playgrounds | Dave Bang Associates / Miracle Playground | SpectraTurf / Miracle Playground | Amount | |
|--|--|---|----------------------------------|----------------|----------|
| | | | | 103,207 | 100,262 |
| Type 2 sub-base to 95% compaction - thickness to be 4" | | w/ Grading | Included | | |
| Geofabric over subbase | | 2,681 | 2,681 | | |
| Sheet C-203, Note 13 - Rubber Mat Curb - 9/C-702 around perimeter of rubber matting | | w/ Site Concrete | w/ Site Concrete | | |
| Rubber Matting subs work: | | Included | Included | | |
| MaxPour Cushion Layer - thickness to be xx? | | Included | Included | | |
| MaxPour/MaxPour-Supreme Top Layer - thickness to be xx? | | Included 4" | Included 4" | | |
| Per cut sheet two products are shown, MaxPour Supreme is not included in price | | Tot Turf | SpectraPour | | |
| Max fall height your bid is based upon | | Included 9' | Included 10' | | |
| Wear Layer to be 50% black/50% color w/ std aromatic resin | | Included | Included | | |
| See detail sheet, possible VE to install over aged asphalt paving | | Not recommended | N/A | | |
| Upgrade to Aliphatic (UV-stable, non-yellowing) Resin wear layer | | No bid | Add: \$4,934 | | |
| Drywell at Rubber Mat Curb at new Play Area Rubber Surfacing 9/C-702, drain shown on C-402 | | w/ Site Utilities | w/ Site Utilities | | |
| TOTALS | | 0 | 103,207 | 100,262 | 0 |
| Recommendation: | | Amount | | | |
| SpectraTurf / Miracle Playground | | 100,262 | | | |

Bid Evaluation Report

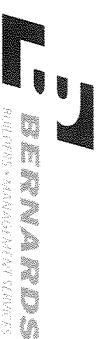

Landscape & Irrigation

Marshall Classroom Building

Subcontractors

| Description | Advanced Land. 2000 | | | | Job Number Bid Date | 1641 6/7/2017 |
|---|-----------------------|-----------------|---------------|---------------|------------------------|------------------|
| | Cascade Sprinklers | Durau Landscape | Hardy | Plowboy | | |
| Base Bid | 29,418 | 30,500 | 24,320 | 46,800 | 39,600 | 36,068 |
| Spec #: 323000, 328400, 329000, 329010 | Included | Included | Included | Included | Included | Included |
| Drawings: Planting & Irrigation Specs are also Listed on Sheet L-4 | Included | Included | Included | Included | Included | Included |
| Bond Rate (if required) | | | | | | |
| Furnished, Installed, FOB Jobsite, Tax Included | Included | Included | Included | Included | Included | Included |
| Plans and Specs Dated: 1/28/2016 & 10/4/2016 | Included | Included | Included | Included | Included | Included |
| Acknowledgment of RFIs 1-75 dated 6.5.17 | Included | Included | Included | Included | Included | Included |
| Bid Good for 60 Days | 30 Days | 30 Days | 30 Days | 90 days | Included | Included |
| Prevailing Wage | Included | Included | Included | Included | Included | Included |
| Prequalified per Oxnard School District Standards | N/A | N/A | N/A | N/A | N/A | N/A |
| Attachment C Acknowledgement | N/A | N/A | N/A | N/A | N/A | N/A |
| Landscaping & Irrigation: | | | | | | |
| Demolition Plan C-101, at New Building location | Included | Included | Included | Included | Included | Included |
| Removal Notes: | Included | Included | Included | Included | Included | Included |
| 10 - Contractor to rework existing irrigation as needed to allow for new const. Provide shop drawings for approval of revised/reworked irrigation system prior to re-installation | 2,500 | 2,500 | 2,500 | 2,500 | 2,500 | 2,500 |
| At New Building per Site Control Plan C-201 & L-1 | Included | Included | Included | Included | Included | Included |
| Note 3 - Planter area per Landscape drawings | Included | Included | Included | Included | Included | Included |
| Irrigation inside the CIP Planters - L-1 | Included | Included | Included | Included | Included | Included |
| Include tapping into existing mainline for new lines | 5,000 | 5,000 | 5,000 | 5,000 | 5,000 | 5,000 |
| Sawcut & remove AC paving & put back for access to mainline tap-in | 3,000 | 3,000 | 3,000 | 3,000 | 3,000 | 3,000 |
| New mainlines & lateral lines for irrigation & rigid pvc for control wire | Included | Included | Included | Included | Included | Included |
| Include sleeving as required | Included | Included | Included | Included | Included | Included |
| New Automatic Controller Assembly - Irritrol, 10/L-3 | Included | Included | Included | Included | Included | Included |
| Include Rain Shut-off Sensor | Included | Included | Included | Included | Included | Included |
| Include remote control valves & gate valves, 1 & 5/L-3 | Included | Included | Included | Included | Included | Included |
| Include quick couplers, 2/L-3 | Included | Included | Included | Included | Included | Included |
| Include pop-up shrub heads, 4/L-3 | Included | Included | Included | Included | Included | Included |
| Electrical to controller | w/ Electrical | w/ Electrical | w/ Electrical | w/ Electrical | w/ Electrical | w/ Electrical |
| Landscaping inside the CIP Planters - L-2 | Included | Included | Included | Included | Included | Included |
| Trees - 24" box, including Staking per 3/L-3 | Included | Included | Included | Included | Included | Included |
| Shrubs - 1 & 5 gallon | Included | Included | Included | Included | Included | Included |
| Vines - 15 gallon | Included | Included | Included | Included | Included | Included |
| Ground Cover | Included | Included | Included | Included | Included | Included |
| Safety walk and progressive cleanup | 4,640 | 4,640 | 4,640 | 4,640 | 4,640 | 4,640 |
| 90 Day Maintenance | Included | Included | Included | Included | Included | Included |

Bid Evaluation Report



Landscape & Irrigation

Marshall Classroom Building

Subcontractors

| Description | Subcontractors | | | | Job Number | Bid Date | Date Printed | Venco Western |
|---|---------------------|--------------------|-----------------|----------------|------------|----------|--------------|---------------|
| | Advanced Land. 2000 | Cascade Sprinklers | Dufau Landscape | Hardy | | | | |
| (1) Year Warranty | Included | Included | Included | Included | 1641 | 6/7/2017 | 7/27/2017 | Included |
| Spills Removal | 200 | 200 | 200 | 200 | | | | 200 |
| Move-Ins (2) | 1,500 | 1,500 | 1,500 | 1,500 | | | | 1,500 |
| Existing Parking Lot Rework, C-202 | 5,000 | 5,000 | 5,000 | 5,000 | | | | 5,000 |
| Removal & reinstallation of Irrigation at Demoeed areas | Included | Included | Included | Included | | | | Included |
| Removal & reinstallation of Planting at Demoeed areas | Included | Included | Included | Included | | | | Included |
| Existing Grass Field | 35,185 | 35,185 | 35,185 | 35,185 | | | | 35,185 |
| Modify existing Irrigation at grass playground for trailer/laydown area | Included | Included | Included | Included | | | | Included |
| Geofabric over the grass, rock surface as base during operations | Included | Included | Included | Included | | | | Included |
| Removal of rock & geofabric at project completion | Included | Included | Included | Included | | | | Included |
| Regrade, fine grade ready for new grass at laydown area | Included | Included | Included | Included | | | | Included |
| Rework & start-up existing Irrigation heads | Included | Included | Included | Included | | | | Included |
| Reinstallation of Grass Planting, hydroseed, at laydown area | Included | Included | Included | Included | | | | Included |
| TOTALS | 86,443 | 87,525 | 81,345 | 103,825 | | | | 96,625 |
| Recommendation: | Amount | | | | | | | |
| Dufau Landscape | 81,345 | | | | | | | |

Bid Evaluation Report

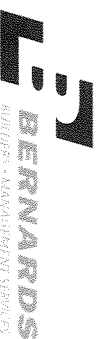

Site Utilities

Marshall Classroom Building

| Description | Subcontractors | | | | Suttles Plumbing | Toro Ent. |
|---|------------------|---------------------|----------------|-----------------|------------------|-----------|
| | BSN Construction | J. Vega Engineering | HPS Mechanical | Sam Hill & Sons | | |
| Base Bid | 217,229 | See below | 200,390 | See below | 245,000 | |
| Spec #: 31 2319 - Excavation & Fill Structures | Included | Included | Included | Included | Included | |
| Spec #: 31 2323 - Excavation & Fill Utilities | Included | Included | Included | Included | Included | |
| Spec #: 31 2326 - Base Course | Included | Included | Included | Included | Included | |
| Spec #: 33 1100 - Site Water Distribution Utilities | Included | Included | Included | Included | Included | |
| Spec #: 33 3000 - Site Sanitary Sewer Utilities | Included | Included | Included | Included | Included | |
| Spec #: 33 4000 - Storm Drainage Utilities | Included | Included | Included | Included | Included | |
| Bond Rate (if required) | Not listed | Not listed | Not listed | Not listed | Bond @1.44% | |
| Furnished, Installed, FOB Jobsite, Tax Included | Included | Included | Included | Included | Included | |
| Plans and Specs Dated: 1/28/2016 & 10/4/2016 | Included | Included | Included | Included | Included | |
| Acknowledgment of RFIs 1-75 dated 6.5.17 | Included | Included | Included | Included | Included | |
| Bid Good for 60 Days | 30 days | 30 days | 30 days | 30 days | 30 days | |
| Prequalified per Oxnard School District Standards | Included | Included | Included | Included | Included | |
| Attachment C Acknowledgement | N/A | N/A | N/A | N/A | N/A | |
| Site Utilities | | | | | | |
| Utility Location (C Below) | Included | Included | Included | Included | Included | |
| Cutting and Capping of Existing Utilities | 2,500 | 2,500 | 2,500 | 2,500 | 2,500 | |
| Layout and Trenching | Included | Included | Included | Included | Included | |
| Sawcutting & removal of surface for New Utilities | Included | Included | Included | Included | Included | |
| Traffic Control | 3,584 | 3,584 | 3,584 | 3,584 | 3,584 | |
| Temp Asphalt Patching | Included | Included | Included | Included | Included | |
| Excavation Spoils Stockpile | 2,048 | 2,048 | 2,048 | 2,048 | 2,048 | |
| Pressure Test and Flush System | Included | Included | Included | Included | Included | |
| Sewer | | | | | | |
| Site Utility Plan C-401,402,403,404 | Included | Included | Included | Included | Included | |
| Note 20 - Install SDR-353 Sanitary Sewer line per 4/C-701 | Included | Included | Included | Included | Included | |
| Note 21 - Connect to bldg sanitary sewer | Included | Included | Included | Included | Included | |
| Note 22 - Connect to existing onsite main line | Included | Included | Included | Included | Included | |
| Note 23 - Install Clean-out per 7/C-701 | Included | Included | Included | Included | Included | |
| Note 24 - Connect to onsite main line per 2/C-701 | Included | Included | Included | Included | Included | |
| Note 25 - House connection per APWA Std Plan 222-2 | Included | Included | Included | Included | Included | |
| Storm Drain | | | | | | |
| Site Utility Plan C-401,402,403,404 | Included | 173,320 | Included | 143,618 | Included | |
| Note 1 - Install SDR-35 storm drain line per 4/C-701 | Included | Included | Included | Included | Included | |
| Note 2 - Construct 12"x12" catch basin per 6/C-701 | Included | Included | Included | Included | Included | |
| Note 3 - Connect to existing onsite main line per 2/C-701 | Included | Included | Included | Included | Included | |

Bid Evaluation Report



Site Utilities

Marshall Classroom Building

Subcontractors

| Description | Subcontractors | | | | | Job Number | 1641 |
|--|------------------|---------------------|----------------|-----------------|------------------|--------------|-----------|
| | BSN Construction | J. Vega Engineering | HPS Mechanical | Sam Hill & Sons | Suttles Plumbing | Bid Date | 6/7/2017 |
| | | | | | | Date Printed | 7/27/2017 |
| | | | | | | Toro Ent. | |
| Note 4 - Install Clean-out per 7/C-701 | Included | Included | Included | Included | Included | | |
| Note 5 - Install Arturn grate NDS 1280 & catch basin 1200 or equal | Included | Included | Included | Included | Included | | |
| Note 6 - Connect to on-site main line per 2/C-702 | Included | Included | Included | Included | Included | | |
| Note 7 - Connect to bldg storm drain line | Included | Included | Included | Included | Included | | |
| Note 8 - Install SDR-21 storm drain line per 4/C-701 | Included | Included | Included | Included | Included | | |
| Note 9 - Install French Drain per 2/C-704 | Included | Included | Included | Included | Included | | |
| Other: Trench Drain concrete basin per 4/S-400A | Included | Included | Included | Included | Included | | |
| Drywell at Rubber Mat Curb at new Play Area Rubber Surfacing 9/C-702, drain shown on C-402 | Included | Included | Included | Included | Included | | |
| Water | | | | | | | |
| Site Utility Plan C-401,402,403,404 | Included | 64,295 | Included | Included | 33,353 | Included | |
| Note 30 - Connect to existing onsite main line | Included | Included | Included | Included | Included | Included | |
| Note 31 - Install 4" Double Check Detector Backflow Preventer Assembly with Fire Department Connection per 3/C-701, Ames 3000 SS OS&Y w/ Tamper Switches connected to Fire Alarm | Included | Included | Included | Included | Included | Included | |
| Note 32 - Install AWWA C900 PVC pressure Class 200 Water line per 4/C-701 | Included | Included | Included | Included | Included | Included | |
| Note 33 - Install concrete thrust block per 4/C-703 | Included | Included | Included | Included | Included | Included | |
| Note 34 - Connect to bldg Fire Water connection | Included | Included | Included | Included | Included | Included | |
| Note 35 - Connect to building Domestic Water connection | Included | Included | Included | Included | Included | Included | |
| Note 36 - Connect to existing onsite main line | Included | Included | Included | Included | Included | Included | |
| Note 37 - Install Gate valve per 5/C-701 | Included | Included | Included | Included | Included | Included | |
| Note 38 - Fire Department Connection per 1/C-704 | Included | Included | Included | Included | Included | Included | |
| Note 39 - Connect to onsite main water line | Included | Included | Included | Included | Included | Included | |
| Includes: | Included | Included | Included | Included | Included | Included | |
| Sawcutting for New Utilities | Included | Included | Included | Included | Included | Included | |
| Excavation, compact bottom, sand shading, install pipe, backfill, compaction of trench | Included | Included | Included | Included | Included | Included | |
| Base Pave Trenches | Included | Included | Included | Included | Included | Included | |
| Overlay trench with new AC Paving section | Included | Included | Included | Included | Included | Included | |
| Lane Closure/Traffic Control | Included | Included | Included | Included | Included | Included | |
| Water Line for Irrigation inside the CIP Planters - L-1 (not clearly indicated on C sheets) | 2,500 | 2,500 | 2,500 | 2,500 | 2,500 | 2,500 | |
| Include tapping into existing mainline for new lines | Included | Included | Included | Included | Included | Included | |
| Sawcut & remove AC paving & put back for access to mainline tap-in | Included | Included | Included | Included | Included | Included | |

Bid Evaluation Report



Site Utilities

Marshall Classroom Building

Subcontractors

| Description | Subcontractors | | | | Suttles Plumbing | Toro Ent. |
|---|------------------|---------------------|----------------|-----------------|------------------|-----------|
| | BSN Construction | J. Vega Engineering | HPS Mechanical | Sam Hill & Sons | | |
| New mainlines & lateral lines for irrigation & rigid pvc for control wire | Included | Included | Included | Included | Included | |
| Other: | | | | | | |
| FDC Bollards & Footings (include if not shown) | 1,000 | 1,000 | 1,000 | 1,000 | 1,000 | |
| POC Flanged into FS min 24" aff room by this sub - 1/FP-02 | Included | Included | Included | Included | Included | |
| Gas | | | | | | |
| NOT SHOWN on Site Utility Plan C-401,402,403,404 | Included | Included | Included | Included | Included | |
| Gas Lines per Plumbing Sheets | Included | Included | Included | Included | Included | |
| Connect to existing Gas Line onsite - Not Shown | See Allowance | See Allowance | See Allowance | See Allowance | See Allowance | |
| TOTALS | 228,861 | 325,112 | 212,022 | 210,055 | 256,632 | 0 |
| Recommendation: | Amount | | | | | |
| Sam Hill & Sons | 210,055 | | | | | |

OSD BOARD AGENDA ITEM

Name of Contributor: **Dr. Jesus Vaca**

Date of Meeting: **May 2, 2018**

- A. Preliminary _____
Study Session _____
Report _____
- B. Hearing: _____
- C. Consent Agenda _____
Agreement Category:
_____ Academic
_____ Enrichment
_____ Special Education
_____ Support Services
_____ Personnel
_____ Legal
_____ Facilities
- D. Action Items _____
- E. Approval of Minutes _____
- F. Board Policies 1st Reading X 2nd Reading _____

SEXUAL HARASSMENT – BP and AR 5145.7: Revision (Vaca)

The policy and regulation have been updated to reflect new laws, as recommended by the California School Boards Association (CSBA).

FISCAL IMPACT:

None

RECOMMENDATION:

It is the recommendation of the Assistant Superintendent, Human Resources that the Board of Trustees review the revised policy and regulation, as presented.

ADDITIONAL MATERIAL(S):

- BP 5145.7 Sexual Harassment (five pages)
- AR 5145.7 Sexual Harassment (eight pages)

SEXUAL HARASSMENT

The ~~Board of Trustees~~ *Governing Board* is committed to maintaining ~~an educational~~ *a safe school* environment that is free from harassment and discrimination. The Board prohibits, *at school or at school-sponsored or school-related activities*, sexual harassment ~~of students by other students, employees, or other persons, at school or at school-sponsored or school-related activities.~~ *targeted at any student by anyone.* The Board also prohibits retaliatory behavior or action against ~~persons who complain, testify, assist, or otherwise participate in district complaint processes.~~ *any person who reports, files a complaint or testifies about, or otherwise supports a complainant in alleging sexual harassment.*

The district strongly encourages any student who feels that he/she is being or has been sexually harassed on school grounds or at a school-sponsored or school-related activity by another student or an adult who has experienced off-campus sexual harassment that has a continuing effect on campus to immediately contact his/her teacher, the principal, or any other available school employee. Any employee who receives a report or observes an incident of sexual harassment shall notify the principal or a district compliance officer. Once notified, the principal or compliance officer shall take the steps to investigate and address the allegation, as specified in the accompanying administrative regulation.

(cf. 0410 - Nondiscrimination in District Programs and Activities)

(cf. 1312.1 - Complaints Concerning District Employees)

(cf. ~~1312.3 - Uniform Complaint Procedures~~)

(cf. ~~4119.11/4219.11/4319.11 - Sexual Harassment~~)

(cf. 5131 - Conduct)

(cf. 5131.2 - Bullying)

(cf. 5137 - Positive School Climate)

(cf. 5141.4 - Child Abuse Prevention and Reporting)

(cf. 5145.3 - Nondiscrimination/Harassment)

(cf. 6142.1 - Sexual Health and HIV/AIDS Prevention Instruction)

The Superintendent or designee shall take appropriate actions to reinforce the district's sexual harassment policy.

Instruction/Information

The Superintendent or designee shall ensure that all district students receive age-appropriate ~~instruction and~~ information on sexual harassment. Such instruction and information shall include:

1. What acts and behavior constitute sexual harassment, including the fact that sexual harassment could occur between people of the same sex *and could involve sexual violence*
2. A clear message that students do not have to endure sexual harassment *under any circumstance*

SEXUAL HARASSMENT (continued)

3. Encouragement to report observed instances of sexual harassment, even where the *alleged* victim of the harassment has not complained
4. *A clear message that student safety is the district's primary concern, and that any separate rule violation involving an alleged victim or any other person reporting a sexual harassment incident will be addressed separately and will not affect the manner in which the sexual harassment complaint will be received, investigated, or resolved*
5. *A clear message that, regardless of a complainant's noncompliance with the writing, timeline, or other formal filing requirements, every sexual harassment allegation that involves a student, whether as the complainant, respondent, or victim of the harassment, shall be investigated and prompt action shall be taken to stop any harassment, prevent recurrence, and address any continuing effect on students*
- 4.6. Information about the district's procedure for investigating complaints and the person(s) to whom a report of sexual harassment should be made
7. *Information about the rights of students and parents/guardians to file a civil or criminal complaint, as applicable, including the right to file a civil or criminal complaint while the district investigation of a sexual harassment complaint continues*
8. *A clear message that, when needed, the district will take interim measures to ensure a safe school environment for a student who is the complainant or victim of sexual harassment and/or other students during an investigation and that, to the extent possible, when such interim measures are taken, they shall not disadvantage the complainant or victim of the alleged harassment*

(cf. 5131.5—Vandalism and Graffiti)

(cf. 5137—Positive School Climate)

(cf. 5145.3—Nondiscrimination/Harassment)

(cf. 6142.1—Sexual Health and HIV/AIDS Prevention Instruction)

Complaint Process and Disciplinary Actions

~~Any student who feels that he/she is being or has been sexually harassed by a school employee, another student, or a non-employee on school grounds or at a school-related activity (e.g., a visiting athlete or coach) shall immediately contact his/her teacher or any other employee. An employee who receives such a complaint shall report it in accordance with administrative regulation.~~

(cf. 1312.1—Complaints Concerning District Employees)

(cf. 5141.4—Child Abuse Prevention and Reporting)

SEXUAL HARASSMENT (continued)

~~The Superintendent or designee shall ensure that any complaints regarding sexual harassment are immediately investigated in accordance with administrative regulation. When the Superintendent or designee has determined that harassment has occurred, he/she shall take prompt, appropriate action to end the harassment and to address its effects on the victim.~~

Sexual harassment complaints by and against students shall be investigated and resolved in accordance with law and district procedures specified in AR 1312.3 - Uniform Complaint Procedures. Principals are responsible for notifying students and parents/guardians that complaints of sexual harassment can be filed under AR 1312.3 and where to obtain a copy of the procedures.

(cf. 1312.3 - Uniform Complaint Procedures)

Upon investigation of a sexual harassment complaint, any student found to have engaged in sexual harassment or sexual violence in violation of this policy shall be subject to disciplinary action. For students in grades 4-12, disciplinary action may include suspension and/or expulsion, provided that, in imposing such discipline, the entire circumstances of the incident(s) shall be taken into account.

(cf. 5144 - Discipline)

(cf. 5144.1 - Suspension and Expulsion/Due Process)

(cf. 5144.2 - Suspension and Expulsion/Due Process (Students with Disabilities))

Upon investigation of a sexual harassment complaint, any employee found to have engaged in sexual harassment or sexual violence toward any student shall have his/her employment terminated in accordance with law and the applicable collective bargaining agreement.

(cf. 4117.7 - Employment Status Report)

(cf. 4118 - Dismissal/Suspension/Disciplinary Action)

(cf. 4218 - Dismissal/Suspension/Disciplinary Action)

(cf. 4119.11/4219.11/4319.11 - Sexual Harassment)

Disciplinary Actions

~~Any student who engages in sexual harassment of anyone at school or at a school sponsored or school related activity is in violation of this policy and shall be subject to disciplinary action. For students in grades 4-12, disciplinary action may include suspension and/or expulsion, provided that, in imposing such discipline, the entire circumstances of the incident(s) shall be taken into account.~~

~~*(cf. 5131 - Conduct)*~~

~~*(cf. 5144.1 - Suspension and Expulsion/Due Process)*~~

~~*(cf. 5144.2 - Suspension and Expulsion/Due Process (Students with Disabilities))*~~

Confidentiality and Record-Keeping

SEXUAL HARASSMENT (continued)

All complaints and allegations of sexual harassment shall be kept confidential except as necessary to carry out the investigation or take other subsequent necessary action. (~~5 CCR 4964~~)

(~~cf. 4119.23/4219.23/4319.23—Unauthorized Release of Confidential/Privileged Information~~)
(~~cf. 5125—Student Records~~)

The Superintendent or designee shall maintain a record of all reported cases of sexual harassment to enable the district to monitor, address, and prevent repetitive harassing behavior in ~~the~~ district schools.

(cf. 3580 - District Records)

Legal Reference:

EDUCATION CODE

200-262.4 Prohibition of discrimination on the basis of sex

48900 Grounds for suspension or expulsion

48900.2 Additional grounds for suspension or expulsion; sexual harassment

48904 Liability of parent/guardian for willful student misconduct

48980 Notice at beginning of term

CIVIL CODE

51.9 Liability for sexual harassment; business, service and professional relationships

1714.1 Liability of parents/guardians for willful misconduct of minor

GOVERNMENT CODE

12950.1 Sexual harassment training

CODE OF REGULATIONS, TITLE 5

4600-4687 Uniform ~~Complaint Procedures~~ complaint procedures

4900-4965 Nondiscrimination in elementary and secondary education programs

UNITED STATES CODE, TITLE 20

1221 Application of laws

1232g Family Educational Rights and Privacy Act

1681-1688 Title IX, discrimination

UNITED STATES CODE, TITLE 42

1983 Civil action for deprivation of rights

2000d-2000d-7 Title VI, Civil Rights Act of 1964

2000e-2000e-17 Title VII, Civil Rights Act of 1964 as amended

CODE OF FEDERAL REGULATIONS, TITLE 34

99.1-99.67 Family Educational Rights and Privacy

106.1-106.71 Nondiscrimination on the basis of sex in education programs

COURT DECISIONS

Donovan v. Poway Unified School District, (2008) 167 Cal.App.4th 567

Flores v. Morgan Hill Unified School District, (2003, 9th Cir.) 324 F.3d 1130

Reese v. Jefferson School District, (2001, 9th Cir.) 208 F.3d 736

Davis v. Monroe County Board of Education, (1999) 526 U.S. 629

Gebser v. Lago Vista Independent School District, (1998) 524 U.S. 274

Oona by Kate S. v. McCaffrey, (1998, 9th Cir.) 143 F.3d 473

Doe v. Petaluma City School District, (1995, 9th Cir.) 54 F.3d 1447

SEXUAL HARASSMENT (continued)

Legal Reference (continued)

Management Resources:

CSBA PUBLICATIONS

Providing a Safe, Nondiscriminatory School Environment for Transgender and Gender-Nonconforming Students, Policy Brief, February 2014

Safe Schools: Strategies for Governing Boards to Ensure Student Success, 2011

U.S. DEPARTMENT OF EDUCATION, OFFICE FOR CIVIL RIGHTS PUBLICATIONS

Dear Colleague Letter: Transgender Students, May 2016

Examples of Policies and Emerging Practices for Supporting Transgender Students, May 2016

Dear Colleague Letter: Title IX Coordinators, April 2015

Questions and Answers on Title IX and Sexual Violence, April 2014

Dear Colleague Letter: Sexual Violence, April 4, 2011

Sexual Harassment: It's Not Academic, September 2008

Revised Sexual Harassment Guidance: Harassment of Students by School Employees, Other Students, or Third Parties, January 2001

OFFICE FOR CIVIL RIGHTS PUBLICATIONS

Sexual Harassment: It's Not Academic, September 2008

Revised Sexual Harassment Guidance, January 2001

WEB SITES

CSBA: <http://www.csba.org>

California Department of Education: <http://www.cde.ca.gov>

U.S. Department of Education, Office for Civil Rights:

<http://www.ed.gov/about/offices/list/ocr/index.html>

Policy

Adopted: November 2, 2011

Revised: May 16, 2018

OXNARD SCHOOL DISTRICT

Oxnard, California

SEXUAL HARASSMENT

The district designates the following individual(s) as the responsible employee(s) to coordinate its efforts to comply with Title IX of the Education Amendments of 1972 and California Education Code 234.1, as well as to investigate and resolve sexual harassment complaints under AR 1312.3 - Uniform Complaint Procedures. The coordinator/compliance officer(s) may be contacted at:

Assistant Superintendent, Human Resources and Support Services

(title or position)

1051 South A Street, Oxnard, California 93030

(address)

(805) 385.1501 extension 2050

(telephone number)

(email)

(cf. 1312.3 - Uniform Complaint Procedures)

Prohibited sexual harassment includes, but is not limited to, unwelcome sexual advances, unwanted requests for sexual favors, or other unwanted verbal, visual, or physical conduct of a sexual nature made against another person of the same or opposite sex in the educational setting, ~~when made on the basis of sex and~~ under any of the following conditions: (Education Code 212.5; 5 CCR 4916)

1. Submission to the conduct is explicitly or implicitly made a term or condition of a student's academic status or progress
2. Submission to or rejection of the conduct by a student is used as the basis for academic decisions affecting the student
3. The conduct has the purpose or effect of having a negative impact on the student's academic performance or of creating an intimidating, hostile, or offensive educational environment
4. Submission to or rejection of the conduct by the student is used as the basis for any decision affecting the student regarding benefits and services, honors, programs, or activities available at or through any district program or activity

(cf. 5131 - Conduct)

(cf. 5131.2 - Bullying)

(cf. 5137 - Positive School Climate)

(cf. 5145.3 - Nondiscrimination/Harassment)

(cf. 6142.1 - Sexual Health and HIV/AIDS Prevention Instruction)

SEXUAL HARASSMENT (continued)

Examples of types of conduct which are prohibited in the district and which may constitute sexual harassment include, but are not limited to:

1. Unwelcome leering, sexual flirtations, or propositions
2. Unwelcome sexual slurs, epithets, threats, verbal abuse, derogatory comments, or sexually degrading descriptions
3. Graphic verbal comments about an individual's body or overly personal conversation
4. Sexual jokes, derogatory posters, notes, stories, cartoons, drawings, pictures, obscene gestures, or computer-generated images of a sexual nature
5. Spreading sexual rumors
6. Teasing or sexual remarks about students enrolled in a predominantly single-sex class
7. Massaging, grabbing, fondling, stroking, or brushing the body
8. Touching an individual's body or clothes in a sexual way
9. Impeding or blocking movements or any physical interference with school activities when directed at an individual on the basis of sex
10. Displaying sexually suggestive objects
11. *Sexual assault, sexual battery, or sexual coercion*
12. *Electronic communications containing comments, words, or images described above*

Any prohibited conduct that occurs off campus or outside of school-related or school-sponsored programs or activities will be regarded as sexual harassment in violation of district policy if it has a continuing effect on or creates a hostile school environment for the complainant or victim of the conduct.

School-Level Complaint Process/Grievance Procedure

1. ~~**Notice and Receipt of Complaint:** Any student who believes he/she has been subjected to sexual harassment or who has witnessed sexual harassment may file a complaint with any school employee. Within 24 hours of receiving a complaint, the school employee shall report it to Principal. In addition, any school employee who observes any incident of sexual harassment involving a student shall, within 24 hours, report this observation to the Principal, whether or not the victim files a complaint.~~

SEXUAL HARASSMENT (continued)

- ~~In any case of sexual harassment involving the Principal to whom the complaint would ordinarily be made, the employee who receives the student's report or who observes the incident shall instead report to the Superintendent or designee.~~
2. ~~**Initiation of Investigation:** The Principal shall initiate an impartial investigation of an allegation of sexual harassment within five school days of receiving notice of the harassing behavior, regardless of whether a formal complaint has been filed. The district shall be considered to have "notice" of the need for an investigation upon receipt of information from a student who believes he/she has been subjected to harassment, the student's parent/guardian, an employee who received a complaint from a student, or any employee or student who witnessed the behavior.~~
- ~~— If the Principal receives an anonymous complaint or media report about alleged sexual harassment, he/she shall consider the specificity and reliability of the information, the seriousness of the alleged incident, and whether any individuals can be identified who were subjected to the alleged harassment in determining whether it is reasonable to pursue an investigation.~~
3. ~~**Initial Interview with Student:** When a student or parent/guardian has complained or provided information about sexual harassment, the Principal shall describe the district's grievance procedure and discuss what actions are being sought by the student in response to the complaint. The student who is complaining shall have an opportunity to describe the incident, identify witnesses who may have relevant information, provide other evidence of the harassment, and put his/her complaint in writing. If the student requests confidentiality, he/she shall be informed that such a request may limit the district's ability to investigate.~~
4. ~~**Investigation Process:** The Principal shall keep the complaint and allegation confidential, except as necessary to carry out the investigation or take other subsequent necessary action. (5 CCR 4964)~~

~~The Principal shall interview individuals who are relevant to the investigation, including, but not limited to, the student who is complaining, the person accused of harassment, anyone who witnessed the reported harassment, and anyone mentioned as having relevant information. The Principal may take other steps such as reviewing any records, notes, or statements related to the harassment or visiting the location where the harassment is alleged to have taken place.~~

~~When necessary to carry out his/her investigation or to protect student safety, the Principal also may discuss the complaint with the Superintendent or designee, the parent/guardian of the student who complained, the parent/guardian of the alleged harasser if the alleged harasser is a student, a teacher or staff member whose knowledge of the students involved may help in determining who is telling the truth,~~

SEXUAL HARASSMENT (continued)

~~law enforcement and/or child protective services, and district legal counsel or the district's risk manager.~~

~~(cf. 5141.4—Child Abuse Prevention and Reporting)~~

- ~~5. — **Interim Measures:** The Principal shall determine whether interim measures are necessary during and pending the results of the investigation, such as placing students in separate classes or transferring a student to a class taught by a different teacher.~~
- ~~6. — **Optional Mediation:** In cases of student to student harassment, when the student who complained and the alleged harasser so agree, the Principal may arrange for them to resolve the complaint informally with the help of a counselor, teacher, administrator, or trained mediator. The student who complained shall never be asked to work out the problem directly with the accused person unless such help is provided and both parties agree, and he/she shall be advised of the right to end the informal process at any time.~~
- ~~7. — **Factors in Reaching a Determination:** In reaching a decision about the complaint, the Principal may take into account:

 - ~~a. — Statements made by the persons identified above~~
 - ~~b. — The details and consistency of each person's account~~
 - ~~c. — Evidence of how the complaining student reacted to the incident~~
 - ~~d. — Evidence of any past instances of harassment by the alleged harasser~~
 - ~~e. — Evidence of any past harassment complaints that were found to be untrue~~~~

~~To judge the severity of the harassment, the Principal may take into consideration:~~

- ~~a. — How the misconduct affected one or more students' education~~
- ~~b. — The type, frequency, and duration of the misconduct~~
- ~~c. — The identity, age, and sex of the harasser and the student who complained, and the relationship between them~~
- ~~d. — The number of persons engaged in the harassing conduct and at whom the harassment was directed~~

SEXUAL HARASSMENT (continued)

- e. ~~The size of the school, location of the incidents, and context in which they occurred~~
 - f. ~~Other incidents at the school involving different students~~
8. ~~**Written Report on Findings and Follow-Up:** No more than 30 days after receiving the complaint, the Principal shall conclude the investigation and prepare a written report of his/her findings. This timeline may be extended for good cause. If an extension is needed, the Principal shall notify the student who complained and explain the reasons for the extension.~~
- ~~The report shall include the decision and the reasons for the decision and shall summarize the steps taken during the investigation. If sexual harassment occurred, the report shall also include any corrective actions that have or will be taken to address the harassment and prevent any retaliation or further harassment. This report shall be presented to the student who complained, the person accused, the parents/guardians of the student who complained and the student who was accused, and the Superintendent or designee.~~
- ~~In addition, the Principal shall ensure that the harassed student and his/her parent/guardian are informed of the procedures for reporting any subsequent problems. Principal shall also make follow up inquiries to see if there have been any new incidents or retaliation and shall keep a record of this information.~~

Enforcement of District Policy

~~The Superintendent or designee shall take appropriate actions to reinforce the district's sexual harassment policy. As needed, these actions may include any of the following:~~

- 1. ~~Removing vulgar or offending graffiti~~

~~(cf. 5131.5 Vandalism and Graffiti)~~

- 2. ~~Providing training to students, staff, and parents/guardians about how to recognize harassment and how to respond~~

~~(cf. 4131 Staff Development)~~

~~(cf. 4231 Staff Development)~~

~~(cf. 4331 Staff Development)~~

- 3. ~~Disseminating and/or summarizing the district's policy and regulation regarding sexual harassment~~

SEXUAL HARASSMENT (continued)

~~4. Consistent with the laws regarding the confidentiality of student and personnel records, communicating the school's response to parents/guardians and the community~~

~~(cf. 4119.23/4219.23/4319.23 Unauthorized Release of Confidential/Privileged Information)
(cf. 5125 Student Records)~~

~~5. Taking appropriate disciplinary action~~

~~In addition, disciplinary measures may be taken against any person who is found to have made a complaint of sexual harassment which he/she knew was not true.~~

~~(cf. 4118 Suspension/Disciplinary Action)
(cf. 4218 Dismissal/Suspension/Disciplinary Action)
(cf. 5144.1 Suspension and Expulsion/Due Process)
(cf. 5144.2 Suspension and Expulsion/Due Process (Students with Disabilities))~~

Reporting Process and Complaint Investigation and Resolution

Any student who believes that he/she has been subjected to sexual harassment by another student, an employee, or a third party or who has witnessed sexual harassment is strongly encouraged to report the incident to his/her teacher, the principal, or any other available school employee. Within one school day of receiving such a report, the school employee shall forward the report to the principal or the district's compliance officer identified in AR 1312.3. In addition, any school employee who observes an incident of sexual harassment involving a student shall, within one school day, report his/her observation to the principal or a district compliance officer. The employee shall take these actions, whether or not the alleged victim files a complaint.

When a report or complaint of sexual harassment involves off-campus conduct, the principal shall assess whether the conduct may create or contribute to the creation of a hostile school environment. If he/she determines that a hostile environment may be created, the complaint shall be investigated and resolved in the same manner as if the prohibited conduct occurred at school.

When a verbal or informal report of sexual harassment is submitted, the principal or compliance officer shall inform the student or parent/guardian of the right to file a formal written complaint in accordance with the district's uniform complaint procedures. Regardless of whether a formal complaint is filed, the principal or compliance officer shall take steps to investigate the allegations and, if sexual harassment is found, shall take prompt action to stop it, prevent recurrence, and address any continuing effects.

If a complaint of sexual harassment is initially submitted to the principal, he/she shall, within two school days, forward the report to the compliance officer to initiate investigation of the

SEXUAL HARASSMENT (continued)

complaint. The compliance officer shall contact the complainant and investigate and resolve the complaint in accordance with law and district procedures specified in AR 1312.3.

In investigating a sexual harassment complaint, evidence of past sexual relationships of the victim shall not be considered, except to the extent that such evidence may relate to the victim's prior relationship with the respondent.

In any case of sexual harassment involving the principal, compliance officer, or any other person to whom the incident would ordinarily be reported or filed, the report may instead be submitted to the Superintendent or designee who shall determine who will investigate the complaint.

(cf. 5141.4 - Child Abuse Prevention and Reporting)

Confidentiality

All complaints and allegations of sexual harassment shall be kept confidential except as necessary to carry out the investigation or take other subsequent necessary action. (5 CCR 4964)

However, when a complainant or victim of sexual harassment notifies the district of the harassment but requests confidentiality, the compliance officer shall inform him/her that the request may limit the district's ability to investigate the harassment or take other necessary action. When honoring a request for confidentiality, the district will nevertheless take all reasonable steps to investigate and respond to the complaint consistent with the request.

When a complainant or victim of sexual harassment notifies the district of the harassment but requests that the district not pursue an investigation, the district will determine whether or not it can honor such a request while still providing a safe and nondiscriminatory environment for all students.

*(cf. 4119.23/4219.23/4319.23 - Unauthorized Release of Confidential/Privileged Information)
(cf. 5125 - Student Records)*

Response Pending Investigation

When an incident of sexual harassment is reported, the principal or designee, in consultation with the compliance officer, shall determine whether interim measures are necessary pending the results of the investigation. The principal/designee or compliance officer shall take immediate measures necessary to stop the harassment and protect students and/or ensure their access to the educational program. To the extent possible, such interim measures shall not disadvantage the complainant or victim of the alleged harassment. Interim measures may include placing the individuals involved in separate classes or transferring a student to a class taught by a different teacher, in accordance with law and Board policy. The school should notify the individual who was harassed of his/her options to avoid contact with the

SEXUAL HARASSMENT (continued)

alleged harasser and allow the complainant to change academic and extracurricular arrangements as appropriate. The school should also ensure that the complainant is aware of the resources and assistance, such as counseling, that are available to him/her. As appropriate, such actions shall be considered even when a student chooses to not file a formal complaint or the sexual harassment occurs off school grounds or outside school-sponsored or school-related programs or activities.

Notifications

A copy of the district's sexual harassment policy and regulation shall:

1. Be included in the notifications that are sent to parents/guardians at the beginning of each school year (Education Code 48980; 5 CCR 4917)

(cf. 5145.6 - Parental Notifications)

2. Be displayed in a prominent location in the main administrative building or other area where notices of district rules, regulations, procedures, and standards of conduct are posted (Education Code 231.5)

A copy of the district's sexual harassment policy and regulation shall be posted on district and school web sites and, when available, on district-supported social media.

(cf. 1113 - District and School Web Sites)

(cf. 1114 - District-Sponsored Social Media)

3. Be provided as part of any orientation program conducted for new students at the beginning of each quarter, semester, or summer session (Education Code 231.5)
4. Appear in any school or district publication that sets forth the school's or district's comprehensive rules, regulations, procedures, and standards of conduct (Education Code 231.5)
5. Be included in the student handbook
6. Be provided to employees and employee organizations

OSD BOARD AGENDA ITEM

Name of Contributor: **Dr. Jesus Vaca**

Date of Meeting: **May 2, 2018**

- A. Preliminary _____
Study Session _____
Report _____
- B. Hearing: _____
- C. Consent Agenda _____
Agreement Category:
_____ Academic
_____ Enrichment
_____ Special Education
_____ Support Services
_____ Personnel
_____ Legal
_____ Facilities
- D. Action Items _____
- E. Approval of Minutes _____
- F. Board Policies 1st Reading X 2nd Reading _____

NONDISCRIMINATION IN DISTRICT PROGRAMS AND ACTIVITIES – BP 0410: Revision (Vaca)

The policy has been updated to reflect new laws, as recommended by the California School Boards Association (CSBA).

FISCAL IMPACT:

None

RECOMMENDATION:

It is the recommendation of the Assistant Superintendent, Human Resources that the Board of Trustees review the revised policy, as presented.

ADDITIONAL MATERIAL(S):

- BP 0410 Nondiscrimination in District Programs and Activities (five pages)

NONDISCRIMINATION IN DISTRICT PROGRAMS AND ACTIVITIES

The ~~Board of Trustees~~ *Governing Board* is committed to providing equal opportunity for all individuals in education. District programs, activities, and practices shall be free from *unlawful* discrimination, *including discrimination against an individual or group* based on race, color, ancestry, *nationality*, national origin, ethnic group identification, *age, religion*, marital, *pregnancy*, or parental status, physical or mental disability, sex, sexual orientation, gender, gender identity or expression, or genetic information; ~~the~~ *a* perception of one or more of such characteristics; or association with a person or group with one or more of these actual or perceived characteristics.

(cf. 1240 - Volunteer Assistance)

(cf. 4030 - Nondiscrimination in Employment)

(cf. 4032 - Reasonable Accommodation)

(cf. 4033 - Lactation Accommodation)

~~*(cf. 4161.8/4261.8/4361.8 - Family Care and Medical Leave)*~~

(cf. 4119.11/4219.11/4319.11 - Sexual Harassment)

(cf. 4161.8/4261.8/4361.8 - Family Care and Medical Leave)

(cf. 5131.2 - Bullying)

(cf. 5145.3 - Nondiscrimination/Harassment)

(cf. 5145.7 - Sexual Harassment)

(cf. 5146 - Married/Pregnant/Parenting Students)

(cf. 6145 - Extracurricular and Cocurricular Activities)

(cf. 6145.2 - Athletic Competition)

(cf. 6164.4 - Identification and Evaluation of Individuals for Special Education)

(cf. 6164.6 - Identification and Education Under Section 504)

(cf. 6178 - Career Technical Education)

(cf. 6200 - Adult Education)

District programs and activities shall also be free of any racially derogatory or discriminatory school or athletic team names, mascots, or nicknames.

Annually, the Superintendent or designee shall review district programs and activities to ensure the removal of any *derogatory or discriminatory name, image, practice, or other barrier* that may unlawfully prevent an individual or group in any of the protected categories stated above from accessing district programs and activities, ~~including the use of facilities~~. He/she shall take prompt, reasonable actions to remove any identified barrier. The Superintendent or designee shall report his/her findings and recommendations to the Board after each review.

(cf. 1330 - Use of Facilities)

All allegations of unlawful discrimination in district programs and activities shall be investigated and resolved in accordance with the procedures specified in AR 1312.3 - Uniform Complaint Procedures.

(cf. 1312.3 - Uniform Complaint Procedures)

NONDISCRIMINATION IN DISTRICT PROGRAMS AND ACTIVITIES (continued)

Pursuant to 34 CFR 104.8 and 34 CFR 106.9, the Superintendent or designee shall notify students, parents/guardians, employees, employee organizations, applicants for admission and employment, and sources of referral for applicants about the district's policy on nondiscrimination and ~~other~~-related complaint procedures. Such notification shall be included in each announcement, bulletin, catalog, *handbook*, application form, or other materials distributed to these groups; *and, as applicable, to the public. As appropriate, such notification shall be posted in district schools and offices, including staff lounges, student government meeting rooms, and other prominent locations and shall be posted on the district's web site and, when available, district-supported social media.*

~~(cf. 1312.3 – Uniform Complaint Procedures)~~
 (cf. 1113 - District and School Web Sites)
 (cf. 1114 - District-Sponsored Social Media)
~~(cf. 4031 – Complaints Concerning Discrimination in Employment)~~
 (cf. 4112.9/4214.9/4312.9 – Employee Notifications)
 (cf. 5145.6 – Parental Notifications)

The district's nondiscrimination policy and related informational materials shall be published in a format that parent/guardians can understand. In addition, when 15 percent or more of a school's students speaks a single primary language other than English, those materials shall be translated into that other language.

Access for Individuals with Disabilities

District programs and facilities, viewed in their entirety, shall be in compliance with the Americans with Disabilities Act (*ADA*) and any implementing standards and/or regulations. *When structural changes to existing district facilities are needed to provide individuals with disabilities access to programs, services, activities, or facilities, the Superintendent or designee shall develop a transition plan that sets forth the steps for completing the changes.*

~~(cf. 6132.2 6163.2 – Animals at School)~~
 (cf. 7110 – Facilities Master Plan)
 (cf. 7111 – Evaluating Existing Buildings)

The Superintendent or designee shall ensure that the district provides appropriate auxiliary aids and services when necessary to afford individuals with disabilities equal opportunity to participate in or enjoy the benefits of a service, program, or activity. These aids and services may include, but are not limited to, qualified interpreters or readers, assistive listening devices, *assistive technologies or other modifications to increase accessibility to district and school web sites*, notetakers, written materials, taped text, and Braille or large print materials. *Individuals with disabilities shall notify the Superintendent or principal if they have a disability that requires special assistance or services. Reasonable notification should be given prior to the school-sponsored function, program, or meeting.*

(cf. 6020 - Parent Involvement)
 (cf. 9320 - Meetings and Notices)
 (cf. 9322 - Agenda/Meeting Materials)

NONDISCRIMINATION IN DISTRICT PROGRAMS AND ACTIVITIES (continued)

~~Individuals with disabilities shall notify the Superintendent or principal if they have a disability that requires special assistance or services. Reasonable notification should be given prior to the school-sponsored function, program, or meeting.~~

~~(cf. 9320 Meetings and Notices)~~

~~(cf. 9322 Agenda/Meeting Materials)~~

The individual identified in AR 1312.3 - Uniform Complaint Procedures as the employee responsible for coordinating the district's response to complaints and for complying with state and federal civil rights laws is hereby designated as the district's ADA coordinator. He/she shall receive and address requests for accommodation submitted by individuals with disabilities, and shall investigate and resolve complaints regarding their access to district programs, services, activities, or facilities.

Assistant Superintendent, Human Resources and Support Services

(title or position)

1051 South A Street, Oxnard, CA 93030

(address)

(805) 385.1501 extension 2051

(telephone number)

(email)

Legal Reference:

EDUCATION CODE

200-262.4 Prohibition of discrimination

48985 Notices to parents in language other than English

51007 Legislative intent: state policy

GOVERNMENT CODE

11000 Definitions

11135 Nondiscrimination in programs or activities funded by state

11138 Rules and regulations

12900-12996 Fair Employment and Housing Act

54953.2 Brown Act compliance with Americans with Disabilities Act

PENAL CODE

422.55 Definition of hate crime

422.6 Interference with constitutional right or privilege

CODE OF REGULATIONS, TITLE 5

4600-4687 Uniform complaint procedures

4900-4965 Nondiscrimination in elementary and secondary education ~~programs receiving state financial assistance~~

UNITED STATES CODE, TITLE 20

1400-1482 Individuals with Disabilities in Education Act

1681-1688 Discrimination based on sex or blindness, Title IX

2301-2415 Carl D. Perkins Vocational and Applied Technology Act

6311 State plans

6312 Local education agency plans

NONDISCRIMINATION IN DISTRICT PROGRAMS AND ACTIVITIES (continued)

Legal Reference (continued):

UNITED STATES CODE, TITLE 29

794 Section 504 of the Rehabilitation Act of 1973

UNITED STATES CODE, TITLE 42

2000d-2000d-7 Title VI, Civil Rights Act of 1964

2000e-2000e-17 Title VII, Civil Rights Act of 1964 as amended

2000h-2000h-6 Title IX

12101-12213 Americans with Disabilities Act

CODE OF FEDERAL REGULATIONS, TITLE 28

35.101-35.190 Americans with Disabilities Act

36.303 Auxiliary aids and services

CODE OF FEDERAL REGULATIONS, TITLE 34

100.1-100.13 Nondiscrimination in federal programs, effectuating Title VI

104.1-104.39 Section 504 of the Rehabilitation Act of 1973

106.1-106.61 Discrimination on the basis of sex, effectuating Title IX, especially:

106.9 Dissemination of policy

Management Resources:

CSBA PUBLICATIONS

Updated Legal Guidance: Protecting Transgender and Gender Nonconforming Students Against Sex Discrimination, July 2016

Providing a Safe, Nondiscriminatory School Environment for Transgender and Gender-Nonconforming Students, Policy Brief, February 2014

Interim Guidance Regarding Transgender Students, Privacy, and Facilities, September 27, 2013

Safe Schools: Strategies for Governing Board to Ensure Student Success, 2011

CALIFORNIA DEPARTMENT OF FAIR EMPLOYMENT AND HOUSING PUBLICATIONS

California Law Prohibits Workplace Discrimination and Harassment

U.S. DEPARTMENT OF EDUCATION, OFFICE FOR CIVIL RIGHTS PUBLICATIONS

Dear Colleague Letter: Transgender Students, May 2016

Examples of Policies and Emerging Practices for Supporting Transgender Students, May 2016

Dear Colleague Letter: Title IX Coordinators, April 2015

Dear Colleague Letter: Harassment and Bullying, October 2010

Dear Colleague Letter: Electronic Book Readers, June 29, 2010

Notice of Non-Discrimination, January, 1999

Protecting Students from Harassment and Hate Crime, January, 1999

Nondiscrimination in Employment Practices in Education, August, 1991

U.S. DEPARTMENT OF JUSTICE PUBLICATIONS

2010 ADA Standards for Accessible Design, September 2010

Accessibility of State and Local Government Websites to People with Disabilities, June 2003

WEB SITES

CSBA : <http://www.csba.org>

California Department of Education: <http://www.cde.ca.gov>

California Department of Fair Employment and Housing: <http://www.dfeh.ca.gov>

Safe Schools Coalition: <http://www.casafeschoolscoalition.org>

Pacific ADA Center: <http://adapacific.org>

U.S. Department of Education, Office for Civil Rights:

<http://www.ed.gov/about/offices/list/ocr/index.html>

U.S. Department of Justice, Civil Rights Division, Americans with Disability Act: <http://www.ada.gov>

U.S. Equal Employment Opportunity Commission: <http://www.eeoc.gov>

World Wide Web Consortium, Web Accessibility Initiative: <http://www.w3.org/wai>

NONDISCRIMINATION IN DISTRICT PROGRAMS AND ACTIVITIES (continued)

Policy

adopted: October 19, 2011

revised: January 15, 2014, September 3, 2014, *May 16, 2018*

OXNARD SCHOOL DISTRICT

Oxnard, California

OSD BOARD AGENDA ITEM

Name of Contributor: **Dr. Jesus Vaca**

Date of Meeting: **May 2, 2018**

- A. Preliminary _____
Study Session _____
Report _____
- B. Hearing: _____
- C. Consent Agenda _____
Agreement Category:
_____ Academic
_____ Enrichment
_____ Special Education
_____ Support Services
_____ Personnel
_____ Legal
_____ Facilities
- D. Action Items _____
- E. Approval of Minutes _____
- F. Board Policies 1st Reading X 2nd Reading _____

UNIFORM COMPLAINT PROCEDURES – BP and AR 1312.3: Revision (Vaca)

The policy and regulation have been updated to reflect new laws, as recommended by the California School Boards Association (CSBA).

FISCAL IMPACT:

None

RECOMMENDATION:

It is the recommendation of the Assistant Superintendent, Human Resources that the Board of Trustees review the revised policy and regulation, as presented.

ADDITIONAL MATERIAL(S):

- BP 1312.3 Uniform Complaint Procedures (seven pages)
- AR 1312.3 Uniform Complaint Procedures (20 pages)

UNIFORM COMPLAINT PROCEDURES

The Governing Board recognizes that the district has the primary responsibility to ~~comply~~ *ensure compliance* with applicable state and federal laws and regulations governing educational programs. ~~The district shall investigate complaints alleging failure to comply with such laws and/or alleging unlawful discrimination, harassment, intimidation, and bullying, and shall seek to resolve those complaints in accordance with the district's uniform complaint procedures. (5 CCR 4600-4670) A complaint may also be filed regarding violations of state laws or regulations related to pupil fees. The Board encourages early resolution of complaints whenever possible. To resolve complaints which may require a more formal process, the Board adopts the uniform system of complaint processes specified in 5 CCR 4600-4670 and the accompanying administrative regulation.~~

The district's uniform complaint procedures (UCP) shall be used to investigate and resolve the following complaints:

1. Any complaint alleging district violation of applicable state or federal law or regulations governing ~~consolidated categorical aid programs, after school education and safety programs, tobacco use prevention education, compensatory education, Every Child Succeeds Act/No Child Left Behind, migrant education, child care and development programs, child nutrition programs, and special education programs and any other district implemented program which is listed in Education Code 64000(a).~~ *(5 CCR 4610) After School Education and Safety programs, agricultural vocational education, American Indian education centers and early childhood education program assessments, bilingual education, peer assistance and review programs for teachers, career technical and technical education and training programs, child care and development programs, child nutrition programs, compensatory education, consolidated categorical aid programs, Economic Impact Aid, English learner programs, federal education programs in Title I-VII, migrant education, Regional Occupational Centers and Programs, school safety plans, special education programs, State Preschool Programs, Tobacco-Use Prevention Education programs, and any other district-implemented program which is listed in Education Code 64000(a).*

(cf. 3553 - Free and Reduced Price Meals)

(cf. 3555 - Nutrition Program Compliance)

(cf. 5131.62 - Tobacco)

~~*(cf. 5141.4 - Child Abuse Prevention and Reporting)*~~

(cf. 5148 - Child Care and Development)

(cf. 5148.2 - Before/After School Programs)

(cf. 5148.3 - Preschool/Early Childhood Education)

(cf. 6159 - Individualized Education Program)

(cf. 6171 - Title I Programs)

(cf. 6174 - Education for English Language Learners)

(cf. 6175 - Migrant Education Program)

UNIFORM COMPLAINT PROCEDURES (continued)

2. Any complaint alleging the occurrence of unlawful discrimination (such as discriminatory harassment, intimidation, or bullying) against any *student, employee, or other person participating* in district programs and activities, including, but not limited to, those programs or activities funded directly by or that receive or benefit from any state financial assistance, based on the person's actual or perceived characteristics of race or ethnicity, color, ancestry, nationality, national origin, *immigration status*, ethnic group identification, age, religion, marital ~~or parental~~ status, *pregnancy, parental status*, physical or mental disability, sex, sexual orientation, gender, gender identity, gender expression, or genetic information, or any other characteristic identified in Education Code 200 or 220, Government Code 11135, or Penal Code 422.55, or based on his/her association with a person or group with one or more of these actual or perceived characteristics (5 CCR 4610).

(cf. 0410 - Nondiscrimination in District Programs and Activities)

~~*(cf. 4030 - Nondiscrimination in Employment)*~~

(cf. 5145.3 - Nondiscrimination/Harassment)

(cf. 5145.7 - Sexual Harassment)

3. Any complaint alleging district noncompliance with the requirement to provide 2reasonable accommodation to a lactating student on school campus to express breast milk, breastfeed an infant child, or address other breastfeeding-related needs of the student (Education Code 222).

(cf. 5146 - Married/Pregnant/Parenting Students)

4. Any complaint alleging district noncompliance with the prohibition against requiring students to pay fees, deposits, or other charges for participation in educational activities (5 CCR 4610).

(cf. 3260 - Fees and Charges)

(cf. 3320 - Claims and Actions Against the District)

5. Any complaint alleging district noncompliance with legal requirements related to the implementation of the local control and accountability plan (Education Code 52075).

(cf. 0460 - Local Control and Accountability Plan)

6. Any complaint, by or on behalf of any student who is a foster youth, alleging district noncompliance with any legal requirement applicable to the student regarding placement decisions, the responsibilities of the district's educational liaison to the student, the award of credit for coursework satisfactorily completed in another school or district, school transfer, or the grant of an exemption from Board-imposed graduation requirements (Education Code 48853, 48853.5, 49069.5, 51225.1, 51225.2).

(cf. 6173.1 - Education for Foster Youth)

UNIFORM COMPLAINT PROCEDURES (continued)

7. Any complaint, by or on behalf of a homeless student as defined in 42 USC 11434a or a former juvenile court school student alleging district noncompliance with any requirement applicable to the student regarding the award of credit for coursework

satisfactorily completed in another school or district or the grant of an exemption from Board-imposed graduation requirements (Education Code 51225.1, 51225.2).

(cf. 6173 - Education for Homeless Children)

(cf. 6173.3 - Education for Juvenile Court School Students)

8. ~~Any complaint alleging district noncompliance with the requirements of Education Code 51228.1 and 51228.2 that prohibit the assignment of a student to a course without educational content for more than one week in any semester or to a course the student has previously satisfactorily completed, without meeting specified conditions).~~
(Education Code 51228.3)

~~*(cf. 6152 - Class Assignment)*~~

~~*(cf. 6142.7 - Physical Education and Activity)*~~

9. Any complaint alleging retaliation against a complainant or other participant in the complaint process or anyone who has acted to uncover or report a violation subject to this policy.
10. Any other complaint as specified in a district policy.

~~The Board prohibits any form of retaliation against any complainant in the complaint process. The Board shall ensure that complainants are protected from retaliation and the identity of a complainant alleging discrimination, harassment, intimidation, or bullying, will remain confidential as appropriate. Participation in the complaint process shall not in any way affect the status, grades, or work assignments of the complainant.~~

~~The Board encourages the early, informal resolution of complaints at the site level whenever possible.~~

~~The Board recognizes that a neutral mediator can often suggest a compromise that is agreeable to all parties in a dispute. In accordance with uniform complaint procedure, whenever all parties to a complaint agree to try to resolve the problem through mediation, the Superintendent or designee shall initiate that process. The Superintendent or designee shall ensure that the results are consistent with state and federal laws and regulations.~~

~~In investigating complaints, the confidentiality of the parties involved and the integrity of the process shall be protected. As appropriate, the Superintendent or designee may keep the identity of a complainant confidential to the extent that the investigation of the complaint is not obstructed.~~

UNIFORM COMPLAINT PROCEDURES (continued)

~~The Board acknowledges and respects every individual's right to privacy. Discrimination, harassment, intimidation, or bullying complaints shall be investigated in a manner that protects the confidentiality of the parties and the integrity of the process. This may include keeping the identity of the complainant confidential, as appropriate and except to the extent necessary to carry out the investigation or proceedings, as determined by the Superintendent or designee, on a case-by-case basis.~~

The Board recognizes that alternative dispute resolution (ADR) can, depending on the nature of the allegations, offer a process to reach a resolution to the complaint that is acceptable to all parties. ADR such as mediation may be offered to resolve complaints that involve more than one student and no adult. However, mediation shall not be offered or used to resolve any complaint involving sexual assault or where there is a reasonable risk that a party to the mediation would feel compelled to participate. The Superintendent or designee shall ensure that the use of ADR is consistent with state and federal laws and regulations.

The district shall protect all complainants from retaliation. In investigating complaints, the confidentiality of the parties involved shall be protected as required by law. For any complaint alleging retaliation or unlawful discrimination (such as discriminatory harassment, intimidation, or bullying), the Superintendent or designee shall keep the identity of the complainant, and/or the subject of the complaint if he/she is different from the complainant, confidential when appropriate and as long as the integrity of the complaint process is maintained.

(cf. 4119.23/4219.23/4319.23 - Unauthorized Release of Confidential/Privileged Information)

(cf. 5125 - Student Records)

(cf. 9011 - Disclosure of Confidential/Privileged Information)

~~Unlawful discrimination, harassment, intimidation or bullying complaints shall be filed no later than six months from the date the alleged discrimination, harassment, intimidation, or bullying occurred, or six months from the date the complainant first obtained knowledge of the facts of the alleged discrimination, harassment, intimidation, or bullying.~~

~~The district's Williams uniform complaint procedures, AR 1312.4, shall be used to investigate and resolve any complaint related to the following:~~

- ~~1. Sufficiency of textbooks or instructional materials~~
- ~~2. Emergency or urgent facilities conditions that pose a threat to the health or safety of students or staff~~
- ~~3. Teacher vacancies and misassignments~~

When an allegation that is not subject to the UCP is included in a UCP complaint, the district shall refer the non-UCP allegation to the appropriate staff or agency and shall investigate and, if appropriate, resolve the UCP-related allegation(s) through the district's UCP.

UNIFORM COMPLAINT PROCEDURES (continued)

The Superintendent or designee shall provide training to district staff to ensure awareness and knowledge of current law and related requirements, including the steps and timelines specified in this policy and the accompanying administrative regulation.

(cf. 4131 - Staff Development)

(cf. 4231 - Staff Development)

(cf. 4331 - Staff Development)

The Superintendent or designee shall maintain records of all UCP complaints and the investigations of those complaints in accordance with applicable law and district policy.

(cf. 3580 - District Records)

Non-UCP Complaints

The following complaints shall not be subject to the district's UCP but shall be referred to the specified agency: (5 CCR 4611)

1. *Any complaint alleging child abuse or neglect shall be referred to the County Department of Social Services, the County Protective Services Division, and the appropriate law enforcement agency.*

(cf. 5141.4 - Child Abuse Prevention and Reporting)

2. *Any complaint alleging health and safety violations by a child development program shall, for licensed facilities, be referred to Department of Social Services and shall, for licensing-exempt facilities, be referred to the appropriate Child Development regional administrator.*

3. *Any complaint alleging fraud shall be referred to the Legal, Audits and Compliance Branch of the California Department of Education.*

Any complaint alleging employment discrimination or harassment shall be investigated and resolved by the district in accordance with the procedures specified in AR 4030 - Nondiscrimination in Employment.

Any complaint related to sufficiency of textbooks or instructional materials, emergency or urgent facilities conditions that pose a threat to the health or safety of students or staff, or teacher vacancies and misassignments shall be investigated and resolved in accordance with the procedures in AR 1312.4 - Williams Uniform Complaint Procedures. (Education Code 35186)

(cf. 1312.4 - Williams Uniform Complaint Procedures)

UNIFORM COMPLAINT PROCEDURES (continued)*Legal Reference:*EDUCATION CODE

200-262.4 Prohibition of discrimination
 222 Reasonable accommodations; lactating students
 8200-8498 Child care and development programs
 8500-8538 Adult basic education
 18100-18203 School libraries
 32280-32289 School safety plan, uniform complaint procedure
 33380-33384 California Indian Education Centers
 35186 Williams uniform complaint procedure
 44500-44508 California Peer Assistance and Review Program for Teachers
 48853-48853.5 Foster youth
 48985 Notices in language other than English
 49010-49013 Student fees
 49060-49079 Student records
 49069.5 Rights of parents
 49490-49590 Child nutrition programs
 51210 Courses of study grades 1-6
 51223 Physical education, elementary schools
 51225.1-51225.2 Foster youth and homeless children; course credits; graduation requirements
~~51228.1-51228.3 Course periods without educational content~~
 52060-52077 Local control and accountability plan, especially
 52075 Complaint for lack of compliance with local control and accountability plan requirements
 52160-52178 Bilingual education programs
~~52300-52490 Career technical education~~
~~52500-52616.24 Adult schools~~
~~52800-52870 School based coordinated programs~~
 54000-54028 Economic impact aid programs
 54440-54445 Migrant education
 54460-54529 Compensatory education programs
 56000-56867 Special education programs
 59000-59300 Special schools and centers
 64000-64001 consolidated application process

GOVERNMENT CODE

11135 Nondiscrimination in programs or activities funded by state
 12900-12996 Fair Employment Housing Act

HEALTH AND SAFETY CODE

104420 Tobacco-Use Prevention Education

PENAL CODE

422.55 Hate crime; definition
 422.6 Interference with constitutional right or privilege

CODE OF REGULATIONS, TITLE 2

11023 Harassment and discrimination prevention and correction

CODE OF REGULATIONS, TITLE 5

3080 Application of section

4600-4687 Uniform complaint procedures

4900-4965 Nondiscrimination in elementary and secondary education programs

UNITED STATES CODE, TITLE 20

1221 Application of laws

1232g Family Educational Rights and Privacy Act

1681-1688 Title IX of the Education Amendments of 1972

6301-6577 Title I basic programs

~~6601-6777 Title II preparing and recruiting high quality teachers and principals~~

UNIFORM COMPLAINT PROCEDURES (continued)

6801-6871 Title III language instruction for limited English proficient and immigrant students
7101-7184 Safe and Drug-Free Schools and Communities Act
7201-7283g Title V promoting informed parental choice and innovative programs
7301-7372 Title V rural and low-income school programs
12101-12213 Title II equal opportunity for individuals with disabilities
UNITED STATES CODE, TITLE 29
794 Sections 504 of Rehabilitation Act of 1973
UNITED STATES CODE, TITLE 42
2000d-2000e-17 Title VI and Title VII Civil Rights Act of 1964, as amended
2000h-2-2000h-6 Title IX of the Civil Rights Act of 1964
6101-6107 Age Discrimination Act of 1975
CODE OF FEDERAL REGULATIONS, TITLE 28
35.107 Nondiscrimination on basis of disability; complaints
CODE OF FEDERAL REGULATIONS, TITLE 34
99.1-99.67 Family Educational Rights and Privacy Act
100.3 Prohibition of discrimination on basis of race, color or national origin
104.7 Designation of responsible employee for Section 504
106.8 Designation of responsible employee for Title IX
106.9 Notification of nondiscrimination on basis of sex
110.25 Notification of nondiscrimination on the basis of age

Management Resources:

CALIFORNIA DEPARTMENT OF EDUCATION PUBLICATIONS

Sample UCP Board Policies and Procedures

U.S. DEPARTMENT OF EDUCATION, OFFICE FOR CIVIL RIGHTS PUBLICATIONS

Dear Colleague Letter: Title IX Coordinators, April 2015

Questions and Answers on Title IX and Sexual Violence, April 2014

Dear Colleague Letter: Bullying of Students with Disabilities, August 2013

Dear Colleague Letter: Sexual Violence, April 2011

Dear Colleague Letter: Harassment and Bullying, October 2010

Revised Sexual Harassment Guidance: Harassment of Students by School Employees, Other Students, or Third Parties, January 2001

U.S. DEPARTMENT OF JUSTICE PUBLICATIONS

Guidance to Federal Financial Assistance Recipients Regarding Title VI Prohibition against National Origin Discrimination Affecting Limited English Proficient Persons, 2002

WEB SITES

CSBA: <http://www.csba.org>

California Department of Education: <http://www.cde.ca.gov>

Family Policy Compliance Office: <http://familypolicy.ed.gov>

U.S. Department of Education, Office for Civil Rights:

<http://www.ed.gov/about/offices/list/ocr/index.html>

U.S. Department of Justice: <http://www.justice.gov>

Policy

Adopted: October 19, 2011

Revised: January 16, 2013; June 26, 2013; September 4, 2013; August 24, 2016;

January 18, 2017; May 16, 2018

OXNARD SCHOOL DISTRICT

Oxnard, California

UNIFORM COMPLAINT PROCEDURES (continued)

~~This document presents information about how the Oxnard School District processes UCP complaints concerning particular programs or activities in which we receive state or federal funding. A complaint is a written and signed statement by a complainant alleging a violation of federal or state laws or regulations, including the prohibition against requiring students to pay fees, deposits, or other charges for participating in educational activities, which may include an allegation of unlawful discrimination, harassment, intimidation, and bullying. A complainant is any individual, including a person's duly authorized representative or an interested third party, public agency, or organization who files a written complaint alleging violation of federal or state laws or regulations, including the prohibition against requiring students to pay fees, deposits, or other charges for participating in educational activities, and/or allegations of unlawful discrimination, harassment, intimidation, and bullying in programs and activities funded directly by the state or receiving any financial assistance from the state. If the complainant is unable to put the complaint in writing, due to conditions such as a disability or illiteracy, the public agency shall assist the complainant in the filing of the complaint.~~

~~Programs or activities in which the Oxnard School District receives state or federal funding are:~~

- ~~● Consolidated Categorical Aid Programs~~
- ~~● Migrant Education~~
- ~~● Child Care and Developmental Programs~~
- ~~● Child Nutrition Programs~~
- ~~● Special Education Programs~~
- ~~● Safety Planning Requirements~~

~~This document also applies to the filing of complaints which allege unlawful discrimination (such as harassment, intimidation, and bullying) or retaliation against any protected group, including those with actual or perceived characteristics such as age, ancestry, color, ethnic group identification, gender expression, gender identity, gender, disability, nationality, national origin, race or ethnicity, religion, sex, sexual orientation, marital or parental status, or genetic information or on the basis of a person's association with a person or group with one or more of these actual or perceived characteristics, in any program or activity conducted by a local agency, which is funded directly by, or that receives or benefits from any state financial assistance.~~

~~The following complaints shall be referred to other agencies for appropriate resolution and are not subject to our UCP process set forth in this document unless these procedures are made applicable by separate interagency agreements:~~

- ~~1. Allegations of child abuse shall be referred to County Dept. of Social Services (DSS), Protective Services Division or appropriate law enforcement agency.~~
- ~~2. Health and safety complaints regarding a Child Development Program shall be referred to Dept. of Social Services for licensed facilities, and to the appropriate Child Development regional administrator for licensing exempt facilities.~~

UNIFORM COMPLAINT PROCEDURES (continued)

- 3. ~~Employment discrimination complaints shall be sent to the State Dept. of Fair Employment and Housing (DFEH).~~
- 4. ~~Allegations of fraud shall be referred to the Legal, Audits and Compliance Branch in the California Department of Education (CDE).~~

The responsibilities of the Oxnard School District

~~The Oxnard School District has the primary responsibility to ensure compliance with applicable state and federal laws and regulations. We shall investigate complaints alleging failure to comply with applicable state and federal laws and regulations, the prohibition against requiring students to pay fees, deposits, or other charges for participating in educational activities and/or alleging discrimination, harassment, intimidation, and bullying and seek to resolve those complaints in accordance with our UCP procedures.~~

~~Our UCP policies shall ensure that complainants are protected from retaliation and that the identity of a complainant alleging discrimination, harassment, intimidation, and bullying remain confidential as appropriate. We submitted our UCP policies and procedures to our local governing board for approval and adoption (see the top of this document for final adoption date).~~

~~The person responsible for receiving and investigating complaints and ensuring our compliance with state and federal laws and regulations is:~~

Name or title: Assistant Superintendent, Human Resources and Support Services

Address: 1051 South A Street, Oxnard, CA 93030

Phone Number: (805) 385 1501 ext. 2050

~~We ensure that the person above, who is responsible for compliance and/or investigations, is knowledgeable about the laws/programs that he/she is assigned to investigate.~~

~~We shall annually notify in writing our students, employees, parents or guardians of our students, the district advisory committee, school advisory committees, appropriate private school officials or representatives, and other interested parties of our UCP process, including the opportunity to appeal to our governing board and the provisions of this document by disseminating the UCP Annual Notice to all of the above required groups each school year. An appeal is a request made in writing to a level higher than the original reviewing level by an aggrieved party requesting reconsideration or a reinvestigation of the lower adjudicating body's decision.~~

~~Our UCP Annual Notice shall also advise the recipient of any civil law remedies that may be available under state or federal discrimination, harassment, intimidation, and bullying laws, if applicable, and of the appeal pursuant to Education Code section 262.3. Our UCP Annual~~

UNIFORM COMPLAINT PROCEDURES (continued)

~~Notice shall be in English and in the primary language, pursuant to section 48985 of the Education Code, or mode of communication of the recipient of the notice.~~

~~Our UCP Annual Notice shall also advise that the U.S. Department of Education Office for Civil Rights (“OCR”) is a resource available to complainants to resolve discrimination complaints. The OCR can be contacted at:~~

~~San Francisco Office
Office for Civil Rights
U.S. Department of Education
50 Beale Street, Suite 7200
San Francisco CA 94105-1813
Telephone: 415 486 5555
FAX: 415 486 5570; TDD: 1 800 877 8339
Email: ocr.sanfrancisco@ed.gov~~

~~A copy of this UCP complaint policies and procedures document shall be available free of charge.~~

Filing a complaint with the Oxnard School District

~~Williams Complaints regarding instructional materials, emergency or urgent facilities conditions that pose a threat to the health or safety of pupils or staff, and teacher vacancies or misassignments, complaints regarding the prohibition against requiring students to pay fees, deposits, or other charges for participating in educational activities, and/or complaints that allege discrimination, harassment, intimidation, and bullying, any individual, public agency or organization may file a written complaint with our district superintendent or his or her designee alleging a matter which, if true, would constitute a violation by our LEA of federal or state law or regulation governing a program.~~

~~An investigation of alleged unlawful discrimination, harassment, intimidation, and bullying, shall be initiated by filing a complaint no later than six months from the date the alleged violation of discrimination, harassment, intimidation, or bullying occurred, or the date the complainant first obtained knowledge of the facts of the alleged violation of discrimination, harassment, intimidation, and bullying.~~

~~The time for filing may be extended in writing by our district superintendent or his or her designee, upon written request by the complainant setting forth the reasons for the extension. The period for filing may be extended by our superintendent or his or her designee for good~~

UNIFORM COMPLAINT PROCEDURES (continued)

~~cause for a period not to exceed 90 calendar days following the expiration of the six month time period. Our superintendent shall respond immediately upon a receipt of a request for extension.~~

~~An investigation regarding the prohibition against requiring students to pay fees, deposits, or other charges for participating in educational activities, shall be initiated by filing a complaint no later than one year from the date the alleged violation occurred.~~

~~The complaint shall be filed by one who alleges that he or she has personally suffered a violation requiring students to pay fees, deposits, or other charges for participating in educational activities, and/or unlawful discrimination, harassment, intimidation, and bullying or by one who believes an individual or any specific class of individuals has been subjected to a violation requiring students to pay fees, deposits, or other charges for participating in educational activities, and/or discrimination, harassment, intimidation, and bullying prohibited by this part.~~

~~An investigation of a violation requiring students to pay fees, deposits, or other charges for participating in educational activities, and/or discrimination, harassment, intimidation, and bullying complaint shall be conducted in a manner that protects confidentiality of the parties and maintains the integrity of the process.~~

~~A complaint alleging noncompliance with the law regarding the prohibition against requiring students to pay student fees, deposits, and charges or any requirement related to the LCAP may be filed anonymously if the complaint provides evidence or information leading to evidence to support an allegation of noncompliance. A complaint about a violation of the prohibition against the charging of unlawful student fees may be filed with the principal of the school or with the Superintendent or designee. However, any such complaint shall be filed no later than one year from the date the alleged violation occurred. (Education Code 49013, 52075; 5 CCR 4630)~~

~~If we find merit in a pupil fees, LCAP, and/or a Course Period without Educational Content complaint, we shall provide a remedy. Specifically, in Course Period without Educational Content complaints, the remedy shall go to the affected pupil. In LCAP and pupil fee complaints, the remedy shall go to all affected pupils, parents and guardians, which in the case of pupil fees, also includes reasonable efforts by us to ensure full reimbursement to all affected pupils, parents and guardians subject to procedures established through regulations adopted by the state board.~~

~~For complaints alleging noncompliance with the laws regarding student fees, the district shall attempt in good faith, by engaging in reasonable efforts, to identify and fully reimburse all affected students and parents/guardians who paid the unlawful student fees within one year prior to the filing of the complaint. (Education Code 49013; 5 CCR 4600)~~

~~Except for Williams Complaints, within 60 calendar days from the date of the receipt of the complaint, we shall conduct and complete an investigation of the complaint in accordance~~

UNIFORM COMPLAINT PROCEDURES (continued)

~~with our UCP policies and procedures and prepare a written Decision; also known as a final report. This time period may be extended by written agreement of the complainant.~~

~~The investigation shall include an opportunity for the complainant, or the complainant's representative, or both, to present the complaint(s) and evidence or information leading to evidence to support the allegations of non-compliance with state and federal laws and/or regulations.~~

~~Refusal by the complainant to provide the investigator with documents or other evidence related to the allegations in the complaint, or to otherwise fail or refuse to cooperate in the investigation or engage in any other obstruction of the investigation, may result in the dismissal of the complaint because of a lack of evidence to support the allegations.~~

~~Refusal by the Oxnard School District to provide the investigator with access to records and/or other information related to the allegation in the complaint, or to otherwise fail or refuse to cooperate in the investigation or engage in any other obstruction of the investigation, may result in a finding based on evidence collected that a violation has occurred and may result in the imposition of a remedy in favor of the complainant.~~

~~We shall issue a Decision based on the evidence. The Decision shall be in writing and sent to the complainant within 60 calendar days from receipt of the complaint by the local educational agency. The Decision should contain:~~

- ~~(i) the findings of fact based on the evidence gathered,~~
- ~~(ii) conclusion of law,~~
- ~~(iii) disposition of the complaint,~~
- ~~(iv) the rationale for such disposition,~~
- ~~(v) corrective actions, if any are warranted,~~
- ~~(vi) notice of the complainant's right to appeal our LEA Decision of a UCP complaint regarding all specified federal and state educational programs subject to the UCP to the District Superintendent or CDE, and~~
- ~~(vii) procedures to be followed for initiating an appeal to the District Superintendent or CDE.~~

~~Specifically, a complainant may appeal decisions and/or findings involving allegations of discrimination, harassment, intimidation, or bullying to the District Superintendent within 15 days of the issuance of the Decision. The complainant shall specify the reason(s) for~~

UNIFORM COMPLAINT PROCEDURES (continued)

~~appealing the Decision to the Superintendent and include a copy of the Decision. The Superintendent, or his/her designee, shall issue a final written letter of findings to the complainant regarding the disposition of the appeal and rationale for the disposition.~~

~~Additionally, any complainant who is dissatisfied with the district's final written decision may file an appeal in writing with the CDE within 15 calendar days of receiving the district's decision. (Education Code 222, 48853, 48853.5, 49013, 49069.5, 51223, 51225.1, 51225.2, 51228.3, 52075; 5 CCR 4632)~~

~~The written appeal shall specify the reason(s) for appealing the decision and whether the facts are incorrect and/or the law has been misapplied. The appeal shall be accompanied by a copy of the locally filed complaint and include a copy of the Decision. (5 CCR 4632).~~

~~The California Department of Education can be contacted at:~~

Office of Equal Opportunity
California Department of Education
1430 N Street
Sacramento CA 95814
Phone: 916 445 9174
Facsimile: 916 324 9818

The Superintendent or designee shall ensure that employees assigned to investigate and resolve complaints receive training and are knowledgeable about the laws and programs at issue in the complaints to which they are assigned. Training provided to such employees shall cover current state and federal laws and regulations governing the program, applicable processes for investigating and resolving complaints, including those alleging unlawful discrimination (such as discriminatory harassment, intimidation, or bullying), applicable standards for reaching decisions on complaints, and appropriate corrective measures. Assigned employees may have access to legal counsel as determined by the Superintendent or designee.

*(cf. 4331 - Staff Development)
(cf. 9124 - Attorney)*

The compliance officer or, if necessary, any appropriate administrator shall determine whether interim measures are necessary during and pending the result of an investigation. If interim measures are determined to be necessary, the compliance officer or the administrator shall consult with the Superintendent, the Superintendent's designee, or, if appropriate, the site principal to implement one or more interim measures. The interim measures shall remain in place until the compliance officer determines that they are no longer necessary or until the district issues its final written decision, whichever occurs first.

UNIFORM COMPLAINT PROCEDURES (continued)

Notifications

The district's UCP policy and administrative regulation shall be posted in all district schools and offices, including staff lounges and student government meeting rooms. (Education Code 234.1)

The Superintendent or designee shall annually provide written notification of the district's UCP to students, employees, parents/guardians of district students, district advisory committee members, school advisory committee members, appropriate private school officials or representatives, and other interested parties. The notification shall include information regarding the prohibition of discrimination, harassment, intimidation, and bullying; unlawful student fees; local control and accountability plan (LCAP) requirements; and requirements related to the educational rights of foster youth, homeless students, former juvenile court school students, and children of military families. (Education Code 262.3, 48853, 48853.5, 49010-49013, 49069.5, 51225.1, 51225.2, 52075; 5 CCR 4622)

- (cf. 0420 - School Plans/Site Councils)*
- (cf. 0460 - Local Control and Accountability Plan)*
- (cf. 1220 - Citizen Advisory Committees)*
- (cf. 3260 - Fees and Charges)*
- (cf. 4112.9/4212.9/4312.9 - Employee Notifications)*
- (cf. 5145.6 - Parental Notifications)*
- (cf. 6173 - Education for Homeless Children)*
- (cf. 6173.1 - Education for Foster Youth)*
- (cf. 6173.2 - Education of Children of Military Families)*
- (cf. 6173.3 - Education for Juvenile Court School Students)*

The notice shall:

- 1. Identify the person(s), position(s), or unit(s) responsible for receiving complaints*
- 2. Advise the complainant of any civil law remedies that may be available to him/her under state or federal antidiscrimination laws, if applicable*
- 3. Advise the complainant of the appeal process, including, if applicable, the complainant's right to take a complaint directly to the California Department of Education (CDE) or to pursue remedies before civil courts or other public agencies, such as the U.S. Department of Education's Office for Civil Rights (OCR) in cases involving unlawful discrimination (such as discriminatory harassment, intimidation, or bullying).*
- 4. Include statements that:*
 - a. The district has the primary responsibility to ensure compliance with applicable state and federal laws and regulations governing educational programs.*

UNIFORM COMPLAINT PROCEDURES (continued)

- b. *The complaint review shall be completed within 60 calendar days from the date of receipt of the complaint unless the complainant agrees in writing to an extension of the timeline.*
- c. *A complaint alleging retaliation or unlawful discrimination (such as discriminatory harassment, intimidation, or bullying) must be filed not later than six months from the date it occurred, or six months from the date the complainant first obtained knowledge of the facts of the alleged unlawful discrimination. The time for filing may be extended for up to 90 days by the Superintendent or designee for good cause upon written request by the complainant setting forth the reasons for the extension.*
- d. *Complaints should be filed in writing and signed by the complainant. If a complainant is unable to put his/her complaint in writing, for example, due to conditions such as a disability or illiteracy, district staff shall assist him/her in the filing of the complaint.*
- e. *If a complaint is not filed in writing but the district receives notice of any allegation that is subject to the UCP, the district shall take affirmative steps to investigate and address the allegations, in a manner appropriate to the particular circumstances.*

If the allegation involves retaliation or unlawful discrimination (such as discriminatory harassment, intimidation, or bullying) and the investigation confirms that discrimination has occurred, the district will take steps to prevent recurrence of discrimination and correct its discriminatory effects on the complainant, and on others, if appropriate.
- f. *A student enrolled in a public school shall not be required to pay a fee for his/her participation in an educational activity that constitutes an integral fundamental part of the district's educational program, including curricular and extracurricular activities.*
- g. *The Board is required to adopt and annually update the LCAP in a manner that includes meaningful engagement of parents/guardians, students, and other stakeholders in the development and/or review of the LCAP.*
- h. *A foster youth shall receive information about educational rights related to his/her educational placement, enrollment in and checkout from school, as well as the responsibilities of the district liaison for foster youth to ensure and facilitate these requirements and to assist the student in ensuring proper transfer of his/her credits, records, and grades when he/she transfers between schools or between the district and another district.*

UNIFORM COMPLAINT PROCEDURES (continued)

- i. *A foster youth, homeless student, former juvenile court school student, or child of a military family who transfers into a district high school or between district high schools as applicable shall be notified of the district's responsibility to:*
 - (1) *Accept any coursework or part of the coursework that the student has satisfactorily completed in another public school, juvenile court school, or a nonpublic, nonsectarian school or agency, and to issue full or partial credit for the coursework completed*
 - (2) *Not require the student to retake any course or a portion of a course which he/she has satisfactorily completed in another public school, juvenile court school, or a nonpublic, nonsectarian school or agency*
 - (3) *If the student has completed his/her second year of high school before the transfer, provide the student information about district-adopted coursework and Board-imposed graduation requirements from which he/she may be exempted pursuant to Education Code 51225.1*
- j. *The complainant has a right to appeal the district's decision to CDE by filing a written appeal within 15 calendar days of receiving the district's decision.*

In any complaint alleging unlawful discrimination (such as discriminatory harassment, intimidation, or bullying), the respondent also shall have the right to file an appeal with CDE in the same manner as the complainant, if he/she is dissatisfied with the district's decision.
- k. *The appeal to CDE must include a copy of the complaint filed with the district and a copy of the district's decision.*
- l. *Copies of the district's UCP are available free of charge.*

The annual notification, complete contact information of the compliance officer(s), and information related to Title IX as required pursuant to Education Code 221.61 shall be posted on the district web site and may be provided through district-supported social media, if available.

*(cf. 1113 - District and School Web Sites)
(cf. 1114 - District-Sponsored Social Media)*

The Superintendent or designee shall ensure that all students and parents/guardians, including students and parents/guardians with limited English proficiency, have access to the relevant information provided in the district's policy, regulation, forms, and notices concerning the UCP.

UNIFORM COMPLAINT PROCEDURES (continued)

If 15 percent or more of students enrolled in a particular district school speak a single primary language other than English, the district's policy, regulation, forms, and notices concerning the UCP shall be translated into that language, in accordance with Education Code 234.1 and 48985. In all other instances, the district shall ensure meaningful access to all relevant UCP information for parents/guardians with limited English proficiency.

District Responsibilities

All UCP-related complaints shall be investigated and resolved within 60 calendar days of the district's receipt of the complaint unless the complainant agrees in writing to an extension of the timeline. (5 CCR 4631)

For complaints alleging unlawful discrimination (such as discriminatory harassment, intimidation, or bullying), the district shall inform the respondent when the complainant agrees to an extension of the timeline for investigating and resolving the complaint.

The compliance officer shall maintain a record of each complaint and subsequent related actions, including steps taken during the investigation and all information required for compliance with 5 CCR 4631 and 4633.

All parties involved in the allegations shall be notified when a complaint is filed and when a decision or ruling is made. However, the compliance officer shall keep all complaints or allegations of retaliation or unlawful discrimination (such as discriminatory harassment, intimidation, or bullying) confidential except when disclosure is necessary to carry out the investigation, take subsequent corrective action, conduct ongoing monitoring, or maintain the integrity of the process. (5 CCR 4630, 4964)

All complainants shall be protected from retaliation.

Filing of Complaints

The complaint shall be presented to the compliance officer who shall maintain a log of complaints received, providing each with a code number and a date stamp.

All complaints shall be filed in writing and signed by the complainant. If a complainant is unable to put a complaint in writing due to conditions such as a disability or illiteracy, district staff shall assist him/her in the filing of the complaint. (5 CCR 4600)

Complaints shall also be filed in accordance with the following rules, as applicable:

- 1. A complaint alleging district violation of applicable state or federal law or regulations governing the programs specified in the accompanying Board policy*

UNIFORM COMPLAINT PROCEDURES (continued)

- (item #1 of the section "Complaints Subject to the UCP") may be filed by any individual, public agency, or organization. (5 CCR 4630)
2. Any complaint alleging noncompliance with law regarding the prohibition against requiring students to pay student fees, deposits, and charges or any requirement related to the LCAP may be filed anonymously if the complaint provides evidence, or information leading to evidence, to support an allegation of noncompliance. A complaint about a violation of the prohibition against the charging of unlawful student fees may be filed with the principal of the school or with the Superintendent or designee. However, any such complaint shall be filed no later than one year from the date the alleged violation occurred. (Education Code 49013, 52075; 5 CCR 4630)
 3. A complaint alleging unlawful discrimination (such as discriminatory harassment, intimidation, or bullying) may be filed only by a person who alleges that he/she personally suffered the unlawful discrimination or by a person who believes that an individual or any specific class of individuals has been subjected to it. The complaint shall be initiated no later than six months from the date when the alleged unlawful discrimination occurred, or six months from the date when the complainant first obtained knowledge of the facts of the alleged unlawful discrimination. The time for filing may be extended for up to 90 days by the Superintendent or designee for good cause upon written request by the complainant setting forth the reasons for the extension. (5 CCR 4630)
 4. When a complaint alleging unlawful discrimination (such as discriminatory harassment, intimidation, or bullying) is filed anonymously, the compliance officer shall pursue an investigation or other response as appropriate, depending on the specificity and reliability of the information provided and the seriousness of the allegation.
 5. When the complainant of unlawful discrimination (such as discriminatory harassment, intimidation, or bullying) or the alleged victim, when he/she is not the complainant, requests confidentiality, the compliance officer shall inform him/her that the request may limit the district's ability to investigate the conduct or take other necessary action. When honoring a request for confidentiality, the district shall nevertheless take all reasonable steps to investigate and resolve/respond to the complaint consistent with the request.

Mediation

Within three business days after the compliance officer receives the complaint, he/she may informally discuss with all the parties the possibility of using mediation. Mediation shall be offered to resolve complaints that involve more than one student and no adult. However,

UNIFORM COMPLAINT PROCEDURES (continued)

mediation shall not be offered or used to resolve any complaint involving an allegation of sexual assault or where there is a reasonable risk that a party to the mediation would feel compelled to participate. If the parties agree to mediation, the compliance officer shall make all arrangements for this process.

Before initiating the mediation of a complaint alleging retaliation or unlawful discrimination (such as discriminatory harassment, intimidation, or bullying), the compliance officer shall ensure that all parties agree to make the mediator a party to relevant confidential information. The compliance officer shall also notify all parties of the right to end the informal process at any time.

If the mediation process does not resolve the problem within the parameters of law, the compliance officer shall proceed with his/her investigation of the complaint. The use of mediation shall not extend the district's timelines for investigating and resolving the complaint unless the complainant agrees in writing to such an extension of time. If mediation is successful and the complaint is withdrawn, then the district shall take only the actions agreed upon through the mediation. If mediation is unsuccessful, the district shall then continue with subsequent steps specified in this administrative regulation.

Investigation of Complaint

Within 10 business days after the compliance officer receives the complaint, the compliance officer shall begin an investigation into the complaint.

Within one business day of initiating the investigation, the compliance officer shall provide the complainant and/or his/her representative with the opportunity to present the information contained in the complaint to the compliance officer and shall notify the complainant and/or his/her representative of the opportunity to present the compliance officer with any evidence, or information leading to evidence, to support the allegations in the complaint. Such evidence or information may be presented at any time during the investigation.

In conducting the investigation, the compliance officer shall collect all available documents and review all available records, notes, or statements related to the complaint, including any additional evidence or information received from the parties during the course of the investigation. He/she shall individually interview all available witnesses with information pertinent to the complaint, and may visit any reasonably accessible location where the relevant actions are alleged to have taken place. At appropriate intervals, the compliance officer shall inform both parties of the status of the investigation.

To investigate a complaint alleging retaliation or unlawful discrimination (such as discriminatory harassment, intimidation, or bullying), the compliance officer shall interview the alleged victim(s), any alleged offenders, and other relevant witnesses privately, separately, and in a confidential manner. As necessary, additional staff or legal counsel may conduct or support the investigation.

UNIFORM COMPLAINT PROCEDURES (continued)

A complainant's refusal to provide the district's investigator with documents or other evidence related to the allegations in the complaint, failure or refusal to cooperate in the investigation, or engagement in any other obstruction of the investigation may result in the dismissal of the complaint because of a lack of evidence to support the allegation. Similarly, a respondent's refusal to provide the district's investigator with documents or other evidence related to the allegations in the complaint, failure or refusal to cooperate in the investigation, or engagement in any other obstruction of the investigation may result in a finding, based on evidence collected, that a violation has occurred and in the imposition of a remedy in favor of the complainant. (5 CCR 4631)

In accordance with law, the district shall provide the investigator with access to records and other information related to the allegation in the complaint and shall not in any way obstruct the investigation. Failure or refusal of the district to cooperate in the investigation may result in a finding based on evidence collected that a violation has occurred and in the imposition of a remedy in favor of the complainant. (5 CCR 4631)

The compliance officer shall apply a "preponderance of the evidence" standard in determining the veracity of the factual allegations in a complaint. This standard is met if the allegation is more likely to be true than not.

Report of Findings

Unless extended by written agreement with the complainant, a final decision shall be sent to the complainant within 60 calendar days of the district's receipt of the complaint.

Within 30 calendar days of receiving the complaint, the compliance officer shall prepare and send to the complainant a written report, as described in the section "Final Written Decision" below. If the complainant is dissatisfied with the compliance officer's decision, he/she may, within five business days, file his/her complaint in writing with the Board.

The Board may consider the matter at its next regular Board meeting or at a special Board meeting convened in order to meet the 60-day time limit within which the complaint must be answered. When required by law, the matter shall be considered in closed session. The Board may decide not to hear the complaint, in which case the compliance officer's decision shall be final.

If the Board hears the complaint, the compliance officer shall send the Board's decision to the complainant within 60 calendar days of the district's initial receipt of the complaint or within the time period that has been specified in a written agreement with the complainant. (5 CCR 4631)

In resolving any complaint alleging unlawful discrimination (such as discriminatory harassment, intimidation, and bullying), the respondent also shall be sent the district's

UNIFORM COMPLAINT PROCEDURES *(continued)*

decision and, in the same manner as the complainant, may file a complaint with the Board if dissatisfied with the decision.

Final Written Decision

The district's decision on how it will resolve the complaint shall be in writing and shall be sent to the complainant and respondent. (5 CCR 4631)

In consultation with district legal counsel, information about the relevant part of a decision may be communicated to a victim who is not the complainant and to other parties who may be involved in implementing the decision or are affected by the complaint, as long as the privacy of the parties is protected. In a complaint alleging unlawful discrimination (such as discriminatory harassment, intimidation, and bullying), notice of the district's decision to the alleged victim shall include information about any sanction to be imposed upon the respondent that relates directly to the alleged victim.

If the complaint involves a limited-English-proficient student or parent/guardian and the student involved attends a school at which 15 percent or more of the students speak a single primary language other than English, then the decision shall also be translated into that language. In all other instances, the district shall ensure meaningful access to all relevant information for parents/guardians with limited English proficiency.

For all complaints, the decision shall include: (5 CCR 4631)

1. *The findings of fact based on the evidence gathered. In reaching a factual determination, the following factors may be taken into account:*
 - a. *Statements made by any witnesses*
 - b. *The relative credibility of the individuals involved*
 - c. *How the complaining individual reacted to the incident*
 - d. *Any documentary or other evidence relating to the alleged conduct*
 - e. *Past instances of similar conduct by any alleged offenders*
 - f. *Past false allegations made by the complainant*
2. *The conclusion(s) of law*
3. *Disposition of the complaint*

UNIFORM COMPLAINT PROCEDURES (continued)

4. *Rationale for such disposition*

For complaints of retaliation or unlawful discrimination (such as discriminatory harassment, intimidation, or bullying), the disposition of the complaint shall include a determination for each allegation as to whether retaliation or unlawful discrimination has occurred.

The determination of whether a hostile environment exists may involve consideration of the following:

- a. *The manner in which the misconduct affected one or more students' education*
 - b. *The type, frequency, and duration of the misconduct*
 - c. *The relationship between the alleged victim(s) and offender(s)*
 - d. *The number of persons engaged in the conduct and at whom the conduct was directed*
 - e. *The size of the school, location of the incidents, and context in which they occurred*
 - f. *Other incidents at the school involving different individuals*
5. *Corrective action(s), including any actions that have been taken or will be taken to address the allegations in the complaint and including, with respect to a student fees complaint, a remedy that comports with Education Code 49013 and 5 CCR 4600*

For complaints of unlawful discrimination (such as discriminatory harassment, intimidation, or bullying), the decision may, as required by law, include:

- a. *The corrective actions imposed on the respondent*
- b. *Individual remedies offered or provided to the complainant or another person who was the subject of the complaint, but this information should not be shared with the respondent.*
- c. *Systemic measures the school has taken to eliminate a hostile environment and prevent recurrence*

UNIFORM COMPLAINT PROCEDURES (continued)

6. *Notice of the complainant's and respondent's right to appeal the district's decision to CDE within 15 calendar days, and procedures to be followed for initiating such an appeal*

The decision may also include follow-up procedures to prevent recurrence or retaliation and for reporting any subsequent problems.

For complaints alleging unlawful discrimination based on state law (such as discriminatory harassment, intimidation, and bullying), the decision shall also include a notice to the complainant that:

1. *He/she may pursue available civil law remedies outside of the district's complaint procedures, including seeking assistance from mediation centers or public/private interest attorneys, 60 calendar days after the filing of an appeal with CDE. (Education Code 262.3)*
2. *The 60 days moratorium does not apply to complaints seeking injunctive relief in state courts or to discrimination complaints based on federal law. (Education Code 262.3)*
3. *Complaints alleging discrimination based on race, color, national origin, sex, gender, disability, or age may also be filed with the U.S. Department of Education, Office for Civil Rights at www.ed.gov/ocr within 180 days of the alleged discrimination.*

Corrective Actions

When a complaint is found to have merit, the compliance officer shall adopt any appropriate corrective action permitted by law. Appropriate corrective actions that focus on the larger school or district environment may include, but are not limited to, actions to reinforce district policies; training for faculty, staff, and students; updates to school policies; or school climate surveys.

For complaints involving retaliation or unlawful discrimination (such as discriminatory harassment, intimidation, or bullying), appropriate remedies that may be offered to the victim but not communicated to the respondent may include, but are not limited to, the following:

1. *Counseling*
2. *Academic support*

UNIFORM COMPLAINT PROCEDURES *(continued)*

3. *Health services*
4. *Assignment of an escort to allow the victim to move safely about campus*
5. *Information regarding available resources and how to report similar incidents or retaliation*
6. *Separation of the victim from any other individuals involved, provided the separation does not penalize the victim*
7. *Restorative justice*
8. *Follow-up inquiries to ensure that the conduct has stopped and there has been no retaliation*
9. *Determination of whether any past actions of the victim that resulted in discipline were related to the treatment the victim received and described in the complaint*

For complaints involving retaliation or unlawful discrimination (such as discriminatory harassment, intimidation, or bullying), appropriate corrective actions that focus on a student offender may include, but are not limited to, the following:

1. *Transfer from a class or school as permitted by law*
2. *Parent/guardian conference*
3. *Education regarding the impact of the conduct on others*
4. *Positive behavior support*
5. *Referral to a student success team*
6. *Denial of participation in extracurricular or co-curricular activities or other privileges as permitted by law*
7. *Disciplinary action, such as suspension or expulsion, as permitted by law*

When an employee is found to have committed retaliation or unlawful discrimination (such as discriminatory harassment, intimidation, or bullying), the district shall take appropriate disciplinary action, up to and including dismissal, in accordance with applicable law and collective bargaining agreement.

UNIFORM COMPLAINT PROCEDURES (continued)

The district may also consider training and other interventions for the larger school community to ensure that students, staff, and parents/guardians understand the types of behavior that constitute unlawful discrimination (such as discriminatory harassment, intimidation, or bullying), that the district does not tolerate it, and how to report and respond to it.

When a complaint is found to have merit, an appropriate remedy shall be provided to the complainant or other affected person. If a complaint alleging noncompliance with the laws regarding student fees, deposits, and other charges, physical education instructional minutes for students in elementary schools, or any requirement related to the LCAP is found to have merit, the district shall provide a remedy to all affected students and parents/guardians subject to procedures established by regulation of the State Board of Education. (Education Code 49013, 51223, 52075)

For complaints alleging noncompliance with the laws regarding student fees, the district shall attempt in good faith, by engaging in reasonable efforts, to identify and fully reimburse all affected students and parents/guardians who paid the unlawful student fees within one year prior to the filing of the complaint. (Education Code 49013; 5 CCR 4600)

Appeals to the California Department of Education

Any complainant who is dissatisfied with the district's final written decision of a complaint regarding any specified federal or state educational program subject to the UCP may file an appeal in writing with CDE within 15 calendar days of receiving the district's decision. (Education Code 222, 48853, 48853.5, 49013, 49069.5, 51223, 51225.1, 51225.2, 51228.3, 52075; 5 CCR 4632)

When a respondent in any complaint alleging unlawful discrimination (such as discriminatory harassment, intimidation, and bullying) is dissatisfied with the district's final written decision, he/she, in the same manner as the complainant, may file an appeal with CDE.

The complainant or respondent shall specify the basis for the appeal of the decision and how the facts of the district's decision are incorrect and/or the law has been misapplied. The appeal shall be sent to CDE with a copy of the original locally filed complaint and a copy of the district's decision in that complaint. (5 CCR 4632)

Upon notification by the CDE that the complainant has appealed the district's decision, the Superintendent or designee shall forward the following documents to the CDE: (5 CCR 4633)

1. A copy of the original complaint
2. A copy of the written decision

UNIFORM COMPLAINT PROCEDURES (continued)

3. A summary of the nature and extent of the investigation conducted by the district, if not covered by the decision
4. A copy of the investigation file including, but not limited to, all notes, interviews, and documents submitted by the parties and gathered by the investigator
5. A report of any action taken to resolve the complaint
6. A copy of the district's uniform complaint procedures
7. Other relevant information requested by the CDE

~~Nothing in this document shall prohibit anyone involved in the complaint from utilizing alternative methods to resolve the allegations, such as mediation. Nor are we prohibited from resolving complaints prior to the formal filing of a written complaint. Mediation is a problem solving activity whereby a third party assists the parties to the dispute in resolving the complaint.~~

~~State and Federal Laws cited:~~

- ~~1. 34 Code of Federal Regulations [CFR] §§ 300.510-511~~
- ~~2. California Code of Regulations [CCR] Title 5 §§ 4600-4687~~
- ~~3. California Code of Regulations [CCR] Title 5 § 4610(b)~~
- ~~4. California Code of Regulations [CCR] Title 5 § 4622~~
- ~~5. California Code of Regulations [CCR] Title 5 §§ 4630-4631~~
- ~~6. California Education Code [EC] §§ 200, 220, 262.3~~
- ~~7. California Education Code [EC] § 262.3(d)~~
- ~~8. California Education Code [EC] § 35186~~
- ~~9. Government Code [GC] §§ 11135, 11138~~

Regulation
approved: October 19, 2011

Revised: January 16, 2013; June 26, 2013; September 4, 2013; August 24, 2016;
January 18, 2017; *May 16, 2018*

OXNARD SCHOOL DISTRICT
Oxnard, California

OSD BOARD AGENDA ITEM

Name of Contributor: Robin I. Freeman

Date of Meeting: 5/2/18

- A. Preliminary _____
Study Session _____
Report _____
- B. Hearing: _____
- C. Consent Agenda _____

Agreement Category:

- ___ Academic
- ___ Enrichment
- ___ Special Education
- ___ Support Services
- ___ Personnel
- ___ Legal
- ___ Facilities

- D. Action Items _____
- E. Approval of Minutes _____
- F. Board Policies 1st Reading X 2nd Reading _____

STUDENT ASSESSMENT – Revision to BP 6162.5 (Freeman)

Language was added and deleted to BP 6162.5 to align with the district’s goals for Student Assessment. The added language is indicated by *italicized* font on the attached. The deleted language is indicated by *strikethrough* on the attached.

FISCAL IMPACT:

None

RECOMMENDATION:

It is the recommendation of the Assistant Superintendent Educational Services that the Board of Trustees approve the revisions to BP 6162.5 as outlined above.

ADDITIONAL MATERIAL:

BP 6162.5 (3 pages)

STUDENT ASSESSMENT

The Board of Trustees recognizes that student assessments are an important instructional and accountability tool. ~~Assessment data shall be used to help determine individual students' progress, mastery of academic standards, appropriate placement in district programs, and/or eligibility for graduation. In addition, program effectiveness and staff evaluations shall, as appropriate, be based in part on indicators of student achievement. To obtain the most accurate evaluation of student performance, the district shall use a variety of measures, including district, state, and/or national assessments.~~

(cf. 6162.51 – State Academic Achievement Tests)

Assessment data shall be used to help determine individual students' progress, mastery of academic standards, and appropriate placement in district programs. In addition, summary data on student assessment results shall be used by the district to identify and review student achievement goals in the district's local control and accountability plan, and evaluate district educational programs in order to identify needed improvements.

(cf. 0460-Local Control and Accountability Plan)

(cf. 0500 - Accountability)

(cf. 2140 – Evaluation of the Superintendent)

(cf. 4115 - Evaluation/Supervision)

(cf. 4315 – Evaluation/Supervision)

(cf. 5121 – Grades/Evaluation of Student Achievement)

(cf. 5123 - Promotion/Acceleration/Retention)

(cf. 6011 - Academic Standards)

(cf. 6142.7 – Physical Education and Activity)

(cf. 6190 - Evaluation of the Instructional Program)

~~To obtain the most accurate evaluation of student performance, the district shall use a variety of measures, including district, state, and/or national assessments. As appropriate, assessment results shall be disaggregated by student subgroup, classroom, grade level, or school site to allow for critical analysis of student needs.~~

(cf. 5121 – Grades/Evaluation of Student Achievement)

(cf. 6142.7 – Physical Education and Activity)

(cf. 6162.51 – Standardized Testing and Reporting Program)

(cf. 6162.52 – High School Exit Examination)

In selecting or developing a district assessment, the Superintendent or designee shall examine evidence of its reliability, its validity for the intended purpose and for various student populations, and the extent to which it corresponds to the material that is being taught.

The Superintendent or designee shall ensure that assessments are administered in accordance with law and the test publisher's directions and that test administration procedures are fair and equitable for all students.

(cf. 0410 - Nondiscrimination in District Programs and Activities)

(cf. 6162.54 - Test Integrity/Test Preparation)

STUDENT ASSESSMENT (continued)

As appropriate, assessment results shall be disaggregated by student subgroup, classroom, grade level, and/or school site to allow for critical analysis of student needs.

The Superintendent or designee shall provide professional development to assist teachers and Paraeducators in interpreting and using assessment data to improve student performance and the instructional program.

(cf. 4131 - Staff Development)

(cf. 4331 – Staff Development)

(~~cf. 4222 – Teacher Aides/Paraeducators~~)

When districtwide and school-level results of student assessments are published by the state, the Superintendent or designee may provide supplementary information to assist parents/guardians and the local community in ~~interpreting test results and evaluating school performance~~. *understanding test results.*

(cf. 0510 - School Accountability Report Card)

Interim and Formative Assessments

State interim and formative assessments may be used in combination with other sources of information to gain timely feedback about student progress in an effort to continually adjust instruction to improve learning. Results from interim and formative assessments shall not be used for any high-stakes purpose, including, but not limited to, teacher or other school staff evaluation, accountability, student grade promotion or retention, course or class placement, identification for gifted or talented education, reclassification of English Learners, or identification as an individual with exceptional needs. (Education Code 60642.6, 60642.7)

(cf. 5123 – Promotion/Acceleration/Retention)

(cf. 6164.4 – Identification and Evaluation of Individuals for Special Education)

(cf. 6172 – Gifted and Talented Student Program)

(cf. 6174 – Education for English Learners)

The Superintendent or designee shall ensure that teachers who administer interim and formative assessments have access to all functions and information designed for teacher use related to such assessments and student performance on the assessments. (Education Code 60642.6)

Legal Reference:

EDUCATION CODE

313 Assessment of English language development

10600-10610 California Education Information System

44660-44665 Evaluation and assessment of performance of certificated employees (Stull Act)

51041 Evaluation of educational program

~~51450-51455 Golden State Seal Merit Diploma~~

60600-60649 Assessment of academic achievement, especially:

STUDENT ASSESSMENT (continued)

60640-60649 *Standardized Testing and Reporting Program*
60800 *Physical fitness testing*
60810-60812 *Assessment of English language development*
~~60850-60859 *High school exit examination*~~
60900 *California Longitudinal Pupil Achievement Data System*
CODE OF REGULATIONS, TITLE 5
850-870 *Standardized Testing and Reporting program*
~~1200-1225 *High School Exit Examination*~~
UNITED STATES CODE, TITLE 20
9622 *National Assessment of Educational Progress*

Management Resources:

~~CALIFORNIA DEPARTMENT OF EDUCATION PUBLICATIONS
Key Elements of Testing, 2004
U.S. DEPARTMENT OF EDUCATION PUBLICATIONS
Teachers' Use of Student Data Systems to Improve Instruction, 2007~~
WEB SITES

CSBA: <http://www.csba.org>

California Department of Education, Testing and Accountability: <http://www.cde.ca.gov/ta>

Educational Testing Service: <http://www.ets.org>

U.S. Department of Education: <http://www.ed.gov>

Policy
adopted: November 16, 2011
Revised: May 16, 2018

OXNARD SCHOOL DISTRICT
Oxnard, California



OXNARD SCHOOL DISTRICT

1051 South “A” Street • Oxnard, California 93030 • 805/385-1501

SCHEDULE OF BOARD MEETINGS JANUARY – DECEMBER 2018

BOARD MEETINGS WILL BE HELD ON THE FOLLOWING DATES (UNLESS OTHERWISE INDICATED) AT THE DISTRICT OFFICE BOARD ROOM, 1051 SOUTH ‘A’ STREET, STARTING AT 7:00 PM

| | | |
|-----------|----|---|
| January | 17 | Regular Board Meeting (Note: only ONE meeting in January) |
| February | 7 | Regular Board Meeting |
| | 21 | Regular Board Meeting |
| March | 7 | Regular Board Meeting |
| | 21 | Regular Board Meeting |
| April | 18 | Regular Board Meeting (Note: only ONE meeting in April) |
| May | 2 | Regular Board Meeting |
| | 16 | Regular Board Meeting |
| June | 6 | Regular Board Meeting |
| | 20 | Regular Board Meeting |
| July | | District Dark – No meeting in July |
| August | 8 | Regular Board Meeting |
| | 22 | Regular Board Meeting |
| September | 5 | Regular Board Meeting |
| | 19 | Regular Board Meeting |
| October | 10 | Regular Board Meeting |
| | 24 | Regular Board Meeting |
| November | 14 | Regular Board Meeting (Note: only ONE meeting in November) |
| December | 12 | Regular Board Meeting – Organizational Meeting of the Board (Note: only ONE meeting in December) |

The meeting schedule shown above is subject to change at any time.

NOTE: Changes are indicated in italics/bold.

Spring Break: March 26 – April 6, 2018
First Day of School: August 16, 2018

Board Approved: 12-6-17

Mission: “Ensure a culturally diverse education for each student in a safe, healthy and supportive environment that prepares students for college and career opportunities.”