

OXNARD SCHOOL DISTRICT

1051 South "A" Street • Oxnard, California 93030 • 805/385-1501

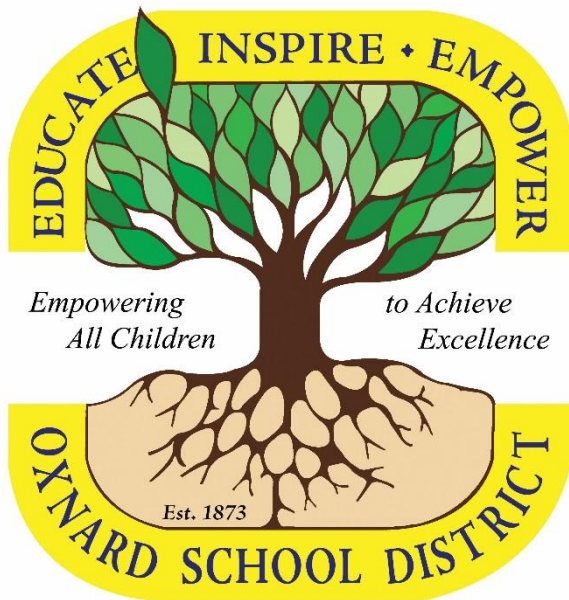

BOARD OF TRUSTEES

Mr. Ernest "Mo" Morrison, President
Mrs. Debra M. Cordes, Clerk
Mr. Denis O'Leary, Member
Mrs. Veronica Robles-Solis, Member
Ms. Monica Madrigal Lopez, Member

ADMINISTRATION

Dr. Cesar Morales
District Superintendent
Ms. Lisa Cline
Deputy Superintendent,
Business & Fiscal Services
Dr. Jesus Vaca
Assistant Superintendent,
Human Resources & Support Services
Ms. Robin I. Freeman
Assistant Superintendent,
Educational Services

AGENDA #12
REGULAR BOARD MEETING
Wednesday, March 1, 2017
5:00 p.m.
Closed Session To Follow
7:00 PM - Regular Board Meeting

***NOTE:** In accordance with requirements of the Americans with Disabilities Act and related federal regulations, individuals who require special accommodation, including but not limited to an American Sign Language interpreter, accessible seating or documentation in accessible formats, should contact the Superintendent's office at least two days before the meeting date.

Persons wishing to address the Board of Trustees on any agenda item may do so by completing a "**Speaker Request Form**" and submitting the form to the **Asst. Supt. of Human Resources**. The Speaker should indicate on the card whether they wish to speak during Public Comment or when a specific agenda item is considered.

Note: No new items will be considered after 10:00 p.m. in accordance with Board Bylaws, BB 9323 – Meeting Conduct

www.oxnardsd.org

OPIE TV – Channel 20 &
Verizon FIOS - Channel 37



Vision:

Empowering All Children to Achieve Excellence

Mission:

Ensure a culturally diverse education for each student in a safe, healthy and supportive environment that prepares students for college and career opportunities.



Visión:

Capacitar a cada alumno para que logre la excelencia académica

Misión:

Asegurar una educación culturalmente diversa para todo el alumnado en un ambiente seguro, saludable y propicio que les prepare para la Universidad y el acceso a oportunidades para desarrollar una carrera profesional.

**Section A
PRELIMINARY**

A.1 Call to Order and Roll Call **5:00 PM**

The President of the Board will call the meeting to order. A roll call of the Board will be conducted.

A.2 Pledge of Allegiance to the Flag

Ms. Anne Jenks, Principal at McKinna School of Multimedia, will introduce Virgie Cruz Solis, 5th grader in Mr. Richard Raddas’ class, who will lead the audience in the Pledge of Allegiance.

A.3 District’s Vision and Mission Statements

The District’s Vision and Mission Statements will be read by Fernando Zaragoza, 5th grader in Ms. Nancy Buenrostro’s class in English and in Spanish.

A.4 Presentation by McKinna School of Multimedia

Ms. Anne Jenks will provide a short presentation to the Board regarding McKinna School of Multimedia. Following the presentation President Morrison will present a token of appreciation to the students that participated in the Board Meeting.

A.5 Recognition of Oxnard School District’s Million Word Readers (Freeman/Curtis)

The Board of Trustees will recognize Oxnard School District Students who have read One Million Words.

A.6 Adoption of Agenda (Superintendent)

Moved:
Seconded:
Vote:

ROLL CALL VOTE:

Madrigal Lopez __, Robles-Solis __, O’Leary __, Cordes __, Morrison __

A.7 Closed Session – Public Participation/Comment (Limit three minutes per person per topic)

Persons wishing to address the Board of Trustees on any agenda item identified in the Closed Session agenda may do so by completing a “Speaker Request Form” and submitting the form to the Assistant Superintendent of Human Resources and Support Services. Public Comment shall be limited to fifteen (15) minutes per subject with a maximum of three (3) minutes per speaker.

The Board will now convene in closed session to consider the items listed under Closed Session.

A.8 Closed Session

1. Pursuant to Section 54956.9 of *Government Code*:
 - Conference with Legal Counsel – Anticipated Litigation: 1 case
 - Conference with Legal Counsel – Existing Litigations: 2 cases

2. REMOVAL/SUSPENSION/EXPULSION OF A STUDENT (*Education Code 48912; 20 U.S.C. Section 1232g*)
 - Case No. 16-04 (Action Item)
 - Case No. 16-07

Note: No new items will be considered after 10:00 p.m. in accordance with Board Bylaws, BB 9323 – Meeting Conduct

**Section A
PRELIMINARY**
(continued)

A.8 Closed Session (continued)

- 3. Pursuant to Sections 54957.6 and 3549.1 of the *Government Code*:
 - Conference with Labor Negotiator:
Agency Negotiators: OSD Assistant Superintendent, Human Resources & Support Services, and Garcia Hernández & Sawhney, LLP
Association(s): OEA, OSSA, CSEA;
and All Unrepresented Personnel – Administrators, Classified Management, Confidential

- 4. Pursuant to Section 54956.8 of the *Government Code*:
 - Conference with Real Property Negotiators (for acquisition of new school site):
Property: Parcel located Teal Club Road, North of Teal Club Road, South of Doris Avenue

Agency Negotiators: Superintendent/Deputy Superintendent, Business & Fiscal Services/ Garcia Hernandez & Sawhney, LLP/ Caldwell Flores Winters Inc.

Negotiating Parties: Dennis Hardgrave on behalf of the property owners
Under Negotiations: Instruction to agency negotiator on price and terms.

- 5. Pursuant to Section 54957 of the *Government Code* and Section 44943 of the *Education Code* the Board will consider personnel matters, including:
 - Public Employee(s) Discipline/Dismissal/Release
 - Public Employee(s) Reassignment/Appointment:
 - Public Employee(s) Non Re-Elects
 - Public Employee Evaluation(s): Principals

A.9 Reconvene to Open Session **7:00 PM**

A.10 Report Out of Closed Session

The Board will report on any action taken in closed session or take action on any item considered in closed session, including expulsion of students.

REMOVAL/SUSPENSION/EXPULSION OF A STUDENT

(Education Code 48912; 20 U.S.C. Section 1232g)

Case No. 16-04 (Action Item)

Motion: _____, Second: _____

Roll Call Vote:

Madrigal Lopez __, O’Leary __, Morrison __ Cordes __, Robles-Solis __

REMOVAL/SUSPENSION/EXPULSION OF A STUDENT

(Education Code 48912; 20 U.S.C. Section 1232g)

Case No. 16-07 (Action Item)

Motion: _____, Second: _____

Roll Call Vote:

Madrigal Lopez __, O’Leary __, Morrison __ Cordes __, Robles-Solis __

Note: No new items will be considered after 10:00 p.m. in accordance with Board Bylaws, BB 9323 – Meeting Conduct

Section A
PRELIMINARY
(continued)

A.11 Recognition of Oxnard School District's Million Word Readers (Freeman/Curtis)

The Board of Trustees will recognize Oxnard School District Students who have read One Million Words.

A.12 Measure R Bond Oversight Committee's Annual Report (Cline)

The Board of Trustees will receive a presentation on the Bond Oversight Committee's fourth annual report, as a requirement of Proposition 39.

A.13 Cal200 Settlement Agreement Report (Freeman)

The Board of Trustees will receive a report on the Oxnard School District's compliance with the Cal200 settlement.

**Note: No new items will be considered after 10:00 p.m. in accordance with
Board Bylaws, BB 9323 – Meeting Conduct**

Section B
PUBLIC COMMENT/HEARINGS

B.1 Public Comment (3 minutes per speaker)

Members of the public may address the Board on any matter within the Board's jurisdiction at this time or at the time that a specific agenda item is being considered. Comments should be limited to three (3) minutes. Please know this meeting is being video-recorded and televised. The Board particularly invites comments from parents of students in the District.

B.1 Comentarios del Público (3 minutos para cada ponente)

Los miembros del público podrán dirigirse a la Mesa Directiva sobre cualquier asunto que corresponda a la jurisdicción de la Mesa Directiva en este periodo o cuando este punto figure en el orden del día y sea analizado. Los comentarios deben limitarse a tres (3) minutos. Tenga presente que esta reunión está siendo grabada y televisada. La Mesa Directiva invita en particular a los padres y alumnos del distrito a que presenten sus comentarios.

**Note: No new items will be considered after 10:00 p.m. in accordance with
Board Bylaws, BB 9323 – Meeting Conduct**

Section C CONSENT AGENDA

(All Matters Specified as Consent Agenda are considered by the Board to be routine and will be acted upon in one motion. There will be no discussion of these items prior to the time the Board votes on the motion unless members of the Board request specific items be discussed and/or removed from the Consent Agenda.)

Notes:
Moved:
Seconded:

ROLL CALL VOTE:

Madrigal Lopez __, **Robles-Solis** __, **O’Leary** __, **Cordes** __, **Morrison** __

C.1 Agreements

It is recommended that the Board approve the following agreements: Dept/School

Academic:

- #16-235 with California State University Channel Islands, to collaborate in the implementation and dissemination of the Promise Pathways to STEM, March 16, 2017 to September 30, 2021, at no cost to the District; Freeman

Enrichment:

- #16-230 with Museum of Ventura County Agriculture Museum, to provide educational, enriching classroom and museum experiences for children; July 1, 2017 through June 30, 2018; at no cost to the District; Freeman

Support Services:

- #16-231 with Channel Islands Lions Club, to provide free eye exams and/or glasses to the students in the Oxnard School District who meet the requirements of not having vision insurance, March 2, 2017 through June 30, 2018; at no cost to the District. Freeman/
Ridge

C.2 Approval of Escrow Agreement #16-236 for Security Deposit in Lieu of Retention – Elm Elementary School Reconstruction Project

It is the recommendation of the Deputy Superintendent, Business & Fiscal Services, and the Director of Purchasing, that the Board of Trustees approve Escrow Agreement #16-236 between Bernards, US Bank National Association, and Oxnard School District, for the retention earnings for the Elm Elementary School Reconstruction Project, Agreement #16-199 for the duration of the project. Dept/School
Cline/
Franz

C.3 Approval of WAL #10 with ATC Group Services LLC For A Soil Management Plan Associated with The Doris/Patterson Site

It is the recommendation of the District Superintendent, and the Deputy Superintendent, Business & Fiscal Services, in consultation with Caldwell Flores Winters, Inc., that the Board of Trustees approve WAL #10 with ATC Group Services LLC in the amount not to exceed \$5,860.00 for a Soil Management Plan associated with the Doris/Patterson site per Master Agreement #13-135 with ATC Group Services LLC; to be paid out of Master Construct and Implementation Program Funds. Dept/School
Dr. Morales/
Cline/
CFW, Inc.

C.4 Approve Request to Attend Out-of-State Conference – Washington, DC

It is the recommendation of the Assistant Superintendent, Educational Services, that the Board of Trustees approve request for Robin Freeman, Assistant Superintendent, Educational Services, to attend the Leaders to Learn From Conference in Washington, DC, March 30-31, 2017; not to exceed \$3,000.00 for registration, airfare, lodging and meals; to be paid with Title II Funds. Dept/School
Freeman

Note: No new items will be considered after 10:00 p.m. in accordance with Board Bylaws, BB 9323 – Meeting Conduct

Section C
CONSENT AGENDA
(continued)

C.5 Personnel Actions

It is recommended that the Board approve personnel actions, as submitted.

Dept/School
Vaca/Koch

**Note: No new items will be considered after 10:00 p.m. in accordance with
Board Bylaws, BB 9323 – Meeting Conduct**

Section D
ACTION ITEMS

(Votes of Individual Board Members must be publicly reported.)

D.1 Consider Approval of Change Order No. 003 to the Construction Services Agreement #15-198 with Swinerton Builders Related to Additional Work Required by the District For the Lemonwood K-8 School Reconstruction (Dr. Morales/Cline, CFW, Inc.)

It is the recommendation of the District Superintendent, and the Deputy Superintendent, Business & Fiscal Services, in conjunction with Caldwell Flores Winters, Inc., that the Board of Trustees approve Change Order No. 003 to the Construction Services Agreement #15-198 with Swinerton Builders, to provide Construction Services related to the Lemonwood Elementary School Reconstruction Project of Measure "R" Program under the Lease-Leaseback delivery method pursuant to Section 17406 of the California Education Code; amount not to exceed \$140,871.57, to be paid out of the Master Construct and Implementation Program Funds.

Public Comment:
Presentation:
Moved:
Seconded:
Board Discussion:
Vote:

ROLL CALL VOTE:

Madrigal Lopez __, Robles-Solis __, O'Leary __, Cordes __, Morrison __

D.2 Consider Approval of Change Order No. 004 to the Construction Services Agreement #15-198 with Swinerton Builders To Adjust the Completion Date and Related Schedule Impact Costs for the Lemonwood K-8 School Reconstruction (Dr. Morales/Cline, CFW, Inc.)

It is the recommendation of the District Superintendent, and the Deputy Superintendent, Business & Fiscal Services, in conjunction with Caldwell Flores Winters, Inc., that the Board of Trustees approve Change Order No. 004 to the Construction Services Agreement #15-198 with Swinerton Builders, to provide Construction Services related to the Lemonwood Elementary School Reconstruction Project of Measure "R" Program under the Lease-Leaseback delivery method pursuant to Section 17406 of the California Education Code; amount not to exceed \$470,695.20, to be paid out of the Master Construct and Implementation Program Funds.

Public Comment:
Presentation:
Moved:
Seconded:
Board Discussion:
Vote:

ROLL CALL VOTE:

Madrigal Lopez __, Robles-Solis __, O'Leary __, Cordes __, Morrison __

D.3 Approval of Dispersal No. 004 from the Lemonwood E.S. Reconstruction Project's Contractor Contingency for Payment of Additional Work Associated with the Project (Dr. Morales/Cline/CFW, Inc.)

It is the recommendation of the District Superintendent, and the Deputy Superintendent, Business & Fiscal Services, in conjunction with Caldwell Flores Winters, Inc., that the Board of Trustees approve Contingency Allocation No. 004 to the Construction Services Agreement #15-198 with Swinerton Builders, for additional items of work related to the Lemonwood Elementary School Reconstruction Project of Measure "R" Program under the Lease-Leaseback delivery method pursuant to Section 17406 of the California Education Code.

Public Comment:
Presentation:
Moved:
Seconded:
Board Discussion:
Vote:

Contractor Contingency Allocation No. 004 will be deducted from the Contractor Contingency line item of the GMP Construction Services Agreement in the amount of \$305,752.62. The Contractor Contingency is included within the approved total of the Construction Services Agreement for the Lemonwood K-8 Reconstruction Project. The Remaining Contractor Contingency Balance after Allocation No. 004 will be \$312,172.60.

ROLL CALL VOTE:

Madrigal Lopez __, Robles-Solis __, O'Leary __, Cordes __, Morrison __

Note: No new items will be considered after 10:00 p.m. in accordance with Board Bylaws, BB 9323 – Meeting Conduct

Section E
APPROVAL OF MINUTES

E.1 Approval of Minutes

It is recommended that the Board approve the minutes of regular board meetings, as submitted:

- January 18, 2017, regular board meeting;
- February 1, 2017, regular board meeting

Moved:
Seconded:
Board Discussion:
Vote:

ROLL CALL VOTE:

Madrigal Lopez __, Robles-Solis __, O'Leary __, Cordes __, Morrison __

**Note: No new items will be considered after 10:00 p.m. in accordance with
Board Bylaws, BB 9323 – Meeting Conduct**

Section F
BOARD POLICIES

(These are presented for discussion or study.
Action may be taken at the discretion of the Board.)

F.1 First Reading of Board Policies, Regulations and Bylaws

It is recommended that the Board review the following revised Board Policies, Administrative Regulations and Bylaws, as presented, and approve for a first reading:

| | | |
|------------------|---|-------|
| Revision AR 3350 | Business and Noninstructional Operations TRAVEL EXPENSES | Cline |
|------------------|---|-------|

**Note: No new items will be considered after 10:00 p.m. in accordance with
Board Bylaws, BB 9323 – Meeting Conduct**

**Section G
CONCLUSION**

G.1 Superintendent’s Announcements *(3 minutes)*

A brief report will be presented concerning noteworthy activities of district staff, matters of general interest to the Board, and pertinent and timely state and federal legislation.

Notes:

G.2 Trustees’ Announcements *(3 minutes each speaker)*

The trustees’ report is provided for the purpose of making announcements, providing conference and visitation summaries, coordinating meeting dates, identifying board representation on committees, and providing other information of general interest.

Notes:

G.3 ADJOURNMENT

Moved:
Seconded:
Vote:

Note: No new items will be considered after 10:00 p.m. in accordance with Board Bylaws, BB 9323 – Meeting Conduct

OSD BOARD AGENDA ITEM

Name of Contributor: Robin I. Freeman

Date of Meeting: 3/1/17

- A. Preliminary Study Session: _____
- B. Hearing: _____
- C. Consent Agenda _____ Agreement Category:
 - _____ Academic
 - _____ Enrichment
 - _____ Special Education
 - _____ Support Services
 - _____ Personnel
 - _____ Legal
 - _____ Facilities
- D. Action Items _____
- E. Report/Discussion Items (no action) _____
- F. Board Policies 1st Reading _____ 2nd Reading _____

Recognition of Students - Honoring Oxnard School District's Million Word Readers (Freeman/Curtis)

Students who have read One Million Words will be recognized by the Board of Trustees. Students will receive a t-shirt that states, "I Read 1,000,000 Words What's your Superpower."

FISCAL IMPACT: None

RECOMMENDATION: It is the recommendation of the Assistant Superintendent, Educational Services that the Board of Trustees accept this item as presented.

ADDITIONAL MATERIAL: None

BOARD AGENDA ITEM

Name of Contributor: Lisa Cline

Date of Meeting: March 1, 2017

- STUDY SESSION _____
- CLOSED SESSION _____
- SECTION A-I: PRELIMINARY _____
- SECTION A-II: REPORTS X
- SECTION B: HEARINGS _____
- SECTION C: CONSENT AGENDA _____

Agreement Category:

- _____ Academic
- _____ Enrichment
- _____ Special Education
- _____ Support Services
- _____ Personnel
- _____ Legal
- _____ Facilities

SECTION D: ACTION _____

SECTION F: BOARD POLICIES 1ST Reading _____ 2nd Reading _____

MEASURE R BOND OVERSIGHT COMMITTEE ANNUAL REPORT (Cline)

The Deputy Superintendent, Business & Fiscal Services, will introduce Mr. Crittenden Ward, Measure R Bond Oversight Committee chair, who will present the Bond Oversight Committee’s fourth annual report to the Board of Trustees as per Proposition 39 requirements.

FISCAL IMPACT

None.

RECOMMENDATION

None – Information only.

ADDITIONAL MATERIAL

Attached: 2016 Measure R Bond Oversight Committee Annual Report (2 pages)

Financial Information

Measure R Bond Sales

Total Authorization: \$90 million
 Series A—\$18.39 million December 2012
 Series B—\$25.5 million May 2013
 Series C – \$15.75 million October 2014
 Series D - \$30.36 million July 2015
 Total Bond Sales: \$90 million

Measure R Bond Oversight Committee

2016 Meeting Dates

February 8, 2016
 June 20, 2016 (No quorum)
 September 12, 2016
 December 12, 2016 (No quorum)

Annual Financial & Performance Audit

The integrity of Measure R funds are audited annually by an independent accounting firm. For fiscal year ending June 30, 2016, the District's auditor was Nigro and Nigro, A Professional Accountancy Corporation. As described in the independent firm's audit report, it is the firm's opinion that the financial statements present fairly, in all material respects, the financial position of the Measure R General Obligation Bond Building Fund as of June 30, 2016, and the changes in financial position thereof for the fiscal year then ended in accordance with accounting principles generally accepted in the United States of America. In regards to the performance audit, the firm's opinion was that the District complied with compliance requirements for the Measure R General Obligation Bond proceeds. The Bond Oversight Committee has reviewed the independent auditor's reports, and together with their other activities, believe that Measure R funds have been spent in accordance with the language of the voter approved Measure and in a manner consistent with applicable State law.

Measure "R" General Obligation Bond Building Fund Statement of Revenues, Expenditures, and Changes in Fund Balance For the Fiscal Year Ended June 30, 2016

| | Measure "R" Building Fund |
|--|------------------------------|
| REVENUES | |
| Interest earnings | \$ 269,258 |
| Other local revenue | 28,559 |
| Total Revenues | 297,817 |
| EXPENDITURES | |
| Current: | |
| Materials and supplies | 1,373,264 |
| Services and other operating expenditures | 2,050,956 |
| Capital outlay | 9,345,665 |
| Total Expenditures | 12,769,885 |
| Excess (Deficiency) of Revenues Over (Under) Expenditures | (12,472,068) |
| OTHER FINANCING SOURCES (USES) | |
| Proceeds from bond issuances | 30,360,000 |
| Premiums from issuance of bonds | 217,717 |
| Total Other Financing Sources (Uses) | 30,577,717 |
| Net Change in Fund Balance | 18,105,649 |
| Fund Balance, July 1, 2015 | 27,392,092 |
| Fund Balance, June 30, 2016 | \$ 45,497,741 |

**There were no audit findings in
 2015-16**

Measure R Bond Oversight Committee

2016 Annual Report to the Community

OXNARD SCHOOL DISTRICT
 March 2017



Elm Community Celebration

The **Measure R Bond Oversight Committee (Committee)** is pleased to report the progress of the Measure R School Facilities Improvement Program. Approved by voters in November 2012, Measure R is a \$90 million General Obligation (G.O.) bond authorization to replace portable classrooms, relieve student overcrowding by building and equipping new classrooms and educational facilities and repairing and equipping existing classrooms and educational facilities throughout the District. The District has issued all of the Measure R bond authorization.

Construction for the new Lemonwood school is underway with construction for Elm to soon follow. The design plans for the new Marshall classroom building are in the final stages of State approval.

The Committee continues to meet for the purpose of actively monitoring all Measure R projects and expenditures, provide proper oversight, controls, and accountability to ensure that Measure R funds are used as they were intended, and make regular reports to the community at-large on the progress of Measure R projects.

All projects are consistent with the project list provided to voters by the District's Board of Trustees. This report provides a summary of program progress and financial information. The Committee will continue to keep the community informed and thank you for your support.

Sincerely,
 Crittenden Ward, Chair
 Measure R Bond Oversight Committee

- **Measure R Bond Oversight Committee**
- Crittenden Ward, Chair
- Community at Large Representative
- Karen Hill Scott, Vice Chair
- Community at Large Representative
- Nancy Lindholm
- Business Organization Representative
- Charles McLaughlin
- Bona-fide Taxpayers Organization Member
- Jeanette Padilla
- Senior Citizens Organization Member
- Teresa Torres
- Parent/Guardian of Enrolled Child
- Jessica Vargas
- PTA/SSC Parent Representative
- The Committee meets at least quarterly. Each member of the committee is appointed by the District's Board of Trustees for a two year term of service.
- Committee minutes and information on bond funded projects are available on the Bond Oversight Committee page located on the Measure R website:
- www.oxnardbondprojects.org
- **Oxnard School District**
- Dr. Cesar Morales
- Superintendent
- **Board of Trustees**
- Veronica Robles-Solis, President
- Debra M. Cordes, Clerk
- Albert Duff Sr., Trustee
- Ernest Morrison, Trustee
- Denis O'Leary, Trustee

Facilities Implementation Program

Program Progress

Educational Reconfiguration

Since adoption of the Facilities Implementation Program, the District has included an educational program focus that provides for the implementation of an extended day kindergarten program, academy programs for 6-8 and K-8 schools, and academic theme focus at the K-5 level. All programs continue to be integrated into the school's overall educational vision and are in the process of adding additional enrichment activities related to the academic themes. Over the course of the year, multiple training sessions have been held with site principals. These training sessions focused on ways to increase the rigor of the curriculum and the development evaluation tools, as well as the continued implementation of the academic themes and academy programs across the District.

New Lemonwood School Takes Shape

In April 2016, the District conducted a groundbreaking ceremony celebrating the start of construction. The event was well received by the community. Construction commenced in May 2016 and is planned to occur over two phases to minimize disruptions to the ongoing educational program with a scheduled construction completion in 2018.

Construction is currently underway which includes a sequence of activities associated with framing, plumbing, electrical, roofing, drywall, and building finishes. When its phased construction is complete, the new Lemonwood school will accommodate 900 students by State standards in grades K-8, including 28 general purpose classrooms, 4 Kindergarten classrooms, 3 science/flex lab classrooms, and 2 special education classrooms. Specified support facilities, administration areas, media center, food service, multipurpose room, physical education spaces, and restrooms will also be provided.

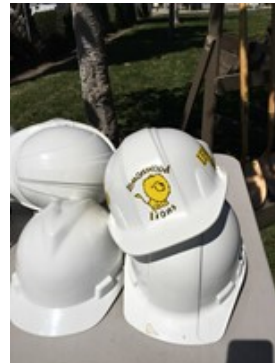

Lemonwood Groundbreaking Event April 2016



Lemonwood Construction Progress December 2016

Phase I Program Progress

To date, all Phase 1 Measure "R" facility improvements are either completed, under construction, or in design. These efforts include the acquisition of the Seabridge elementary school site, the completion of kindergarten and science lab upgrades to 22 classrooms across eight school sites, and the opening of the new Harrington K-5 campus in January 2016.

Construction for the new Lemonwood K-8 school is underway. In December 2016, the Board approved a guaranteed maximum price contract for the construction of the Elm campus. A new 12 classroom building at Marshall is in the final stages of Division of State Architect (DSA) review and approval. The new elementary and middle school site at Doris Avenue and Patterson Road has also undergone active negotiation and planning.



Renderings of Lemonwood Reconstruction



New Elm Campus Renderings



New Marshall Classroom Building Rendering

OSD BOARD AGENDA ITEM

Name of Contributor: Robin I. Freeman

Date of Meeting: 3/1/17

- A. Preliminary _____
Study Session _____
Report X
- B. Hearing: _____
- C. Consent Agenda _____

Agreement Category:
____ Academic
____ Enrichment
____ Special Education
____ Support Services
____ Personnel
____ Legal
____ Facilities

- D. Action Items _____
- E. Approval of Minutes _____
- F. Board Policies 1st Reading _____ 2nd Reading _____

Cal200 Settle Agreement Report (Freeman)

Oxnard School District, as part of the Cal200 Settlement Agreement, agreed to monitor the following actions/conditions related to providing physical education for a total period of time of not less than 200 minutes each 10 schooldays, exclusive of recesses and the lunch period:

- Class Schedules. Each semester, the school site administrator obtains a schedule from the teacher showing the days, times and duration of scheduled Physical Education instruction.
- Publication of Physical Education Schedules. The class schedules are posted on the school website or in each self-contained classroom. Additionally, the schedules are posted in the school's main office. The posting is up for the entire semester.
- Reporting. On at least a monthly basis, the school site administrator collects a signed Reporting Form (from each teacher grades 1-5). The forms are sent to the Assistant Superintendent, Educational Services via the site administrator with a school-wide compliance review.
- Monitoring. On an ongoing basis (monthly), each school site administrator collects and reviews the Reporting Forms and verifies that all teachers who are required to sign the Reporting Forms have provided the required minutes of Physical Education instruction. Also, included in the monthly monitoring are unannounced visits by site administration to at least two classrooms during the time at which Physical Education is scheduled. The site administrator keeps a copy of the visit and includes in the Principal's Report Register all instances in which Physical Education was not observed, and identifies all corrective measures taken to assure that the appropriate number of instructional minutes of instruction are provided. The Principal sends a copy of the Teacher Reporting Form and Principal's Report to the Assistant Superintendent, Educational Services no later than the 5th of the next month.
- Reports to the Governing Board. Within sixty (60) days of the end of each semester, the Assistant Superintendent, Educational Services shall provide a written report to the District's governing board regarding the District's compliance with the agreement. As soon as practical, but no later

than twenty-one (21) days after Board Review, each District shall file a copy of each such Report with the Court, and serve a copy.

Upon a thorough review of the compliance provisions set forth in the Cal200 settlement, staff has determined the Oxnard School District has satisfied all compliance requirements consistent with the agreement and the California Education Code Section 51201.

All required forms documenting compliance have been submitted to the Assistant Superintendent, Educational Services and are on file at the District Office.

RECOMMENDATION:

It is the recommendation of the Assistant Superintendent Educational Services that the Board of Trustees accept the report of the Oxnard School District's compliance with the Cal200 settlement

ADDITIONAL MATERIAL:

None

OSD BOARD AGENDA ITEM

Name of Contributor: Robin Freeman

Date of Meeting: 3/01/17

- Study Session: _____
Closed Session _____
A-1. Preliminary _____
A-II. Reports _____
B. Hearings _____
C. Consent Agenda _____
- Agreement Category:**
 Academic
 Enrichment
 Special Education
 Support Services
 Personnel
 Legal
 Facilities
- D. Action Items _____
F. Board Policies 1st Reading _____ 2nd Reading _____

Approval of Agreement/MOU #16-235 – California State University Channel Islands (Freeman)

California State University Channel Islands (CI), Oxnard College (OC), Oxnard Union High School District (OUHSD), and Oxnard School District agree **to collaborate in the implementation and dissemination** of the Promise Pathways to STEM (Science, Technology, Engineering, and Mathematics) as a pilot program in collaboration with the Ventura County P-20 Council (VC P-20). The Promise Pathways to STEM will provide students in the Oxnard School District with the opportunity of a college education and resources to support them in their path to a college education.

Term of Agreement: **March 16, 2017 through September 30, 2021**

FISCAL IMPACT:

No charge to the Oxnard School District.

RECOMMENDATION:

It is the recommendation of the Assistant Superintendent, Educational Services, that the Board of Trustees approve Agreement/MOU #16-235 with California State University Channel Islands.

ADDITIONAL MATERIAL(S):

Attached: Agreement/MOU #16-235, California State University Channel Islands (3 Pages)

MEMORANDUM OF UNDERSTANDING BETWEEN

**Oxnard College,
California State University Channel Islands,
Oxnard Union High School District,
AND
OxnardSchool District**

Preface: AN AGREEMENT TO INITIATE A PROMISE PATHWAY TO STEM

PURPOSE:

California State University Channel Islands (CI), Oxnard College (OC), Oxnard Union High School District (OUHSD), and Oxnard School District agree **to collaborate in the implementation and dissemination** of the Promise Pathways to STEM (Science, Technology, Engineering, and Mathematics) as a pilot program in collaboration with the Ventura County P-20 Council (VC P-20). The Promise Pathways to STEM will provide students in the Oxnard School District with the opportunity of a college education and resources to support them in their path to a college education.

BACKGROUND:

California State University Channel Islands, Oxnard College, and Oxnard Union High School District will develop a partnership with Oxnard School District, Oceanview School District, and Hueneme Elementary School District to promote higher education as an attainable goal for the students that commit to participating in the Promise Pathways to STEM pilot program.

The Oxnard/Port Hueneme/Camarillo education community has a responsibility to prepare its young people for successful careers in STEM. In order to prepare our young people for success in STEM, we must offer nothing less than a world-class education and the opportunity to pursue a meaningful career. Each student needs and deserves an opportunity to earn a post-secondary credential – and often a college degree. The future of our community depends upon our effectiveness in developing a well-educated workforce in STEM careers and an engaged citizenry to sustain and to advance the economy of our region.

PROMISE PATHWAYS COMMITMENTS:

California State University Channel Islands (CI), Oxnard College (OC), Oxnard Union High School District (OUHSD), promise to develop a Promise Pathways to STEM program including information, services and resources to help students and their families prepare for college beginning in 4th grade and continuing through high school with opportunities that lead to CSU Channel Islands and Oxnard College degree pathways in STEM both directly and via transfer.

We promise to provide the opportunity to earn a bachelor's or advanced degree to all OUHSD and OC students who successfully prepare for college.

CSU Channel Islands (CI) promises that:

- All Oxnard School District students enrolled at Lemonwood Elementary School (grades 6 – 8) who commit to the Promise Pathways to STEM program and, as Oxnard Union High School District students, successfully complete CI minimum college preparatory requirements will be offered admission to CI and have the opportunity to earn a bachelor's degree.

- All Oxnard School District students who commit to Promise Pathways to STEM will receive college preparation services and resources to help them and their families to prepare for college.

CI minimum college preparatory requirements for all graduating Oxnard Union High School District grade twelve students include:

- Graduation from OUHSD
- Completion of the minimum CSU eligibility index requirements
- Completion of college preparatory subject requirements (A-G) totaling 15 courses with a C- or better

Oxnard College (OC) promises that all students in the Oxnard College Promise Pathways to STEM will be offered active assistance in:

- A tuition-free first semester of higher education at Oxnard College
- Learning about and applying for college financial aid
- Transitioning from high school and succeeding in college or career
- STEM workshops and career field trips
- First Year Experience Program
- Priority registration for students who complete assessment, college orientation, and develop an abbreviated education plan with a College Counselor
- Learning about opportunities for transfer to CI or another four-year university
- Completing requirements and applying for transfer to a four-year university

Oxnard School District agrees to partner with California State University Channel Islands (CI), Oxnard College (OC), and Oxnard Union High School District (OUHSD) to cultivate middle school students to commit to the Promise Pathways to STEM program and to work with the district to provide the above mentioned assistance students in grades 6 – 8 at Lemonwood Elementary School.

PROMISE PATHWAYS TO STEM

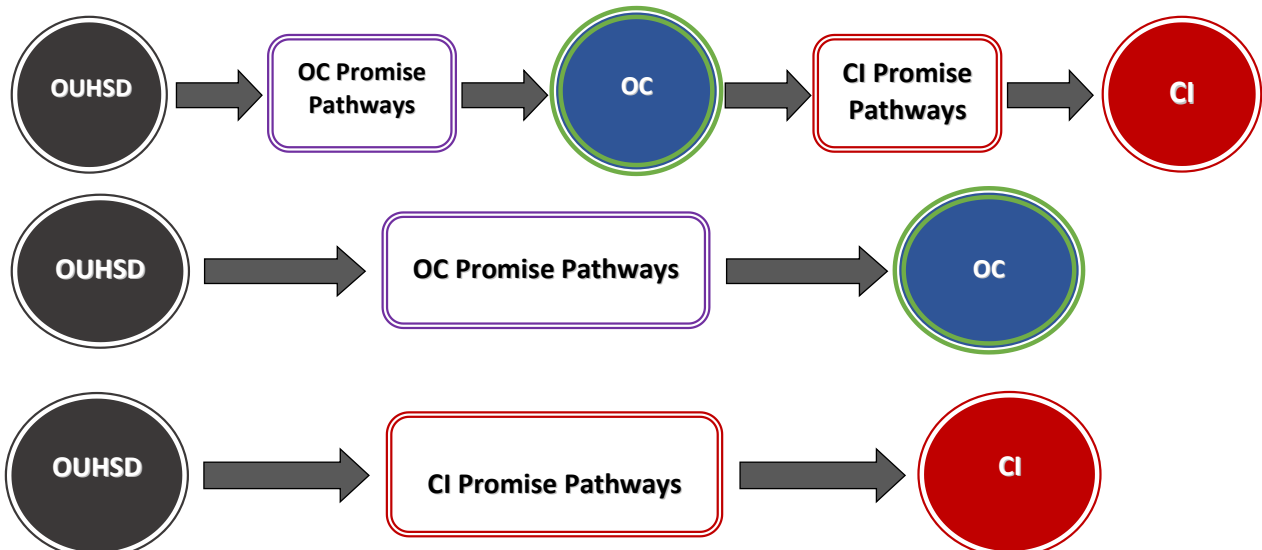

As impact data and other reports on this pilot become available, we commit to having an informed discussion facilitated by the VC P-20 Council to seek models for sustainability and expansion of the program to include additional middle schools with the goal of eventually developing a countywide Promise Program.

PROMISE PATHWAYS AGREEMENT OF UNDERSTANDING

We understand the commitments outlined in this MOU. The agreement to partner on the Promise Pathways Program would be for the period of March 16, 2017 to September 30, 2021. After the program is established, a five year review will be conducted three months prior to the end date of this agreement to review the renewal of the agreement. This is a voluntary agreement. The parties below may terminate participation in this agreement at any time upon thirty days of written notice to all parties involved.

IN WITNESS WHEREOF, the parties hereto have executed this agreement on the day and year last specified below:

Dr. Penelope DeLeon
Oxnard Union High School District
Superintendent

Date:

Dr. Erica Beck
CSU Channel Islands
President
Ventura County P-20 Council
Chair

Date:

Dr. Cynthia Azari
Oxnard College
President

Date:

Mr. Stan Mantooh
Ventura County Office of
Education, Superintendent;
Ventura County P-20 Council, Chair

Date:

Dr. Bernard Luskin
Ventura County Community
College District
Chancellor

Date:

Dr. Cesar Morales
Oxnard School District
Superintendent

Date:

OSD BOARD AGENDA ITEM

Name of Contributor: Robin Freeman

Date of Meeting: 3/01/17

- Study Session:** _____
Closed Session _____
A-1. **Preliminary** _____
A-II. **Reports** _____
B. **Hearings** _____
C. **Consent Agenda** _____
- Agreement Category:**
____ Academic
X **Enrichment**
____ **Special Education**
____ **Support Services**
____ **Personnel**
____ **Legal**
____ **Facilities**
- D. **Action Items** _____
F. **Board Policies** 1st Reading _____ 2nd Reading _____

Approval of Agreement #16-230 – Museum of Ventura County Agriculture Museum (Freeman)

The Museum of Ventura County Agriculture Museum will provide educational, enriching classroom and museum experiences for children that enhance their understanding of Ventura County's agriculture heritage and achieve grade level standards for science, math and nutrition. Teachers will be supported in their effort to provide hands-on learning experiences that improve students' math, science and nutrition skills.

Term of Agreement: **July 1, 2017 through June 30, 2018**

FISCAL IMPACT:

No charge to the Oxnard School District.

RECOMMENDATION:

It is the recommendation of the Assistant Superintendent, Educational Services, that the Board of Trustees approve Agreement #16-230 with Museum of Ventura County Agriculture Museum.

ADDITIONAL MATERIAL(S):

Attached: Agreement #16-230, Museum of Ventura County Agriculture Museum (3 Pages)



MUSEUM of VENTURA COUNTY

100 EAST MAIN STREET • VENTURA, CA 93001-2698 • (805) 653-0323 / FAX (805) 653-5900 www.venturamuseum.org

OSD AGREEMENT #16-230

Partnership Letter

Between the *Museum of Ventura County Agriculture Museum* and the *Oxnard School District*

For Application to the *Monsanto Fund*.

This Partnership Letter continues the *collaborative partnership* between the *Museum of Ventura County Agriculture Museum* and the *Oxnard School District*. The *Museum of Ventura County Agriculture Museum* and the *Oxnard School District* are committed to providing educational, enriching classroom and museum experiences for children that enhance their understanding of Ventura County's agriculture heritage and achieve grade level standards for science, math, and nutrition. The *Museum of Ventura County Agriculture Museum* and *The Oxnard School District* will work together to continue to implement the **Youth Education for Agriculture (YEA!)** program in 2017.

Shared Commitment to an Educational Mission

The *Agriculture Museum* and the *Oxnard School District* have a shared commitment to furthering the educational goals of local children and youth. The *Museum of Ventura County* is an independent non-profit 501(c)(3) organization dedicated to celebrating, preserving, and interpreting the art, history, and culture of Ventura County. The *Agriculture Museum* is a satellite facility of the *Museum of Ventura County*, located in Santa Paula and dedicated to showcasing the past, present, and future of the agricultural industry in Ventura County. The museum shares the *Oxnard School District's* commitment to the district's mission: guaranteeing that each student is academically competitive and inspired to perseverant hope. Together, the Parties enter into this Partnership Agreement to mutually promote and provide the **Youth Education for Agriculture (YEA!)** program. Accordingly, the *Museum of Ventura County Agriculture Museum* and the *Oxnard School District*, operating under this Partnership Agreement agree as follows:

I. PURPOSE AND SCOPE

The *Museum of Ventura County Agriculture Museum* administration and the *Agriculture Museum* Director of Education will work closely with the *Oxnard School District* to implement the **Youth Education for Agriculture (YEA!)** program. The *Museum of Ventura County Agriculture Museum* and the *Oxnard School District* are forming a partnership to further their collective missions and achieve the following outcomes for children attending *Oxnard School District* schools in grades kindergarten through 5:

- Students will benefit from enhanced classroom learning and expand their knowledge of math, science, and nutrition standards.
- Teachers will be supported in their effort to provide hands-on learning experiences that improve students' math, science, and nutrition skills.
- The program will serve 1,500 students and their teachers annually.

II. RESPONSIBILITIES

Evelyn and Howard Boroughs Education and Outreach Center

Board of Directors
2016-2017

Susan Van Abel
Chair

Andrea Pfister
Vice Chair

Fred J. Ferro
Treasurer

Linda Edison
Secretary

John Orr
Past Chair

Bill Bowie
Susan Brown
Bobbi Dufau
Jayme Dwyer
Gail Faulkner
Linda Kimbrough
Susan Pinkerton
Mary Schwabauer
Monica White
Thomas Wolfe

Linda Hadlen
Recording Secretary

Cherie Brant
Docent Volunteer
Council Vice President

Jim Monahan
Ventura City Council

George S. Stuart
Curator Emeritus

Each party will appoint a person to serve as the official contact and coordinate the activities of each organization in carrying out the Agreement. The initial appointees of each organization are:

Elena Brokaw
Interim Executive Director
Museum of Ventura County
(805) 653 – 0323 (Ext. 308)
ebrokaw@venturamusuem.org

Dr. Cesar Morales
Superintendent
Oxnard School District
(805) 385-1501 (Ext. 2032)
drcmorales@oxnardsd.org

The organizations agree to the following tasks for this Partnership Agreement:

- The *Museum of Ventura County Agriculture Museum* will provide the Museum Educator who will continue to develop and implement the *Youth Education for Agriculture (YEA!)* program. This program will provide students and teachers with a standards-based curriculum that builds math, science, and nutrition skills for 1,500 elementary school children annually. The Museum of Ventura County staff will provide hands-on educational *Agriculture Museum* tour that utilizes Ventura County's agricultural heritage to make science, math, and nutrition relevant and interesting. The tours will be offered at the *Agriculture Museum*, which is located in Santa Paula, CA.
- The *Oxnard School District* will work collaboratively with the *Agriculture Museum* to implement the program. It will grant access to teachers and students in participating classrooms as appropriate to market the program and provide classroom services. The *Oxnard School District* will also assist in program outreach by disseminating program information via electronic and print avenues, as appropriate.

III. TERMS OF UNDERSTANDING

The term of this Partnership Agreement is for a period of one year from the effective date of this Agreement, which is expected to be July 1, 2017, and may be extended upon written mutual agreement. Either organization may terminate the partnership at any time without penalties or liabilities.

By signing this Partnership Agreement *the Museum of Ventura County Agriculture Museum* and *the Oxnard School District* agree that the proposed project is aligned with the strategic goals of the school district, and that the

school district is familiar with the staff and organization proposing the partnership.

Authorization:

The signing of this Partnership Agreement is not a formal undertaking. It implies that the signatories will strive to reach, to the best of their ability, the objective stated.

On behalf of the organization I represent, I wish to sign this Partnership Agreement.

Dr. Cesar Morales
Superintendent
Oxnard School District

*Signature _____

*Date _____

Elena Brokaw
Interim Executive Director
Museum of Ventura County

Signature _____

Date _____

OSD BOARD AGENDA ITEM

Name of Contributor: Robin Freeman

Date of Meeting: 3/01/17

- Study Session: _____
Closed Session _____
- A-1. Preliminary _____
A-II. Reports _____
B. Hearings _____
C. Consent Agenda _____
- Agreement Category:
___ Academic
___ Enrichment
___ Special Education
X Support Services
___ Personnel
___ Legal
___ Facilities
- D. Action Items _____
F. Board Policies 1st Reading _____ 2nd Reading _____

Approval of Agreement/MOU #16-231 – Channel Islands Lions Club (Freeman/Ridge)

The purpose of the Agreement/MOU is to establish and maintain a provision of service relationship between the Oxnard School District and Channel Islands Lions Club. Channel Islands Lions Club agrees to provide free eye exams and/or glasses to the students in the Oxnard School District who meet the requirement of not having vision insurance.

FISCAL IMPACT:

None

RECOMMENDATION:

It is the recommendation of the Director, Pupil Services, and the Assistant Superintendent, Educational Services, that the Board of Trustees approve Agreement/MOU #16-231 with the Channel Islands Lions Club.

ADDITIONAL MATERIAL(S):

Attached: Agreement/MOU #16-231, Channel Islands Lions Club (2 Pages)
Lions Vision Coverage Criteria (1 Page)

MEMORANDUM OF UNDERSTANDING #16-231

Channel Islands Lions Club

This Memorandum of Understanding (MOU) is entered into by and between Channel Islands Lions Club and the Oxnard School District.

Purpose: The purpose of the MOU is to establish and maintain a provision of service relationship between two parties, the Oxnard School District and Channel Island Lions Club. Channel Islands Lions Club agrees to provide free eye exams and/or glasses to the students in the Oxnard School District who meet the requirement of not having vision insurance.

Term: The term of this MOU shall commence March 2, 2017 and shall terminate June 30, 2018.

Compensation: The Oxnard School District **will not be charged for the services provided by Channel Island Lions Club**.

Description of Services:

A. Oxnard School District agrees to the following:

1. Verify the student has no vision insurance.
2. Provide a coordinator at each school site.
3. Provide vision referrals by phone.
4. Assist family in coordinating the eye exam appointment.

B. Channel Islands Lions Club agrees to the following:

1. Work with school representative on eye exams and glasses referrals.
2. Authorize for student to receive free eye exams and glasses.

3. Refer to Doctor who accepts Channel Islands Lions Club referrals.
4. Agrees to abide with HIPPA compliance.

Termination: Either party may terminate this MOU without cause upon thirty (30) days written notice.

Authorized Approval:

CHANNEL ISLANDS LIONS CLUB:

OXNARD SCHOOL DISTRICT:

Signature

Signature

Howard W. Rowe, Sight Chairman

Lisa A. Franz, Director, Purchasing

Typed Name/Title

Typed Name/Title

Date

Date



We Serve Because We Care

Channel Islands Lions Club

Oxnard, California 93030

LIONS VISION COVERAGE CRITERIA:

1. Child or other client must reside in the Oxnard/Port Hueneme area.\
2. She or he must be needy and have no MediCal or Medicaid coverage for eye exams and /or glasses.
3. Child or adult client representative must do a careful evaluation of child or adult client then receive authorization from the Lions Sight Chairman, H. Wayne Rowe 486-9534 for eye exam and/or glasses.
4. After authorization is made voucher(s) for eye exam and/or glasses with the child or adult client name will be faxed by the Sight Chairman to Dr. Christian Wilson, 4051 East Main Street. Ventura.
5. Child or adult client representative is responsible for arranging transportation to, and making the appointment with Dr. Wilson 4051 East Main Street, Phone 650-8406 (across from K-Mart).
6. If the child or adult client has had a prescription for glasses within the last year an appointment with Eyeglass Factory 642-2222 for "glasses only" must be made by the representative. The Eyeglass Factory is next door to Dr. Wilson and a voucher will be sent to them by the Sight Chairman prior to the appointment being made
7. Service will usually only be provided for needy children, adult needy and homeless, and general relief individuals with a legitimate need for glasses (for school, work or for obtaining work). Other needs will be addressed by the Sight Chairman and are subject to Lions fund availability. These funds are limited by monies raised by Lions in community projects.

H. Wayne Rowe
H. Wayne Rowe
Sight Chairman

BOARD AGENDA ITEM

Name of Contributor: Lisa Cline

Date of Meeting: 3/01/17

- STUDY SESSION** _____
- CLOSED SESSION** _____
- SECTION A-1: PRELIMINARY** _____
- SECTION A-II: REPORTS** _____
- SECTION B: HEARINGS** _____
- SECTION C: CONSENT AGENDA** _____

- Agreement Category:
- _____ Academic
 - _____ Enrichment
 - _____ Special Education
 - _____ Support Services
 - _____ Personnel
 - _____ Legal
 - X** Facilities

SECTION D: ACTION _____

SECTION F: BOARD POLICIES 1st Reading _____ 2nd Reading _____

Approval of Escrow Agreement #16-236 for Security Deposit in Lieu of Retention – Elm Elementary School Reconstruction Project (Cline/Franz)

Pursuant to Section 22300 of the Public Contract Code of the State of California, Contractor has the option to deposit securities with Escrow Agent as substitute for retention earnings required to be withheld by Owner. Pursuant to the construction agreement entered into between Oxnard School District and Bernards for the Elm Elementary School Reconstruction Project, Agreement #16-199, in the amount of Twenty-Three Million Three Hundred Six Thousand Eight Hundred Eighty-Six Dollars (\$23,306,886.00), the contractor is requesting retention earnings be directed to an Escrow Agent.

Approval is sought for Escrow Agreement #16-236 between Bernards, US Bank National Association, and Oxnard School District, for the retention earnings for the Elm Elementary School Reconstruction Project, Agreement #16-199.

FISCAL IMPACT:

None

RECOMMENDATION:

It is the recommendation of the Director, Purchasing, and the Deputy Superintendent, Business & Fiscal Services, that the Board of Trustees approve Escrow Agreement #16-236 between Bernards, US Bank National Association, and Oxnard School District, for the retention earnings for the Elm Elementary School Reconstruction Project, Agreement #16-199 for the duration of the project.

ADDITIONAL MATERIAL(S):

Attached: Agreement #16-236, US Bank National Association/Bernards (3 Pages)

OSD AGREEMENT #16-236

**ESCROW AGREEMENT FOR SECURITY DEPOSITS IN THE FORM OF
CERTIFICATES OF DEPOSITS OR CASH**

This Escrow Agreement is made and entered into by and between:

Oxnard School District, whose address is 1051 South A Street, Oxnard, CA 93030 hereinafter called "Owner" and

BERNARDS BROS. INC. dba BERNARDS whose address is 555 First Street, San Fernando, CA 91340 hereinafter called "Contractor" and

U.S. Bank National Association whose address is Deposit and Payment Solutions Division, 633 W. Fifth Street, 30th Floor, Los Angeles, CA 90071, hereinafter called "Escrow Agent".

For the consideration hereinafter set forth, the Owner, Contractor and Escrow Agent, agree as follows:

(1) Pursuant to Section 22300 of the Public Contract Code of the state of California, Contractor has the option to deposit securities with Escrow Agent as a substitute for retention earnings required to be withheld by Owner pursuant to the Construction Contract entered into between the Owner and Contractor for **Project: Elm Elementary School Re-Construction Project** in the amount of **\$23,306,886** dated **December 14, 2016** (hereinafter referred to as the "Contract"). Alternatively, on written request of the Contractor, the Owner shall make payments of the retention earnings directly to the Escrow Agent. When Contractor deposits the securities as a substitute for Contract earnings the Escrow Agent shall notify the Owner within ten (10) days of the deposit. The market value of the securities at the time of the substitution shall be at least equal to the cash amount then required to be withheld as retention under the terms of the Contract between the Owner and Contractor. Securities shall be held in the name of the Owner and shall designate the Contractor as beneficial owner.

(2) The Owner shall make progress payments to the Contractor for those funds which otherwise would be withheld from progress payments pursuant to the Contract provisions, provided that the Escrow Agent holds securities in the form and amount specified above.

(3) When the Owner makes payment of retention earned directly to the Escrow Agent, the Escrow Agent shall hold them for the benefit of the Contractor until the time that the Escrow created under this contract is terminated. The Contractor may direct the investment of the payments into securities. All terms and conditions of this agreement and the rights and responsibilities of the parties shall be equally applicable and binding when the Owner pays the Escrow Agent directly.

(4) Contractor shall be responsible for paying all fees for the expenses incurred by Escrow Agent in administering the Escrow account and all expenses of the Owner. These expenses and payment terms shall be determined by the Owner, Contractor and Escrow Agent.

(5) The interest earned on the securities or the money market accounts held in Escrow and all interest earned on that interest shall be for the sole account of Contractor and shall be subject to withdrawal by Contractor at any time and from time to time without notice to the Owner.

(6) Contractor shall have the right to withdraw all or any part of the principal in the Escrow account only by written notice to the Escrow Agent accompanied by written authorization from Owner to the Escrow Agent that Owner consents to the withdrawal of the amount sought to be withdrawn by Contractor.

(7) The Owner shall have a right to draw upon the securities in the event of default by the Contractor. Upon seven days' written notice to the Escrow Agent from the owner of the default, the Escrow Agent shall immediately convert the securities to cash and shall distribute the cash as instructed by the Owner.

(8) Upon receipt of written notification from the Owner certifying that the Contract is final and complete, and that the Contractor has complied with all requirements and procedures applicable to the Contract, Escrow Agent shall release to Contractor all securities and interest on deposit less escrow fees and charges of the Escrow Account. The Escrow shall be closed immediately upon disbursement of all monies and securities on deposit and payments of fees and charges.

(9) Escrow Agent shall rely on the written notifications from the Owner and Contractor pursuant to Sections (5) to (8), inclusive of this Agreement and the Owner and Contractor shall hold Escrow Agent harmless from Escrow Agent's release and disbursement of the securities and interest as set forth above.

(10) The names of the persons who are authorized to give written notice or to receive written notice on behalf of the Owner and on behalf of the Contractor in connection with the foregoing, and exemplars of their respective signatures, are as follows:

| | |
|---|---|
| <p>On behalf of the Owner - Oxnard School District:</p> <p>By: _____ Lisa A. Franz Director, Purchasing</p> | <p>On behalf of the Contractor - Bernards Bros. Inc. dba Bernards:</p> <p>By: _____ Ken Menager Chief Financial Officer</p> |
| <p>Address: 1051 South A Street Oxnard, CA 93030</p> | <p>Address: 555 First Street San Fernando, CA 91340</p> |
| <p>On behalf of the Escrow Agent - U.S. Bank National Association:</p> <p>By: _____ John Wong Vice President</p> | |
| <p>Address: Deposit & Payment Solutions Division 633 W. Fifth Street, 30th Floor Los Angeles, CA 90071</p> | |

At the time the Escrow account is opened, the Owner and Contractor shall deliver to the Escrow Agent a fully executed counterpart of this Agreement.

IN WITNESS WHEREOF, the parties have executed this Agreement by their proper officers on the date set forth below.

Owner:
Oxnard School District

By: _____
Lisa A. Franz
Director, Purchasing

Date: _____

Escrow Agent:
U.S. Bank National Association

By: _____
John Wong
Vice President

Date: _____

Contractor:
Bernards Bros. Inc.
dba Bernards

By: _____
Ken Menager
Chief Financial Officer

Date: _____

BOARD AGENDA ITEM

Name of Contributor: Dr. Cesar Morales/Lisa Cline

Date of Meeting: 3/01/17

STUDY SESSION _____

CLOSED SESSION _____

SECTION A-1: PRELIMINARY _____

SECTION A-II: REPORTS _____

SECTION B: HEARINGS _____

SECTION C: CONSENT AGENDA _____

Agreement Category:

____ Academic

____ Enrichment

____ Special Education

____ Support Services

____ Personnel

____ Legal

X Facilities

SECTION D: ACTION _____

SECTION F: BOARD POLICIES 1st Reading _____ 2nd Reading _____

APPROVAL OF WAL #10 WITH ATC GROUP SERVICES LLC FOR A SOIL MANAGEMENT PLAN ASSOCIATED WITH THE DORIS/PATTERSON SITE (Morales/Cline/CFW)

To assist with evaluating the suitability for use as a possible school site, the Oxnard School District (District) has conducted various required environmental studies related to the acquisition of 25 acres located at the intersection of Doris Avenue and Patterson Road. As required by the Department of Toxic Substances Control (DTSC), a Preliminary Environmental Assessment (PEA) report has been prepared by ATC Group Services LLC for the Doris/Patterson site.

The PEA report recommends that a Soil Management Plan (SMP) be prepared in conjunction with a deed restriction for the property. The SMP will require DTSC review and approval and detailed actions to be undertaken whenever soils at the site are disturbed during both planned and unplanned future construction activities at the site. Once the DTSC approves the SMP, the District would need to accept and enter into a long term deed restriction (Land Use Covenant) for the property which would restrict the property to non-residential uses.

The attached WAL provides the scope of work required for ATC Group Services LLC to prepare the SMP for a total not to exceed fee of \$5,860.00. District staff, in consultation with Caldwell Flores Winters, Inc., recommend that the Board of Trustees approve WAL #10 with ATC Group Services LLC as follows:

Master Agreement: #13-135
WAL: WAL #10
Consultant: ATC Group Services LLC (formerly Cardno ATC)
Date Issued: March 2, 2017
Amount: \$5,860.00 (not to exceed)

FISCAL IMPACT

\$5,860.00 to be paid out of Master Construct and Implementation Program funds.

RECOMMENDATION

It is the recommendation of the Superintendent, and the Deputy Superintendent, Business and Fiscal Services, in consultation with Caldwell Flores Winters, that the Board of Trustees approve WAL #10 with ATC Group Services LLC in the amount not to exceed \$5,860.00 for a Soil Management Plan associated with the Doris/Patterson site per Master Agreement #13-135 with ATC Group Services LLC.

ADDITIONAL MATERIAL

Attached: WAL #10, ATC Group Services LLC (formerly Cardno ATC) (6 Pages)
 Master Agreement #13-135, Cardno ATC (32 Pages)



WORK AUTHORIZATION LETTER

GENERAL INFORMATION

| | |
|--|-----------------------|
| PROJECT #: N/A | DATE: 3/2/2017 |
| SITE NAME: Doris/Patterson Site | DSA # |
| MASTER AGREEMENT #: 13-135 | OPSC # |
| WAL #: 10 | VENDOR ID: |

PURSUANT TO MASTER AGREEMENT BETWEEN:

DISTRICT

CONSULTANT

OXNARD SCHOOL DISTRICT
 1051 South A Street
 Oxnard, CA 93030
 (805) 385-1501

Firm Name:
 Street:
 City, State, Zip:
 Phone:

ATC Group Services LLC
 25 Cupania Circle
 Monterey Park, CA 91755
 323-517-9780

SCOPE OF SERVICES TO BE PERFORMED UNDER THIS WAL

ATC has prepared a Preliminary Environmental Assessment (PEA) for the Doris/Patterson site. The PEA report recommends that a deed restriction be recorded for the site and that a Soil Management Plan (SMP) be prepared. The SMP will detail actions to be undertaken whenever soils at the site are disturbed during both planned and unplanned future construction activities at the site. ATC will perform the scope of work as described in the attached proposal dated February 9, 2017.
(ATTACH ADDITIONAL PAGES AS NECESSARY)

SCHEDULE OF SERVICES TO BE PERFORMED UNDER THIS WAL

| | |
|-----------------------------|----------------------------------|
| START DATE: 3/2/2017 | COMPLETION DATE: 4/2/2017 |
|-----------------------------|----------------------------------|

FIXED FEE AMOUNT: \$5,860

This fee amount is based upon Consultant's proposal dated 2/9/2017 and subsequent negotiations mutually agreed to by all parties

This WAL is inherently a part of the Master Agreement referenced above. It is bound by the general terms and conditions of the Master Agreement. This WAL describes in detail the Consultants specific Scope of Services, agreed upon lump sum fixed fee, agreed upon schedule for completion of Services, and other provisions required to clearly indicate the required Services, and terms of this WAL.

This WAL and associated Master Agreement hereby supercede any and all terms, conditions, and other provisions of the Consultant's Proposal; and such terms, conditions, and other provisions are null and void, and are not incorporated to any extent as part of this WAL and associated Master Agreement whether or not they are directly superceded by this WAL and/or the associated Master Agreement.

IN WITNESS THEREOF, THE PARTIES HAVE AGREED TO AND EXECUTED THIS WAL AS SET FORTH BELOW:

DISTRICT

CONSULTANT

OXNARD SCHOOL DISTRICT

CONSULTANT

(SIGNATURE)

(DATE)

(SIGNATURE)

(DATE)

FOR DISTRICT USE ONLY

PROJECT MANAGER: Patricia Raphael Garcia (CFW)
 P.O. #

PREPARED BY: Patricia Raphael Garcia (CFW)
 P.O. AMOUNT:

SOURCE OF FUNDS: MEASURE "R" DEF. MAINT. DEV. FEES OTHER Master Construct and Implementation Program

COST ID: 6171 - Environmental Studies

(PM APPROVAL SIGNATURE)

(DATE)

SPECIAL INSTRUCTIONS:



25 Cupania Circle
Monterey Park, CA 91755
Telephone 323-517-9780
Fax 323-517-9781
www.atcgroupservices.com

February 9, 2017

Patricia Raphael Garcia
Oxnard School District
c/o Caldwell Flores Winter, Inc.
1901 S. Victoria Avenue, Suite 106
Oxnard, California, 93035

Sent via email: praphael@cfwinc.com

RE: Proposal for Soil Management Plan/Deed Restriction
Proposed Elementary and Middle Schools
Southeast Corner of Doris Avenue and North Patterson Road
Oxnard, California 93030
ATC Proposal Number: 10116-2017-02-0047

Dear Ms. Garcia:

ATC Group Services LLC (ATC) is pleased to submit this Proposal to the Oxnard School District (OSD) for additional work associated with the proposed Doris/Patterson school site located at the southeast corner of Doris Avenue and North Patterson Road in Oxnard, California. ATC prepared a *Preliminary Endangerment Assessment (PEA) Report* dated February 8, 2017 which recommends a deed restriction be recorded for the site and that a Soil Management Plan (SMP) be prepared to address residual pesticides detected in soil at the site.

The Department of Toxic Substances Control (DTSC) has yet to respond to ATC's PEA report; however, it is ATC's understanding that due to timeline constraints, the OSD requested a cost proposal for both the SMP and deed restriction. Both proposed scopes of work and associated costs are presented below.

PROPOSED SCOPE OF WORK

It is ATC's expectation that negotiation of a deed restriction for the site via a Land Use Covenant Agreement (LUCA) will be performed primarily between the OSD and the DTSC; however, ATC has included a limited amount of time in the proposal budget to assist with drafting the LUCA.



Prior to the LUCA being finalized with the DTSC, ATC will prepare a SMP. The SMP may be used for internal purposes or to address DTSC requirements, if applicable. The SMP will detail actions to be undertaken whenever soils at the site are disturbed during both planned and unplanned future construction activities at the site. The SMP will include:

- The preparation of a Health and Safety Plan which outlines both hazardous conditions that may be encountered at the site and the minimum personal protective equipment requirements for all site workers.
- Appropriate dust suppression measures to take when excavating and/or stockpiling soil on-site.
- Appropriate stockpiling procedures for excavated soils, including recommended chemical analyses to perform on the stockpiled soil, and guidance on how many samples of the stockpiled soil are to be collected.
- Guidance pertaining to appropriate off-site disposal of excavated and stockpiled soil.
- Provisions for sampling and analysis of imported soil to be utilized onsite during construction.
- DTSC reporting requirements.

The SMP will be reviewed and signed by a State of California Professional Geologist.

FEE ESTIMATE

ATC proposes to complete the proposed scope of work on a Time and Materials basis. The SMP, and LUCA assistance can be completed for an estimated amount of **\$5,860.00**. A breakdown of costs is provided on the spreadsheet below.

ATC will not exceed the cost estimates for the scope of work without written authorization from the Client. Should the Client require additional work, such as consultation beyond the number of hours estimated to complete this project, extensive report revisions, additional copies of the reports, consultation with attorneys, etc., the same unit rates listed on ATC's standard fee schedule will be applicable. **Please note that the actual requirements are at the discretion of the DTSC. Should DTSC require revisions to the SMP, the proposed scope of work and estimated cost may warrant modification.**



AUTHORIZATION

ATC appreciates the opportunity to present this proposal and looks forward to working with Caldwell Flores Winters, Inc. and OSD on this project. If this proposal is acceptable to you and you would like ATC to schedule this project, please forward a Work Authorization Letter under the existing Agreement. If you have any questions regarding this proposal, please contact our office at (323) 517-9780.

Sincerely,
ATC Group Services

A handwritten signature in blue ink, appearing to read "Greg Buchanan".

Greg Buchanan, PG
Senior Project Manager
Direct Line 323-517-9680
Email: greg.buchanan@atcassociates.com

A handwritten signature in black ink, appearing to read "Todd Stanford".

Todd Stanford, REHS, CEM
Principal Scientist
Direct Line 818-259-0749
todd.stanford@atcassociates.com

Attachments: List of Assumptions
Estimated Cost Breakdowns



LIST OF ASSUMPTIONS

1. DTSC oversight fees will be charged to the District and are not included in this proposal.
2. Please note that the actual post-PEA requirements are at the discretion of the DTSC, and significant modification to the scope of work, including additional sampling and reporting could be required by the DTSC. Any additional scope items, including but not limited to meetings, project management, and reporting required by the DTSC will be charged on a time and materials basis, pending client approval.
3. Public outreach activities, beyond participation in one public meeting as part of the PEA process, are not included in this proposal. ATC can provide additional services on a time and materials basis in accordance with our current fee schedule.
4. This proposal includes estimated effort to prepare the SMP and assist in drafting the LUCA. The proposal shall be modified based on DTSC requirements, if necessary. Should DTSC require that the SMP be revised to incorporate additional comments, the actual SMP costs may be higher than estimated in this proposal.
5. There are no material changes in site conditions from those described.
6. No field work by ATC will be required; if field work is required, it will be performed on a time and materials basis in accordance with our current fee schedule.
7. The scope of services is restricted to that which is outlined in this proposal.
8. Any subcontracted charges will be billed at their actual cost, plus a 10% mark-up.



Estimated Cost Breakdown – SMP and LUCA

| Deed Restriction and General Project Support | | | | | |
|---|----------|-----|--|----|-------------------|
| Principal | \$115.00 | Hr. | | 15 | \$1,725.00 |
| subtotal | | | | | \$1,725.00 |
| Soil Management Plan Preparation | | | | | |
| Principal | \$115.00 | Hr. | | 20 | \$2,300.00 |
| Senior Project Manager | \$85.00 | Hr. | | 20 | \$1,700.00 |
| CADD | \$45.00 | Hr. | | 3 | \$135.00 |
| subtotal | | | | | \$4,135.00 |
| GRAND TOTAL | | | | | \$5,860.00 |

**OXNARD SCHOOL DISTRICT
AGREEMENT FOR CONSULTANT SERVICES
(MASTER AGREEMENT – HAZARDOUS MATERIALS SURVEY & TESTING)**

This Agreement for Consultant Services (“Agreement”) is entered into as of this 13th day of November, 2013 by and between the **Oxnard School District** (“District”), with offices located at 1051 South A Street, Oxnard, CA 93030, and **Cardno ATC** (“Consultant”) with a business address at 25 Cupania Circle, Monterey Park, CA 91755. District and Consultant are sometimes hereinafter individually referred to as “Party” and hereinafter collectively referred to as the “Parties.”

RECITALS

A. District is authorized by *California Government Code* Section 53060, and Board Policy 4368, to contract with independent contractors for the furnishing of services concerning financial, economic, accounting, engineering, legal, administrative and other matters. District has sought, by issuance of a Request for Qualifications, the performance of certain services, with the precise scope of work to be specified at the time of assignment of work.

B. Following submission of a Statement of Qualifications for the performance of services, Consultant was prequalified by District to perform services on behalf of District that may be assigned, or not assigned, at the District’s sole discretion.

C. The Parties desire to formalize the prequalification of Consultant for performance of services and desire that the terms of that performance be as particularly defined and described herein.

OPERATIVE PROVISIONS

NOW, THEREFORE, in consideration of the mutual promises and covenants made by the Parties and contained herein and other consideration, the value and adequacy of which are hereby acknowledged, the Parties agree as follows:

1. **Incorporation of Recitals and Exhibits.** The Recitals set forth above and all exhibits attached to this Agreement, as hereafter amended, are incorporated by this reference as if fully set forth herein.
2. **Master Agreement.** This Agreement sets forth the basic terms and conditions between District and Consultant. It may be supplemented from time to time with an individual Work Authorization Letter (“WAL”) which shall be considered an amendment to this Agreement, and which shall be subject to all the terms and conditions of this Agreement, and any further terms and conditions as set forth in the WAL.
3. **Scope of Services.** The scope of Services to be assigned to Consultant pursuant to a WAL is further defined in **Exhibit F – Scope of Services**, wherein the general responsibilities of Consultant are described pursuant to the discipline(s) for which the Consultant has been deemed prequalified by District as described in this Agreement.
4. **Agreement, Scope of Work, and Assignment of Projects.** District may, from time to time, and at the sole discretion of District, assign to Consultant specific services to be performed by Consultant (the “Services”) pursuant to a WAL. The WAL assignment procedure and associated forms are set forth in **Exhibit A**, which is attached hereto. This Agreement, together with the WAL, sets forth the terms and conditions pursuant to which Consultant will perform such Services on behalf of District. The WAL

RECEIVED NOV 01 2013
CFW

shall particularize and describe, among other things, such project(s) for which Consultant is to perform Services, such Services to be performed by Consultant at such project(s), the timeline for the performance of such Services, and the compensation to be paid to Consultant for the performance of such Services.

5. **Term of Agreement.** Subject to earlier termination as provided below, this Agreement shall remain in effect from November 13, 2013 through November 12, 2018 (the “Term”). This Agreement may be extended only by amendment, signed by the Parties, prior to the expiration of the Term. Such agreement for extension shall be based upon the showing of good and sufficient cause by Consultant that such extension(s) shall be granted. District shall not be obligated to compensate Consultant for any additional costs if such an extension has been granted to this Agreement. Any provision for additional compensation shall be accommodated via the WAL process as indicated in **Exhibit A**.
6. **Time for Performance.** The scope of the Services set forth in the WAL shall be completed during the Term pursuant to the schedule specified in the WAL. If Services indicated in the WAL cannot be completed within the schedule set forth in the WAL, or if the schedule exceeds the Term of this Agreement, it is the responsibility of Consultant to notify District at least ninety (90) days prior to the expiration of either, with a request for a time extension clearly identifying the cause(s) for the failure to complete the Services within the schedule and/or the Term. Should Consultant fail to provide such notice, and/or the Services not be completed pursuant to that schedule or within the Term, Consultant shall be deemed to be in Default as provided below. District, in its sole discretion, may choose not to enforce the Default provisions of this Agreement and may instead allow Consultant to continue performing the Services.
7. **Additional Services.** Additional Services are services in addition to the Services set forth in the WAL that are provided by Consultant pursuant to a written request by District. Additional Services will require a written request or pre-authorization in writing by District following specific approval of such services by the District Board of Trustees. It is understood and agreed that Consultant shall not perform any Additional Services unless and until Consultant receives specific written approval for such Additional Services from the District Board of Trustees. Any modification of the compensation to be paid to Consultant as a result of Additional Services must be specifically approved in writing by the District Board of Trustees. In the event that the District Board of Trustees approves in writing a modification of the compensation, then Consultant shall be paid for such Additional Services pursuant to Section 8, below. However, it is understood and agreed that if the cause of the Additional Services is the sole or partial responsibility of Consultant, its agents, or any subconsultants or other parties under the charge of Consultant, no additional compensation shall be paid to Consultant. If such conditions exist so as to justify Additional Services as indicated above, which require additional compensation or time in order to be performed, it is the sole responsibility of Consultant to submit a request for Additional Services within ten (10) days of Consultant’s discovery of such conditions which require Additional Services. It is understood and agreed that if Consultant performs any services that it claims are Additional Services without receiving prior written approval from the District Board of Trustees, Consultant shall not be paid for such claimed Additional Services.
8. **Compensation and Method of Payment.** This Agreement does not guarantee that District will issue a WAL to Consultant nor does this Agreement guarantee any compensation to Consultant. This Agreement does not create any obligation on the part of District to compensate Consultant absent a WAL indicating compensation due to Consultant once Services are performed. Specific compensation and payment amounts, including approved reimbursable expenses, shall be set forth in the WAL. However, it is understood and agreed that the compensation to be paid to Consultant shall not be in excess of or exceed the rates set forth in Exhibit **B** “Compensation”.

a. Each month Consultant shall furnish to District an original invoice for all work performed and expenses incurred during the preceding month for Services performed pursuant to a WAL. The invoice shall clearly indicate the assigned project, the approved WAL, and shall detail charges by the following categories: labor (by sub-category), travel, materials, equipment, supplies, and sub-consultant contracts. Sub-consultant charges, if any, shall be detailed by the following categories: labor, travel, materials, equipment and supplies. District shall independently review each invoice submitted by Consultant to determine whether the work performed and expenses incurred are in compliance with the provisions of this Agreement and the WAL. In the event that no charges or expenses are disputed, the invoice shall be approved and paid according to the terms set forth in subsection b. In the event any charges or expenses are disputed by District, the original invoice shall be returned by District to Consultant for correction and resubmission.

b. Except as to any charges for work performed or expenses incurred by Consultant which are disputed by District, District will use its best efforts to cause Consultant to be paid within forty-five (45) days of receipt of Consultant's correct and undisputed invoice.

c. Payment to Consultant for work performed pursuant to this Agreement and a WAL shall not be deemed to waive any defects in work performed by Consultant.

9. Responsibilities of Consultant:

a. Consultant shall perform all Services as indicated in this Agreement and the WAL to the satisfaction of District.

b. The specific Services of Consultant to be performed shall be indicated in the WAL.

c. Consultant hereby represents and warrants that (a) it is an experienced consultant in the discipline(s) identified in **Exhibit F**, having the skill and the legal and professional ability and the flexibility necessary to perform all of the Services required under this Agreement; (b) it has the capabilities and resources necessary to perform its obligations hereunder; (c) it is familiar with all current laws, rules, regulations and other restrictions which are and may become applicable to the scope of Services under this Agreement, including but not limited to all local ordinances, building codes, and requirements of all Authorities Having Jurisdiction (AHJ) including but not limited to the Division of State Architect (DSA), the Office of Public School Construction (OPSC), the State Facilities Planning Division (SFPD), California Department of Education (CDE), the California Department of General Services (DGS), the Department of Toxic Substances Control (DTSC), the California Environmental Quality Act (CEQA), Title 24 of the California Code of Regulations, the California Education Code, State and Local Fire Authorities, air quality districts, water quality and control boards, and any/all other AHJ; (d) that it will assume full responsibility for all Services performed and all work prepared and furnished to District by its employees, agents, and subconsultants; (e) that it has sufficient financial strength and resources to undertake and complete the Services provided for under this Agreement within the schedule set forth in the WAL; and (f) that it certifies and covenants that all reports, certifications, studies, analyses, and other documents prepared by Consultant shall be prepared in accordance with all applicable laws, rules, regulations, and other requirements in effect at the time of their preparation, or required at their time of submittal to District and or agencies.

d. Consultant shall follow accepted industry standards and practices and comply with all federal, state, and local laws and ordinances applicable to the Services required by this Agreement and the WAL.

10. Responsibilities of District.

- a. District will prepare and furnish to Consultant upon Consultant's request, such information as is reasonably necessary to the performance of the Services required under this Agreement and the WAL. Consultant understands that all information provided to Consultant remains the property of District and shall only be removed from District's possession/premises and/or be photocopied, reproduced, distributed, or otherwise made available to others if such activities are expressly approved in writing by District and/or the Program Manager. Failure to comply with the above requirements shall be reasonable cause for termination of this Agreement, and may subject Consultant to liability for damages to District.
 - b. If needed by Consultant, District shall provide information as to the requirements and educational program for each project assigned by a WAL, including approved budget and schedule limitations.
 - c. District shall facilitate and coordinate cooperation amongst and between District consultants, including but not limited to architects, construction managers, surveyors, geotechnical engineers, inspectors, testing laboratories, hazardous materials specialists, CEQA/DTSC compliance specialists, technology experts, and any other professional consultants District deems necessary to execute the Facilities Implementation Program. Such coordination shall include the distribution of documentation prepared by individual consultants which may be of service to Consultant in the course of completing the Services.
 - d. District shall facilitate and coordinate cooperation amongst and between District staff and Consultant, as required to complete the Services.
 - e. District shall provide for the timely approval and execution of the WALs, Additional Services requests, invoices, and any other documentation that requires District action in order for Consultant to complete the Services.
11. **Suspension.** District may, for any reason or no reason, in District's sole discretion, suspend all or a portion of this Agreement, the WAL, or the Services by giving ten (10) calendar days written notice of suspension to Consultant. In the event such notice is given, Consultant shall cease immediately all work in progress. If District suspends the Services for a period of ninety (90) consecutive calendar days or more and, in addition, if such suspension is not caused by Consultant or the acts or omissions of Consultant, then if the Services are resumed, Consultant's compensation shall be subject to adjustment to provide for actual direct costs and expenses incurred by Consultant as a direct result of the suspension and resumption by District of the Services.
12. **Termination.** This Agreement, the WAL, or the Services may be terminated at any time by mutual agreement of the Parties or by either Party as follows:
- a. District may terminate all or a portion of this Agreement, the WAL, or the Services without cause at any time by giving ten (10) calendar days written notice of termination to Consultant. In the event such notice is given, Consultant shall cease immediately all work in progress; or
 - b. District may terminate all or a portion of this Agreement, the WAL, or the Services for cause in the event of a Default by giving written notice pursuant to Section 15, below; or
 - c. Consultant may terminate this Agreement or the WAL at any time upon thirty (30) calendar days written notice if District fails to make any undisputed payment to Consultant when due and such failure remains uncured for forty-five (45) calendar days after written notice to District.

13. **Similar or Identical Services.** In the event that this Agreement, the WAL, or any of the Services are terminated in whole or in part as provided herein, District may procure, upon such terms and in such manner as District may determine appropriate, services similar or identical to those terminated to complete any unfinished Services or new services as needed by District.
14. **Inspection and Final Acceptance.** District acceptance of any of work or Services, whether specifically in writing or by virtue of payment, shall not constitute a waiver of any of the provisions of this Agreement or the WAL including, but not limited to, indemnification and insurance provisions.
15. **Default.** Failure of Consultant to perform any Services or comply with any provisions of this Agreement or the WAL constitutes a Default. District may terminate all or any portion of this Agreement, the WAL, or the Services for cause in the event of a Default. The termination shall be effective if Consultant fails to cure such Default within thirty (30) calendar days following issuance of written notice thereof by District, or if the cure by its nature takes longer, fails to commence such cure within thirty (30) calendar days from the date of issuance of the notice and diligently prosecutes such cure to the satisfaction of District. If Consultant has not cured the Default, District may hold all invoices and may choose to proceed with payment on said invoices only after the Default is cured to District's satisfaction. In the alternative, District may, in its sole discretion, during the period before Consultant has cured the Default, elect to pay any portion of outstanding invoices that corresponds to Services satisfactorily rendered. Any failure on the part of District to give notice of Consultant's default shall not be deemed to result in a waiver of District's legal rights or any rights arising out of any provision of this Agreement or the WAL.
 - a. In addition to District's termination rights set forth above, District shall have (i) the right to cure Consultant's Default at Consultant's cost, in which case all amounts expended by District in connection with such cure shall accrue interest from the date incurred until repaid to District by Consultant at the rate of ten percent (10%) per annum; and (ii) all other rights and remedies available to District at law and in equity, including, without limitation, an action for damages. District shall have the right to retain unpaid earned balances to offset damages, and/or charge Consultant for all damages above and beyond unpaid balance of WAL.
16. **Ownership of Documents.** All maps, models, designs, drawings, photographs, studies, surveys, reports, data, notes, computer files, files and other documents prepared, developed or discovered by Consultant in the course of providing any Services pursuant to this Agreement or the WAL (collectively and individually, the "Documents") shall become the sole property of District and may be used, reused or otherwise disposed of by District without the permission of Consultant. Upon completion, expiration or termination of this Agreement or the WAL, Consultant shall turn over to District all such Documents.
17. **Use of Documents by District.** If and to the extent that District utilizes for any purpose not related to this Agreement or the WAL any Documents, Consultant's guarantees and warranties related to Standard of Performance under this Agreement or the WAL shall not extend to such use of the Documents.
18. **Consultant's Books and Records.** Consultant shall maintain any and all documents and records demonstrating or relating to Consultant's performance of Services pursuant to this Agreement or the WAL for a minimum of four years after termination or expiration of this Agreement and the WAL, or longer if required by law. Such records shall include at minimum a detailed record of daily performance, staff time records, subconsultants time records, documentation of all costs incurred by Consultant that were billed to District, and detailed records of all Consultant fees, overhead, and profit on earned amounts.

a. Consultant shall maintain any and all ledgers, books of account, invoices, vouchers, canceled checks, or other documents or records evidencing or relating to work, services, expenditures and disbursements charged to District pursuant to this Agreement or the WAL for a minimum of four years, or longer if required by law, all in accordance with generally accepted accounting principles and with sufficient detail so as to permit an accurate evaluation of the Services provided by Consultant pursuant to this Agreement or the WAL.

b. Any and all such records or documents shall be made available for inspection, audit and copying, at any time during regular business hours, upon request by District or its designated representative. Copies of such documents or records shall be provided directly to District for inspection, audit and copying when it is practical to do so; otherwise, unless an alternative is mutually agreed upon, such documents and records shall be made available at Consultant's address indicated for receipt of notices in this Agreement.

c. District has the right to acquire custody of such records by written request if Consultant decides to dissolve or terminate its business. Consultant shall deliver or cause to be delivered all such records and documents to District within sixty (60) days of receipt of the request.

19. **Independent Contractor.** Consultant is retained as an independent contractor and is not employed by District. No employee or agent of Consultant shall become, or be considered to be, an employee of District for any purpose. It is agreed that District is interested only in the results obtained from the Services under this Agreement and the WAL and that Consultant shall perform as an independent contractor with sole control of the manner and means of performing the Services required under this Agreement and the WAL. Consultant shall complete this Agreement and the WAL according to its own methods of work which shall be in the exclusive charge and control of Consultant and which shall not be subject to control or supervision by District except as to results of the Services. Consultant shall provide all of its own supplies, equipment, facilities, materials, manpower, and any/all other resources that may become necessary in the course of completing the Services. It is expressly understood and agreed that Consultant and its employees shall in no event be entitled to any benefits to which District employees are entitled, including, but not limited to, overtime, retirement benefits, insurance, vacation, worker's compensation benefits, sick or injury leave or other benefits. Consultant will be responsible for payment of all of Consultant's employees' wages, payroll taxes, employee benefits and any amounts due for federal and state income taxes and Social Security taxes since these taxes will not be withheld from payments under this Agreement or the WAL.

a. The personnel performing the Services under this Agreement and the WAL on behalf of Consultant shall at all times be under Consultant's exclusive direction and control. Consultant, its agents or employees shall not at any time or in any manner represent that Consultant or any of Consultant's officers, employees, or agents are in any manner officials, officers, employees or agents of District.

b. Consultant shall have no authority to bind District in any manner, or to incur any obligation, debt or liability of any kind on behalf of or against District, whether by contract or otherwise, unless such authority is expressly conferred in writing by District, or under this Agreement.

20. **Standard of Performance.** Consultant represents and warrants that it has the skill, qualifications, experience and facilities necessary to properly perform the Services required under this Agreement and the WAL in a thorough, competent and professional manner. Consultant represents and warrants that its employees and subcontractors have all legally required licenses, permits, qualifications and approvals necessary to perform the Services and that all such licenses and approvals shall be maintained throughout the term of this Agreement and the WAL. Consultant shall at all times faithfully, competently and to the best of its ability, experience and talent, perform all Services

described herein and the WAL. In meeting its obligations under this Agreement and the WAL, Consultant shall employ, at a minimum, the standard of care utilized by persons engaged in providing services similar to those required of Consultant under this Agreement and the WAL for California school districts in or around the same geographic area of District (the “Standard of Performance”).

21. **Confidential Information.** All information gained during performance of the Services and all Documents or other work product produced by Consultant in performance of this Agreement and the WAL shall be considered confidential (“confidential information”). Consultant shall not release or disclose any such confidential information, Documents or work product to persons or entities other than District without prior written authorization from the Superintendent of District and/or Program Manager, except as may be required by law. Confidential information does not include information that: (i) Consultant had in its possession prior to considering entering into this Agreement; (ii) becomes public knowledge through no fault of Consultant; (iii) Consultant lawfully acquires from a third party not under an obligation of confidentiality to the disclosing party; or (iv) is independently developed by Consultant without benefit of the information provided by District. In connection with confidential information:

a. Consultant shall promptly notify District if it is served with any summons, complaint, subpoena or other discovery request, court order or other request from any party regarding this Agreement or the WAL or the Services performed hereunder or the WAL.

b. District retains the right, but has no obligation, to represent Consultant or be present at any deposition, hearing or similar proceeding. Consultant agrees to cooperate fully with District and to provide District with the opportunity to review any response to discovery requests provided by Consultant; provided that this does not imply or mean the right by District to control, direct, or rewrite said response.

22. **Conflict of Interest; Disclosure of Interest.** Consultant covenants that neither it, nor any officer or principal of its firm, has or shall acquire any interest, directly or indirectly, which would conflict in any manner with the interests of District or which would in any way hinder Consultant’s performance of the Services under this Agreement or the WAL. Consultant further covenants that in the performance of this Agreement and the WAL, no person having any such interest shall be employed by it as an officer, employee, agent or subcontractor without the express written consent of District. Consultant agrees to at all times avoid conflicts of interest or the appearance of any conflicts of interest with the interests of District in the performance of this Agreement and the WAL.

a. Bylaws of the Board 2030(A) E, 2030(B) E and 2030(C) E, as hereinafter amended or renumbered, require that a consultant that qualifies as a “designated employee” must disclose certain financial interests by filing financial interest disclosures. By its initials below, Consultant (i) represents that it has received and reviewed a copy of the Bylaws of the Board 2030(A) E, 2030(B) E and 2030(C) E and that it does does not qualify as a “designated employee”; and (ii) agrees to notify District, in writing, if Consultant believes that it is a “designate employee” and should be filing financial interest disclosures, but has not been previously required to do so by District.

 (Initials)

23. **Compliance with Applicable Laws.** In connection with the Services and its operations, Consultant shall keep itself informed of and comply with all applicable federal, state and local laws, statutes, codes, ordinances, regulations and rules including, but not limited to, minimum wages and/or prohibitions against discrimination, in effect during the Term. Consultant shall obtain any and all licenses, permits and authorizations necessary to perform the Services. Neither District, nor any

elected or appointed boards, officers, officials, employees or agents of District shall be liable, at law or in equity, as a result of any failure of Consultant to comply with this section.

a. Without limiting the generality of the foregoing, Consultant, unless exempted, shall comply with the requirements of Education Code Section 45125.1 with respect to fingerprinting of employees who may have contact with District's pupils. Consultant must complete District's certification form, attached herein as Exhibit E, prior to any of Consultant's employees coming into contact with any of District's pupils. Consultant also agrees to comply with all other operational requirements of District, as may be revised from time to time, including but not limited to any obligations relating to vaccination or testing for infectious diseases.

 (Initials)

24. **Unauthorized Aliens.** Consultant hereby promises and agrees to comply with all of the provisions of the Federal Immigration and Nationality Act, 8 U.S.C.A. §§ 1101, et seq., as amended, and in connection therewith, shall not employ "unauthorized aliens" as that term is defined in 8 U.S.C.A. §1324a(h)(3). Should Consultant so employ such individuals for the performance of work and/or Services covered by this Agreement or the WAL, and should any liability or sanctions be imposed against District for such employment, Consultant hereby agrees to and shall reimburse District for the cost of all such liabilities or sanctions imposed, together with any and all costs, including attorneys' fees, incurred by District.
25. **Non-Discrimination.** Consultant shall abide by the applicable provisions of the United States Civil Rights Act of 1964 and other provisions of law prohibiting discrimination and shall not discriminate, in any way, against any person on the basis of race, color, religious creed, national origin, ancestry, sex, sexual orientation, age, physical handicap, medical condition or marital status in connection with or related to the performance of this Agreement or the WAL.
26. **Disabled Veteran Business Enterprise Participation.** Pursuant to Education Code section 17076.11, District has a participation goal for disabled veteran business enterprises (DVBES) of at least three (3) percent, per year, of funds expended each year by District on projects that use funds allocated by the State Allocation Board pursuant to the Leroy F. Greene School Facilities Act. Unless waived in writing by District, Consultant shall provide proof of DVBE compliance, in accordance with any applicable policies of District or the State Allocation Board, within thirty (30) days of its execution of this Agreement
27. **Assignment.** The expertise and experience of Consultant are material considerations for this Agreement and the WAL. District has an interest in the qualifications of and capability of the persons and entities that will fulfill the duties and obligations imposed upon Consultant under this Agreement and the WAL. In recognition of that interest, Consultant shall not assign or transfer this Agreement or any portion of this Agreement or any portion of the WAL or the performance of any of Consultant's duties, Services or obligations under this Agreement or the WAL without the prior written consent of District and approved by District's Board of Trustees. Any attempted assignment shall be ineffective, null and void, and shall constitute a material breach of this Agreement and the WAL entitling District to any and all remedies at law or in equity, including summary termination of this Agreement and the WAL.
28. **Subcontracting.** Notwithstanding the above, Consultant may utilize subcontractors in the performance of its duties pursuant to this Agreement and the WAL, but only with the prior written consent of District. Consultant shall be as fully responsible to District for the acts and omissions of its subcontractors, and of persons either directly or indirectly employed by Consultant's subcontractors, as if the acts and omissions were performed by Consultant directly.

29. **District Administrator.** **Lisa Franz** shall be in charge of administering this Agreement on behalf of District, (the “Administrator”) provided that any written notice or any consent, waiver or approval of District must be signed by the Superintendent or a designated employee of District to be valid. The Administrator has completed **Exhibit D** “Conflict of Interest Check” attached hereto.

30. **Continuity of Personnel.** Consultant shall make every reasonable effort to maintain the stability and continuity of Consultant’s staff and subcontractors consistent with the staff proposed as part of the Statement of Qualifications, if any, assigned to perform Services under this Agreement and the WAL.

a. Consultant shall provide District and the Administrator a list of all personnel and subcontractors providing Services and shall maintain said list current and up to date at all times during the Term. The list shall include the following information: (1) all full or part-time staff positions by title, including volunteer positions whose direct services are required to provide the Services; (2) a brief description of the functions of each such position and the hours each position works each week or, for part-time positions, each day or month, as appropriate; (3) the professional degree, if applicable, and experience required for each position; and (4) the name of the person responsible for fulfilling the terms of this Agreement and the WAL.

31. **Indemnification.** To the fullest extent permitted by law, Consultant shall defend and indemnify District and its officials, elected board members, employees and agents (“Indemnified Parties”) from and against all claims that arise out of, pertain to, or relate to the negligence, recklessness, or willful misconduct of the Consultant, its officers, employees, consultants, subcontractors, or agents, pursuant to this Agreement and/or the WAL, but not for any loss, injury, death or damage caused by the active negligence or willful misconduct of any of the Indemnified Parties.

a. Consultant agrees to obtain executed indemnity agreements with provisions identical to the above from each and every subcontractor retained or employed by Consultant in the performance of this Agreement and the WAL. Failure of District to monitor compliance with these requirements imposes no additional obligations on District and will in no way act as a waiver of any rights hereunder. Consultant’s obligation to indemnify and defend District as set forth above is binding on the successors, assigns or heirs of Consultant and shall survive the termination of this Agreement and the WAL.

 (Initials)

32. **Insurance.** Consultant agrees to obtain and maintain in full force and effect during the term of this Agreement the insurance policies set forth in **Exhibit C** “Insurance” and made a part of this Agreement. All insurance policies shall be subject to approval by District as to form and content. These requirements are subject to amendment or waiver if so approved in writing by the District Superintendent.

33. **Notices.** All notices required or permitted to be given under this Agreement or the WAL shall be in writing and shall be personally delivered, or sent by telecopier or certified mail, postage prepaid and return receipt requested, addressed as follows:

To District: Oxnard School District
1051 South A Street
Oxnard, California, 93030
Attention: Lisa Cline
Assistant Superintendent, Business & Fiscal Services
Re: [Insert Project Name]

With electronic copy to: Caldwell Flores Winters, Inc.
Oxnard School District Program Manager
6425 Christie Ave., Suite 270
Emeryville, California 94608
Attention: Yuri Calderon
T: 510-596-8170
Email: ycalderon@cfwinc.com

To Consultant: Cardno ATC
25 Cupania Circle
Monterey Park, CA 91755
ATTN: Carlos A. Galdamez
T: (323) 517-9780
Email: carlos.galdamez@cardno.com

All notices, demands, or requests to be given under this Agreement or the WAL shall be given in writing and conclusively shall be deemed received when delivered in any of the following ways: (i) on the date delivered if delivered personally; (ii) on the date sent if sent by facsimile transmission and confirmation of transmission is received; (iii) on the date it is accepted or rejected if sent by certified mail; and (iv) the date it is received if sent by regular United States mail.

34. **Excusable Delays.** Neither Party will be liable to the other for unanticipated delays or failures in performance resulting from causes beyond the reasonable control of that Party, including, but not limited to, acts of God, labor disputes or disturbances, material shortages or rationing, riots, acts of war, governmental regulations, communications or utility failures, or casualties; provided that the delayed Party: (i) gives the other Party prompt written notice of such cause; and (ii) uses its reasonable efforts to correct such failure or delay in its performance. The delayed Party's time for performance or cure under this section will be extended for a period equal to the duration of the cause or sixty (60) days, whichever is less.
35. **Entire Agreement; Binding Effect.** This Agreement including Exhibits hereto, contains the entire understanding of the Parties, and supersedes all other written or oral agreements. Consultant shall be entitled to no other benefits other than those specified herein. No changes, amendments or alternations shall be effective unless in writing and signed by both Parties and approved by District's Board of Trustees. Consultant specifically acknowledges that in entering into this Agreement, Consultant relied solely upon the provisions contained in this Agreement and no others. This Agreement shall be binding upon the heirs, executors, administrators, successors and assigns of the Parties.
36. **Amendment.** No changes, amendments to or modifications of this Agreement or the WAL shall be valid, effective or binding unless made in writing and signed by both Parties and approved by the District's Board of Trustees. The Parties agree that this requirement for written modifications cannot be waived and that any attempted waiver shall be void.
37. **Waiver.** Waiver by any Party of any term, condition, or covenant of this Agreement or the WAL shall not constitute a waiver of any other term, condition, or covenant. Waiver by any Party of any breach of the provisions of this Agreement or the WAL shall not constitute a waiver of any other provision or a waiver of any subsequent breach or violation of any provision of this Agreement or the WAL. None of the provisions of this Agreement or the WAL shall be considered waived by either Party unless such waiver is specifically specified in writing. Neither District's review, approval of, nor payment for, any of the Services required under this Agreement or the WAL shall be construed to operate as a waiver of

any rights under this Agreement or the WAL, and Consultant shall remain liable to District in accordance with this Agreement and the WAL for all damages to District caused by Consultant's failure to perform any of the Services to the Standard of Performance. This provision shall survive the termination of this Agreement and the WAL.

- 38. **Governing Law.** This Agreement and the WAL shall be interpreted, construed and governed according to the laws of the State of California. With respect to litigation involving this Agreement, the WAL or the Services, venue in state trial courts shall lie exclusively in the County of Ventura, California.
- 39. **Severability.** If any term, condition or covenant of this Agreement or the WAL is declared or determined by any court of competent jurisdiction to be invalid, void or unenforceable, the remaining provisions of this Agreement and the WAL shall not be affected thereby and the Agreement and WAL shall be read and construed without the invalid, void or unenforceable provision(s).
- 40. **Authority to Execute.** The person or persons executing this Agreement on behalf of Consultant represents and warrants that he/she/they has/have the authority to so execute this Agreement and to bind Consultant to the performance of its obligations hereunder.

IN WITNESS WHEREOF, District and Consultant have executed and delivered this Agreement for consultant services as of the date first written above.

OXNARD SCHOOL DISTRICT:

CARDNO ATC:

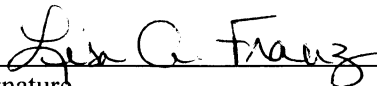
Signature

Signature

Lisa A. Franz, Director, Purchasing
Typed Name/Title

Stephen Drengson/Program Manager
Typed Name/Title

11-20-13
Date

10/30/13
Date

Tax Identification Number: 95-6002318

Tax Identification Number: 46-0399408

Not Project Related

Project #13-135

EXHIBIT A
TO AGREEMENT FOR CONSULTANT SERVICES #13-135

WORK AUTHORIZATION PROCEDURES

1. Assignment of Work Authorization

- 1.1. Request For Proposal (RFP): At the sole discretion of District, one or more prequalified professional services consultants shall be solicited with a Request For Proposal (“RFP”) for a specific lump sum fixed fee proposal for defined Services to be complete within a defined timeline. For a proposal to be valid it must clearly acknowledge the complete Services requested by District and must include a lump sum fixed fee amount to complete all defined Services, a clearly defined schedule for completion of Services which meets the required timeline defined by District and shows final completion to occur within the Term of this Agreement.
- 1.2. Evaluation of Proposal: District’s Program Manager, in consultation with District, shall review each proposal for validity, accuracy, competitiveness, and overall quality of the Services proposed to be performed. In the case where more than one firm is solicited for a scope of defined Services, the Program Manager shall evaluate each proposal thoroughly based on predetermined, objective criteria to ensure a just and fair review of all proposals.
- 1.3. Selection of Consultant: Following evaluation of proposals, the consultant whose proposal exhibits the best value for the benefit of District shall be recommended to the Superintendent for approval.
- 1.4. Work Authorization Letter (WAL): With the approval of the District Superintendent, the Program Manager shall issue a Work Authorization Letter (“WAL”) to the selected consultant to perform the defined Services as indicated in the RFP, for the lump sum fixed fee amount reflected in the proposal, with all Services to complete within the timeline indicated in the RFP, and the Term set forth in this Agreement. District retains the right to negotiate all terms of the WAL subsequent to the receipt of proposal(s) in order to clarify the scope of Services, and/or make any adjustments to the fee amount and required schedule prior to issuance of the WAL. The WAL shall be considered a binding agreement, and amendment to this Agreement, once executed by Consultant, approved by the District Board of Trustees, and executed by the Superintendent.
- 1.5. Performance of Services Set Forth in the WAL: Performance of Services set forth in the WAL shall not commence until final approval by the District Superintendent and Board of Trustees, unless expressly authorized by the District Superintendent and Program Manager. During the course of completing the Services, Consultant shall comply will all provisions of this Agreement and the WAL. All Services set forth in the WAL shall be completed within the schedule set forth in the WAL.
- 1.6. Close Out of WAL Services: Upon completion of all Services required by the WAL, Consultant shall submit all required close-out documentation, certifications, records, reports, warranties, and any other information required or requested by District prior to submitting Consultant’s invoice for final payment.
- 1.7. WAL Form: See next page for sample Work Authorization Letter.

Not Project Related

Project #13-135

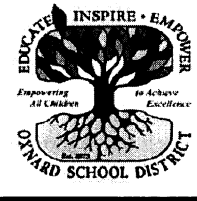
|  | | WORK AUTHORIZATION LETTER (WAL) | |
|--|--|--|--------|
| GENERAL INFORMATION | | | |
| PROJECT #: | | DATE: | |
| SITE NAME: | | DSA #: | |
| MASTER AGREEMENT #: | | OPSC #: | |
| WAL #: | | VENDOR ID: | |
| PURSUANT TO MASTER AGREEMENT BETWEEN: | | | |
| DISTRICT | | CONSULTANT | |
| OXNARD SCHOOL DISTRICT 1051 South A. St. Oxnard , CA 93030 (805) 385-1501 | | Firm Name: Street: City, State, Zip: Phone: | |
| SCOPE OF SERVICES TO BE PERFORMED UNDER THIS WAL | | | |
| (ATTACH ADD'L PAGES AS NECESSARY) | | | |
| SCHEDULE OF SERVICES TO BE PERFORMED UNDER THIS WAL | | | |
| START DATE: | | COMPLETION DATE: | |
| FIXED FEE AMOUNT: _____ | | | |
| <i>This fee amount is based upon Consultant's proposal dated _____, and subsequent negotiations mutually agreed to by all parties.</i> | | | |
| <i>This WAL is inherently a part of the Master Agreement indicated above. It is bound by the general terms and conditions of the Master Agreement. This WAL describes in detail the Consultants specific scope of Services, agreed upon lump sum fixed fee, agreed upon schedule for completion of Services, and other provisions required to clearly indicate the required Services, and terms of this WAL.</i> | | | |
| <i>This WAL and associated Master Agreement hereby supersede any and all terms, conditions, and other provisions of the Consultant's proposal, and such terms, conditions, and other provisions are null and void and are not incorporated to any extent as part of this WAL and associated Master Agreement whether or not they are directly superseded by this WAL and/or the associated Master Agreement.</i> | | | |
| IN WITNESS THEREOF, THE PARTIES HAVE AGREED TO AND EXECUTED THIS WAL AS SET FORTH BELOW: | | | |
| DISTRICT | | CONSULTANT | |
| OXNARD SCHOOL DISTRICT | | CONSULTANT: | |
| (SIGNATURE) | (DATE) | (SIGNATURE) | (DATE) |
| FOR DISTRICT USE ONLY | | | |
| PROJECT MANAGER: | | PREPARED BY: | |
| PO #: | | PO AMOUNT: | |
| SOURCE OF FUNDS: | <input type="checkbox"/> MEASURE "R" <input type="checkbox"/> DEF. MAINT. <input type="checkbox"/> DEV. FEES <input type="checkbox"/> OTHER: _____ | | |
| COST ID: | | | |
| (PM APPROVAL SIGNATURE) | | (DATE) | |
| SPECIAL INSTRUCTIONS: | | | |

Not Project Related

Project #13-135

EXHIBIT B
TO AGREEMENT FOR CONSULTANT SERVICES #13-135

COMPENSATION & RATE/FEE SCHEDULE

I. The following rates of pay shall apply in the performance of the Services under this Agreement and the WAL:

STANDARD PERSONNEL RATES

| Category | Base Hourly Rates |
|---|--------------------------|
| Principal | \$115.00 |
| Certified Safety Professional (CSP) | \$115.00 |
| Certified Industrial Hygienist (CIH) | \$125.00 |
| Geologist (CA Registered) | \$95.00 |
| Engineer (CA Registered) | \$95.00 |
| Program Manager | \$95.00 |
| Senior Project Manager | \$85.00 |
| Senior Engineer | \$85.00 |
| Senior Geologist | \$85.00 |
| Senior Industrial Hygienist | \$90.00 |
| Project Industrial Hygienist | \$75.00 |
| Project Engineer | \$75.00 |
| Project Geologist | \$75.00 |
| Project Scientist | \$75.00 |
| Certified Asbestos Consultant (CA DOSH) | \$75.00 |
| Project Manager | \$75.00 |
| Trainer | \$75.00 |
| Staff Industrial Hygienist | \$65.00 |
| Staff Engineer | \$65.00 |
| Staff Geologist | \$65.00 |
| Certified Lead Project Designer (CA Registered) | \$55.00 |
| Certified Lead Inspector/Assessor (CA Registered) | \$55.00 |
| Certified Lead Project Monitor (CA Registered) | \$55.00 |
| Certified Site Surveillance Technician (CA DOSH) | \$55.00 |
| Technician III | \$65.00 |
| Technician II | \$55.00 |
| Technician I | \$45.00 |
| Draftsperson / CADD | \$45.00 |
| Clerical Staff | \$35.00 |

Not Project Related

Project #13-135

ASBESTOS

| PLM Analysis (NVLAP QA/QC) 600/R-93/116 | | PCM Analysis NIOSH 7400, Revision 3 A Rules | | TEM Air Analysis AHERA/EPA Level II | |
|---|---------|---|---------|--|----------|
| Immediate | \$20.00 | Immediate | \$20.00 | Immediate | \$140.00 |
| 8 hours | \$15.00 | 8 hours | \$15.00 | 8 hours | \$125.00 |
| 24 hours | \$12.00 | 24 hours | \$12.00 | 24 hours | \$100.00 |
| 48 hours | \$9.00 | 48 hours | \$9.00 | 48 hours | \$75.00 |
| 3-5 days | \$9.00 | 3-5 days | \$9.00 | 3-5 days | \$75.00 |

| 1000 Point Count Analysis (0.1% Limit of Detection) | | Wipes/Microvac by TEM Chatfield Method Semi- Quantitative | | Wipes/Microvac by TEM ASTM D- 5755 Quantitative | |
|--|----------|---|----------|--|-------|
| Immediate | N/A | Immediate | \$200.00 | Immediate | N/A |
| 8 hours | N/A | 8 hours | \$175.00 | 8 hours | N/A |
| 24 hours | N/A | 24 hours | \$175.00 | 24 hours | N/A |
| 48 hours | N/A | 48 hours | \$125.00 | 48 hours | N/A |
| 3-5 days | \$100.00 | 3-5 days | \$125.00 | 5 days | \$200 |

LEAD

| Paint, Dust, Soil, Wipe, Bulk Sample Analysis EPA 3050/7420 Air, Wipes NIOSH 7082 | | Drinking Water Analysis EPA 200.9 | | Waste Analysis Extraction Only | | | |
|--|---------|--------------------------------------|---------|-----------------------------------|----------|------------------|----------|
| | | | | STLC Wet-Title 22 | | TCLP EPA 1311 | |
| Immediate | \$32.00 | Immediate | \$40.00 | 24 hours | N/A | 24-hours | \$125.00 |
| 8 hours | \$28.00 | 8 hours | \$35.00 | 2 days | \$100.00 | 2 days | \$100.00 |
| 24 hours | \$17.00 | 24 hours | \$30.00 | 3-5 days | \$84.00 | 3-5 days | \$84.00 |
| 48 hours | \$14.00 | 48 hours | \$25.00 | | | | |
| 3-5 Days | \$10.00 | 3-5 Days | \$20.00 | | | | |

Not Project Related

Project #13-135

II. Consultant may utilize subcontractors as permitted in the Agreement and the WAL. The hourly rate for any subcontractor shall be consistent with the rate and fee schedule indicated in Section I above, unless other direction is provided with written authorization from District Superintendent or his/her designee.

III. Claims for reimbursable expenses shall be documented by appropriate invoices and supporting receipts. Consultant may be reimbursed for those reasonable out-of-pocket expenses set forth below that are incurred and paid for by Consultant beyond the typical obligations under this Agreement and the WAL, but only to the extent that such expenses are directly related to Services satisfactorily completed, are approved by District in writing and do not cause the amounts paid to Consultant to exceed the amounts allowed under this Agreement and the WAL. No mark-up of any expense is permitted. The following is the EXCLUSIVE list of reimbursable expenses:

A. Travel and Mileage. Consultant must request the travel in writing and justify why the travel should be reimbursed. Travel expenses must be approved in writing by District, in its sole discretion. Trips from any Consultant's office to District's office or to the subject project site will not be approved for reimbursement.

B. Reimbursable Reprographic Services. Print sets or copies requested in writing by District beyond the quantities required under the WAL.

C. Fees for Subcontractors. Fees for subcontractors hired and paid by Consultant at the written request of District and are permitted in the Agreement and the WAL.

D. Fees advanced for securing approval of public agencies having jurisdiction over any project hereunder.

IV. Consultant shall provide to District a complete Schedule of Values (SOV), identifying major work activities required to complete the authorized scope of work. All invoices must reflect the appropriate progress percentage for each SOV item billed, to be verified by District. District will compensate Consultant for the Services performed upon approval by District of a valid and complete invoice, in form and substance acceptable to District. See Exhibit G for required Invoice Approval Form and Billing Cover Sheet. The Billing Cover Sheet shall reflect the approved SOV. In connection with Services that are only partially completed at the time an invoice is paid, notwithstanding any provision of the Agreement, the WAL, or any other document, payment of the invoice does not constitute acceptance of the partially completed work or Service. Each invoice is to include:

A. Billing Cover Sheet/SOV with all appropriate progress percentages identified toward completion of the Services.

B. Acceptable back-up for billings shall include, but not be limited to:

a. Records for all personnel describing the work performed, the number of hours worked, and the hourly rate, for all time charged to the Services.

b. Records for all supplies, materials and equipment properly charged to the Services.

c. Records for all travel pre-approved by District and properly charged to the Services.

d. Records for all subcontractor labor, supplies, equipment, materials, and travel properly charged to the Services.

Unless otherwise directed by District, in writing, completed invoices are to be submitted to the attention of the Director of Purchasing and the Assistant Superintendent, Business and Fiscal Services. To be considered complete,

Not Project Related

Project #13-135

the invoice packet shall include all back-up documentation required by District and sign-off from District staff, Program Manager or project manager assigned by District to supervise the Services.

V. The total compensation for the Services shall be provided for in the WAL(s) issued subsequent to this Agreement.

VI. Compensation Upon Termination. In the event that District suspends or terminates this Agreement, the WAL or any of the Services pursuant to Section 11 or Section 12a of the Agreement, District will pay Consultant as provided herein and the WAL for all Services and authorized Additional Work actually performed, and all authorized reimbursable expenses actually incurred and paid, under and in accordance with this Agreement and the WAL, up to and including the date of suspension or termination; provided that such payments shall not exceed the amounts specified in the Agreement and the WAL as compensation for the Services completed, plus any authorized Additional Work and authorized reimbursable expenses completed prior to suspension or termination. No payment for demobilization shall be paid unless District at its sole discretion determines that demobilization or other compensation is appropriate. After a notice of termination is given, Consultant shall submit to District a final claim for payment, in the form and with certifications prescribed by District. Such claim shall be submitted promptly, but in no event later than forty (40) calendar days after the Termination Date specified on the notice of termination. Such payment shall be Consultant's sole and exclusive compensation and District shall have no liability to Consultant for any other compensation or damages, including without limitation, anticipated profit, prospective losses, legal fees or costs associated with legal representation or consequential damages, of any kind.

- Not Project Related
- Project #13-135

EXHIBIT C
TO AGREEMENT FOR CONSULTANT SERVICES #13-135

INSURANCE

I. **Insurance Requirements.** Consultant shall provide and maintain insurance, acceptable to District Superintendent or District Counsel, in full force and effect throughout the Term of this Agreement and the WAL, against claims for injuries to persons or damages to property which may arise from or in connection with the performance of the work hereunder by Consultant, its agents, subcontractors, representatives and/or employees. Insurance is to be placed with insurers authorized to conduct business in the State of California and with a current A.M. Best's rating of no less than A, as rated by the current edition of Best's Key Rating Guide, published by A.M. Best Company, Oldwick, New Jersey 08858. Consultant shall provide the following scope and limits of insurance:

A. **Minimum Scope of Insurance.** Coverage shall be at least as broad as:

- (1) Commercial General Liability coverage of not less than two million dollars (\$2,000,000) aggregate and one million dollars (\$1,000,000) per occurrence.
- (2) Auto liability insurance with limits of not less than one million dollars (\$1,000,000).
- (3) Insurance coverage should include:
 - 1. owned, non-owned and hired vehicles;
 - 2. blanket contractual;
 - 3. broad form property damage;
 - 4. products/completed operations; and
 - 5. personal injury.
- (4) Workers' Compensation insurance as required by the laws of the State of California.
- (5) Abuse and Molestation coverage of not less than two million dollars (\$2,000,000) per occurrence and five million dollars (\$5,000,000) aggregate.
- (6) Professional liability (Errors and Omissions) insurance, including contractual liability, as appropriate to the Consultant's profession, in an amount of not less than the following:

| | |
|--|----------------------------|
| Accountants, Attorneys, Education Consultants, Nurses, Therapists | \$1,000,000 |
| Architects | \$1,000,000 or \$2,000,000 |
| Physicians and Medical Corporations | \$5,000,000 |

Failure to maintain professional liability insurance is a material breach of this Agreement and the WAL and grounds for immediate termination

II. **Other Provisions.** Insurance policies required by this Agreement shall contain the following provisions:

Not Project Related

Project #13-135

A. All Policies. Each insurance policy required by this Agreement shall be endorsed and state the coverage shall not be suspended, voided, cancelled by the insurer or either Party to this Agreement, reduced in coverage or in limits except after 30 days' prior written notice by Certified mail, return receipt requested, has been given to District

B. General Liability, Automobile Liability, and Abuse/Molestation Coverages.

(1) District, and its respective elected and appointed officers, officials, employees and volunteers are to be covered as additional insureds (collectively, "additional insureds") as respects the following: liability arising out of activities and/or Services Consultant performs; products and completed operations of Consultant; premises owned, occupied or used by Consultant; automobiles owned, leased, hired or borrowed by Consultant, and Abuse/Molestation. The coverage shall contain no special limitations on the scope of protection afforded to additional insureds.

(2) Each policy shall state that the coverage provided is primary and any insurance carried by any additional insured is in excess to and non-contributory with Consultant's insurance.

(3) Consultant's insurance shall apply separately to each insured against whom claim is made or suit is brought, except with respect to the limits of the insurer's liability.

(4) Any failure to comply with the reporting or other provisions of the policies including breaches of warranties shall not affect coverage provided to any additional insured.

III. Other Requirements. Consultant agrees to deposit with District, at or before the effective date of this Agreement and the WAL, certificates of insurance necessary to satisfy District that the insurance provisions of this Agreement have been complied with. District may require that Consultant furnish District with copies of original endorsements effecting coverage required by this section. The certificates and endorsements are to be signed by a person authorized by that insurer to bind coverage on its behalf. District reserves the right to inspect complete, certified copies of all required insurance policies, at any time.

A. If any Services are performed by a subcontractor, Consultant shall furnish certificates and endorsements from each subcontractor identical to those Consultant provides.

B. Any deductibles or self-insured retentions must be declared to and approved by District. At the option of District, either the insurer shall reduce or eliminate such deductibles or self-insured retentions as respects District or its respective elected or appointed officers, officials, employees and volunteers or the Consultant shall procure a bond guaranteeing payment of losses and related investigations, claim administration, defense expenses and claims.

C. The procuring of any required policy or policies of insurance shall not be construed to limit Consultant's liability hereunder nor to fulfill the indemnification provisions and requirements of this Agreement.

Not Project Related

Project #13-135

EXHIBIT D
TO AGREEMENT FOR CONSULTANT SERVICES #13-135

CONFLICT OF INTEREST CHECK

Bylaws of the Board 2030(C)E requires that the Superintendent or a designee make a determination, on a case by case basis, concerning whether disclosure will be required from a consultant to comply with District's Conflict of Interest Code (commencing with Bylaws of the Board 2030 BB).

Consultants are required to file disclosures when, pursuant to a contract with District, Consultant will make certain specified government decisions or will perform the same or substantially the same duties for District as a staff person would.

The services to be performed by Consultant under the Agreement to which this Exhibit D is attached constitute do not constitute governmental decisions or staff services within the meaning of the Conflict of Interest Code. Therefore, Consultant, is is not subject to disclosure obligations.

Date: 11-20-13

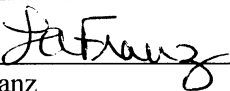
By: 
Lisa A. Franz
Director, Purchasing

Not Project Related

Project #13-135

**EXHIBIT “E”
TO AGREEMENT FOR CONSULTANT SERVICES #13-135**

**BACKGROUND CHECK AND FINGERPRINTING PROCEDURES
FOR CONTRACTORS**

The successful Bidder will be required to assure that its employees, subcontractors of any tier, material suppliers, and consultants do not have direct contact with the District’s students during the performance of the Contract in compliance with Education Code §§ 45125.1 and 45125.2. To assure these provisions, the successful Bidder’s supervisor shall be fingerprinted, and proof of same shall be provided to the District prior to start of on-site work. The supervisor will monitor the workers’ conduct while on school grounds. In addition, the successful Bidder shall barricade the Work area to separate its workers from the students. Costs associated with this process are the responsibility of the successful Bidder.

The Contractors’ construction supervisors or their unsupervised employees who will be working outside of fenced areas during the school hours **must** have submitted a fingerprint identification card to the Department of Justice (DOJ) and have a proof of clearance in the form of an affidavit filed in the Oxnard School District’s Purchasing Office **prior to** the start of the Work.

California Education Code §§45125.1 and 45125.2 require that criminal checks be completed for contractors (Contracting Firm) who provide architectural, construction, janitorial, administrative, landscape, transportation, food-related, or other similar services to school districts.

The undersigned does hereby certify to the Board of Trustees of the Oxnard School District as follows:

That I am a representative of the Contractor currently under contract (“Contract”) with the District; that I am familiar with the facts herein certified, and am authorized and qualified to execute this certificate on behalf of Contractor.

Contractor certifies that it has taken the following actions with respect to the construction Project that is the subject of the Contract:

1. Pursuant to Education Code §45125.2, Contractor has installed or will install, prior to commencement of Work, a physical barrier at the Work Site, which will limit contact between Contractor’s employees and District pupils at all times (mandatory for all Projects); AND
2. The Contractor has complied with the fingerprinting requirements of Education Code §45125.1 with respect to all Contractor’s employees and all of its subcontractors’ employees who may have contact with District pupils in the course of providing services pursuant to the Contract, and the California Department of Justice has determined that none of those employees has been convicted of a felony, as that term is defined in Education Code §45122.1. A complete and accurate list of Contractor’s employees and of all its subcontractors’ employees who may come in contact with District pupils during the course and scope of the Contract is attached hereto; AND/OR

Not Project Related

Project #13-135

3. Pursuant to Education Code §45125.2, Contractor certifies that all employees will be under the continual supervision of, and monitored by, an employee of the Contractor who the California Department of Justice has ascertained has not been convicted of a violent or serious felony. The name and title of each employee who will be supervising Contractor's employees and its subcontractors' employees is:

Name: SEE LIST BELOW - ALL CLEARED

Title: _____

AND/OR

4. The Work on the Contract is at an unoccupied school site and no employee and/or subcontractor or supplier of any tier of Contract shall come in contact with District pupils.

Contractor's responsibility for background clearance extends to all of its employees, Subcontractors, and employees of Subcontractors coming into contact with District pupils regardless of whether they are designated as employees or acting as independent contractors of the Contractor.

Date: 10/30/13

Proper Name of Contractor: ATC GROUP SERVICES INC dba CARONO ATC

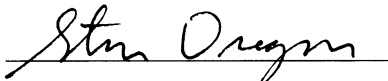
Signature: 

By: STEPHEN DRENSON

Its: PROGRAM MANAGER

PRINTS ON FILE & CLEARED:

STEPHEN DRENSON SR PM
CARLOS GALDAMEZ SA PM
BARRY HIETT SA PM
ROBERT de la TORRE TECH
DAMON CARRIER TECH
RICHARD GARCIA TECH

Not Project Related

Project #13-135

**EXHIBIT “F”
TO AGREEMENT FOR CONSULTANT SERVICES #13-135**

SCOPE OF SERVICES – Lead, Asbestos, & Hazardous Materials Survey & Testing

The Lead, Asbestos, & Hazardous Materials Survey & Testing Lab’s Scope of Work includes, but is not limited to, the following:

Consultant shall ensure that the project sites and existing improvements are free from hazardous materials, and/or to verify the presence of hazardous materials and develop a work plan to remove, contain, or otherwise mitigate the effects of hazardous materials to the school site. All work by this consultant must be performed in accordance with Division of State Architect (DSA), California Department of Education (CDE), California Department of Toxic Substances Control (DTSC), California Environmental Quality Act (CEQA), California Occupational Safety and Health Administration (Cal-OSHA), and all other agencies having jurisdiction.

1. Pre-Construction Services:

a. Asbestos-Related Consulting Services

- i. Provide State of California, Division of Occupational Safety and Health Association (OSHA), Certified Asbestos Consultant(s) (CAC) or Certified Site Surveillance Technician(s) (CSST), for asbestos-related services.
- ii. Review sites and scope of work and/or specification and plans for proposed construction activities to determine the type of work that will occur on the project. Also, CONSULTANT shall review building records, including architectural and structural plans as provided by the DISTRICT to obtain information regarding building elements and for reference to asbestos used in construction, renovation and/or repair.
- iii. Meet with District Project Manager and where applicable, other consultants, to perform on-site inspections of the locations involved in the project to determine where asbestos containing materials may be present, or are in close proximity to the work and could be impacted, as a result of the project.
- iv. Review of previous asbestos documents provided by the DISTRICT to determine sampling strategy. Sampling to be conducted in accordance with EPA/AHERA established sampling protocols and asbestos analysis shall be performed by an NVLAP Accredited Laboratory.
- v. Inspections shall include accessing and possibly creating destructive entry into walls and enclosed spaces. CONSULTANT shall collect representative bulk samples of suspect materials not identified as positive or negative for asbestos content. Materials assumed to contain asbestos, such as transite pipes and flues, gaskets, etc. will not be sampled or analyzed.
- vi. Take digital photographs of special site conditions, anomalies, and for describing conditions more clearly.
- vii. Review existing Asbestos Management Plan, Survey Reports and supplemental bulk sample and analysis reports and reports prepared by consultants on prior projects.

b. Lead Based Paint (LBP) and other Lead-Related Consulting Services

- i. Provide staff with State of California, Department of Health Services Lead Certification to perform lead-related services.

Not Project Related

Project #13-135

- ii. Review sites and scope of work and/or specification and plans for proposed construction activities to determine the type of work that will occur on the project.
- iii. Meet with District Project Manager and where applicable, other consultants, to perform on-site inspections of the locations involved in the project to determine where lead-based paint may be present, or are in close proximity to the work and could be impacted, as a result of the project.
- iv. Areas of deteriorated paint or other lead-containing materials may need to be identified so that loose and flaky paint, or other potential lead-containing materials, can be removed or otherwise properly handled prior to and/or during demolition and construction.
- v. Lead-based paint testing will be performed using a portable X-ray fluorescence (XRF) analyzer.

c. Hazardous Materials Consulting Services

- i. Prior to demolition or abatement, a survey of potential hazardous materials (in addition to asbestos and lead based paint (LBP) must be inventoried. CONSULTANT shall perform a visual evaluation of potential hazardous chemicals and/or ballasts to determine the need for additional mitigation efforts required for safe demolition. CONSULTANT is to visit the project site and determine what materials require sampling. CONSULTANT is to take bulk samples of all materials that are suspected to be hazardous including all unmarked containers containing unknown substances. Samples are analyzed for PCBs according to EPA Method 8082 by an accredited laboratory using proper chain-of custody procedures to collect and transport samples.
- ii. The following items require sampling:
 - Polychlorinated Biphenyl (PCB) Ballasts including capacitors
 - Mercury thermostats and light switches and fluorescent light tubes
 - Cooling units, Freon heating, refrigerators, air conditioners and drinking water fountains
 - Hydrocarbon-containing equipment (door closers)
 - Lead (lead-acid batteries)
 - Other suspect items including but not limited to paint, coatings, window film, ceramic tile, ceiling tile, resilient flooring tile, adhesives/mastics, and any other potentially hazardous or suspect materials or items.

d. Evaluation of Soil Conditions

- i. Assessing site structures for the potential presence of hazardous materials will occur concurrently with evaluating soils for the same. This requirement may be due to the Site's history and the analytes that may occur in the soils of such properties. The analytes include lead leached from LBP, organochlorine pesticides (OCP) used for termite control, PCBs from pole-mounted transformers, pesticides, fertilizers, heavy metals, hydrocarbons, and all other hazardous materials identified by DTSC as a potential threat to the health and well being of students.
- ii. To assess the potential presence of these analytes at the Site and to characterize them, if present, the CONSULTANT may be required to prepare a workplan. The proposed work for evaluation of the presence of residual lead in soil from LBP or other lead affected materials shall be conducted in a manner consistent with the California Environmental Protection Agency (Cal EPA) and Department of Toxic Substances Control (DTSC) regulations.
- iii. Soils samples may be collected within the buildings' drip lines and exterior areas with known, or the potential for, LBP. CONSULTANT shall collect samples from ground surface to approximately 0.5 feet below ground surface (bgs). Based on analytical results, additional soil samples may be collected from other lateral "step-out" positions to define the extent of soils with

Not Project Related

Project #13-135

lead exceeding current allowable regulatory limits. The exact number of samples collected at each building will be determined by accessibility.

- iv. After sample collection, the CONSULTANT will close each borehole and decontaminate drilling and sampling equipment. To close the borehole, the CONSULTANT shall backfill it with unused sample material and/or hydrated bentonite chips to grade and finish the borehole with material that is compatible with the surrounding surface.

2. Construction Phase:

- a. During the course of construction, monitor abatement work to ensure compliance with the contract requirements and completion of the work by the abatement contractor. During construction, perform the following tasks:
 - i. Attend all necessary construction meetings during the course of abatement work
 - ii. Review abatement contractor submittals
 - iii. Provide on-site inspections with daily reports and photos of abatement work. Maintain on-site records and perform monitoring during all abatement work. Perimeter monitoring for fugitive lead and asbestos at or near the entrances and or openings to the containment zone are an essential part of assuring that the containment is operating properly. This perimeter monitoring shall be performed by the CONSULTANT.
 - iv. Monitor abatement contractor's compliance with the plans, specifications and any regulations including but not limited to certification of abatement workers, ensuring proper containments, and confirmation of the removal of all asbestos, lead and hazardous materials.
 - v. Assist the District with problem resolutions associated with abatement work and keep District informed of abatement contractor's performance.
 - vi. Surveys of existing buildings and sample collection, and utilization and compliance with OSHA, AHERA and ASHARA and EPA approved methods.
 - vii. Complete written reports on all activities performed.
 - viii. Consultation on remedial action and contractor selection.
 - ix. Develop, implement and monitor a network of real-time ambient air monitoring stations to screen for potential particulate matter released from construction activities on the Project Site.
 - x. Collect and analyze a subset of daily air monitoring samples for contaminants of potential concern via Transmission electron Microscopy (TEM), Scanning Electron Microscopy (SEM), or other appropriate methodology.
 - xi. An on-site technical staff position may be required to interpret, consult and advise on air monitoring results.
 - xii. Upon completion of the contracted abatement, the CONSULTANT shall inspect the entire surface from which asbestos-containing materials have been abated as well as the entire containment setup, plastic, and/or polyethylene used in the containment setup, the decontamination setup and any other item, equipment or material within the isolated/regulated area.

Not Project Related

Project #13-135

xiii. The CONSULTANT shall verify that all surfaces are free of visible debris before approving the area.

3. Close-out Phase:

- a. Verify the Uniform Hazardous Waste Manifest, when required, has been submitted and reviewed by Office of Environmental Health and Safety (OEHS) for completeness a minimum of 48-hours prior to the date the waste is to be removed from the site. Consultant shall provide waste specific information for inclusion on the manifest. No hazardous waste may be transported away from a District site without a manifest. Submit all original paper work required to be maintained by the contract documents, this agreement, and by law to the District.
- b. Upon completion of the abatement work, prepare a Closeout Abatement Report that documents all the activities performed, including copies of all sampling forms with results, daily reports, progress photos, correspondence and any regulatory compliance forms.

4. Reports

As part of the Services, Consultant will prepare and deliver the following tangible work products to District:

- a. Assessment Reports, Abatement Plan, & Final Close-Out Report
 - i. Prepare an Assessment Report for each project and in the case of projects involving site acquisition, subsections by each property parcel including a description of the site conditions, details of the site inspection/investigations, site drawings indicated sampling locations, site photographs and laboratory results with a summary of all identified asbestos, lead or hazardous materials and soil conditions.
 - ii. Prepare recommendations and an abatement plan with an estimate of costs for abatement of the materials that will impact the project/parcels. The abatement plan shall include an Abatement Scope of Work and Abatement Technical Specifications to be included in the Project Bid Documents. The specifications will stipulate industry standard methods for abatement activities; ACBM, LBP, and HMA abatement methods; removal and disposal methods, regulations, and standards to be followed. Drawings will be included to depict the location and design of containment systems, access to abatement areas, routes for waste removal, locations of waste containers, and other details important to abatement activities. Under otherwise desired by DISTRICT, the specifications will allow for one 8-hour work shift per day of abatement. The Bid Documents will require that bids include a schedule consistent with the DISTRICT'S needs; a work plan based on specifications; a list of recently completed projects; records of any EPA or OSHA citations; and documentation of insurance, licensing, training, medical surveillance and respirator fit-testing.
 - iii. Preparation of a final report describing and quantifying identified friable and non-friable ACMs associated with the property.
 - iv. Upon completion of the abatement work, prepare a Closeout Abatement Report that documents all the activities performed, including copies of all sampling forms with results, daily reports, progress photos, correspondence and any regulatory compliance forms.

5. Time

Phase 1 initial survey & sampling report shall be provided to the District within 30 days of receipt of Notice to Proceed (NTP). Phase 2 work detailing all required remediation, abatement, and containment activities to be performed shall be provided within 45 days of receipt of NTP. Phase 3 monitoring &

Not Project Related

Project #13-135

observation reports shall be provided on a weekly basis while work is underway to summarize activities completed that week, and look ahead for upcoming activities over next two weeks. Final Close-out Abatement Report shall be provided within 30 days of completion of all remediation, abatement, and containment activities.

6. Accuracy Standards

Precision of all required reports and recommendations shall be in accordance with the professional standard of care to be expected of professional hazardous materials consultants licensed to practice in the State of California.

Not Project Related

Project #13-135

EXHIBIT "G"
TO AGREEMENT FOR CONSULTANT SERVICES #13-135

INVOICE APPROVAL LETTER & BILLING COVER SHEET

DATE:

Project No. ___: [INSERT PROJECT NAME]

Consultant: Cardno ATC ("ATC")

ATC has submitted Invoice No. _____ for review by the District's Program Manager, Caldwell Flores Winters, Inc. ("CFW"), and Assistant Superintendent of Business Services, Lisa Cline.

By signing below, a representative of ATC, hereby certifies that the invoice submitted is a true and accurate reflection of the work performed to date, is an accurate representation of the percent work completed for the phase identified in the invoice, and that the invoice submitted does not include any charges for services that have been previously paid, or rejected by the District and/or CFW.

Cardno ATC

Date

The invoice has been reviewed by the following and is recommended for payment:

Caldwell Flores Winters, Inc.

Date

Oxnard School District

Date

Lisa Cline, Assistant Superintendent,
Business and Fiscal Services

- Not Project Related
 Project #13-135

Consultant/Vendor Billing Instructions

Invoice Cover Sheet Set-Up.

- 1 See "billing tab" below for spreadsheet, these are the instructions
- 2 Enter Project Site name, DSA project number, Project Type, Invoice #, Date, Your Company Name, fax, phone, etc....
- 3 Enter PO # (Purchase Order #) provided to you when contract issued.
- 4 Feel free to include your company logo if you wish
- 5 Enter approved contract agreements, amendments, re-imbursables, allowances, etc. for which you are billing. Include summary scope of work. Enter "Cost Code" provided to you by Program Manager.
- 6 If you wish to break the contract work items down into portions that you would typically separate for progressive payments, please do that now. If your contract allows re-imbursables in addition to contract fee, please separate these values. If you require more line items to complete this step, please highlight the entire last row by clicking on the grey row # at left, press CTRL+C to copy row, right click grey row # immediately below, select "Insert Copied Cells". This can be repeated as many times as necessary. Multiple rows can be copied/inserted in a single step by highlighting multiple rows prior to copying.

First Billing.

- 5 **IMPORTANT!** When you are entering costs for your first billing, enter values (dollar amounts) **ONLY** into the green column. The percentages will change automatically. **NOTE: Select the (% Complete) billing tab if you prefer to track your billings based on total project % complete. Once % complete is entered, billable amount will populate automatically. Select the (lump sum) billing tab if you prefer to track your billings as a lump sum billable amount to date. Once lump sum amount is entered, % complete will populate automatically.**
- 6 Send invoice based on the Dollar value at the PRE-RETENTION value, if applicable.

Subsequent Billings

- 7 Manually input the dollar values from the "cost completed to date" column into the blue "total previous billings" column
- 8 Enter the corresponding dollar values/% complete values into the green column for total work complete to date.
- 9 Submit a conditional release waiver with the billing. Submit signed pay request certification form.
- 10 Email (tmiddlestadt@cfwinc.com), or mail to the CFW Oxnard office at 1901 Victoria Ave, Suite 106 Oxnard, CA 93035. Please allow 4-6 weeks for invoice processing prior to payment.
- 11 Please note that invoice amounts which exceed remaining contract balance will not be processed, and will be returned to Vendor pending additional contract agreement(s). Incorrect contract amounts, cost codes, or other errors & miscalculations can delay/prevent processing of payment.

NOTE: All Consultant/Vendor invoices must be accompanied by this worksheet to ensure proper payment. Invoices without this worksheet may be rejected and may delay payment until the next billing cycle or until the spreadsheet becomes accurate. Invoices not received by the 25th may be delayed until the next billing cycle. Contact the Program Manager with any questions regarding billing values, or any other information required, prior to submitting a billing.



ADDITIONAL REMARKS SCHEDULE

| | | | |
|---|-----------|---|--|
| AGENCY Aon Risk Services Southwest, Inc. | | NAMED INSURED ATC Group Services, Inc. | |
| POLICY NUMBER See Certificate Number: 570051838093 | | | |
| CARRIER See Certificate Number: 570051838093 | NAIC CODE | EFFECTIVE DATE: | |

ADDITIONAL REMARKS

**THIS ADDITIONAL REMARKS FORM IS A SCHEDULE TO ACORD FORM,
FORM NUMBER: ACORD 25 FORM TITLE: Certificate of Liability Insurance**

| INSURER(S) AFFORDING COVERAGE | NAIC # |
|-------------------------------|--------|
| INSURER | |
| INSURER | |
| INSURER | |
| INSURER | |

ADDITIONAL POLICIES If a policy below does not include limit information, refer to the corresponding policy on the ACORD certificate form for policy limits.

| INSR LTR | TYPE OF INSURANCE | ADDL INSR | SUBR WVD | POLICY NUMBER | POLICY EFFECTIVE DATE (MM/DD/YYYY) | POLICY EXPIRATION DATE (MM/DD/YYYY) | LIMITS | |
|----------|----------------------|-----------|----------|--|------------------------------------|-------------------------------------|--------------|-------------|
| | WORKERS COMPENSATION | | | | | | | |
| C | | N/A | | WC039901296 WC - (NJ,PA) SIR applies per policy terms & conditions | 09/30/2013 | 09/30/2014 | | |
| C | | N/A | | WC039901295 WC - (IL,KY,NC,NH,UT,VT) SIR applies per policy terms & conditions | 09/30/2013 | 09/30/2014 | | |
| C | | N/A | | WC039901294 WC - (AK,AZ,GA,VA) SIR applies per policy terms & conditions | 09/30/2013 | 09/30/2014 | | |
| C | | N/A | | WC025842892 WC - FL SIR applies per policy terms & conditions | 09/30/2013 | 09/30/2014 | | |
| C | | N/A | | WC012055045 WC - (MA,ND,OH,WA,WI,WY) SIR applies per policy terms & conditions | 09/30/2013 | 09/30/2014 | | |
| A | | N/A | | WC025842891 WC - CA SIR applies per policy terms & conditions | 09/30/2013 | 09/30/2014 | | |
| | OTHER | | | | | | | |
| D | Contractor Poll | | | PROP11781522 Pollution Coverage | 09/30/2013 | 09/30/2014 | Aggregate | \$2,000,000 |
| | | | | | | | Per Incident | \$1,000,000 |
| | | | | | | | Deductible | \$25,000 |
| | | | | | | | SIR/Deduct | \$25,000 |

OSD BOARD AGENDA ITEM

Name of Contributor: Robin I. Freeman

Date of Meeting: 3/1/17

- A. Preliminary _____
Study Session _____
Report _____
- B. Hearing: _____
- C. Consent Agenda X

Agreement Category:

- Academic
- Enrichment
- Special Education
- Support Services
- Personnel
- Legal
- Facilities

- D. Action Items _____
- E. Approval of Minutes _____
- F. Board Policies 1st Reading _____ 2nd Reading _____

Approve: Out of State Conference – Washington, DC (Freeman)

The Board’s approval is requested for the Assistant Superintendent, Robin I Freeman, to attend the Leaders to Learn From Conference on March 30-31, 2017. This conference allows collaboration and interaction with school district leaders who share the same area of interest and expertise for a deep conversation on some of the most important topics in K-12 leadership. These sessions will feature a former Leader To Learn From honoree who is an expert on the featured topic, and be moderated by an *Education Week* journalist who will lead an energetic and highly interactive discussion with the whole group. Besides taking home some new ideas and strategies, attendees will forge new connections with other district leaders that can assist and mentor throughout the conference and for years to come.

FISCAL IMPACT:

Not to exceed \$3,000 for registration, airfare, lodging and meals.

RECOMMENDATION:

It is the recommendation of the Assistant Superintendent Educational Services that the Board of Trustees approve the out of state conference attendance as outlined above.

ADDITIONAL MATERIAL: Conference Schedule.

- [Meet the 2014 Leaders \(https://leaders.edweek.org/meet-2014-leaders-videos/?intc=ltlfnvtop\)](https://leaders.edweek.org/meet-2014-leaders-videos/?intc=ltlfnvtop)
- [Meet the 2013 Leaders \(https://leaders.edweek.org/meet-the-leaders-2013/?intc=ltlfnvtop\)](https://leaders.edweek.org/meet-the-leaders-2013/?intc=ltlfnvtop)
- [Sponsor \(https://leaders.edweek.org/sponsors-information/?intc=ltlfnvtop\)](https://leaders.edweek.org/sponsors-information/?intc=ltlfnvtop)
- [Register To Attend \(https://leaders.edweek.org/select-your-registration-type/?intc=ltlfnvtop\)](https://leaders.edweek.org/select-your-registration-type/?intc=ltlfnvtop)

<https://www.facebook.com/edweek>
<https://twitter.com/educationweek>
<https://plus.google.com/+EducationWeek/posts>
<https://www.linkedin.com/company/editorial-projects-in-education>

Leaders 2017 Live Event Agenda

Hosted March 30-31, 2017 | The Mayflower Hotel
 1127 Connecticut Ave, NW
 Washington, D.C. 20036

Agenda for 2017:

Thursday, March 30, 2017

3:00 p.m.—5:00 p.m.

Hotel check-in. Leaders To Learn From registration opens!

5:00 p.m.—6:30 p.m.

Meetups

Join other school district leaders who share your area of interest and expertise for a deep conversation on some of the most important topics in K-12 leadership. These sessions will feature a former Leader To Learn From honoree who is an expert on the featured topic, and be moderated by an *Education Week* journalist who will lead an energetic and highly interactive discussion with the whole group. Besides taking home some new ideas and strategies, you will forge new connections with other district leaders that you can tap throughout the next two days and for years to come.

Growing Teacher Leaders: Harnessing the Powerful and Pivotal Potential of Evaluation

Renee Pryor, Supervisor of Evaluation Programs and Professional Development
 Lincoln County School District, Tenn.
Education Week Leaders To Learn From 2016



No one program, strategy, or pedagogy can create change that leads to academic success for schools and districts. School systems spend thousands of dollars on technology, online programs, and instructional training and professional development. And yet, they continue to be disappointed by the results.

Led by Renee Pryor, supportive and meaningful teacher evaluation, along with strategies for teacher leadership and professional development, have brought about

improved teaching and learning in Lincoln County. Pryor understands that teachers learn best from teachers and uses her influence as a district supervisor to strengthen the role of teachers as professional-development leaders in her district and across the state of Tennessee.

In a conversation with Renee Pryor and other district leaders, you will learn practical tips and strategies about:

*3Rs of Modern K-12 Education—
Redefine, Redesign and Re-imagine*
Superintendent Gail Pletnick, Dysart Unified School District, Surprise, Ariz.
Education Week Leaders to Learn From 2014



In one of Arizona's fastest-growing school

districts, Superintendent Gail Pletnick has led a personalized learning transformation that, in spite of limited resources, has engaged students and educators in new ways and improved overall achievement. Come to this session to engage with Superintendent Pletnick and other district leaders on how schools can make changes to meet the needs of a generation of learners who must succeed in the innovation age.

Attendees should come prepared to discuss the challenges and opportunities schools face as embrace and adopt personalized education. Our conversation will include:

- Efficient and effective use of technology
- Student engagement and voice in the



Educators recognized as Leaders to Learn From by *Education Week* visit the U.S. Education Department for a series of roundtable discussions on March 17, 2015, in Washington, D.C.
(Photo by T.J. Kirkpatrick)

6:30 p.m.—8:30 p.m.

Welcome Reception—Open to all attendees

Enjoy cocktails, light fare, and interactive activities with other K-12 leaders and our Leaders To Learn From alumni.



Friday, March 31, 2017

8:00 a.m.—8:50 a.m.

Networking Breakfast in the Hall of Leaders

8:50 a.m.—10:20 a.m.

2017 Leader Recognition

10:20 a.m.—10:40 a.m.

Transition Time/Coffee Break

10:40 a.m.—11:05 a.m.

Follow the Leaders

2017 Leaders will be assigned to breakout rooms and will lead a session on the topic they are being recognized for.

11:05 a.m.—11:30 a.m.

Transition Time/Coffee Break

11:30 a.m.—11:55 a.m.

Follow the Leaders

2017 Leaders will be assigned to breakout rooms and will lead a session on the topic they are being recognized for.



2016 Leaders Steve Webb and Tom Hagley addressing the crowd.

12:00 p.m.—1:00 p.m.

Networking Lunch and EdTalks!

Join your fellow leaders for a plated lunch and several exciting EdTalks from Leaders To Learn From past and present. EdTalks will provide you a taste for the day's "EdTalks Sessions" that will close our two-day gathering.

EdTalks

This year's EdTalks include:



Equity/Discipline ([https://leaders.edweek.org/profile/christopher-chatmon-executive-director-](https://leaders.edweek.org/profile/christopher-chatmon-executive-director-supporting-boys-of-color/)

supporting-boys-of-color/
with Christopher Chatmon,
Executive Director, African-American Male Achievement
Oakland Unified School District, Oakland, Calif.



"Vision 2020: My Tomorrow": School Turnaround (<https://leaders.edweek.org/profile/mary-ronan/>)

with Superintendent Mary Ronan
Cincinnati Public Schools, Cincinnati, Ohio



Community Schools Cultivate Hope, Opportunity, and Agency

(<https://leaders.edweek.org/profile/steve-webb-and-tom-hagley-superintendent-chief-of-staff-community-schools/>)
with Superintendent Steve Webb and Chief of Staff Tom Hagley
Vancouver Public Schools, Vancouver, Wash.

1:00 p.m.—2:00 p.m.

GRIT: New Frontiers in the Research on Developing Passion & Perseverance

With **Angela Duckworth**, professor of psychology, University of Pennsylvania; founder and scientific director of the Character Lab; and author, "Grit: The Power of Passion and Perseverance"

Who succeeds in school and in life? In this presentation, Angela Duckworth reviews her research on grit, the tendency to pursue long-term goals with perseverance and passion. She describes the predictive power of grit for performance in the National Spelling Bee, graduation from West Point, graduation from the Chicago Public Schools, and a variety of other contexts. She explains what makes gritty individuals different from others, and finally, she summarizes her thinking on how to cultivate grit.

What Is Grit? Should Schools Be Judged for How 'Gritty' Students Are? Angela Duckworth

2:00 p.m.—2:25 p.m.

Break

2:25 p.m.—3:30 p.m.

Keynote Presentation

Mike Schmoker, author, *Leading With Focus*, *FOCUS: Elevating the Essentials to Radically Improve Student Learning and Results Now*, finalist for “book of the year” by the Association of Education Publishers.

TEACHING and LEADING with FOCUS

In this session, teachers and leaders will learn precisely where schools should focus their precious time and resources to ensure that all students are prepared for the demands of college, careers, and citizenship. They will learn about the three most essential elements of good schooling, and how to implement them on a clear, straightforward model. The three elements are:

- Coherent curriculum
- Authentic literacy
- Soundly-structured lessons

Despite their unrivaled power for improving performance in any school, these elements continue to be misunderstood—and grossly under-implemented. For this reason, they should be our first and highest priority.



Schmoker is a former administrator, English teacher, and football coach. He has written six books and dozens of articles for educational journals, newspapers, and for TIME magazine.

His most recent book is *Leading With Focus* which follows his earlier best-seller *FOCUS: Elevating the Essentials to Radically Improve Student Learning*. His previous bestseller is *Results Now*, which was selected as a finalist for "book of the year" by the Association of Education Publishers.

Schmoker is the 2014 recipient of the Distinguished Service Award by the National Association of Secondary School Principals for his publications and presentations. He has consulted and keynoted throughout the US, Canada, Australia, China, and Jordan.

3:30 p.m.—4:00 pm.

Transition Time/Coffee Break

4:00 p.m.—5:00 p.m.

EdTalk Sessions

Your chance to get up close and personal with this year's EdTalk Leaders that you met at lunch. Examine more deeply the issues that matter to your districts:



Equity/Discipline ([https://leaders.edweek.org/profile/christopher-chatmon-executive-director-](https://leaders.edweek.org/profile/christopher-chatmon-executive-director-supporting-boys-of-color/)

[supporting-boys-of-color/](https://leaders.edweek.org/profile/christopher-chatmon-executive-director-supporting-boys-of-color/)) with Christopher Chatmon
Executive Director, African-American Male Achievement
Oakland Unified School District, Oakland, Calif.

Vision 2020: My Tomorrow
Superintendent Mary Ronan, Cincinnati Public Schools
Education Week Leaders to Learn From 2013

5:00 p.m.—6:30 p.m.

Closing Reception



Vision 2020: My Tomorrow is a new,

comprehensive school improvement plan that Superintendent Mary Ronan is spearheading to expand equity, access, and opportunity for all students to attend great schools. The plan builds upon Cincinnati public school's groundbreaking "My Tomorrow" initiative to prepare students with the real-world knowledge and skills

Join your fellow leaders to unwind and recap all you've learned, shared, and discovered as we close out Leaders To Learn From 2017 together.

Diamond Sponsors: **RENAISSANCE**

(<http://www.renaissance.com/>) **SCHOLASTIC**
open a world of possible

Community Schools Cultivate Hope, Opportunity and Agency

Superintendent Steve Webb and Chief of Staff Tom Hagley, Vancouver, Wash., Public Schools
Education Week Leaders to Learn From 2016



Community schools are a strategy to unite

and mobilize families, schools, and communities in educating the next generation. By leveraging an array of expertise and services, community schools can reduce barriers to learning, improve student outcomes, and build strong school and neighborhood assets. Led by Superintendent Steve Webb and Chief of Staff Tom Hagley, the Family-Community Resource Centers in 18 school sites in the Vancouver Public Schools in Washington state provide basic-needs support, parent and family engagement activities, early-childhood education and out-of-school-time programs. A mobile Family-Community Resource Center serves other sites year-round. The whole-child focus of the Family-Community Resource Centers has helped lift Vancouver's on-time graduation rate and close achievement gaps. Through presentations and site visits, Webb and Hagley have assisted other public school systems in the local area and throughout the Pacific Northwest in designing a

(<http://www.scholastic.com/professional>)



(<https://www.achieve3000.com/>)

ACHIEVE3000

Livestream Sponsor:



Education

(<http://www.rosettastone.com/>)

Produced with support from The Wallace Foundation, at www.wallacefoundation.org (<http://www.wallacefoundation.org>)

Leaders To Learn From is a project of **Education Week** (<http://www.edweek.org>), the nation's foremost source for K-12 news and analysis.

OSD BOARD AGENDA ITEM

Name of Contributor: Jesus Vaca/Jonathan Koch

Date of Meeting: March 1, 2017

- A. Preliminary _____
Study Session _____
Report _____
- B. Hearing: _____
- C. Consent Agenda X
Agreement Category:
 - _____ Academic
 - _____ Enrichment
 - _____ Special Education
 - _____ Support Services
 - _____ Personnel
 - _____ Legal
 - _____ Facilities
- D. Action Items _____
- E. Approval of Minutes _____
- F. Board Policies 1st Reading _____ 2nd Reading _____

Personnel Actions (Vaca/Koch)

The attached are recommended personnel actions presented to the Board of Trustees for consideration. The salary placement for the individuals employed will be in accordance with salary regulations of the district. Personnel actions include: New Hires, transfers, pay changes, layoffs, recall from layoffs, resignations, retirements, and leave of absence.

FISCAL IMPACT:

RECOMMENDATION:

It is the recommendation to approve the Personnel Actions, as presented.

ADDITIONAL MATERIAL:

Attached: Classified Personnel Actions (page)
Certificated Personnel Actions

CERTIFICATED PERSONNEL

Listed below are recommended certificated personnel actions presented for consideration by the Board of Trustees. The salaries for the individuals employed will be determined in accordance with salary regulations of the District.

NEW HIRES

| | | |
|-----------------|------------------------------|-----------------------|
| Mark Freeman | Psychologist, Pupil Services | 2016/2017 School Year |
| Kandiss Crone | Substitute Teacher | 2016/2017 School Year |
| Lindsay Gann | Substitute Teacher | 2016/2017 School Year |
| Christine Yamek | Substitute Teacher | 2016/2017 School Year |
| | Substitute Teacher | 2016/2017 School Year |

Resignations

| | | |
|-------------------|----------------------|------------|
| April Daniely | PE, Lemonwood School | 2/28/2017 |
| Joy D. Livingston | RSP, Haydock School | 02/28/2017 |

Retirement

| | | |
|-------------|--------------------|------------|
| Jenks, Anne | Principal, McKinna | 06/30/2017 |
|-------------|--------------------|------------|

CLASSIFIED PERSONNEL ACTIONS

March 1, 2017

New Hire

| | | |
|------------------|--|------------|
| Contreras, Janet | Paraeducator II, Position #679 Special Education 5.75 hrs./183 days | 02/13/2017 |
|------------------|--|------------|

Limited Term

| | | |
|---------------------------|------------------------|------------|
| Barajas, Monica | Child Nutrition Worker | 02/08/2017 |
| Calderon Rodrigues, Lidia | Clerical | 02/09/2017 |
| Davenport, Taylor | Paraeducator | 02/07/2017 |
| Fierro, Raquel | Paraeducator | 02/07/2017 |
| Flores, Saray | Paraeducator | 02/06/2017 |
| Gil, Alicia | Child Nutrition Worker | 02/06/2017 |
| Herron-Luna, Julieanna | Clerical | 02/06/2017 |
| Magana, Karyssa | Paraeducator | 02/06/2017 |
| Ramirez, Rosalinda | Paraeducator | 02/13/2017 |
| Reza-Castruita, Erica | Clerical | 02/09/2017 |
| Robles, Cecilia | Paraeducator | 02/06/2017 |

Exempt

| | | |
|-----------------------|------------------|------------|
| Arevalo Barajas, Desi | Campus Assistant | 01/18/2017 |
| Chavez, Gerardo | Campus Assistant | 02/02/2017 |

Reinstatement

| | | |
|-----------------------|--|------------|
| Bustamante, RosaMaria | Paraeducator III, Position #2000 Special Education 5.75 hrs./183 days | 02/02/2017 |
| Galvan, Judith | Paraeducator III, Position #7999 Special Education 5.75 hrs./183 days | 02/14/2017 |

Released during Probation

| | | |
|------|--|------------|
| 9543 | Maintenance Worker I, Position #5844 Facilities 8.0 hrs./246 days | 02/03/2017 |
| 9731 | Grounds Maintenance Worker I, Position #1173 Facilities 8.0 hrs./246 days | 02/14/2017 |
| 4349 | Lead Custodian, Position #2397 Soria 8.0 hrs./246 days | 02/15/2017 |

BOARD AGENDA ITEM

Name of Contributor: Dr. Morales/Lisa Cline

Date of Meeting: 3/01/17

STUDY SESSION _____

CLOSED SESSION _____

SECTION A-1: PRELIMINARY _____

SECTION A-II: REPORTS _____

SECTION B: HEARINGS _____

SECTION C: CONSENT AGENDA _____

Agreement Category:

____ Academic

____ Enrichment

____ Special Education

____ Support Services

____ Personnel

____ Legal

X Facilities

SECTION D: ACTION _____

SECTION F: BOARD POLICIES 1st Reading _____ 2nd Reading _____

Consider Approval of Change Order No. 003 to the Construction Services Agreement #15-198 with Swinerton Builders related to additional work required by the District for the Lemonwood K-8 School Reconstruction (Cline/CFW)

The Oxnard School District ("District") Board of Trustees ("Board") Facilities Implementation Plan first adopted in January 2013, calls for the reconstruction of the Lemonwood K-8 School ("Project"). The Project includes the construction of a new school facility at the existing Lemonwood school site. The new facilities will provide for a complete K-8 educational program and will consist of a new combined administration and library building, a new multi-purpose room/gymnasium, a 2-story classroom building, kindergarten classroom building and playfields, hardscape and green space to service the new school.

The original Facilities Implementation Plan called for the construction of the new school beginning in phase 2 of the program in 2017-2018 academic year. CFW, working in consultation with District staff, has accelerated the commencement of construction as a result of thoughtful planning and early access to General Obligation Bond dollars that were not projected to be available until the future.

During grading operations for Classroom Building 1, unidentified, unforeseen underground obstructions were encountered that required their removal and disposal. On June 8, 2016, a section of sixteen-inch (16") diameter concrete pipe was discovered. The pipe was inactive and the discovery did not interfere with the Lemonwood School's daily operation. Efforts were implemented, and an approximate eighty feet (80') of this pipe was removed. During grading operations on July 7, 2016, at a location approximately forty feet (40') south from the location of the sixteen-inch (16") diameter concrete pipe, two (2) sections of two-inch (2") diameter abandoned steel petroleum pipelines were encountered. These pipe lines were also inactive and the discovery did not interfere with the Lemonwood School's daily operation. The Project Environmental Consultant ATC Group Services was contacted to perform observation and testing to assure compliance with the Department of Toxic Substance Control ("DTSC") as required when discovery of previously unknown potential contaminants have been encountered. Full compliance with DTSC requirements has been accomplished.

This recommended agenda item provides for the Board's consideration and approval of Change Order No. 003. Five items are being addressed in this Change Order: (1) It was determined that the planned provisions for the new power to connect to the existing equipment were not compatible. A transformer is being installed to provide adequate power for the existing ECDC/Preschool building while it continues operations. (2) The portable classroom buildings are being used as science classrooms and require temporary water and sewer lines. During preconstruction, these portables were not considered as science classrooms and were not required to have water and sewer lines. (3) Submittal review of hardware manufacturers revealed that there was a preference for Schlage over Sargent to maintain district standards. (4) Submittal review of light fixtures established the preference of LED lighting over the specified. (5) District requested wood casework throughout the project in lieu of what was specified.

FISCAL IMPACT

One Hundred Forty Thousand Eight Hundred Seventy-One Dollars and Fifty-Seven Cents (\$140,871.57) to be paid out of Master Construct and Implementation Program funds.

RECOMMENDATION

It is the recommendation of the Superintendent, and the Deputy Superintendent, Business and Fiscal Services, in conjunction with Caldwell Flores Winters, Inc., that the Board of Trustees approve Change Order No. 003 to the Construction Services Agreement #15-198 with Swinerton Builders to provide Construction Services related to the Lemonwood Elementary School Reconstruction Project of Measure "R" Program under the Lease-Leaseback delivery method pursuant to Section 17406 of the California Education Code.

ADDITIONAL MATERIAL

Attached: Change Order No. 003, Swinerton Builders (2 Pages)
 Swinerton Builders PCI # 0052-1 (9 Pages)
 Swinerton Builders PCI # 0059 (14 Pages)
 Swinerton Builders PCI # 0072 (9 Pages)
 Swinerton Builders PCI # 0075 (32 Pages)
 Swinerton Builders PCI # 0079-1 (6 Pages)
 Construction Services Agreement #15-198, Swinerton Builders (19 Pages)



CHANGE ORDER

Date: 03.01.2016

CHANGE ORDER NO. 003

PROJECT: LEMONWOOD K-8 RECONSTRUCTION
O.S.D. BID No. N/A
O.S.D. Agreement No. 15-198

OWNER: Oxnard School District
 1051 South A Street
 Oxnard, CA. 93030

ARCHITECT SVA Architects, Inc.
 3 MacArthur Place, Suite 850
 Santa Ana, CA 92707

CONTRACTOR:
SWINERTON BUILDERS
 865 South Figueroa St., Suite 3000
 Los Angeles, CA 90017
Attn: Mr. Michael Darquea

Architects Proj. No.: 2013-40121
D.S.A. File No.: 56-22
D.S.A. App. No.: 03-116026

CONFORMANCE WITH CONTRACT DOCUMENTS, PROJECT MANUAL, DRAWINGS AND SPECIFICATION. All Change Order work shall be in strict conformance with the Contract Documents, Project Manual, Drawings, and Specifications as they pertain to work of a similar nature.

| | |
|--|-------------------------|
| ORIGINAL CONTRACT SUM..... | \$ 29,575,897.91 |
| NET CHANGE - ALL PREVIOUS CHANGE ORDERS (001-002)..... | \$ 13,234.17 |
| ADJUSTED CONTRACT SUM..... | \$ 29,589,132.08 |
| NET CHANGE - | \$ 140,871.57 |
| Total Change Orders to Date: 003..... | \$ 154,105.74 |
| ADJUSTED CONTRACT SUM THROUGH CHANGE ORDER NO.: 003.. | \$ 29,730,003.65 |
| Anticipated Commencement Date..... | May 4, 2016 |
| Actual Commencement Date: | May 23, 2016 |
| Original Completion Date: | July 04, 2018 |
| Original Contract Time: | 791 Calendar Days |
| Time Extension for all Previous Change Orders: | Zero Days |
| Time Extension for this Change Order: | Zero Days |
| Adjusted Completion Date: | August 27, 2018 |
| Percentage | (0.52%) |

| Item | Description | Unforeseen Condition (UFO) | Additional Scope (AS) | Design Clarification (DC) | Code Requirement |
|------|--|----------------------------|-----------------------|---------------------------|------------------|
| 1. | PCI 52-1 Plan provisions to connect new power to existing non-compatible equipment | \$36,410.21 | | | |
| 2. | PCI 59 Temporary water and sewer lines to existing portable classrooms | | \$15,540.43 | | |
| 3. | PCI 72 Change of specified manufacturer from Sargent to Schlage | | | \$50,072.23 | |
| 4. | PCI 75 Lighting package changes per EEOR | | | \$22,365.34 | |
| 5. | PCI 79-1 Add wood casework throughout the project per submittal markups | | \$16,483.36 | | |
| | Totals | \$36,410.21 | \$32,023.79 | \$72,437.57 | |

Total Change Order No. \$ 140,871.57

**NOT VALID UNTIL SIGNED BY THE ARCHITECT, CONTRACTOR AND ASST. SUPT. BUSINESS SERVICES OR PURCHASING DIRECTOR*

APPROVAL (REQUIRED):

ARCHITECT: _____

DATE: _____

CONTRACTOR: _____

DATE: _____

RECOMMENDED FOR APPROVAL:

OSD DSA INSPECTOR: _____

DATE: _____

DEPUTY SUPERINTENDENT BUSINESS AND FISCAL SERVICES: _____

DATE: _____

APPROVAL (REQUIRED):

BOARD APPROVAL

DATE: _____

DEPUTY SUPT./PURCHASING DIRECTOR: _____

DATE: _____

DSA APPROVAL

DATE: _____



November 16, 2016

Oxnard School District
 1051 South A Street
 Oxnard, CA, 93030

Attn: Ms. Marlene Hickle/CFW, INC.

Subject: Swinerton Builders Job 16055106 - Lemonwood K-8 School LLB
 PCI No. 0052-1

David #304391 from 1/3/17
1/3/17 - Provided New - To Be Reviewed next meeting
2/7/17 - District Adding scope for future ECDC approved.

Dear Ms. Hickle,

We request a Change Order to our contract for the following:

Plan provisions for new power to connect to existing equipment is non-compatible. Provide new provisions per RFI 0084

| Phase | Category | Description | Subcontractor | Quote |
|--------|----------|---|-----------------------------|------------------|
| 260010 | 71140 | Plan provisions for new power to connect to existing equipment is non-compatible. Provide new provisions per RFI 0084 | TAFT ELECTRIC COMPANY | 30,505.00 |
| | | | Subtotal | 30,505.00 |
| 007480 | 71160 | Subguard | 1.15% | 350.81 |
| 007410 | 71160 | Builders Risk | 0.6% | 185.14 |
| 007420 | 71160 | General Insurance | 1.15% | 354.84 |
| 007510 | 71160 | P&P Bond | 1% | 305.05 |
| 991000 | 79999 | Change Order Fee | <i>Question mark-up</i> 15% | 4,709.37 |
| | | | Markup Subtotal | 5,905.21 |
| | | | PCI Total | 36,410.21 |

TOTAL AMOUNT OF THIS CHANGE ORDER REQUEST: **36,410.21.**

Please NOTE:

- » The incorporation of this revision in to the contractual scope of work may have an impact on our schedule, which is yet to be finalized. Once determined, the job schedule will be adjusted accordingly to show the effect of this revision on the final project completion date..
- » The terms (cost and schedule impact) of this change order request are subject to review and a requote if not accepted within days of its issuance.
- » This request does not include additional cost or delay due to late approval.

2/7/17 - MH. TB 2/7/17



X We **HAVE** proceeded with this revised work per your instructions. Please issue a change order.

Upon acceptance of this change order request, a formal change order will be issued. Acceptance also acknowledges that Swinerton Builders has proceeded with the above change in scope.

If you have any questions or comments pertaining to this matter, please contact the undersigned.

Sincerely,
Swinerton Builders

Bill Gray
PM
Date: _____

11/16/2016

Quotation accepted by:
Oxnard School District

By: _____

Date: _____



Taft Electric Company

1694 Eastman Avenue
Ventura, CA 93003

(805)642-0121
Contractor License # 772245

Change Order Request

Detailed, Grouped by Each Number

2241 Lemonwood
2200 Carnegie Court
Oxnard, CA 93033

Project # 2241
Tel: Fax:

TAFT ELECTRIC COMPANY

Change Order Request: 012 r002

Date: 11/16/2016

To: Bill Gray
Swinerton Builders
865 S. Figueroa Street
Los Angeles, CA 90017

From: Matt Gobuty
TAFT ELECTRIC COMPANY
P.O. Box 3416
Ventura, CA 93006

| Description | Category | Status |
|-------------------------|----------|-----------|
| ECDC - Preschool Feeder | | Submitted |

| Reference | Required By | Days Req | Amt Req |
|--|-------------|----------|---------|
| TEC RFI 019R1, Swinerton RFI 84 (attached) | 11/23/2016 | 0 | 30,505 |

Notes

We are submitting the above cost to provide temporary power to ECDC/Preschool/existing building 3. This includes:

- provide and install 100A fusible disconnect in Existing Storage 308
- Terminate MSB-5 Feeder to disconnect
- provide and install 112.5KVA transformer in permanent location (existing storage 308)
- feed existing panel in Existing Classroom 1 from 112.5KVA transformer
- Cutover, then safe-off existing feeder.

EXCLUSIONS:

- Premium time for weekend/after-hours work if required (ROM: if double time, add \$13,494)
- Removal of furniture, items in storage, ceiling tiles, etc. (Owner is to provide workable pathway)
- Additional engineering
- LV systems: Fire alarm, tel/data, clock, PA, security (to be priced in separate COR if required)

R1: Remove 3% consumables and material handling
R2: Provide credit for 60' trench + conduit

This quote is valid for 30 calendar days from the above date. we reserve our right to re-quote this proposal should the approval take longer than 30 days.

Attached is the back up for your review. Please call should you have any questions.

Matt Gobuty
Project Manager
(805)654-7994

| PCO No | Date | Reference | Amt Prop | Days Req | Category | Reason |
|--------|------|--------------------|--------------|----------|----------|--------|
| | | Description | Notes | | | |

ECDC - Preschool - Existing Building 3

MSB5 (contract routing)

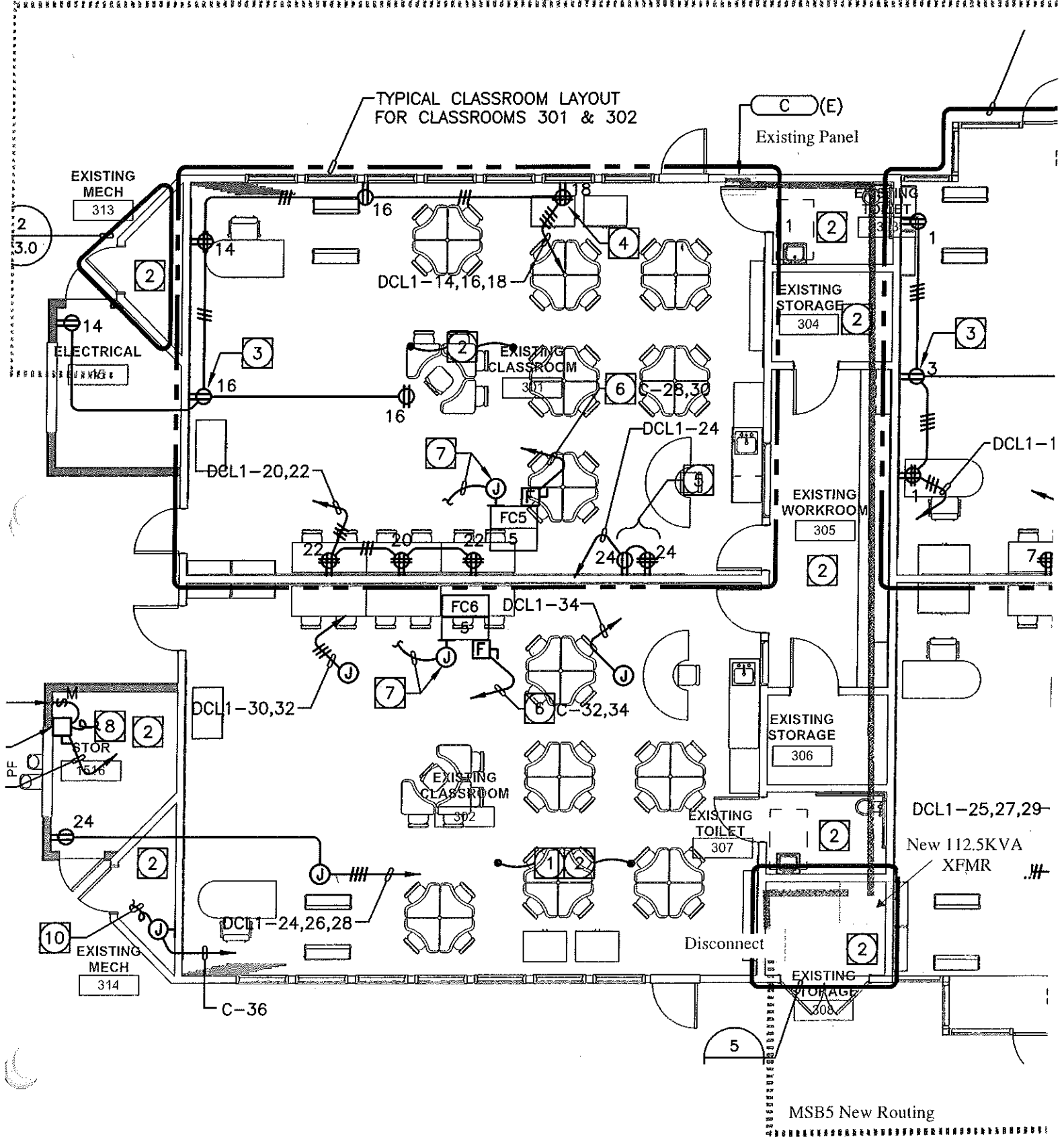

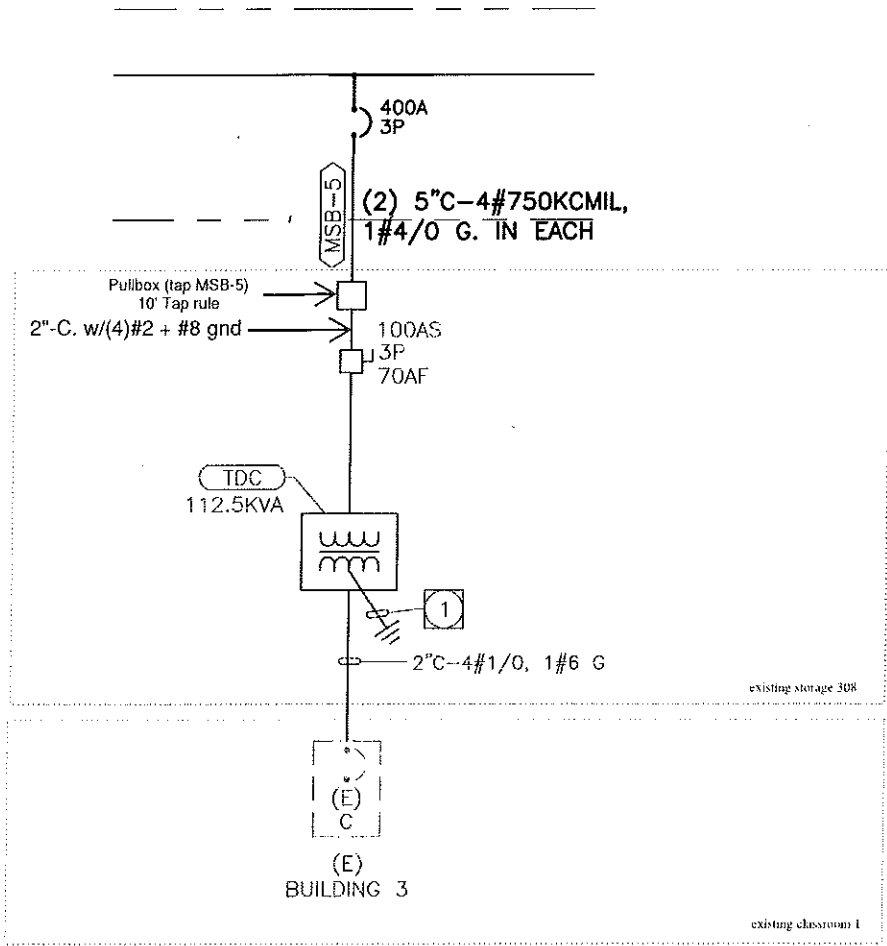

Job ID: 2241 LEMONWOOD COR
 Project: 2241 Lemonwood COR



Takeoff

Vendor: COST Labor Level: LABOR 1 6 Oct 2016 7:49:12

Region: COR 012 PRESCHOOL FEEDER

| Item # | Qty | U/M | Q/M | Size | Description | Material Unit | Material Result | Labor Unit | Labor Result |
|--------|-----|-----|-----|--------------------|-------------------------------------|---------------|-----------------|------------|--------------|
| | 0 | | | | REGULAR TIME | | | | |
| | 0 | | | | TERMINATE FEEDER CONDUITS TO RM 308 | | | | |
| 28 | 1 | M | | | 4X4X8 PRECAST CONCRETE PULLBOX | 0.0000 | 0.00 | 12.0000 | 12.00 |
| 500191 | 1 | FT | M | | CONCRETE FLOOR SAW CUT | 800.0000 | 800.00 | 0.0000 | 0.00 |
| 25 | 1 | M | | | CONCRETE PATCH | 1,100.0000 | 1,100.00 | 0.0000 | 0.00 |
| 390078 | 15 | FT | M | 18W x 36D | HAND TRENCHING SAND | 0.0000 | 0.00 | 0.9000 | 13.50 |
| | 0 | | | | 100A DISCONNECT TO TDC XFMR | | | | |
| 710035 | 1 | EA | M | 24X24X8 | P-BOX-GALV SCREW CVR | 85.5806 | 85.58 | 3.5000 | 3.50 |
| 220440 | 1 | EA | M | 100/3 | FUSIBLE SAFETY SWITCH | 0.0000 | 0.00 | 4.4000 | 4.40 |
| 230111 | 3 | EA | M | 100 AMP | RK5 TIME DELAY 600V FUSE | 35.2455 | 105.74 | 0.0600 | 0.18 |
| 500163 | 2 | EA | M | 5 | ENCLOSURE HOLE PUNCH | 0.0000 | 0.00 | 0.9500 | 1.90 |
| 10051 | 10 | FT | M | 2 | EMT | 3.7302 | 37.30 | 0.0800 | 0.80 |
| 30241 | 4 | EA | M | 2 | EMT STEEL COMP IN-THROAT CONN | 11.7799 | 47.12 | 0.4000 | 1.60 |
| 30557 | 2 | EA | M | 2 | EMT LB CONDUIT BODY | 56.1074 | 112.21 | 1.3500 | 2.70 |
| 30601 | 2 | EA | M | 2 | EMT CONDUIT BODY CVR | 16.1711 | 32.34 | 0.0396 | 0.08 |
| 60155 | 1 | EA | M | 2 x12 | GRS NIPPLE | 16.3699 | 16.37 | 0.6000 | 0.60 |
| 40120 | 4 | EA | M | 2 | LOCKNUT | 3.4569 | 13.83 | 0.4000 | 1.60 |
| 40212 | 2 | EA | M | 2 | GRD BUSHING INSULATED | 17.2493 | 34.50 | 0.6000 | 1.20 |
| 20 | 2 | M | | | CONDUIT SUPPORT | 10.0000 | 20.00 | 0.2500 | 0.50 |
| 80019 | 45 | FT | M | 2 | THHN COMPACT ALUM | 0.4889 | 22.00 | 0.0170 | 0.77 |
| 80000 | 15 | FT | M | 6 | THHN ALUM | 0.2921 | 4.38 | 0.0110 | 0.17 |
| | 0 | | | | TDC: 112.5 KVA TRANSFORMER | | | | |
| TITLE | 1 | M | | 112KVA 480/208Y120 | DRY TRANSFORMER | 0.0000 | 0.00 | 0.0000 | 0.00 |
| 190015 | 1 | EA | M | 112.5 KVA | 3PH DRY TRANSFORMER | 0.0000 | 0.00 | 18.0000 | 18.00 |
| 50005 | 3 | FT | M | 1 1/2 | FLEXIBLE STEEL CONDUIT | 2.5840 | 7.75 | 0.1500 | 0.45 |
| 50027 | 1 | EA | M | 1 1/2 | FLEX COND ANGLE CONN | 19.2299 | 19.23 | 0.3000 | 0.30 |
| 50038 | 1 | EA | M | 1 1/2 | FLEX COND STRAIGHT CONN | 7.7232 | 7.72 | 0.2500 | 0.25 |

Taft Electric Company
 1694 Eastman Avenue
 Ventura, CA 93003
 Phone: 805-642-0121
 Web: www.taftelectric.com

Region: COR_012 PRESCHOOL FEEDER

| Item # | Qty | U/M | Q/M | Size | Description | Material Unit | Material Result | Labor Unit | Labor Result |
|--------|-----|-----|-----|------------------|--|---------------|-----------------|------------|--------------|
| 40211 | 2 | EA | M | 1 1/2 | GRD BUSHING INSULATED | 12.4138 | 24.83 | 0.5000 | 1.00 |
| 500157 | 1 | EA | M | 1 1/2 | ENCLOSURE HOLE PUNCH | 0.0000 | 0.00 | 0.6500 | 0.65 |
| 70042 | 27 | FT | M | 2/0 | THHN/THWN CU (STR) | 2.5787 | 69.63 | 0.0240 | 0.65 |
| 70118 | 9 | FT | M | 6. | GREEN THHN CU (GRD 200A) | 0.5820 | 5.24 | 0.0110 | 0.10 |
| 100023 | 3 | EA | M | 2/0 | AL/CU CRIMP LUG 2-HOLE | 18.3610 | 55.08 | 0.7500 | 2.25 |
| 100003 | 1 | EA | M | 6. | AL/CU CRIMP LUG 1-HOLE | 6.5648 | 6.56 | 0.3000 | 0.30 |
| 50009 | 3 | FT | M | 3 1/2 | FLEXIBLE STEEL CONDUIT | 7.5375 | 22.61 | 0.4000 | 1.20 |
| 50064 | 1 | EA | M | 3 1/2 | FLEX COND STRAIGHT INS-THROAT CONN | 279.3417 | 279.34 | 0.6000 | 0.60 |
| 50053 | 1 | EA | M | 3 1/2 | FLEX COND ANGLE INS-THROAT CONN | 585.9694 | 585.97 | 0.7200 | 0.72 |
| 40215 | 2 | EA | M | 3 1/2 | GRD BUSHING INSULATED | 33.2905 | 66.58 | 0.9000 | 1.80 |
| 500161 | 1 | EA | M | 3 1/2 | ENCLOSURE HOLE PUNCH | 0.0000 | 0.00 | 0.8500 | 0.85 |
| 70046 | 72 | FT | M | 250 | THHN/THWN CU (STR) | 4.9121 | 353.67 | 0.0320 | 2.30 |
| 70120 | 9 | FT | M | 3. | GREEN THHN CU (GRD 400A) | 1.0679 | 9.61 | 0.0150 | 0.14 |
| 100026 | 8 | EA | M | 250 | AL/CU CRIMP LUG 2-HOLE | 19.2020 | 153.62 | 1.1000 | 8.80 |
| 100005 | 1 | EA | M | 2. | AL/CU CRIMP LUG 1-HOLE | 6.8302 | 6.83 | 0.4500 | 0.45 |
| 160109 | 4 | EA | M | 3/8 x 3" | WEDGE ANCHOR | 0.9624 | 3.85 | 0.2200 | 0.88 |
| 160881 | 4 | EA | M | 4"x4"x.04 .57psi | POLYURETHANE PAD | 7.9200 | 31.68 | 0.0650 | 0.26 |
| | 0 | | | | TDC XFMR TO EXISTING PANEL RM 301 | | | | |
| 10052 | 80 | FT | M | 2 1/2 | EMT | 6.1827 | 494.62 | 0.0950 | 7.60 |
| 21 | 1 | | M | | PENETRATION THRU EXISING STRUCTURE | 0.0000 | 0.00 | 2.0000 | 2.00 |
| 29 | 2 | | M | 2-1/2 | FRIESTOPPING | 30.0000 | 60.00 | 0.3500 | 0.70 |
| 20 | 10 | | M | | CONDUIT SUPPORT | 10.0000 | 100.00 | 0.2500 | 2.50 |
| 20174 | 2 | EA | M | 2 1/2 | EMT 90-DEG ELBOW | 22.3300 | 44.66 | 0.6000 | 1.20 |
| 20194 | 2 | EA | M | 2 1/2 | EMT FIELD BEND | 0.0000 | 0.00 | 1.2000 | 2.40 |
| 30142 | 3 | EA | M | 2 1/2 | EMT STEEL-COMP COUPLING | 41.5667 | 124.70 | 0.8000 | 2.40 |
| 30192 | 2 | EA | M | 2 1/2 | EMT DC COMP INS-THROAT CONN | 13.1563 | 26.31 | 0.5000 | 1.00 |
| 500159 | 1 | EA | M | 2 1/2 | ENCLOSURE HOLE PUNCH | 0.0000 | 0.00 | 2.0000 | 2.00 |
| 30558 | 2 | EA | M | 2 1/2 | EMT LB CONDUIT BODY | 136.4414 | 272.88 | 2.0000 | 4.00 |
| 30602 | 2 | EA | M | 2 1/2 | EMT CONDUIT BODY CVR | 38.8000 | 77.60 | 0.0396 | 0.08 |
| TITLE | 2 | | M | 2 1/2 | CHASE NIPPLE L-NUT PLASTIC-BUSH | 0.0000 | 0.00 | 0.0000 | 0.00 |
| 60007 | 2 | EA | M | 2 1/2 | BUSHED CHASE NIPPLE-STEEL | 12.2813 | 24.56 | 0.3500 | 0.70 |
| 40121 | 2 | EA | M | 2 1/2 | LOCKNUT | 3.1624 | 6.32 | 0.5000 | 1.00 |
| 40177 | 2 | EA | M | 2 1/2 | PLASTIC BUSHING | 4.3442 | 8.69 | 0.3500 | 0.70 |
| 80023 | 240 | FT | M | 3/0 | THHN COMPACT ALUM | 1.3268 | 318.43 | 0.0234 | 5.62 |
| 80019 | 80 | FT | M | 2. | THHN COMPACT ALUM | 0.5257 | 42.05 | 0.0170 | 1.36 |

Taft Electric Company

1694 Eastman Avenue
Ventura, CA 93003

Phone: 805-642-0121
Web: www.taftelectric.com

Region: COR_012 PRESCHOOL FEEDER

| Item # | Qty | U/M | Q/M | Size | Description | Material Unit | Material Result | Labor Unit | Labor Result |
|--------|-----|-----|-----|------|------------------|---------------|-----------------|------------|--------------|
| 100162 | 8 | EA | M | 3/0 | WIRE TERMINATION | 0.0000 | 0.00 | 0.4500 | 3.60 |
| 100158 | 2 | EA | M | 2. | WIRE TERMINATION | 0.0000 | 0.00 | 0.3000 | 0.60 |
| 26 | 1 | | M | | CUTOVER | 0.0000 | 0.00 | 12.0000 | 12.00 |

Phase Totals: 5,742.02 138.89

Job Totals: 5,742.02 138.89

Taft Electric Company

1694 Eastman Avenue
Ventura, CA 93003

Phone: 805-642-0121
Web: www.taftelectric.com



November 4, 2016

Oxnard School District
 1051 South A Street
 Oxnard, CA, 93030

Attn: Marlene Hickle/ Greg Grant – CFW, INC.

Subject: Swinerton Builders Job 16055106 - Lemonwood K-8 School LLB
 PCI No. 0059 Sewer and water relocation at existing portable classrooms

Dear Ms. Hickle,

We request a Change Order to our contract for the following:

During preconstruction it was the intent to disable the water supply to the portable classrooms knowing that the existing sewer would be removed due to location of lift station within the footprint of the new MPR building. After the project has started it has become known that the classrooms are now being used as a science classroom and water and sewer are required. This ROM is to provide temporary utility services to the classrooms.

| Phase | Category | Description | Subcontractor | Quote |
|--------|----------|---|------------------------|------------------|
| 330200 | 71140 | Temporary water and sewer lines to existing portable classrooms | BALI CONSTRUCTION INC. | 13,020.00 |
| | | | Subtotal | 13,020.00 |
| 007480 | 71160 | Subguard | 1.15% | 149.73 |
| 007410 | 71160 | Builders Risk | 0.6% | 79.02 |
| 007420 | 71160 | General Insurance | 1.15% | 151.45 |
| 007510 | 71160 | P&P Bond | 1% | 130.20 |
| 991000 | 79999 | Change Order Fee | 15% | 2,010.03 |
| | | | Markup Subtotal | 2,520.43 |
| | | | PCI Total | 15,540.43 |

C.I.

TOTAL AMOUNT OF THIS CHANGE ORDER REQUEST: **15,540.43.**

Please NOTE:

- » The incorporation of this revision in to the contractual scope of work may have an impact on our schedule, which is yet to be finalized. Once determined, the job schedule will be adjusted accordingly to show the effect of this revision on the final project completion date..
- » The terms (cost and schedule impact) of this change order request are subject to review and a requote if not accepted within days of its issuance.
- » This request does not include additional cost or delay due to late approval.

 X We **HAVE** proceeded with this revised work per your instructions. Please issue a change order.



Upon acceptance of this change order request, a formal change order will be issued. Acceptance also acknowledges that Swinerton Builders has proceeded with the above change in scope.

If you have any questions or comments pertaining to this matter, please contact the undersigned.

Sincerely,
Swinerton Builders

A handwritten signature in orange ink, appearing to read "Bill Gray", is written over the printed name.

Bill Gray
PM
Date: _____

11-04-2016

Quotation accepted by:
Oxnard School District

By: _____

Date: _____



9852 JOE VARGAS WAY
S. El Monte, CA 91733
Telephone (626) 442-8003
Fax (626) 442-8315

November 1, 2016

Swinerton Builders
17731 Mitchell North Suite 200
Irvine CA 92614

Attention: Scott Augustine

Email: Saugustine@swinerton.com

Reference: Lemonwood Elementary
2200 Carnegie Court
Oxnard CA 93033
GC Contract # 16055106
GC Job # 16055106
Bali Project # 16-043
GC/Owner Ref.#

Subject: C.O.R. Number 4
Describe Work: Sewer and water line work

Scott Augustine

We hereby submit our Change Order Request for the above referenced project. All work was performed and completed as directed by your company on a time and material basis.

We have attached, for your review, signed extra work tickets to substantiate all costs incurred. Any additional costs associated with this work will be submitted on a subsequent change order. Below is a cost summary.

| <u>Date</u> | <u>Ticket #</u> | <u>Amount</u> |
|--------------|-----------------|-------------------------------|
| 10/6/16 | 10770 | 4,343.00 |
| 10/7/16 | 10771 | 6,268.00 |
| 10/10/16 | 10772 | 873.00 |
| 10/25/16 | 14491 | 1,536.00 |
| TOTAL | | <u>\$13,020.00</u> <i>ct.</i> |

Bali Construction, Inc. requests a formal Contract Change Order be issued immediately. Thank you for your prompt attention to this matter.

If you have any questions, please call.

Yours truly,
Bali Construction, Inc.

Kevin Delate

Extra Work

Bali Construction, Inc

9852 E. Joe Vargas Way
 So. El Monte, Ca 91733
 Telephone (626) 442-8003
 Fax (626) 442-8315

To: Swinerton Builders

Ticket #: 10770

Date: 10/6/2016

Order Taken By: Cale Stevenson

Job Number: 16-043

Job Name: Lemonwood Elementary

Job Location: Oxnard CA

Customer Ref. Number: _____

COR # 4

| Description of Work | | | | Equipment | | | |
|--|--------------------|------------|---------------|------------------------------|-------|-----------|-------------------|
| | | | | Description | Hours | Bare Rate | Amount |
| Pothole to locate existing sewer and water lines that feed four portable classrooms so that lines can be rerouted away from construction. Sewer is located. Water is located in several areas. | | | | (Unit 104) Excavator 9060 | | \$207.14 | |
| | | | | (Unit 100) Excavator 9050 | | \$171.13 | |
| | | | | (Unit 102) Excavator EX300 | | \$143.86 | |
| | | | | (Unit 101) Excavator MEX 200 | | \$86.00 | |
| | | | | (Unit 103) Excavator CX 240 | | \$118.00 | |
| | | | | (Unit 105) Excavator PC128 | | \$65.00 | |
| | | | | Excavator Mini | | \$50.00 | |
| | | | | Loader 721 | | \$91.17 | |
| | | | | Loader 821/938 | | \$111.44 | |
| | | | | Loader 521 | | \$70.00 | |
| | | | | Backhoe | | \$58.00 | |
| | | | | Water Truck (2,000gal) | | \$50.98 | |
| | | | | Dump Truck (10cy)(Operated) | | \$85.00 | |
| | | | | Dump Truck (6cy) | | \$50.98 | |
| | | | | Utility Truck w/ Fuel Tank | 4 | \$33.46 | \$133.84 |
| | | | | Pick Up Truck | 8 | \$27.33 | \$218.64 |
| | | | | Super 10 Dump Truck | | \$95.00 | |
| | | | | Air Compressor w/ tools | | \$21.23 | |
| | | | | Saw Truck | | \$65.00 | |
| | | | | Bobcat Skid Steer | | \$29.13 | |
| Total Equipment | | | | | | | \$352.00 |
| Material/ Outside Services | | | | Subcontractor Charges | | | |
| Qty | Description | Unit Price | Amount | | | | |
| 1 | Sunbelt # 63915500 | 986.00 | 986.00 | Total Subcontractor | | | |
| | | | | Labor Rates thru MM/DD/YY | | | |
| | | | | Description | Hours | Rate | Amount |
| | | | | Operator | 8 | \$81.99 | \$655.92 |
| | | | | Operator Foreman | 8 | \$89.32 | \$714.56 |
| | | | | Laborer | 16 | \$63.04 | \$1,008.64 |
| | | | | Carpenter | | \$68.53 | |
| | | | | Cement Mason | | \$66.77 | |
| | | | | Operator Foreman O.T. | 0.5 | \$117.66 | \$58.83 |
| | | | | Operator O.T. | | \$108.77 | |
| | | | | Laborer O.T. | | \$83.34 | |
| | | | | Carpenter O.T. | | \$92.70 | |
| | | | | Cement Mason O.T. | | \$86.84 | |
| | | | | Laborer Foreman 2x O.T. | | \$130.57 | |
| | | | | Operator 2x O.T. | | \$135.56 | |
| | | | | Laborer 2x O.T. | | \$103.64 | |
| | | | | Carpenter 2x O.T. | | \$116.87 | |
| | | | | Cement Mason 2x O.T. | | \$106.91 | |
| Total Labor | | | | | | | \$2,438.00 |
| Total Labor | | | | | | | \$2,438.00 |
| Total Materials | | | | | | | \$986.00 |
| Total Equipment | | | | | | | \$352.00 |
| Total Subcontractor | | | | | | | |
| Mark-up Labor | | | | | | 15% | \$366.00 |
| Mark-up Materials | | | | | | 15% | \$148.00 |
| Mark-Up Equipment | | | | | | 15% | \$53.00 |
| Mark-up Subcontractor | | | | | | 5% | |
| Subtotal | | | | | | | \$4,343.00 |
| Bond | | | | | | | |
| Total | | | | | | | \$4,343.00 |
| Total Material | | | 986.00 | | | | |

Bali Construction, Inc.

Extra Work Ticket

(Ticket #) **10770**

Job Name: Lemonwood E1

Date: 10/6/16

Contractor: Swinerton

Ball Foreman: Cale Stevenson

GC Tracking Number: _____

Ball Job Number: 16-043

Work Completed: Yes ___ No X

Ball Job Name: _____

Description of Extra Work Being Performed
 Area - Future MPR Pothole to locate existing sewer and water lines that feed four portable classrooms so that lines can be rerouted away from construction. Sewer is located. Water is located in several areas.

| Ball Yard Stock Material | | | | Ball Equipment | | | | |
|--|----------------------------------|-------------------------------|--------------------|----------------------------|------------|----------|-----------|----|
| Qty | Description of Material Provided | Description | Unit # | Qty | Hours | | | |
| | | Ball Super Ten - Deliveries | | | | | | |
| | | Excavator | | | | | | |
| | | Mini Excavator <u>Sunbelt</u> | | <u>1</u> | <u>8</u> | | | |
| | | Compaction Wheel - excavators | | | | | | |
| | | Loader | | | | | | |
| Vendor Provided Material | | | | Ball Equipment | | | | |
| Qty | Vendor Name | Description of Material | Shipping/Invoice # | Description | Unit # | Qty | Hours | |
| | | | | Bobcat Skid Steer | | | | |
| | | | | Backhoe | | | | |
| | | | | Compaction Wheel - Backhoe | | | | |
| | | | | Backhoe - Breaker | | | | |
| | | | | Water Truck (2,000 gal) | | | | |
| | | | | Air Compressor w/ Tools | | | | |
| | | | | Pick UP Truck | <u>A9</u> | <u>1</u> | <u>8</u> | |
| | | | | Utility Truck W/ Fuel Tank | <u>A17</u> | <u>1</u> | <u>4</u> | |
| | | | | Sawcut Truck | | | | |
| | | | | Cones / Delineators | | | | |
| | | | | Traffic Signs | | | | |
| Rental Equipment & Outside Vendors & Misc. | | | | Ball Equipment | | | | |
| Qty | Vendor Name | Description of Material | Shipping/Invoice # | Description | Unit # | Qty | Hours | |
| | | | | Arrow Boards | | | | |
| | | | | Light Tower | | | | |
| <u>1</u> | <u>Sunbelt Rentals</u> | <u>Kubota Mini Exc</u> | <u>63915300</u> | Yard Truck Delivery | | | | |
| | | | | Labor | | | | |
| | | | | Names | Class | Reg | OT | DT |
| | | | | <u>Cale Stevenson</u> | <u>OF</u> | <u>8</u> | <u>.5</u> | |
| | | | | <u>Dave Tabacco</u> | <u>O</u> | <u>8</u> | | |
| | | | | <u>Alex Contreras</u> | <u>L</u> | <u>8</u> | | |
| | | | | <u>Raul Hernandez</u> | <u>L</u> | <u>4</u> | | |
| | | | | <u>Rafael Beltian</u> | <u>L</u> | <u>4</u> | | |
| Subcontractor Charges | | | | | | | | |
| Qty | Vendor Name | Description of Material | Shipping/Invoice # | | | | | |
| | | | | | | | | |

OF = Operator Foreman LF = Laborer Foreman CF = Carpenter Foreman CMF = Cement Mason Foreman
 O = Operator L = Laborer C = Carpenter CM = Cement Mason

Company: SWINERTON

Ball Foreman: Cale Stevenson

Signature: [Signature] Date: 10/6/16

Signature: [Signature] Date: 10/6/16

Print Name: CHRIS BURGESS Title: SUPERINTENDENT



| | |
|--------------|--------------|
| INVOICE NO. | 63915500-001 |
| ACCOUNT NO. | 76892 |
| INVOICE DATE | 10/13/16 |
| PAGE 1 | |

INVOICE TO
 BALI CONSTRUCTION INC
 9852 E. JOE VARGAS WAY
 SOUTH EL MONTE, CA 91733

JOB ADDRESS
 BALI CONSTRUCTION INC
 2200 CARNEGIE COURT
 LEMONWOOD SCHOOL
 OXNARD, CA 93033 4038
 C#: 626-442-8003 J#: 626-890-7920

| | |
|--|---------------------------------|
| RECEIVED BY Stevenson, Cale | CONTRACT NO. 63915500 |
| PURCHASE ORDER NO. JOB#16-043 | |
| JOB NO. 16-043 | |
| BRANCH 763 VENTURA NORTH CA PC763 320 W STANLEY AVENUE VENTURA, CA 93001 805-643-0996 | |

| QTY | EQUIPMENT # | Min | Day | Week | 4 Week | Amount |
|-----|-------------|-----|-----|------|--------|--------|
|-----|-------------|-----|-----|------|--------|--------|

| | | | | | | |
|---|--|--------|--------|--------|---------|--------|
| 1 | 9,500LB MINI EXCAVATOR 652496 Make: KUBOTA Model: U35-4R1 Ser #: N-10574 HR OUT: 951.100 HR IN: 956.000 TOTAL: 4.900 Billed from 10/06/16 thru 10/11/16 | 265.50 | 265.50 | 733.50 | 1867.50 | 733.50 |
| 1 | 24" COMPACT EXCAVATOR BUCKET | | | | | N/C |

Rental Sub-total: 733.50

| SALES | ITEMS: | Qty | Item number | Unit | Price | Amount |
|-------|--------------------------|-----|-------------|------|--------|--------|
| | DLPKSRCHG | 1 | | EA | 15.300 | 15.30 |
| | TRANSPORTATION SURCHARGE | | | | | N/C |
| | RETURNED FULL | 1 | RF | EA | | N/C |
| | DELIVERY CHARGE | | | | | 85.00 |
| | PICKUP CHARGE | | | | | 85.00 |

A discount of \$81.50 has been applied.
 FINAL BILL: 10/06/16 08:00 AM THRU 10/11/16 06:30 AM.

918.80

NET DUE UPON RECEIPT

| | |
|---------------|--------|
| SUBTOTAL | 918.80 |
| TAX | 66.70 |
| INVOICE TOTAL | 985.50 |

Extra Work

Bali Construction, Inc

9852 E. Joe Vargas Way
 So. El Monte, Ca 91733
 Telephone (626) 442-8003
 Fax (626) 442-8315

To: Swinerton Builders

Ticket #: 10771
 Date: 10/7/2016
 Order Taken By: Cale Stevenson
 Job Number: 16-043
 Job Name: Lemonwood Elementary
 Job Location: Oxnard CA
 Customer Ref. Number: _____
 COR # 4

| Description of Work | | | | Equipment | | | |
|---|------------------------------|------------|----------|------------------------------|-------|-----------|--------------|
| | | | | Description | Hours | Bare Rate | Amount |
| Complete potholing of water. Begin to lay rerouted sewer and water. Excavate across fire access gate and tie in sewer. Complete reroute of sewer. | | | | (Unit 104) Excavator 9060 | | \$207.14 | |
| | | | | (Unit 100) Excavator 9050 | | \$171.13 | |
| | | | | (Unit 102) Excavator EX300 | | \$143.86 | |
| | | | | (Unit 101) Excavator MEX 200 | | \$86.00 | |
| | | | | (Unit 103) Excavator CX 240 | | \$118.00 | |
| | | | | (Unit 105) Excavator PC128 | | \$65.00 | |
| | | | | Excavator Mini | | \$50.00 | |
| | | | | Loader 721 | | \$91.17 | |
| | | | | Loader 821/938 | | \$111.44 | |
| | | | | Loader 521 | | \$70.00 | |
| | | | | Backhoe | | \$58.00 | |
| | | | | Water Truck (2,000gal) | | \$50.98 | |
| | | | | Dump Truck (10cy)(Operated) | | \$85.00 | |
| | | | | Dump Truck (6cy) | | \$50.98 | |
| | | | | Utility Truck w/ Fuel Tank | 8 | \$33.46 | \$267.68 |
| | | | | Pick Up Truck | 8 | \$27.33 | \$218.64 |
| | | | | Super 10 Dump Truck | | \$95.00 | |
| | | | | Air Compressor w/ tools | | \$21.23 | |
| | | | | Saw Truck | | \$65.00 | |
| | | | | Bobcat Skid Steer | | \$29.13 | |
| | | | | Total Equipment | | | \$486.00 |
| Material/ Outside Services | | | | Subcontractor Charges | | | |
| Qty | Description | Unit Price | Amount | | | | |
| 1 | Western Water Works # 432562 | 2,023.00 | 2,023.00 | Total Subcontractor | | | |
| | | | | Labor Rates thru MM/DD/YY | | | |
| | | | | Description | Hours | Rate | Amount |
| | | | | Operator | 8 | \$81.99 | \$655.92 |
| | | | | Operator Foreman | 8 | \$89.32 | \$714.56 |
| | | | | Laborer | 24 | \$63.04 | \$1,512.96 |
| | | | | Carpenter | | \$68.53 | |
| | | | | Cement Mason | | \$66.77 | |
| | | | | Operator Foreman O.T. | 0.5 | \$117.66 | \$58.83 |
| | | | | Operator O.T. | | \$108.77 | |
| | | | | Laborer O.T. | | \$83.34 | |
| | | | | Carpenter O.T. | | \$92.70 | |
| | | | | Cement Mason O.T. | | \$86.84 | |
| | | | | Laborer Foreman 2x O.T. | | \$130.57 | |
| | | | | Operator 2x O.T. | | \$135.56 | |
| | | | | Laborer 2x O.T. | | \$103.64 | |
| | | | | Carpenter 2x O.T. | | \$116.87 | |
| | | | | Cement Mason 2x O.T. | | \$108.91 | |
| | | | | Total Labor | | | \$2,942.00 |
| | | | | Total Labor | | | \$2,942.00 |
| | | | | Total Materials | | | \$2,023.00 |
| | | | | Total Equipment | | | \$486.00 |
| | | | | Total Subcontractor | | | |
| | | | | Mark-up Labor | | | 15% \$441.00 |
| | | | | Mark-up Materials | | | 15% \$303.00 |
| | | | | Mark-Up Equipment | | | 15% \$73.00 |
| | | | | Mark-up Subcontractor | | | 5% |
| | | | | Subtotal | | | \$6,268.00 |
| | | | | Bond | | | |
| | | | | Total | | | \$6,268.00 |
| Total Material | | | 2,023.00 | | | | |

Bali Construction, Inc.

Extra Work Ticket

(Ticket #) 10771

Job Name: Lemonwood E1
 Contractor: Swinerton

Date: 10/7/16

Bali Foreman: Cale Stevenson

GC Tracking Number: _____

Bali Job Number: 16-043

Work Completed: Yes No

Bali Job Name: _____

Description of Extra Work Being Performed

Area Future MPR - Complete potholing of water. Begin to lay rerouted sewer & water. Excavate across fire access gate and tie in sewer. Complete reroute of sewer.

Bali Yard Stock Material

Bali Equipment

| Qty | Description of Material Provided | Description | Unit # | Qty | Hours |
|-----|----------------------------------|--|--------|-----|-------|
| | | Bali Super Ten - Deliveries | | | |
| | | Excavator | | | |
| | | Mini Excavator <u>Sonbelt</u> | | 1 | 8 |
| | | Compaction Wheel - excavator <u>63915300</u> | | | |
| | | Loader | | | |

Vendor Provided Material

| Qty | Vendor Name | Description of Material | Shipping/Invoice # | Description | Unit # | Qty | Hours |
|-----|-------------|----------------------------------|--------------------|----------------------------|------------|-----|-------|
| | <u>WWW</u> | <u>Temp Sewer/Water material</u> | <u>432562</u> | Backhoe | | | |
| | | | | Compaction Wheel - Backhoe | | | |
| | | | | Backhoe - Breaker | | | |
| | | | | Water Truck (2,000 gal) | | | |
| | | | | Air Compressor w/ Tools | | | |
| | | | | Pick UP Truck | <u>A9</u> | 1 | 8 |
| | | | | Utility Truck W/ Fuel Tank | <u>A17</u> | 1 | 8 |
| | | | | Sawcut Truck | | | |
| | | | | Cones / Delineators | | | |
| | | | | Traffic Signs | | | |

Rental Equipment & Outside Vendors & Misc.

| Qty | Vendor Name | Description of Material | Shipping/Invoice # | Description | Unit # | Qty | Hours |
|-----|-------------|-------------------------|--------------------|---------------------|--------|-----|-------|
| | | | | Arrow Boards | | | |
| | | | | Light Tower | | | |
| | | | | Yard Truck Delivery | | | |

Labor

| Names | Class | Reg | OT | DT |
|-----------------------|-----------|----------|-----------|----|
| <u>Cale Stevenson</u> | <u>OF</u> | <u>8</u> | <u>.5</u> | |
| <u>Dave Tabacco</u> | <u>O</u> | <u>8</u> | | |
| <u>Raul Hernandez</u> | <u>L</u> | <u>8</u> | | |
| <u>Rafael Bettran</u> | <u>L</u> | <u>8</u> | | |
| <u>Alex Contreras</u> | <u>L</u> | <u>8</u> | | |

Subcontractor Charges

| Qty | Vendor Name | Description of Material | Shipping/Invoice # |
|-----|-------------|-------------------------|--------------------|
| | | | |

OF = Operator Foreman LF = Laborer Foreman CF = Carpenter Foreman CMF = Cement Mason Foreman
 O = Operator L = Laborer C = Carpenter CM = Cement Mason

Company: Swinerton
 Signature: [Signature]
 Print Name: Chris B...
 Title: Superintendent
 Date: 10/11/16

Bali Foreman: Cale Stevenson
 Signature: [Signature]
 Date: 10/7/16



WESTERN WATER WORKS
 SUPPORT CENTER
 5831 PINE AV
 CHINO HILLS, CA - 91709
 PHONE: (909)597-7000 FAX: (909)597-7050

INVOICE

| | | |
|-----------|--------------|-------------|
| QUOTE NO. | INVOICE DATE | INVOICE NO. |
| 0 | 10/10/16 | 432562-00 |
| P.O. DATE | P.O. NUMBER | PAGE NO. |
| 10/06/16 | 16-043 | 1 of 1 |



CUST #: 2040

BILL TO: BALI CONST INC
 9852 E JOE VARGAS WY
 S EL MONTE, CA 91733-3095

SHIP TO: BALI CONST INC

OXNARD, CA

| INSTRUCTIONS | SHIP POINT | VIA | SHIPPED | TERMS |
|--------------|----------------------|-----------|----------|-------------|
| CALE | SEL - S EL MONTE, CA | WILL CALL | 10/07/16 | NET 30 DAYS |

| PRODUCT AND DESCRIPTION | ORDERED | BO | SHIPPED | UM | PRICE | UM | DISCOUNT | NET AMOUNT |
|---|---------|-------------------|---------|----|-----------|---------------|----------|------------|
| 1 SCH40-02 | 660 | 0 | 660 | FT | 1.50 | FT | 0.00 | 990.00 |
| 2 SCH40 PVC PIPE | | | | | | | | |
| 2 406-020 | 18 | 0 | 18 | EA | 1.92500 | EA | 0.00 | 34.65 |
| 2 SCH40 90 BEND SXS | | | | | | | | |
| 3 401-020 | 8 | 0 | 8 | EA | 2.37500 | EA | 0.00 | 19.00 |
| 2 PVC TEE SOC SCH40 | | | | | | | | |
| 5 417-020 | 2 | 0 | 2 | EA | 2.25 | EA | 0.00 | 4.50 |
| 2 SCH40 45 BEND SXS | | | | | | | | |
| 6 447-020# | 1 | 0 | 1 | EA | 0.85 | EA | 0.00 | 0.85 |
| 2 CAP S SCH40 | | | | | | | | |
| 7 436-020 | 2 | 0 | 2 | EA | 1.22500 | EA | 0.00 | 2.45 |
| 2 SCH40 PVC ADAPTER MIPXS | | | | | | | | |
| 8 438-248# | 4 | 0 | 4 | EA | 1.77500 | EA | 0.00 | 7.10 |
| 2 X 3/4 BUSHING SXT SCH40 | | | | | | | | |
| 9 RHBG | 2 | 0 | 2 | EA | 21.53550 | EA | 0.00 | 43.07 |
| BLUE MEDIUM BODIED FAST SETTING GLUE 1 PT | | | | | | | | |
| 10 BIB-075M | 4 | 0 | 4 | EA | 12.80 | EA | 0.00 | 51.20 |
| 3/4 HOSE BIB MIP NO KINK | | | | | | | | |
| 12 VXEBV108# | 4 | 0 | 4 | EA | 135.13333 | EA | 0.00 | 540.53 |
| 2 SCH80 PVC TRUE UNION BALL VLV EPDM | | | | | | | | |
| 13 K15-101-0302# | 2 | 0 | 2 | EA | 29.16333 | EA | 0.00 | 58.33 |
| 1-1/2" X 2" MALE ADAPT. CXM | | | | | | | | |
| 14 CMA-02 | 1 | 0 | 1 | EA | 29.00 | EA | 0.00 | 29.00 |
| 2 COPPER MALE ADAPTER SXMIP | | | | | | | | |
| 15 156-22# | 8 | 0 | 8 | EA | 5.10 | EA | 0.00 | 40.80 |
| 2" SEWER CPLG CI/PVC X CI/PVC | | | | | | | | |
| 16 SC24X3 | 2 | 0 | 2 | EA | 12.58 | EA | 0.00 | 25.16 |
| 2 STD X 3 SNAP ON CLAMP 2.38 IPS | | | | | | | | |
| 14 Lines Total | | Qty Shipped Total | 718 | | | Total | | 1846.64 |
| | | | | | | Taxes | | 175.43 |
| | | | | | | Invoice Total | | 2022.07 |

You are a Grand Guarantee Club Member.
 We Guarantee:
 - Accurate Orders
 - Accurate Billings
 - Accurate Delivery Times
 Or we will give you \$1000

Extra Work

Bali Construction, Inc

9852 E. Joe Vargas Way
 So. El Monte, Ca 91733
 Telephone (626) 442-8003
 Fax (626) 442-8315

Ticket #: 10772

Date: 10/10/2016

Order Taken By: Cale Stevenson

Job Number: 16-043

Job Name: Lemonwood Elementary

Job Location: Oxnard CA

Customer Ref. Number:

COR # 4

To: Swinerton Builders

| Description of Work | | | | Equipment | | | |
|---|--------------------------|------------|--------------|------------------------------|-------|-----------|-----------------|
| | | | | Description | Hours | Bare Rate | Amount |
| Area- Future MPR complete reroute of water ready to tie in. | | | | (Unit 104) Excavator 9060 | | \$207.14 | |
| | | | | (Unit 100) Excavator 9050 | | \$171.13 | |
| | | | | (Unit 102) Excavator EX300 | | \$143.86 | |
| | | | | (Unit 101) Excavator MEX 200 | | \$86.00 | |
| | | | | (Unit 103) Excavator CX 240 | | \$118.00 | |
| | | | | (Unit 105) Excavator PC128 | | \$65.00 | |
| | | | | Excavator Mini | | \$50.00 | |
| | | | | Loader 721 | | \$91.17 | |
| | | | | Loader 821/938 | | \$111.44 | |
| | | | | Loader 521 | | \$70.00 | |
| | | | | Backhoe | | \$58.00 | |
| | | | | Water Truck (2,000gal) | | \$50.98 | |
| | | | | Dump Truck (10cy)(Operated) | | \$65.00 | |
| | | | | Dump Truck (6cy) | | \$50.98 | |
| | | | | Utility Truck w/ Fuel Tank | | \$33.46 | |
| | | | | Pick Up Truck | | \$27.33 | |
| | | | | Super 10 Dump Truck | | \$95.00 | |
| | | | | Air Compressor w/ tools | | \$21.23 | |
| | | | | Saw Truck | | \$65.00 | |
| | | | | Bobcat Skid Steer | | \$29.13 | |
| | | | | Total Equipment | | | |
| Material/ Outside Services | | | | Subcontractor Charges | | | |
| Qty | Description | Unit Price | Amount | | | | |
| | Lowes Receipt # 51734061 | 38.00 | 38.00 | Total Subcontractor | | | |
| | | | | Labor Rates thru MM/DD/YY | | | |
| | | | | Description | Hours | Rate | Amount |
| | | | | Operator | 2 | \$81.99 | \$163.98 |
| | | | | Operator Foreman | 2 | \$89.32 | \$178.64 |
| | | | | Laborer | 6 | \$63.04 | \$378.24 |
| | | | | Carpenter | | \$68.53 | |
| | | | | Cement Mason | | \$66.77 | |
| | | | | Operator Foreman O.T. | | \$117.66 | |
| | | | | Operator O.T. | | \$108.77 | |
| | | | | Laborer O.T. | | \$83.34 | |
| | | | | Carpenter O.T. | | \$92.70 | |
| | | | | Cement Mason O.T. | | \$86.84 | |
| | | | | Laborer Foreman 2x O.T. | | \$130.57 | |
| | | | | Operator 2x O.T. | | \$135.56 | |
| | | | | Laborer 2x O.T. | | \$103.64 | |
| | | | | Carpenter 2x O.T. | | \$116.87 | |
| | | | | Cement Mason 2x O.T. | | \$106.91 | |
| | | | | Total Labor | | | \$721.00 |
| | | | | Total Labor | | | \$721.00 |
| | | | | Total Materials | | | \$38.00 |
| | | | | Total Equipment | | | |
| | | | | Total Subcontractor | | | |
| Total Material | | | 38.00 | Mark-up Labor | | | 15% \$108.00 |
| | | | | Mark-up Materials | | | 15% \$6.00 |
| | | | | Mark-Up Equipment | | | 15% |
| | | | | Mark-up Subcontractor | | | 5% |
| | | | | Subtotal | | | \$873.00 |
| | | | | Bond | | | |
| | | | | Total | | | \$873.00 |

Bali Construction, Inc.

Extra Work Ticket

(Ticket #) 10772

Job Name: Lemonwood E1
 Contractor: Swinerton

Date: 10/10/16
 Ball Foreman: Cale Stevenson

GC Tracking Number: _____
 Work Completed: Yes ___ No

Ball Job Number: 16-043
 Ball Job Name: _____

Description of Extra Work Being Performed
Open Area - Future MPR Complete reroute of water, ready to tie in.

| Ball Yard Stock Material | | Ball Equipment | | | |
|--------------------------|----------------------------------|-------------------------------|--------|-----|-------|
| Qty | Description of Material Provided | Description | Unit # | Qty | Hours |
| | | Ball Super Ten - Deliveries | | | |
| | | Excavator | | | |
| | | Mini Excavator | | | |
| | | Compaction Wheel - excavators | | | |
| | | Loader | | | |

| Vendor Provided Material | | | | Ball Equipment | |
|--------------------------|--------------|------------------------------------|--------------------|----------------------------|-------|
| Qty | Vendor Name | Description of Material | Shipping/Invoice # | Description | Hours |
| | <u>Lowes</u> | <u>Temp water material Fitting</u> | <u>51734067</u> | Backhoe | |
| | | | | Compaction Wheel - Backhoe | |
| | | | | Backhoe - Breaker | |
| | | | | Water Truck (2,000 gal) | |
| | | | | Air Compressor w/ Tools | |
| | | | | Pick UP Truck | |
| | | | | Utility Truck W/ Fuel Tank | |
| | | | | Sawcut Truck | |
| | | | | Cones / Delinators | |
| | | | | Traffic Signs | |

| Rental Equipment & Outside Vendors & Misc. | | | | Ball Equipment | |
|--|-------------|-------------------------|--------------------|---------------------|-------|
| Qty | Vendor Name | Description of Material | Shipping/Invoice # | Description | Hours |
| | | | | Arrow Boards | |
| | | | | Light Tower | |
| | | | | Yard Truck Delivery | |

| Labor | | | | | |
|-----------------------|-----------|----------|----|----|--|
| Names | Class | Reg | OT | DT | |
| <u>Cale Stevenson</u> | <u>OF</u> | <u>2</u> | | | |
| <u>Dave Tabacco</u> | <u>O</u> | <u>2</u> | | | |
| <u>Raul Hernandez</u> | <u>L</u> | <u>2</u> | | | |
| <u>Rosari Beltran</u> | <u>L</u> | <u>2</u> | | | |
| <u>Alex Contreras</u> | <u>L</u> | <u>2</u> | | | |

| Subcontractor Charges | | | |
|-----------------------|-------------|-------------------------|--------------------|
| Qty | Vendor Name | Description of Material | Shipping/Invoice # |
| | | | |

OF = Operator Foreman LF = Laborer Foreman CF = Carpenter Foreman CMF = Cement Mason Foreman
 O = Operator L = Laborer C = Carpenter CM = Cement Mason
 Ball Foreman: Cale Stevenson

Company: SWINERTON
 Signature: [Signature]
 Print Name: Chris Burdick
 Title: SUPERINTENDENT

Signature: [Signature] Date: 10/10/16

For returns with valid receipts, see your return.
 Cash if your purchase was made with cash or debit card.
 In-store credit if your purchase was made with a check here from 9 days ago.

may
 be
 with

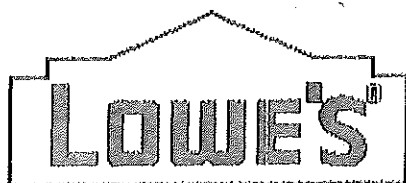

LOWE'S HOME CENTERS, LLC
 500 SOUTH HILLS ROAD
 VENTURA, CA 93003 (805) 675-8000

me
 u
 s

- SALE -

SALES#: S1734001 1378462 TRANS#: 20949476 10-00-16

| | | |
|--------|---------------------------|-------|
| 23982 | 1-1/4-IN X 5-FT SCH40 PIP | 3.89 |
| 141566 | 2-IN SCH40 UNION 450-020 | 0.37 |
| 23860 | 1-1/4-IN SCH40 ADPTR 4360 | 1.96 |
| | 2 @ 0.96 | |
| 51240 | 1-1/4-IN CXH COPPER ADAPT | 11.98 |
| 22711 | 1-1/4-IN SCH40 ELDBU 4070 | 1.38 |
| 23922 | 2-IN X 1-1/2-IN SCH40 | 1.98 |
| 16765 | 1-1/4-IN PVC UNION IPS SC | 4.98 |

| | |
|----------------------|-------|
| SUBTOTAL: | 34.54 |
| TAX: | 2.59 |
| INVOICE 20174 TOTAL: | 37.13 |
| CASH: | 40.00 |
| CHARGE: | 2.87 |

STORE: 1734 TERMINAL: 20 10/08/16 10:58:05
 # OF ITEMS PURCHASED: 8
 EXCLUDES FEES, SERVICES AND SPECIAL ORDER ITEMS



THANK YOU FOR SHOPPING LOWE'S.
 SEE REVERSE SIDE FOR RETURN POLICY.
 STORE MANAGER: WILL FINSTER

WE HAVE THE LOWEST PRICES, GUARANTEED!
 IF YOU FIND A LOWER PRICE, WE WILL BEAT IT BY 10%.
 SEE STORE FOR DETAILS.

 YOUR ORDER NUMBER

Bali Construction, Inc.

Extra Work Ticket

(Ticket #) 14491

Job Name: Lemonwood E1

Date: 10/25/16

Contractor: Swinerton

Bali Foreman: Cale Stevenson

GC Tracking Number: _____

Bali Job Number: 16-043

Work Completed: Yes No

Bali Job Name: Lemonwood E1

Description of Extra Work Being Performed
Outside of MPR - Perform final tie in of temp water (2" Sch 40) to existing 2" copper (North) and 1/4" (South) after facilities shuts water down.

Ball Yard Stock Material **Ball Equipment**

| Qty | Description of Material Provided | Description | Unit # | Qty | Hours |
|-----|----------------------------------|-------------------------------|--------|-----|-------|
| | | Ball Super Ten - Deliveries | | | |
| | | Excavator | | | |
| | | Mini Excavator | | | |
| | | Compaction Wheel - excavators | | | |
| | | Loader | | | |

Vendor Provided Material

| Qty | Vendor Name | Description of Material | Shipping/Invoice # | Description | Unit # | Qty | Hours |
|-----|-------------|-------------------------|--------------------|----------------------------|--------|-----|-------|
| | | | | Bobcat Skid Steer | | | |
| | | | | Backhoe | | | |
| | | | | Compaction Wheel - backhoe | | | |
| | | | | Backhoe - Breaker | | | |
| | | | | Water Truck (2,000 gal) | | | |
| | | | | Air Compressor w/ Tools | | | |
| | | | | Pick UP Truck | 49 | 1 | 3 |
| | | | | Utility Truck W/ Fuel Tank | 417 | 1 | 3 |
| | | | | Sawcut Truck | | | |
| | | | | Cones / Delineators | | | |
| | | | | Traffic Signs | | | |

Rental Equipment & Outside Vendors & Misc.

| Qty | Vendor Name | Description of Material | Shipping/Invoice # | Description | Unit # | Qty | Hours |
|-----|-------------|-------------------------|--------------------|---------------------|--------|-----|-------|
| | | | | Arrow Boards | | | |
| | | | | Light Tower | | | |
| | | | | Yard Truck Delivery | | | |

Labor

| Names | Class | Reg | OT | DT |
|----------------|-------|-----|-----|----|
| Cale Stevenson | OF | 1.5 | 1.5 | |
| Raul Hernandez | L | 1.5 | 1.5 | |
| Roscoe Beltram | L | 1.5 | 1.5 | |
| Alex Contreras | L | 1.5 | 1.5 | |

Subcontractor Charges

| Qty | Vendor Name | Description of Material | Shipping/Invoice # | Description | Unit # | Qty | Hours |
|-----|-------------|-------------------------|--------------------|-------------|--------|-----|-------|
| | | | | | | | |

OF = Operator Foreman LF = Laborer Foreman CF = Carpenter Foreman CMF = Cement Mason Foreman
 O = Operator L = Laborer C = Carpenter CM = Cement Mason

Company: SWINERTON BUILDERS
 Signature: Chris Barbato Date: 10/25/16
 Print Name: CHRIS BARBATO Title: SUPERINTENDENT

Bali Foreman: Cale Stevenson
 Signature: Cale Stevenson Date: 10/25/16

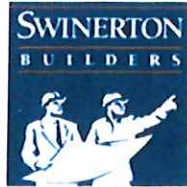

October 26, 2016

Oxnard School District
1051 South A Street
Oxnard, CA, 93030

Attn: Ms. Marlene Hickle/Greg Grant - CFW

Subject: Swinerton Builders Job 16055106 - Lemonwood K-8 School LLB
PCI No. 0072 Finish Hardware changes

Dear Ms. Hickle and Mr. Grant,

We request a Change Order to our contract for the following:

Submittal review comments came back changing the specified manufacturer from Sargent to Schlage

| Phase | Category | Description | Subcontractor | Quote |
|--------|----------|-----------------------------------|------------------------|------------------|
| 081000 | 71140 | Door Hardware Manufacturer Change | Star Hardware, Inc. | 41,951.25 |
| | | | Subtotal | 41,951.25 |
| 007480 | 71160 | Subguard | 1.15% | 482.44 |
| 007410 | 71160 | Builders Risk | 0.6% | 254.60 |
| 007420 | 71160 | General Insurance | 1.15% | 487.99 |
| 007510 | 71160 | P&P Bond | 1% | 419.51 |
| 991000 | 79999 | Change Order Fee | 15% | 6,476.44 |
| | | | Markup Subtotal | 8,120.98 |
| | | | PCI Total | 50,072.23 |

TOTAL AMOUNT OF THIS CHANGE ORDER REQUEST: **50,072.23**.

Please NOTE:

- » The incorporation of this revision in to the contractual scope of work may have an impact on our schedule, which is yet to be finalized. Once determined, the job schedule will be adjusted accordingly to show the effect of this revision on the final project completion date.
- » The terms (cost and schedule impact) of this change order request are subject to review and a requote if not accepted within days of its issuance.
- » This request does not include additional cost or delay due to late approval.

We **HAVE NOT** proceeded with this revised work per your instructions. Please issue a change order.



Upon acceptance of this change order request, a formal change order will be issued. Acceptance also acknowledges that Swinerton Builders is directed to proceed with the above change in scope.

If you have any questions or comments pertaining to this matter, please contact the undersigned.

Sincerely,
Swinerton Builders

A handwritten signature in blue ink, appearing to read "Bill Gray", is written over the printed name.

Bill Gray
PM

Date: 10/26/2016

Quotation accepted by:
Oxnard School District

By: _____

Date: _____

Finish Hardware Schedule

for

Page 1 of 40
8/25/2016 2:13

Lemonwood K-8 Reconstruction
2000 Carnegie Court
Oxnard, CA 93033

Architect: SVA Architects
3 MacArthur Pl
Suite 850
Santa Ana, CA 92707

(949)809-3380

Contractor: Swinerton Builders
865 S. Figueroa Street
Suite 3000
Los Angeles, CA 90017

Supplier: Star Hardware, Inc.
8727 Lanyard Court
Rancho Cucamonga, CA 91730
(909)481-7331 Fax# (909)481-7241

Prepared By: Tommy Gardner

Job Number: 5384

Date: August 25, 2016

| | |
|---|--|
| SVA Architects, Inc. | Submittal Number 087100-002 |
| ARCHITECTURE PLANNING INTERIORS GRAPHICS | Submittal Name Door Hardware |
| | Date 09.28.2016 |
| | Reviewed by TB |
| ARCHITECTURAL REVIEW: | |
| Review, comment or notation regarding the submitted material is for general conformance with information provided and design concept expressed in the Contract Documents. | |
| <input type="checkbox"/> FURNISH AS SUBMITTED | <input type="checkbox"/> REVIEWED FOR GENERAL DESIGN CONFORMANCE |
| <input checked="" type="checkbox"/> FURNISH AS CORRECTED | |
| <input type="checkbox"/> REVISE AND RESUBMIT | SUBSTITUTION ITEM: |
| <input type="checkbox"/> REJECTED | <input type="checkbox"/> SUBMIT REQUEST |
| <input type="checkbox"/> NOT SUBJECT TO REVIEW | <input type="checkbox"/> ADDITIONAL INFO REQ'D |
| | <input type="checkbox"/> SUBMIT SPECIFIED ITEM |

| | |
|--|--|
| SUBMITTAL REVIEWED: | |
| <input type="checkbox"/> Reviewed, No Corrections Necessary | |
| <input checked="" type="checkbox"/> Reviewed, Corrections Made | |
| <input type="checkbox"/> Reviewed, Resubmittal Requested | |
| <input type="checkbox"/> Not Reviewed, Resubmittal Requested | |
| <i>The review of shop drawings, product data, or samples is for general conformance only and shall not relieve the contractor/supplier of any deviation from the requirements of the contract documents, nor the responsibility for errors and omissions including (but not limited to) sizes, quantities, required parts, or locations.</i> | |
| Reviewed Date: 9/27/2016 | |
| Marc Schwartz Allegion, P.L.C. | |
|  ALLEGION | |

Finish Hardware Schedule

Lemonwood K-8 Reconstruction

Job Number: 5384

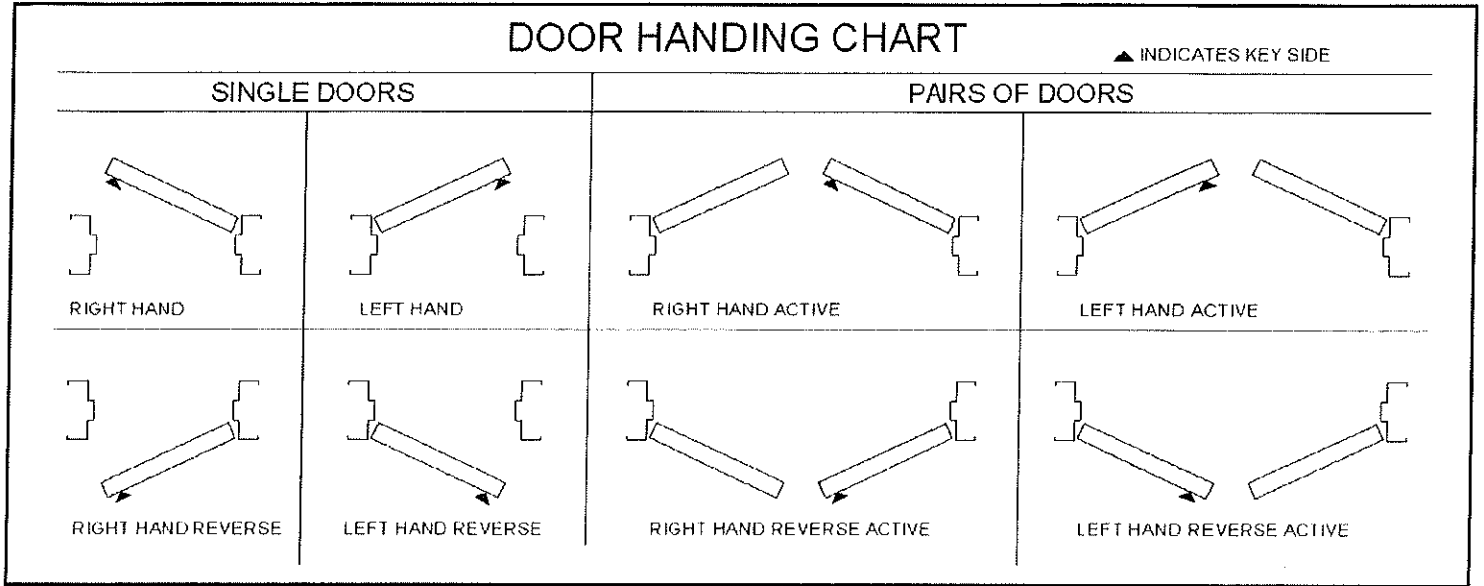

Finish Hardware Schedule

Lemonwood K-8 Reconstruction

Page 3 of 40

8/25/2016 2:13

Note: Permanent key system to be Schlage Everest 29T, non-interchangeable. Provide all locksets & cylinders with construction keying.

| | |
|----------------------|---|
| Job Number: 5384 | |
| Based On: | |
| Hinge - Continuous | Pemko (PEM) |
| Hinge | McKinney (MCK) |
| Automatic Flushbolt | Rockwood (ROC) |
| Dust Proof Strike | Rockwood (ROC) |
| Removable Mullion | Sargent (SAR) Provide Schlage locksets & keying. |
| Mortise Lockset | Sargent (SAR) Provide Schlage locksets & keying. |
| Mortise Passage | Sargent (SAR) Provide Schlage locksets & keying. |
| Mortise Privacy | Sargent (SAR) Provide Schlage locksets & keying. |
| Exit Device | Sargent (SAR) Provide Von Duprin . |
| Push Plate | Rockwood (ROC) |
| Pull Plate | Rockwood (ROC) |
| Anti-Vandal Pull | Rockwood (ROC) |
| Coordinator - Bar | Rockwood (ROC) |
| Door Closer | Sargent (SAR) |
| Closer | Sargent (SAR) |
| Mounting Bracket | Rockwood (ROC) |
| Kick Plate | Rockwood (ROC) |
| Mop Plate | Rockwood (ROC) |
| Wall Bumper | Rockwood (ROC) |
| Floor Stop | Rockwood (ROC) |
| Overhead Holder/Stop | Sargent (SAR) |
| Weatherstripping | Pemko (PEM) |
| Sweep Strip | Pemko (PEM) |
| Threshold | Pemko (PEM) |
| Drip Cap | Pemko (PEM) |

Finish Hardware Schedule
Lemonwood K-8 Reconstruction

Page 4 of 40
8/25/2016 2:13

Job Number: 5384

Gasketing

Pemko (PEM)

Silencer

Rockwood (ROC)



Star Hardware Inc.

8727 LANYARD COURT
 RANCHO CUCAMONGA, CA 91730
 (909) 481-7331 * (909) 481-7241 Fax

To: Swinerton Builders Date: October 24, 2016
 Project: _____
 STAR Job No.: 5383
 Phone: _____ COR No.: 01
 Fax: _____ Subject: REQUEST FOR CHANGE ORDER
 ATTN: Nalani Scanlon

DESCRIPTION:

THE FOLLOWING IS A COST TO CHANGE THE FINISH HARDWARE FROM THE SPECIFIED SARGENT LOCKSETS AND EXIT DEVICES TO SCHLAGE AND VON DUPRIN.

LABOR:

| | HOURS | | RATE/HR | | | |
|--------------|-------|---|---------|--|----|--------------------|
| INSTALLATION | | X | = | | \$ | - |
| | | | | | | LABOR TOTAL |
| | | | | | | \$ |
| | | | | | | - |

MATERIAL:

| | UNITS | | \$/UNIT | UM | | |
|---------------------------------------|-------|---|-----------|----|----|----------------|
| DELETE THE FOLLOWING | | | | | | |
| LOCKSET - 64 DGI 8238 LNL x US26D | 41 | X | (203.000) | | \$ | (8,323.00) |
| LOCKSET - 64 DGI 8206 LNL x US26D | 17 | X | (180.000) | | \$ | (3,060.00) |
| LOCKSET - 50-64 DGI 8250 LNL x US26D | 2 | X | (200.000) | | \$ | (400.00) |
| LOCKSET - 64 DGI 8237 LNL x US26D | 23 | X | (180.000) | | \$ | (4,140.00) |
| LOCKSET - LB 8265 LNL x US26D | 2 | X | (148.000) | | \$ | (296.00) |
| LOCKSET - 64 DGI 8204 LNL x US26D | 8 | X | (180.000) | | \$ | (1,440.00) |
| LOCKSET - 64 DGI LB 8205 LNL x US26D | 8 | X | (200.000) | | \$ | (1,600.00) |
| LOCKSET - 8215 LNL x US26D | 8 | X | (180.000) | | \$ | (1,440.00) |
| EXIT DEVICE - 43 16 8804F 649 x US26D | 21 | X | (435.000) | | \$ | (9,135.00) |
| EXIT DEVICE - 43 16 8810F 649 x US26D | 7 | X | (396.000) | | \$ | (2,772.00) |
| MULLION - L980 PC | 5 | X | (320.000) | | \$ | (1,600.00) |
| | | X | | | \$ | - |
| | | | | | | \$ (34,206.00) |

ADD THE FOLLOWING

| | | | | | | |
|--|----|---|-----------|--|----|--------------|
| LOCKSET - L9071P 06A L283-711 EVEREST 29T x US26D | 44 | X | 420.000 | | \$ | 18,480.00 |
| LOCKSET - L9070P 06A EVEREST 29T x US26D | 16 | X | 335.000 | | \$ | 5,360.00 |
| LOCKSET - L9080P LLL 06A L283-150 EVEREST 29T x US26D | 17 | X | 341.000 | | \$ | 5,797.00 |
| LOCKSET - L9080P 06A EVEREST 29T x US26D | 8 | X | 335.000 | | \$ | 2,680.00 |
| LOCKSET - L9485P 06A L583-363 L283-722 EVEREST 29T x US26D | 2 | X | 425.000 | | \$ | 850.00 |
| LOCKSET - L9456P 06A L583-363 EVEREST 29T x US26D | 8 | X | 355.000 | | \$ | 2,840.00 |
| LOCKSET - L9040 06A L583-363 x US26D | 3 | X | 296.000 | | \$ | 888.00 |
| LOCKSET - L9010 06A L583-363 x US26D | 8 | X | 243.000 | | \$ | 1,944.00 |
| EXIT DEVICE - PA AX CDSI 98 NL-OP 3' x US26D | 15 | X | 827.000 | | \$ | 12,405.00 |
| EXIT DEVICE - PA AX CDSI 98 EO 3' x US26D | 8 | X | 771.000 | | \$ | 6,168.00 |
| EXIT DEVICE - PA AX 98L-F 2SI 06 3' x US26D | 6 | X | 1,199.000 | | \$ | 7,194.00 |
| MULLION - KR4954 MT 54 7' | 5 | X | 544.000 | | \$ | 2,720.00 |
| RIM CYLINDER - 20-022 EVEREST 29T x US26D | 8 | X | 35.000 | | \$ | 280.00 |
| MORTISE CYLINDER - 20-002 EVEREST 29T x US26D | 10 | X | 35.000 | | \$ | 350.00 |
| ANTI VANDAL PULL - VRT-24 x CTC x US26D | 1 | X | 150.000 | | \$ | 150.00 |
| | | | | | | \$ 68,106.00 |

| | | | | | | |
|--|--|--|--|--|----|---|
| | | | | | \$ | - |
| | | | | | \$ | - |
| | | | | | \$ | - |
| | | | | | \$ | - |
| | | | | | \$ | - |
| | | | | | \$ | - |
| | | | | | \$ | - |

SUBCONTRACTOR TOTAL \$ 33,900.00

SUB-TOTAL \$ 33,900.00
SALES TAX 8.75% \$ 2,966.25
OH&P 15% \$ 5,085.00

TOTAL \$ 41,951.25



HUNTINGTON HARDWARE CO., INC.

340 West Holt Avenue
 Pomona, Ca. 91768-3105
 Phone (909) 629-5301 Fax (909) 620-8962

QUOTATION

QUOTATION NUMBER
 1071504-0000-01

QUOTATION NUMBER
 1071504-0000-01

STAHAR

BILL TO: STAR HARDWARE, INC.
 8727 LANYARD COURT
 R. CUCAMONGA CA 91730

SHIP TO: STAR HARDWARE, INC.
 8727 LANYARD COURT
 R. CUCAMONGA CA 91730

481-7331

CUSTOMER P.O.NO. LEMONWOOD

CUSTOMER P.O.NO. LEMONWOOD

QUOTATION**QUOTATION*****QUOTATION*****QUOTATION*****QUOTATION***

| QUOTATION NUMBER | SLSMN | ORDER DATE | TAKER | CUSTOMER P.O. NUMBER | DATE | |
|------------------|-------|------------|-------|----------------------|------|----------|
| 1071504-0000-01 | 146 | 10/24/16 | 150 | LEMONWOOD | | |
| INSTRUCTIONS | | | | | | |
| **WILL CALL** | | | | | FRT. | PAGE NO. |
| | | | | | B | 1 |

| QUANTITY | | | DISP. | ITEM CODE AND DESCRIPTION | U/M | UNIT PRICE | AMOUNT |
|----------|-----------|---------|-------|---|-----|------------|----------|
| ORDERED | B.O./RET. | SHIPPED | | | | | |
| | | | | ***For price information*** See www.huntingtonhardware.com | | | |
| 44 | | | | *SC L9071P 06A 626 L283-711 EV29T | EA | 420.0000 | 18480.00 |
| 16 | | | | *SC L9070P 06A 626 EV29T | EA | 335.0000 | 5360.00 |
| 17 | | | | *SC L9080P LLL 06A 626 L283-150 EV29T | EA | 341.0000 | 5797.00 |
| 8 | | | | *SC L9080P 06A 626 EV29T | EA | 335.0000 | 2680.00 |
| 2 | | | | *SC L9485P 06A 626 L583-363 L283-722 EV29T | EA | 425.0000 | 850.00 |
| 8 | | | | *SC L9456P 06A 626 L583-363 EV29T | EA | 355.0000 | 2840.00 |
| 3 | | | | SCL9040-06A-626 06A PRIV SAT/CHROM *X L583-363 | EA | 296.0000 | 888.00 |

TERMS & CONDITIONS
 This quotation is valid for 60 days.
 Quoted prices are for quantities specified.
 We reserve the right to correct clerical errors at any time.
 All prices are exclusive of shipping charges & state and local taxes.

SUB TOTAL CONTINUED
 MISC. CHARGE.
 TELE. CHARGE
 FREIGHT TOTAL
 FED./OTHER TAX
 STATE TAX
 PAYMENT REC'D.

| | | | |
|--|------|-------------|------------------|
| Upon acceptance of this quote, please sign and return one copy | Date | Accepted By | Purchase Order # |
|--|------|-------------|------------------|



HUNTINGTON HARDWARE CO., INC.

340 West Holt Avenue
 Pomona, Ca. 91768-3105
 Phone (909) 629-5301 Fax (909) 620-8962

QUOTATION

QUOTATION NUMBER

QUOTATION NUMBER

STAHAR

1071504-0000-01

1071504-0000-01

BILL TO: STAR HARDWARE, INC.
 8727 LANYARD COURT
 R. CUCAMONGA CA 91730

SHIP TO: STAR HARDWARE, INC.
 8727 LANYARD COURT
 R. CUCAMONGA CA 91730

481-7331

CUSTOMER P.O.NO. LEMONWOOD

CUSTOMER P.O.NO. LEMONWOOD

QUOTATIONQUOTATION***QUOTATION***QUOTATION***QUOTATION***

| QUOTATION NUMBER | SLSMN | ORDER DATE | TAKER | CUSTOMER P.O. NUMBER | DATE |
|------------------|-------|------------|-------|----------------------|------|
| 1071504-0000-01 | 146 | 10/24/16 | 150 | LEMONWOOD | |

INSTRUCTIONS

WILL CALL

| FRT. | PAGE NO. |
|------|----------|
| B | 2 |

| QUANTITY | | | DISP. | ITEM CODE AND DESCRIPTION | U/M | UNIT PRICE | AMOUNT |
|----------|-----------|---------|-------|---|-----|------------|----------|
| ORDERED | B.O./RET. | SHIPPED | | | | | |
| 8 | | | | SCL9010-06A-626 06A PASS SAT/CHROM L583-363 | EA | 243.0000 | 1944.00 |
| 15 | | | | *VD PAAXCDSI98NL-OP 626 3' | EA | 827.0000 | 12405.00 |
| 8 | | | | *VD PAAXCDSI98EO 626 3' | EA | 771.0000 | 6168.00 |
| 6 | | | | *VD PAAX98L-F-2SI 626 3' | EA | 1199.0000 | 7194.00 |
| 5 | | | | *VD KR4954 MT54 7' | EA | 544.0000 | 2720.00 |
| 8 | | | | *SC 20-022 626 EV29T | EA | 35.0000 | 280.00 |
| 10 | | | | *SC 20-002 626 EV29T | EA | 35.0000 | 350.00 |
| 1 | | | | *VRT-24 X CTC US 26D | EA | 150.0000 | 150.00 |

TERMS & CONDITIONS
 This quotation is valid for 60 days.
 Quoted prices are for quantities specified.
 We reserve the right to correct clerical errors at any time.
 All prices are exclusive of shipping charges & state and local taxes.

| | |
|----------------|-----------|
| SUB TOTAL | 68,106.00 |
| MISC. CHARGE. | |
| TELE. CHARGE | |
| FREIGHT TOTAL | |
| FED./OTHER TAX | 0.00 |
| STATE TAX | 0.00 |
| PAYMENT REC'D. | 0.00 |

| Upon acceptance of this quote, please sign and return one copy | Date | Accepted By | Purchase Order # |
|--|------|-------------|------------------|
| | | | |

AL AMOUNT DUE
 68,106.00

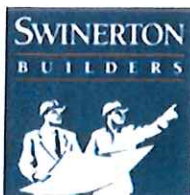

October 26, 2016

Oxnard School District
 1051 South A Street
 Oxnard, CA, 93030

Attn: Ms. Marlene Hickle/ Mr. Greg Grant- CFW

Subject: Swinerton Builders Job 16055106 - Lemonwood K-8 School LLB
 PCI No. 0075

Dear Ms. Hickle and Mr. Grant,

We request a Change Order to our contract for the following:

During submittal review EEOR made changes to the lighting fixture package that was provided and approved per VE exercise

| Phase | Category | Description | Subcontractor | Quote |
|--------|----------|--|------------------------|------------------|
| 260010 | 71140 | During submittal review EEOR made changes to the lighting fixture package that was provided and approved per VE exercise | TAFT ELECTRIC COMPANY | 18,738.00 |
| | | | Subtotal | 18,738.00 |
| 007480 | 71160 | Subguard | 1.15% | 215.49 |
| 007410 | 71160 | Builders Risk | 0.6% | 113.72 |
| 007420 | 71160 | General Insurance | 1.15% | 217.97 |
| 007510 | 71160 | P&P Bond | 1% | 187.38 |
| 991000 | 79999 | Change Order Fee | 15% | 2,892.78 |
| | | | Markup Subtotal | 3,627.34 |
| | | | PCI Total | 22,365.34 |

cf.

TOTAL AMOUNT OF THIS CHANGE ORDER REQUEST: **22,365.34.**

Please NOTE:

- » The incorporation of this revision in to the contractual scope of work may have an impact on our schedule, which is yet to be finalized. Once determined, the job schedule will be adjusted accordingly to show the effect of this revision on the final project completion date.
- » The terms (cost and schedule impact) of this change order request are subject to review and a requote if not accepted within days of its issuance.
- » This request does not include additional cost or delay due to late approval.

X We **HAVE NOT** proceeded with this revised work per your instructions. Please issue a change order.



Upon acceptance of this change order request, a formal change order will be issued. Acceptance also acknowledges that Swinerton Builders is directed to proceed with the above change in scope.

If you have any questions or comments pertaining to this matter, please contact the undersigned.

Sincerely,
Swinerton Builders

A handwritten signature in blue ink, appearing to read "Bill Gray", is written over the printed name.

Bill Gray
PM

Date: _____

10/26/2016

Quotation accepted by:
Oxnard School District

By: _____

Date: _____

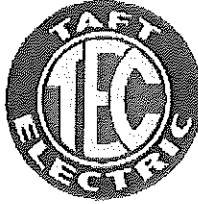

Taft Electric Company

1694 Eastman Avenue
Ventura, CA 93003
(805)642-0121
Contractor License # 772245

Change Order Request

Detailed, Grouped by Each Number

2241 Lemonwood
2200 Carnegie Court
Oxnard, CA 93033

Project # 2241
Tel: Fax:

TAFT ELECTRIC COMPANY

Change Order Request: 020 Date: 10/24/2016

| | | | |
|------------|--|--------------|--|
| To: | Bill Gray Swinerton Builders 865 S. Figueroa Street Los Angeles, CA 90017 | From: | Matt Gobuly TAFT ELECTRIC COMPANY P.O. Box 3416 Ventura, CA 93006 |
|------------|--|--------------|--|

| | | |
|--|-----------------|---------------|
| Description | Category | Status |
| Changes to Value Engineered Lighting Package | | OPEN |

| | | | |
|------------------|--------------------|-----------------|----------------|
| Reference | Required By | Days Req | Amt Req |
| | 10/31/2016 | 0 | 18,738 |

Notes

We are submitting the above cost to provide light fixtures based on comments from our TEC 005A Lighting Fixtures Submittal. Comments from the engineer have requested Taft to provide the following:

- Type 1 - Provide 3500k (per manufacturers website it is available.) Provide dimming. Use 36,000LM.
- Type 4 & 5, 5E - Provide 1'x4' LED fixture.

A revised light fixture submittal package is included with this COR.

This quote is valid for 30 calendar days from the above date. we reserve our right to re-quote this proposal should the approval take longer than 30 days.

Attached is the back up for your review. Please call should you have any questions.

Matt Gobuly
Project Manager
(805)654-7994

| PCO No | Date | Reference | Amt Prop | Days Req | Category | Reason |
|--------------------|------|-----------|--------------|----------|----------|--------|
| Description | | | Notes | | | |

Approved By:

Signature _____

Name _____ Date _____

This review is only for general conformance with the design concept of the project and general compliance with the information included in the Contract Documents. Any action shown is subject to the requirements of the drawings and specifications. No action shown here shall in anyway relieve the contractor of the responsibility of providing complete and operating systems as shown on the Contract Documents. Contractor is responsible for correlating and confirming dimensions at the job site; choice of fabrication processes and techniques of construction; coordination of his work with that of other trades; and performing the work in a safe and satisfactory manner.

| ITEM(S) SUBMITTED | REVIEW COMMENTS AND INSTRUCTIONS | COMMENTS |
|-------------------|--|---|
| Lighting Fixtures | <input type="checkbox"/> No Exception Taken <input checked="" type="checkbox"/> Make Corrections Noted <input type="checkbox"/> Rejected <input type="checkbox"/> Revise and Resubmit | <ol style="list-style-type: none"> 1. Type 1 – Provide 3500k (per manufacturers website it is available.) Provide dimming. Use 36,000LM. 2. Type 4 & 5, 5E – Provide 1'x4' LED fixture. 3. Types 2, 3, 6, 9, 9A, 11, 12, 13, X – No exception taken. |

Reviewed By: Bill Voller

Date: 09/21/2016

P:\2013\2013-0451 OSD Lemonwood K-8\Admin\Electrical\Submittals\26 0000-005 - Lighting Fixtures_SBR\26 0000-005 - Lighting Fixtures_SBR.docx



See revised Submittals below



October 17, 2016

Taft Electric
1694 Eastman Ave
Ventura CA 93003
Attn: Matt

Matt,

The following is in response to the general comments from Bill Voler of TK1SC, regarding the lighting fixtures for Lemonwood School.

- Type 1 We are resubmitting on the Acuity # **JHBL 35000LM GL WD 277 GZ10 30K 80CRI MSE62L3VWL DWH** high lumen LED high bay fixture as requested.
- Changing from 18,000 lumens to 36,000 lumens. Using 3500 kelvin LED as specified. There will be a cost impact for this change.
- Please note that the fixture will require a tandem mounting bar bracket (**HKMI**) and installation instructions are included in this package for clarification.
- Type 1EM Resubmitting on the Acuity # **JHBL 35000LM GL WD 277 GZ10 30K 80CRI BSL722C MSE62L3VWL DWH**
- Same comments as above, except the inclusion of a Bodine emergency battery pack producing 2835 lumens. There is a cost impact for the higher lumen package.
- Type 4 Resubmitting on the Acuity # **GTL 4 40L A19 EZ1 LP835**, LED troffer, featuring .156" thick acrylic lens, 0-10V dimming. There is a cost impact over the fluorescent fixture originally specified.
- Type 4EM Resubmitting on the Acuity # **GTL 4 40L A19 EZ1 EL14L LP835**. The features are same as above, except the inclusion of an emergency battery pack (**EL14L**). There will be a cost impact.
- Type 5 Resubmitting on the Kenall # **MLHA8 48 F MW PP 45L35K DCC DV**. This is an architectural surface mounted vandal resistant LED fixture with 0-10V dimming. There will be a cost impact over the originally specified fluorescent fixture.

Please review the submittals and the revised pricing and feel free to call with any questions or clarifications that you require.

Regards,

J.R. Dominguez

JOB Lemonwood School (per September 16, submittal comments COR 020)

CONTR. TAFT

NAME MATT G

DIST. CED/VENTURA

DATE 10/20/2016

| * TYPE | ORD. | REV | VOLTS | MTG. | FINISH | OPTIONS/COMMENTS | ADD | DEL | CHG | COST | TOTAL |
|--------|------|-----|-------|------|--------|------------------|-----|-----|------|------------|--------------|
| 1 | 10 | 0 | 120 | PEND | DWH | 18000LM | 0 | 10 | -10 | \$574.00 | -\$5,740.00 |
| 1EM | 10 | 0 | 120 | PEND | DWH | 18000LM with EM | 0 | 10 | -10 | \$935.00 | -\$9,350.00 |
| 1 | 0 | 10 | 120 | PEND | DWH | 36000LM | 10 | 0 | 10 | \$832.00 | \$8,320.00 |
| 1EM | 0 | 10 | 120 | PEND | DWH | 36000LM with EM | 10 | 0 | 10 | \$1,158.00 | \$11,580.00 |
| 4 | 34 | 0 | MVOLT | REC | STD | FLUORESCENT | 0 | 34 | -34 | \$50.00 | -\$1,700.00 |
| 4EM | 10 | 0 | MVOLT | REC | STD | FLUORESCENT w/EM | 0 | 10 | -10 | \$153.00 | -\$1,530.00 |
| 4 | 0 | 34 | MVOLT | REC | STD | LED | 34 | 0 | 34 | \$130.00 | \$4,420.00 |
| 4EM | 0 | 10 | MVOLT | REC | STD | LED w/EM | 10 | 0 | 10 | \$313.00 | \$3,130.00 |
| 5 | 74 | 0 | DV | SURF | MW | FLUORESCENT | 0 | 74 | -74 | \$225.00 | -\$16,650.00 |
| 5EM | 17 | 0 | DV | SURF | MW | FLUORESCENT w/EM | 0 | 17 | -17 | \$370.00 | -\$6,290.00 |
| 5LP | 182 | 0 | N/A | N/A | N/A | LAMPS ONLY | 0 | 182 | -182 | \$2.05 | -\$373.10 |
| 5 | 0 | 74 | DV | SURF | MW | LED | 74 | 0 | 74 | \$278.00 | \$20,572.00 |
| 5EM | 0 | 17 | DV | SURF | MW | LED w/EM | 17 | 0 | 17 | \$472.00 | \$8,024.00 |
| | | | | | | | 0 | 0 | 0 | \$0.00 | \$0.00 |
| | | | | | | | 0 | 0 | 0 | \$0.00 | \$0.00 |
| | | | | | | | 0 | 0 | 0 | \$0.00 | \$0.00 |
| | | | | | | | 0 | 0 | 0 | \$0.00 | \$0.00 |
| | | | | | | | 0 | 0 | 0 | \$0.00 | \$0.00 |
| | | | | | | | 0 | 0 | 0 | \$0.00 | \$0.00 |
| | | | | | | | 0 | 0 | 0 | \$0.00 | \$0.00 |
| | | | | | | | 0 | 0 | 0 | \$0.00 | \$0.00 |
| | | | | | | | 0 | 0 | 0 | \$0.00 | \$0.00 |
| | | | | | | | 0 | 0 | 0 | \$0.00 | \$0.00 |
| | | | | | | | 0 | 0 | 0 | \$0.00 | \$0.00 |

Total Adds 155 \$56,046.00
 Total Deletes 337 (\$41,633.10)
 New Lot Total \$14,412.90

PH: (805)642-7714

MAR VISTA SALES

1845 Knoll Drive
Ventura, Ca. 93003

FAX: (805)642-0953

Manufacturer's Representative
For
Lighting & Controls

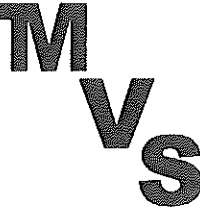

TRANSMITTAL

TO: **CED VENTURA**
1807 Palma Drive
Ventura, CA 93003
CONT: Taft Electric

DATE: 08/18/16
ATTN: Karrie Theis
JOB NAME: : Lemonwood K-8 Reconstruction, Oxnard
AIA/EE:

ENCLOSED FIND **1** COPIES OF SUBMITTALS RESUBMITTALS

FOR: APPROVAL AS CORRECTED FOR YOUR USE FOR RECORD

PRIOR TO RELEASE OF FIXTURES WE WILL REQUIRE THE FOLLOWING

- CONFIRMING P.O. CONFIRMATION OF ACCOUNTS WRITTEN RELEASE
- ONE COPY OF APPROVED SUBMITTALS CONFIRMATION OF VOLTAGES
- FINISHES OF THE FOLLOWING TYPE

REMARKS:

PLEASE NOTE

THESE SUBMITTALS ARE OUR INTERPRETATION OF THE SPECIFICATIONS AND PLANS AND REPRESENTS WHAT WE INTEND ON SUPPLYING FOR THE ABOVE PROJECT.

VOLTAGES WILL BE PROVIDED AS MARKED, IF NO VOLTAGE IS MARKED 120 VOLTS WILL BE PROVIDED.

BALLAST WILL BE AS MARKED. IF A SPECIAL TYPE OR MANUFACTURER IS REQUIRED AND NOT SHOWN ON SUBMITTALS PLEASE CONTACT US.

STANDARD FINISHES WILL BE PROVIDED, UNLESS OTHERWISE MARKED ON SUBMITTAL.

ALL FIXTURES AR PROVIDED WITH STANDARD MOUNTING UNLESS OTHERWISE MARKED. OPTIONAL MOUNTING ACCESSORIES ARE NOT INCLUDED , UNLESS OTHERWISE MARKED.

ONE SET OF APPROVED DRAWINGS OR A SIGNED WAIVER OF APPROVAL WILL BE REQUIRED BEFORE RELEASE.

HARD COPY ELECTRONIC FIELD FILE



LEMONWOOD K-8 RECONSTRUCTION

TABLE OF CONTENTS

| TYPE | MANUFACTUER | PART NUMBER |
|-------|-------------|---|
| 1 | LITHONIA | JHBL 35000LM GL WD 120 GZ10 35K 80CRI MSE62L3VWL DWH |
| 1EM | LITHONIA | JHBL 35000LM GL WD 120 GZ10 35K 80CRI BSL722C MSE6L3VWL DWH |
| 1/1EM | LITHONIA | HKMI |
| 4 | LITHONIA | GTL 4 40L A19 EZ1 LP835 |
| 4EM | LITHONIA | GTL 4 40L A19 EZ1 EL14L LP835 |
| 5 | KENALL | MLHA8 48 F MW PP 45L35 DCC DV |
| 5EM | KENALL | MLHA8 48 F MW PP 45L35 DCC DV LEL |

FEATURES & SPECIFICATIONS

INTENDED USE — The JHBL is constructed to withstand moisture, dust, and chemical contact. Common applications for JHBL include demanding environments such as manufacturing, foundries, natatoriums, gymnasiums, automotive manufacturing, packaging, and cold storage. Ideal one-for-one replacement of conventional HID and fluorescent high bay systems.

CONSTRUCTION — Electrical housing is off-set from the optical assembly for maximum heat dissipation. Rugged die-cast aluminum housing and corrosion resistance. Housing utilizes die cut rubber gasketing to seal the optical and electrical compartments from dust and moisture. Wire guard attachment points are precast in optical housing. Housing and optics maintain IP65 rating with all internal components including optional integrated sensor.

OPTICS — One piece precision molded .375" thick borosilicate glass that is silicone rubber gasketed. Optional non-silicone gasket available and recommended for automotive applications.

ELECTRICAL — Non-class 2 drivers standard for maximum life at high temperatures. Less than 10% THD and PF >90. 3kA/6kV level of surge protection is standard. Multiple voltages available including HVOLT and 250VDC. Lumen maintenance is 90% at 60,000 hours. L70 greater than 100,000 hours. 0-10V dimming standard for a dimming range of 100% to 10% - dimming source current is 150 microA

INSTALLATION — 3/4 inch NPS threaded hub standard that is suitable for pendant, hook or loop mounting with appropriate mounting accessories. See accessories for available options.

LISTINGS — CSA certified to US and Canadian safety standards. Wet location listed. IP65 rated. Suitable for use in ambient temperatures from -40°F (-40°C) to 131°F (55°C). High ambient (HA option) up to 65°C available for MVOLT, HVOLT and 250VDC drivers. Patent pending. Covered ceiling not required to maintain wet location listing or IP ratings.

DesignLights Consortium® (DLC) qualified product. Not all versions of this product may be DLC qualified. Please check the DLC Qualified Products List at www.designlights.org to confirm which versions are qualified.

WARRANTY — 5-year limited warranty. Complete warranty terms located at www.aquitybrands.com/CustomerResources/Terms_and_conditions.aspx

Note: Actual performance may differ as a result of end-user environment and application.

All values are design or typical values, measured under laboratory conditions at 25 °C.

Specifications subject to change without notice.

LED IP Rated High Bay

JHBL

12000LM, 18000LM, 24000LM, 30000LM,
35000LM, 40000LM, 45000LM

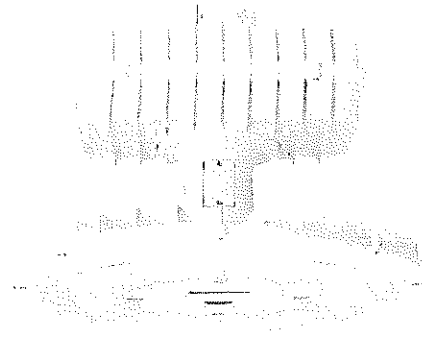

DIMENSIONS

All dimensions are in inches (centimeters) unless otherwise indicated. Dimensions may vary with options or accessories.

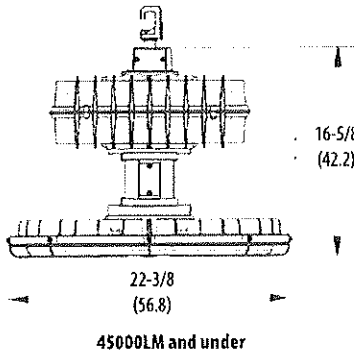

Typical weight:

A cartoned luminaire weighs 50 lbs.;
unboxed it weighs 43 lbs.

Shown with HKM(G) mounting accessory.
See accessory options on page 2.

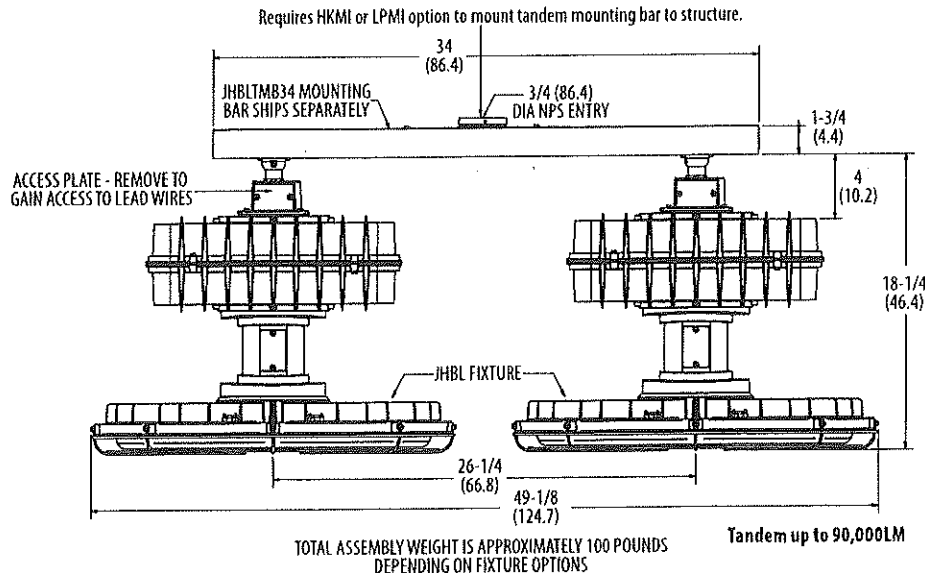
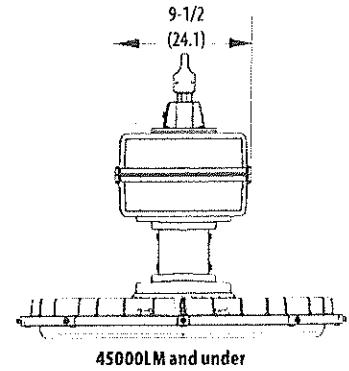

JHBL LED IP Rated High Bay

ORDERING INFORMATION

Lead times will vary depending on options selected. Consult with your sales representative.

Example: JHBL 18000LM GL WD MVOLT GZ10 50K 70CRI CS89 DWHXD

| JHBL | 35000LM | GL | WD | 120 | GZ10 | 35K | 80 CRI |
|--------------------------------------|--------------------------------------|-------------------------|--------------|----------------|--------------------|-------------------|-----------------------|
| Series | Lumens-(single unit) | Lens | Distribution | Voltage | Driver | Color temperature | Color rendering index |
| JHBL | 12000LM 12,000 lumens | GL Glass | WD Wide | MVOLT 120-277V | GZ10 0-10V dimming | 35K 3500 K | 70CRI 70 CRI |
| | 18000LM 18,000 lumens | ACL Clear Acrylic | ND Narrow | HVOLT 347-480V | | 40K 4000 K | 80CRI 80 CRI |
| | 24000LM 24,000 lumens | PCL Clear Polycarbonate | | 120 120V | | 50K 5000 K | 90CRI 90 CRI |
| | 30000LM 30,000 lumens ¹ | | 277 277V | | | | |
| | 35000LM 35,000 lumens ¹ | | 347 347V | | | | |
| | 40000LM 40,000 lumens ^{1,2} | | 480 480V | | | | |
| 45000LM 45,000 lumens ^{1,2} | 250DC 250VDC ³ | | | | | | |

| MSW62L3VWL | | | | Color ¹⁴ |
|-------------------|--|--|------------------------|----------------------------------|
| Options | | | Controls ¹² | Super durable finishes |
| SF | Single fusing ^{4,5} | | MSE6NWL | DWHXD White |
| DF | Double fusing ^{4,6} | | MSE62L3VWL | DNAXD Natural aluminum |
| BSL722 | Bodine® emergency LED battery pack for 0°C and up ^{4,7,8} | | MSE6NWL DSCNWL | DWHGXD Textured white |
| BSL722C | Bodine® emergency LED battery pack for 20°C and up ^{4,7,8} | | MSE10NWL | DNATXD Textured natural aluminum |
| WGX | Standard wire guard, installed | | MSE102L3VWL | |
| NSG | Non-silicone gasket | | MSE10NWL DSCNWL | |
| HA | Up to 65°C ambient operation ⁹ | | MSE6XAWL | |
| Cord sets: | | | MSE10XAWL | |
| CS88 | 6' Brad Harrison 16/3 cord and straight blade plug set, wet location ⁴ | | MSE10XAWL924 | |
| CS88L12 | 12' Brad Harrison 16/3 cord and straight blade plug set, wet location ⁴ | | MSE10XAWL | |
| CS89 | 6' white cord, 16/3, no plug, wet location ¹⁰ | | MSE10XAWL924 | |
| CS89L12 | 12' white cord, 16/3, no plug, wet location ¹⁰ | | XAD | |
| CS6G16STOW5D | 6' white cord, 16/5, no plug, wet location, includes low voltage dimming wires | | NPP16D | |
| HC3PC3RWT | Wet location, hook, 3' cord, plug and receptacle ^{4,11} | | NPP16DER | |

| Options (Fixtures utilizing the below options will bear a damp location label.) | | | |
|---|---|------|--|
| DL | Damp location ¹⁵ | LCPP | Loop, cord, non-NEMA 14A twist-lock plug ^{4,16} |
| HCX | Hook, cord, no plug ^{16,17} | HOCS | Hook, 5' RELOC® OCS ^{4,17} |
| HCXP | Hook, cord, 15A NEMA twist-lock plug ^{4,16,17} | LOCS | Loop, 5' RELOC® OCS ^{4,17} |
| LCXP | Loop, cord, 15A NEMA twist-lock plug ^{4,16,17} | OCS | 5' RELOC® OCS ⁴ |

| Accessories: Order as separate catalog number. | | | |
|--|--|---------------|---|
| Wet location | Damp location | Damp location | Damp location |
| WGJHBL | Wire guard | HKM | Aluminum fixture hook male ¹⁷ |
| HKMG | Grommated aluminum fixture hook male ¹⁷ | LPM | Aluminum fixture loop male ¹⁷ |
| LPMG | Grommated aluminum fixture loop male ¹⁷ | HKMI | Iron fixture hook male |
| JHBLSCK120 | 10' safety cable | LPMI | Iron fixture loop male |
| JHBLSCK84 | 7' safety cable | | |
| | | TPH | Through-wire power hook ^{17,19} |
| | | PPH | Pendant power hook ^{17,19} |
| | | JHBLTMB34 DWH | 34" tandem mounting bar (standard white) ^{14,20} |

See foot notes for above on page 3.



An AcuityBrands Company

JHBL

JHBL LED IP Rated High Bay

Notes

- Tandem available in 30000LM, 35000LM, 40000LM, 45000LM (to order double the lumens - ex: 30000LM order as 60000LM)
- Not available with 250VDC.
- Not available with 40,000LM, 45,000LM, or control options.
- Must specify voltage.
- Available with 120, 277 or 347V.
- Available with 208, 240 or 480V.
- Not available with HA option.
- Factory installed only. Must specify voltage. Not available with 347V, 480V, MVOLT, HVOLT or HA option. For use in ambient temperatures up to 35°C. Emergency IES files available on www.lithonia.com. Four conductor cords ship when a cord is ordered with the BSL722 options.
- Not available with controls, battery packs, or XPoint. See operational data table for correct ambient temp based on fixture.
- Fixtures ship with black 4-conductor cords when BSL722 options are ordered.
- Total cord length 6' (3' on plug side and 3' on receptacle side). Other lengths available in odd increments. Ex: 5', 7', 9', etc.
- Not available with HA option. For use in ambient temperatures up to 50°C. Not field installable; must be factory installed.
- Available with 120, 277, 347, and 480. 480V utilizes a step transformer.
- Lithonia standard and architectural colors also available. Consult sales representative.
- Required for fixtures utilizing damp location options. Ex: HKM, LPM, etc.
- X denotes length of cord. Cords are available in odd increments. Ex: 3', 5', 7', etc.
- Not available with JHBLTMB34.
- Requires TPH or PPH accessory.
- Fixture must have LCPP option.
- Not recommended for wet locations. Requires (1) HKMI or (1) LPMI to mount tandem bar to structure.

OPERATIONAL DATA

| Lumen package | Ambient rating (120V - 277V) | Ambient rating (347V / 480V) | Distribution | Delivered Lumens | | | | | | | | | LPW* | Input wattage |
|---------------|--------------------------------|--------------------------------|--------------|------------------|-------|-------|-------|--------|-------|-------|-------|-------|------|---------------|
| | | | | 3500K | | | 4000K | | | 5000K | | | | |
| | | | | 70CRI | 80CRI | 90CRI | 70CRI | 80CRI | 90CRI | 70CRI | 80CRI | 90CRI | | |
| 12000LM | -40°F to 149°F (-40°C to 65°C) | -40°F to 149°F (-40°C to 65°C) | ND | 11662 | 10671 | 7500 | 12195 | 10747 | 7829 | 12271 | 10671 | 8232 | 123 | 100 |
| | | | WD | 11724 | 10728 | 7540 | 12261 | 108050 | 7871 | 12337 | 10728 | 8276 | 123 | |
| 18000LM | -40°F to 149°F (-40°C to 65°C) | -40°F to 149°F (-40°C to 65°C) | ND | 17874 | 16355 | 11495 | 18692 | 16472 | 12000 | 18808 | 16355 | 12617 | 123 | 153 |
| | | | WD | 17970 | 16443 | 11557 | 18792 | 16560 | 12064 | 18909 | 16443 | 12685 | 124 | |
| 24000LM | -40°F to 149°F (-40°C to 65°C) | -40°F to 149°F (-40°C to 65°C) | ND | 22963 | 21012 | 14768 | 24014 | 21162 | 15417 | 24164 | 21012 | 16209 | 123 | 197 |
| | | | WD | 20386 | 21125 | 14848 | 24143 | 21276 | 15500 | 24293 | 21125 | 16296 | 123 | |
| 30000LM | -40°F to 140°F (-40°C to 60°C) | -40°F to 140°F (-40°C to 60°C) | ND | 28958 | 26497 | 18624 | 30283 | 26687 | 19442 | 30472 | 26497 | 20441 | 122 | 251 |
| | | | WD | 29114 | 26640 | 18724 | 30446 | 26830 | 19546 | 30636 | 26640 | 20551 | 122 | |
| 35000LM | -40°F to 140°F (-40°C to 60°C) | -40°F to 140°F (-40°C to 60°C) | ND | 32883 | 30089 | 21148 | 34387 | 30304 | 22877 | 34602 | 30089 | 23212 | 121 | 285 |
| | | | WD | 33060 | 30251 | 21262 | 34572 | 30467 | 22195 | 34788 | 30251 | 23336 | 122 | |
| 40000LM | -40°F to 140°F (-40°C to 60°C) | -40°F to 140°F (-40°C to 60°C) | ND | 38657 | 35373 | 24862 | 40426 | 35625 | 25954 | 40679 | 35373 | 27288 | 118 | 344 |
| | | | WD | 38865 | 35563 | 24996 | 40643 | 35817 | 26093 | 40897 | 35563 | 27434 | 119 | |
| 45000LM | -40°F to 140°F (-40°C to 60°C) | -40°F to 140°F (-40°C to 60°C) | ND | 44289 | 40526 | 28484 | 46315 | 40815 | 29734 | 46605 | 39448 | 30431 | 117 | 397 |
| | | | WD | 43342 | 39660 | 27875 | 45325 | 39943 | 29099 | 45609 | 39660 | 30595 | 115 | |

CHARACTERISTICS

| Lumen package | Weight | Comparable light source |
|---------------|------------------|----------------------------------|
| 12000LM | 43 lbs (19.5 kg) | 4-lamp T8, 250W HID |
| 18000LM | 43 lbs (19.5 kg) | 4-lamp T5HO, 6-lamp T8, 320W HID |
| 24000LM | 43 lbs (19.5 kg) | 6-lamp T5HO, 8-lamp T8, 400W HID |
| 30000LM | 43 lbs (19.5 kg) | 6-lamp T5HO, 8-lamp T8, 400W HID |
| 35000LM | 43 lbs (19.5 kg) | 8-lamp T5HO, 750W HID |
| 40000LM | 43 lbs (19.5 kg) | 10-lamp T5HO, 750W HID |
| 45000LM | 43 lbs (19.5 kg) | 12-lamp T5HO, 1000W HID |

PROJECTED LUMEN MAINTENANCE

| Operating hours | 0 | 10,000 | 20,000 | 25,000 | 35,000 | 50,000 | 60,000 | 100,000 |
|--------------------------|---|--------|--------|--------|--------|--------|--------|---------|
| Lumen maintenance factor | 1 | 0.96 | 0.94 | 0.93 | 0.92 | 0.91 | 0.90 | 0.86 |

EMERGENCY LUMENS (5000K 70CRI)

| | 12000LM | 18000LM | 24000LM | 30000LM | 35000LM | 40000LM | 45000LM |
|---------------------|---------|---------|---------|---------|---------|---------|---------|
| Narrow distribution | 3101 | 2820 | 2820 | 2820 | 2820 | 2820 | 2820 |
| Wide Distribution | 3117 | 2835 | 2835 | 2835 | 2835 | 2835 | 2835 |



An Acuity Brands Company

JHBL LED IP Rated High Bay

PHOTOMETRICS

See www.lithonia.com.

SBGR – EMBEDDED Motion Sensor (see www.acuitycontrols.com for additional information)

- 360° coverage
- On/Off dim
- Photocell optional
- IP65 rated
- Photocell and 0-10VDC dimming options.
- Maximum ambient temperature 50°C

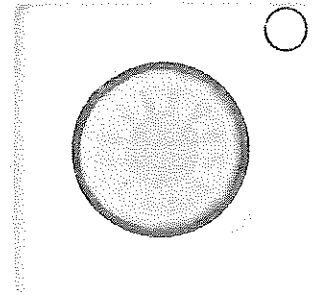

| Lithonia nomenclature | Sensor Switch* nomenclature |
|---|-----------------------------|
| For shortest lead times use one of the following SBGR configurations. | |
| MSE6NWL | SBGR 6 WH |
| MSE62L3VWL | SBGR 6 D WH 3V |
| MSE6NWL DSCNWL | SBGR 6 P WH |
| MSE10NWL | SBGR 10 WH |
| MSE102L3VWL | SBGR 10 D WH 3V |
| MSE10NWL DSCNWL | SBGR 10 P WH |

MOTION SENSOR

ORDERING INFORMATION

Lead times will vary depending on options selected. Consult with your sales representative.

Example: MSE6NWL

| Series | Lens option | Dimming | Environmental factors | Time delay |
|--|--|---|-----------------------|--|
| MSE Passive infrared embedded occupancy sensor | 6 High mount, 360° 10 Low mount, 360° | N On/off 2LXX Bi level range ¹ XA XPoint™ wireless signal to external system | WL Wet location | (blank) 10 minutes 5M 5 minutes 15M 15 minutes |

Notes

¹ XX denotes "Low" level on 0-10V output.

PHOTOCELL

ORDERING INFORMATION

Lead times will vary depending on options selected. Consult with your sales representative.

Example: DSCNWL

| Series | Dimming | Environmental factors |
|--|---|-----------------------|
| DSC Closed loop (see external and fixture light) | N On/off CXX Continuous dimming and override off ¹ XA XPoint™ wireless signal to external system | WL Wet location |

Notes

¹ Available with low mount only.



An AcuityBrands Company

JHBL

JHBL LED IP Rated High Bay

COVERAGE PATTERNS

SITE & AREA LIGHTING / HIGH MOUNT APPLICATIONS

The **SBGR 6 ODP** is intended for higher applications, between 15-30 ft, and provides a coverage area radius for walking motion of 15-20 ft.

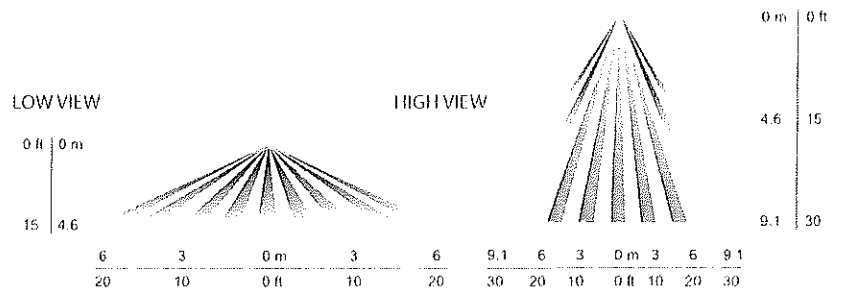

Coverage Pattern of High Mount Lens Option (SBGR 6 ODP)

FEATURES & SPECIFICATIONS

INTENDED USE — The JHBL is constructed to withstand moisture, dust, and chemical contact. Common applications for JHBL include demanding environments such as manufacturing, foundries, natatoriums, gymnasiums, automotive manufacturing, packaging, and cold storage. Ideal one-for-one replacement of conventional HID and fluorescent high bay systems.

CONSTRUCTION — Electrical housing is off-set from the optical assembly for maximum heat dissipation. Rugged die-cast aluminum housing and corrosion resistance. Housing utilizes die cut rubber gasketing to seal the optical and electrical compartments from dust and moisture. Wire guard attachment points are precast in optical housing. Housing and optics maintain IP65 rating with all internal components including optional integrated sensor.

OPTICS — One piece precision molded .375" thick borosilicate glass that is silicone rubber gasketed. Optional non-silicone gasket available and recommended for automotive applications.

ELECTRICAL — Non-class 2 drivers standard for maximum life at high temperatures. Less than 10% THD and PF >90. 3kA/6kV level of surge protection is standard. Multiple voltages available including HVOLT and 250VDC. Lumen maintenance is 90% at 60,000 hours. L70 greater than 100,000 hours. 0-10V dimming standard for a dimming range of 100% to 10% - dimming source current is 150 microA

INSTALLATION — 3/4 inch NPS threaded hub standard that is suitable for pendant, hook or loop mounting with appropriate mounting accessories. See accessories for available options.

LISTINGS — CSA certified to US and Canadian safety standards. Wet location listed. IP65 rated. Suitable for use in ambient temperatures from -40°F (-40°C) to 131°F (55°C). High ambient (H/A option) up to 65°C available for HVOLT, HVOLT and 250VDC drivers. Patent pending. Covered ceiling not required to maintain wet location listing or IP ratings.

DesignLights Consortium® (DLC) qualified product. Not all versions of this product may be DLC qualified. Please check the DLC Qualified Products List at www.designlights.org to confirm which versions are qualified.

WARRANTY — 5-year limited warranty. Complete warranty terms located at www.acuitybrands.com/CustomerResources/Terms_and_conditions.aspx

Note: Actual performance may differ as a result of end-user environment and application.

All values are design or typical values, measured under laboratory conditions at 25 °C.

Specifications subject to change without notice.

LED IP Rated High Bay

JHBL

12000LM, 18000LM, 24000LM, 30000LM,
35000LM, 40000LM, 45000LM

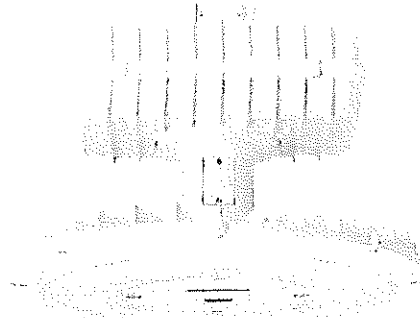

DIMENSIONS

All dimensions are in inches (centimeters) unless otherwise indicated. Dimensions may vary with options or accessories.

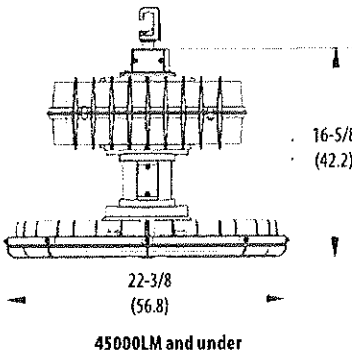

Typical weight:

A cartoned luminaire weighs 50 lbs.;
unboxed it weighs 43 lbs.

Shown with HKM(G) mounting accessory.
See accessory options on page 2.

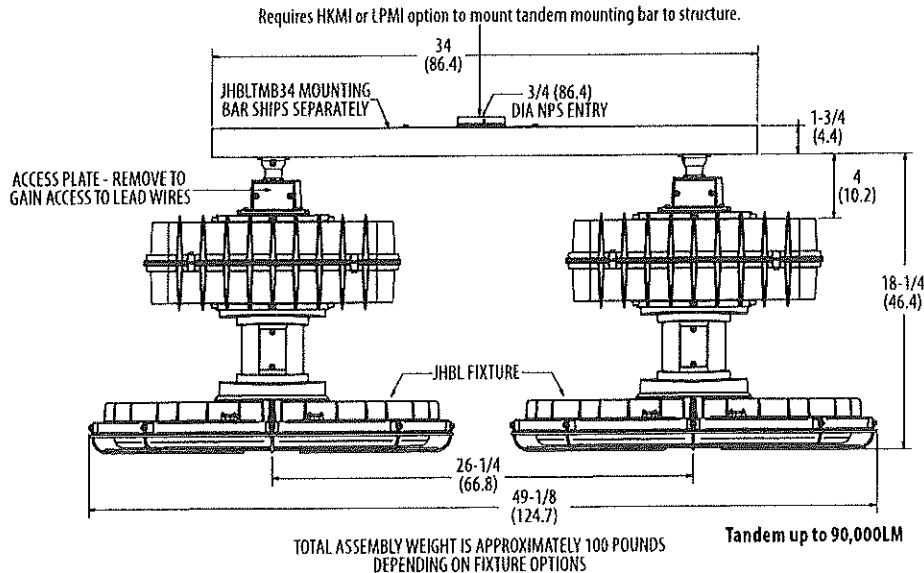
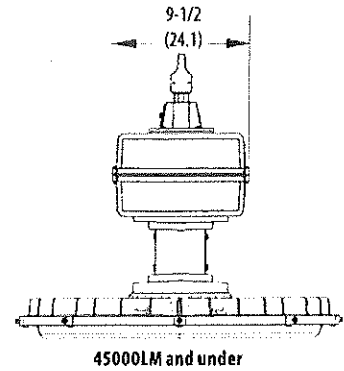

JHBL LED IP Rated High Bay

ORDERING INFORMATION

Lead times will vary depending on options selected. Consult with your sales representative. **Example:** JHBL 18000LM GL WD MVOLT GZ10 50K 70CRI CS89 DWHXD

| JHBL | 35000LM | GL | WD | 120 | GZ10 | 35K | 80CRI |
|--------|---|--|----------------------|--|--------------------|--|---|
| Series | Lumens (single unit) | Lens | Distribution | Voltage | Driver | Color temperature | Color rendering index |
| JHBL | 12000LM 12,000 lumens 18000LM 18,000 lumens 24000LM 24,000 lumens 30000LM 30,000 lumens ¹ 35000LM 35,000 lumens¹ 40000LM 40,000 lumens ^{1,2} 45000LM 45,000 lumens ^{1,2} | GL Glass ACL Clear Acrylic PCL Clear Polycarbonate | WD Wide ND Narrow | MVOLT 120-277V HVOLT 347-480V 120 120V 277 277V 347 347V 480 480V 250DC 250VDC ³ | GZ10 0-10V dimming | 35K 3500 K 40K 4000 K 50K 5000 K | 70CRI 70 CRI 80CRI 80 CRI 90CRI 90 CRI |

| BSL722C MSE62L3VWL | | | | BWHXD |
|--------------------|--|-------------------------|---|----------------------------------|
| Options | | | | Color ¹⁴ |
| SF | Single fusing ^{4,5} | Controls: ¹² | | Super durable finishes |
| DF | Double fusing ^{4,6} | MSE6NWL | Embedded high mount 360° motion sensor, wet location, On/Off operation ^{4,7} | DWHXD White |
| BSL722 | Bodine® emergency LED battery pack for 0°C and up ^{4,7,8} | MSE62L3VWL | Embedded high mount 360° motion sensor, wet location, High/Low operation (2-level) ^{4,7} | DNAXD Natural aluminum |
| BSL722C | Bodine® emergency LED battery pack for 20°C and up ^{4,7,8} | MSE6NWL DSCNWL | Embedded high mount 360° motion sensor, wet location, On/Off operation from motion sensing, Override Off due to daylight ^{4,7} | DWHGXD Textured white |
| WGX | Standard wire guard, installed | MSE10NWL | Embedded low mount 360° motion sensor, wet location, On/Off operation ^{4,7} | DNATXD Textured natural aluminum |
| NSG | Non-silicone gasket | MSE102L3VWL | Embedded low mount 360° motion sensor, wet location, High/Low operation (2-level) ^{4,7} | |
| HA | Up to 65°C ambient operation ⁹ | MSE10NWL DSCNWL | Embedded low mount 360° motion sensor, wet location, On/Off operation from motion sensing, Override Off due to daylight ^{4,7} | |
| <u>Cord sets:</u> | | MSE6XAWL | XPoint™ wireless high mount 360° motion sensor embedded, on/off, wet location ^{4,7,13} | |
| CS88 | 6' Brad Harrison 16/3 cord and straight blade plug set, wet location ⁴ | MSE6XAWL924 | XPoint™ wireless high mount 360° motion sensor with emergency relay embedded, on/off, wet location | |
| CS88L12 | 12' Brad Harrison 16/3 cord and straight blade plug set, wet location ⁴ | MSE10XAWL | XPoint™ wireless low mount 360° motion sensor embedded, on/off, wet location ^{4,7,13} | |
| CS89 | 6' white cord, 16/3, no plug, wet location ¹⁰ | MSE10XAWL924 | XPoint™ wireless low mount 360° motion sensor with emergency relay embedded, on/off, wet location | |
| CS89L12 | 12' white cord, 16/3, no plug, wet location ¹⁰ | XAD | XPoint™ wireless 0-10V relay ^{4,13} | |
| CS6616STOW5D | 6' white cord, 16/5, no plug, wet location, includes low voltage dimming wires | NPP16D | nLight® switching/dimming module | |
| HC3PC3RWT | Wet location, hook, 3' cord, plug and receptacle ^{4,11} | NPP16DER | nLight® switching/dimming module with emergency relay ⁵ | |

Options (Fixtures utilizing the below options will bear a damp location label.)

| | | | |
|------|---|------|--|
| DL | Damp location ¹⁵ | LCPP | Loop, cord, non-NEMA 14A twist-lock plug ^{4,16} |
| HCX | Hook, cord, no plug ^{16,17} | HOCS | Hook, 5' RELOC® OCS ^{4,17} |
| HCXP | Hook, cord, 15A NEMA twist-lock plug ^{4,16,17} | LOCS | Loop, 5' RELOC® OCS ^{4,17} |
| LCXP | Loop, cord, 15A NEMA twist-lock plug ^{4,16,17} | OCS | 5' RELOC® OCS ⁴ |

Accessories: Order as separate catalog number.

| Wet location | Damp location | Damp location |
|--------------|---------------|---------------|
| WGJHBL | HKM | TPH |
| HKMG | LPM | PPH |
| LPMG | HKMI | JHBLTB34 DWH |
| JHBLSC120 | LPMI | |
| JHBLSC84 | | |

Through-wire power hook^{17,19}
Pendant power hook^{17,19}
34" tandem mounting bar (standard white)^{14,20}

See foot notes for above on page 3.



An Acuity Brands Company

JHBL LED IP Rated High Bay

Notes

- 1 Tandem available in 3000LM, 3500LM, 4000LM, 4500LM (to order double the lumens - ex: 3000LM order as 6000LM)
- 2 Not available with 250VDC.
- 3 Not available with 40,000LM, 45,000LM, or control options.
- 4 Must specify voltage.
- 5 Available with 120, 277 or 347V.
- 6 Available with 208, 240 or 480V.
- 7 Not available with HA option.
- 8 Factory installed only. Must specify voltage. Not available with 347V, 480V, MVOLT, HVOLT or HA option. For use in ambient temperatures up to 35°C. Emergency IES files available on www.lithonia.com. Four conductor cords ship when a cord is ordered with the BSL722 options.
- 9 Not available with controls, battery packs, or XPoint. See operational data table for correct ambient temp based on fixture.

- 10 Fixtures ship with black 4-conductor cords when BSL722 options are ordered.
- 11 Total cord length 6' (3' on plug side and 3' on receptacle side). Other lengths available in odd increments. Ex: 5', 7', 9', etc.
- 12 Not available with HA option. For use in ambient temperatures up to 50°C. Not field installable; must be factory installed.
- 13 Available with 120, 277, 347, and 480. 480V utilizes a step transformer.
- 14 Lithonia standard and architectural colors also available. Consult sales representative.
- 15 Required for fixtures utilizing damp location options. Ex: HKM, LPM, etc.
- 16 X denotes length of cord. Cords are available in odd increments. Ex: 3', 5', 7', etc.
- 17 Not available with JHBLTB34.
- 18 Requires TPH or PPH accessory.
- 19 Fixture must have LCPP option.
- 20 Not recommended for wet locations. Requires (1) HKMI or (1) LPMI to mount tandem bar to structure.

OPERATIONAL DATA

| Lumen package | Ambient rating (120V - 277V) | Ambient rating (347V / 480V) | Distribution | Delivered Lumens | | | | | | | | | LPW* | Input wattage |
|---------------|--------------------------------|--------------------------------|--------------|------------------|-------|-------|-------|--------|-------|-------|-------|-------|------|---------------|
| | | | | 3500K | | | 4000K | | | 5000K | | | | |
| | | | | 70CRI | 80CRI | 90CRI | 70CRI | 80CRI | 90CRI | 70CRI | 80CRI | 90CRI | | |
| 12000LM | -40°F to 149°F (-40°C to 65°C) | -40°F to 149°F (-40°C to 65°C) | ND | 11662 | 10671 | 7500 | 12195 | 10747 | 7829 | 12271 | 10671 | 8232 | 123 | 100 |
| | | | WD | 11724 | 10728 | 7540 | 12261 | 108050 | 7871 | 12337 | 10728 | 8276 | 123 | |
| 18000LM | -40°F to 149°F (-40°C to 65°C) | -40°F to 149°F (-40°C to 65°C) | ND | 17874 | 16355 | 11495 | 18692 | 16472 | 12000 | 18808 | 16355 | 12617 | 123 | 153 |
| | | | WD | 17970 | 16443 | 11557 | 18792 | 16560 | 12064 | 18909 | 16443 | 12685 | 124 | |
| 24000LM | -40°F to 149°F (-40°C to 65°C) | -40°F to 149°F (-40°C to 65°C) | ND | 22963 | 21012 | 14768 | 24014 | 21162 | 15417 | 24164 | 21012 | 16209 | 123 | 197 |
| | | | WD | 20386 | 21125 | 14848 | 24143 | 21276 | 15500 | 24293 | 21125 | 16296 | 123 | |
| 30000LM | -40°F to 140°F (-40°C to 60°C) | -40°F to 140°F (-40°C to 60°C) | ND | 28958 | 26497 | 18624 | 30283 | 26687 | 19442 | 30472 | 26497 | 20441 | 122 | 251 |
| | | | WD | 29114 | 26640 | 18724 | 30446 | 26830 | 19546 | 30636 | 26640 | 20551 | 122 | |
| 35000LM | -40°F to 140°F (-40°C to 60°C) | -40°F to 140°F (-40°C to 60°C) | ND | 32883 | 30089 | 21148 | 34387 | 30304 | 22077 | 34602 | 30089 | 23212 | 121 | 285 |
| | | | WD | 33060 | 30251 | 21262 | 34572 | 30467 | 22195 | 34788 | 30251 | 23336 | 122 | |
| 40000LM | -40°F to 140°F (-40°C to 60°C) | -40°F to 140°F (-40°C to 60°C) | ND | 38657 | 35373 | 24862 | 40426 | 35625 | 25954 | 40679 | 35373 | 27288 | 118 | 344 |
| | | | WD | 38865 | 35563 | 24996 | 40643 | 35817 | 26093 | 40897 | 35563 | 27434 | 119 | |
| 45000LM | -40°F to 140°F (-40°C to 60°C) | -40°F to 140°F (-40°C to 60°C) | ND | 44289 | 40526 | 28484 | 46315 | 40815 | 29734 | 46605 | 39448 | 30431 | 117 | 397 |
| | | | WD | 43342 | 39660 | 27875 | 45325 | 39943 | 29099 | 45609 | 39660 | 30595 | 115 | |

CHARACTERISTICS

| Lumen package | Weight | Comparable light source |
|---------------|------------------|----------------------------------|
| 12000LM | 43 lbs (19.5 kg) | 4-lamp T8, 250W HID |
| 18000LM | 43 lbs (19.5 kg) | 4-lamp T5HO, 6-lamp T8, 320W HID |
| 24000LM | 43 lbs (19.5 kg) | 6-lamp T5HO, 8-lamp T8, 400W HID |
| 30000LM | 43 lbs (19.5 kg) | 6-lamp T5HO, 8-lamp T8, 400W HID |
| 35000LM | 43 lbs (19.5 kg) | 8-lamp T5HO, 750W HID |
| 40000LM | 43 lbs (19.5 kg) | 10-lamp T5HO, 750W HID |
| 45000LM | 43 lbs (19.5 kg) | 12-lamp T5HO, 1000W HID |

PROJECTED LUMEN MAINTENANCE

| Operating hours | 0 | 10,000 | 20,000 | 25,000 | 35,000 | 50,000 | 60,000 | 100,000 |
|--------------------------|---|--------|--------|--------|--------|--------|--------|---------|
| Lumen maintenance factor | 1 | 0.96 | 0.94 | 0.93 | 0.92 | 0.91 | 0.90 | 0.86 |

EMERGENCY LUMENS (5000K 70CRI)

| | 12000LM | 18000LM | 24000LM | 30000LM | 35000LM | 40000LM | 45000LM |
|---------------------|---------|---------|---------|---------|---------|---------|---------|
| Narrow distribution | 3101 | 2820 | 2820 | 2820 | 2820 | 2820 | 2820 |
| Wide Distribution | 3117 | 2835 | 2835 | 2835 | 2835 | 2835 | 2835 |



JHBL LED IP Rated High Bay

PHOTOMETRICS

See www.lithonia.com.

SBGR – EMBEDDED Motion Sensor (see www.acuitycontrols.com for additional information)

- 360° coverage
- On/Off dim
- Photocell optional
- IP65 rated
- Photocell and 0-10VDC dimming options.
- Maximum ambient temperature 50°C

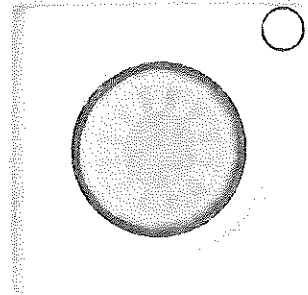

| Lithonia nomenclature | Sensor Switch* nomenclature |
|---|-----------------------------|
| For shortest lead times use one of the following SBGR configurations. | |
| MSE6NWL | SBGR 6 WH |
| MSE62L3VWL | SBGR 6 D WH 3V |
| MSE6NWL DSCNWL | SBGR 6 P WH |
| MSE10NWL | SBGR 10 WH |
| MSE102L3VWL | SBGR 10 D WH 3V |
| MSE10NWL DSCNWL | SBGR 10 P WH |

MOTION SENSOR

ORDERING INFORMATION Lead times will vary depending on options selected. Consult with your sales representative. **Example: MSE6NWL**

| Series | Lens option | Dimming | Environmental factors | Time delay |
|--|--|---|-----------------------|--|
| MSE Passive infrared embedded occupancy sensor | 6 High mount, 360° 10 Low mount, 360° | N On/off 2LXX Bi level range ¹ XA XPoint™ wireless signal to external system | WL Wet location | (blank) 10 minutes 5M 5 minutes 15M 15 minutes |

Notes

1 XX denotes "Low" level on 0-10V output.

PHOTOCELL

ORDERING INFORMATION Lead times will vary depending on options selected. Consult with your sales representative. **Example: DSCNWL**

| Series | Dimming | Environmental factors |
|--|---|-----------------------|
| DSC Closed loop (see external and fixture light) | N On/off CXX Continuous dimming and override off ¹ XA XPoint™ wireless signal to external system | WL Wet location |

Notes

1 Available with low mount only.



An AcuityBrands Company

JHBL LED IP Rated High Bay

COVERAGE PATTERNS

SITE & AREA LIGHTING / HIGH MOUNT APPLICATIONS

The **SBGR 6 ODP** is intended for higher applications, between 15-30 ft, and provides a coverage area radius for walking motion of 15-20 ft.

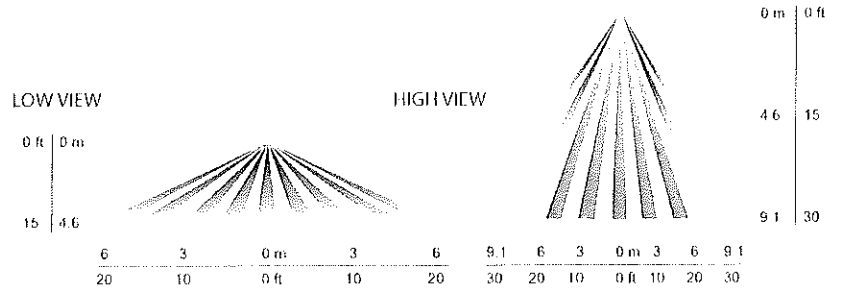

Coverage Pattern of High Mount Lens Option (SBGR 6 ODP)

LED IMPORTANT SAFETY INSTRUCTIONS

**READ AND FOLLOW ALL SAFETY INSTRUCTIONS!
SAVE THESE INSTRUCTIONS AND DELIVER TO OWNER AFTER INSTALLATION**

- To reduce the risk of death, personal injury or property damage from fire, electric shock, falling parts, cuts/abrasions, and other hazards please read all warnings and instructions included with and on the fixture box and all fixture labels.
- Before installing, servicing, or performing routine maintenance upon this equipment, follow these general precautions.
- Installation and service of luminaires should be performed by a **qualified licensed electrician**.
- Maintenance of the luminaires should be performed by person(s) familiar with the luminaires' construction and operation and any hazards involved. Regular fixture maintenance programs are recommended.
- It will occasionally be necessary to clean the outside of the refractor/lens. Frequency of cleaning will depend on ambient dirt level and minimum light output which is acceptable to user. Refractor/lens should be washed in a solution of warm water and any mild, non-abrasive household detergent, rinsed with clean water and wiped dry. Should optical assembly become dirty on the inside, wipe refractor/lens and clean in above manner, replacing damaged gaskets as necessary.
- **DO NOT INSTALL DAMAGED PRODUCT!** This luminaire has been properly packed so that no parts should have been damaged during transit. Inspect to confirm. Any part damaged or broken during or after assembly should be replaced.
- Recycle: For information on how to recycle LED electronic products, please visit www.epa.gov.
- These instructions do not purport to cover all details or variations in equipment nor to provide every possible contingency to meet in connection with installation, operation, or maintenance. Should further information be desired or should particular problems arise which are not covered sufficiently for the purchaser's or owner's purposes, this matter should be referred to Acuity Brands Lighting, Inc.



**WARNING
RISK OF ELECTRIC SHOCK**

- ✓ Disconnect or turn off power before installation or servicing.
- ✓ Verify that supply voltage is correct by comparing it with the luminaire label information.
- ✓ Make all electrical and grounded connections in accordance with the National Electrical Code (NEC) and any applicable local code requirements.
- ✓ All wiring connections should be capped with UL approved recognized wire connectors.



**WARNING
RISK OF BURN**

- ✓ Allow lamp/fixture to cool before handling. Do not touch enclosure or light source.
- ✓ Follow all manufacturer's warnings, recommendations and restrictions for: driver type, burning position, mounting locations/methods, replacement and recycling.



**CAUTION
RISK OF INJURY**

- ✓ Wear gloves and safety glasses at all times when removing luminaire from carton, installing, servicing or performing maintenance.
- ✓ Avoid direct eye exposure to the light source while it is on.



**CAUTION
RISK OF FIRE**

- ✓ Keep combustible and other materials that can burn, away from lamp/lens.
- ✓ Do not operate in close proximity to persons, combustible materials or substances affected by heat or drying.

LED IMPORTANT SAFETY INSTRUCTIONS



CAUTION: RISK OF PRODUCT DAMAGE

- ✓ Never connect components under load.
- ✓ Do not mount or support these fixtures in a manner that can cut the outer jacket or damage wire insulation.
- ✓ Unless individual product specifications deem otherwise: Never connect an LED product directly to a dimmer packs, occupancy sensors, timing devices, or other related control devices. LED fixtures must be powered directly off a switched circuit.
- ✓ Unless individual product specifications deem otherwise: Do not restrict fixture ventilation. Allow for some volume of airspace around fixture. Avoid covering LED fixtures with insulation, foam, or other material that will prevent convection or conduction cooling.
- ✓ Unless individual product specifications deem otherwise: Do not exceed fixtures maximum ambient temperature.
- ✓ Only use fixture in its intended location.
- ✓ Electrostatic Discharge (ESD): ESD can damage LED fixtures. Personal grounding equipment must be worn during all installation or servicing of the unit.
- ✓ Do not touch individual electrical components as this can cause ESD, shorten lamp life, or alter performance.
- ✓ Some components inside the fixture may not be serviceable. In the unlikely event your unit may require service, stop using the unit immediately and contact an ABL representative for assistance.
- ✓ Always read the fixtures complete installation instructions prior to installation for any additional fixture specific warnings.

Please see product specific installation instructions for additional warnings or any applicable FCC or other regulatory statements.

Failure to follow any of these instructions could void product warranties. For a complete listing of product Terms and Conditions, please visit www.acuitybrands.com.

| | | | | |
|-------------------|-------------------|-----------------------------|----------------------------|---------------------------|
| Our Brands | Indoor/Outdoor | Indoor Lighting | Outdoor Lighting | Controls |
| | Lithonia Lighting | Gotham | American Electric Lighting | DARK TO LIGHT |
| | Carandini | Mark Architectural Lighting | Antique Street Lamps | Lighting Control & Design |
| | Holophane | Peerless | Hydrel | ROAM |
| | RELOC | Renaissance Lighting | Tersen | Sensor Switch |
| | | Winona Lighting | | Synergy |

Acuity Brands Lighting, Inc. assumes no responsibility for claims arising out of improper or careless installation or handling of its products.

ABL LED General Warnings, Form No. 503.203

© 2010 Acuity Brands Lighting, Inc. All rights reserved. 12/01/10

Twin Arm Mount Accessory Kit for JHBL

1 INTRODUCTION

This optional mounting accessory is a twin arm mount that is intended to support two JHBL pendant mount fixtures. Twin Arm Mount weighs 10 Pounds. Single JHBL weight = 45 pounds. Total assembly weight of Twin Arm Mount and two JHBL fixtures = 100 pounds to 105 pounds depending on fixture accessories. This assembly is damp location listed only and is not IP rated.

2 INSTALLATION

2.1 Remove twin arm top covers. See figure 1

2.2 To attach fixtures to twin arm, feed fixture's lead wires thru twin arm nipples. Add additional wire if needed. Thread fixtures onto twin arm nipples, minimum 4 turns, until tight.

2.3 Hand tighten $\frac{3}{4}$ " Lock Nut until it seats securely onto fixture then turn an additional $\frac{1}{2}$ turn with wrench to secure. Teeth of lock nut must "bite" into the top of the fixture. See figure 2

WARNING

FAILURE TO TIGHTEN $\frac{3}{4}$ " LOCK NUTS COULD CAUSE FIXTURE TO FALL RESULTING IN INJURY, DEATH OR SERIOUS PROPERTY DAMAGE.

2.4 Connect fixture lead wires to supply wiring provided by others. Ensure twin arm is grounded using lead provided.

2.5 Re-attach twin arm covers. Slide twin arm mounting bracket until fixture weights are balanced. See figure 1

WARNING

FAILURE TO INSTALL TWIN ARM COVERS COULD CAUSE FIXTURE TO FALL RESULTING IN INJURY, DEATH OR SERIOUS PROPERTY DAMAGE

2.6 Install twin arm assembly by means of $\frac{3}{4}$ " NPT hook or loop only. Attached hook or loop to twin arm mount bracket, minimum 5 turns, until tight. Fixture must be mounted to a suitable structure capable of supporting the full weight of the assembly in accordance with local codes.

2.7 Tighten twin arm set screw to 25-35 in-lb. See figure 1.

WARNING

FAILURE TO TIGHTEN SET SCREW COULD CAUSE FIXTURE TO FALL RESULTING IN INJURY, DEATH OR SERIOUS PROPERTY DAMAGE.

3. Limited Warranty and Limitation of Liability

5-year limited warranty. Complete warranty terms located at:

www.acuitybrands.com/CustomerResources/Terms_and_Conditions.aspx.

Figure 1

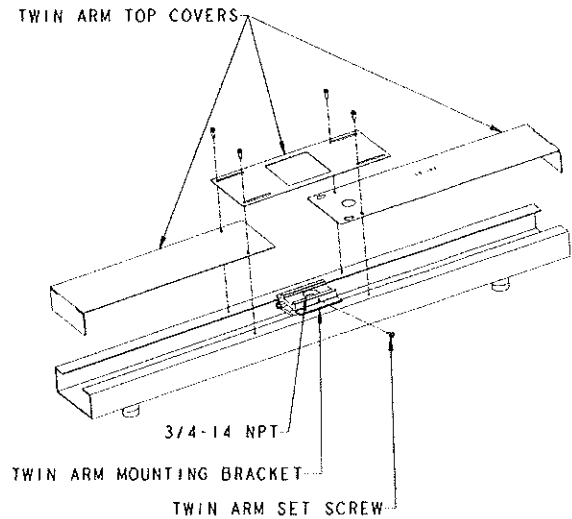
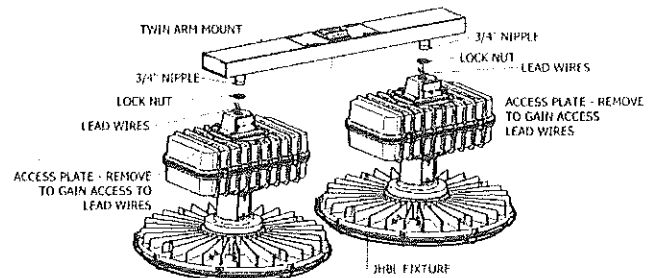

Figure 2



FEATURES & SPECIFICATIONS

INTENDED USE — The GTL LED recessed troffer offers a wide range of lumen packages, color temperatures, and lens options to meet the lighting needs for a wide range of applications such as schools, offices, and hospitals. The light engine delivers long life and excellent color to ensure a sound quality, low-maintenance lighting installation. **Certain airborne contaminants can diminish integrity of acrylic. Click here for Acrylic Environmental Compatibility table for suitable uses.**

CONSTRUCTION — Housing formed from 22 gauge cold-rolled steel. Smooth hemmed sides and smooth inward formed end flanges for safe handling. Lighter-weight fixture allows for safe, easy installation.

OPTICS — Highly transmissive pattern #12 lens diffuses the light source without compromising output. Pattern # 19 and satin white lens options also available.

ELECTRICAL — Long-life LEDs, coupled with high-efficiency drivers, provide extended service life. 90% LED lumen maintenance at 60,000 hours (L90/60,000).

elddLED driver options deliver choice of dimming range, and choices for control, while assuring flicker-free, low-current inrush, 89% efficiency and low EMI.

Optional nLight® embedded controls make each luminaire addressable - allowing it to digitally communicate with other nLight enabled controls such as dimmers, switches, occupancy sensors and photocontrols. Simply connect all the nLight enabled control devices and the GTL luminaires using standard Cat-5 cabling. Unique plug-and-play convenience as devices and luminaires automatically discover each other and self-commission.

Lumen Management: Unique lumen management system (option N80) provides onboard intelligence that actively manages the LED light source so that constant lumen output is maintained over the system life, preventing the energy waste created by the traditional practice of over-lighting.

The step-level dimming option (SLD) allows the system to be switched to 50% power for compliance with common energy codes while maintaining fixture appearance.

Ballast disconnect is provided where required to comply with U.S. and Canadian codes.

INSTALLATION — LED boards include plug-in connectors for easy of upgradeability. Suitable for direct insulation contact. Suitable for damp location.

LISTINGS — CSA certified to meet U.S. and Canadian standards. IC rated. DesignLights Consortium® (DLC) Premium qualified product. Not all versions of this product may be DLC Premium qualified. Please check the DLC Qualified Products List at www.designlights.org/QPL to confirm which versions are qualified.

WARRANTY — 5-year limited warranty. Complete warranty terms located at www.acuitybrands.com/CustomerResources/Terms_and_conditions.aspx

Note: Actual performance may differ as a result of end-user environment and application.

All values are design or typical values, measured under laboratory conditions at 25 °C.

Specifications subject to change without notice.

GTL Series

GTL

1' x 4'
LED Recessed Troffer

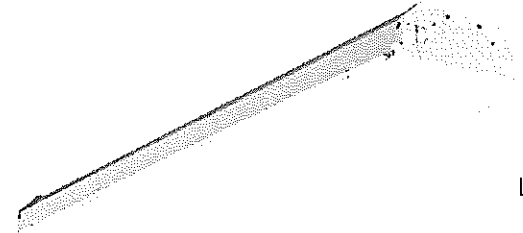

Specifications

Length: 48 (122.0)
Width: 12 (30.5)
Depth: 4.5 (11.4)

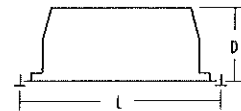

All dimensions are inches (centimeters) unless otherwise indicated.

CSA+ Capable Luminaire

This item is an A+ capable luminaire, which has been designed and tested to provide consistent color appearance and out-of-the-box control compatibility with simple commissioning.

- All configurations of this luminaire meet the Acuity Brands' specification for chromatic consistency
- This luminaire is part of an A+ Certified solution for nLight® control networks when ordered with drivers marked by a shaded background*
- This luminaire is part of an A+ Certified solution for nLight control networks, providing advanced control functionality at the luminaire level, when selection includes driver and control options marked by a shaded background*

To learn more about A+, visit www.acuitybrands.com/aplus.

*See ordering tree for details

GTL LED Troffer



A+ Capable options indicated by this color background.

ORDERING INFORMATION Lead times will vary depending on options selected. Consult with your sales representative. **Example: GTL 4 40L EZ1 LP835**

| GTL | 4 | | 40L | | A19 | | EZ1 | LP835 |
|--------------------------------------|--------|--------------------------------------|---|--|--|---|--|---|
| Series | Length | Trim type | Lumens ¹ | Door | Lens | Voltage | Driver | Color temperature |
| (GTL) 1' wide recessed LED luminaire | (4) 4' | (blank) Grid F Overlapping flange | 20L 2000 lumens 33L 3300 lumens 40L 4000 lumens 48L 4800 lumens | (blank) Flush steel, white FN Flush aluminum, natural FM Flush aluminum, matte black FW Flush aluminum, white RN Regressed aluminum, natural RM Regressed aluminum, matte black RW Regressed aluminum, white | (blank) #12 pattern acrylic, 0.125" thick (A19) #19 pattern acrylic, 0.156" thick SWL Satin white | (blank) MVOLT (120-277V) 120 120V 277 277V 347 347V ² | EZ1 eidoLED dims to 1% SLD Step-level dimming ³ EXA1 eidoLED dims to 1%, XPoint wireless enabled | LP830 3000 K LP835 3500 K LP840 4000 K LP850 5000 K |

| Controls ^{4,5} | Options |
|---|---|
| (blank) No controls | EL7L Nominal 700 lumen emergency battery ³ |
| N80 nLight with 80% (L80) lumen management | EL14L Nominal 1400 lumen emergency battery ³ |
| N80EMG nLight with 80% (L80) lumen management for use with generator supply emergency power | CP Chicago plenum |
| N100 nLight without lumen management | PWS1836 6' pre-wire, 3/8" diameter, 18-gauge, 1-circuit |
| N100EMG nLight without lumen management for use with generator supply emergency power | PWS1846 6' pre-wire, 3/8" diameter, 18-gauge, 2-circuit |
| | ABC Door frame gasketing ⁶ |
| | GLR Fast-blowing fuse ⁷ |
| | GMF Slow-blowing fuse ⁷ |
| | LATC Earthquake clip |
| | NPLT Narrow pallet |
| | PAF Paint after fab |

Accessories: Order as separate catalog number.
DGA14 Drywall grid adapter for 1x4 recessed fixture.

- Notes**
- 1 Approximate lumen output. Lumen output will vary depending upon lens option chosen.
 - 2 Not available with EL7L, EL14L, or SLD.
 - 3 When using pre-wire option, use PWS1846.
 - 4 Not available with SLD.
 - 5 Cannot row mount when ordered with nLight options
 - 6 Only available with aluminum door.
 - 7 Must specify voltage, 120 or 277.

| Performance Data | | | |
|------------------|-------------|--------|--------|
| Lumen Package | Input Watts | Lumens | LPW |
| 20L LP830 | 20.5 | 1954.6 | 95.35 |
| 20L LP835 | 20.5 | 2052.3 | 100.11 |
| 20L LP840 | 20.5 | 2150 | 104.88 |
| 20L LP850 | 20.5 | 2169.6 | 105.83 |
| 33L LP830 | 35.2 | 3242.7 | 92.12 |
| 33L LP835 | 35.2 | 3401 | 96.62 |
| 33L LP840 | 35.2 | 3557.4 | 101.06 |
| 33L LP850 | 35.2 | 3644.5 | 103.54 |
| 40L LP830 | 40.1 | 3572.2 | 89.08 |
| 40L LP835 | 40.1 | 3750.9 | 93.54 |
| 40L LP840 | 40.1 | 3938.5 | 98.22 |
| 40L LP85 | 40.1 | 4025.9 | 100.40 |
| 48L LP830 | 46.46 | 4280.6 | 92.14 |
| 48L LP835 | 46.46 | 4493.6 | 96.72 |
| 48L LP840 | 46.46 | 4718.4 | 101.56 |
| 48L LP850 | 46.46 | 4822 | 103.79 |

Note: Performance based on standard #12 pattern acrylic lens.

MOUNTING DATA

Continuous row mounting of flanged units requires CRE and CRM trim options (see Options).

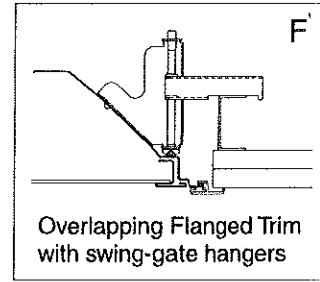
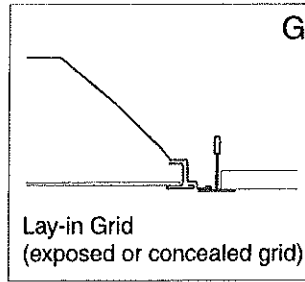

NOTE:

- 1 Recommended rough-in dimensions for F-trim fixtures 12"x48" (Tolerance is +1/4"-0"). Swing-gate range 1-3/16" to 3-15/16". Swing-gate span 23-3/8" to 26-11/16". Fixture swing-gate points require additional 1-1/16" over nominal fixture height.

PHOTOMETRICS

GTL 40L EZ1 LP835, 3751 delivered lumens, test no. LTL26527P9, tested in accordance to IESNA LM-79.

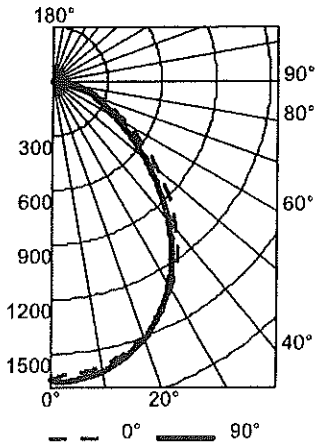

CP Summary

| | 0° | 90° |
|-----|------|------|
| 0° | 1647 | 1647 |
| 5° | 1614 | 1648 |
| 15° | 1554 | 1577 |
| 25° | 1420 | 1412 |
| 35° | 1203 | 1155 |
| 45° | 915 | 831 |
| 55° | 616 | 526 |
| 65° | 365 | 311 |
| 75° | 194 | 186 |
| 85° | 73 | 65 |
| 90° | 0 | 0 |

Coefficients of Utilization

| ROR | pf | 20% | | | | | | 50% | | | | | |
|-----|-----|-----|-----|-----|-----|-----|-----|-----|-----|-----|-----|-----|-----|
| | | pc | 80% | | 70% | | 50% | | 30% | | 10% | | |
| | pw | 70% | 50% | 30% | 50% | 30% | 10% | 50% | 30% | 10% | 50% | 30% | 10% |
| 0 | 119 | 119 | 119 | 116 | 116 | 116 | 111 | 111 | 111 | | | | |
| 1 | 110 | 105 | 101 | 103 | 99 | 96 | 99 | 96 | 93 | | | | |
| 2 | 101 | 93 | 87 | 91 | 85 | 80 | 88 | 83 | 78 | | | | |
| 3 | 92 | 83 | 75 | 81 | 74 | 68 | 78 | 72 | 67 | | | | |
| 4 | 85 | 74 | 66 | 73 | 65 | 59 | 70 | 63 | 58 | | | | |
| 5 | 79 | 67 | 58 | 65 | 58 | 52 | 63 | 56 | 51 | | | | |
| 6 | 73 | 60 | 52 | 59 | 51 | 46 | 58 | 51 | 45 | | | | |
| 7 | 68 | 55 | 47 | 54 | 46 | 41 | 53 | 46 | 40 | | | | |
| 8 | 63 | 50 | 42 | 50 | 42 | 37 | 49 | 41 | 36 | | | | |
| 9 | 59 | 47 | 39 | 46 | 38 | 33 | 45 | 38 | 33 | | | | |
| 10 | 56 | 43 | 35 | 43 | 35 | 30 | 42 | 35 | 30 | | | | |

Zonal Lumen Summary

| Zone | Lumens | % Lamp | % Fixture |
|------------|--------|--------|-----------|
| 0° - 30° | 1250 | 33.3 | 33.3 |
| 0° - 40° | 1984 | 52.9 | 52.9 |
| 0° - 60° | 3160 | 84.2 | 84.2 |
| 0° - 90° | 3751 | 100.0 | 100.0 |
| 90° - 120° | 0 | 0.0 | 0.0 |
| 90° - 130° | 0 | 0.0 | 0.0 |
| 90° - 150° | 0 | 0.0 | 0.0 |
| 90° - 180° | 0 | 0.0 | 0.0 |
| 0° - 180° | 3751 | 100.0 | 100.0 |

Constant Lumen Management

Enabled by the embedded nLight control, the GTL actively tracks its run-time and manages its light source such that constant lumen output is maintained over the system life. Referred to as lumen management, this feature eliminates the energy waste created by the traditional practice of over-lighting.

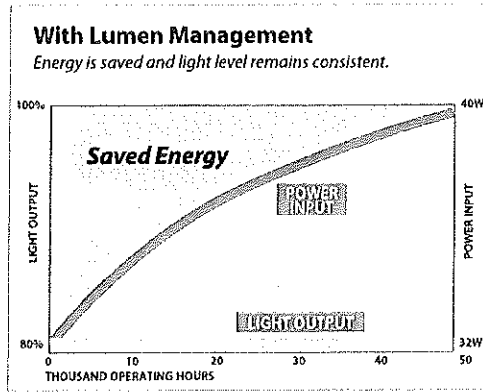
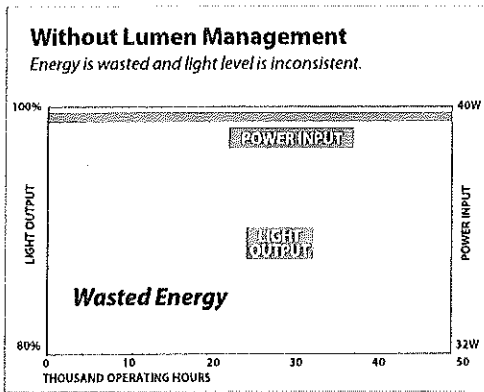

FEATURES & SPECIFICATIONS

INTENDED USE — The GTL LED recessed troffer offers a wide range of lumen packages, color temperatures, and lens options to meet the lighting needs for a wide range of applications such as schools, offices, and hospitals. The light engine delivers long life and excellent color to ensure a sound quality, low-maintenance lighting installation. **Certain airborne contaminants can diminish integrity of acrylic. Click here for Acrylic Environmental Compatibility table for suitable uses.**

CONSTRUCTION — Housing formed from 22 gauge cold-rolled steel. Smooth hemmed sides and smooth inward formed end flanges for safe handling. Lighter-weight fixture allows for safe, easy installation.

OPTICS — Highly transmissive pattern #12 lens diffuses the light source without compromising output. Pattern # 19 and satin white lens options also available.

ELECTRICAL — Long-life LEDs, coupled with high-efficiency drivers, provide extended service life. 90% LED lumen maintenance at 60,000 hours (L90/60,000).

elddotLED driver options deliver choice of dimming range, and choices for control, while assuring flicker-free, low-current inrush, 89% efficiency and low EMI.

Optional nLight® embedded controls make each luminaire addressable - allowing it to digitally communicate with other nLight enabled controls such as dimmers, switches, occupancy sensors and photocontrols. Simply connect all the nLight enabled control devices and the GTL luminaires using standard Cat-5 cabling. Unique plug-and-play convenience as devices and luminaires automatically discover each other and self-commission.

Lumen Management: Unique lumen management system (option N80) provides onboard intelligence that actively manages the LED light source so that constant lumen output is maintained over the system life, preventing the energy waste created by the traditional practice of over-lighting.

The step-level dimming option (SLD) allows the system to be switched to 50% power for compliance with common energy codes while maintaining fixture appearance.

Ballast disconnect is provided where required to comply with U.S. and Canadian codes.

INSTALLATION — LED boards include plug-in connectors for easy of upgradeability. Suitable for direct insulation contact. Suitable for damp location.

LISTINGS — CSA certified to meet U.S. and Canadian standards. IC rated. DesignLights Consortium® (DLC) Premium qualified product. Not all versions of this product may be DLC Premium qualified. Please check the DLC Qualified Products List at www.designlights.org/QPL to confirm which versions are qualified.

WARRANTY — 5-year limited warranty. Complete warranty terms located at www.acuitybrands.com/CustomerResources/Terms_and_conditions.aspx

Note: Actual performance may differ as a result of end-user environment and application.

All values are design or typical values, measured under laboratory conditions at 25 °C.

Specifications subject to change without notice.

GTL Series

GTL

1' x 4'

LED Recessed Troffer

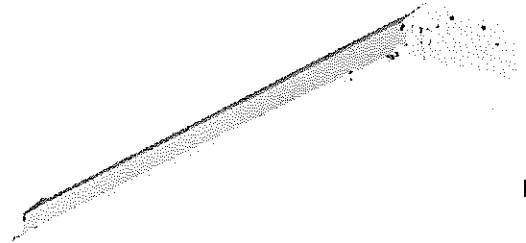

Specifications

Length: 48 (122.0)

Width: 12 (30.5)

Depth: 4.5 (11.4)

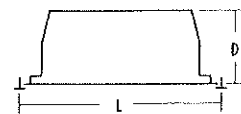

All dimensions are inches (centimeters) unless otherwise indicated.

CSA+ Capable Luminaire

This item is an A+ capable luminaire, which has been designed and tested to provide consistent color appearance and out-of-the-box control compatibility with simple commissioning.

- All configurations of this luminaire meet the Acuity Brands' specification for chromatic consistency
- This luminaire is part of an A+ Certified solution for nLight® control networks when ordered with drivers marked by a shaded background*
- This luminaire is part of an A+ Certified solution for nLight control networks, providing advanced control functionality at the luminaire level, when selection includes driver and control options marked by a shaded background*

To learn more about A+, visit www.acuitybrands.com/aplus.

*See ordering tree for details

GTL LED Troffer



A+ Capable options indicated by this color background.

ORDERING INFORMATION Lead times will vary depending on options selected. Consult with your sales representative. **Example:** GTL 4 40L EZ1 LP835

| GTL | 4 | | 40L | | A19 | | EZ1 | LP835 |
|------------------------------------|--------|--------------------------------------|---|--|--|---|--|---|
| Series | Length | Trim type | Lumens ¹ | Door | Lens | Voltage | Driver | Color temperature |
| GTL 1' wide recessed LED luminaire | 4 4' | (blank) Grid F Overlapping flange | 20L 2000 lumens 33L 3300 lumens 40L 4000 lumens 48L 4800 lumens | (blank) Flush steel, white FN Flush aluminum, natural FM Flush aluminum, matte black FW Flush aluminum, white RN Regressed aluminum, natural RM Regressed aluminum, matte black RW Regressed aluminum, white | (blank) #12 pattern acrylic, 0.125" thick A19 #19 pattern acrylic, 0.156" thick SWL Satin white | (blank) MVOLT (120-277V) 120 120V 277 277V 347 347V ² | EZ1 eldoLED dims to 1% SLD Step-level dimming ³ EXA1 eldoLED dims to 1%, XPoint wireless enabled | LP830 3000 K LP835 3500 K LP840 4000 K LP850 5000 K |

| Controls ^{4,5} | Options |
|---|--|
| (blank) No controls | EL7L Nominal 700 lumen emergency battery ³ |
| N80 nLight with 80% (L80) lumen management | EL14L Nominal 1400 lumen emergency battery ³ |
| N80EMG nLight with 80% (L80) lumen management for use with generator supply emergency power | CP Chicago plenum |
| N100 nLight without lumen management | PWS1836 6' pre-wire, 3/8" diameter, 18-gauge, 1-circuit |
| N100EMG nLight without lumen management for use with generator supply emergency power | PWS1846 6' pre-wire, 3/8" diameter, 18-gauge, 2-circuit |
| | ABC Door frame gasketing ⁶ |
| | GLR Fast-blowing fuse ⁷ |
| | GMF Slow-blowing fuse ⁷ |
| | LATC Earthquake clip |
| | NPLT Narrow pallet |
| | PAF Paint after fab |

Accessories: Order as separate catalog number.
DGA14 Drywall grid adapter for 1x4 recessed fixture.

- Notes**
- 1 Approximate lumen output. Lumen output will vary depending upon lens option chosen.
 - 2 Not available with EL7L, EL14L, or SLD.
 - 3 When using pre-wire option, use PWS1846.
 - 4 Not available with SLD.
 - 5 Cannot row mount when ordered with nLight options
 - 6 Only available with aluminum door.
 - 7 Must specify voltage, 120 or 277.

| Performance Data | | | |
|------------------|-------------|--------|--------|
| Lumen Package | Input Watts | Lumens | LPW |
| 20L LP830 | 20.5 | 1954.6 | 95.35 |
| 20L LP835 | 20.5 | 2052.3 | 100.11 |
| 20L LP840 | 20.5 | 2150 | 104.88 |
| 20L LP850 | 20.5 | 2169.6 | 105.83 |
| 33L LP830 | 35.2 | 3242.7 | 92.12 |
| 33L LP835 | 35.2 | 3401 | 96.62 |
| 33L LP840 | 35.2 | 3557.4 | 101.06 |
| 33L LP850 | 35.2 | 3644.5 | 103.54 |
| 40L LP830 | 40.1 | 3572.2 | 89.08 |
| 40L LP835 | 40.1 | 3750.9 | 93.54 |
| 40L LP840 | 40.1 | 3938.5 | 98.22 |
| 40L LP85 | 40.1 | 4025.9 | 100.40 |
| 48L LP830 | 46.46 | 4280.6 | 92.14 |
| 48L LP835 | 46.46 | 4493.6 | 96.72 |
| 48L LP840 | 46.46 | 4718.4 | 101.56 |
| 48L LP850 | 46.46 | 4822 | 103.79 |

Note: Performance based on standard #12 pattern acrylic lens.

MOUNTING DATA

Continuous row mounting of flanged units requires CRE and CRM trim options (see Options).

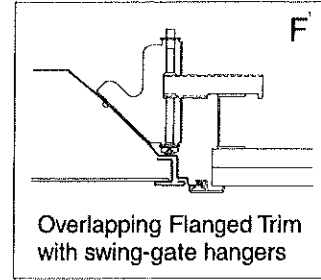
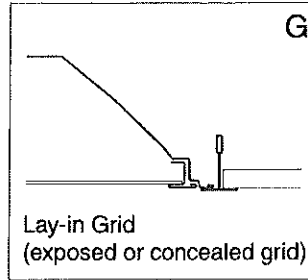

NOTE:

1 Recommended rough-in dimensions for F-trim fixtures 12"x48" (Tolerance is +1/4"-0"). Swing-gate range 1-3/16" to 3-15/16". Swing-gate span 23-3/8" to 26-11/16". Fixture swing-gate points require additional 1-1/16" over nominal fixture height.

PHOTOMETRICS

GTL4 40L EZ1 LP835, 3751 delivered lumens, test no. LTL26527P9, tested in accordance to IESNA LM-79.

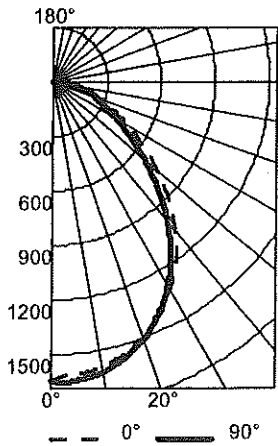

| CP Summary | | |
|------------|------|------|
| | 0° | 90° |
| 0° | 1647 | 1647 |
| 5° | 1614 | 1648 |
| 15° | 1554 | 1577 |
| 25° | 1420 | 1412 |
| 35° | 1203 | 1155 |
| 45° | 915 | 831 |
| 55° | 616 | 526 |
| 65° | 365 | 311 |
| 75° | 194 | 186 |
| 85° | 73 | 65 |
| 90° | 0 | 0 |

| ROR | pf | pc | Coefficients of Utilization | | | | | | | | |
|-----|-----|-----|-----------------------------|-----|-----|-----|-----|-----|-----|-----|-----|
| | | | 80% | | | 70% | | | 50% | | |
| | | | 70% | 50% | 30% | 50% | 30% | 10% | 50% | 30% | 10% |
| 0 | 119 | 119 | 119 | 116 | 116 | 116 | 111 | 111 | 111 | | |
| 1 | 110 | 105 | 101 | 103 | 99 | 96 | 99 | 96 | 93 | | |
| 2 | 101 | 93 | 87 | 91 | 85 | 80 | 88 | 83 | 78 | | |
| 3 | 92 | 83 | 75 | 81 | 74 | 68 | 78 | 72 | 67 | | |
| 4 | 85 | 74 | 66 | 73 | 65 | 59 | 70 | 63 | 58 | | |
| 5 | 79 | 67 | 58 | 65 | 58 | 52 | 63 | 56 | 51 | | |
| 6 | 73 | 60 | 52 | 59 | 51 | 46 | 58 | 51 | 45 | | |
| 7 | 68 | 55 | 47 | 54 | 46 | 41 | 53 | 46 | 40 | | |
| 8 | 63 | 50 | 42 | 50 | 42 | 37 | 49 | 41 | 36 | | |
| 9 | 59 | 47 | 39 | 46 | 38 | 33 | 45 | 38 | 33 | | |
| 10 | 56 | 43 | 35 | 43 | 35 | 30 | 42 | 35 | 30 | | |

| Zonal Lumen Summary | | | |
|---------------------|--------|--------|-----------|
| Zone | Lumens | % Lamp | % Fixture |
| 0° - 30° | 1250 | 33.3 | 33.3 |
| 0° - 40° | 1984 | 52.9 | 52.9 |
| 0° - 60° | 3160 | 84.2 | 84.2 |
| 0° - 90° | 3751 | 100.0 | 100.0 |
| 90° - 120° | 0 | 0.0 | 0.0 |
| 90° - 130° | 0 | 0.0 | 0.0 |
| 90° - 150° | 0 | 0.0 | 0.0 |
| 90° - 180° | 0 | 0.0 | 0.0 |
| 0° - 180° | 3751 | 100.0 | 100.0 |

Constant Lumen Management

Enabled by the embedded nLight control, the GTL actively tracks its run-time and manages its light source such that constant lumen output is maintained over the system life. Referred to as lumen management, this feature eliminates the energy waste created by the traditional practice of over-lighting.

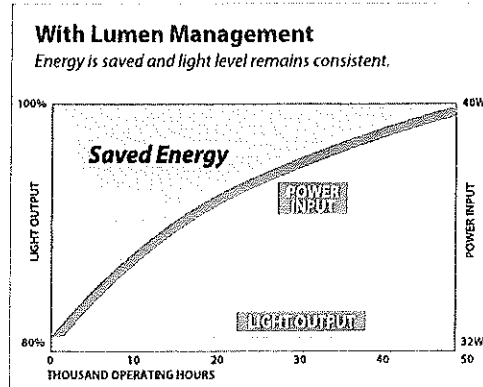
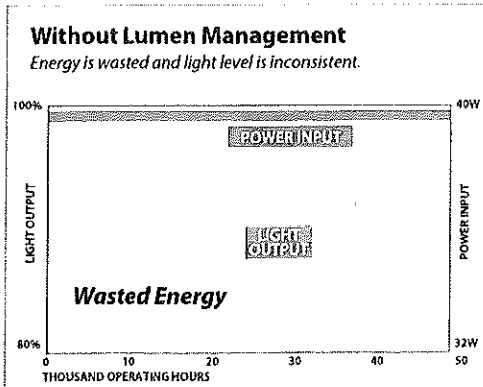

MILLENNIUM STRETCH™

MLHA8 SERIES

PRODUCT FEATURES:

- » Surface mount – wall or ceiling; nominal 8" x 24", 8" x 36", 8" x 48", 8" x 72", 8" x 96"
- » Extruded aluminum housing with decorative end caps
- » Peace of Mind Guarantee® against breakage
- » ADA compliant

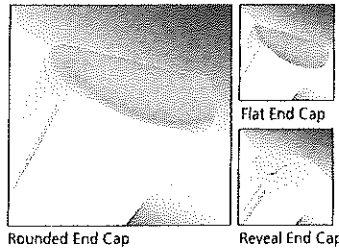

MLHA8 48 F MW PP 45L35K DCC DV

LEMONWOOD K-8 RECONSTRUCCION

5

SPECIFICATIONS

HOUSING: Marine grade aluminum. Extruded body with die-cast end caps. Housing, with end caps, post assembly TGIC polyester powder coat finished – 5-step pre-treatment. See Ordering Information for standard, optional, architectural and custom finishes.

REFLECTOR: Full reflector/wire cover – 92% reflectivity.

LENS: UV-stabilized, high impact extruded clear or pearlescent polycarbonate. Smooth exterior, linear prismatic interior. Nominal thickness .156". Lens securely positioned in body channels and end caps. Lens locked in place with tamper-resistant stainless steel Torx® with center pin fasteners and sealed with closed cell gaskets.

END CAPS: Marine grade die-cast aluminum. Three styles available: Flat, Rounded and Reveal. Conduit and "Wiremold"™ ready knockouts visible only from interior of end cap (Flat and Rounded styles only).

SOCKETS: Shock-resistant sockets with internal locking collar to ensure positive lamp retention.

HARDWARE: Stainless steel, tamper-resistant Torx fasteners secure lens in housing body's lens channel (four on 24", 36", and 48" housings; eight on 72" and 96" housings).

ELECTRICAL: LED: Available 3500K, 4000K and 5000K color temperatures, 82 CRI, 120-277VAC, 50/60Hz electrical input with serviceable high power factor electronic, constant-current driver (<20% THD, >0.95 PF). Standard 0-10V dimming with 1-100% range, maximum driver source of 500 µA. LE: Class P ballasts. Fluorescent electronic 120/277/347 and dual voltage ballasts high power factor.

INSTALLATION: Standard four-point (24" housing), six-point (36" and 48" housing) and twelve-point (72" and 96" housing) mounting required for Peace of Mind Guarantee®. LED product ambient temperature is -30°C to 25°C, unless otherwise noted.

PHOTOMETRICS: Photometry tested to the IESNA LM-79-08 standard by an ILAC/ISO 17025 accredited laboratory. For additional photometric information, go to www.kenall.com.

WARRANTY: Limited ten (10) year warranty for LED Lamps.

LISTINGS: UL and CUL listed for Wet Location – covered ceiling mount. UL certified IP64 in compliance with IEC 60598 – ceiling mount. Corner, horizontal wall and pendant mount installation – damp location only. ADA compliant. Product listed on the Designlights Consortium® Qualified Products List. Check the latest version [here](#) for listed configuration details.



ORDERING INFORMATION (Ex: MLHA8-48-F-MB-PP-45L40K-DCC-DV-FS-9500)

| Model | Length | End Cap | Finish | Lens | Lamp Qty | Lamp Type | Ballast/Driver Type | Circuit Qty | Voltage | Options | Accessories |
|--------------|-----------|----------|-----------|-----------|----------|---------------|---------------------|-------------|-----------|---------|-------------|
| MLHA8 | 48 | F | MW | PP | | 45L35K | DCC | | DV | | |

| | | | |
|---|---|---|--|
| Length | Lamp Type | Circuit Quantity (n/a with LED) | Accessories |
| 24 2' | 2' Lengths | 1 One | CMB1 Corner Mount Bracket (Must be ordered with DL Option) |
| 36 3' | 25L35K 25 Watt 3500K LED | 2† Two (2 Ballast minimum) | 9500 Torx® Screwdriver |
| 48 4' | 25L40K 25 Watt 4000K LED | | D-0552 Torx Driver Bit (Required for CMB Option) |
| 72 Two 3' (factory connected) | 25L50K 25 Watt 5000K LED | Voltage | |
| 96 Two 4' (factory connected) | 14 F14T5 (rapid start only) | 120 120 Volts | |
| End Caps | 17 F17T8 | 277 277 Volts | |
| F Flat | 24▲ F24T5HO (rapid start only) | 347 347 Volts (Consult Factory) | † n/a on 2' T5/T5HO or 3' T5HO fixtures with EL, PEL or TN options |
| R Rounded | 3' Lengths | DV 120-277 Volts | ▲ n/a with 347V |
| RV Reveal | 21 F21T5 (rapid start only) | Options | ▼ 2' Fixtures have minimum 350-450 lumen battery pack |
| Finish | 25 F25T8 | EL▲•§ 500 Minimum Lumen Battery Pack (90 Minutes; 32°F Starting Temp) | ■ n/a on 2' fixtures |
| LG Light Gray | 39 F39T5HO (rapid start only) | PEL▲•§ 1100 Minimum Lumen Battery Pack (90 Minutes; 32°F Starting Temp) | § n/a with 3 lamps |
| MB Matte Black | 4' Lengths | LLE LED Emergency Battery Backup (4' only) (45L max, 32°F minimum operating temperature) | • n/a with LED Lamp Type |
| MW Matte White | 45L35K 45 Watt 3500K LED | CDF Captive Diffuser Fasteners | † PM and CMB not available in conjunction |
| CC Custom Color (Consult Factory) | 45L40K 45 Watt 4000K LED | DL Damp Location (Interior use NO gasketing) | 3500K LAMPS INCLUDED SEPARATELY |
| Lens | 45L50K 45 Watt 5000K LED | FS Single Fuse & Holder (one per circuit) | |
| CP Clear Polycarbonate | 67L35K 67 Watt 3500K LED | NAT§ Natatorium Environment Option | |
| PP Pearlescent Polycarbonate | 67L40K 67 Watt 4000K LED | PH Phillips Head Fasteners | |
| Lamp Quantity (Cross Section) (n/a with LED) | 67L50K 67 Watt 5000K LED | PM§† Pendant Mount (stems by others; damp only) | |
| 1 One | 90L35K 90 Watt 3500K LED | TN§ • Twin Tube Night Light – 5/7/9 watts (120V only) | |
| 2 Two | 90L40K 90 Watt 4000K LED | UC§ • Uplight Component (Pendant Mount only; stems by others; damp only) | |
| 3 Three (T8 or T5 only) | 90L50K 90 Watt 5000K LED | | |
| | 28 F28T5 (rapid start only) | | |
| | 32 F32T8 | | |
| | 54 F54T5HO (rapid start only) | | |
| | 54A F54T5HO amalgam (rapid start only) | | |
| | Ballast/Driver Type | | |
| | IS Instant Start Electronic <10% THD (T8) | | |
| | RS Rapid Start Electronic <10% THD (T8, T5, T5HO) | | |
| | SB Specified Ballast | | |
| | DCC Dimming Constant Current (LED) | | |



www.kenall.com

P: 800-4-Kenall

F: 262-891-9701

10200 55th Street Kenosha, Wisconsin 53144

When you see this image, you will know the Kenall product shown or described is designed and manufactured in the USA with components purchased from US suppliers, and meets the Buy American requirements under the ARRA. Kenall has not determined the origin of its domestically purchased components or the subcomponents thereof. May be covered by patents found at www.kenall.com/patents. Content of specification sheets is subject to change; please consult www.kenall.com for current product details. © 2015 Kenall Mfg. Co. All rights reserved.

MLHA8-0222.16

MILLENNIUM STRETCH™

MLHA8 SERIES

PERFORMANCE

| Length | Lamp Type | Initial Delivered Lumens | | Input Power (W) | Drive Current (mA) | Estd. L70 LED Life (Hrs) |
|--------|-----------|--------------------------|-----------------|-----------------|--------------------|--------------------------|
| | | @ 25°C | Efficacy (lm/W) | | | |
| 2' | 25L35K | 2316 | 93 | 25 | 94 | 80,000 |
| | 25L40K | 2469 | 99 | 25 | 94 | 80,000 |
| | 25L50K | 2568 | 103 | 25 | 94 | 80,000 |
| 4' | 45L35K | 4632 | 95 | 50 | 94 | 80,000 |
| | 45L40K | 4938 | 101 | 50 | 94 | 80,000 |
| | 45L50K | 5136 | 103 | 50 | 94 | 80,000 |
| | 67L35K | 6640 | 89 | 74 | 66 | 80,000 |
| | 67L40K | 7078 | 95 | 74 | 66 | 80,000 |
| | 67L50K | 7362 | 99 | 74 | 66 | 80,000 |
| | 90L35K | 8445 | 84 | 100 | 94 | 60,000 |
| | 90L40K | 9003 | 90 | 100 | 94 | 60,000 |
| 90L50K | 9363 | 93 | 100 | 94 | 60,000 | |

Information above is valid for the recommended Type PP lens type and is subject to change without notice. Visit www.kenall.com for IES files and additional information.

Model: MLHA8-48-F-MW-PP-45L40K-DCC-DV

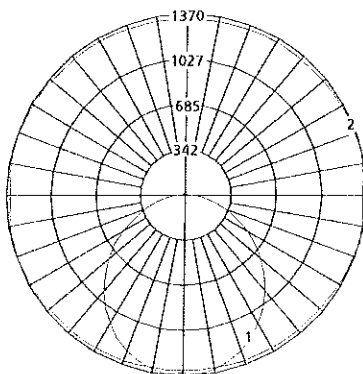

Maximum Candela = 1370 Located At Horizontal Angle = 15, Vertical Angle = 5

- 1 - Vertical Plane Through Horizontal Angles (15-195) (Through Max. Cd.)
- 2 - Horizontal Cone Through Vertical Angle (5) (Through Max. Cd.)

DIMENSIONAL DATA

CROSS SECTION/DETAILS

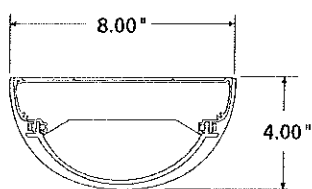

MOUNTING HOLES

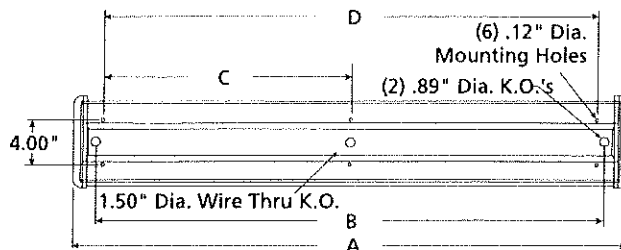

CORNER MOUNT BRACKET

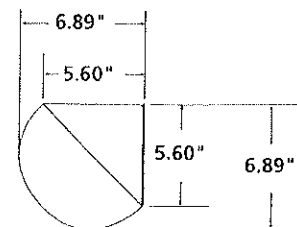

Nominal Two Foot Fixture Legend

| LMP End Cap | A | B | C | D |
|-------------|--------|--------|-----|--------|
| T8 R | 26.524 | 22.312 | N/A | 21.000 |
| T8 F | 25.308 | 22.312 | N/A | 21.000 |
| T8 RV | 28.632 | 22.312 | N/A | 21.000 |
| T5 R | 24.940 | 20.728 | N/A | 20.875 |
| T5 F | 23.724 | 20.728 | N/A | 20.875 |
| T5 RV | 27.048 | 20.728 | N/A | 20.875 |

Nominal Three Foot Fixture Legend

| LMP End Cap | A | B | C | D |
|-------------|--------|--------|--------|--------|
| T8 R | 38.524 | 34.312 | 16.500 | 33.000 |
| T8 F | 34.312 | 34.312 | 16.500 | 33.000 |
| T8 RV | 40.632 | 34.312 | 16.500 | 33.000 |
| T5 R | 36.751 | 32.540 | 16.344 | 32.688 |
| T5 F | 35.535 | 32.540 | 16.344 | 32.688 |
| T5 RV | 38.859 | 32.540 | 16.344 | 32.688 |

Nominal Four Foot Fixture Legend

| LMP End Cap | A | B | C | D |
|-------------|--------|--------|--------|--------|
| T8/LED R | 50.524 | 46.312 | 22.500 | 45.000 |
| T8/LED F | 49.308 | 46.312 | 22.500 | 45.000 |
| T8/LED RV | 52.632 | 46.312 | 22.500 | 45.000 |
| T5 R | 48.562 | 44.350 | 22.250 | 44.500 |
| T5 F | 47.346 | 44.350 | 22.250 | 44.500 |
| T5 RV | 50.670 | 44.350 | 22.250 | 44.500 |



www.kenall.com

P: 800-4-Kenall

F: 262-891-9701

10200 55th Street Kenosha, Wisconsin 53144

When you see this image, you will know the Kenall product shown or described is designed and manufactured in the USA with components purchased from US suppliers, and meets the Buy American requirements under the ARRA. Kenall has not determined the origin of its domestically purchased components or the subcomponents thereof. May be covered by patents found at www.kenall.com/patents. Content of specification sheets is subject to change; please consult www.kenall.com for current product details. © 2015 Kenall Mfg. Co. All rights reserved.

MILLENIUM STRETCH™

MLHA8 SERIES

PRODUCT FEATURES:

- » Surface mount – wall or ceiling; nominal 8" x 24", 8" x 36" 8" x 48", 8" x 72", 8" x 96"
- » Extruded aluminum housing with decorative end caps
- » Peace of Mind Guarantee® against breakage
- » ADA compliant

SPECIFICATIONS

HOUSING: Marine grade aluminum. Extruded body with die-cast end caps. Housing, with end caps, post assembly TGIC polyester powder coat finished – 5-step pre-treatment. See Ordering Information for standard, optional, architectural and custom finishes.

REFLECTOR: Full reflector/wire cover – 92% reflectivity.

LENS: UV-stabilized, high impact extruded clear or pearlescent polycarbonate. Smooth exterior, linear prismatic interior. Nominal thickness .156". Lens securely positioned in body channels and end caps. Lens locked in place with tamper-resistant stainless steel Torx® with center pin fasteners and sealed with closed cell gaskets.

END CAPS: Marine grade die-cast aluminum. Three styles available: Flat, Rounded and Reveal. Conduit and "Wiremold" ready knockouts visible only from interior of end cap (Flat and Rounded styles only).

SOCKETS: Shock-resistant sockets with internal locking collar to ensure positive lamp retention.

HARDWARE: Stainless steel, tamper-resistant Torx fasteners secure lens in housing body's lens channel (four on 24", 36", and 48" housings; eight on 72" and 96" housings).

ELECTRICAL: LED: Available 3500K, 4000K and 5000K color temperatures, 82 CRI, 120-277VAC, 50/60Hz electrical input with serviceable high power factor electronic, constant-current driver (<20% THD, >0.95 PF). Standard 0-10V dimming with 1-100% range, maximum driver source of 500 µA. LE: Class P ballasts. Fluorescent electronic 120/277/347 and dual voltage ballasts high power factor.

INSTALLATION: Standard four-point (24" housing), six-point (36" and 48" housing) and twelve-point (72" and 96" housing) mounting required for Peace of Mind Guarantee®. LED product ambient temperature is -30°C to 25°C, unless otherwise noted.

PHOTOMETRICS: Photometry tested to the IESNA LM-79-08 standard by an ILAC/ISO17025 accredited laboratory. For additional photometric information, go to www.kenall.com.

WARRANTY: Limited ten (10) year warranty for LED Lamps.

LISTINGS: UL and CUL listed for Wet Location – covered ceiling mount. UL certified IP64 in compliance with IEC 60598 – ceiling mount. Corner, horizontal wall and pendant mount installation – damp location only. ADA compliant. Product listed on the Designlights Consortium® Qualified Products List. Check the latest version [here](#) for listed configuration details.



MLHA8 48 F MW PP 45L35K DCC DV LEL

LEMONWOOD K-8 RECONSTRUCCION
5EM

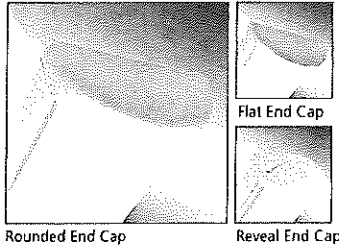

ORDERING INFORMATION (Ex: MLHA8-48-F-MB-PP-45L40K-DCC-DV-FS-9500)

| Model | Length | End Cap | Finish | Lens | Lamp Qty | Lamp Type | Ballast/Driver Type | Circuit Qty | Voltage | Options | Accessories |
|--------------|-----------|----------|-----------|-----------|----------|---------------|---------------------|-------------|-----------|------------|-------------|
| MLHA8 | 48 | F | MW | PP | | 45L35K | DCC | | DV | LEL | |

| | | | |
|--|--|--|--|
| <p>Length</p> <p>24 2'</p> <p>36 3'</p> <p>48 4'</p> <p>72 Two 3' (factory connected)</p> <p>96 Two 4' (factory connected)</p> <p>End Caps</p> <p>F Flat</p> <p>R Rounded</p> <p>RV Reveal</p> <p>Finish</p> <p>LG Light Gray</p> <p>MB Matte Black</p> <p>MW Matte White</p> <p>CC Custom Color (Consult Factory)</p> <p>Lens</p> <p>CP Clear Polycarbonate</p> <p>PP Pearlescent Polycarbonate</p> <p>Lamp Quantity (Cross Section) (n/a with LED)</p> <p>1 One</p> <p>2 Two</p> <p>3 Three (T8 or T5 only)</p> | <p>Lamp Type</p> <p>2' Lengths</p> <p>25L35K 25 Watt 3500K LED</p> <p>25L40K 25 Watt 4000K LED</p> <p>25L50K 25 Watt 5000K LED</p> <p>14 F14T5 (rapid start only)</p> <p>17 F17T8</p> <p>24 F24T5HO (rapid start only)</p> <p>3' Lengths</p> <p>21 F21T5 (rapid start only)</p> <p>25 F25T8</p> <p>39 F39T5HO (rapid start only)</p> <p>4' Lengths</p> <p>45L35K 45 Watt 3500K LED</p> <p>45L40K 45 Watt 4000K LED</p> <p>45L50K 45 Watt 5000K LED</p> <p>67L35K 67 Watt 3500K LED</p> <p>67L40K 67 Watt 4000K LED</p> <p>67L50K 67 Watt 5000K LED</p> <p>90L35K 90 Watt 3500K LED</p> <p>90L40K 90 Watt 4000K LED</p> <p>90L50K 90 Watt 5000K LED</p> <p>28 F28T5 (rapid start only)</p> <p>32 F32T8</p> <p>54 F54T5HO (rapid start only)</p> <p>54A F54T5HO amalgam (rapid start only)</p> <p>Ballast/Driver Type</p> <p>IS Instant Start Electronic <10% THD (T8)</p> <p>RS Rapid Start Electronic <10% THD (T8, T5, T5HO)</p> <p>SB Specified Ballast</p> <p>DCC Dimming Constant Current (LED)</p> | <p>Circuit Quantity (n/a with LED)</p> <p>1 One</p> <p>21 Two (2 Ballast minimum)</p> <p>Voltage</p> <p>120 120 Volts</p> <p>277 277 Volts</p> <p>347 347 Volts (Consult Factory)</p> <p>DV 120-277 Volts</p> <p>Options</p> <p>EL 500 Minimum Lumen Battery Pack (90 Minutes; 32°F Starting Temp)</p> <p>PEL 1100 Minimum Lumen Battery Pack (90 Minutes; 32°F Starting Temp)</p> <p>LEL LED Emergency Battery Backup (4' only) (45L max, 32°F minimum operating temperature)</p> <p>CDF Captive Diffuser Fasteners</p> <p>DL Damp Location (Interior use NO gasketing)</p> <p>FS Single Fuse & Holder (one per circuit)</p> <p>NAT Natatorium Environment Option</p> <p>PH Phillips Head Fasteners</p> <p>PM Pendant Mount (stems by others; damp only)</p> <p>TN Twin Tube Night Light – 577/9 watts (120V only)</p> <p>UC Uplight Component (Pendant Mount only; stems by others; damp only)</p> | <p>Accessories</p> <p>CMB Corner Mount Bracket (Must be ordered with DL Option)</p> <p>9500 Torx® Screwdriver</p> <p>D-0552 Torx Driver Bit (Required for CMB Option)</p> <p>† n/a on 2' T5/T5HO or 3' T5HO fixtures with EL, PEL or TN options</p> <p>▲ n/a with 347V</p> <p>▼ 2' Fixtures have minimum 350-450 lumen battery pack</p> <p>■ n/a on 2' fixtures</p> <p>§ n/a with 3 lamps</p> <p>• n/a with LED Lamp Type</p> <p>‡ PM and CMB not available in conjunction</p> <p style="font-size: 1.2em; font-weight: bold;">3500K LAMPS INCLUDED SEPARATELY</p> |
|--|--|--|--|



www.kenall.com

P: 800-4-Kenall

F: 262-891-9701

10200 55th Street Kenosha, Wisconsin 53144

When you see this image, you will know the Kenall product shown or described is designed and manufactured in the USA with components purchased from US suppliers, and meets the Buy American requirements under the ARRA. Kenall has not determined the origin of its domestically purchased components or the subcomponents thereof. May be covered by patents found at www.kenall.com/patents. Content of specification sheets is subject to change; please consult www.kenall.com for current product details. © 2015 Kenall Mfg. Co. All rights reserved.

MILLENNIUM STRETCH™

MLHA8 SERIES

PERFORMANCE

| Length | Lamp Type | Initial Delivered Lumens | | Input Power (W) | Drive Current (mA) | Estd. L70 LED Life (Hrs) |
|--------|-----------|--------------------------|-----------------|-----------------|--------------------|--------------------------|
| | | @ 25°C | Efficacy (lm/W) | | | |
| 2' | 25L35K | 2316 | 93 | 25 | 94 | 80,000 |
| | 25L40K | 2469 | 99 | 25 | 94 | 80,000 |
| | 25L50K | 2568 | 103 | 25 | 94 | 80,000 |
| 4' | 45L35K | 4632 | 95 | 50 | 94 | 80,000 |
| | 45L40K | 4938 | 101 | 50 | 94 | 80,000 |
| | 45L50K | 5136 | 103 | 50 | 94 | 80,000 |
| | 67L35K | 6640 | 89 | 74 | 66 | 80,000 |
| | 67L40K | 7078 | 95 | 74 | 66 | 80,000 |
| | 67L50K | 7362 | 99 | 74 | 66 | 80,000 |
| | 90L35K | 8445 | 84 | 100 | 94 | 60,000 |
| | 90L40K | 9003 | 90 | 100 | 94 | 60,000 |
| 90L50K | 9363 | 93 | 100 | 94 | 60,000 | |

Information above is valid for the recommended Type PP lens type and is subject to change without notice. Visit www.kenall.com for IES files and additional information.

Model: MLHA8-48-F-MW-PP-45L40K-DCC-DV

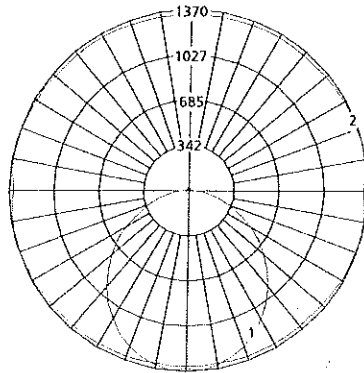

Maximum Candela = 1370 Located At Horizontal Angle = 15, Vertical Angle = 5

- 1 - Vertical Plane Through Horizontal Angles (15-195) (Through Max. Cd.)
- 2 - Horizontal Cone Through Vertical Angle (5) (Through Max. Cd.)

DIMENSIONAL DATA

CROSS SECTION/DETAILS

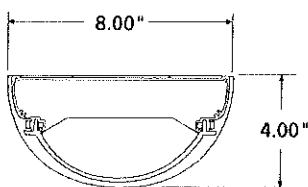

MOUNTING HOLES

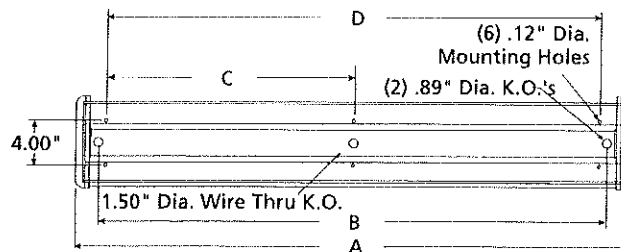

CORNER MOUNT BRACKET

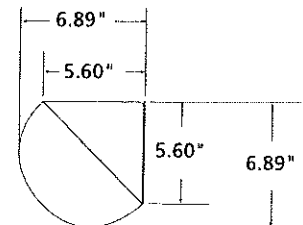

Nominal Two Foot Fixture Legend

| LMP End Cap | A | B | C | D |
|-------------|--------|--------|-----|--------|
| T8 R | 26.524 | 22.312 | N/A | 21.000 |
| T8 F | 25.308 | 22.312 | N/A | 21.000 |
| T8 RV | 28.632 | 22.312 | N/A | 21.000 |
| T5 R | 24.940 | 20.728 | N/A | 20.875 |
| T5 F | 23.724 | 20.728 | N/A | 20.875 |
| T5 RV | 27.048 | 20.728 | N/A | 20.875 |

Nominal Three Foot Fixture Legend

| LMP End Cap | A | B | C | D |
|-------------|--------|--------|--------|--------|
| T8 R | 38.524 | 34.312 | 16.500 | 33.000 |
| T8 F | 34.312 | 34.312 | 16.500 | 33.000 |
| T8 RV | 40.632 | 34.312 | 16.500 | 33.000 |
| T5 R | 36.751 | 32.540 | 16.344 | 32.688 |
| T5 F | 35.535 | 32.540 | 16.344 | 32.688 |
| T5 RV | 38.859 | 32.540 | 16.344 | 32.688 |

Nominal Four Foot Fixture Legend

| LMP End Cap | A | B | C | D |
|-------------|--------|--------|--------|--------|
| T8/LED R | 50.524 | 46.312 | 22.500 | 45.000 |
| T8/LED F | 49.308 | 46.312 | 22.500 | 45.000 |
| T8/LED RV | 52.632 | 46.312 | 22.500 | 45.000 |
| T5 R | 48.562 | 44.350 | 22.250 | 44.500 |
| T5 F | 47.346 | 44.350 | 22.250 | 44.500 |
| T5 RV | 50.670 | 44.350 | 22.250 | 44.500 |



www.kenall.com

P: 800-4-Kenall

F: 262-891-9701

10200 55th Street Kenosha, Wisconsin 53144

When you see this image, you will know the Kenall product shown or described is designed and manufactured in the USA with components purchased from US suppliers, and meets the Buy American requirements under the ARRA. Kenall has not determined the origin of its domestically purchased components or the subcomponents thereof. May be covered by patents found at www.kenall.com/patents. Content of specification sheets is subject to change; please consult www.kenall.com for current product details. © 2015 Kenall Mfg. Co. All rights reserved.



January 4, 2017

Oxnard School District
 1051 South A Street
 Oxnard, CA, 93030

Attn: Ms. Marlene Hickle, CFW Inc.

Subject: Swinerton Builders Job 16055106 - Lemonwood K-8 School LLB
 PCI No. 0079-1 Add wood casework throughout the project per submittal markups. We are proceeding per Lisa Cline's direction

Dear Ms. Hickle,

We request a Change Order to our contract for the following:

Add wood casework throughout the project per submittal markups. We are proceeding per Lisa Cline's direction

| Phase | Category | Description | Subcontractor | Quote |
|--------|----------|--|------------------------|------------------|
| 064100 | 71140 | Modify architectural wood casework per submittal comments and owners direction | STOLO CABINETS, INC. | 13,810.00 |
| | | | Subtotal | 13,810.00 |
| 007480 | 71160 | Subguard | 1.15% | 158.82 |
| 007410 | 71160 | Builders Risk | 0.6% | 83.81 |
| 007420 | 71160 | General Insurance | 1.15% | 160.64 |
| 007510 | 71160 | P&P Bond | 1% | 138.10 |
| 991000 | 79999 | Change Order Fee | 15% | 2,131.99 |
| | | | Markup Subtotal | 2,673.36 |
| | | | PCI Total | 16,483.36 |

CS.

TOTAL AMOUNT OF THIS CHANGE ORDER REQUEST: **16,483.36.**

Please NOTE:

- » The incorporation of this revision in to the contractual scope of work may have an impact on our schedule, which is yet to be finalized. Once determined, the job schedule will be adjusted accordingly to show the effect of this revision on the final project completion date..
- » The terms (cost and schedule impact) of this change order request are subject to review and a requote if not accepted within days of its issuance.
- » This request does not include additional cost or delay due to late approval.

X We **HAVE** proceeded with this revised work per your instructions. Please issue a change order.

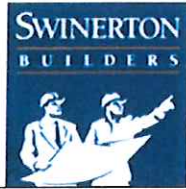

Upon acceptance of this change order request, a formal change order will be issued. Acceptance also acknowledges that Swinerton Builders has proceeded with the above change in scope.

If you have any questions or comments pertaining to this matter, please contact the undersigned.

Sincerely,
Swinerton Builders

Bill Gray
PM

Date: 01/04/2017

Quotation accepted by:
Oxnard School District

By: _____

Date: _____



CONTRACT CHANGE ORDER 02

DATE: October 12,2016
JOB NAME: Lemonwood K-8 ES

TO: Swinerton Builders
ATTN: Nalani Scanlon

Stolo Cabinets, Inc. proposes to furnish the materials and services as listed below. All inclusions, exclusions, and terms and conditions of the original bid remain in effect and any new change(s) will be listed below.

Changes per: Red line Shop Drawings

1. Sheet E5,Area 3-108,(Add) Laminate Plastic Low Wall
2. Sheet E7,Area 3-111,(Delete)(3)Brkt,(Add)(3) 102 cab.,(Add)(1)254 cab.
3. Sheet E8,Area 3-113,(Delete) (1) Brkt.,(Add) (1) 254 cab.
4. Sheet E9,Area 3-115,(Delete) Countertop,(Delete)(3) 302 cab.,(Add)(3) 102 cab.,(Add)(1) Filler,(Add)(1) Countertop,(Add) (3) 302 cab.
5. Sheet E10,Area 3-120,(Add)(1) 102 cab.
6. Sheet E11,Area 3-123,(Add) (3) grommets
7. Sheet E13,Area 3-129,(Add) Laminate Plastic Low Wall
8. Sheet E14,Area 3-130,Delete)(1) 302 cab.,(Add)(1) 102 cab.,(Add)(1) 155ADA cab.,(Add)(1)Filler,(Add)(1) 302 cab.
9. Sheet E15,Area 3-132,(Delete) 302 cab.,(Add)(1) 102 cab.,(Add)(1) 155ADA cab.,(Add)(1)Filler,(Add)(1) 302 cab.

1. THE ABOVE CHANGE WILL INCREASE THE CONTRACT AMOUNT BY **\$ 11,228.00**
2. TIME IMPACT: YES NO
3. WE ARE **PROCEEDING**. PLEASE ISSUE A CHANGE ORDER FOR THE AMOUNT LISTED ABOVE OR SIGN AND RETURN A COPY OF THIS DOCUMENT. THIS QUOTE IS GOOD FOR 30 DAYS.

Steve Johnson
Project Manager

David Fish
Prepared By

ALTHOUGH THE REQUIREMENTS OF A WRITTEN CHANGE ORDER AND NOTICE OF A CLAIM FOR ADDITIONAL COMPENSATION ARE NOT BEING STRICTLY OBSERVED, WE EXPECT AN ADJUSTMENT OF THE CONTRACT PRICE TO COMPENSATE FOR THE WORK DESCRIBED ABOVE. THIS WORK HAS BEEN OR IS BEING PERFORMED BY OUR FIRM TO ACCOMMODATE THE OWNER AND GENERAL CONTRACTOR AND FACILITATE COMPLETION OF THE PROJECT WITHOUT PREJUDICE TO ANY LEGAL OR EQUITABLE RIGHT OF REMEDY TO WHICH WE MAY BE ENTITLED. THE ABOVE DESCRIBED CHANGES ARE ACCEPTED AND STOLO CABINETS IS AUTHORIZED TO PROCEED. YOUR SIGNATURE AUTHORIZES BILLING AND PAYMENT FOR THE ABOVE WORK.

General Contractor/Authorized Representative

Date



CONTRACT CHANGE ORDER 03

DATE: December 13,2016
JOB NAME: Lemonwood ES

TO: Swinerton Builders
ATTN: Bill Gray

Stolo Cabinets, Inc. proposes to furnish the materials and services as listed below. All inclusions, exclusions, and terms and conditions of the original bid remain in effect and any new change(s) will be listed below.

1. Sheet E7,RM 3-111, Add (1) Plastic Laminate Leg
2. Sheet E8,RM 3-113, Add (2) Plastic Laminate Upper Cabinets
3. Sheet E19, RM 4-107, Add (2) Plastic Laminate Base Cabinets
4. Sheet E19, RM 4-107, Deduct (2) Metal Brackets
5. Sheet E19, RM 4-115, Add (2) Plastic Laminate Base Cabinets
6. Sheet E19, RM 4-115, Deduct (2) Metal Brackets

1. THE ABOVE CHANGE WILL **INCREASE** THE CONTRACT AMOUNT BY **\$ 2,582.00**
2. TIME IMPACT: YES NO
3. WE ARE **PROCEEDING**. PLEASE ISSUE A CHANGE ORDER FOR THE AMOUNT LISTED ABOVE OR SIGN AND RETURN A COPY OF THIS DOCUMENT. THIS QUOTE IS GOOD FOR 30 DAYS.

Steve Johnson
Project Manager

David R. Fish
Prepared By

ALTHOUGH THE REQUIREMENTS OF A WRITTEN CHANGE ORDER AND NOTICE OF A CLAIM FOR ADDITIONAL COMPENSATION ARE NOT BEING STRICTLY OBSERVED, WE EXPECT AN ADJUSTMENT OF THE CONTRACT PRICE TO COMPENSATE FOR THE WORK DESCRIBED ABOVE. THIS WORK HAS BEEN OR IS BEING PERFORMED BY OUR FIRM TO ACCOMMODATE THE OWNER AND GENERAL CONTRACTOR AND FACILITATE COMPLETION OF THE PROJECT WITHOUT PREJUDICE TO ANY LEGAL OR EQUITABLE RIGHT OF REMEDY TO WHICH WE MAY BE ENTITLED. THE ABOVE DESCRIBED CHANGES ARE ACCEPTED AND STOLO CABINETS IS AUTHORIZED TO PROCEED. YOUR SIGNATURE AUTHORIZES BILLING AND PAYMENT FOR THE ABOVE WORK.

General Contractor/Authorized Representative

Date



STOLO CABINETS

Since 1953

| Lemonwood ES | | | | CHANGES PER REDLINE CORRECTIONS | | | |
|---------------------------------------|----------|-----|-----------|---------------------------------|------------|-----------|----------------|
| LEMONWOOD ES SCOR 3 | | | | 12/7/2016 | | | |
| ITEM | COMMENTS | UOM | ORIG. QTY | NEW QTY | DIFFERENCE | UNIT COST | TOTAL |
| BLDG #3 RM 3-111 PLASTIC LEG | | EA | 0 | 1.00 | 1.00 | \$ 95.00 | \$ 95.00 |
| BLDG #3 RM 3-113 PLASTIC LAM CASEWORK | | EA | 0 | 2.00 | 2.00 | \$ 285.00 | \$ 570.00 |
| BLDG #4 4-107 PLASTIC LAM CASEWORK | | EA | 0 | 2.00 | 2.00 | \$ 320.00 | \$ 640.00 |
| BLDG #4 4-107 OMIT METAL BRKT | | EA | 2 | 0.00 | -2.00 | \$ 25.00 | \$ (50.00) |
| 3LDG #4 4-115 PLASTIC LAM CASEWORK | | EA | 0 | 2.00 | 2.00 | \$ 320.00 | \$ 640.00 |
| BLDG #4 4-115 OMIT METAL BRKT | | EA | 2 | 0.00 | -2.00 | \$ 25.00 | \$ (50.00) |
| SHOP DRAWINGS | | HRS | 0 | 8.00 | 8.00 | \$ 50.00 | \$ 400.00 |
| SUB-TOTAL | | | | | | | \$2,245 |
| 15% P & O | | | | | | | \$337 |
| TOTAL | | | | | | | \$2,582 |

CONSTRUCTION SERVICES AGREEMENT #15-198

This Construction Services Agreement (hereinafter referred to as the "Agreement") is entered into this 2nd day of March, 2016, by and between the Oxnard School District, a California school district organized and existing under the laws of the State of California (hereinafter referred to as the "District") and Swinerton Builders which is a contractor licensed by the State of California, with its principal place of business at 865 S. Figueroa St., Suite 3000, Los Angeles, CA 90017 (hereinafter referred to as "Contractor").

WHEREAS, the District operates Lemonwood K-8 School, located at 2200 Carnegie Court Oxnard, California 93033 (hereinafter referred to as the "School Facility"); and

WHEREAS, the District desires to construct and modernize facilities and improvements (as more fully described below) at those portions of the School Facility identified in the Site Lease, as defined in Section 1G below (the "Site"); and

WHEREAS, the District has determined that it is in its best interests to pursue the improvements to the School Facility through the lease-leaseback method of project delivery pursuant to California Education Code §17406 which permits the governing board of the District, without advertising for bids, to lease to Contractor property owned by the District if the instrument by which property is leased requires the lessee to construct, or provide for the construction, on the leased property, of a facility for the use of the District during the term of the lease, and provides that title to that facility shall vest in the District at the expiration of the lease; and

WHEREAS, the District desires to finance a portion of the improvements utilizing the lease/leaseback methodology; and

WHEREAS, the District has conducted an RFQ process by which it selected Contractor; and

WHEREAS, the District intends to undertake work to improve the School Facility, the scope of which is generally described in **Exhibit A** attached hereto and incorporated by reference herein; and

WHEREAS, in connection with the approval of this Agreement, the District will enter into a site lease with Contractor, under which it will lease to Contractor the Site in order for Contractor to construct the Project as described in the Scope of Work set forth generally in **Exhibit A** (hereinafter referred to as the "Scope of Work"); and

WHEREAS, assuming that the District and Contractor can agree on the terms, including the price, for the additional scope of work, the District and Contractor anticipate that the scope of the Project may be amended to include additional work; and

WHEREAS, Contractor will lease the Site back to the District pursuant to a sublease agreement, under which the District will be required to make payments to Contractor for the use and occupancy of the Site, including the Project (hereinafter the "Financing"); and

WHEREAS, Contractor represents that it is sufficiently experienced in the construction of the type of facility and type of work sought by the District and is willing to perform said work for lease and the Financing to the District, all as more fully set forth herein; and

WHEREAS, at the expiration of the Site Lease, title to the Site and the improvements thereon will vest with the District;

NOW, THEREFORE, in consideration of the covenants hereinafter contained, the District and Contractor agree as follows:

SECTION 1. DEFINITIONS

- A. **Construction.** The term "Construction" as used in this Agreement includes all labor and services necessary for the construction of the Project, and all materials, equipment, tools, supplies and incidentals incorporated or to be incorporated in such construction as fully described in the Scope of Work set forth in **Exhibit A** attached hereto. Unless otherwise expressly stipulated, Contractor shall perform all work and provide and pay for all materials, labor tools and equipment, including, but not limited to, light, water, and power, necessary for the proper execution and completion of the Project shown on the drawings and described in the specifications developed pursuant to this Agreement.
- B. **Construction Documents.** The term "Construction Documents" means the final drawings, profiles, cross sections, design development drawings, construction drawings, and supplemental drawings based on the plans and specifications developed for the Project pursuant to the Scope of Work set forth in **Exhibit A** attached hereto, including any reference specifications or reproductions prepared by the architect hired by the District (the "Architect") and specifications approved by the District, the Division of the State Architect ("DSA"), and the local agencies having jurisdiction or other regulatory agencies whose approval may be required, which show or describe the location, character, dimensions or details for the Project and specifications for construction thereof.
- C. **Contract Documents.** The term "Contract Documents" as used in this Agreement refers to those documents which form the entire agreement by and between the District and Contractor. The Contract Documents consist of this Agreement, including the exhibits and attachments hereto, the Site Lease, including the exhibits and attachments thereto, the Sublease, including the exhibits and attachments thereto, the Project Manual including the General Conditions thereto, as amended,

which is incorporated herein (the "General Conditions"), and the Construction Documents. The term "Contract Documents" shall include all modifications and addenda thereto.

- D. **Guaranteed Maximum Price.** The term "Guaranteed Maximum Price" or "GMP" as used in this Agreement means the Guaranteed Maximum Price established pursuant to Section 5 of this Agreement to be used to calculate the Tenant Improvement Payments and the Sublease Payments to be paid by the District to Contractor pursuant to the Sublease, subject only to any adjustments for Extra Work/Modifications as provided in Section 10 of this Agreement.
- E. **Project.** The term "Project" shall mean the improvements and facilities to be constructed and installed by Contractor at the School Facility which will result in complete and fully operational facilities as more fully set forth on **Exhibit A** attached hereto.
- F. **Project Manual.** The term "Project Manual" shall mean the compilation of the Specification sections including Division 0, Procurement and Contracting Requirements, Division 1 General Requirements, and technical specifications Division 2 through 33 prepared by the Architect and approved by the District, the DSA, or other regulatory agencies which show or describe the location, character, dimensions or details for the Project, which shall be delivered to Contractor upon execution of this Agreement.
- G. **Site.** The term "Site" as used in this Agreement shall mean those certain parcels of real property and improvements thereon (if any) more particularly described in **Exhibit A** to the Site Lease.
- H. **Site Lease.** The term "Site Lease" as used in this Agreement shall mean the certain Site Lease dated of even date herein between the District and Contractor, together with any duly authorized and executed amendment(s) thereto, pursuant to which the District leases the Site to Contractor.
- I. **Specifications.** The term "Specifications" shall mean those numbered specifications set forth in the Project Manual which shall accompany this Agreement and which are incorporated by reference herein. Individual Specifications may be referred to by their specification number as set forth in the Project Manual.
- J. **Subcontractor.** As used in this Agreement, the term "Subcontractor" means any person or entity, including trade contractors, who have a contract with Contractor to perform any of the Construction.
- K. **Sublease.** The term "Sublease" as used in this Agreement shall mean the certain Sublease dated of even date herein between the District and Contractor, together

with any duly authorized and executed amendment(s) thereto, pursuant to which the District subleases the Site from Contractor.

L. **Sublease Payments.** The term "Sublease Payments" as used in this Agreement shall mean the payments made by the District to Contractor pursuant to Section 6 of the Sublease.

M. **Tenant Improvement Payments.** The term "Tenant Improvement Payments" as used in this Agreement shall mean the payments made by the District to Contractor pursuant to Section 6 of the Sublease.

SECTION 2. CONTRACTOR'S DUTIES AND STATUS

Contractor covenants with the District to furnish reasonable skill and judgment in constructing the Project. Contractor agrees to furnish efficient business administration and superintendence and to furnish at all times an adequate supply of professionals, workers, and materials and to perform the work appropriately, expeditiously, economically, and consistent with the Contract Documents.

SECTION 3. ADDITIONAL SERVICES

If the District requests Contractor to perform additional services not described in this Agreement, Contractor shall provide a cost estimate and a written description of the additional work necessary to complete such additional services. The cost for such additional services shall be negotiated and agreed upon in writing in advance of Contractor performing or contracting for such additional services, and such cost shall be used to adjust the GMP established pursuant to Section 5 hereof. In the absence of a written agreement, the District will not compensate Contractor for additional services, will not adjust the GMP for such additional services, and Contractor will not be required to perform them. It is understood and agreed that if Contractor performs any services that it claims are additional services without receiving prior written approval from the District Board of Education, Contractor shall not be paid for such claimed additional services and the GMP will not be adjusted. Nothing in this Agreement shall be construed as limiting the valuation of such additional services and amount that the GMP will be adjusted for such additional services, should a written agreement for such services be executed by the parties. Notwithstanding the foregoing, Contractor shall not be entitled to compensation, nor will the GMP be adjusted, for additional services required as a result of Contractor's acts, errors or omissions.

SECTION 4. OWNERSHIP OF PLANS AND DOCUMENTS

All original field notes, written reports, drawings, specifications, Construction Documents, and other documents, produced or developed for the Project are the property of the District, regardless of whether the Project is constructed, and shall be furnished to the District. Such documents are not to be used by Contractor or by the Subcontractors on other work nor shall

Contractor nor the Subcontractors claim any right to such documents. This shall not deprive Contractor from retaining electronic data or other reproducible copies of the Construction Documents or the right to reuse information contained in them in the normal course of Contractor's professional activities.

SECTION 5. ESTABLISHMENT OF GUARANTEED MAXIMUM PRICE

The "GMP" for the Project shall be Twenty-Nine Million, Five Hundred Seventy-Five Thousand, Eight Hundred Ninety-Seven Dollars and Ninety-One Cents (\$29,575,897.91). The GMP consists of (1) Sublease Tenant Improvement Payments in the amount of Twenty -Five Million, Four Hundred Eight Thousand One Hundred Eight-Eight Dollars (\$25,408,188.91) and, (2) a Contractor Contingency in the amount of Seven Hundred Forty-Seven Thousand, Seven Hundred and Nine Dollars and No Cents (\$747,709.00), and, (3) Sublease Payments in the amount of \$90,000.00 per month not to exceed a total lease value of \$3,420,000.00 pursuant to terms and payment schedule as set forth in the Sublease.

The GMP is based upon the plans and specifications existing at the time this Agreement is entered into between Contractor and the District, and more fully described and referenced in the Scope of Work set forth in **Exhibit A** attached hereto. Contractor shall assume the risk of cost overruns which were not foreseeable at the time this Agreement is entered into and the GMP determined, except for undocumented events of the type set forth in Section 19 hereof, work mandated by an outside agency after issuance of Construction Documents that could not have been reasonably foreseen from review of the Contract Documents, or costs arising from undocumented geotechnical issues. Contractor acknowledges that (i) Contractor has conducted a site inspection and is familiar with the site conditions based on records, studies and visible conditions relating to construction and labor and (ii) Contractor has reviewed the Contract Documents and is familiar with the contents thereof. District directed changes to the scope of the Project not contemplated in the Scope of Work shall be deemed Extra Work/Modifications pursuant to the procedures set forth in Section 10 of this Agreement. The GMP shall include, but not be limited to, increases in labor and materials. The GMP has been used to calculate the Tenant Improvement Payments and the Sublease Payments to be paid by the District to Contractor pursuant to the Sublease. The GMP includes the cost of all labor, materials, equipment, general conditions, overhead, profit and a Contractor Contingency as indicated above.

The Contractor Contingency is for the purpose of covering the cost of very specific issues that may arise during construction and it may be used only upon the written agreement of the Contractor, the architect of record, and the District. The Contractor Contingency is to be used only to pay Contractor for the following enumerated reasons: (1) additional costs resulting from discrepancies in the bid buy-out process; (2) conflicts, discrepancies or errors in the Construction Documents; (3) work required by the Inspector of Record or any governmental agency involved in the permitting or approval/certification process that is not otherwise shown in the Construction Documents; and (4) any other items of cost agreed to in writing by the Contractor and District to be included in the Contractor Contingency. The Contractor

Contingency shall not be used for costs incurred as a result of Contractor's acts, errors or omissions.

Contractor shall be responsible for tracking expenditures of the Contractor Contingency and shall provide periodic written updates to the District as directed. Contractor shall be entitled to retain unused Contractor Contingency up to a maximum of \$150,000; unused Contractor Contingency over \$150,000 and unused Allowances at Project completion shall reduce the GMP and will result in an adjustment of the Tenant Improvement Payments and possibly the Sublease Payments.

The District shall at all times have the right to reduce the scope of the Project. If the District reduces the scope of the Project, the GMP shall be reduced commensurate with the reduced Scope of Work pursuant to the provisions of Section 10, below, and will result in an adjustment of the Tenant Improvement Payments and, if applicable, the Sublease Payments.

SECTION 6. NOTICE TO PROCEED WITH CONSTRUCTION

Upon receipt of an approved GMP, the District shall issue a notice to Contractor to proceed with the Construction of the Project. In the event that a Notice to Proceed with Construction is not issued for the Project, the Site Lease and the Sublease shall terminate upon written notice from the District to Contractor that a Notice of Proceed will not be issued.

SECTION 7. SAVINGS

If Contractor realizes a savings on one aspect of the Project, such savings shall be tracked and Contractor shall provide periodic written updates of such savings. Such savings shall be added to the Contractor Contingency and the use of such savings shall be as set forth in Section 5. However, if such savings are not so utilized, the amount of such savings shall reduce the GMP and will result in an adjustment of the Tenant Improvement Payments and, if applicable, the Sublease Payments.

SECTION 8. SELECTION OF SUBCONTRACTORS

In the interest of minimizing the expenditure of funds for the construction of the Project, Contractor agrees to select Subcontractors who are appropriately licensed by the State of California for each trade component of the Project in a manner that fosters competition. Contractor agrees that it will either solicit bids from potential subcontractors pursuant to the competitive bid procedures set forth in the California Public Contract Code, including specifically Public Contract Code section 20110, et seq., or that it will utilize an informal bidding process established by Contractor which also incorporates competitive bid procedures. Regardless of the method Contractor employs, Contractor will make a good faith effort to contact and utilize DVBE contractors and suppliers in securing bids for performance of the Project in accordance with the procedures set forth in Section 1.77 of the General Conditions. In the event that Contractor chooses to select Subcontractors pursuant to an informal bidding

process, Contractor shall ensure that it receives at least three competitive quotes from potential subcontractors for each trade component of the Project, unless the parties agree otherwise on a trade-by-trade basis. The District reserves the right to oversee the bidding process. Contractor shall inform all bidders that the District will not be a party to any contracts for construction services executed by Contractor and selected bidders. Contractor shall submit a listing of proposed subcontractors to the District for the District's review. In no case will Contractor award any sub-contracts until the District has concurred in the scope and price of the sub-contracted services. In addition, Contractor shall provide the District with full documentation regarding the bids or competitive quotes received by Contractor. In no event shall such documentation be redacted or obliterated. In the event Contractor does not comply with this provision, the District may terminate this Agreement in accordance with the provisions of the General Conditions. Subcontractors awarded contracts by Contractor shall be afforded all the rights and protections of listed subcontractors under the provisions of the Subletting and Subcontracting Fair Practices Act (Public Contract Code Section 4100, et seq.).

SECTION 9. CONSTRUCTION SCOPE OF WORK

- A. Prior to commencing Construction, Contractor shall comply with the initial schedule requirements set forth in the General Conditions.
- B. Contractor shall complete the Construction pursuant to the Construction Documents as amended subject to any additional DSA or other regulatory approvals as may be required, performing all work set forth in the Scope of Work, and shall make reasonable efforts in scheduling to prevent disruption to classes.
- C. Contractor shall be responsible for complying with all applicable building codes, including without limitation mechanical codes, electrical codes, plumbing codes and fire codes, each of the latest edition, required by the regulatory agencies and for arranging and overseeing all necessary inspections and tests including inspections by the DSA or regulatory agencies, permits and occupancy permits, and ensuring compliance with any Federal and State laws, including, but not limited to, safety procedures and requirements, and construction employee training programs which cover among other items, hazardous chemicals and materials.
- D. Contractor shall establish procedures for the protection of all existing structures, equipment, utilities, and other existing improvements, both on-site and off-site. Contractor assumes all risk of loss of vandalism, theft of property or other property damage ("Vandalism") which occurs at a site at which Contractor is undertaking construction of the Project. Contractor assumes all risk of loss which occurs at a site at which Contractor is undertaking construction of the Project from causes due to negligence or misconduct by Contractor, its officers, employees, subcontractors, licensees and invitees. Contractor shall replace District property damaged by such Vandalism or theft or compensate the District for such loss, including payment of out

of pocket expenses such as insurance deductibles the District might incur under such circumstances.

- E. Contractor shall develop a mutually agreed upon program with the District to abate and minimize noise, dust, and disruption to normal activities at the existing facilities at the School Facility, including procedures to control on-site noise, dust, and pollution during construction.
- F. The District shall cause the appropriate professionals to stamp and sign, as required, the original Construction Documents or parts thereof and coordinate the Project's design with all utilities.
- G. Contractor shall, for the benefit of the Subcontractors, attend pre-construction orientation conferences in conjunction with the Architect to set forth the various reporting procedures and site rules prior to the commencement of actual construction. Contractor shall also attend construction and progress meetings with District representatives and other interested parties, as requested by the District, to discuss such matters as procedures, progress problems and scheduling. Contractor shall prepare and promptly distribute official minutes of such meetings to all parties in attendance, including without limitation the District, the Architect and the District Inspector of Record.
- H. Contractor shall incorporate approved changes as they occur, and develop cash flow reports and forecasts for submittal to the District as requested. Contractor shall provide regular monitoring of the approved estimates for Construction costs, showing actual costs for activities in progress, and estimates for uncompleted tasks. Contractor shall maintain cost accounting records on authorized additional services or work performed under unit costs, additional work performed on the basis of actual costs of labor and materials, and for other work requiring accounting records.
- I. Contractor shall record the progress of the Project and shall submit monthly written progress reports to the District and the Architect including information on the entire Project, showing percentages of completion and the number and amounts of proposed Extra Work/Modifications and their effect on the construction costs as of the date of each respective report.
- J. Contractor shall keep a log containing a record of weather, Subcontractors, work on the site, number of workers, work accomplished, problems encountered, and other similar relevant data as the District may require. Contractor shall make the log available to the District, the Architect, and the District's project manager. The District shall be promptly advised on all anticipated delays in the Project.

- K. The District shall bear the cost for the DSA Inspector, soils testing, DSA or other regulatory agency fees, and special testing required in the construction of the Project. If additional review or permits become necessary for reasons not due to Contractor's fault or because of DSA or regulatory agency requirements or regulations implemented after the date the Final GMP is established and not reasonably anticipated at the time the Final GMP is established, Contractor may seek additional compensation for the cost of that review as an additional cost. In the alternative, the District may pay such costs directly.

SECTION 10. EXTRA WORK/MODIFICATIONS

- A. The District may prescribe or approve additional work or a modification of requirements or of methods of performing the Construction which differ from the work or requirements set forth in the Construction Documents ("Extra Work/Modifications"); and for such purposes the District may at any time during the life of this Agreement, by written order, make such changes as it shall find necessary in the design, line, grade, form, location, dimensions, plan, or material of any part of the work or equipment specified in this Agreement or in the Construction Documents, or in the quantity or character of the work or equipment to be furnished. In the event conditions develop which, in the opinion of Contractor, makes strict compliance with the specifications impractical, Contractor shall notify the District of the need for Extra Work/Modifications by placing the matter on the agenda of regularly scheduled construction meetings with the District for discussion as soon as practicable after the need for the Extra Work/Modifications is determined. Additionally, Contractor shall submit to the District for its consideration and approval or disapproval, a written request for Extra Work/Modifications before such work is performed. If the District approves the request in writing, the costs of the Extra Work/Modification shall be added to or deducted from the GMP or the Scope of Work shall be modified to complete the Project within the GMP, as applicable. Any adjustments to the GMP will result in an adjustment of the Tenant Improvement Payments and, if applicable, the Sublease Payments.

Contractor has proposed a GMP that is based on the Construction

Documents. Contractor, prior to proposing the GMP, was retained by the Owner to perform a comprehensive constructability review, value engineering and project cost estimating. In performing the constructability review, while Contractor's review was done in its role as Contractor, and not design professional, if Contractor discovered any errors, omissions, ambiguities, inconsistencies and other construction issues, Contractor brought such matters to the attention of Owner. Contractor recognizes that it shall not be entitled to an addition to the GMP for additional work related to issues of constructability, or for incidental work that could reasonably be inferred from the Construction Documents, or for any errors or omissions it discovered, or should have discovered, that it did not bring to the attention of the Owner.

- B. Extra Work/Modifications include work related to unforeseen underground conditions if, and only if, such conditions are not visible or identified on plans, reports or other documents available to Contractor. Extra Work/Modifications do not include underground conditions that are identified on plans, reports or other documents available to Contractor but are in a location different than is set forth on such plans, reports or other documents available to Contractor. It should be noted, however, that the District has advised and provided Contractor with information regarding the shallow water table and recent projects experience with encountering water when digging. Contractor has included in its calculation of the GMP an amount to mitigate for encountering water when completing the scope of work contemplated herein.
- C. Should Contractor claim that any instruction, request, drawing, specification, action, condition, omission, default or other situation (i) obligates the District to increase the GMP; or (ii) obligates the District to grant an extension of time for the completion of this Agreement; or (iii) constitutes a waiver of any provision in this Agreement, CONTRACTOR SHALL NOTIFY THE DISTRICT, IN WRITING, OF SUCH CLAIM AS SOON AS POSSIBLE, BUT IN NO EVENT WITHIN MORE THAN TEN (10) DAYS FROM THE DATE CONTRACTOR HAS ACTUAL OR CONSTRUCTIVE NOTICE OF THE CLAIM. CONTRACTOR SHALL ALSO PROVIDE THE DISTRICT WITH SUFFICIENT WRITTEN DOCUMENTATION SUPPORTING THE FACTUAL BASIS OF THE CLAIM including items used in valuing said claim. Contractor shall be required to certify under penalty of perjury the validity and accuracy of any claims submitted. Contractor's failure to notify the District within such ten (10) day period shall be deemed a waiver and relinquishment of the claim against the District.
- D. Expenses of reconstruction and/or costs to replace and/or repair damaged materials and supplies, provided that Contractor is not fully compensated for such expenses and/or costs by insurance or otherwise, shall be included in an increase to the GMP if said expenses are the result of the negligent acts or omissions of the District, or its principals, agents, servants, or employees.

SECTION 11. NOT USED

SECTION 12. PERSONNEL ASSIGNMENT

- A. Contractor shall assign Steven Augustine as Project Manager/Superintendent for the Project. So long as Steven Augustine remains in the employ of Contractor, such person shall not be changed or substituted from the Project, or cease to be fully committed to the Project except as provided in this Section. In the event Contractor deems it necessary, Contractor shall replace the manager and/or the superintendent for the Project with a replacement with like qualifications and experience, subject to

the prior written consent of the District, which consent shall not be unreasonably withheld. Any violation of the terms of paragraph A of this Section 12 shall entitle the District to terminate this Agreement for breach, pursuant to the provisions of the General Conditions.

- B. Notwithstanding the foregoing provisions of paragraph A of Section 12, above, if any manager and/or superintendent proves not to be satisfactory to the District, upon written notice from the District to Contractor, such person(s) shall be promptly replaced by a person who is acceptable to the District in accordance with the following procedures: Within five (5) business days after receipt of a notice from the District requesting replacement of any manager and/or superintendent or discovery by Contractor that any manager and/or superintendent is leaving their employ, as the case may be, Contractor shall provide the District with the name of an acceptable replacement/substitution together with such information as the District may reasonably request about such replacement/substitution. The replacement/substitution shall commence work on the Project no later than five (5) business days following the District's approval of such replacement, which approval shall not be unreasonably withheld. If the District and Contractor cannot agree as to the replacement/substitution, the District shall be entitled to terminate this Agreement for breach pursuant to the provisions of the General Conditions.

SECTION 13. BONDING REQUIREMENTS

Contractor shall fully comply with the requirements set forth in Section 6.9 of the General Conditions.

SECTION 14. PAYMENTS TO CONTRACTOR

- A. Contractor shall finance the cost of construction of the Project which costs shall not exceed the GMP, which shall not be adjusted except as otherwise provided in this Agreement. The District shall pay Contractor Tenant Improvement Payments and Sublease Payments pursuant to the terms and conditions of Section 6 of the Sublease. In the event of a dispute between the District and Contractor, the District may withhold from the Tenant Improvement Payments and the Sublease Payments an amount not to exceed one hundred fifty percent (150%) of the disputed amount.
- B. This Agreement is subject to the provisions of California Public Contract Code Sections 7107, 7201 and 20104.50 as they may from time to time be amended.
- C. For purposes of this Agreement, the acceptance by the District means acceptance made only by an action of the governing body of the District in session. Acceptance by Contractor of the final Tenant Improvement Payment or the Sublease Payment, as the case may be, shall constitute a waiver of all claims against the District related to those amounts.

SECTION 15. CONTRACTOR'S CONTINUING RESPONSIBILITY

Neither the final payment nor any provision in the Contract Documents shall relieve Contractor of responsibility for faulty materials or workmanship incorporated in the Project or for any failure to comply with the requirements of the Contract Documents.

SECTION 16. INSURANCE

Contractor shall provide, during the life of this Agreement, the types and amounts of insurance set forth in Article 6 of the General Conditions, which are incorporated by reference herein.

SECTION 17. USE OF PREMISES

Contractor shall confine operations at the Site to areas permitted by law, ordinances, permits and the Construction Documents and shall not unreasonably encumber the Site or existing School Facilities at the Site with any materials or equipment. Contractor shall not load or permit any part of the work to be loaded with a weight so as to endanger the safety of persons or property at the Site.

SECTION 18. SITE REPRESENTATIONS

The District warrants and represents that the District has, and will continue to retain at all times during the course of construction, legal title to the Site and that said land is properly subdivided and zoned so as to permit the construction and use of said Site with respect to the Project. The District further warrants and represents that title to said land is free of any easements, conditions, limitation, special permits, variances, agreements or restrictions which would prevent, limit or otherwise restrict the construction or use of said Site pursuant to this Agreement. Reference is made to the fact that the District has provided information on the Site to Contractor. Such information shall not relieve Contractor of its responsibility; and the interpretation of such data regarding the Site, as disclosed by any borings or other preliminary investigations, is not warranted or guaranteed, either expressly or implicitly, by the District. Contractor shall be responsible for having ascertained pertinent local conditions such as location, accessibility and general character of the Site and for having satisfied itself as to the conditions under which the work is to be performed. No claim for any allowances because of Contractor's error or negligence in acquainting itself with the conditions at the Site will be recognized.

SECTION 19. HAZARDOUS WASTE AND UNKNOWN PHYSICAL CONDITIONS

Contractor shall comply with the District's Hazardous Materials Procedures and Requirements as set forth herein.

- A. If the District has identified the presence of hazardous materials on or in proximity to the Site (the "Pre-existing Hazardous Materials"), Contractor shall review all information provided by the District that characterizes the Pre-existing Hazardous Materials and shall take the actions approved by DTSC and issued by the District necessary to address the Pre-existing Hazardous Materials in the performance of the work. Contractor shall conduct the work based on this information issued at the time contract documents are executed. Contractor shall immediately communicate, in writing, any variances from available information to the District.
- B. The District will retain an additional independent environmental consultant to perform the investigation, inspection, testing, assessment, sampling and analysis necessary to prepare and recommend a remediation plan for the Pre-existing Hazardous Materials for the District's approval (the "Remediation Plan").
- C. The District will retain title to all Pre-existing Hazardous Materials encountered during the work. This does not include hazardous material generated by Contractor, including but not limited to used motor oils, lubricants, cleaners, etc. Contractor shall dispose of such hazardous waste in accordance with the provisions of the Contract Documents, as well as local, State and Federal laws and regulations. The District will be shown as the hazardous waste generator and will sign all hazardous waste shipment manifests for non-Contractor generated hazardous waste. Nothing contained within these Contract Documents shall be construed or interpreted as requiring Contractor to assume the status of owner or generator of hazardous waste substances for non-Contractor generated hazardous wastes.
- D. Except as otherwise provided herein, it is the responsibility of Contractor to obtain governmental approvals relating to Hazardous Materials Management, including Federal and State surface water and groundwater discharge permits and permits for recycling and reuse of hazardous materials for all work noted in the contract documents. Contractor shall be responsible for coordinating compliance with such governmental approvals and applicable governmental rules with the District's hazardous materials consultant, including those governing the preparation of waste profiles, waste manifests, and bills of lading. If Contractor encounters hazardous materials, it shall immediately notify the District in writing. The District, Consultant and Contractor shall jointly establish the plan for disposition and actions to be taken with respect to the hazardous materials, subject to final written approval by the District.
- E. If, during construction, Contractor encounters materials, conditions, waste, contaminated groundwater or substances, not identified in the District's assessment report, that Contractor reasonably suspects are hazardous materials, Contractor shall stop the affected portion of the work, secure the area, promptly notify the District, and take reasonable measures to mitigate the impact of such work stoppage. The District

shall retain the services of an environmental consultant to perform investigation, inspection, testing, assessment, sampling and analysis of the suspect materials, conditions, waste, groundwater or substances.

- (1) Found Not to be Hazardous Materials. If the environmental consultant determines that the materials, conditions, waste, contaminated groundwater or substances do not constitute hazardous materials, Contractor shall recommence the suspended work.
- (2) Found to be Hazardous Materials. If the environmental consultant determines that the materials, conditions, waste, contaminated groundwater or substances constitute hazardous materials and such hazardous materials require remediation and disposal, then the District, Consultant and Contractor shall jointly establish the plan for disposition and actions to be taken with respect to the hazardous materials, subject to final written approval by the District. All such costs shall be the responsibility of the District.

F. Exacerbation of Pre-Existing Hazardous Materials.

If during construction Contractor encounters pre-existing environmental conditions that it knew or should have known involve hazardous materials (the "Point of Discovery") (which encounters may include an unavoidable release or releases of hazardous materials) then Contractor must immediately stop the affected portion of the work. If Contractor fails to immediately stop the affected portion of the work after the Point of Discovery, then Contractor is solely responsible for any resultant Exacerbation Cost. "Exacerbate," in all its forms, means the worsening effects of Contractor's failure to stop the affected portion of work after the Point of Discovery. "Exacerbation Cost" means the differential between (i) the actual increase in the cost of remediation and delays to the Project attributable to pre-existing environmental conditions involving hazardous substances, and (ii) the cost thereof or delays thereto had Contractor immediately stopped the affected portion of the work after the Point of Discovery. The standard of "should have known" applies to Contractor's supervisory personnel, whether or not on the Site. Contractor's supervisory personnel must have had the hazardous material training required by applicable OSHA and CalOSHA rules or regulations.

SECTION 20. INDEPENDENT CONTRACTOR

- A. Contractor is retained as an independent contractor and is not employed by the District. No employee or agent of Contractor shall become, or be considered to be, an employee of the District for any purpose. It is agreed that the District is interested only in the results obtained from service under this Agreement and that Contractor shall perform as an independent contractor with sole control of the manner and

means of performing the services required under this Agreement. Contractor shall complete this Agreement according to its own methods of work which shall be in the exclusive charge and control of Contractor and which shall not be subject to control or supervision by the District except as to results of the work. It is expressly understood and agreed that Contractor and its employees shall in no event be entitled to any benefits to which the District employees are entitled, including, but not limited to, overtime, retirement benefits, insurance, vacation, worker's compensation benefits, sick or injury leave or other benefits.

- B. Contractor shall be responsible for all salaries, payments, and benefits for all of its officers, agents, and employees in performing services pursuant to this Agreement.

SECTION 21. ACCOUNTING RECORDS

Contractor, and all Subcontractors, shall check all materials, equipment and labor entering into the work and shall keep or cause to be kept such full and detailed accounts as may be necessary for proper financial management under this Agreement, including true and complete books, records and accounts of all financial transactions in the course of their activities and operations related to the Project. These documents include sales slips, invoices, payrolls, personnel records, requests for Subcontractor payment, and other data relating to all matters covered by the Contract Documents (the "Data"). The Data shall be maintained for ten (10) years from the latest expiration of the term (as such may be extended) of any of the Contract Documents. Contractor shall use its best efforts to cause its Subcontractors to keep or cause to be kept true and complete books, records and accounts of all financial transactions in the course of its activities and operations related to the Project. Upon completion of the Project, Contractor shall provide the District with one (1) complete copy of the Data.

The District, at its own costs, shall have the right to review and audit, upon reasonable notice, the books and records of Contractor and any Subcontractors concerning any monies associated with the Project.

SECTION 22. PERSONAL LIABILITY

Neither the trustees, officers, employees, or agents of District, the District's representative, or Architect shall be personally responsible for any liability arising under the Contract Documents.

SECTION 23. AGREEMENT MODIFICATIONS

No waiver, alteration or modification of any of the provisions of this Agreement shall be binding upon either the District or Contractor unless the same shall be in writing and signed by both the District and Contractor.

SECTION 24. NOTICES

Any notices or filings required to be given or made under this Agreement shall be served, given or made in writing upon the District or Contractor, as the case may be, by personal delivery or registered mail (with a copy sent via fax or regular mail) to the respective addresses given below or at such other address as such party may provide in accordance with the provisions herein. Any change in the addresses noted herein shall not be binding upon the other party unless preceded by no less than thirty (30) days prior written notice.

If to Contractor:

Swinerton Builders
865 S. Figueroa Street
Suite 3000
Los Angeles, CA 90017

Attn: Bonnie Martin

If to the District:

Oxnard School District
1051 South A Street
Oxnard, California 93030

Attn: Dr. Cesar Morales, Superintendent

With a copy to Nitasha Sawhney,
Garcia, Hernandez, Sawhney & Bermudez LLP
1330 Broadway, Suite 1701
Oakland, CA 94612

And with an additional copy to Yuri Calderon,
Caldwell Flores Winters, Inc.
6425 Christie Ave., Suite 270
Emeryville, CA 94608

Notices under this Agreement shall be deemed to have been given, and shall be effective upon actual receipt by the other parties, or, if mailed, upon the earlier of the fifth (5th) day after mailing or actual receipt by the other party.

SECTION 25. ASSIGNMENT

Neither party to this Agreement shall assign this Agreement or sublet it as a whole without the written consent of the other, nor shall Contractor assign any monies due or to become due to it hereunder without the prior written consent of the District.

SECTION 26. PROVISIONS REQUIRED BY LAW

Each and every provision of law and clause required to be inserted in these Contract Documents shall be deemed to be inserted herein and the Contract Documents shall be read and enforced as though it were included herein, and if through mistake or otherwise any such provision is not inserted or is not inserted correctly, then upon application of either party the Contract Documents shall forthwith be physically amended to make such insertion or correction.

SECTION 27. HEADINGS

The headings in this Agreement are inserted only as a matter of convenience and reference and are not meant to define, limit or describe the scope or intent of the Contract Documents or in any way to affect the terms and provisions set forth herein.

SECTION 28. APPLICABLE LAW

This Agreement shall be governed by and construed in accordance with the laws of the State of California. The parties irrevocably agree that any action, suit or proceeding by or among the District and Contractor shall be brought in whichever of the Superior Courts of the State of California, Ventura County, or the Federal Court for the Central District of California in Los Angeles, California, has subject matter jurisdiction over the dispute and waive any objection that they may now or hereafter have regarding the choice of forum whether on personal jurisdiction, venue, forum non conveniens or on any other ground.

SECTION 29. SUCCESSION OF RIGHTS AND OBLIGATIONS

All rights and obligations under this Agreement shall inure to and be binding upon the successors and assigns of the parties hereto.

SECTION 30. NOTIFICATION OF THIRD PARTY CLAIMS

The District shall provide Contractor with timely notification of the receipt by the District of any third party claim relating to this Agreement, and the District may charge back to Contractor the cost of any such notification.

SECTION 31. SEVERABILITY

If any one or more of the terms, covenants or conditions of this Agreement shall to any extent be declared invalid, unenforceable, void or voidable for any reason whatsoever by a court of competent jurisdiction, the finding or order or decree of which becomes final, none of the remaining terms, provisions, covenants and conditions of the Contract Documents shall be affected thereby, and each provision of the Contract Documents shall be valid and enforceable to the fullest extent permitted by law.

SECTION 32. ENTIRE AGREEMENT

This Construction Services Agreement and the additional Contract Documents as defined in paragraph C of Section 1 herein, including the Site Lease, the Sublease, and the Specifications, drawings, and plans constitute the entire agreement between Contractor and the District. The Contract Documents shall not be amended, altered, changed, modified or terminated without the written consent of both parties hereto, except as otherwise provided in Section 10 hereof.

SECTION 33. EXECUTION IN COUNTERPARTS

This Agreement may be executed in any number of counterparts, each of which shall be an original, but all of which together shall constitute one instrument.

IN WITNESS WHEREOF the parties hereto, intending to be legally bound thereby, have executed this Agreement effective as of the date first above written.

CONTRACTOR

Swinerton Builders

By:  LIA TATEVOSIAN
Title: OPERATIONS MGR
Date: 4/6/16

THE DISTRICT

Oxnard School District,
a California school district

By: 
Title: District Superintendent
Date: April 26, 2016

EXHIBIT A

Scope of Work

The scope of Work for the Lemonwood Reconstruction Project consists of the construction of a new school, including a Kindergarten, Classroom, Administration and Multipurpose Building, as more specifically described in the DSA Approved plans, specifications and Construction Change Directives ("CCDs"). The following construction documents are referenced herein and incorporated into this contract for all purpose to more fully describe the scope of work contemplated and agreed to by the parties:

1. DSA Approved drawings for DSA Application # 03-116026.
2. DSA Approved Project Manual for DSA Application # 03-116026.
3. Addendum 01 dated 11/16/2015 for DSA Application # 03-116026 as issued to Swinerton Builders on 11/16/2015 by SVA Architects.
4. Addendum 02 dated 11/18/2015 for DSA Application # 03-116026 as issued to Swinerton Builders on 11/18/2015 by SVA Architects.
5. Addendum 03 dated 11/30/2015 for DSA Application # 03-116026 as issued to Swinerton Builders on 11/30/2015 SVA Architects.
6. Project Schedule prepared by Contractor and approved by Owner (Attached hereto).
7. Agreed Upon List of Qualifications (Attached hereto).
8. Pre-bid and Post-Bid Value Management Logs (Attached hereto).
9. Lemonwood GMP Qualification Matrix (Attached hereto).

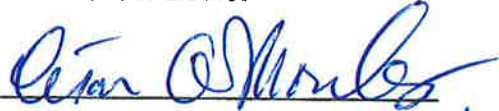
BOARD AGENDA ITEM

Name of Contributor: Dr. Morales/Lisa Cline

Date of Meeting: 3/01/17

STUDY SESSION _____

CLOSED SESSION _____

SECTION A-I: PRELIMINARY _____

SECTION A-II: REPORTS _____

SECTION B: HEARINGS _____

SECTION C: CONSENT AGENDA _____

Agreement Category:

_____ Academic

_____ Enrichment

_____ Special Education

_____ Support Services

_____ Personnel

_____ Legal

X Facilities

SECTION D: ACTION _____

SECTION F: BOARD POLICIES 1st Reading _____ 2nd Reading _____

Consider Approval of Change Order No. 004 to the Construction Services Agreement #15-198 with Swinerton Builders to adjust the completion date and related schedule impact costs for the Lemonwood K-8 School Reconstruction (Morales/Cline/CFW)

The Oxnard School District ("District") Board of Trustees ("Board") Facilities Implementation Plan first adopted in January 2013, calls for the reconstruction of the Lemonwood K-8 School ("Project"). The Project includes the construction of a new school facility at the existing Lemonwood school site. The new facilities will provide for a complete K-8 educational program and will consist of a new combined administration and library building, a new multi-purpose room/gymnasium, a 2-story classroom building, kindergarten classroom building and playfields, hardscape and green space to service the new school.

The original Facilities Implementation Plan called for the construction of the new school beginning in phase 2 of the program in 2017-2018 academic year. CFW, working in consultation with District staff, has accelerated the commencement of construction as a result of thoughtful planning and early access to General Obligation Bond dollars that were not projected to be available until the future.

During grading operations for Classroom Building 1, unidentified, unforeseen underground obstructions were encountered that required their removal and disposal. On June 8, 2016, a section of sixteen-inch (16") diameter concrete pipe was discovered. The pipe was inactive and the discovery did not interfere with the Lemonwood School's daily operation. Efforts were implemented, and an approximate eighty feet (80') of this pipe was removed. During grading operations on July 7, 2016, at a location approximately forty feet (40') south from the location of the sixteen-inch (16") diameter concrete pipe, two (2) sections of two-inch (2") diameter abandoned steel petroleum pipelines were encountered. These pipe lines were also inactive and the discovery did not interfere with the Lemonwood School's daily operation. The Project Environmental Consultant ATC Group Services was contacted to perform observation and testing to assure compliance with the Department of Toxic Substance Control ("DTSC") as required when discovery of previously unknown potential contaminants have been encountered. Full compliance with DTSC requirements has been accomplished.

There were five items addressed in Change Order No. 003: (1) It was determined that the planned provisions for the new power to connect to the existing equipment were not compatible. A transformer is being installed to provide adequate power for the existing ECDC/Preschool building while it continues operations. (2) The portable classroom buildings are currently being used as science classrooms and require temporary water and sewer lines. These were not meant to have said utilities. (3) Submittal review of hardware manufacturers revealed that there was a preference for Schlage over Sargent to maintain district standards. (4) Submittal review of light fixtures established the preference of LED lighting over the specified. (5) District requested wood casework throughout the project in lieu of what was specified.

This recommended agenda item provides for the Board's consideration and approval of Change Order No. 004. The process in attaining DTSC approvals for the previously discovered petroleum pipelines impacted the project's critical path from June 18, 2016 through October 25, 2016. This extended the contractor's general conditions costs due to schedule impacts. After careful consideration, the contractor has established that an additional sixty-eight (68) working days or ninety-five (95) calendar days will be required for the completion of the project.

FISCAL IMPACT

Four Hundred Seventy Thousand Six Hundred Ninety-Five Dollars and Twenty Cents (\$470,695.20) to be paid out of Master Construct and Implementation funds.

RECOMMENDATION

It is the recommendation of the Superintendent, and the Deputy Superintendent, Business and Fiscal Services, in conjunction with Caldwell Flores Winters, Inc., that the Board of Trustees approve Change Order No. 004 to the Construction Services Agreement #15-198 with Swinerton Builders to provide Construction Services related to the Lemonwood Elementary School Reconstruction Project of Measure "R" Program under the Lease-Leaseback delivery method pursuant to Section 17406 of the California Education Code.

ADDITIONAL MATERIAL

Attached: Change Order No. 004, Swinerton Builders (2 Pages)
 Swinerton Builders PCI #0010-3 (13 Pages)
 Construction Services Agreement #15-198, Swinerton Builders (19 Pages)



CHANGE ORDER

Date: 03.01.2016

CHANGE ORDER NO. 004

PROJECT: LEMONWOOD K-8 RECONSTRUCTION
O.S.D. BID No. N/A
O.S.D. Agreement No. 15-198

OWNER: Oxnard School District
 1051 South A Street
 Oxnard, CA. 93030

ARCHITECT SVA Architects, Inc.
 3 MacArthur Place, Suite 850
 Santa Ana, CA 92707

CONTRACTOR:
SWINERTON BUILDERS
 865 South Figueroa St., Suite 3000
 Los Angeles, CA 90017
Attn: Mr. Michael Darquea

Architects Proj. No.: 2013-40121
D.S.A. File No.: 56-22
D.S.A. App. No.: 03-116026

CONFORMANCE WITH CONTRACT DOCUMENTS, PROJECT MANUAL, DRAWINGS AND SPECIFICATION. All Change Order work shall be in strict conformance with the Contract Documents, Project Manual, Drawings, and Specifications as they pertain to work of a similar nature.

| | |
|--|----------------------|
| ORIGINAL CONTRACT SUM..... | \$ 29,575,897.91 |
| NET CHANGE - ALL PREVIOUS CHANGE ORDERS (001-003)..... | \$ 154,105.74 |
| ADJUSTED CONTRACT SUM..... | \$ 29,730,003.65 |
| NET CHANGE - | \$ 470,695.20 |
| Total Change Orders to Date: 004..... | \$ 624,800.94 |
| ADJUSTED CONTRACT SUM THROUGH CHANGE ORDER NO.: 004..... | \$ 30,200,698.85 |
| Anticipated Commencement Date..... | May 4, 2016 |
| Actual Commencement Date: | May 23, 2016 |
| Original Completion Date: | July 04, 2018 |
| Original Contract Time: | 791 Calendar Days |
| Time Extension for all Previous Change Orders: | Zero Days |
| Time Extension for this Change Order: | 95 Days |
| Adjusted Completion Date: | October 26, 2018 |
| Percentage | (2.07%) |

| Item | Description | Unforeseen Condition (UFO) | Additional Scope (AS) | Design Clarification (DC) | Code Requirement |
|------|---|----------------------------|-----------------------|---------------------------|------------------|
| 1. | PCI 0010-3 Delayed start to MPR Building due to DTSC processing approvals | \$470,695.20 | | | |
| 2. | | | | | |
| 3. | | | | | |
| 4. | | | | | |
| 5. | | | | | |
| | Totals | \$470,695.20 | | | |

Total Change Order No. \$ 470,695.20

**NOT VALID UNTIL SIGNED BY THE ARCHITECT, CONTRACTOR AND ASST. SUPT. BUSINESS SERVICES OR PURCHASING DIRECTOR*

APPROVAL (REQUIRED):

ARCHITECT: _____

DATE: _____

CONTRACTOR: _____

DATE: _____

RECOMMENDED FOR APPROVAL:

OSD DSA INSPECTOR: _____

DATE: _____

DEPUTY SUPERINTENDENT BUSINESS AND FISCAL SERVICES:

DATE: _____

APPROVAL (REQUIRED):

BOARD APPROVAL

DATE: _____

DEPUTY SUPT./PURCHASING DIRECTOR: _____

DATE: _____

DSA APPROVAL

DATE: _____



December 29, 2016

Oxnard School District
 1051 South A Street
 Oxnard, CA, 93030

Attn: Mr. Scott Burkett

Subject: Swinerton Builders Job 16055106 - Lemonwood K-8 School LLB
 PCI No. 0010-3 DTSC delay Phase 1A

Dear Mr. Burkett,

We request a Change Order to our contract for the following:

Delayed start to MPR Building due to delayed issuance of DTSC approvals, additional soils testing, and development of soils management plan to work in the Phase 1A area. This PCI includes Swinerton Builders extended general conditions cost due to schedule impacts to the project's critical path from June 18, 2016 through October 25, 2016. Thus resulting in a **Revised Final Project Completion date of October 26, 2018.**

| Phase | Category | Description | Subcontractor | Quote |
|--------|----------|--|------------------------|-------------------|
| 502001 | 71150 | Extended General Condition 95 calendar days @ \$ 4,187.00/day | | 397,765.00 |
| | | | Subtotal | 397,765.00 |
| 007480 | 71160 | Subguard | 1.15% | 4,574.30 |
| 007410 | 71160 | Builders Risk | 0.6% | 2,386.59 |
| 007420 | 71160 | General Insurance | 1.15% | 4,574.30 |
| 991000 | 79999 | Change Order Fee | 15% | 61,395.03 |
| | | | Markup Subtotal | 72,930.21 |
| | | | PCI Total | 470,695.20 |

C.Y.

TOTAL AMOUNT OF THIS CHANGE ORDER REQUEST: 470,695.20

Please NOTE:

- » The incorporation of this revision in to the contractual scope of work has had an impact on our schedule. The job schedule will be adjusted accordingly to show the effect of this revision on the final project completion date. Pursuant to the Impact analysis provided herewith the Revised Project Final Completion will be October 26, 2018.
- » The Direct Cost of the work associated with this impact has been submitted under separate cover. This request only includes Extended Overhead Costs for Swinerton Builders only.
- » The terms (cost and schedule impact) of this change order request are subject to review and a requote if not accepted within days of its issuance.
- » This request does not include additional cost or delay due to late approval.



We **HAVE** proceeded with this revised work per your instructions. Please issue a change order.

Upon acceptance of this change order request, a formal change order will be issued. Acceptance also acknowledges that Swinerton Builders has proceeded with the above change in scope.

If you have any questions or comments pertaining to this matter, please contact the undersigned.

Sincerely,
Swinerton Builders

Quotation accepted by:
Oxnard School District

Bill Gray
PM
Date: 12/29/2016

By: _____
Date: _____



Integrity
Leadership
Passion
Excellence

Date: December 29, 2016

To: Oxnard School District

**Re: Lemonwood Elementary School Reconstruction
Swinerton Job #16055106
Phase 1A and 2 Delay / Time Extension Request**

Dear Mr. Burkett,

Contained herein is a Time Impact Analysis to support our request for additional time to complete the project associated with the delayed construction start of the MPR Building. As the analysis will show, the additional time requested to complete the project was due to the delayed issuance of DTSC approvals, additional soil testing requirements, and the development of a soil management plans. Thus, impacting the start of Phase 1A, Phase 2, and Project Final Completion.

A narrative description of the delay is included in this request, additionally we are pleased to provide the following attachments that contain the data that substantiates our request:

EXHIBIT A - Affected Sequence from Baseline Schedule (B00A)

EXHIBIT B - Comparison of Affected Sequence from Impacted Schedule (X00A) against Baseline Schedule (B00A)

EXHIBIT C - Working Day Exhibit

EXHIBIT D - Calendar Day Exhibit

Time Impact Analysis Narrative

Introduction

The attached schedule sequence from B00A is used as a reflection of the project status immediately prior to the impact, complete with the original durations and logic. A copy of B00A was created and renamed X00A to represent the impacted schedule, with B00A as the baseline. A fragnet (activity network) representing the impact events was then inserted into X00A and linked as a predecessor to the baseline activities:

P1.B1.1100 - Pothole / Vacuum - Water Jet Existing Underground Utilities West

P1.B1.1220 - Excavate Sanitary Sewer Line (South of Bldg. 1)

P1.B1.SU.1040 - Saw cut, Demo, and Dispose of AC Paving

P1.EY.1000 – Survey Equipment Pad Enclosure

P2.1040 – Clear and Grub

P2.1115 - Disassemble Play Equipment

After the fragnet was added to schedule X00A the impacted schedule was recalculated. This caused the Final Completion Milestone to extend beyond the contractual completion date, reflecting an unmitigated completion date. This is demonstrated in the attachment "Comparison of Affected Sequence from Impacted Schedule (X00A) against Baseline Schedule (B00A)".



Duration of the Delay

The delay began on June 18, 2016; the first day that work on the Phase 1A MPR was scheduled to begin (restricted by start of summer break). The delay ultimately ended on October 24th, 2016 once a crew was mobilized after the Phase 1A site was released to complete clearing and grubbing. The actual duration of this delay is sixty-eight (68) working days, or ninety-five (95) calendar days (*reference attached calendar exhibits C & D*).

Impact on Final Completion

The time required to obtain DTSC approval, perform additional soil testing and develop a soil management plan prior to starting any work within the Phase 1A Site directly impacted the project's baseline Final Completion date. The Project's Final Completion, with this delay, is forecast to be October 26, 2018.

Request for Additional Time

Based on our Time Impact Analysis, Swinerton Builders is requesting sixty-eight (68) working days, or ninety-five (95) calendar days be added to our Contract Duration, revising the Contract End date to be October 26, 2018.

Thank you for considering our request for additional time to complete the Project. Please contact me directly if you have any questions or comments about our request.

Sincerely,
Swinerton Builders

David Rennie
Schedule

cc: Bill Gray, Project Manager
Michael Darquea, Project Executive
File

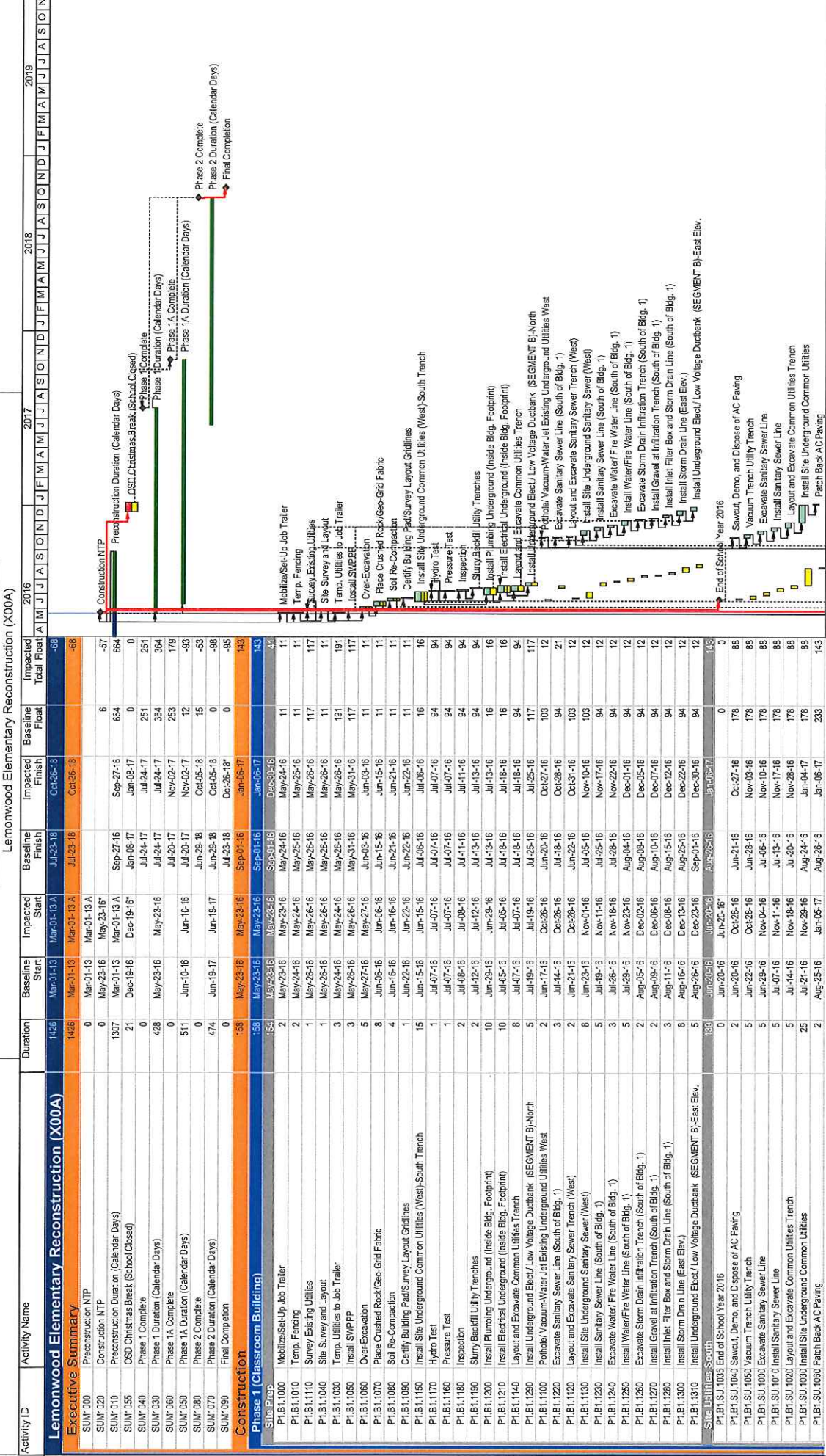

EXHIBIT A



EXHIBIT B

Phase 1A and 2 Delays - Time Impact Analysis



Remaining Level of Effort ■ Critical Remaining Work
 Actual Level of Effort ■ Milestone
 Actual Work ■ Primary Baseline
 Remaining Work ■

Page 1 of 2

IMPACTED SCHEDULE (X00A) COMPARISON TO BASELINE (B00A)

Phase 1A and 2 Delays - Time Impact Analysis

| Activity ID | Activity Name | Duration | Baseline Start | Impacted Start | Baseline Finish | Impacted Finish | Baseline Float | Impacted Total Float | 2016 | 2017 | 2018 | 2019 |
|--------------------------------|---|----------|----------------|----------------|-----------------|-----------------|----------------|----------------------|------|------|------|------|
| Phase 1A (MPR Building) | | | | | | | | | | | | |
| P2.1005 | Phase 1A & 2 Delays | 121 | Jun-10-16 | Jun-10-16 | Aug-16-16 | Dec-01-16 | -68 | -68 | | | | |
| X.A1540 | Delay in Receiving the NFA Letter to Start Phase 1A, Phase 2, and All Related | 88 | Jun-18-16 | Jun-18-16 | Oct-25-16 | | -74 | -74 | | | | |
| X.A1590 | District approves additional soils boring to clarify depth of contaminate | 1 | Oct-10-16* | Oct-10-16* | Oct-10-16 | | -66 | -66 | | | | |
| X.A1670 | District resolves extent of contaminates | 19 | Sep-28-16 | Sep-28-16 | Oct-20-16 | | -74 | -74 | | | | |
| X.A1680 | Swinerton receives additional boring test results | 1 | Oct-21-16 | Oct-21-16 | Oct-21-16 | | -74 | -74 | | | | |
| X.A1790 | Mobilize trade contractor | 1 | Oct-24-16 | Oct-24-16 | Oct-24-16 | | -74 | -74 | | | | |
| X.A1780 | Swinerton begins demolition PH1A | 1 | Oct-25-16 | Oct-25-16 | Oct-25-16 | | -74 | -74 | | | | |
| Site Prep | | | | | | | | | | | | |
| P2.1006 | Beginning of 2016 Summer Break | 0 | Jun-10-16 | Jun-10-16 | Aug-01-16 | Dec-01-16 | 0 | -75 | | | | |
| P2.1007 | Temp. Fencing | 2 | Jun-17-16 | Jun-17-16 | Jun-20-16 | Jun-20-16 | 15 | 15 | | | | |
| P2.1008 | Site Survey and Layout Extent of Demo | 1 | Jun-20-16 | Jun-20-16 | Jun-20-16 | Jun-20-16 | 18 | 18 | | | | |
| P2.1110 | Install SWPPP | 3 | Jun-20-16 | Jun-20-16 | Jun-22-16 | Jun-22-16 | 37 | 37 | | | | |
| P2.0000 | District Salvage & Move Out | 5 | Jun-17-16 | Jun-17-16 | Jun-23-16 | Jun-23-16 | 15 | 15 | | | | |
| P2.2000 | Notify AQMD | 10 | Jun-10-16 | Jun-10-16 | Jun-23-16 | Jun-23-16 | 20 | 20 | | | | |
| P2.1100 | Demo Existing Portables | 3 | Jun-21-16 | Jun-21-16 | Jun-23-16 | Jun-23-16 | 20 | 20 | | | | |
| P2.1120 | Layout Bldg. Over-Excavation Limits | 1 | Jun-24-16 | Jun-24-16 | Jun-24-16 | Jun-24-16 | 20 | 20 | | | | |
| P2.1115 | Disassemble Play Equipment | 3 | Jun-21-16 | Jun-21-16 | Jun-23-16 | Jun-23-16 | 15 | -74 | | | | |
| P2.1040 | Clear and Grub | 3 | Jun-24-16 | Jun-24-16 | Jun-28-16 | Nov-02-16 | 15 | -74 | | | | |
| P2.1050 | Sale-off/Out and Cap Existing Utilities | 3 | Jun-29-16 | Nov-03-16 | Jul-01-16 | Nov-07-16 | 15 | -74 | | | | |
| P2.1130 | Over-Excavation | 5 | Jul-05-16 | Nov-08-16 | Jul-11-16 | Nov-14-16 | 15 | -74 | | | | |
| P2.1140 | Place Crushed Rock/Geo-Grid Fabric | 5 | Jul-12-16 | Nov-15-16 | Jul-18-16 | Nov-21-16 | 15 | -74 | | | | |
| P2.1150 | Soil Re-Compaction | 5 | Aug-09-16 | Nov-22-16 | Aug-15-16 | Nov-30-16* | 0 | -74 | | | | |
| P2.1160 | Certify Building Pref/Survey Layout Gridlines | 1 | Aug-16-16 | Dec-01-16 | Aug-16-16 | Dec-01-16 | 6 | -68 | | | | |

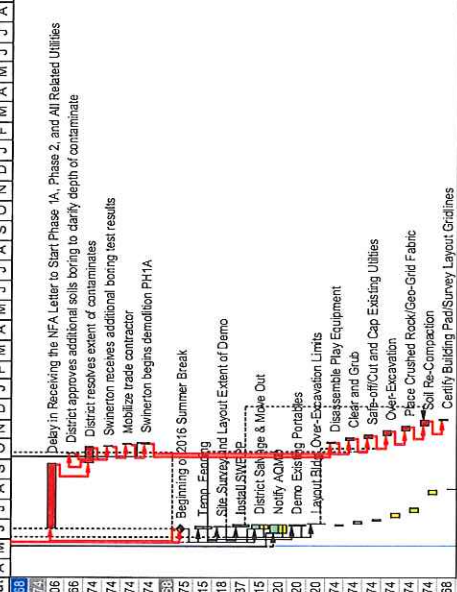

■ Remaining Level of Effort ■ Critical Remaining Work
■ Actual Level of Effort ◆ Milestones
■ Actual Work ■ Primary Baseline
■ Remaining Work



EXHIBIT C

Phase 1A and 2 Delay Working Day Impact to Final Completion

06
23
19
+20
68 Work Days

2018 Calendar

| January 2018 | | | | | | |
|--------------|----|----|----|----|----|-------|
| W | S | M | T | W | T | F S |
| 1 | | 1 | 2 | 3 | 4 | 5 6 |
| 2 | 7 | 8 | 9 | 10 | 11 | 12 13 |
| 3 | 14 | 15 | 16 | 17 | 18 | 19 20 |
| 4 | 21 | 22 | 23 | 24 | 25 | 26 27 |
| 5 | 28 | 29 | 30 | 31 | | |

| February 2018 | | | | | | |
|---------------|----|----|----|----|----|-------|
| W | S | M | T | W | T | F S |
| 5 | | | | | 1 | 2 3 |
| 6 | 4 | 5 | 6 | 7 | 8 | 9 10 |
| 7 | 11 | 12 | 13 | 14 | 15 | 16 17 |
| 8 | 18 | 19 | 20 | 21 | 22 | 23 24 |
| 9 | 25 | 26 | 27 | 28 | | |

| March 2018 | | | | | | |
|------------|----|----|----|----|----|-------|
| W | S | M | T | W | T | F S |
| 9 | | | | | 1 | 2 3 |
| 10 | 4 | 5 | 6 | 7 | 8 | 9 10 |
| 11 | 11 | 12 | 13 | 14 | 15 | 16 17 |
| 12 | 18 | 19 | 20 | 21 | 22 | 23 24 |
| 13 | 25 | 26 | 27 | 28 | 29 | 30 31 |

| April 2018 | | | | | | |
|------------|----|----|----|----|----|-------|
| W | S | M | T | W | T | F S |
| 14 | 1 | 2 | 3 | 4 | 5 | 6 7 |
| 15 | 8 | 9 | 10 | 11 | 12 | 13 14 |
| 16 | 15 | 16 | 17 | 18 | 19 | 20 21 |
| 17 | 22 | 23 | 24 | 25 | 26 | 27 28 |
| 18 | 29 | 30 | | | | |

| May 2018 | | | | | | |
|----------|----|----|----|----|----|-------|
| W | S | M | T | W | T | F S |
| 18 | | 1 | 2 | 3 | 4 | 5 |
| 19 | 6 | 7 | 8 | 9 | 10 | 11 12 |
| 20 | 13 | 14 | 15 | 16 | 17 | 18 19 |
| 21 | 20 | 21 | 22 | 23 | 24 | 25 26 |
| 22 | 27 | 28 | 29 | 30 | 31 | |

| June 2018 | | | | | | |
|-----------|----|----|----|----|----|-------|
| W | S | M | T | W | T | F S |
| 22 | | | | | 1 | 2 |
| 23 | 3 | 4 | 5 | 6 | | |
| 24 | 10 | 11 | 12 | 13 | | |
| 25 | 17 | 18 | 19 | 20 | 21 | 22 23 |
| 26 | 24 | 25 | 26 | 27 | 28 | 29 30 |

| July 2018 | | | | | | |
|-----------|----|----|----|----|----|-------|
| W | S | M | T | W | T | F S |
| 27 | 1 | 2 | 3 | 4 | 5 | 6 7 |
| 28 | 8 | 9 | 10 | 11 | 12 | 13 14 |
| 29 | 15 | 16 | 17 | 18 | 19 | 20 21 |
| 30 | 22 | 23 | 24 | 25 | 26 | 27 28 |
| 31 | 29 | 30 | 31 | | | |

| August 2018 | | | | | | |
|-------------|----|----|----|----|----|-------|
| W | S | M | T | W | T | F S |
| 31 | | 1 | 2 | 3 | 4 | |
| 32 | 5 | 6 | 7 | 8 | 9 | 10 11 |
| 33 | 12 | 13 | 14 | 15 | 16 | 17 18 |
| 34 | 19 | 20 | 21 | 22 | 23 | 24 25 |
| 35 | 26 | 27 | 28 | 29 | 30 | 31 |

| September 2018 | | | | | | |
|----------------|----|----|----|----|----|-------|
| W | S | M | T | W | T | F S |
| 35 | | | | | | 1 |
| 36 | 2 | 3 | 4 | 5 | 6 | 7 8 |
| 37 | 9 | 10 | 11 | 12 | 13 | 14 15 |
| 38 | 16 | 17 | 18 | 19 | 20 | 21 22 |
| 39 | 23 | 24 | 25 | 26 | 27 | 28 29 |
| 40 | 30 | | | | | |

| October 2018 | | | | | | |
|--------------|----|----|----|----|----|-------|
| W | S | M | T | W | T | F S |
| 40 | | 1 | 2 | 3 | 4 | 5 6 |
| 41 | 7 | 8 | 9 | 10 | 11 | 12 13 |
| 42 | 14 | 15 | 16 | 17 | 18 | 19 20 |
| 43 | 21 | 22 | 23 | 24 | 25 | 26 27 |
| 44 | 28 | 29 | 30 | 31 | | |

| November 2018 | | | | | | |
|---------------|----|----|----|----|----|-------|
| W | S | M | T | W | T | F S |
| 44 | | | | | 1 | 2 3 |
| 45 | 4 | 5 | 6 | 7 | 8 | 9 10 |
| 46 | 11 | 12 | 13 | 14 | 15 | 16 17 |
| 47 | 18 | 19 | 20 | 21 | 22 | 23 24 |
| 48 | 25 | 26 | 27 | 28 | 29 | 30 |

| December 2018 | | | | | | |
|---------------|----|----|----|----|----|-------|
| W | S | M | T | W | T | F S |
| 48 | | | | | | 1 |
| 49 | 2 | 3 | 4 | 5 | 6 | 7 8 |
| 50 | 9 | 10 | 11 | 12 | 13 | 14 15 |
| 51 | 16 | 17 | 18 | 19 | 20 | 21 22 |
| 52 | 23 | 24 | 25 | 26 | 27 | 28 29 |
| 1 | 30 | 31 | | | | |



EXHIBIT D

Phase 1A and 2 Delay Calendar Day Impact to Final Completion

08
31
30
+26
95 Calendar Days

2018 Calendar

| January 2018 | | | | | | |
|--------------|----|----|----|----|----|-------|
| W | S | M | T | W | T | F S |
| 1 | | 1 | 2 | 3 | 4 | 5 6 |
| 2 | 7 | 8 | 9 | 10 | 11 | 12 13 |
| 3 | 14 | 15 | 16 | 17 | 18 | 19 20 |
| 4 | 21 | 22 | 23 | 24 | 25 | 26 27 |
| 5 | 28 | 29 | 30 | 31 | | |

| February 2018 | | | | | | |
|---------------|----|----|----|----|----|-------|
| W | S | M | T | W | T | F S |
| 5 | | | | | 1 | 2 3 |
| 6 | 4 | 5 | 6 | 7 | 8 | 9 10 |
| 7 | 11 | 12 | 13 | 14 | 15 | 16 17 |
| 8 | 18 | 19 | 20 | 21 | 22 | 23 24 |
| 9 | 25 | 26 | 27 | 28 | | |

| March 2018 | | | | | | |
|------------|----|----|----|----|----|-------|
| W | S | M | T | W | T | F S |
| 9 | | | | | 1 | 2 3 |
| 10 | 4 | 5 | 6 | 7 | 8 | 9 10 |
| 11 | 11 | 12 | 13 | 14 | 15 | 16 17 |
| 12 | 18 | 19 | 20 | 21 | 22 | 23 24 |
| 13 | 25 | 26 | 27 | 28 | 29 | 30 31 |

| April 2018 | | | | | | |
|------------|----|----|----|----|----|-------|
| W | S | M | T | W | T | F S |
| 14 | 1 | 2 | 3 | 4 | 5 | 6 7 |
| 15 | 8 | 9 | 10 | 11 | 12 | 13 14 |
| 16 | 15 | 16 | 17 | 18 | 19 | 20 21 |
| 17 | 22 | 23 | 24 | 25 | 26 | 27 28 |
| 18 | 29 | 30 | | | | |

| May 2018 | | | | | | |
|----------|----|----|----|----|----|-------|
| W | S | M | T | W | T | F S |
| 18 | | 1 | 2 | 3 | 4 | 5 |
| 19 | 6 | 7 | 8 | 9 | 10 | 11 12 |
| 20 | 13 | 14 | 15 | 16 | 17 | 18 19 |
| 21 | 20 | 21 | 22 | 23 | 24 | 25 26 |
| 22 | 27 | 28 | 29 | 30 | 31 | |

| June 2018 | | | | | | |
|-----------|----|----|----|----|----|-------|
| W | S | M | T | W | T | F S |
| 22 | | | | | 1 | 2 |
| 23 | 3 | 4 | 5 | 6 | | |
| 24 | 10 | 11 | 12 | 13 | | |
| 25 | 17 | 18 | 19 | 20 | 21 | 22 23 |
| 26 | 24 | 25 | 26 | 27 | 28 | 29 30 |

| July 2018 | | | | | | |
|-----------|----|----|----|----|----|-------|
| W | S | M | T | W | T | F S |
| 27 | 1 | 2 | 3 | 4 | 5 | 6 7 |
| 28 | 8 | 9 | 10 | 11 | 12 | 13 14 |
| 29 | 15 | 16 | 17 | 18 | 19 | 20 21 |
| 30 | 22 | 23 | 24 | 25 | 26 | 27 28 |
| 31 | 29 | 30 | 31 | | | |

| August 2018 | | | | | | |
|-------------|----|----|----|----|----|-------|
| W | S | M | T | W | T | F S |
| 31 | | 1 | 2 | 3 | 4 | |
| 32 | 5 | 6 | 7 | 8 | 9 | 10 11 |
| 33 | 12 | 13 | 14 | 15 | 16 | 17 18 |
| 34 | 19 | 20 | 21 | 22 | 23 | 24 25 |
| 35 | 26 | 27 | 28 | 29 | 30 | 31 |

| September 2018 | | | | | | |
|----------------|----|----|----|----|----|-------|
| W | S | M | T | W | T | F S |
| 35 | | | | | 1 | |
| 36 | 2 | 3 | 4 | 5 | 6 | 7 8 |
| 37 | 9 | 10 | 11 | 12 | 13 | 14 15 |
| 38 | 16 | 17 | 18 | 19 | 20 | 21 22 |
| 39 | 23 | 24 | 25 | 26 | 27 | 28 29 |
| 40 | 30 | | | | | |

| October 2018 | | | | | | |
|--------------|----|----|----|----|----|-------|
| W | S | M | T | W | T | F S |
| 40 | | 1 | 2 | 3 | 4 | 5 6 |
| 41 | 7 | 8 | 9 | 10 | 11 | 12 13 |
| 42 | 14 | 15 | 16 | 17 | 18 | 19 20 |
| 43 | 21 | 22 | 23 | 24 | 25 | 26 27 |
| 44 | 28 | 29 | 30 | 31 | | |

| November 2018 | | | | | | |
|---------------|----|----|----|----|----|-------|
| W | S | M | T | W | T | F S |
| 44 | | | | | 1 | 2 3 |
| 45 | 4 | 5 | 6 | 7 | 8 | 9 10 |
| 46 | 11 | 12 | 13 | 14 | 15 | 16 17 |
| 47 | 18 | 19 | 20 | 21 | 22 | 23 24 |
| 48 | 25 | 26 | 27 | 28 | 29 | 30 |

| December 2018 | | | | | | |
|---------------|----|----|----|----|----|-------|
| W | S | M | T | W | T | F S |
| 48 | | | | | | 1 |
| 49 | 2 | 3 | 4 | 5 | 6 | 7 8 |
| 50 | 9 | 10 | 11 | 12 | 13 | 14 15 |
| 51 | 16 | 17 | 18 | 19 | 20 | 21 22 |
| 52 | 23 | 24 | 25 | 26 | 27 | 28 29 |
| 1 | 30 | 31 | | | | |

CONSTRUCTION SERVICES AGREEMENT #15-198

This Construction Services Agreement (hereinafter referred to as the "Agreement") is entered into this 2nd day of March, 2016, by and between the Oxnard School District, a California school district organized and existing under the laws of the State of California (hereinafter referred to as the "District") and Swinerton Builders which is a contractor licensed by the State of California, with its principal place of business at 865 S. Figueroa St., Suite 3000, Los Angeles, CA 90017 (hereinafter referred to as "Contractor").

WHEREAS, the District operates Lemonwood K-8 School, located at 2200 Carnegie Court Oxnard, California 93033 (hereinafter referred to as the "School Facility"); and

WHEREAS, the District desires to construct and modernize facilities and improvements (as more fully described below) at those portions of the School Facility identified in the Site Lease, as defined in Section 1G below (the "Site"); and

WHEREAS, the District has determined that it is in its best interests to pursue the improvements to the School Facility through the lease-leaseback method of project delivery pursuant to California Education Code §17406 which permits the governing board of the District, without advertising for bids, to lease to Contractor property owned by the District if the instrument by which property is leased requires the lessee to construct, or provide for the construction, on the leased property, of a facility for the use of the District during the term of the lease, and provides that title to that facility shall vest in the District at the expiration of the lease; and

WHEREAS, the District desires to finance a portion of the improvements utilizing the lease/leaseback methodology; and

WHEREAS, the District has conducted an RFQ process by which it selected Contractor; and

WHEREAS, the District intends to undertake work to improve the School Facility, the scope of which is generally described in **Exhibit A** attached hereto and incorporated by reference herein; and

WHEREAS, in connection with the approval of this Agreement, the District will enter into a site lease with Contractor, under which it will lease to Contractor the Site in order for Contractor to construct the Project as described in the Scope of Work set forth generally in **Exhibit A** (hereinafter referred to as the "Scope of Work"); and

WHEREAS, assuming that the District and Contractor can agree on the terms, including the price, for the additional scope of work, the District and Contractor anticipate that the scope of the Project may be amended to include additional work; and

WHEREAS, Contractor will lease the Site back to the District pursuant to a sublease agreement, under which the District will be required to make payments to Contractor for the use and occupancy of the Site, including the Project (hereinafter the "Financing"); and

WHEREAS, Contractor represents that it is sufficiently experienced in the construction of the type of facility and type of work sought by the District and is willing to perform said work for lease and the Financing to the District, all as more fully set forth herein; and

WHEREAS, at the expiration of the Site Lease, title to the Site and the improvements thereon will vest with the District;

NOW, THEREFORE, in consideration of the covenants hereinafter contained, the District and Contractor agree as follows:

SECTION 1. DEFINITIONS

- A. **Construction.** The term "Construction" as used in this Agreement includes all labor and services necessary for the construction of the Project, and all materials, equipment, tools, supplies and incidentals incorporated or to be incorporated in such construction as fully described in the Scope of Work set forth in **Exhibit A** attached hereto. Unless otherwise expressly stipulated, Contractor shall perform all work and provide and pay for all materials, labor tools and equipment, including, but not limited to, light, water, and power, necessary for the proper execution and completion of the Project shown on the drawings and described in the specifications developed pursuant to this Agreement.
- B. **Construction Documents.** The term "Construction Documents" means the final drawings, profiles, cross sections, design development drawings, construction drawings, and supplemental drawings based on the plans and specifications developed for the Project pursuant to the Scope of Work set forth in **Exhibit A** attached hereto, including any reference specifications or reproductions prepared by the architect hired by the District (the "Architect") and specifications approved by the District, the Division of the State Architect ("DSA"), and the local agencies having jurisdiction or other regulatory agencies whose approval may be required, which show or describe the location, character, dimensions or details for the Project and specifications for construction thereof.
- C. **Contract Documents.** The term "Contract Documents" as used in this Agreement refers to those documents which form the entire agreement by and between the District and Contractor. The Contract Documents consist of this Agreement, including the exhibits and attachments hereto, the Site Lease, including the exhibits and attachments thereto, the Sublease, including the exhibits and attachments thereto, the Project Manual including the General Conditions thereto, as amended,

which is incorporated herein (the "General Conditions"), and the Construction Documents. The term "Contract Documents" shall include all modifications and addenda thereto.

- D. **Guaranteed Maximum Price.** The term "Guaranteed Maximum Price" or "GMP" as used in this Agreement means the Guaranteed Maximum Price established pursuant to Section 5 of this Agreement to be used to calculate the Tenant Improvement Payments and the Sublease Payments to be paid by the District to Contractor pursuant to the Sublease, subject only to any adjustments for Extra Work/Modifications as provided in Section 10 of this Agreement.
- E. **Project.** The term "Project" shall mean the improvements and facilities to be constructed and installed by Contractor at the School Facility which will result in complete and fully operational facilities as more fully set forth on **Exhibit A** attached hereto.
- F. **Project Manual.** The term "Project Manual" shall mean the compilation of the Specification sections including Division 0, Procurement and Contracting Requirements, Division 1 General Requirements, and technical specifications Division 2 through 33 prepared by the Architect and approved by the District, the DSA, or other regulatory agencies which show or describe the location, character, dimensions or details for the Project, which shall be delivered to Contractor upon execution of this Agreement.
- G. **Site.** The term "Site" as used in this Agreement shall mean those certain parcels of real property and improvements thereon (if any) more particularly described in **Exhibit A** to the Site Lease.
- H. **Site Lease.** The term "Site Lease" as used in this Agreement shall mean the certain Site Lease dated of even date herein between the District and Contractor, together with any duly authorized and executed amendment(s) thereto, pursuant to which the District leases the Site to Contractor.
- I. **Specifications.** The term "Specifications" shall mean those numbered specifications set forth in the Project Manual which shall accompany this Agreement and which are incorporated by reference herein. Individual Specifications may be referred to by their specification number as set forth in the Project Manual.
- J. **Subcontractor.** As used in this Agreement, the term "Subcontractor" means any person or entity, including trade contractors, who have a contract with Contractor to perform any of the Construction.
- K. **Sublease.** The term "Sublease" as used in this Agreement shall mean the certain Sublease dated of even date herein between the District and Contractor, together

with any duly authorized and executed amendment(s) thereto, pursuant to which the District subleases the Site from Contractor.

L. **Sublease Payments.** The term "Sublease Payments" as used in this Agreement shall mean the payments made by the District to Contractor pursuant to Section 6 of the Sublease.

M. **Tenant Improvement Payments.** The term "Tenant Improvement Payments" as used in this Agreement shall mean the payments made by the District to Contractor pursuant to Section 6 of the Sublease.

SECTION 2. CONTRACTOR'S DUTIES AND STATUS

Contractor covenants with the District to furnish reasonable skill and judgment in constructing the Project. Contractor agrees to furnish efficient business administration and superintendence and to furnish at all times an adequate supply of professionals, workers, and materials and to perform the work appropriately, expeditiously, economically, and consistent with the Contract Documents.

SECTION 3. ADDITIONAL SERVICES

If the District requests Contractor to perform additional services not described in this Agreement, Contractor shall provide a cost estimate and a written description of the additional work necessary to complete such additional services. The cost for such additional services shall be negotiated and agreed upon in writing in advance of Contractor performing or contracting for such additional services, and such cost shall be used to adjust the GMP established pursuant to Section 5 hereof. In the absence of a written agreement, the District will not compensate Contractor for additional services, will not adjust the GMP for such additional services, and Contractor will not be required to perform them. It is understood and agreed that if Contractor performs any services that it claims are additional services without receiving prior written approval from the District Board of Education, Contractor shall not be paid for such claimed additional services and the GMP will not be adjusted. Nothing in this Agreement shall be construed as limiting the valuation of such additional services and amount that the GMP will be adjusted for such additional services, should a written agreement for such services be executed by the parties. Notwithstanding the foregoing, Contractor shall not be entitled to compensation, nor will the GMP be adjusted, for additional services required as a result of Contractor's acts, errors or omissions.

SECTION 4. OWNERSHIP OF PLANS AND DOCUMENTS

All original field notes, written reports, drawings, specifications, Construction Documents, and other documents, produced or developed for the Project are the property of the District, regardless of whether the Project is constructed, and shall be furnished to the District. Such documents are not to be used by Contractor or by the Subcontractors on other work nor shall

Contractor nor the Subcontractors claim any right to such documents. This shall not deprive Contractor from retaining electronic data or other reproducible copies of the Construction Documents or the right to reuse information contained in them in the normal course of Contractor's professional activities.

SECTION 5. ESTABLISHMENT OF GUARANTEED MAXIMUM PRICE

The "GMP" for the Project shall be Twenty-Nine Million, Five Hundred Seventy-Five Thousand, Eight Hundred Ninety-Seven Dollars and Ninety-One Cents (\$29,575,897.91). The GMP consists of (1) Sublease Tenant Improvement Payments in the amount of Twenty -Five Million, Four Hundred Eight Thousand One Hundred Eight-Eight Dollars (\$25,408,188.91) and, (2) a Contractor Contingency in the amount of Seven Hundred Forty-Seven Thousand, Seven Hundred and Nine Dollars and No Cents (\$747,709.00), and, (3) Sublease Payments in the amount of \$90,000.00 per month not to exceed a total lease value of \$3,420,000.00 pursuant to terms and payment schedule as set forth in the Sublease.

The GMP is based upon the plans and specifications existing at the time this Agreement is entered into between Contractor and the District, and more fully described and referenced in the Scope of Work set forth in **Exhibit A** attached hereto. Contractor shall assume the risk of cost overruns which were not foreseeable at the time this Agreement is entered into and the GMP determined, except for undocumented events of the type set forth in Section 19 hereof, work mandated by an outside agency after issuance of Construction Documents that could not have been reasonably foreseen from review of the Contract Documents, or costs arising from undocumented geotechnical issues. Contractor acknowledges that (i) Contractor has conducted a site inspection and is familiar with the site conditions based on records, studies and visible conditions relating to construction and labor and (ii) Contractor has reviewed the Contract Documents and is familiar with the contents thereof. District directed changes to the scope of the Project not contemplated in the Scope of Work shall be deemed Extra Work/Modifications pursuant to the procedures set forth in Section 10 of this Agreement. The GMP shall include, but not be limited to, increases in labor and materials. The GMP has been used to calculate the Tenant Improvement Payments and the Sublease Payments to be paid by the District to Contractor pursuant to the Sublease. The GMP includes the cost of all labor, materials, equipment, general conditions, overhead, profit and a Contractor Contingency as indicated above.

The Contractor Contingency is for the purpose of covering the cost of very specific issues that may arise during construction and it may be used only upon the written agreement of the Contractor, the architect of record, and the District. The Contractor Contingency is to be used only to pay Contractor for the following enumerated reasons: (1) additional costs resulting from discrepancies in the bid buy-out process; (2) conflicts, discrepancies or errors in the Construction Documents; (3) work required by the Inspector of Record or any governmental agency involved in the permitting or approval/certification process that is not otherwise shown in the Construction Documents; and (4) any other items of cost agreed to in writing by the Contractor and District to be included in the Contractor Contingency. The Contractor

Contingency shall not be used for costs incurred as a result of Contractor's acts, errors or omissions.

Contractor shall be responsible for tracking expenditures of the Contractor Contingency and shall provide periodic written updates to the District as directed. Contractor shall be entitled to retain unused Contractor Contingency up to a maximum of \$150,000; unused Contractor Contingency over \$150,000 and unused Allowances at Project completion shall reduce the GMP and will result in an adjustment of the Tenant Improvement Payments and possibly the Sublease Payments.

The District shall at all times have the right to reduce the scope of the Project. If the District reduces the scope of the Project, the GMP shall be reduced commensurate with the reduced Scope of Work pursuant to the provisions of Section 10, below, and will result in an adjustment of the Tenant Improvement Payments and, if applicable, the Sublease Payments.

SECTION 6. NOTICE TO PROCEED WITH CONSTRUCTION

Upon receipt of an approved GMP, the District shall issue a notice to Contractor to proceed with the Construction of the Project. In the event that a Notice to Proceed with Construction is not issued for the Project, the Site Lease and the Sublease shall terminate upon written notice from the District to Contractor that a Notice of Proceed will not be issued.

SECTION 7. SAVINGS

If Contractor realizes a savings on one aspect of the Project, such savings shall be tracked and Contractor shall provide periodic written updates of such savings. Such savings shall be added to the Contractor Contingency and the use of such savings shall be as set forth in Section 5. However, if such savings are not so utilized, the amount of such savings shall reduce the GMP and will result in an adjustment of the Tenant Improvement Payments and, if applicable, the Sublease Payments.

SECTION 8. SELECTION OF SUBCONTRACTORS

In the interest of minimizing the expenditure of funds for the construction of the Project, Contractor agrees to select Subcontractors who are appropriately licensed by the State of California for each trade component of the Project in a manner that fosters competition. Contractor agrees that it will either solicit bids from potential subcontractors pursuant to the competitive bid procedures set forth in the California Public Contract Code, including specifically Public Contract Code section 20110, et seq., or that it will utilize an informal bidding process established by Contractor which also incorporates competitive bid procedures. Regardless of the method Contractor employs, Contractor will make a good faith effort to contact and utilize DVBE contractors and suppliers in securing bids for performance of the Project in accordance with the procedures set forth in Section 1.77 of the General Conditions. In the event that Contractor chooses to select Subcontractors pursuant to an informal bidding

process, Contractor shall ensure that it receives at least three competitive quotes from potential subcontractors for each trade component of the Project, unless the parties agree otherwise on a trade-by-trade basis. The District reserves the right to oversee the bidding process. Contractor shall inform all bidders that the District will not be a party to any contracts for construction services executed by Contractor and selected bidders. Contractor shall submit a listing of proposed subcontractors to the District for the District's review. In no case will Contractor award any sub-contracts until the District has concurred in the scope and price of the sub-contracted services. In addition, Contractor shall provide the District with full documentation regarding the bids or competitive quotes received by Contractor. In no event shall such documentation be redacted or obliterated. In the event Contractor does not comply with this provision, the District may terminate this Agreement in accordance with the provisions of the General Conditions. Subcontractors awarded contracts by Contractor shall be afforded all the rights and protections of listed subcontractors under the provisions of the Subletting and Subcontracting Fair Practices Act (Public Contract Code Section 4100, et seq.).

SECTION 9. CONSTRUCTION SCOPE OF WORK

- A. Prior to commencing Construction, Contractor shall comply with the initial schedule requirements set forth in the General Conditions.
- B. Contractor shall complete the Construction pursuant to the Construction Documents as amended subject to any additional DSA or other regulatory approvals as may be required, performing all work set forth in the Scope of Work, and shall make reasonable efforts in scheduling to prevent disruption to classes.
- C. Contractor shall be responsible for complying with all applicable building codes, including without limitation mechanical codes, electrical codes, plumbing codes and fire codes, each of the latest edition, required by the regulatory agencies and for arranging and overseeing all necessary inspections and tests including inspections by the DSA or regulatory agencies, permits and occupancy permits, and ensuring compliance with any Federal and State laws, including, but not limited to, safety procedures and requirements, and construction employee training programs which cover among other items, hazardous chemicals and materials.
- D. Contractor shall establish procedures for the protection of all existing structures, equipment, utilities, and other existing improvements, both on-site and off-site. Contractor assumes all risk of loss of vandalism, theft of property or other property damage ("Vandalism") which occurs at a site at which Contractor is undertaking construction of the Project. Contractor assumes all risk of loss which occurs at a site at which Contractor is undertaking construction of the Project from causes due to negligence or misconduct by Contractor, its officers, employees, subcontractors, licensees and invitees. Contractor shall replace District property damaged by such Vandalism or theft or compensate the District for such loss, including payment of out

of pocket expenses such as insurance deductibles the District might incur under such circumstances.

- E. Contractor shall develop a mutually agreed upon program with the District to abate and minimize noise, dust, and disruption to normal activities at the existing facilities at the School Facility, including procedures to control on-site noise, dust, and pollution during construction.
- F. The District shall cause the appropriate professionals to stamp and sign, as required, the original Construction Documents or parts thereof and coordinate the Project's design with all utilities.
- G. Contractor shall, for the benefit of the Subcontractors, attend pre-construction orientation conferences in conjunction with the Architect to set forth the various reporting procedures and site rules prior to the commencement of actual construction. Contractor shall also attend construction and progress meetings with District representatives and other interested parties, as requested by the District, to discuss such matters as procedures, progress problems and scheduling. Contractor shall prepare and promptly distribute official minutes of such meetings to all parties in attendance, including without limitation the District, the Architect and the District Inspector of Record.
- H. Contractor shall incorporate approved changes as they occur, and develop cash flow reports and forecasts for submittal to the District as requested. Contractor shall provide regular monitoring of the approved estimates for Construction costs, showing actual costs for activities in progress, and estimates for uncompleted tasks. Contractor shall maintain cost accounting records on authorized additional services or work performed under unit costs, additional work performed on the basis of actual costs of labor and materials, and for other work requiring accounting records.
- I. Contractor shall record the progress of the Project and shall submit monthly written progress reports to the District and the Architect including information on the entire Project, showing percentages of completion and the number and amounts of proposed Extra Work/Modifications and their effect on the construction costs as of the date of each respective report.
- J. Contractor shall keep a log containing a record of weather, Subcontractors, work on the site, number of workers, work accomplished, problems encountered, and other similar relevant data as the District may require. Contractor shall make the log available to the District, the Architect, and the District's project manager. The District shall be promptly advised on all anticipated delays in the Project.

- K. The District shall bear the cost for the DSA Inspector, soils testing, DSA or other regulatory agency fees, and special testing required in the construction of the Project. If additional review or permits become necessary for reasons not due to Contractor's fault or because of DSA or regulatory agency requirements or regulations implemented after the date the Final GMP is established and not reasonably anticipated at the time the Final GMP is established, Contractor may seek additional compensation for the cost of that review as an additional cost. In the alternative, the District may pay such costs directly.

SECTION 10. EXTRA WORK/MODIFICATIONS

- A. The District may prescribe or approve additional work or a modification of requirements or of methods of performing the Construction which differ from the work or requirements set forth in the Construction Documents ("Extra Work/Modifications"); and for such purposes the District may at any time during the life of this Agreement, by written order, make such changes as it shall find necessary in the design, line, grade, form, location, dimensions, plan, or material of any part of the work or equipment specified in this Agreement or in the Construction Documents, or in the quantity or character of the work or equipment to be furnished. In the event conditions develop which, in the opinion of Contractor, makes strict compliance with the specifications impractical, Contractor shall notify the District of the need for Extra Work/Modifications by placing the matter on the agenda of regularly scheduled construction meetings with the District for discussion as soon as practicable after the need for the Extra Work/Modifications is determined. Additionally, Contractor shall submit to the District for its consideration and approval or disapproval, a written request for Extra Work/Modifications before such work is performed. If the District approves the request in writing, the costs of the Extra Work/Modification shall be added to or deducted from the GMP or the Scope of Work shall be modified to complete the Project within the GMP, as applicable. Any adjustments to the GMP will result in an adjustment of the Tenant Improvement Payments and, if applicable, the Sublease Payments.

Contractor has proposed a GMP that is based on the Construction

Documents. Contractor, prior to proposing the GMP, was retained by the Owner to perform a comprehensive constructability review, value engineering and project cost estimating. In performing the constructability review, while Contractor's review was done in its role as Contractor, and not design professional, if Contractor discovered any errors, omissions, ambiguities, inconsistencies and other construction issues, Contractor brought such matters to the attention of Owner. Contractor recognizes that it shall not be entitled to an addition to the GMP for additional work related to issues of constructability, or for incidental work that could reasonably be inferred from the Construction Documents, or for any errors or omissions it discovered, or should have discovered, that it did not bring to the attention of the Owner.

- B. Extra Work/Modifications include work related to unforeseen underground conditions if, and only if, such conditions are not visible or identified on plans, reports or other documents available to Contractor. Extra Work/Modifications do not include underground conditions that are identified on plans, reports or other documents available to Contractor but are in a location different than is set forth on such plans, reports or other documents available to Contractor. It should be noted, however, that the District has advised and provided Contractor with information regarding the shallow water table and recent projects experience with encountering water when digging. Contractor has included in its calculation of the GMP an amount to mitigate for encountering water when completing the scope of work contemplated herein.
- C. Should Contractor claim that any instruction, request, drawing, specification, action, condition, omission, default or other situation (i) obligates the District to increase the GMP; or (ii) obligates the District to grant an extension of time for the completion of this Agreement; or (iii) constitutes a waiver of any provision in this Agreement, CONTRACTOR SHALL NOTIFY THE DISTRICT, IN WRITING, OF SUCH CLAIM AS SOON AS POSSIBLE, BUT IN NO EVENT WITHIN MORE THAN TEN (10) DAYS FROM THE DATE CONTRACTOR HAS ACTUAL OR CONSTRUCTIVE NOTICE OF THE CLAIM. CONTRACTOR SHALL ALSO PROVIDE THE DISTRICT WITH SUFFICIENT WRITTEN DOCUMENTATION SUPPORTING THE FACTUAL BASIS OF THE CLAIM including items used in valuing said claim. Contractor shall be required to certify under penalty of perjury the validity and accuracy of any claims submitted. Contractor's failure to notify the District within such ten (10) day period shall be deemed a waiver and relinquishment of the claim against the District.
- D. Expenses of reconstruction and/or costs to replace and/or repair damaged materials and supplies, provided that Contractor is not fully compensated for such expenses and/or costs by insurance or otherwise, shall be included in an increase to the GMP if said expenses are the result of the negligent acts or omissions of the District, or its principals, agents, servants, or employees.

SECTION 11. NOT USED

SECTION 12. PERSONNEL ASSIGNMENT

- A. Contractor shall assign Steven Augustine as Project Manager/Superintendent for the Project. So long as Steven Augustine remains in the employ of Contractor, such person shall not be changed or substituted from the Project, or cease to be fully committed to the Project except as provided in this Section. In the event Contractor deems it necessary, Contractor shall replace the manager and/or the superintendent for the Project with a replacement with like qualifications and experience, subject to

the prior written consent of the District, which consent shall not be unreasonably withheld. Any violation of the terms of paragraph A of this Section 12 shall entitle the District to terminate this Agreement for breach, pursuant to the provisions of the General Conditions.

- B. Notwithstanding the foregoing provisions of paragraph A of Section 12, above, if any manager and/or superintendent proves not to be satisfactory to the District, upon written notice from the District to Contractor, such person(s) shall be promptly replaced by a person who is acceptable to the District in accordance with the following procedures: Within five (5) business days after receipt of a notice from the District requesting replacement of any manager and/or superintendent or discovery by Contractor that any manager and/or superintendent is leaving their employ, as the case may be, Contractor shall provide the District with the name of an acceptable replacement/substitution together with such information as the District may reasonably request about such replacement/substitution. The replacement/substitution shall commence work on the Project no later than five (5) business days following the District's approval of such replacement, which approval shall not be unreasonably withheld. If the District and Contractor cannot agree as to the replacement/substitution, the District shall be entitled to terminate this Agreement for breach pursuant to the provisions of the General Conditions.

SECTION 13. BONDING REQUIREMENTS

Contractor shall fully comply with the requirements set forth in Section 6.9 of the General Conditions.

SECTION 14. PAYMENTS TO CONTRACTOR

- A. Contractor shall finance the cost of construction of the Project which costs shall not exceed the GMP, which shall not be adjusted except as otherwise provided in this Agreement. The District shall pay Contractor Tenant Improvement Payments and Sublease Payments pursuant to the terms and conditions of Section 6 of the Sublease. In the event of a dispute between the District and Contractor, the District may withhold from the Tenant Improvement Payments and the Sublease Payments an amount not to exceed one hundred fifty percent (150%) of the disputed amount.
- B. This Agreement is subject to the provisions of California Public Contract Code Sections 7107, 7201 and 20104.50 as they may from time to time be amended.
- C. For purposes of this Agreement, the acceptance by the District means acceptance made only by an action of the governing body of the District in session. Acceptance by Contractor of the final Tenant Improvement Payment or the Sublease Payment, as the case may be, shall constitute a waiver of all claims against the District related to those amounts.

SECTION 15. CONTRACTOR'S CONTINUING RESPONSIBILITY

Neither the final payment nor any provision in the Contract Documents shall relieve Contractor of responsibility for faulty materials or workmanship incorporated in the Project or for any failure to comply with the requirements of the Contract Documents.

SECTION 16. INSURANCE

Contractor shall provide, during the life of this Agreement, the types and amounts of insurance set forth in Article 6 of the General Conditions, which are incorporated by reference herein.

SECTION 17. USE OF PREMISES

Contractor shall confine operations at the Site to areas permitted by law, ordinances, permits and the Construction Documents and shall not unreasonably encumber the Site or existing School Facilities at the Site with any materials or equipment. Contractor shall not load or permit any part of the work to be loaded with a weight so as to endanger the safety of persons or property at the Site.

SECTION 18. SITE REPRESENTATIONS

The District warrants and represents that the District has, and will continue to retain at all times during the course of construction, legal title to the Site and that said land is properly subdivided and zoned so as to permit the construction and use of said Site with respect to the Project. The District further warrants and represents that title to said land is free of any easements, conditions, limitation, special permits, variances, agreements or restrictions which would prevent, limit or otherwise restrict the construction or use of said Site pursuant to this Agreement. Reference is made to the fact that the District has provided information on the Site to Contractor. Such information shall not relieve Contractor of its responsibility; and the interpretation of such data regarding the Site, as disclosed by any borings or other preliminary investigations, is not warranted or guaranteed, either expressly or implicitly, by the District. Contractor shall be responsible for having ascertained pertinent local conditions such as location, accessibility and general character of the Site and for having satisfied itself as to the conditions under which the work is to be performed. No claim for any allowances because of Contractor's error or negligence in acquainting itself with the conditions at the Site will be recognized.

SECTION 19. HAZARDOUS WASTE AND UNKNOWN PHYSICAL CONDITIONS

Contractor shall comply with the District's Hazardous Materials Procedures and Requirements as set forth herein.

- A. If the District has identified the presence of hazardous materials on or in proximity to the Site (the "Pre-existing Hazardous Materials"), Contractor shall review all information provided by the District that characterizes the Pre-existing Hazardous Materials and shall take the actions approved by DTSC and issued by the District necessary to address the Pre-existing Hazardous Materials in the performance of the work. Contractor shall conduct the work based on this information issued at the time contract documents are executed. Contractor shall immediately communicate, in writing, any variances from available information to the District.
- B. The District will retain an additional independent environmental consultant to perform the investigation, inspection, testing, assessment, sampling and analysis necessary to prepare and recommend a remediation plan for the Pre-existing Hazardous Materials for the District's approval (the "Remediation Plan").
- C. The District will retain title to all Pre-existing Hazardous Materials encountered during the work. This does not include hazardous material generated by Contractor, including but not limited to used motor oils, lubricants, cleaners, etc. Contractor shall dispose of such hazardous waste in accordance with the provisions of the Contract Documents, as well as local, State and Federal laws and regulations. The District will be shown as the hazardous waste generator and will sign all hazardous waste shipment manifests for non-Contractor generated hazardous waste. Nothing contained within these Contract Documents shall be construed or interpreted as requiring Contractor to assume the status of owner or generator of hazardous waste substances for non-Contractor generated hazardous wastes.
- D. Except as otherwise provided herein, it is the responsibility of Contractor to obtain governmental approvals relating to Hazardous Materials Management, including Federal and State surface water and groundwater discharge permits and permits for recycling and reuse of hazardous materials for all work noted in the contract documents. Contractor shall be responsible for coordinating compliance with such governmental approvals and applicable governmental rules with the District's hazardous materials consultant, including those governing the preparation of waste profiles, waste manifests, and bills of lading. If Contractor encounters hazardous materials, it shall immediately notify the District in writing. The District, Consultant and Contractor shall jointly establish the plan for disposition and actions to be taken with respect to the hazardous materials, subject to final written approval by the District.
- E. If, during construction, Contractor encounters materials, conditions, waste, contaminated groundwater or substances, not identified in the District's assessment report, that Contractor reasonably suspects are hazardous materials, Contractor shall stop the affected portion of the work, secure the area, promptly notify the District, and take reasonable measures to mitigate the impact of such work stoppage. The District

shall retain the services of an environmental consultant to perform investigation, inspection, testing, assessment, sampling and analysis of the suspect materials, conditions, waste, groundwater or substances.

- (1) Found Not to be Hazardous Materials. If the environmental consultant determines that the materials, conditions, waste, contaminated groundwater or substances do not constitute hazardous materials, Contractor shall recommence the suspended work.
- (2) Found to be Hazardous Materials. If the environmental consultant determines that the materials, conditions, waste, contaminated groundwater or substances constitute hazardous materials and such hazardous materials require remediation and disposal, then the District, Consultant and Contractor shall jointly establish the plan for disposition and actions to be taken with respect to the hazardous materials, subject to final written approval by the District. All such costs shall be the responsibility of the District.

F. Exacerbation of Pre-Existing Hazardous Materials.

If during construction Contractor encounters pre-existing environmental conditions that it knew or should have known involve hazardous materials (the "Point of Discovery") (which encounters may include an unavoidable release or releases of hazardous materials) then Contractor must immediately stop the affected portion of the work. If Contractor fails to immediately stop the affected portion of the work after the Point of Discovery, then Contractor is solely responsible for any resultant Exacerbation Cost. "Exacerbate," in all its forms, means the worsening effects of Contractor's failure to stop the affected portion of work after the Point of Discovery. "Exacerbation Cost" means the differential between (i) the actual increase in the cost of remediation and delays to the Project attributable to pre-existing environmental conditions involving hazardous substances, and (ii) the cost thereof or delays thereto had Contractor immediately stopped the affected portion of the work after the Point of Discovery. The standard of "should have known" applies to Contractor's supervisory personnel, whether or not on the Site. Contractor's supervisory personnel must have had the hazardous material training required by applicable OSHA and CalOSHA rules or regulations.

SECTION 20. INDEPENDENT CONTRACTOR

- A. Contractor is retained as an independent contractor and is not employed by the District. No employee or agent of Contractor shall become, or be considered to be, an employee of the District for any purpose. It is agreed that the District is interested only in the results obtained from service under this Agreement and that Contractor shall perform as an independent contractor with sole control of the manner and

means of performing the services required under this Agreement. Contractor shall complete this Agreement according to its own methods of work which shall be in the exclusive charge and control of Contractor and which shall not be subject to control or supervision by the District except as to results of the work. It is expressly understood and agreed that Contractor and its employees shall in no event be entitled to any benefits to which the District employees are entitled, including, but not limited to, overtime, retirement benefits, insurance, vacation, worker's compensation benefits, sick or injury leave or other benefits.

- B. Contractor shall be responsible for all salaries, payments, and benefits for all of its officers, agents, and employees in performing services pursuant to this Agreement.

SECTION 21. ACCOUNTING RECORDS

Contractor, and all Subcontractors, shall check all materials, equipment and labor entering into the work and shall keep or cause to be kept such full and detailed accounts as may be necessary for proper financial management under this Agreement, including true and complete books, records and accounts of all financial transactions in the course of their activities and operations related to the Project. These documents include sales slips, invoices, payrolls, personnel records, requests for Subcontractor payment, and other data relating to all matters covered by the Contract Documents (the "Data"). The Data shall be maintained for ten (10) years from the latest expiration of the term (as such may be extended) of any of the Contract Documents. Contractor shall use its best efforts to cause its Subcontractors to keep or cause to be kept true and complete books, records and accounts of all financial transactions in the course of its activities and operations related to the Project. Upon completion of the Project, Contractor shall provide the District with one (1) complete copy of the Data.

The District, at its own costs, shall have the right to review and audit, upon reasonable notice, the books and records of Contractor and any Subcontractors concerning any monies associated with the Project.

SECTION 22. PERSONAL LIABILITY

Neither the trustees, officers, employees, or agents of District, the District's representative, or Architect shall be personally responsible for any liability arising under the Contract Documents.

SECTION 23. AGREEMENT MODIFICATIONS

No waiver, alteration or modification of any of the provisions of this Agreement shall be binding upon either the District or Contractor unless the same shall be in writing and signed by both the District and Contractor.

SECTION 24. NOTICES

Any notices or filings required to be given or made under this Agreement shall be served, given or made in writing upon the District or Contractor, as the case may be, by personal delivery or registered mail (with a copy sent via fax or regular mail) to the respective addresses given below or at such other address as such party may provide in accordance with the provisions herein. Any change in the addresses noted herein shall not be binding upon the other party unless preceded by no less than thirty (30) days prior written notice.

If to Contractor:

Swinerton Builders
865 S. Figueroa Street
Suite 3000
Los Angeles, CA 90017

Attn: Bonnie Martin

If to the District:

Oxnard School District
1051 South A Street
Oxnard, California 93030

Attn: Dr. Cesar Morales, Superintendent

With a copy to Nitasha Sawhney,
Garcia, Hernandez, Sawhney & Bermudez LLP
1330 Broadway, Suite 1701
Oakland, CA 94612

And with an additional copy to Yuri Calderon,
Caldwell Flores Winters, Inc.
6425 Christie Ave., Suite 270
Emeryville, CA 94608

Notices under this Agreement shall be deemed to have been given, and shall be effective upon actual receipt by the other parties, or, if mailed, upon the earlier of the fifth (5th) day after mailing or actual receipt by the other party.

SECTION 25. ASSIGNMENT

Neither party to this Agreement shall assign this Agreement or sublet it as a whole without the written consent of the other, nor shall Contractor assign any monies due or to become due to it hereunder without the prior written consent of the District.

SECTION 26. PROVISIONS REQUIRED BY LAW

Each and every provision of law and clause required to be inserted in these Contract Documents shall be deemed to be inserted herein and the Contract Documents shall be read and enforced as though it were included herein, and if through mistake or otherwise any such provision is not inserted or is not inserted correctly, then upon application of either party the Contract Documents shall forthwith be physically amended to make such insertion or correction.

SECTION 27. HEADINGS

The headings in this Agreement are inserted only as a matter of convenience and reference and are not meant to define, limit or describe the scope or intent of the Contract Documents or in any way to affect the terms and provisions set forth herein.

SECTION 28. APPLICABLE LAW

This Agreement shall be governed by and construed in accordance with the laws of the State of California. The parties irrevocably agree that any action, suit or proceeding by or among the District and Contractor shall be brought in whichever of the Superior Courts of the State of California, Ventura County, or the Federal Court for the Central District of California in Los Angeles, California, has subject matter jurisdiction over the dispute and waive any objection that they may now or hereafter have regarding the choice of forum whether on personal jurisdiction, venue, forum non conveniens or on any other ground.

SECTION 29. SUCCESSION OF RIGHTS AND OBLIGATIONS

All rights and obligations under this Agreement shall inure to and be binding upon the successors and assigns of the parties hereto.

SECTION 30. NOTIFICATION OF THIRD PARTY CLAIMS

The District shall provide Contractor with timely notification of the receipt by the District of any third party claim relating to this Agreement, and the District may charge back to Contractor the cost of any such notification.

SECTION 31. SEVERABILITY

If any one or more of the terms, covenants or conditions of this Agreement shall to any extent be declared invalid, unenforceable, void or voidable for any reason whatsoever by a court of competent jurisdiction, the finding or order or decree of which becomes final, none of the remaining terms, provisions, covenants and conditions of the Contract Documents shall be affected thereby, and each provision of the Contract Documents shall be valid and enforceable to the fullest extent permitted by law.

SECTION 32. ENTIRE AGREEMENT

This Construction Services Agreement and the additional Contract Documents as defined in paragraph C of Section 1 herein, including the Site Lease, the Sublease, and the Specifications, drawings, and plans constitute the entire agreement between Contractor and the District. The Contract Documents shall not be amended, altered, changed, modified or terminated without the written consent of both parties hereto, except as otherwise provided in Section 10 hereof.

SECTION 33. EXECUTION IN COUNTERPARTS

This Agreement may be executed in any number of counterparts, each of which shall be an original, but all of which together shall constitute one instrument.

IN WITNESS WHEREOF the parties hereto, intending to be legally bound thereby, have executed this Agreement effective as of the date first above written.

CONTRACTOR

Swinerton Builders

By:  LIA TATEVOSIAN
Title: OPERATIONS MGR
Date: 4/6/16

THE DISTRICT

Oxnard School District,
a California school district

By: 
Title: District Superintendent
Date: April 26, 2016

EXHIBIT A

Scope of Work

The scope of Work for the Lemonwood Reconstruction Project consists of the construction of a new school, including a Kindergarten, Classroom, Administration and Multipurpose Building, as more specifically described in the DSA Approved plans, specifications and Construction Change Directives ("CCDs"). The following construction documents are referenced herein and incorporated into this contract for all purpose to more fully describe the scope of work contemplated and agreed to by the parties:

1. DSA Approved drawings for DSA Application # 03-116026.
2. DSA Approved Project Manual for DSA Application # 03-116026.
3. Addendum 01 dated 11/16/2015 for DSA Application # 03-116026 as issued to Swinerton Builders on 11/16/2015 by SVA Architects.
4. Addendum 02 dated 11/18/2015 for DSA Application # 03-116026 as issued to Swinerton Builders on 11/18/2015 by SVA Architects.
5. Addendum 03 dated 11/30/2015 for DSA Application # 03-116026 as issued to Swinerton Builders on 11/30/2015 SVA Architects.
6. Project Schedule prepared by Contractor and approved by Owner (Attached hereto).
7. Agreed Upon List of Qualifications (Attached hereto).
8. Pre-bid and Post-Bid Value Management Logs (Attached hereto).
9. Lemonwood GMP Qualification Matrix (Attached hereto).

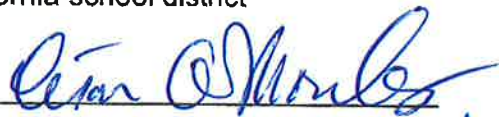
BOARD AGENDA ITEM

Name of Contributor: Dr. Morales/Lisa Cline

Date of Meeting: 3/01/17

STUDY SESSION _____

CLOSED SESSION _____

SECTION A-1: PRELIMINARY _____

SECTION A-II: REPORTS _____

SECTION B: HEARINGS _____

SECTION C: CONSENT AGENDA _____

Agreement Category:

____ Academic

____ Enrichment

____ Special Education

____ Support Services

____ Personnel

____ Legal

X Facilities

SECTION D: ACTION _____

SECTION F: BOARD POLICIES 1st Reading _____ 2nd Reading _____

Approval of Dispersal No. 004 from the Lemonwood E.S. Reconstruction Project's Contractor Contingency for payment of Additional Work associated with the Project (Morales/Cline/CFW)

The Oxnard School District ("District") Board of Trustees ("Board") Facilities Implementation Plan first adopted in January 2013, calls for the reconstruction of the Lemonwood K-8 School ("Project"). The Project includes the construction of a new school facilities at the existing Lemonwood school site. The new facilities will provide for a complete K-8 educational program and will consist of a new combined administration and library building, a new multi-purpose room/gymnasium, a 2-story classroom building, kindergarten classroom building and playfields, hardscape and green space to service the new school.

During the Regular Meeting of March 2, 2016, the Board of Trustees Approved Item D-5, the Construction Services Agreement between the Oxnard School District and Swinerton Builders for the Project. During that Meeting, the inclusion of a Seven Hundred Forty-Seven Thousand Seven Hundred Nine Dollar (\$747,709.00) Contractor Contingency was explained. The Contractor Contingency is for payment of very specific items of Work: (1) additional costs resulting from discrepancies in the bid buy-out process; (2) conflicts, discrepancies or errors in the Construction Documents; (3) work required by the Inspector of Record or any governmental agency involved with the permitting or approval/certification process that is not otherwise shown in the Construction Documents; and (4) any other items of cost agreed to in writing by the Contractor and District to be included in the Contractor Contingency.

During the regular Meeting of December 7, 2016, the Board approved Contingency Allocation No. 001, which was for the cost of an interim access ramp and landing, serving relocatable classrooms No.'s 909, 910, 911 and 912. The Interim Ramp became a requirement, due to a discrepancy in the Construction Documents. The existing ramp and landing were found to conflict with required excavation for the new Multi-Purpose Building's foundation. Contingency Allocation No. 001 did not increase the Contract duration time.

During the regular meeting of February 1, 2017, the Board approved a combination of eleven (11) different Proposed Change Order Items due to discrepancies or errors in the Construction Documents. Contractor Contingency Allocation No. 002 did not increase Contract Time.

During the regular meeting of February 1, 2017, the Board also approved a combination of seven (7) Proposed Change Order Items due to discrepancies or errors in the Construction Documents and due to work required by the Inspector of Record or any governmental agency involved with the permitting or approval/certification process that is not otherwise shown in the Construction Documents. Contractor Contingency Allocation No. 003 did not increase Contract Time.

This recommended agenda item provides for the Board's consideration and approval of a combination of nine (9) different Proposed Change Order Items; detailed in the attached Contractor Contingency Allocation Form, with all Proposed Change Order Items in conformance with criteria's No. 2 and 3; as referenced above: "(2) conflicts, discrepancies or errors in the Construction Documents; (3) work required by the Inspector of Record or any governmental agency involved with the permitting or approval/certification process that is not otherwise shown in the Construction Documents." Contractor Contingency Allocation No. 004 will not increase Contract Time.

FISCAL IMPACT

Contractor Contingency Allocation No. 004 will be deducted from the Contractor Contingency line item of the GMP Construction Services Agreement in the amount of **Three Hundred Five Thousand Seven Hundred Fifty-Two Dollars and Sixty-Two Cents** (\$305,752.62). The Contractor Contingency is included within the approved total of the Construction Services Agreement for the Lemonwood K-8 Reconstruction Project. The Remaining Contractor Contingency Balance after Allocation No. 004 will be **Three Hundred Twelve Thousand One Hundred Seventy-Two Dollars and Sixty Cents**. (\$312,172.60).

RECOMMENDATION

It is the recommendation of the Superintendent, and the Deputy Superintendent, Business and Fiscal Services, in conjunction with Caldwell Flores Winters, Inc., that the Board of Trustees approve Contingency Allocation No. 004 to the Construction Services Agreement #15-198 with Swinerton Builders, for additional items of Work related to the Lemonwood Elementary School Reconstruction Project of Measure "R" Program under the Lease-Leaseback delivery method pursuant to Section 17406 of the California Education Code.

ADDITIONAL MATERIAL

Attached:

- *Contingency Allocation No. 004, Swinerton Builders (3 Pages)*
- *Swinerton PCI No. 0006-1 (8 Pages)*
- *Swinerton PCI No. 0026 (14 Pages)*
- *Swinerton PCI No. 0055-1 (27 Pages)*
- *Swinerton PCI No. 0086 (9 Pages)*
- *Swinerton PCI No. 0092 (4 Pages)*
- *Swinerton PCI No. 0093 (18 Pages)*
- *Swinerton PCI No. 0123 (3 Pages)*
- *Swinerton PCI No. 0124 (3 Pages)*
- *Swinerton PCI No. 0141 (4 Pages)*
- *Construction Services Agreement #15-198, Swinerton Builders (19 Pages)*



CONTRACTOR CONTINGENCY ALLOCATION APPROVAL

Date: March 1, 2017

CONTRACTOR CONTINGENCY ALLOCATION NO. 004

PROJECT: LEMONWOOD K-8 RECONSTRUCTION PROJECT OWNER: Oxnard School District
 O.S.D. BID No. N/A 1051 South A Street
 O.S.D. Agreement No.15-198 Oxnard, CA. 93030

ARCHITECT SVA Architects, Inc.
 3 MacArthur Place, Suite 850
 Santa Ana, CA 92707

CONTRACTOR:
 Swinerton Builders
 865 S. Figueroa St., Ste. 3000
 Los Angeles, CA 90017
 Attn: Michael Darquea

Architects Proj. No.: 2013-40121
 D.S.A. File No.: 56-22
 D.S.A. App. No.: 03-116026

CONFORMANCE WITH CONTRACT DOCUMENTS, PROJECT MANUAL, DRAWINGS AND SPECIFICATION. All Contractor Contingency Allocation work shall be in strict conformance with the Contract Documents, Project Manual, Drawings, and Specifications as they pertain to work of a similar nature.

| | |
|---|------------------------|
| ORIGINAL CONTRACTOR CONTINGENCY SUM | \$ 747,709.00 |
| NET CHANGE - ALL PREVIOUS CONTRACTOR CONTINGENCY ALLOCATIONS | (\$ 129,783.78) |
| ADJUSTED CONTINGENCY SUM | \$ 617,925.22 |
| NET CHANGE - | (\$ 295,627.27) |
| <hr/> | |
| Total Contingency Allocations to Date: | (\$ 425,411.05) |
| ADJUSTED CONTRACTOR CONTINGENCY SUM THROUGH NO.:002 | \$ 322,297.95 |
| Commencement Date: | May 23, 2016 |
| Original Completion Date: | July 23, 2018 |
| Original Contract Time:..... | 791 Calendar Days |
| Time Extension for all Previous Contractor Contingency Allocations: | No Days |
| Time Extension for this Contractor Contingency Allocation Order: | No Days |
| Adjusted Completion Date: | July 23, 2016 |
| Percentage | 0% |

| Item | Description | Additional Cost related to Bid/Buy-out | Conflicts, Discrepancies or Errors in the Construction Documents | Additional Work required by IOR, or another Jurisdictional Agency, not in plans | Other Item of Cost agreed to by District and Contractor |
|------|---|--|--|---|---|
| 1. | PCI 006-1 On-site domestic and fire water system modification. | | | \$165,763.18 | |
| 2. | PCI 0026 Added makeup air duct work and grilles | | \$3,435.14 | | |
| 3. | PCI 0055-1 Change electrical duct bank requirements | | \$32,543.00 | | |
| 4. | PCI 086 Add hub drains to the FS system for Bldgs 3, 4 and 5 | | \$19,429.04 | | |
| 5. | PCI 0092 Add beam hanger | | \$489.06 | | |
| 6. | PCI 0093 Modify HVAC units and related duct work and structural roof framing | | \$33,426.59 | | |
| 7. | PCI 0123 Add ledgers at 2 nd floor to receive hangers | | \$7,512.33 | | |
| 8. | PCI 0124 Add wood frame posts and hold downs along gridline D from ground floor to roof | | \$6,176.93 | | |
| 9. | PCI 0141 Add roof framing supports and waterproof roof penetrations in Classroom Bldg | | \$26,852.00 | | |
| | Totals | | \$129,864.09 | \$165,763.18 | |

Total Contractor Contingency Allocation Approval No. 004 \$295,627.27

**NOT VALID UNTIL SIGNED BY THE ARCHITECT, CONTRACTOR AND DEPUTY SUPT. BUSINESS SERVICES OR PURCHASING DIRECTOR*

APPROVAL (REQUIRED):

ARCHITECT: _____

DATE: _____

CONTRACTOR: _____

DATE: _____

RECOMMENDED FOR APPROVAL:

DEPUTY SUPERINTENDENT BUSINESS AND FISCAL SERVICES:

DATE: _____

APPROVAL (REQUIRED):

DEPUTY SUPT./PURCHASING DIRECTOR: _____

DATE: _____



January 18, 2017

*2/7/17
Contingency
Approved -
Required by City of Oxnard.*

Oxnard School District
1051 South A Street
Oxnard, CA, 93030

Attn: Ms. Marlene Hickle / CFW, Inc

Subject: Swinerton Builders Job 16055106 - Lemonwood K-8 School LLB
PCI No. 0006.1 Modification to the on-site and off-site domestic and fire water system based on review comments by the City of Oxnard.

Dear Ms. Hickle,

We request a Change Order to our contract for the following:

Modification to the on-site and off-site domestic and fire water system based on review comments by the City of Oxnard. Major changes include the following:

- Addition of hydrant fire water street tap off San Mateo.
- Addition of domestic water street tap, pressure regulator, RPDA, and roughly 150' of pipe at San Mateo.
- Relocation of building fire water street tap on San Mateo.
- Addition of approximately 1,007 LF (as drawn) of building and hydrant fire water piping (LF of pipe will grow a bit once new coordination is done factoring the new easement in.).
- Addition of hydrant fire water street tap on Carnegie.
- Addition of 15' and 25' easements for hydrant fire water service affecting coordination and other utilities.

| Phase | Category | Description | Subcontractor | Quote |
|--------|----------|--|------------------------------------|-------------------|
| 013035 | 71151 | Review documents, coordinate trades and services. Site Sr. Superintendent | Swinerton Builders | 1,165.52 |
| 013189 | 71152 | Underground utility BIM coordination with new Site Fire Water | Swinerton Builders | 2,073.28 |
| 017125 | 71140 | Construction Surveying | ADKAN ENGINEERS, INC. | 4,400.00 |
| 024100 | 71140 | Hazardous material removal-8" AC pipe removal at new 8" fire hydrant connections | AMERICAN INTEGRATED SERVICES, INC. | 4,375.00 |
| 330200 | 71140 | Site Utilities | BALI CONSTRUCTION INC. | 140,000.00 |
| | | | Subtotal | 152,013.80 |
| 007480 | 71160 | Subguard | 1.15% | 1,748.16 |
| 007410 | 71160 | Builders Risk | 0.6% | 922.57 |
| 007420 | 71160 | General Insurance | 1.15% | 1,768.26 |
| 007510 | 71160 | P&P Bond | 1% | 1,487.75 |
| 991000 | 79999 | Change Order Fee | 5% | 7,822.64 |

MJK 2/7/17 TB 2/7/17

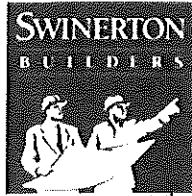

| | | | | |
|--|--|--|------------------------|-------------------|
| | | | Markup Subtotal | 13,749.38 |
| | | | PCI Total | 165,763.18 |

TOTAL AMOUNT OF THIS CHANGE ORDER REQUEST: **165,763.18.**

Please NOTE:

- » The incorporation of this revision in to the contractual scope of work may have an impact on our schedule, which is yet to be finalized. Once determined, the job schedule and cost will be adjusted accordingly to show the effect of this revision on the final project completion date.
- » The terms (cost and schedule impact) of this change order request are subject to review and a requote if not accepted within 5 days of its issuance.
- » This request does not include additional cost or delay due to late approval.

X We **HAVE NOT** proceeded with this revised work per your instructions. Please issue a change order.

Upon acceptance of this change order request, a formal change order will be issued. Acceptance also acknowledges that Swinerton Builders is directed to proceed with the above change in scope.

If you have any questions or comments pertaining to this matter, please contact the undersigned.

Sincerely,
Swinerton Builders

Bill Gray
PM
Date: _____

1/18/2017

Quotation accepted by:
Oxnard School District

By: _____

Date: _____

December 15, 2016

Swinerton Builders
17731 Mitchell North #200
Irvine, CA 92614

Attention: Bill Gray – Project Manager

Reference: Lemonwood K-8 School
2200 Carnegie Court
Oxnard, CA 93033
GC Job No.: 16055106
Bali Job No.: 16-043

Subject: Change Order Request No. 6
Waterline Changes from Bid to CCD 6 and Approved Off-site Plans

Gentlemen,

We hereby submit our Change Order Request No. 6 for the revised water work per CCD 6 and Approved Off-site plans for the referenced project. Attached with this letter is a detailed breakdown of the additional cost associated with this work. The following is a summary.

Waterline Changes from Bid to CCD 6 and Approved Off-site Plans \$149,500.00

Please issue a Change Order.

If you have any questions, please call us. Thank you.

Respectfully yours,
Bali Construction, Inc.

Kevin Delate

Bali Construction, Inc.
Change Order Request No. 6

| Description | Units | Quantity | Unit Price | Extension |
|--|--------|----------|------------|---------------------|
| Equipment | | | | |
| Excavator 9060 (100,000lb) | hr | 0 | \$201.65 | \$0.00 |
| Excavator 9050 (70,000lb) | hr | 0 | \$158.92 | \$0.00 |
| Excavator (50,000lb) | hr | 0 | \$140.06 | \$0.00 |
| Excavator (28,800lb) | hr | 0 | \$118.00 | \$0.00 |
| Loader (3.5cy) | hr | 0 | \$91.17 | \$0.00 |
| Backhoe | hr | 176 | \$58.00 | \$10,208.00 |
| Water Truck (2,000gal) | hr | 60 | \$50.98 | \$3,058.80 |
| Boom Truck (14ton) | hr | 0 | \$45.00 | \$0.00 |
| Dump Truck (10-12cy) (Operated) | hr | 8 | \$90.00 | \$720.00 |
| Dump Truck (6cy) | hr | 80 | \$63.01 | \$5,040.80 |
| Utility Truck w Fuel Tank (2 ton) | hr | 176 | \$33.53 | \$5,901.28 |
| Utility Truck w Generator (2 ton) (Carpenters) | hr | 8 | \$33.53 | \$268.24 |
| Bobcat | hr | 0 | \$40.00 | \$0.00 |
| Sawcutting (Operated w/ Mobilization) | hr | 8 | \$150.00 | \$1,200.00 |
| Traffic Control | ls | 1 | \$200.00 | \$200.00 |
| Mobilization (Move In & Out) | ls | 0 | \$3,000.00 | \$0.00 |
| Air Compressor w/ tools | day | 0 | \$95.00 | \$0.00 |
| Traffic Plate (w/ Delivery In & Out) | ls | 1 | \$1,396.00 | \$1,396.00 |
| Shoring (w/ Delivery In & Out) | ls | 1 | \$300.00 | \$300.00 |
| Roller For AC Patch | day | 1 | \$450.00 | \$450.00 |
| Delivery | hr | 0 | \$125.00 | \$0.00 |
| Equipment Subtotal | | | | \$28,743.12 |
| Subcontractor | | | | |
| Disinfection of Added Domestic Waterline | ls | 1 | \$1,500.00 | \$1,500.00 |
| | | | | |
| | | | | |
| | | | | |
| | | | | |
| | | | | |
| | | | | |
| Subtotal Subcontractor | | | | \$1,500.00 |
| Subtotal Cost | | | | \$130,130.71 |
| Markup Material | 15.00% | | | \$5,283.38 |
| Markup Labor | 15.00% | | | \$9,699.76 |
| Markup Equipment | 15.00% | | | \$4,311.47 |
| Markup Subcontractor | 5.00% | | | \$75.00 |
| Subtotal Change Order Request | | | | \$149,500.31 |
| Bond | 0.00% | | | \$0.00 |
| Total Change Order Request | | | | \$149,500.31 |

ADDITION

WESTERN WATER WORKS SUPPLY CO

PROPOSAL



2024 MERCED AV
S EL MONTE, CA - 91733
PHONE: (909)597-7000 FAX: (626)579-1389

| PROPOSAL ID | QUOTE NO. | DATE |
|---------------|-----------|----------|
| LEMONWOOD ADD | 32649 | 12/14/16 |

Smooth Running Jobs

| LN# | PRODUCT AND DESCRIPTION | QTY | UM | PRICE | TOTAL | |
|-----|-------------------------|-------|--|--------|---------|---------|
| 1 | 4 " PIPE | | | | | |
| 2 | DR14-04 | 4 | CL305 DR14 C900 PVC PIPE | 460 FT | 3.15 | 1449.00 |
| 3 | M90-04 | 4 | DI SSB MJ 90 | 2 EA | 37.00 | 74.00 |
| 4 | RGPA-04 | 4 | MJ RESTRAINT W/ACC C900 PVC PIPE - ROMAC | 4 EA | 43.13 | 172.52 |
| 5 | 4 " PIPE | | SUBTOTAL | | | 1695.52 |
| 6 | 6 " PIPE | | | | | |
| 7 | DR14-06 | 6 | CL305 DR14 C900 PVC PIPE | 560 FT | 6.08 | 3404.80 |
| 8 | M90-06 | 6 | DI SSB MJ 90 | 5 EA | 60.50 | 302.50 |
| 9 | RGPA-06 | 6 | MJ RESTRAINT W/ACC C900 PVC PIPE - ROMAC | 10 EA | 54.52 | 545.20 |
| 10 | 6 " PIPE | | SUBTOTAL | | | 4252.50 |
| 11 | 8 " PIPE | | | | | |
| 12 | DR14-08 | 8 | CL305 DR14 C900 PVC PIPE | 560 FT | 10.46 | 5857.60 |
| 13 | M90-08 | 8 | DI SSB MJ 90 | 2 EA | 88.00 | 176.00 |
| 14 | RGPA-08 | 8 | MJ RESTRAINT W/ACC C900 PVC PIPE - ROMAC | 4 EA | 73.83 | 295.32 |
| 15 | 8 " PIPE | | SUBTOTAL | | | 6328.92 |
| 16 | 2 " SERVICE | | | | | |
| 17 | 202B-962-CC7 | 8X2 | CC BRZ SADDLE 899-967 | 1 EA | 162.73 | 162.73 |
| 18 | FB1000-7 | 2 | BALLCORP CC X PJ CTS | 1 EA | 246.14 | 246.14 |
| 19 | KS20-200 | 2 | K SOFT COPPER TUBING 20FT LENGTH | 40 FT | 15.44 | 617.60 |
| 20 | CC-02 | 2 | COPPER CPLG SXS LESS STOP | 1 EA | 15.40 | 15.40 |
| 21 | C90-02 | 2 | COPPER 90 SXS | 1 EA | 24.08 | 24.08 |
| 22 | FV43-777W | 2 | ANGLE MTR VLV PJ CTS | 2 EA | 235.73 | 471.46 |
| 23 | 666B-MB | 666B | H&C CONC MTR BOX ONLY | 1 EA | 32.63 | 32.63 |
| 24 | 666B-2PC | 666B | H&C CONC 2 PC COVER LESS LID | 1 EA | 24.76 | 24.76 |
| 25 | 666B-RL | 666B | H&C CONC READING LID ONLY / 3 CONC CVR | 1 EA | 7.36 | 7.36 |
| 26 | 2 " SERVICE | | SUBTOTAL | | | 1602.16 |
| 27 | 2-1/2 PR | | | | | |
| 28 | KS20-250 | 2-1/2 | K SOFT COPPER TUBING 20FT LENGTH | 20 FT | 26.72 | 534.40 |
| 29 | C90-250# | 2-1/2 | SXS 90 COPPER | 4 EA | 42.67 | 170.68 |
| 30 | BF-250# | 2-1/2 | FLANGES | 2 EA | 357.14 | 714.28 |
| 31 | C500-250# | 2-1/2 | AMES RP ASSY | 1 EA | 3666.67 | 3666.67 |
| 32 | BN3 | 2-3 | B/N SET 150# FLG 5/8X2-1/2 | 4 EA | 2.57 | 10.28 |
| 33 | JM60-025 | 2-1/2 | RING GASKET 1/16 NON-ASBESTOS | 4 EA | 1.14 | 4.56 |
| 34 | 2-1/2 PR | | SUBTOTAL | | | 5100.87 |

Continued



WESTERN WATER WORKS SUPPLY CO

PROPOSAL

2024 MERCED AV
 S EL MONTE, CA - 91733
 PHONE: (909)597-7000 FAX: (626)579-1389

| PROPOSAL ID | QUOTE NO. | DATE |
|---------------|-----------|----------|
| LEMONWOOD ADD | 32649 | 12/14/16 |

Smooth Running Jobs

| LN# | PRODUCT AND DESCRIPTION | QTY | UM | PRICE | TOTAL |
|-----|--|-----|-----|---------|---------|
| 35 | 3" REDUCE PRESSURE VLV | | | | |
| 36 | RP-250# 3" RP VALVE | 1 | EA | 1133.33 | 1133.33 |
| 37 | 3" REDUCE PRESSURE VLV SUBTOTAL | | | | 1133.33 |
| 38 | 6X6 TAP | | | | |
| 39 | FAST-730-6A 6X6 SS TAP SLV 690-730 | 1 | EA | 724.07 | 724.07 |
| 40 | BN6-8 6-8 B/N SET 150# PLATED A307 3/4X3-1/4 | 1 | SET | 9.46 | 9.46 |
| 41 | JM60-06 6 RING GASKET 1/16 NON-ASBESTOS | 1 | EA | 2.72 | 2.72 |
| 42 | RGPA-06 6 MJ RESTRAINT W/ACC C900 PVC PIPE - ROMAC | 1 | EA | 54.52 | 54.52 |
| 43 | 10-VE 10 H&C VLV BOX | 1 | EA | 80.00 | 80.00 |
| 44 | 10-VC-WATER 10 H&C CI COVER "WATER" | 1 | EA | 74.67 | 74.67 |
| 45 | SCH40-08 8 SCH40 PVC PIPE BE | 5 | FT | 7.58 | 37.90 |
| 46 | 6X6 TAP SUBTOTAL | | | | 983.34 |
| 47 | 8X8 TEE | | | | |
| 48 | MPT-0808 8X8 DI SSB MJXFLG TEE | 1 | EA | 144.00 | 144.00 |
| 49 | RGPA-08 8 MJ RESTRAINT W/ACC C900 PVC PIPE - ROMAC | 2 | EA | 73.83 | 147.66 |
| 50 | GVFM-08 8 FLGXMJ RW GATE VLV OL NDZ STEM 316 B/N | 1 | EA | 1183.39 | 1183.39 |
| 51 | BN6-8 6-8 B/N SET 150# PLATED A307 3/4X3-1/4 | 1 | SET | 9.46 | 9.46 |
| 52 | JM60-08 8 RING GASKET 1/16 NON-ASBESTOS | 1 | EA | 3.54 | 3.54 |
| 53 | RGPA-08 8 MJ RESTRAINT W/ACC C900 PVC PIPE - ROMAC | 3 | EA | 73.83 | 221.49 |
| 54 | 10-VE 10 H&C VLV BOX | 1 | EA | 80.00 | 80.00 |
| 55 | 10-VC-WATER 10 H&C CI COVER "WATER" | 1 | EA | 74.67 | 74.67 |
| 56 | SCH40-08 8 SCH40 PVC PIPE BE | 5 | FT | 7.58 | 37.90 |
| 57 | XR501-08 8 EXT RANGE CPLG 840-975 SS B/N EPOXY | 2 | EA | 323.87 | 647.74 |
| 58 | 8X8 TEE SUBTOTAL | | | | 2549.85 |
| 59 | 6 " RP | | | | |
| 60 | MF90-06 6 DI SSB MJXFLG 90 | 4 | EA | 69.23 | 276.92 |
| 65 | RGPA-06 6 MJ RESTRAINT W/ACC C900 PVC PIPE - ROMAC | 4 | EA | 54.52 | 218.08 |
| 66 | 6FF60 6 FLG X 6'-0" SPOOL | 4 | EA | 368.31 | 1473.24 |
| 67 | F90-06 6 DI FLG 90 | 4 | EA | 97.85 | 391.40 |
| 68 | BN6-8 6-8 B/N SET 150# PLATED A307 3/4X3-1/4 | 12 | SET | 9.46 | 113.52 |
| 69 | JM60-06 6 RING GASKET 1/16 NON-ASBESTOS | 12 | EA | 2.72 | 32.64 |
| 70 | 375-06 6 WILKINS 375 RP W/OSY GATE VALVE | 2 | EA | 3220.00 | 6440.00 |
| 71 | 6 " RP SUBTOTAL | | | | 8945.80 |

2 BID TOTAL

32592.29

Continued

CREDIT



WESTERN WATER WORKS
SUPPORT CENTER
5831 PINE AV
CHINO HILLS, CA - 91709
PHONE: (909)597-7000 FAX: (909)597-7050

Smooth Running Jobs

ACKNOWLEDGEMENT Return Merchandise

| | | |
|-----------|-------------|-----------|
| UPC | ORDER DATE | ORDER NO. |
| 000000 | 12/14/16 | 439077-00 |
| P.O. DATE | P.O. NUMBER | PAGE NO. |
| 12/14/16 | 16-043 | 1 of 2 |



CUST #: 2040

BILL TO: BALI CONST INC
9852 E JOE VARGAS WY
S EL MONTE, CA 91733-3095

SHIP TO: BALI CONST INC
9852 E JOE VARGAS WY
S EL MONTE, CA 91733-3095

INSTRUCTIONS: KEVIN

| | | | | |
|----------------------|-----------|---------|-------------|---------|
| SHIP POINT | VIA | SHIPPED | TERMS | CONTACT |
| SEL - S EL MONTE, CA | WILL CALL | | NET 30 DAYS | |

| LN | PRODUCT AND DESCRIPTION | ORDERED | BO | SHIPPED | UM | PRICE | UM | DISCOUNT | NET AMOUNT |
|----------------|---|---------|-------------------|---------|-----|---------|-------|----------|------------|
| 1 | MR-0806 8X6 DI SSB MJ RED | 2- | | 2- | EA | 36.00 | EA | 0.00 | 72.00 - |
| 2 | RGPA-08 8 MJ RESTRAINT W/ACC C900 PVC PIPE - ROMAC | 2- | | 2- | EA | 52.12 | EA | 0.00 | 104.24 - |
| 3 | RGPA-06 6 MJ RESTRAINT W/ACC C900 PVC PIPE - ROMAC | 2- | | 2- | EA | 38.48 | EA | 0.00 | 76.96 - |
| 4 | MT-0808 8 DI SSB MJ TEE | 1- | | 1- | EA | 92.82 | EA | 0.00 | 92.82 - |
| | RGPA-08 8 MJ RESTRAINT W/ACC C900 PVC PIPE - ROMAC | 3- | | 3- | EA | 52.12 | EA | 0.00 | 156.35 - |
| 6 | MF90-08 8 DI SSB MJXFLG 90 | 4- | | 4- | EA | 92.12 | EA | 0.00 | 368.47 - |
| 7 | RGPA-08 8 MJ RESTRAINT W/ACC C900 PVC PIPE - ROMAC | 4- | | 4- | EA | 52.12 | EA | 0.00 | 208.47 - |
| 8 | BFF50 8 FLG X 5'-0" SPOOL | 4- | | 4- | EA | 340.94 | EA | 0.00 | 1363.76 - |
| 9 | F90-08 8 DI FLG 90 | 4- | | 4- | EA | 123.18 | EA | 0.00 | 492.71 - |
| 10 | BN6-8 6-8 B/N SET 150# PLATED A307 3/4X3-1/4 | 12- | | 12- | SET | 6.76 | SET | 0.00 | 81.09 - |
| 11 | JM60-08 8 RING GASKET 1/16 NON-ASBESTOS | 12- | | 12- | EA | 2.53 | EA | 0.00 | 30.34 - |
| 12 | 375-08 8 WILKINS 375 RP W/NRS GATE VALVE | 2- | | 2- | EA | 4814.77 | EA | 0.00 | 9629.55 - |
| 12 Lines Total | | | Qty Shipped Total | 52- | | | Total | | 12676.76 - |

Continued

In accordance with California law AB 1953 "Lead Free" initiative, beginning June 15, 2009 we will no longer accept returns for 85/5/5 brass products.



December 21, 2016

Oxnard School District
1051 South A Street
Oxnard, CA, 93030

Attn: Ms. Marlene Hickle, CFW Inc.

Subject: Swinerton Builders Job 16055106 - Lemonwood K-8 School LLB
PCI No. 0026 Water Heater Make up air RFI 0079

*Approved -
2/7/17
Contingency
Originally In Design
Taken out in Addenda #1
By Cook Required.
Mechanical Design
Different*

Dear Ms. Hickle,

We request a Change Order to our contract for the following:

Add make up air duct work, dampers and grilles

| Phase | Category | Description | Subcontractor | Quote |
|--------|----------|---------------------------------------|--------------------------------|-----------------|
| 230010 | 71140 | Add make up air duct work and grilles | SHELDON MECHANICAL CORPORATION | 2,878.00 |
| | | | Subtotal | 2,878.00 |
| 007480 | 71160 | Subguard | 1.15% | 33.10 |
| 007410 | 71160 | Builders Risk | 0.6% | 17.47 |
| 007420 | 71160 | General Insurance | 1.15% | 33.48 |
| 007510 | 71160 | P&P Bond | 1% | 28.78 |
| 991000 | 79999 | Change Order Fee | 15% | 444.31 |
| | | | Markup Subtotal | 557.14 |
| | | | PCI Total | 3,435.14 |

CS-

TOTAL AMOUNT OF THIS CHANGE ORDER REQUEST: **3,435.14**. *Mark-up Discussion Needed.*

Please NOTE:

- » The incorporation of this revision in to the contractual scope of work may have an impact on our schedule, which is yet to be finalized. Once determined, the job schedule will be adjusted accordingly to show the effect of this revision on the final project completion date.
- » The terms (cost and schedule impact) of this change order request are subject to review and a requote if not accepted within days of its issuance.
- » This request does not include additional cost or delay due to late approval.

We **HAVE NOT** proceeded with this revised work per your instructions. Please issue a change order.

2/9/17 ml. TB 2/7/17



Upon acceptance of this change order request, a formal change order will be issued. Acceptance also acknowledges that Swinerton Builders is directed to proceed with the above change in scope.

If you have any questions or comments pertaining to this matter, please contact the undersigned.

Sincerely,
Swinerton Builders

A handwritten signature in black ink, appearing to read "Bill Gray", is written over the printed name.

Bill Gray

PM

Date: _____

12/21/2016

Quotation accepted by:
Oxnard School District

By: _____

Date: _____

RFI 0026

SHELDON MECHANICAL CORPORATION

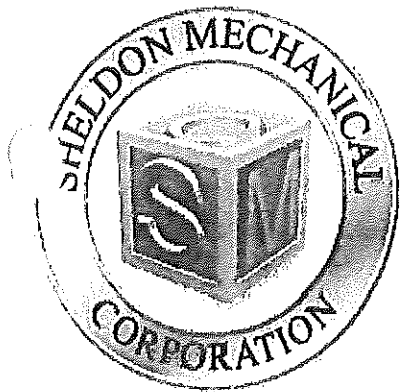

December 21, 2016

Swinerton
865 S. Figueroa Suite 3000
Los Angeles, Ca. 90017

Attn: Mr. Bill Gray

Subject: Lemonwood K-8 School
SMC COR #3 RFI #00079

Dear Bill,

Attached is our itemized cost to furnish and install (1) Fire Smoke Damper with an extended sleeve and duct access door as well as furnish and install (2) Diffusers per RFI #00079.

Cost for SMC COR #3 is \$2,878.00

If you have any questions please call me.

Sincerely,

Dillon J. Boute

Dillon J. Boute

| | |
|------|----------------------|
| Data | Sheldon 3/19/04 |
| Job | Lemonwood K-8 School |
| Bid | SMC COR #3 |

Sheldon Mechanical Corporation
26015 avenue hall
Santa Clarita, CA 91355

Phone: 661-286-1361

FAX: 661-287-9081

| | |
|----------|------|
| DATE | PAGE |
| 12/16/16 | 1 |
| TIME | |
| 05:23 PM | |

| Description | Ref | Ref Amount | Op | Rate | Amount |
|-------------------------|---------|------------|----|--------|----------|
| 1 MATERIAL: | | | | | |
| 2 DFI Invoice | | | | | 385.00 |
| 3 SUBTOTAL | | | | | 385.00 |
| 4 | | | | | |
| 5 MAJOR QUOTATIONS: | | | | | |
| 6 EQUIPMENT: | | | | | |
| 7 | | | | | |
| 8 AIR DISTRIBUTION: | | | | | |
| 9 NSW | | | | | 100.00 |
| 10 2 Diffusers | | | | | |
| 11 | | | | | |
| 12 DAMPERS: | | | | | |
| 13 NSW | | | | | 430.00 |
| 14 1 Fire/Smoke | | | | | |
| 15 SUBTOTAL | | | | | 530.00 |
| 16 | | | | | |
| 17 SALES TAX: | | | | | |
| 18 Material Total | Line 3 | 385.00 | % | 9.00 | 34.65 |
| 19 Major Quotations | Line 15 | 530.00 | % | 8.00 | 42.40 |
| 20 SUBTOTAL | | | | | 77.05 |
| 21 | | | | | |
| 22 DIRECT FIELD LABOR: | | | | | |
| 23 Layout | Calc | 1.00 | * | 116.10 | 116.10 |
| 24 Install 2 Diffusers | Calc | 4.00 | * | 96.95 | 387.80 |
| Install 1 FSD | Calc | 3.00 | * | 96.85 | 290.55 |
| 25 SUBTOTAL | | | | | 794.45 |
| 26 | | | | | |
| 27 | | | | | |
| 28 NON-PROD LABOR HRS: | | | | | |
| 29 Shop Drawings | Calc | 1.00 | * | 106.10 | 106.10 |
| 30 Detailing | Calc | 1.00 | * | 116.10 | 116.10 |
| 31 Cleanup | Calc | 1.00 | * | 96.85 | 96.85 |
| 32 SUBTOTAL | | | | | 319.05 |
| 33 | | | | | |
| 34 DIRECT JOB EXPENSES: | | | | | |
| 35 Freight | Calc | 4.00 | * | 75.00 | 300.00 |
| 36 Material Handling | Calc | 1.00 | * | 96.85 | 96.85 |
| 37 SUBTOTAL | | | | | 396.85 |
| 38 | | | | | |
| 39 JOB SUBTOTAL | | | | | 2,502.40 |
| 40 | | | | | |
| 41 OVERHEAD MARKUP: | | | | | |
| 42 Flat Rate Markup | Line 39 | 2,502.40 | % | 15.00 | 375.36 |
| 43 Material | Line 3 | 385.00 | % | | |
| 44 Major Quotations | Line 15 | 530.00 | % | | |
| 45 Sales Tax | Line 20 | 77.05 | % | | |
| 46 Direct Field Labor | Line 26 | 794.45 | % | | |
| 47 Direct Shop Labor | Line 27 | 0.00 | % | | |
| 48 Specialized Labor | Line 27 | 0.00 | % | | |
| 49 Indirect Labor | Line 27 | 0.00 | % | | |
| 50 Non-Productive Lbr. | Line 32 | 319.05 | % | | |
| 51 Direct Job Expenses | Line 37 | 396.85 | % | | |
| Sub Contracts | Line 38 | 0.00 | % | | |
| 53 JOB TOTAL | | | | | 2,877.76 |



NORMAN S. WRIGHT
CLIMATEC
MECHANICAL EQUIPMENT

2544 E. Miraloma Way, Anaheim, CA 92806-1608
13031 Bradley Avenue Sylmar, CA 91342-3832

tel 714.632.9800 fax 714.632.6900
tel 818.367.6100 fax 818.367.1221

Air Handlers-Air Distribution-Air Doors-Gas Chillers-Dampers/Louvers-Energy Recovery-Fvap Cooling-Fans/Ventilators-Fan Coils-Gas/Smoke Detection Humidification-Infrared Heaters-Lab Control
Valves-Kitchen Ventilation-Heating and Make-up Air-Sound Attenuation-Underfloor Air Distribution-VFD-Vehicle Exhaust-Water Source Heat Pumps

Page 1 of 2

Equipment Proposal

Quote # 91541 RFI 79 Rev 1

To: Sheldon Mechanical Corporation
Att: Dillon Boute
By: Mike Kline

Job: Lemonwood K-8 Reconstruction
Loc: Oxnard, CA
Eng: OED
Bid Date: 12-19-2016 RFI 79 Rev 1
Plan Date: 08-31-2016

NORMAN S WRIGHT CLIMATEC MECHANICAL EQUIPMENT OF SOUTHERN CALIFORNIA IS PLEASED TO OFFER THE FOLLOWING FOR YOUR CONSIDERATION

- | | | |
|---|---|-----------------|
| 2 | <u>Price industries Air Distribution</u> Model 530 steel construction, square neck, louvered Transfer bar grilles, surface mount application. Standard factory white finish. | \$100.00 |
| 1 | <u>Greenheck Fire Smoke Damper</u> Model FSD-212 Class II combination fire smoke damper, 1 1/2 hour rating, 3-V style blades, RRL/OCI resettable link with balde position switches, momentary test switch 16-inch sleeve length / 20-gauge sleeve thickness, retaining angles | \$430.00 |



F.O.B. factory / FFA

Due to recent volatility in raw material prices, unless quote is accepted within 30 days, and released for shipment within 90 days, prices are subject to change.

All quotations based on best available information and subject to the following:

Consignee is responsible for all freight claims. All prior to delivery calls are subject to a surcharge by the freight carrier. All orders entered by NSWC So Cal subject to cancellation charges. All agreements are subject to strikes, accidents, or other causes beyond our control. All quotations subject to corrections of clerical or math errors. Acceptance of each order is subject to approval of NSWC So Cal credit department, and customer acceptance of NSWC SO Cal terms of payment. Payment for partial shipment is due on the basis of invoice dates covering them. Every order is subject to any Federal, State, County, or Local Excise sales or use taxes. Quotations are for prompt acceptance only, and prices are subject to change without notice.



2200 Carnegie Court.
Oxnard, CA. 93033

Lemonwood K-8 School LLB
16055106

Request For Information # 00079

| | | | |
|------------|----------------------|-----------------------|------------|
| To: | SVA ARCHITECTS, INC. | RFI Date: | 08/24/2016 |
| Attention: | Tom Bardwell | Date Due: | 08/31/2016 |
| CC: | Paul Vernier | RFI Type: | Mechanical |
| | Dick Jones | Priority: | |
| | Huy Le | Schedule/Activity ID: | |
| | Kevin Krueger | Document Reference: | M1-11.1.A |
| | | Spec Section: | |
| | | Status: | Returned |

Subject: Water Heater Combustion Air Duct and Louver

INFORMATION REQUESTED:

Requested By: Nalani Scanlon

The 16x10 Louver at 8'-3" to 9'-1" will not work as shown on the attached M1-11.1.A and A1-31.2 Sketch. The space between the 8'-0" and 9'-0" ceiling structures do not allow enough room for constructability and louver frame allowance. Ceiling grill is not specified.

SUGGESTION:

Possible Cost Impact: Potentially

Possible Time Impact: Potentially

ANSWER:

Answered By: Tom Bardwell

Date of Response: 08/31/2016

Please see attached sketch for the location of the louver. Also see cut sheet and product data for Ceiling Grill.

ATTACHMENTS:

SKM_C224e16082416540
WATER HEATER COMBUSTION AIR DUCT AND LOUVER
ceiling grill cut sheet
Performance data - ceiling grill

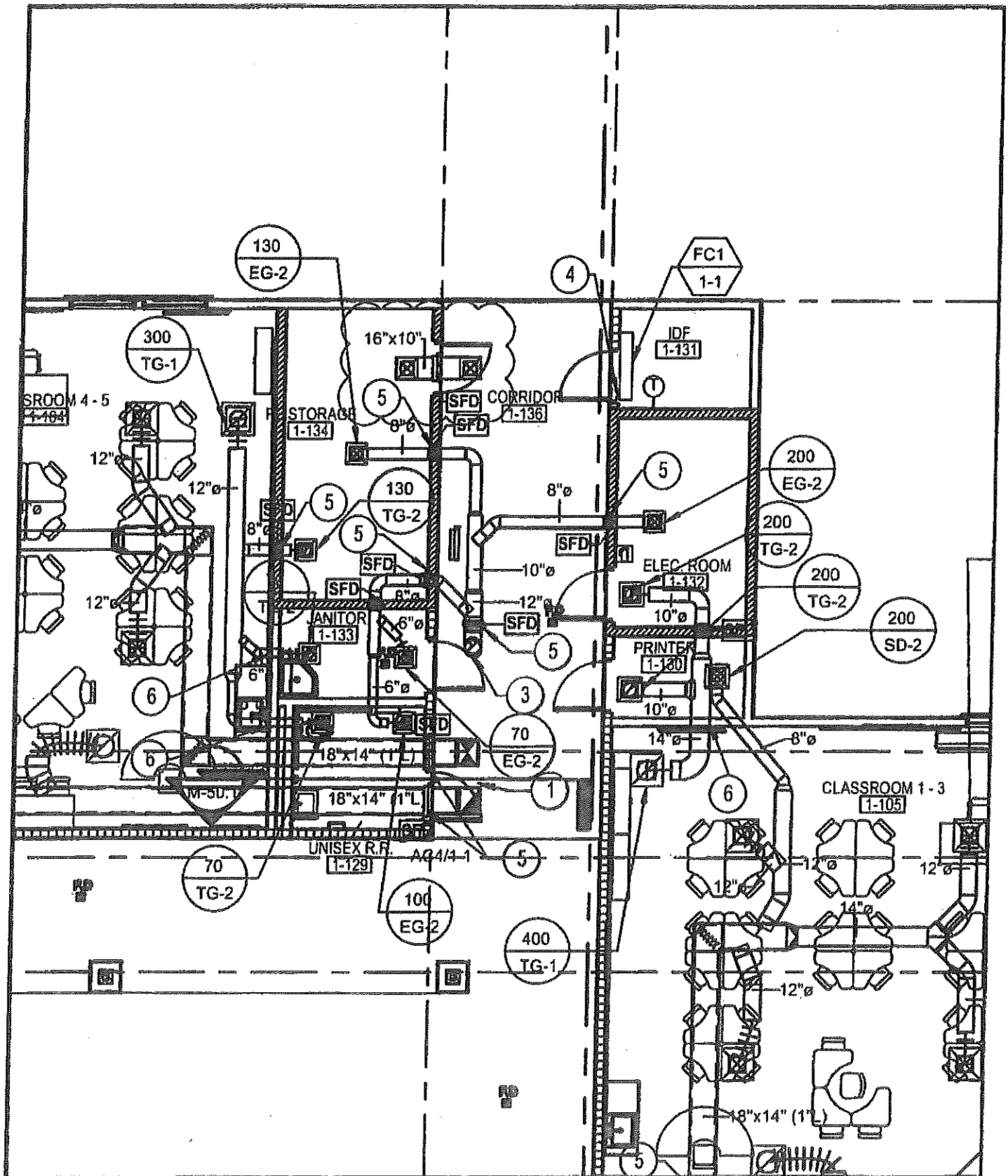

| | | | |
|--|--|---------------------------------------|--|
| | DESCRIPTION: WATER HEATER COMBUSTION AIR DUCT AND LOUVER | DRAWING REFERENCE: M1-11.1A | SKC #: SKC-1 |
| | PROJECT NAME: LEMONWOOD K-8 RECONSTRUCTION PROJECT NUMBER: 1340121 | ISSUE REFERENCE: RFI NO. 00079 | DATE: 08/31/2016 SCALE: 1/8" = 1'-0" DRAWN BY: Author |

11 SUPPLY GRILLES

80, 880, 4880, 800 Series | Supply

80, 580, 880, 5880 Dimensional Information

80, 580, FACE VIEW, SIDE VIEW, & CROSS SECTION

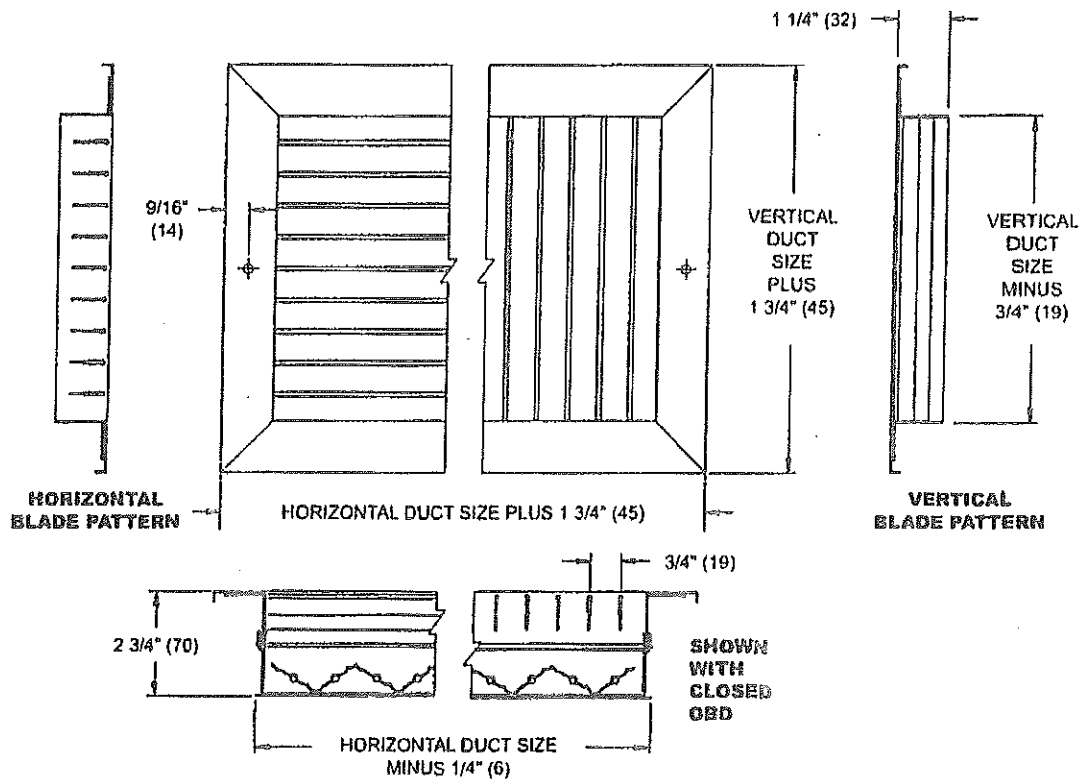

880, 5880, FACE VIEW, SIDE VIEW, & CROSS SECTION

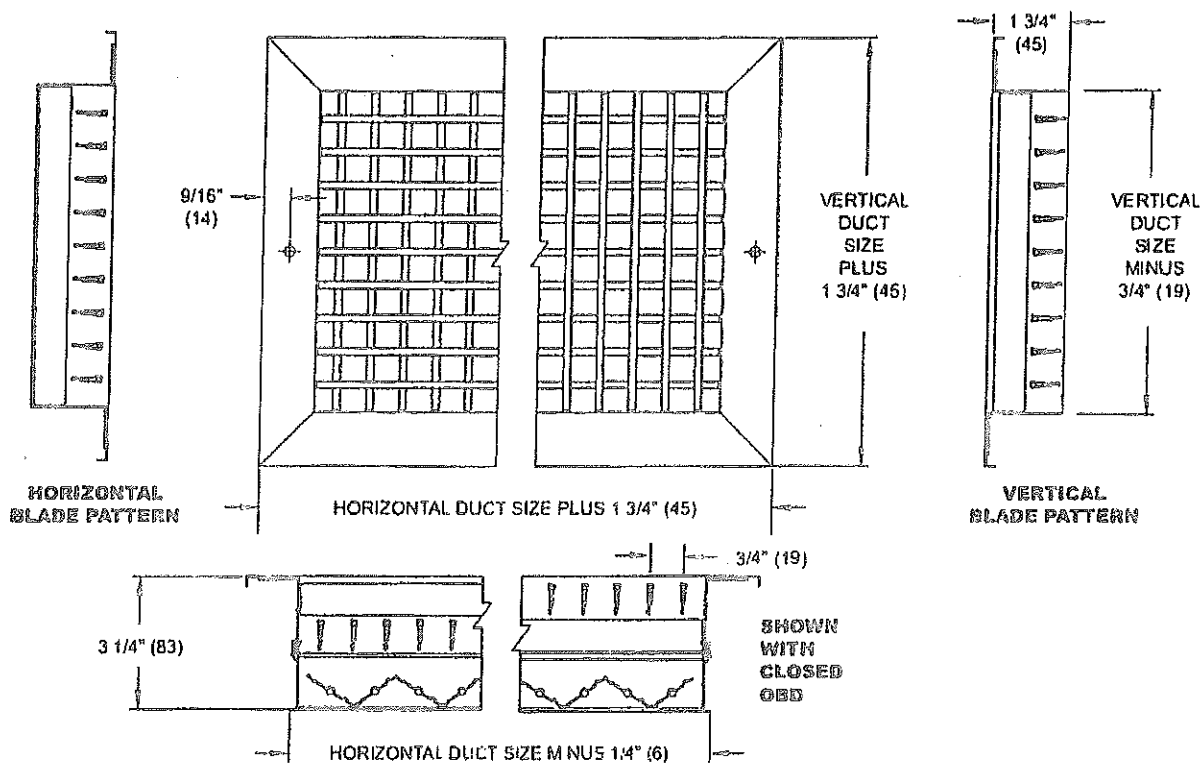

NOTE: Dimensions in parentheses are mm.

80, 880, 4880, 800 Series | Supply

80, 880, 4880, 800 Series Performance Data: Horizontal Throw

IP DATA: 80, 580, 880, 5880, 585, 5885, 480, 4880, 800, 5800 (WITH OBD/MULTILOUVER)

SUPPLY GRILLES

| Nom Duct | Duct Area | Neck Vel | Air Flow | 0° | | 22.5° | | 45° | | NC | Octave Band, dB | | | | | | |
|-----------|-----------|----------|----------|------|--------------|-------|--------------|------|--------------|----|-----------------|----|----|----|----|----|--|
| | | | | Pt | Throw | Pt | Throw | Pt | Throw | | 2 | 3 | 4 | 5 | 6 | 7 | |
| | | | | "WG | ft | "WG | ft | "WG | ft | | | | | | | | |
| 6" x 6" | 0.25 | 400 | 77 | .027 | 7 - 10 - 16 | .037 | 5 - 8 - 12 | .047 | 3 - 4 - 7 | - | 31 | 20 | 21 | - | - | - | |
| | | 650 | 124 | .071 | 11 - 15 - 21 | .098 | 8 - 11 - 16 | .125 | 5 - 7 - 9 | 18 | 43 | 33 | 34 | 25 | 15 | - | |
| | | 900 | 172 | .137 | 14 - 17 - 24 | .188 | 11 - 13 - 19 | .239 | 6 - 8 - 11 | 28 | 50 | 42 | 43 | 37 | 31 | 26 | |
| | | 1150 | 220 | .223 | 16 - 19 - 27 | .307 | 12 - 15 - 21 | .391 | 7 - 9 - 12 | 35 | 56 | 49 | 49 | 46 | 43 | 39 | |
| | | 1400 | 268 | .331 | 17 - 21 - 30 | .455 | 13 - 16 - 23 | .579 | 8 - 10 - 14 | 41 | 60 | 54 | 54 | 54 | 53 | 49 | |
| 8" x 6" | 0.33 | 400 | 106 | .027 | 8 - 12 - 19 | .037 | 6 - 9 - 15 | .047 | 4 - 5 - 9 | - | 33 | 21 | 22 | - | - | - | |
| | | 650 | 172 | .071 | 13 - 17 - 24 | .098 | 10 - 13 - 19 | .125 | 6 - 8 - 11 | 19 | 44 | 34 | 35 | 26 | 17 | 11 | |
| | | 900 | 238 | .137 | 16 - 20 - 28 | .188 | 13 - 16 - 22 | .239 | 7 - 9 - 13 | 29 | 52 | 43 | 44 | 39 | 33 | 28 | |
| | | 1150 | 304 | .223 | 19 - 23 - 32 | .307 | 14 - 18 - 25 | .391 | 8 - 10 - 14 | 36 | 57 | 50 | 51 | 48 | 45 | 40 | |
| | | 1400 | 370 | .331 | 20 - 25 - 35 | .455 | 16 - 19 - 27 | .579 | 9 - 11 - 16 | 42 | 62 | 55 | 56 | 55 | 55 | 50 | |
| 10" x 6" | 0.42 | 400 | 135 | .027 | 9 - 13 - 21 | .037 | 7 - 10 - 17 | .047 | 4 - 6 - 10 | - | 34 | 22 | 23 | - | - | - | |
| | | 650 | 219 | .071 | 14 - 19 - 27 | .098 | 11 - 15 - 21 | .125 | 6 - 9 - 12 | 20 | 45 | 35 | 36 | 27 | 18 | 12 | |
| | | 900 | 304 | .137 | 18 - 23 - 32 | .188 | 14 - 18 - 25 | .239 | 8 - 10 - 14 | 30 | 53 | 44 | 45 | 40 | 34 | 29 | |
| | | 1150 | 388 | .223 | 21 - 26 - 36 | .307 | 16 - 20 - 28 | .391 | 9 - 12 - 16 | 37 | 58 | 51 | 52 | 49 | 46 | 41 | |
| | | 1400 | 472 | .331 | 23 - 28 - 40 | .455 | 18 - 22 - 31 | .579 | 10 - 13 - 18 | 43 | 63 | 56 | 57 | 56 | 56 | 51 | |
| 8" x 8" | 0.44 | 400 | 146 | .027 | 9 - 14 - 22 | .037 | 7 - 11 - 17 | .047 | 4 - 6 - 10 | - | 34 | 22 | 24 | - | - | - | |
| | | 650 | 237 | .071 | 15 - 20 - 28 | .098 | 12 - 16 - 22 | .125 | 7 - 9 - 13 | 21 | 45 | 36 | 37 | 28 | 18 | 13 | |
| | | 900 | 329 | .137 | 19 - 24 - 33 | .188 | 15 - 18 - 26 | .239 | 9 - 11 - 15 | 30 | 53 | 45 | 45 | 40 | 34 | 29 | |
| | | 1150 | 420 | .223 | 22 - 27 - 38 | .307 | 17 - 21 - 29 | .391 | 10 - 12 - 17 | 38 | 59 | 51 | 52 | 49 | 46 | 42 | |
| | | 1400 | 511 | .331 | 24 - 29 - 42 | .455 | 19 - 23 - 32 | .579 | 11 - 13 - 19 | 44 | 63 | 57 | 57 | 57 | 56 | 51 | |
| 12" x 6" | 0.50 | 400 | 164 | .027 | 10 - 15 - 24 | .037 | 8 - 11 - 18 | .047 | 4 - 7 - 11 | - | 35 | 23 | 24 | - | - | - | |
| | | 650 | 267 | .071 | 16 - 21 - 30 | .098 | 12 - 16 - 23 | .125 | 7 - 10 - 14 | 21 | 46 | 36 | 37 | 28 | 19 | 13 | |
| | | 900 | 369 | .137 | 20 - 25 - 35 | .188 | 16 - 19 - 27 | .239 | 9 - 11 - 16 | 31 | 53 | 45 | 46 | 40 | 35 | 30 | |
| | | 1150 | 472 | .223 | 23 - 28 - 40 | .307 | 18 - 22 - 31 | .391 | 10 - 13 - 18 | 38 | 59 | 52 | 53 | 50 | 47 | 42 | |
| | | 1400 | 574 | .331 | 25 - 31 - 44 | .455 | 20 - 24 - 34 | .579 | 11 - 14 - 20 | 44 | 64 | 57 | 58 | 57 | 56 | 52 | |
| 14" x 6" | 0.58 | 400 | 193 | .027 | 11 - 16 - 26 | .037 | 8 - 12 - 20 | .047 | 5 - 7 - 12 | - | 35 | 24 | 25 | 11 | - | - | |
| | | 650 | 314 | .071 | 17 - 23 - 33 | .098 | 13 - 18 - 25 | .125 | 8 - 10 - 15 | 22 | 47 | 37 | 38 | 29 | 19 | 14 | |
| | | 900 | 435 | .137 | 22 - 27 - 38 | .188 | 17 - 21 - 30 | .239 | 10 - 12 - 17 | 31 | 54 | 46 | 47 | 41 | 35 | 30 | |
| | | 1150 | 556 | .223 | 25 - 31 - 43 | .307 | 19 - 24 - 34 | .391 | 11 - 14 - 19 | 39 | 60 | 53 | 53 | 50 | 47 | 43 | |
| | | 1400 | 676 | .331 | 28 - 34 - 48 | .455 | 21 - 26 - 37 | .579 | 12 - 15 - 22 | 45 | 64 | 58 | 59 | 58 | 57 | 53 | |
| 12" x 8" | 0.67 | 400 | 227 | .027 | 11 - 17 - 28 | .037 | 9 - 13 - 21 | .047 | 5 - 8 - 12 | - | 36 | 24 | 25 | 11 | - | - | |
| | | 650 | 368 | .071 | 19 - 25 - 35 | .098 | 14 - 19 - 27 | .125 | 8 - 11 - 16 | 22 | 47 | 38 | 39 | 30 | 20 | 14 | |
| | | 900 | 510 | .137 | 24 - 29 - 42 | .188 | 19 - 23 - 32 | .239 | 11 - 13 - 19 | 32 | 55 | 47 | 47 | 42 | 36 | 31 | |
| | | 1150 | 651 | .223 | 27 - 33 - 47 | .307 | 21 - 26 - 36 | .391 | 12 - 15 - 21 | 39 | 61 | 53 | 54 | 51 | 48 | 43 | |
| | | 1400 | 793 | .331 | 30 - 37 - 52 | .455 | 23 - 28 - 40 | .579 | 13 - 16 - 23 | 45 | 65 | 59 | 59 | 59 | 58 | 53 | |
| 10" x 10" | 0.69 | 400 | 238 | .027 | 12 - 18 - 28 | .037 | 9 - 14 - 22 | .047 | 5 - 8 - 13 | - | 36 | 24 | 26 | 12 | - | - | |
| | | 650 | 386 | .071 | 19 - 26 - 36 | .098 | 15 - 20 - 28 | .125 | 9 - 11 - 16 | 23 | 47 | 38 | 39 | 30 | 20 | 15 | |
| | | 900 | 535 | .137 | 25 - 30 - 43 | .188 | 19 - 23 - 33 | .239 | 11 - 14 - 19 | 32 | 55 | 47 | 48 | 42 | 36 | 31 | |
| | | 1150 | 683 | .223 | 28 - 34 - 48 | .307 | 22 - 26 - 37 | .391 | 12 - 15 - 22 | 40 | 61 | 53 | 54 | 51 | 48 | 44 | |
| | | 1400 | 832 | .331 | 31 - 37 - 53 | .455 | 24 - 29 - 41 | .579 | 14 - 17 - 24 | 46 | 65 | 59 | 59 | 59 | 58 | 54 | |
| 18" x 6" | 0.75 | 400 | 252 | .027 | 12 - 18 - 29 | .037 | 9 - 14 - 23 | .047 | 5 - 8 - 13 | - | 36 | 25 | 26 | 12 | - | - | |
| | | 650 | 409 | .071 | 20 - 26 - 37 | .098 | 15 - 20 - 29 | .125 | 9 - 12 - 17 | 23 | 48 | 38 | 39 | 30 | 20 | 15 | |
| | | 900 | 566 | .137 | 25 - 31 - 44 | .188 | 20 - 24 - 34 | .239 | 11 - 14 - 20 | 33 | 55 | 47 | 48 | 42 | 37 | 31 | |
| | | 1150 | 723 | .223 | 29 - 35 - 49 | .307 | 22 - 27 - 38 | .391 | 13 - 16 - 22 | 40 | 61 | 54 | 54 | 52 | 49 | 44 | |
| | | 1400 | 880 | .331 | 31 - 39 - 55 | .455 | 24 - 30 - 42 | .579 | 14 - 17 - 25 | 46 | 66 | 59 | 60 | 59 | 58 | 54 | |
| 12" x 10" | 0.83 | 300 | 217 | .015 | 9 - 15 - 27 | .021 | 7 - 11 - 21 | .027 | 4 - 7 - 12 | - | 30 | 17 | 19 | - | - | - | |
| | | 550 | 397 | .051 | 18 - 26 - 37 | .070 | 14 - 20 - 28 | .089 | 8 - 12 - 16 | 18 | 44 | 34 | 35 | 24 | 13 | - | |
| | | 800 | 578 | .108 | 26 - 31 - 44 | .149 | 20 - 24 - 34 | .189 | 11 - 14 - 20 | 30 | 53 | 44 | 45 | 38 | 31 | 26 | |
| | | 1050 | 759 | .186 | 29 - 36 - 51 | .256 | 23 - 28 - 39 | .326 | 13 - 16 - 23 | 38 | 60 | 52 | 53 | 49 | 45 | 40 | |
| | | 1300 | 939 | .285 | 33 - 40 - 56 | .392 | 25 - 31 - 44 | .499 | 15 - 18 - 25 | 44 | 64 | 58 | 58 | 57 | 55 | 51 | |
| 22" x 6" | 0.92 | 300 | 232 | .015 | 9 - 15 - 28 | .021 | 7 - 12 - 22 | .027 | 4 - 7 - 13 | - | 31 | 18 | 19 | - | - | - | |
| | | 550 | 426 | .051 | 18 - 27 - 38 | .070 | 14 - 21 - 29 | .089 | 8 - 12 - 17 | 19 | 45 | 34 | 35 | 25 | 13 | - | |
| | | 800 | 620 | .108 | 26 - 32 - 46 | .149 | 20 - 25 - 35 | .189 | 12 - 15 - 21 | 30 | 53 | 45 | 45 | 39 | 32 | 26 | |
| | | 1050 | 813 | .186 | 30 - 37 - 52 | .256 | 23 - 29 - 41 | .326 | 14 - 17 - 24 | 38 | 60 | 52 | 53 | 49 | 45 | 40 | |
| | | 1300 | 1007 | .285 | 34 - 41 - 58 | .392 | 26 - 32 - 45 | .499 | 15 - 19 - 26 | 44 | 65 | 58 | 59 | 57 | 56 | 51 | |

NOTE: See notes on page I1-37.

80, 880, 4880, 800 Series Performance Data: Horizontal Throw
IP DATA: 80, 580, 880, 5880, 585, 5885, 480, 4880, 800, 5800 (WITH OBD/MULTILOUVER)

| Nom Duct | Duct Area | Neck Vel | Air Flow | 0° | | 22.5° | | 45° | | NC | Octave Band, dB | | | | | | |
|-----------|-----------|----------|----------|------|--------------|-------|--------------|------|--------------|----|-----------------|----|----|----|----|----|--|
| | | | | Pt | Throw | Pt | Throw | Pt | Throw | | 2 | 3 | 4 | 5 | 6 | 7 | |
| | | | | "WG | ft | "WG | ft | "WG | ft | | | | | | | | |
| 12" x 12" | 1.00 | 300 | 264 | .015 | 10 - 16 - 30 | .021 | 8 - 12 - 23 | .027 | 4 - 7 - 13 | - | 31 | 18 | 20 | - | - | - | |
| | | 550 | 483 | .051 | 20 - 29 - 40 | .070 | 15 - 22 - 31 | .089 | 9 - 13 - 18 | 19 | 45 | 35 | 36 | 25 | 14 | - | |
| | | 800 | 703 | .108 | 28 - 34 - 49 | .149 | 22 - 27 - 38 | .189 | 13 - 16 - 22 | 30 | 54 | 45 | 46 | 39 | 32 | 27 | |
| | | 1050 | 923 | .186 | 32 - 39 - 56 | .256 | 25 - 31 - 43 | .326 | 15 - 18 - 25 | 39 | 60 | 53 | 53 | 50 | 46 | 41 | |
| | | 1300 | 1143 | .285 | 36 - 44 - 62 | .392 | 28 - 34 - 48 | .499 | 16 - 20 - 28 | 45 | 65 | 59 | 59 | 58 | 56 | 52 | |
| 18" x 10" | 1.25 | 300 | 332 | .015 | 11 - 18 - 34 | .021 | 9 - 14 - 26 | .027 | 5 - 8 - 15 | - | 32 | 19 | 21 | - | - | - | |
| | | 525 | 582 | .047 | 21 - 31 - 44 | .064 | 16 - 24 - 34 | .081 | 9 - 14 - 20 | 19 | 45 | 35 | 36 | 24 | 12 | - | |
| | | 750 | 831 | .095 | 30 - 37 - 53 | .131 | 23 - 29 - 41 | .166 | 13 - 17 - 24 | 30 | 54 | 44 | 45 | 38 | 30 | 25 | |
| | | 975 | 1080 | .161 | 35 - 43 - 60 | .221 | 27 - 33 - 47 | .281 | 16 - 19 - 27 | 37 | 60 | 52 | 52 | 48 | 43 | 38 | |
| | | 1200 | 1330 | .243 | 39 - 47 - 67 | .334 | 30 - 37 - 52 | .425 | 17 - 21 - 30 | 44 | 64 | 57 | 58 | 56 | 53 | 48 | |
| 14" x 14" | 1.36 | 300 | 366 | .015 | 12 - 19 - 35 | .021 | 9 - 15 - 27 | .027 | 5 - 8 - 16 | - | 33 | 20 | 21 | - | - | - | |
| | | 525 | 640 | .047 | 22 - 33 - 47 | .064 | 17 - 25 - 36 | .081 | 10 - 15 - 21 | 19 | 46 | 35 | 36 | 25 | 13 | - | |
| | | 750 | 914 | .095 | 31 - 39 - 56 | .131 | 24 - 30 - 43 | .166 | 14 - 18 - 26 | 30 | 54 | 45 | 46 | 38 | 30 | 25 | |
| | | 975 | 1189 | .161 | 37 - 45 - 63 | .221 | 28 - 35 - 49 | .281 | 16 - 20 - 29 | 38 | 60 | 52 | 53 | 48 | 43 | 38 | |
| | | 1200 | 1463 | .243 | 41 - 50 - 70 | .334 | 31 - 39 - 54 | .425 | 18 - 22 - 32 | 44 | 65 | 58 | 58 | 56 | 54 | 49 | |
| 27" x 8" | 1.50 | 300 | 396 | .015 | 12 - 20 - 37 | .021 | 9 - 15 - 28 | .027 | 6 - 9 - 16 | - | 33 | 20 | 21 | - | - | - | |
| | | 525 | 694 | .047 | 23 - 34 - 48 | .064 | 18 - 27 - 38 | .081 | 10 - 15 - 22 | 20 | 46 | 35 | 36 | 25 | 13 | - | |
| | | 750 | 991 | .095 | 33 - 41 - 58 | .131 | 25 - 32 - 45 | .166 | 15 - 18 - 26 | 30 | 54 | 45 | 46 | 39 | 31 | 25 | |
| | | 975 | 1289 | .161 | 38 - 47 - 66 | .221 | 30 - 36 - 51 | .281 | 17 - 21 - 30 | 38 | 60 | 52 | 53 | 49 | 44 | 39 | |
| | | 1200 | 1586 | .243 | 42 - 52 - 73 | .334 | 33 - 40 - 57 | .425 | 19 - 23 - 33 | 44 | 65 | 58 | 59 | 56 | 54 | 49 | |
| 22" x 10" | 1.53 | 300 | 410 | .015 | 12 - 20 - 37 | .021 | 10 - 15 - 29 | .027 | 6 - 9 - 17 | - | 33 | 20 | 21 | - | - | - | |
| | | 525 | 717 | .047 | 23 - 35 - 49 | .064 | 18 - 27 - 38 | .081 | 10 - 16 - 22 | 20 | 46 | 36 | 37 | 25 | 13 | - | |
| | | 750 | 1024 | .095 | 33 - 42 - 59 | .131 | 26 - 32 - 46 | .166 | 15 - 19 - 26 | 30 | 54 | 45 | 46 | 39 | 31 | 26 | |
| | | 975 | 1331 | .161 | 39 - 47 - 67 | .221 | 30 - 37 - 52 | .281 | 17 - 21 - 30 | 38 | 61 | 53 | 53 | 49 | 44 | 39 | |
| | | 1200 | 1638 | .243 | 43 - 53 - 74 | .334 | 33 - 41 - 58 | .425 | 19 - 24 - 33 | 44 | 65 | 58 | 59 | 57 | 54 | 49 | |
| 24" x 10" | 1.67 | 300 | 448 | .015 | 13 - 21 - 39 | .021 | 10 - 16 - 30 | .027 | 6 - 9 - 18 | - | 33 | 21 | 22 | - | - | - | |
| | | 475 | 709 | .038 | 22 - 33 - 49 | .052 | 17 - 26 - 38 | .067 | 10 - 15 - 22 | 17 | 44 | 33 | 34 | 22 | - | - | |
| | | 650 | 971 | .071 | 30 - 41 - 57 | .098 | 23 - 31 - 44 | .125 | 14 - 18 - 26 | 26 | 51 | 42 | 43 | 34 | 24 | 19 | |
| | | 825 | 1232 | .115 | 37 - 46 - 65 | .158 | 29 - 35 - 50 | .201 | 17 - 21 - 29 | 34 | 57 | 48 | 49 | 43 | 36 | 31 | |
| | | 1000 | 1493 | .169 | 41 - 50 - 71 | .232 | 32 - 39 - 55 | .295 | 18 - 23 - 32 | 39 | 62 | 54 | 54 | 50 | 45 | 41 | |
| 18" x 14" | 1.75 | 300 | 476 | .015 | 13 - 22 - 40 | .021 | 10 - 17 - 31 | .027 | 6 - 10 - 18 | - | 34 | 21 | 22 | - | - | - | |
| | | 475 | 754 | .038 | 23 - 34 - 50 | .052 | 18 - 26 - 39 | .067 | 10 - 15 - 23 | 17 | 44 | 33 | 35 | 22 | - | - | |
| | | 650 | 1032 | .071 | 31 - 42 - 59 | .098 | 24 - 32 - 46 | .125 | 14 - 19 - 27 | 27 | 52 | 42 | 43 | 34 | 24 | 19 | |
| | | 825 | 1309 | .115 | 38 - 47 - 67 | .158 | 30 - 36 - 52 | .201 | 17 - 21 - 30 | 34 | 57 | 49 | 49 | 43 | 36 | 31 | |
| | | 1000 | 1587 | .169 | 42 - 52 - 73 | .232 | 33 - 40 - 57 | .295 | 19 - 23 - 33 | 40 | 62 | 54 | 55 | 50 | 46 | 41 | |
| 16" x 16" | 1.78 | 300 | 485 | .015 | 14 - 22 - 40 | .021 | 10 - 17 - 31 | .027 | 6 - 10 - 18 | - | 34 | 21 | 22 | - | - | - | |
| | | 475 | 767 | .038 | 23 - 34 - 51 | .052 | 18 - 27 - 39 | .067 | 10 - 15 - 23 | 17 | 45 | 34 | 35 | 22 | - | - | |
| | | 650 | 1050 | .071 | 31 - 42 - 60 | .098 | 24 - 33 - 46 | .125 | 14 - 19 - 27 | 27 | 52 | 42 | 43 | 34 | 25 | 19 | |
| | | 825 | 1332 | .115 | 39 - 47 - 67 | .158 | 30 - 37 - 52 | .201 | 17 - 21 - 30 | 34 | 57 | 49 | 49 | 43 | 36 | 31 | |
| | | 1000 | 1615 | .169 | 43 - 52 - 74 | .232 | 33 - 40 - 57 | .295 | 19 - 24 - 33 | 40 | 62 | 54 | 55 | 50 | 46 | 41 | |
| 24" x 12" | 2.00 | 300 | 545 | .015 | 14 - 23 - 43 | .021 | 11 - 18 - 33 | .027 | 6 - 10 - 19 | - | 34 | 21 | 23 | - | - | - | |
| | | 475 | 863 | .038 | 24 - 36 - 54 | .052 | 19 - 28 - 42 | .067 | 11 - 16 - 24 | 18 | 45 | 34 | 35 | 23 | - | - | |
| | | 650 | 1181 | .071 | 33 - 45 - 63 | .098 | 26 - 35 - 49 | .125 | 15 - 20 - 28 | 27 | 52 | 43 | 44 | 35 | 25 | 20 | |
| | | 825 | 1499 | .115 | 41 - 50 - 71 | .158 | 32 - 39 - 55 | .201 | 18 - 23 - 32 | 34 | 58 | 49 | 50 | 44 | 37 | 32 | |
| | | 1000 | 1816 | .169 | 45 - 55 - 78 | .232 | 35 - 43 - 61 | .295 | 20 - 25 - 35 | 40 | 62 | 54 | 55 | 51 | 46 | 41 | |
| 18" x 18" | 2.25 | 300 | 620 | .015 | 15 - 25 - 46 | .021 | 12 - 19 - 35 | .027 | 7 - 11 - 21 | - | 35 | 22 | 23 | - | - | - | |
| | | 475 | 982 | .038 | 26 - 39 - 58 | .052 | 20 - 30 - 45 | .067 | 12 - 18 - 26 | 18 | 46 | 35 | 36 | 23 | - | - | |
| | | 650 | 1343 | .071 | 35 - 48 - 67 | .098 | 28 - 37 - 52 | .125 | 16 - 21 - 30 | 28 | 53 | 43 | 44 | 35 | 26 | 20 | |
| | | 825 | 1705 | .115 | 44 - 54 - 76 | .158 | 34 - 42 - 59 | .201 | 20 - 24 - 34 | 35 | 58 | 50 | 51 | 44 | 37 | 32 | |
| | | 1000 | 2066 | .169 | 48 - 59 - 84 | .232 | 37 - 46 - 65 | .295 | 22 - 27 - 38 | 41 | 63 | 55 | 56 | 51 | 47 | 42 | |
| 24" x 14" | 2.33 | 300 | 642 | .015 | 16 - 25 - 47 | .021 | 12 - 19 - 36 | .027 | 7 - 11 - 21 | - | 35 | 22 | 23 | - | - | - | |
| | | 475 | 1016 | .038 | 26 - 40 - 59 | .052 | 20 - 31 - 45 | .067 | 12 - 18 - 26 | 19 | 46 | 35 | 36 | 24 | - | - | |
| | | 650 | 1391 | .071 | 36 - 48 - 69 | .098 | 28 - 38 - 53 | .125 | 16 - 22 - 31 | 28 | 53 | 43 | 44 | 35 | 26 | 20 | |
| | | 825 | 1765 | .115 | 45 - 55 - 77 | .158 | 35 - 42 - 60 | .201 | 20 - 25 - 35 | 35 | 59 | 50 | 51 | 44 | 38 | 32 | |
| | | 1000 | 2139 | .169 | 49 - 60 - 85 | .232 | 38 - 47 - 66 | .295 | 22 - 27 - 38 | 41 | 63 | 55 | 56 | 52 | 47 | 42 | |

SUPPLY GRILLES

H O S T I N G S O L U T I O N S

NOTE: See notes on page I1-37.

80, 880, 4880, 800 Series | Supply

80, 880, 4880, 800 Series Performance Data: Horizontal Throw

IP DATA: 80, 580, 880, 5880, 585, 5885, 480, 4880, 800, 5800 (WITH OBD/MULTILOUVER)

| Nom Duct | Duct Area | Neck Vel | Air Flow | 0° | | 22.5° | | 45° | | NC | Octave Band, dB | | | | | | |
|-----------|-----------|----------|----------|------|-----------|-------|----------|------|----------|----|-----------------|----|----|----|----|----|-----|
| | | | | Pt | Throw | Pt | Throw | Pt | Throw | | 2 | 3 | 4 | 5 | 6 | 7 | |
| | | | | | | | | | | | | | | | | | "WG |
| in | ft² | FPM | CFM | "WG | ft | "WG | ft | "WG | ft | | | | | | | | |
| 30" x 12" | 2.50 | 300 | 686 | .015 | 16-26-48 | .021 | 12-20-37 | .027 | 7-12-22 | - | 35 | 22 | 24 | - | - | - | |
| | | 475 | 1085 | .038 | 27-41-61 | .052 | 21-32-47 | .067 | 12-18-27 | 19 | 46 | 35 | 36 | 24 | 11 | - | |
| | | 650 | 1485 | .071 | 37-50-71 | .098 | 29-39-55 | .125 | 17-23-32 | 28 | 53 | 44 | 45 | 36 | 26 | 21 | |
| | | 825 | 1885 | .115 | 46-56-80 | .158 | 36-44-62 | .201 | 21-25-36 | 35 | 59 | 50 | 51 | 45 | 38 | 33 | |
| | | 1000 | 2285 | .169 | 51-62-88 | .232 | 39-48-68 | .295 | 23-28-40 | 41 | 63 | 55 | 56 | 52 | 47 | 42 | |
| 24" x 16" | 2.67 | 300 | 739 | .015 | 17-27-50 | .021 | 13-21-39 | .027 | 8-12-22 | - | 36 | 23 | 24 | - | - | - | |
| | | 475 | 1170 | .038 | 28-42-63 | .052 | 22-33-49 | .067 | 13-19-28 | 19 | 46 | 35 | 36 | 24 | 11 | - | |
| | | 650 | 1600 | .071 | 39-52-74 | .098 | 30-40-57 | .125 | 17-23-33 | 29 | 54 | 44 | 45 | 36 | 26 | 21 | |
| | | 825 | 2031 | .115 | 48-59-83 | .158 | 37-45-64 | .201 | 22-26-37 | 36 | 59 | 51 | 51 | 45 | 38 | 33 | |
| | | 1000 | 2462 | .169 | 53-65-91 | .232 | 41-50-71 | .295 | 24-29-41 | 41 | 64 | 56 | 57 | 52 | 48 | 43 | |
| 20" x 20" | 2.76 | 300 | 772 | .015 | 17-27-51 | .021 | 13-21-40 | .027 | 8-12-23 | - | 35 | 23 | 24 | - | - | - | |
| | | 475 | 1222 | .038 | 29-43-64 | .052 | 22-34-50 | .067 | 13-20-29 | 19 | 47 | 36 | 37 | 24 | 11 | - | |
| | | 650 | 1673 | .071 | 40-53-75 | .098 | 31-41-58 | .125 | 18-24-34 | 29 | 54 | 44 | 45 | 36 | 27 | 21 | |
| | | 825 | 2123 | .115 | 49-60-85 | .158 | 38-46-66 | .201 | 22-27-38 | 36 | 59 | 51 | 52 | 45 | 38 | 33 | |
| | | 1000 | 2573 | .169 | 54-66-93 | .232 | 42-51-72 | .295 | 24-30-42 | 42 | 64 | 56 | 57 | 52 | 48 | 43 | |
| 24" x 18" | 3.00 | 300 | 836 | .015 | 18-29-53 | .021 | 14-22-41 | .027 | 8-13-24 | - | 36 | 23 | 25 | - | - | - | |
| | | 475 | 1323 | .038 | 30-45-67 | .052 | 23-35-52 | .067 | 14-20-30 | 20 | 47 | 36 | 37 | 25 | 11 | - | |
| | | 650 | 1810 | .071 | 41-55-78 | .098 | 32-43-61 | .125 | 19-25-35 | 29 | 54 | 44 | 45 | 37 | 27 | 21 | |
| | | 825 | 2298 | .115 | 51-62-88 | .158 | 39-48-68 | .201 | 23-28-40 | 36 | 60 | 51 | 52 | 46 | 39 | 33 | |
| | | 1000 | 2785 | .169 | 56-69-97 | .232 | 43-53-75 | .295 | 25-31-44 | 42 | 64 | 56 | 57 | 53 | 48 | 43 | |
| 30" x 16" | 3.33 | 300 | 929 | .015 | 19-30-56 | .021 | 15-23-43 | .027 | 8-14-25 | - | 37 | 24 | 25 | - | - | - | |
| | | 475 | 1471 | .038 | 32-48-71 | .052 | 25-37-55 | .067 | 14-21-32 | 20 | 47 | 36 | 37 | 25 | 12 | - | |
| | | 650 | 2013 | .071 | 43-58-82 | .098 | 34-45-64 | .125 | 20-26-37 | 30 | 55 | 45 | 46 | 37 | 27 | 22 | |
| | | 825 | 2556 | .115 | 54-66-93 | .158 | 42-51-72 | .201 | 24-30-42 | 37 | 60 | 52 | 52 | 46 | 39 | 34 | |
| | | 1000 | 3098 | .169 | 59-72-102 | .232 | 46-56-79 | .295 | 27-33-46 | 42 | 65 | 57 | 58 | 53 | 49 | 44 | |
| 22" x 22" | 3.36 | 300 | 941 | .015 | 19-30-56 | .021 | 15-23-44 | .027 | 8-14-25 | - | 37 | 24 | 25 | - | - | - | |
| | | 475 | 1490 | .038 | 32-48-71 | .052 | 25-37-55 | .067 | 14-22-32 | 20 | 47 | 36 | 37 | 25 | 12 | - | |
| | | 650 | 2038 | .071 | 44-59-83 | .098 | 34-45-64 | .125 | 20-26-37 | 30 | 55 | 45 | 46 | 37 | 27 | 22 | |
| | | 825 | 2587 | .115 | 54-66-94 | .158 | 42-51-72 | .201 | 24-30-42 | 37 | 60 | 52 | 52 | 46 | 39 | 34 | |
| | | 1000 | 3136 | .169 | 59-73-103 | .232 | 46-56-80 | .295 | 27-33-46 | 42 | 65 | 57 | 58 | 53 | 49 | 44 | |
| 36" x 14" | 3.50 | 300 | 973 | .015 | 19-31-57 | .021 | 15-24-44 | .027 | 9-14-26 | - | 37 | 24 | 25 | - | - | - | |
| | | 475 | 1541 | .038 | 32-49-72 | .052 | 25-38-56 | .067 | 15-22-32 | 20 | 48 | 37 | 38 | 25 | 12 | - | |
| | | 650 | 2108 | .071 | 44-60-84 | .098 | 34-46-65 | .125 | 20-27-38 | 30 | 55 | 45 | 46 | 37 | 28 | 22 | |
| | | 825 | 2676 | .115 | 55-67-95 | .158 | 43-52-74 | .201 | 25-30-43 | 37 | 60 | 52 | 53 | 46 | 39 | 34 | |
| | | 1000 | 3243 | .169 | 60-74-105 | .232 | 47-57-81 | .295 | 27-33-47 | 43 | 65 | 57 | 58 | 53 | 49 | 44 | |
| 24" x 22" | 3.67 | 300 | 1029 | .015 | 20-32-59 | .021 | 15-25-46 | .027 | 9-14-27 | - | 37 | 24 | 25 | - | - | - | |
| | | 450 | 1544 | .034 | 32-47-72 | .047 | 25-37-56 | .060 | 14-21-33 | 19 | 47 | 35 | 36 | 24 | - | - | |
| | | 600 | 2059 | .061 | 42-59-83 | .084 | 33-46-65 | .106 | 19-27-38 | 28 | 53 | 43 | 44 | 34 | 24 | 18 | |
| | | 750 | 2573 | .095 | 53-66-93 | .131 | 41-54-72 | .166 | 24-30-42 | 34 | 58 | 49 | 50 | 43 | 35 | 30 | |
| | | 900 | 3088 | .137 | 59-72-102 | .188 | 46-56-79 | .239 | 27-33-46 | 40 | 63 | 54 | 55 | 50 | 44 | 39 | |
| 30" x 18" | 3.75 | 300 | 1051 | .015 | 20-32-60 | .021 | 15-25-46 | .027 | 9-14-27 | - | 37 | 24 | 26 | - | - | - | |
| | | 450 | 1577 | .034 | 32-48-73 | .047 | 25-37-57 | .060 | 14-22-33 | 19 | 47 | 35 | 37 | 24 | - | - | |
| | | 600 | 2102 | .061 | 43-60-84 | .084 | 33-46-65 | .106 | 19-27-38 | 28 | 53 | 43 | 44 | 35 | 24 | 18 | |
| | | 750 | 2628 | .095 | 53-67-94 | .131 | 41-52-73 | .166 | 24-30-42 | 34 | 59 | 49 | 50 | 43 | 35 | 30 | |
| | | 900 | 3154 | .137 | 60-73-103 | .188 | 46-57-80 | .239 | 27-33-46 | 40 | 63 | 54 | 55 | 50 | 44 | 39 | |
| 36" x 16" | 4.00 | 300 | 1120 | .015 | 21-33-62 | .021 | 16-26-48 | .027 | 9-15-28 | - | 37 | 25 | 26 | - | - | - | |
| | | 450 | 1680 | .034 | 33-50-75 | .047 | 26-38-58 | .060 | 15-22-34 | 19 | 47 | 36 | 37 | 24 | - | - | |
| | | 600 | 2240 | .061 | 44-62-87 | .084 | 34-48-67 | .106 | 20-28-39 | 28 | 54 | 44 | 45 | 35 | 24 | 19 | |
| | | 750 | 2800 | .095 | 55-69-97 | .131 | 43-53-75 | .166 | 25-31-44 | 35 | 59 | 50 | 51 | 43 | 35 | 30 | |
| | | 900 | 3360 | .137 | 62-75-107 | .188 | 48-58-83 | .239 | 28-34-48 | 40 | 63 | 55 | 55 | 50 | 44 | 39 | |
| 36" x 18" | 4.50 | 300 | 1267 | .015 | 22-35-65 | .021 | 17-27-51 | .027 | 10-16-29 | - | 38 | 25 | 26 | - | - | - | |
| | | 450 | 1900 | .034 | 35-53-80 | .047 | 27-41-62 | .060 | 16-24-36 | 20 | 47 | 36 | 37 | 24 | 11 | - | |
| | | 600 | 2534 | .061 | 47-65-93 | .084 | 36-51-72 | .106 | 21-29-42 | 28 | 54 | 44 | 45 | 35 | 25 | 19 | |
| | | 750 | 3167 | .095 | 59-73-103 | .131 | 45-57-80 | .166 | 26-33-47 | 35 | 59 | 50 | 51 | 44 | 36 | 30 | |
| | | 900 | 3800 | .137 | 65-80-113 | .188 | 51-62-88 | .239 | 29-36-51 | 41 | 64 | 55 | 56 | 51 | 45 | 40 | |

NOTE: See notes on page I1-37.

80, 880, 4880, 800 Series Performance Data: Horizontal Throw

IP DATA: 80, 580, 880, 5880, 585, 5885, 480, 4880, 800, 5800 (WITH OBD/MULTILOUVER)

| Nom Duct | Duct Area | Neck Vel | Air Flow | 0° | | 22.5° | | 45° | | NC | Octave Band, dB | | | | | | |
|-----------|-----------|----------|----------|------|----------------|-------|---------------|------|--------------|----|-----------------|----|----|----|----|----|--|
| | | | | Pt | Throw | PI | Throw | Pt | Throw | | 2 | 3 | 4 | 5 | 6 | 7 | |
| | | | | "WG | ft | "WG | ft | "WG | ft | | | | | | | | |
| 30" x 24" | 5.00 | 300 | 1417 | .015 | 23 - 37 - 69 | .021 | 18 - 29 - 54 | .027 | 10 - 17 - 31 | - | 38 | 26 | 27 | - | - | - | |
| | | 450 | 2125 | .034 | 37 - 56 - 85 | .047 | 29 - 43 - 66 | .060 | 17 - 25 - 38 | 20 | 48 | 37 | 38 | 25 | 11 | - | |
| | | 600 | 2834 | .061 | 50 - 69 - 98 | .084 | 38 - 54 - 76 | .106 | 22 - 31 - 44 | 29 | 55 | 45 | 46 | 36 | 25 | 20 | |
| | | 750 | 3542 | .095 | 62 - 77 - 109 | .131 | 48 - 60 - 85 | .166 | 28 - 35 - 49 | 36 | 60 | 51 | 52 | 44 | 36 | 31 | |
| | | 900 | 4250 | .137 | 69 - 85 - 120 | .188 | 54 - 66 - 93 | .239 | 31 - 38 - 54 | 41 | 64 | 56 | 57 | 51 | 45 | 40 | |
| 42" x 18" | 5.25 | 300 | 1482 | .015 | 24 - 38 - 71 | .021 | 18 - 29 - 55 | .027 | 11 - 17 - 32 | - | 39 | 26 | 27 | - | - | - | |
| | | 450 | 2224 | .034 | 38 - 57 - 87 | .047 | 29 - 44 - 67 | .060 | 17 - 26 - 39 | 20 | 48 | 37 | 38 | 25 | 11 | - | |
| | | 600 | 2965 | .061 | 51 - 71 - 100 | .084 | 39 - 55 - 78 | .106 | 23 - 32 - 45 | 29 | 55 | 45 | 46 | 36 | 25 | 20 | |
| | | 750 | 3706 | .095 | 63 - 79 - 112 | .131 | 49 - 61 - 87 | .166 | 28 - 36 - 50 | 36 | 60 | 51 | 52 | 44 | 36 | 31 | |
| | | 900 | 4447 | .137 | 71 - 87 - 123 | .188 | 55 - 67 - 95 | .239 | 32 - 39 - 55 | 41 | 64 | 56 | 57 | 51 | 45 | 40 | |
| 28" x 28" | 5.44 | 300 | 1547 | .015 | 24 - 39 - 72 | .021 | 19 - 30 - 56 | .027 | 11 - 17 - 33 | - | 39 | 26 | 27 | - | - | - | |
| | | 450 | 2321 | .034 | 39 - 58 - 89 | .047 | 30 - 45 - 69 | .060 | 17 - 26 - 40 | 21 | 48 | 37 | 38 | 25 | 11 | - | |
| | | 600 | 3094 | .061 | 52 - 72 - 102 | .084 | 40 - 56 - 79 | .106 | 23 - 33 - 46 | 29 | 55 | 45 | 46 | 36 | 25 | 20 | |
| | | 750 | 3868 | .095 | 65 - 81 - 114 | .131 | 50 - 63 - 89 | .166 | 29 - 36 - 51 | 36 | 60 | 51 | 52 | 45 | 37 | 31 | |
| | | 900 | 4641 | .137 | 72 - 89 - 125 | .188 | 56 - 69 - 97 | .239 | 33 - 40 - 56 | 41 | 64 | 56 | 57 | 51 | 46 | 41 | |
| 30" x 28" | 5.83 | 300 | 1661 | .015 | 25 - 40 - 75 | .021 | 19 - 31 - 58 | .027 | 11 - 18 - 34 | - | 39 | 26 | 28 | - | - | - | |
| | | 450 | 2491 | .034 | 40 - 60 - 92 | .047 | 31 - 47 - 71 | .060 | 18 - 27 - 41 | 21 | 49 | 37 | 38 | 26 | 12 | - | |
| | | 600 | 3321 | .061 | 54 - 75 - 106 | .084 | 42 - 58 - 82 | .106 | 24 - 34 - 48 | 30 | 55 | 45 | 46 | 36 | 26 | 20 | |
| | | 750 | 4151 | .095 | 67 - 84 - 118 | .131 | 52 - 65 - 92 | .166 | 30 - 38 - 53 | 36 | 61 | 51 | 52 | 45 | 37 | 32 | |
| | | 900 | 4982 | .137 | 75 - 92 - 130 | .188 | 58 - 71 - 101 | .239 | 34 - 41 - 58 | 42 | 65 | 56 | 57 | 52 | 46 | 41 | |
| 36" x 24" | 6.00 | 300 | 1707 | .015 | 25 - 41 - 76 | .021 | 20 - 32 - 59 | .027 | 11 - 18 - 34 | - | 39 | 26 | 28 | - | - | - | |
| | | 450 | 2561 | .034 | 41 - 61 - 93 | .047 | 32 - 47 - 72 | .060 | 18 - 28 - 42 | 21 | 49 | 38 | 39 | 26 | 12 | - | |
| | | 600 | 3415 | .061 | 54 - 76 - 107 | .084 | 42 - 59 - 83 | .106 | 24 - 34 - 48 | 30 | 55 | 45 | 46 | 37 | 26 | 20 | |
| | | 750 | 4269 | .095 | 68 - 85 - 120 | .131 | 53 - 66 - 93 | .166 | 31 - 38 - 54 | 36 | 61 | 52 | 52 | 45 | 37 | 32 | |
| | | 900 | 5122 | .137 | 76 - 93 - 132 | .188 | 59 - 72 - 102 | .239 | 34 - 42 - 59 | 42 | 65 | 57 | 57 | 52 | 46 | 41 | |
| 30" x 30" | 6.25 | 300 | 1782 | .015 | 26 - 42 - 78 | .021 | 20 - 32 - 60 | .027 | 12 - 19 - 35 | - | 39 | 27 | 28 | 11 | - | - | |
| | | 450 | 2674 | .034 | 42 - 63 - 95 | .047 | 32 - 48 - 74 | .060 | 19 - 28 - 43 | 21 | 49 | 38 | 39 | 26 | 12 | - | |
| | | 600 | 3565 | .061 | 56 - 78 - 110 | .084 | 43 - 60 - 85 | .106 | 25 - 35 - 49 | 30 | 56 | 46 | 47 | 37 | 26 | 21 | |
| | | 750 | 4456 | .095 | 69 - 87 - 123 | .131 | 54 - 67 - 95 | .166 | 31 - 39 - 55 | 37 | 61 | 52 | 53 | 45 | 37 | 32 | |
| | | 900 | 5347 | .137 | 78 - 95 - 134 | .188 | 60 - 74 - 104 | .239 | 35 - 43 - 60 | 42 | 65 | 57 | 58 | 52 | 46 | 41 | |
| 36" x 28" | 7.00 | 300 | 2001 | .015 | 28 - 44 - 82 | .021 | 21 - 34 - 64 | .027 | 12 - 20 - 37 | - | 40 | 27 | 28 | 11 | - | - | |
| | | 450 | 3002 | .034 | 44 - 66 - 101 | .047 | 34 - 51 - 78 | .060 | 20 - 30 - 45 | 22 | 49 | 38 | 39 | 26 | 13 | - | |
| | | 600 | 4002 | .061 | 59 - 82 - 116 | .084 | 46 - 64 - 90 | .106 | 26 - 37 - 52 | 30 | 56 | 46 | 47 | 37 | 27 | 21 | |
| | | 750 | 5003 | .095 | 74 - 92 - 130 | .131 | 57 - 71 - 101 | .166 | 33 - 41 - 59 | 37 | 61 | 52 | 53 | 46 | 38 | 32 | |
| | | 900 | 6004 | .137 | 82 - 101 - 142 | .188 | 64 - 78 - 110 | .239 | 37 - 45 - 64 | 42 | 66 | 57 | 58 | 53 | 47 | 42 | |
| 46" x 22" | 7.03 | 300 | 2003 | .015 | 28 - 44 - 82 | .021 | 21 - 34 - 64 | .027 | 12 - 20 - 37 | - | 40 | 27 | 28 | 11 | - | - | |
| | | 450 | 3005 | .034 | 44 - 66 - 101 | .047 | 34 - 51 - 78 | .060 | 20 - 30 - 45 | 22 | 49 | 38 | 39 | 26 | 13 | - | |
| | | 600 | 4007 | .061 | 59 - 82 - 116 | .084 | 46 - 64 - 90 | .106 | 27 - 37 - 52 | 30 | 56 | 46 | 47 | 37 | 27 | 21 | |
| | | 750 | 5008 | .095 | 74 - 92 - 130 | .131 | 57 - 71 - 101 | .166 | 33 - 41 - 59 | 37 | 61 | 52 | 53 | 46 | 38 | 32 | |
| | | 900 | 6010 | .137 | 82 - 101 - 143 | .188 | 64 - 78 - 110 | .239 | 37 - 45 - 64 | 42 | 66 | 57 | 58 | 53 | 47 | 42 | |
| 32" x 32" | 7.11 | 300 | 2035 | .015 | 28 - 45 - 83 | .021 | 22 - 34 - 64 | .027 | 12 - 20 - 37 | - | 40 | 27 | 28 | 11 | - | - | |
| | | 450 | 3052 | .034 | 45 - 67 - 102 | .047 | 34 - 52 - 79 | .060 | 20 - 30 - 46 | 22 | 49 | 38 | 39 | 27 | 13 | - | |
| | | 600 | 4069 | .061 | 59 - 83 - 117 | .084 | 46 - 64 - 91 | .106 | 27 - 37 - 53 | 30 | 56 | 46 | 47 | 37 | 27 | 21 | |
| | | 750 | 5086 | .095 | 74 - 93 - 131 | .131 | 57 - 72 - 102 | .166 | 33 - 42 - 59 | 37 | 61 | 52 | 53 | 46 | 38 | 33 | |
| | | 900 | 6104 | .137 | 83 - 102 - 144 | .188 | 64 - 79 - 111 | .239 | 37 - 46 - 65 | 43 | 66 | 57 | 58 | 53 | 47 | 42 | |
| 36" x 30" | 7.50 | 300 | 2148 | .015 | 29 - 46 - 85 | .021 | 22 - 35 - 66 | .027 | 13 - 21 - 38 | - | 40 | 27 | 29 | 11 | - | - | |
| | | 450 | 3222 | .034 | 46 - 69 - 104 | .047 | 35 - 53 - 81 | .060 | 21 - 31 - 47 | 22 | 50 | 38 | 40 | 27 | 13 | - | |
| | | 600 | 4296 | .061 | 61 - 85 - 121 | .084 | 47 - 66 - 93 | .106 | 27 - 38 - 54 | 31 | 56 | 46 | 47 | 38 | 27 | 21 | |
| | | 750 | 5370 | .095 | 76 - 95 - 135 | .131 | 59 - 74 - 104 | .166 | 34 - 43 - 61 | 37 | 62 | 53 | 53 | 46 | 38 | 33 | |
| | | 900 | 6444 | .137 | 85 - 104 - 148 | .188 | 66 - 81 - 114 | .239 | 38 - 47 - 66 | 43 | 66 | 58 | 58 | 53 | 47 | 42 | |
| 36" x 32" | 8.08 | 300 | 2295 | .015 | 29 - 47 - 88 | .021 | 23 - 37 - 68 | .027 | 13 - 21 - 40 | - | 41 | 28 | 29 | 12 | - | - | |
| | | 450 | 3442 | .034 | 47 - 71 - 108 | .047 | 37 - 55 - 84 | .060 | 21 - 32 - 49 | 22 | 50 | 39 | 40 | 27 | 13 | - | |
| | | 600 | 4590 | .061 | 63 - 88 - 125 | .084 | 49 - 68 - 97 | .106 | 28 - 40 - 56 | 31 | 57 | 47 | 48 | 38 | 27 | 22 | |
| | | 750 | 5737 | .095 | 79 - 98 - 139 | .131 | 61 - 76 - 108 | .166 | 35 - 44 - 63 | 38 | 62 | 53 | 54 | 46 | 38 | 33 | |
| | | 900 | 6885 | .137 | 88 - 108 - 153 | .188 | 68 - 84 - 118 | .239 | 40 - 49 - 69 | 43 | 66 | 58 | 59 | 53 | 47 | 42 | |

SUPPLY GRILLES

80, 880, 4880, 800 Series

NOTE: See notes on page I1-37.

80, 880, 4880, 800 Series | Supply

80, 880, 4880, 800 Series Performance Data: Horizontal Throw

IP DATA: 80, 580, 880, 5880, 585, 5885, 480, 4880, 800, 5800 (WITH OBD/MULTILOUVER)

| Nom Duct | Duct Area | Neck Vel | Air Flow | 0° | | 22.5° | | 45° | | NC | Octave Band, dB | | | | | |
|-----------|-----------|----------|----------|------|-----------------|-------|---------------|------|--------------|----|-----------------|----|----|----|----|----|
| | | | | Pt | Throw | Pt | Throw | Pt | Throw | | 2 | 3 | 4 | 5 | 6 | 7 |
| | | | | "WG | ft | "WG | ft | "WG | ft | | | | | | | |
| 34" x 34" | 8.03 | 300 | 2303 | .015 | 30 - 47 - 88 | .021 | 23 - 37 - 68 | .027 | 13 - 21 - 40 | - | 41 | 28 | 29 | 12 | - | - |
| | | 450 | 3455 | .034 | 47 - 71 - 108 | .047 | 37 - 55 - 84 | .060 | 21 - 32 - 49 | 22 | 50 | 39 | 40 | 27 | 13 | - |
| | | 600 | 4607 | .061 | 63 - 88 - 125 | .084 | 49 - 68 - 97 | .106 | 28 - 40 - 56 | 31 | 57 | 47 | 48 | 38 | 27 | 22 |
| | | 750 | 5758 | .095 | 79 - 99 - 140 | .131 | 61 - 76 - 108 | .166 | 36 - 44 - 63 | 38 | 62 | 53 | 54 | 46 | 38 | 33 |
| | | 900 | 6910 | .137 | 88 - 108 - 153 | .188 | 68 - 84 - 118 | .239 | 40 - 49 - 69 | 43 | 66 | 58 | 59 | 53 | 47 | 42 |
| 36" x 34" | 8.50 | 300 | 2442 | .015 | 30 - 49 - 91 | .021 | 24 - 38 - 70 | .027 | 14 - 22 - 41 | - | 41 | 28 | 29 | 12 | - | - |
| | | 425 | 3459 | .030 | 46 - 69 - 108 | .042 | 36 - 54 - 84 | .053 | 21 - 31 - 49 | 21 | 49 | 37 | 39 | 25 | 11 | - |
| | | 550 | 4477 | .051 | 60 - 87 - 123 | .070 | 46 - 67 - 95 | .089 | 27 - 39 - 55 | 29 | 55 | 45 | 46 | 35 | 23 | 18 |
| | | 675 | 5494 | .077 | 73 - 96 - 136 | .106 | 57 - 75 - 106 | .135 | 33 - 43 - 61 | 35 | 60 | 50 | 51 | 43 | 33 | 28 |
| | | 800 | 6511 | .108 | 86 - 105 - 148 | .149 | 66 - 81 - 115 | .189 | 39 - 47 - 67 | 40 | 64 | 55 | 56 | 49 | 42 | 37 |
| 42" x 30" | 8.75 | 300 | 2514 | .015 | 31 - 49 - 92 | .021 | 24 - 38 - 71 | .027 | 14 - 22 - 41 | 11 | 41 | 28 | 29 | 12 | - | - |
| | | 425 | 3561 | .030 | 47 - 70 - 110 | .042 | 36 - 54 - 85 | .053 | 21 - 32 - 49 | 21 | 49 | 38 | 39 | 25 | 11 | - |
| | | 550 | 4608 | .051 | 60 - 88 - 125 | .070 | 47 - 68 - 97 | .089 | 27 - 40 - 56 | 29 | 55 | 45 | 46 | 35 | 23 | 18 |
| | | 675 | 5656 | .077 | 74 - 98 - 138 | .106 | 58 - 76 - 107 | .135 | 33 - 44 - 62 | 35 | 60 | 50 | 51 | 43 | 34 | 28 |
| | | 800 | 6703 | .108 | 87 - 106 - 151 | .149 | 67 - 82 - 117 | .189 | 39 - 48 - 68 | 40 | 64 | 55 | 56 | 49 | 42 | 37 |
| 36" x 36" | 9.00 | 300 | 2589 | .015 | 31 - 50 - 94 | .021 | 24 - 39 - 72 | .027 | 14 - 23 - 42 | 11 | 41 | 28 | 29 | 12 | - | - |
| | | 425 | 3667 | .030 | 47 - 71 - 111 | .042 | 37 - 55 - 86 | .053 | 21 - 32 - 50 | 21 | 49 | 38 | 39 | 25 | 11 | - |
| | | 550 | 4746 | .051 | 61 - 90 - 127 | .070 | 48 - 69 - 98 | .089 | 28 - 40 - 57 | 29 | 55 | 45 | 46 | 35 | 24 | 18 |
| | | 675 | 5825 | .077 | 75 - 99 - 140 | .106 | 58 - 77 - 109 | .135 | 34 - 45 - 63 | 35 | 60 | 50 | 51 | 43 | 34 | 28 |
| | | 800 | 6903 | .108 | 88 - 108 - 153 | .149 | 68 - 84 - 118 | .189 | 40 - 49 - 69 | 40 | 64 | 55 | 56 | 49 | 42 | 37 |
| 48" x 30" | 10.00 | 300 | 2879 | .015 | 33 - 53 - 99 | .021 | 26 - 41 - 76 | .027 | 15 - 24 - 44 | 11 | 42 | 29 | 30 | 13 | - | - |
| | | 425 | 4079 | .030 | 50 - 75 - 117 | .042 | 39 - 58 - 91 | .053 | 23 - 34 - 53 | 22 | 50 | 38 | 39 | 26 | 11 | - |
| | | 550 | 5279 | .051 | 65 - 94 - 134 | .070 | 50 - 73 - 104 | .089 | 29 - 43 - 60 | 29 | 56 | 45 | 46 | 36 | 24 | 18 |
| | | 675 | 6478 | .077 | 79 - 105 - 148 | .106 | 62 - 81 - 115 | .135 | 36 - 47 - 67 | 35 | 60 | 51 | 52 | 43 | 34 | 29 |
| | | 800 | 7678 | .108 | 93 - 114 - 161 | .149 | 72 - 88 - 125 | .189 | 42 - 51 - 72 | 40 | 64 | 56 | 56 | 50 | 43 | 37 |
| 38" x 38" | 10.03 | 300 | 2891 | .015 | 33 - 53 - 99 | .021 | 26 - 41 - 77 | .027 | 15 - 24 - 44 | 11 | 42 | 29 | 30 | 13 | - | - |
| | | 425 | 4095 | .030 | 50 - 75 - 118 | .042 | 39 - 58 - 91 | .053 | 23 - 34 - 53 | 22 | 50 | 38 | 39 | 26 | 11 | - |
| | | 550 | 5300 | .051 | 65 - 95 - 134 | .070 | 50 - 73 - 104 | .089 | 29 - 43 - 60 | 29 | 56 | 45 | 46 | 36 | 24 | 18 |
| | | 675 | 6504 | .077 | 80 - 105 - 148 | .106 | 62 - 81 - 115 | .135 | 36 - 47 - 67 | 35 | 60 | 51 | 52 | 43 | 34 | 29 |
| | | 800 | 7709 | .108 | 93 - 114 - 161 | .149 | 72 - 88 - 125 | .189 | 42 - 51 - 73 | 40 | 64 | 56 | 56 | 50 | 43 | 37 |
| 42" x 36" | 10.50 | 300 | 3029 | .015 | 34 - 54 - 101 | .021 | 26 - 42 - 78 | .027 | 15 - 24 - 46 | 11 | 42 | 29 | 30 | 13 | - | - |
| | | 425 | 4292 | .030 | 51 - 77 - 120 | .042 | 40 - 60 - 93 | .053 | 23 - 35 - 54 | 22 | 50 | 38 | 40 | 26 | 12 | - |
| | | 550 | 5554 | .051 | 66 - 97 - 137 | .070 | 51 - 75 - 106 | .089 | 30 - 44 - 62 | 29 | 56 | 46 | 47 | 36 | 24 | 19 |
| | | 675 | 6816 | .077 | 81 - 107 - 152 | .106 | 63 - 83 - 118 | .135 | 37 - 48 - 68 | 36 | 61 | 51 | 52 | 44 | 34 | 29 |
| | | 800 | 8078 | .108 | 95 - 117 - 165 | .149 | 74 - 91 - 128 | .189 | 43 - 53 - 74 | 41 | 65 | 56 | 57 | 50 | 43 | 38 |
| 46" x 34" | 10.86 | 300 | 3135 | .015 | 34 - 55 - 103 | .021 | 27 - 43 - 80 | .027 | 16 - 25 - 46 | 11 | 42 | 29 | 30 | 13 | - | - |
| | | 425 | 4441 | .030 | 52 - 78 - 123 | .042 | 40 - 61 - 95 | .053 | 23 - 35 - 55 | 22 | 50 | 39 | 40 | 26 | 12 | - |
| | | 550 | 5747 | .051 | 68 - 99 - 139 | .070 | 52 - 76 - 108 | .089 | 30 - 44 - 63 | 30 | 56 | 46 | 47 | 36 | 24 | 19 |
| | | 675 | 7053 | .077 | 83 - 109 - 154 | .106 | 64 - 85 - 120 | .135 | 37 - 49 - 69 | 36 | 61 | 51 | 52 | 44 | 35 | 29 |
| | | 800 | 8359 | .108 | 97 - 119 - 168 | .149 | 75 - 92 - 130 | .189 | 44 - 53 - 76 | 41 | 65 | 56 | 57 | 50 | 43 | 38 |
| 42" x 38" | 11.06 | 300 | 3201 | .015 | 35 - 56 - 104 | .021 | 27 - 43 - 81 | .027 | 16 - 25 - 47 | 12 | 42 | 29 | 30 | 13 | - | - |
| | | 425 | 4535 | .030 | 53 - 79 - 124 | .042 | 41 - 61 - 96 | .053 | 24 - 36 - 56 | 22 | 50 | 39 | 40 | 26 | 12 | - |
| | | 550 | 5869 | .051 | 68 - 100 - 141 | .070 | 53 - 77 - 109 | .089 | 31 - 45 - 63 | 30 | 56 | 46 | 47 | 36 | 25 | 19 |
| | | 675 | 7203 | .077 | 84 - 110 - 156 | .106 | 65 - 86 - 121 | .135 | 38 - 50 - 70 | 36 | 61 | 51 | 52 | 44 | 35 | 29 |
| | | 800 | 8536 | .108 | 98 - 120 - 170 | .149 | 76 - 93 - 132 | .189 | 44 - 54 - 76 | 41 | 65 | 56 | 57 | 50 | 43 | 38 |
| 40" x 40" | 11.11 | 300 | 3210 | .015 | 35 - 56 - 104 | .021 | 27 - 43 - 81 | .027 | 16 - 25 - 47 | 12 | 42 | 29 | 30 | 13 | - | - |
| | | 425 | 4547 | .030 | 53 - 79 - 124 | .042 | 41 - 61 - 96 | .053 | 24 - 36 - 56 | 22 | 50 | 39 | 40 | 26 | 12 | - |
| | | 550 | 5884 | .051 | 68 - 100 - 141 | .070 | 53 - 77 - 109 | .089 | 31 - 45 - 63 | 30 | 56 | 46 | 47 | 36 | 25 | 19 |
| | | 675 | 7221 | .077 | 84 - 110 - 156 | .106 | 65 - 86 - 121 | .135 | 38 - 50 - 70 | 36 | 61 | 51 | 52 | 44 | 35 | 29 |
| | | 800 | 8559 | .108 | 98 - 120 - 170 | .149 | 76 - 93 - 132 | .189 | 44 - 54 - 77 | 41 | 65 | 56 | 57 | 50 | 43 | 38 |
| 48" x 36" | 12.00 | 300 | 3470 | .015 | 36 - 58 - 108 | .021 | 28 - 45 - 84 | .027 | 16 - 26 - 49 | 12 | 42 | 29 | 31 | 14 | - | - |
| | | 425 | 4916 | .030 | 55 - 82 - 129 | .042 | 43 - 64 - 100 | .053 | 25 - 37 - 58 | 22 | 50 | 39 | 40 | 27 | 12 | - |
| | | 550 | 6362 | .051 | 71 - 104 - 147 | .070 | 55 - 80 - 114 | .089 | 32 - 47 - 66 | 30 | 56 | 46 | 47 | 36 | 25 | 19 |
| | | 675 | 7807 | .077 | 87 - 115 - 162 | .106 | 68 - 89 - 126 | .135 | 39 - 52 - 73 | 36 | 61 | 52 | 53 | 44 | 35 | 29 |
| | | 800 | 9253 | .108 | 102 - 125 - 177 | .149 | 79 - 97 - 137 | .189 | 46 - 56 - 80 | 41 | 65 | 56 | 57 | 51 | 43 | 38 |

NOTE: See notes on page I1-37.

80, 880, 4880, 800 Series Performance Data: Horizontal Throw
IP DATA: 80, 580, 880, 5880, 585, 5885, 480, 4880, 800, 5800 (WITH OBD/MULTILOUVER)

| Nom Duct | Duct Area | Neck Vel | Air Flow | 0° | | | 22.5° | | | 45° | | | NC | Octave Band, dB | | | | | | |
|-----------|-----------|----------|----------|------|-----------------|--|-------|----------------|--|------|--------------|--|----|-----------------|----|----|----|----|----|--|
| | | | | Pt | Throw | | Pt | Throw | | Pt | Throw | | | 2 | 3 | 4 | 5 | 6 | 7 | |
| | | | | "WG | ft | | "WG | ft | | "WG | ft | | | | | | | | | |
| In | ft² | FPM | CFM | "WG | ft | | "WG | ft | | "WG | ft | | | | | | | | | |
| 42" x 42" | 12.25 | 300 | 3545 | .015 | 37 - 59 - 109 | | .021 | 28 - 46 - 85 | | .027 | 16 - 26 - 49 | | 12 | 42 | 30 | 31 | 14 | - | - | |
| | | 425 | 5022 | .030 | 55 - 83 - 130 | | .042 | 43 - 65 - 101 | | .053 | 25 - 37 - 59 | | 22 | 51 | 39 | 40 | 27 | 12 | - | |
| | | 550 | 6499 | .051 | 72 - 105 - 148 | | .070 | 56 - 81 - 115 | | .089 | 32 - 47 - 67 | | 30 | 57 | 46 | 47 | 37 | 25 | 19 | |
| | | 675 | 7976 | .077 | 88 - 116 - 164 | | .106 | 68 - 90 - 127 | | .135 | 40 - 52 - 74 | | 36 | 61 | 52 | 53 | 44 | 35 | 30 | |
| | | 800 | 9453 | .108 | 103 - 126 - 179 | | .149 | 80 - 98 - 139 | | .189 | 46 - 57 - 80 | | 41 | 65 | 56 | 57 | 51 | 43 | 38 | |
| 44" x 44" | 13.44 | 300 | 3897 | .015 | 38 - 62 - 115 | | .021 | 30 - 48 - 89 | | .027 | 17 - 28 - 52 | | 12 | 43 | 30 | 31 | 14 | - | - | |
| | | 425 | 5521 | .030 | 58 - 87 - 137 | | .042 | 45 - 68 - 106 | | .053 | 26 - 39 - 61 | | 23 | 51 | 40 | 41 | 27 | 13 | - | |
| | | 550 | 7145 | .051 | 75 - 110 - 155 | | .070 | 58 - 85 - 120 | | .089 | 34 - 49 - 70 | | 31 | 57 | 47 | 48 | 37 | 25 | 20 | |
| | | 675 | 8768 | .077 | 92 - 122 - 172 | | .106 | 72 - 94 - 133 | | .135 | 42 - 55 - 77 | | 37 | 62 | 52 | 53 | 45 | 35 | 30 | |
| | | 800 | 10392 | .108 | 108 - 133 - 187 | | .149 | 84 - 103 - 145 | | .189 | 49 - 60 - 84 | | 42 | 66 | 57 | 58 | 51 | 44 | 39 | |
| 48" x 42" | 14.00 | 300 | 4061 | .015 | 39 - 63 - 117 | | .021 | 30 - 49 - 91 | | .027 | 18 - 28 - 53 | | 13 | 43 | 30 | 31 | 14 | - | - | |
| | | 425 | 5752 | .030 | 59 - 89 - 139 | | .042 | 46 - 69 - 108 | | .053 | 27 - 40 - 63 | | 23 | 51 | 40 | 41 | 27 | 13 | - | |
| | | 550 | 7444 | .051 | 77 - 112 - 159 | | .070 | 60 - 87 - 123 | | .089 | 35 - 50 - 71 | | 31 | 57 | 47 | 48 | 37 | 26 | 20 | |
| | | 675 | 9136 | .077 | 94 - 124 - 176 | | .106 | 73 - 96 - 136 | | .135 | 42 - 56 - 79 | | 37 | 62 | 52 | 53 | 45 | 36 | 30 | |
| | | 800 | 10828 | .108 | 110 - 135 - 191 | | .149 | 86 - 105 - 148 | | .189 | 50 - 61 - 86 | | 42 | 66 | 57 | 58 | 51 | 44 | 39 | |
| 46" x 46" | 14.69 | 300 | 4266 | .015 | 40 - 64 - 120 | | .021 | 31 - 50 - 93 | | .027 | 18 - 29 - 54 | | 13 | 43 | 30 | 32 | 14 | - | - | |
| | | 425 | 6043 | .030 | 61 - 91 - 143 | | .042 | 47 - 71 - 111 | | .053 | 27 - 41 - 64 | | 23 | 51 | 40 | 41 | 28 | 13 | - | |
| | | 550 | 7821 | .051 | 79 - 115 - 163 | | .070 | 61 - 89 - 126 | | .089 | 35 - 52 - 73 | | 31 | 57 | 47 | 48 | 37 | 26 | 20 | |
| | | 675 | 9598 | .077 | 97 - 127 - 180 | | .106 | 75 - 99 - 140 | | .135 | 44 - 57 - 81 | | 37 | 62 | 53 | 54 | 45 | 36 | 30 | |
| | | 800 | 11375 | .108 | 113 - 139 - 196 | | .149 | 88 - 107 - 152 | | .189 | 51 - 62 - 88 | | 42 | 66 | 57 | 58 | 51 | 44 | 39 | |
| 48" x 46" | 15.33 | 300 | 4454 | .015 | 41 - 66 - 123 | | .021 | 32 - 51 - 95 | | .027 | 18 - 30 - 55 | | 13 | 43 | 31 | 32 | 15 | - | - | |
| | | 425 | 6310 | .030 | 62 - 93 - 146 | | .042 | 48 - 72 - 113 | | .053 | 28 - 42 - 66 | | 23 | 52 | 40 | 41 | 28 | 13 | - | |
| | | 550 | 8166 | .051 | 81 - 117 - 166 | | .070 | 62 - 91 - 129 | | .089 | 36 - 53 - 75 | | 31 | 58 | 47 | 48 | 37 | 26 | 20 | |
| | | 675 | 10022 | .077 | 99 - 130 - 184 | | .106 | 77 - 101 - 143 | | .135 | 44 - 59 - 83 | | 37 | 62 | 53 | 54 | 45 | 36 | 31 | |
| | | 800 | 11878 | .108 | 116 - 142 - 200 | | .149 | 90 - 110 - 155 | | .189 | 52 - 64 - 90 | | 42 | 66 | 57 | 58 | 52 | 44 | 39 | |
| 48" x 48" | 16.00 | 300 | 4651 | .015 | 42 - 67 - 125 | | .021 | 33 - 52 - 97 | | .027 | 19 - 30 - 56 | | 13 | 44 | 31 | 32 | 15 | - | - | |
| | | 425 | 6589 | .030 | 64 - 95 - 149 | | .042 | 49 - 74 - 116 | | .053 | 29 - 43 - 67 | | 24 | 52 | 40 | 41 | 28 | 13 | - | |
| | | 550 | 8527 | .051 | 82 - 120 - 170 | | .070 | 64 - 93 - 132 | | .089 | 37 - 54 - 76 | | 31 | 58 | 47 | 48 | 38 | 26 | 20 | |
| | | 675 | 10465 | .077 | 101 - 133 - 188 | | .106 | 78 - 103 - 146 | | .135 | 45 - 60 - 85 | | 37 | 63 | 53 | 54 | 45 | 36 | 31 | |
| | | 800 | 12403 | .108 | 118 - 145 - 205 | | .149 | 92 - 112 - 159 | | .189 | 53 - 65 - 92 | | 42 | 66 | 58 | 58 | 52 | 45 | 39 | |

SUPPLY GRILLES

NOTES: Throw values are given for terminal velocities of 150, 100, and 50 FPM. Throw values are given for isothermal conditions. NC values are based on octave band 2 - 7 sound power levels minus a room absorption of 10dB, re 10⁻¹² Watts. Dash in space denotes a NC or dB value of less than 10. Data was obtained from tests conducted in accordance with ANSI/ASHRAE Standard 70, ISO Standard 5219, and ISO Standard 3741. See correction factors in table below. See Krueger's selection software for performance data not shown, including octave band data.

| NC Correction Damper (Add) | | NC Correction Blade Deflection (Add) | | | Throw Correction (Multiply) | | Pt Correction (Multiply) | |
|----------------------------|--------|--------------------------------------|-------|-----|-----------------------------|--------|--------------------------|--------|
| OBD | No OBD | 0° | 22.5° | 45° | OBD | No OBD | OBD | No OBD |
| 0 | -2 | 0 | +4 | +9 | 1 | 0.98 | 1 | 0.88 |

8000000000



January 20, 2017

Oxnard School District
 1051 South A Street
 Oxnard, CA, 93030

Attn: Ms. Marlene Hickle, CFW Inc.

Subject: Swinerton Builders Job 16055106 - Lemonwood K-8 School LLB
 PCI No. 0055.1
 TEC Change Order Request # 005r3

*2/7/14 -
 corrected -
 credit for
 trenching +
 combined trench
 #12, 124 yo
 savings from
 11/15/14*

Dear ,

We request a Change Order to our contract for the following:

Change electrical duct bank requirements per EEOR direction from MSB7 to MSB9 in areas described in RFI24r1. Change conduit routing per SCE "B"

| Phase | Category | Description | Subcontractor | Quote |
|--------|----------|---|------------------------|------------------|
| 260010 | 71140 | Change electrical duct bank requirements per EEOR direction from MSB7 to MSB9 in areas described in RFI24r1. Change conduit routing per SCE "B" | TAFT ELECTRIC COMPANY | 27,265.00 |
| | | | Subtotal | 27,265.00 |
| 007480 | 71160 | Subguard | 1.15% | 313.55 |
| 007410 | 71160 | Builders Risk | 0.6% | 165.47 |
| 007420 | 71160 | General Insurance | 1.15% | 317.15 |
| 007510 | 71160 | P&P Bond | 1% | 272.65 |
| 991000 | 79999 | Change Order Fee | 15% | 4,209.18 |
| | | | Markup Subtotal | 5,278.00 |
| | | | PCI Total | 32,543.00 |

TOTAL AMOUNT OF THIS CHANGE ORDER REQUEST: **32,543.00.**

Please NOTE:

- » The incorporation of this revision in to the contractual scope of work may have an impact on our schedule and cost, which is yet to be finalized. Once determined, the job schedule and cost will be adjusted accordingly to show the effect of this revision on the final project completion date.
- » The terms (cost and schedule impact) of this change order request are subject to review and a requote if not accepted within 10 days of its issuance.
- » This request does not include additional cost or delay due to late approval.

We **HAVE NOT** proceeded with this revised work per your instructions. Please issue a change order.

2/7/17 - M.H. TB 2/7/17



Upon acceptance of this change order request, a formal change order will be issued. Acceptance also acknowledges that Swinerton Builders is directed to proceed with the above change in scope.

If you have any questions or comments pertaining to this matter, please contact the undersigned.

Sincerely,
Swinerton Builders

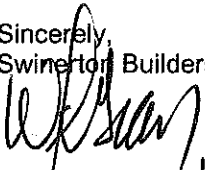

Bill Gray
PM
Date: _____

1/20/2017

Quotation accepted by:
Oxnard School District

By: _____

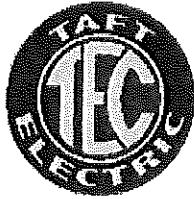
Date: _____



Taft Electric Company

1694 Eastman Avenue
Ventura, CA 93003
(805)642-0121
Contractor License # 772245

Change Order Request

Detailed, Grouped by Each Number

2241 Lemonwood
2200 Carnegie Court
Oxnard, CA 93033

Project # 2241
Tel: Fax:

TAFT ELECTRIC COMPANY

Change Order Request: 005 R003

Date: 12/5/2016

To: Bill Gray
Swinerton Builders
865 S. Figueroa Street
Los Angeles, CA 90017

From: Matt Gobuly
TAFT ELECTRIC COMPANY
P.O. Box 3416
Ventura, CA 93006

| Description | Category | Status |
|---------------|----------|-----------|
| MSB-9 Conduit | | Submitted |

| Reference | Required By | Days Req | Amt Req |
|---------------|-------------|----------|---------|
| TEC RFI 003R1 | 12/12/2016 | 0 | 27,265 |

Notes

We are submitting the above cost for the additional work related to TEC RFI 003R1 MSB-9 conduits and credit for an omitted 5" SCE conduit. This COR includes:

- Credit for (1)3/4" conduit 650'
- Credit 800' 5" Edison conduit
- Add (2)5" conduits 650', additional conduit support,excavation and encasement.

Reroute Edison conduit: Sheet E1.1.0 shows SCE conduit exiting the East. SCE B Drawing re-routes the conduit South.
-R&R Power pole, shake plates, gravel & sidewalk to accomodate new routing.

Schedule impact: 3-4 days for additional excavation, installation of conduit and encasement.

This quote is valid for 30 calendar days from the above date. we reserve our right to re-quote this proposal should the approval take longer than 30 days.

Attached is the back up for your review. Please call should you have any questions.

Matt Gobuly
Project Manager

| PCO No | Date | Reference | Amt Prop | Days Req | Category | Reason |
|--------------------|------|--------------|----------|----------|----------|--------|
| Description | | Notes | | | | |

Approved By:

Signature _____

Name _____ **Date** _____

Job ID: 2241 LEMONWOOD COR
 Project: 2241 Lemonwood COR



Takeoff

Vendor: COST

Labor Level: LABOR 1

6 Dec 2016 8:09:53

Region: COR 005 R3

| Item # | Qty | U/M | Q/M | Size | Description | Material Unit | Material Result | Labor Unit | Labor Result |
|----------------------|-------|-----|-----|----------------|--------------------------------------|------------------|-----------------|--------------|--------------|
| | 0 | | | | CREDIT (1)3/4" -650' | | | | |
| 10074 | -650 | FT | M | 3/4 | PVC SCH 40 10' LAID IN TRENCH LBR. | 0.2821 | -183.37 | 0.0350 | -22.75 |
| 20001 | -2 | EA | M | 3/4 | PVC SCH 40 90-DEG ELBOW | 0.5848 | -1.17 | 0.2200 | -0.44 |
| 30311 | -4 | EA | M | 3/4 | PVC END BELLS | 0.0000 | 0.00 | 0.1400 | -0.56 |
| 30338 | -1 | EA | M | 3/4 | PVC CONDUIT CAP | 1.0934 | -1.09 | 0.1200 | -0.12 |
| 10 | -65 | | M | 3/4 | POLYMER SUPPORT - PUNCHOUT | 0.0000 | 0.00 | 0.0400 | -2.60 |
| 40032 | -2 | EA | M | QUART | PVC (GLUE) CEMENT | 9.6462 | -19.29 | 0.2000 | -0.40 |
| 500125 | -670 | FT | M | | PULL ROPE 1/4" | 0.0708 | -47.46 | 0.0039 | -2.61 |
| | 0 | | | | CREDIT (1) 5" SCE CONDUIT -800' | | | | |
| 10083 | -800 | FT | M | 5 | PVC SCH 40 10' LAID IN TRENCH LBR. | 4.0104 | -3,208.30 | 0.0575 | -46.00 |
| | 0 | | | | ADD (2)5" -650' | | | | |
| 15 | 6 | | M | | PVC SCH 40 90-DEG ELBOW 12'R | 131.2349 | 787.41 | 1.5500 | 9.30 |
| 30320 | 8 | EA | M | 5 | PVC END BELLS | 7.1633 | 57.31 | 0.4500 | 3.60 |
| 40032 | 12 | EA | M | QUART | PVC (GLUE) CEMENT | 9.6462 | 115.75 | 0.2000 | 2.40 |
| 30353 | 2 | EA | M | 5 | PVC CONDUIT PLUG | 2.5772 | 5.15 | 0.3500 | 0.70 |
| 500125 | 1,340 | FT | M | | PULL ROPE 1/4" | 0.0708 | 94.93 | 0.0039 | 5.23 |
| 12 | 130 | | M | 5 | POLYMER SUPPORT - PUNCHOUT | 0.0000 | 0.00 | 0.0700 | 9.10 |
| 13 | 130 | | M | | POLYMER SUPPORT - MATERIAL PER SQ/FT | 2.2500 | 292.50 | 0.0000 | 0.00 |
| 19 | 4 | | M | | REMOVE & REPLACE SC GRAVEL | 0.0000 | 0.00 | 1.0000 | 4.00 |
| 390123 | 410 | FT | M | 12" X 36" DEEP | BACKHOE TRENCH+BACKFILL | 3.5000 | 1,435.00 | 0.0200 | 8.20 |
| 16 | 240 | | M | 12" X 72" DEEP | BACKHOE TRENCH+BACKFILL | 7.5000 | 1,800.00 | 0.0200 | 4.80 |
| 390083 | 15 | FT | M | 12" WIDE | HAND TRIM SAND TRENCH | 0.0000 | 0.00 | 0.4500 | 6.75 |
| 10083 | 1,300 | FT | M | 5 | PVC SCH 40 10' LAID IN TRENCH LBR. | 4.0104 | 5,213.48 | 0.0575 | 74.75 |
| 390429 | 44 | YD | M | 2 SACK SLURRY | CONCRETE ENCASUREMENT | 103.5000 | 4,554.00 | 0.3000 | 13.20 |
| Phase Totals: | | | | | | 10,894.85 | | 66.54 | |
| Job Totals: | | | | | | 10,894.85 | | 66.54 | |

Taft Electric Company

1694 Eastman Avenue
 Ventura, CA 93003

Phone: 805-642-0121
 Web: www.taftelectric.com



Taft Electric Company

1694 Eastman Avenue
Ventura, CA 93003
(805)642-0121
Contractor License # 772245

TEC RFI 003 R001

Detailed, RFIs without Routing Information Grouped by RFI Number

2241 Lemonwood Project # 2241 TAFT ELECTRIC COMPANY
Tel: Fax:

RFI #: 003 R001 Date Created: 6/30/2016

| RFI Issued To: | Contact Name | Author Company | Authorized By |
|---|----------------|---|---------------|
| Swinerton Builders 865 S. Figueroa Street Los Angeles, CA 90017 | Nalani Scanlon | TAFT ELECTRIC COMPANY P.O. Box 3416 Ventura, CA 93006 | Matt Gobuty |

RFI Answered By: Owner RFI Number

| Subject | Discipline | Category |
|-----------------------|------------|----------|
| MSB-9 Future Conduits | Electrical | |

| Cost Impact | Amount | Sched Impact | Days | Dwg Impact |
|-------------|--------|--------------|------|------------|
| Not Sure | | Not Sure | | Not Sure |

| Cost Impact Comments | Sched Impact Comments | Dwg Impact Comments |
|----------------------|-----------------------|---------------------|
| | | |

| Cc: Company Name | Contact Name | Copies | Notes |
|------------------|--------------|--------|-------|
| | | | |

Question Date Required:

On E5.1 Single Line Distribution Diagram, MSB-9 shows (2) 5" conduits for future use. On E1.1.0 at the Northwest corner of Classroom Building 1, there is a terminated conduit marked MSB-7, indicating that it is a 3/4" for future irrigation. We believe this is incorrect and should be marked MSB-9 indicating the (2)5" for future power. Please confirm (see attached sketch).

Suggestion

Answer Date Answered:

From: Nalani Scanlon <NScanlon@swinerton.com>
Sent: Thursday, July 14, 2016 9:33 AM
To: Matt Gobuty
Cc: Bill Gray
Subject: RE: 2241 Lemonwood TEC RFI 003R1 MSB-9 conduits - CRITICAL

Importance: High

Matt,

Due to the Architect being out of the office for a week, the RFI will not be officially answered in the system until his return. However, due to the critical nature of procurement, please proceed with the answer noted by the EEOR.

Thanks,

Nalani Scanlon

Senior PE | SWINERTON BUILDERS

865 S. Figueroa Street, Suite 3000 | Los Angeles, CA 90017

T 213.896.3480 | C 213.334.1807 | www.swinerton.com

JOBSITE OFFICE: 2200 Carnegie Ct., Oxnard, CA 93033

nscanlon@swinerton.com

123

INTEGRITY | LEADERSHIP | PASSION | EXCELLENCE

From: Matt Gobuty [mailto:mgobuty@taftelectric.com]
Sent: Thursday, July 14, 2016 9:08 AM
To: Nalani Scanlon
Cc: Bill Gray; Scott Augustine
Subject: 2241 Lemonwood TEC RFI 003R1 MSB-9 conduits - CRITICAL

Good morning,

I noticed that this RFI is potentially answered, but I haven't seen a response and the status remains OPEN. **This RFI answer is CRITICAL to our installation.** To meet the schedule we must release underground pullboxes & custom fabbed conduit supports for this ductbank no later than tomorrow.

If possible, please expedite this RFI and provide us with an official answer no later than tomorrow, Friday 7/15

Thank you

RFI No. 00024R1
 From Nalani Scanlon
 Co-Author Matt Gobuty
 Forwarded From TAFT-00009
 To Tom Bardwell
 CC Bill Voller, Paul Vernier
 Subject TEC RFI 003 R1
 Date Created 2016-07-11
 RFI Type Electrical
 Schedule / Activity ID
 Spec Section
 Other RFI Type

Source
 Question **On E5.1 Single Line Distribution Diagram, MSB-9 shows (2) 5" conduits for future use. On E: incorrect and should be marked MSB-9 indicating the (2)5" for future power. Please confirm**
 Suggestion **Confirm that conduit marked MSR-7 should be MSB-9 (@NW corner of BLDG 1)**
 Possible Cost Impact Potentially
 Possible Time Impact Potentially
 Answered By
 Date Answered
 Answer

Sort

| | |
|--|----------------------------------|
| Author: Andrea Lawson Confirmed, MSB-7 should be MSB-9 at the NW corner of Bldg 1. | Date: 07/13/2016 09:06 AM |
|--|----------------------------------|

| | |
|---|----------------------------------|
| Author: Nalani Scanlon Forwarded by Nalani Scanlon to Tom Bardwell as 00024R1 | Date: 07/11/2016 11:02 AM |
|---|----------------------------------|

Matt Gobuty
 Project Manager
 Taft Electric
 (805) 654-7994
mgobuty@taftelectric.com



October 10, 2016

Oxnard School District
1051 South A Street
Oxnard, CA, 93030

Attn: Mr. Yuri Calderon/CFW, INC.

Subject: Swinerton Builders Job 16055106 - Lemonwood K-8 School LLB
PCI No. 0055 Electrical duct bank changes per RFI 24r1

Dear Mr. Calderon,

We request a Change Order to our contract for the following:

Change electrical duct bank requirements per EEOR direction from MSB7 to MSB9 in areas described in RFI24r1. Change conduit routing per SCE "B" drawing

| Phase | Category | Description | Subcontractor | Quote |
|--------|----------|-------------------|------------------------|------------------|
| 260010 | 71140 | Electrical | TAFT ELECTRIC COMPANY | 37,423.00 |
| | | | Subtotal | 37,423.00 |
| 007480 | 71160 | Subguard | 1.15% | 430.37 |
| 007410 | 71160 | Builders Risk | 0.6% | 227.12 |
| 007420 | 71160 | General Insurance | 1.15% | 435.31 |
| 007480 | 71160 | P&P Bond | 1% | 374.23 |
| 991000 | 79999 | Fee | 15% | 5,777.37 |
| | | | Markup Subtotal | 7,244.40 |
| | | | PCI Total | 44,667.40 |

TOTAL AMOUNT OF THIS CHANGE ORDER REQUEST: **44,667.40.**

Please NOTE:

- » The incorporation of this revision in to the contractual scope of work may have an impact on our schedule, which is yet to be finalized. Once determined, the job schedule will be adjusted accordingly to show the effect of this revision on the final project completion date..
- » The terms (cost and schedule impact) of this change order request are subject to review and a requote if not accepted within days of its issuance.
- » This request does not include additional cost or delay due to late approval.

We **HAVE** proceeded with this revised work per your instructions. Please issue a change order.



Upon acceptance of this change order request, a formal change order will be issued. Acceptance also acknowledges that Swinerton Builders has proceeded with the above change in scope.

If you have any questions or comments pertaining to this matter, please contact the undersigned.

Sincerely,
Swinerton Builders

Bill Gray
PM
Date: _____

10/11/2016

Quotation accepted by:
Oxnard School District

By: _____

Date: _____

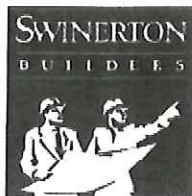

October 10, 2016

Oxnard School District
 1051 South A Street
 Oxnard, CA, 93030

Attn: Mr. Yuri Calderon/CFW, INC.

Subject: Swinerton Builders Job 16055106 - Lemonwood K-8 School LLB
 PCI No. 0055 Electrical duct bank changes per RFI 24r1

*11/15/14 Review / correct
 contingency
 credit coming
 for trenching
 + Combined trench
 Electrical Engineer of Record*

Dear Mr. Calderon,

We request a Change Order to our contract for the following:

Change electrical duct bank requirements per EEOR direction from MSB7 to MSB9 in areas described in RFI24r1. Change conduit routing per SCE "B" drawing

| Phase | Category | Description | Subcontractor | Quote |
|--------|----------|-------------------|------------------------|------------------|
| 260010 | 71140 | Electrical | TAFT ELECTRIC COMPANY | 37,423.00 |
| | | | Subtotal | 37,423.00 |
| 007480 | 71160 | Subguard | 1.15% | 430.37 |
| 007410 | 71160 | Builders Risk | 0.6% | 227.12 |
| 007420 | 71160 | General Insurance | 1.15% | 435.31 |
| 007480 | 71160 | P&P Bond | 1% | 374.23 |
| 991000 | 79999 | Fee | 15% | 5,777.37 |
| | | | Markup Subtotal | 7,244.40 |
| | | | PCI Total | 44,667.40 |

Question Markup

TOTAL AMOUNT OF THIS CHANGE ORDER REQUEST: **44,667.40.**

Please NOTE:

- » The incorporation of this revision in to the contractual scope of work may have an impact on our schedule, which is yet to be finalized. Once determined, the job schedule will be adjusted accordingly to show the effect of this revision on the final project completion date..
- » The terms (cost and schedule impact) of this change order request are subject to review and a requote if not accepted within days of its issuance.
- » This request does not include additional cost or delay due to late approval.

X We **HAVE** proceeded with this revised work per your instructions. Please issue a change order.



Upon acceptance of this change order request, a formal change order will be issued. Acceptance also acknowledges that Swinerton Builders has proceeded with the above change in scope.

If you have any questions or comments pertaining to this matter, please contact the undersigned.

Sincerely,
Swinerton Builders

Bill Gray
PM

Date: 10/11/2016

Quotation accepted by:
Oxnard School District

By: _____

Date: _____



October 10, 2016

Oxnard School District
1051 South A Street
Oxnard, CA, 93030

Attn: Ms. Lisa Cline

Subject: Swinerton Builders Job 16055106 - Lemonwood K-8 School LLB
PCI No. 0055 Electrical duct bank changes per RFI 24r1

Dear Ms. Cline ,

We request a Change Order to our contract for the following:

Change electrical duct bank requirements per EEOR direction from MSB7 to MSB9 in areas described in RFI24r1. Change conduit routing per SCE "B" drawing

| Phase | Category | Description | Subcontractor | Quote |
|--------|----------|-------------------|------------------------|------------------|
| 260010 | 71140 | Electrical | TAFT ELECTRIC COMPANY | 37,423.00 |
| | | | Subtotal | 37,423.00 |
| 007480 | 71160 | Subguard | 1.15% | 430.37 |
| 007410 | 71160 | Builders Risk | 0.6% | 227.12 |
| 007420 | 71160 | General Insurance | 1.15% | 435.31 |
| 007480 | 71160 | P&P Bond | 1% | 374.23 |
| 991000 | 79999 | Fee | 15% | 5,777.37 |
| | | | Markup Subtotal | 7,244.40 |
| | | | PCI Total | 44,667.40 |

TOTAL AMOUNT OF THIS CHANGE ORDER REQUEST: **44,667.40.**

Please NOTE:

- » The incorporation of this revision in to the contractual scope of work may have an impact on our schedule, which is yet to be finalized. Once determined, the job schedule will be adjusted accordingly to show the effect of this revision on the final project completion date..
- » The terms (cost and schedule impact) of this change order request are subject to review and a requote if not accepted within days of its issuance.
- » This request does not include additional cost or delay due to late approval.

X We **HAVE** proceeded with this revised work per your instructions. Please issue a change order.



Upon acceptance of this change order request, a formal change order will be issued. Acceptance also acknowledges that Swinerton Builders has proceeded with the above change in scope.

If you have any questions or comments pertaining to this matter, please contact the undersigned.

Sincerely,
Swinerton Builders

Bill Gray
PM
Date: _____

10/10/2016

Quotation accepted by:
Oxnard School District

By: _____

Date: _____

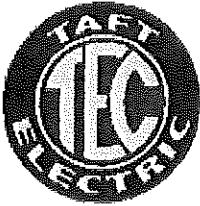

Taft Electric Company

1694 Eastman Avenue
Ventura, CA 93003

(805)642-0121
Contractor License # 772245

Change Order Request

Detailed, Grouped by Each Number

2241 Lemonwood
2200 Carnegie Court
Oxnard, CA 93033

Project # 2241
Tel: Fax:

TAFT ELECTRIC COMPANY

Change Order Request: 005 R001

Date: 7/19/2016

To: Bill Gray
Swinerton Builders
865 S. Figueroa Street
Los Angeles, CA 90017

From: Matt Gobuty
TAFT ELECTRIC COMPANY
P.O. Box 3416
Ventura, CA 93006

| Description | Category | Status |
|---------------|----------|-----------|
| MSB-9 Conduit | | Submitted |

| Reference | Required By | Days Req | Amt Req |
|---------------|-------------|----------|---------|
| TEC RFI 003R1 | 7/26/2016 | 0 | 37,423 |

Notes

We are submitting the above cost for the additional work related to TEC RFI 003R1 MSB-9 conduits. The drawings show (1)3/4" conduit MSB-7 terminating to the NW corner of Bldg 1. This should be marked MSB-9, (2)5" conduits for future use. This COR includes:

- Credit for (1)3/4" conduit 650'
- Add (2)5" conduits 650', additional conduit support,excavation and encasement.

Reroute Edison conduit: Sheet E1.1.0 shows SCE conduit exiting the East. SCE B Drawing re-routs the conduit South.
-R&R Power pole, shake plates, gravel & sidewalk to accomodate new routing.

Schedule impact: 3-4 days for additional excavation, installation of conduit and encasement.

This quote is valid for 30 calendar days from the above date. we reserve our right to re-quote this proposal should the approval take longer than 30 days.

Attached is the back up for your review. Please call should you have any questions.

Matt Gobuty
Project Manager

| PCO No | Date | Reference | Amt Prop | Days Req | Category | Reason |
|--------------------|------|-----------|--------------|----------|----------|--------|
| Description | | | Notes | | | |

Approved By:

Signature _____

Name _____

Date _____

TAFT ELECTRIC CHANGE ORDER REQUEST

PROJECT: Lemonwood ES JOB# 2241

TEC COR#: 005 R1

CUST RFP#: _____

COR DESCRIPTION: MSB-9 Credit (1)3/4", add (2)5"

DATE: 8/2/2016

See TEC RFI 003R1

| DESCRIPTION | TAKE OFF | |
|-----------------------|--------------------|---------------|
| | MATERIAL | HOURS |
| Conest (see attached) | \$14,103.15 | 112.54 |
| | \$0.00 | 0.00 |
| | \$0.00 | 0.00 |
| | \$0.00 | 0.00 |
| | \$0.00 | 0.00 |
| | \$0.00 | 0.00 |
| | \$0.00 | 0.00 |
| | \$0.00 | 0.00 |
| | \$0.00 | 0.00 |
| | \$0.00 | 0.00 |
| | \$0.00 | 0.00 |
| | \$0.00 | 0.00 |
| | \$0.00 | 0.00 |
| | \$0.00 | 0.00 |
| | \$0.00 | 0.00 |
| | \$0.00 | 0.00 |
| TOTAL | \$14,103.15 | 112.54 |

| LABOR EXPENSES | | | |
|------------------------------|--------|---------|--------------------|
| TYPE | HOURS | RATE | AMOUNT |
| STRAIGHT TIME | 112.54 | \$83.65 | \$9,413.60 |
| DESIGNER | 7.00 | \$92.70 | \$648.90 |
| CAD OPERATOR | 3.00 | \$53.50 | \$160.50 |
| | 0.00 | \$0.00 | \$0.00 |
| | 0.00 | \$0.00 | \$0.00 |
| | 0.00 | \$0.00 | \$0.00 |
| SUBTOTAL LABOR | | | \$10,223.00 |
| 0.00% | | | \$0.00 |
| 0.00% | | | \$0.00 |
| 0.00% | | | \$0.00 |
| 0.00% | | | \$0.00 |
| 0.00% | | | \$0.00 |
| 0.00% | | | \$0.00 |
| 0.00% | | | \$0.00 |
| 0.00% | | | \$0.00 |
| 0.00% | | | \$0.00 |
| SUBTOTAL LABOR | | | \$10,223.00 |
| 15.00% | | | \$1,533.45 |
| OVERHEAD & PROFIT | | | \$1,533.45 |
| TOTAL LABOR | | | \$11,756.45 |

| TAKEOFF MATERIAL | | |
|-------------------------------|-------------------|--------------------|
| % | DESCRIPTION | AMOUNT |
| 3.00% | CONSUMABLES | \$423.09 |
| 8.00% | SALES TAX | \$1,162.40 |
| 3.00% | MATERIAL HANDLING | \$470.65 |
| 0.00% | | \$0.00 |
| SUBTOTAL MATERIAL | | \$16,158.99 |
| 15.00% | OVERHEAD & PROFIT | \$2,423.85 |
| TOTAL TAKEOFF MATERIAL | | \$18,582.84 |

| DIRECT JOB EXPENSES | | |
|---------------------|-------------------------|-------------------|
| % | DESCRIPTION | AMOUNT |
| 0.00% | AS BUILTS / O&M'S | \$0.00 |
| 0.00% | PERMIT FEES | \$0.00 |
| 0.00% | ESTIMATING | \$0.00 |
| 0.00% | CAD / DRAFTING | \$0.00 |
| 0.00% | REPRODUCTION COSTS | \$0.00 |
| 0.00% | | \$0.00 |
| 0.00% | EQUIPMENT RENTAL | \$0.00 |
| 0.00% | CRANE / FORKLIFT | \$0.00 |
| 0.00% | JOB TRUCK | \$0.00 |
| 0.00% | SAWCUT | \$265.00 |
| 0.00% | CONCRETE PUMP | \$1,050.00 |
| 0.00% | TRAFFIC CTRL/PED SAFETY | \$195.00 |
| 0.00% | TRENCH PLATES | \$245.00 |
| 0.00% | | \$0.00 |
| 0.00% | | \$0.00 |
| 0.00% | | \$0.00 |
| 0.00% | | \$0.00 |
| 0.00% | | \$0.00 |
| 0.00% | | \$0.00 |
| 0.00% | | \$0.00 |
| 0.00% | WARRANTY | \$0.00 |
| 0.00% | | \$0.00 |
| SUBTOTAL DJE | | \$1,755.00 |
| 15.00% | OVERHEAD & PROFIT | \$263.25 |
| TOTAL DJE | | \$2,018.25 |

| QUOTED MATERIAL | | |
|------------------------|-------------------------------|-----------------|
| VENDOR | DESCRIPTION | AMOUNT |
| Oldcastle | 4x4 Pullbox standard (credit) | (\$3,226.00) |
| | 4x4 Pullbox custom cast (add) | \$3,874.00 |
| | | \$0.00 |
| | | \$0.00 |
| | | \$0.00 |
| SUBTOTAL QUOTES | | \$648.00 |
| 8.00% | SALES TAX | \$51.84 |
| 3.00% | MATERIAL HANDLING | \$21.00 |
| 0.00% | | \$0.00 |
| 0.00% | | \$0.00 |
| SUBTOTAL QUOTES | | \$720.84 |
| 15.00% | OVERHEAD & PROFIT | \$108.13 |
| TOTAL QUOTES | | \$828.96 |

| CHANGE REQUEST SUMMARY | | |
|--------------------------------|-------------|--------------------|
| TAKEOFF MATERIAL | \$18,582.84 | |
| QUOTED MATERIAL | \$828.96 | |
| SUBCONTRACTORS | \$3,865.83 | |
| LABOR EXPENSES | \$11,756.45 | |
| DIRECT JOB EXPENSES | \$2,018.25 | |
| SUBTOTAL CHANGE REQUEST | | \$37,052.33 |
| 0.00% | \$0.00 | |
| 0.00% | \$0.00 | |
| 1.00% | \$370.52 | |
| CHANGE PROPOSAL TOTAL | | \$37,423 |

| SUBCONTRACTORS | | |
|------------------------------|-------------------|-------------------|
| VENDOR | DESCRIPTION | AMOUNT |
| DJS | CONCRETE | \$2,566.74 |
| PowerPlus | R&R Temp Pole | \$1,115.00 |
| | | \$0.00 |
| | | \$0.00 |
| | | \$0.00 |
| SUBTOTAL SUBCONTRACTS | | \$3,681.74 |
| 5.00% | OVERHEAD & PROFIT | \$184.09 |
| TOTAL SUBCONTRACTS | | \$3,865.83 |

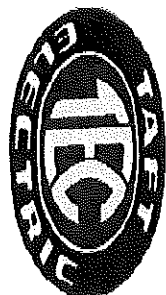

Takeoff

Vendor: COST

Labor Level: LABOR 1

2 Aug 2016 7:53:17

Region: COR 005 MSB-9 CONDUITS

| Item # | Qty | U/M | Q/M | Size | Description | Material Unit | Material Result | Labor Unit | Labor Result |
|----------------------|-------|-----|-----|----------------|--------------------------------------|------------------|-----------------|------------|---------------|
| 0 | | | | | CREDIT (1)3/4" -650' | | | | |
| 10074 | -650 | FT | M | 3/4 | PVC SCH 40 10' LAID IN TRENCH LBR. | 0.2821 | -183.37 | 0.0350 | -22.75 |
| 20001 | -2 | EA | M | 3/4 | PVC SCH 40 90-DEG ELBOW | 0.5848 | -1.17 | 0.2200 | -0.44 |
| 30311 | -4 | EA | M | 3/4 | PVC END BELLS | 0.0000 | 0.00 | 0.1400 | -0.56 |
| 30338 | -1 | EA | M | 3/4 | PVC CONDUIT CAP | 1.0934 | -1.09 | 0.1200 | -0.12 |
| 10 | -65 | M | M | 3/4 | POLYMER SUPPORT - PUNCHOUT | 0.0000 | 0.00 | 0.0400 | -2.60 |
| 40032 | -2 | EA | M | QUART | PVC (GLUE) CEMENT | 9.6462 | -19.29 | 0.2000 | -0.40 |
| 500125 | -670 | FT | M | | PULL ROPE 1/4" | 0.0708 | -47.46 | 0.0039 | -2.61 |
| | 0 | | | | ADD (2)5" -650' | | | | |
| 15 | 6 | EA | M | 5 | PVC SCH 40 90-DEG ELBOW 12R | 131.2349 | 787.41 | 1.5500 | 9.30 |
| 30320 | 8 | EA | M | 5 | PVC END BELLS | 7.1633 | 57.31 | 0.4500 | 3.60 |
| 40032 | 12 | EA | M | QUART | PVC (GLUE) CEMENT | 9.6462 | 115.75 | 0.2000 | 2.40 |
| 30353 | 2 | EA | M | 5 | PVC CONDUIT PLUG | 2.5772 | 5.15 | 0.3500 | 0.70 |
| 500125 | 1,340 | FT | M | | PULL ROPE 1/4" | 0.0708 | 94.93 | 0.0039 | 5.23 |
| 12 | 130 | M | M | 5 | POLYMER SUPPORT - PUNCHOUT | 0.0000 | 0.00 | 0.0700 | 9.10 |
| 13 | 130 | M | M | | POLYMER SUPPORT - MATERIAL PER SQ/FT | 2.2500 | 292.50 | 0.0000 | 0.00 |
| 19 | 4 | M | M | | REMOVE & REPLACE SC GRAVEL | 0.0000 | 0.00 | 1.0000 | 4.00 |
| 390123 | 410 | FT | M | 12" X 36" DEEP | BACKHOE TRENCH+BACKFILL | 3.5000 | 1,435.00 | 0.0200 | 8.20 |
| 16 | 240 | FT | M | 12" X 72" DEEP | BACKHOE TRENCH+BACKFILL | 7.5000 | 1,800.00 | 0.0200 | 4.80 |
| 390083 | 15 | FT | M | 12" WIDE | HAND TRIM SAND TRENCH | 0.0000 | 0.00 | 0.4500 | 6.75 |
| 10083 | 1,300 | FT | M | 5 | PVC SCH 40 10' LAID IN TRENCH LBR. | 4.0104 | 5,213.48 | 0.0575 | 74.75 |
| 390429 | 44 | VD | M | 2 SACK SLURRY | CONCRETE ENCASUREMENT | 103.5000 | 4,554.00 | 0.3000 | 13.20 |
| Phase Totals: | | | | | | 14,103.15 | | | 112.54 |
| Job Totals: | | | | | | 14,103.15 | | | 112.54 |

Taft Electric Company

1694 Eastman Avenue
 Ventura, CA 93003

Phone: 805-642-0121
 Web: www.taftelectric.com



Confirmation copy

Confirmation No: SC137668

10650 HEMLOCK AVE
FONTANA, CA 92337 7296

Telephone.: 909-428-3700
Fax.....: 909-428-3737

www.oldcastleprecast.com

Sold To Taft Electric Co
PO BOX 3416
VENTURA, CA 93006 3416

Ship To OXNARD - 2241 LEMONWOOD
AVE (REBID 148736)
OXNARD, CA 93030 5108

Ship date: 6/1/2016

Reference.: MATT

Contact:

Phone:

| S177206 | Date | Customer No | Customer PO | Terms | Cash discount | Delivery terms |
|---------|----------|-------------|-------------|-------------|---------------|----------------|
| | 8/1/2016 | 001265 | 222847 | Net 45 Days | | FOB Job Site |

| Qty | Unit | Item | Description | Mark | Unit price | Amount |
|------|------|---------|--|------|------------|----------|
| 1.00 | Ea | 0000001 | POWER 44-102 FW w/ TRAFFIC DP BOLT DOWN FRAME & COVER & RACKING (4'x4'x8'6") | | 3,874.00 | 3,874.00 |
| 1.00 | Ea | 0100020 | 44-30 Flat Wall Base w/ 2 @ 20" x 30" THINWALL KNOCKOUTS ON OPPOSITE SIDE WALLS | | | |
| 1.00 | Ea | 0100145 | 44-18 TXF Top w/ BLTDN Frame | | | |
| 1.00 | Set | 2350080 | "POWER" 44 Traffic Galv Diamond Plate Boltdown Cover Set | | | |
| .00 | Ea | 0100130 | 44-24 Riser | | | |
| .00 | Ea | 0100105 | 44-06 Riser 6" walls | | | |

Confirmation copy

Confirmation No: SC137428

 10650 HEMLOCK AVE
 FONTANA, CA 92337 7296

 Telephone.: 909-428-3700
 Fax.....: 909-428-3737

www.oldcastleprecast.com

Sold To: Taft Electric Co
 PO BOX 3416
 VENTURA, CA 93006 3416

Ship To ...: OXNARD - 2241 LEMONWOOD
 AVE (REBID 148736)
 OXNARD, CA 93030 5108

Ship date: 6/1/2016

Reference .: MATT

Contact:
Phone:

| S177206 | Date | Customer No | Customer PO | Terms | Cash discount | Delivery terms |
|---------|-----------|-------------|-------------|-------------|---------------|----------------|
| | 7/27/2016 | 001265 | 222847 | Net 45 Days | | FOB Job Site |

| Qty | Unit | Item | Description | Mark | Unit price | Amount |
|------|------|---------|---|------|------------|----------|
| 1.00 | Ea | 0000001 | POWER 44-102 FW w/ TRAFFIC DP BOLT DOWN FRAME & COVER & RACKING (4'x4'x8'6") | | 3,226.00 | 3,226.00 |
| 1.00 | Ea | 0100020 | 44-30 Flat Wall Base | | | |
| 1.00 | Ea | 0100145 | 44-18 TXF Top w/ BLTDN Frame | | | |
| 1.00 | Set | 2350080 | "POWER" 44 Traffic Galv Diamond Plate Boltdown Cover Set | | | |
| 2.00 | Ea | 0100130 | 44-24 Riser | | | |
| 1.00 | Ea | 0100105 | 44-06 Riser 6" walls | | | |
| 1.00 | Ea | 2900230 | 44 Racking Package | | | |
| 1.00 | \$ | 9400010 | FOB Jobsite (non taxable) | | | |

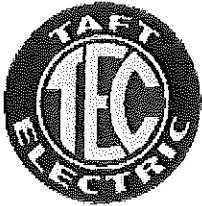

Taft Electric Company

1694 Eastman Avenue
Ventura, CA 93003
(805)642-0121
Contractor License # 772245

TEC RFI 003 R001

Detailed, RFIs without Routing Information Grouped by RFI Number

2241 Lemonwood

Project # 2241
Tel: Fax:

TAFT ELECTRIC COMPANY

RFI #: 003 R001

Date Created: 6/30/2016

| RFI Issued To: | Contact Name | Author Company | Authored By |
|---|----------------|---|-------------|
| Swinerton Builders 865 S. Figueroa Street Los Angeles, CA 90017 | Nalani Scanlon | TAFT ELECTRIC COMPANY P.O. Box 3416 Ventura, CA 93006 | Matt Gobuty |

| RFI Answered By: | Owner RFI Number |
|------------------|------------------|
| | |

| Subject | Discipline | Category |
|-----------------------|------------|----------|
| MSB-9 Future Conduits | Electrical | |

| Cost Impact | Amount | Sched Impact | Days | Dwg Impact |
|-------------|--------|--------------|------|------------|
| Not Sure | | Not Sure | | Not Sure |

| Cost Impact Comments | Sched Impact Comments | Dwg Impact Comments |
|----------------------|-----------------------|---------------------|
| | | |

| Cc: Company Name | Contact Name | Copies | Notes |
|------------------|--------------|--------|-------|
| | | | |

Question **Date Required:**

On E5.1 Single Line Distribution Diagram, MSB-9 shows (2) 5" conduits for future use. On E1.1.0 at the Northwest corner of Classroom Building 1, there is a terminated conduit marked MSB-7, indicating that it is a 3/4" for future irrigation. We believe this is incorrect and should be marked MSB-9 indicating the (2)5" for future power. Please confirm (see attached sketch).

Suggestion

Answer **Date Answered:**

| | |
|--|---|
| <p>Author: Andrea Lawson Confirmed. MSB-7 should be MSB-9 at the NW corner of Bldg 1.</p> | <p>Date: 07/13/2016 09:06 AM</p> |
|--|---|

From: Nalani Scanlon <NScanlon@swinerton.com>
Sent: Thursday, July 14, 2016 9:33 AM
To: Matt Gobuty
Cc: Bill Gray
Subject: RE: 2241 Lemonwood TEC RFI 003R1 MSB-9 conduits - CRITICAL

Importance: High

Matt,

Due to the Architect being out of the office for a week, the RFI will not be officially answered in the system until his return. However, due to the critical nature of procurement, please proceed with the answer noted by the EEOR.

Thanks,

Nalani Scanlon

Senior PE | SWINERTON BUILDERS

865 S. Figueroa Street, Suite 3000 | Los Angeles, CA 90017

T 213.896.3480 | C 213.334.1807 | www.swinerton.com

JOBSITE OFFICE: 2200 Carnegie Ct., Oxnard, CA 93033

nscanlon@swinerton.com

125

INTEGRITY | LEADERSHIP | PASSION | EXCELLENCE

From: Matt Gobuty [mailto:mgobuty@taftelectric.com]
Sent: Thursday, July 14, 2016 9:08 AM
To: Nalani Scanlon
Cc: Bill Gray; Scott Augustine
Subject: 2241 Lemonwood TEC RFI 003R1 MSB-9 conduits - CRITICAL

Good morning,

I noticed that this RFI is potentially answered, but I haven't seen a response and the status remains OPEN. **This RFI answer is CRITICAL to our installation.** To meet the schedule we must release underground pullboxes & custom fabbed conduit supports for this ductbank no later than tomorrow.

If possible, please expedite this RFI and provide us with an official answer no later than tomorrow, Friday 7/15

Thank you

RFI No. 00024R1
 From: Nalani Scanlon
 Co-Author: Matt Gobuty
 Forwarded From: TAFT-00009
 To: Tom Bardwell
 CC: Bill Voller, Paul Vernier
 Subject: TEC RFI 003 R1
 Date Created: 2016-07-11
 RFI Type: Electrical
 Schedule / Activity ID:
 Spec Section:
 Other RFI Type:

Source

Question: **On E5.1 Single Line Distribution Diagram, MSB-9 shows (2) 5" conduits for future use. On E:**
incorrect and should be marked MSB-9 indicating the (2)5" for future power. Please confirm

Suggestion: **Confirm that conduit marked MSB-7 should be MSB-9 (@NW corner of BLDG 1)**

Possible Cost Impact: Potentially

Possible Time Impact: Potentially

Answered By:

Date Answered:

Answer:

Sort

Author: Andrea Lawson

Date: 07/13/2016 09:06 AM

Confirmed. MSB-7 should be MSB-9 at the NW corner of Bldg 1.

Author: Nalani Scanlon

Date: 07/11/2016 11:02 AM

Forwarded by Nalani Scanlon to Tom Bardwell as 00024R1

Matt Gobuty

Project Manager

Taft Electric

(805) 654-7994

mgobuty@taftelectric.com

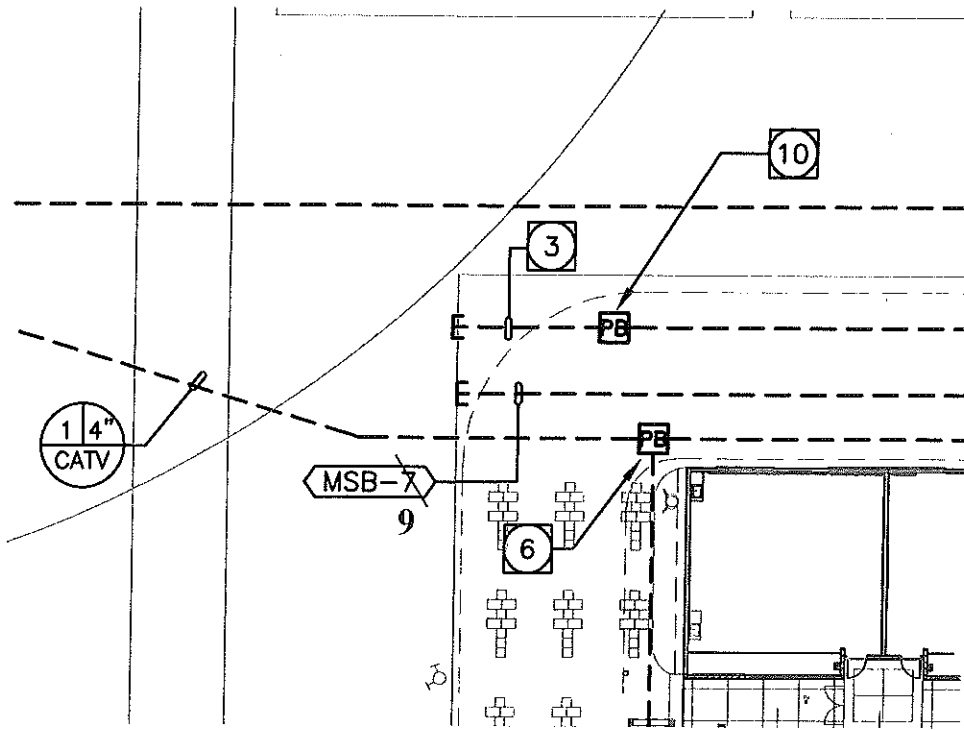

| | | | | | | | |
|-------|-------------------|---|---|---|---|---|-------------------|
| MSB-9 | (2) 4"C.O. FUTURE | - | - | - | - | - | (2) 5"C.O. FUTURE |
|-------|-------------------|---|---|---|---|---|-------------------|

SCE CONDUIT ROUTING

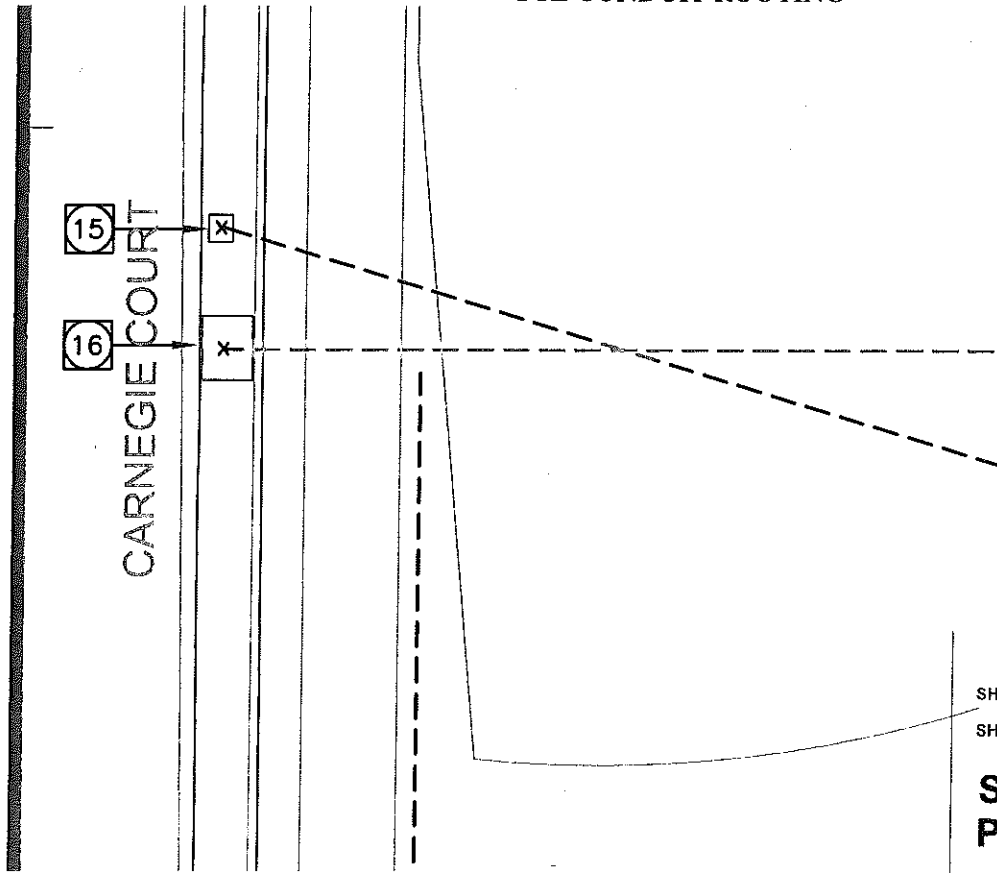

SHEET NUMBER: **E1.1.0**

SHEET TITLE: _____

SITE UTILITY PLAN

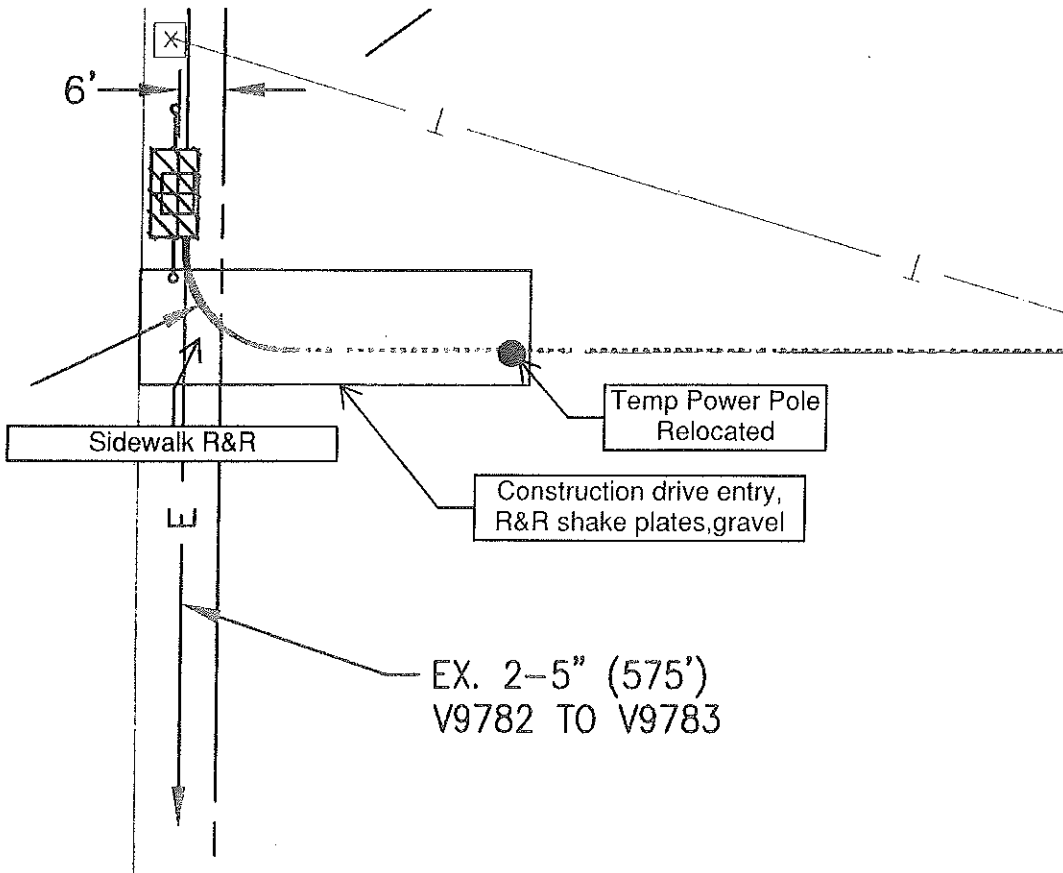

DJS Contracting, Inc.

PO Box 841080 140 • Simi Valley, CA 90984-1080

Phone: (805) 584-2714 • Fax: (805) 584-2023

License # 776402

COST PROPOSAL

| | |
|---------------|---------|
| Cost Proposal | 7/27/16 |
| Date | 7/27/16 |
| DJS COR # | |

General Contractor:
Taft Electric Company
 PO Box 3416
 Ventura, CA 93006

Job:
Lemonwood School in Oxnard
 2200 Carnegie CT.

| | |
|---------------------|---|
| Description: | Concrete replacement of approx. 5' wide by 28' long of existing city sidewalk. Includes fees and time for labor compliance. |
| | |
| | |

LABOR CHARGES

| DATE | CLASSIFICATION | DESCRIPTION | NO. | TYPE | HRS | TOT. HRS | RATE | TOTAL |
|--------------------|-------------------|--------------------------------------|-----|------|------|----------|----------|--------------------|
| | Carpenter Foreman | Form, place and finish | 1 | ST | 8.00 | 8.00 | \$ 69.52 | \$ 556.16 |
| | Labor | Form, place and finish | 1 | ST | 8.00 | 8.00 | \$ 59.58 | \$ 476.64 |
| | Superintendent | Supervision and coordination of work | 1 | ST | 4.00 | 4.00 | \$ 75.00 | \$ 300.00 |
| | Clerical | Labor compliance | 1 | ST | 4.00 | 4.00 | \$ 36.56 | \$ 146.24 |
| TOTAL LABOR | | | | | | | | \$ 1,479.04 |

SUBCONTRACTOR

| DATE | CLASSIFICATION | DESCRIPTION | QTY | RATE | AMOUNT |
|----------------------------|----------------|-------------|-----|------|-------------|
| | | | | | \$ - |
| TOTAL SUBCONTRACTOR | | | | | \$ - |

MATERIALS AND EQUIPMENT

| DATE | CLASSIFICATION | DESCRIPTION | QTY | RATE | AMOUNT |
|--------------------------------------|----------------|---|------|-----------|------------------|
| | Labor | Concrete (Includes short load fees) 3 cubic yards | 3.00 | \$ 155.00 | \$ 465.00 |
| | Equipment | DJS Truck Allowance: Fuel and tool use | 1.00 | \$ 85.00 | \$ 85.00 |
| TOTAL MATERIALS AND EQUIPMENT | | | | | \$ 550.00 |

SUMMARY

| | | | | |
|--|--------------|--------|--|--------------------|
| TOTAL LABOR COSTS | | | | \$ 1,479.04 |
| | Profit | 15.00% | | \$ 221.86 |
| | TOTAL | | | \$ 1,700.90 |
| TOTAL MATERIAL & EQUIP. COSTS | | | | \$ 550.00 |
| | Profit | 15.00% | | \$ 82.50 |
| | TOTAL | | | \$ 632.50 |
| SUBTOTAL LABOR, MATERIAL, EQUIPMENT | | | | \$ 2,333.40 |
| | Overhead | 10.00% | | \$ 233.34 |
| | TOTAL | | | \$ 2,566.74 |
| TOTAL SUBCONTRACTOR | | | | \$ - |
| | Mark up | 5.00% | | \$ - |
| | TOTAL | | | \$ - |
| TOTAL LABOR, MATERIAL, EQUIPMENT & SUBCONTRACTORS | | | | \$ 2,566.74 |
| | Bond | 0.0% | | \$ - |
| CHANGE ORDER TOTAL | | | | \$ 2,566.74 |



Utility Services
1210 N. Red Gum Street
Anaheim, CA 92806

Corporate / Accounting
(714) 507-1881
(714) 630-3440

Customer Service / Scheduling
(800) 863-2525

Fed. Tax ID # 26-4729378

Customer's NAME AND ADDRESS
15411 ...
CITY, STATE, ZIP
CITY, STATE, ZIP

PARKING SLIP

CD S M
LA ANUBAN

1-14-14 ...

Additional Service and Schedule
Remarks: None

INITIALS AND SIGNATURE

Date:

City/State:

Customer's Name:

Phone:

Signature: [Handwritten Signature]
Date: [Handwritten Date]

Time of Day: [Handwritten Time]
Day of Week: [Handwritten Day]
Month/Year: [Handwritten Month/Year]

Form completed by Utility Services on 07/24/14 at 10:00 AM

PHI LEGAL INFORMATION

THIS IS A LEGAL DOCUMENT. PLEASE READ IT CAREFULLY.

Table with columns: No., Description, Amount, Total. Contains financial data related to the rental agreement.

Total amount due is \$4,000.00

TERMS AND CONDITIONS

LESSEE AGREES TO PROVIDE THE FOLLOWING:

- 1. Provide Lessor with exact pole locations prior to installation and/or relocation of poles and hold Lessor harmless of damage to underground utilities.
2. For poles that need to be hand set or hand pulled, there will be a minimum charge of \$20.00 per pole.
3. Payment of all electric bills.
4. Payment for damaged or missing equipment.
5. Payment for relocating equipment.
6. Payment for special equipment needed for severe rigging conditions.

LESSEE AGREES THAT:

Lessor shall not be responsible for power surges, loss of power, outages, shorts in line, nor Lessor warrant or guarantee voltage or amperage amounts or capacities. Lessor shall be responsible for damage to property, including but not limited to saws, hand tools, compressors, clocks, phone, radio, computers, copiers, etc.

- 1. All rentals under this agreement are payable upon receipt of invoice. Rental starts immediately upon delivery to Lessee at Lessor's warehouse and shall continue until the rental period set forth in this agreement has expired or until Lessee has notified Lessor in writing of his intent to terminate this agreement, whichever is later.
2. In the event any equipment is damaged or missing, Lessee shall pay to Lessor the reasonable replacement value of said equipment to be determined at the sole discretion of the Lessor.
3. Lessee shall not utilize the leased equipment beyond its rated electrical capacity.
4. Lessee shall indemnify, defend and hold harmless against all claims, demands and liabilities of every nature arising from Lessee's utilization of the equipment under this agreement, unless solely caused by the negligence or misconduct of the Lessor as long as the injury is caused in part by the negligence or misconduct of Lessee or by his employees, agent or other related entities.
5. In the event of a disagreement arising out of this agreement, the prevailing party will be entitled to reasonable attorney's fees.

Payments shall be made by Lessee upon receipt of an invoice from Lessor. Lessor reserves the right to discontinue service to any delinquent account. Lessee agrees to pay a processing fee of 1.5% of the unpaid balance. Should Lessor receive a payment Lessee noted "payment in full", or a similar phrase, the payment will be applied to Lessee's account. However, Lessor's processing of the payment does not relieve Lessee of any obligation to pay remaining balances on Lessee's account. Lessor honors Lessee's request for equipment pick up on the date the request is made, therefore, the charges for such request shall not be subject to any proration.

Handwritten signatures and dates at the bottom of the page.



January 20, 2017

Oxnard School District
1051 South A Street
Oxnard, CA, 93030

Attn: Ms. Marlene Hickle, CFW Inc.

Subject: Swinerton Builders Job 16055106 - Lemonwood K-8 School LLB
PCI No. 0086 Add Hub drains for Fire Sprinkler drain

2/7/17 approved but is it OCA or OCO??
2/7/17
~~*CCP to re-visit cost w/ roof drains.*~~
mk 2/7/17
Revisit

Dear Ms. Hickle,

We request a Change Order to our contract for the following:

Bldgs. 3, 4 and 5 were not designed with the hub drains for the FS system. Bulletin #35 added these to each bldg.

| Phase | Category | Description | Subcontractor | Quote |
|--------|----------|---|--------------------------------|------------------|
| 220010 | 71140 | Bldgs. 3, 4 and 5 were not designed with the hub drains for the FS system. Bulletin #35 added these to each bldg. | CITY COMMERCIAL PLUMBING, INC. | 17,814.00 |
| | | | Subtotal | 17,814.00 |
| 007480 | 71160 | Subguard | 1.15% | 204.86 |
| 007410 | 71160 | Builders Risk | 0.6% | 108.11 |
| 007420 | 71160 | General Insurance | 1.15% | 207.22 |
| 007510 | 71160 | P&P Bond | 1% | 178.14 |
| 991000 | 79999 | Change Order Fee | 5% | 916.71 |
| | | | Markup Subtotal | 1,615.04 |
| | | | PCI Total | 19,429.04 |

TOTAL AMOUNT OF THIS CHANGE ORDER REQUEST: **19,429.04.**

Please NOTE:

- » The incorporation of this revision in to the contractual scope of work may have an impact on our schedule and cost, which is yet to be finalized. Once determined, the job schedule and cost will be adjusted accordingly to show the effect of this revision on the final project completion date.
- » The terms (cost and schedule impact) of this change order request are subject to review and a requote if not accepted within 5 days of its issuance.
- » This request does not include additional cost or delay due to late approval.

We **HAVE NOT** proceeded with this revised work per your instructions. Please issue a change order.

2/7/17 mk *TB 2/7/17*



Upon acceptance of this change order request, a formal change order will be issued. Acceptance also acknowledges that Swinerton Builders is directed to proceed with the above change in scope.

If you have any questions or comments pertaining to this matter, please contact the undersigned.

Sincerely,
Swinerton Builders

Bill Gray
PM
Date: _____

1/20/2017

Quotation accepted by:
Oxnard School District

By: _____

Date: _____



CITY COMMERCIAL PLUMBING, INC.
Plumbing Contractors and Consultants

16106 Cohasset St., Van Nuys, California 91406

(818) 785-1145

Fax: (818) 785-0588

EXTRA WORK ORDER SUBMITTAL

January 9, 2017

TO: SWINERTON BUILDERS

ATTENTION: BILL GRAY

JOB NAME: LEMONWOOD K-8

EXTRA WORK ORDER NO: CCP Inc., C.O.R.#27-R

DESCRIPTION: BULLETIN#35 - ADD HUB DRAINS AND RELATED PIPING AT MPR, ADMIN AND KINDERGARTEN BUILDINGS.

TOTAL COST: \$17,814.00

Escalation rate of 1.5% / month will apply all unpaid change orders. Change order pricing assumes conditions existing as of date submitted. We reserve the right to adjust pricing if conditions change. Change orders should not be subject to retention. Request 5 days extension to complete this change order. We reserve the right to assess the cumulative impact of change.

This is the cost to add the scope to our contract. This proposal is void unless a written Change Order is received within 30 calendar days from the date of this Extra Work Order Submittal. Please send a Subcontract Change Order if you would like us to proceed with the extra work. This change order represents the work described only in this proposal. If the proposal is incomplete, we reserve the right to revise our price. We encourage you to review the scope of work we are offering to make sure it is in line with the changes.

If an owner-initiated change order is not accepted and authorized, City Commercial Plumbing demands reimbursement for all costs incurred in the preparation of the quote. If you have any questions or need clarification please call.

Sincerely,
CITY COMMERCIAL PLUMBING, INC

Cindy Snyder, Project Manager

Enclosures

CHANGE ORDER REQUEST

01/11/2017

CITY COMMERCIAL PLUMBING, INC.

16106 COHASSET STREET
 VAN NUYS, CA 91406
 (818) 785-1145

CONTRACTOR: SWINERTON BUILDERS
 17731 MITCHELL NORTH, SUITE 200
 IRVINE, CA 92614

JOB NAME: LEMONWOOD K-8
 2200 CARNEGIE COURT
 OXNARD, CA 93033

CCP JOB NO.: 562

CHANGE ORDER NO. 27-R

RE: BULLETIN #35 ADD HUB DRAINS AT MPR, ADMIN & KINDER BLDGS

| LABOR: | WAGES | HOURS | TOTAL |
|--------------------------|--------|-------|--------------------|
| GEN FOREMAN | 103.24 | 12.00 | 1,238.88 |
| PLUMBER | 87.39 | 74.36 | 6,498.32 |
| TOTAL LABOR: | | | 7,737.20 |
| OTHER EXPENSE: | | | |
| BACKHOE | 135.00 | 2.00 | 270.00 |
| BACKHOE W. WHL | 157.00 | 4.00 | 628.00 |
| FREIGHT FOR FLEXTEND | | | 50.00 |
| TOTAL OTHER EXP.: | | | 948.00 |
| OTHER EXPENSE: | | | 948.00 |
| MATERIAL TOTAL: | | | 6,776.98 |
| LABOR TOTAL: | | | 7,737.20 |
| SUBTOTAL: | | | 15,462.18 |
| OVERHEAD/PROFIT: | 15.00% | | 2,319.33 |
| SUBTOTAL: | | | 17,781.50 |
| TEXTURA FEES: | 0.18% | | 32.01 |
| SUBTOTAL: | | | 17,813.51 |
| | | | 0.00 |
| | | | 17,813.51 |
| ROUND UP/DOWN: | | | \$17,814.00 |

NOTES:

U.S.

CHANGE ORDER REQUEST

01/11/2017

CITY COMMERCIAL PLUMBING, INC.

MATERIAL LIST

JOB: LEMONWOOD K-8
2200 CARNEGIE COURT
OXNARD, CA 93033

CCP JOB NO.: 562
CHANGE ORDER NO. 27-R

RE: BULLETIN #35 ADD HUB DRAINS AT MPR, ADMIN & KINDER BLDGS

| QTY. | U/M | MATERIAL NAME | LAB U. | T. LAB. | MAT.COST | T. MAT |
|-----------------------------------|-----|---|--------|--------------|--------------|----------------|
| | | BUILDING 2 COST | | 24.98 | | ✓ 2112.76 |
| | | BUILDING 3 COST | | 15.34 | | ✓ 2281.78 |
| | | BUILDING 4 COST | | 30.84 | | ✓ 1957.65 |
| | | BUILDING 4 CREDIT | | -2.80 | | -134.78 |
| | | BACKHOE W. OPERATOR (2 HR - SEE OTHER EXPENSE) | | | | |
| | | BACKHOE COMPACT W. OPERATOR (4 HRS - SEE OTHER EXPENSE) | | | | |
| | | PLUMBER WORK WITH BACKHOE | | 6.00 | | |
| | | GEN FOREMAN - LAYOUT/COORDINATE | | 6.00 | | |
| | | GEN FOREMAN - CADD | | 6.00 | | |
| LABOR & MATERIAL TOTAL | | | | 86.36 | | 6217.41 |
| SALES TAX: | | | | | 9.00% | 559.57 |
| TOTAL MATERIAL COST: | | | | | | 6776.98 |

JOB 994 562COR: 562 - LEMONWO...
 ESTIMATE 1 562COR: LEMONWOOD K-...
 DATA SET 2 MECH DATABASE 12-31-16

COR#27, BUILDING 2
 CITY COMMERCIAL PLUMBING
 16106 COHASSET ST.
 VAN NUYS, CA 91406
 818-785-1145 / (Company Fax)
 CSNYDER@CCPINC.NET

PRINTED 1/9/2017 4:55:26 PM
 MATERIAL Primary
 LABOR Alternate

NOTES

| Item | | | | Material | | Field Labor | | |
|--------|----------|------|-----------|----------|----------|-------------|----------|---------|
| Item # | Category | Size | Item Desc | Qty | Mat Unit | Mat Ext | Fid Unit | Fid Ext |

Section : Section 044: COR#27 - BULL#35 HUB DRAINS/PIPING B2

Category : Category 049: HANGER-R.CLAMP-ETC.

| | | | | | | | | |
|----------|--------------------|--------|-------------------|----|------|-------|------|------|
| 49010006 | HANGER-R.CLAMP-... | 2" | CLEVIS HGR.-BLK. | 3 | 2.10 | 6.30 | 0.50 | 1.50 |
| 49090001 | HANGER-R.CLAMP-... | 7/8" | STRUT CHANNEL | 2 | 2.68 | 5.36 | 0.12 | 0.24 |
| 49090002 | HANGER-R.CLAMP-... | 1-5/8" | STRUT CHANNEL | 3 | 3.16 | 9.48 | 0.12 | 0.36 |
| 49150013 | HANGER-R.CLAMP-... | 2-5/8" | STRUT CLAMP | 2 | 2.83 | 5.66 | 0.10 | 0.20 |
| 49150019 | HANGER-R.CLAMP-... | 6" | STRUT CLAMP | 1 | 7.03 | 7.03 | 0.20 | 0.20 |
| 49150024 | HANGER-R.CLAMP-... | 4-3/8" | STRUT CLAMP | 1 | 4.58 | 4.58 | 0.15 | 0.15 |
| 49380002 | HANGER-R.CLAMP-... | 3/8" | ALL THREAD ROD | 20 | 1.08 | 21.60 | Skip | 0.00 |
| 49400002 | HANGER-R.CLAMP-... | 3/8" | HEX NUTS | 14 | 0.79 | 11.06 | Skip | 0.00 |
| 49410002 | HANGER-R.CLAMP-... | 3/8" | WASHER-FLAT-ROUND | 14 | 0.26 | 3.64 | Skip | 0.00 |
| 49460001 | HANGER-R.CLAMP-... | 3/8" | Q-DECK INSERT | 3 | 4.87 | 14.61 | 0.40 | 1.20 |

Subtotals for Category : Category 049: HANGER-R.CLAMP-ETC.

89.32

3.85

Category : Category 050: C.I. SOIL NO HUB HEAVY DUTY

| | | | | | | | | |
|----------|------------------------|--------|---------------------------|----|--------|--------|------|------|
| 105 | C.I. SOIL NO HUB HE... | | 4" BRASS PLUG RAISED HEAD | 1 | 15.64 | 15.64 | 0.05 | 0.05 |
| 50010002 | C.I. SOIL NO HUB HE... | 2" | PIPE-C.I. NO HUB | 20 | 11.17 | 223.40 | 0.12 | 2.40 |
| 50010004 | C.I. SOIL NO HUB HE... | 4" | PIPE-C.I. NO HUB | 10 | 20.01 | 200.10 | 0.20 | 2.00 |
| 50010006 | C.I. SOIL NO HUB HE... | 6" | PIPE-C.I. NO HUB | 10 | 34.39 | 343.90 | 0.27 | 2.70 |
| 50020004 | C.I. SOIL NO HUB HE... | 4" | P-TRAP | 1 | 93.10 | 93.10 | 0.88 | 0.88 |
| 50050002 | C.I. SOIL NO HUB HE... | 2" | 1/8 BEND | 1 | 14.20 | 14.20 | 0.38 | 0.38 |
| 50060002 | C.I. SOIL NO HUB HE... | 2" | 1/4 BEND | 1 | 16.50 | 16.50 | 0.39 | 0.39 |
| 50060004 | C.I. SOIL NO HUB HE... | 4" | 1/4 BEND | 1 | 34.00 | 34.00 | 0.78 | 0.78 |
| 50100004 | C.I. SOIL NO HUB HE... | 4" | COMBINATION | 1 | 72.70 | 72.70 | 1.19 | 1.19 |
| 50110002 | C.I. SOIL NO HUB HE... | 2" | WYE | 1 | 21.00 | 21.00 | 0.56 | 0.56 |
| 50120004 | C.I. SOIL NO HUB HE... | 4" | SANITARY TEE | 1 | 53.00 | 53.00 | 1.11 | 1.11 |
| 50240006 | C.I. SOIL NO HUB HE... | 6" | BLIND PLUG | 1 | 36.10 | 36.10 | 0.55 | 0.55 |
| 50250004 | C.I. SOIL NO HUB HE... | 4" | SLEEVE-CRETE | 1 | 14.00 | 14.00 | 0.50 | 0.50 |
| 50280002 | C.I. SOIL NO HUB HE... | 2" | COUPLING-N.H. HEAVY DUTY | 8 | 18.30 | 146.40 | 0.10 | 0.80 |
| 50280004 | C.I. SOIL NO HUB HE... | 4" | COUPLING-N.H. HEAVY DUTY | 17 | 24.60 | 418.20 | 0.10 | 1.70 |
| 50280006 | C.I. SOIL NO HUB HE... | 6" | COUPLING-N.H. HEAVY DUTY | 1 | 42.80 | 42.80 | 0.10 | 0.10 |
| 50350003 | C.I. SOIL NO HUB HE... | 4" | SHORT SWEEP 1/4 BEND | 1 | 53.10 | 53.10 | 0.80 | 0.80 |
| 50430003 | C.I. SOIL NO HUB HE... | 4" x2" | REDUCER-SHORT | 1 | 17.90 | 17.90 | 0.54 | 0.54 |
| 50430009 | C.I. SOIL NO HUB HE... | 6" x4" | REDUCER-SHORT | 1 | 48.20 | 48.20 | 0.88 | 0.88 |
| 50460003 | C.I. SOIL NO HUB HE... | 4" | TEST TEE-LESS PLUG | 1 | 59.20 | 59.20 | 0.82 | 0.82 |
| 50590004 | C.I. SOIL NO HUB HE... | 4" | FIRESTOPPING | 1 | 100.00 | 100.00 | 2.00 | 2.00 |

Subtotals for Category : Category 050: C.I. SOIL NO HUB HEAVY DUTY

2,023.44

21.13

Subtotals for Section : Section 044: COR#27 - BULL#35 HUB DRAINS/PIPING B2

2,112.76

24.98

Grand Totals

2,112.76

24.98

JOB 994 562COR: 562 - LEMONWO...
 ESTIMATE 1 562COR: LEMONWOOD K-...
 DATA SET 2 MECH DATABASE 12-31-16

COR#27, BUILDING 3
 CITY COMMERCIAL PLUMBING
 16106 COHASSET ST.
 VAN NUYS, CA 91406
 818-785-1145 / (Company Fax)
 CSNYDER@CCPINC.NET

PRINTED 1/9/2017 4:58:48 PM
 MATERIAL Primary
 LABOR Alternate

NOTES

| Item | | | | Material | | Field Labor | | |
|--|------------------------|--------|--------------------------|----------|----------|-----------------|----------|--------------|
| Item # | Category | Size | Item Desc | Qty | Mat Unit | Mat Ext | Fid Unit | Fid Ext |
| Section : Section 045: COR#27 - BULL#35 HUB DRAINS/PIPING B3 | | | | | | | | |
| Category : Category 000: (None) | | | | | | | | |
| 103 | | | FLEXTEND | 1 | 1294.67 | 1,294.67 | 1.00 | 1.00 |
| Subtotals for Category : Category 000: (None) | | | | | | 1,294.67 | | 1.00 |
| Category : Category 049: HANGER-R.CLAMP-ETC. | | | | | | | | |
| 102 | HANGER-R.CLAMP-... | | SAMMY ANCHORS WSG 25-380 | 3 | 1.40 | 4.20 | 0.40 | 1.20 |
| 49010006 | HANGER-R.CLAMP-... | 2" | CLEVIS HGR.-BLK | 3 | 2.10 | 6.30 | 0.50 | 1.50 |
| 49090002 | HANGER-R.CLAMP-... | 1-5/8" | STRUT CHANNEL | 2 | 3.16 | 6.32 | 0.12 | 0.24 |
| 49150004 | HANGER-R.CLAMP-... | 7/8" | STRUT CLAMP CHANNEL | 2 | 2.68 | 5.36 | 0.12 | 0.24 |
| 49150019 | HANGER-R.CLAMP-... | 6" | STRUT CLAMP | 1 | 7.03 | 7.03 | 0.20 | 0.20 |
| 49150024 | HANGER-R.CLAMP-... | 4-3/8" | STRUT CLAMP | 1 | 4.58 | 4.58 | 0.15 | 0.15 |
| 49380002 | HANGER-R.CLAMP-... | 3/8" | ALL THREAD ROD | 10 | 1.08 | 10.80 | Skip | 0.00 |
| 49390002 | HANGER-R.CLAMP-... | 3/8" | ROD COUPLING | 4 | 1.75 | 7.00 | Skip | 0.00 |
| 49400002 | HANGER-R.CLAMP-... | 3/8" | HEX NUTS | 18 | 0.79 | 14.22 | Skip | 0.00 |
| 49410002 | HANGER-R.CLAMP-... | 3/8" | WASHER-FLAT-ROUND | 18 | 0.26 | 4.68 | Skip | 0.00 |
| 49490001 | HANGER-R.CLAMP-... | Unsize | SCREWS | 4 | 0.43 | 1.72 | Skip | 0.00 |
| Subtotals for Category : Category 049: HANGER-R.CLAMP-ETC. | | | | | | 72.21 | | 3.53 |
| Category : Category 050: C.I. SOIL NO HUB HEAVY DUTY | | | | | | | | |
| 50010002 | C.I. SOIL NO HUB HE... | 2" | PIPE-C.I. NO HUB | 20 | 11.17 | 223.40 | 0.12 | 2.40 |
| 50010004 | C.I. SOIL NO HUB HE... | 4" | PIPE-C.I. NO HUB | 10 | 20.01 | 200.10 | 0.20 | 2.00 |
| 50020004 | C.I. SOIL NO HUB HE... | 4" | P-TRAP | 1 | 93.10 | 93.10 | 0.88 | 0.88 |
| 50050002 | C.I. SOIL NO HUB HE... | 2" | 1/8 BEND | 1 | 14.20 | 14.20 | 0.38 | 0.38 |
| 50060002 | C.I. SOIL NO HUB HE... | 2" | 1/4 BEND | 2 | 16.50 | 33.00 | 0.39 | 0.78 |
| 50240006 | C.I. SOIL NO HUB HE... | 6" | BLIND PLUG | 1 | 36.10 | 36.10 | 0.55 | 0.55 |
| 50280002 | C.I. SOIL NO HUB HE... | 2" | COUPLING-N.H. HEAVY DUTY | 5 | 18.30 | 91.50 | 0.10 | 0.50 |
| 50280006 | C.I. SOIL NO HUB HE... | 6" | COUPLING-N.H. HEAVY DUTY | 1 | 42.80 | 42.80 | 0.10 | 0.10 |
| 50350001 | C.I. SOIL NO HUB HE... | 2" | SHORT SWEEP 1/4 BEND | 1 | 22.90 | 22.90 | 0.42 | 0.42 |
| 50400003 | C.I. SOIL NO HUB HE... | 4" x2" | REDUCED COMBINATION | 1 | 39.10 | 39.10 | 0.92 | 0.92 |
| 50430009 | C.I. SOIL NO HUB HE... | 6" x4" | REDUCER-SHORT | 1 | 48.20 | 48.20 | 0.88 | 0.88 |
| 50460001 | C.I. SOIL NO HUB HE... | 2" | TEST TEE-LESS PLUG | 1 | 20.50 | 20.50 | 0.40 | 0.40 |
| Subtotals for Category : Category 050: C.I. SOIL NO HUB HEAVY DUTY | | | | | | 864.90 | | 10.21 |
| Category : Category 057: PLUMBING EQUIPMENT | | | | | | | | |
| 57040004 | PLUMBING EQUIPM... | 5" | CLEANOUT PLUGS/COVRS | 1 | 50.00 | 50.00 | 0.60 | 0.60 |
| Subtotals for Category : Category 057: PLUMBING EQUIPMENT | | | | | | 50.00 | | 0.60 |
| Subtotals for Section : Section 045: COR#27 - BULL#35 HUB DRAINS/PIPING B3 | | | | | | 2,281.78 | | 15.34 |
| Grand Totals | | | | | | 2,281.78 | | 15.34 |

JOB 994 562COR: 562 - LEMONWO...
 ESTIMATE 1 562COR: LEMONWOOD K...
 DATA SET 2 MECH DATABASE 12-31-16

COR#27, BUILDING 4 COST
 CITY COMMERCIAL PLUMBING
 16106 COHASSET ST.
 VAN NUYS, CA 91406
 818-785-1145 / (Company Fax)
 CSNYDER@CCPINC.NET

PRINTED 1/9/2017 5:02:17 PM
 MATERIAL Primary
 LABOR Alternate

NOTES

| Item | | | | Material | | Field Labor | | |
|--------|----------|------|-----------|----------|----------|-------------|----------|---------|
| Item # | Category | Size | Item Desc | Qty | Mat Unit | Mat Ext | Fld Unit | Fld Ext |

Section : Section 046: COR#27 - BULL#35 HUB DRAINS/PIPIG B4 CO

Category : Category 002: PVC SCH 40--DWV

| | | | | | | | | |
|---------|-----------------|--------|----------------------|---|-------|-------|------|------|
| 2020003 | PVC SCH 40--DWV | 3" | P-TRAP--HxH | 1 | 47.18 | 47.18 | 0.50 | 0.50 |
| 2060004 | PVC SCH 40--DWV | 3" | 1/4 BEND -- HxH | 1 | 14.23 | 14.23 | 0.57 | 0.57 |
| 2100004 | PVC SCH 40--DWV | 4" | COMBINATION -- HxHxH | 1 | 36.30 | 36.30 | 1.22 | 1.22 |
| 2290001 | PVC SCH 40--DWV | Unsize | CEMENT--PVC--QTS. | 1 | 30.65 | 30.65 | Skip | 0.00 |
| 2300001 | PVC SCH 40--DWV | Unsize | PRIMER--PVC--QTS. | 1 | 35.65 | 35.65 | Skip | 0.00 |
| 2360002 | PVC SCH 40--DWV | 2" | L.S. 1/4 BEND - HxH | 1 | 8.88 | 8.88 | 0.27 | 0.27 |
| 2360004 | PVC SCH 40--DWV | 4" | L.S. 1/4 BEND - HxH | 2 | 27.36 | 54.72 | 0.81 | 1.62 |
| 2400003 | PVC SCH 40--DWV | 3" x2" | RED COMBO -- HxHxH | 2 | 14.88 | 29.76 | 0.49 | 0.98 |
| 2400004 | PVC SCH 40--DWV | 4" x2" | RED COMBO -- HxHxH | 1 | 26.04 | 26.04 | 0.99 | 0.99 |
| 2400005 | PVC SCH 40--DWV | 4" x3" | RED COMBO -- HxHxH | 1 | 30.24 | 30.24 | 1.06 | 1.06 |
| 2420005 | PVC SCH 40--DWV | 4" x2" | RED SAN TEE -- HxHxH | 1 | 23.56 | 23.56 | 0.99 | 0.99 |
| 2530002 | PVC SCH 40--DWV | 2" | 1/16 BEND -- HxH | 1 | 6.27 | 6.27 | 0.26 | 0.26 |

Subtotals for Category : Category 002: PVC SCH 40--DWV

343.48 8.46

Category : Category 009: SCH 40 PVC

| | | | | | | | | |
|---------|------------|----|----------------|----|------|--------|------|------|
| 9010008 | SCH 40 PVC | 3" | SCH40 PVC PIPE | 20 | 5.82 | 116.40 | 0.08 | 1.60 |
| 9010009 | SCH 40 PVC | 4" | SCH40 PVC PIPE | 20 | 8.28 | 165.60 | 0.10 | 2.00 |

Subtotals for Category : Category 009: SCH 40 PVC

282.00 3.60

Category : Category 049: HANGER-R.CLAMP-ETC.

| | | | | | | | | |
|----------|--------------------|--------|--------------------------|----|------|-------|------|------|
| 102 | HANGER-R.CLAMP-... | | SAMMY ANCHORS WSG 25-380 | 6 | 1.40 | 8.40 | 0.40 | 2.40 |
| 49010006 | HANGER-R.CLAMP-... | 2" | CLEVIS HGR.-BLK. | 6 | 2.10 | 12.60 | 0.50 | 3.00 |
| 49090001 | HANGER-R.CLAMP-... | 7/8" | STRUT CHANNEL | 2 | 2.68 | 5.36 | 0.12 | 0.24 |
| 49090002 | HANGER-R.CLAMP-... | 1-5/8" | STRUT CHANNEL | 2 | 3.16 | 6.32 | 0.12 | 0.24 |
| 49150013 | HANGER-R.CLAMP-... | 2-5/8" | STRUT CLAMP | 2 | 2.83 | 5.66 | 0.10 | 0.20 |
| 49150019 | HANGER-R.CLAMP-... | 6" | STRUT CLAMP | 1 | 7.03 | 7.03 | 0.20 | 0.20 |
| 49150024 | HANGER-R.CLAMP-... | 4-3/8" | STRUT CLAMP | 1 | 4.58 | 4.58 | 0.15 | 0.15 |
| 49380002 | HANGER-R.CLAMP-... | 3/8" | ALL THREAD ROD | 20 | 1.08 | 21.60 | Skip | 0.00 |
| 49390002 | HANGER-R.CLAMP-... | 3/8" | ROD COUPLING | 8 | 1.75 | 14.00 | Skip | 0.00 |
| 49400002 | HANGER-R.CLAMP-... | 3/8" | HEX NUTS | 30 | 0.79 | 23.70 | Skip | 0.00 |
| 49410002 | HANGER-R.CLAMP-... | 3/8" | WASHER--FLAT--ROUND | 30 | 0.26 | 7.80 | Skip | 0.00 |
| 49490001 | HANGER-R.CLAMP-... | Unsize | SCREWS | 8 | 0.43 | 3.44 | Skip | 0.00 |

Subtotals for Category : Category 049: HANGER-R.CLAMP-ETC.

120.49 6.43

Category : Category 050: C.I. SOIL NO HUB HEAVY DUTY

| | | | | | | | | |
|----------|------------------------|----|---------------------------|----|-------|--------|------|------|
| 104 | C.I. SOIL NO HUB HE... | | 2" BRASS PLUG RAISED HEAD | 1 | 9.08 | 9.08 | 0.05 | 0.05 |
| 50010002 | C.I. SOIL NO HUB HE... | 2" | PIPE--C.I. NO HUB | 30 | 11.17 | 335.10 | 0.12 | 3.60 |
| 50020004 | C.I. SOIL NO HUB HE... | 4" | P-TRAP | 1 | 93.10 | 93.10 | 0.88 | 0.88 |
| 50050002 | C.I. SOIL NO HUB HE... | 2" | 1/8 BEND | 1 | 14.20 | 14.20 | 0.38 | 0.38 |
| 50060002 | C.I. SOIL NO HUB HE... | 2" | 1/4 BEND | 2 | 16.50 | 33.00 | 0.39 | 0.78 |
| 50120002 | C.I. SOIL NO HUB HE... | 2" | SANITARY TEE | 1 | 22.70 | 22.70 | 0.56 | 0.56 |
| 50120004 | C.I. SOIL NO HUB HE... | 4" | SANITARY TEE | 1 | 53.00 | 53.00 | 1.11 | 1.11 |

JOB 994 562COR: 562 - LEMONWO...
ESTIMATE 1 562COR: LEMONWOOD K...
DATA SET 2 MECH DATABASE 12-31-16

COR#27, BUILDING 4 COST
CITY COMMERCIAL PLUMBING
16106 COHASSET ST.
VAN NUYS, CA 91406
818-785-1145 / (Company Fax)
CSNYDER@CCPINC.NET

PRINTED 1/9/2017 5:02:17 PM
MATERIAL Primary
LABOR Alternate

NOTES

| Item | | | | Material | | Field Labor | | |
|--|------------------------|--------|--------------------------|----------|----------|-----------------|----------|--------------|
| Item # | Category | Size | Item Desc | Qty | Mat Unit | Mat Ext | Fld Unit | Fld Ext |
| 50280006 | C.I. SOIL NO HUB HE... | 6" | COUPLING-N.H. HEAVY DUTY | 1 | 42.80 | 42.80 | 0.10 | 0.10 |
| 50430003 | C.I. SOIL NO HUB HE... | 4" x2" | REDUCER--SHORT | 1 | 17.90 | 17.90 | 0.54 | 0.54 |
| 50430009 | C.I. SOIL NO HUB HE... | 6" x4" | REDUCER--SHORT | 1 | 48.20 | 48.20 | 0.88 | 0.88 |
| 50460003 | C.I. SOIL NO HUB HE... | 4" | TEST TEE--LESS PLUG | 1 | 59.20 | 59.20 | 0.82 | 0.82 |
| Subtotals for Category : Category 050: C.I. SOIL NO HUB HEAVY DUTY | | | | | | 1,211.68 | | 12.35 |
| Subtotals for Section : Section 046: COR#27 - BULL#35 HUB DRAINS/PIPIG B4 CO | | | | | | 1,957.65 | | 30.84 |
| Grand Totals | | | | | | 1,957.65 | | 30.84 |



December 21, 2016

Oxnard School District
1051 South A Street
Oxnard, CA, 93030

Attn: Ms. Marlene Hickle, CFW Inc.

Subject: Swinerton Builders Job 16055106 - Lemonwood K-8 School LLB
PCI No. 0092 Add HHGU7x24 Simpson Hanger

*2/1/17
M.A.
Approved.
O.C.A.
Contingency*

Dear Ms. Hickle,

We request a Change Order to our contract for the following:

As requested, add beam hanger to accommodate beam configuration.

| Phase | Category | Description | Subcontractor | Quote |
|--------|----------|--|------------------------------|---------------|
| 061000 | 71140 | As requested, add beam hanger to accommodate beam configuration. | ABDELLATIF ENTERPRISES, INC. | 409.73 |
| | | | Subtotal | 409.73 |
| 007480 | 71160 | Subguard | 1.15% | 4.71 |
| 007410 | 71160 | Builders Risk | 0.6% | 2.49 |
| 007420 | 71160 | General Insurance | 1.15% | 4.77 |
| 007510 | 71160 | P&P Bond | 1% | 4.10 |
| 991000 | 79999 | Change Order Fee | 15% | 63.26 |
| | | | Markup Subtotal | 79.33 |
| | | | PCI Total | 489.06 |

Question mark up.

cr.

TOTAL AMOUNT OF THIS CHANGE ORDER REQUEST: **489.06.**

Please NOTE:

- » The incorporation of this revision in to the contractual scope of work may have an impact on our schedule, which is yet to be finalized. Once determined, the job schedule will be adjusted accordingly to show the effect of this revision on the final project completion date..
- » The terms (cost and schedule impact) of this change order request are subject to review and a requote if not accepted within days of its issuance.
- » This request does not include additional cost or delay due to late approval.

X We **HAVE** proceeded with this revised work per your instructions. Please issue a change order.

2/1/17 M.A. TB 2/7/17



Upon acceptance of this change order request, a formal change order will be issued. Acceptance also acknowledges that Swinerton Builders has proceeded with the above change in scope.

If you have any questions or comments pertaining to this matter, please contact the undersigned.

Sincerely,
Swinerton Builders

Bill Gray

PM

Date: _____

12/21/2016

Quotation accepted by:
Oxnard School District

By: _____

Date: _____



2200 Carnegie Court,
Oxnard, CA, 93033

Lemonwood K-8 School LLB
16055106

Request For Information # 00165

| | | | |
|------------|----------------------|-----------------------|------------|
| To: | SVA ARCHITECTS, INC. | RFI Date: | 12/05/2016 |
| Attention: | Tom Bardwell | Date Due: | 11/15/2016 |
| CC: | Paul Vernier | RFI Type: | Structural |
| | Dick Jones | Priority: | Critical |
| | David Chieng | Schedule/Activity ID: | |
| | Peter Sarkis | Document Reference: | |
| | | Spec Section: | 61000 |
| | | Status: | Returned |

Subject: Grid C 6x14 beam elevation

INFORMATION REQUESTED:

Requested By: Nalani Scanlon

1. On S-112A there is a 6x14 along C line between grids 5 and 6. Please specify if this beam is high, top of beam flush to top of joist, or if it is a drop beam.

SUGGESTION:

Possible Cost Impact: Potentially

Possible Time Impact: Potentially

ANSWER:

Answered By: Tom Bardwell

Date of Response: 12/05/2016

Structurally acceptable to have 6x14 flush with top of joists. Joist sub contractor to verify that an adequate connection can be accommodating for the 7x24 redlam per Redbull's calcs in RFI0047.

ATTACHMENTS:



Change Order # 9

DATE: December 9, 2016

PROJECT: Lemonwood K-8 School LLB

Cost proposal associated with RFI 165

Description: Add hanger per RFI 165

| Description | Qty | Unit | Unit Price | Extension |
|---------------------------|-----|------|------------|------------------|
| HHGU7x24 | 1 | | | \$ 209.00 |
| | | | | |
| | | | | |
| | | | | |
| | | | | |
| | | | | |
| Material Subtotal | | | | \$ 209.00 |
| Material Sales Tax | | | | \$ 18.81 |
| Material Total | | | | \$ 227.81 |
| Labor | 2 | | \$ 64.24 | \$ 128.48 |
| Subtotal | | | | \$ 356.29 |
| Profit & Overhead | 15% | | | \$ 53.44 |
| Total Change Order | | | | \$ 409.73 |



January 19, 2017

Oxnard School District
1051 South A Street
Oxnard, CA, 93030

Attn: Ms. Marlene Hickle, CFW Inc.

Subject: Swinerton Builders Job 16055106 - Lemonwood K-8 School LLB
PCI No. 0093 CCD 006

2/7/17
OCA
CCD #6
MH

Dear Ms. Hickle,

We request a Change Order to our contract for the following:

Modify HVAC units and related duct work and structural roof framing

| Phase | Category | Description | Subcontractor | Quote |
|--------|----------|---|--------------------------------|------------------|
| 230010 | 71140 | Modify HVAC units and related duct work and structural roof framing | SHELDON MECHANICAL CORPORATION | 30,648.00 |
| | | | Subtotal | 30,648.00 |
| 007480 | 71160 | Subguard | 1.15% | 352.45 |
| 007410 | 71160 | Builders Risk | 0.6% | 186.00 |
| 007420 | 71160 | General Insurance | 1.15% | 356.51 |
| 007510 | 71160 | P&P Bond | 1% | 306.48 |
| 991000 | 79999 | Change Order Fee | 5% | 1,577.15 |
| | | | Markup Subtotal | 2,778.59 |
| | | | PCI Total | 33,426.59 |

TOTAL AMOUNT OF THIS CHANGE ORDER REQUEST: **33,426.59.**

Please NOTE:

- » The incorporation of this revision in to the contractual scope of work may have an impact on our schedule and cost, which is yet to be finalized. Once determined, the job schedule and cost will be adjusted accordingly to show the effect of this revision on the final project completion date.
- » The terms (cost and schedule impact) of this change order request are subject to review and a requote if not accepted within 5 days of its issuance.
- » This request does not include additional cost or delay due to late approval.

MH 2/7/14 TB 2/11/17



X We **HAVE NOT** proceeded with this revised work per your instructions. Please issue a change order.

Upon acceptance of this change order request, a formal change order will be issued. Acceptance also acknowledges that Swinerton Builders is directed to proceed with the above change in scope.

If you have any questions or comments pertaining to this matter, please contact the undersigned.

Sincerely,
Swinerton Builders

Quotation accepted by:
Oxnard School District

Bill Gray
PM
Date: _____

By: _____
Date: _____

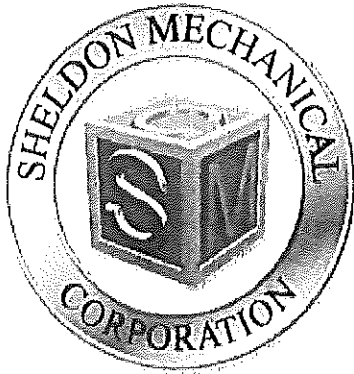

SHELDON MECHANICAL CORPORATION

December 22, 2016

Swinerton
865 S. Figueroa Suite 3000
Los Angeles, Ca. 90017

Attn: Mr. Bill Gray

Subject: Lemonwood K-8 School
SMC COR #6 CCD #16

Dear Bill,

Attached is our itemized credit for Addendum #1 and additional costs associated with CCD #16.

Addendum 1 Credit

- DFI Invoice – Ductwork for Presentation/Serving 2-102.
- Downsizing Ductwork serving Storytelling 3-124 from 34"x16" to 18"x6".

CCD #16 Add

- DFI Invoice – Revised Duct Layout for Presentation/Serving 2-102, 2" Lined Rooftop Ductwork serving AC3-2, (1) Hot Dipped Galvanized Power Exhaust Stand, (8) Duct Stands and (2) Flashings.
- Layout for (1) Power Exhaust Stand and (8) Duct Stands.
- Install (1) Power Exhaust Stand and (8) Duct Stands.
- Rigging Hours for Rooftop Ductwork (1) Power Exhaust Stand, (8) Duct Stands and (2) Flashings.
- Additional Supervision.
- Additional Shop Drawing Time and Coordination for Revising the Duct Layout for Presentation/Serving 2-102 and Rooftop Ductwork being served by AC3-2, as well as the clouded changes in Building 3.
- Additional Detailing for the Rooftop Ductwork and Stands.
- Additional Cleanup and Material Handling.
- Freight cost to Deliver Rooftop Ductwork and Stands.
- 1 Day Rental for Reach Forklift.

This Work Excludes Furnishing or Wiring of Smoke Detectors.

Cost for SMC COR #6 is \$30,648.00

SHELDON MECHANICAL CORPORATION

26015 Avenue Hall, Santa Clarita, CA 91355 Office: (661) 286-1361 Fax: (661) 287-9083
California State Contractors License Number 463722 – C20. C38

If you have any questions please call me.

Sincerely,

Dillon J. Boute

Dillon J. Boute

SHELDON MECHANICAL CORPORATION

26015 Avenue Hall, Santa Clarita, CA 91355 Office: (661) 286-1361 Fax: (661) 287-9083
California State Contractors License Number 463722 - C20. C38

| | |
|------|----------------------|
| Data | Sheldon 3/19/04 |
| Job | Lemonwood K-8 School |
| Bid | SMC COR #6 Credit |

Sheldon Mechanical Corporation
26015 avenue hall
Santa Clarita, CA 91355

| | |
|----------|------|
| DATE | PAGE |
| 12/18/16 | 1 |
| TIME | |
| 01:09 PM | |

Phone: 661-286-1361

FAX: 661-287-9081

| | Description | Ref | Ref Amount | Op | Rate | Amount |
|----|---------------------|---------|------------|----|-------|-----------|
| 1 | MATERIAL: | | | | | |
| 2 | DFI Invoice | | | | | 4,350.00 |
| 3 | SUBTOTAL | | | | | 4,350.00 |
| 4 | | | | | | |
| 5 | MAJOR QUOTATIONS: | | | | | |
| 6 | EQUIPMENT: | | | | | |
| 7 | | | | | | |
| 8 | AIR DISTRIBUTION: | | | | | |
| 9 | NSW | | | | | 145.00 |
| 10 | Delete (3) 34x16 | | | | | |
| 11 | Add (3) 18x6 | | | | | |
| 12 | SUBTOTAL | | | | | 145.00 |
| 13 | | | | | | |
| 14 | SALES TAX | | | | | |
| 15 | Material Total | Line 3 | 4,350.00 | % | 9.00 | 391.50 |
| 16 | Major Quotations | Line 12 | 145.00 | % | 8.00 | 11.60 |
| 17 | SUBTOTAL | | | | | 403.10 |
| 18 | | | | | | |
| 19 | DIRECT FIELD LABOR: | | | | | |
| 20 | Ductwork | Calc | 45.05 | * | 96.86 | 4,363.09 |
| 21 | SUBTOTAL | | | | | 4,363.09 |
| 22 | | | | | | |
| 23 | SUB CONTRACTS: | | | | | |
| 24 | INSULATION: | | | | | |
| 25 | P&E | | | | | 7,313.00 |
| 26 | SUBTOTAL | | | | | 7,313.00 |
| 27 | | | | | | |
| 28 | JOB SUBTOTAL | | | | | 16,574.19 |
| 29 | | | | | | |
| 30 | JOB TOTAL | | | | | 16,574.19 |

CF.

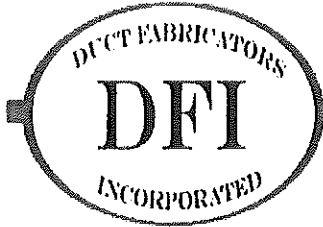

P.O. Box 803338, Santa Clarita, CA 91380

Tel: 661-705-8780 Fax: 661-705-8790

December 21, 2016

TO: Lemonwood K-8 School

BILL TO: Mr. Dillon Boute'
Sheldon Mechanical Corp
26015 Avenue Hall
Santa Clarita, CA 91355
661-286-1361

DESCRIPTION

AMOUNT

Please reference your sheets tagged: Addendum 1 Mechanical Drawings
All material constructed per your details and specifications
Ductwork associated with Presentation/Serving 2-102 - Building 2
Ductwork Resized from 34"x16" to 18"x6" Story Telling 3-124 - Building 3

\$ 4,350.00

| | | |
|------------|----|----------|
| AMOUNT | \$ | 4,350.00 |
| DISCOUNT | | 9.00% |
| NET AMOUNT | | 391.50 |
| TOTAL | \$ | 4,741.50 |

Make all checks payable to Duct Fabricators Incorporated.
THANK YOU FOR YOUR BUSINESS!



NORMAN S. WRIGHT
CLIMATEC
MECHANICAL EQUIPMENT

2544 E. Miraloma Way, Anaheim, CA 92806-1608
13031 Bradley Avenue Sylmar, CA 91342-3832

tel 714.632.9800 fax 714.632.6900
tel 818.367.6100 fax 818.367.1221

Air Handlers-Air Distribution-Air Doors-Gas Chillers-Dampers/Louvers-Energy Recovery-Fan Cooling-Fans/Ventilators-Fan Coils-Gas/Smoke Detection Humidification-Infra-red Heaters-Lab Control
Valves-Kitchen Ventilation-Heating and Make-up Air-Sound Attenuation-Underfloor Air Distribution-VFD-Vehicle Exhaust-Water Source Heat Pumps

Equipment Proposal

Quote # 91541 CCD-16

To: Sheldon Mechanical Corporation

Job: Lemonwood K-8 Reconstruction

Att: Dillon Boute

Loc: Oxnard, CA

By: Mike Kline

Eng: OED

Bid Date: 12-21-2016

Plan Date: 10-17-2016 CCD-16

NORMAN S WRIGHT CLIMATEC MECHANICAL EQUIPMENT OF SOUTHERN CALIFORNIA IS PLEASED TO
OFFER THE FOLLOWING FOR YOUR CONSIDERATION

Drawing M3-11.1

Price industries Air Distribution

Delete the following:

- 3 Model LBP aluminum construction, linear bar grille, no plenums included (SD-7) Size 34 x 16

**DEDUCT
<\$145.00>
Cost Impact**

Add the following:

- 3 Model LBP aluminum construction, linear bar grille, no plenums included (SD-7) Size 18 x 6



F.O.B. factory / FFA

Due to recent volatility in raw material prices, unless quote is accepted within 30 days, and released for shipment within 90 days, prices are subject to change.

All quotations based on best available information and subject to the following:

Consignee is responsible for all freight claims. All prior to delivery calls are subject to a surcharge by the freight carrier. All orders entered by NSWC So Cal subject to cancellation charges. All agreements are subject to strikes, accidents, or other causes beyond our control. All quotations subject to corrections of clerical or math errors. Acceptance of each order is subject to approval of NSW So Cal credit department, and customer acceptance of NSWC SO Cal terms of payment. Payment for partial shipment is due on the basis of invoice dates covering them. Every order is subject to any Federal, State, County, or Local Excise sales or use taxes. Quotations are for prompt acceptance only, and prices are subject to change without notice.

HVAC SUBTOTAL REPORT

Sheldon 3/19/04

Thu Dec 15 12:12:06 2016

Job: 12/8/15 Lemonwood K-6 School
 ZONE # M2-11.1 Bldg 2 Room 2-102 Addendum 1
 Print Subtotals

PAGE : 1

| Num | Description | Field Labor Subtotal |
|-------|---------------------------|-------------------------|
| 1 | GALVANIZED | 11.54 |
| 11 | ENGINEERING/DRAWING LABOR | 2.36 |
| 13 | 1"-1.5# Liner | 1.19 |
| 22 | S.M. ACCESSORIES | 0.00 |
| 23 | HANGER | 3.07 |
| 24 | FLEX CONNECTOR | 2.62 |
| 25 | JOINTS | 2.20 |
| 26 | SEALANTS | 2.65 |
| 33 | 26 GA. GALV SPIRAL PIPE | 1.20 |
| 34 | 24 GA. GALV SPIRAL PIPE | 2.64 |
| 74 | 26 GA. GALV. FITTINGS | 1.25 |
| 75 | 24 GA. GALV. FITTINGS | 1.83 |
| 121 | SPIN COLLARS | 3.00 |
| 397 | HANGERS | 1.06 |
| Total | | 34.25 |

HVAC SUBTOTAL REPORT

Sheldon 3/19/04

Thu Dec 15 12:13:07 2016

Job: 12/8/15 Lemonwood K-8 School
ZONE # M3-11.1 Bldg 3 Addendum 1
Print Subtotals

PAGE : 1

| Num | Description | Field Labor Subtotal |
|-------|---------------------------|-------------------------|
| 1 | GALVANIZED | 6.46 |
| 11 | ENGINEERING/DRAWING LABOR | 1.15 |
| 13 | 1"-1.5# Liner | 0.56 |
| 22 | S.M. ACCESSORIES | 0.00 |
| 23 | HANGER | 1.37 |
| 25 | JOINTS | 1.03 |
| 26 | SEALANTS | 1.38 |
| Total | | 10.85 |



5971 Lakeshore Dr. • Cypress, CA 90630 • Tel: 714.527.5071 • Fax: 714.527.5169

December 21, 2016

Customer: Sheldon

Attention: Dillon Boute

Project: Lemonwood K 8 School

Subject: CCD#16 Credit

Scope: Delete sound lagging on ductwork MPR.
Delete duct wrap on concealed unlined ducts AC-3 (revised duct is all internally lined)

| | |
|------------------|------------|
| Credit Materials | \$4,253.00 |
| Credit Labor | \$3,060.00 |

Respectfully Submitted,

Gordon Ryan

◆ Contractor's License No. 763803 ◆
◆ Contractor's DIR No. 1000001774 ◆

| | |
|------|----------------------|
| Date | Sheldon 3/19/04 |
| Job | Lemonwood K-8 School |
| Bid | SMC COR #6 Add |

Sheldon Mechanical Corporation
26015 avenue hall
Santa Clarita, CA 91355

| | |
|----------|------|
| DATE | PAGE |
| 12/18/16 | 1 |
| TIME | |
| 09:55 AM | |

Phone 661-286-1361

FAX: 661-287-9081

| Description | Ref | Ref Amount | Op | Rate | Amount |
|-------------------------|---------|------------|----|--------|-----------|
| 1 MATERIAL: | | | | | |
| 2 DFI Invoice | | | | | 17,345.00 |
| 3 SUBTOTAL | | | | | 17,345.00 |
| 4 | | | | | |
| 5 MAJOR QUOTATIONS: | | | | | |
| 6 EQUIPMENT: | | | | | |
| 7 | | | | | |
| 8 AIR DISTRIBUTION: | | | | | |
| 9 NSW | | | | | 3,865.00 |
| 10 4 Diffusers | | | | | |
| 11 SUBTOTAL | | | | | 3,865.00 |
| 12 | | | | | |
| 13 SALES TAX: | | | | | |
| 14 Material Total | Line 3 | 17,345.00 | % | 9.00 | 1,561.05 |
| 15 Major Quotations | Line 11 | 3,865.00 | % | 8.00 | 309.20 |
| 16 SUBTOTAL | | | | | 1,870.25 |
| 17 | | | | | |
| 18 DIRECT FIELD LABOR: | | | | | |
| 19 Ductwork | Calc | 95.00 | * | 96.85 | 9,200.75 |
| 20 Layout | Calc | 4.00 | * | 116.10 | 464.40 |
| 21 Install 3 Diffusers | Calc | 6.00 | * | 96.95 | 581.70 |
| 22 Install 8 Stands | Calc | 24.00 | * | 96.85 | 2,324.40 |
| 23 Install 1 P/Exhaust | Calc | 1.00 | * | 96.85 | 96.85 |
| 24 Install 2 Flashings | Calc | 2.00 | * | 96.85 | 193.70 |
| 25 Rigging | Calc | 6.00 | * | 96.85 | 581.10 |
| 26 SUBTOTAL | | | | | 13,442.90 |
| 27 | | | | | |
| 28 NON-PROD LABOR HRS: | | | | | |
| 29 Supervision Hours | Calc | 1.00 | * | 116.10 | 116.10 |
| 30 Shop Drawings | Calc | 16.00 | * | 106.10 | 1,697.60 |
| 31 Detailing | Calc | 4.00 | * | 116.10 | 464.40 |
| 32 Cleanup | Calc | 2.00 | * | 96.85 | 193.70 |
| 33 SUBTOTAL | | | | | 2,471.80 |
| 34 | | | | | |
| 35 DIRECT JOB EXPENSES: | | | | | |
| 36 Reach Forklift | | | | | 600.00 |
| 37 Freight | Calc | 4.00 | * | 75.00 | 300.00 |
| 38 Material Handling | Calc | 4.00 | * | 96.85 | 387.40 |
| 39 SUBTOTAL | | | | | 1,287.40 |
| 40 | | | | | |
| 41 SUB CONTRACTS | | | | | |
| 42 INSULATION: | | | | | |
| 43 P&E | | | | | 780.00 |
| 44 SUBTOTAL | | | | | 780.00 |
| 45 | | | | | |
| 46 JOB SUBTOTAL | | | | | 41,062.35 |
| 47 | | | | | |
| 48 OVERHEAD MARKUP: | | | | | |
| 49 Flat Rate Markup | Line 46 | 41,062.35 | % | 15.00 | 6,159.35 |
| 50 Material | Line 3 | 17,345.00 | % | | |
| 51 Major Quotations | Line 11 | 3,865.00 | % | | |
| 52 Sales Tax | Line 16 | 1,870.25 | % | | |
| 53 Direct Field Labor | Line 26 | 13,442.90 | % | | |

| | |
|------|----------------------|
| Data | Sheldon 3/19/04 |
| Job | Lemonwood K-8 School |
| Bid | SMC COR #6 Add |

Sheldon Mechanical Corporation
 26015 avenue hall
 Santa Clarita, CA 91355

| | |
|----------|------|
| DATE | PAGE |
| 12/18/16 | 2 |
| TIME | |
| 09:55 AM | |

Phone: 661-286-1361

FAX: 661-287-9081

| Description | Ref | Ref Amount | Op | Rate | Amount |
|------------------------|---------|------------|----|------|-----------|
| 54 Direct Shop Labor | Line 27 | 0.00 | % | | |
| 55 Specialized Labor | Line 27 | 0.00 | % | | |
| 56 Indirect Labor | Line 27 | 0.00 | % | | |
| 57 Non-Productive Lbr. | Line 33 | 2,471.80 | % | | |
| 58 Direct Job Expenses | Line 39 | 1,287.40 | % | | |
| 59 Sub Contracts | Line 40 | 0.00 | % | | |
| 60 JOB TOTAL | | | | | 47,221.70 |

ex.



P.O. Box 803338, Santa Clarita, CA 91380

Tel: 661-705-8780 Fax: 661-705-8790

December 21, 2016

FOR: Lemonwood K-8 School

BILL TO: Mr. Dillon Boute'
Sheldon Mechanical Corp
26015 Avenue Hall
Santa Clarita, CA 91355
661-286-1361

DESCRIPTION

AMOUNT

| | |
|--|--------------|
| Please reference your sheets tagged: CCD #16 | \$ 17,345.00 |
| All material constructed per your details and specifications | |
| Ductwork associated with Presentation/Serving 2-102 - Building 2 | |
| 2" Lined Rooftop Ductwork serving AC3-2 - Building 2 Roof | |
| (1) Hot Dipped Galvanized Power Exhaust Stand - Building 2 Roof | |
| (8) Duct Stands - Building 2 Roof | |
| (2) Flashings - Building 2 Roof | |

| | |
|--------------|---------------------|
| Subtotal | \$ 17,345.00 |
| Discount | 9.00% |
| Net Total | 1,561.05 |
| TOTAL | \$ 18,906.05 |

Make all checks payable to Duct Fabricators Incorporated.
THANK YOU FOR YOUR BUSINESS!



NORMAN S. WRIGHT
CLIMATEC
MECHANICAL EQUIPMENT

2544 E. Miraloma Way, Anaheim, CA 92806-1608
13031 Bradley Avenue Sylmar, CA 91342-3832

tel 714.632.9800 fax 714.632.6900
tel 818.367.6100 fax 818.367.1221

Air Handlers-Air Distribution-Air Doors-Gas Chillers-Dampers/Louvers-Energy Recovery-Exap Cooling-Fans/Ventilators-Fan Coils-Gas/Smoke Detection Humidification-Infra-red Heaters-Lab Control
Valves-Kitchen Ventilation-Heating and Make-up Air-Sound Attenuation-Underfloor Air Distribution-VFD-Vehicle Exhaust-Water Source Heat Pumps

Equipment Proposal

Quote # 91541 CCD-16

To: Sheldon Mechanical Corporation
Att: Dillon Boute
By: Mike Kline

Job: Lemonwood K-B Reconstruction
Loc: Oxnard, CA
Eng: OED
Bld Date: 12-21-2016
Plan Date: 10-17-2016 CCD-16

NORMAN S WRIGHT CLIMATEC MECHANICAL EQUIPMENT OF SOUTHERN CALIFORNIA IS PLEASED TO OFFER THE FOLLOWING FOR YOUR CONSIDERATION

Drawing M2-11.2
Price industries Air Distribution

Delete the following:

- 4 Model SMCD steel construction, square neck, modular core diffuser, T-bar application, wit round neck adaptor. (SD-2) 500 CFM
- 2 Model 530 steel construction, square neck, louvered return grille, T-bar application, with round neck adaptor. (RG-2) 650 CFM

ADD
\$195.00
Cost Impact

Add the following:

- 8 Model SMCD steel construction, square neck, modular core diffuser, T-bar application, wit round neck adaptor. (SD-2) 250 CFM
- 2 Model 530 steel construction, square neck, louvered return grille, T-bar application, with round neck adaptor. (RG-2) 1,000 CFM



F.O.B. factory / FFA

Due to recent volatility in raw material prices, unless quote is accepted within 30 days, and released for shipment within 90 days, prices are subject to change.

All quotations based on best available information and subject to the following:

Consignee is responsible for all freight claims. All prior to delivery calls are subject to a surcharge by the freight carrier. All orders entered by NSWC So Cal subject to cancellation charges. All agreements are subject to strikes, accidents, or other causes beyond our control. All quotations subject to corrections of clerical or math errors. Acceptance of each order is subject to approval of NSW So Cal credit department, and customer acceptance of NSWC SO Cal terms of payment. Payment for partial shipment is due on the basis of invoice dates covering them. Every order is subject to any Federal, State, County, or Local Excise sales or use taxes. Quotations are for prompt acceptance only, and prices are subject to change without notice.

HVAC SUBTOTAL REPORT

Sheldon 3/19/04

Thu Dec 15 12:12:29 2016

Job: 12/8/15 Lemonwood K-8 School
ZONE # H2-11.1 Bldg 2 Room 2-102 CCD #16
Print Subtotals

PAGE : 1

| Num | Description | Field Labor Subtotal |
|-------|---------------------------|-------------------------|
| 1 | GALVANIZED | 26.84 |
| 11 | ENGINEERING/DRAWING LABOR | 5.57 |
| 13 | 1"-1.5" Liner | 2.34 |
| 22 | S.M. ACCESSORIES | 0.00 |
| 23 | HANGER | 6.21 |
| 25 | JOINTS | 4.93 |
| 26 | SEALANTS | 5.85 |
| 33 | 26 GA. GALV SPIRAL PIPE | 2.10 |
| 74 | 26 GA. GALV. FITTINGS | 3.16 |
| 120 | FLEX DUCT | 3.34 |
| 397 | HANGERS | 1.80 |
| Total | | 56.57 |

HVAC SUBTOTAL REPORT

Sheldon 3/19/04

Thu Dec 15 12:12:45 2016

Job: 12/8/15 Lemonwood K-8 School
ZONE # M2-11.2 Bldg 2 Unit AC3-2 CCD #16
Print Subtotals

PAGE : 1

| Num | Description | Field Labor Subtotal |
|-------|---------------------------|-------------------------|
| 1 | GALVANIZED | 17.93 |
| 11 | ENGINEERING/DRAWING LABOR | 4.62 |
| 18 | 2"- 1.5#Liner | 0.54 |
| 22 | S.M. ACCESSORIES | 0.00 |
| 23 | HANGER | 3.73 |
| 24 | FLEX CONNECTOR | 2.45 |
| 25 | JOINTS | 3.62 |
| 26 | SEALANTS | 4.50 |
| Total | | 32.77 |

HVAC SUBTOTAL REPORT

Sheldon 3/19/04

Thu Dec 15 12:13:27 2016

Job: 12/9/15 Lerowood K-8 School
ZONE # M3-11.1 Bldg 3 CCD #16
Print Subtotals

PAGE : 1

| Num | Description | Field Labor Subtotal |
|-------|---------------------------|-------------------------|
| 1 | GALVANIZED | 3.09 |
| 11 | ENGINEERING/DRAWING LABOR | 0.51 |
| 22 | S.M. ACCESSORIES | 0.00 |
| 23 | HANGER | 1.05 |
| 25 | JOINTS | 0.15 |
| 26 | SEALANTS | 0.61 |
| 33 | 26 GA. GALV SPIRAL PIPE | 0.20 |
| 74 | 26 GA. GALV. FITTINGS | 0.50 |
| 197 | HANGERS | 0.06 |
| Total | | 5.66 |



5971 Lakeshore Dr. • Cypress, CA 90630 • Tel: 714.527.5071 • Fax: 714.527.5169

December 21, 2016

Customer: Sheldon

Attention: Dillon Boute

Project: Lemonwood K 8

Subject: CCD #16 Add

Our proposal to provide and install thermal insulation is as follows:

Scope:

- Wrap ROUND S & R Ducts indoors off AC-3

Price: \$ 780.00

Respectfully Submitted,

Gordon Ryan

◆ Contractor's License No. 763803 ◆
◆ Contractor's DIR No. 1000001774 ◆



January 27, 2017

Oxnard School District
1051 South A Street
Oxnard, CA, 93030

Attn: Ms. Marlene Hickie, CFW Inc.

Subject: Swinerton Builders Job 16055106 - Lemonwood K-8 School LLB
PCI No. 0123 RFI 185 Add ledger

*2/7/17
Contingency (OCA)
Design Change*

Dear Ms. Hickie,

We request a Change Order to our contract for the following:

At 2nd floor framing the joists are shown to be installed in hangers directly to wall framing without a ledger which could potentially cause the nailing to fall in area that would fail to hold desired load. Add ledger to receive hangers.

| Phase | Category | Description | Subcontractor | Quote |
|--------|----------|---|------------------------------|-----------------|
| 061000 | 71140 | RFI 185 Add 2x12 ledger at 2nd floor corridor framing | ABDELLATIF ENTERPRISES, INC. | 6,887.87 |
| | | | Subtotal | 6,887.87 |
| 007480 | 71160 | Subguard | 1.15% | 79.21 |
| 007410 | 71160 | Builders Risk | 0.6% | 41.80 |
| 007420 | 71160 | General Insurance | 1.15% | 80.12 |
| 007510 | 71160 | P&P Bond | 1% | 68.88 |
| 991000 | 79999 | Change Order Fee | 5% | 354.45 |
| | | | Markup Subtotal | 624.46 |
| | | | PCI Total | 7,512.33 |

cy.

TOTAL AMOUNT OF THIS CHANGE ORDER REQUEST: 7,512.33.

Please NOTE:

- » The incorporation of this revision in to the contractual scope of work may have an impact on our schedule and cost, which is yet to be finalized. Once determined, the job schedule and cost will be adjusted accordingly to show the effect of this revision on the final project completion date.
- » The terms (cost and schedule impact) of this change order request are subject to review and a requote if not accepted within days of its issuance.
- » This request does not include additional cost or delay due to late approval.

We **HAVE NOT** proceeded with this revised work per your instructions. Please issue a change order.

2/7/17 - msh 2/7/17



Upon acceptance of this change order request, a formal change order will be issued. Acceptance also acknowledges that Swinerton Builders is directed to proceed with the above change in scope.

If you have any questions or comments pertaining to this matter, please contact the undersigned.

Sincerely,
Swinerton Builders

Bill Gray
PM
Date: _____

1/27/2017

Quotation accepted by:
Oxnard School District

By: _____

Date: _____



Change Order # 13

DATE: January 26, 2016
 PROJECT: Lemonwood K-8 School LLB

Cost proposal associated with RFI 185

Description: Add 2x12 ledger at corridor with 4 1/2 SDS

| Description | Qty | Unit | Unit Price | Extension |
|---------------------------|------|------|------------|--------------------|
| 2x12 | 420' | | \$ 2.50 | \$ 1,050.00 |
| 1/4 x 4 1/2 SDS | 636 | | \$ 348.60 | \$ 384.60 |
| | | | | |
| | | | | |
| | | | | |
| | | | | |
| Material Subtotal | | | | \$ 1,434.60 |
| Material Sales Tax | | | | \$ 115.01 |
| Material Delivery | | | | \$ 200.00 |
| Material Total | | | | \$ 1,749.61 |
| Labor | 66 | | \$ 64.24 | \$ 4,239.84 |
| Subtotal | | | | \$ 5,989.45 |
| Profit & Overhead | 15% | | | \$ 898.42 |
| Total Change Order | | | | \$ 6,887.87 |

05-



January 27, 2017

Oxnard School District
1051 South A Street
Oxnard, CA, 93030

Attn: Ms. Marlene Hickle, CFW Inc.

Subject: Swinerton Builders Job 16055106 - Lemonwood K-8 School LLB
PCI No. 0124 CCD 017

*2/7/17
Contingency
Design change
MTH*

Dear Ms. Hickle,

We request a Change Order to our contract for the following:

Add wood frame posts and hold downs along gridline D from ground floor to roof as directed in CCD 017

| Phase | Category | Description | Subcontractor | Quote |
|--------|----------|---|------------------------------|-----------------|
| 061000 | 71140 | CCD 017 Add structural posts and hold downs | ABDELLATIF ENTERPRISES, INC. | 5,663.47 |
| | | | Subtotal | 5,663.47 |
| 007480 | 71160 | Subguard | 1.15% | 65.13 |
| 007410 | 71160 | Builders Risk | 0.6% | 34.37 |
| 007420 | 71160 | General Insurance | 1.15% | 65.88 |
| 007510 | 71160 | P&P Bond | 1% | 56.64 |
| 991000 | 79999 | Change Order Fee | 5% | 291.44 |
| | | | Markup Subtotal | 513.46 |
| | | | PCI Total | 6,176.93 |

OK.

TOTAL AMOUNT OF THIS CHANGE ORDER REQUEST: **6,176.93.**

Please NOTE:

- » The incorporation of this revision in to the contractual scope of work may have an impact on our schedule and cost, which is yet to be finalized. Once determined, the job schedule and cost will be adjusted accordingly to show the effect of this revision on the final project completion date.
- » The terms (cost and schedule impact) of this change order request are subject to review and a requote if not accepted within days of its issuance.
- » This request does not include additional cost or delay due to late approval.

We **HAVE NOT** proceeded with this revised work per your instructions. Please issue a change order.

2/7/17 mat TB 2/7/17



Upon acceptance of this change order request, a formal change order will be issued. Acceptance also acknowledges that Swinerton Builders is directed to proceed with the above change in scope.

If you have any questions or comments pertaining to this matter, please contact the undersigned.

Sincerely,
Swinerton Builders

Bill Gray

PM

Date: _____

4/22/2017

Quotation accepted by:
Oxnard School District

By: _____

Date: _____



Change Order #

14

DATE: January 26, 2016

PROJECT: Lemonwood K-8 School LLB

Cost proposal associated with CCD 17

Description: Add posts and holddowns from floor to roof along grid D

| Description | Qty | Unit | Unit Price | Extension |
|--------------------------------------|-----|------|------------|--------------------|
| 6x6x14 DF #1 Dry | 6 | | \$ 49.00 | \$ 294.00 |
| 3x6x14 DF #1 Dry | 3 | | \$ 38.50 | \$ 115.50 |
| 7/8x4' allthread | 4 | | \$ 13.00 | \$ 52.00 |
| 7/8x4' allthread HDG A36 | 2 | | \$ 17.00 | \$ 34.00 |
| HDU8 | 10 | | \$ 32.25 | \$ 322.50 |
| Set-XP Simpson Epoxy | 2 | | \$ 27.54 | \$ 55.08 |
| 7/8" nuts | 10 | | \$ 0.65 | \$ 6.50 |
| 1"x31" roto hammer bit | 1 | | \$ 91.97 | \$ 91.97 |
| | | | | |
| Material Subtotal | | | | \$ 971.55 |
| Material Sales Tax | | | | \$ 91.53 |
| Material Delivery | | | | \$ 200.00 |
| Material Total | | | | \$ 1,263.08 |
| Labor (add 6 new post) | 19 | | \$ 64.24 | \$ 1,220.56 |
| Labor (install 10 HD10s & allthread) | 38 | | \$ 64.24 | \$ 2,441.12 |
| Subtotal | | | | \$ 4,924.76 |
| Profit & Overhead | 15% | | | \$ 738.71 |
| Total Change Order | | | | \$ 5,663.47 |

ex.



*Changed By DSA.
as Part of C.O. 15 5+14
& Bulletin 32
2/7/17
Contingency*

February 6, 2017

Oxnard School District
1051 South A Street
Oxnard, CA, 93030

Attn: Ms. Marlene Hickle, CFW Inc.

Subject: Swinerton Builders Job 16055106 - Lemonwood K-8 School LLB
PCI No. 0141 Add roof framing supports and waterproof roofing penetrations in Classroom Building- Bulletin 32

Dear Ms. Hickle,

We request a Change Order to our contract for the following:

Add roof framing supports and waterproof roofing penetrations in Classroom Building

| Phase | Category | Description | Subcontractor | Quote |
|--------|----------|---|------------------------------|------------------|
| 061000 | 71140 | Add roof framing supports and waterproof roofing penetrations in Classroom Building | ABDELLATIF ENTERPRISES, INC. | 11,818.00 |
| 075400 | 71140 | Add roof framing supports and waterproof roofing penetrations in Classroom Building | LETNER ROOFING COMPANY | 10,679.00 |
| | | | Subtotal | 22,497.00 |
| 007480 | 71160 | Subguard | 1.15% | 258.72 |
| 007410 | 71160 | Builders Risk | 0.6% | 136.53 |
| 007420 | 71160 | General Insurance | 1.15% | 261.69 |
| 007510 | 71160 | P&P Bond | 1% | 224.97 |
| 991000 | 79999 | Change Order Fee | 15% | 3,473.09 |
| | | | Markup Subtotal | 4,355.00 |
| | | | PCI Total | 26,852.00 |

Question Markup.

C.O.

TOTAL AMOUNT OF THIS CHANGE ORDER REQUEST: **26,852.00.**

Please NOTE:

- » The incorporation of this revision in to the contractual scope of work may have an impact on our schedule and cost, which is yet to be finalized. Once determined, the job schedule and cost will be adjusted accordingly to show the effect of this revision on the final project completion date.
- » The terms (cost and schedule impact) of this change order request are subject to review and a requote if not accepted within days of its issuance.
- » This request does not include additional cost or delay due to late approval.

We **HAVE NOT** proceeded with this revised work per your instructions. Please issue a change order.

2/7/17 mgl *2/7/17*

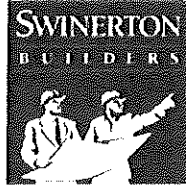

Upon acceptance of this change order request, a formal change order will be issued. Acceptance also acknowledges that Swinerton Builders is directed to proceed with the above change in scope.

If you have any questions or comments pertaining to this matter, please contact the undersigned.

Sincerely,
Swinerton Builders

A handwritten signature in black ink, appearing to read "Bill Gray", is written over the printed name.

Bill Gray

PM

Date: 2/06/2017

Quotation accepted by:
Oxnard School District

By: _____

Date: _____



Lemonwood Change Order 13 Revised

Additional Cost associated with Bulletin 32.

Description: Bulletin 32 requires blocking for the power exhaust support post.

Labor

| | | | | |
|-----------|-------------------------------|------|---------------|-------------|
| 120 hours | Install blocking for 128 post | Rate | \$ 64.24 hour | \$ 7,708.80 |
|-----------|-------------------------------|------|---------------|-------------|

Material

| | | | |
|--------|---------------------|----------|-------------|
| 18 pc | 4x4x16' DF #1 | \$ 24.00 | \$ 432.00 |
| 282 pc | huc44 | \$ 4.87 | \$ 1,373.34 |
| 10 pc | 2x12x16 DF #1 | \$ 26.76 | \$ 267.60 |
| 2 bx | 1 1/2" PP nails | \$ 42.00 | \$ 84.00 |
| 1 | 3 1/4"x3" gun nails | \$ 50.00 | \$ 50.00 |

Material Tax \$ 160.68

Material delivery \$ 200.00

Subtotal \$ 10,276.42

Profit and Overhead 15% \$ 1,541.46

Change order Total \$ 11,818

US.



**CHANGE ORDER
PRICING # 8074-2**

Est. 1957
Lic. No. 689961

1490 N GLASSELL STREET
ORANGE, CA 92867
Phone: 714-633-0030 Fax: 714-633-0280

To: SWINERTON BUILDERS
865 SOUTH FIGUEROA STREET, STE 3000,
LOS ANGELES, CA, 90017
Phone: 213/896-3400 Fax: 213/896-0027

Owner/Arch Reference # 16055106-034
Brief Description Cost for 70 TPO Boots and Labor

JOB: LEMONWOOD K-8 SCHOOL LLB

Change Order Type CHANGE IN CONTRACT SCOPE
Submitted Date 1/27/2017

JOB NO: 8074

Accepted Date
Status PENDING
Approved CO NO

| Item No | Description | Qty/Unit | Unit Cost | Amount |
|---|-------------------------------------|-----------|-----------|------------|
| <i>Provide and install 70 TPO pipe boots on added mechanical pipe support penetrations per CCD's 5 and 16 and bulletin 32</i> | | | | |
| 1 | Firestone TPO - Pipe Boots - Large | 7.00 cart | \$240.00 | \$1,680.00 |
| 2 | Firestone .060 TPO - T-Joint Covers | 2.00 cart | \$150.00 | \$300.00 |
| 3 | Firestone TPO - Cut Edge Sealant | 2.00 cart | \$175.00 | \$350.00 |
| 4 | Foreman Labor | 24.00 hr | \$81.25 | \$1,950.00 |
| 5 | Labor | 64.00 hr | \$74.95 | \$4,797.00 |
| | Tax | | 9.00 % | \$210.00 |
| | C.O. Overhead | | 10.00 % | \$929.00 |
| | C.O. Profit | | 5.00 % | \$464.00 |

| | | |
|---|--------------|--------------------|
| Original Contract Sum | \$ | \$614,900.00 |
| Pending Change Orders | \$ 25,051.00 | |
| Approved Change Orders to Date | \$ | 0.00 |
| Contract Sum prior to this Change Order | \$ | \$614,900.00 |
| Contract Sum increased/(decreased) by this Change Order | \$ | \$10,679.00 |
| Contract Sum including this Change Order | \$ | \$625,579.00 |

Approved by: _____ Submitted by: Joe Suttle
Signature: _____ Date: _____ Signature: _____ Date: 01/27/2017

Regular Board Meeting
January 18, 2017

Minutes not yet approved

The Board of Trustees of the Oxnard School District met in regular session at 5:05 p.m. on Wednesday, January 18, 2017, at the Educational Service Center.

CALL TO ORDER

A roll call of the Board was conducted. Present were President Ernest “Mo” Morrison and Trustees, Debra M. Cordes, Denis O’Leary, Veronica Robles-Solis and Monica Madrigal Lopez. Staff members present were District Superintendent Dr. Cesar Morales, Deputy Superintendent Lisa Cline and Assistant Superintendents Robin Freeman and Dr. Jesus Vaca, and executive assistant Sylvia Carabajal.

ROLL CALL

Giovanny Alcala Mora, 5th grader in Ms. Barraza’s class, student at Marina West Academy of Environmental Science & Creative Arts, lead the audience in the Pledge of Allegiance.

PLEDGE OF ALLEGIANCE

Kyndra Cooksley, 5th grader in Mrs. Vargas’ class, student at Marina West Academy of Environmental Science & Creative Arts, read the District’s Vision and Mission Statements in English and Nancy Torres, 5th grader in Ms. Barraza’s class read them in Spanish.

DISTRICT’S VISION AND MISSION STATEMENTS

Mr. Jorge Mares, Principal at Marina West Academy of Environmental Science & Creative Arts thanked the Board for the opportunity to showcase the students at Marina West and presented a video produced by students.

PRESENTATION MARINA WEST ACADEMY OF ENVIRONMENTAL SCIENCE & CREATIVE ARTS

President Morrison thanked the students, parents and staff for participating in the board meeting.

A.5 Changes to the agenda were noted:

- Tabled A.12 Recognition of Driscoll’s & Berry Farm to a future meeting.

ADOPTION OF THE AGENDA

On motion by Trustee Cordes, seconded by Trustee Robles-Solis and carried on a roll call vote of 5-0; the Board adopted the agenda, as amended.

A.6 Ms. Robin Freeman, Assistant Superintendent, Educational Services, introduced Dr. Ana DeGenna, Director of Dual Language Programs who provided an extensive presentation on Dual Language Immersion Program.

STUDY SESSION DUAL LANGUAGE IMMERSION PROGRAM REPORT

Following discussion, the Board thanked Dr. DeGenna for the report.

ANNOUNCEMENTS PRIOR TO CLOSED SESSION January 18, 2017:

After any public comments on the Closed Session agenda items, the Board will be recessing to Closed Session to consider the following:

No one addressed the Board of Trustees during closed session public comment.

PUBLIC COMMENT CLOSED SESSION

Firstly, for CONFERENCE WITH LEGAL COUNSEL under *Government Code*, Section 54956.9:

- ANTICIPATED LITIGATION – one (1) case

- EXISTING LITIGATIONS:
Office of Administrative Services Case Nos.: 2016100075
2016100053, 2016100074, 2016090944, 2016091095, 2016091112,
2016091008, 2016100073, 2016091036, 2016100054, 2016100066,
2016100009, 2016100031, 2016110811, 2017010078

Secondly, for CONSIDERATION OF STUDENT MATTERS, under Government Code, 48916:

- Consider the Request to Readmit Expelled Students:
Case No. 15-09 (Action Item)
Case No. 15-17 (Action Item)
Case No. 15-19 (Action Item)

Thirdly, for CONFERENCE WITH LABOR NEGOTIATORS under *Government Code*, Sections 54957.6 and 3549.1.

The District negotiator is the Assistant Superintendent, Human Resources & Support Services and the employee organizations are OEA, OSSA, CSEA; and all unrepresented personnel – administrators, classified management, confidential.

Fourthly, for CONFERENCE WITH REAL PROPERTY NEGOTIATORS under Government Code, Section 54956.8:

- Property: Parcel located Teal Club Road, North of Teal Club Road, South of Doris Avenue; Agency Negotiators: Superintendent/Deputy Superintendent, Business & Fiscal Services/Garcia Hernandez & Sawhney, LLP/Caldwell Flores Winters, Inc.

Finally, under *Government Code*, Section 54957 and *Education Code*, Section 44943:

- PUBLIC EMPLOYEE(S) DISCIPLINE/DISMISSAL/RELEASE

Trustees convened to closed session at 6:35 p.m. until approximately 7:18 p.m. to discuss items on the closed session agenda. CLOSED SESSION

President Morrison reported the Board would be returning to closed session after the regular board meeting to complete the items on the closed session agenda. REPORT ON CLOSED SESSION

The Board of Trustees recognized 49 students that were present for the board meeting who had read one million words with a t-shirt that stating “I read 1,000,000,00 words, what’s your super power?”. RECOGNITION OF OXNARD SCHOOL DISTRICT’S MILLION WORD READERS

B.1 Clerk Cordes read the Rules For Individual Presentations in English and in Spanish. RULES FOR PRESENTATIONS

The following individual addressed the Board of Trustees: PUBLIC COMMENT

- Ilene Poland, CSEA President introduced Marcella Flores, Chapter Treasurer and Hugo Alcala Chapter Public Relations Officer and stated she looked forward to a productive year.
- Daniel Chavez Jr., concerned citizen, expressed concern with the housing, schools and violence in the community.

- Daniel Chavez Jr., concerned with consent item on agenda regarding Elm School and requested Board reconsider to add more classrooms.

The following items on the consent agenda were approved on motion by Trustee Madrigal Lopez seconded by Trustee Robles-Solis, and carried on a roll call vote of 5-0, as amended.

CONSENT AGENDA
(Motion #16-66)

C.1 Acceptance of Gifts

(Acceptance of Gifts)

- From Fremont PTA, a donation of an Elkay Water Hydration Station to Fremont Academy, that will be used to support students.

C.2 Approved the following agreements:
Enrichment:

(Approval of
Agreements)

- #16-197 with Focus on the Masters, to provide art lessons during school hours to Harrington students in grades 3-5; amount not to exceed \$4,500.00, to be paid with Targeted General Funds;
- #16-211 with Antonio F. Jimenez Jimenez, to provide professional development to teachers in the Oxnard School District during the 2016-2017 school year; amount not to exceed \$8,000.00, to be paid with Title I Funds;
- #16-212 with Parent Institute for Quality Education (PIQE), to provide a nine week parent training course in Spanish for the parents of the children enrolled at McKinna School during the period of January 26, 2017 through March 30, 2017; amount not to exceed \$6,000.00, to be paid with EL Targeted General Funds;
- #16-217 with The Entertainment Contractor, to make and install 10 tons of snow which may or may not include a snow sled run at R.J. Frank Academy of Marine Science & Engineering on January 28, 2017; educational connections with snow will be made with respect to climate and weather and the many human and animal adaptations that result from colder environments; amount not to exceed \$7,600.00, to be paid \$4,950.00 MSAP Grant Funds and \$2,650.00 General Funds;
- #16-218 with Carl Abajian (Captain Carl's Mobile Tidepool), to deliver and set-up a marine touch tank and provide four hours of hands-on marine science education to students and parents at R.J. Frank Academy of Marine Science & Engineering on January 28, 2017; amount not to exceed \$800.00, to be paid with MSAP Grant Funds;
- #16-224 with Focus On The Masters, to provide "Learning To See Program" to Sierra Linda fifth grade students; amount not to exceed \$2,000.00, to be paid with Non-Targeted General Funds;

Special Education:

- Amendment #1 to Agreement #16-86 with Ventura County Office of Education/SELPA, to provide OT/COTA services for 68 hours a week for 48 weeks in the amount not to exceed \$228,480.00, Amendment #1 is to reduce to 44 hours per week in turn reducing the new total agreement amount to \$161,280.00, to be paid with Special Education Funds;
- #16-198 with Behavior Insights Inc., to provide consultant services to OSD, Special Education Services during the 2016-17 academic school year; amount not to exceed \$15,000.00, to be paid with Special Education Funds;

Support Services:

- #16-204 with Ventura County Office of Education to facilitate and acknowledge the mutual sharing of data and integration between data management systems, January 19, 2017 through January 18, 2022; hourly rates not to exceed \$80.00 - \$150.00 and will be invoiced as needed, to be paid with Unrestricted General Funds;
- #16-205 with Hip Hop Mindset, to provide hip hop dance lessons to students in the Oxnard School District, January 19, 2017 through June 30, 2017; amount not to exceed \$45,000.00, to be paid with ASES Grant Funds;
- #16-213 with Foster Youth Services Coordinating Program, VCOE, to provide training for the Training Informed Practices for Schools to certified teachers at McKinna School, January 19, 2017 through June 30, 2017; the District will be reimbursed by FYSCP for participation;
- #16-214 with Professional Tutors of America Inc., to provide free One on One tutoring services to Title One eligible students in the Oxnard School District, January 20, 2017 through June 30, 2017; amount not to exceed \$900.00 per student, to be paid with Title One – SES Funds (\$60.00 per hour for a maximum of 15 hours per student);
- #16-215 with Ventura County Office of Education, to provide free small group (10:1) tutoring services to Title One eligible students in the Oxnard School District, January 20, 2017 through June 30, 2017; amount not to exceed \$900.00 per student, to be paid with Title One – SES Funds (\$36.00 per hour for a maximum of 25 hours per student);
- #16-216 with Tutorific, to provide free One on One or small group (6:1) tutoring services to Title One eligible students in the Oxnard School District, January 20, 2017 through June 30, 2017; amount not to exceed \$900.00 per student, to be paid with Title One – SES Funds (\$60.00 per hour for a maximum of 15 hours per student or \$36.00 per hour for a maximum of 25 hours per student);
- #16-219 with Terra Firma Enterprises, to provide the Emergency Operations Center (EOC) Essential Course to the Oxnard School District; amount not to exceed \$8,450.00, to be paid with Safety Credits Fund;
- #16-220 with Terra Firma Enterprises, to provide technical assistance to update the Emergency Operations Plan (EOP) and operational checklists for Oxnard School District's EOC; amount not to exceed \$8,190.00, to be paid with Safety Credits Fund;
- #16-225 with Parsons Constructors Inc., to support the Project Labor Agreement for the Elm Elementary School Project, January 19, 2017 through July 31, 2018; amount not to exceed \$49,000.00, to be paid with Measure R Bond Funds;

Personnel:

- #16-223 with Liberty University, to establish a partnership to provide candidates an opportunity to complete their degree in School Counseling; at no cost to the District;

Facilities:

- #16-208 with Flewelling and Moody, Inc., to provide preliminary architectural and engineering services for the Doris/Patterson Site; services to be provided on an hourly basis, not to exceed \$150,000.00, to be funded with Measure "R" Bond Funds.

C.3 Ratified the following agreements:

(Ratification of Agreements)

Academic:

- Amendment #1 to Agreement #16-44 with California Department of Education, to ratify Child Development Division Contract #CSPP-6635, original agreement was for \$1,196,273.00, Amendment #1 is for an increase of \$61,446.00, for a new total of \$1,257,719.00;

Enrichment:

- #16-222 with Art Trek Inc., to provide art enrichment for students participating in the after school programs at various sites; amount not to exceed \$32,400.00, to be paid with ASES Grant Funds;

Special Education:

- Amendment #1 to Agreement #16-113 with Casa Pacifica School, original agreement for student ZH020603 was in the amount not to exceed \$39,600.00; Amendment #1 is to provide intensive individualized services (1:1 Paraeducator) for same student for an increase of \$21,300.00, for a total of \$60,900.00 for 2016-17; to be paid with Special Education Funds;
- #16-186 with Assistance League, Non-Public School, to provide services for students IM062912 and EV120612 for the 2016-2017 school year, including Extended School Year, beginning November 1, 2016; amount not to exceed \$12,560.00, to be paid with Special Education Funds;
- #16-196 with Teaching Learning Creating, Plus (TLC+), Non-Public School, to provide services for student NC072504 for the 2016-2017 school year, including Extended School Year; amount not to exceed \$25,120.08, to be paid with Special Education Funds;
- #16-206 with Casa Pacifica Non-Public School, to provide services for student GS021503 for the 2016-2017 school year, including Extended School Year; amount not to exceed \$26,022.00, to be paid with Special Education Funds;
- #16-209 with Ventura County Office of Education, to provide exceptional services to special education students GG111606, JP030904, EN071309, and JS010805 that consist of support from Special Circumstances Paraeducators (SCP's) for the 2016-2017 school year, including Extended School Year; amount not to exceed \$28,927.10, to be paid with Special Education Funds;
- #16-221 with Ventura County Office of Education, to provide exceptional services to special education students PL031809 and BE053005 that consist of support from Special Circumstances Paraeducators (SCP's) for the 2016-2017 school year, including Extended School Year; amount not to exceed \$48,711.76, to be paid with Special Education Funds;

Personnel:

- Amendment #1 to Agreement #14-43 with National University – Internship Credential Program, Amendment #1 is to revise language on Article 8 to meet State regulations regarding Teacher and Special Education Intern Support; District will pay National University Interns on the Certificated Salary Schedule from the Unrestricted General Fund;

Facilities:

- #16-202 with Nolte Associates Inc., to provide additional soil testing and analysis requested by The California Geological Survey for the portable Classrooms Addition at San Miguel School; amount not to exceed \$9,480.00, to be paid with Deferred Maintenance Funds.

- C.4 Approved the 2016-17 Quarterly Report on Williams Uniform Complaints, second quarter, as presented. (Approval of the 2016-17 Quarterly Report on Williams Uniform Complaints, Second Quarter)
- C.5 Approved request for MSAP Project Director Ms. Debra West to attend the Magnet Schools of America National Policy Training Conference in Washington, D.C., February 15 – 17, 2017; amount not to exceed \$3,500.00, to be paid with MSAP Grant Funds. (Approve Request to Attend Out-of-State Conference, Washington, D.C.)
- C.6 Approved student participation in the Crossing of the Channel Program overnight field trips; Fremont - April 17-19, 2017, and Frank - April 19-21, 2017, April 23-26, 2017 and April 26-28, 2017; at no cost to the District. (Approval of Overnight Field Trip to CSU Channel Islands Santa Rosa Islands)
- C.7 Accepted and adopted the December 2016 Master Construct and Implementation Program. (Approval and Adoption of the December 2016 Master Construct and Implementation Program)
- C.8 Approved student participation in the outdoor Environmental Science Education overnight fieldtrip at NatureBridge located in the Santa Monica Mountains, March 27-29, 2017; the total including insurance and round-trip bus transportation is not to exceed \$9,000.00, to be paid from the Donation – Science Camp Fund. (Approval of Overnight Field Trip and Agreement #16-210 – NatureBridge Lemonwood School)
- C.9 Authorized the Superintendent to make certain changes to the construction documents including modifying the sublease payment amount and certain non-substantive changes to the construction documents, no fiscal impact. (Authorize Superintendent To Make Certain Non-Substantive Changes To The Construction Services Agreement #16-199 and Sublease Agreement #16-201 Between Bernards and the OSD For The Construction of the Elm K-5 School)
- C.10 Declared the December 2, 2016 list of surplus property obsolete and approve its sale and/or disposal, as permitted by California Code §17546. (Disposal of Surplus Personal Property)
- C.11 Received enrollment reports for the months of October, November and December 2016, as submitted. (Enrollment Reports)
- C.12 Approved Purchase Order/Draft Report #16-05, as submitted. (Purchase Order/Draft Payment Report #16-05)
- C.13 Approved the establishment, abolishment, reduction or increase in hours for classified positions:
Establish:
 - A five hour and forty-five minute, 183 day Paraeducator III, position number 7999, to be established in Special Education department. This position will be established to provide additional support.
(Establish/Abolish/Reduce/Increase Hours Of Positions)

- A five hour and forty-five minute, 183 day Paraeducator III, position number 8000, to be established in Special Education department. This position will be established to provide additional support.
- A four and a half hour, 183 day Paraeducator III, position number 8015, to be established in Special Education department. This position will be established to provide additional support.

Abolish:

- A five and a half hour, 183 day Paraeducator II, position number 193, to be abolished in the Special Education department. This position will be abolished due to the lack of work.
- A two hour and forty-five minute, 183 day Paraeducator II, position number 980, to be abolished in the Special Education department. This position will be abolished due to the lack of work.
- A two hour and forty-five minute, 183 day Paraeducator II, position number 981, to be abolished in the Special Education department. This position will be abolished due to the lack of work.

FISCAL IMPACT:

Cost for Para III-\$27,141 Special Education
 Cost for Para III-\$27,141 Special Education
 Cost for Para III-\$21,248 Special Education
 Savings for Para II-\$25,304 Special Education
 Savings for Para II-\$12,635 Special Education
 Savings for Para II-\$12,635 Special Education

C.14 Personnel Action:

(Personnel Actions)

The following certificated individuals to be employed in the capacities and for the terms indicated, their salaries to be determined in accordance with salary regulations of the District.

(CERTIFICATED)

| <u>Name</u> | <u>Position</u> | <u>Effective Date</u> |
|------------------|-------------------------------------|-----------------------|
| <u>New Hires</u> | | |
| Jessica Vizents | English Language Arts, Frank School | 2016/2017 School Year |
| Michelle Avila | Substitute Teacher | 2016/2017 School Year |
| Vanessa Canchola | Substitute Teacher | 2016/2017 School Year |
| Melissa Douglas | Substitute Teacher | 2016/2017 School Year |
| Silvia Gutierrez | Substitute Teacher | 2016/2017 School Year |
| Gabriela Leon | Substitute Teacher | 2016/2017 School Year |
| Maria Rodriguez | Substitute Teacher | 2016/2017 School Year |
| Kathy Russell | Substitute Teacher | 2016/2017 School Year |
| Kyle Scalise | Substitute Teacher | 2016/2017 School Year |

Intervention Services Provider (less than 20 hours per week not to exceed 75% or 135 days a year)

| | | |
|-----------------------|-------------|------------|
| Aldona Galdikas-Franz | Kamala | 12/12/2016 |
| Robin Varat | Ritchen | 01/09/2017 |
| Karen Miyamoto | Marina West | 01/09/2017 |

Resignation

Randi Perkins Physical Education, Haydock 12/03/2016

Retirement

Margo Harpo Substitute Teacher 11/16/2016

Leave of Absence

Dawn Cutting Kinder, Brekke School 12/03/2016

Emily Reich English Language Arts, Frank 02/04/2017

The following classified individuals to be employed in the capacities and for the terms indicated, their salaries to be determined in accordance with salary regulations of the district, it being understood that classified personnel performing substitute duties will be assigned by the administration and paid in accordance with salary

Name

Position

New Hire

| | | |
|------------------------------|--|------------|
| Chavez, Maria E. | NfL Family Liaison (B), Position #7938 Neighborhoods for Learning 6.0 hrs./180 days | 12/06/2016 |
| Covarrubias, Victoria | IA CELDT (B), Position #2435 Ed. Services 5.5 hrs./183 days | 11/30/2016 |
| Delgado, Daniela | Paraeducator III (B), Position 1956 Special Education 5.75 hrs./183 days | 01/11/2017 |
| Glass, Joshua | Custodian, Position #6449 Lemonwood 4.0 hrs./246 days | 11/30/2016 |
| Gomez, Rebecca | Paraeducator III, Position #7902 Special Education 5.75 hrs./183 days | 12/15/2016 |
| Gurrola, Mishael | Site Technology Technician, Position #2946 Frank 5.0 hrs./246 days | 12/12/2016 |
| Lara, Alexis | Paraeducator III, Position #7851 Special Education 5.75 hrs./183 days | 01/09/2017 |
| Maldonado-Rios, Dalymar | Paraeducator II (B), Position 6717 Special Education 5.75 hrs./183 days | 01/09/2017 |
| Martinez, Samuel | Plumber, Position #72 Facilities 8.0 hrs./246 days | 12/13/2016 |
| Ontiveros, Marisol | Paraeducator III, Position #7878 Special Education 5.75 hrs./183 days | 01/10/2017 |
| Quinn, Emily | Paraeducator III, Position #7850 Special Education 5.75 hrs./183 days | 12/05/2016 |
| Tapia De Cendejas, Alejandra | Preschool Assistant (B), Position #2147 Sierra Linda 3.0 hrs./183 days | 12/08/2016 |
| Zamarripa, Jennifer | Paraeducator II (B), Position #6434 Special Education 5.75 hrs./183 days | 01/09/2017 |
| Valles, Alejandro | Accounting Specialist III, Position #1810 | 01/03/2017 |

Budget & Finance 8.0 hrs./246 days

Limited Term

| | | |
|---------------------------------|----------------------------|------------|
| Castaneda, Crystal | Paraeducator | 12/07/2016 |
| Castillo, Olivia | Clerical | 12/12/2016 |
| Humphrey, Jamie | Paraeducator | 12/06/2016 |
| Koriesa, Azza M. | Paraeducator | 12/01/2016 |
| Macen, Adela | Paraeducator | 11/15/2016 |
| Martinez, Samuel | Paraeducator | 12/09/2016 |
| Navarro Hernandez, Elizabeth | Paraeducator | 11/28/2016 |
| Pacheco, Rita | Paraeducator | 12/12/2016 |
| Rivas Saucedo, Norberto | Grounds Maintenance Worker | 11/22/2016 |
| Stanton, Sadie | Paraeducator | 11/28/2016 |
| Vasquez, Justine | Paraeducator | 12/09/2016 |

Exempt

| | | |
|------------------------|------------------|------------|
| Hernandez, Julie | AVID | 11/14/2016 |
| Castellanos, Sandra | Campus Assistant | 12/01/2016 |
| Cuevas Ayala, Fernando | Campus Assistant | 11/28/2016 |
| Harris, Aaron | Campus Assistant | 11/16/2016 |
| Rodriguez, Julien | Campus Assistant | 12/10/2016 |
| Sanchez, Francisco | Campus Assistant | 12/01/2016 |
| Sepulveda, Jesse | Campus Assistant | 12/05/2016 |

Promotion

| | | |
|--------------------|---|------------|
| Pulido, Daniel | Paraeducator III (B), Position #2683 Special Education 5.75 hrs./183 days Paraeducator II, Position #6734 Special Education 5.75 hrs./183 days | 01/09/2017 |
| Rojas, Elias | Grounds Equipment Operator, Position #421 Facilities 8.0 hrs./246 days Grounds Maintenance Worker I, Position #1173 Facilities 8.0 hrs./246 days | 12/19/2016 |
| Vasquez, Christian | Maintenance Worker I, Position #5845 Facilities 8.0 hrs./246 days Paraeducator II, Position #1805 Special Education, 5.75 hrs./183 days | 01/09/2017 |

Transfer

| | | |
|------------------|---|------------|
| Aspera, Ivan | Custodian, Position #533 Chavez 8.0 hrs./246 days Custodian, Position #632 Lemonwood 8.0 hrs./246 days | 12/05/2016 |
| Rodarte, Maribel | Child Nutrition Worker, Position #2426 Fremont 5.5 hrs./185 days | 12/05/2016 |

| | | |
|----------------------|---|------------|
| | Child Nutrition Worker, Position #7277 Fremont 5.0 hrs./185 days | |
| Rodas, Derick | Site Technology Technician, Position #2207 Kamala 8.0 hrs./246 days | 12/19/2016 |
| | Site Technology Technician, Position #6804 Frank 8.0 hrs./192 days | |
| <u>Reinstatement</u> | | |
| Zamarripa, Jovana | Paraeducator II (B), Position #5561 Special Education 5.75 hrs./183 days | 01/09/2017 |
| <u>Resignation</u> | | |
| Flores, Leonela | Paraeducator I, Position #7194 Sierra Linda 3.10 hrs./183 days | 12/02/2016 |
| Montes, Gladys | Paraeducator I, Position #7260 Soria 5.0 hrs./183 days | 12/16/2016 |
| <u>Retirement</u> | | |
| Herrera, Maria | Instructional Assistant RSP, Position #356 Special Education 5.5 hrs./183 days | 12/30/2016 |
| Jose, Arturo | Custodian, Position #1510 Curren 8.0 hrs./246 days | 04/06/2017 |

D.1 Following discussion, on motion by Trustee O’Leary, seconded by Trustee Cordes and carried on a roll call vote of 5-0; the Board of Trustees approved the Variable Term Waiver for a Clear Multiple Subject Teaching credential for Adriana Camarillo-Salazar, as presented.

APPROVAL OF THE VARIABLE TERM WAIVER FOR A CLEAR MULTIPLE SUBJECT TEACHING CREDENTIAL FOR ADRIANA CAMARILLO-SALAZAR
(Motion #16-67)

D.2 On motion by Trustee Cordes, seconded by Trustee O’Leary and carried on a roll call vote of 5-0; the Board of Trustees approved the Chavez SPSA with the inclusion of the ELAC President’s signature.

APPROVAL OF CHAVEZ SCHOOL SINGLE PLAN FOR STUDENT ACHIEVEMENT
(Motion #16-68)

D.3 Ms. Lisa Cline, Deputy Superintendent, Business & Fiscal Services introduced Mr. Jeff Nigro with Nigro & Nigro who provided a brief report on the process and purpose of an audit. On motion by Trustee O’Leary, seconded by Trustee Robles-Solis and carried on a roll call vote of 5-0; the Board of Trustees accepted the Oxnard School District Audit Report, June 30, 2016.

OXNARD SCHOOL DISTRICT AUDIT REPORT, JUNE 30, 2016
(Motion #16-69)

D.4 On motion by Trustee Cordes, seconded by Trustee Robles-Solis and carried on a roll call vote of 5-0; the Board of Trustees approved Resolution #16-20 of the Board of Trustees of the Oxnard School District Canvassing and Certifying Election Results and Certifying To The Board of Supervisors of Ventura County All Proceedings in the November 8, 2016 General Obligation Bond Election, as presented.

RESOLUTION #16-20 OF THE BOARD OF TRUSTEES OF THE OXNARD SCHOOL DISTRICT CANVASSING AND CERTIFYING ELECTION RESULTS AND CERTIFYING TO

THE BOARD OF
SUPERVISORS OF
VENTURA COUNTY ALL
PROCEEDINGS IN THE
NOVEMBER 8, 2016
GENERAL OBLIGATION
BOND ELECTION
(Motion #16-70)

D.5 Ms. Lisa Cline, Deputy Superintendent, Business & Fiscal Services introduced Mr. Jeff Nigro with Nigro & Nigro who provided a brief report. On motion by Trustee O’Leary, seconded by Trustee Robles-Solis and carried on a roll call vote of 5-0; the Board of Trustees accepted the Measure R General Obligation Bond Building Fund of the Oxnard School District Audit Report, June 30, 2016.

MEASURE R GENERAL
OBLIGATION BOND
BUILDING FUND OF
THE OXNARD SCHOOL
DISTRICT AUDIT
REPORT, JUNE 30, 2016
(Motion #16-71)

D.6 Ms. Lisa Cline, Deputy Superintendent, Business & Fiscal Services presented the process for establishing an oversight committee according to Proposition 39 which requires that within 60 days of Certification of the passage of a bond. She presented for the Board’s consideration a list of potential representatives for the Measure D Bond Oversight Committee (BOC) as well as its corresponding bylaws.

ESTABLISHMENT OF
MEASURE “D” BOND
OVERSIGHT
COMMITTEE

Following discussion, on motion by Trustee Robles-Solis, seconded by Trustee Madrigal Lopez and carried on a roll call vote of 5-0; the Board of Trustees established the Measure D Bond Oversight Committee, pursuant to Proposition 39 and adopted the bylaws, as presented. Ms. Cline also introduced Mr. Pedro Chavez, the representative for the Business Organization, who thanked the Board of the opportunity of being part of the committee.

(Motion #16-72)

D.7 On motion by Trustee Cordes, seconded by Trustee O’Leary and carried on a roll call vote of 5-0; the Board of Trustees adopted and read into record Resolution #16-22 Supporting Commitment to the Education of All Children and Making All Campuses A Safe Zone For Students and Families Threatened by Immigration Enforcement.

CONSIDERATION OF
RESOLUTION #16-22
SUPPORTING
COMMITMENT TO THE
EDUCATION OF ALL
CHILDREN AND
MAKING ALL
CAMPUSES A SAFE
ZONE FOR STUDENTS
AND FAMILIES
THREATENED BY
IMMIGRATION
ENFORCEMENT
(Motion #16-73)

D.8 Dr. Cesar Morales, District Superintendent provided a brief summary on Agreement #12-132 with Caldwell Flores Winters, Inc. for Program Management and Implementation Services. Dr. Morales recommended that the Board of Trustees approve Amendment #1 to Agreement #12-132 to incorporate Measure D Program and clarify the following language to: 1) Term, 6) Independent Contractor Status and Conflict of Interest; and 9) Insurance.

APPROVAL OF
AMENDMENT #1 TO
AGREEMENT #12-132
WITH CALDWELL
FLORES WINTERS, INC.,
FOR PROGRAM
MANAGEMENT AND
IMPLEMENTATION
SERVICES

Following discussion, on motion by Trustee Robles-Solis, seconded by Trustee Madrigal Lopez and carried on a roll call vote of 5-0; the Board of Trustees approved

Amendment #1 to Agreement #12-132 that amended the following sections of Agreement #12-132: 1) Term, 6) Independent Contractor Status and Conflict of Interest, and 9) Insurance; no fiscal impact to the original agreement.

(Motion #16-74)

E.1 On motion by Trustee Cordes, seconded by Trustee O’Leary, and carried on a roll call vote of 4-0-1, Trustee Madrigal Lopez abstained; the Board of Trustees approved the minutes of November 2, 2016, regular board meeting, as submitted.

APPROVAL OF BOARD MINUTES
(Motion #16-75)

F.1 On motion by Trustee O’Leary, seconded by Trustee Cordes and carried on a roll call vote of 5-0; the Board of Trustees reviewed the new and revised Board Policies, Administrative Regulations and Bylaws, listed below, for a second reading and adopted, as presented.

SECOND READING OF BOARD POLICIES, ADMINISTRATIVE REGULATIONS AND BYLAWS

| | | |
|------------------------------------|--|-------------------|
| Revision BP 1312.3 and AR 1312.3 | Community Relations UNIFORM COMPLAINT PROCEDURES | Vaca |
| Revision AR 1312.4 and E(2) 1312.4 | Community Relations WILLIAMS UNIFORM COMPLAINT PROCEDURES | Vaca |
| Revision AR 3311 | Business and Noninstructional Operation BIDS | Cline |
| Revision AR 3580 | Business and Noninstructional Operation DISTRICT RECORDS | Vaca |
| Revision BP 5116.1 and AR 5116.1 | Students INTRADISTRICT OPEN ENROLLMENT | Freeman/ Ridge |
| Revision E 9270 | Board Bylaws CONFLICT OF INTEREST | Cline |

(Motion #16-76)

Dr. Cesar Morales:

- Wished everyone a Happy New Year and was excited to recognize all of the students earlier that had read one, two and three million words. Thanked Ms. Curtis and the staff in Educational Services for their efforts in promoting accelerating literacy.
- Reported that schools that have been showcasing to the Board during the meetings have provided hands on activities in classrooms and students performing the activities that are strand focused and intervention to be responsive to our students.
- Reported he had been working with other feeder school districts into Oxnard Union High School District, as well as Ventura County Office of Education, and CSUCI and CLU on the P-20 Council, and would be providing more information at a future date.
- Reported he is also working on a program where OSD students who will attend Hueneme or Channel Islands High Schools are part of a promise for 8th, 9th, 10th, 11th and 12th graders to attend California Lutheran College or California State University, Channel Islands or Oxnard College for two years without paying tuition.
- Thanked Dr. DeGenna for raising the bar with the awesome presentation she provided earlier on Dual Language Leadership.
-
- President Morrison shared a video of Dr. Cesar Morales, District Superintendent who was selected as an awardee by Education Week for 2017 as a “Leader To

SUPERINTENDENT ANNOUNCEMENTS

Learn From” an annual special report that spotlights innovative school district leaders around the nation.

Ms. Monica Madrigal Lopez:

- Reported last week she visited Rose Avenue, Cesar Chavez, Ramona, Frank, Brekke and Curren Schools. She was an alumni and did her internship at Frank Middle School, so it was a privilege to walk the campus and visit classrooms and meet with students, teachers and staff. She shared she spoke with one student that shared the impact of taking a robotic class and how it had affected his future.
- Reported she participated in the Martin Luther King Jr. March on Monday which was a great experience to walk with so many people from the community.
- Thanked Dr. Ana DeGenna for her presentation.
- Stated she was happy that the Oxnard School District is a safe zone for students and families.

TRUSTEE
ANNOUNCEMENTS

Mrs. Veronica Robles-Solis:

- Reported it was great to see the entire Oxnard School District Board of Trustees participate in the Martin Luther King Jr. March.
- Reported today she toured Ramona School and visited Ms. Sims class, the 4th grade class that is participating in the Latino Film Institute Youth Cinema Project which has motivated the students to write their own scripts, engage with the camera and build confidence. She reported the movie should be completed in May and is looking forward to viewing the final product.
- Congratulated the five students that received an award for participating in the 12th District PTA Reflection Event and looked forward to seeing more students participate next year.

Mr. Denis O’Leary:

- Reported he was excited and proud of the Oxnard School District for passing the safe zone resolution and reported we have always been a district that supports the students, families and community. He stated Cesar Chavez went to our schools and the movement started in Oxnard. He reported that the school district has passed similar resolutions in the past including boycotting Arizona.
- Requested to review in the near future: Plaza Comunitaria, discuss class size reduction, discuss less classrooms being built in the reconstruction of Elm School, we need to plan for the population of our community that we serve for the future. Discuss the Living Wage which should be done annually and possibly raising to \$15.00. Discuss Project Labor Agreement, let us hire local workers for our projects, consider a blanket policy that all future construction projects have a PLA. Dr. Morales informed the Board that current laws provides for PLAs for projects.

Mrs. Debra M. Cordes:

- Congratulated Dr. Morales on his recognition by Education Week and thanked him for the video it was great and supports the mission of student reading.
- Stated she supports the work being done by Caldwell Flores Winters, Inc. but as a Board Member and representative of the community, she will bring questions to the surface which need to be answered; ultimately she will support the Team.
- Thanked Mr. Chavez for addressed the Board earlier regarding housing, schools and violence on the up raise in the community.
- Stated the Board needs to collaborate and support staff, teachers, principals and parents that address the Board with their concerns. In regards to Elm School, more

classrooms could mean bigger schools and/or more students, they need to check into the concerns and come up with a solution that works for everyone.

- Reported she participated in the cheering sections at Lemonwood and Soria Schools for Santa to The Sea. She also attended the program at San Miguel School which the students really enjoyed, especially the Santa Claus.
- Reported she also attended the PTA Reflection Event and it was nice to see the students.
- Reported she also attended a special meeting regarding the Power Plant in Oxnard and one of the lead speakers for CAUSE was a former Harrington Bear student who had won several speech contests throughout the years.
- Stated she also participated in the Martin Luther King Jr. March on Monday and went and saw the movie Hidden Figures which was very good.
- She thanked Dr. DeGenna for her presentation.

Mr. Ernest Morrison:

- Reported he thoroughly enjoyed the Martin Luther King Jr. March on Monday. He also spoke with several attendees that did not stay for the program because it cost too much money. He suggested some assistance be provided to the committee to have a reserve of funds for those that could not pay for the program.
- Announced that on February 4, 2017 is the Oxnard School District Education Foundation Gala, fund raiser for grants that go directly to teachers in our district.

Trustees reconvened to closed session at 9:35 p.m. until approximately 10:46 p.m. to discuss items on the closed session agenda. CLOSED SESSION

President Morrison reported the Board deliberated on student matters in closed session and will take action in open session: REPORT ON CLOSED SESSION

- On motion by Trustee Cordes seconded by Trustee O’Leary and carried on a roll call vote of 5-0; the Board of Trustees approved to not readmit student in Case No. 15-09. (Motion #16-77)
- On motion by Trustee O’Leary seconded by Trustee Madrigal Lopez and carried on a roll call vote of 5-0; on the Board of Trustees approved to readmit student in Case No. 15-17. (Motion #16-78)
- On motion by Trustee O’Leary seconded by Trustee Madrigal Lopez and carried on a roll call vote of 5-0; the Board of Trustees approved to readmit student in Case No. 15-19. (Motion #16-79)

There being no further business, on motion by Trustee Cordes, seconded by Trustee Robles-Solis, President Morrison adjourned the meeting at 10:50 p.m. ADJOURNMENT

Respectfully Submitted,
DR. CESAR MORALES

District Superintendent and
Secretary to the Board of Trustees

By our signature below, given on this _____ day of _____, 20____, the

Governing Board of the Oxnard School District approves the Minutes of the Regular Board meeting of January 18, 2017; on motion of Trustee _____, seconded by Trustee _____.

Signed:

President of the Board of Trustees

Clerk of the Board of Trustees

Member of the Board of Trustees

Member of the Board of Trustees

Member of the Board of Trustees

Regular Board Meeting
February 1, 2017

The Board of Trustees of the Oxnard School District met in regular session at 5:00 p.m. on Wednesday, February 1, 2017, at the Educational Service Center.

CALL TO ORDER

A roll call of the Board was conducted. Present were President Ernest “Mo” Morrison and Trustees Debra M. Cordes, Veronica Robles-Solis and Monica Madrigal Lopez. Trustee Denis O’Leary reported he would be arriving late to the meeting. Staff members present were District Superintendent Dr. Cesar Morales, Deputy Superintendent Lisa Cline and Assistant Superintendents Robin Freeman and Dr. Jesus Vaca, and executive assistant Sylvia Carabajal.

ROLL CALL

Rosie Gonzalez, 8th grader in Ms. Lauren Mendez’ class, student at Haydock Academy of Arts & Sciences, lead the audience in the Pledge of Allegiance.

PLEDGE OF ALLEGIANCE

Viridiana Corona, 8th grader in Ms. Rana Kalaj’s class, student at Haydock Academy of Arts & Sciences, read the District’s Vision and Mission Statements in English and Spanish.

DISTRICT’S VISION AND MISSION STATEMENTS

Dr. Edd Bond, Principal at Haydock Academy of Arts & Sciences thanked the Board for the opportunity to showcase the students and programs at Haydock Academy and provided a presentation the many things that are happening at his school. Dr. Bond announced the mural unveiling at Haydock on Wednesday, February 15, 2017, the Project Based Learning Exhibition on Thursday, April 27, 2017 at 5:30 p.m. to 7:00 p.m. at Haydock Academy, and the Spring Showcase with is scheduled for June 8, 2017 at 6:00 p.m. to 7:30 p.m. at the PACC.

PRESENTATION HAYDOCK ACADEMY OF ARTS & SCIENCES

President Morrison thanked the students, parents and staff for participating in the board meeting.

The Board of Trustees recognized Haydock students that were present for the board meeting who had read one million words with a t-shirt that stating “I read 1,000,000 words, what’s your super power”.

RECOGNITION OF OXNARD SCHOOL DISTRICT’S MILLION WORD READERS

A.6 Changes to the agenda were noted:

- Moved item C.12 Approval of Job Duties & Salary Allocation for New Classification (Job Description) Senior Manager – Maintenance & Operations to D.3 at the request of Trustee Robles-Solis.

ADOPTION OF THE AGENDA

On motion by Trustee Robles-Solis, seconded by Trustee Cordes and carried on a roll call vote of 4-0; the Board adopted the agenda, as amended.

A.7 Ms. Robin Freeman, Assistant Superintendent, Educational Services, introduced Mr. Chris Ridge, Director of Pupil Services who provided a presentation on “Educating the Whole Child”, the important role of support staff in our schools and community.

STUDY SESSION SCHOOL SITE SUPPORT PERSONNEL

Following the presentation, Mr. Ridge introduced the Counselors and Outreach Specialists from each of the school site.

The Board thanked the Counselors and Outreach Specialists that were in attendance and thanked Ms. Freeman and Mr. Ridge for the report.

ANNOUNCEMENTS PRIOR TO CLOSED SESSION February 01, 2017:

After any public comments on the Closed Session agenda items, the Board will be recessing to Closed Session to consider the following:

No one addressed the Board of Trustees during closed session public comment.

PUBLIC COMMENT
CLOSED SESSION

Firstly, for CONFERENCE WITH LEGAL COUNSEL under *Government Code*, Section 54956.9:

- ANTICIPATED LITIGATION – one (1) case
- EXISTING LITIGATIONS: (2 cases)
Office of Administrative Services Case Nos.: 2016100075 and 2016100073,

Secondly, for CONFERENCE WITH LABOR NEGOTIATORS under *Government Code*, Sections 54957.6 and 3549.1.

The District negotiator is the Assistant Superintendent, Human Resources & Support Services and the employee organizations are OEA, OSSA, CSEA; and all unrepresented personnel – administrators, classified management, confidential.

Thirdly, for CONFERENCE WITH REAL PROPERTY NEGOTIATORS under *Government Code*, Section 54956.8:

- Property: Parcel located Teal Club Road, North of Teal Club Road, South of Doris Avenue; Agency Negotiators: Superintendent/Deputy Superintendent, Business & Fiscal Services/Garcia Hernandez & Sawhney, LLP/Caldwell Flores Winters, Inc.

Finally, under *Government Code*, Section 54957 and *Education Code*, Section 44943:

- PUBLIC EMPLOYEE(S) DISCIPLINE/DISMISSAL/RELEASE
- PUBLIC EMPLOYEE(S) EVALUATION:
 - Deputy/Assistant Superintendents

Trustees convened to closed session at 5:45 p.m. until approximately 7:16 p.m. to discuss items on the closed session agenda.

CLOSED SESSION

Trustee Denis O’Leary arrived at 6:15 p.m.

(Arrival of Trustee)

President Morrison reported the Board would be returning to closed session after the regular board meeting to complete the items on the closed session agenda.

REPORT ON CLOSED
SESSION

The Board of Trustees recognized 22 McAuliffe School students that were present for the board meeting who had read one million or more words with a t-shirt that stating “I read 1,000,000 words, what’s your super power”.

RECOGNITION OF
OXNARD SCHOOL
DISTRICT’S MILLION
WORD READERS

Ms. Anna Thomas, Director of Curriculum, Instruction and Accountability provided a brief summary of the donations provided by Driscoll's and Berry Pack to the Migrant families in Oxnard. Mr. Ray Pena from Driscoll's accepted the plaque for Berry Pack and thanked the Board of Trustees for the opportunity which has been going on for several years.

RECOGNITION OF DRISCOLL'S AND BERRY PACK ON BEHALF OF MIGRANT FAMILIES

On motion by Trustee O'Leary, seconded by Trustee Cordes and carried on a 5-0 roll call vote; the Board of Trustees adopted and read into record Resolution #16-21 In Recognition of National School Counseling Week, February 6-10, 2017.

RESOLUTION #16-21 RECOGNITION OF COUNSELORS AND ORCs

Ms. Robin Freeman, Assistant Superintendent, Educational Services provided a presentation on teaching and learning for reading achievement for all students. Following discussion, the Board recommended providing different programs for parents to utilize at home. One recommendation was to put lessons up using the District's O.P.I.E. TV which already goes into the homes.

REPORT ON FOUNDATION FOR INCREASED STUDENT ACHIEVEMENT

Ms. Robin Freeman, Assistant Superintendent, Educational Services introduced Ms. Ann Jenks, Principal at McKinna School and Dr. Andrea Pulido, Extra Support Teacher at McKinna School provided an in-depth presentation on the Apple Research Project they participated in 2015-2016 and continued this year at McKinna School. Following discussion, the Board of Trustees thanked Ms. Jenks and Dr. Pulido for the data driven presentation.

PRESENTATION ON MCKINNA SCHOOL'S APPLE RESEARCH

B.1 Clerk Cordes read the Rules For Individual Presentations in English and in Spanish.

RULES FOR PRESENTATIONS

The following individual addressed the Board of Trustees:

PUBLIC COMMENT

- Shari Rason, Classified Employee, concerns with the rising cost of classified employee health and welfare benefits;
- Miguel Perez, Parent of Fremont Student, concern with incident regarding teachers statements;
- Ilene Poland, CSEA President, concerned with the rising cost of classified employee health and welfare benefits and requested immediate solutions.

The following items on the consent agenda were approved on motion by Trustee O'Leary seconded by Trustee Cordes, and carried on a roll call vote of 5-0, as amended.

CONSENT AGENDA (Motion #16-80)

C.1 Approved the following agreements:
Enrichment:

(Approval of Agreements)

- #16-226 with MB Hanrahan, to provide Fremont Academy of Environmental Science and Innovative Design with a mural that represents the academy focus of Science, Technology, Art, Engineering, and Math (STEAM) as part of the school's rebranding efforts; amount not to exceed \$2,500.00, to be paid with Donation Funds;

Special Education:

- Amendment #1 to Agreement #16-71 with STAR of CA, ERA ED, to provide additional classroom support and 1 to 1 behavior therapists for identified students for the 2016-2017 school year; Amendment #1 is for \$60,000.00, original contract was for \$120,000.00, for a total cost of \$180,000.00; to be paid with Special Education Funds;

Facilities:

- #16-207 with SitesPacific, Inc., to provide Land Use Consulting Services related to the acquisition and annexation of the Doris/Patterson site; not to exceed fee of \$50,000.00, to be paid with Measure “R” Bond Funds.

C.2 Ratified the following agreements:

(Ratification of Agreements)

Support Services:

- Amendment #1 to Agreement #16-94 with Angeles Small, to provide additional professional translation services on the English Learner Master Plan; Amendment #1 is for \$500.00, original contract was for \$3,900.00, for a total cost of \$4,400.00, to be paid with Title I Funds.

C.3 Approved a \$2,000.00 annual stipend for mentor principals participating in the CASC program.

(Clear Administrative Services Credential (CASC) Program Mentor Stipend)

C.4 Accepted the “Disclosure of Collective Bargaining Agreement” form for Oxnard Support Services Association (OSSA), as presented.

(Disclosure Of Collective Bargaining Agreement With OSSA)

C.5 Ratified Change Order #1 to Bid #16-INF-02 with GRD Construction in the amount of \$7,787.00; the original price was \$149,270.00. This Change Order will result in a net change of 5.2% and also extends the final completion of the project by twenty-two (22) calendar days.

(Ratification of Change Order #1 to Bid #16-INF-02 ESC Lobby Remodel Project with GRD Construction)

C.6 Ratified Supplemental WAL #001 to WAL #002 with Rincon Consultants, Inc., to provide soil investigation services for the Elm Reconstruction Project; amount not to exceed \$3,161.00, to be paid with Measure “R” Bond Funds.

(Ratification Of Supplemental WAL #001 To WAL #002 With Rincon Consultants Inc., For Soil Investigation Services For The Elm Reconstruction Project)

C.7 Ratified Change Order No. 002 to the Construction Services Agreement #15-198 with Swinerton Builders, to provide construction services related to the Lemonwood Reconstruction Project; amount not to exceed \$13,234.17, to be paid with Measure “R” Bond Funds.

(Ratification of Change Order No. 002 To The Construction Services Agreement #15-198 With Swinerton Builders For The Lemonwood K-8 School Reconstruction)

C.8 Ratified Change Order No. 002 to Bid #16-INF-01 with Fence Factory for the Harrington School Fence Project 2016; amount not to exceed \$3,951.14, to be paid with Measure “R” Bond Funds.

(Ratification of Change Order No. 002 To Bid #16-INF-01 With Fence Factory For The Harrington School Fence Project 2016)

C.9 Approved request for Ms. Robin Freeman, Assistant Superintendent, Educational Services, Dr. Ana DeGenna, Director of Dual Language Programs, and the following seven Principals (Brasilia Perez – Chavez, Kelly Castillo – Curren, Carol Flores Beck – Driffill, Leticia Ramos – Elm, Christine McDaniels – Kamala, Sally Wennes – Lemonwood, and Aracely Fox - Soria, of the Dual Language Schools to visit Mundelein School District and Woodstock School

(Approve Request To Attend Out-Of-State School Sites – Chicago, Illinois)

District in Chicago, Illinois. To observe the implementation of the Teaching for Biliteracy Framework, on February 26, 2017 through March 1, 2017; not to exceed \$20,000.00 in airfare, ground travel, lodging and meals; to be paid from Allocated General Funds – LCFF - Bilingual Funds.

C.10 Approved the CREDIT derived from Contractor Contingency Allocation No. 003 to the Construction Services Agreement #15-198 with Swinerton Builders, for a net reduction of cost associated with additional items of work related to the Lemonwood Elementary School Project of Measure “R” Program under the Lease-Leaseback delivery method pursuant to Section 17406 of the California Education Code.

(Approval of Contractor Contingency Allocation No. 003 For A Credit To The Lemonwood E.S. Reconstruction Project’s Contractor Contingency For A Reduction Of Cost For Additional Work Associated With The Project)

Contractor Contingency Allocation No. 003 will be a CREDIT to the Contractor Contingency line item of the GMP Construction Services Agreement in the amount of \$1,829.62. The Contractor Contingency is included within the approved total of the Construction Service Agreement for the project; the remaining Contractor Contingency balance after Allocation No. 003 will be \$617,925.22.

C.11 Considered and approved the attached job duties of Transportation Driver.

(Approval of Job Duties For New Classification (Job Description) – Transportation Driver)

C.12 *Moved item to D.3 for discussion at the request of Trustee Robles-Solis.*

(Approval of Job Duties & Salary Allocation for New Classification (Job Description) Senior Manager – Maintenance & Operations)

C.13 Approved the establishment, abolishment, reduction or increase in hours for classified positions:

(Establish/Abolish/Reduce/Increase Hours of Positions)

Establish:

- A four hour, 246 day Warehouse worker/Delivery driver, position number 8027, to be established in the Educational Services department. This position will be established to provide support in the Book Barn.
- A five hour and forty-five minute, 183 day Paraeducator III, position number 8028, to be established in the Special Education department. This position will be established to provide additional support.

FISCAL IMPACT:

Cost for Para III-\$25,790 General fund

Cost for Para III-\$27,141 Special Education

C.14 Personnel Action:

(Personnel Actions)

The following certificated individuals to be employed in the capacities and for the terms indicated, their salaries to be determined in accordance with salary regulations of the District.

(CERTIFICATED)

| <u>Name</u> | <u>Position</u> | <u>Effective Date</u> |
|-------------------|--|-----------------------|
| <u>New Hires</u> | | |
| Alma Garcia | RSP Teacher, Itinerant, Pupil Services | 2016/2017 School Year |
| Jamie Pera | SPED M/M Teacher, Sierra Linda | 2016/2017 School Year |
| Sarah Rodriguez | Psychologist, Pupil Services | 2016/2017 School Year |
| John Ayala | Substitute Teacher | 2016/2017 School Year |
| Dana Bogdanich | Substitute Teacher | 2016/2017 School Year |
| Sarah Chenez | Substitute Teacher | 2016/2017 School Year |
| James Hendrickson | Substitute Teacher | 2016/2017 School Year |
| Brenna Koneval | Substitute Teacher | 2016/2017 School Year |
| Gladys Montes | Substitute Teacher | 2016/2017 School Year |
| Louis Reed | Substitute Teacher | 2016/2017 School Year |
| Kathy Russell | Substitute Teacher | 2016/2017 School Year |
| Ashley Vico | Substitute Teacher | 2016/2017 School Year |
| Jory White | Substitute Teacher | 2016/2017 School Year |

Intervention Services Provider (less than 20 hours per week not to exceed 75% or 135 days a year)

| | | |
|-----------------|--------------|------------|
| Charity Whitney | Sierra Linda | 01/17/2017 |
|-----------------|--------------|------------|

Retirement

| | | |
|------------------|------------------------------------|------------|
| Rhetta Johnstone | Speech Pathologist, Pupil Services | 01/26/2017 |
|------------------|------------------------------------|------------|

Leave of Absence

| | | |
|---------------|-----------------------|------------|
| Shane Morales | Science, Frank School | 01/23/2017 |
|---------------|-----------------------|------------|

The following classified individuals to be employed in the capacities and for the terms indicated, their salaries to be determined in accordance with salary regulations of the district, it being understood that substitute classified personnel and regular classified personnel performing substitute duties will be assigned by the administration and paid in accordance with salary regulations governing the specific assignment: (CLASSIFIED)

| <u>Name</u> | <u>Position</u> | <u>Effective Date</u> |
|-------------------------|--|-----------------------|
| <u>New Hire</u> | | |
| Coronado, Mariana | Attendance Accounting Technician (B), Position #7935 San Miguel 8.0 hrs./210 days | 01/12/2017 |
| <u>Limited Term</u> | | |
| Barajas, Sabrina | Paraeducator | 01/09/2017 |
| Gonzalez Chavez, Blanca | Paraeducator | 01/09/2017 |
| Hill, Shelton | Custodian | 12/01/2016 |
| <u>Exempt</u> | | |
| Aguirre, Anita | Campus Assistant | 01/09/2017 |
| Hernandez, Julie | AVID Tutor | 11/14/2016 |

Transfer

| | | |
|-----------------|--|------------|
| Wagner, Sharon | Custodian, Position #632 Lemonwood 8.0 hrs./246 days | 01/09/2017 |
| | Custodian, Position #6448 Driffill 4.0 hrs./246 days | |
| Whitt, Virginia | School Office Manager (B), Position #7915 San Miguel 8.0 hrs./210 days | 01/29/2017 |
| | Administrative Assistant, Position #6861 Educational Services 8.0 hrs./210 days | |

Demotion

| | | |
|----------------|---|------------|
| Najera, Sandra | Paraeducator I, Position #7181 Marshall 4.0 hrs./183 days | 01/16/2017 |
| | Preschool Assistant (B), Position #2666 San Miguel 3.0 hrs./183 days | |

Resignation

| | | |
|-----------------------|---|------------|
| Bustamante, RosaMaria | Paraeducator III, Position #2000 Special Education 5.75 hrs./183 days | 01/20/2017 |
| Diaz, Martha | District Translator, Position #645 Superintendent’s Office 8.0 hrs./246 days | 01/31/2017 |

D.1 On motion by Trustee Robles-Solis, seconded by Trustee O’Leary and carried on a roll call vote of 5-0, the Board of Trustees approved the Tentative Agreement for the 2016-2017 Collective Bargaining Agreement between the Oxnard School District and the Oxnard Supportive Services Association; the following articles were revised:

| | |
|-------------|-----------------|
| Article 5: | Work Calendar |
| Article 16: | Salaries |
| Article 18: | Fringe Benefits |
| Article 22: | Term |

APPROVAL OF THE OXNARD SCHOOL DISTRICT’S AND THE OXNARD SUPPORTIVE SERVICES ASSOCIATION’S TENTATIVE AGREEMENT FOR THE 2016-2017 COLLECTIVE BARGAINING AGREEMENT (Motion #16-81)

D.2 Ms. Lisa Cline, Deputy Superintendent, Business & Fiscal Services introduced Mr. Scott Burkett, Senior Vice President with Caldwell Flores Winters, Inc., who provided a brief summary on the additional work done to the Lemonwood E.S. Reconstruction Project.

APPROVAL OF DISPERSAL NO. 002 FROM THE LEMONWOOD E.S. RECONSTRUCTION PROJECT’S CONTRACTOR CONTINGENCY FOR PAYMENT OF ADDITIONAL WORK ASSOCIATED WITH THE PROJECT (Motion #16-82)

On motion by Trustee Robles-Solis, seconded by Trustee O’Leary and carried on a roll call vote of 5-0; the Board of Trustees approved Contingency Allocation No. 002 to the Construction Services Agreement #15-198 with Swinerton Builders, for additional items of work related to the Lemonwood Elementary School Project of Measure “R” Program under the Lease-Leaseback delivery method pursuant to Section 17406 of the California Education Code.

Contractor Contingency Allocation No. 002 will be deducted from the Contractor Contingency line item of the GMP Construction Services Agreement in the amount of \$90,740.86. The Contractor Contingency is included within the approved total of the Construction Services Agreement for the project; the remaining Contractor Contingency balance after Allocation No. 002 will be \$616,095.60.

D.3 Ms. Lisa Cline, Deputy Superintendent, Business & Fiscal Services provided a brief summary of the process for new classification (job description) through the Personnel Commission. Following discussion, on motion by Trustee O’Leary, seconded by Trustee Robles-Solis and carried on a roll call vote of 5-0; the Board of Trustees approved the job duties and recommended salary allocation for Senior Manager, Maintenance & Operations.

APPROVAL OF JOB DUTIES & SALARY ALLOCATION FOR NEW CLASSIFICATION (JOB DESCRIPTION) SENIOR MANAGER – MAINTENANCE & OPERATIONS (Motion #16-83)

F.1 The Board of Trustees reviewed the new and revised Board Policies, Administrative Regulations and Bylaws, as presented for a first reading:

FIRST READING OF BOARD POLICIES, ADMINSTRATIVE REGULATIONS AND BYLAWS

| | | |
|-------------------------|--|-------------------|
| New BP 3470 | Business and Noninstructional Operations DEBT ISSUANCE AND MANAGEMENT | Cline |
| Revision BP and AR 5117 | Students INTERDISTRICT ATTENDANCE | Freeman/ Ridge |

Dr. Cesar Morales:

SUPERINTENDENT ANNOUNCEMENTS

- Stated he was very proud of the evolution that the board presentations had taken as they are highlighting the many student accomplishments. The District continues to see all of the veracious reading that exist in the community, today we had one student that read 5 million words.
- Reported at the County level Soria and Haydock would be presenting at the 10th Annual RtI2/MTSS/PBIS Symposium on February 1, 2017.
- Reported that Ms. Jenks, Dr. Pulido and Ms. Freeman presented at Apple Headquarters in Cupertino, California.
- Congratulated the School Counselors and ORCs for the tremendous assistance they provide to the students, staff and families in the community.
- Stated that Oxnard School District will remain a safe haven for all students.

Ms. Monica Madrigal Lopez.:

TRUSTEE ANNOUNCEMENTS

- Congratulated all of the students honored tonight for their reading.
- Reported she had the opportunity to attend the Discover Oxnard Middle School event on Saturday, January 28, 2017, and saw firsthand what opportunities are available for the students of the Oxnard School District.
- Thanked the Counselors and the ORCs for their hard work in helping out the future leaders.

Mrs. Veronica Robles-Solis:

- Encouraged parents to take advantage of the programs, training and classes that are being provided by the district and school sites.
- Stated in listening to the parent that spoke during public comment, the Board and District need to be vigilant in making sure that students feel that they are safe in our school sites.

Mr. Denis O’Leary:

- Reported on Friday he was invited to speak on Radio Indigena with parents to see how they can protect their families and be secure themselves. He stated he was proud of the Oxnard School District for supporting the community in safe schools.

- Reported he has also been invited to address City Council on the same topic.
- Request items to discuss in the near future: PLA on any future construction projects in the city; and discuss Plaza Comunitaria to support families and children through education.

Mrs. Debra M. Cordes:

- Thanked the Counselors and the Outreach Specialists for the impact they provide to the families of this community.
- Announced the Oxnard School District Education Foundation Gala Fundraiser was scheduled for Saturday, February 4, 2017. Remarked the remodeling of the front lobby looks very nice.
- Reported on January 26, 2017, she observed the CNS Education Harvest of the Month Lesson at Chavez School and stated it was a neat concept, the vegetable of the month was Kale, so they had a delicious salad. She also visited the Chavez Garden.
- Requested a report on report cards to see how they correlate with what is being taught and how they determine the grades; a report on student redesignation.
- Reported she also drove by Lemonwood School and it is going up quite quickly, it looks great.

Mr. Ernest Morrison:

- Reported there is lot of things happening and reminded the Board of the Oxnard School District Education Foundation Fundraiser Gala on Saturday, February 4, 2017 at the Saticoy Country Club.
- Reported he is receiving calls and notices for the Dr. Seuss Celebration on March 2, 2017.
- Reported that the African American Speech Expo is scheduled for the end of February.

Trustee O’Leary departed at 9:13 p.m.

(Departure of Trustee)

Trustees reconvened to closed session at 9:13 p.m. until approximately 9:57 p.m. to discuss items on the closed session agenda.

CLOSED SESSION

President Morrison reported the Board took no reportable action during closed session.

REPORT ON
CLOSED SESSION

There being no further business, on motion by Trustee Cordes, seconded by Trustee Robles-Solis, President Morrison adjourned the meeting at 9:58 p.m.

ADJOURNMENT

Respectfully Submitted,
DR. CESAR MORALES

District Superintendent and
Secretary to the Board of Trustees

By our signature below, given on this _____ day of _____, 20____, the Governing Board of the Oxnard School District approves the Minutes of the Regular Board meeting of February 1, 2017; on motion of Trustee _____, seconded by Trustee _____.

Signed:

President of the Board of Trustees

Clerk of the Board of Trustees

Member of the Board of Trustees

Member of the Board of Trustees

Member of the Board of Trustees

BOARD AGENDA ITEM

Name of Contributor: Lisa Cline

Date of Meeting: March 1, 2017

- STUDY SESSION _____
- CLOSED SESSION _____
- SECTION A-1: PRELIMINARY _____
- SECTION A-II: REPORTS _____
- SECTION B: HEARINGS _____
- SECTION C: CONSENT AGENDA _____

Agreement Category:

- _____ Academic
- _____ Enrichment
- _____ Special Education
- _____ Support Services
- _____ Personnel
- _____ Legal
- _____ Facilities

SECTION D: ACTION _____

SECTION F: BOARD POLICIES 1ST Reading _____ X 2nd Reading _____

1st READING - REVISION TO AR 3350 – TRAVEL EXPENSES (Cline)

This revision is to remove a reference to “*Assistant Superintendent, Business & Fiscal Services*” and replace it with “*designee*” in order to align with the terminology used throughout all other portions of BP 3350.

Revised/added language is indicated by *italicized* font and deleted language is indicated in strikethrough.

FISCAL IMPACT

None.

RECOMMENDATION

It is the recommendation of the Deputy Superintendent, Business & Fiscal Services, that the Board of Trustees approve the revision to AR 3350 as presented.

ADDITIONAL MATERIAL

Attached: AR 3350 (3 pages)

Travel Expenses

Attendance at meetings or conferences outside the limits of the district is one of the valuable means of maintaining contact with other individuals who are performing the same type of work and who have the same type of interest. It also helps assure to the school district a staff of individuals who are well informed in their particular fields of endeavor. Within the limitations of the budget, as well as other practical aspects which may be related, attendance of personnel at conferences and meetings is encouraged. For the most part such attendance is suggested for individuals who are in a position to disseminate the benefits of the conference attendance among a fairly large percentage of the staff, or for individuals whose responsibilities involve working with other staff members.

The following procedures constitute the policy of the district relative to attendance at conferences.

1. Each individual assigned to a function which is performed as a part of the Educational Services Division, Business and Fiscal Services Division, or the Human Resources Division shall, before making plans to attend a meeting or conference secure approval of the Superintendent or designee.
2. Prior to attendance at any conference, the person planning to attend should secure from the Superintendent or designee a clear understanding of the extent to which expenses for such attendance will be borne by the district and the length of time during which the absence of the individual from the district will be necessitated by attendance at the conference.
3. The term "conference," as used in the preceding paragraphs, includes any meeting, convention, or other gathering which an individual will attend outside of the district, and which necessitates an absence from regular duties in the district.

Payment for Use of Employees' Automobiles

Certain employees use their vehicles in the performance of work for the school district. In cases where such use has been previously authorized an allowance for mileage will be paid in accordance with the provisions of the Board Policy.

Employees in positions requiring the regular use of their automobiles in the performance of their duties may be placed on a monthly flat-rate allowance. An employee to be considered for a flat-rate mileage allowance must have an assignment that:

1. Requires the use of the employee's own automobile in the performance of his/her duties.
2. Reflects a consistent pattern of miles traveled.
3. Requires miles traveled per month, in excess of the minimum miles shown on the schedule of flat-rate allowances set forth in Board Policy and Administrative Procedures.

The average miles per month of required travel shall be certified by the employee's immediate supervisor with the approval of the Superintendent or ~~Assistant Superintendent, Business and Fiscal Services~~ *designee*.

The average miles per month shall be ascertained by comparison of similar job assignments, use of the district mileage chart, and possible requirements of periodic tabulation of actual miles traveled.

In the event of change in assignment that would vary the requirement in travel, the immediate supervisor shall re-certify the monthly flat-rate, requirement.

Monthly flat-rate allowances will be paid only for those months of actual duty. Proportionate deductions will be made for vacation periods, leaves of a week or more in duration, and other extended absences.

Travel Expense Claims

The Education Code provides for payment of "actual and necessary traveling expenses of any employee of the district."

The following regulations are based upon Ventura County governmental policies and are concurred with by the County Auditor, the County Superintendent of Schools, and the district.

This section of the Administrative Procedures is intended to supplement the officially adopted policies of the Board relative to payment of employee expenses for travel on behalf of the district.

1. To receive reimbursement, employees must submit an Expense Reimbursement Voucher to their direct supervisor within 30 days of event.
2. Only "actual and necessary" expense of the employee will be allowed.
3. Each employee must report expenses separately and be paid on separate warrants.
4. Original itemized receipts are required for all conference and travel expenses, including lodging, public transportation (plane, bus, train), meals, and conference registration fees. The request for reimbursement "shall be accompanied by an itemized bill showing the separate items and the price of each." (Education Code 42634) Please refer to AR 3350 for procedure regarding lost receipts.

Original itemized receipt cannot include any alcoholic beverages.

5. Charges for individual meals except for those purchased in connection with formal banquets, group sessions, etc., in which a uniform price is charged to all in attendance, shall not exceed for any single day out of the district, the total amount permitted by the Board Policy and must be accompanied by original itemized receipts.

Expenditures on travel days to and from events outside of Ventura County will be prorated.

6. The following items are not considered "necessary" expenses:

- * Expenses for persons not employed by the district
- * Laundry, valet service, personal phone calls, tips and services
- * Unidentified miscellaneous items

7. Mileage to and from event will be reimbursed to employees. A "Mapquest" or similar document must be submitted to support mileage claim.

Procedure for Lost Receipts

The district Board Policy 3350 stipulates that expenses drawn for any purpose other than the purpose of salaries or wages shall be accompanied by an itemized bill showing the separate items and the price of each. This policy is to establish a procedure to allow reimbursement/payment when the required receipts are lost or destroyed prior to submittal for reimbursement. This procedure shall not apply to reimbursement of non-employee expenses, i.e. Independent Contractors or Workshop speakers.

This policy shall apply to all types of receipts required for all district expense reimbursement when there is no means of obtaining a duplicate receipt, i.e. taxi, parking, meals. It shall not apply to lodging and other receipts which can be replaced by requesting a duplicate from a vendor.

In the event that a receipt is lost or destroyed, the individual employee must submit a "Certification of Lost Receipt" form to the Director of Purchasing for the Superintendent's consideration. Said certification is incorporated herewith as an Exhibit to this policy. The Superintendent or designee will review the certification for validity and approve/deny based on the circumstances; it will then be returned to the individual.

If approved, the certification shall be attached to the corresponding reimbursement claim and will be considered a "receipt" for purposes of the Business Office processing of the claim. If the certification is denied, the request for reimbursement will be considered null and void, and the individual will be held responsible for all expenses incurred in that instance.

Regulation OXNARD SCHOOL DISTRICT

approved: October 19, 2011 Oxnard, California

revised: December 10, 2014; March 15, 2017



OXNARD SCHOOL DISTRICT

1051 South “A” Street • Oxnard, California 93030 • 805/385-1501

SCHEDULE OF BOARD MEETINGS JANUARY – DECEMBER 2017

(UNLESS OTHERWISE INDICATED, ALL MEETINGS ARE HELD ON THE FIRST AND THIRD **WEDNESDAY** OF EACH MONTH IN THE BOARD ROOM AT THE DISTRICT OFFICE, 1051 SOUTH ‘A’ STREET, STARTING AT 7:00 PM)

| | | |
|-----------|----|---|
| January | 18 | Regular Board Meeting (Note: only ONE meeting in January) |
| February | 1 | Regular Board Meeting |
| | 15 | Regular Board Meeting |
| March | 1 | Regular Board Meeting |
| | 15 | Regular Board Meeting |
| April | 19 | Regular Board Meeting (Note: only ONE meeting in April) |
| May | 3 | Regular Board Meeting |
| | 17 | Regular Board Meeting |
| June | 7 | Regular Board Meeting |
| | 21 | Regular Board Meeting |
| July | | District Dark – No meeting in July |
| August | 2 | Regular Board Meeting |
| | 23 | Regular Board Meeting |
| September | 6 | Regular Board Meeting |
| | 20 | Regular Board Meeting |
| October | 4 | Regular Board Meeting |
| | 18 | Regular Board Meeting |
| November | 1 | Regular Board Meeting (Note: only ONE meeting in November) |
| December | 6 | Regular Board Meeting – Organizational Meeting of the Board (Note: only ONE meeting in December) |

The meeting schedule shown above is subject to change at any time.

NOTE: Changes are indicated in italics/bold.

Board Approved: 12-7-16

Mission: “Ensure a culturally diverse education for each student in a safe, healthy and supportive environment that prepares students for college and career opportunities.”