

1 2 3 4 5 6 7 8 9

9

1

8

2

7

3

6

4

5

5

4

6

3

7

2

8

1

9

SSA

SUMMER

MATH PACKET

RISING

THIRD GRADE

NAME _____

Name _____

Summer Math Packet

Section A Multiple-Choice Questions

1 How many  are there?

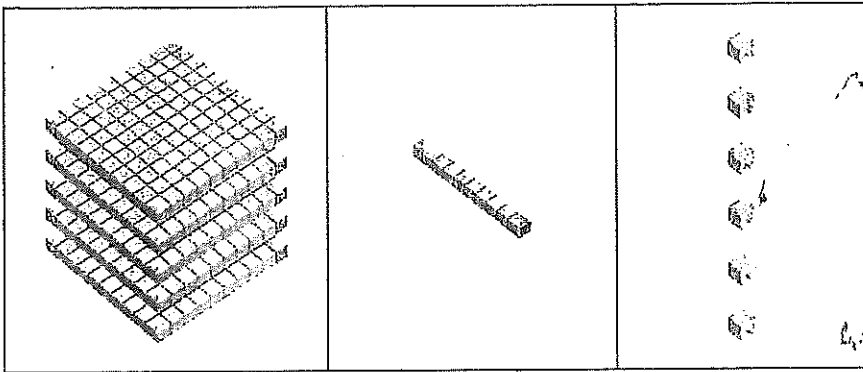

- (A) 165
- (B) 515
- (C) 516
- (D) 561

2 What is the value of the digit 6 in 768?

- (A) 6
- (B) 60
- (C) 66
- (D) 600

- 3 Add.
What is the missing number?

$$285 + 120 = \underline{\hspace{2cm}}$$

$$\begin{array}{r} 285 \\ + 120 \\ \hline \end{array}$$

?

- (A) 505
(B) 405
(C) 400
(D) 305
- 4 Which of the following does **not** make a number pattern with these numbers?

415	435	425
-----	-----	-----

- (A) 395, 405
(B) 405, 445
(C) 420, 440
(D) 420, 430

- 5 Add.
What is the missing number?

$$63 + 45 + 25 = \underline{\hspace{2cm}}$$

$$\begin{array}{r} 63 \\ 45 \\ + 25 \\ \hline \end{array}$$

?

- (A) 68
(B) 128
(C) 123
(D) 133
- 6 What is the missing number?

$$\underline{\hspace{2cm}} - 147 = 376$$

$$\begin{array}{r} \boxed{?} \\ - 147 \\ \hline 376 \end{array}$$

- (A) 229
(B) 413
(C) 423
(D) 523

7 Which number has 2 hundreds 10 tens and 0 ones?

- (A) 21
- (B) 210
- (C) 300
- (D) 310

8 What are the values of A and of B?

$$\begin{array}{r} 3 \ 5 \ 8 \\ + 1 \ \boxed{A} \ 4 \\ \hline \boxed{B} \ 3 \ 2 \end{array}$$

- (A) $A = 2, B = 4$
- (B) $A = 7, B = 4$
- (C) $A = 7, B = 5$
- (D) $A = 8, B = 5$

9 Which of these shows 864 in expanded form?

- (A) $400 + 60 + 8$
- (B) $600 + 80 + 4$
- (C) $800 + 40 + 6$
- (D) $800 + 60 + 4$

10 Which of these needs regrouping to solve?

(A)
$$\begin{array}{r} 819 \\ - 512 \\ \hline \end{array}$$

(B)
$$\begin{array}{r} 754 \\ - 343 \\ \hline \end{array}$$

(C)
$$\begin{array}{r} 600 \\ - 198 \\ \hline \end{array}$$

(D)
$$\begin{array}{r} 566 \\ - 436 \\ \hline \end{array}$$

Section B Short Answer Questions

(3 × 2 = 6 points)

- 11 Subtract mentally.
Write the answer in each blank.

a $13 - 9 =$ _____

b $462 - 10 =$ _____

- 12 Anna is making a number with the least value with these three digits.

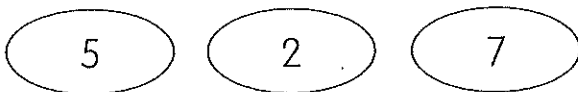

Comparing the digits, 2 is the least.
So, I placed 2 in the ones place which
has the least value.



The least number is 572.

Anna

Why is Anna not correct?

Then, write the least number that Anna can make.

The least number is _____.

- 13 Amanda is solving the following problem:

$$13 + 15 + 85 + 87 = \underline{\hspace{2cm}}$$

She says that solving the problem above is the same as solving doubles 100.

Explain why Amanda is correct.

Then, solve $13 + 15 + 85 + 87$.

Show your work and write your answer in the blank below.

$$13 + 15 + 85 + 87 = \underline{\hspace{2cm}}$$



Assessment Guide

Cumulative Review 2

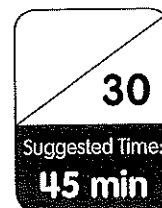

Section A Multiple-Choice Questions

(10 × 2 = 20 points)

- 1 There are 95 students at a book fair.
 34 of them are first graders.
 The rest are second graders.
 How many second graders are at the book fair?

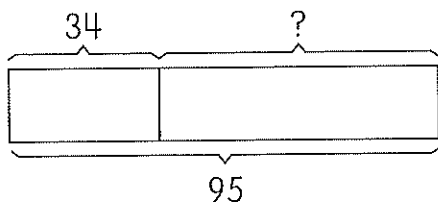

- (A) 31
- (B) 61
- (C) 62
- (D) 129

- 2 Lucy has 48 marbles.
Her brother gives her 34 marbles.
How many marbles does she have in all?

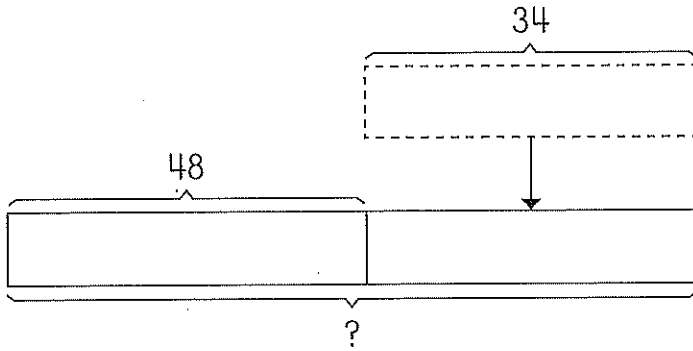

- (A) 92
(B) 82
(C) 74
(D) 14
- 3 David has 117 cards.
Hannah has 226 more cards than David.
How many cards does Hannah have?

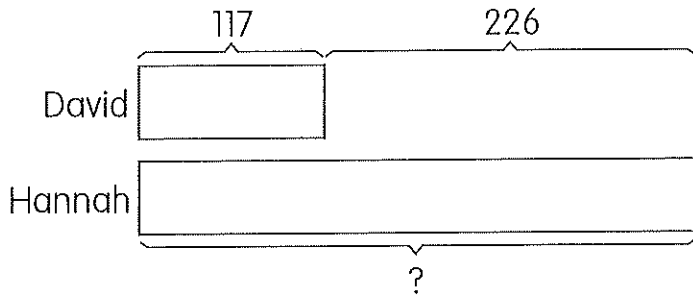

- (A) 109
(B) 111
(C) 342
(D) 343

- 4 The length of the pencil is about 10 centimeters long.
What is the length of the paintbrush?



- (A) about 10 centimeters
(B) about 20 centimeters
(C) about 30 centimeters
(D) about 40 centimeters
- 5 Julia wants to measure the length around a basketball.
Which of these should she use?

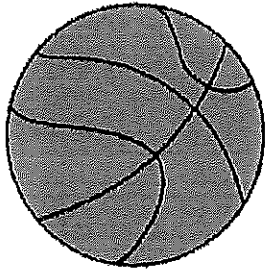

- (A) centimeter tape
(B) foot ruler
(C) inch ruler
(D) meter stick

- 6 The corn plant is 62 inches tall.
The tomato plant is 37 inches tall.
How much taller is the corn plant than the tomato plant?

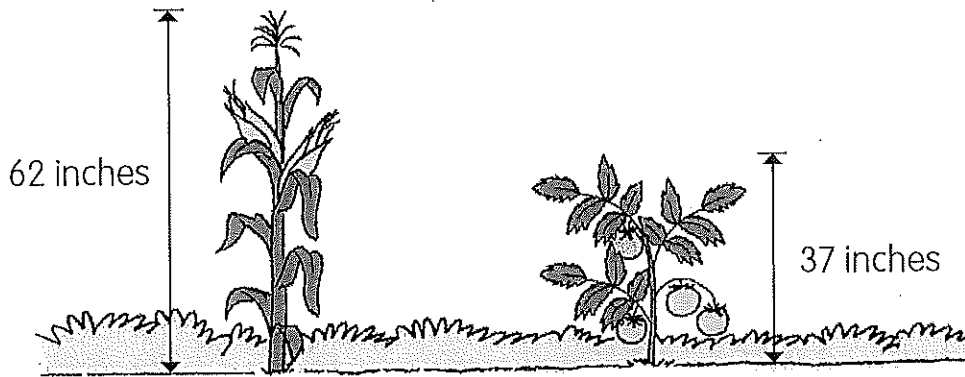

- (A) 25 inches
(B) 26 inches
(C) 35 inches
(D) 99 inches
- 7 Andre is a Grade 2 boy.
He is about 4 _____ tall
- (A) centimeters
(B) meters
(C) inches
(D) feet

- 12 Ms. Lopez has some cookies.
She bakes another 36 cookies.
Then, she gives 55 cookies to her friends.
She has 19 cookies left.
How many cookies does Ms. Lopez have at first?
Draw bar models to help you solve the problem.

Show your work and write your answer in the blank below.

Ms. Lopez has _____ cookies at first.



Assessment Guide

Cumulative Review 3

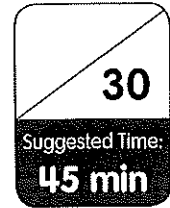

Section A Multiple-Choice Questions

(10 × 2 = 20 points)

- 1 The picture graph shows the favorite camping activities of 15 scouts.

Our Favorite Camping Activities

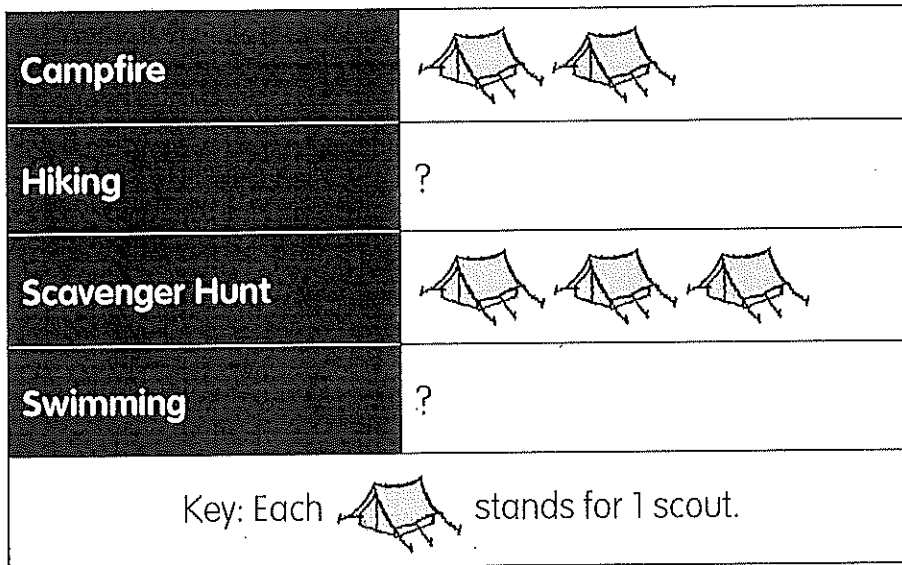

The same number of scouts like hiking or swimming.
How many scouts like swimming?

- (A) 2
- (B) 3
- (C) 5
- (D) 10

- 2 The bar graph shows the favorite subjects of some students.

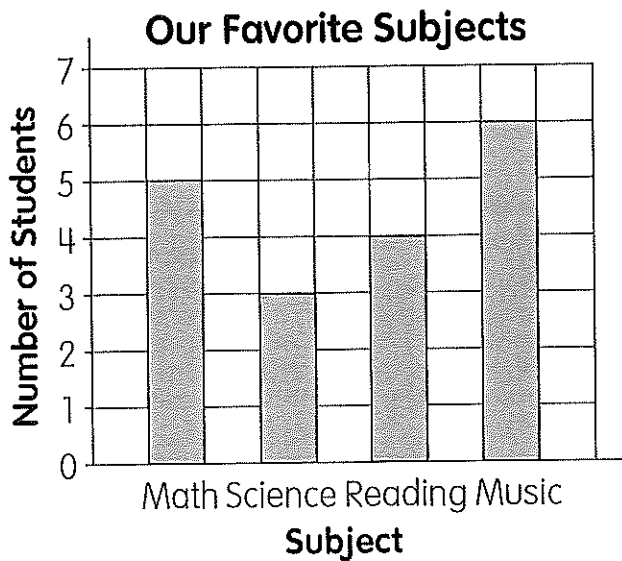

How many more students like Math than Science?

- (A) 5 (B) 4
(C) 3 (D) 2

- 3 The line plot shows the length of some pieces of ribbon in inches.

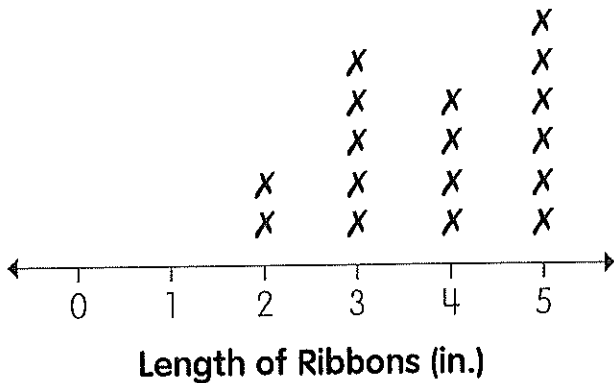

How many pieces of ribbon are more than 4 inches long?

- (A) 4 (B) 6
(C) 7 (D) 10

- 4 Look at the picture.
Which number sentence matches the picture?

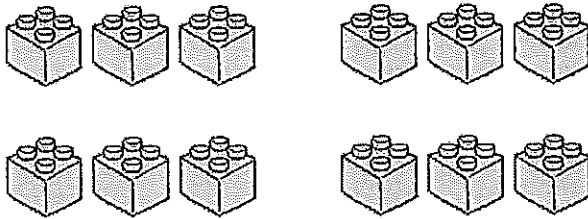

- (A) $2 \times 5 = 10$ (B) $3 \times 5 = 15$
(C) $4 \times 2 = 8$ (D) $4 \times 3 = 12$

- 5 Emily has 9 toy tricycles.
She uses 3 toy wheels to build one toy tricycle.
How many toy wheels are there?

- (A) 3 (B) 6
(C) 12 (D) 27

- 6 Matthew gives 16 stickers equally to 4 friends.
How many stickers does each friend get?

- (A) 4 (B) 5
(C) 6 (D) 20

- 7 Mr. Lewis divides 30 students into groups of 10.
How many groups are there in all?

- (A) 2 (B) 3
(C) 20 (D) 40

- 8 Ms. Adams plants some flowers in 6 rows of 5.
Which does **not** show the way to find the total number of flowers?

- (A) 6×5
- (B) $6 + 6 + 6 + 6 + 6 + 6$
- (C) $5 + 5 + 5 + 5 + 5 + 5$
- (D) 5×6

- 9 Look at the picture.
Which number sentence about the picture is **false**?

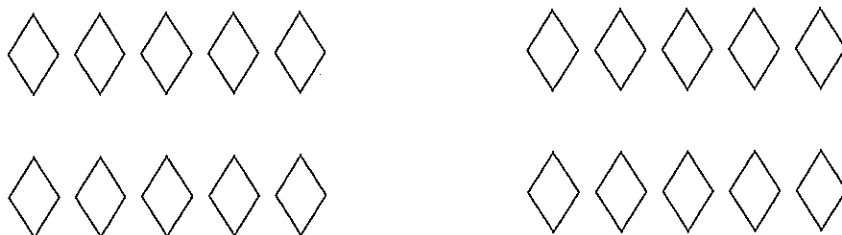

- (A) $4 \times 5 = 20$
- (B) $5 \times 4 = 20$
- (C) $16 \div 4 = 4$
- (D) $20 \div 4 = 5$

- 10 Find the missing number.

$$40 \div 4 = \underline{\hspace{2cm}} \times 5$$

- (A) 50
- (B) 15
- (C) 5
- (D) 2

Section B Short Answer Questions

(3 × 2 = 6 points)

- 11 Ms. Jones counted the number of books some students read in a week.

She recorded the data in a tally chart.

Name of Student	Tally	Number
Alexa		4
Tyler		3
Lily	/	5
Wyatt		4

- a Use the data in the tally chart to draw the bar graph.

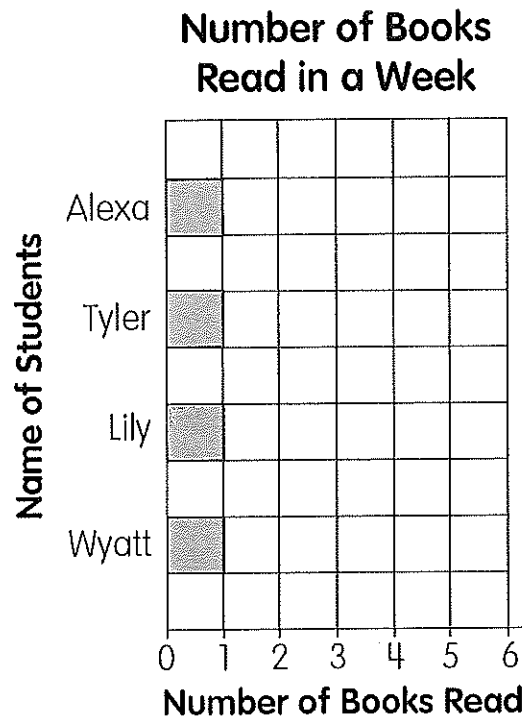

- b _____ and _____ read the same number of books.

- 12 There are 9 sacks of rice.
Each sack of rice weighs 4 kilograms.
Axel wants to use a trolley to move these sacks.
The trolley can only carry a total of 35 kilograms.
Will Axel be able to move all these sacks all at one go?

Show your work.
Then, circle the correct answer.

Axel will be able / not be able to move these sacks all at one go.

- 13 Ang has 40 potatoes.
He wants to group them into bags of 4.
Jess has 45 potatoes.
She wants to group them into bags of 5.

Jess has more potatoes.
So, she will have more
bags than Ang.



Stella

Is Stella correct?
Why do you think so?

Show your work in the space below.
Then, circle the correct answer.

Stella is correct / incorrect .

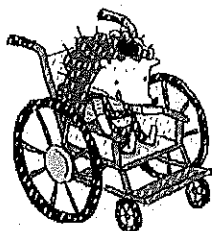

Assessment Guide

Cumulative Review 4

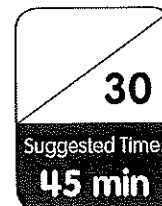

Section A Multiple-Choice Questions

(10 × 2 = 20 points)

- 1 The clock shows the time Kate goes to soccer practice in the afternoon.
What time does Kate go to soccer practice?

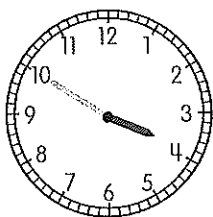

- (A) 3:50 P.M.
 - (B) 4:50 P.M.
 - (C) 10:20 A.M.
 - (D) 10:20 P.M.
- 2 Which activity would you most likely be doing at 10:00 P.M.?
- (A) riding a bike
 - (B) playing with friends at school
 - (C) sleeping
 - (D) eating breakfast

- 3 Count the bill and coins.
What is the amount of money?



- (A) \$1.35
(B) \$1.53
(C) \$5.53
(D) \$5.70
- 4 Ethan wants to buy a carton of juice for \$1.00.
Which of these can he use to buy the carton of juice?
- (A) 3 quarters
(B) 10 dimes
(C) 10 nickels
(D) 90 pennies

5 Look at the coins.



Which of these shows the same amount of money?

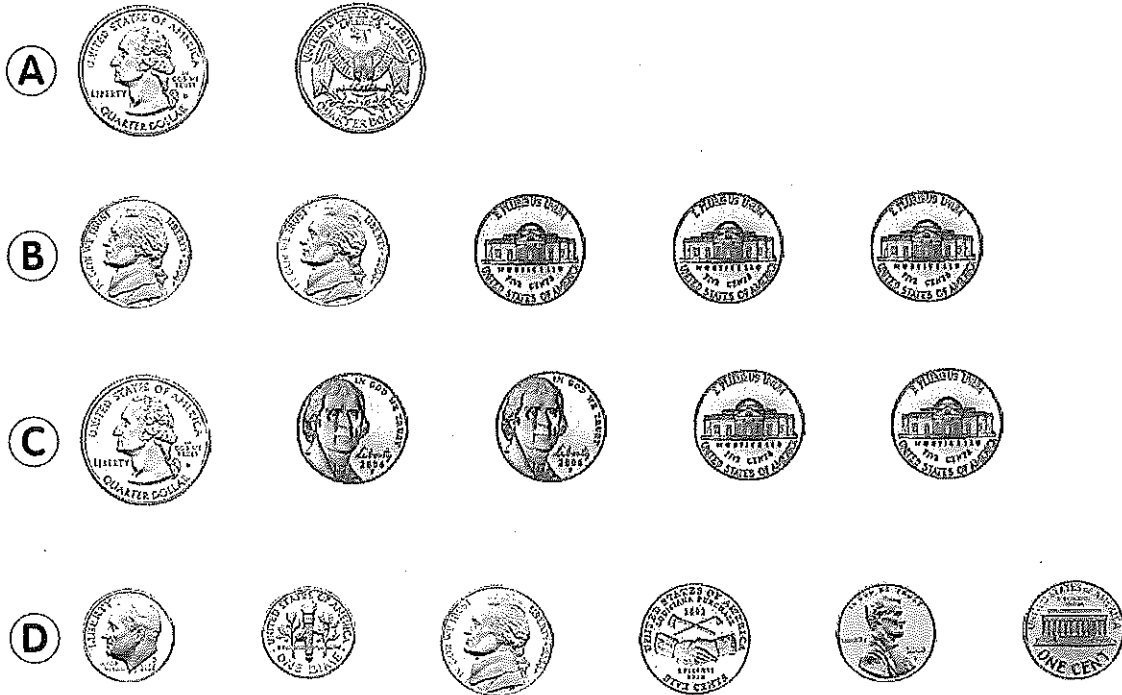

6 Which solid has 6 equal faces?

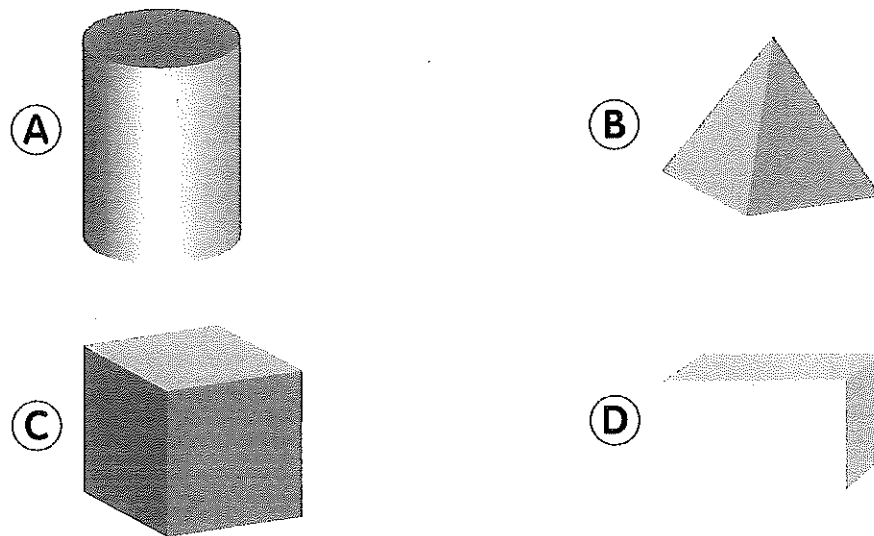

7 Which of the following does not describe a pentagon?

- (A) A pentagon has 5 sides.
- (B) A pentagon can be cut into 5 equal triangles.
- (C) A pentagon has no curved lines.
- (D) A pentagon is a quadrilateral.

8 Which solid can you stack, slide, and roll?

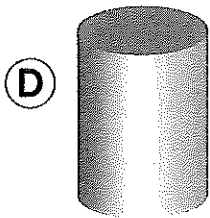
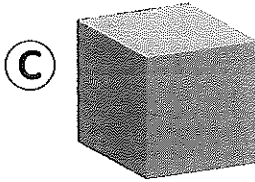
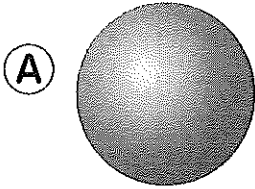

- 9 Look at the picture.
How many circles are there in all?

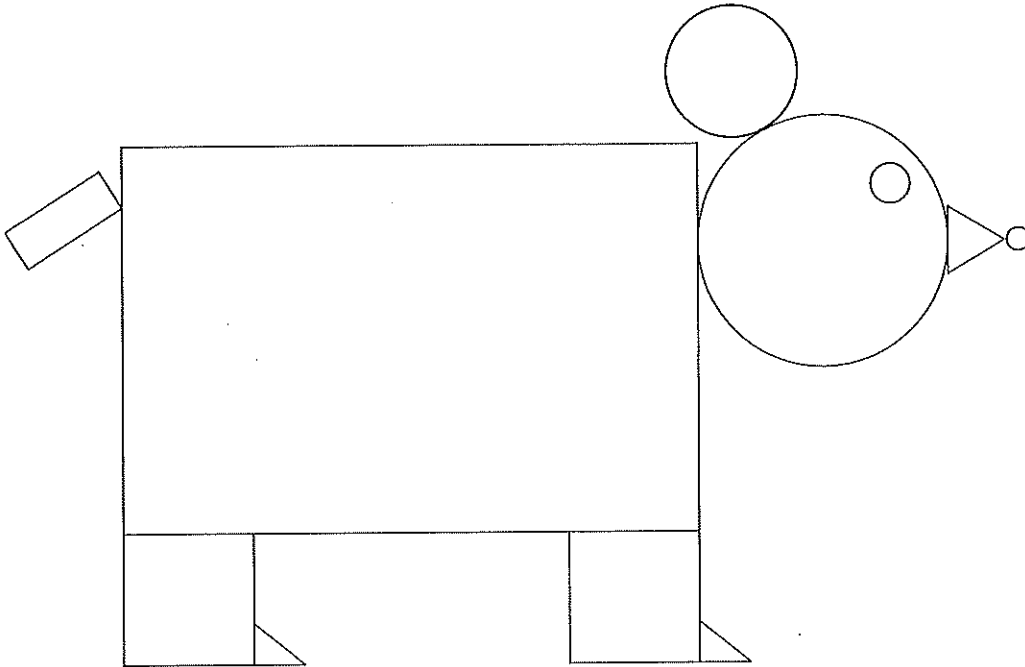

- (A) 4
- (B) 3
- (C) 2
- (D) 1

10 Which flat shape is divided into thirds?

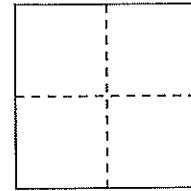
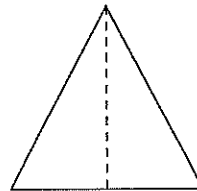
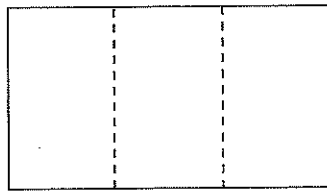
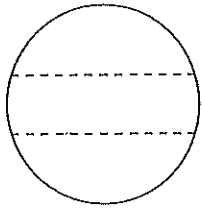

- (A) circle
- (B) rectangle
- (C) triangle
- (D) square

Section B Short Answer Questions

(3 × 2 = 6 points)

- 11 Alan goes to the school store to get some supplies. He has \$1.75.

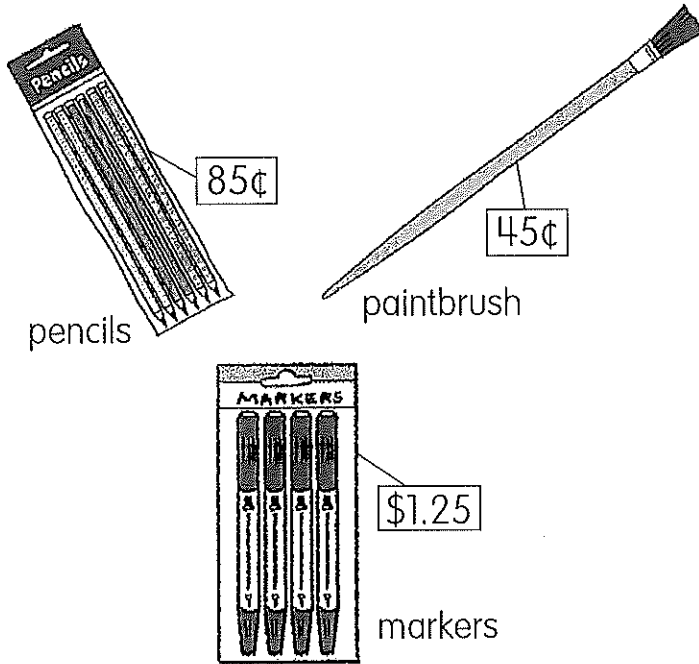

List two things he can buy and how much he will spend.

Show your work and write the answers in the blanks below.

He can buy _____ and _____.

He will spend _____.

- 12 Sofia wants to draw lines to divide a square into fourths. She wants to do so in four different ways. Two of her ways are shown below:

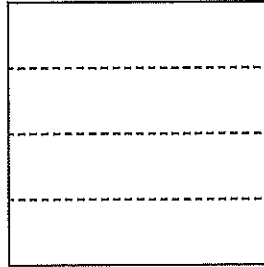
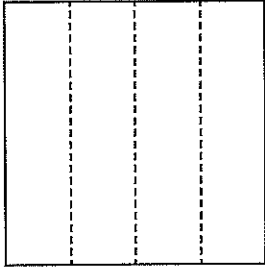

Help Sofia think of the other two ways to divide a square into fourths.

Draw lines to show your work.
Then, color to show one fourth.

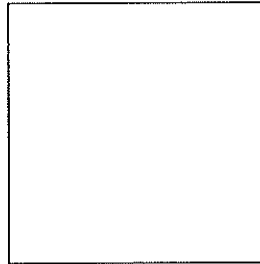
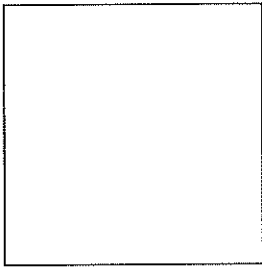

- 13 Luna shows the time seven forty-five.

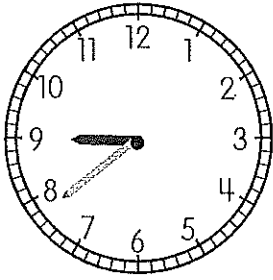

What is Luna's mistake?

Draw the clock hands to show seven forty-five.

