

ROYAL HS - MPR RENOVATION

1402 ROYAL AVENUE,
 SIMI VALLEY CA. 93065

SIMI VALLEY UNIFIED SCHOOL DISTRICT
 875 COCHRAN STREET,
 SIMI VALLEY, CA 93065

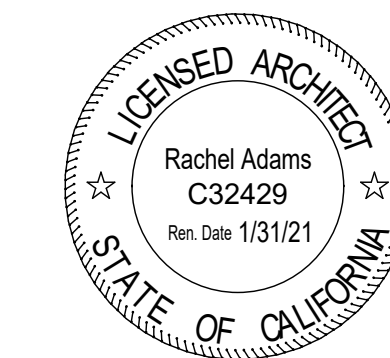

Agency Approval FILE NO. 56-H6

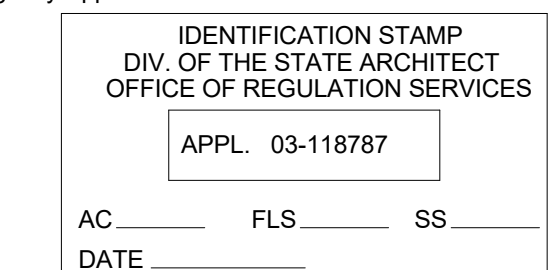

NUMBER	ISSUE	DATE
3	ADD #3	2020/02/24

DATE 10/11/19
 JOB NUMBER 1705-00-02
 SCALE AS NOTED
 DRAWN --
 CHECKED --
 APPROVED --
 KEY PLAN

TITLE WINDOW DETAILS

SHEET

A8.26

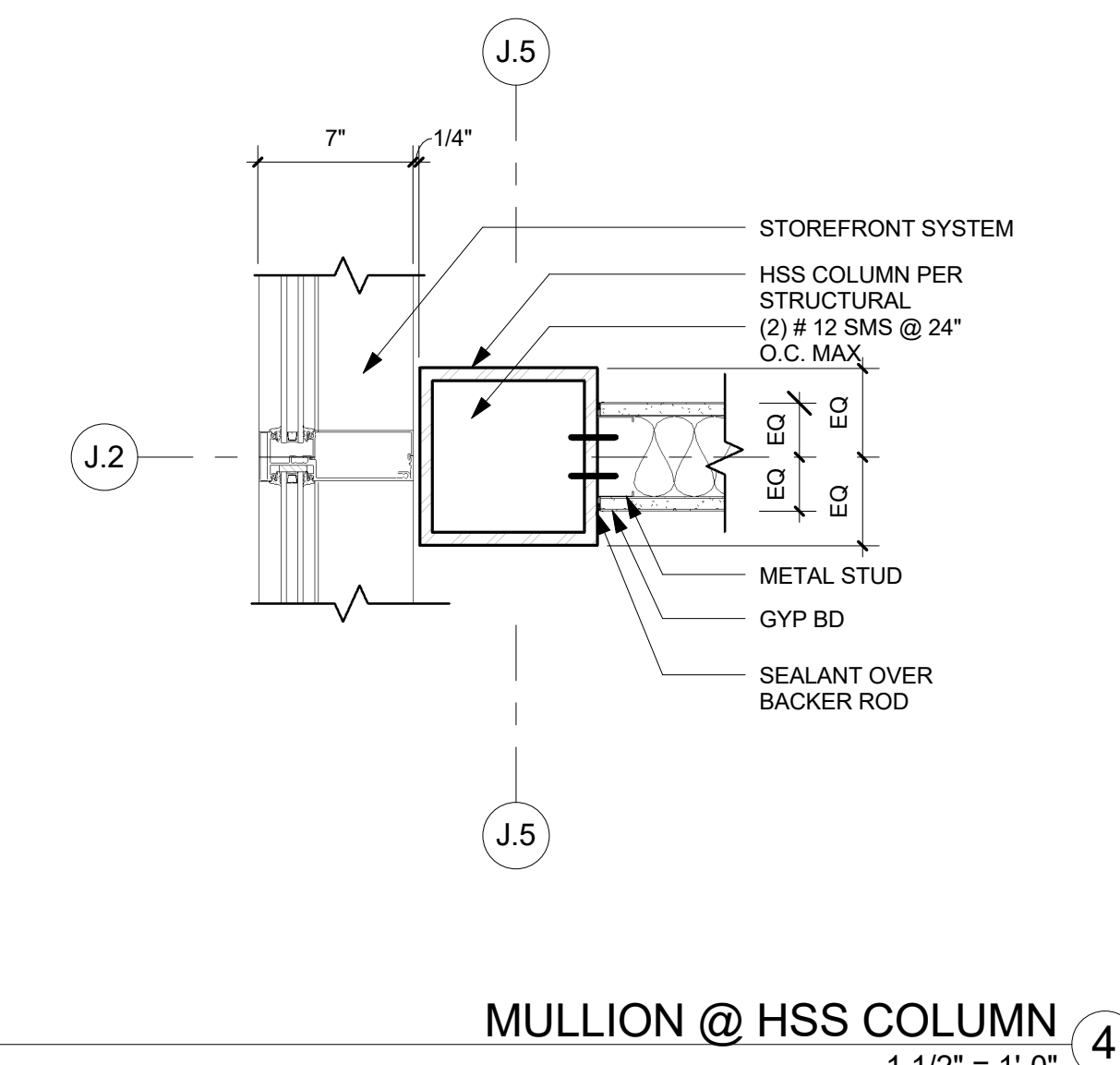

MULLION @ HSS COLUMN 4
 1 1/2" = 1'-0"

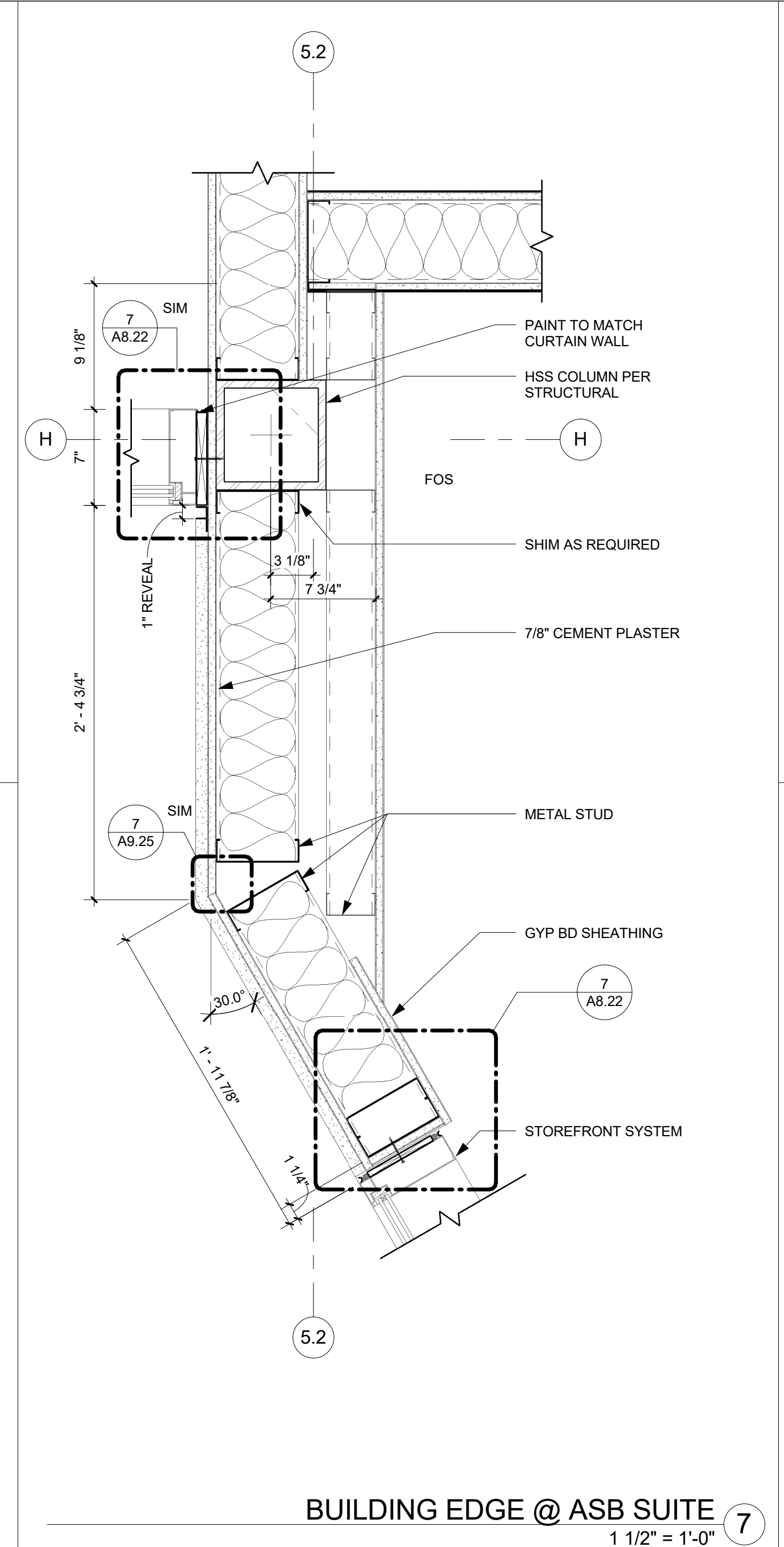

BUILDING EDGE @ ASB SUITE 7
 1 1/2" = 1'-0"

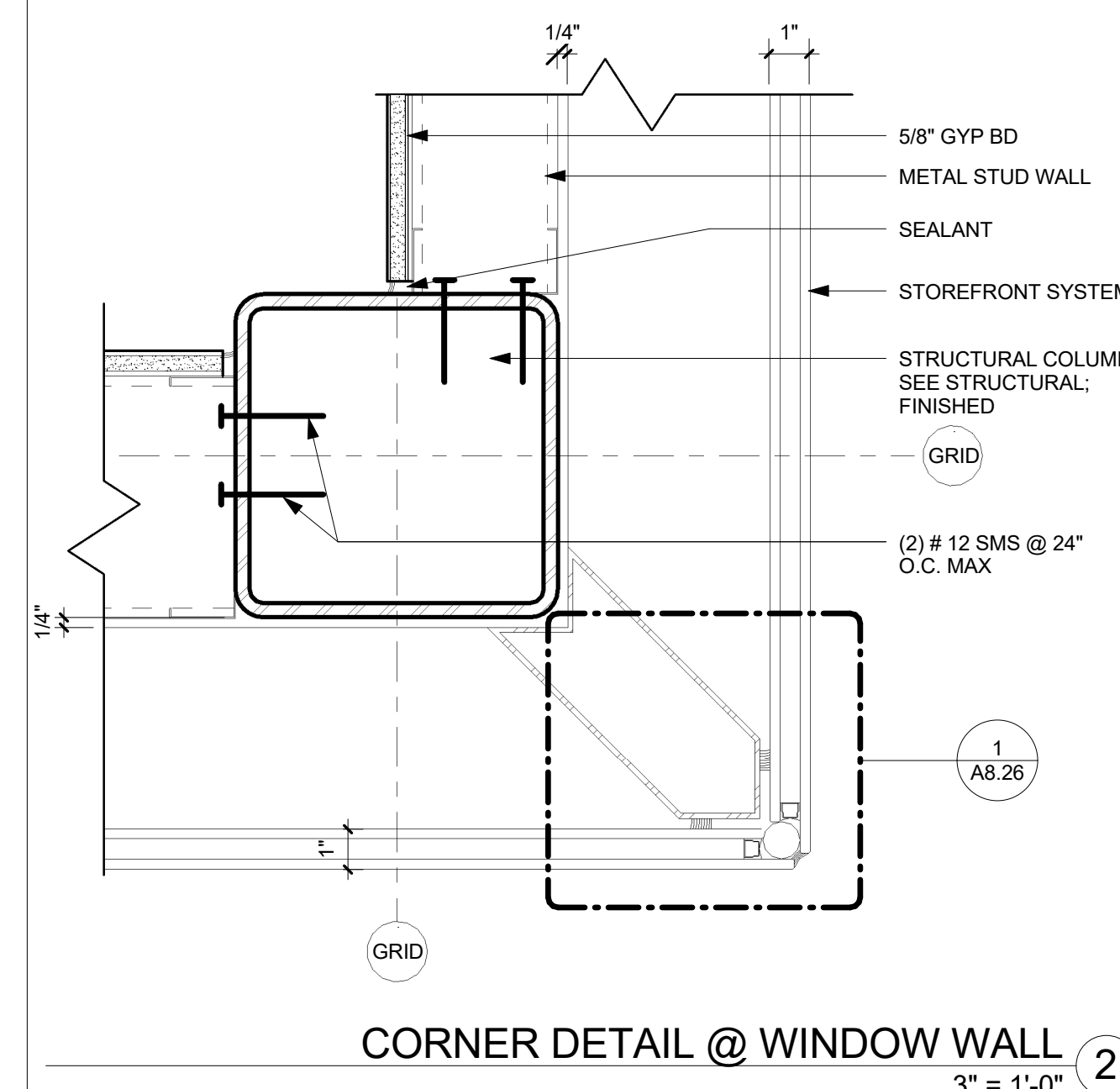

CORNER DETAIL @ WINDOW WALL 2
 3" = 1'-0"

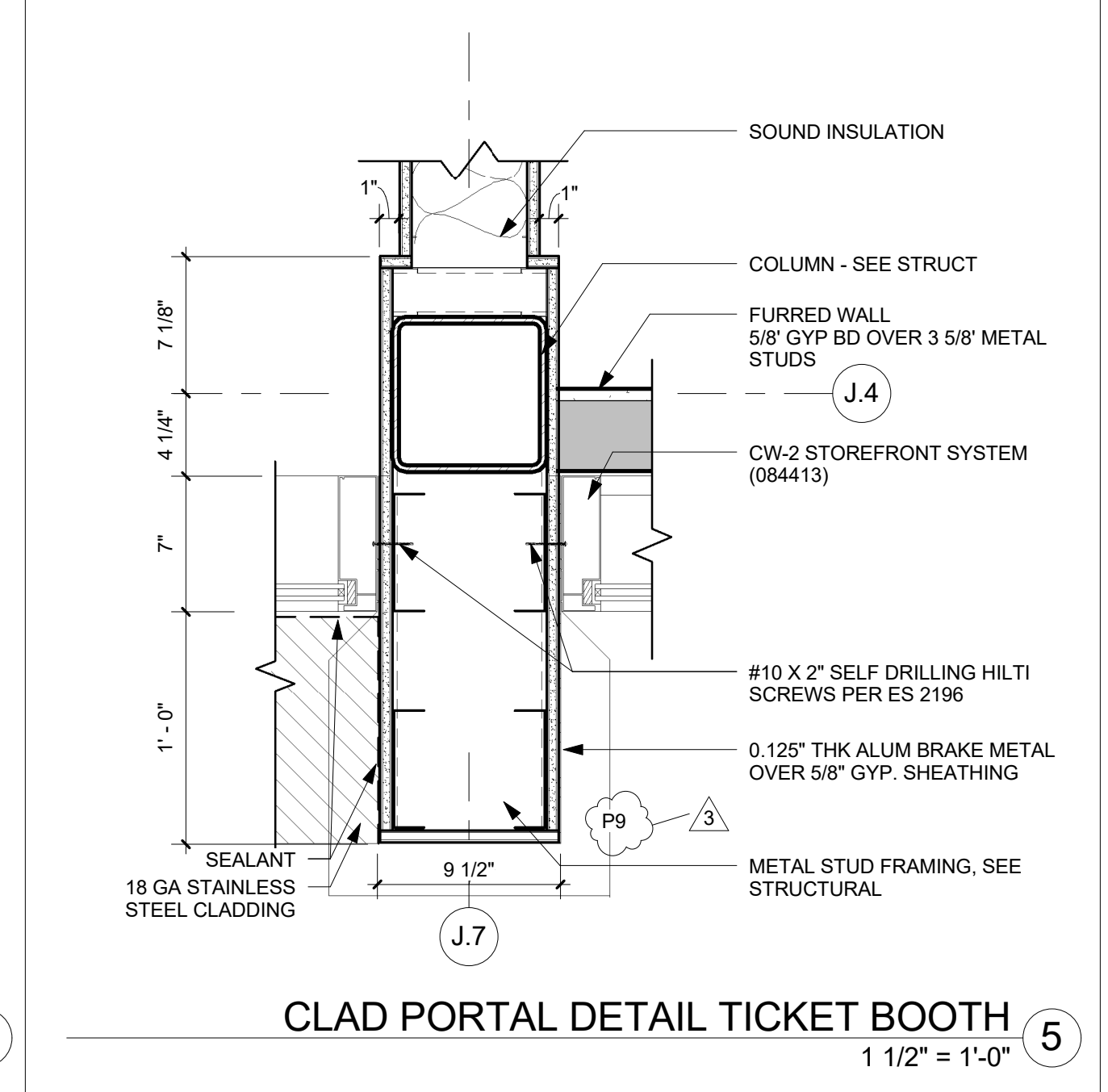

CLAD PORTAL DETAIL TICKET BOOTH 5
 1 1/2" = 1'-0"

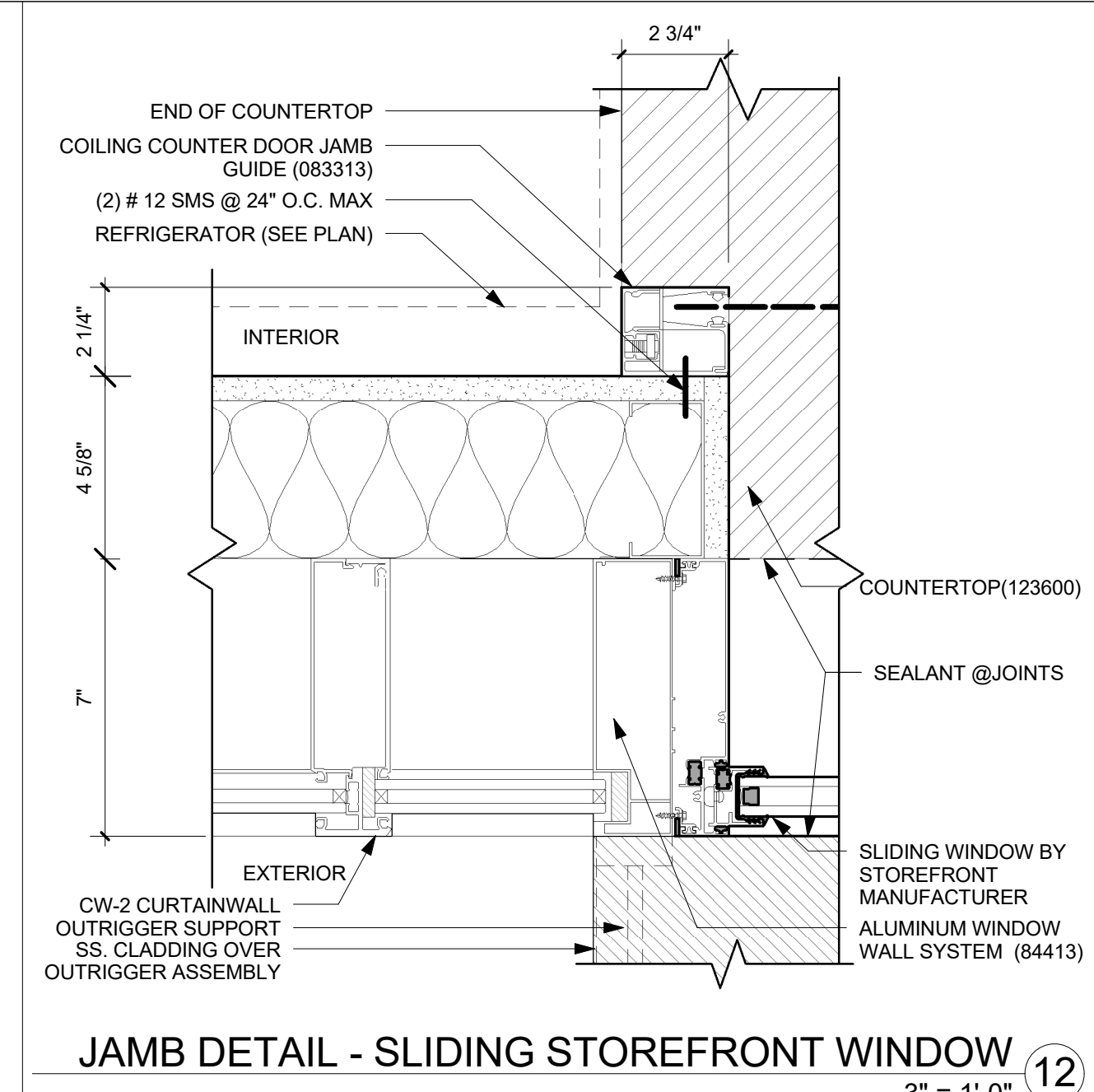

JAMB DETAIL - SLIDING STOREFRONT WINDOW 12
 3" = 1'-0"

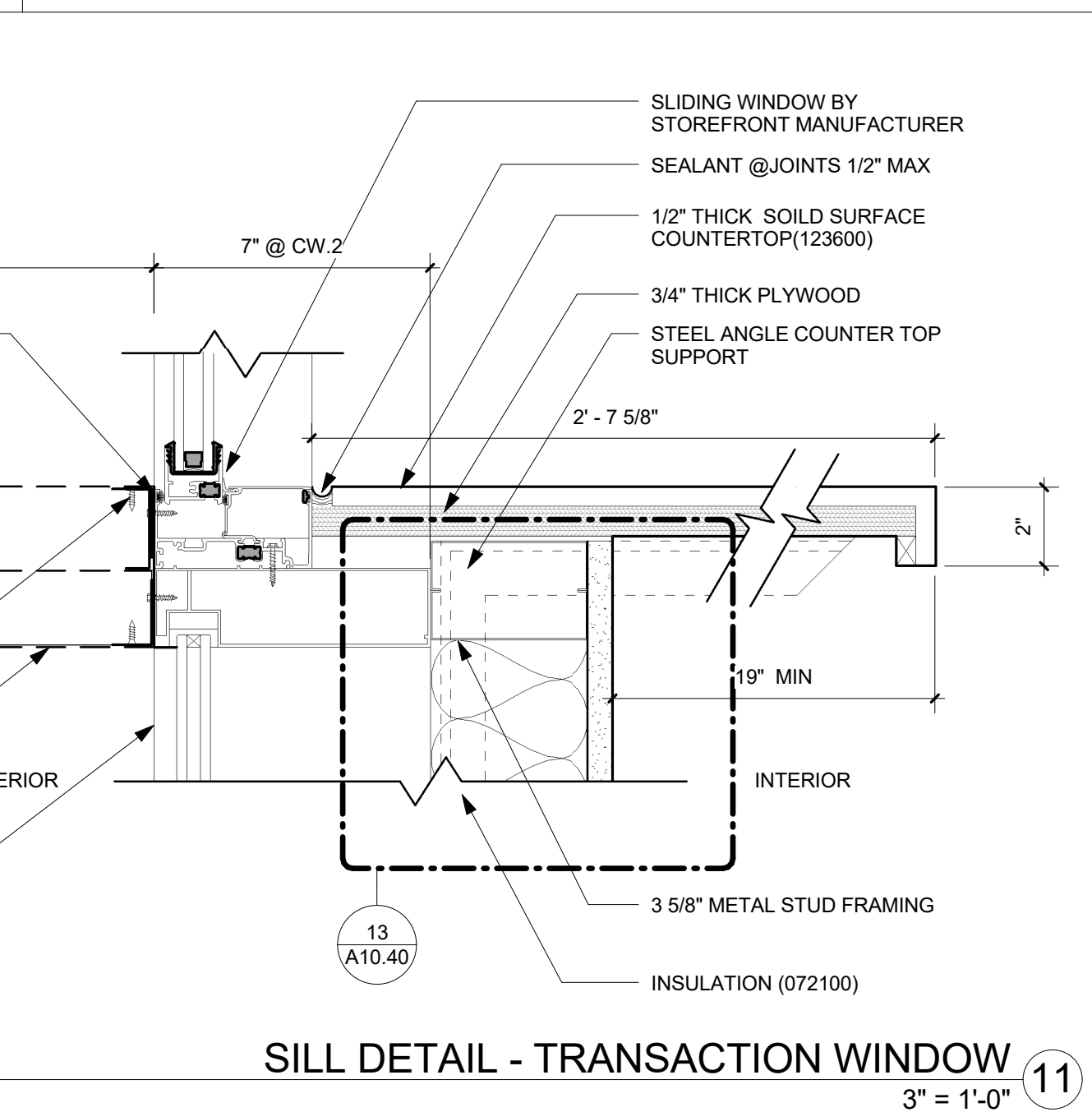

SILL DETAIL - TRANSACTION WINDOW 11
 3" = 1'-0"

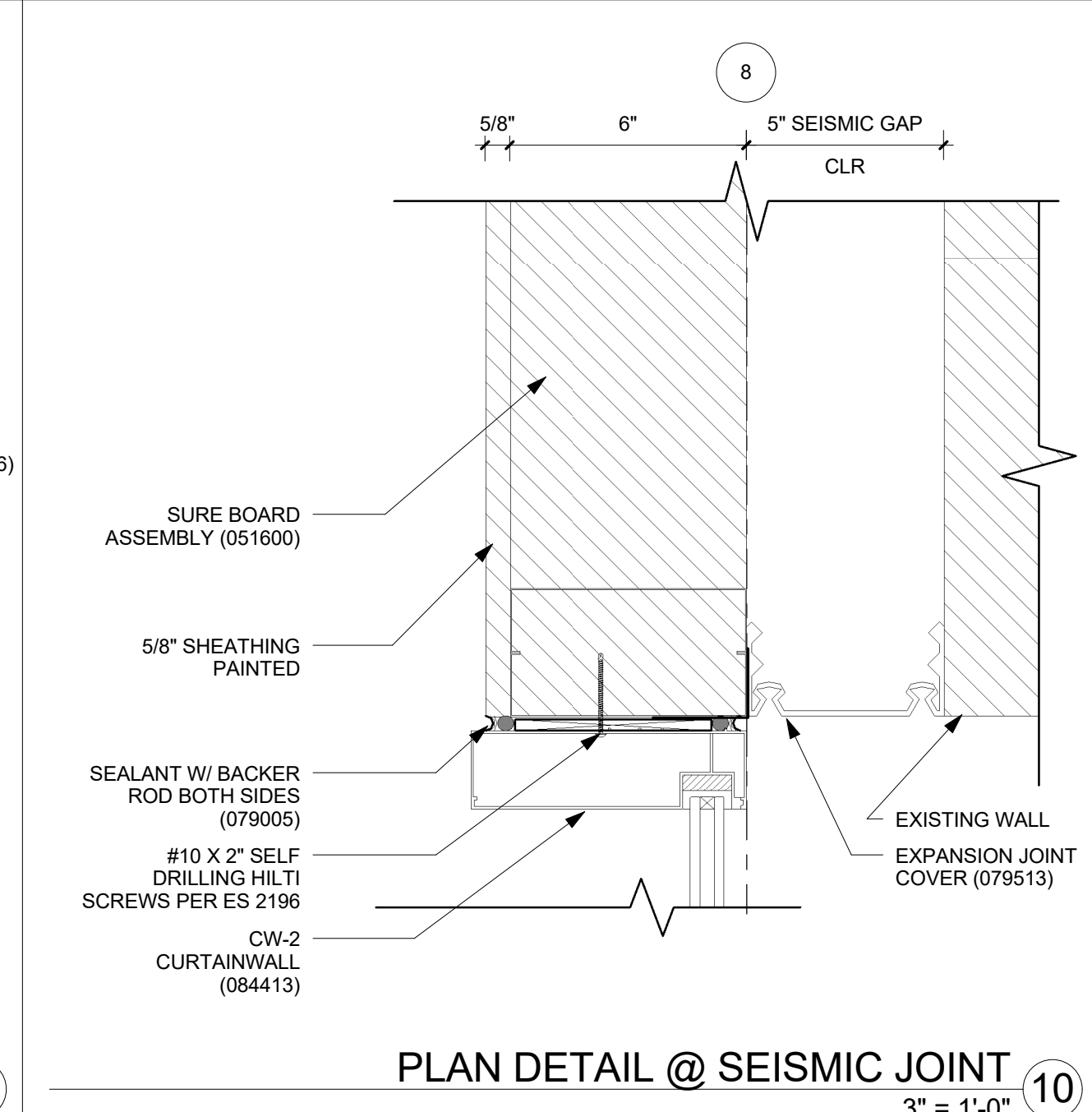

PLAN DETAIL @ SEISMIC JOINT 10
 3" = 1'-0"

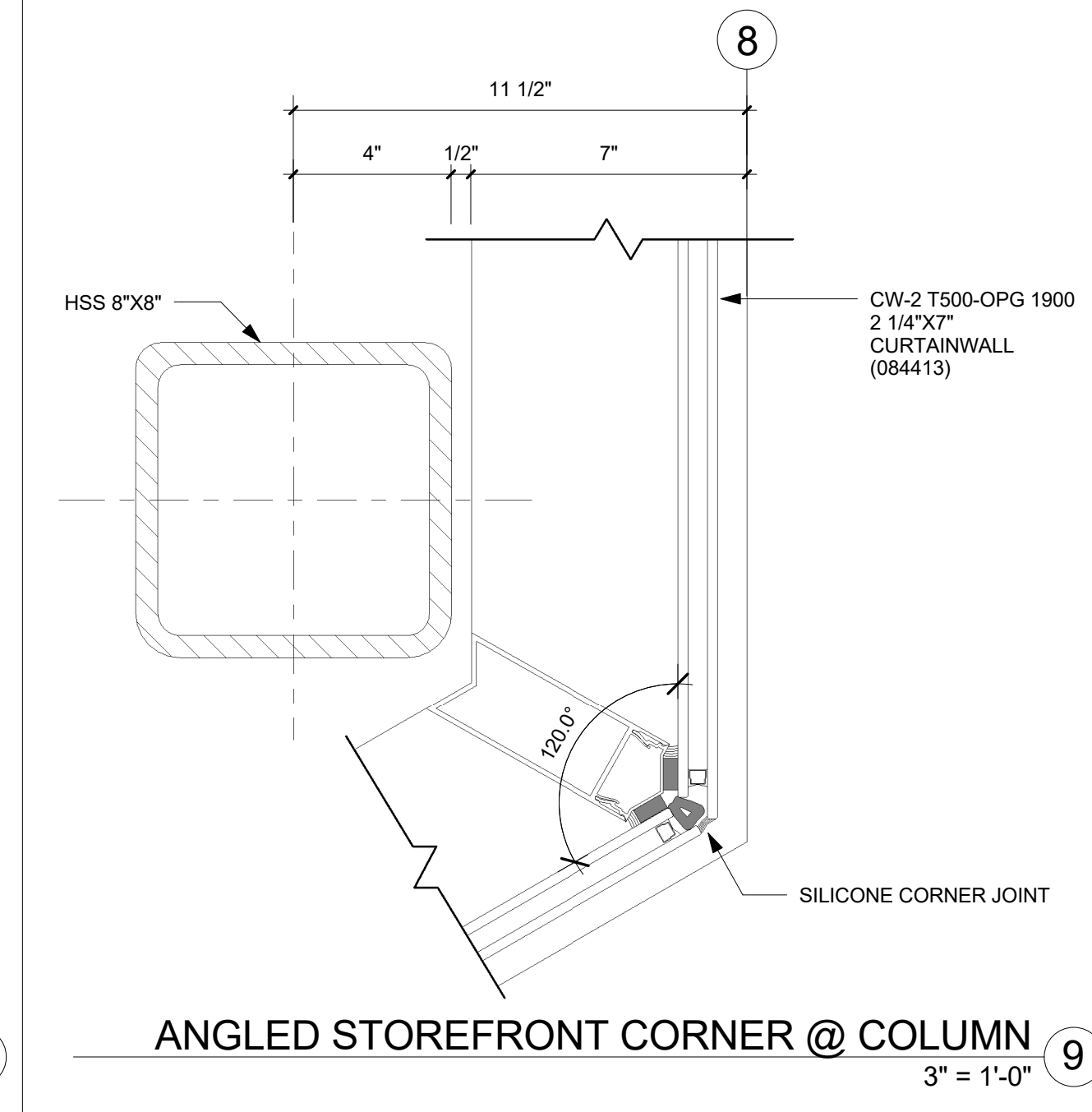

ANGLED STOREFRONT CORNER @ COLUMN 9
 3" = 1'-0"

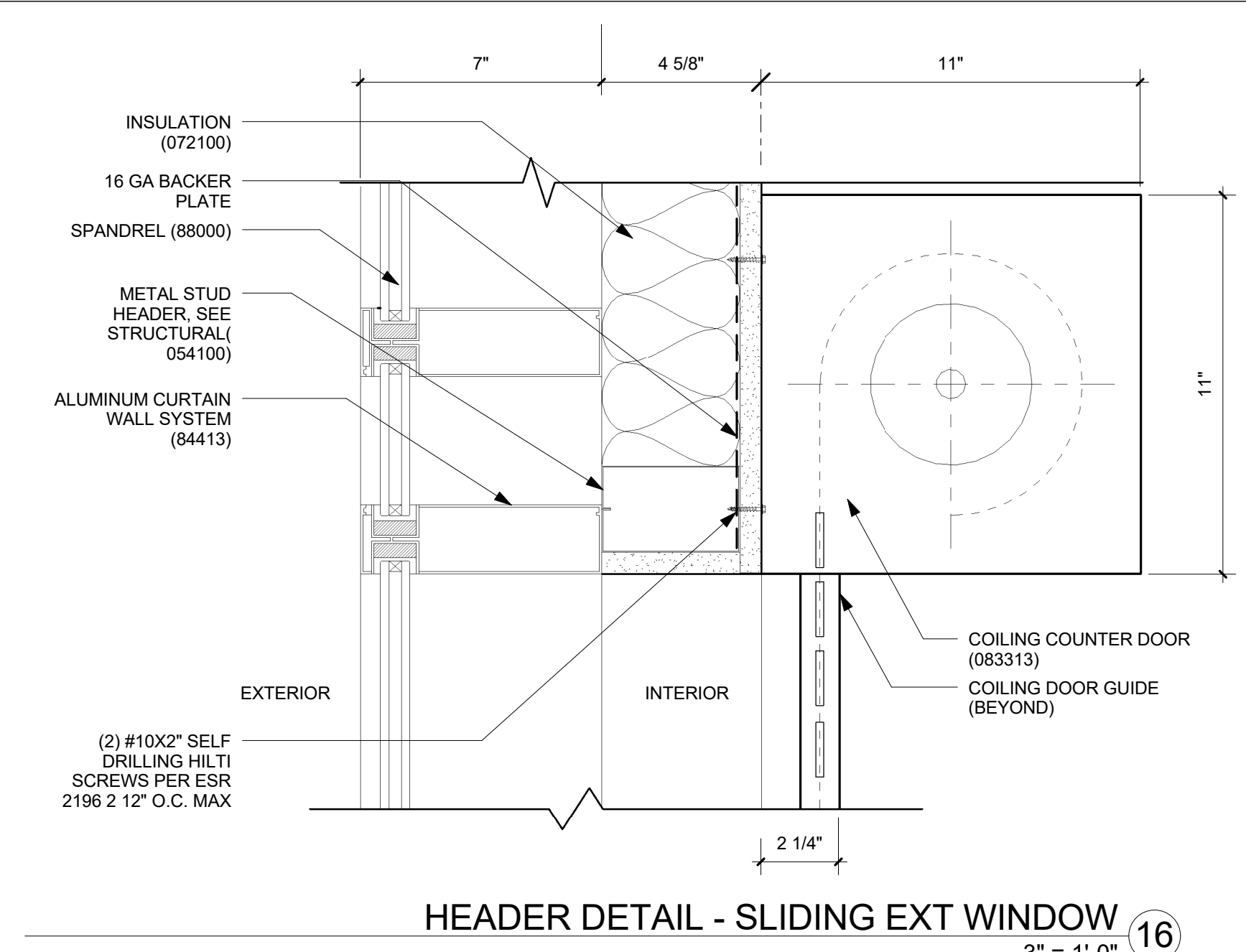

HEADER DETAIL - SLIDING EXT WINDOW 16
 3" = 1'-0"

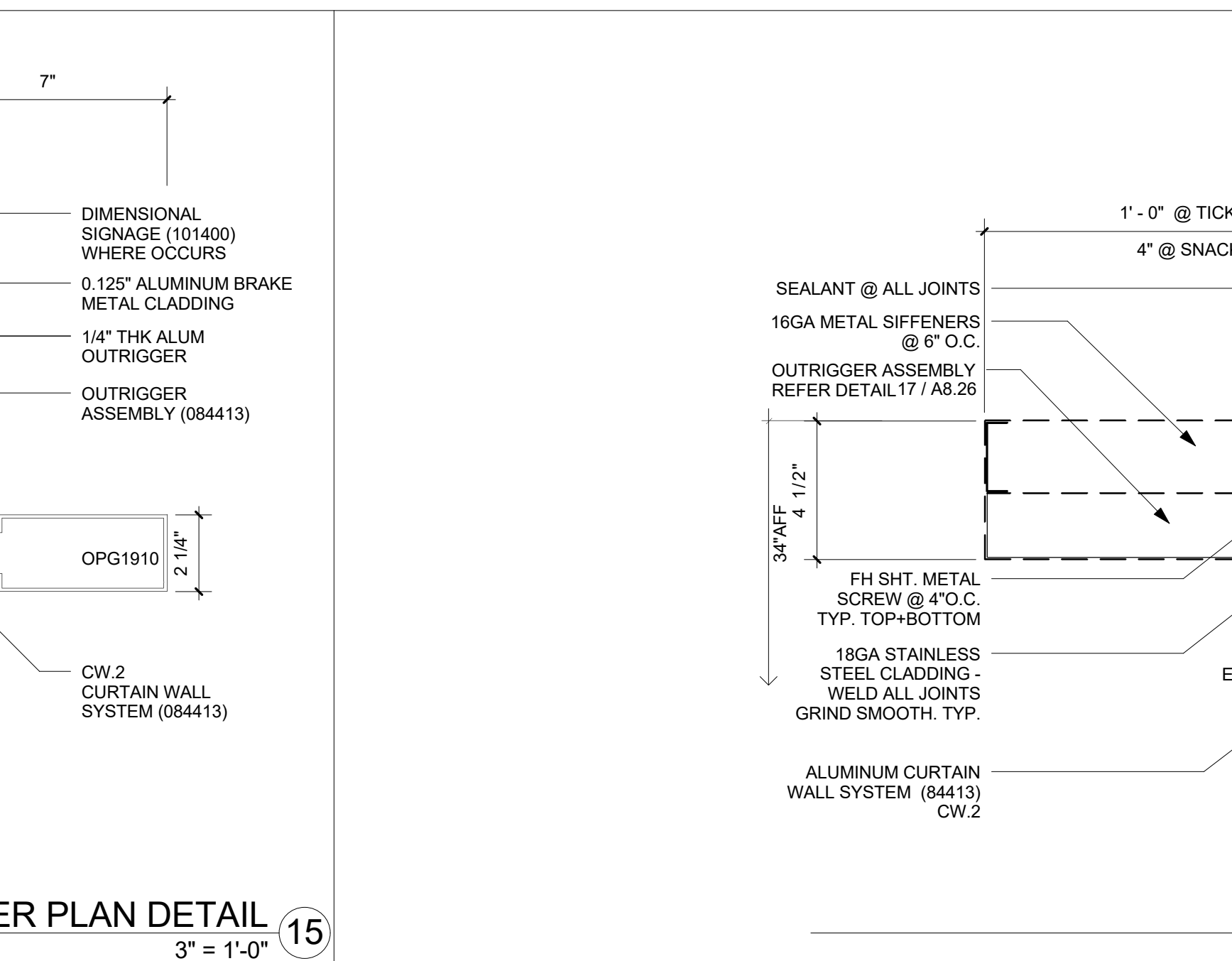

OUTRIGGER PLAN DETAIL 15
 3" = 1'-0"

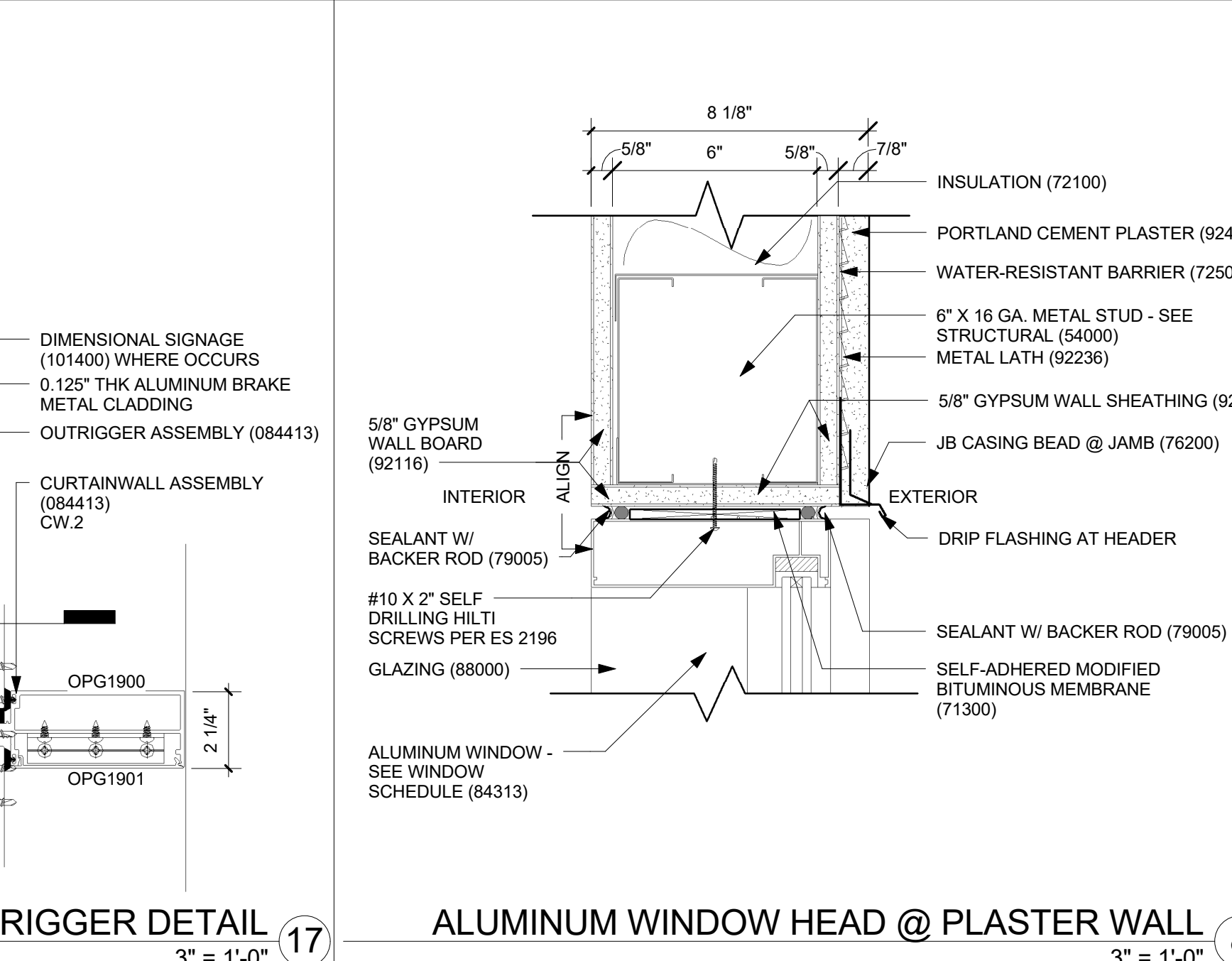

ALUMINUM WINDOW HEAD @ PLASTER WALL 8
 3" = 1'-0"

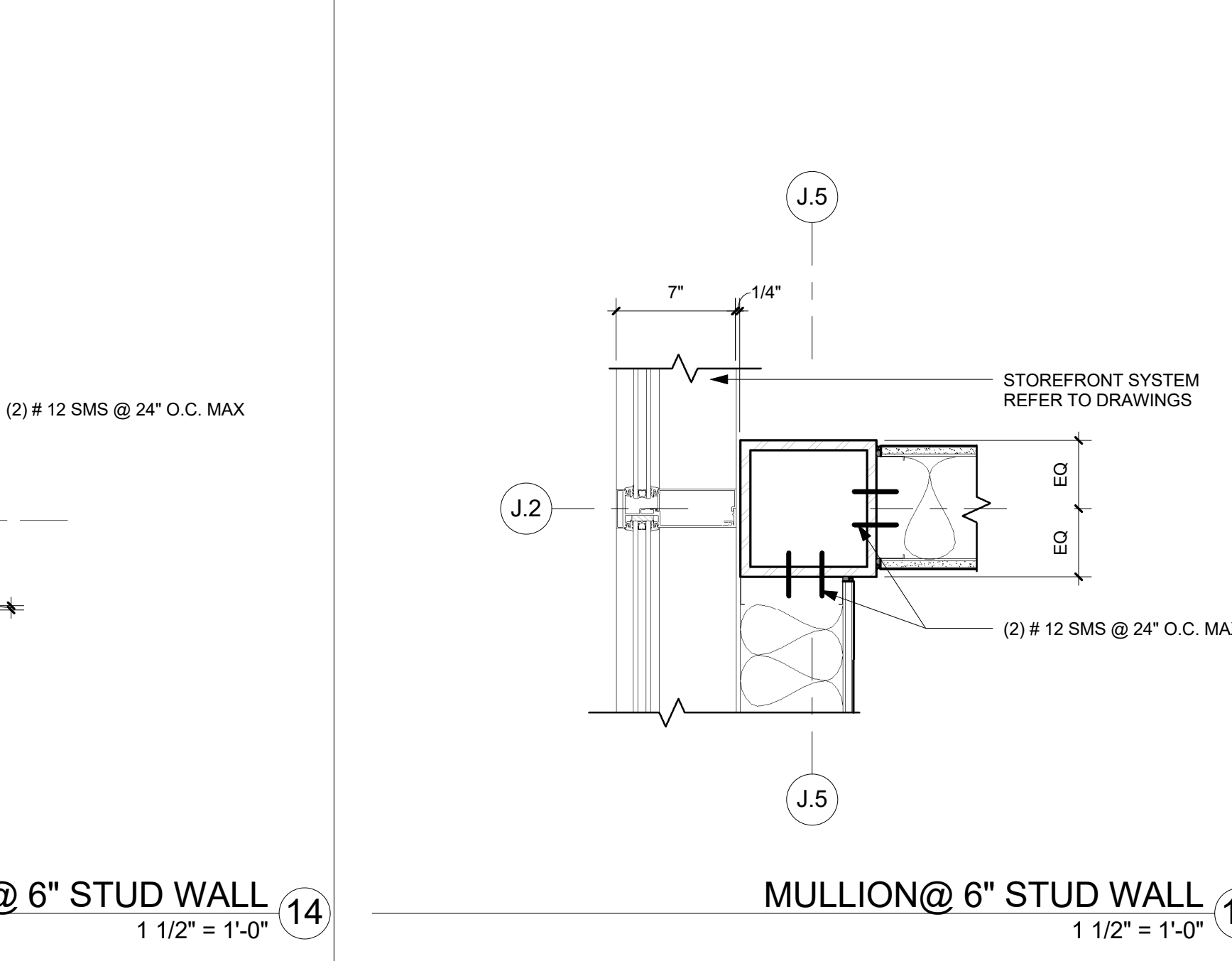

MULLION @ 6" STUD WALL 14
 1 1/2" = 1'-0"

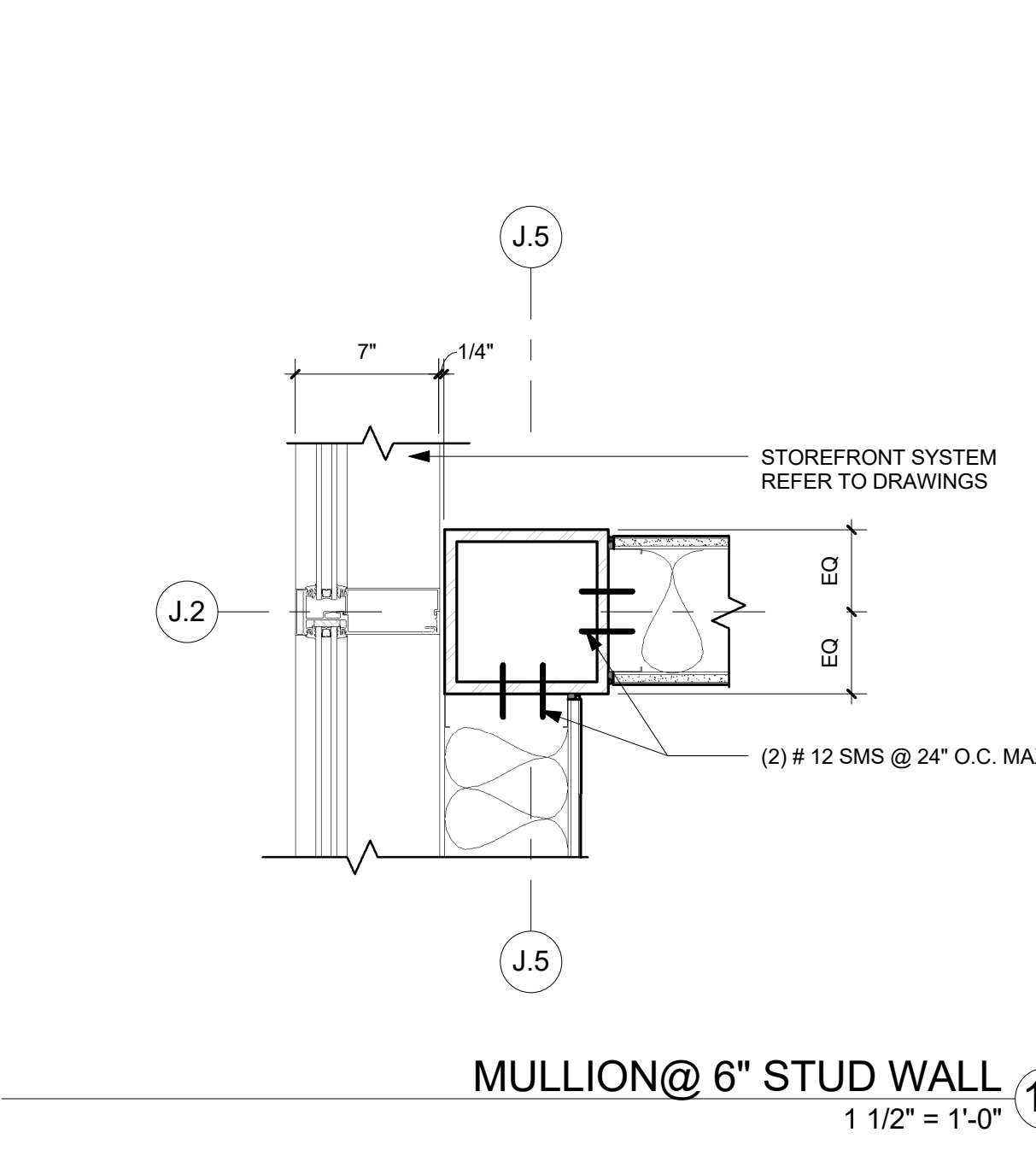

MULLION @ 6" STUD WALL 13
 1 1/2" = 1'-0"

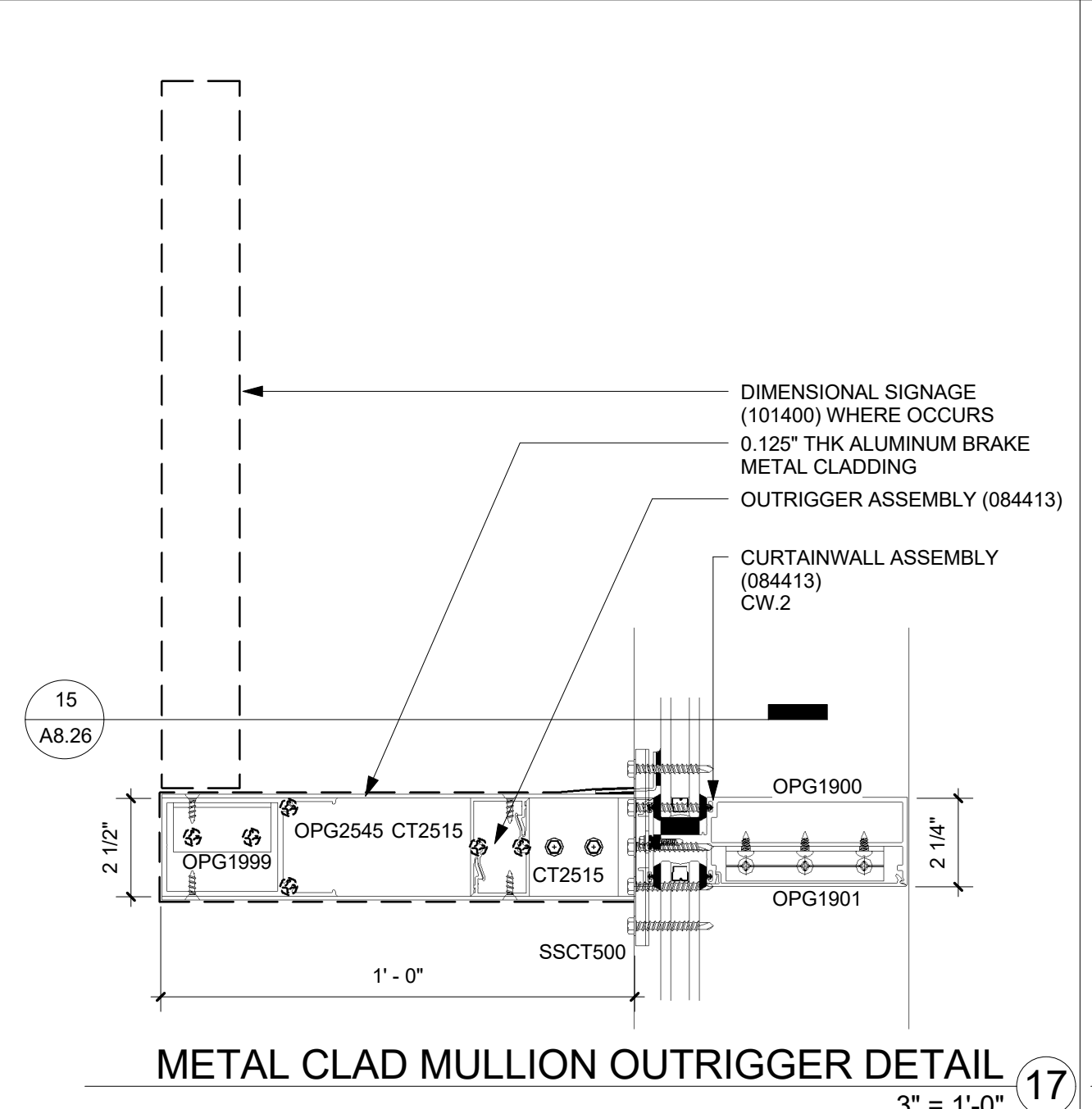
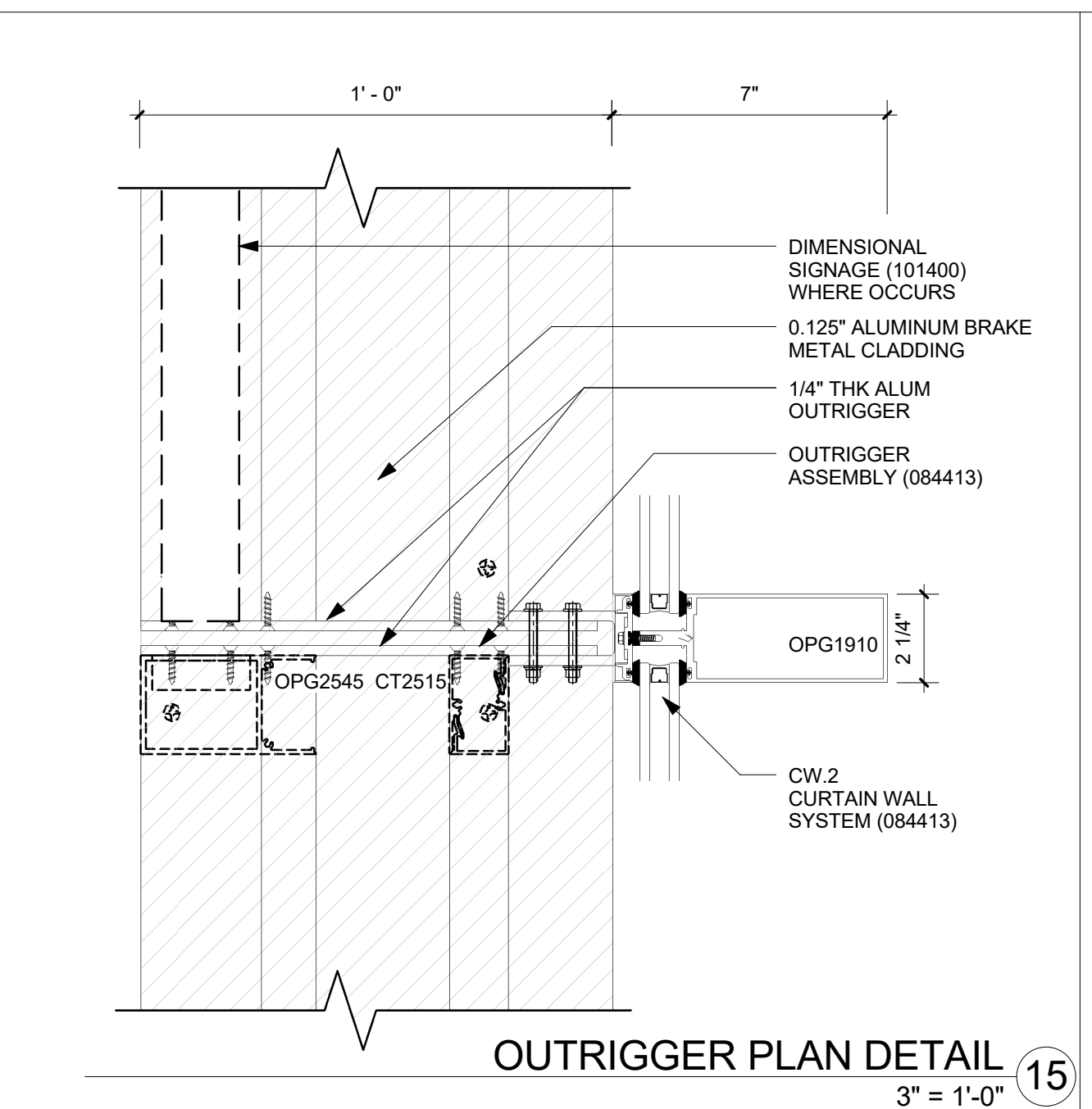

METAL CLAD MULLION OUTRIGGER DETAIL 17
 3" = 1'-0"

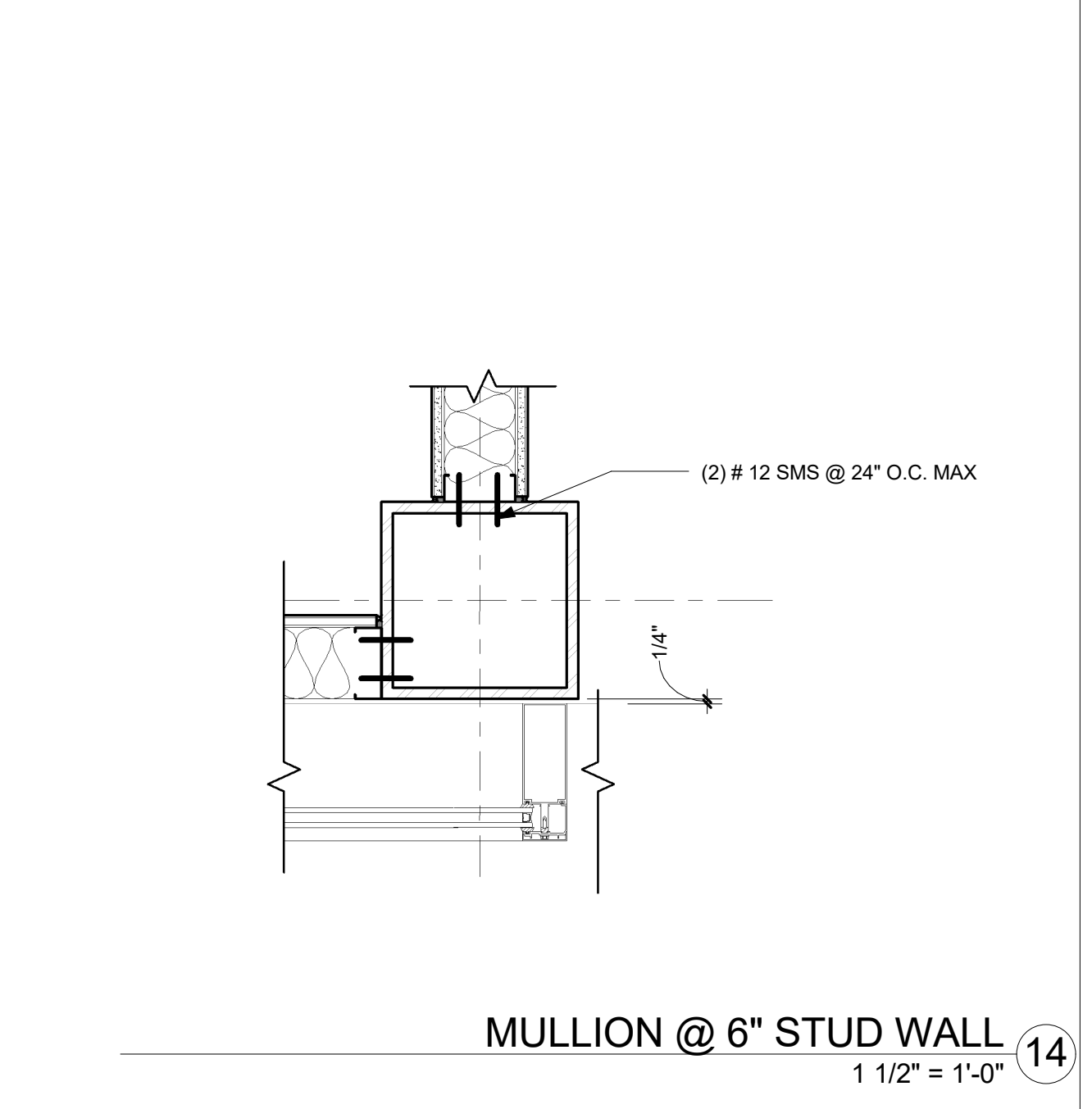

MULLION @ 6" STUD WALL 14
 1 1/2" = 1'-0"