

BASIC ELECTRICITY

STUDY COURSE for Home Appliances

HOW TO READ:

- TIMER SEQUENCE CHARTS (ESTERLINE)
- WIRING DIAGRAMS

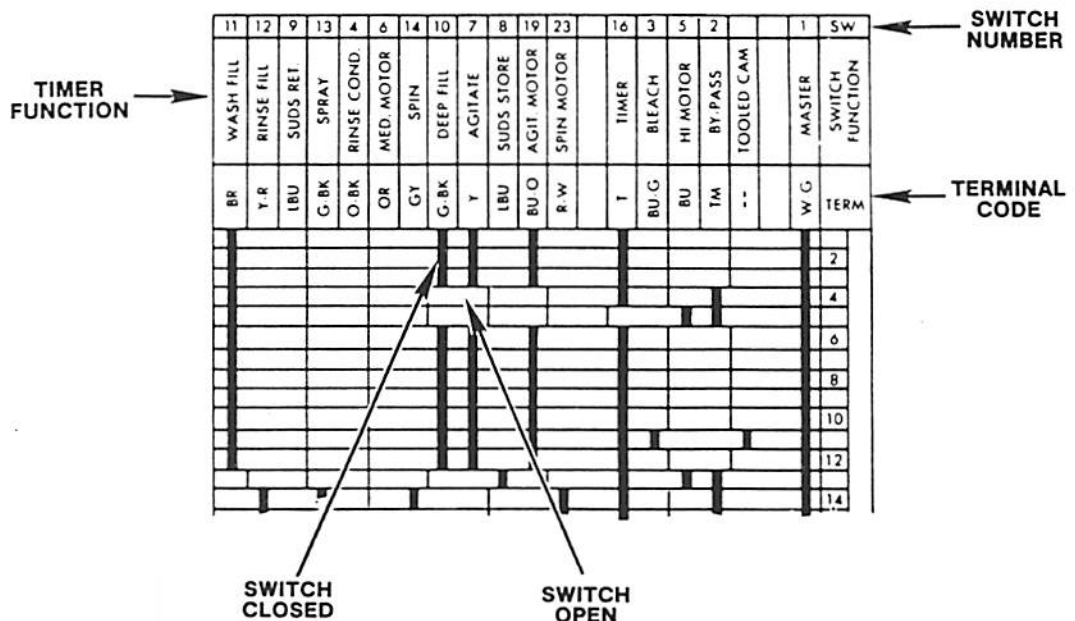

INTRODUCTION

The material presented in this module is intended to provide you with an understanding of the fundamentals of electricity as applied to major appliances.

Major appliances have become more sophisticated, taking them out of the screwdriver and pliers category. Their electrical circuits include several different types of automatic controls, switches, heaters, valves, etc. Semiconductors, solid-state controls, and other components usually associated with radio and television electronic circuits are being engineered into automatic washers, dryers, dishwashers, refrigerators and microwave ovens.

The appliance technician is emerging into a professional status of his own. He must prepare himself now to be able to perform his duties today as well as to retain his professionalism in the future.

No longer is on-the-job training sufficient to prepare technicians for the complicated procedures required for today's sophisticated appliances. This training can best be obtained through organized classroom study and application. However, much of the knowledge necessary to service today's appliances can be obtained through study courses. Completion of this and other courses will provide you with sufficient understanding of appliances and their operation to enable you to do minor service. It will also serve as a valuable stepping stone to more advanced study and on-the-job training to improve your servicing skills.

Information contained in this module is used on WHIRLPOOL® appliances.

TABLE of CONTENTS

	PAGE
CHAPTER 1	3
TIMER SEQUENCE CHARTS (ESTERLINE)	

CHAPTER 2	7
WIRING DIAGRAMS	

*TEST See Test Book LIT787743

**NOTE: We recommend taking the TEST for MODULE 3, right after studying it.*

CHAPTER 1

TIMER SEQUENCE

(ESTERLINE)

Page 5 represents a sample timer sequence chart. Page 6 represents a sample wiring diagram. This detailed chart shows how the timer motor and timer switch operation control machine functions. When the timer switch sequence chart information is compared to the wiring diagram, electrical and mechanical diagnosis can be accomplished. The top horizontal row of numbers across the top of the timer sequence chart represents timer SWITCH NUMBERS. These numbers *will not* be found on the actual timer. They are merely guides to be used to relate between the timer sequence chart and the wiring diagram. The timer switch functions are shown directly below the timer switch numbers. These relate to the function controlled by that switch contact.

The letters below the timer switch functions, such as LBU, GY, G-BK, O-BK, etc., represent the *actual* timer terminal markings and wiring color code.

The vertical column at the right of the timer sequence chart shows the cycles of machine operation. As you can see, in this particular chart we are only showing three cycles—NORMAL or REGULAR/HEAVY, GENTLE and PERMANENT PRESS as well as special cycles—SUPER WASH. To the right of each cycle are the machine functions for that cycle.

The columns under the machine function heading give the basic operation on the left, and the supporting functions on the right, for each timer step.

Even numbered timer steps are shown to the left of the wash cycles. The odd-number steps are not shown, to avoid confusion and an overcrowded appearance. Each timer space represents a definite period of time.

Closed switches for the components of each timer step are represented by the HEAVY VERTICAL BARS in the timer switch sequence chart.

The timer switch sequence chart explains the when, what, why and how of machine function at any selected point of operation.

To properly diagnose a problem, the electrical circuitry and the wiring diagram, attached to the product must be thoroughly understood. Let's first study each part of the wiring diagram.

On page 6 the symbol shown at the top of the page by the letters BK, G and W represents the line cord attachment plug. The line marked W extends down the right side of the diagram and is known as the "neutral side" of the electrical system. Note that this line connects directly to one side of each energy converting (electrical to mechanical) component of the automatic washer, without any controlling switch.

The line shown as BK extends to the left and is known as the "hot side" of the electrical system. It provides a circuit to the master switch (No. 1) and to all electrically operated components through the timer switches, and/or the water level and temperature switches.

The heavy black lines connected to numbered switches represent circuits and switches within the timer assembly.

The pull-on, push-off timer knob switch controls all circuits. This switch starts automatic washer operation when the timer knob is pulled out, and stops when it is pushed in.

All timer switches are numbered to correspond with the timer sequence chart. A given machine component is always controlled by the same timer switch number, regardless of the model. For example: Five (5) is always reserved for high motor speed; seven (7) is always reserved for agitation, etc.

Wiring harnesses are color coded, to match the color-coded lettering imprinted on the wires of the timer-terminal connections. A given automatic washer component always uses the same wiring harness color and color code lettering, regardless of model. Example: BU (Blue) is always used for high motor speed; Y (Yellow) is always used for agitation.

A given component is always shown at the same position on the wiring diagram. The water temperature switch is shown within dashed lines, near the bottom of the wiring chart. The lettering at the right of the switch contacts indicates present contacts for various combinations of wash and rinse water temperature selections. The first letter represents WASH water temperature, while the second letter identifies RINSE water temperature.

Since studying and learning information has no value until it is applied, let's follow a step-by-step procedure to diagnose a machine malfunction.

For an example, say the washer was set in the GENTLE cycle with the water temperature switch set at HOT WASH and COLD RINSE, and that the washer will not FILL. A rule is to always check the easy and obvious first.

Is there power to the machine? Be sure the machine's power cord is plugged into a live wall receptacle. Next, be sure the water faucets are turned On! Also, make sure the timer dial indication coincides with the timer function.

Let's assume in our example that, having completed all the normal examinations, the machine still does not FILL. Turn to the wiring diagram and timer sequence chart. By using this information, you can determine which circuits and components are affected in an appliance's electrical system at any given time. The wiring chart is easy to follow when a step-by-step checking sequence is used.

Fill, in the GENTLE cycle, takes place in timer Step 26. Let's start by drawing a line horizontally through timer Step 26 on the timer sequence chart and note the closed circuits.

The closed switches are switch no. 1 (master), 16 (timer), 19 (agitate motor), 7 (agitate), 10 (deep fill) and switch no. 11 (wash fill).

Now close these switches on the wiring diagram on page 6. As you can see by the heavy line, the electricity on the "BK" side of the line flows through switch no. 1, the water level switch (empty), temperature switch and the mixing valve and then back through the "W" side of the line, completing a circuit.

Since our problem is "No Fill," the first thing to do is turn your timer dial to the start of the GENTLE cycle.

Did the light, if used, turn on? If so, timer switch 1 is ok. Now turn your timer dial to SPIN and pull the knob out. Did your automatic washer start to spin? If so, the water level switch is ok. Now you will have to check out timer switches 10 and 11, the temperature switch and the mixing valve to find and correct the problem.

When the correct water level is reached, the switch trips from "P" (empty) to "T" (full).

With the water level switch tripping from "P" to "T," there is no electricity through switches 10 and 11, temperature switch and the mixing valve.

Electricity flows from the "BK" side of the line through switch no. 1, the water level switch (full), agitate solenoid, speed switch/drive motor and timer motor all at the same time, completing a circuit through the "W" side of the line.

You can also see when switch no. 1 is closed. This completes a circuit through the ballast and fluorescent lamp, no matter what the water level switch is doing.

SAMPLE TIMER SEQUENCE CHART (ESTERLINE)

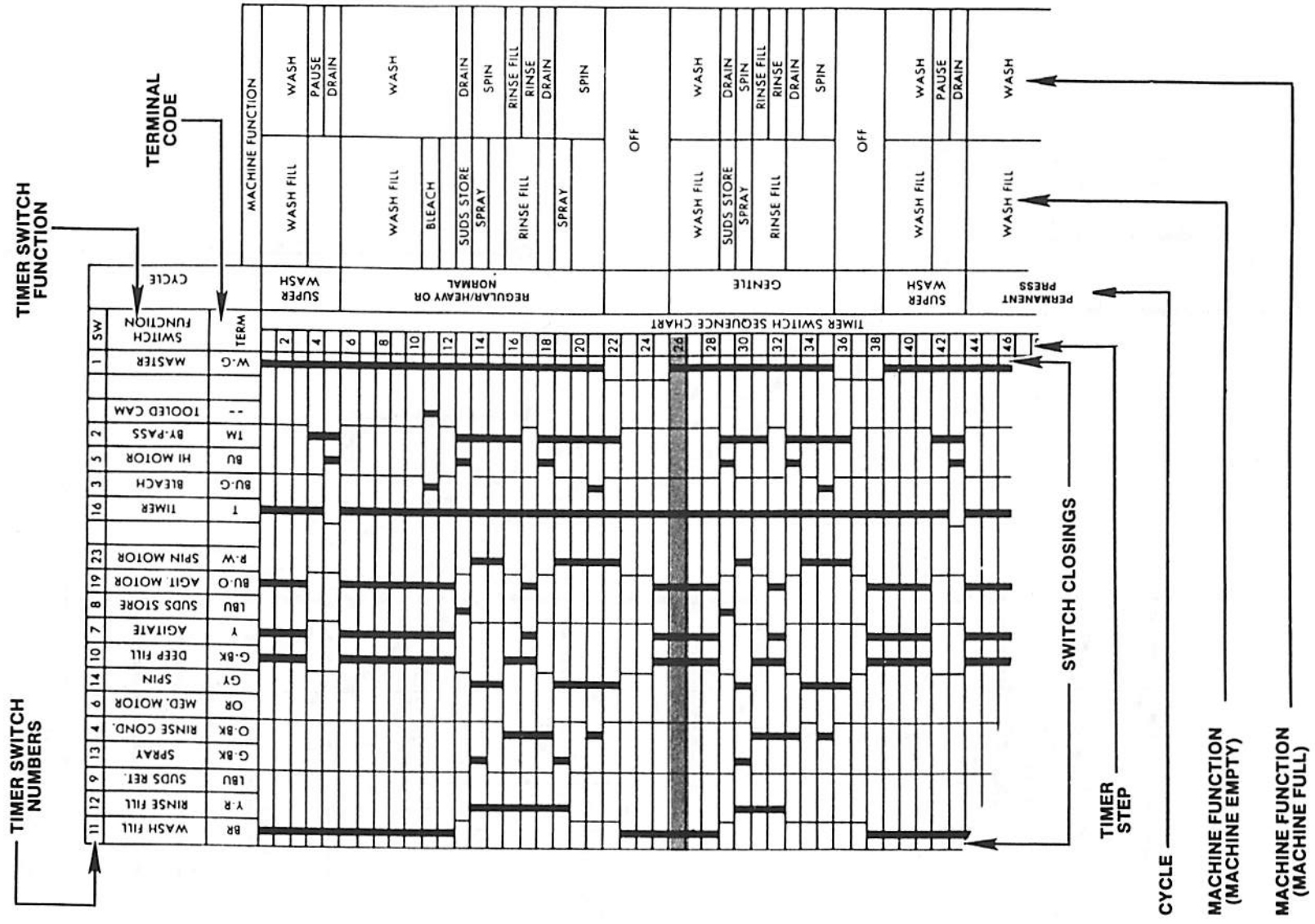

SAMPLE WIRING DIAGRAM

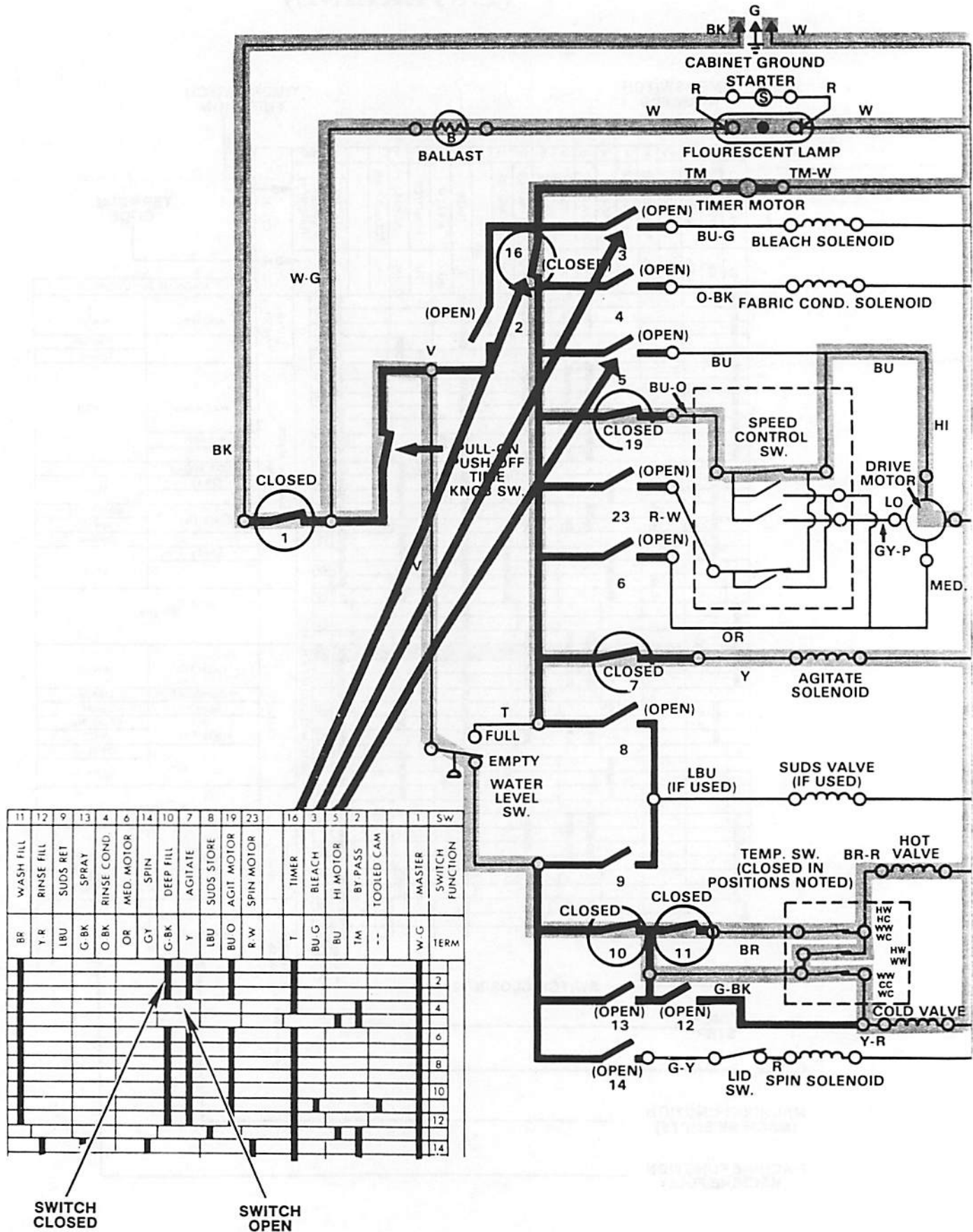

CHAPTER 2

WIRING DIAGRAMS

In this chapter each page is a typical wiring diagram. You will find the response on the back of the page.

Let's take a look at a wiring diagram for an automatic washer. Note switch number 1 on the diagram. It is first in line and is the master switch. No circuits are energized when the dial is in the "off" position. Turn the dial to any operating position and one circuit is energized even before you operate the push-pull switch by pulling the knob.

WITH YOUR PENCIL, CLOSE SWITCH 1 AND DRAW A WAVY LINE THROUGH THE ENERGIZED CIRCUIT.

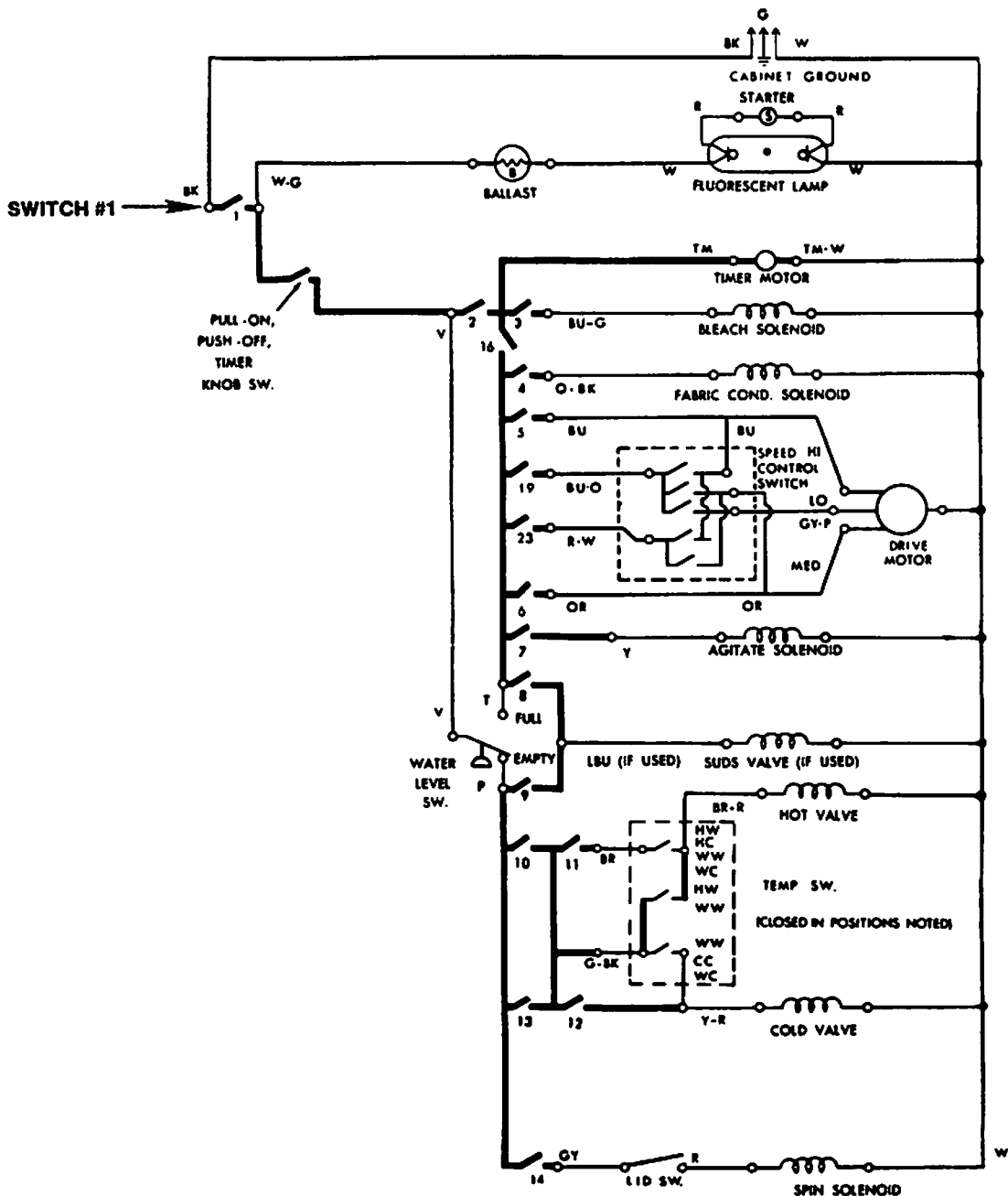

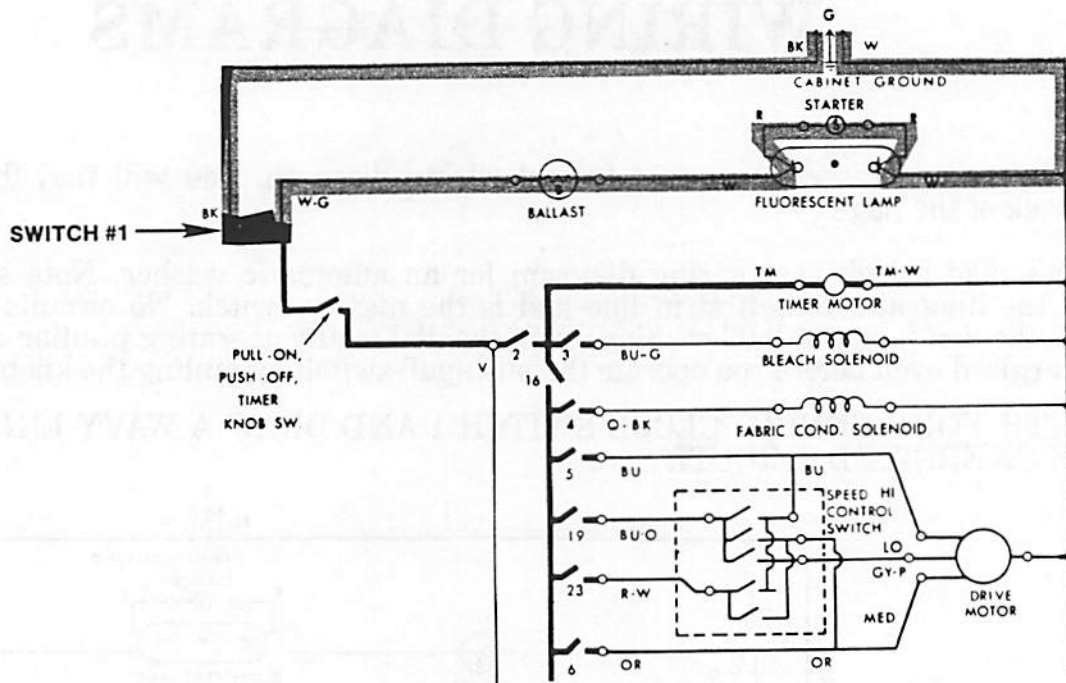

OR

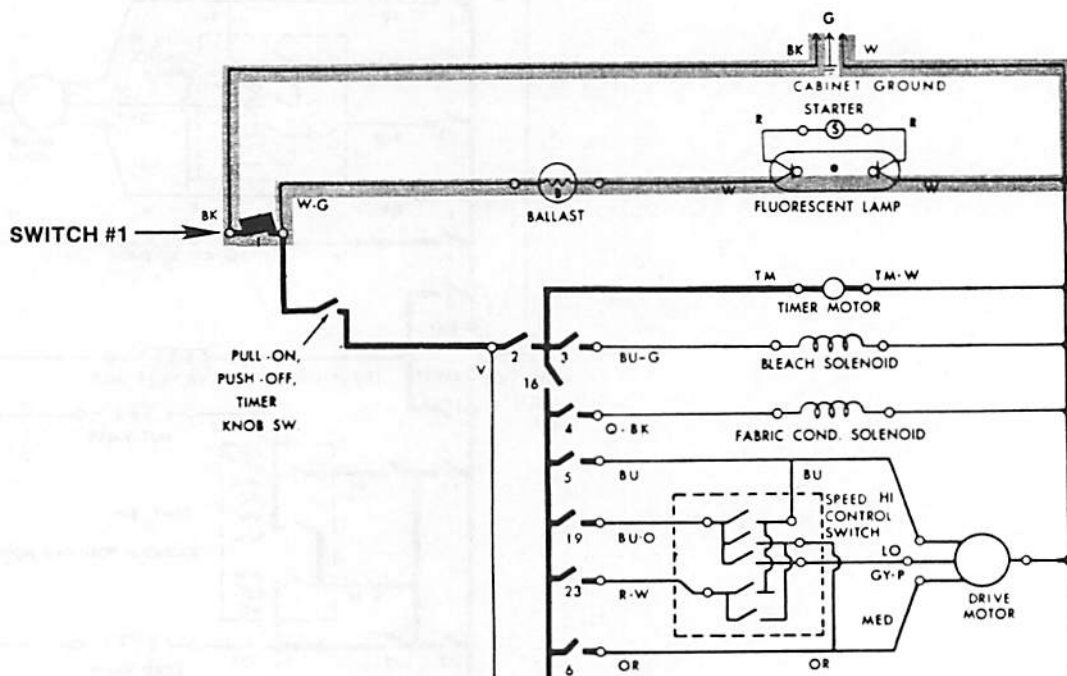

You did so well with that last circuit that we can progress to more involved circuits. Let's assume that you have selected the "wash" cycle that gives you hi-motor agitation, your water temperature, and have started the washer. The timer has advanced to a position where it has closed timer switches 1, 5, 7, 10, 11 and 16.

In the diagram below we have closed the proper contacts in the water temperature switch.

YOU CLOSE TIMER SWITCHES 1, 5, 7, 10, 11 AND 16, AND TRACE THE CIRCUITS WITH A WAVY LINE.

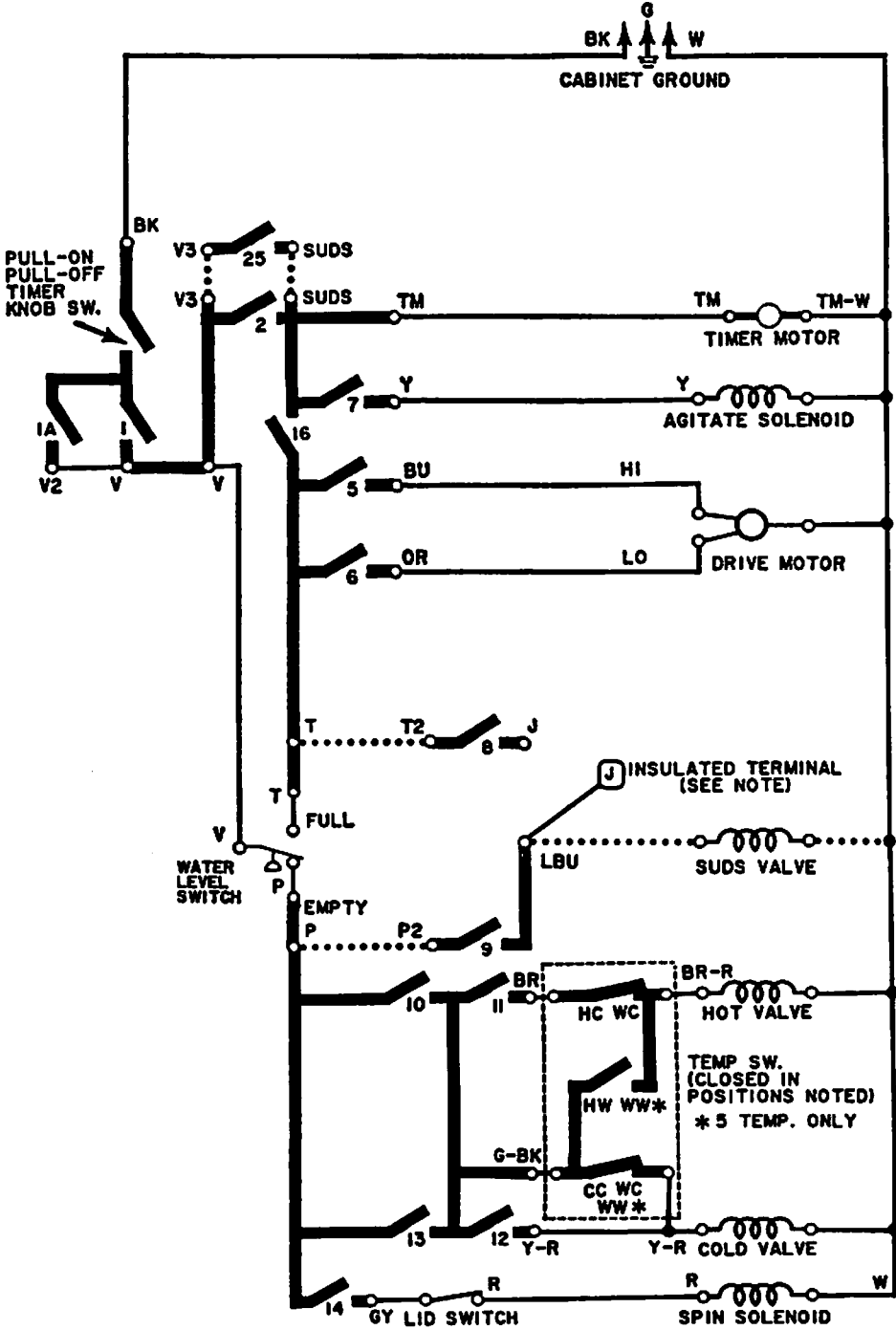

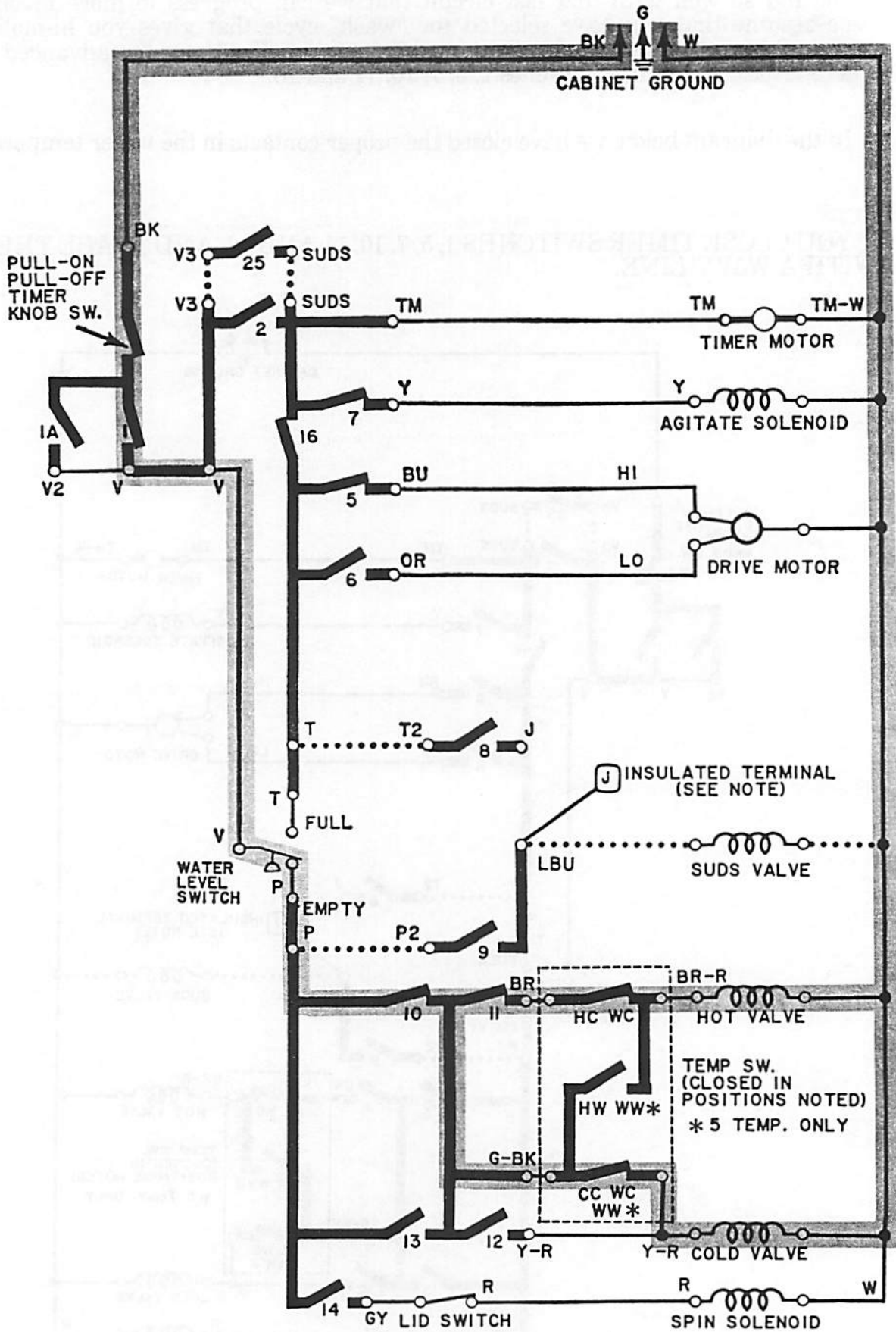

Very good! In the last diagram the washer was filling with water. By looking at the response you can see that neither the main drive motor, agitate solenoid nor the timer motor circuits were energized. In the diagram below the water level switch has moved to the FULL position because the washer has filled with water. The same timer switches that were closed in the last diagram are closed. We have closed them for you. DRAW A WAVY LINE THROUGH THE ENERGIZED CIRCUITS.

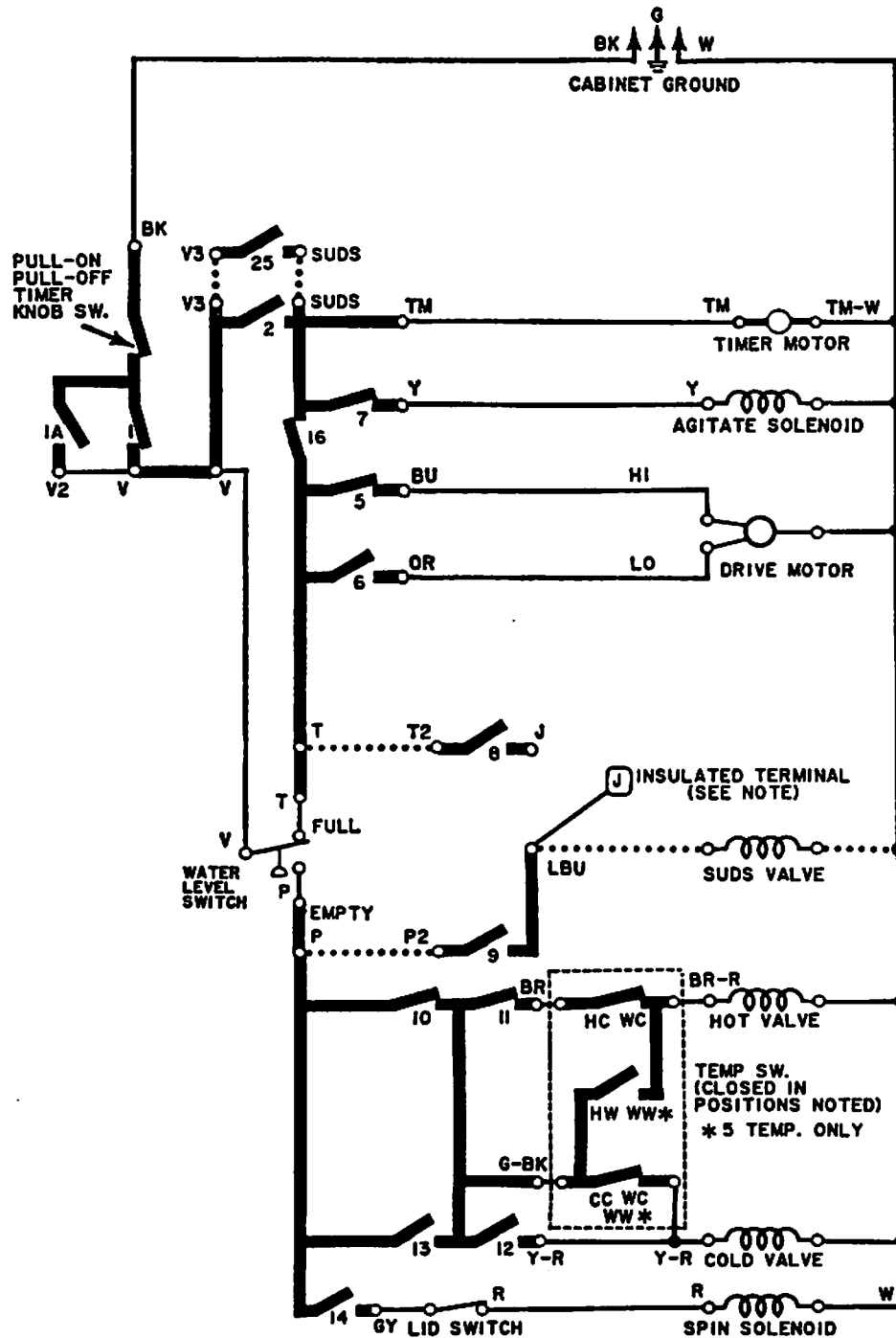

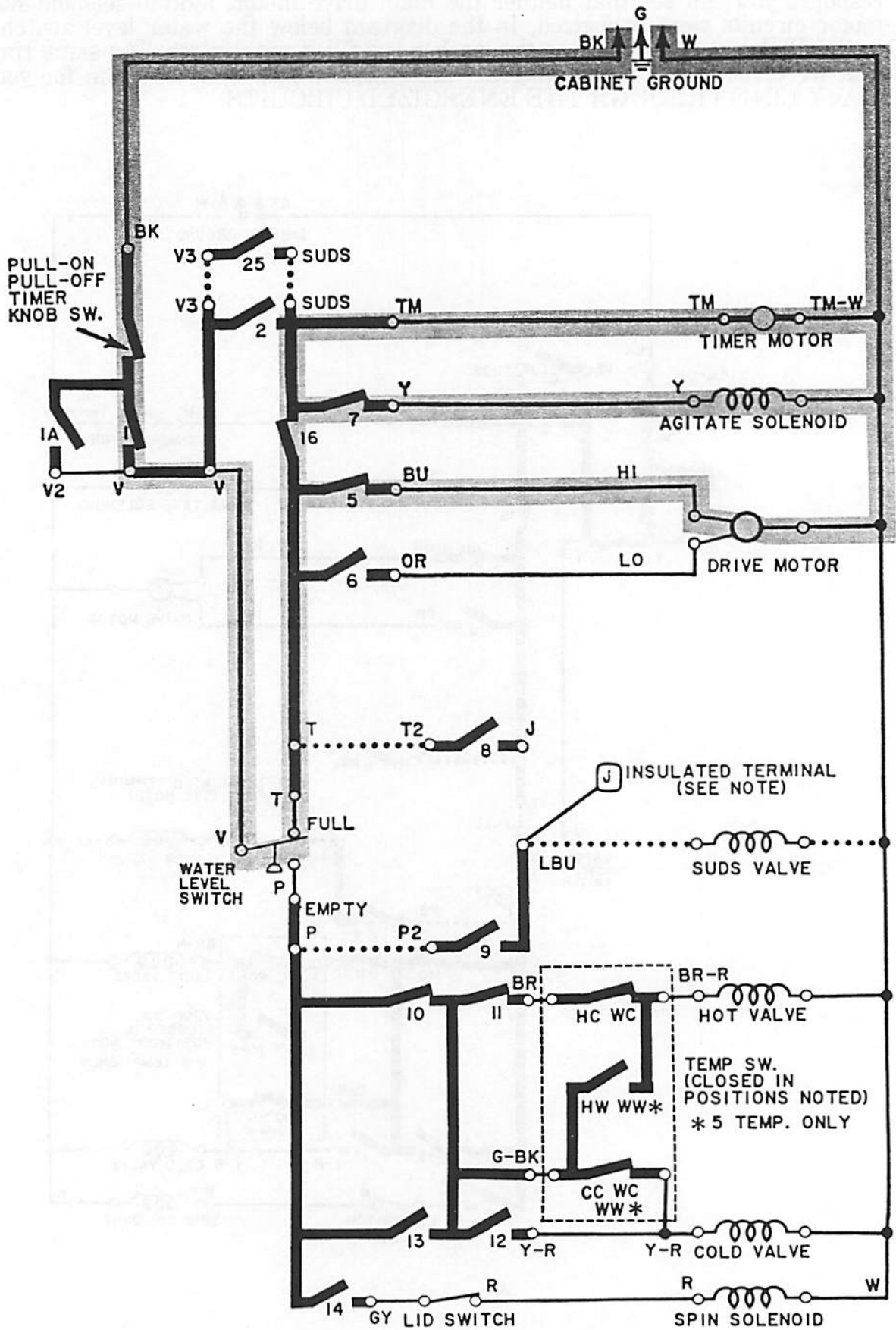

You are doing very well! Now let's suppose the timer has advanced and closed timer switches 1, 2, 5, 14 and 16. The LID SWITCH is also closed because the lid is shut. This puts the washer in the SPIN cycle. We have closed the switch contacts in the water temperature switch for you as we have done in the past diagrams.

CLOSE SWITCHES 1, 2, 5, 14 AND 16, AND TRACE THE CIRCUITS WITH A WAVY LINE.

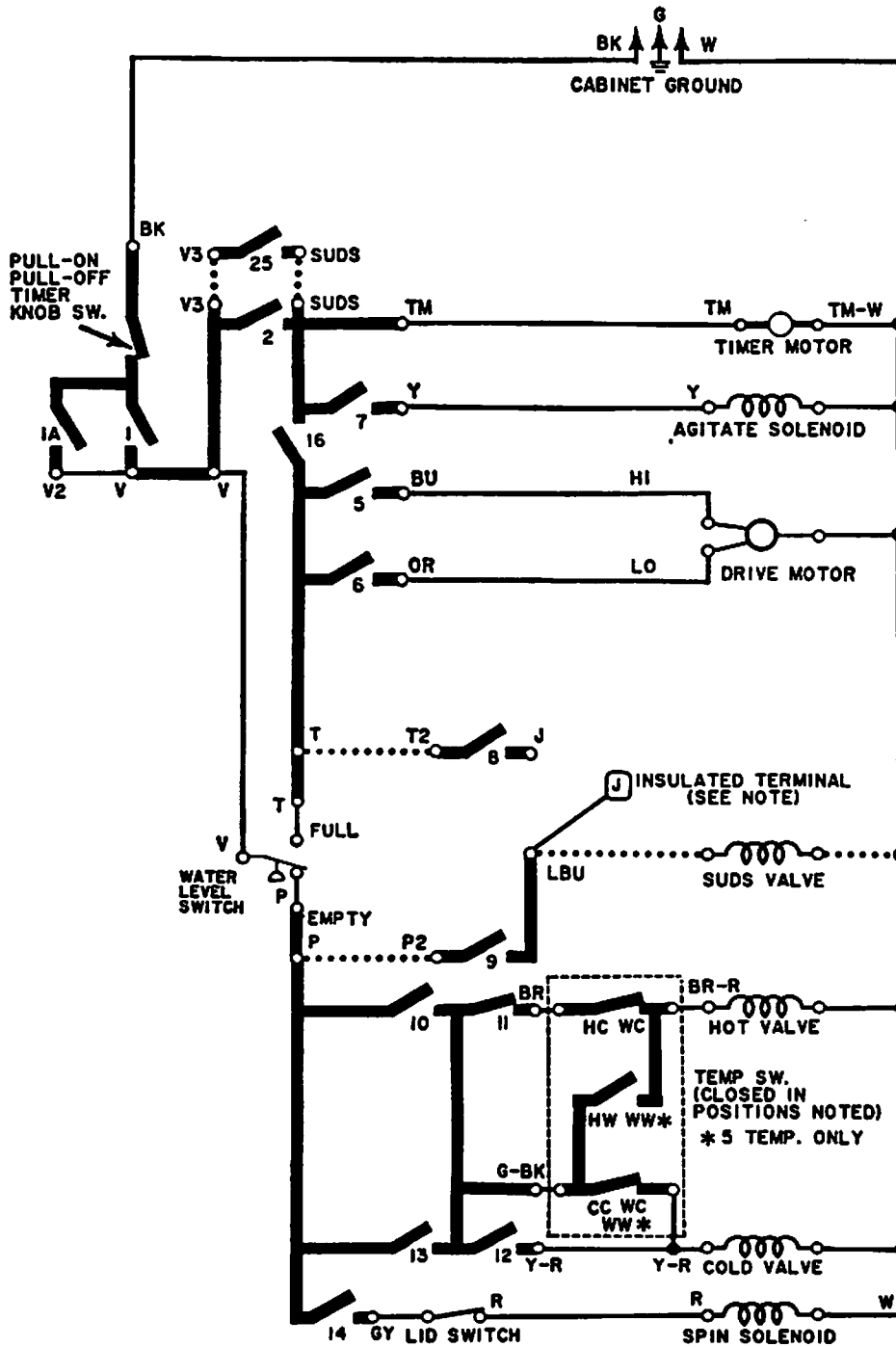

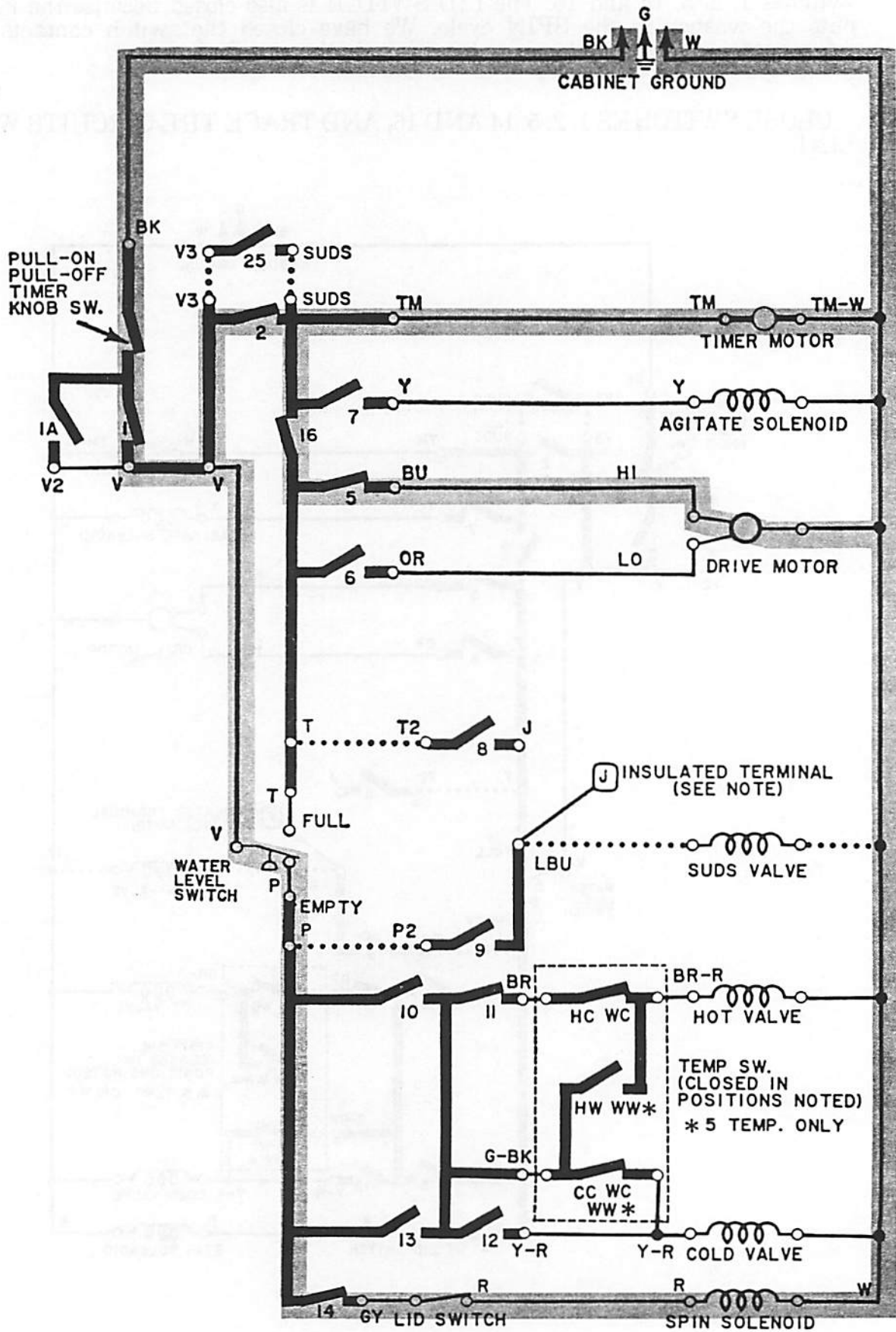

You did so well with the automatic washer diagrams that you should have no trouble with a wiring diagram for an electric clothes dryer.

In the wiring diagram below the customer has selected the "REGULAR" drying cycle by turning the timer dial and has closed the dryer door. However, she has not pushed the "Push-to-Start" relay yet.

At the instant of start, when she pushes the "Push-to-Start" relay, which circuits are energized?

We have closed the timer switches for you. WITH YOUR PENCIL, TRACE THE ACTIVE CIRCUITS WITH A WAVY LINE.

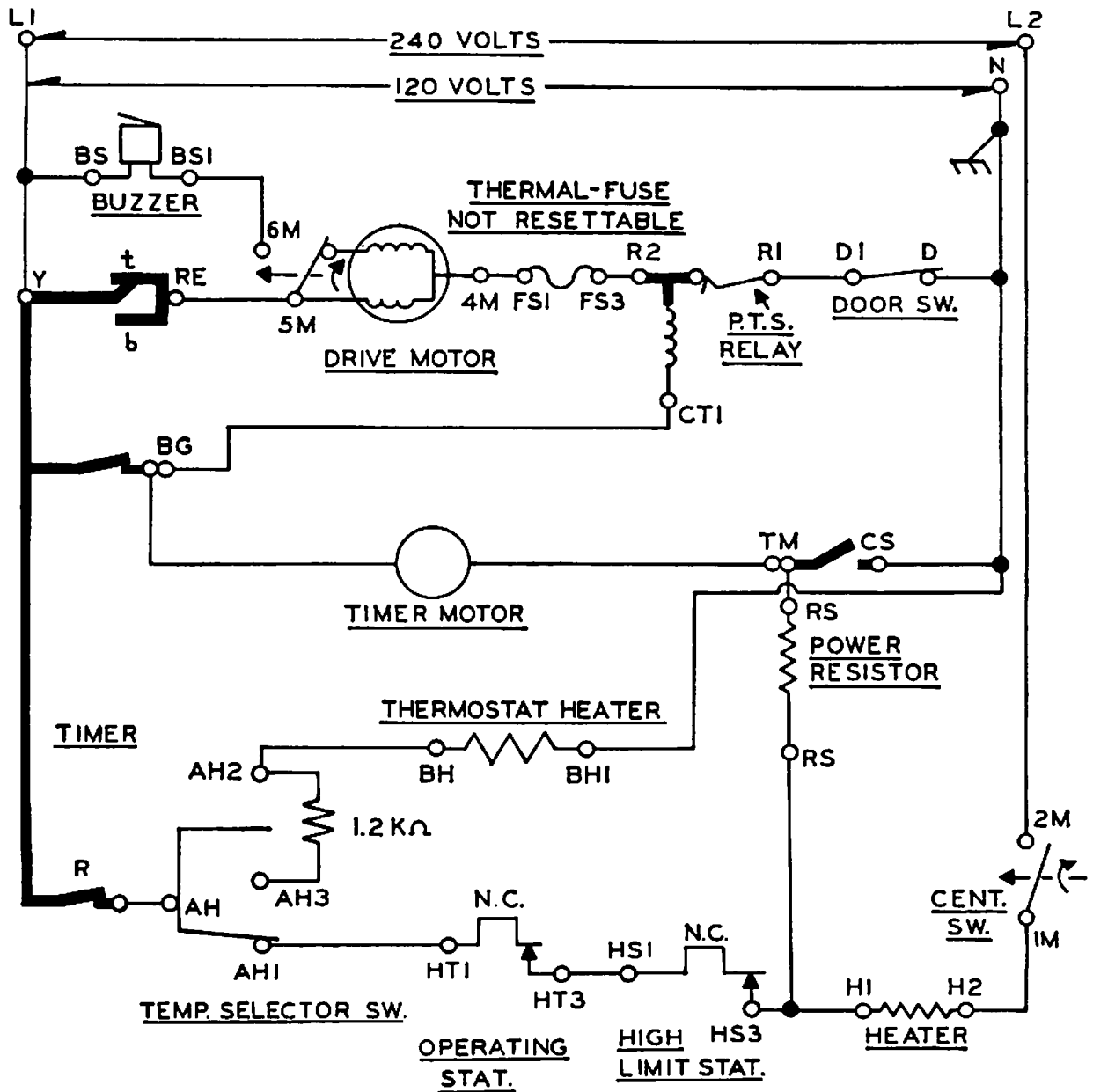

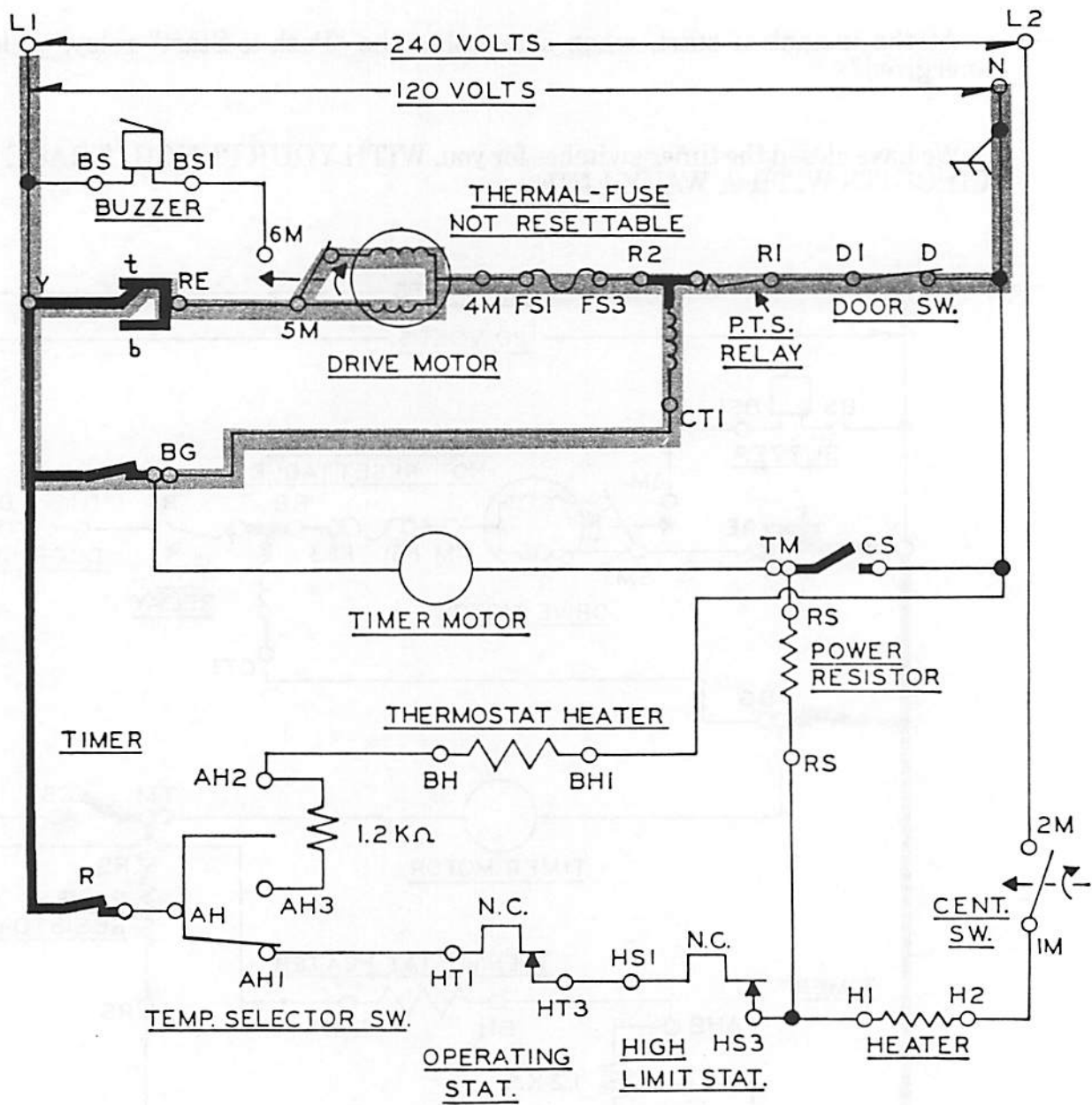

The wiring diagram on this page shows the circuits that are made with the dryer running in the "REGULAR" cycle. We have closed the proper switches for this condition for you.

DRAW A WAVY LINE THROUGH ALL OF THE ACTIVE CIRCUITS IN THE WIRING DIAGRAM BELOW.

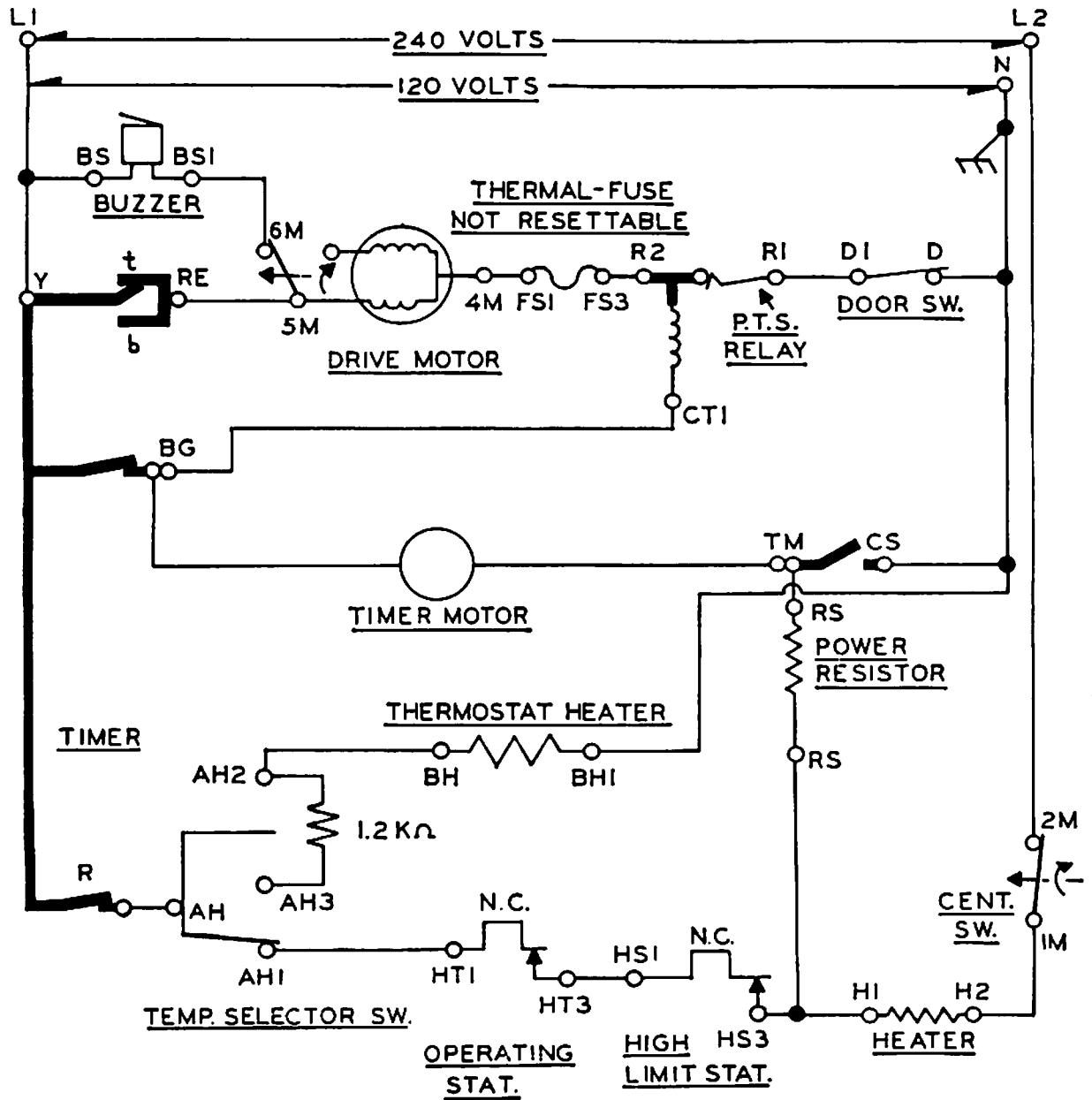

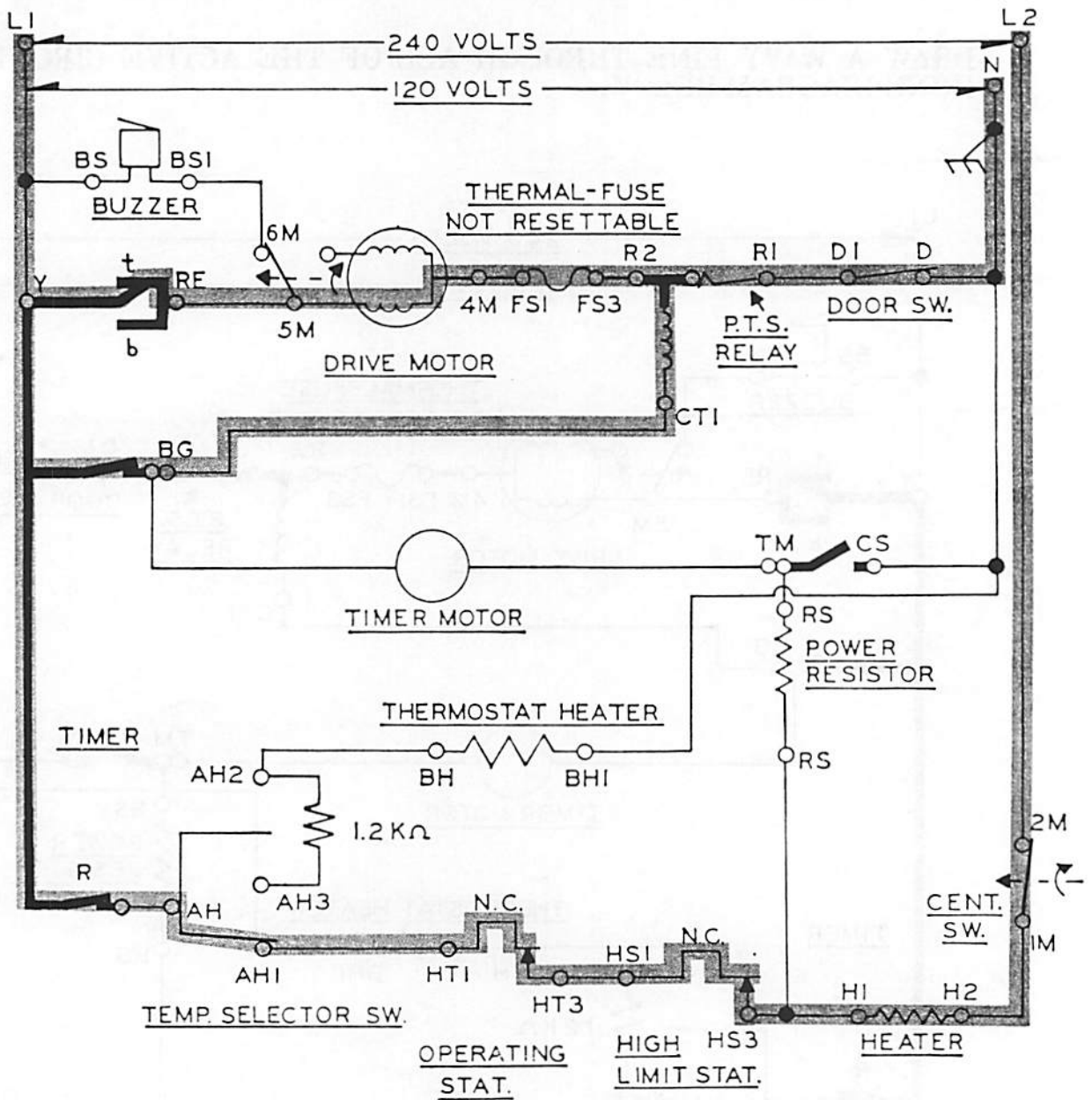

Did you show the buzzer circuit as an active circuit? Remember, it is a basic principle of electricity that current will always follow the path of least resistance. In this case the current bypassed the buzzer circuit and flowed through timer contacts Y-BG and the drive motor circuit—a line of least resistance.

During the "REGULAR" cycle there is no circuit to the timer motor when there is a circuit to the heat source. When the dryer reaches a certain temperature the thermostat will break the circuit to the heat source. This allows the timer motor to run with the active circuit through the power resistor and heater until the dryer cools. The thermostat then closes and makes the circuit to the heat source again. This cycling continues until the timer motor has advanced to the "OFF" position. IN OTHER WORDS, IN THE "REGULAR" CYCLE: HEAT ON—TIMER OFF, HEAT OFF—TIMER ON.

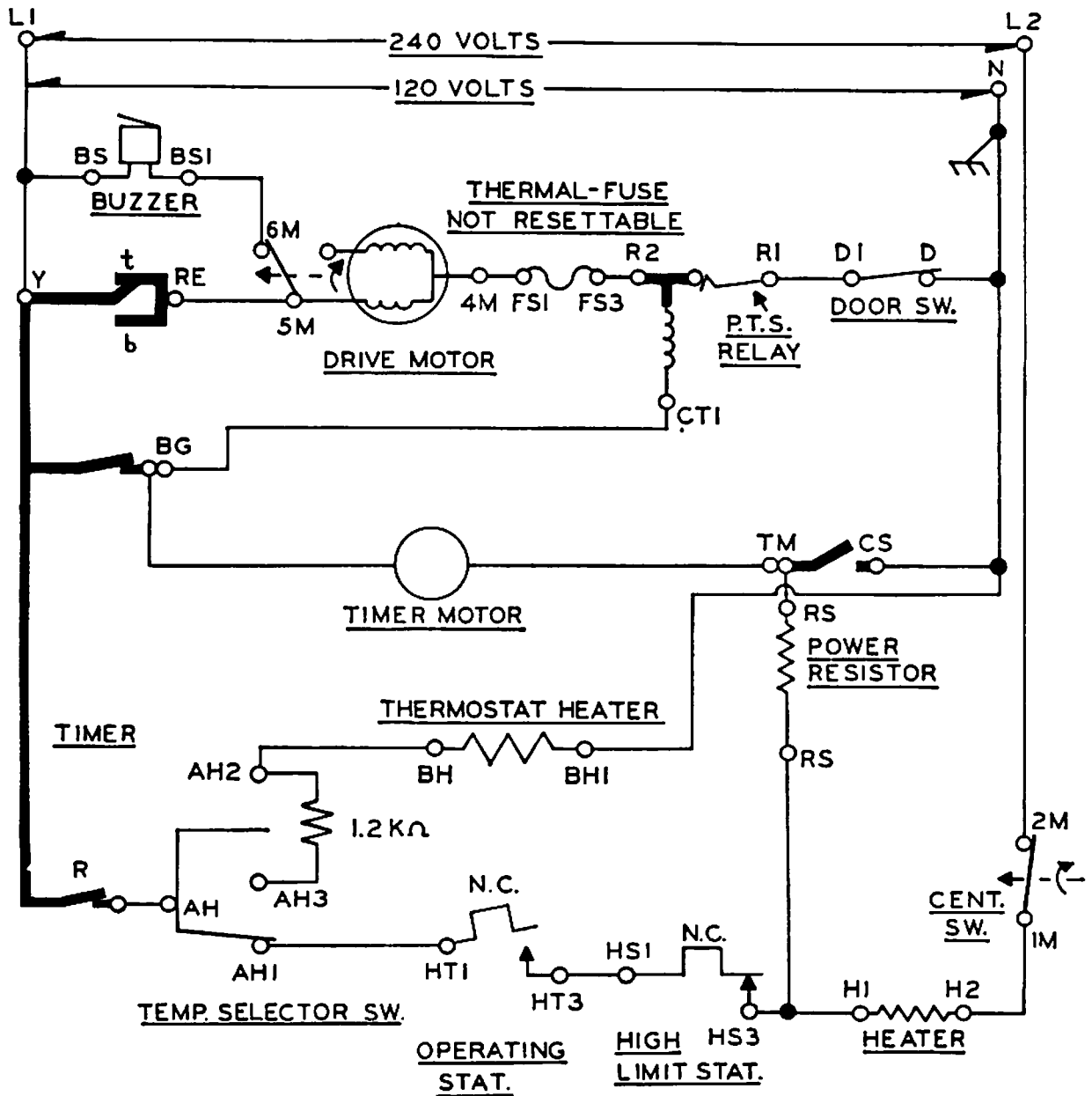

TRACE THE ACTIVE CIRCUITS BY DRAWING A WAVY LINE THROUGH THEM.

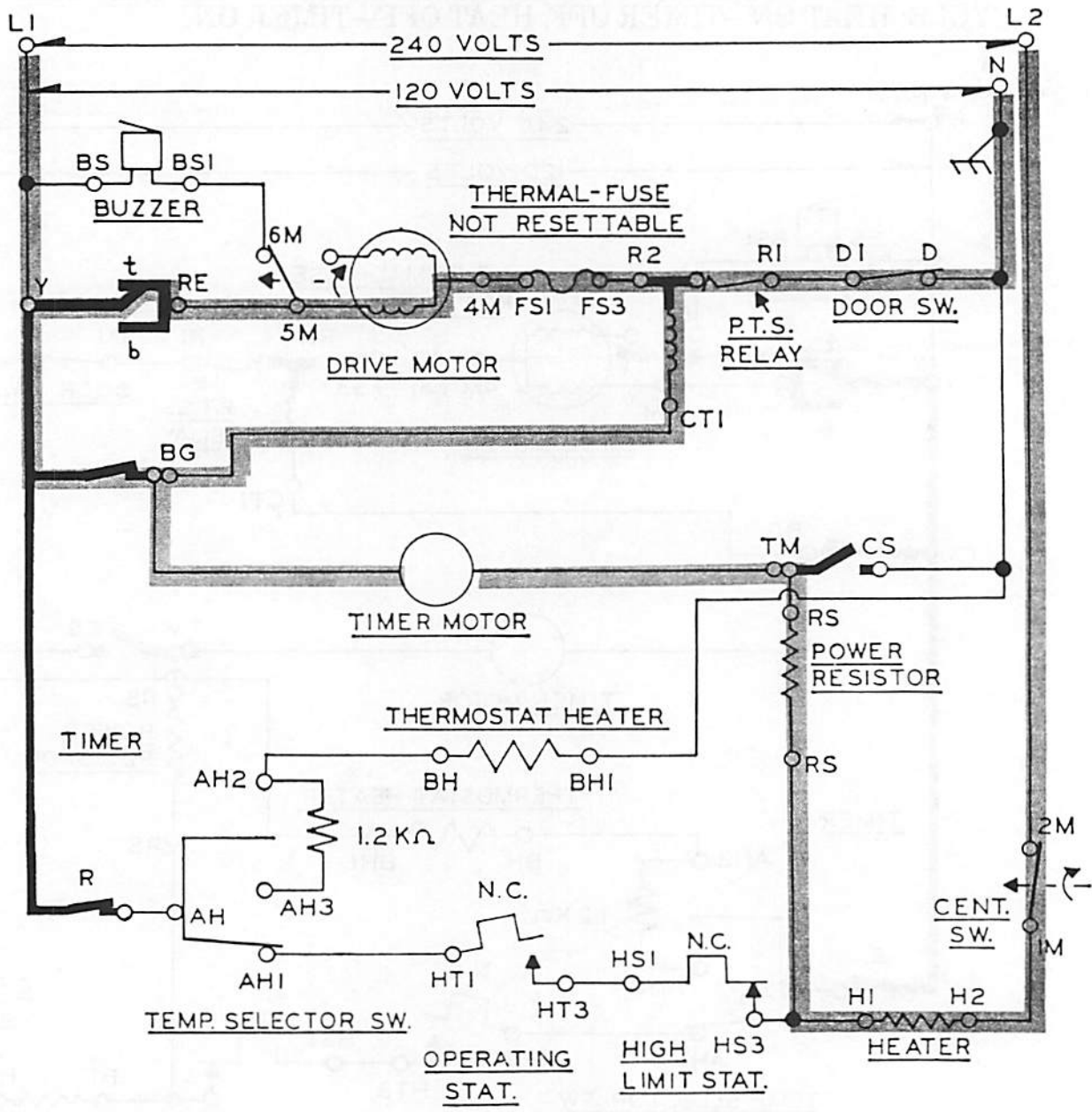

With 5 minutes left at the end of the "REGULAR" cycle, timer switches Y-R open and TM-CS close. Timer contact Y-RE(T) opens the circuit to the drive motor and allows a momentary circuit to be completed through the buzzer and run windings of the drive motor. As the motor slows down, centrifugal switch 5M to 6M opens. This opens the buzzer circuit causing it to stop buzzing.

TRACE THE ACTIVE CIRCUIT WITH A WAVY LINE.

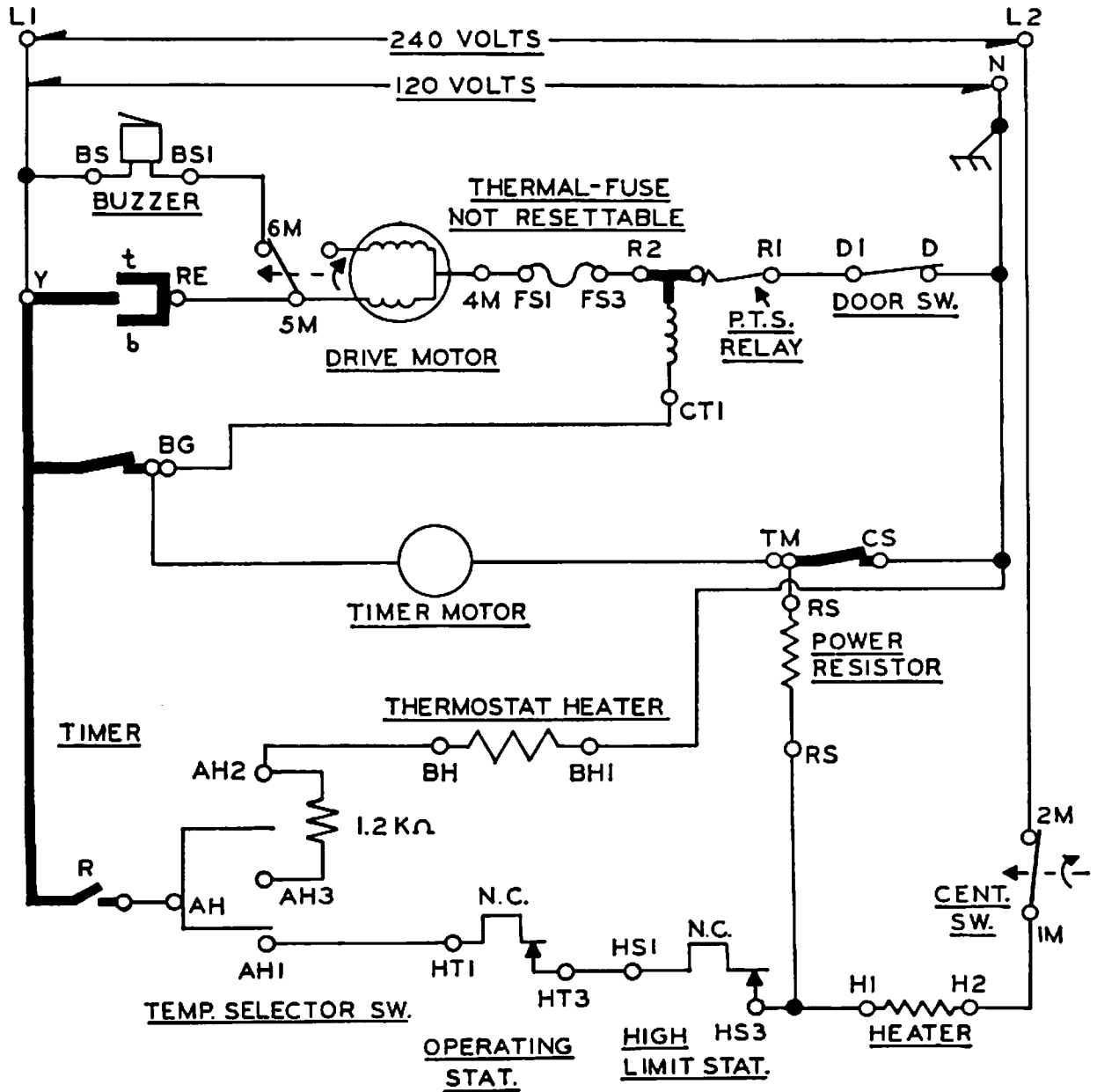

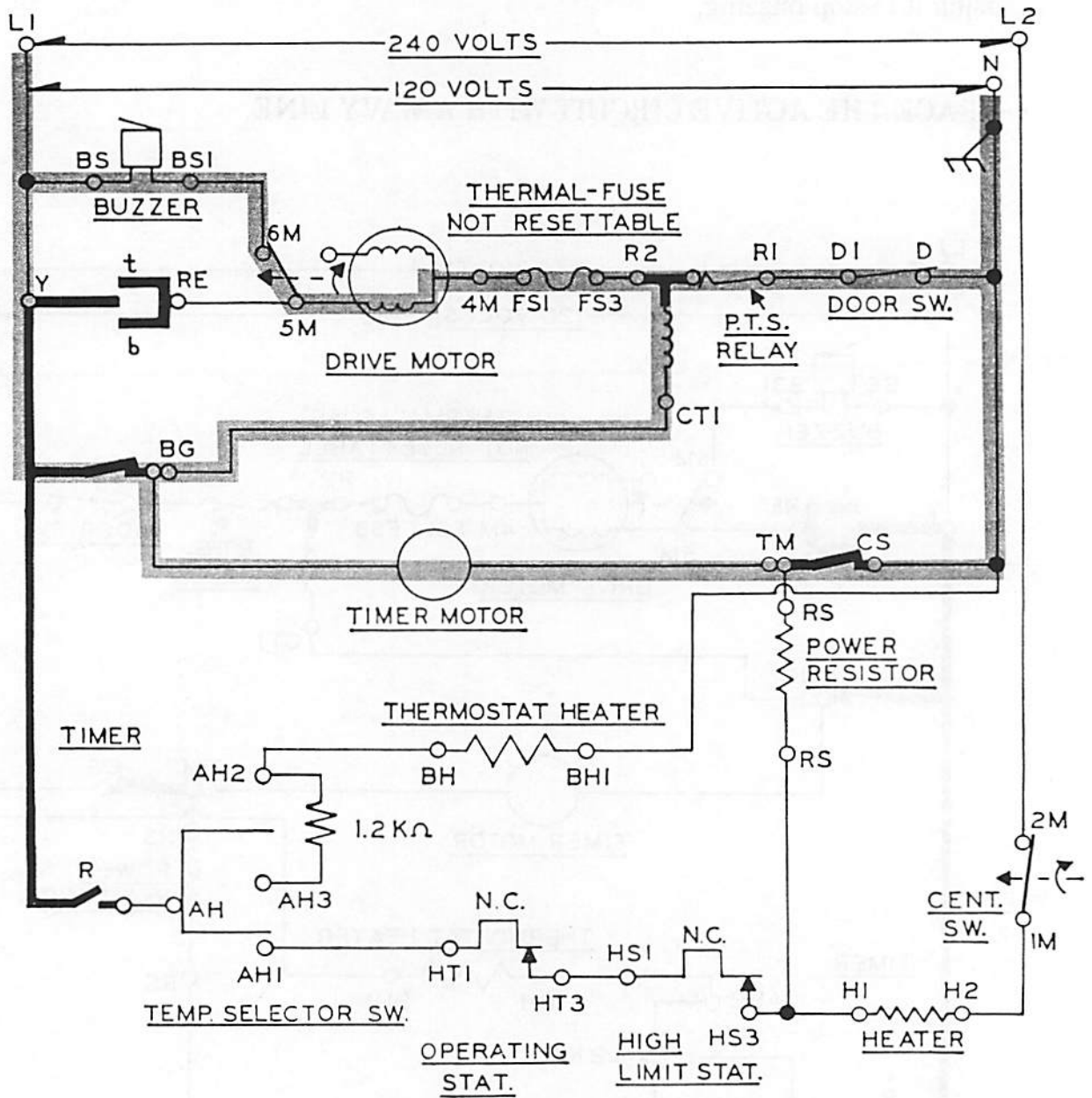

The wiring diagram on this page is for a cycle defrost refrigerator. Let's assume that the thermostat is calling for cooling and the compressor is running. TRACE THE ACTIVE CIRCUITS WITH A WAVY LINE.

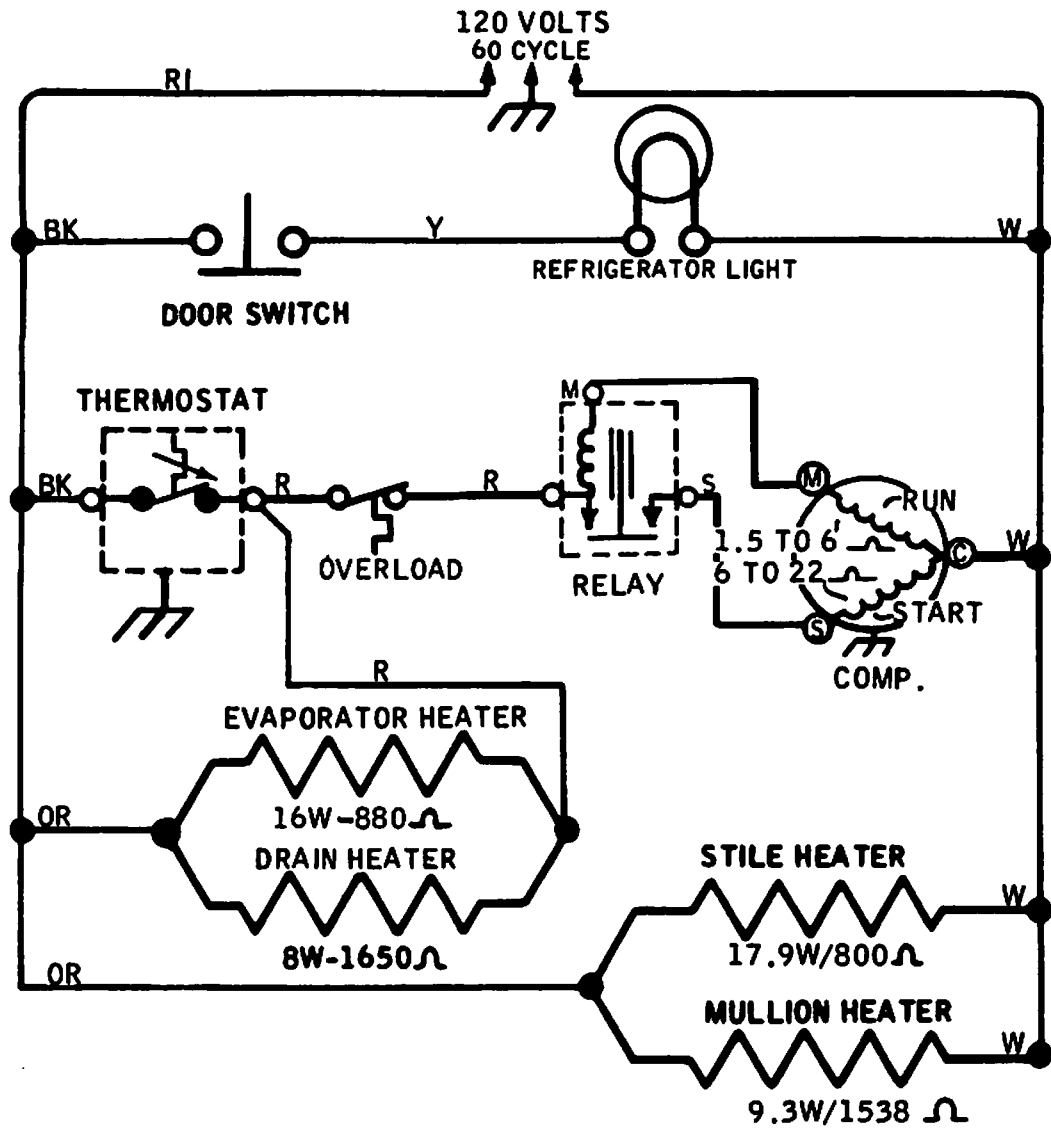

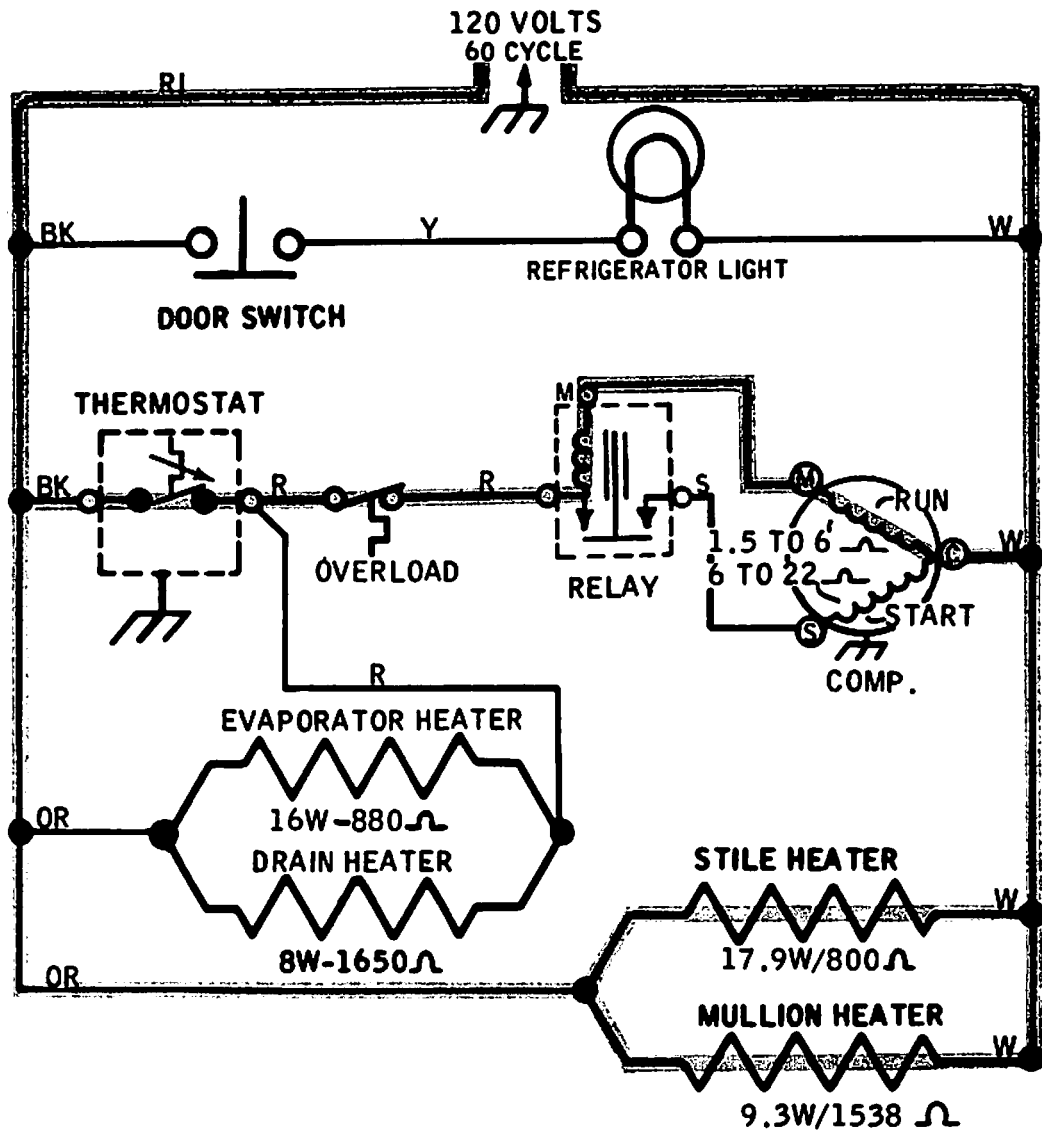

Did you show the parallel circuit for the evaporator heater and drain heater as an active circuit? One of the basic principles of electricity is that current will always follow the path of least resistance. In this case the current bypassed the parallel evaporator-drain heater circuit and flowed through the thermostat contacts, a line of least resistance, and on to the compressor.

The thermostat in the wiring diagram for the cycle defrost refrigerator in this diagram is open. TRACE THE ACTIVE CIRCUITS WITH A WAVY LINE.

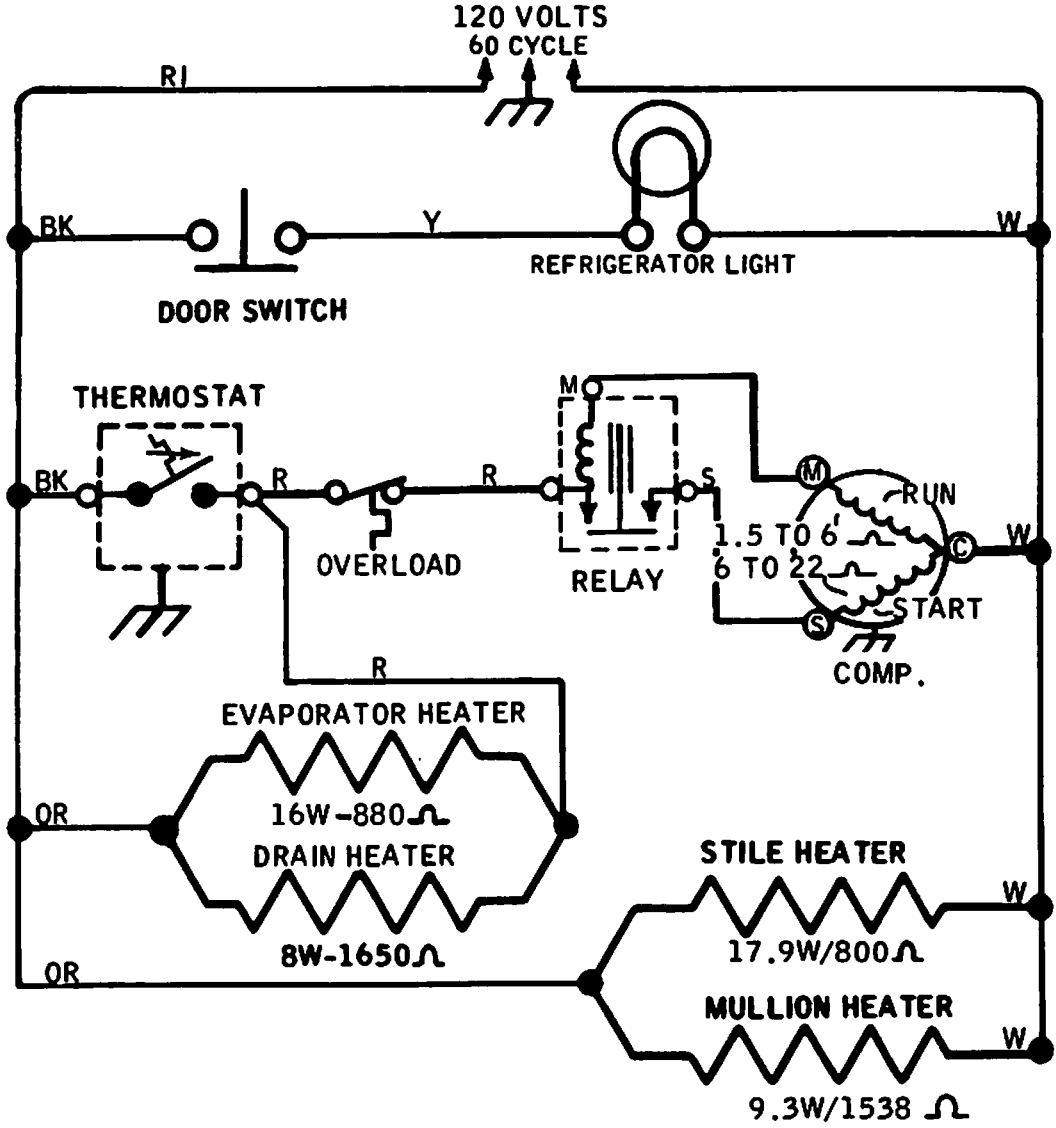

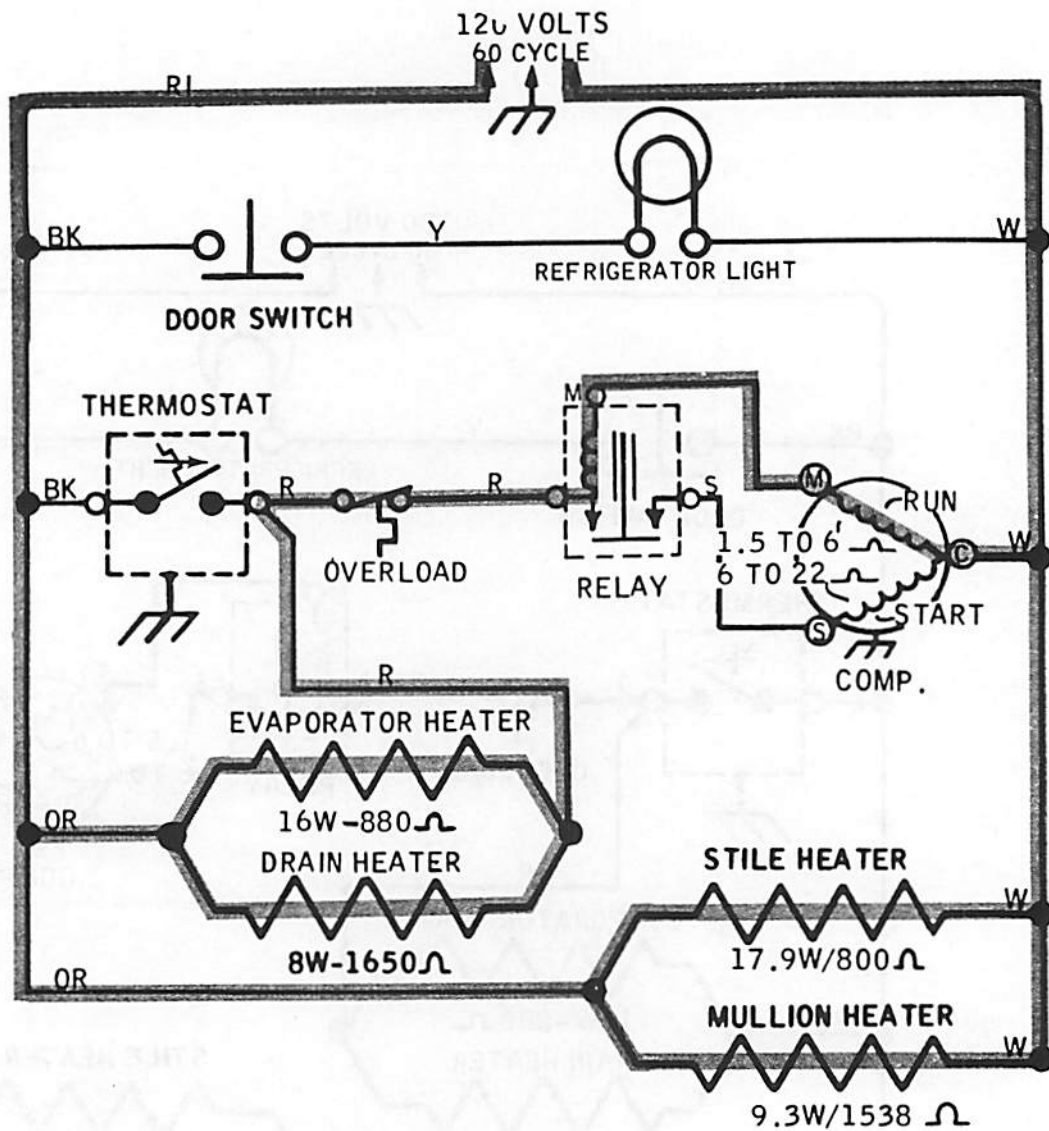

The parallel evaporator-drain heater circuit is now active. Although current is flowing through the relay coil and the compressor run winding, there is not enough current to energize the start relay and run the compressor.

This wiring diagram is for a no-frost refrigerator. Note the defrost timer in the lower left part of the diagram. The defrost timer is closed to contact number 4 and the thermostat is calling for cooling, and the compressor is running.

TRACE THE ACTIVE CIRCUITS WITH A WAVY LINE.

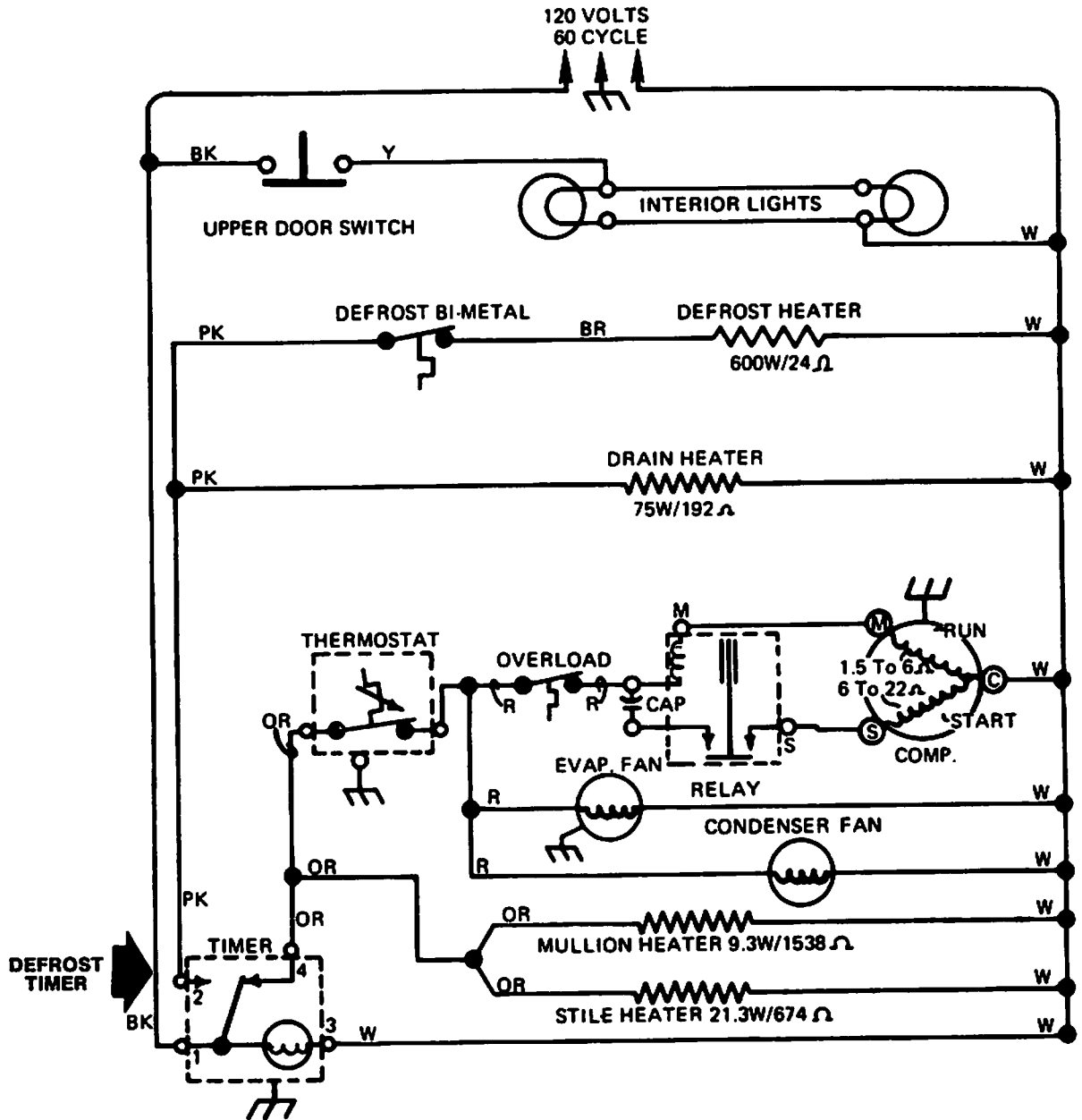

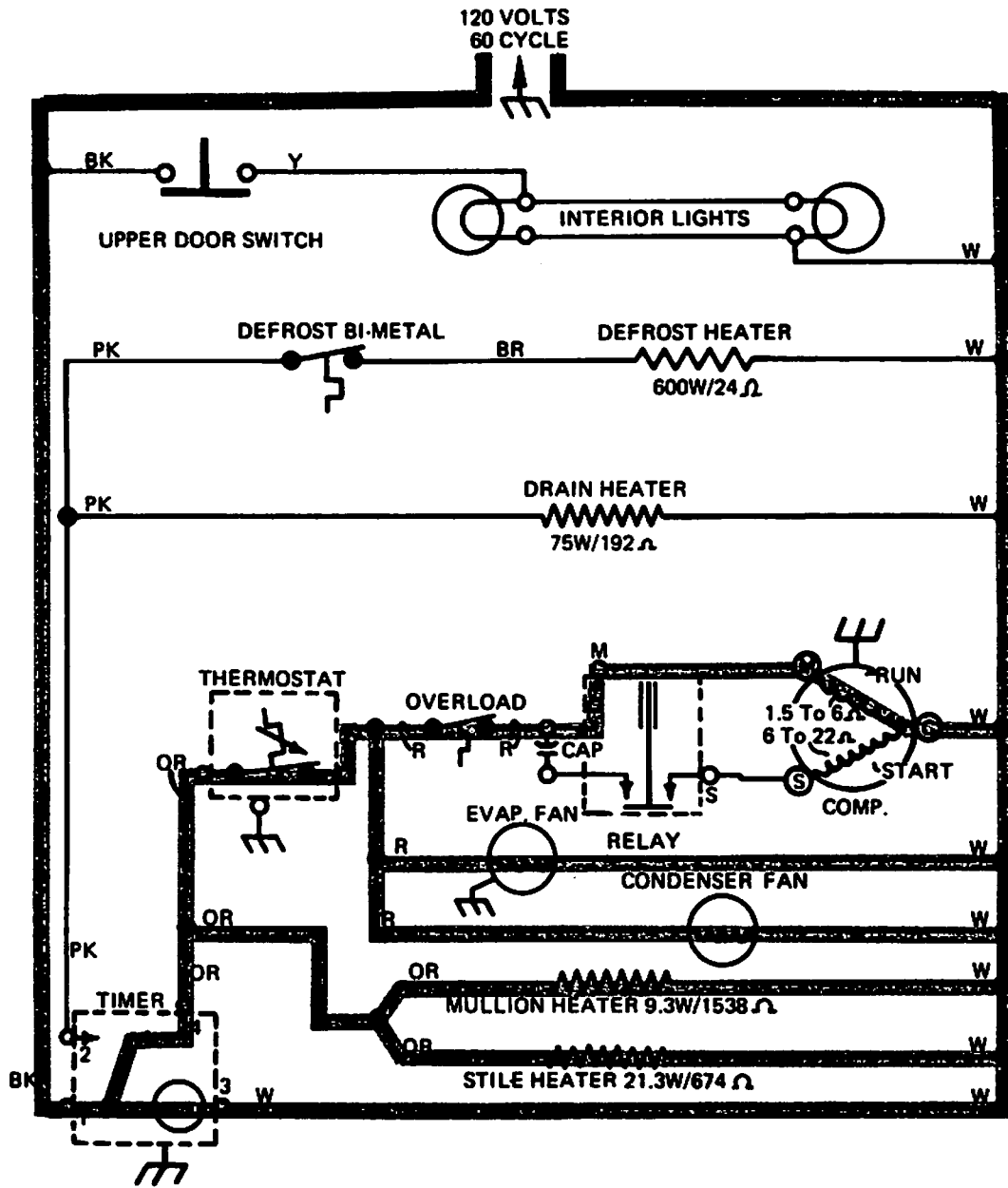

Note the defrost timer in this diagram. It has closed to contact number 2 and the refrigerator is now defrosting. TRACE THE ACTIVE CIRCUITS WITH A WAVY LINE.

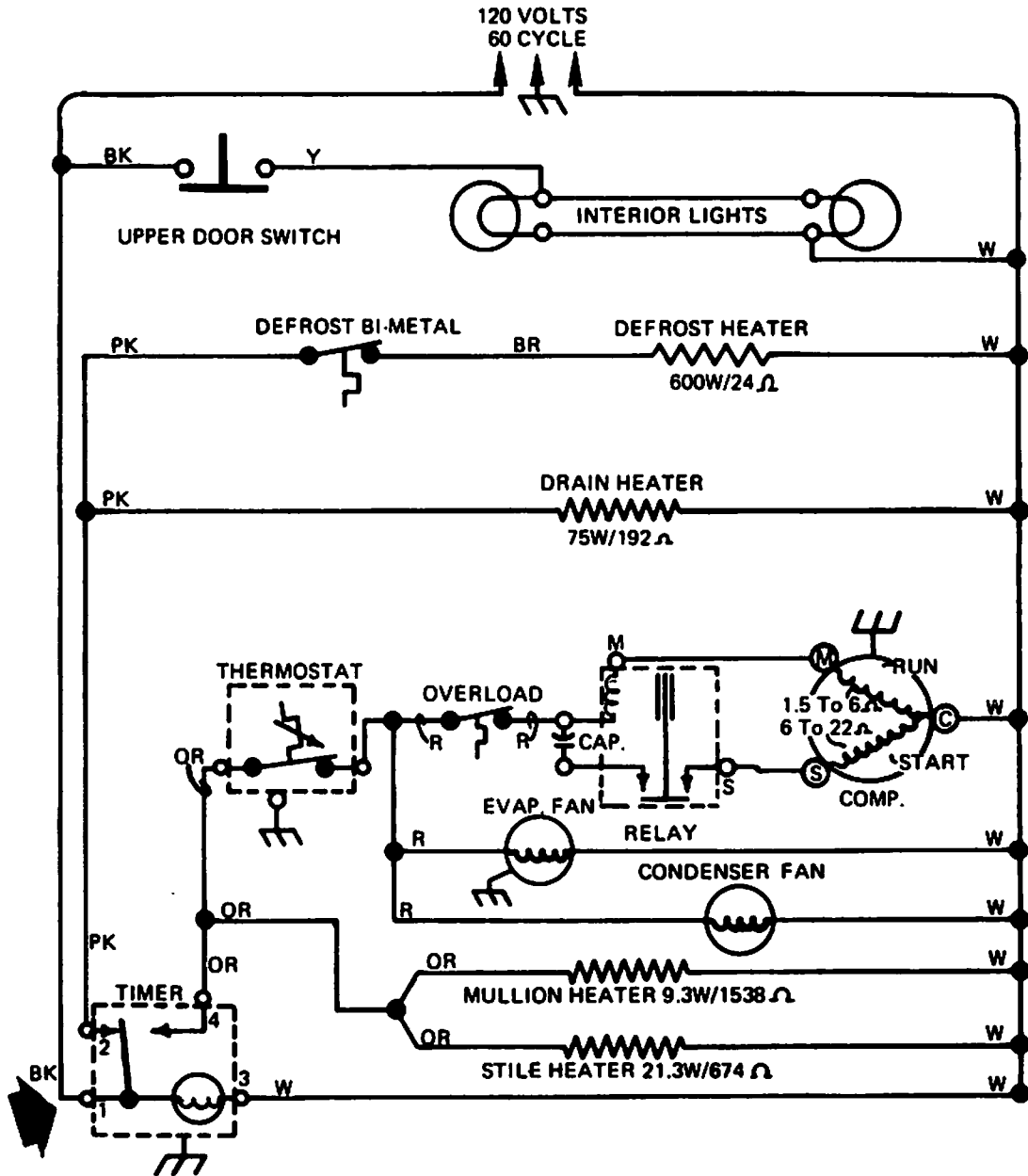

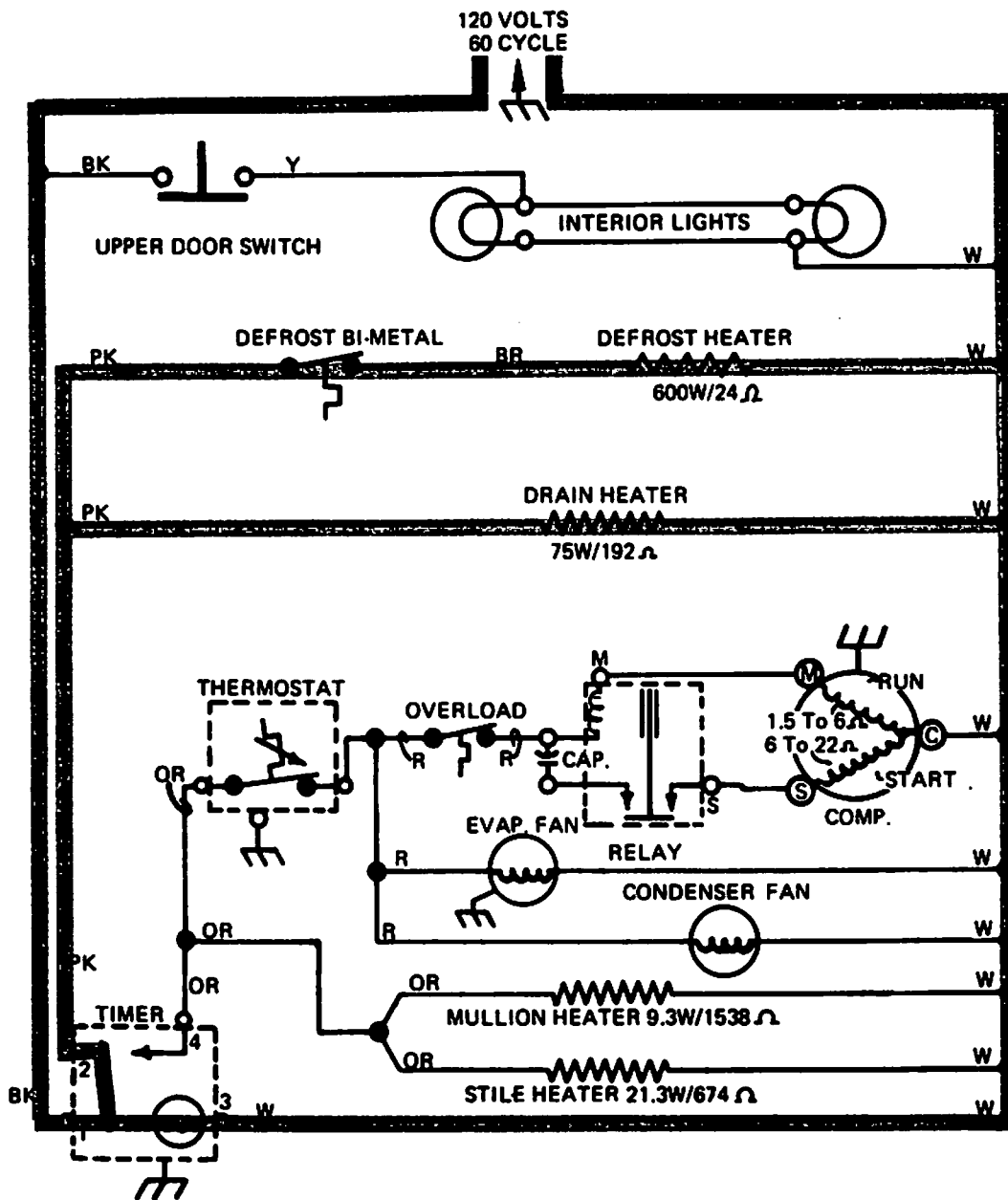

Let's turn our attention to dishwasher wiring diagrams. In the dishwasher wiring diagram below let's assume that the timer has advanced to a fill position and timer switches 2, 3, 5 and 22 are closed. The door is closed and the motor is running. We have closed the contact in the pushbutton selector switch and the push/pull switch for you.

CLOSE TIMER SWITCHES 2, 3, 5, AND 22, AND THE DOOR SWITCH, THEN TRACE THE ACTIVE CIRCUITS WITH A WAVY LINE.

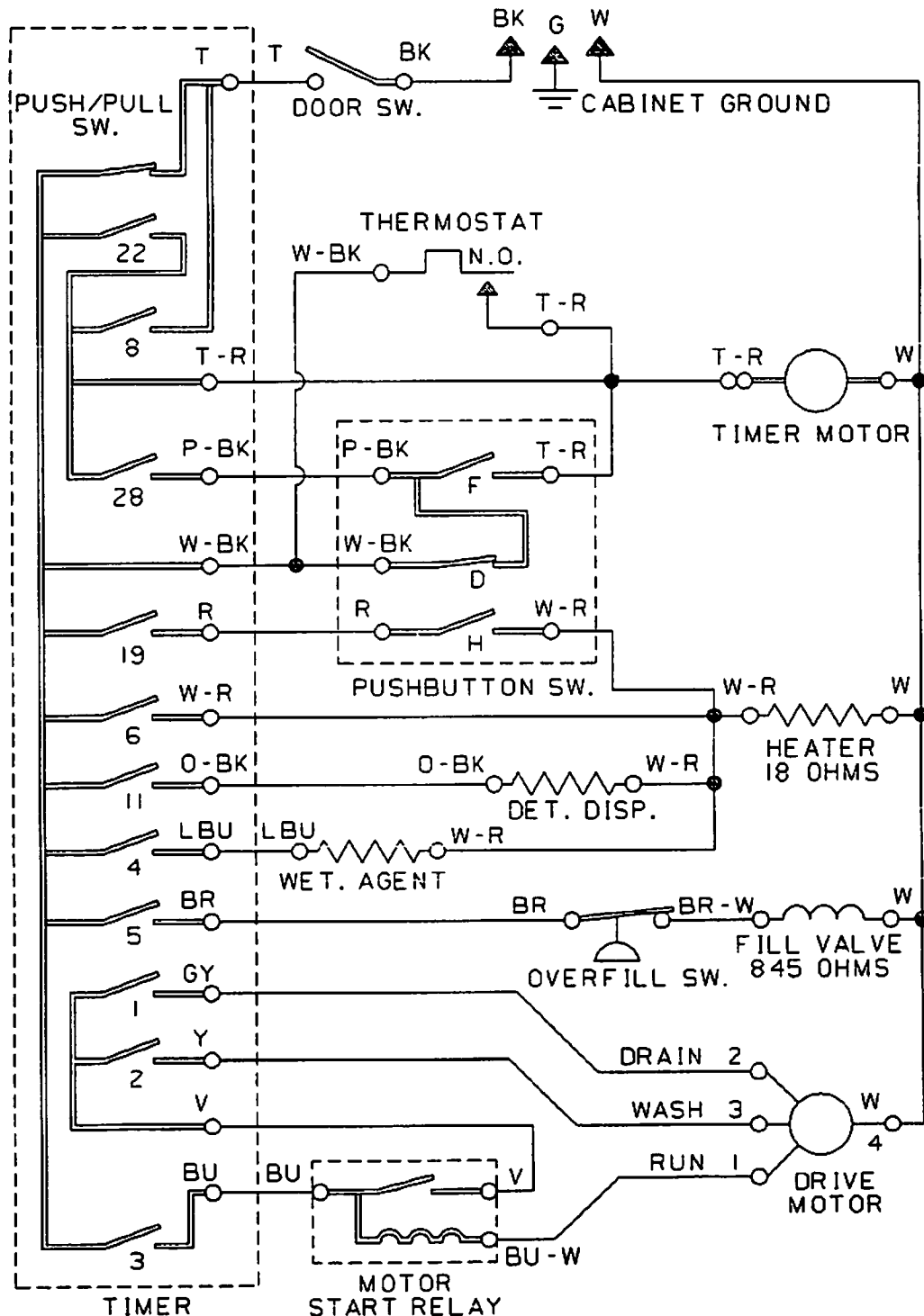

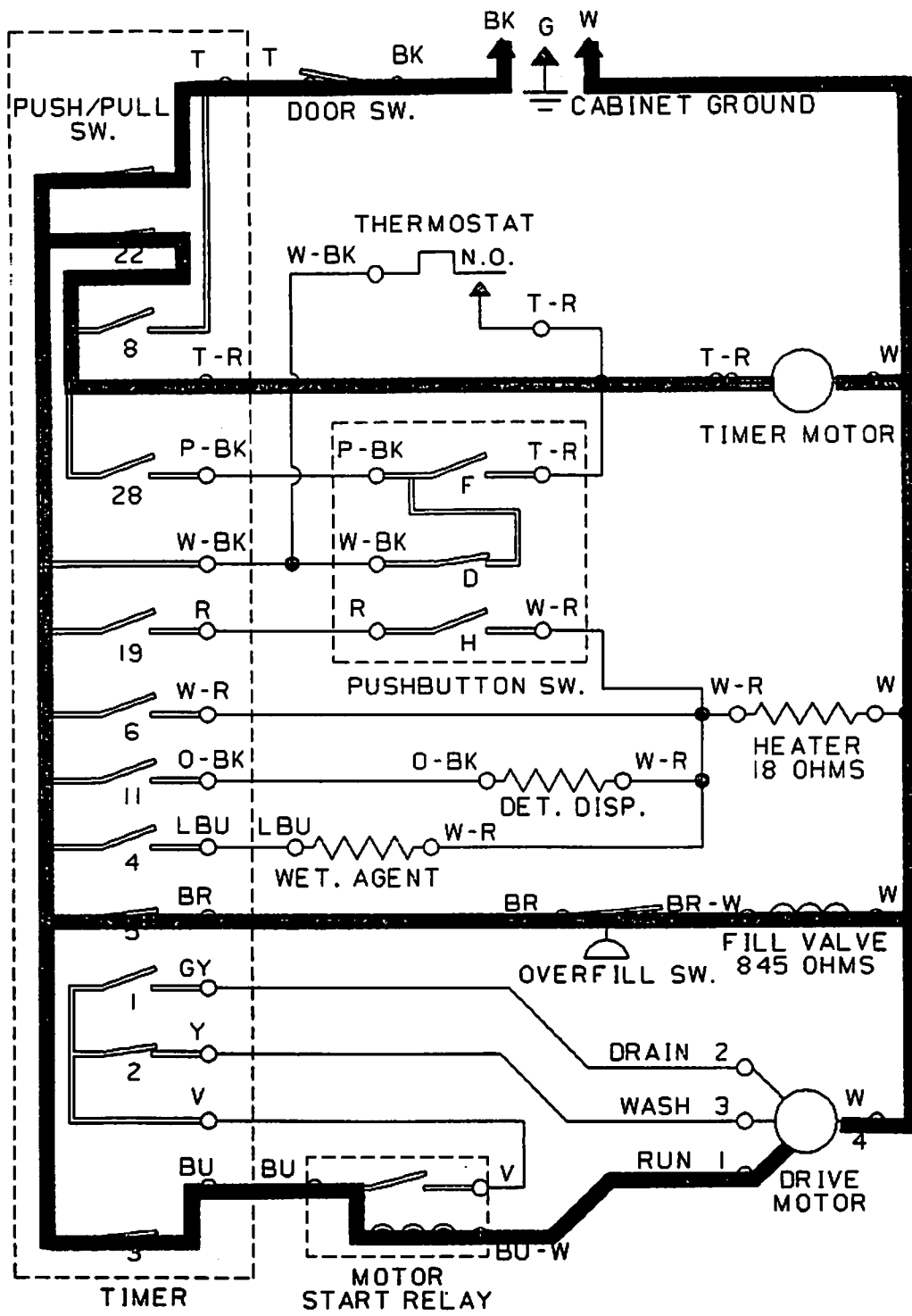

Let's trace the circuits for a "heat dry" cycle. During this cycle the drive motor stops running and timer switches 1, 19 and 22 are closed. Once again, we have closed the contact in the pushbutton selector switch and the push/pull switch for you.

CLOSE TIMER SWITCHES 1, 19 AND 22, AND THE DOOR SWITCH. THEN TRACE THE ACTIVE CIRCUITS WITH A WAVY LINE.

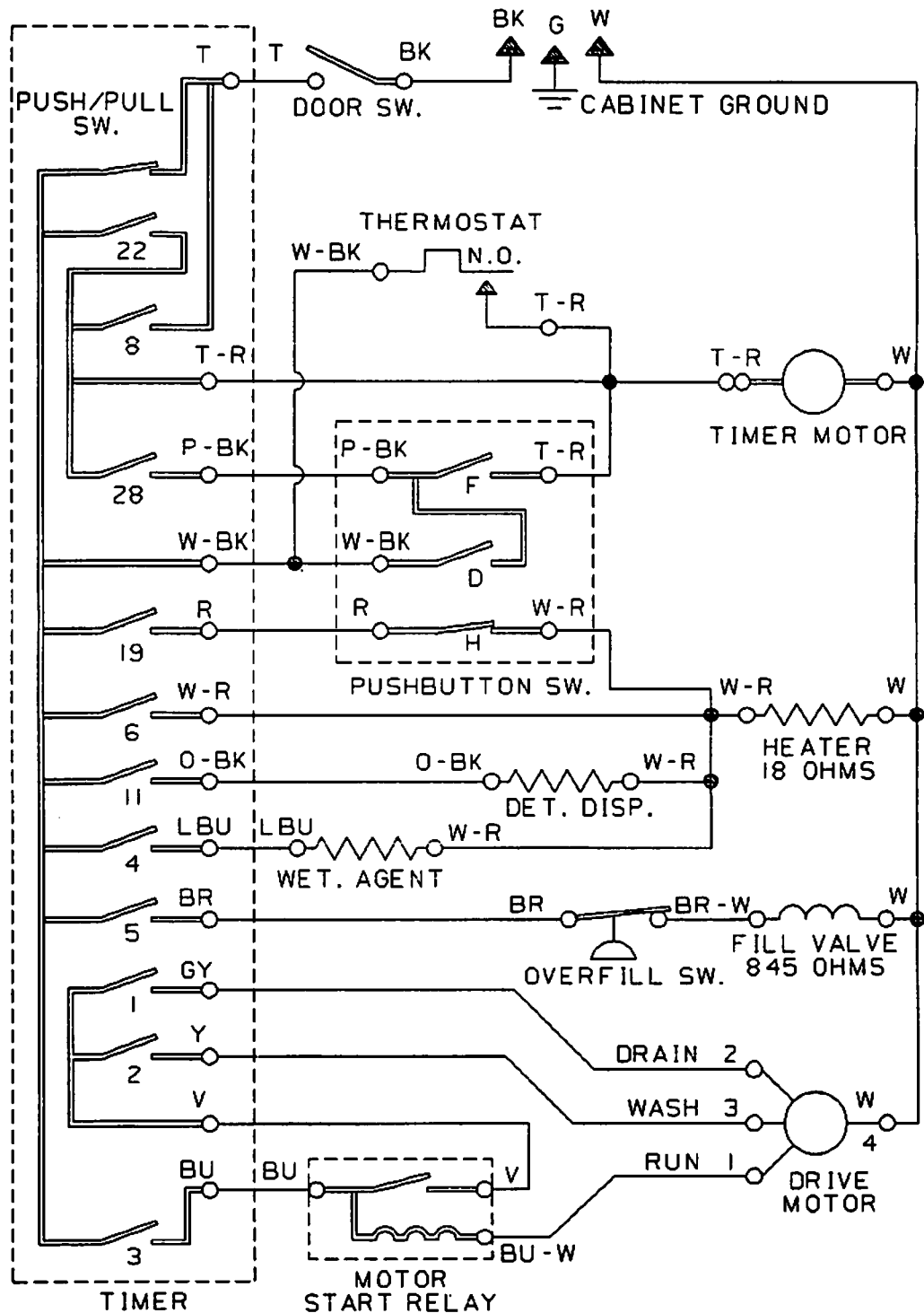

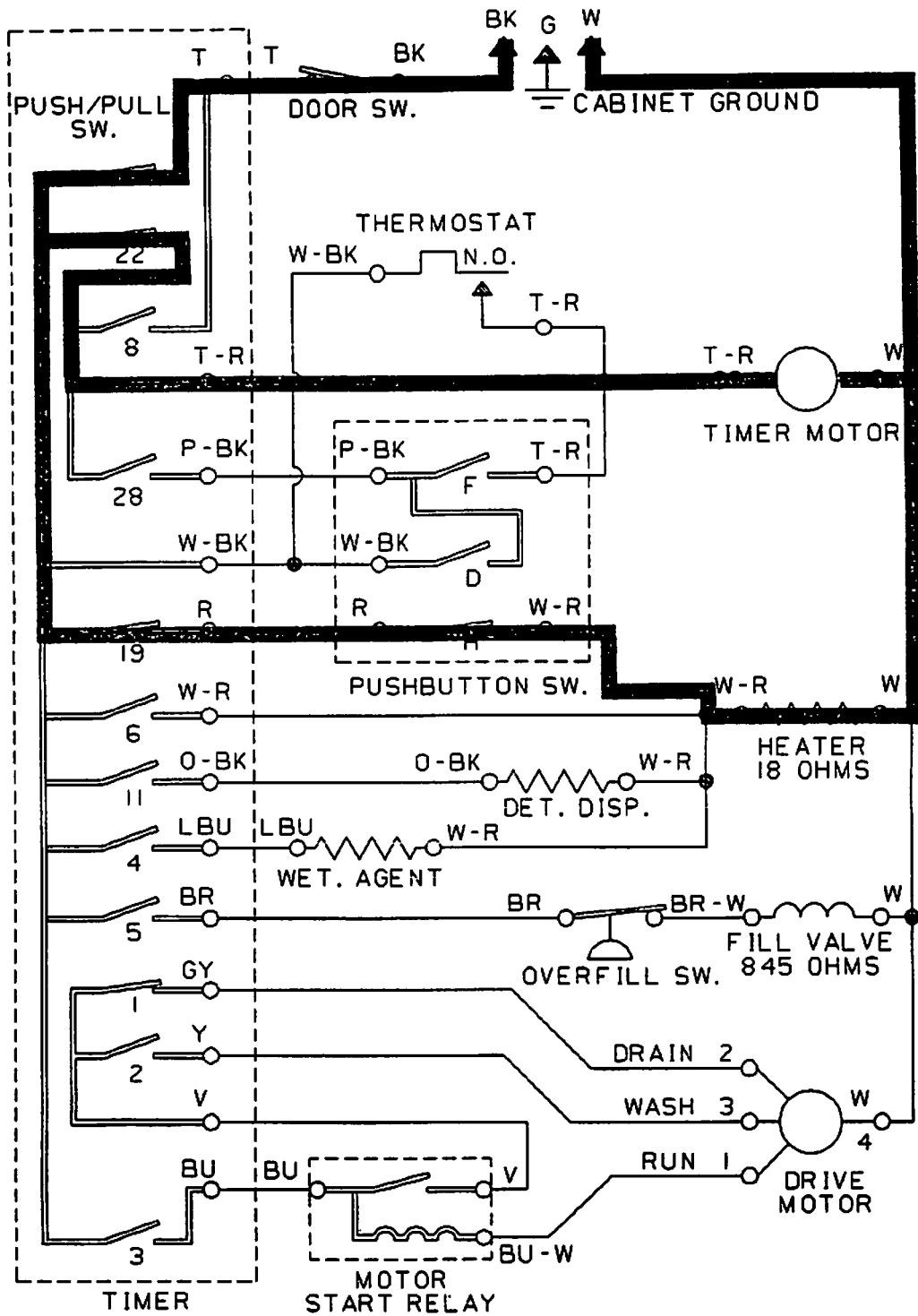

Now we will focus on the microwave oven. The oven cavity light goes "on" whenever the door is opened or the microwave oven is operating. This light goes "OFF" when the microwave oven is off.

The door is closed and the microwave oven is "OFF."

TRACE THE POTENTIAL CIRCUITS WITH A WAVY LINE.

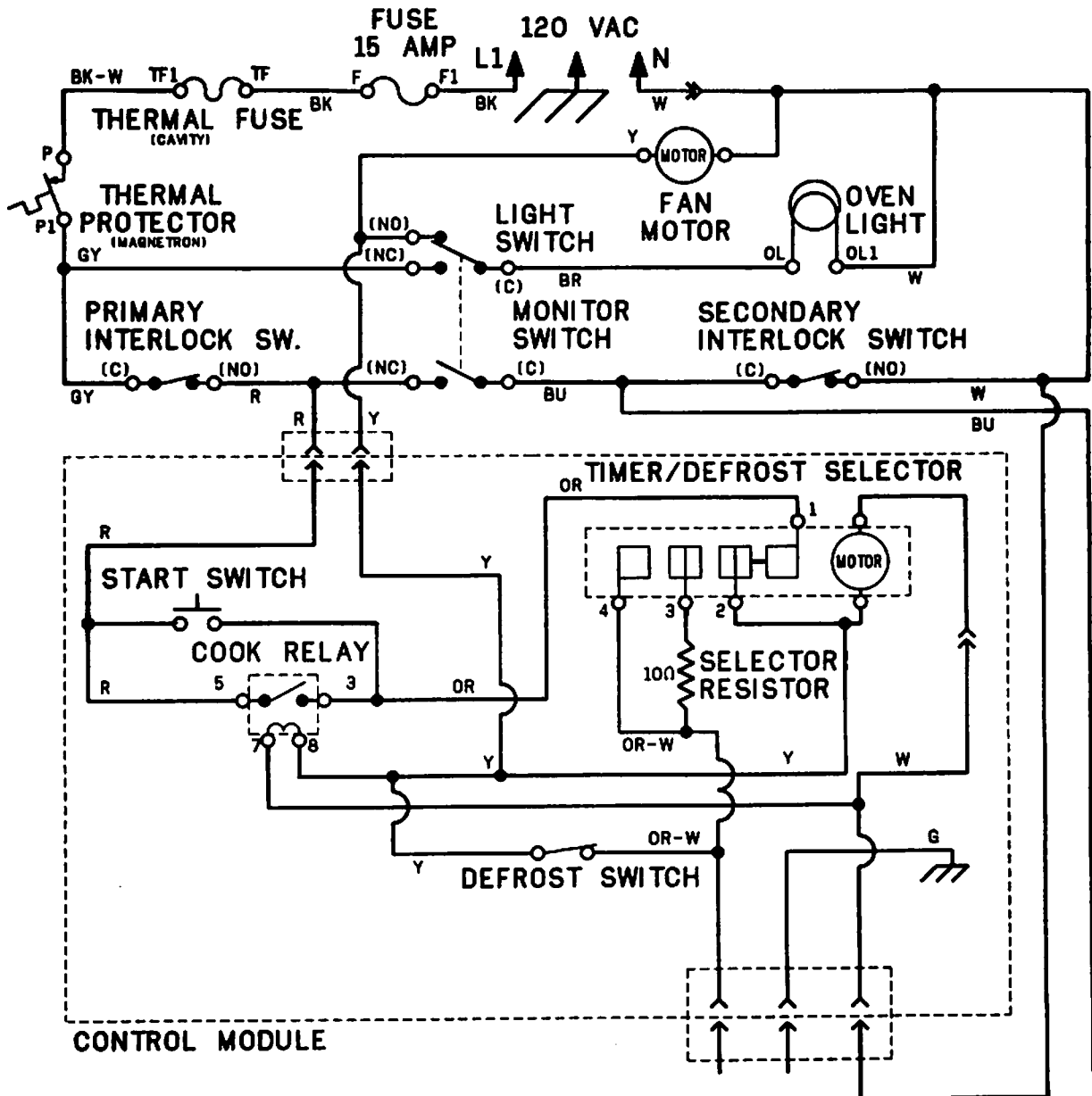

You can see the potential circuit to the start switch.

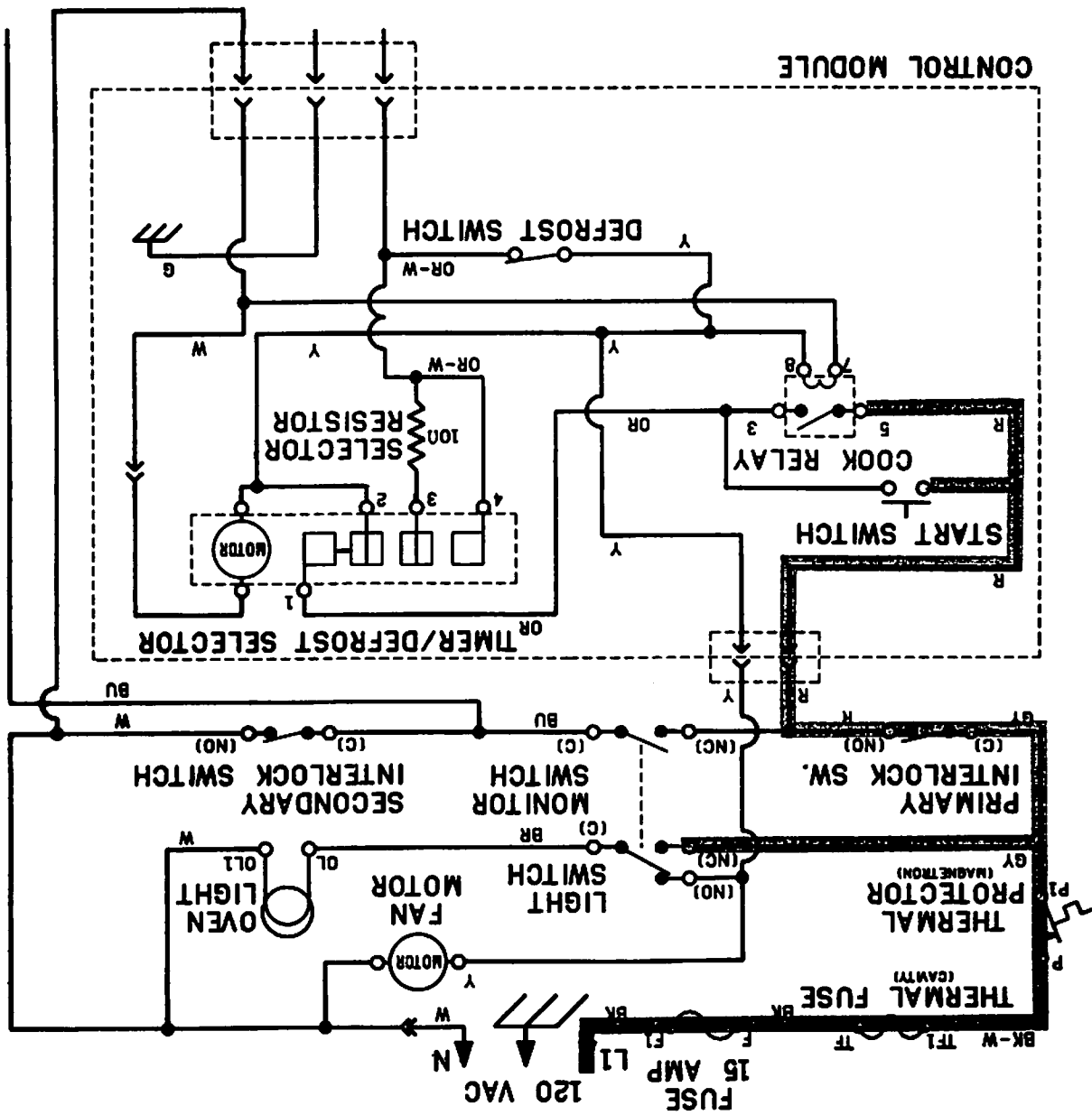

Now, with the door open and the microwave still "OFF," TRACE THE ACTIVE CIRCUITS WITH A WAVY LINE.

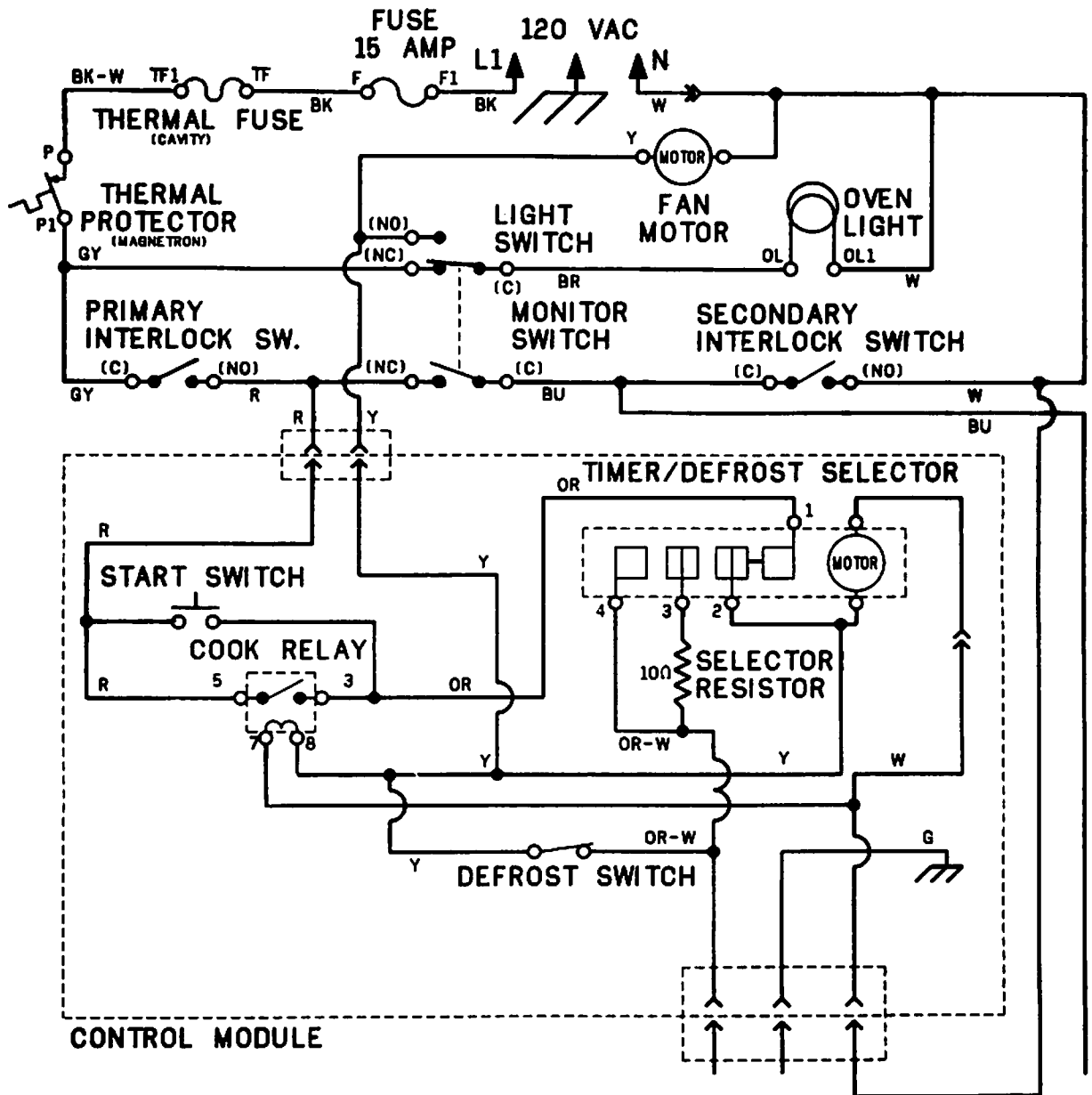

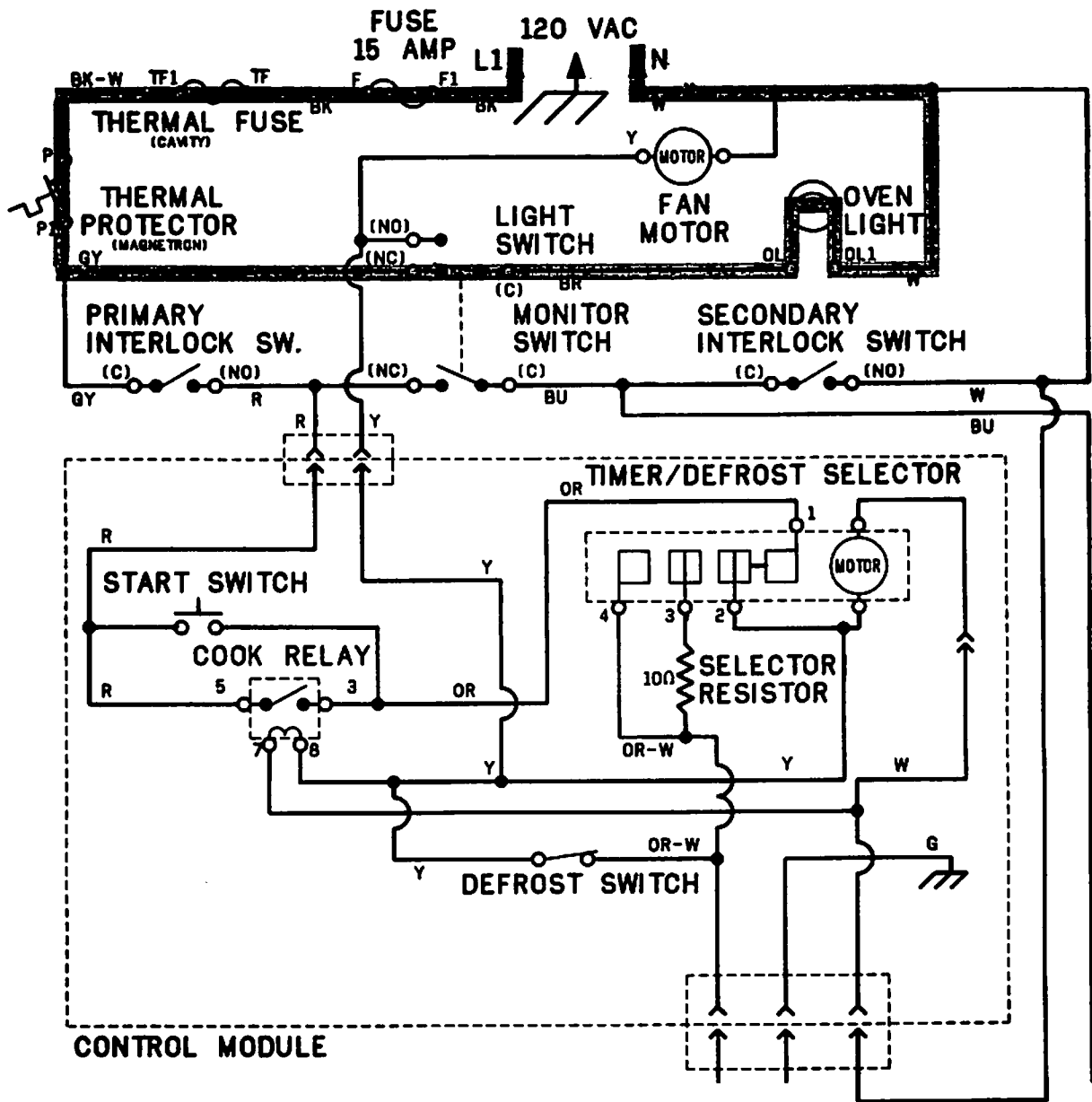

Great! Now with the door shut, turn the microwave "ON." TRACE THE ACTIVE CIRCUITS WITH A WAVY LINE.

Remember, when the Push-To-Start switch is briefly closed, the COOK RELAY is energized.

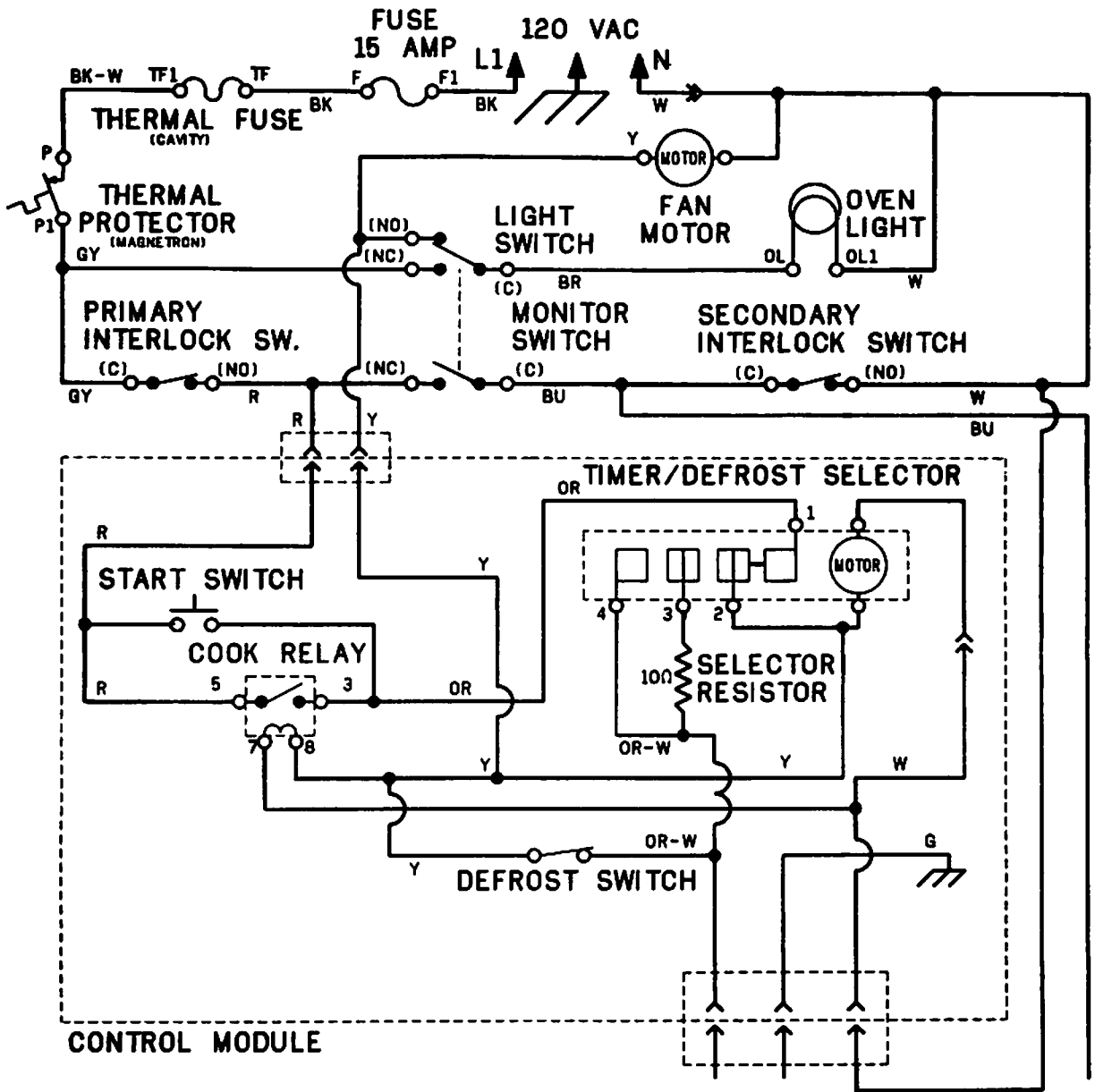

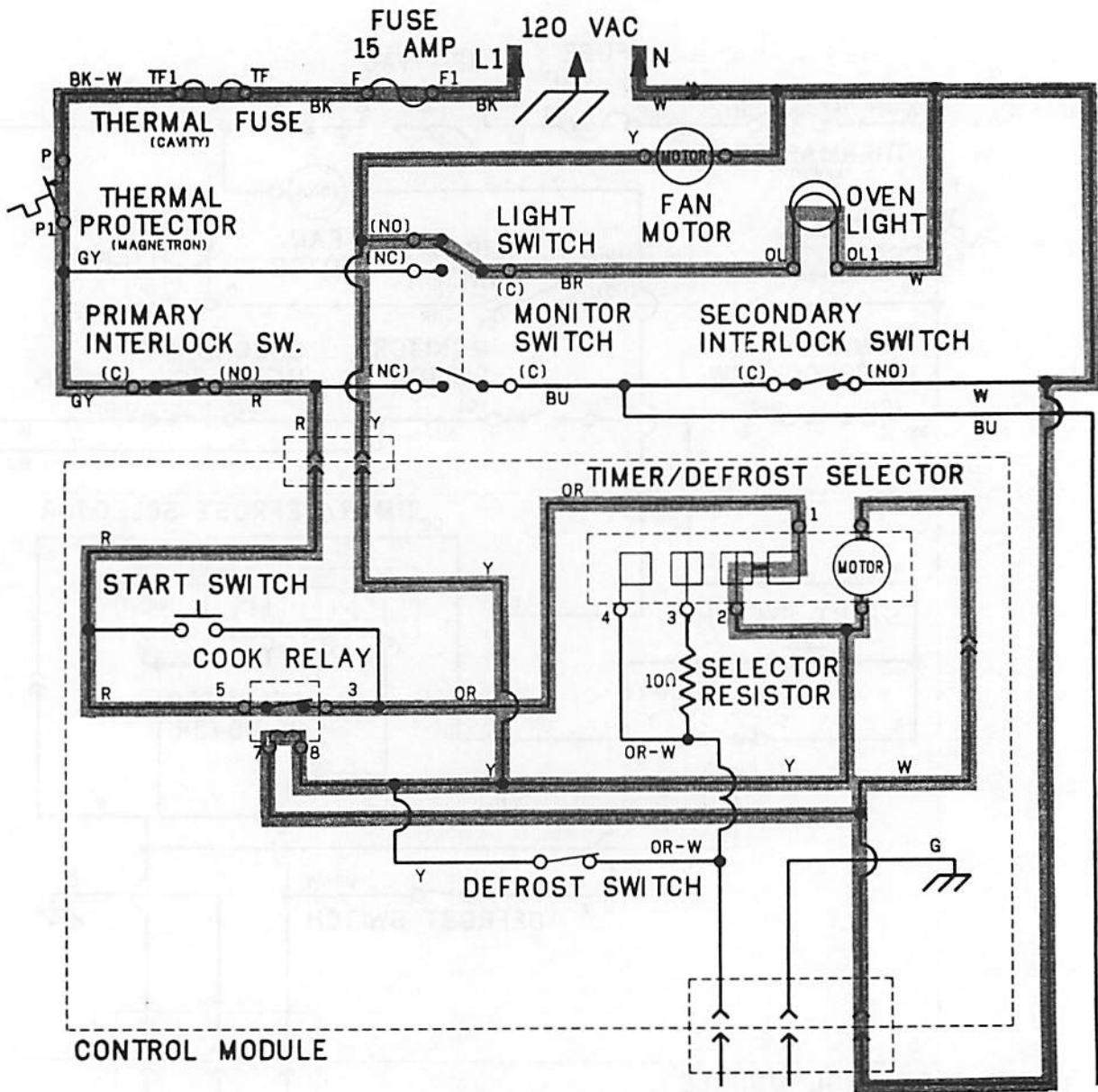

On this page we show symbols for a switch used on an air conditioner.

NOTE: The black dots within the switch indicate a junction, but when a switch function is chosen, all other dots except those on a horizontal line with the chosen function must be ignored.

If the switch is set on HI FAN, the circuit through the switch is:

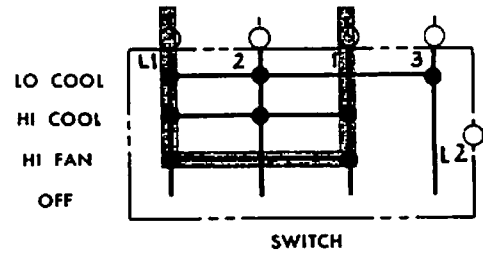

If the switch is set on HI COOL, the circuit through the switch is:
(You draw this one.)

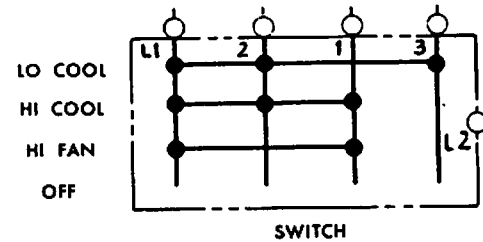

If the switch is set on LO COOL, the circuit through the switch is:
(You draw this one.)

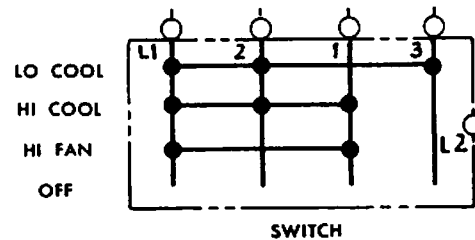

HI COOL

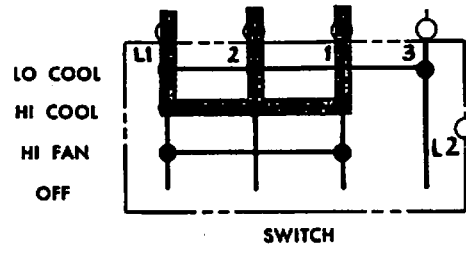

LO COOL

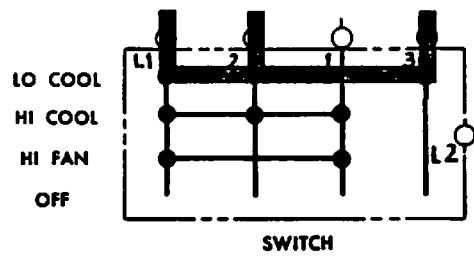

Now that you know how to trace a circuit through the air conditioner switch, we want you to trace out a complete circuit.

MARK A WAVY LINE THROUGH CIRCUITS WHICH ARE ACTIVE WHEN THE SWITCH IS ON THE HI FAN POSITION.

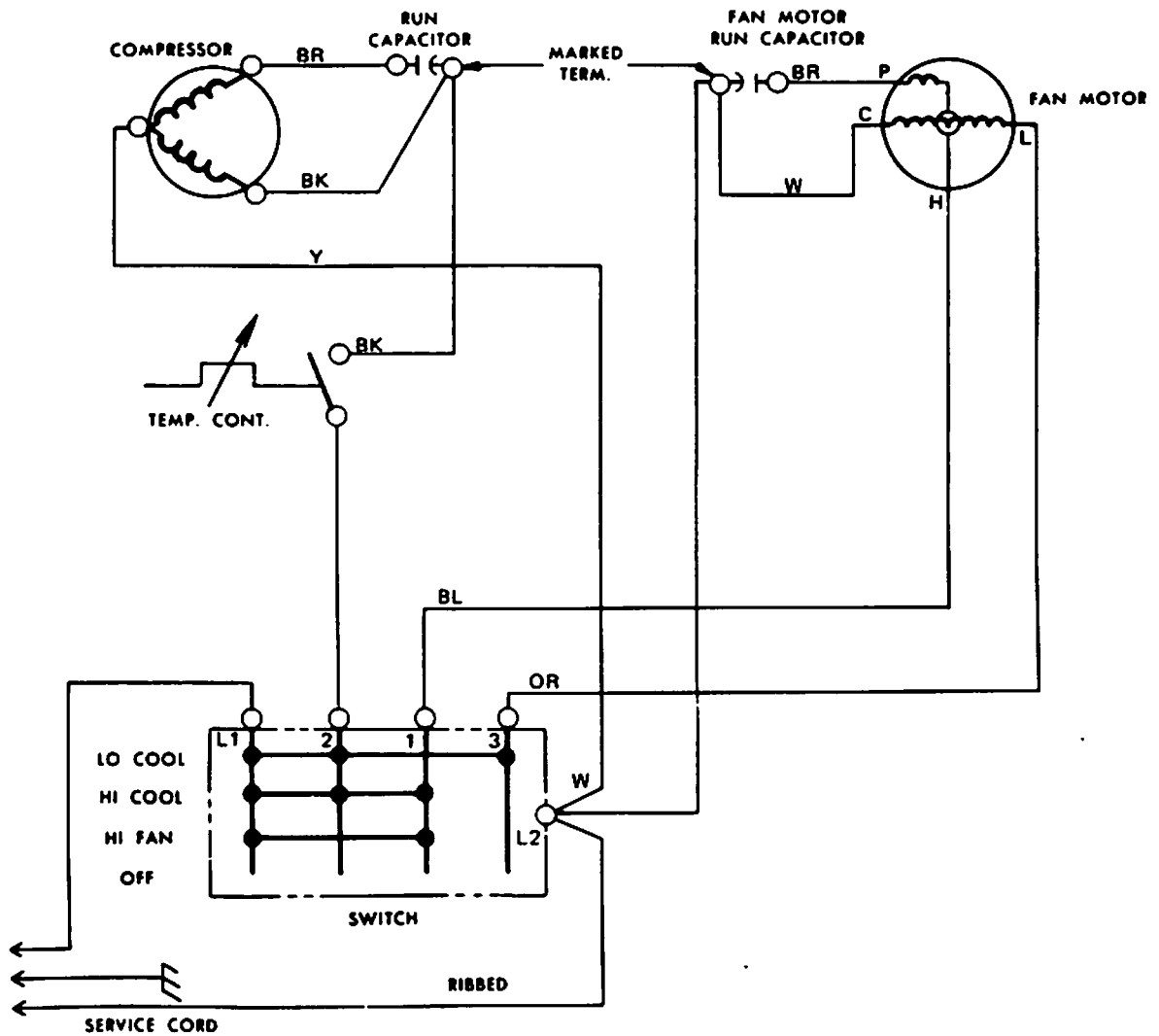

NOTE THE CIRCUIT THROUGH THE FAN MOTOR. DID YOU GET IT RIGHT?

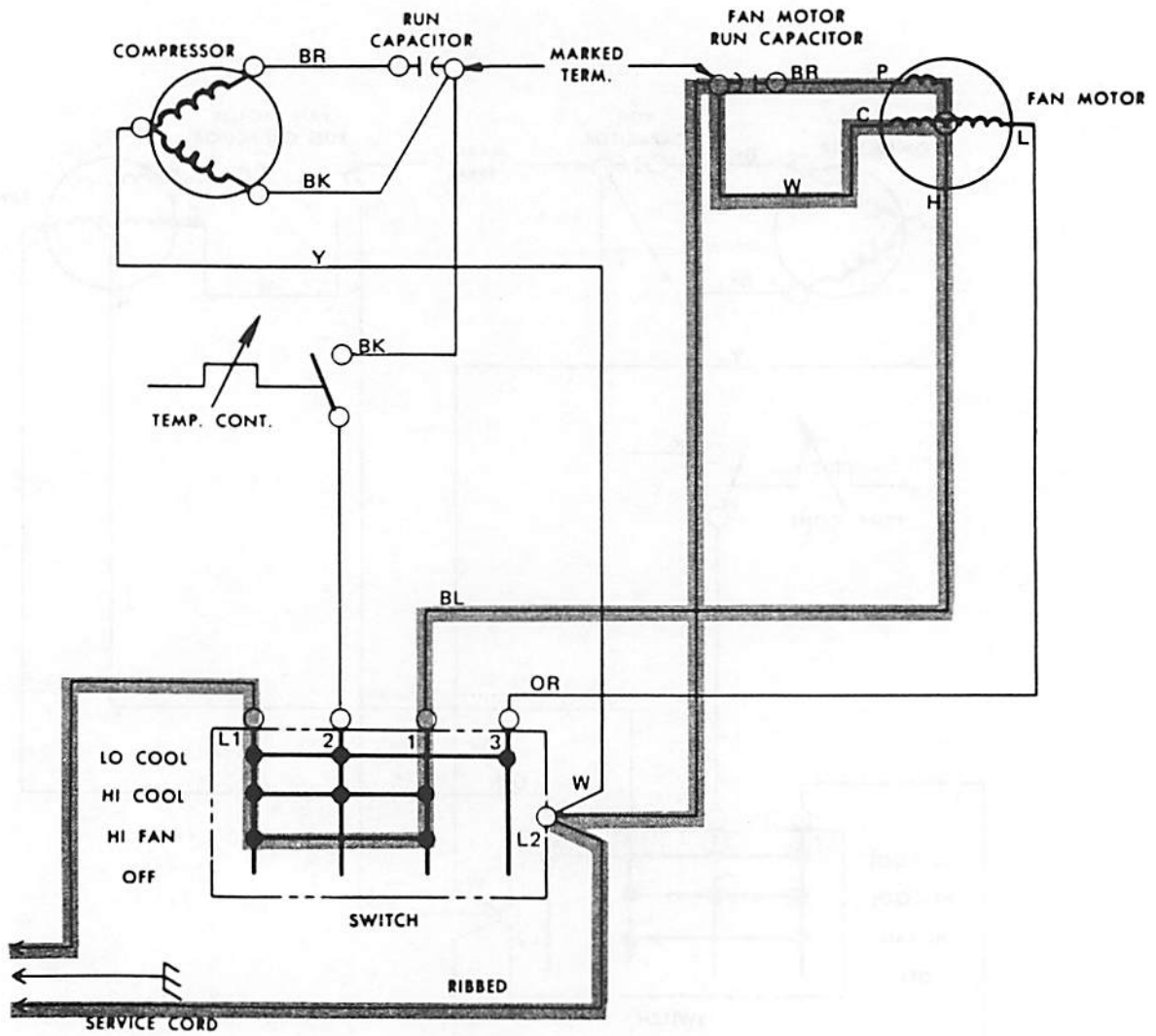

The fan circuit in the HI COOL and the HI FAN positions will be the same. Remember that this air conditioner temperature control switch (thermostat) closes on heat rise.

LET'S CLOSE IT NOW, AND TRACE A WAVY LINE THROUGH ACTIVE CIRCUITS IN THE HI COOL SETTING.

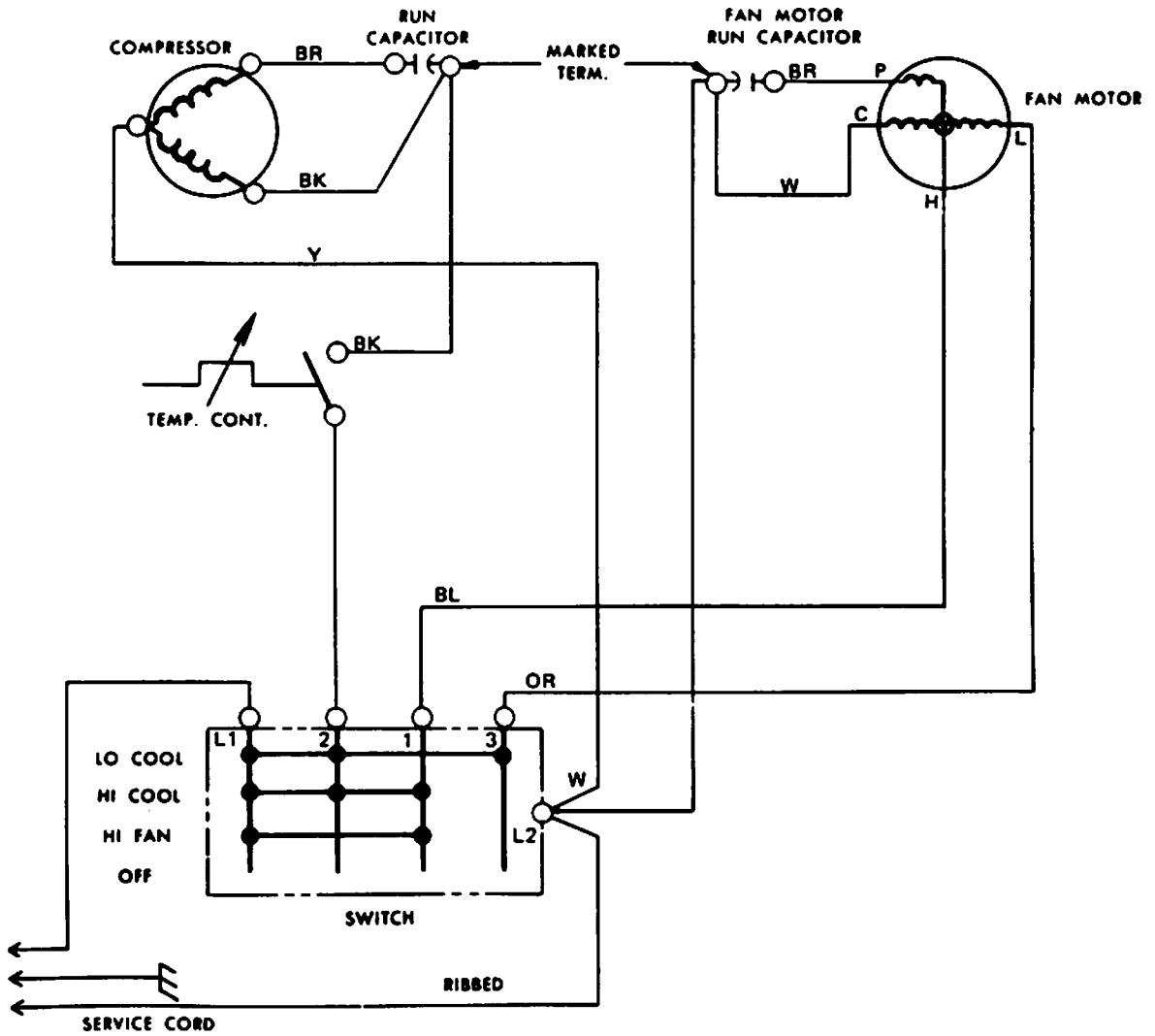

NOTE THAT NEITHER THE COMPRESSOR NOR THE FAN MOTOR USES A STARTING RELAY. THESE MOTORS ARE OF THE PSC (permanent split capacitor) TYPE.

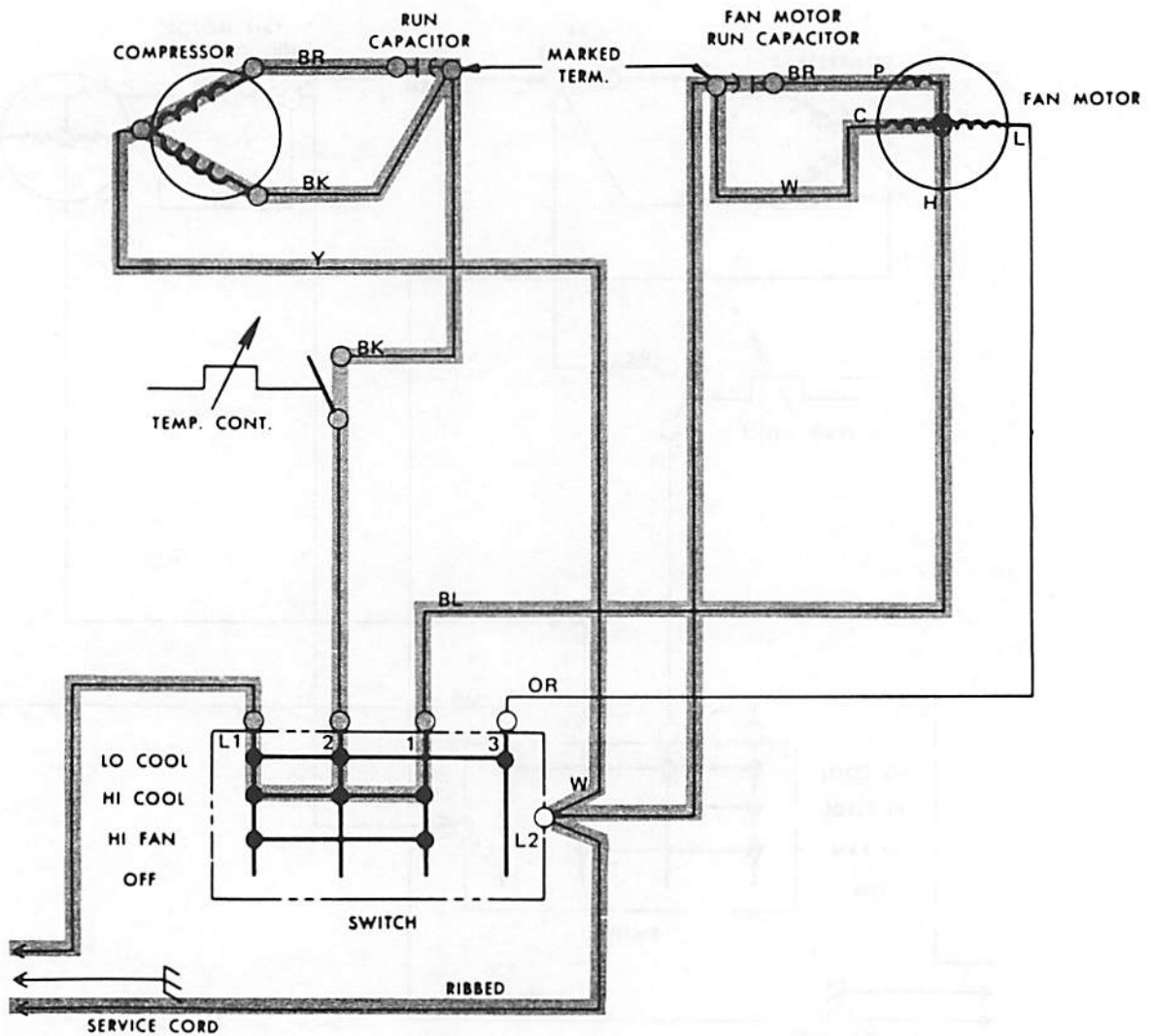

You knew we would want you to trace the LO COOL circuit, too!

CLOSE THE TEMPERATURE CONTROL SWITCH AND TRACE YOUR WAVY LINE THROUGH THE CIRCUITS WHICH ARE ACTIVE ON THE LO COOL POSITION. WATCH CAREFULLY AS YOU TRACE THE CIRCUIT THROUGH THE FAN.

