

May 1, 2018

Chair Kim Travis,  
Milwaukie Planning Commission  
6101 SE Johnson Creek Blvd.  
Milwaukie, OR 97206

**SUBJECT: #CSU-2018-001**

**SITE: MHS Lake Road Sports Complex (2905 SE Lake Rd)**

Dear Chair Travis and Members of the Planning Commission,

3J Consulting has prepared this letter on behalf of the North Clackamas School District in order to provide additional testimony related to several issues raised during the April 24<sup>th</sup> Planning Commission Hearing for the North Clackamas School District's Lake Road Athletic Fields. The following information has been structured to respond to 1) questions raised at the public hearing and 2) issues raised via additional public testimony.

### **Issues Raised during the April 24th Public Hearing:**

During the April 24<sup>th</sup> public hearing, the record was left open in order to allow for the admission of several clarifying comments into the record. The items raised at the Public Hearing specifically sought further comment about the items identified below. Below each of the items, the Applicant has provided a response and extracted images from the site development plans to illustrate the District's intent:

- **Parking Lot Lighting**

**District's Response:**

The District is proposing to provide illumination along one side of the parking lot. The Director has the ability to require more or less parking lot lighting if the need for additional safety is perceived. The District's provision of lighting for the proposed parking area for users of the fields during the spring and summer seasons seems to be adequate. The plans do not provide full coverage within the parking areas, however, they provide a safe level of lighting for users arriving via the Lake Road entrance without over-illuminated a lot which will only be used in season.

The Applicant has included two plans for parking lot lighting and photometric analysis within this submission. These are included as plans 0450E1\_E1 and 0450E3-E3.

- **Netting/Backstop Details**

**District's Response:**

The District is proposing to provide new backstops and netting near the home plates of both new varsity fields. The newly proposed backstops are much higher than the existing backstops. The existing JV field backstop is approximately 16' tall. The new backstop at the varsity softball field will be 30'. The existing varsity baseball backstop is approximately 20' tall. The new backstop will be 30'.

As proposed, the site's geometry will also be changing and should reduce the likelihood of foul balls travelling onto adjoining properties. Home plate on the baseball field will be 136 feet from the north property line at the closest point. The JV Baseball field will be relocated, and softball will be played which should reduce the height of the foul balls from the new softball field. The current varsity field is located approximately 75 feet from private property. Foul balls are now being generated from two locations from the facility. The relocated facility concentrates the hitting areas to one location.



---

The new diagrams for the backstops and netting are included on pages 9.3 VSB ELEV SECTION AND 9.4 VBB ELEV SECTION.

- **Overall Plan for Public Access**

**District's Response:** The District is proposing to gate and lock access to the Milwaukie Elementary School site while school is in session.

The District is proposing to install lockable gates at the 28<sup>th</sup> Avenue parking lot and along Lake Road. The gates will generally be open and will allow for public access to the areas surrounding the new varsity fields. The varsity fields will be gated and locked. The District will allow access to the fields only to authorized users.

- **Lighting and PA System**

**District's Response:** The proposed PA system at the fields will only be available for school district use. Private or Club sport teams using the fields will not have access to the PA system.

The field lighting proposed by the district will be controlled by the District, by the Athletic Director or by authorized representatives who are scheduled to lease the fields. In order to prevent use beyond the hours permitted by the City's Municipal Codes, all field lights will be programmed to automatically shut off at no later than ten pm.

- **Parking Demand**

**District's Response:** The Applicant engaged Lancaster Transportation Engineers to review parking at the site during the games scheduled from April 24<sup>th</sup> through April 30<sup>th</sup>. Lancaster Engineering provided a memorandum summarizing their findings which has been attached hereto. The primary findings of the Lancaster Report were as follows:

Based upon observations, vehicles visiting the fields are currently parking off-site, primarily within the neighborhoods south of the fields.

Parking does not appear to be happening with regularity at the Elementary School or the High School.

The District's improvement of a pedestrian pathway from Milwaukie Elementary to the varsity fields should make the prospect of parking at MES much more appealing for users and this will likely reduce the number of users parking off-site on neighboring local streets.

The District should focus on educating users about where over-flow parking is most appropriate – at MES and at the High School.

- **Emergency Access**

**District's Response:** The proposed site improvements will enhance emergency access. The new turnaround will provide a place for fire trucks to turn around. The site also allows provisions for an ambulance to access the fields. The Applicant has submitted plan NCS30 to illustrate the available turning radius within the proposed parking area.



- **The pros and cons of natural and artificial turf:**

**District's Response:** In 2016, the District passed a \$433 million bond based on a list of commitments that each school in our district would receive as a result. The district's residents voted and the District is committed to including turf fields for both Varsity Baseball and Softball at each comprehensive high schools.

The biggest benefit of having artificial turf for baseball/softball and Oregon is the weather. The artificial turf provides the opportunity to play home games for the student athletes at Milwaukie High School. It also allows practice time on the field in February when the season officially starts.

Field preparation of a natural grass and dirt baseball field and softball field is intensive. Rainouts can be common, and it can take many days of sunshine to dry out a field. Once dry, the field must be dragged, raked and chalked. Teams travel to the site, only to have a rain shower postpone or cancel the game. It presents a scheduling challenge for athletic directors in the area.

Artificial turf has been proven to be very popular in the area. Colleges such as Oregon State, Oregon, University of Portland, Linfield College, and George Fox all have artificial turf baseball fields. Lake Oswego and West Linn have used turf fields for many years.

Clackamas High School baseball has an existing turf infield which was installed in 2013/14, and turf infields will be installed on the varsity softball field at Clackamas as well as on both the varsity baseball and softball fields at Putnam.

As an example, back in 2008, Clackamas High School's varsity baseball team played one home game on their natural grass infield. Last year, even when it rained, they did not have a rainout because of the artificial turf.

- **A description of the baseball and soccer coach's preference regarding artificial vs. natural turf. (NCSD)**

**District's Response:** After consulting with the Athletic Director and the District's coaching staff, the general preference is for artificial turf based upon the playability during incimate weather. A survey of the professional and former collegiate athletes employed at both HHPR and 3J Consulting resulted in a unanimous preference for artificial turf fields during raining conditions.

**Response to Additional Public Comments:**

The following is a summary of the issues raised within additional public comments received by the Applicant following the hearing and the District's responses to each of the comments:

- **How many games are likely to be played simultaneously?**



**District's Response:** No more than two games would ever happen simultaneously -- one on each of the Varsity fields. It would probably only happen 2-3 times per month during the spring baseball season (late March through mid-May). It could be possible that different teams would be using the fields for practices or drills (without hitting balls). In that case, there would be no spectators.

- **What is the capacity for the proposed bleachers?**

**District's Response:** The bleachers at the Varsity Softball and the Varsity Baseball field offer 200 fixed seats.

- **Can we provide a clear diagram of the Artificial and Non-artificial turf fields?**

**District's Response:** The attached Site Plan illustrates the artificial and non-artificial turf areas.

- **The District's parking comparisons to other sites need to be Apples to Apples – this is not an open large site, rather an urban campus.**

**District's Response:** The parking analysis provided by the Applicant includes parking ratios from the City of Portland specifically because Portland has many infill sports facilities which are located in urban, established neighborhoods.

- **The District needs to provide more parking. Several photos of the neighborhood in the record show cars parked on neighboring streets including one photo of a car parked in front of a fire hydrant.**

**District's Response:** Parking in front of a fire hydrant is a police matter and is not endorsed by the District. The District's proposal includes a plan to provide better linkage between the parking lot at Milwaukie Elementary School and the site. As mentioned previously in this letter, the District plans to help educate users of the fields to avoid parking off-site wherever possible and to use either the Elementary School parking lot or the High School Parking lot to access the fields.

- **Stated that the EPA is conducting a test on recycled tire crumb use on play fields. The study is expected to be released in mid-2018. Patti suggests that the Commission should wait until after the EPA releases study to allow this project to move forward.**

**District's Response:** Regarding the toxicity of the artificial turf, the District has coordinated with the manufacturers and installers of the artificial turf and has solicited the following responses:

**Turf:**

There is no specific code requirement which addresses these issues. The District previously provided links to a Penn State study by Bleyer and Keegan in 2018 which compared rates of cancer in 58 counties in California with varying synthetic turf density, the study concluded that "consistent with those of a prior study observing no association between individual-level exposures to turf fields and cancer incidence. Avoidance of synthetic turf fields for fear of increased cancer is not warranted."



**Turf Chemical Concerns:**

The installation of artificial turf will eliminate the use of fertilizer and pesticides which is a benefit to water quality.

The crumb rubber will be one element used within infill for the field, and sand will be the other mixture. A 10" sand and gravel base will be constructed with the field, providing an opportunity to filter runoff. The design of the turf system does not allow the crumb rubber an opportunity to migrate into the base, however, if this did happen, all storm lines are wrapped with filter fabric, and a filter fabric will also be installed on the subgrade providing redundancy to eliminate any chance of migration of solid crumb rubber.

**Turf Climate Change Concerns:**

The District notes that the proposed turf does use recycled materials and eliminates the need to maintain a grass field and dirt infield. Over an estimated 10-year life of the turf, the field could potentially be mowed 520 times if it remained as natural grass. A dirt infield also needs maintenance such as the use of chemicals to dry the infield, equipment to drag and groom the infield, and water to keep the dust down in the summer months.

The synthetic turf also eliminates the need for water usage for irrigation and eliminates the need for fertilizers. While the turf field may be hotter on the field than the actual temperature in the shade, it is not uncommon to other surfaces within an urban growth boundary, and the project does maintain a nice landscape buffer around the fields to provide shade.

- **Can the district clarify who will manage the field? Who will deal with rule violations, foul ball issues/damages and conflicts which may arise during games.**

**District's Response:**

The District will continue to manage the fields and offer access to athletic teams and authorized sports organizations. The District will respond to all inquiries and pretensions for repairs necessary to address damages caused by foul balls. As required by the District's current field rental policies (described in document KG R 1 D1), the District requires any users to maintain insurance with general liability for damages arising from the use of the facilities.

- **Can the district provide a full list of current contracts for use of the fields by club sports or other non-school related community athletic groups?**

**District's Response:**

To provide clarification on the District's decision making for assignment of the fields to non-school related users, the District has provided the attached *Community Use and Rental of District Facilities* documentation. Within this document, the District's policies on use of school facilities is outlined, as are the District's prioritization guidelines for assigning field time to various organizations. As described within the document, Partnering Organizations and local youth organizations with over 90 percent North Clackamas youth are given first priority. Out-of-district youth organizations, adult leagues, civic/service groups and public agencies are given second priority. Private interest or for-profit organizations are given last priority.

The District's current field users include:



Varsity Baseball

- Spring Practices and Games
- Weeknights and Weekends

Varsity Softball

- Spring Practices and Games
- Weeknights and Weekends

JV Baseball

- Spring Practices and Games
- Weeknights and Weekends

Mustang Boys and Girls Soccer

- Sunday through Monday Practices and Games
- July through October

Oregon City Youth Football & Milwaukie Youth Football

- Youth Football clubs will only use Lake while the stadium is under construction or while Aldercreek is unavailable

La Amistad Futbol Club – Youth Soccer Club

- Weeknight and Weekend Games
- September thru December

Central Catholic High School

- Occasional Users

Thelo United – Youth Soccer Club

- Weeknight and Weekend Games
- September thru December

Global Premier Soccer

- Weekend and Weeknight Games
- September thru December

During construction of the MHS stadium, several of the users of the fields will go back to the High School Stadium. Baseball, softball, and soccer will be the primary users once all construction work is complete.

- **Can the district provide a complete list of contracts with anticipated users (club sports, youth baseball/football, and other non-school athletics)?**

**District's Response:** The District's list of potential users is very similar to the existing list of users. The district would be speculating to assume that a significant number of users or teams would be utilizing the fields.

**Requested Changes to Conditions of Approval**



As a reminder, the District has asked for modifications to the Staff report and Conditions of Approval for the Community Service Use Application. While the majority of proposed conditions of approval are acceptable, due to several concerns about the project's safety and budget, the District specifically requests the removal of the following conditions of approval:

**Condition 1.c.3**

As per Finding 6-c, revise the plans to provide a 5-ft-wide sidewalk connection along the driveway between Lake Road and the proposed parking lot sidewalk that meets the standards of MMC Subsection 19.606.3.D, including curb and gutter along the driveway between Lake Road and the proposed parking lot sidewalk. The sidewalk may be on either the east or the west side of the driveway; if on the west side, a marked crosswalk shall be provided to connect the required sidewalk with the proposed sidewalk on the east side of the driveway.

**District's  
Response:**

The District requests that the Planning Commission remove this proposed condition of approval from the decision. The District is not proposing to make significant changes to the existing access drive to the site from SE Lake Road. This access drive falls within the area listed as 28<sup>th</sup> Avenue however, this part of the site is not a public right-of-way, only an existing driveway.

The primary route for student circulation to the fields is through the Milwaukie Elementary School site as this is the most direct and convenient route to the fields from the High School.

In recognition of the need to keep pedestrians safe and to separate them from traffic, the District is comfortable accepting a condition which would require the District to clearly stripe a pedestrian access way and crosswalk within the existing Lake Road/28<sup>th</sup> Avenue access route to the fields. The requirement to provide a new sidewalk along the driveway is not necessary to maintain pedestrian safety and it will almost certainly trigger additional site development costs and significant design considerations for stormwater management.

The District is happy to work with neighboring property owners throughout this process regarding any concerns related to stormwater management and/or run-off. The District will accept a condition of approval requiring the District to coordinate with neighboring property owners and to make improvements consistent with Oregon's Drainage Laws. As currently proposed, the imposition of this condition will add a curb to an existing driveway and additional impervious areas therefore requiring a series of potentially costly and unbudgeted stormwater management improvements.

The District is permitted under Oregon's drainage laws to discharge water onto neighboring properties consistent with the State's requirements. That said, if there are problems arising from the Discharge of stormwater or natural drainage patterns, the District is willing to work with neighboring property owners to try to implement solutions to these issues prior to the finalization of the construction plans for the fields. The City is permitted, through MMC Subsection, 19.606.3.E, to require the imposition of conditions of approval to provide "pavement markings" for pedestrian, bicycle, and vehicular circulation to ensure safe and efficient on-site circulation. The Planning Commission can therefore find that a marked walkway and a new marked crosswalk within the existing driveway meets the City's standards.



---

**Condition 1.c.4**

As per Finding 8-e, revise the plans to provide a pedestrian connection to the public right-of-way at 30<sup>th</sup> Avenue and/or 31<sup>st</sup> Avenue, sufficient to meet the applicable standards of MMC Subsection 19.504.9.

**District's Request:** During the public hearing, an abundance of testimony was offered in support of not creating pedestrian connections between the site and 30<sup>th</sup> or 31<sup>st</sup> Avenue. Based upon this testimony, the District maintains that this condition of approval should be removed to align with the neighbor's desires to discourage event and game parking within the neighborhoods surrounding the fields.

The Commission can find that the requirements of Subsection 19.504.9 have been met without the imposition of this condition of approval.

**Condition 2.a**

Demonstrate that the pedestrian improvements required by Condition 1-c(2) and 1-c(4) have been completed.

**District's Response:** The Applicant requests removal of condition 1-c(4). This condition should be removed to reflect this change.

**Condition 2.b**

Demonstrate that the Lake Road driveway has been improved with a sidewalk as required by Condition 1-c(3).

**District's Response:** The Applicant requests removal of condition 1-c(3). This condition should be removed to reflect this change.

In summary, our office and the District very much appreciate the public's interest and concerns in the improvements proposed at the Lake Road Athletic Facility. We trust that these additional explanations of the field's use and the additional responses placed into the record will help clarify the District's intent and plans for improvement of this critical facility. We look forward to discussing this matter in person at the planned May 8<sup>th</sup> Public Hearing.

Sincerely,



Andrew Tull  
Principal Planner  
3J Consulting, Inc.

copy: Mr. David Hobbs – North Clackamas School District  
Mr. Marc Bargenda – Heery International  
Mr. Dan Houf, HHPR





# Technical Memorandum



**LANCASTER  
ENGINEERING**

**To:** Andrew Tull  
**From:** Jessica Hajar  
Miranda Wells, PE  
**Date:** April 30, 2018  
**Subject:** Athletic Field Parking

321 SW 4th Ave., Suite 400  
Portland, OR 97204  
phone: 503.248.0313  
fax: 503.248.9251  
lancasterengineering.com

This memorandum outlines the existing parking patterns for the athletic fields that serve Milwaukie High School in Milwaukie, Oregon, in order to determine how the proposed parking supply will alleviate any overflow parking within the surrounding neighborhood.

## *Project Description*

The athletic fields are located southeast of Milwaukie High School (see Figure 1). The fields are bordered by SE Lake Road on the south, SE 27<sup>th</sup> Avenue on the west, and SE 32<sup>nd</sup> Avenue on the east.

Figure 1 - Aerial view of site and immediate vicinity (image from Google Maps)



Per the notes on the Master Plan, the parking lot that serves the athletic fields will remain in the same location with some upgrades including: sidewalks, curbs, a turnaround area sized to accommodate a school



April 30, 2018  
Page 2 of 6

bus turning radius, and additional parking spaces. The parking will include 16 new parking spaces for a total of 54 with an additional 43 parking spaces at Milwaukie Elementary School athletic field area, bringing the total available parking spaces to 97. Figure 2 shows a current site plan of the project location, and Figure 3 and Figure 4 shows the proposed changes to the athletic fields at Milwaukie Elementary School and along SE Lake Road.

**Figure 2 – Current Athletic Field Layout**





April 30, 2018  
Page 3 of 6

Figure 3 – Proposed Athletic Field Refinement Site Plan at Milwaukie Elementary School

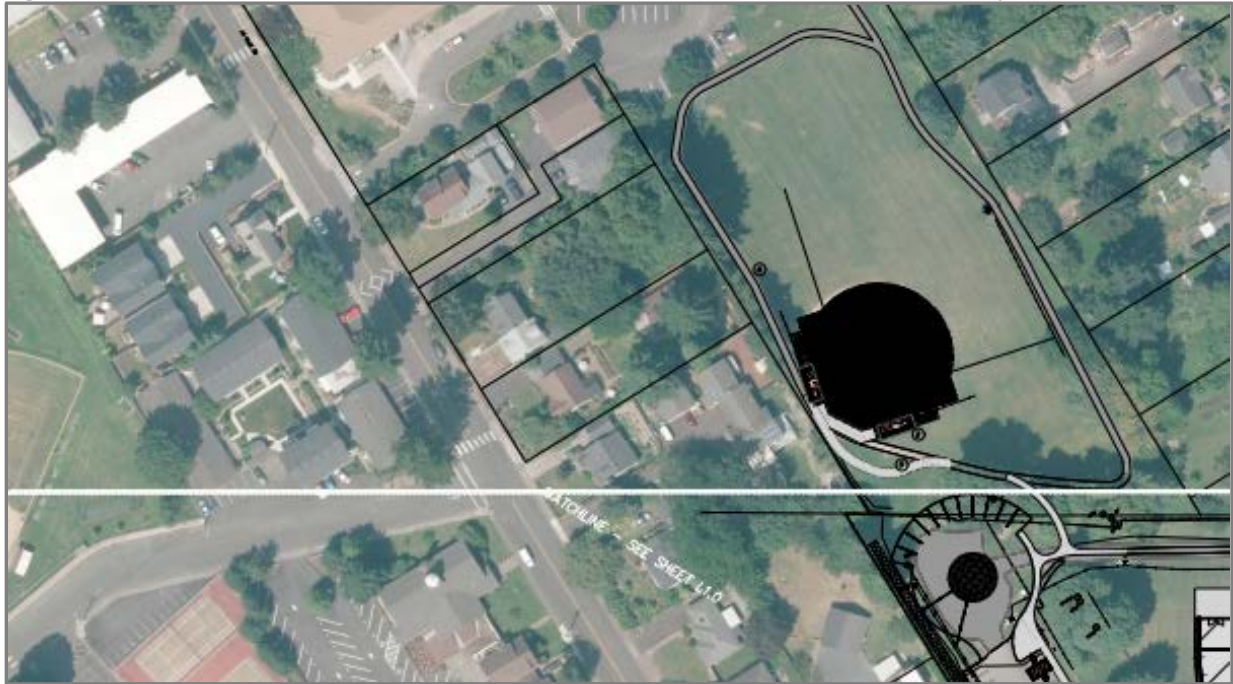
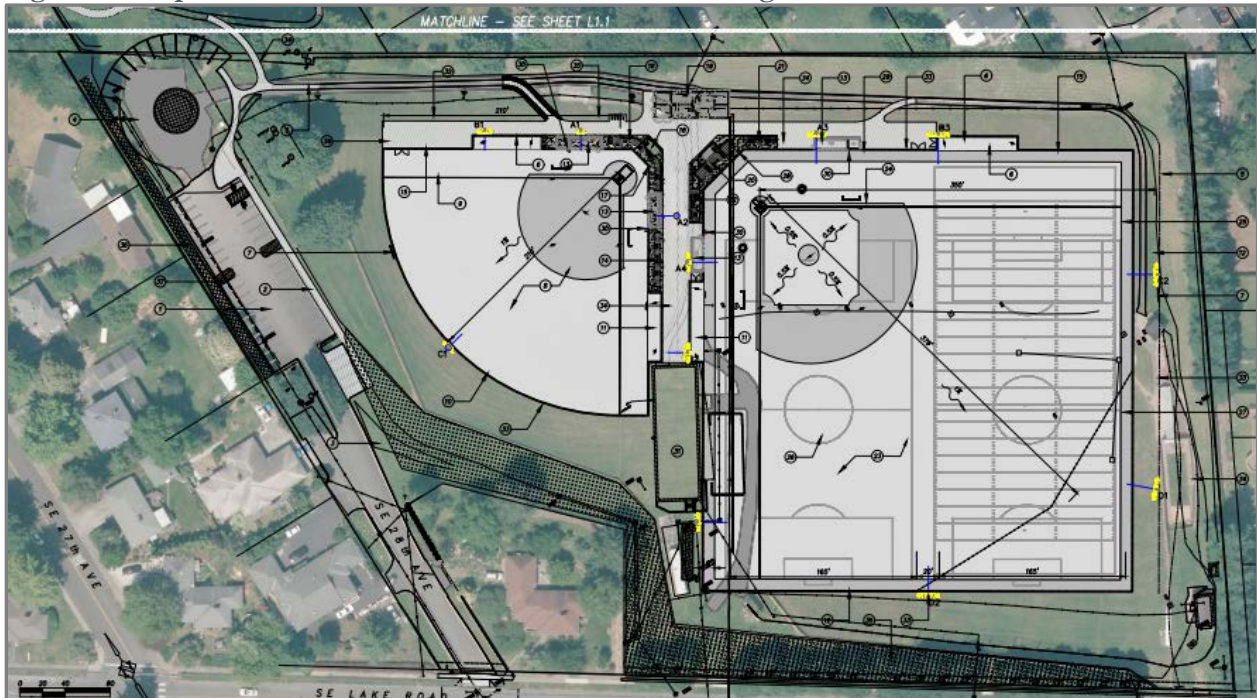

Figure 4 - Proposed Athletic Field Refinement Site Plan Along SE Lake Road





### ***Overflow Parking Observations***

If the athletic field parking lot is full during peak periods, visitors are encouraged to park at Milwaukie High School and Milwaukie Elementary School and walk to the field. Both parking lots are located less than half of a mile from the athletic fields.

Observations were made during the afternoon peak period on Wednesday, April 25<sup>th</sup>, 2018, when a several baseball games were in progress. The elementary school parking lot was observed to have two to three vehicles parked and it was assumed these were not associated with the baseball game. The northern half of the elementary school parking lot is shown in Figure 5. The high school parking lot was observed to have approximately ten vehicles parked. It is possible that some of these vehicles were baseball game visitors.

**Figure 5 - Northern half of Milwaukie Elementary School parking lot**



Nearby residents have expressed concern that neighborhood streets are full with overflow school-related parking during these periods. SE 30<sup>th</sup> Avenue and SE 31<sup>st</sup> Avenue are dead-end streets within the surrounding neighborhood that abut the athletic fields. These streets were observed to have extremely low volumes of parked vehicles during this period. SE 32<sup>nd</sup> Avenue is comprised of two dead-end streets, the southern segment accesses SE Lake Road and the northern segment accesses SE Wister Street. The segment of SE 32<sup>nd</sup> Avenue that accesses SE Lake Road had the most noticeable increased demand during this peak period.



However, all the vehicles parked on this street were parked legally (e.g. not blocking the end of the cul-de-sac or driveways). The dead-end of the street is shown in Figure 6.

**Figure 6 - SE 32nd Avenue Dead-End**



A couple of students were seen walking through the grass at the end of the cul-de-sac to access the other side of SE 32<sup>nd</sup> Avenue. The parking demand on the other side of SE 32<sup>nd</sup> Avenue was observed to be low, however, it is possible some students park on this northern segment of SE 32<sup>nd</sup> Avenue as well.

### ***Planned Parking Improvements***

To access the site from the parking lots available at both athletic fields, pedestrians can travel along a new pedestrian pathway network on both athletic fields from existing and new access points included as part of this plan.

Pedestrians who choose to park at the Milwaukie Elementary School can access the athletic fields by traveling along a new pedestrian pathway that will connect the parking lot at the elementary school to the athletic fields. In addition, pedestrians could also choose to exit the parking lot and walk south along SE 27<sup>th</sup> Avenue to SE Lake Road, turn east, and continue walking to the athletic fields. SE 27<sup>th</sup> Avenue features a low posted speed, as well as sidewalks on both sides of the street.



Figure 7 shows existing and proposed pedestrian circulation from parking lots to the athletic fields. Parking lots are shown in yellow, existing pedestrian circulation routes are shown in green, and proposed pedestrian connections are shown in orange.

**Figure 7 - Existing and Proposed Pedestrian Circulation (green and orange lines)**



*\*Note: South parking lot at Milwaukie High School (shaded yellow) has been removed from the most recent plans*

## **Conclusions**

While there is no additional area being added to the fields, the improvements may potentially see more usage from other youth organizations or community events. However, there should not be a large increase in attendance at one time. Additionally, there will be more parking spaces than existing and improved bicycle parking and connections to transit and the parking lots at the Elementary and High School.

The addition of 16 parking spaces to the athletic field parking lot will likely lessen the amount of overflow parking experienced by the surrounding neighborhood, which was observed to be minimal. However, it is recommended that the school district educate attendees of the parking available at the Elementary and High School parking lots to help minimize on-street parking on the neighborhood streets.

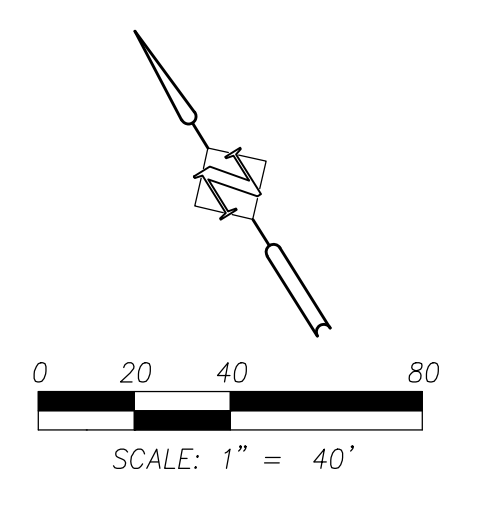
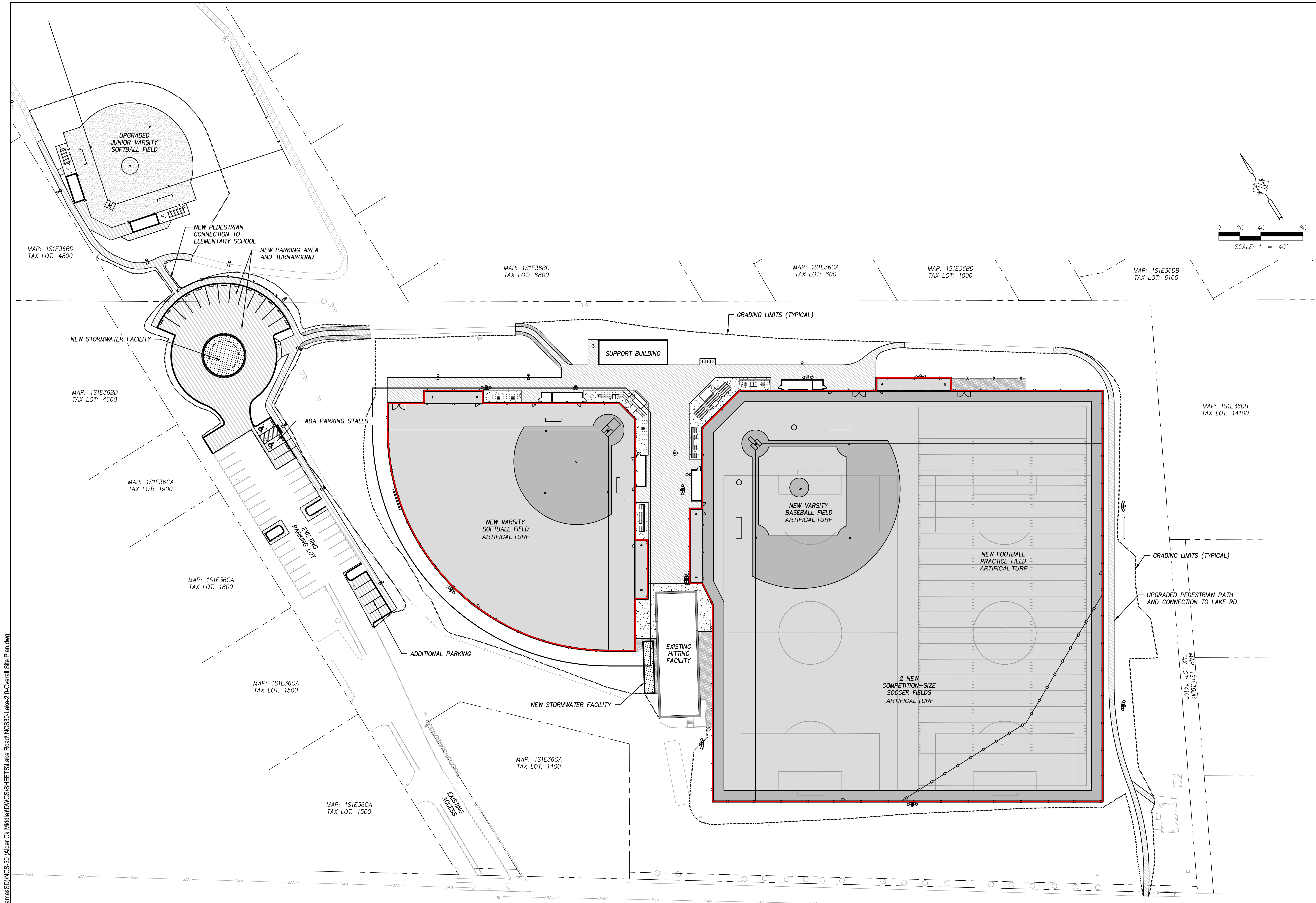

SE LAKE ROAD  
PLAN VIEW

P:\NCS (North Clackamas SD)\NCS-30 (Alder Ck. Middle)\DWG\SSHEETS\Lake Road\NCS30-Lake-2.D-Overall\_Site Plan.dwg

OVERALL SITE PLAN  
**MILWAUKIE HS LAKE RD FIELD IMPROVEMENTS**  
MILWAUKIE, OREGON

**Harper Houf Peterson**  
**Righellis Inc.**  
ENGINEERS & PLANNERS  
LANDSCAPE ARCHITECTS • SURVEYORS  
206 SE Spokane Street, Suite 200, Portland, OR 97202  
phone: 503.221.1131 www.hhpr.com fax: 503.221.1171

REGISTERED ARCHITECT  
Daniel K. Chin  
OREGON  
12/20/13

DESIGNED:	HHPR TEAM
DRAWN:	HHPR TEAM
CHECKED:	DSH
DATE:	3/2/2018

DATE	NO.	DESCRIPTION
		R E V I S I O N S

SHEET NO.  
**2.0**  
JOB NO.  
NCS-30

**MILWAUKIE HIGH SCHOOL  
LAKE ROAD FACILITIES  
ATHLETIC FIELD IMPROVEMENTS**

NORTH CLACKAMAS SCHOOL DISTRICT  
11678 SE 28TH AVE, MILWAUKIE, OR 97222

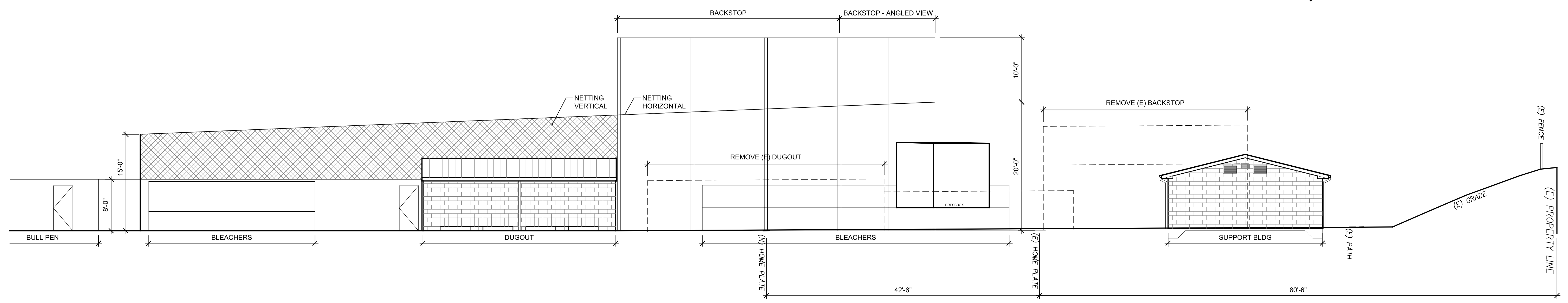
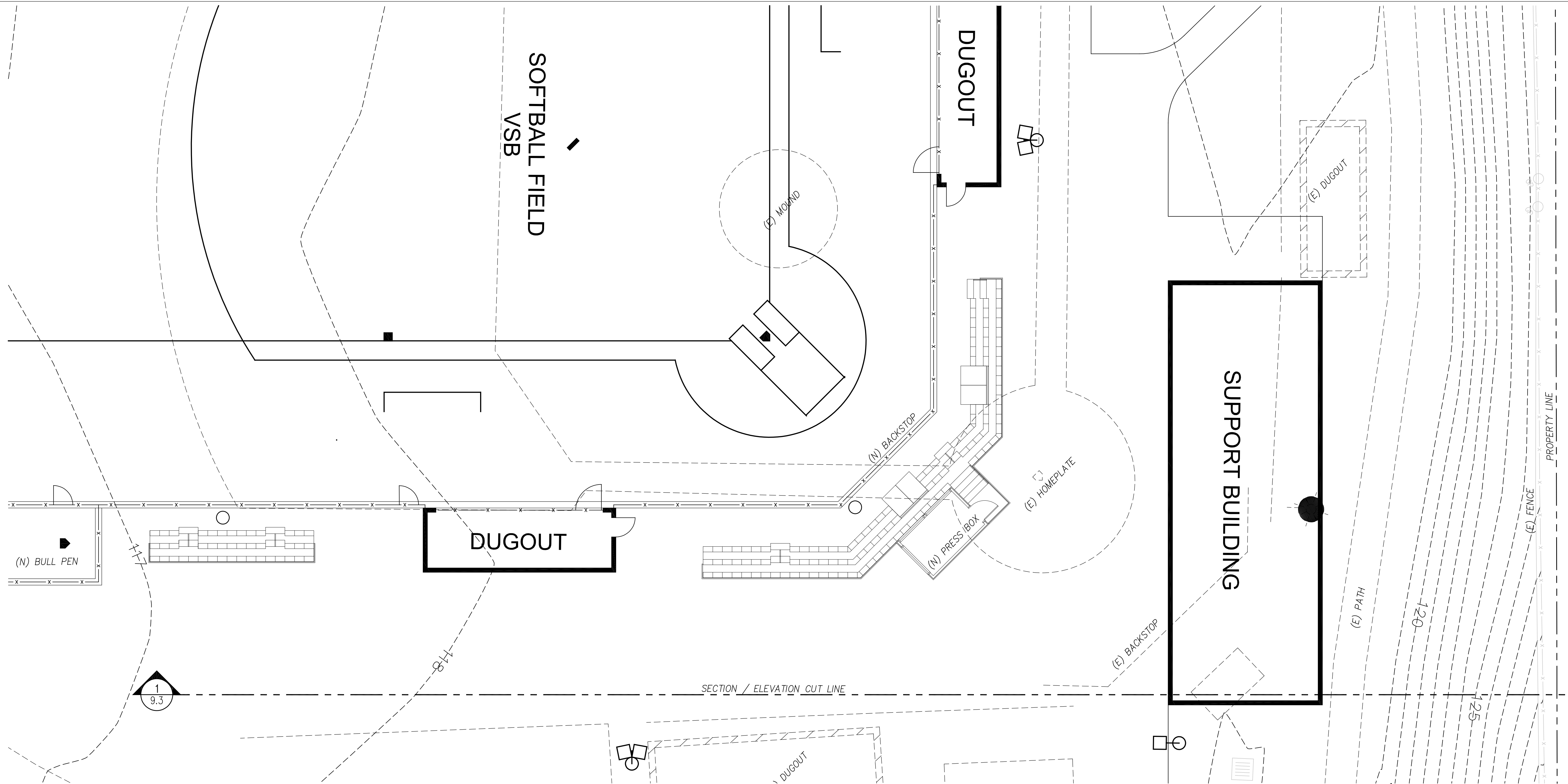

key plan

revisions	
phase	LAND USE
date	04.26.2018
project	17012

VSB SITE SECTION & PLAN

**9.3**



**MILWAUKIE HIGH SCHOOL  
LAKE ROAD FACILITIES  
ATHLETIC FIELD IMPROVEMENTS**

NORTH CLACKAMAS SCHOOL DISTRICT  
11678 SE 28TH AVE, MILWAUKIE, OR 97222

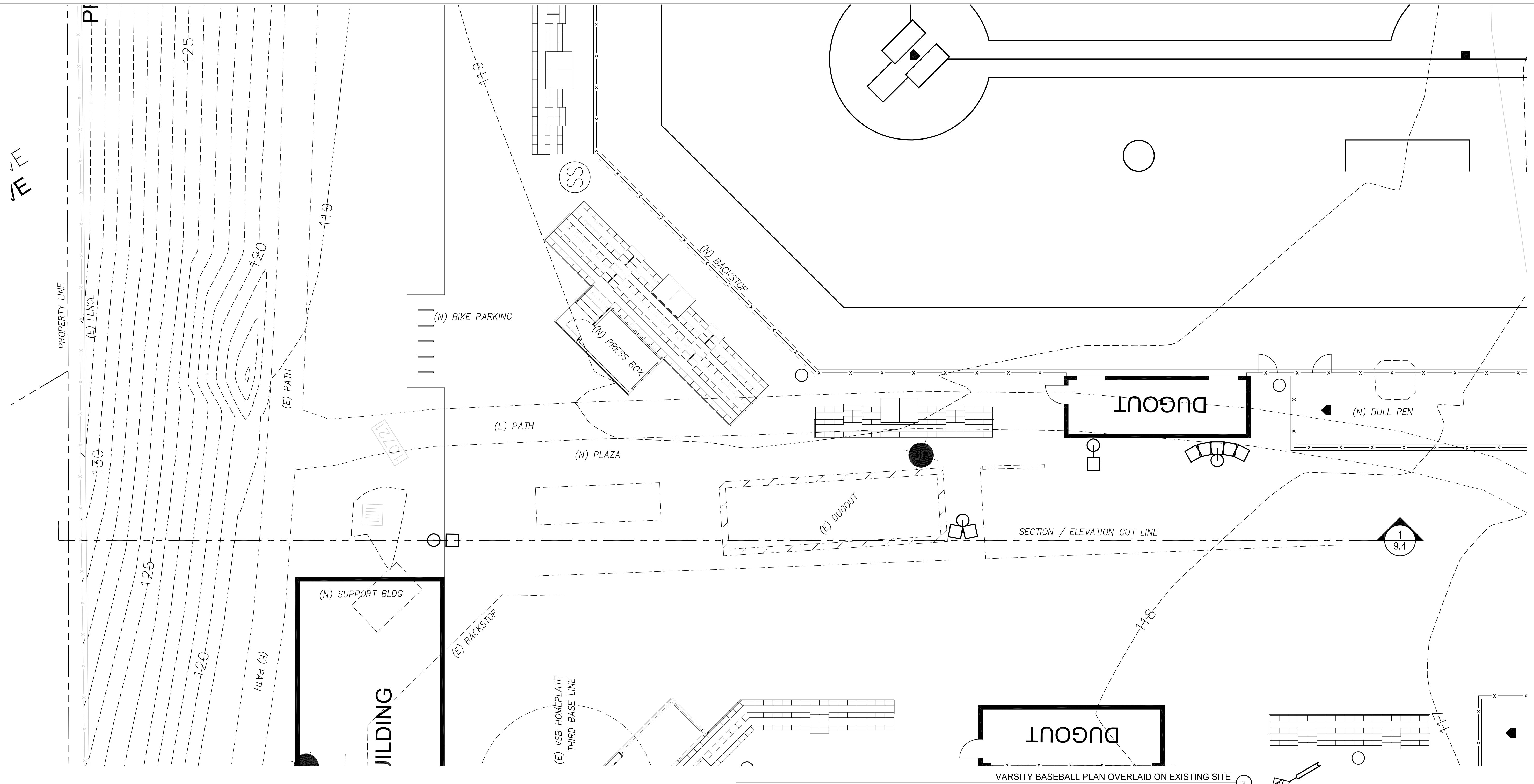

Varsity Baseball Plan Overlaid on Existing Site  
Scale: 1/8" = 1'-0"

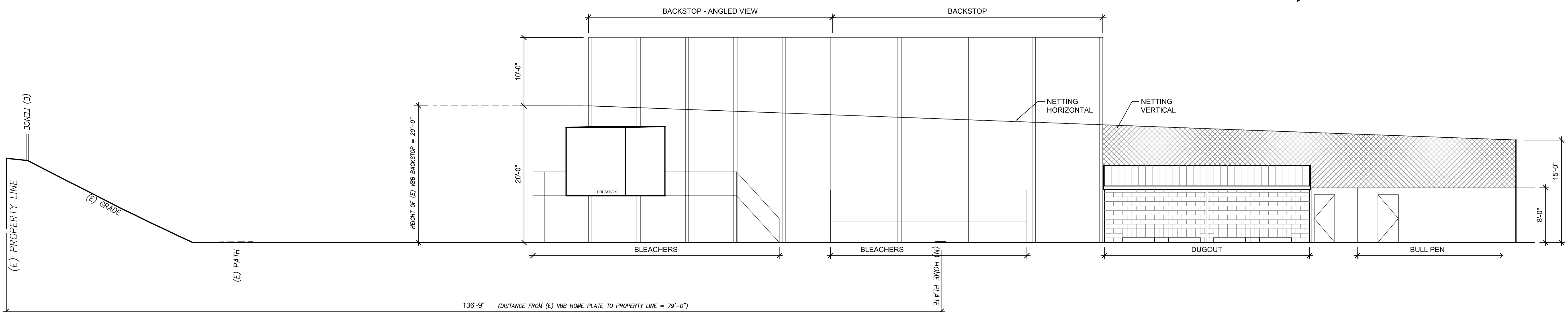

Varsity Baseball Backstop - East Elevation  
Scale: 1/8" = 1'-0"

**key plan**

revisions	

phase	BID SET
date	03.02.2018
project	17012

VBB SITE SECTION & PLAN

**9.4**

**MILWAUKIE HIGH SCHOOL  
LAKE ROAD FACILITIES  
ATHLETIC FIELD IMPROVEMENTS**

NORTH CLACKAMAS SCHOOL DISTRICT  
11678 SE 28TH AVE, MILWAUKIE, OR 97222

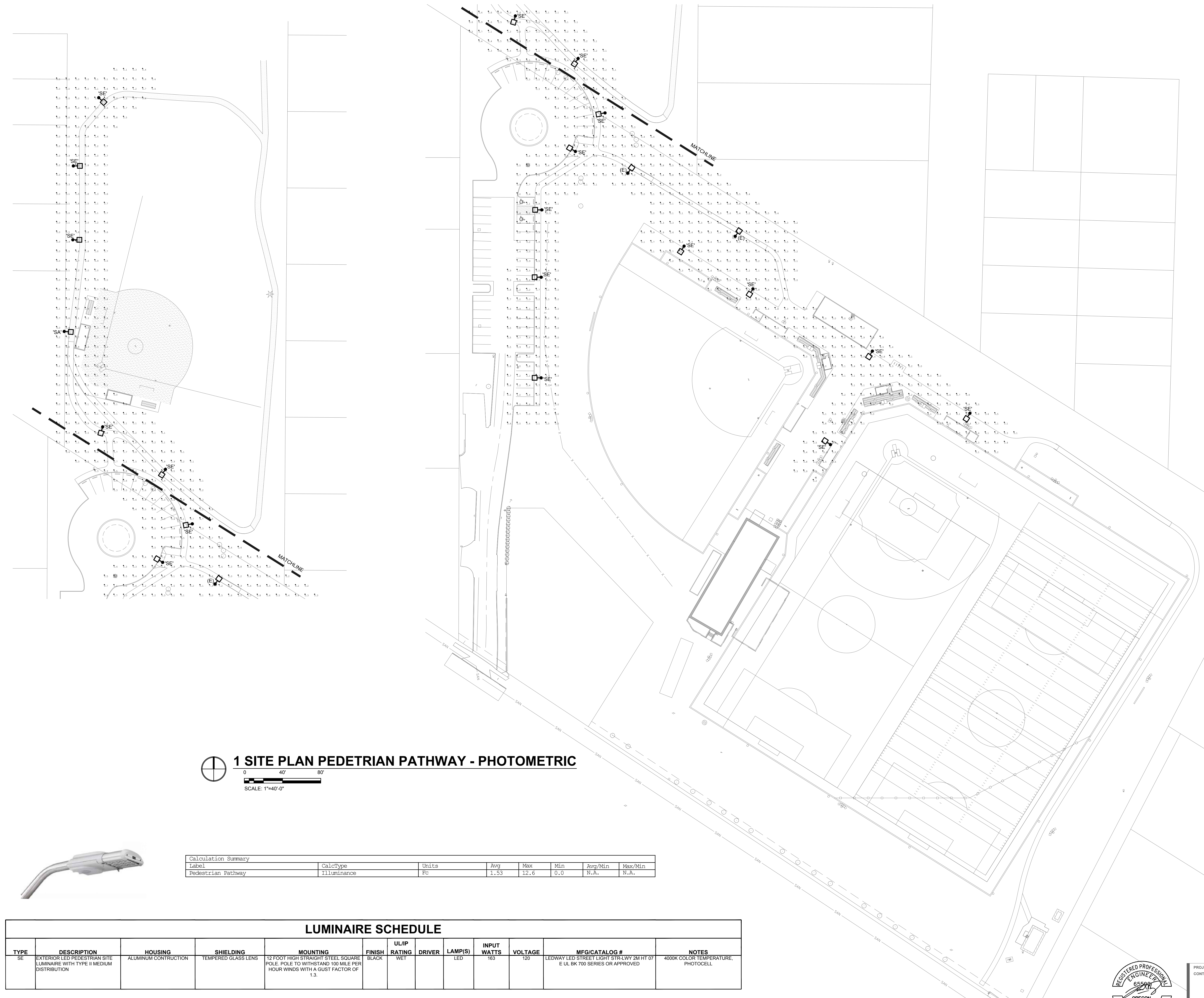

**1 SITE PLAN PEDETRIAN PATHWAY - PHOTOMETRIC**  
SCALE: 1"=40'-0"



Calculation Summary								
Label	CalcType	Units	Avg	Max	Min	Avg/Min	Max/Min	
Pedestrian Pathway	Illuminance	Fc	1.53	12.6	0.0	N.A.	N.A.	

LUMINAIRE SCHEDULE												
TYPE	DESCRIPTION	HOUSING	SHIELDING	MOUNTING	FINISH	UL/IP RATING	DRIVER	LAMP(S)	INPUT WATTS	VOLTAGE	MFG/CATALOG #	NOTES
SE	EXTERIOR LED PEDESTRIAN SITE LUMINAIRE WITH TYPE II MEDIUM DISTRIBUTION	ALUMINUM CONSTRUCTION	TEMPERED GLASS LENS	12 FOOT HIGH STRAIGHT STEEL SQUARE POLE. POLE TO WITHSTAND 100 MILE PER HOUR WINDS WITH A GUST FACTOR OF 1.5	BLACK	WET		LED	163	120	LEDWAY LED STREET LIGHT STR. LWY 2M HT 07 E UL BK 700 SERIES OR APPROVED	4000K COLOR TEMPERATURE. PHOTOCELL

key plan	
revisions	
phase date project	CD REVIEW SET 2.09.2018 17012

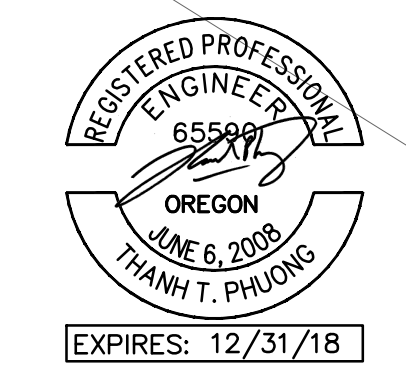

PROJECT 2017-0450  
CONTACT Thomas Phuong  
**INTERFACE ENGINEERING**  
100 SW Main Street  
Suite 1600  
Portland, OR 97204  
TEL 503.382.2266  
FAX 503.382.2262  
www.interfaceengineering.com

SITE PLAN  
PEDESTRIAN PATH  
PHOTOMETRICS  
**E1**

**MILWAUKIE HIGH SCHOOL  
LAKE ROAD FACILITIES  
ATHLETIC FIELD IMPROVEMENTS**

NORTH CLACKAMAS SCHOOL DISTRICT  
11678 SE 28TH AVE., MILWAUKIE, OR 97222

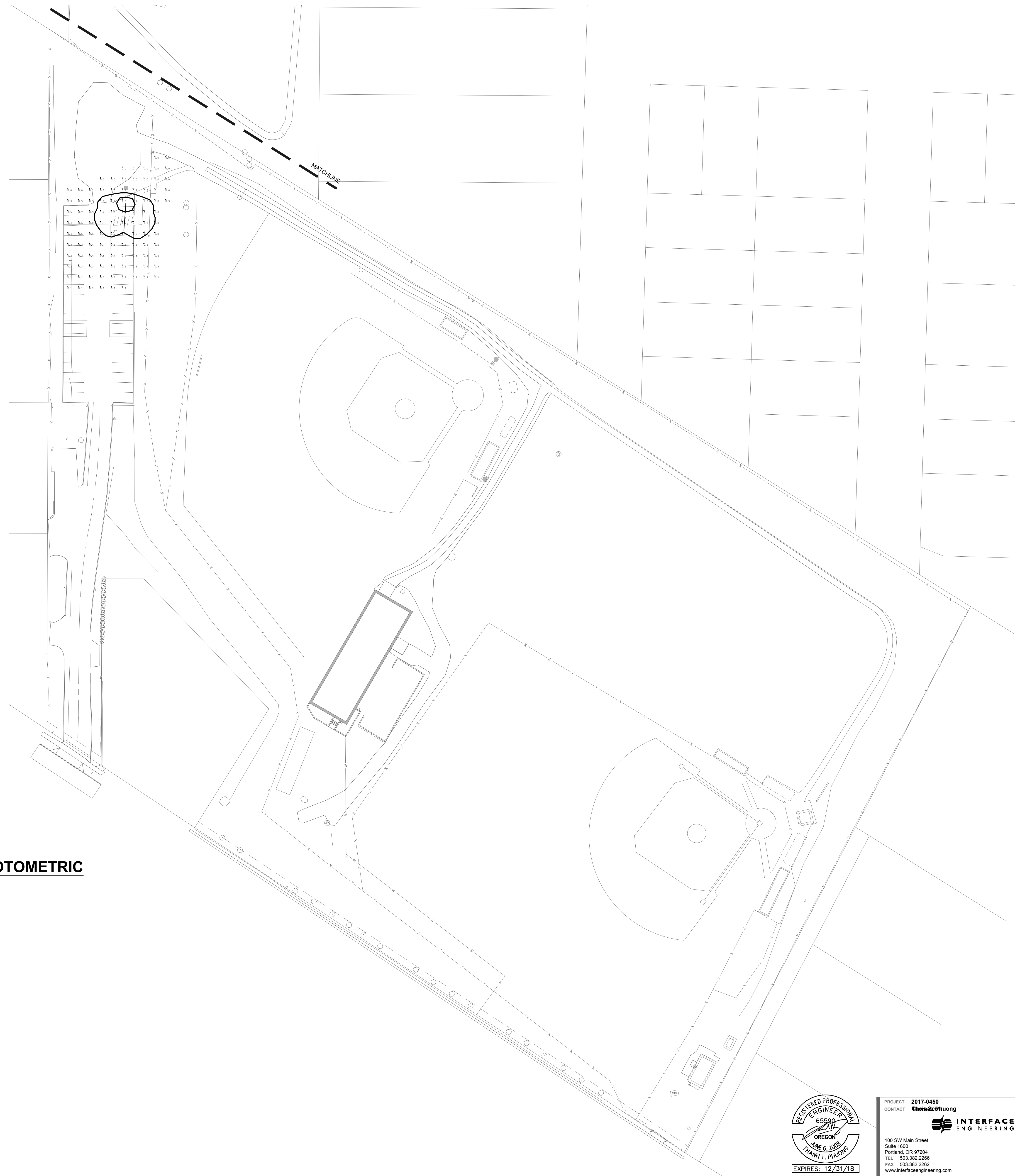

Calculation Pathway	Calc Type	Units	Area	Per	Vol	Per/Min	Spa/Min
Collection Pathway	1	1	1.37	2.3	1.3	11.2	11.2

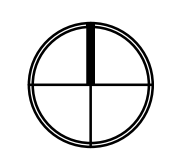

**1 EXISTING SITE PLAN - PHOTOMETRIC**

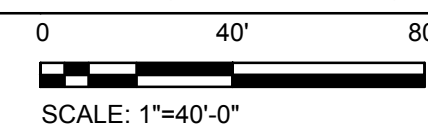

SCALE: 1"=40'-0"

key plan

revisions	phase date project
	CD REVIEW SET 2.09.2018 17012

EXISTING SITE PLAN  
PHOTOMETRICS

**E3**



PROJECT 2017-0450  
CONTACT **Chen & Luong**  
**INTERFACE ENGINEERING**  
100 SW Main Street  
Suite 1600  
Portland, OR 97204  
TEL 503.382.2266  
FAX 503.382.2262  
www.interfaceengineering.com

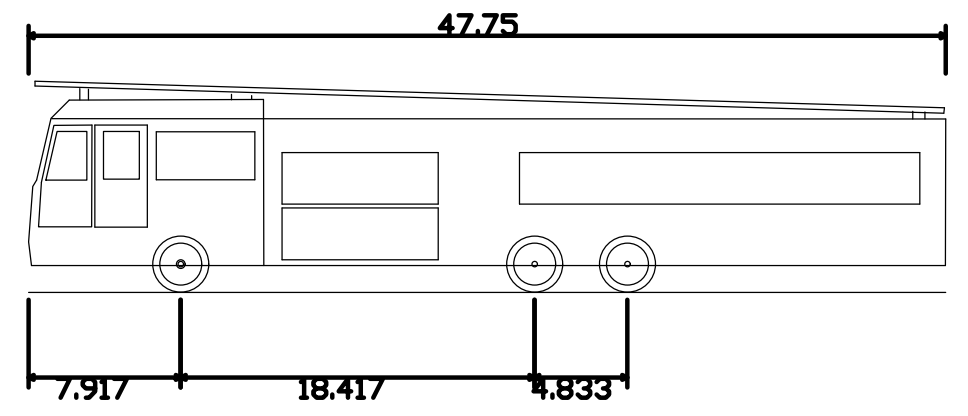

E-ONE HP95 Mid Mount  
 Overall Length 47.750ft  
 Overall Width 8.333ft  
 Overall Body Height 11.000ft  
 Min Body Ground Clearance 1.393ft  
 Track Width 8.333ft  
 Lock-to-lock time 6.00s  
 Max Wheel Angle 45.00°

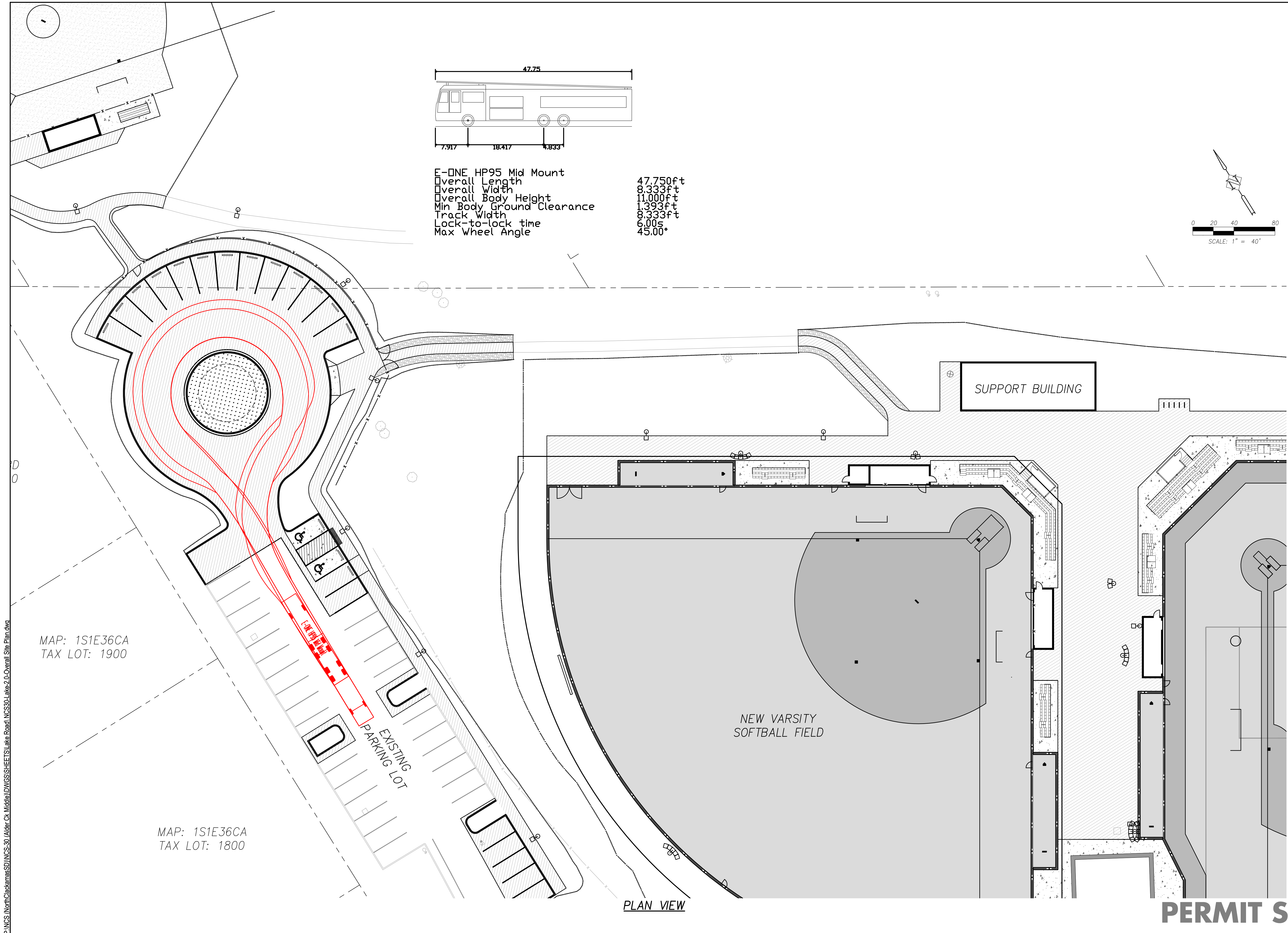
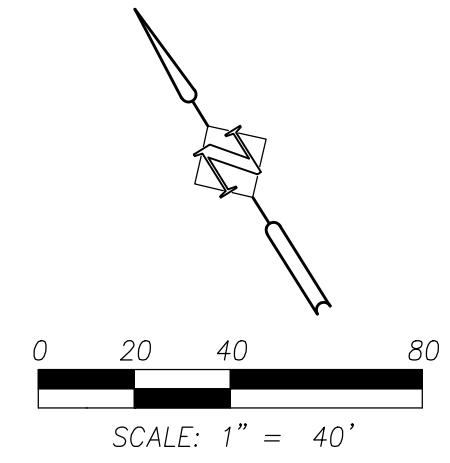

**OVERALL SITE PLAN**  
**MILWAUKIE HS LAKE RD FIELD IMPROVEMENTS**  
**MILWAUKIE, OREGON**

Harper Houf Peterson  
 Righellis Inc.  
 ENGINEERS + PLANNERS  
 LANDSCAPE ARCHITECTS + SURVEYORS  
 205 SE Spokane Street - Suite 200 - Portland, OR 97202  
 phone: 503.221.1131 www.hhp.com fax: 503.221.1171

DATE	NO.	DESCRIPTION	DATE
			3/2/2018

DESIGNED: HHPR TEAM  
 DRAWN: HHPR TEAM  
 CHECKED: DSH  
 DATE: 3/2/2018

**R E V I S I O N S**  
**2.0**

SHEET NO. 2.0  
 JOB NO. NCS-30

**PERMIT SET**

## **Community Use and Rental of District Facilities**

### 1. Objective

To provide a standard set of procedures for community use and rental of school facilities, grounds and equipment that is consistent with district policies.

### 2. Facilities Available

Designated classrooms, auditoriums, cafeterias, gymnasiums and fields may be available for use by the community. Facilities containing fragile or potentially hazardous equipment or confidential records may be made available at the principal's discretion.

District facilities may be available for community activities for a fee between 7:00 a.m. and 10:30 p.m. when not in use by the district. Current fee schedules are available through Community Services Department. Exceptions may be made with the approval of the Superintendent or designee.

### 3. Prohibited Activities

Any activities not appropriate for minor children are prohibited in district facilities. These activities include, but are not limited to: smoking; use of tobacco or marijuana; consumption of alcohol; use or possession of illegal or legal drugs; possession of weapons, firearms or explosives; gambling; and operation of potentially hazardous equipment. Activities deemed to be of a dangerous nature must have prior approval from the community services supervisor and the district's risk manager. Use of facilities are restricted to user. Subletting to other groups is prohibited.

### 4. Priorities for Use

The district is committed to youth and our local community groups. Youth groups are prioritized ahead of other groups. We prioritize use for organizations that serve primarily recreational youth teams to provide access for all students in alignment with the North Clackamas equity Board policy, GCCB/GDCB/IKAAA - District Equity Policy.

Within groups priority will be granted to organizations comprised of local members. Volunteer organizations will also receive preference over paid staff entities. The Board authorizes staff to use appropriate means to verify the local membership and volunteer organization status as necessary.

Groups and individuals using district facilities will be categorized as Class DPO (District Partnering Organization), A, B and C. Priority is given for use is in the order listed, with District Partnering Organization (DPO) having the highest priority. The categories are based on the nature of the organization, not the activity. Long term rentals are negotiated separately.

<b>Categories used by NCS D to determine priorities:</b>	
DPO	DPOs at their assigned fields/facilities, in-season (providing scholarships for NC students and full ongoing maintenance through the sports season of fields)
A	Partnering and local youth organizations or with over 90 percent North Clackamas youth; DPOs out-of-season or beyond assigned fields
B	Out-of-district youth organizations, adult leagues, civic/service groups, public agencies, colleges
C	Private interest or for-profit organizations

a. District Partner Organizations (DPO)

- (1) DPOs are youth organizations assigned to specific sites that are provided preferential scheduling and fee reduction in exchange for ongoing field maintenance and scholarships for North Clackamas families to increase access to sports for all students.
- (2) To retain DPO status, the organization needs to:
  - (a) Complete all of the required DPO application forms and process with community services schedulers.
  - (b) Serve primarily recreation teams in alignment with the North Clackamas equity policy.
  - (c) Serve district youth (90 percent of participants must attend or reside in the North Clackamas School District).
  - (d) Maintain and improve the fields assigned as planned in the application process.
  - (e) Offer and report scholarships (full and partial).
  - (f) Complete a biannual renewal process with the community services supervisor to review usage and adherence to the above commitments.

b. Class A - Local Youth Organizations and Local Youth Sports Leagues

Local nonprofit youth organizations, including DPOs, providing service to school-age children within district boundaries. Proof of nonprofit status (501(c)(3)) will be required. Each group must be comprised of at least 90 percent of district residents to qualify. The Oregon School Activities Association (OSAA) calendar will be used to determine sports seasons. Priority will be given to in-season recreation sports activities. This also includes DPOs out-of-season or using non-assigned sites.

c. Class B - Out-of-District Youth Organizations/Independent Youth Organizations, Civic and In-District Adult Leagues

- (1) Organizations/Private schools.
- (2) Youth organizations with less than 90 percent of district residents.
- (3) Adult recreation groups (including district staff).
- (4) Colleges and universities.
- (5) Community organizations of a civic or service nature, including those that provide services to youth but not solely that group.
- (6) Community groups sponsoring money-making activities where proceeds go to schools or charitable purposes.

The OSAA calendar will be used to determine sports seasons. Priority will be given to in-season recreation sports activities who provide scholarships for participants in need.

- d. Class C - Private Interest Groups and Profit-making Groups
  - (1) Private parties.
  - (2) Commercial activities.
  - (3) Political organizations and/or campaigns.

## 5. Application Process

Applicants must complete and submit an Application for Use of District Facilities form to the high school athletic director as scheduler for the use of high schools, or the community services scheduler for use of facilities for K-8 schools, including Alder Creek turf field and the Sabin-Schellenberg fields. Scanned, emailed or faxed applications are acceptable. Upon receipt of the completed application, the scheduler will:

- a. Determine the availability of the facilities within the district calendar for events including personnel and equipment if necessary.
- b. Determine the requester's classification/priority.
- c. Check form for accuracy and signature obtained.
- d. Route the application form (reservation) to the community services supervisor if the request is of a commercial or partisan political nature or is a long-term lease of facilities.
- e. Complete the facility rental reservation in computer system and execute contract.
- f. Collect payment, receive the insurance certificate and 501(c)(3) status, and give one copy to the user to keep as verification of approved use and retain a copy. Determine if use is a one-time use or reoccurring, and collect the fee as follows:
  - (1) One time use—collect anticipated fees to complete application process.
  - (2) Reoccurring use—collect first month's anticipated fees.
  - (3) Reoccurring seasonal use—collect fees for the duration of the season for entities such as youth sports that collect fees prior to league play.

In either case, actual charges will apply and supplemental billing will be done after the event if actual charges differ from collected fees or original billing. The reservation is not considered a confirmation until payment is made and the certificate of insurance is received.

The Board authorizes staff to develop additional department operational guidelines as appropriate.

- g. Staff will review fees annually. Fees are updated in July of each year and reflect actual increases by contract or billings. Fees are subject to an increase of up to five percent annually. Any increase exceeding five percent will require approval from the Board.
- h. Provide proof of insurance as required (See 7.B)

## 6. Appeals Process

Concerns regarding facility use can be addressed to the community services supervisor. If a concern cannot be resolved, it may be referred through the proper administrative channels for resolution.

7. Procedures Governing the Community Use of District Facilities

a. Supervision:

- (1) All groups using district facilities must provide a supervisor on site who shall be responsible for the group members and their actions during the time the facility is being used. The supervisor must be at least 21 years of age or a designated coach with an approved league. For children, the supervisor is responsible to stay until the last child has been picked up.
- (2) When use is granted during times that school or custodial staff is not available, a facility monitor will be responsible for locking and unlocking the facility and assisting the facility users as appropriate. Fees associated will be charged to all groups.
- (3) The district reserves the right to require police or other uniformed security personnel at any event where the community services supervisor feels it is necessary.
- (4) If the district determines additional security is needed for the use requested, the applicant must provide and pay for such security.

b. Liability insurance:

The applicant must provide an insurance certificate with the application. The insurance certificate shall provide evidence of general liability insurance with limits not less than \$1,000,000 per occurrence/\$2,000,000 annual aggregate, naming North Clackamas School District as additional insured.

Certificates of insurance will be required for:

- (1) Extended use (e.g. monthly meetings, etc.).
- (2) Physically active events (e.g., sport camps or fund-raising jogathons).
- (3) Formal organizations and nonprofits.
- (4) Public events (e.g. concerts).
- (5) Multiple site use.
- (6) Other activities as deemed necessary by the community services supervisor.

Users will be charged for damages or excessive wear on the use of facilities, sites or equipment.

c. Non-endorsement:

Granting use of district facilities does not imply district sponsorship or endorsement of the group or its activities.

d. Overnight stays:

Overnight stays are permitted by the district on a one-time-only basis. All such requests must be reviewed by the community services supervisor and the risk manager. Applicants must receive prior written approval from the appropriate fire marshal and reach agreement with the building principal (or community services supervisor during times when the principal is absent) regarding capable and responsible supervision. The district may require paid supervision.



- e. Key control: Refer to Board policy ECAA - Access to Buildings.

Keys or key cards will not be issued to nonstaff personnel. Any exceptions will be determined by the community services supervisor.

- f. Parking:

All facility users are to use the school parking lots and avoid parking on adjacent streets in order to allow for emergency vehicles and neighborhood traffic. Applicants may be required to provide written plans of how they intend to address potential parking problems. Failure to abide by the parking plan may result in termination of facility use. Applicants are responsible for removing trash accumulated during the event. Failure to remove trash will result in additional charges.

- g. Equipment and furniture:

Use of equipment, furniture and materials is subject to the provisions of Board policy KGF/EDC - Authorized Use of District Equipment and Materials.

If an organization would like to store equipment, install a structure or storage unit, the request must be included in the application process and approved by community services supervisor. The structure must be maintained by the organization, including keeping it free of graffiti or other visible physical damage. The structure is owned and insured by the DPO unless otherwise determined by the community services supervisor. The district will not be held responsible for any damage, theft or other destruction to property of the DPO. For any property, structure or storage unit on district property, the DPO shall provide the district with a certificate of insurance as evidence of property insurance coverage for the items stored on district property. Any such structure may be subject to space fee by the district. The District Capital Improvement form must be completed prior to building. Structure approval may be renewed during the application process and during the bi-annual renewal process, or it must be removed immediately upon request.

The North Clackamas School District retains the right to deny or limit access to persons or organizations who do not work in the spirit of collaboration, abuse the system, violate policy or fail to pay.

- h. Improvements or modifications to school buildings or grounds:

Grass removal, lining and chalking of fields, addition of top soil or removal of weeds, require written approval. Applicants must submit written plans to the community services supervisor who will review the plans in consultation with appropriate Facility Operations Department staff and the principal.

- i. Special facilities, areas and equipment:

- (1) Gymnasiums and multipurpose rooms: School gymnasiums and multipurpose rooms may be used for purposes appropriate to the facility. Appropriate footwear is required in all active sports and games. Any taping or attaching material to walls, floors or curtains must be approved by Facility Operations to ensure property is not damaged.

- (2) Cafeterias and kitchens: The use of kitchen facilities for food preparation requires the services of at least one district Nutrition Services employee. The Nutrition Services Department will be consulted for direction regarding requests for use of school kitchens. The user will be assessed the charge for food service support. School food, supplies and food storage areas are not available for community use.
- (3) Outside areas: The community services supervisor or the principal may require portable toilets to be provided at the applicant's expense. Placement will be determined by the district. Regular maintenance is the responsibility of the applicant.

j. Sports league scheduling:

- (1) Scheduling of district fields and gymnasiums for organized community sports leagues will be the responsibility of the Community Service Department. Principals shall refer all requests for use of gymnasiums and sports fields by leagues to the Community Service Department for K-8 sites.
- (2) League officials will complete the North Clackamas Facility or Field Use Application form.
- (3) League officials will present to the Community Service Department a schedule of games and practices. League officials will also provide current registration information for the league.
- (4) The Community Service Department will determine the facility needs of the organization and the availability of space and equipment.
- (5) Coaches requesting additional practice times or schedule changes should be referred to league officials who must request any schedule changes to the Community Service Department.
- (6) League officials will provide rosters including players' names and addresses and the school they attend.
- (7) League officials will provide scholarship information (see application).

k. Long-term use of district facilities (non-sport-related use):

- (1) Use of district facilities for activities may be granted initially for a term not to exceed 24 months, so long as such use does not infringe on or interfere with the operation of the regular school program. Use may be renewable for up to three years.
- (2) Requests must be made in writing to the community services supervisor.
- (3) The written request for use of a district facility must include the application forms with the following information:
  - (a) School for which use is being requested;
  - (b) Name of the organization;
  - (c) Mailing address;
  - (d) Names and addresses of its officers;
  - (e) Number of participants;
  - (f) Number of participants that are district residents; and
  - (g) Rooms and equipment that the entity intends to use.
- (4) The principal and the community services supervisor will determine the availability of facilities, supervisory staff and equipment. Upon approval of the request, the community services supervisor will determine the fee to be charged and meet with the principal and

the applicant to develop a plan for use. The community services supervisor will consult with the Facility Operations Department regarding custodial needs. The plan should address:

- (a) Areas of the building that will be used and conditions for use.
- (b) Areas of the building that are not to be used.
- (c) Duties of the paid supervisor.
- (d) Number of hours required for supervision and clean up.
- (e) Plan for alternate monitoring in case of illness or emergency.
- (f) Plan for emergency cancellation of activities.
- (g) Communication procedure for reporting problems and concerns.
- (h) Method for billing and collection of fees.

l. Intergovernmental agreements:

The district may enter into agreements with other governments or government agencies regarding the use of district facilities. In such cases, the terms of the agreement will take precedence over district administrative regulations for facility use.

m. Staff and applicant responsibilities:

(1) Principal

The principal is responsible for interpreting and administering district policies and regulations. The principal has overall responsibility for the operation of the district facilities, grounds, equipment and the scheduling for all district-related activities.

(2) Community Services Supervisor/Department

The community services supervisor is responsible for coordinating the scheduling of programs involving K–8 schools, such as youth sports leagues, other educational institutions, and agencies of government. The community services supervisor will coordinate and process all district-related requests (K-8) for use after school, weekends or vacations. The community services supervisor is responsible for facilitating site supervision on evenings (after 4 p.m.) and weekends when other district staff is not available and coordinate schedules with building staff. Scheduling of nonschool related activities after school or on nonschool days will be coordinated through the Community Service Department. All K-8 rental receipts go to Community Service Department. Community services will transfer revenue payments to the department that incurred the expense (e.g., facility for repairs, overtime to department charged, utilities costs to the energy unit, etc.).

(3) Facility Users

Facility users are responsible for completing the required district forms, providing responsible and capable program supervision, advance payment of fees, reporting all damages, providing proof of insurance when necessary, and compensating the district for any damages when required. Signer and supervision for facility use must be over 21

years of age. Facility users are responsible to comply with district administrative regulations and contractual agreements.

(4) Facility Operations Department

The Facility Operations Department is responsible for approving any improvements to school buildings or grounds.

(5) High School Athletic Director

Each high school athletic director is responsible to maintain the schedule and approve facility (buildings and fields) rental use at their high school in accordance with policy and this administrative regulation.



**FACILITY USE APPLICATION AND INVOICE**

**Fees are due in advance. Make checks payable to North Clackamas School District.**

**Mail to: Community Services, 6031 SE King Road, Milwaukie, OR 97222, Phone 503-353-6092 | Fax 503-353-6095**

**Email: [facilityuse@nclack.k12.or.us](mailto:facilityuse@nclack.k12.or.us)**

**APPLICANT INFORMATION**

Organization: \_\_\_\_\_ Contact/Signee: \_\_\_\_\_ Date: \_\_\_\_\_

Address: \_\_\_\_\_

City: \_\_\_\_\_ State: \_\_\_\_\_ Zip Code: \_\_\_\_\_

Email Address: \_\_\_\_\_ Day Phone: \_\_\_\_\_ Evening Phone: \_\_\_\_\_

Purpose: \_\_\_\_\_

Estimated youth attending: \_\_\_\_\_ Estimated adults attending: \_\_\_\_\_ Participants: Indistrict \_\_\_\_ Out-of-district \_\_\_\_

Scholarship: # \_\_\_\_\_ for full scholarship at \$ \_\_\_\_\_; # \_\_\_\_\_ for partial scholarship at \$ \_\_\_\_\_

Sports Organizations: What percent of the teams are considered a "recreation" team? \_\_\_\_\_

Equipment and services requested: \_\_\_\_\_

Dates requested	Time requested (start and end)	School/Building	Room/Area	Confirmed by District

*The undersigned hereby agrees to comply with all regulations governing the use of the facility as established by the Board of Education of North Clackamas School District. The undersigned will exercise due care in the use of the facilities and pay for such damages as may arise from such use. The undersigned is solely responsible for loss, damages, accidents and personal injury arising out of the use of the facility and agrees to indemnify and hold harmless the school district, its Board of Directors and staff from and against all claims. Applicants may be required to provide proof of insurance.*

\_\_\_\_\_  
Print Name

\_\_\_\_\_  
Signature

\_\_\_\_\_  
Date

**Office Use:**

Tier: Rate/hour: \$ \_\_\_\_\_ X # hours \_\_\_\_\_ = Invoice Due \_\_\_\_\_ Paid \_\_\_\_\_

- Scheduled in booking
- Confirmation sent

- Special custodial arrangements complete
- Food services arrangements complete

Comments: \_\_\_\_\_