



NAPOLEON JUNIOR/SENIOR HIGH SCHOOL 2022-2023

Revised (May 2022)

701 Briarheath Ave.

Napoleon, OH 43545

Telephone: 419-599-1050

FAX: 419-599-8537

ADMINISTRATION

PRINCIPAL: Mr. Ryan Wilde

ASSISTANT PRINCIPAL: Mr. Brian Burden

ASSISTANT PRINCIPAL: Mrs. Michele Roberts

ATHLETIC DIRECTOR: Mr. Andrew Ham

GUIDANCE COUNSELORS

Mrs. Megan Frankart

Mrs. Megan Gerken

Mrs. Heidi Mekus

COVER & INSIDE PHOTOS COMPLIMENTS OF THE NHS ANNUAL

This agenda belongs to:

Name: _____

Address: _____

City/Town: _____

Zip Code: _____ Phone #: _____

The information in this book was the best available at press time. Watch for additional information and changes.



powered by sdi innovations

No part of this publication may be reproduced, stored in a retrieval system, or transmitted in any form without getting prior written permission of the publisher.

© 2022. SDI Innovations. All Rights Reserved.

2880 U.S. Hwy. 231 S. • Lafayette, IN 47909 • 765.471.8883
www.schooldatebooks.com • sdi@schooldatebooks.com

INDEX

2022-2023 - Bell Schedules	18	Grade Point Average and Class Rank	21
2022-2023 - District Calendar	17	Grading System	21
A Message From the Administration	3	Intramural Sports	24
Academic Information	20	Library Media Center (LMC)	22
Alma Mater	4	Locks and Lockers	19
Assemblies and Programs	16	Lunch	20
Athletic Code of Conduct	23	Medication Guidelines	22
Athletic/Activity Requirements	23	Mission Statement and Goals	3
Athletics/Activities	23	NCAA	24
Attendance Policies and Procedures	13	Notice of Nondiscrimination & Internal Complaint Procedures	13
Automobiles and Student Parking	20	Participation in School-Related Functions	22
Behavior Code and Discipline	6	PBIS at Napoleon Junior/Senior High	5
Book Bags and Purses	20	Restrooms	19
Cell Phone/Electronic Communication Devices (ECD)	9	School Attendance in Summary	16
Co-Curriculars Clubs/Activities	24	School Colors	4
College Credit Plus Program (CCP)	21	School Motto	4
Computer Use	22	School Procedures	16
Concealed Carry Law	19	Search and Seizure	19
Disciplinary Actions	11	Student Dress Code	12
District Motto	4	Student Drug/Alcohol Testing Policy	23
Eighteen Year Old Students	20	Student One -To-One Computer Agreement	8
Eligibility	23	Student Schedules	20
Emergency Medical Forms	22	Study Halls	16
Extra-Curricular Activities	23	Telephone Use by Students	22
Fees	21	Transportation	12
Fight Song	4	Varsity & Club Sports	24
Fire, Tornado, and Safety Drills	22	Visitors	20
General Information Approval of Events	22	Weather Related Announcements	22



MISSION STATEMENT AND GOALS

The Napoleon Area School District has developed a Continuous Improvement Plan based on the evaluation of the district's strengths and weaknesses by committees that included students, staff, parents, and community members.

It is the mission of the Napoleon Area School District is to LEAD, LEARN, & LIVE in pursuit of excellence.

District Goals

The Napoleon Area Schools will:

1. Improve all learner outcomes and exceed state minimum requirements.
2. Improve parental and community involvement in the educational process.
3. Improve the learning environment

A MESSAGE FROM THE ADMINISTRATION

Welcome to a new school year at Napoleon Junior/Senior High School. This student handbook has been prepared just for you — to help you understand the rules and procedures of your school. The entire Napoleon Junior/Senior High School staff wants to make sure that you have a great year as well as an understanding of the school's expectations. A successful school year begins with a positive learning environment in a building that is clean and well maintained where:

- Students feel secure and safe.
- Teachers spend their time teaching and helping students.
- Parental involvement is expected and appreciated.

The policies described in this handbook are based on respect for individuals, respect for the rights of others, and respect for your school. Please contact any teacher or counselor for academic help or advice whenever you need it. Also, the administration and staff are always available to assist you. We truly want to make this your best school year ever.



ALMA MATER

On the banks of Maumee Waters,
Fair and Staunch and Bold
Stands our Noble Alma Mater,
Glorious to behold.
Lift the chorus,
Speed it onward,
Let us ere be true.
Hail to the Napoleon High School,
Hail the white and blue.

SCHOOL COLORS

Navy Blue and White

DISTRICT MOTTO

“Our Future Starts Now”

FIGHT SONG

Fight the team across the field,
Show them Napoleon’s here.
We’re going to set the earth reverberating with a mighty cheer,
Rah, Rah, Rah.
Hit them hard and see how they fall,
Never let them- team get the ball.
Hail, hail the gang’s all here
as we march on to victory.

SCHOOL MOTTO

“We Believe That We Will Win”



PBIS AT NAPOLEON JUNIOR/SENIOR HIGH

A General Overview

At Napoleon Junior/Senior High, the main focus of Positive Behavioral Interventions and Supports (PBIS) is to provide a clear system for all expected behaviors. Through PBIS we will work to create and maintain a positive, productive, and safe environment in which ALL school community members (administration, faculty/staff, parents and students) have clear expectations and understandings of their role in the educational process.

Proactive Approach to School-Wide Discipline

This school-wide system of supporting positive behavior focuses on a team-based system approach and teaching appropriate behavior to all students in the school. The goal of PBIS at Napoleon Junior/Senior High is to accomplish the following:

1. **Behavioral Expectations are Defined.** Behavioral expectations are clearly defined in positive, simple rules in the Code of Conduct:
 - Be Respectful—Be mindful of the people, places, and things around me.
 - Be Responsible— Follow through and take control of your success.
 - Be Safe—Keep yourself and others out of harm's way.
2. **Behavior Expectations are Taught.** The behavioral expectations are taught to all students at the beginning of the school year and throughout the year as needed. Teaching staff is provided with behavioral lesson plans designed to help "teach" students the expected behaviors. The general rule is presented, the rationale for the rule is discussed, positive examples ("right way") are described and rehearsed, and negative examples ("wrong way") are described and modeled. Students are given the opportunity to practice the "right way" until they demonstrate fluent performance.
3. **Appropriate Behaviors are Acknowledged.** Once appropriate behaviors have been taught, they need to be acknowledged on a regular basis. Through PBIS we have designed a formal system for faculty/staff to consistently recognize and reward students who demonstrate expected behaviors.
4. **Behavioral Errors are Corrected Proactively and are recorded.** Students, faculty/staff, and administrators will be able to predict what will occur when behavioral errors are identified. A School-Wide Information System (SWIS) has been put into place for staff to document incidents managed by staff and office. The Student Behavior Management Flowchart is used to help faculty/staff distinguish major from minor behavioral incidents and when to document these behaviors.
5. **Decisions About Behavior Management is Data Based.** One of the most important features of PBIS is the use of a data management system to track discipline incidents. The data will be used by the PBIS Team to help determine the type of incidents that are occurring, where, when, and who is involved. The data will eliminate the guesswork from the decision making process about what is and what is not working in the school's behavior management system. Data reports can enable administration to devote resources and time to the precise people, place, and school day period that need them.

Behavior Expectations

At Napoleon Junior/Senior High School, we believe that each student, staff, and visitor should be treated with courtesy and respect. This will promote and maintain a safe, positive, and appropriate educational climate. The following guidelines will assist each student to develop self-discipline and meet our school's behavior expectations:

1. Follow the teacher's directions the first time that they are given.
2. Be in your assigned seat, prepared for class, when the bell rings.
3. Show respect for staff and fellow students by speaking courteously and keeping your hands, feet, and personal things to yourself.
4. Only use language that is appropriate for this setting.
5. Represent yourself, a Napoleon Senior High School student, in a creditable, honorable, respectful, and responsible manner at school and school-related events, at home or away.

BEHAVIOR CODE AND DISCIPLINE

Napoleon Junior/Senior High School students, including those attending Four County Career Center, IEC, off-campus CBI, or any other facility while a student of Napoleon Junior/Senior High School are required to behave in a socially and legally acceptable manner at all times including both on and off the school property including in sight of or in view of school property and/or school personnel/representatives. This policy applies to all misconduct by a pupil that occurs off of property owned or controlled by the district but that is connected to activities or incidents that have occurred on property owned or controlled by that district and misconduct by a pupil that, regardless of where it occurs, is directed at a district official or employee, or the property of such official or employee. activities in the District, including activities on school property, on a school bus, or while enroute to or from school, and those occurring off school property if the student is at any school-sponsored, school-approved or school-related activity or function, such as field trips or athletic events where students are under the school's control, in a school vehicle, or where an employee is engaged in school business. Violations of school rules will result in disciplinary actions. The Napoleon Police Department may be called when a student violates a law, which governs the citizens of the Napoleon Area School District.

Definitions of major offenses are as follows:

1. **Dangerous Weapons/Instruments-** Student shall not bring, possess, transmit, conceal, or store any weapon or instrument capable of harming another person such. This includes any explosive, incendiary or poisonous gas (mace), bomb, grenade, rocket, missile, mine or other device similar to any to the devices listed above. Students are prohibited from bringing or possessing a firearm or concealed weapon on school property, in a school vehicle, or to any school-sponsored activity.
2. **Use/Possession of Tobacco or Tobacco Related Products** - No student shall use or possess tobacco in any form, including but not limited to: cigarettes, cigars, chewing tobacco, snuff and any other tobacco related products including e-cigarettes, vapor pens/devices, vapor liquid, or vapor accessories. Use/possession in or about a school building, on school grounds, or school busses, or at any activity supervised by the school district is prohibited.
3. **Use/Possession of Alcohol** - No student shall possess, use, transmit, sell or attempt to sell, or be under the influence of alcohol. No student shall come to school, remain at school, or attend any school sponsored activity with the smell of alcohol on his/her breath/clothing or showing signs of consumption, regardless of when or where the alcohol was consumed.
4. **Use/Possession of other Drugs** - No student shall possess, (including, but not limited to possession in purse, wallet, locker, ask, automobile on school property, etc.) use, transmit, sell or attempt to sell, have the distinct odor of, or be under the influence of any narcotic drug, controlled substance, hallucinogenic drug, amphetamine, barbiturate, marijuana, anabolic steroid, mind altering substance of any kind or intoxicant of any kind. No student shall come to school, remain in school, or attend any school sponsored activity with the smell of such chemicals or substances on his/her breath/clothing or showing signs of consumption regardless of when or where the chemical or substance was consumed/used. Use of a drug authorized by a medical prescription from a registered physician shall not be considered a violation of this rule if a written statement from a licensed health professional authorized to prescribe drugs is accompanied by the written authorization of the parent (Board Policy 5330). No student shall use, possess, or transport paraphernalia that is commonly associated with or construed to be used for any of the above mentioned chemicals or substances.
5. **Harassment, Intimidation, or Bullying-** Harassment, intimidation, or bullying toward a student, whether by other students, staff, or third parties is strictly prohibited and will not be tolerated. This prohibition includes aggressive behavior, physical, verbal, and psychological abuse, and violence within a dating relationship. Napoleon Area Schools will not tolerate any gestures, comments, threats, or actions which cause or threaten to cause bodily harm or personal degradation. Harassment, intimidation, or bullying means: Any intentional written, verbal, electronic, or physical act that a student or group of students exhibits toward another particular student(s) more than once and the behavior both causes mental or physical harm to the other student(s) and is sufficiently severe, persistent, or pervasive that it creates an intimidating, threatening, or abusive educational environment for the other student(s); or violence within a dating relationship.
6. **Vandalism-** A student shall not cause or attempt to cause damage or vandalize the property of another, public or private on school premises, or at any school activity on or off school grounds. Marking, defacing, or damaging school property or grounds will not be tolerated, including but not limited to, damage and/or destruction of information, electronic or other. This includes vandalism to the property of school employees both on and off school property.

7. **Disruption of the Educational Process-** Student shall not participate in the disruption of school by the use of violence, force, coercion nor any other disruptive activity. Students will not cause material disruption or obstruction to the normal school day or any school-related function. Disruption of class, lunch time, or school activities through either verbal or physical actions. Any act that regardless of intent suggests harm, inconvenience, or creates unrest (this includes threats & hoaxes) is strictly prohibited. This includes, but is not limited to false alarms, false claims, dishonesty, forgery, and the unauthorized use of fire or incendiary devices, gambling, joking violence, and/or any other activity that the administration deems disruptive. Students will obey the instructions of any staff member at all times.
8. **Threats, Obscenity, & Profanity-** Students shall not use profanity, obscene gestures, nor possess obscene materials. Students will not show any sign of disrespect towards any school employee, student, or visitor. Students shall not act, behave, or talk in any way that may be construed as a threat upon the mental or physical well-being of any student, school employee, or visitor. The unauthorized touching of any staff member, will not be tolerated.
9. **Aggressive Behavior, Physical Harm, & Disrespect-** Students shall not cause physical harm to another student, staff member, or visitor. Students will not threaten, harass, haze, fight, or show disrespect to fellow students and/or any other individuals at school. Fighting, unauthorized touching, or disruptive and/or inflammatory language that provides the potential to result in a fight or conflict of any kind is strictly prohibited. This includes pushing, shoving, hitting, kicking, throwing objects, name calling, and threats of a verbal or written nature.
10. **Theft/Stealing-** Students shall not steal, attempt to steal, or cause to steal any private or school property. Unauthorized use, possession, or damage to the property of another is strictly prohibited including, but not limited to, unauthorized duplication, copyright infringement, and/or theft of information, electronic or other.
11. **Cheating/Dishonesty-** Students shall not commit academic dishonesty. Students will not cheat, attempt to cheat, assist, or encourage another student to cheat on any assigned class work, quizzes, or tests. This includes the transmission, use, sale, or obtaining of any unauthorized academic information, electronic or otherwise.
12. **Unauthorized Location-** Students shall not use or leave the building or property without proper authorization. This includes being in an unauthorized area during the school day and trespassing.
13. **Good Neighbor Policy-** The Napoleon Area City School District strongly believes all students should respect the property and rights of community members who live directly adjacent or near district owned facilities/property. In an attempt to maintain positive community relations, school officials will enforce board approved policy regarding the code of conduct in near proximity to district owned facilities/property or within a reasonable distance to district owned property.
14. **Discriminatory Harassment -** Discriminatory practices will not be tolerated (Board Policy 5517). The Board of Education will vigorously enforce its prohibition against discriminatory harassment based on race, color, national origin, sex (including sexual orientation and gender identity), disability, age (except as authorize by law), religion, ancestry, or genetic information (collectively, "Protected Classes") that are protected by Federal civil rights laws (hereinafter referred to as unlawful harassment). Conduct constituting discrimination based on Protected Class may include, but is not limited to, the following:
 - Verbal - The making of offensive written or oral innuendoes, comments, jokes, insults, threats, or disparaging remarks based on Protected Class
 - Nonverbal - Placing offensive objects, pictures, or graphic commentaries in the school environment or making insulting or threatening gestures based on Protected Class.
 - Physical - Any intimidating or disparaging actions such as hitting, pushing, shoving, or spitting based on Protected Class.
15. **Inappropriate Acts or Excessive Horseplay -** Any inappropriate behaviors which are deemed serious by an administrator due to the nature or repetition of the act or excessive horseplay
16. **Insubordination -** A student shall not disregard or refuse to follow school rules, regulations, assigned disciplinary consequences, or reasonable directives by school personnel.
17. **Unwelcome Sexual Conduct -** Students shall not engage in unwelcome sexual advances, requests for sexual favors, or other physical or verbal conduct or communication of a sexual nature, including gender-based harassment that creates an intimidating, hostile, or offensive education environment such as pinching, grabbing, suggestive comments, gesture, or jokes or pressure to engage in sexual activity.

18. **Student Hazing** - Hazing activities of any type are inconsistent with and disruptive to the educational process, and prohibited at any time in school facilities, on school property, and/or off school property if the misconduct is connected to or associated with Board-sponsored activities (e.g., extracurricular teams, clubs, or groups) or incidents that have occurred on school property. Additionally, no student shall plan, encourage, or engage in any hazing.

Hazing is defined as doing any act or coercing another, including the victim, to do any act of initiation into any class, team, or organization or any act to continue or reinstate membership in or affiliation with any class, team, or organization that causes or creates a substantial risk of causing mental or physical harm to any person, including coercing another to consume alcohol or a drug of abuse. No person shall recklessly participate in the hazing of another. Permission, consent, or assumption of risk by an individual subjected to hazing shall not lessen the prohibitions contained in this policy.

19. **Obstruction** - No student, with purpose to hinder the investigation, discovery, or punishment for a violation of the student code of conduct or law by him or herself, or another student, or to conceal from discovery or seizure, contraband or evidence of a violation of the student code of conduct or law by him or herself or another student, shall do any of the following:

- (1) Destroy or conceal the existence of any contraband or evidence of a violation of the student code of conduct or law, or to induce or coerce any other person from withholding information that would lead to the discovery of the same;
- (2) Refuse to consent to a search by school officials for contraband or evidence of a violation of the student code of conduct or law where the school has individualize reasonable suspicion to support conducting the search;
- (3) Warn another student of the impending discovery of contraband or the evidence of a violation of the student code of conduct or law;
- (4) Communicate false information to any school official conducting an investigation of a violation of the student code of conduct or law;
- (5) Prevent or obstruct any school official, by means of force, intimidation, or deception, from performing any act to aid in the investigation, discovery, or punishment for a violation of the student code of conduct or law, or from the discovery or seizure of contraband or evidence of a violation of the student code of conduct or law.

20. **Misuse of District/Electronic Communication Devices (ECDs)** - Students are expected to follow the guidelines outlined in the Student Technology Acceptable Use and Safety Policy (BOE 7440.03). Additionally, no student shall use a cell phone or other ECD device in violation of any student code of conduct, computer usage agreement, and/or bullying policy.

21. **Public Display of Affection (PDA)** - PDAs are not considered in good taste or an acceptable behavior. This may include hugging, kissing, holding hands, or other sexual acts or displays that are not appropriate. Students who engage in PDA will be subject to intervention by staff and disciplinary action will be taken if this rule is blatantly and repeatedly broken.

STUDENT ONE -TO-ONE COMPUTER AGREEMENT

1. **Be Responsible for the Equipment** -- The student and parents/guardians agree to safeguard and take good care of the equipment to avoid any theft or damage. The student and parents/guardians will promptly report any loss, damage or problems with the equipment to the District. Damaged, lost, or stolen equipment will be fixed or replaced at the expense of the student and parents/guardians pursuant to Ohio law, including Revised Code Section 3313.642. Failure to pay for damaged, lost, or stolen equipment may result in the withholding of grades and credits and other consequences as permitted by law. By signing this document, you are committing to pay for any lost, damaged or stolen equipment.
2. **Use the Equipment for School Purposes Only** -- All use of the equipment by the student shall be for educational purposes only, pursuant to the Acceptable Use Policy. Students may only download apps and software as directed by the District.
3. **Follow the Acceptable Use Policy** -- The student and parents/guardians agree that all use of the equipment provided by the District will be in accordance with the District's Acceptable Use Policy ("AUP") and the Student Code of Conduct, and acknowledge that violations of that Policy or Code may lead to discipline and/or confiscation of the equipment. The student and parents/guardians agree to ensure that only the student who is issued the equipment and his/her teachers shall use the equipment (NOT any other person). The parents/guardians agree to supervise the student's use of the device at home in accordance with the District's AUP and Student Code of Conduct

4. **Follow Teacher Instructions Regarding the Equipment** -- Students are expected to bring the equipment to class fully charged and ready for use as directed by their teachers and may be required to purchase and bring their own earbuds/headphones. The student and parents/guardians understand that the student must not use the equipment when prohibited by District staff, such as during closed-book tests. Students must promptly comply with District staff directives to cease using, turn off, or put away the device. Failure to do so may lead to discipline and/or confiscation of the equipment.
5. **Return Equipment Upon Request** -- The students and parents/guardians agree that they will cooperate with the District regarding any maintenance, to be provided through the District, and that they will return all equipment to the District immediately upon request. The equipment must be returned immediately upon graduation from or withdrawal from the District; at the end of the school year; or upon request.
6. **Permit Monitoring/Inspection of Equipment** -- The equipment is the property of the District, and there is no right of privacy with regard to the equipment. The equipment and its contents, including browsing history, documents, pictures, files, and any other information or content on the equipment may be monitored and/or inspected at any time by the District.

CELL PHONE/ELECTRONIC COMMUNICATION DEVICES (ECD) - JUNIOR HIGH STUDENTS

NJHS Student Cell Phone Policy

1. NJHS students are not permitted to use cellular telephones during the school day with the exception of lunch. Parents/Guardians are advised that the best way to get in touch with their child during the school day is by calling the school office. Student possession of a cellular telephone is a privilege that may be forfeited if it is used/visible during the school day or on school-sponsored trips. Students may only turn on/use a cell phone with prior approval of the principal. Cell phones must be powered off and located inside of student school bags (in their locker) during the school day. Student cell phones may not be visible or used while classes are in session. Bus drivers may allow (at their discretion) students to use cell phones while riding to and from school. Distracting cell phone behavior that creates an unsafe environment on the school bus will not be tolerated. The school is not responsible for any cell phone that is lost or stolen.
 - 1st offense: Student cell phones will be confiscated by any staff member who sees it outside of a school bag. The staff member will label the cell phone with a note that includes the student's name and will then turn it in to the principal. It may be picked up by the student at the end of the day. The student will be given a cellphone violation warning from the principal.
 - 2nd offense: Student cell phones will be confiscated by any staff member who sees it outside of a school bag. The staff member will label the cell phone and then turn it in to the principal. The cell phone will be released/returned to the student's parent/guardian.
 - 3rd offense: Student cell phones will be confiscated by any staff member who sees it outside of a school bag. The staff member will label the cell phone and then turn it in to the principal. At this point, students will be disciplined for non-compliance. The student will receive additional consequences (i.e. after school Office Detention, Friday School, etc.). The cell phone will be released/returned to the student's parent/guardian after the student complies with any imposed disciplinary consequence.
2. **Refusal to Turn Over Cell Phone** - A student who refuses to turn over a cell phone to a staff member is subject to consequences including but not limited to Friday school, in school reassignment, out of school suspension, etc.
3. **Incoming Phone Calls for Students** - Incoming calls for students will be handled as follows:
 - Passes written for early dismissals will be delivered as needed.
 - Messages referring to after school activities will be delivered at the end of the day.
 - Emergency calls in which requests are made to talk to student during class will be handled by the principal.

4. Smart Watches Smart Watch (Fitbits, Apple watches, Samsung watches, and other wrist-worn devices may be worn at school. We allow students to wear these devices if they are used solely as a timekeeping device. If a student's smart watch is making noises, buzzing, the student is "swiping" or noticed utilizing it in any way other than checking the time at ANY time throughout the day, it will be treated as a cell phone and/or fall under our technology violations. Meaning, students may receive consequences and the watch will need to be kept in a book bag and powered off while on school grounds. All cell phone guidelines will then be put into effect for the e-watch. Please note that students are NOT permitted to wear these e-watches when we take our Ohio State Tests. Teachers may also require these devices to be put away students are working on any assignment/assessment. These guidelines may change depending on technology changes and if we have additional needs.

CELL PHONES/ELECTRONIC COMMUNICATION DEVICES (ECD) - HIGH SCHOOL STUDENTS

Students are permitted to use cell phones or mobile communication devices in the cafeteria and in between classes in a responsible manner. Students shall not make phone calls from their mobile communication device during the school day or during district provided transportation (i.e. bus or van transportation). Students may be permitted to use their cell phone or mobile communication device in the classroom if granted permission by a teacher, as long as the device does not create a distraction, disruption, or otherwise interfere with the educational environment and/or is for an educational purpose. If the device does create a disruption or distraction, staff reserves the right to confiscate the device for the remainder of the class period or day. Repeated violations may result in the loss of privilege of bringing a device to school. Students are responsible for knowing appropriate times to use technology.

1. No student shall use a cell phone or mobile communication device in violation of any student code of conduct, compute usage agreement, and/or bullying policy.
2. Students who are ill are expected to report immediately to the nurse. Students who call or text a parent/guardian requesting to be signed out from school due to illness without the consent of the nurse or building administration may result in an unexcused absence and/or discipline.
3. Students are prohibited from using mobile communication devices to capture, record or transmit the voice (i.e. audio) and/or images (i.e., pictures/video) of any student, staff member or other person in the school or while attending a school-related activity, without express prior notice and explicit consent for the capture, recording or transmission of such voice and/or images by all persons whose voice and/or image is captured. Using an ECD to take or transmit audio and/or pictures/video of an individual without his/her consent is considered an invasion of privacy and is not permitted, unless authorized by the building principal. Cameras may be used during sporting events and other public performances.
4. Examples of unacceptable usage of technology include but are not limited to: usage in bathrooms, locker rooms, and the natatorium, cheating, cyber bullying, and sexting.
5. Possession of a cell phone or other mobile communication device by a student is a privilege, which may be forfeited by any student who fails to abide by the terms of this policy, or otherwise engages in misuse of this privilege.
6. Parents may be contacted to claim the student's cell phone or other electronic device by a school administrator.
7. The contents of cell phones and/or mobile communications devices may be searched if reasonable suspicion exists that it was used in an activity prohibited by the code of conduct, technology policy, or computer usage agreement.

The student assumes all risks in bringing such devices onto school property or to school related functions.

DISCIPLINARY ACTIONS

1. **Detentions** -- Detentions may be assigned by any teacher or administrator. Parents/guardians shall be given 24 hour notice of the assigned detention. Students may be required to serve detentions before school (7:35 am-8:00 am), after school (3:05 pm-3:30 pm) on the date scheduled on the discipline slip, or an alternative time and date. Detentions are considered study times where sleeping or talking is not allowed. Detentions will be served with the individual who made the assignment unless other arrangements are made. A copy of the discipline slip should be forwarded to the administration.
2. **Emergency Removal** -- Emergency removal from a class will temporarily place a student in the office or out of school, if it is determined that the student possesses an on-going threat to the educational environment or process. A student may be unexcused from the classes missed during the removal. Due Process Rights can be found at www.napoleonareaschools.org > Board of Education > Board of Education Policies > 5611 Due Process Rights.
3. **Saturday School** -- Saturday School assignments may be made by an administrator. Saturday Schools are held from 8:30 a.m. to 11:30 a.m. Students must bring materials to study and arrive promptly. Parents/guardians will be notified by a phone call and/or mail by administration. An unexcused absence from Saturday School may result in an additional Friday/Saturday School(s), In-School Suspension, or Out-of-School Suspension being assigned.
4. **Friday School** -- Friday School assignments may be made by an administrator. Friday Schools are held from 3:15 p.m. to 6:15 p.m. Students must bring materials to study and arrive promptly. Parents/guardians will be notified by a phone call and/or mail by administration. An unexcused absence from Friday School may result in an additional Friday School(s), Saturday School(s), In-School Detention, or Out-of-School Suspension being assigned.
5. **In-School Reassignment (ISR)** -- An In-School Reassignment will result in the student not participating in regular classes or any other school activity during the period of the assignment. The assignment of an In-School Reassignment must be done by the administration. The school day(s) will be spent studying and working exclusively on academic work. Credit will be given for all school work completed during the assignment. Parents will be notified by phone and/or mail.
6. **Out-of-School Suspension (OSS)** -- An Out-of-School Suspension results in the denial of attendance and participation in any school activities. Students may be suspended from one to ten (1-10) days by the Principal or Assistant Principal. Progressive suspension may be given to students who continually break school rules and/or the code of conduct. Suspending students from classes is seen as a very serious penalty because days missed are considered unexcused. Due Process Rights can be found at www.napoleonareaschools.org > Board of Education > Board of Education Policies > 5611 Due Process Rights. If an Out-of-School Suspension is made:
 - a. Parents/guardians will be notified by mail. Courtesy calls by phone will be attempted,
 - b. Students may not attend classes, school functions, nor be on school property during the length of the suspension,
 - c. Credit will be given for school work completed during the suspension day(s)
7. **Expulsion** -- An expulsion may be done by the Superintendent for a continual or extreme breach of school policy. Expulsion may be as long as eighty (80) days or one calendar year and can be extended into the following school year. Due Process Rights can be found at www.napoleonareaschools.org > Board of Education > Board of Education Policies > 5611 Due Process Rights.
8. **Driver's License Suspension** -- A student's driver's license may be withdrawn by the Principal with driving privileges removed in accordance with Amended Substitute House Bill 204.
9. **School-Work Related Time** -- School-work related time is an option for students to work off their disciplinary consequences. This would be in lieu of the students being suspended Out-of-School. This option requires an agreement between administration and parents/guardians.

STUDENT DRESS CODE

The spirit of the dress code is to encourage an appropriate learning environment. Apparel worn to school should be clean and in a good state of repair – not torn or tattered. Athletic Department and coaches/advisors may require additional standards in the interest of safety. Also, the administration reserves the right to change the dress code to reflect changes in style. If a student violates the dress code, he/she may be asked to turn objectionable items inside out or remove the objectionable decal/button/insignia (if applicable). Students may be given school issued clothing to wear. If a change of clothing is required, the parent/guardian will be called to bring proper clothing. Students who violate the dress code may not be permitted to return to class until the situation is rectified. Any/all classes missed during this time will result in an unexcused absence. It is the student's responsibility to make every effort to follow the dress code. A student who violates the dress code may receive disciplinary action if blatantly or repeatedly in violation. School administrators will make the final decision on any questionable dress code item.

- All clothing must be worn modestly, in good taste, and adequate in length, coverage, and fit to be considered appropriate for a school educational setting.
- Any clothing that causes a disruption in the orderly functioning of the school is not permitted.
- Excessive jewelry or jewelry that could present a health and/or safety concern is not permitted.
- Apparel, patches, decals, insignia, buttons, or symbols that depict alcohol, drugs, tobacco, sex, gangs, violence, or foul/objectionable language, racism, discrimination, or any other inappropriate/illegal activity, as deemed by the administration, is prohibited.
- The American flag may not be worn inappropriately.
- Shorts, skirts, and dresses must be worn modestly, in good taste, and adequate in length, coverage, and fit to be considered appropriate for a school educational setting.
- Clothing shall be worn so that all undergarments remain covered at all times. See-through material is prohibited.
- Pants must be worn in good taste and at the conventional waistline with no sagging. Leggings (and other tight-fitting pants) are required to be opaque and worn in good taste. Pajama pants and other sleep-related items (such as blankets) are also not permitted to be worn as clothing.
- All shirts and tops must provide covered shoulders, a fully-covered back and midriff, and a modest neckline. Shirts must extend below the waistline when both standing and sitting.
- Clothing/jewelry that may cause injury to the wearer or others in class and lab or that may damage the building/equipment is not permitted. Shoes must be worn at all times.
- Hats, bandanas, masks costumes, and the like are not permitted to be worn during school hours except for designated spirit days. Hooded sweatshirts are permitted, but the hood must remain down at all times. Heavy coats and other outerwear are not be worn during regular school hours unless permission is obtained by school personnel.

TRANSPORTATION

All students are to understand that the bus driver is in charge of the bus at all times. The bus driver, at their discretion, has the right to assign seats and call parents concerning misconduct. Any student who repeatedly violates the safety precautions and/or conduct rules may be denied the privilege of riding the bus and is subject to other disciplinary action to be determined by the Principal and/or Transportation Supervisor. The following conduct rules are called to your attention:

1. Students must arrive at the bus stop 5 minutes before the bus is scheduled to arrive. The bus will not wait. Students must wait quietly in a location clear of traffic at the bus stop.
2. Student behavior at bus stops must not threaten life, limb or property of any individual.
3. Students must use correct crossing and loading procedures as instructed by the driver.
4. Students must go directly to an available or assigned seat.
5. Students must remain seated, keeping aisles and exits clear.
6. Students must observe classroom conduct and refrain from behavior that endangers other passengers. All school rules apply on the bus. Obey the driver promptly and respectfully.
7. Students must be courteous and respectful to fellow students and to the bus driver.
8. Students must not engage in loud talking or laughing, excessive horseplay, or fighting. Unnecessary confusion that diverts the driver's attention that might result in a serious accident.

9. Students must not use profane or abusive language.
10. Students must refrain from chewing gum, eating and drinking on the bus except as required for medical reasons.
11. Concerning tobacco, alcohol and drugs: students must not use or have in their possession, or have the odor of, on his/her breath, except for prescription medication required for the student.
12. Students must not have flammable and/or dangerous substances, fluids, weapons or illegal items on the bus. NO flammable items may be sprayed including cologne, body sprays, deodorant, etc.
13. Students must not throw or pass objects on, from or into the bus.
14. Students may carry on the bus only objects that can be held in their laps. No living creatures are permitted.
15. Students must treat bus equipment as one would treat valuable furniture in his/her home. Vandalism will not be tolerated. Keep the bus clean and sanitary.
16. Students must not tamper with emergency doors, windows or equipment.
17. Students must not extend any part of their bodies out of the bus windows.
18. Students are to remain absolutely quiet at railroad crossings until the bus has completely crossed and the driver says it is OK to talk.
19. Students must ride their assigned bus and must board/exit at assigned locations unless they have written parental and administrative authorization to do otherwise.

NOTICE OF NONDISCRIMINATION & INTERNAL COMPLAINT PROCEDURES

Any form of discrimination or harassment can be devastating to an individual's academic progress, social relationship and/or personal sense of self-worth. As such, the Board of Education does not discriminate on the basis of race, color, national origin, sex (including sexual orientation or transgender identity), disability, age (except as authorized by law), religion, military status, ancestry, or genetic information (collectively, "Protected Classes") in its educational programs or activities. The Board also does not discriminate on the basis of Protected Classes in its employment policies and practices as they relate to students, and does not tolerate harassment of any kind. Equal educational opportunities shall be available to all students, without regard to the Protected Classes, age (unless age is a factor necessary to the normal operation or the achievement of any legitimate objective of the program/activity), place of residence within the boundaries of the District, or social or economic background, to learn through the curriculum offered in this District. Educational programs shall be designed to meet the varying needs of all students. An individual who believes s/he has been unlawfully discriminated/retaliated against may make an informal complaint, either orally or in writing: (1) to a building administrator; (2) directly to the Complaint Officer; and/or (3) to the Superintendent or other District-level employee.

ATTENDANCE POLICIES AND PROCEDURES

The State of Ohio (Ohio Revised Code 3321.01) states that all persons between the ages of six and 18 must attend school. Napoleon High School is bound by the Ohio Revised Code and the Missing Children Act. Since school attendance is vital to the academic success of each student, we believe that 100% attendance should be the goal of each student and parent/guardian.

1. Attendance Procedures

- a. The Napoleon Junior/Senior High School doors open at 7:45 a.m., and students will remain outside until then or report immediately to the cafeteria, unless under the direct supervision of a staff member.
- b. Parents/guardians should notify the school at 419-599-1050 by 8:30 a.m. each day that the student is absent, unless previously arranged with administration. If NO parent/guardian contact is made, an auto call, text and/or email will be sent regarding the student's absence.
- c. If a student is absent/tardy the student is required to have a phone call or written note from a parent or the required documentation turned in to the office immediately upon returning to school. When no documentation is provided, the absence may be UNEXCUSED.
- d. Students who are late to school, or those who must leave early and/or return from an appointment, must go to the office immediately upon arrival at school. Parents/ guardians are asked to schedule appointments outside of the school day whenever possible. If this is not possible, students should only miss travel time and the appointment. Also, if the student can leave or return between class periods, it reduces distractions to the learning environment.

- e. 18 year old students are expected to follow the same procedures for attendance as students who are under 18 (unless no longer under the care physically nor financially of their parents). Students no longer under the care of their parents must petition the assistant principal/attendance officer to be granted independent student status.

2. Absences

- a. Students are permitted 6 absences per semester with a parent note/phone call.
- b. After the 6th absence, students will require doctor's notes, funeral cards or legal notices in order to be excused.
- c. Students who reach **6 days of UNEXCUSED absence in a semester** may lose credit for the semester.

3. Notifications

- a. Students and parents will be notified by letter when a student reaches **3 days of absence (whether those absences are excused/unexcused)** in a semester.
- b. Students and parents will be notified by letter when a student reaches **6 days of absence (whether those absences are excused/unexcused)** in a semester. Additional documentation (dr. note, funeral card, or legal notice) is then required for any further absences that semester.
- c. Students who reach a level of **6 UNEXCUSED absences in 1 semester** will be notified of suspension of credit and will be expected to complete a credit reinstatement request. This request should be accompanied by any further documentation for the absences in question.
- d. The law requires that parents of ALL STUDENTS who reach a level of **6 days of absence (38 hours) in 1 month 10 days in a school year (65 hours) with or without legitimate excuse** will be given written notice of those absences. Interventions for absences may be instituted (Ohio Revised Code Sec. 3321.191 (C)(1)).

4. Excused Absences (In cases needing documentation, the school must receive documentation within 5 days of returning to school.)

- a. Personal illness with documentation of medical excuse
- b. Illness in the immediate family
- c. Death of an immediate relative
- d. Observance of religious holidays
- e. Court appointment with documentation
- f. College visitations/military appointments

5. Unexcused Absences (May result in official warnings for school truancy, intervention plan and services, or court referral.)

- a. Employment other than school approved
- b. Oversleeping
- c. Missing the bus
- d. Hair appointments
- e. Car trouble
- f. Individual recreation trips
- g. Leaving the building during the day without permission
- h. Any other absences deemed as unexcused by administration

6. Tardiness

- a. Students are expected to arrive at school and to each of their classes on time. Students who are late to school in the morning are to report immediately upon arrival to the main office. Students will sign in and receive a tardy slip before reporting to class. Students arriving after 10:00 a.m. will be classified as absent.
- b. After the 3rd unexcused tardy to school, and every tardy after the first three, the student may be assigned a Friday School, in-school suspension, or other consequence/intervention assigned by administration.

- c. Failure to attend an assigned Friday School may result in additional assignments to Friday school or assignment to in-school suspension.
- d. Excessive **UNEXCUSED** tardiness may result in any of the actions outlined in the truancy section.

7. Early Dismissal

- a. Students are required to sign out in the High School office when leaving the school property. They **MUST** have permission from a parent, in order to be allowed to leave.
- b. Students leaving prior to 1:30 p.m. will be considered absent one half day either excused or unexcused.
- c. Ill students must report to the nurse when feeling ill. The nurse will make contact with a parent/guardian to arrange dismissal.

8. Vacations

- a. Vacations are encouraged to be taken during the summer or during scheduled breaks (Thanksgiving, Winter Break, Spring Break, etc).
- b. School personnel acknowledge vacations, but they are not approved or disapproved. As with illness, students are expected to stay within the school's parameters of attendance/number of days missed (no more than 6 absences per semester).
- c. All vacations occurring when classes are in session require the completion of a vacation request form. Forms can be obtained either online or from the main office.
 - i. Vacation request forms must be completed at least 1 week before the intended leave date. Extended notice is encouraged and appreciated.
 - ii. **Should a vacation result in a student going over their 6 discretionary days, the student's absences may not be excused. If the absences are unexcused, it is at the teacher's discretion to award credit.**

9. Make Up Work (excluding vacations – which is outlined above)

- a. Make up work is the responsibility of the student who should contact each teacher personally. Students will be allowed the same number of days to make up their work as the number of days missed, in cases of extended illness, special arrangements may be made.
- b. When absences are **UNEXCUSED**, students are to make up all missed work. If students are over their allotted days, it is at the teacher's discretion to award credit.

10. Loss of Credit

- a. Students who reach 6 days of **UNEXCUSED** absence in 1 semester may lose credit for that semester.
- b. Parents/students will receive a letter stating the student has reached the level of 6 **UNEXCUSED** days of absence, along with a "Reinstatement of Credit Application."
- c. Students must turn the "Reinstatement of Credit Application" within 1 week of its receipt and attach any supporting documents for the reason for the absences that were marked unexcused.

11. Procedure for Reinstatement

- a. An attendance audit will be conducted by the assistant principal, attendance officer and any other appropriate staff to determine whether credit should be reinstated based on the documentation provided.
- b. Lack of documentation may result in a meeting with all parties to formulate a plan to make up the appropriate amount of time associated with loss of credit in each course affected. Any of the following options being implemented to reinstate credit:
 - i. Using before and after school time with teacher(s) to make up lost time
 - ii. Use of Friday Schools provided by the school for the purpose of making up time
 - iii. Any other creative option agreed to by the consensus of the team.

12. Truancy

- a. Truancy is defined as follows: Absence from school without legitimate excuse.
- b. Students who accumulate unexcused absences may be subject (but not limited to) the following:
 - i. Official warnings to student/parent for school truancy issues
 - ii. Interventions
 - iii. Mediation
- c. Habitual truancy will be dealt with in accordance to Ohio Revised Code 3321
 - i. Interventions
 - ii. Court referral (charges can be brought against the student and the parent)
 - iii. Student's suspension of driver's license

SCHOOL ATTENDANCE IN SUMMARY

Excused absences are just as problematic as unexcused ones.

1. Research shows that students who miss 10% of school (2 days per month) show negative academic progress.
2. Students who miss 2 days of school each month, miss almost a month of school each year. This adds up to over a year missed by the time of graduation.

(American Graduate: Every Day Counts: Fact on Attendance, Achievement 9/3/2015)

SCHOOL PROCEDURES

STUDY HALLS

A study hall is to complete homework, study school-related material, prepare for tests, or do reading. The following rules shall apply:

1. Students are to be in an assigned seat.
2. No talking is allowed without permission of the study hall monitor
3. No eating.
4. Hall/restroom passes are at the discretion of the study hall monitor. The student's agenda must be signed to allow leaving the study hall.
5. Pre-signed agendas/passes must be presented to the study hall monitor within the first five (5) minutes of the period.
6. Students are to leave the room NEAT for the next class and PUSH their chairs under the table when they leave.
7. Technology use in study hall should be strictly for an educational purpose.

ASSEMBLIES AND PROGRAMS

Assemblies will be held periodically to provide various programs for students. Students should move quickly and quietly to the designated area and are expected to conduct themselves as mature young adults. Behavior is a reflection on the individual, parents/guardians, and school. Common courtesy demands the full attention of all students with cell phones put away or powered off. Improper action, talking, noise, inappropriate technology use, etc. will result in the loss of assembly privileges and may result in additional disciplinary action. The person in charge of the assembly will dismiss students to resume the class schedule.

2022-2023 - DISTRICT CALENDAR

July 4	Holiday Observed
Aug. 18	New Teacher Orientation
Aug. 19	P.D./IAT Day
Aug. 22	Breakfast/P.D. Day
Aug. 23	Teacher Work Day
Aug. 24	Students' First Day
Sept. 5	Labor Day (No School)
Oct. 10	P.D. Day – No students
Oct. 28	End of the 1st Nine Weeks
Nov. 8/10	Parent/Teacher Conf - Evening
Nov. 11	Parent/Teacher Conf – No Students
Nov. 23-25	Thanksgiving Break (No School)
Dec. 21 - Jan. 3	Christmas Break (No School)
Jan. 12	End of 2nd Nine Weeks
Jan. 13	Teacher Work Day – No Students
Jan. 16	MLK Day – No Students/No Staff
Feb. 20	President's Day (No School)
Mar. 17	End of 3rd Nine Weeks
Apr. 7-10	Easter Break – No Students/No Teachers
May 25	Last Student Day
May 26	P.D. Day
May 28	Graduation
May 29	Memorial Day
May 30	Teacher Work Day
Make Up Days	May, June - TBA



2022-2023 - BELL SCHEDULES

TRADITIONAL SCHEDULE - MONDAY, TUESDAY, & FRIDAY

8:05	Warning Bell
8:10	Tardy Bell
8:10 – 8:54	First Period
8:58 – 9:40	Second Period
9:44 – 10:26	Third Period
10:30 – 11:12	Fourth Period
11:16 – 11:42	Fifth Period/A Lunch
11:46 – 12:12	Fifth Period/B Lunch
12:16 – 12:42	Fifth Period/C Lunch
12:46 – 1:28	Sixth Period
1:32 – 2:14	Seventh Period
2:18 – 3:00	Eighth Period

TRADITIONAL SCHEDULE TWO HOUR DELAY

10:05	Warning Bell
10:10	Tardy Bell
10:10 – 10:35	First Period
10:39 – 11:04	Second Period
11:08 – 11:33	Third Period
11:37 – 12:03	Fifth Period/A Lunch
12:07 – 12:33	Fifth Period/B Lunch
12:37 – 1:03	Fifth Period/C Lunch
1:07 - 1:33	Sixth Period
1:37 – 2:02	Fourth Period
2:06 – 2:31	Seventh Period
2:35 – 3:00	Eighth Period

BLOCK SCHEDULE

Wednesday B1 Day (Periods 1, 3, 5, & 7)

Thursday B2 Day (Periods 2, 4, 6, & 8)

8:05	Warning Bell
8:10-9:30	First Period (B1)/ Second Period (B2)
9:34-10:54	Third Period (B1)/ Fourth Period (B2)
10:54-12:58	Fifth Period (B1)/ Sixth Period (B2) • A Lunch (10:54-11:28) • B Lunch (11:24-11:58) • C Lunch (11:58-12:28)
1:02-1:36	Intervention/Enrichment (I/E)
1:40-3:00	Seventh Period (B1)/ Eighth Period (B2)

BLOCK SCHEDULE TWO HOUR DELAY

Wednesday B1 Day (Periods 1, 5, 3, & 7)

Thursday B2 Day (Periods 2, 6, 4, & 8)

8:05	Warning Bell
10:10-11:04	First Period (B1)/ Second Period (B2)
11:04-1:08	Fifth Period (B1)/ Sixth Period (B2) • A Lunch (11:04-11:38) • B Lunch (11:34-12:08) • C Lunch (12:04- 12:38)
1:12-2:04	Third Period (B1)/ Fourth Period (B2) * No Intervention/ Enrichment
2:08-3:00	Seventh Period (B1)/ Eighth Period (B2)

ASSEMBLY

8:05	Warning Bell
8:10	Tardy Bell
8:10 – 8:54	First Period
8:58 – 9:40	Second Period
9:44 – 10:26	Third Period
10:30 – 11:12	Fourth Period
11:16 – 11:42	Fifth Period/A Lunch
11:46 – 12:12	Fifth Period/B Lunch
12:16 – 12:42	Fifth Period/C Lunch
12:47 – 1:21	Sixth Period
1:25 – 2:01	Seventh Period
2:05 – 2:39	Eighth Period
2:40 – 3:00	Assembly – dismissal via P.A.

ONE HOUR DELAY

9:05	Warning Bell
9:10	Tardy Bell
9:10 – 9:42	First Period
9:46– 10:18	Second Period
10:22 – 10:58	Third Period
11:02 – 11:36	Fourth Period
11:40 – 12:06	Fifth Period/A Lunch
12:10 – 12:36	Fifth Period/B Lunch
12:40 – 1:06	Fifth Period/C Lunch
1:10 – 1:40	Sixth Period
1:44 – 2:22	Seventh Period
2:26 – 3:00	Eighth Period

CONCEALED CARRY LAW

Unless otherwise authorized by law, pursuant to Ohio Revised Code no person shall knowingly possess, have under his or her person's control, convey, or attempt to convey a deadly weapon or dangerous ordnance into a school safety zone.

LOCKS AND LOCKERS

Each student is assigned a locker and is responsible for everything that is put into that locker. Students should NOT share lockers with other students. Lockers should remain locked at all times when not immediately in use. Since the locker is the property of the District, there is no expectation of privacy. Students are NOT allowed to make any unauthorized locker changes. If changes need to be made, students should notify the staff in the Junior/Senior High School office. Only school locks may be placed on any school locker. Do not write, mark, or inappropriately decorate a locker. The Junior/Senior High School administration reserves the right to search lockers and their contents to ensure the safety of students in the building or for any other reason deemed necessary.

SEARCH AND SEIZURE

In accordance with Napoleon Area City School's Board Policy 5771, Administrators may search a student or his/her property (including vehicles, purses, backpacks, bags, etc.) with or without the student's consent, whenever they reasonably suspect that a search will lead to the discovery of evidence of a violation of law or school rules. Student lockers are the property of the district and students have no reasonable expectation of privacy in their content or in the contents of any other district property including desks or other containers. School authorities may conduct random searches of lockers, desks, cabinets, etc. and their contents at any time without announcement. Unannounced and random canine searches may also be conducted. Anything that is found in the course of a search may be used as evidence of a violation of school rules or the law, and may be taken, held, or turned over to the police. The school reserves the right not to return items that have been confiscated.

RESTROOMS

Students are not permitted to loiter in the restrooms at any time. Students must use their official passes when using the restroom during class time. No more than one student shall occupy a stall at any time for those stalls intended for one person. If a student becomes ill while in the restroom, the student should report immediately to their teacher, main/guidance office, and/ or nurse's clinic. Napoleon Area City Schools allows students equal access to restrooms in accordance with relevant law.

BOOK BAGS AND PURSES

Carrying book bags and/or a purse large enough to hold a book in school during the school day is not permissible. Students may bring them to school, but they must be stored in one's assigned locker upon arrival to school.

VISITORS

All visitors should report to the main school office immediately after entering the building. Office personnel will ask for the names of visitors, reason(s) for the visit, and/or personal identification. Visitors are expected to sign in and out. Also, visitors may be required to wear a special visitor badge.

Students are not permitted to bring visitors into the Junior/Senior High School during the school day. Special cases may be approved with at least 48 hours prior notice to the administration.

EIGHTEEN YEAR OLD STUDENTS

State law identifies 18 years of age as being the age of majority, or in other words, 18 year-olds enjoy adult status in our society. State law also requires that all students (regardless of age) adhere to school rules and regulations. Consequently, an 18 year-old student (living at home) would be required to have parental permission for all activities that would require parental permission of the non-18 year-old student. This is also true of school mailing or notification.

AUTOMOBILES AND STUDENT PARKING

Licensed Napoleon Junior/Senior High School students enjoy the privilege of driving to school and parking in the student parking lot. **NO PARKING IS ALLOWED ON WILDCAT DRIVE.** Student parking is also not permitted in the staff, visitor, or Board of Education parking lots. To avoid the enforcement of additional limitations and restrictions, High School students who drive to school **MUST** park within a designated parking spot in the student parking lot at all times of the day and year, including before and after school, and/or vacation/weekend. If administration suspects illegal contraband or has other reasonable suspicions, searches of vehicles on school property may be conducted. Students must leave their vehicles immediately upon arriving at school and shall not return to them until dismissal. Reckless or unauthorized operation of a motor vehicle and/or parking in an unauthorized area may result in disciplinary action and/or loss of privileges. Driving privileges may be withdrawn at any time. The administration asks for student cooperation to set an example for all visitors, guests, and each other.

LUNCH

All students must eat in the Junior/Senior High School Cafeteria. Students may not eat outside of the Cafeteria without the permission of the administration. Students will be expected to behave with respect and dignity while in the Cafeteria. Directions given by the Cafeteria staff and/or monitors must be obeyed at all times. Students may bring a packed lunch but it must be brought in at the beginning of the day. Food may also be bought in the cafeteria. **DELIVERIES OR SPECIAL ORDERS OF FOOD WILL NOT BE ALLOWED.**

ACADEMIC INFORMATION

STUDENT SCHEDULES

All students will register in the spring for the following school year. Information about scheduling and registration will be explained by the Guidance Department. Students must also consider state and local graduation requirements as well as those of their considered colleges when scheduling every class. Schedules may be changed only with the permission of parents, teacher(s), counselor, and administration. With the exception of special circumstances, all changes must be made within the first three days of the semester. All subjects dropped after that may receive a "Withdrawal Failure" (WF) for the semester. The administration will consider parental/guardian requests and recommendations regarding student scheduling. School officials will make the final decision as it pertains to each child's course offerings, times, locations, and placement during the academic day.

The Board of Education recognizes that the personal, social, physical, and educational growth of children will vary and that they should be placed in the educational setting most appropriate to their needs at the various stages of growth. Student promotion, academic acceleration, placement, and retention are defined according to Board of Education Policy #5410.

COLLEGE CREDIT PLUS PROGRAM (CCP)

The College Credit Plus program gives college-bound high school students the opportunity to earn college credit and high school credit simultaneously. This gives students the advantage of starting the transition to college early, while reducing the cost and length of time needed to graduate once they enroll in college. High school students can take part in the college experience, interacting with full-time college students and university faculty, while experiencing the rigor of college-level courses. Courses may be taken face-to-face at a college campus, online, or here at NHS for specific courses.

Students should see their guidance counselor for detailed information pertaining to eligibility requirements in order to participate in CCP. Students and parents who are interested must attend an annual informational meeting held at NHS where they will obtain an informational packet, sign the intent to participate, and have the opportunity to meet with high school counselors and college admissions officers. The intent to participate form must be submitted no later than April 1.

GRADING SYSTEM

GRADE POINT AVERAGE AND CLASS RANK

All courses receiving High School credit will be used to compute a student's grade point average and class rank. One unit of A=4.0, B=3.0, C=2.0, D=1.0, F=0.0. Point value variations will occur in the 4.0 scale based upon the status of a letter grade with a "+", only the letter grade, or the letter grade with a "-" as earned. In addition, students will receive additional or weighted grades for Honors or Advanced Placement courses. Students are ranked at the end of each semester. The cumulative grade point average and rank at the end of each school year are recorded on the student's official transcript.

	Range	Regular	Honors	AP
A+	97-100	4.0	4.5	5.0
A	93-96	4.0	4.2	4.5
A-	90-92	3.8	4.0	4.2
B+	87-89	3.5	3.8	4.0
B	83-86	3.2	3.5	3.8
B-	80-82	2.8	3.0	3.5
C+	77-79	2.5	2.8	3.2
C	73-76	2.2	2.5	2.8
C-	70-72	1.8	2.2	2.5
D+	67-69	1.5	1.8	2.2
D	63-66	1.2	1.5	1.8
D-	60-62	1.0	1.2	1.5
F	0-59	0.0	0.0	0.0

Requirements for Graduation

State law introduced new, permanent graduation requirements for students in the class of 2023 and beyond. Student entering ninth grade after July 1, 2019, must meet the new requirements outlined in state law.

The new graduation requirements can be found at www.napoleonareaschools.org > Board of Education > Board of Education Policies > 5460 Graduation Requirements. Requirements may also be viewed on the Ohio Department of Education website at <http://education.ohio.gov/Topics/Ohio-s-Graduation-Requirements>.

FEES

All students are responsible for paying required fees for items such as workbooks, labs, fines, etc. Final exams, grade cards, and the diploma will be withheld until all financial and other school-related obligations are met. Also, students will not be assigned any Board-owned property (textbooks, etc.) until the required fees or debts are paid from the previous school year or semester.

PARTICIPATION IN SCHOOL-RELATED FUNCTIONS

For school-related functions such as visiting with college recruiters, field trips, performances, and competitions, the administration reserves the right to deny participation if the student is in poor academic standing.

GENERAL INFORMATION APPROVAL OF EVENTS

All events must be approved by the administration and entered on the Master Calendar located in the Main School Office. Fundraisers, meetings, dances, concerts, field trips, assemblies, and other school-related activities must be authorized by the administration and recorded.

EMERGENCY MEDICAL FORMS

Emergency medical forms are required by Ohio law and must be on file for immediate access in case of injury. These must be on file by the Friday of the second full week of school. Disciplinary action may result for failure to submit emergency medical forms.

MEDICATION GUIDELINES

If possible, all medications should be given at home. The school nurse will supervise the secure and proper storage/dispensing of both prescription and non-prescription medication. The use of either without the written permission of a parent/guardian is prohibited.

FIRE, TORNADO, AND SAFETY DRILLS

Students should know the fire drill exits from all rooms where they attend classes. During fire drills, the building should be left in a quiet and orderly fashion within a minimum amount of time. Students should exit without excessive noise. Running or shouting will not be permitted.

Students should also learn the procedures for tornadoes, severe weather, and safety situations for each of their classrooms. The general rule for tornadoes and severe weather is to stay away from doorways and windows. Students should crouch on their knees and cover their heads with their hands. Safety drills whether a building lockdown or evacuation should also be learned by students for each of their classrooms. Each fire, tornado, or safety drill should be taken seriously with the understanding that it may not be a practice.

TELEPHONE USE BY STUDENTS

A telephone is available in the high school office for emergency purposes. Students should request permission from high school office staff or administration to use the telephone.

COMPUTER USE

Before any student may log into the district owned Wi-Fi or use any of the various computers located on school property or with district owned resources, a Computer Systems and Internet Safety User Agreement and Parent/Guardian Agreement must be signed by each student and parent/guardian, usually done at the end of the 8th grade year prior to coming to Napoleon High School, or as a new student to the district.

WEATHER RELATED ANNOUNCEMENTS

Tune into WNDH-103.1FM, and other local media for announcements regarding delays, postponements, and cancellations.

LIBRARY MEDIA CENTER (LMC)

The Napoleon Junior/Senior High School Library Media Center is open to all students and staff members. All are encouraged to use the LMC and ask the Media Specialist for assistance when necessary. LMC resources are circulated for a three-week period and may be renewed by returning them to the LMC for renewal.

Library sign-in from study hall must be done immediately upon entering the library at the beginning of a study hall period. Students must sign-in electronically via an iPad or other electronic device provided by the Media Specialist. Students coming on a pass should present their library pass to the Media Specialist on duty immediately upon arrival. The number of students using the LMC from study halls may be limited.

Rules to be followed in the LMC include:

1. Students must be studying and working. Quiet conversation is permitted at the discretion of the teacher.
2. Students are to treat all resources, equipment, and furniture with care and consideration. Any infraction of LMC rules and procedures may result in study hall sign-in privileges being revoked.

ATHLETICS/ACTIVITIES

ELIGIBILITY

The Napoleon Area School District's Board of Education has approved the following academic eligibility requirements for students who want to participate in extracurricular activities at the High School.

1. In order to be eligible in grades 7-12, a student must be currently enrolled and must have been enrolled in school the immediately preceding grading period. For the purpose of this Bylaw 4, Section 4, the term "grading period" is defined as the school's Board-adopted calendar (e.g., six week, nine week, 12 week or semester) and does not mean an interim marking period. Furthermore, during the preceding grading period, the student must have received passing grades in a minimum of five (5) one-credit courses or the equivalent, each of which counts toward graduation in grades 7-12; and four (4) one-credit courses or equivalent in grades 7 & 8. For the purpose of this bylaw, the term "immediately preceding grading period" refers to the grading period of the school which immediately precedes the grading period in question.
2. A student under disciplinary action, whose conduct or character reflects discredit on the school, may be ruled ineligible by the administration.

STUDENT DRUG/ALCOHOL TESTING POLICY

In an effort to promote a safe and drug-free/alcohol-free school environment at Napoleon Junior/Senior High School, students who participate in co-curricular or extracurricular activities may be required to consent to Napoleon Area School's Student Drug Testing Policy in order to become eligible for participation.

ATHLETIC/ACTIVITY REQUIREMENTS

1. To participate in any extra-curricular activities, each student must have:
 - a. Record of a current medical physical examination on file
 - b. Adequate medical insurance to cover expenses if an injury or a waiver stating medical insurance coverage
 - c. Student and parent/guardian consent by a signed Code of Conduct
 - d. Emergency medical form on file.
2. To *attend, participate, and/or practice* in any activity before or after school, the student must attend five (5) full periods on a traditional schedule day and two (2) full periods on a block schedule day, unless approved by the administration or disciplinary action will be taken.
3. Custodial papers on file with the local juvenile court must also be on file in the High School Guidance Office for any student living with someone other than natural parent/guardian.

ATHLETIC CODE OF CONDUCT

Participation in extra-curricular activities, including athletics, is a privilege, not a right. Student-athletes in extra-curricular activities are in a highly visible setting of leadership and/or competition/performance. Thus, the student-athlete will be held to a higher standard of conduct and behavior than one who chooses neither to participate nor represent Napoleon Area City Schools. The student-athlete should ALWAYS be a responsible individual and bring pride to him/herself, the school, and community. Furthermore, our young men and women athletes are role models for younger children. This responsibility is a year round commitment and does not end with the school year. Therefore, these rules (the "Code of Conduct") are in effect all four years of a student's high school career or all years of a student's middle school career and are enforced all 12 months of the year beginning on the date adopted by the Napoleon Area City School Board of Education (the "Board"). Support and encouragement from parents to ensure that student-athletes abide by these rules is vital. The athletic code of conduct in its entirety is available on The Napoleon Area City Schools Website.

Students who do not abide by the rules of Napoleon Junior/Senior High School will face consequences for their actions. In addition, students who damage school or personal property, either accidentally or purposefully will be held responsible for paying for the damages. Students who violate the discipline code and are removed/suspended may be required to receive counseling before returning to school.

EXTRA-CURRICULAR ACTIVITIES

Napoleon Junior/Senior High School offers a wide variety of extra-curricular activities including varsity, club, and intramural sports. The following are available after school hours:

CO-CURRICULARS CLUBS/ACTIVITIES

Student Advisory Board (ABC)	National Honor Society
Athletic Assistant Trainer	Quiz Bowl
DECA (Marketing)	Envirothon
Spanish Club	French Club
HIOY	Jazz Choir
N Club	Student Council
Thespian Club	Art Leag
Speech	Jazz Band
Jazz Choir	Student Class Officers

VARSITY & CLUB SPORTS

Baseball	Softball
Basketball	Soccer
Bowling	Swimming
Cheerleading	Tennis
Cross Country	Track & Field (Indoor & Outdoor)
Diving	Volleyball
Football	Water Polo
Golf	Wrestling
Gymnastics	Esports
Drone Racing	

INTRAMURAL SPORTS

Basketball	Volleyball
------------	------------

NCAA

Students may qualify to participate in Division I or II college athletics and also must meet with the Athletic Director by May of their junior year to register with the NCAA Clearinghouse.



15 MONDAY

9:00 AM - 9:30 AM - Varsity Boys Golf vs Patrick Henry High School / Middle School and 18 others (A)
 9:00 AM - 10:00 AM - Varsity Girls Golf vs Lady Trojan Invite (11 Participants) (A)
 4:30 PM - 6:30 PM - Varsity Girls Tennis vs Archbold High School (A)

AUGUST

hinterland n. -- a region removed from urban areas. The family moved out of the city to the hinterland.

16 TUESDAY

4:30 PM - 6:30 PM - Varsity Girls Tennis vs Ottawa Hills Junior/ Senior High School (A)

AUGUST**17 WEDNESDAY**

9:00 AM - 11:00 AM - Varsity Girls Golf vs Miller City HS/MS - Girls Varsity Golf (A)

AUGUST**18 THURSDAY**

4:30 PM - 5:30 PM - Varsity Boys Golf vs Liberty Center High School/ Middle School (H)
 4:30 PM - 5:30 PM - Varsity Girls Golf vs Liberty Center High School/ Middle School (H)

AUGUST

19 FRIDAY

7:00 PM - 10:00 PM - Varsity Boys
Football vs Defiance High School
(H)

AUGUST

-cad-, -cas- (to fall) – decadent, cadence, accident, cascade

20 SATURDAY

10:00 AM - 12:00 PM - Junior Varsity
Boys Football vs Defiance High
School (A)

AUGUST

21 SUNDAY

AUGUST

**QUOTE OF
THE WEEK**

“No bird soars too high if he soars with his own wings.” – William Blake

NOTES

22 MONDAY

9:00 AM - 1:00 PM - Varsity Boys Golf vs District Preview (12 Participants) (A)
 4:30 PM - 7:15 PM - 7/8th Girls Volleyball vs junior high volleyball game (Arbor Hills Junior High School) (H)

AUGUST

flag v. – becoming weak; droop. The team’s spirit was flagging toward the end of the game.

23 TUESDAY

4:30 PM - 7:00 PM - Varsity Girls Golf vs Defiance High School (A)
 5:00 PM - 7:00 PM - Varsity Boys Soccer vs Miller City HS/MS (A)
 5:30 PM - 7:00 PM - Varsity Coed Cross Country vs Upper Sandusky High School Icebreaker Cross Country Invitational (17 Participants) (A)
 7:30 PM - 9:00 PM - Junior Varsity Boys Soccer vs Miller City HS/MS (A)

AUGUST

24 WEDNESDAY

4:30 PM - 7:30 PM - Varsity Girls Tennis vs Fostoria Junior/Senior High School (H)

AUGUST

25 THURSDAY

7:00 PM - 8:30 PM - Varsity Girls Soccer vs Ottawa Hills Junior/Senior High School (A)

AUGUST

26 FRIDAY

7:00 PM - 9:30 PM - Varsity Boys Football vs Liberty Center High School/Middle School (A)

-cap-, -cip- (head) – decapitate, captain, capital

AUGUST

27 SATURDAY

8:30 AM - 2:30 PM - Varsity Boys Cross Country vs Seneca East - The Tiger Classic - HS Boys (87 Participants) (A)
8:30 AM - 2:30 PM - Varsity Girls Cross Country vs Seneca East - The Tiger Classic - HS Girls (89 Participants) (A)
9:00 AM - 1:00 PM - Varsity Coed Cross Country vs DEFIANCE EARLY BIRD X-C OPEN (24 Participants) (A)
10:00 AM - 11:00 AM - Junior Varsity Boys Football vs Liberty Center High School/Middle School (H)

AUGUST

28 SUNDAY

AUGUST

QUOTE OF THE WEEK

“It is best to learn as we go, not go as we have learned.” – Leslie Jeanne Sahler

NOTES

29 MONDAY

4:30 PM - 6:30 PM - Varsity Boys Golf vs Wauseon High/Middle School (H)

belfry n. – bell tower. Several times a year, the church belfry needed to be cleaned of cobwebs.

AUGUST

30 TUESDAY

4:15 PM - 7:00 PM - 7/8th Girls Volleyball vs jh volleyball game (Tinora High/ Junior High School) (H)
4:30 PM - 6:30 PM - Varsity Girls Tennis vs Anthony Wayne High School (A)
4:45 PM - 5:45 PM - Freshman Girls Volleyball vs Springfield High School (Holland) (A)
5:00 PM - 6:30 PM - Junior Varsity Boys Soccer vs Sylvania Southview High School - JV (A)
5:45 PM - 6:45 PM - Junior Varsity Girls Volleyball vs Springfield High School (Holland) (A)
6:45 PM - 8:45 PM - Varsity Girls Volleyball vs Springfield High School (Holland) (A)
7:00 PM - 9:00 PM - Varsity Boys Soccer vs Sylvania Southview High School (A)

31 WEDNESDAY

4:30 PM - 6:15 PM - 7th Boys Football vs 7th grade football (McCord Junior High School) (H)
4:30 PM - 7:30 PM - 7/8th Coed Cross Country vs Eastwood Flying Eagle JH Cross Country Invite (23 Participants) (A)

AUGUST

1 THURSDAY

4:30 PM - 6:30 PM - Varsity Girls Tennis vs Bowling Green High School - OH (H)
4:45 PM - 5:45 PM - Freshman Girls Volleyball vs Perrysburg High School (H)
5:00 PM - 7:00 PM - Freshman Boys Football vs Bowling Green High School - OH (H)
5:45 PM - 6:45 PM - Junior Varsity Girls Volleyball vs Perrysburg High School (H)
6:45 PM - 8:45 PM - Varsity Girls Volleyball vs Perrysburg High School (H)
7:00 PM - 9:00 PM - Varsity Girls Soccer vs Liberty Center High School/Middle School (H)

SEPTEMBER

5 MONDAY

Labor Day

SEPTEMBER

quash v. – crush; suppress. Her dreams of medical school were quashed when she failed her entrance exams.

6 TUESDAY

4:30 PM - 5:00 PM - 7/8th Girls Volleyball vs Liberty Center High School/Middle School (A)
4:45 PM - 5:45 PM - Freshman Girls Volleyball vs Anthony Wayne High School (A)
5:00 PM - 6:00 PM - Varsity Coed Cross Country (A)
5:00 PM - 7:00 PM - Junior Varsity Boys Soccer vs Anthony Wayne High School - JV (A)
5:45 PM - 6:45 PM - Junior Varsity Girls Volleyball vs Anthony Wayne High School (A)
6:20 PM - 7:00 PM - 7/8th Coed Cross Country (A)
6:45 PM - 8:45 PM - Varsity Girls Volleyball vs Anthony Wayne High School (A)
7:00 PM - 9:00 PM - Varsity Boys Soccer vs Anthony Wayne High School (A)

SEPTEMBER

7 WEDNESDAY

4:30 PM - 6:00 PM - 7/8th Coed Cross Country vs Cross Country Meet (2 Participants) (A)
4:30 PM - 6:15 PM - 8th Boys Football vs 8th grade football (Springfield Middle School (Holland)) (H)

SEPTEMBER

8 THURSDAY

4:45 PM - 5:45 PM - Freshman Girls Volleyball vs Sylvania Northview High School (A)
5:45 PM - 6:45 PM - Junior Varsity Girls Volleyball vs Sylvania Northview High School (A)
6:45 PM - 8:45 PM - Varsity Girls Volleyball vs Sylvania Northview High School (A)
7:00 PM - 9:00 PM - Varsity Boys Soccer vs Liberty Center High School/Middle School (A)

SEPTEMBER

12 MONDAY

4:30 PM - 5:30 PM - Varsity Boys Golf vs Miller City HS/MS (A)
 5:45 PM - 6:45 PM - Junior Varsity Girls Volleyball vs Patrick Henry High School / Middle School (A)
 7:15 PM - 8:15 PM - Varsity Girls Volleyball vs Patrick Henry High School / Middle School (A)

kismet n. -- destiny; fate. Jane believes the way they met was kismet.

SEPTEMBER**13 TUESDAY**

4:30 PM - 6:00 PM - 7/8th Coed Cross Country vs Arbor Hills Junior High School and 1 others (A)
 4:45 PM - 5:45 PM - Freshman Girls Volleyball vs Bowling Green High School - OH (H)
 5:00 PM - 8:00 PM - 7/8th Girls Volleyball vs Bryan High/Middle School (A)
 5:45 PM - 6:45 PM - Junior Varsity Girls Volleyball vs Bowling Green High School - OH (H)
 6:45 PM - 8:45 PM - Varsity Girls Volleyball vs Bowling Green High School - OH (H)

SEPTEMBER**14 WEDNESDAY**

4:30 PM - 6:15 PM - 8th Boys Football vs 8th grade football game (Sylvania Timberstone Junior High School) (H)
 5:00 PM - 6:30 PM - Junior Varsity Girls Soccer vs Sylvania Northview High School - JV (A)
 7:00 PM - 8:45 PM - Varsity Girls Soccer vs Sylvania Northview High School (A)

SEPTEMBER**15 THURSDAY**

4:30 PM - 7:00 PM - 7/8th Girls Volleyball vs junior high volleyball game (Wauseon High/Middle School) (H)
 4:45 PM - 5:45 PM - Freshman Girls Volleyball vs Sylvania Southview High School (H)
 5:00 PM - 7:00 PM - Freshman Boys Football vs Perrysburg High School (A)
 5:45 PM - 6:45 PM - Junior Varsity Girls Volleyball vs Sylvania Southview High School (H)
 6:45 PM - 8:45 PM - Varsity Girls Volleyball vs Sylvania Southview High School (H)

SEPTEMBER

16 FRIDAY

7:00 PM - 9:30 PM - Varsity
Boys Football vs Hall of Fame
(Perrysburg High School) (H)

-cy (state of being) – democracy, obstinacy, accuracy

SEPTEMBER

17 SATURDAY

9:00 AM - 11:00 AM - Varsity Coed Cross Country vs Ottawa-Glandorf High School and 29 others (A)
10:00 AM - 12:00 PM - Junior Varsity Boys Football vs Perrysburg High School (A)
10:00 AM - 1:00 PM - Freshman Girls Volleyball vs 9th VB Tri-Match Napoleon/Defiance (2 Participants) (A)
11:00 AM - 12:00 PM - Junior Varsity Boys Soccer vs Shawnee Local Schools (H)
1:00 PM - 3:00 PM - Varsity Boys Soccer vs Shawnee Local Schools (H)
7:00 PM - 10:00 PM - Varsity Coed Cross Country vs Springfield's "Saturday Night Lights" OC Invitational (18 Participants) (A)

SEPTEMBER

18 SUNDAY

SEPTEMBER

QUOTE OF THE WEEK

"Whether you believe you can do a thing or not, you are right." – Henry Ford

NOTES

19 MONDAY

4:30 PM - 7:00 PM - 7/8th Girls Volleyball vs jr. high volleyball game (Archbold High School) (H)
 4:45 PM - 6:15 PM - 7/8th Boys Cross Country vs 4 county CC River Run (3 Participants) (H)

bifurcate v. - divide into two. Once another employee is hired, the company will bifurcate the bookkeeper's duties.

SEPTEMBER**20 TUESDAY**

4:30 PM - 7:00 PM - Varsity Girls Tennis vs Perrysburg High School (A)
 4:45 PM - 5:45 PM - Freshman Girls Volleyball vs Maumee High School (H)
 5:00 PM - 7:00 PM - Junior Varsity Boys Soccer vs Springfield High School (Holland) - JV (A)
 5:45 PM - 6:45 PM - Junior Varsity Girls Volleyball vs Maumee High School (H)
 6:45 PM - 8:45 PM - Varsity Girls Volleyball vs Maumee High School (H)
 7:00 PM - 9:00 PM - Varsity Boys Soccer vs Springfield High School (Holland) (A)

SEPTEMBER**21 WEDNESDAY**

4:15 PM - 5:45 PM - 7/8th Coed Cross Country vs Jr. High CC try meet (2 Participants) (H)
 4:15 PM - 6:00 PM - 7th Boys Football vs 7th grade football (Anthony Wayne Junior High School) (H)
 4:15 PM - 6:15 PM - 8th Boys Football vs Anthony Wayne Junior High School (A)

SEPTEMBER**22 THURSDAY**

First day of autumn
 4:15 PM - 6:15 PM - 7/8th Girls Volleyball vs Sylvania Timberstone Junior High School (A)
 4:45 PM - 5:45 PM - Freshman Girls Volleyball vs Springfield High School (Holland) (H)
 5:00 PM - 7:00 PM - Freshman Boys Football vs Maumee High School (H)
 5:45 PM - 6:45 PM - Junior Varsity Girls Volleyball vs Springfield High School (Holland) (H)
 6:45 PM - 8:45 PM - Varsity Girls Volleyball vs Springfield High School (Holland) (H)

SEPTEMBER

23 FRIDAY

7:00 PM - 9:30 PM - Varsity Boys Football vs Maumee High School (A)

-rid-, -ris- (to laugh) – derision, risibility, ridiculous

SEPTEMBER

24 SATURDAY

8:30 AM - 9:00 AM - Varsity Coed Cross Country vs Liberty Center High School/Middle School and 43 others (A)
10:00 AM - 12:00 PM - Junior Varsity Boys Football vs Maumee High School (H)

SEPTEMBER

25 SUNDAY

Rosh Hashanah begins at sundown

SEPTEMBER

QUOTE OF THE WEEK

"If you don't like something, change it. If you can't change it, change your attitude. Don't complain." – Maya Angelou

NOTES

26 MONDAY

explicate v. – explain in detail. The students explicated each step of their science project.

SEPTEMBER

27 TUESDAY

9:00 AM - 3:00 PM - Varsity Girls Tennis vs NLL Girls Tennis Championships (7 Participants) (A)
4:45 PM - 5:45 PM - Freshman Girls Volleyball vs Perrysburg High School (A)
5:45 PM - 6:45 PM - Junior Varsity Girls Volleyball vs Perrysburg High School (A)
6:45 PM - 8:45 PM - Varsity Girls Volleyball vs Perrysburg High School (A)
7:00 PM - 8:30 PM - Varsity Boys Soccer vs Bowling Green High School - OH (H)

SEPTEMBER

28 WEDNESDAY

2:00 PM - 5:00 PM - Varsity Girls Tennis vs NLL Girls Tennis Championships (7 Participants) (A)
4:15 PM - 6:00 PM - 7th Boys Football vs 7th grade football (Bowling Green High School - OH) (H)
4:30 PM - 5:30 PM - 7/8th Coed Cross Country vs Perrysburg Junior High School and 1 others (A)
5:00 PM - 7:00 PM - Junior Varsity Girls Soccer vs Bowling Green High School - OH - Girls JV (A)
7:00 PM - 8:30 PM - Varsity Girls Soccer vs Bowling Green High School - OH (A)

SEPTEMBER

29 THURSDAY

4:15 PM - 6:15 PM - 7/8th Girls Volleyball vs Anthony Wayne Junior High School (A)
4:45 PM - 5:45 PM - Freshman Girls Volleyball vs Anthony Wayne High School (H)
5:00 PM - 7:00 PM - Freshman Boys Football vs Springfield High School (Holland) (H)
5:45 PM - 6:45 PM - Junior Varsity Girls Volleyball vs Anthony Wayne High School (H)
6:45 PM - 7:45 PM - Varsity Girls Volleyball vs Anthony Wayne High School (H)

SEPTEMBER

30 FRIDAY

7:00 PM - 9:30 PM - Varsity
Boys Football vs Springfield
Homecoming (Springfield High
School (Holland)) (A)

-via- (way) – deviation, viaduct, trivial

SEPTEMBER

1 SATURDAY

9:00 AM - 2:00 PM - 7/8th Coed Cross Country vs Kalida Wildcat CC
Invitational (31 Participants) (A)
9:00 AM - 2:00 PM - Varsity Coed Cross Country vs Kalida Wildcat CC
Invitational (29 Participants) (A)
10:00 AM - 12:00 PM - Junior Varsity Boys Football vs Springfield High
School (Holland) (H)
10:00 AM - 12:30 PM - 7/8th Coed Cross Country vs Napoleon Jr. High CC
Invite (5 Participants) (H)
11:00 AM - 12:30 PM - Junior Varsity Girls Soccer vs Shawnee Local
Schools (A)
1:00 PM - 3:00 PM - Varsity Girls Soccer vs Shawnee Local Schools (A)
2:00 PM - 4:00 PM - Varsity Boys Soccer vs Lake High School-Millbury (H)

OCTOBER

2 SUNDAY

OCTOBER

**QUOTE OF
THE WEEK**

“Think it more satisfactory to live richly than die rich.” – Sir Thomas Browne

NOTES

3 MONDAY

4:30 PM - 6:45 PM - 7/8th Girls Volleyball vs Defiance High School (A)

OCTOBER

largess n. – generosity. My grandpa showed great largess when he gave me his restored hot rod.

4 TUESDAY

Yom Kippur begins at sundown
4:45 PM - 5:45 PM - Freshman Girls Volleyball vs Sylvania Northview High School (H)
5:00 PM - 6:30 PM - Junior Varsity Boys Soccer vs Perrysburg High School - JV (A)
5:45 PM - 6:45 PM - Junior Varsity Girls Volleyball vs Sylvania Northview High School (H)
6:45 PM - 8:45 PM - Varsity Boys Soccer vs Perrysburg High School (A)
6:45 PM - 8:45 PM - Varsity Girls Volleyball vs Sylvania Northview High School (H)

OCTOBER

5 WEDNESDAY

4:30 PM - 6:15 PM - 8th Boys Football vs 8th grade football (Arbor Hills Junior High School) (H)

OCTOBER

6 THURSDAY

4:45 PM - 5:45 PM - Freshman Girls Volleyball vs Bowling Green High School - OH (A)
5:45 PM - 6:45 PM - Junior Varsity Girls Volleyball vs Bowling Green High School - OH (A)
6:45 PM - 8:45 PM - Freshman Girls Volleyball vs TBA (A)
7:00 PM - 9:00 PM - Varsity Girls Volleyball vs Bowling Green High School - OH (A)

OCTOBER

10 MONDAY

Columbus Day

OCTOBER

*ameliorate v. -- improve. Foreign aid is badly needed to ameliorate the effects of the drought.***11 TUESDAY**

4:45 PM - 5:45 PM - Freshman Girls Volleyball vs Sylvania Southview High School (A)
 5:45 PM - 6:45 PM - Junior Varsity Girls Volleyball vs Sylvania Southview High School (A)
 6:45 PM - 8:45 PM - Varsity Girls Volleyball vs Sylvania Southview High School (A)

OCTOBER

12 WEDNESDAY

4:15 PM - 6:00 PM - 7th Boys Football vs 7th grade football (Perrysburg Junior High School) (H)
 4:30 PM - 6:00 PM - 8th Boys Football vs Perrysburg Junior High School (A)
 5:00 PM - 6:15 PM - Junior Varsity Girls Soccer vs Maumee High School (A)
 7:00 PM - 8:30 PM - Varsity Girls Soccer vs Maumee High School (A)

OCTOBER

13 THURSDAY

4:45 PM - 5:45 PM - Freshman Girls Volleyball vs Maumee High School (A)
 5:00 PM - 7:00 PM - Freshman Boys Football vs Sylvania Southview High School (A)
 5:45 PM - 6:45 PM - Junior Varsity Girls Volleyball vs Maumee High School (A)
 6:45 PM - 7:45 PM - Varsity Girls Volleyball vs Maumee High School (A)

OCTOBER

14 FRIDAY

7:00 PM - 9:30 PM - Varsity Boys Football vs Senior Night (Sylvania Southview High School) (H)

-diurn- (day) – diary, diurnal, journey

OCTOBER

15 SATURDAY10:00 AM - 11:00 AM - Freshman Girls Volleyball vs Defiance High School (A)
10:00 AM - 12:00 PM - Junior Varsity Boys Football vs Sylvania Southview High School (A)
11:00 AM - 12:00 PM - Junior Varsity Girls Volleyball vs Defiance High School (A)
12:00 PM - 1:30 PM - Varsity Girls Volleyball vs Defiance High School (A)
1:00 PM - 2:45 PM - Varsity Boys Soccer vs Bryan High/Middle School (A)

OCTOBER

16 SUNDAY

OCTOBER

QUOTE OF THE WEEK

"Be yourself. Who else is better qualified?" – Frank J. GIBLIN II

NOTES

17 MONDAY

acumen n. – keenness of intellect. She has considerable financial acumen.

OCTOBER

18 TUESDAY

OCTOBER

19 WEDNESDAY

4:15 PM - 6:00 PM - 8th Boys Football vs 8th grade football game (Gateway Middle School) (H)

OCTOBER

20 THURSDAY

OCTOBER

21 FRIDAY

7:00 PM - 9:30 PM - Varsity Boys
Football vs Bowling Green High
School - OH (A)

dis-, dif- (not) – discord, differ, distrust

OCTOBER

22 SATURDAY

OCTOBER

23 SUNDAY

OCTOBER

**QUOTE OF
THE WEEK**

“I am not afraid of storms, for I am learning how to sail my ship.” – Louisa May Alcott

NOTES

24 MONDAY

apathy n. – lack of interest. Student apathy forced the club to dissolve.

OCTOBER

25 TUESDAY

OCTOBER

26 WEDNESDAY

OCTOBER

27 THURSDAY

OCTOBER

31 MONDAY*Halloween*

OCTOBER

demagogue n. – leader who appeals to popular prejudices to gain power. The demagogue blamed immigrants for the lack of jobs.

1 TUESDAY

NOVEMBER

2 WEDNESDAY

NOVEMBER

3 THURSDAY

NOVEMBER

4 FRIDAY	
<small>-domin- (to rule) – dominate, domain, dominant</small>	NOVEMBER
5 SATURDAY	
	NOVEMBER
6 SUNDAY	<i>Standard time begins</i>
	NOVEMBER

QUOTE OF THE WEEK "Learn to listen. Opportunity could be knocking at your door very softly." – Frank Tyger

NOTES

7 MONDAY

gourmand n. – lover of fine food. Jeff became a real gourmand after years of peanut butter sandwiches.

NOVEMBER

8 TUESDAY

Election Day

NOVEMBER

9 WEDNESDAY

NOVEMBER

10 THURSDAY

NOVEMBER

14 MONDAY

assuage v. – make less severe. *The government has tried to assuage the public's fears.*

NOVEMBER

15 TUESDAY

NOVEMBER

16 WEDNESDAY

NOVEMBER

17 THURSDAY

NOVEMBER

18 FRIDAY

6:00 PM - 7:15 PM - Junior Varsity
Girls Basketball vs Patrick Henry
High School / Middle School (H)
7:15 PM - 9:15 PM - Varsity Girls
Basketball vs Patrick Henry High
School / Middle School (H)

-ess (female) – goddess, lioness, actress, priestess

NOVEMBER

19 SATURDAY

4:00 PM - 5:00 PM - Junior Varsity
Girls Basketball vs Defiance High
School (H)
6:00 PM - 8:00 PM - Varsity Girls
Basketball vs Defiance High
School - squad 1 (H)

NOVEMBER

20 SUNDAY

NOVEMBER

**QUOTE OF
THE WEEK**

"Talk about a dream; try to make it real." – Bruce Springsteen

NOTES

21 MONDAY

foible n. – minor weakness. While the employee’s résumé is outstanding, his late arrival is a foible.

NOVEMBER

22 TUESDAY

4:45 PM - 5:45 PM - Freshman Girls Basketball vs Perrysburg High School (H)
6:00 PM - 7:15 PM - Junior Varsity Girls Basketball vs Perrysburg High School (H)
7:30 PM - 9:30 PM - Varsity Girls Basketball vs Perrysburg High School (H)

NOVEMBER

23 WEDNESDAY

NOVEMBER

24 THURSDAY

Thanksgiving

NOVEMBER

25 FRIDAY

6:00 PM - 7:15 PM - Junior Varsity
Boys Basketball vs Patrick Henry
High School / Middle School (H)
7:15 PM - 9:15 PM - Varsity Boys
Basketball vs Patrick Henry High
School / Middle School (H)

ego- (*l. self*) – egoist, egotist, egocentric

NOVEMBER

26 SATURDAY

4:30 PM - 5:30 PM - Freshman Boys
Basketball vs Defiance High School (A)
6:00 PM - 7:15 PM - Junior Varsity Boys
Basketball vs Defiance High School (A)
7:30 PM - 9:00 PM - Varsity Boys
Basketball vs Defiance High School (A)

NOVEMBER

27 SUNDAY

NOVEMBER

**QUOTE OF
THE WEEK**

“The lips know only shallow tunes. The heart is where great symphonies are born.” – Calvin Miller

NOTES

28 MONDAY4:30 PM - 7:00 PM - 7/8th Boys
Basketball vs TBA (H)

NOVEMBER

*retrogress v. – move backward. The project's failure forced the team to retrogress.***29 TUESDAY**4:30 PM - 5:30 PM - 7/8th Boys
Basketball vs Liberty Center High
School/Middle School (A)4:30 PM - 7:00 PM - 7/8th Girls
Basketball vs JH girls basketball
game (Liberty Center High School/
Middle School) (H)4:45 PM - 5:45 PM - Freshman Girls
Basketball vs Sylvania Northview
High School (A)6:00 PM - 7:15 PM - Junior Varsity
Girls Basketball vs Sylvania
Northview High School (A)7:30 PM - 9:30 PM - Varsity Girls
Basketball vs Sylvania Northview
High School (A)

NOVEMBER

30 WEDNESDAY

NOVEMBER

1 THURSDAY4:45 PM - 5:45 PM - Freshman Girls
Basketball vs Springfield High
School (Holland) (H)6:00 PM - 7:15 PM - Junior Varsity
Girls Basketball vs Springfield High
School (Holland) (H)7:30 PM - 9:30 PM - Varsity Girls
Basketball vs Springfield High
School (Holland) (H)

DECEMBER

5 MONDAY

4:30 PM - 6:30 PM - 7/8th Girls Basketball vs Archbold High School (A)
 4:30 PM - 7:00 PM - 7/8th Boys Basketball vs Boys JH basketball game (Archbold High School) (H)

DECEMBER

clamor n. – noise. It was difficult to hear over the clamor in the train station.

6 TUESDAY

4:45 PM - 5:45 PM - Freshman Girls Basketball vs Maumee High School (A)
 6:00 PM - 7:15 PM - Junior Varsity Girls Basketball vs Maumee High School (A)
 7:30 PM - 9:30 PM - Varsity Girls Basketball vs Maumee High School (A)

DECEMBER

7 WEDNESDAY

DECEMBER

8 THURSDAY

4:45 PM - 5:45 PM - Freshman Girls Basketball vs Sylvania Southview High School (A)
 6:00 PM - 7:15 PM - Junior Varsity Girls Basketball vs Sylvania Southview High School (A)
 6:00 PM - 8:00 PM - Varsity Boys Wrestling vs Anthony Wayne High School (H)
 7:30 PM - 9:30 PM - Varsity Girls Basketball vs Sylvania Southview High School (A)

DECEMBER

12 MONDAY

coterie n. – often exclusive group of persons with a similar purpose. The coterie of authors liked to discuss their favorite books.

DECEMBER

13 TUESDAY

4:30 PM - 7:15 PM - 7/8th Boys Basketball vs jr. high boys basketball game (Defiance Middle School) (H)
 4:30 PM - 7:15 PM - 7/8th Girls Basketball vs Defiance High School (A)
 6:00 PM - 7:00 PM - Junior Varsity Girls Basketball vs Bryan High/Middle School (A)
 7:30 PM - 9:00 PM - Varsity Girls Basketball vs Bryan High/Middle School (A)

DECEMBER

14 WEDNESDAY

4:30 PM - 6:30 PM - 7/8th Boys Wrestling vs Anthony Wayne Junior High School and 1 others (A)

DECEMBER

15 THURSDAY

4:30 PM - 7:00 PM - 7/8th Boys Basketball vs Wauseon High/Middle School (A)
 4:30 PM - 7:00 PM - 7/8th Girls Basketball vs jr. high girls basketball game (Wauseon High/Middle School) (H)
 4:45 PM - 5:45 PM - Freshman Girls Basketball vs Bowling Green High School - OH (A)
 6:00 PM - 7:15 PM - Junior Varsity Girls Basketball vs Bowling Green High School - OH (A)
 7:30 PM - 9:30 PM - Varsity Girls Basketball vs Bowling Green High School - OH (A)

DECEMBER

16 FRIDAY

Varsity Girls Wrestling vs Findlay Invitational Girls HS Tournament (20 Participants) (A)
2:00 PM - 7:00 PM - Varsity Boys Wrestling vs Archbold Frickers Duals at Defiance College (19 Participants) (A)
4:45 PM - 5:45 PM - Freshman Boys Basketball vs Sylvania Northview High School - Freshmen Black (H)
6:00 PM - 7:15 PM - Junior Varsity Boys Basketball vs Sylvania Northview High School (H)
7:30 PM - 9:30 PM - Varsity Boys Basketball vs Sylvania Northview High School (H)

-luc- (light) – elucidate, lucid, translucent

DECEMBER

17 SATURDAY

Varsity Girls Wrestling vs Findlay Invitational Girls HS Tournament (20 Participants) (A)
9:00 AM - 3:00 PM - 78th Boys Wrestling (A)
9:00 AM - 3:00 PM - Junior Varsity Boys Wrestling vs Witt Classic JV Tournament (18 Participants) (A)
10:00 AM - 12:30 PM - 78th Girls Basketball vs NJH girls basketball games (Patrick Henry High School / Middle School) (H)
10:00 AM - 3:00 PM - Varsity Boys Wrestling vs Archbold Frickers Duals at Defiance College (19 Participants) (A)
12:30 PM - 3:00 PM - 78th Boys Basketball vs MJH Boys Basketball (Patrick Henry High School / Middle School) (H)
6:00 PM - 6:30 PM - Junior Varsity Boys Basketball vs Bryan High/Middle School (H)
7:15 PM - 9:15 PM - Varsity Boys Basketball vs Bryan High/Middle School (H)

DECEMBER

18 SUNDAY

Hanukkah begins at sundown

DECEMBER

QUOTE OF THE WEEK

“If you hear a voice within you saying ‘You are not a painter,’ then by all means paint, and that voice will be silenced.” – Vincent van Gogh

NOTES

Blank lined area for notes.

19 MONDAY

DECEMBER

*augury n. -- omen; prediction. Dan hoped his early victory was an augury of a winning season.***20 TUESDAY**

4:30 PM - 6:30 PM - 7/8th Boys Basketball vs JH Boys vs NJHS (Holgate High School) (A)
 4:30 PM - 7:00 PM - 7/8th Girls Basketball vs NJH girls basketball game (Holgate High School) (H)
 5:00 PM - 6:00 PM - 7/8th Boys Wrestling vs Defiance High School (A)
 5:30 PM - 8:00 PM - Varsity Boys Swimming vs Wauseon High/Middle School (A)
 5:30 PM - 8:00 PM - Varsity Girls Swimming vs Wauseon High/Middle School (A)
 6:00 PM - 7:30 PM - Varsity Boys Wrestling vs Defiance High School (A)

DECEMBER

21 WEDNESDAY*First day of winter*

DECEMBER

22 THURSDAY

10:00 AM - 12:00 PM - Junior Varsity Boys Wrestling vs AW JV Wrestling Invitational (20 Participants) (A)
 4:15 PM - 6:15 PM - 7/8th Girls Basketball vs Tinora High/Junior High School (A)
 4:15 PM - 6:45 PM - 7/8th Boys Basketball vs NJH boys basketball (Tinora High/Junior High School) (H)
 6:00 PM - 6:30 PM - Junior Varsity Girls Basketball vs Ottawa-Glandorf High School (A)
 7:30 PM - 8:00 PM - Varsity Girls Basketball vs Ottawa-Glandorf High School (A)

DECEMBER

26 MONDAY*Kwanzaa begins***DECEMBER***penury n. – poverty. The decrepit buildings gave the area a mark of penury.***27 TUESDAY**

6:00 PM - 7:45 PM - Varsity Girls Basketball vs TBA (H)
 6:00 PM - 10:00 PM - Varsity Girls Basketball (H)
 8:00 PM - 9:45 PM - Varsity Girls Basketball vs TBA (H)

DECEMBER**28 WEDNESDAY**

10:00 AM - 4:00 PM - Junior Varsity Boys Wrestling (A)
 6:00 PM - 7:45 PM - Varsity Boys Basketball vs TBA (H)
 6:00 PM - 10:00 PM - Varsity Boys Basketball (H)
 8:00 PM - 9:45 PM - Varsity Boys Basketball vs TBA (H)

DECEMBER**29 THURSDAY**

12:00 PM - 8:00 PM - Varsity Boys Wrestling vs DEFIANCE BORDER WAR INVITE (51 Participants) (A)
 6:00 PM - 7:45 PM - Varsity Girls Basketball vs TBA (H)
 8:00 PM - 9:45 PM - Varsity Girls Basketball vs TBA (H)

DECEMBER

30 FRIDAY

9:30 AM - 6:30 PM - Varsity Boys Wrestling vs DEFIANCE BORDER WAR INVITE (52 Participants) (A)
6:00 PM - 7:45 PM - Varsity Boys Basketball vs TBA (H)
8:00 PM - 9:45 PM - Varsity Boys Basketball vs TBA (H)

-fid-, -fide-, -feder- (faith, trust) – confidante, fidelity, confident, infidel, federal, confederacy

DECEMBER

31 SATURDAY

DECEMBER

1 SUNDAY

New Year's Day

JANUARY

QUOTE OF THE WEEK

"The point is not to pay back kindness but to pass it on." – Julia Alvarez

NOTES

2 MONDAY

temerity n. – reckless boldness. She had the temerity to call me a liar.

JANUARY

3 TUESDAY

JANUARY

4 WEDNESDAY

JANUARY

5 THURSDAY

5:00 PM - 6:00 PM - Freshman Girls Basketball vs Anthony Wayne High School (H)

5:00 PM - 7:30 PM - 7/8th Boys Basketball vs Boys JH basketball (Bryan High/Middle School) (H)

5:00 PM - 8:00 PM - 7/8th Girls Basketball vs Bryan High/Middle School (A)

6:00 PM - 7:00 PM - Freshman Boys Basketball vs Anthony Wayne High School (H)

7:00 PM - 8:15 PM - Junior Varsity Boys Basketball vs Anthony Wayne High School (H)

JANUARY

9 MONDAY

umbrage n. – *resentment at a perceived slight or insult. He took umbrage at not landing the lead role.*

JANUARY**10 TUESDAY**

4:15 PM - 6:45 PM - 7/8th Girls Basketball vs girls JH basketball game (Bowling Green High School - OH) (H)
 4:45 PM - 5:45 PM - Freshman Boys Basketball vs Sylvania Southview High School (A)
 6:00 PM - 7:15 PM - Junior Varsity Boys Basketball vs Sylvania Southview High School (A)
 7:30 PM - 9:30 PM - Varsity Boys Basketball vs Sylvania Southview High School (A)

JANUARY**11 WEDNESDAY**

JANUARY**12 THURSDAY**

5:00 PM - 6:00 PM - Freshman Girls Basketball vs Perrysburg High School (A)
 6:00 PM - 7:00 PM - Freshman Boys Basketball vs Perrysburg High School (A)
 7:00 PM - 8:15 PM - Junior Varsity Boys Basketball vs Perrysburg High School (A)

JANUARY

13 FRIDAY

3:00 PM - 9:00 AM - Varsity Boys Wrestling (H)
 3:00 PM - 3:30 PM - Varsity Boys Wrestling vs TBA (H)
 4:45 PM - 6:00 PM - Junior Varsity Girls Basketball vs Perrysburg High School (A)
 6:00 PM - 8:00 PM - Varsity Girls Basketball vs Perrysburg High School (A)
 8:00 PM - 10:00 PM - Varsity Boys Basketball vs Perrysburg High School (A)

-ine (nature of) – masculine, genuine, medicine, opaline, Benedictine

JANUARY

14 SATURDAY

9:00 AM - 9:30 AM - Varsity Boys Wrestling vs TBA (H)

JANUARY

15 SUNDAY

JANUARY

QUOTE OF THE WEEK

"My life is my message." – Mahatma Gandhi

NOTES

16 MONDAY*Martin Luther King Jr. Day**zephyr n. – soft breeze. The zephyr helped cool the farm laborers.***JANUARY****17 TUESDAY**

4:30 PM - 6:30 PM - 7/8th Boys Basketball vs Arbor Hills Junior High School (A)
 4:30 PM - 7:00 PM - 7/8th Girls Basketball vs NJH Girls bk game (Arbor Hills Junior High School) (H)
 4:45 PM - 5:45 PM - Freshman Girls Basketball vs Sylvania Northview High School (H)
 6:00 PM - 7:15 PM - Junior Varsity Girls Basketball vs Sylvania Northview High School (H)
 7:30 PM - 9:30 PM - Varsity Girls Basketball vs Sylvania Northview High School (H)

JANUARY**18 WEDNESDAY**

4:00 PM - 6:00 PM - 7/8th Boys Wrestling vs Perrysburg Junior High School - and 1 others (A)

JANUARY**19 THURSDAY**

4:15 PM - 6:45 PM - 7/8th Girls Basketball vs NJH girls BK game (Gateway Middle School) (H)
 5:00 PM - 6:00 PM - Freshman Girls Basketball vs Springfield High School (Holland) (A)
 6:00 PM - 7:00 PM - Freshman Boys Basketball vs Springfield High School (Holland) (A)
 7:30 PM - 8:45 PM - Junior Varsity Boys Basketball vs Springfield High School (Holland) (A)

JANUARY

20 FRIDAY

4:45 PM - 6:00 PM - Junior Varsity
Girls Basketball vs Springfield High
School (Holland) (A)
6:00 PM - 8:00 PM - Varsity Girls
Basketball vs Springfield High
School (Holland) (A)
8:00 PM - 10:00 PM - Varsity Boys
Basketball vs Springfield High
School (Holland) (A)

-plac-, -pac- (please) – placid, placebo, placate, complacent, pacify

JANUARY

21 SATURDAY

10:00 AM - 3:00 PM - 7/8th Boys Wrestling
vs Wauseon Junior High Wrestling
Invitational (21 Participants) (A)
10:00 AM - 3:00 PM - Varsity Girls
Wrestling vs Ridgedale Girls Wrestling
Invitational (36 Participants) (A)

JANUARY

22 SUNDAY

Lunar New Year

JANUARY

**QUOTE OF
THE WEEK**

“There is nothing like a dream to create the future.” – Victor Hugo

NOTES

23 MONDAY

knell n. – solemn sound of a bell. The funeral knell made the stormy day even grimmer.

JANUARY**24 TUESDAY**

4:15 PM - 6:15 PM - 7/8th Boys Basketball vs Perrysburg Junior High School (A)

4:15 PM - 6:45 PM - 7/8th Girls Basketball vs NJH Girls BK game (Perrysburg Junior High School) (H)

4:45 PM - 5:45 PM - Freshman Girls Basketball vs Sylvania Southview High School (H)

6:00 PM - 7:15 PM - Junior Varsity Girls Basketball vs Sylvania Southview High School (H)

7:30 PM - 9:30 PM - Varsity Girls Basketball vs Sylvania Southview High School (H)

JANUARY**25 WEDNESDAY**

6:00 PM - 8:00 PM - Varsity Boys Wrestling vs Liberty-Benton High School (H)

JANUARY**26 THURSDAY**

4:30 PM - 6:00 PM - 7/8th Boys Basketball vs McCord Junior High School (A)

5:00 PM - 6:00 PM - Freshman Girls Basketball vs Maumee High School (H)

6:00 PM - 7:00 PM - Freshman Boys Basketball vs Maumee High School (H)

7:30 PM - 8:45 PM - Junior Varsity Boys Basketball vs Maumee High School (H)

JANUARY

27 FRIDAY

4:45 PM - 6:00 PM - Junior Varsity
Girls Basketball vs Maumee High
School (H)
6:00 PM - 8:00 PM - Varsity Girls
Basketball vs Maumee High
School (H)
8:00 PM - 10:00 PM - Varsity Boys
Basketball vs Maumee High
School (H)

ante- (before) – antecedent, antediluvian, antenuptial

JANUARY

28 SATURDAY

JANUARY

29 SUNDAY

JANUARY

**QUOTE OF
THE WEEK**

"I have discovered in life that there are ways of getting almost anywhere
you want to go, if you really want to go." – Langston Hughes

NOTES

30 MONDAY

4:15 PM - 6:45 PM - 7/8th Boys Basketball vs NJH Boys BK game (Anthony Wayne Junior High School) (H)
 4:15 PM - 6:45 PM - 7/8th Girls Basketball vs Anthony Wayne Junior High School (A)

JANUARY

mollify v. – soothe; soften in feeling. He tried to mollify the wailing infant with a walk around the block.

31 TUESDAY

4:30 PM - 7:00 PM - 7/8th Girls Basketball vs NJH Girls BK game (Springfield Middle School (Holland)) (H)
 4:45 PM - 5:45 PM - Freshman Boys Basketball vs Bowling Green High School - OH (A)
 6:00 PM - 7:15 PM - Junior Varsity Boys Basketball vs Bowling Green High School - OH (A)
 7:30 PM - 9:30 PM - Varsity Boys Basketball vs Bowling Green High School - OH (A)

JANUARY

1 WEDNESDAY

FEBRUARY

2 THURSDAY

Groundhog Day
 4:30 PM - 7:00 PM - 7/8th Boys Basketball vs NJH Boys bk game (Sylvania Timberstone Junior High School) (H)
 4:45 PM - 5:45 PM - Freshman Girls Basketball vs Bowling Green High School - OH (H)
 6:00 PM - 7:15 PM - Junior Varsity Girls Basketball vs Bowling Green High School - OH (H)
 7:30 PM - 9:30 PM - Varsity Girls Basketball vs Bowling Green High School - OH (H)

FEBRUARY

6 MONDAY

maladroit adj. – awkward; tactless; inept. His *maladroit* response to criticism upset would-be voters.

FEBRUARY

7 TUESDAY

4:45 PM - 5:45 PM - Freshman Boys Basketball vs Anthony Wayne High School (A)
 6:00 PM - 7:15 PM - Junior Varsity Boys Basketball vs Anthony Wayne High School (A)
 7:30 PM - 9:30 PM - Varsity Boys Basketball vs Anthony Wayne High School (A)

FEBRUARY

8 WEDNESDAY

7th Boys Basketball (A)

FEBRUARY

9 THURSDAY

4:30 PM - 5:30 PM - Freshman Girls Basketball vs Anthony Wayne High School (A)
 6:00 PM - 7:15 PM - Junior Varsity Girls Basketball vs Anthony Wayne High School (A)
 6:00 PM - 8:00 PM - Varsity Boys Wrestling vs Pike-Delta-York High School (H)
 7:30 PM - 9:30 PM - Varsity Girls Basketball vs Anthony Wayne High School (A)

FEBRUARY

10 FRIDAY

4:45 PM - 5:45 PM - Freshman Boys Basketball vs Sylvania Southview High School (H)
 6:00 PM - 7:15 PM - Junior Varsity Boys Basketball vs Sylvania Southview High School (H)
 7:30 PM - 9:30 PM - Varsity Boys Basketball vs Sylvania Southview High School (H)

aqua- (*water*) – *aqueduct, aquatic, aquarium*

FEBRUARY

11 SATURDAY

6:00 PM - 7:00 PM - Junior Varsity Boys Basketball vs Archbold High School (A)
 7:30 PM - 9:30 PM - Varsity Boys Basketball vs Archbold High School (A)

FEBRUARY

12 SUNDAY

Lincoln's Birthday

FEBRUARY

QUOTE OF THE WEEK

"Everyone can be great because everyone can serve." – Martin Luther King Jr.

NOTES

13 MONDAY

mutable adj. – changeable. A folding screen creates a mutable partition in a large room.

FEBRUARY

14 TUESDAY

Valentine's Day
 4:45 PM - 5:45 PM - Freshman Boys Basketball vs Perrysburg High School (H)
 6:00 PM - 7:15 PM - Junior Varsity Boys Basketball vs Perrysburg High School (H)
 7:30 PM - 9:30 PM - Varsity Boys Basketball vs Perrysburg High School (H)

FEBRUARY

15 WEDNESDAY

FEBRUARY

16 THURSDAY

FEBRUARY

17 FRIDAY

4:45 PM - 5:45 PM - Freshman Boys Basketball vs Springfield High School (Holland) (H)
 6:00 PM - 7:15 PM - Junior Varsity Boys Basketball vs Springfield High School (Holland) (H)
 7:30 PM - 9:30 PM - Varsity Boys Basketball vs Springfield High School (Holland) (H)

-astr- (*star*) – astronomy, astrology, astronaut, astrophysics, astrolabe

FEBRUARY**18 SATURDAY**

10:00 AM - 5:00 PM - Varsity Boys Wrestling vs Sylvania Northview High School - Varsity A and 6 others (A)

FEBRUARY**19 SUNDAY****FEBRUARY****QUOTE OF THE WEEK**

"I change myself, I change the world." – Gloria Anzaldúa

NOTES

20 MONDAY

Presidents' Day

adroit adj. – clever; skillful. *The dancer was adroit enough to succeed in both tap and ballet.*

FEBRUARY

21 TUESDAY

FEBRUARY

22 WEDNESDAY

*Ash Wednesday
Washington's Birthday*

FEBRUARY

23 THURSDAY

FEBRUARY

27 MONDAY

bovine adj. – cow-like; dull. *The travelers wore bovine expressions while waiting in the airport.*

FEBRUARY

28 TUESDAY

FEBRUARY

1 WEDNESDAY

MARCH

2 THURSDAY

MARCH

6 MONDAY

ribald adj. – crude; profane. *His ribald stories offended the wedding guests.*

MARCH

7 TUESDAY

MARCH

8 WEDNESDAY

MARCH

9 THURSDAY

MARCH

13 MONDAY

anomalous adj. – deviating from the normal. Her anomalous teaching methods inspired students who had tired of lectures.

MARCH

14 TUESDAY

MARCH

15 WEDNESDAY

MARCH

16 THURSDAY

MARCH

20 MONDAY

First day of spring

irascible adj. – easily angered. Her frequent outbursts show she’s becoming more irascible with time.

MARCH

21 TUESDAY

MARCH

22 WEDNESDAY

Ramadan begins at sundown

MARCH

23 THURSDAY

MARCH

27 MONDAY

effusive adj. – *excessively enthusiastic; gushy. Their effusive welcome was flattering but uncomfortable.*

MARCH

28 TUESDAY

5:00 PM - 7:00 PM - Varsity Boys
Baseball vs Bryan High/Middle
School (A)
5:00 PM - 7:00 PM - Varsity Girls
Softball vs Defiance High School
(A)

MARCH

29 WEDNESDAY

MARCH

30 THURSDAY

5:00 PM - 7:00 PM - Junior Varsity
Boys Baseball vs Wauseon High/
Middle School (A)

MARCH

3 MONDAY

ebullient adj. – exhilarated; enthusiastic. The contestant was in an ebullient mood after winning the grand prize.

APRIL

4 TUESDAY

5:00 PM - 7:00 PM - Junior Varsity Girls Softball vs Bryan High/Middle School (A)
5:00 PM - 7:00 PM - Varsity Boys Baseball vs Archbold High School (A)

APRIL

5 WEDNESDAY

Passover begins at sundown

APRIL

6 THURSDAY

APRIL

10 MONDAY

spurious adj. – false; not genuine. They made spurious claims of personal injury.

APRIL

11 TUESDAY

APRIL

12 WEDNESDAY

APRIL

13 THURSDAY

APRIL

17 MONDAY

fortuitous adj. – happening by chance. The collapse of its competitors brought fortuitous gains to the company.

APRIL

18 TUESDAY

APRIL

19 WEDNESDAY

APRIL

20 THURSDAY

5:30 PM - 7:30 PM - Varsity Girls Softball vs Celina High School (A)

APRIL

24 MONDAY

beatific adj. – having a blissful appearance. The woman's beatific smile made her look years younger.

APRIL

25 TUESDAY

APRIL

26 WEDNESDAY

APRIL

27 THURSDAY

APRIL

28 FRIDAY

4:30 PM - 5:00 PM - Varsity Coed
Track - Outdoor vs Otsego
Tim Downey Invitational (7
Participants) (A)

APRIL

cata- (down, break) – catastrophe, cataract, catapult

29 SATURDAY

APRIL

30 SUNDAY

APRIL

**QUOTE OF
THE WEEK**

“Life is a promise; fulfill it.” – Mother Teresa

NOTES

1 MONDAY

halcyon adj. – idyllic; calm. *Amidst the turmoil, she dreamily recalled her halcyon days on the beach.*

MAY

2 TUESDAY

MAY

3 WEDNESDAY

MAY

4 THURSDAY

MAY

8 MONDAY

facetious adj. – inappropriately flippant. He showed his disapproval with facetious remarks.

MAY

9 TUESDAY

MAY

10 WEDNESDAY

MAY

11 THURSDAY

MAY

15 MONDAY

feckless adj. – ineffective; worthless. *His girlfriend's father felt he was feckless, even though he tried to find a job.*

MAY

16 TUESDAY

MAY

17 WEDNESDAY

MAY

18 THURSDAY

MAY

22 MONDAY

choleric adj. – irritable; short-tempered. The children's exuberant play rankled their choleric neighbor.

MAY

23 TUESDAY

MAY

24 WEDNESDAY

MAY

25 THURSDAY

MAY

29 MONDAY

Memorial Day

irreverent adj. – lacking respect. The television program takes an irreverent look at doctors.

MAY

30 TUESDAY

MAY

31 WEDNESDAY

MAY

1 THURSDAY

JUNE

5 MONDAY

impious adj. – lacking reverence or respect. His callous attitude toward others reflects his impious character.

JUNE

6 TUESDAY

JUNE

7 WEDNESDAY

JUNE

8 THURSDAY

JUNE

12 MONDAY

lugubrious adj. – melancholy; sorrowful. His lugubrious attitude showed he was upset.

JUNE

13 TUESDAY

JUNE

14 WEDNESDAY

Flag Day

JUNE

15 THURSDAY

JUNE

19 MONDAY*Juneteenth*

ignoble adj. – of low character. *Because Beth knew of the man's ignoble reputation, she didn't hire him as a security guard.*

JUNE

20 TUESDAY

JUNE

21 WEDNESDAY*First day of summer*

JUNE

22 THURSDAY

JUNE

JUNE 2023

★ GOALS

MONDAY	TUESDAY	WEDNESDAY	THURSDAY
29	30	31	1
5	6	7	8
12	13	14 <i>Flag Day</i>	15
19 <i>Juneteenth</i>	20	21 <i>First day of summer</i>	22
26	27	28 <i>Eid al-Adha begins at sundown</i>	29

REMINDERS

FRIDAY	SATURDAY	SUNDAY	NOTES
2	3	4	<hr/> <hr/> <hr/> <hr/> <hr/>
9	10	11	<hr/> <hr/> <hr/> <hr/> <hr/>
16	17	<i>Father's Day</i>	<hr/> <hr/> <hr/> <hr/> <hr/>
23	24	25	<hr/> <hr/> <hr/> <hr/> <hr/>
30	1	2	<hr/> <hr/> <hr/> <hr/> <hr/>

JULY 2023

★ GOALS

MONDAY	TUESDAY	WEDNESDAY	THURSDAY
26	27	28	29
3	4 <i>Independence Day</i>	5	6
10	11	12	13
17	18 <i>Muharram begins at sundown</i>	19	20
24	25	26	27
31			

REMINDERS

FRIDAY	SATURDAY	SUNDAY	NOTES
30	1	2	<hr/> <hr/> <hr/> <hr/> <hr/>
7	8	9	<hr/> <hr/> <hr/> <hr/> <hr/>
14	15	16	<hr/> <hr/> <hr/> <hr/> <hr/>
21	22	23	<hr/> <hr/> <hr/> <hr/> <hr/>
28	29	30	<hr/> <hr/> <hr/> <hr/> <hr/>

AUGUST 2023

★ GOALS

MONDAY	TUESDAY	WEDNESDAY	THURSDAY
31	1	2	3
7	8	9	10
14	15	16	17
21	22	23	24
28	29	30	31

REMINDERS

FRIDAY	SATURDAY	SUNDAY	NOTES
4	5	6	<hr/> <hr/> <hr/> <hr/> <hr/>
11	12	13	<hr/> <hr/> <hr/> <hr/> <hr/>
18	19	20	<hr/> <hr/> <hr/> <hr/> <hr/>
25	26	27	<hr/> <hr/> <hr/> <hr/> <hr/>
1	2	3	<hr/> <hr/> <hr/> <hr/> <hr/>

LANGUAGE ARTS *sentence structure & spelling rules*



SENTENCE STRUCTURE

A **complete sentence** must express a complete thought and must have a subject and a verb.

→ *Example:* He lost the game.

A **sentence fragment** results from a *missing* subject, verb or complete thought.

→ *Example:* Because he was lost.

THERE ARE FOUR TYPES OF SENTENCES: SIMPLE, COMPOUND, COMPLEX, OR COMPOUND-COMPLEX

1

A **simple sentence** consists of one main clause. It expresses one main thought and has one subject and one verb. A simple sentence may contain a compound subject, compound verb, or both.

→ *Examples:* We enjoyed the concert.

Amy and Scott were married yesterday. (compound subject: Amy and Scott)

Ben is leaving work and going home. (compound verb: leaving and going)

2

A **compound sentence** contains two or more main clauses (in italics) connected by a conjunction, a semicolon or a comma with a conjunction.

→ *Examples:* *Collecting fossils is fun, but I think identifying fossils is difficult.* (conjunction)

Andy's suit looks new; it just got back from the cleaners. (semicolon)

Erin came home for Easter, and Courtney went to Florida. (comma/conjunction)

3

A **complex sentence** has one main clause (in italics) and one or more subordinate clauses (underlined).

→ *Examples:* *Dad says that good grades are the result of diligent studying.* (main clause, one independent clause)

Diligent studying is difficult, because I have to work several hours before I can start studying. (main clause, two dependent clauses)

4

A **compound-complex sentence** has two or more main clauses (in italics) and one or more subordinate clauses (underlined).

→ *Examples:* *Because the school bus broke down, the team rode in a van, and the cheerleaders rode in cars.*

Unless my eyes are deceiving me, Kristi is on that runaway horse, and Dale is behind her.

SPELLING RULES

Write *i* before *e* except after *c*, or when sounded like *a* as in *weigh* and *eight*.

→ *Exceptions:* seize, weird, either, leisure, neither

When the *ie/ei* combination is not pronounced *ee*, it is usually spelled *ei*.

→ *Examples:* reign, weigh, neighbor

→ *Exceptions:* friend, view, mischief, fiery

When a multi-syllable word ends in a consonant preceded by one vowel, the accent is on the last syllable and the suffix begins with a vowel — the same rule holds true when you double the final consonant.

→ *Examples:* prefer = preferred | allot = allotted | control = controlling

If a word ends with a silent *e*, drop the *e* before adding a suffix that begins with a vowel.

→ *Examples:* use = using | like = liking | state = stating | love = loving

When the suffix begins with a consonant, do not drop the *e*.

→ *Examples:* use = useful | state = statement | nine = ninety

→ *Exceptions:* argument, judgment, truly, ninth

When *y* is the last letter in a word and the *y* is preceded by a consonant, change the *y* to *i* before adding any suffix except those beginning with *i*.

→ *Examples:* lady = ladies | try = tries | happy = happiness | ply = pliable | fly = flying

LANGUAGE ARTS *the writing process*

WRITING VARIABLES

BEFORE BEGINNING ANY ASSIGNMENT, IT WILL HELP YOU TO FOCUS AND REMAIN CONSISTENT IN STYLE IF YOU CONSIDER THE FOLLOWING VARIABLES.

Audience

For whom am I writing? A letter written to your ten-year-old sister will be much different in vocabulary, subject, content, format, and sentence complexity than one written to your senator.

Topic

About what subject should I write? If possible, choose a subject that interests you. Research your subject well.

Purpose

Why am I writing? Have a clear purpose in mind before starting your paper. Are you writing to entertain, instruct, inform, or persuade? Keeping your purpose in mind as you write will result in a paper that is focused and consistent.

Voice

What point of view or “voice” will I use? Writers sometimes write from the point of view of another person rather than from their own point of view. This can add variety and help you see your subject in a new way. Make sure your “voice” remains consistent.

Format

What form will my writing take? Different forms of writing, such as letters, diaries, reports, essays, research papers, etc., have specific requirements. Decide on the form your writing will take, and then make sure you know the requirements for that form of writing.

PLANNING AND WRITING AN ESSAY OR COMPOSITION

- {1} Select a general subject area that interests you.
- {2} Make a list of your thoughts and ideas about the subject.
- {3} Use your list to help focus on a specific topic within the subject area.
- {4} Decide what you want to say about the topic, and write an introductory statement that reflects this purpose.
- {5} Make a list of details to support your statement.
- {6} Arrange the list of details into an outline.
- {7} Do any reading and research necessary to provide additional support for specific areas of your outline. Keep a careful list of all of your sources for your bibliography.
- {8} Write a first draft.
- {9} Revise your first draft, making sure that:
 - (a) The introduction includes a clear statement of purpose.
 - (b) Each paragraph begins with some link to the preceding paragraph.
 - (c) Every statement is supported or illustrated.
 - (d) The concluding paragraph ties all of the important points together, leaving the reader with a clear understanding of the meaning of the essay or composition.
 - (e) Words are used and spelled correctly.
 - (f) Punctuation is correct.
- {10} Read your revised paper aloud to check how it sounds.
- {11} Proofread your revised paper two times: once for spelling, punctuation, and word usage, and again for meaning and effectiveness.



SCIENCE *Periodic table of the elements*

GROUP	1	2	Transition Metals										11	12	13-18						
IA ***	IIA ***	Transition Metals										IIIB	IIIB	IIIA	IVA	VA	VIA	VIIA	VIIIA		
	1	2	3	4	5	6	7	8	9	10	11	12	13	14	15	16	17	18			
	H	He	Sc	Ti	V	Cr	Mn	Fe	Co	Ni	Cu	Zn	Ga	Ge	As	Se	Br	Kr			
	hydrogen	helium	scandium	titanium	vanadium	chromium	manganese	iron	cobalt	nickel	copper	zinc	gallium	germanium	arsenic	selenium	bromine	krypton			
	1.008	4.003	44.96	47.87	52.00	52.00	54.94	55.85	58.93	58.69	63.55	65.38(2)	69.72	72.63	74.92	78.97	79.90	83.80			
	3	4	3b	4b	4c	4d	4e	4f	4g	4h	4i	4j	4k	4l	4m	4n	4o	4p			
	Li	Be	Y	Zr	Nb	Mo	Tc	Ru	Rh	Pd	Ag	Cd	In	Sn	Sb	Te	I	Xe			
	lithium	beryllium	yttrium	zirconium	niobium	molybdenum	technetium	ruthenium	rhodium	palladium	silver	cadmium	indium	tin	antimony	tellurium	iodine	xenon			
	6.941(1)	9.012	88.91	91.22	92.91	95.95	(98)	101.1	102.9	106.4	107.9	112.4	114.8	118.7	121.8	127.6	126.9	131.3			
	5	6	5b	6b	6c	6d	6e	6f	6g	6h	6i	6j	6k	6l	6m	6n	6o	6p			
	Rb	Sr	Ra	Hf	Ta	W	Re	Os	Ir	Pt	Au	Hg	Tl	Pb	Bi	Po	At	Rn			
	rubidium	strontium	radium	hafnium	tantalum	tungsten	rhenium	osmium	iridium	platinum	gold	mercury	thallium	lead	bismuth	polonium	astatine	radon			
	85.47	87.62	226	178.5	180.9	183.8	186.2	192.2	195.1	197.0	200.6	204.4	208.98	207.2	209.0	(209)	(210)	(222)			
	7	8	7b	8b	8c	8d	8e	8f	8g	8h	8i	8j	8k	8l	8m	8n	8o	8p			
	Fr	Ra	Ac	Rf	Db	Sg	Bh	Hs	Mt	Ds	Rg	Cn	Nh	Fl	Mc	Lv	Ts	Og			
	francium	radium	actinoids	rutherfordium	dubnium	seaborgium	bohrium	hassium	meitnerium	darmstadtium	roentgenium	copernicium	nihonium	flerovium	moscovium	liverngium	tennessine	oganesson			
	(223)	(226)	(227)	(267)	(268)	(271)	(272)	(270)	(276)	(281)	(286)	(289)	(284)	(288)	(288)	(293)	(294)	(294)			
1	H	He	Sc	Ti	V	Cr	Mn	Fe	Co	Ni	Cu	Zn	Ga	Ge	As	Se	Br	Kr			
2	Li	Be	Y	Zr	Nb	Mo	Tc	Ru	Rh	Pd	Ag	Cd	In	Sn	Sb	Te	I	Xe			
3	Na	Mg	La	Ce	Pr	Nd	Pm	Sm	Eu	Gd	Tb	Dy	Ho	Er	Tm	Yb	Lu				
4	K	Ca	Sc	Ti	V	Cr	Mn	Fe	Co	Ni	Cu	Zn	Ga	Ge	As	Se	Br	Kr			
5	Rb	Sr	Y	Zr	Nb	Mo	Tc	Ru	Rh	Pd	Ag	Cd	In	Sn	Sb	Te	I	Xe			
6	Cs	Ba	La	Ce	Pr	Nd	Pm	Sm	Eu	Gd	Tb	Dy	Ho	Er	Tm	Yb	Lu				
7	Fr	Ra	Ac	Rf	Db	Sg	Bh	Hs	Mt	Ds	Rg	Cn	Nh	Fl	Mc	Lv	Ts	Og			

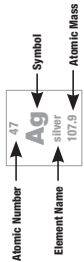

Group IA (excluding Hydrogen) comprises the alkali metals.
 Group IIA comprises the alkaline-earth metals.
 Group VIIIA comprises the noble gases.



* IUPAC conventional atomic weights: standard atomic weights for these elements are expressed in intervals; see iupac.org for an explanation and values. ** Numbering system adopted by IUPAC. *** Numbering system widely used from the mid-20th century. () Indicate the mass number of the longest-lived isotope.

Source: The International Union of Pure and Applied Chemistry (IUPAC), Encyclopaedia Britannica, and others.

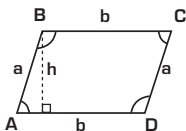
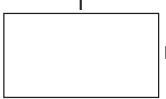
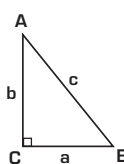
MATHEMATICS *area & volume*

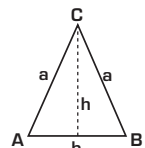
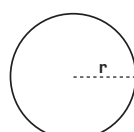
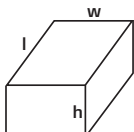

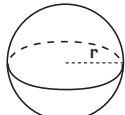
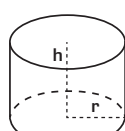
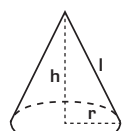
<p>PARALLELOGRAM</p>  <p>Area of ABCD = bh</p>	<p>RECTANGLE</p>  <p>Perimeter = $2(l + h)$ Area = $l \times h$</p>	<p>RIGHT TRIANGLE</p>  <p>Area = $ab/2$ $c^2 = a^2 + b^2$ (Pythagorean Theorem)</p>
---	---	---

<p>ISOSCELES TRIANGLE</p>  <p>Area = $bh/2$</p>	<p>CIRCLE</p>  <p>Circumference of a circle = $2\pi r$ Area of a circle = πr^2</p>	<p>RECTANGULAR PRISM</p>  <p>Surface area of a prism = $2(wl + lh + wh)$ Volume of a prism = $l \times w \times h$</p>
--	---	--

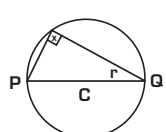
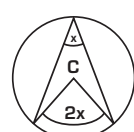
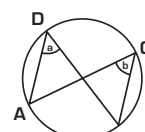
<p>SPHERE</p>  <p>Surface area of a sphere = $4\pi r^2$ Volume of a sphere = $4\pi r^3/3$</p>	<p>CYLINDER</p>  <p>Surface area of a cylinder = $2\pi rh + 2\pi r^2$ Volume of a cylinder = $\pi r^2 h$</p>	<p>CONE</p>  <p>Surface area of a cone = $\pi rl + \pi r^2$ (l = slant height) Volume of a cone = $\pi r^2 h/3$</p>	<p>PYRAMID</p>  <p>Surface area of a pyramid = $B + \text{Lateral Area}$ (Lateral area = sum of triangular faces) Volume of a pyramid = $Bh/3$ (B = area of base)</p>
--	---	---	---

<p>CIRCLE THEOREMS</p>  <p>$\angle x = 90^\circ$ (PQ is the diameter)</p>	 <p>C is the center of the circle</p>	 <p>$\angle a = \angle b$ (Both angles intercept arc AB)</p>
--	--	--

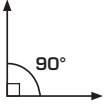
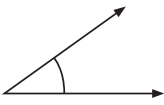
MATHEMATICS *geometric angles & congruence cases*

GEOMETRIC ANGLES			
 <p>A right angle is exactly 90°</p>	 <p>An acute angle is less than 90°</p>	 <p>An obtuse angle is greater than 90°</p>	 <p>A straight angle is exactly 180°</p>

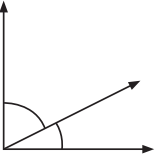
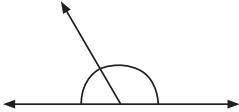
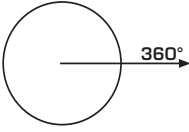
 <p>Complementary angles add up to 90°</p>	 <p>Supplementary angles add up to 180°</p>	 <p>One complete angle of rotation = 360°</p>
---	--	--

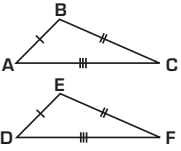
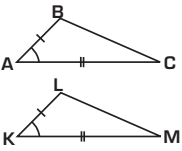
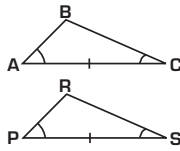
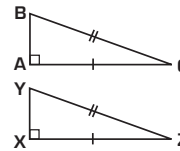
GEOMETRIC CONGRUENCE CASES			
<p>S.S.S. POSTULATE</p>  <p>Side-Side-Side $\triangle ABC \cong \triangle DEF$</p>	<p>S.A.S. POSTULATE</p>  <p>Side-Angle-Side $\triangle ABC \cong \triangle KLM$</p>	<p>A.S.A. POSTULATE</p>  <p>Angle-Side-Angle $\triangle ABC \cong \triangle PRS$</p>	<p>H.S. POSTULATE (RIGHT Δ'S ONLY)</p>  <p>Hypotenuse-side $\triangle ABC \cong \triangle XYZ$</p>

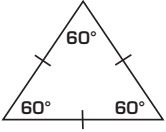
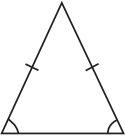
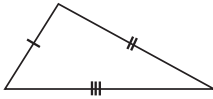
<p>EQUILATERAL TRIANGLE</p>  <p>3 Sides of Equal Length 3 Angles of 60° Each</p>	<p>ISOSCELES TRIANGLE</p>  <p>2 Sides of Equal Length 2 Base Angles are Equal</p>	<p>SCALENE TRIANGLE</p>  <p>3 Unequal Sides 3 Unequal Angles</p>
---	--	---

