

FOODSERVICE EQUIPMENT ARRANGEMENT PLAN

1/4" = 1'-0"

FOODSERVICE EQUIPMENT SCHEDULE

NO.	DESCRIPTION
01	WALK-IN COOLER, FREEZER - EXISTING
02	WASHER BY THE QUINER
03	DRYER BY THE QUINER
04	WALK-IN FREEZER
05	MOBI PLAN RACK
06	POT SINK
07	RASH CAN
08	MOBILE DRYING RACKS
09	MOBILE UTILITY CARTS
10	MOBILE UTILITY CARTS
11	HAND SINK
12	MOBILE COOLING RACKS
13	MOBILE COOLING RACKS
14	VARIO FRO L
15	MOBILE RANGE
16	MOBILE RANGE SECTION OVEN
17	VENTILATOR BY THE MECHANICAL CONTRACTOR
18	FIRE SUPPRESSION SYSTEM BY THE MECHANICAL CONTRACTOR
19	MOBILE PROOF/HOT CABINET
20	NUMBER NOT USED
21	ICE MAKER
22	WORK TABLE
23	MOBILE PLAGS-THRU HOT CABINET
24	COOK'S TABLE
25	MOBILE SERVING LINE
26	PROP-IN HOT FOOD WELLS
27	PROP-IN HOT FOOD WELLS
28	PROP-IN COLD FOOD WELLS
29	PROP-IN COLD FOOD WELLS
30	NUMBER NOT USED
31	MOBILE CASHIER COUNTER
32	PROP BY THE QUINER
33	MOBILE MILK COOLER

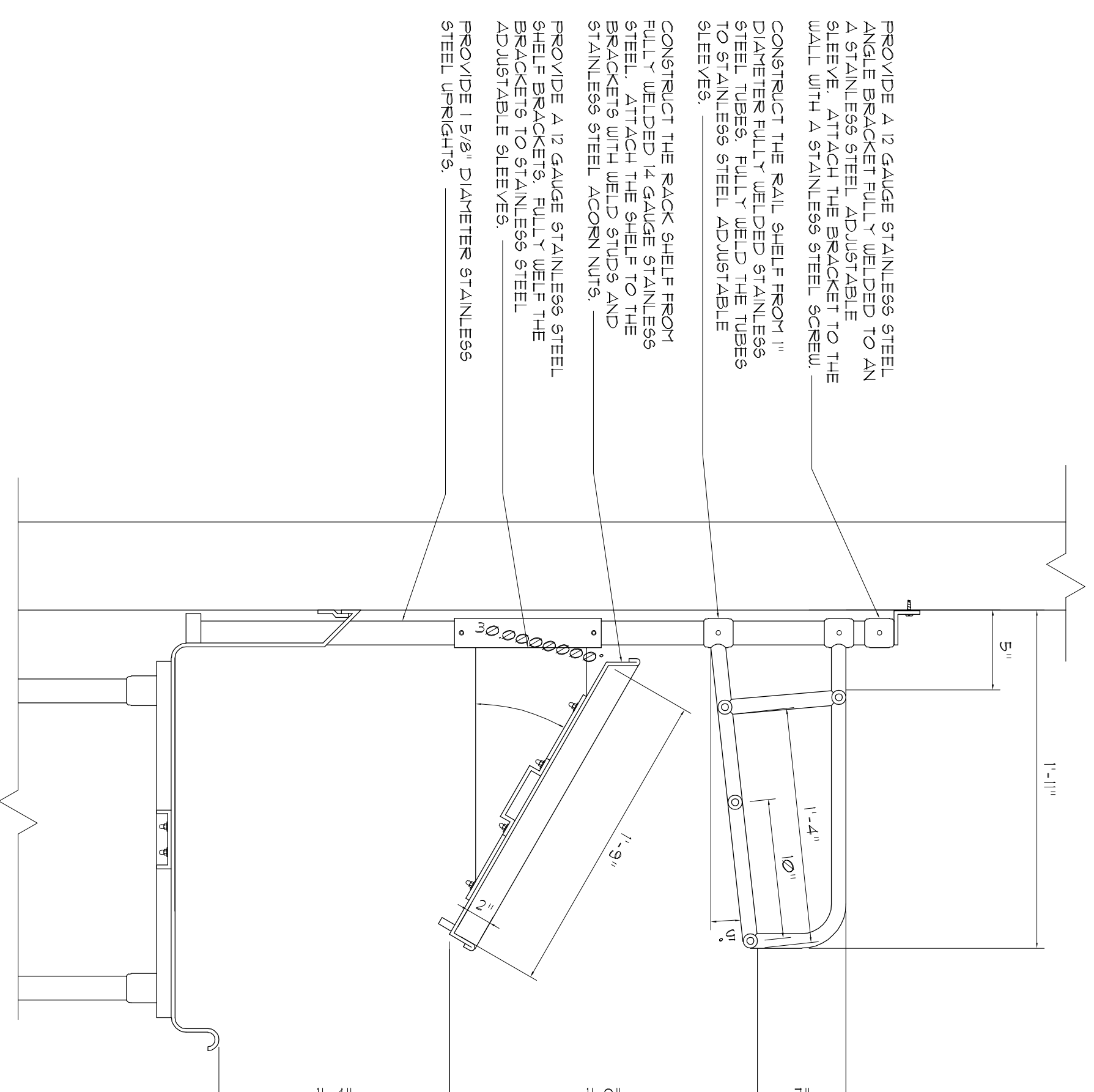

SECTION - SOILED DISHTABLE RACK & RAIL SHELVES

NO SCALE

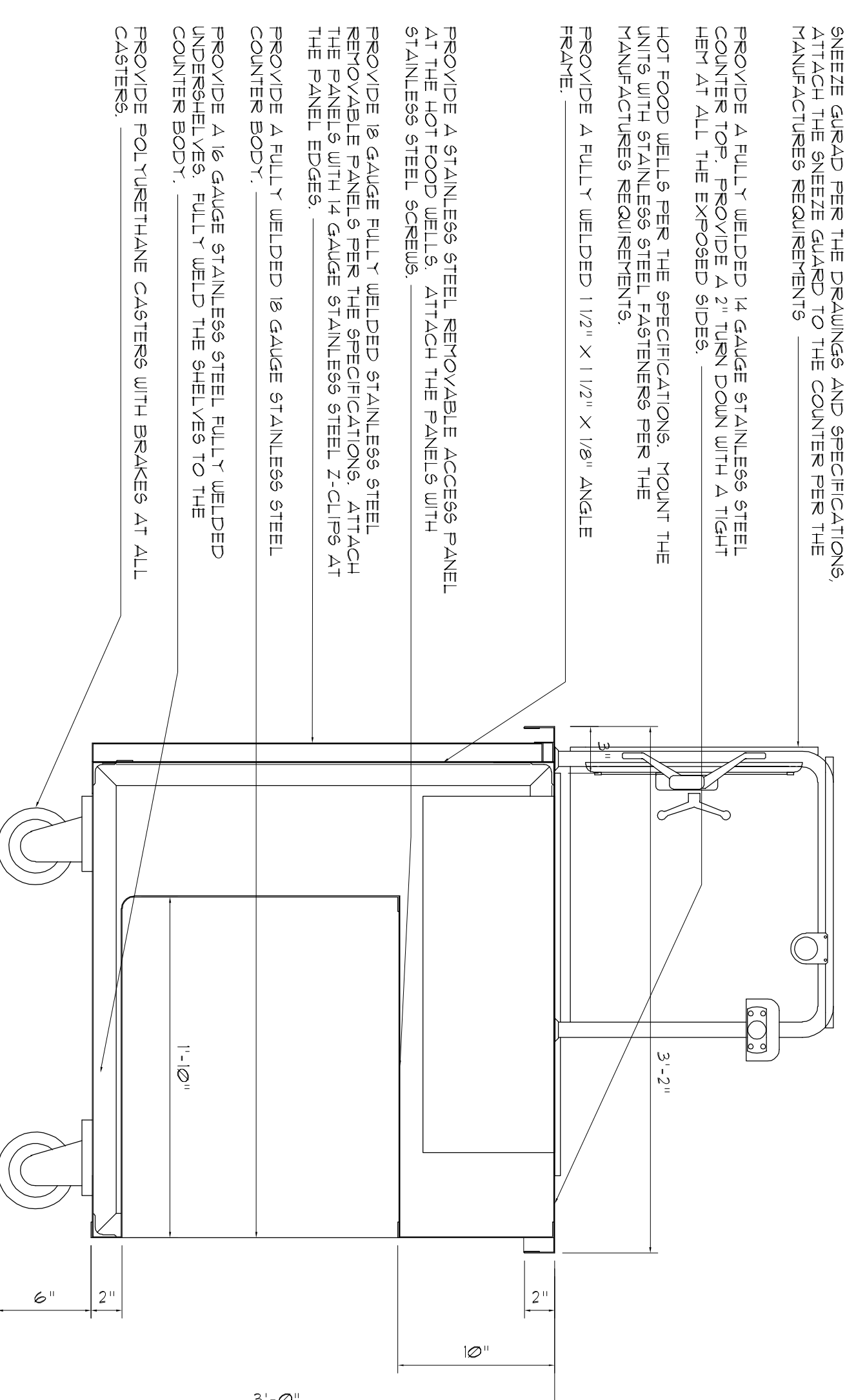

SECTION - SERVING COUNTER

NO SCALE

SHEET GUARD PER THE DRAWINGS AND SPECIFICATIONS, MANUFACTURER'S REQUIREMENTS OF THE COUNTER PER THE MANUFACTURER'S REQUIREMENTS.

PROVIDE A FULLY WELDED 14 GAUGE STAINLESS STEEL COUNTER TOP. PROVIDE A 2" TURN DOWN WITH A TIGHT HENT AT ALL THE EXPOSED SIDES.

HOT FOOD WELLS PER THE SPECIFICATIONS. MOUNT THE UNITS WITH STAINLESS STEEL FASTENERS PER THE MANUFACTURER'S REQUIREMENTS.

PROVIDE A FULLY WELDED 1 1/2" X 1 1/2" X 1/8" ANGLE FRAME.

PROVIDE A STAINLESS STEEL REMOVABLE ACCESS PANEL AT THE HOT FOOD WELLS. ATTACH THE PANELS WITH STAINLESS STEEL SCREWS.

PROVIDE 1/8 GAUGE FULLY WELDED STAINLESS STEEL BRACKET FASTENERS TO ATTACH THE PANELS WITH 14 GAUGE STAINLESS STEEL CLIPS AT THE PANEL EDGES.

PROVIDE A FULLY WELDED 1/8 GAUGE STAINLESS STEEL COUNTER BODY.

PROVIDE A 1/8 GAUGE STAINLESS STEEL FULLY WELDED UNDERSHELVE. FULLY WELD THE SHELVES TO THE COUNTER BODY.

PROVIDE POLYURETHANE CASTERS WITH BRAKES AT ALL CASTERS.

STURM CONSULTING, INC.
FOODSERVICE DESIGN & PLANNING

5838 SOUTH HUDSON PLACE
TULSA, OKLAHOMA 74135
PHONE (918) 260-0667
rockysturm@cox.net

STURM CONSULTING, INC.
FOODSERVICE DESIGN & PLANNING

BELL ELEMENTARY SCHOOL
6304 E. ADMIRAL BLVD., TULSA, OKLAHOMA, 74115

FOODSERVICE EQUIPMENT ARRANGEMENT PLAN

REVISIONS DATE	BY	SW
12/08/2021	RS	Δ

DATE	09/30/2022
DESIGNER	RJS
DRAWN BY	RJS
SCALE	SCALE
DATE	2022.25

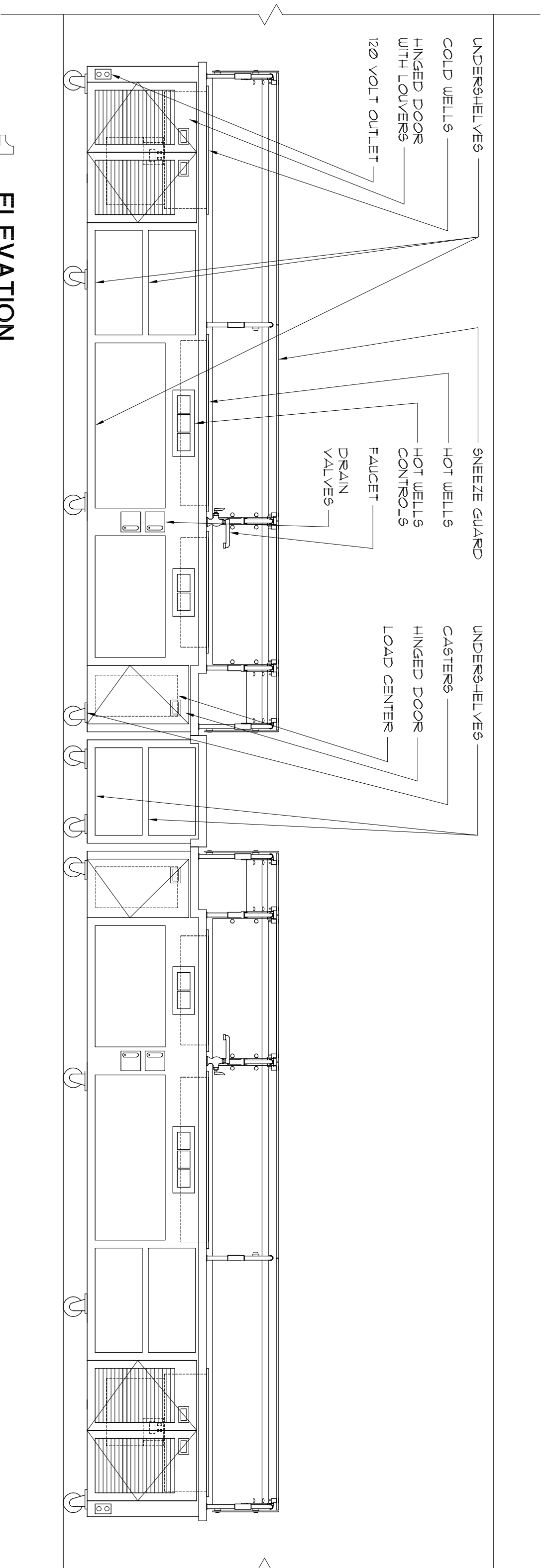

1
ELEVATION
1/2" = 1'-0"

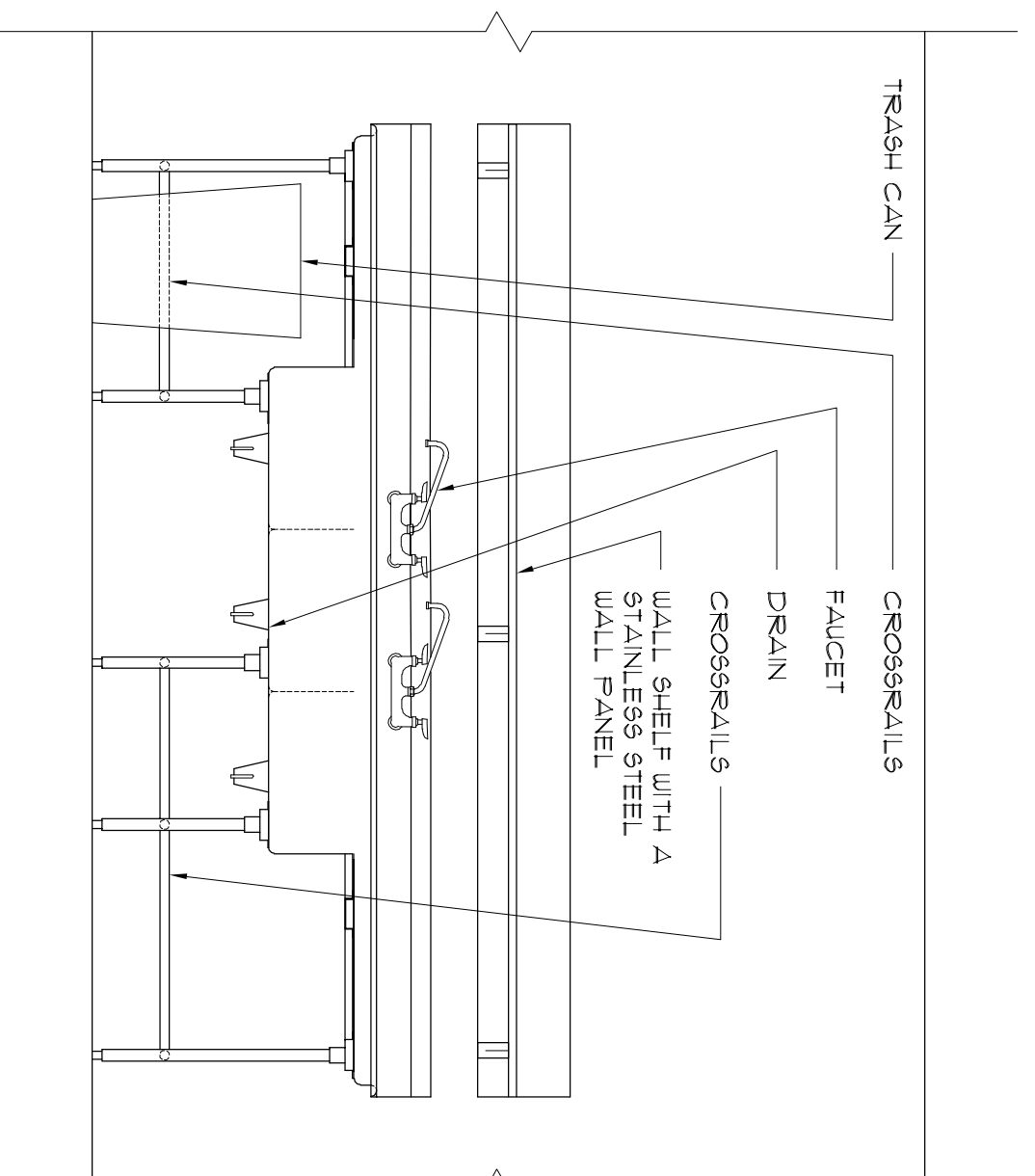

2
ELEVATION
1/2" = 1'-0"

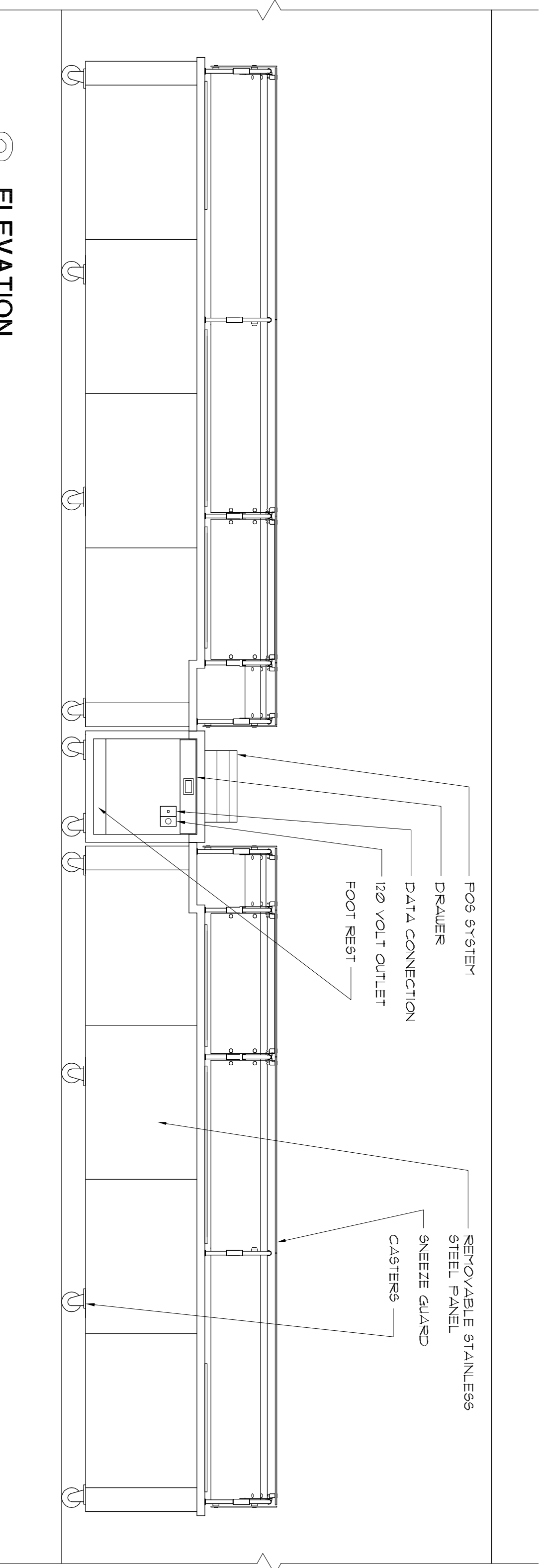

3
ELEVATION
1/2" = 1'-0"

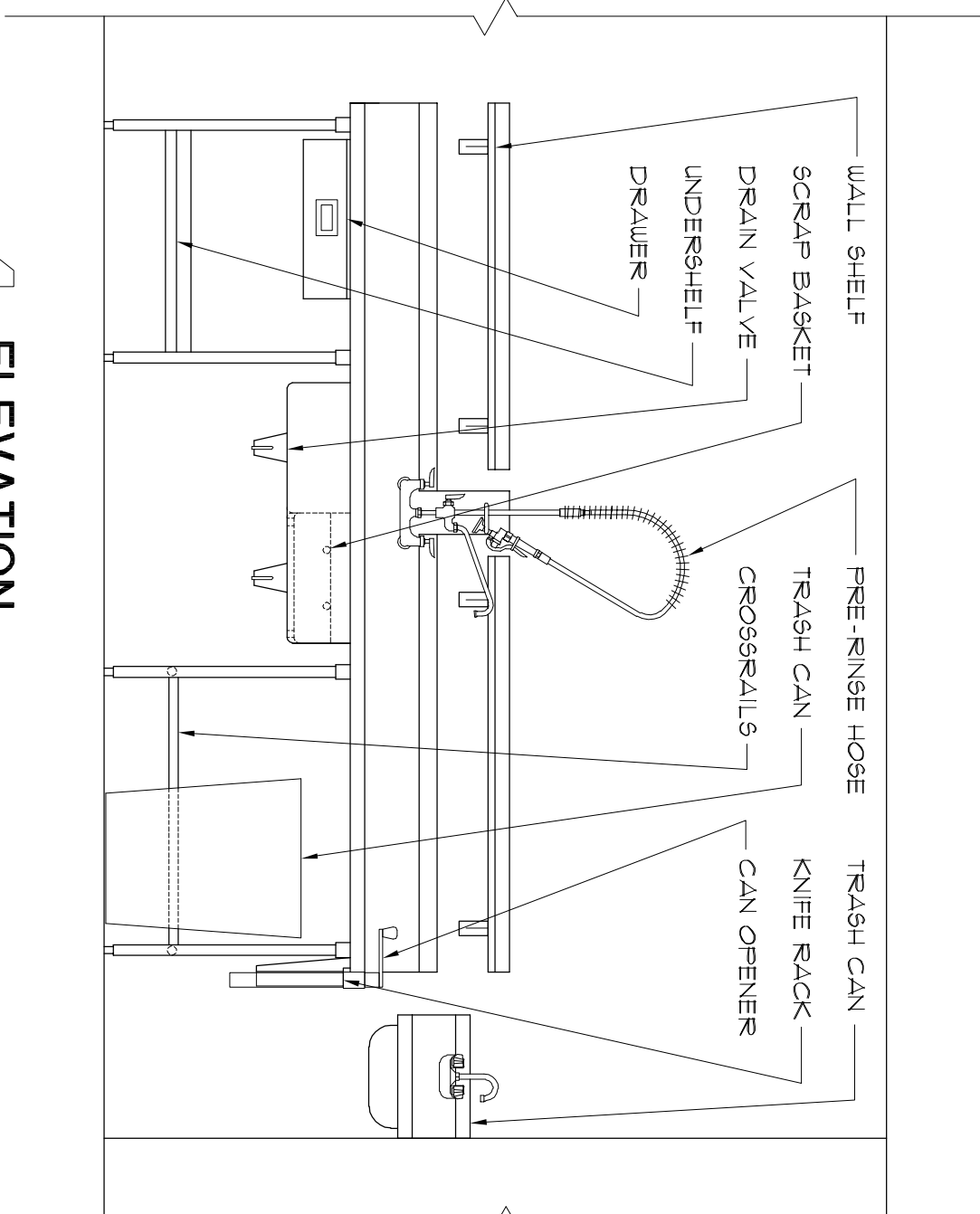

4
ELEVATION
1/2" = 1'-0"

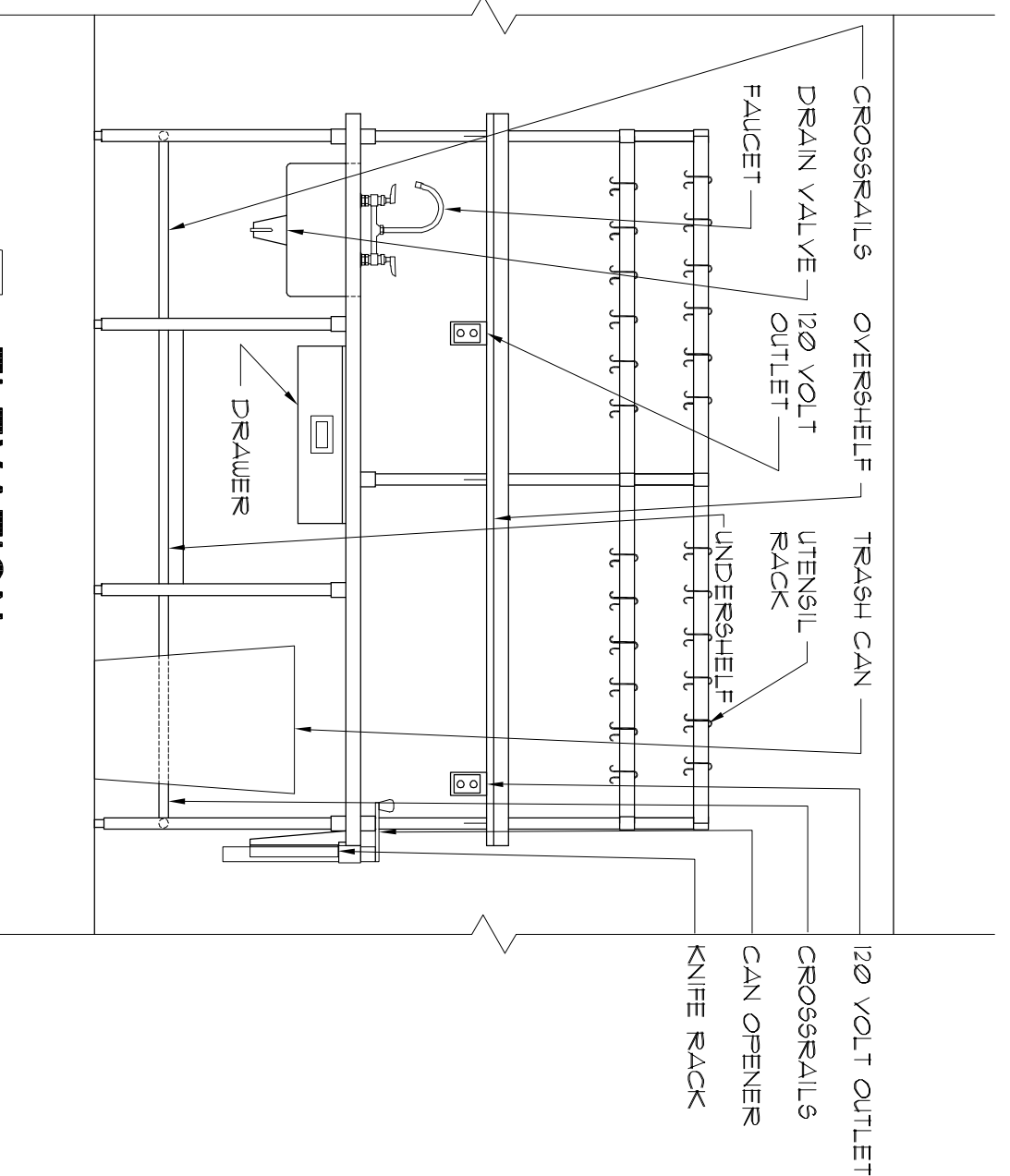

5
ELEVATION
1/2" = 1'-0"

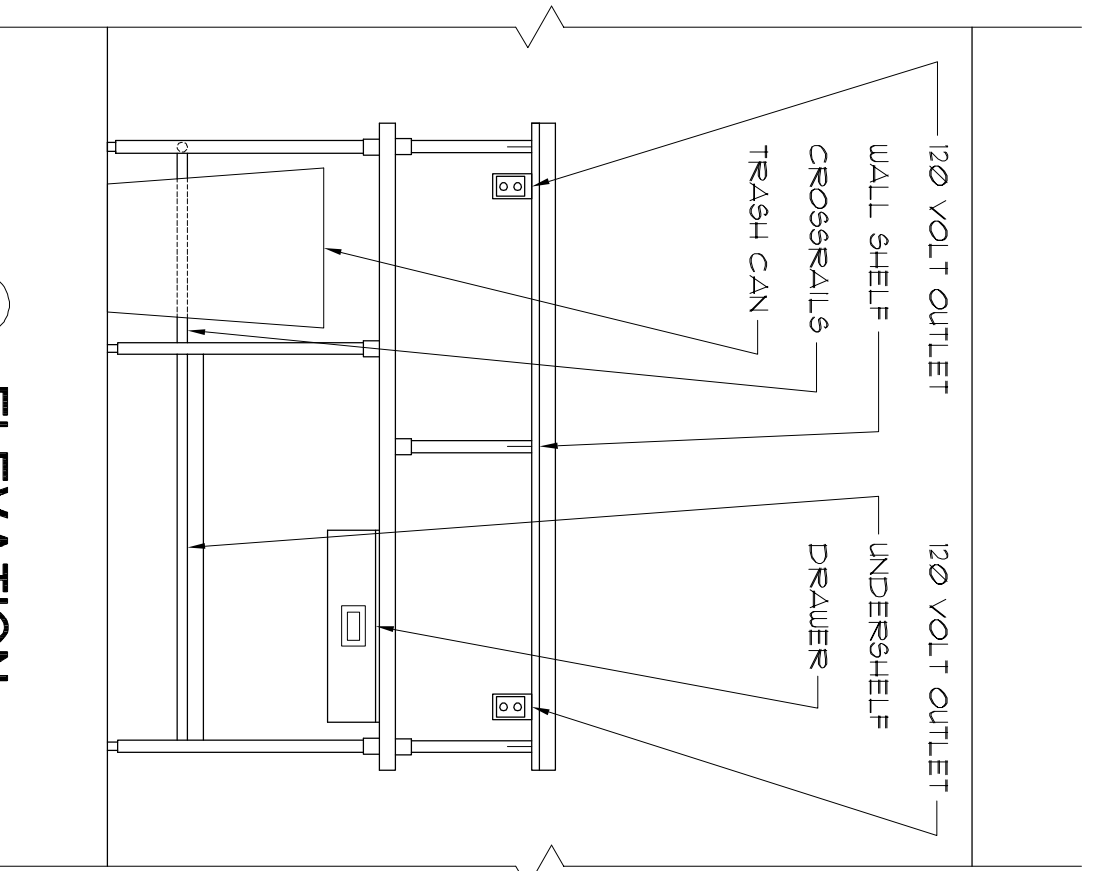

6
ELEVATION
1/2" = 1'-0"

STURM CONSULTING, INC.
FOODSERVICE DESIGN & PLANNING

STURM CONSULTING, INC.
FOODSERVICE DESIGN & PLANNING

5838 SOUTH HUDSON PLACE
TULSA, OKLAHOMA 74135
PHONE (918) 260-0667
rockysturm@cox.net

REVISIONS DATE	BY	SYM
12/08/2021	RS	Δ

BELL ELEMENTARY SCHOOL
6304 E. ADMIRAL BLVD., TULSA, OKLAHOMA, 74115

FOODSERVICE EQUIPMENT ELEVATIONS

DATE	09/30/2022
DESIGNER	RJS
DRAWN BY	RJS
SCALE	SCALE
PROJECT	FS12
DATE	2022.25

SECTION 11 40 00

KITCHEN EQUIPMENT

PART 1 – GENERAL

1.01 SCOPE

- A. Include the work specified, shown or reasonably inferred as part of the foodservice equipment. Portions of the work may be subcontracted to those qualified to do the work as required by jurisdictional trade agreements and restrictions.
- B. Kitchen equipment furnished and installed by the Foodservice Contractor In the base bid.
- C. Provide itemized pricing providing both each pricing and total pricing for every item specified with a bid grand total.

1.02 RELATED SECTIONS

- A. Division 15 – Mechanical rough-ins, inter-connections of the equipment as required and final connections.
- B. Division 16 – Electrical rough-ins, inter-connections of the equipment as required and final connections.

1.03 QUALITY ASSURANCE

- A. All equipment and associated work must comply with all applicable laws, statutes, building codes and regulations of public authorities and comply with the following:
 - a. NSF (National Sanitation Foundation). All the equipment must bear the NSF label.
 - b. NEC (National electric Code).
 - c. UL (Underwriter's Laboratories, Inc.).
 - d. AGA (American Gas Association Laboratories).
 - e. NFPA (National Fire Protection Association).
- B. The following are approved fabricators for providing the fabricated food service equipment:

Jero Manufacturing, Inc.
5117 South 100th East Avenue
Tulsa, Oklahoma 74115

Stainless Innovations
1110 Carnall
Fort Smith, Arkansas 72901

1.04 SUBSTITUTIONS

- A. Equipment items and the components specified are intended to be the basis of the bid. All other manufactures, including manufactures which may be listed as "alternates" or "approved equals" must conform with the specifications, size, accessories, etc. of the original manufacture specified.
- B. Proposed substitutions will be substituted no later then fourteen (14) days prior to the bid date. Submit the proposed substitutions with the manufactures specification or catalog

sheets, shop drawings, etc. indicating all modifications required to conform to the specified items.

- C. Approved substitutions will be addressed in an addendum(s). Approved substitutions will be noted on the bid form as a substitution. All costs and fees for any design and engineering services required to make adjustments to the space, systems, utilities, etc. will be the responsibility of the successful bidder. All costs incurred for modifications of the utilities or construction or professional services will be the responsibility of the successful bidder.
- D. The Owner reserves the right to accept or reject any or all of the substitutions proposed before the execution of the contract.

1.05 DOCUMENT INTERPERTATION

- A. An addendum(s) will be issued addressing questions and comments from contractors, suppliers or vendors pertaining to the intent or clarity of the construction documents.
- B. All questions and comments will be submitted in writing by the contractors, suppliers and vendors for review.

1.06 SUBMITTALS

- A. Submit brochure books, rough-in drawings, fabrication shop drawings and manufactures shop drawings. Refer to the general specifications for the required quantities.
 - a. Brochures:
 - 01 Provide with a front and rear cover. Label the front cover with the project name.
 - 02 Provide a cover sheet for each item number. The cover sheet will indicate the item number, the item name, the quantity, the manufacture, all optional equipment and accessories, specified modifications, the utility requirements and any special instructions.
 - 03 The manufactures catalog specification sheets.
 - b. Submittal drawings:
 - 01 Indicate all equipment shown on the contract documents drawn at a 1/4" scale.
 - 02 The contract documents are not to be traced or reproduced.
 - 03 Provide an equipment schedule indicating all the equipment shown on the contract documents.
 - 04 Drawings to be submitted on the same size drawing sheet as the Contract Documents in a PDF format. Provide the necessary required hard copies of the reviewed/stamped document to the General Contractor. Submit the drawings separately from the Brochure Book.
 - c. Rough-in drawings:
 - 01 Indicate all equipment shown on the contract documents drawn at a 1/4" scale.
 - 02 indicate all general use and convenience utilities indicated on the contract documents.
 - 03 Include utilities shown on the contract documents but connected to equipment not furnished in this section.
 - 04 Fully dimension all the utilities for the plumbing, electrical and mechanical from the finished room surface to the point of the stub-up through the floor and the stub-out through the wall or ceiling.

05 Drawings to be submitted on the same size drawing sheet as the Contract Documents in a PDF format. Provide the necessary required hard copies of the reviewed/stamped document to the General Contractor. Submit the drawings separately from the Brochure Book.

d. Manufacture's and fabricators shop drawings:

01 Indicate all equipment shown on the contract documents drawn at a 3/4" scale for the plan views and elevations. All sections and details to be drawn at a minimum of 1 1/2" scale.

02 Include the equipment name, the item number and the quantity on the drawings.

03 Include all required and necessary sections, details and elevations to reflect the drawings and the specifications.

04 Indicate all adjacent equipment, walls and columns.

05 Include all necessary plumbing and electrical schematic drawings.

06 Include any ventilation or access panels as required by the manufactures of the built-in equipment.

07 Drawings to be submitted on the same size drawing sheet as the Contract Documents in a PDF format. Provide the necessary required hard copies of the reviewed/stamped document to the General Contractor. Submit the drawings separately from the Brochure Book.

1.07 COORDINATION OF THE PROJECT AND DATA

A. Review the contract documents, rough-in drawings, shop drawings and brochure books for accuracy and completeness.

a. Notify the Architect of any conflicts and required adjustments in writing.

b. Coordinate the work with this section with the other sub-contractors on the job.

c. Submit paint, stain, plastic laminate, vinyl coated surfaces, molded plastic, natural stone, man-made stone and solid surface material to the Owner for approval.

d. Obtain serviceware samples for sizing and weight information from the Owner for coordination of all self-leveling equipment.

e. Coordinate all mobile equipment will go through doors, wall openings and roll-in/roll-thru equipment. Notify the Architect of all conflicts or deviations from the approved submittals in writing.

1.08 FIELD VERIFICATION OF THE PROJECT AND DATA

A. Review the contract documents, rough-in drawings, shop drawings and brochure books for accuracy and completeness.

a. Field verify all the under-slab rough-in locations and quantities before the concrete slab is poured. Notify the Architect in writing of all conflicts or omissions of the rough-ins.

b. Field verify all the in-slab recess locations, sizes, depths and quantities before the concrete slab is poured. Notify the Architect in writing of all conflicts or omissions of the in-slab recess.

c. Field verify all the in-wall rough-in locations and quantities before the drywall is installed. Notify the Architect in writing of all conflicts or omissions of the rough-ins.

d. Obtain actual field dimensions or guaranteed measurements from the general contractor to insure the proper fit of the equipment at the job site. The dimensions shown in the contract documents are approximate. The dimensions are for the bidding process only.

- e. Field check all dimensions, measurements job site conditions before the fabrication and/or delivery of equipment to the job site. Notify the Architect of all conflicts or deviations from the approved submittals in writing.
- f. Coordinate any exterior wall openings required for the delivery of all oversized equipment with the general contractor. The equipment must be manufactured to fit through standard door openings if this cannot be done.

1.09 WARRANTY

- A. Provide manufacture's warranty on each piece of specified equipment.
- B. The warranty period will be for one year after acceptance from the Owner for parts and labor.
- C. The warranty period will be for five years after acceptance from the Owner for compressor bodies for refrigeration equipment.
- D. The warranty period will be for ten years after acceptance from the Owner for the walk-in panels.

PART 2 – PRODUCTS

2.01 MATERIALS

- A. Stainless steel.
 - a. All stainless steel to 18-8, type 304, polished to a 180 grit number 4 finish unless noted otherwise in the item specifications or in the drawings.
 - b. All seams and joints are to be heli-arc welded completely and free of flaws and pits. Grind the welds smooth and polish to a number 4 finish.
 - c. The grain of the stainless steel is to run the length of the equipment including the backsplash. Provide a polished miter look where the tops form a corner.
- B. Galvanized iron.
 - a. All seams and joints are to be heli-arc welded completely and free of flaws and pits. Grind the welds.
 - b. Thoroughly clean the welded and polished areas and prime and paint with Rustoleum in a color to match the metal.
- C. Sound deadening.
 - a. Apply 1/2" wide Schnee Butyl sealant rope continuously between all bracing/frame members and the underside of the table/counter tops, overshelves, wall shelves and undershelves.
 - b. Weld stud bolts to the underside of the tops, overshelves, wall shelves and undershelves. Tighten the stud bolts for maximum compression of the sound deadening. Trim any excess that extends from out of the bracing.
- D. Shop and field joints.
 - a. Field joints are to be used only when the equipment size must be limited for access into the building.
 - b. Indicate the field joint locations on the shop drawings.

PART 3 – EXECUTION

3.01 INSPECTION

- A. Verify and test that all equipment is plumbed, wired correctly, true and in good working order. Do not use until turned over to the Owner.
- B. Protect all appliances from construction dirt until the project is turned over to the Owner.

3.02 DELIVERY

- A. Coordinate with the construction progress and the Owner's operation schedule. Unless otherwise instructed by the general contractor or the Owner, the following procedures apply.
 - a. Items that integrate into the building, such as, walk-in coolers and freezers, ventilators, hoods, equipment supports, ceiling mounted utensil racks, etc. will be sent to the job site after the building is water tight and directed by the general contractor. Protect the equipment as required after installation is complete.
 - b. All the additional fixed equipment and mobile equipment requiring plumbing and electrical final connections will be delivered to the job site after the completion of the finished floor, wall finish, ceiling grid and tile or drywall and paint and the lighting system.
 - c. The remaining mobile equipment will be delivered to the job site after the equipment can be inventoried and secured in a lockable area. If a secured area is not available, deliver the equipment when the job site when the installation is completed and the equipment clean-up process have been completed.
 - d. Small counter item, pans, flatware containers, etc. will be delivered only when the Owner is ready to receive and inventory the items.

3.03 INSTALLATION

- A. Provide a competent supervisor at the job site during the entire installation process.
- B. Install the equipment per the manufacture's recommendations. Install the equipment square and level. All equipment shall be ready for the final connections.
- C. Protect the equipment after the installation process is complete.
 - a. Protect the custom fabricated equipment with fiberboard or plywood taped to the tops and exposed body surfaces.
 - b. Protect the buy-out equipment with fiberboard or plywood taped to the tops and exposed body surfaces.
 - c. The general contractor must insure the equipment is not used by other sub-contractors as work tables, scaffolding, tool and material storage, etc.
- D. Provide and install 18 gauge stainless steel trim at all gaps between the equipment and the walls and/or other high equipment when the gap is larger than 7/16 of an inch wide. Turn the trim down 90 degrees at the equipment splashes, top and/or turn downs. Attach the trim with hidden fasteners and seal with silicone caulking.

3.04 CLEAN AND ADJUST

- A. Leave the work area clean and free of debris.
- B. Remove or replace panels, parts or frames that are bowed, warped, dented or scratched as a result of manufacturing defects, shipping and delivery to the job site.

- C. The Foodservice Contractor is to deliver the foodservice equipment to the job sites, uncrate the equipment, remove all packing materials from the equipment, set the equipment into place per the floor plan and the job site conditions, level the equipment and make ready for final connection by the Mechanical, Plumbing and/or Electrical Contractor. All crating materials are to be removed from the job site by the Foodservice Contractor.
- D. The Foodservice Contractor will final clean (not sanitizing) the foodservice equipment and seal the fixed foodservice equipment to the adjacent walls and/or fixed equipment with silicone caulking after all the utilities have been connected. The caulking will be neat, smooth and level with the foodservice equipment. Concaved caulking will be rejected. Remove any smeared caulking from the foodservice equipment and adjacent surfaces.

3.05 SERVICE MANUAL

- A. Provide manufacture's warranties and operating manuals on all appliances over to the Owner.
- B. Each appliance shall have operating instructions and maintenance information.
- C. The Foodservice Contractor will furnish to the Owner three (3) copies of an owner's and operations manual. The manual will be in three ring binders. The manuals will include a cover sheet for each equipment item, warranty information sheets, manufactures specification sheets and the service agent's name, address and telephone number.
- D. All warranties are not to begin until after the Owner accepts successful completion of the Start-up Demonstration and the kitchen.

3.06 EQUIPMENT DEMO AND START UP

- A. The Foodservice Contractor must test, adjust and regulate all the equipment per the manufacturer's instructions.
- B. The Foodservice Contractor will schedule, at the Owner's convenience, a date and time to demonstrate the foodservice equipment to the Owner. The Foodservice Contractor will start up and check out the foodservice equipment before the equipment is demonstrated to the Owner.

PART 4 – EQUIPMENT

ITEM NO. 01 - WALK-IN COOLER & FREEZER - EXISTING

ITEM NO. 02 - WASHER BY THE OWNER

ITEM NO. 03 - DRYER BY THE OWNER

ITEM NO. 04 - HAND SINK - EXISTING

ITEM NO. 05 - MOBILE PAN RACK (2 REQUIRED)

Eagle Group Model QUADPLUS mobile pan rack. Provide each unit four (4) shelves with 74" high posts. Mount the bottom shelf at 10" above the finish floor. Mount the remaining shelves at 17" on center.

Accessories

- 8 ea. Model QPF-2436E-GL shelves.
- 8 ea. Model CP74-E posts.

8 ea. Model CSB5P-300 casters with brakes.

ITEM NO. 06 - POT SINK (1 REQUIRED)

Custom fabricated pot sink to be constructed per drawings with a fully welded 14 gauge type 304 stainless steel top. Provide 12 gauge fully welded type 304 stainless steel channel underbracing under top with fully welded closed ends where they are exposed. Sound deadened between top and underbracing.

Features:

- 01 Provide with a 10" high x 2" thick backsplash at walls. Attach back splash to wall with stainless steel screws at a 4'-0" o.c. maximum spacing with 14 gauge stainless steel Z-clips.
- 02 Provide with a 3" high rolled rim at exposed sides. Locate top of rolled rim 3'-1" above finish floor.
- 03 Provide three (3) 26 1/2" front-to-back x 21" x wide x 11" deep sink compartments constructed with 14 gauge type 304 stainless steel fully welded integrally into the top.
- 04 Provide type 304 stainless steel legs with stainless steel leg sockets and adjustable stainless steel bullet feet. Fully weld the leg sockets the underbracing.
- 05 Provide a 16 gauge type 304 stainless steel undershelves per the drawings. Turn the undershelves up 2" at rear and high equipment. Fully weld the undershelves to the legs. Provide 12 gauge fully welded type 304 stainless steel channel underbracing under the undershelves. Sound deadened between the undershelves and the underbracing.
- 06 Provide type 304 stainless steel crossrails per the drawings. Fully weld the crossrails to the legs.
- 07 Provide 1'-1" wide x length indicated on the drawing x 1" diameter fully welded stainless steel three-bar wall shelf at the sinks. Mount the rail shelf 1'-9" above the work surface.
- 08 Support the shelf with 12 gauge type 304 stainless steel angled brackets fully welded to the uprights
- 09 Provide a 14 gauge type 304 stainless steel wall panel behind the shelf per the drawings. Attach the panel to the wall with industrial adhesive.

Accessories

- 2 ea. T & S model B-0290 faucets.
- 3 ea. Component Hardware model DBN-8000 twist waste valve. Shorten the handle to be flush with the front of the sink bowl. Provide 14 gauge type 304 stainless steel brackets to support the handles. Attach to the sink bottom with stainless steel anchors.
- 3 ea. Component Hardware model J19-4962 brackets.

ITEM NO. 07 - TRASH CAN (3 REQUIRED)

Carlisle Foodservice Products model 341032 trash can in a gray color. NSF listed.

Accessories

- 3 ea. Model 341033 GY lid for in a gray color. NSF listed.
- 3 ea. Model 3691003 dolly in a black color.

ITEM NO. 08 - MOBILE TRAY DRYING RACK (2 REQUIRED)

Metro model PR48VX2-XDR with all the standard features.

ITEM NO. 09 - MOBILE UTILITY CART (3 REQUIRED)

Lakeside Manufacturing model 422 with all the standard features.

ITEM NO. 10 - PREP TABLE (1 REQUIRED)

Custom fabricated prep table to be constructed per the drawings with a fully welded 14 gauge type 304 stainless steel top. Provide 12 gauge fully welded type 304 stainless steel channel underbracing under the top with fully welded closed ends where they are exposed. Sound deadened between the top and the underbracing.

Features

- 01 Provide with a 10" high x 1" thick backsplash at the rear and high equipment. Attach the back splash to the wall with stainless steel screws at a 4'-0" o.c. maximum spacing with 14 gauge stainless steel Z-clips.
- 02 Provide with a 2" turn down with a tight hem at the exposed sides.
- 03 Extend splash at pre-rinse faucet per drawings. Extend counter bracing up to top of extension. Fully weld bracing to counter bracing. Provide with a removable finished back where exposed.
- 04 Provide two (2) 18" x 18" x 10" deep 14 gauge type 304 stainless steel sinks fully welded into the top.
- 05 Provide a 5" high 18 gauge 304 stainless steel removable scrap basket. The bottom is to be perforated with 1/4" diameter holes. Provide two (2) type 304 stainless steel 1" diameter tubular handles running from the back to the front of the basket. Provide four (4) type 304 stainless steel 1" tall x 1" diameter tubular legs at the bottom of the basket. The bottom of the legs to be fully welded closed. Fully weld the basket, handles and the legs.
- 06 Provide 1 5/8" diameter type 304 stainless steel legs with stainless steel leg sockets and adjustable stainless steel flanged feet. Anchor the feet to the floor with stainless steel anchors. Fully weld the leg sockets the underbracing. Anchor the feet to the floor with stainless steel fasteners.
- 07 Provide a 16 gauge type 304 stainless steel undershelves per the drawings. Turn the undershelves up 2" at rear. Fully weld the undershelves to the legs. Provide 12 gauge fully welded type 304 stainless steel channel underbracing under the undershelves. Sound deadened between the undershelves and the underbracing.
- 07 Provide type 304 stainless steel crossrails in the locations shown by the drawings. Fully weld the crossrails to the legs.
- 08 Provide two (2) 1'-0" wide x length indicated on the drawing fully welded 16 gauge stainless steel wall mounted overshelf. Provide 12 gauge fully welded type 304 stainless steel wall brackets. Mount the wall shelf 1'-6" above the work surface of the work table with stainless steel screws. Extend the back turn up of the shelves over the top of the overshelves of item 28 1/2" 90 degrees.

Accessories

- 1 ea. T & S model B-0133 pre-rinse faucet.
- 1 ea. T & S model B-0230-K installation kit.
- 1 ea. T & S model B-0156 add-on faucet.
- 1 ea. T & S model B-0109-01 wall bracket. Mount the bracket to the top extension with stainless steel screws.
- 2 ea. Component Hardware model DBN-8000 twist waste valve. Shorten the handle to be flush with the front of the sink bowl. Provide 14 gauge type 304 stainless steel brackets to support the handles. Attach to the sink bottom with stainless steel anchors.

- 1 ea. Edlund model G-2S can opener. Edlund model G-2S manual can opener. Mount to the table in the location shown on the drawings with stainless steel screws per the manufactures requirements. Remove the exposed screw threads below the table top. Widen the underbracing at the can opener to allow clearance for the mounting screws.
- 1 ea. Edlund model KR-699 knife rack. Provide a 14 gauge type 304 stainless steel bracket for the knife holder. Locate the knife holder per the drawings. Attach the rack to the bracket with Component Hardware model Q37-0250 stainless steel keyhole studs welded to the bracket at the top.
- 1 ea. Component Hardware model S90-0020 drawer assembly. Locate the drawer per the drawings.

ITEM NO. 11 - HAND SINK (2 REQUIRED)

Eagle Group model HSA-10 with all the standard features.

Accessories

- 2 ea. Model 300886 drain assembly.
- 2 ea. Model LRS left and right hand splash on the sinks.
- 2 ea. Component Hardware Group, Inc. model KL45-4002-RE1 faucets.
- 2 ea. Component Hardware Group, Inc. model KN91-0100 quik-wash faucet control. Install on the faucets.
- 1 ea. Model eye wash attachment. Install on the sink near item 12.

ITEM NO. 12 - MOBILE COOLING RACKS (2 REQUIRED)

New Age model 1306 with all the standard features.

Accessories

- 2 sets. Provide with polyurethane tired casters with brakes.
- 2 ea. Model PB - Perimeter bumpers.

ITEM NO. 13 - MOBILE COMBI-OVEN (1 REQUIRED)

Rational model ICP 6-FUL/10-FULLL E with all the standard features.

Accessories

- 1 ea. 208 volts, three phase.
- 1 ea. Hinge the doors on the right.
- 1 kt. Model 60.74.725 combi-duo staking kit.
- 1 ea. Model 60.31.635 mobile combi-duo kit.
- 1 lot CAP program.
- 1 lot Model 9999.2271 certified installation.
- 1 ea. Model 8720.1569US installation kit.
- 2 ea. Model 60.76.317 external core temperature probe.
- 1 cs. Model 56.01.535 detergent tablets.
- 1 cs. Model 56.00.598 defoamer tablets.
- 1 cs. Model 56.00.562 care tablets.
- 1 ea. Model 1900.1150US water filter system. Mount the unit on the side of the unit with stainless steel screws.
- 2 ea. Model 1900.1155US replacement cartridges.
- 1 ea. Provide with Dormont model W50BP2Q48PS water hose. Provide to the plumbing contractor for installation.
- 3 ea. Provide with Dormont model W50BP2@48 water hose. Provide to the plumbing contractor for installation.

ITEM NO. 14 - IVARIO PRO L (1 REQUIRED)

Rational model IVARIOPR L with all the standard features.

Accessories

- 1 ea. 208 volts, three phase.
- 1 lot Model CAP Chef assistance program.
- 1 lot Model 9999.2221 certified installation.
- 1 lot Model 9999.2002 pre-installation site consultation.
- 1 lot Model 9999.1009 extended travel zones.
- 1 ea. Model 8730.1565US installation kit.
- 1 ea. Model 1900.1154US water filter system. Mount the unit on the side of the unit with stainless steel screws.
- 1 lot Model 9999.2271 certified installation.
- 1 ea. Model 1900.1155US replacement cartridges.
- 1 kt. Model 60.71.267 caster kit.
- 1 ea. Model 87.00.732US equipment placement system. Attach to the floor per the Manufacture's requirements.
- 1 ea. Model 60.73.920 cleaning kit.
- 1 st. Model 60.71.643 scraper.
- 1 ea. Model 60.73.348 scoop.
- 1 ea. Model 60.73.586 scoop.

ITEM NO. 15 - MOBILE RANGE (1 REQUIRED)

Montague Company model 12-5 with all the standard features.

Accessories

- 1 ea. Natural gas
- 1 ea. Rear gas connection.
- 1 ea. 1" gas regulator.
- 1 ea. 12 equipment stand.
- 1 ea. Polyurethane tired casters with brakes.
- 1 ea. Dormont model 16100KIT2S48PS gas connector hose kit. Provide to the plumbing contractor for installation.

ITEM NO. 16 - CONVECTION OVEN (1 REQUIRED)

Blodgett Oven model DFG100 DOUBLE with all the standard features.

Accessories

- 1 ea. Natural gas.
- 1 ea. 120 volts, single phase.
- 1 ea. SSD controls.
- 1 ea. Draft diverter.
- 1 sets Polyurethane casters with brakes.
- 1 ea. Provide with Dormont model 1675KIT2S48 gas hoses. Provide to the plumbing contractor for installation.
- 1 ea. Provide with Dormont model 1675KIT2S48PS gas hoses. Provide to the plumbing contractor for installation.

ITEM NO. 17 - VENTILATOR BY THE MECHANICAL CONTRACTOR

ITEM NO. 18 - FIRE SUPPRESSION SYSTEM BY THE MECHANICAL CONTRACTOR

ITEM NO. 19 - MOBILE PROOF/HOT CABINET (2 REQUIRED)

CresCor model 121-PH-UA-11D with all the standard features.

Accessories

- 2 ea. 120 volts, single phase.
- 2 ea. Model 1405-135 perimeter bumper
- 2 sets Provide with 5" polyurethane casters with brakes on all the casters.

ITEM NO. 20 - NUMBER NOT USED

ITEM NO. 21 - ICE MAKER (1 REQUIRED)

Manitowoc model IYT0420A with all the standard features.

Accessories

- 1 ea. 120 volts, single phase.
- 1 ea. Model D420 ice bin.
- 1 ea. Stainless steel legs.
- 1 ea. Everpure model EV932401 water filter assembly. Mount on the side of the ice maker and bin with stainless steel screws.
- 1 ea. Everpure model EV961222 i2000 replace cartridge.

ITEM NO. 22 - MOBILE PASS-THRU REFRIGERATOR (2 REQUIRED)

Continental Refrigerator model D1RENSSPTHD with all the standard features.

Accessories

- 2 ea. Hinge the doors per the drawings.
- 2 ea. 120 volts, single phase with a cord and plug.
- 4 ea. Half height glass doors on the kitchen side.
- 2 ea. Model 50-P008A-E universal type pan slides.
- 2 ea. Space all slides equally throughout the cabinets.
- 2 sets 5" polyurethane casters with brakes on all casters.

ITEM NO. 23 - WORK TABLE (1 REQUIRED)

Custom fabricated work table to be constructed per the drawings with a fully welded 14 gauge type 304 stainless steel top. Provide 12 gauge fully welded type 304 stainless steel channel underbracing under the top with fully welded closed ends where they are exposed. Sound deadened between the top and the underbracing.

Features

- 01 Provide with a 2" turn down with a tight hem at the exposed sides.
- 02 Provide 1 5/8" diameter type 304 stainless steel legs with stainless steel leg sockets and adjustable stainless steel flanged feet. Fully weld the leg sockets the underbracing. Anchor the feet to the floor with stainless steel fasteners.
- 03 Provide a 16 gauge type 304 stainless steel undershelves per the drawings. Turn the undershelves up 2" at walls and high equipment. Fully weld the undershelves to the legs. Provide 12 gauge fully welded type 304 stainless steel channel underbracing under the undershelves. Sound deadened between the undershelves and the underbracing.
- 04 Provide type 304 stainless steel crossrails per the drawings. Fully weld the crossrails to the legs.

- 05 Provide a 1'-0" wide x length indicated on the drawing fully welded 16 gauge stainless steel cantilevered overshelf. Mount the overshelf 1'-6" above the work surface of the work table with stainless steel screws. Provide a 16 gauge type 304 stainless steel finished back on the exposed backsplash fully welded to the shelf turn-up.
- 06 Support the shelf with 12 gauge type 304 stainless steel angled brackets fully welded to the uprights. Attach the shelf to the brackets with stainless steel acorn nuts in two (2) places at each bracket.

Accessories

- 1 ea. Component Hardware model S90-0020 drawer assembly. Locate the drawer per the drawings.
- 2 ea. Component Hardware Model R58-1010 electrical outlet box at the microwave oven. Attach the boxes to the overshelf with stainless steel fasteners per the manufacturer's requirements. Provide with stainless steel cover plates. Provide and install conduit in an unexposed manner from the box through the shelf upright to a 4x4 junction box mounted below the table top.

ITEM NO. 24 - MOBILE PASS-THRU HOT CABINET (2 REQUIRED)

Continental Refrigerator model DL1WE-SS-PT-HD with all the standard features.

Accessories

- 2 ea. Hinge the doors per the drawings.
- 2 ea. 208 volts, single phase with a cord and plug.
- 4 ea. Half height glass doors on the kitchen side.
- 2 ea. Model 50-P008A-E universal type pan slides.
- 2 ea. Space all slides equally throughout the cabinets.
- 2 sets 5" polyurethane casters with brakes on all casters.

ITEM NO. 25 - COOK'S TABLE (1 REQUIRED)

Custom fabricated cook's table to be constructed per the drawings with a fully welded 14 gauge type 304 stainless steel top. Provide 12 gauge fully welded type 304 stainless steel channel underbracing under the top with fully welded closed ends where they are exposed. Sound deadened between the top and the underbracing.

Features

- 01 Provide with a 2" turn down with a tight hem at the exposed sides.
- 02 Provide one (1) 18" front-to-back x 18" wide x 10" deep sink compartment constructed with 14 gauge type 304 stainless steel fully welded integrally into the top.
- 03 Provide 1 5/8" diameter type 304 stainless steel legs with stainless steel leg sockets and adjustable stainless steel flanged feet. Anchor the feet to the floor with stainless steel anchors. Fully weld the leg sockets the underbracing. Anchor the feet to the floor with stainless steel fasteners.
- 04 Provide a 16 gauge type 304 stainless steel undershelves per the drawings. Turn the undershelves up 2" at walls and high equipment. Fully weld the undershelves to the legs. Provide 12 gauge fully welded type 304 stainless steel channel underbracing under the undershelves. Sound deadened between the undershelves and the underbracing.
- 05 Provide type 304 stainless steel crossrails per the drawings. Fully weld the crossrails to the legs.
- 06 Provide a 1'-0" wide x length indicated on the drawing fully welded 16 gauge stainless steel cantilevered overshelf. Mount the overshelf 1'-6"

- above the work surface of the work table with stainless steel screws. Provide a 16 gauge type 304 stainless steel finished back on the exposed backsplash fully welded to the shelf turn-up.
- 07 Support the shelf with 12 gauge type 304 stainless steel angled brackets fully welded to the uprights. Attach the shelf to the brackets with stainless steel acorn nuts in two (2) places at each bracket.

Accessories

- 1 ea. T & S model B-0320 faucets.
- 1 ea. Component Hardware model DBN-8000 twist waste valve. Shorten the handle to be flush with the front of the sink bowl. Provide 14 gauge type 304 stainless steel brackets to support the handles. Attach to the sink bottom with stainless steel anchors.
- 1 ea. Advance Tabco model SWT-108 wall mounted pot rack. Modify the length per the drawings.
- 1 ea. Edlund model G-2S can opener. Edlund model G-2S manual can opener. Mount to the table in the location shown on the drawings with stainless steel screws per the manufactures requirements. Remove the exposed screw threads below the table top. Widen the underbracing at the can opener to allow clearance for the mounting screws.
- 1 ea. Edlund model KR-699 knife rack. Provide a 14 gauge type 304 stainless steel bracket for the knife holder. Locate the knife holder per the drawings. Attach the rack to the bracket with Component Hardware model Q37-0250 stainless steel keyhole studs welded to the bracket at the top.
- 1 ea. Component Hardware model S90-0020 drawer assembly. Locate the drawer per the drawings.
- 2 ea. Component Hardware Model R58-1010 electrical outlet box at the microwave oven. Attach the boxes to the overshelf with stainless steel fasteners per the manufacturer's requirements. Provide with stainless steel cover plates. Provide and install conduit in an unexposed manner from the box through the shelf upright to a 4x4 junction box mounted below the table top.

ITEM NO. 26 - MOBILE SERVING COUNTER (2 REQUIRED)

Custom fabricated mobile serving counter to be constructed per the drawings with a fully welded 14 gauge type 304 stainless steel top with a 2" drop down at the cashier stand. Provide 12 gauge fully welded type 304 stainless steel channel underbracing under the top with fully welded closed ends where they are exposed. Sound deadened between the top and the underbracing.

Features

- 01 Provide with a 2" turn down with a tight hem at the sides.
- 02 Provide a 16 gauge type 304 stainless steel fully welded counter body with a 16 gauge type 304 stainless steel fully welded undershelves per the drawing elevations. Provide 12 gauge type 304 stainless steel channel underbracing under the undershelves. Sound deadened between the undershelves and the underbracing. Notch the undershelf around the floor sink.
- 03 Provide a 16 gauge type 304 stainless steel double pan hinged doors per the elevations. Fully weld the corners on the panels.
- 04 Provide a 16 gauge type 304 stainless steel double pan hinged doors with fully welded louvers per the elevations. Fully weld the corners on the panels.

- 05 Provide a Component Hardware Group, Inc. model P46-1012 pull at the doors. Attach with stainless steel screws.
- 06 Provide a Component Hardware Group, Inc. model M32-2401 magnetic catches at the doors. Install the catch per the manufactures requirements.
- 07 Provide steel j-boxes on the counter body per the drawings and elevations for switches and controls. Provide with stainless steel cover plates. Weld the j-boxes to the counter.
- 08 Provide removable 18 gauge stainless steel panels on the counter fronts and side per the elevations. Provide a 6" x 6" one piece panel at the corners. Attach the panels to the counter with 14 gauge stainless steel Z-clips at the bottom of the panels.
- 09 Provide a quarter-turn ball valve drain valve in an 18 gauge fully welded stainless steel recess per the drawings. Pre-pipe the hot well drain to the valve and the drain line to the floor drain per current codes.
- 10 Provide polyurethane tired casters with brakes.

Accessories

- 2 ea. T & S model B-0208 faucet. Provide a hot water indicator on the handle.
- 2 Lot G.A. Systems Inc. sneeze guard per proposal number 1924 - Burroughs and the drawings in a brushed stainless steel finish. Provide an undercounter mount. Install into the counter top per the manufactures requirements.

ITEM NO. 27 - DROP-IN HOT FOOD WELLS (2 REQUIRED)

Low Temp Industries model TW-DW-2 with all the standard features.

Accessories

- 2 ea. 208 volts, single phase.

ITEM NO. 28 - DROP-IN HOT FOOD WELLS (2 REQUIRED)

Low Temp Industries model TW-DW-3 with all the standard features.

Accessories

- 2 ea. 208 volts, single phase.

ITEM NO. 29 - DROP-IN COLD FOOD WELLS (2 REQUIRED)

Low Temp Industries model DI-2025TA with all the standard features.

Accessories

- 2 ea. 120 volts, single phase.

ITEM NO. 30 - NUMBER NOT USED

ITEM NO. 31 - MOBILE CASHIER STAND (1 REQUIRED)

Custom fabricated mobile cashier stand to be constructed per the drawings and details with a fully welded 14 gauge type 304 stainless steel top. Provide 12 gauge fully welded type 304 stainless steel channel underbracing under the top with fully welded closed ends where they are exposed. Sound deadened between the top and the underbracing.

Features

- 01 Provide with a 2" turn down with a tight hem at the exposed sides.

- 02 Provide a 16 gauge type 304 stainless steel fully welded counter body per the drawing elevations.
- 03 Provide a 16 gauge type 304 stainless steel fully welded foot rest per the drawing elevations. Provide 12 gauge type 304 stainless steel fully welded channel underbracing under the foot rest. Sound deadened between the undershelves and the underbracing.
- 04 Provide a 16 gauge type 304 stainless steel fully welded cash drawer per the elevations. Provide a 16 gauge type 304 stainless steel fully welded drawer face. Provide Component Hardware S52 series drawer slides. Weld the slides to the drawer assembly. Provide Component Hardware model P62-1010 pulls. Weld the pulls to the drawer face from the inside of the face.
- 05 Provide removable 18 gauge stainless steel panels on the counter fronts and side per the elevations. Provide a 6" x 6" one piece panel at the corners. Attach the panels to the counter with 14 gauge stainless steel Z-clips at the bottom of the panels.
- 08 Provide polyurethane tired casters with brakes.

ITEM NO. 32 - POS SYSTEM BY THE OWNER

ITEM NO. 33 - MOBILE MILK COOLERS (2 REQUIRED)

True Mfg. model TMC-34-S-SS-HC with all the standard features.

Accessories

- 2 ea. 120 volts, single phase.
- 2 ea. Model 882506 corner bumpers.
- 2 ea. Provide with 5" polyurethane casters with brakes on all the casters.

END OF SECTION