



POCATELLO/CHUBBUCK SCHOOL DISTRICT 25
LEARNING TODAY FOR THE POSSIBILITIES OF TOMORROW

Pocatello, Idaho

SPECIFICATIONS FOR

2022 LIGHTING REPLACEMENT

Jefferson Elementary

Replacement of all classroom, gym, and exterior lighting

BIDS WITH CONDITIONS WILL NOT BE ACCEPTED

BID OPENING

**April 7, 2022
10:30 AM**



POCATELLO/CHUBBUCK SCHOOL DISTRICT 25
LEARNING TODAY FOR THE POSSIBILITIES OF TOMORROW

SCHOOL DISTRICT NO. 25
INVITATION TO BID

Sealed bids will be received by the School District 25 Business Office, Bannock County, Idaho at 3115 Pole Line Road, Pocatello, Idaho, 83201 until **10:30 AM on April 7, 2022** for the following:

2022 Light Replacement

A mandatory pre-bid conference and walk-thru to review the projects will be held at Jefferson Elementary School, 1455 Gwen Dr, Pocatello, Idaho, on **March 24, 2022 at 10:30 AM.**

Specifications and additional details, (including bid forms), may be secured at 3115 Pole Line Road, Pocatello, Idaho, 83201 and on the District website at: <https://www.sd25.us/Content/bo-bidding>

All bids must be on the forms furnished, all blank spaces filled in, and signed with the name and address of the Bidder. No unqualified bids will be read.

Each bid shall be accompanied by a certified check, cashier's check, or a bidder's bond, (executed by a qualified surety company with the power to do business in the State of Idaho) in the sum of not less than five percent (5%) of the total bid, made payable to School District No. 25, Bannock County, Pocatello, Idaho. This surety shall be forfeited by the bidder in the event of failure to enter into a contract. Personal or company checks will not be accepted. Compliance with Idaho Public Works Law is required.

The Board of Trustees reserves the right to reject any or all bids or to waive any informalities, or to accept the bid or bids deemed best for School District No. 25, Bannock County, Pocatello, Idaho.

Renae Johnson, Clerk
School District No. 25

Publish dates:

March 13, 2022
March 20, 2022

IDAHO STATE JOURNAL

INSTRUCTIONS TO BIDDERS

VENDOR RESPONSIBILITY:

Sealed bids will be received on or before the time and date set forth under Invitation to Bid.

The owner reserves the right to accept or reject any part or all bids.

Bidders submitting a bid on this work will be required to figure and furnish everything as called for by these specifications and the requirements of the bid proposal sheet.

All bids shall be in a sealed envelope addressed: Business Office, 3115 Pole Line Road, Pocatello, Idaho, 83201. The following shall be written on the exterior of the envelope:

“BID FOR JEFFERSON LIGHTING REPLACEMENT
TO BE OPENED ON April 7, 2022 at 10:30 AM”

Bids not delivered by contractors at time of bid opening must be received in mail no later than 4:00 PM on April 6, 2022, the day before the bid opening.

EXAMINATION OF THE SITE AND DOCUMENTS:

Refer all questions to Brian Glenn, Energy Manager, (208) 233-2604. Contact with other district staff, Board of Trustees, or Administration, will be by written permission only.

A **mandatory pre-bid conference** and walk-thru to review the projects will be held at Jefferson Elementary, 1455 Gwen Dr, Pocatello, Idaho, on March 24, 2022 at 10:30 AM.

Before submitting a proposal, the bidder shall:

1. Carefully examine the specifications.
2. Visit the worksite.
3. Be fully informed of existing conditions and limitations.
4. Include in the bid, sums sufficient to cover all items required by the contract, and shall rely entirely upon his own examinations in making his proposal.

INTERPRETATIONS:

Should a bidder find discrepancies in or omissions from the specifications, or be in doubt as to their meaning, he should at once notify the Owner, who will send written instructions or addenda to all bidders. The owner will not be responsible for oral interpretations. Questions received less than 48 hours before time for bid opening cannot be answered. All addenda issued during the time of bidding will be incorporated in the contract.

BID GUARANTEE:

As a guarantee that, if awarded the contract, the bidder will execute same and furnish bond. Each bid will be accompanied by a Certified check, Cashier's Check, or Bid Bond for not less than five percent (5%) of the base bid payable to the Owner. NO PERSONAL OR COMPANY CHECKS WILL BE ACCEPTED.

OBJECTIONS:

Written objections to specifications or bid procedures must be received by the clerk, secretary, or other authorized official of the District at least one (1) business day before the date and time upon which bids are scheduled to be received, per Idaho Code Section 68-2806(c).

LAWS AND ORDINANCES:

The contractor hereby binds himself to protect and save harmless the owner from all damages arising from the violation of any and all Federal, State, County, City, and all other laws, rules, regulations, in the performance of the terms of the contract.

HOLD HARMLESS AGREEMENTS:

The District expects your work to conform to professional standards. The contractor is expected to hold the District harmless for all damages or claims arising out of the work performed by the contractor. The District will not agree to hold the contractor harmless for damages or claims.

EQUIPMENT:

The contractor shall provide all labor, materials, tools, and equipment, etc. necessary for the complete and substantial execution of everything described in the specifications.

STORAGE OF MATERIALS:

The contractor shall make arrangement and coordinate with the Maintenance Department for storage of materials. Any damages of life or property caused by storage of materials on the above indicated place shall be paid for by the contractor, who shall hold the owner harmless for any damages concerning the same.

SUPERVISION:

The supervision of this work will be done by School District #25 Maintenance Department.

EVIDENCE OF QUALIFICATIONS:

Upon request of the owner, a bidder whose bid is under consideration for award of the contract shall submit, promptly, satisfactory evidence of his financial resources, his experiences, and the organization and equipment he has available for performance of the contract.

EMPLOYMENT OF RESIDENTS OF IDAHO:

In compliance with Idaho Laws, Section 44-1001 and 44-1002 Idaho Code, the contractor must employ ninety-five percent 95% bona fide Idaho residents as employees on any such contracts except where under such contracts fifty (50) or less persons are employed the contractor may employ ten percent (10%) nonresidents, provided however, in all cases such employers must give preference to the employment of bona fide Idaho residents in the performance of such work.

CONTRACTOR'S LICENSE:

In compliance with Idaho Laws, the contractor must be registered with the State of Idaho, and hold the required Public Works Contractor's License before obtaining the contract documents and before submitting a bid for this work.

INSURANCE:

All contractors who provide goods or services to the District are required to provide the District with certificates of insurance for General Liability, Auto Liability, Workers Compensation, and Professional Liability if applicable.

The General Liability and/or Professional Liability certificate must name the District as an additional insured under the contractor’s policy. Certificates are to be provided to the District prior to any work commencing on District property. This would include the placement of any equipment or materials at the work site

Minimum Insurance Limits

General Liability	\$1,000,000 per occurrence \$1,000,000 products and completed operations \$1,000,000 annual aggregate
Auto Liability	\$1,000,000 per occurrence
Worker’ Compensation	Statutory
Professional Liability	\$1,000,000 per occurrence \$1,000,000 annual aggregate

OWNER/CONTRACTOR AGREEMENT:

The Agreement for the work will be written on a District provided Form of Agreement between Owner and Contractor where the basis of payment is a stipulated sum.

PERFORMANCE BOND:

The successful bidder will be required to furnish a 100% performance bond when entering into the contract work, per Idaho Code Section 54-1926, "...conditioned upon the faithful performance of the contract in accordance with the plans, specifications and conditions thereof."

PAYMENT BOND:

The successful bidder will be required to furnish a 100% payment bond when entering into the contract work, per Idaho Code Section 54-1926, "solely for the protection of persons supplying labor or materials, or renting, leasing, or otherwise supplying equipment to the contractor or his subcontractors in the prosecution of the work provided for in such contract."

5% RETAINAGE:

The Owner will retain 5% of the Contractor's earned sum to ensure faithful performance. This 5% will be released to the Contractor upon receipt of approval from State of Idaho.

LIQUIDATED DAMAGES:

Contractor shall be required to pay Owner as liquidated damages the sum of \$500 for each day, after the scheduled completion date, that the project is unfinished.

CHANGES IN THE WORK:

The owner, without invalidating the contract, may order extra work or make changes by altering, adding to, or deducting from the work; the contract sum being adjusted accordingly. All such work shall be executed under the conditions of the original contract, except that any claim for extension of the time caused thereby shall be adjusted at the time of ordering such change.

The total allowance for combined overhead and profit for changes shall be included in the total cost to the owner and shall be based on the following schedule:

- a) For the Contractor, 10% over cost;
- b) For the Sub-Contractor, 15% over cost to be divided 10% for Sub-Contractor and 5% for Contractor; and
- c) For any Sub-Subcontractor, 15% over cost to be divided 5% for Contractor, 5% for Sub-Contractor, and 5% for Sub-Subcontractor.

FORM WH5:

Per Idaho Code Section 54-1904A, within thirty (30) days of award of bid, the contractor shall file with the State Tax Commission a form WH-5, Public Works Contract Report.

INSPECTION OF WORK:

The representative of the owner shall at all times have access to the work wherever it is in preparation or progress and the contractor shall provide facilities for such access and for inspection.

WARRANTY:

Manufacturer shall warrant products under normal use and service to be free from defects in materials and workmanship for a period of one year from date of delivery.

Warranty shall cover repair or replacement of such parts determined defective upon inspection. Warranty does not cover any product or part of a product subject to accident, negligence, alteration, abuse or misuse. Warranty does not cover any accessories or parts not supplied by the manufacturer.

Warranty shall not cover any labor expended or materials used to repair any equipment without manufacturer's prior written authorization. -

CLEAN UP:

The contractor shall at all times keep the premises free from accumulations of waste material or rubbish caused by his employees or work, and at the completion of the work he shall remove all his rubbish from and about the building and all tools and surplus materials and shall leave his work clean. In case of dispute, the owner shall remove the rubbish and surplus materials and charge the cost to the contractor.

IDAHO EMPLOYER ALCOHOL AND DRUG-FREE WORKPLACE ACT: Include with your bid sheet a contractor's affidavit pursuant to Idaho Code Section 72-1717.

BIDDER CERTIFICATION FORM: All bidders must complete and submit the Bidder Certification Form included with this bid request.

PAYMENT:

Prices must remain firm as quoted by supplier until quantity awarded is received. Application for payment dated on or before the 25th of the month, shall be paid by the 15th of the following month. Application for payment dated after the 25th of the month, shall be paid within 30 days.

Delivery may be accepted any time, however, payment for the 2022-2023 fiscal year cannot be made until after July 1, 2022 when those funds have been released.

BID:

The following universal specifications are being used as a guideline. Alternate bids for equal equipment will be considered upon District approval two weeks prior to the bid due date. Substitutions or major alternations must be indicated upon the proposal sheet at the time of the bid submission. Bids must be based upon conditions at the site and these specifications. Bids shall be submitted in accordance with the requirements shown on the bid form.

BID EVALUATION CRITERIA:

Contractor selection on this project will be evaluated based on the following:

- 1) Price
- 2) Contractor reputation for quality of work with current customers or past performance with District 25. (please list all jobs/contracts greater than \$10,000 performed in the past two years if contractor has not performed one for the District in past 5 years)
- 3) Vendor ability to best match the listed criteria as specified.

DELIVERY AND START OF WORK:

The time frame for the lighting replacement to be completed is between June 6, 2022 and August 5, 2022

REQUIREMENT FOR LIGHT FIXTURE REPLACEMENT:

SCOPE OF WORK: This work is to replace light fixtures in classrooms, multipurpose room, offices, restrooms, storage areas, and all exterior fixtures. The District will install necessary suspended ceiling t-rails and tiles to accommodate new classroom and office fixtures.

- A. Contractor is responsible for verifying existing electrical loads and notifying the District if electrical service modifications might be required. The Contractor is responsible for making all electrical connections necessary unless directed differently in individual item descriptions.
- B. Removal and disposal of all existing fixtures.
- C. All abandoned wiring associated with project is to be removed and recycled.
- D. Installation of approved fixtures as outlined in fixture replacement sheet.
- E. Installation of new low voltage control wiring for 0-10V dimming as per manufactures recommendations in classroom areas.
- F. Removal of existing wall switches and installation of new wall plates to accommodate Lutron 3 button Pico RF control in classrooms areas.
- G. Installation of Lutron Vive RF controller in classrooms areas.
- H. Installation of Lutron ceiling mount RF occupancy sensors in classrooms and office areas.
- I. Installation of Lutron Caseta RF switch in specified areas.
- H. Cost for all permits and inspections.

LIGHT FIXTURE INFORMATION - See the attached Specifications for the Controls listed

Room #	Existing Fixture	New Fixtures	New Fixture Type	Controls	Notes
1	18	8	PAN22-30WLED-U-40	Lutron Part #s RMJS-8T-DV-B PJ2-3BRL-GWH-L01 pico-wbx-adapt LRF2-OCR2B-P-WH	
2	16	8	PAN22-30WLED-U-40	Lutron Part #s RMJS-8T-DV-B PJ2-3BRL-GWH-L01 pico-wbx-adapt LRF2-OCR2B-P-WH	
3	18	8	PAN22-30WLED-U-40	Lutron Part #s RMJS-8T-DV-B PJ2-3BRL-GWH-L01 pico-wbx-adapt LRF2-OCR2B-P-WH	
4	18	8	PAN22-30WLED-U-40	Lutron Part #s RMJS-8T-DV-B PJ2-3BRL-GWH-L01 pico-wbx-adapt LRF2-OCR2B-P-WH	
5	16	8	PAN22-30WLED-U-40	Lutron Part #s RMJS-8T-DV-B PJ2-3BRL-GWH-L01 pico-wbx-adapt LRF2-OCR2B-P-WH	
6	18	8	PAN22-30WLED-U-40	Lutron Part #s RMJS-8T-DV-B PJ2-3BRL-GWH-L01 pico-wbx-adapt LRF2-OCR2B-P-WH	
7	18	8	PAN22-30WLED-U-40	Lutron Part #s RMJS-8T-DV-B PJ2-3BRL-GWH-L01 pico-wbx-adapt LRF2-OCR2B-P-WH	
8	16	8	PAN22-30WLED-U-40	Lutron Part #s RMJS-8T-DV-B PJ2-3BRL-GWH-L01 pico-wbx-adapt LRF2-OCR2B-P-WH	

9	18	8	PAN22-30WLED-U-40	Lutron Part #s RMJS-8T-DV-B PJ2-3BRL-GWH-L01 pico-wbx-adapt LRF2-OCR2B-P-WH	
10	18	8	PAN22-30WLED-U-40	Lutron Part #s RMJS-8T-DV-B PJ2-3BRL-GWH-L01 pico-wbx-adapt LRF2-OCR2B-P-WH	
11	16	8	PAN22-30WLED-U-40	Lutron Part #s RMJS-8T-DV-B PJ2-3BRL-GWH-L01 pico-wbx-adapt LRF2-OCR2B-P-WH	
12	18	8	PAN22-30WLED-U-40	Lutron Part #s RMJS-8T-DV-B PJ2-3BRL-GWH-L01 pico-wbx-adapt LRF2-OCR2B-P-WH	
13	18	8	PAN22-30WLED-U-40	Lutron Part #s RMJS-8T-DV-B PJ2-3BRL-GWH-L01 pico-wbx-adapt LRF2-OCR2B-P-WH	
14	16	8	PAN22-30WLED-U-40	Lutron Part #s RMJS-8T-DV-B PJ2-3BRL-GWH-L01 pico-wbx-adapt LRF2-OCR2B-P-WH	
15	18	8	PAN22-30WLED-U-40	Lutron Part #s RMJS-8T-DV-B PJ2-3BRL-GWH-L01 pico-wbx-adapt LRF2-OCR2B-P-WH	
16	18	8	PAN22-30WLED-U-40	Lutron Part #s RMJS-8T-DV-B PJ2-3BRL-GWH-L01 pico-wbx-adapt LRF2-OCR2B-P-WH	
17	16	8	PAN22-30WLED-U-40	Lutron Part #s RMJS-8T-DV-B PJ2-3BRL-GWH-L01 pico-wbx-adapt LRF2-OCR2B-P-WH	

18	18	8	PAN22-30WLED-U-40	Lutron Part #s RMJS-8T-DV-B PJ2-3BRL-GWH-L01 pico-wbx-adapt LRF2-OCR2B-P-WH	
19	20	8	PAN22-30WLED-U-40	Lutron Part #s RMJS-8T-DV-B PJ2-3BRL-GWH-L01 pico-wbx-adapt LRF2-OCR2B-P-WH	
19a	1	1	PAN22-20WLED-U-40	N/A	
20	20	8	PAN22-30WLED-U-40	Lutron Part #s RMJS-8T-DV-B PJ2-3BRL-GWH-L01 pico-wbx-adapt LRF2-OCR2B-P-WH	
20a	1	1	PAN14-20WLED-U-40	N/A	
21	12	6	PAN22-30WLED-U-40	Lutron Part #s RMJS-8T-DV-B PJ2-3BRL-GWH-L01 pico-wbx-adapt LRF2-OCR2B-P-WH	
22	12	6	PAN22-30WLED-U-40	Lutron Part #s RMJS-8T-DV-B PJ2-3BRL-GWH-L01 pico-wbx-adapt LRF2-OCR2B-P-WH	
23	12	6	PAN22-30WLED-U-40	Lutron Part #s RMJS-8T-DV-B PJ2-3BRL-GWH-L01 pico-wbx-adapt LRF2-OCR2B-P-WH	
Media CTR 24	20	0	N/A	N/A	These fixtures are being removed
25	3	3	PAN22-30WLED-U-40	Lutron Part #s RMJS-8T-DV-B PJ2-3BRL-GWH-L01 pico-wbx-adapt LRF2-OCR2B-P-WH	
25a	1	1	PAN14-20WLED-U-40	N/A	
26	6	4	PAN22-30WLED-U-40	Lutron Part #s RMJS-8T-DV-B PJ2-3BRL-GWH-L01 pico-wbx-adapt LRF2-OCR2B-P-WH	
Gym 27	24	24	PAN24-60WLED-U-40	N/A	Need surface mount kits.

Boiler Rm 27a	3	3	VS4-25WLED-U-40-FRAL	N/A	
Stage 28	4	4	PAN22-20WLED-U-40	N/A	
Kitchen	3	3	PAN14-20WLED-U-40	N/A	Need surface mount kits.
30	2	2	PAN22-30WLED-U-40	Lutron Part #s RMJS-8T-DV-B PJ2-3BRL-GWH-L01 pico-wbx-adapt LRF2-OCR2B-P-WH	
31	2	2	PAN22-30WLED-U-40	Lutron Part #s RMJS-8T-DV-B PJ2-3BRL-GWH-L01 pico-wbx-adapt LRF2-OCR2B-P-WH	
32	2	2	PAN22-30WLED-U-40	Lutron Part #s RMJS-8T-DV-B PJ2-3BRL-GWH-L01 pico-wbx-adapt LRF2-OCR2B-P-WH	
33	2	2	PAN22-30WLED-U-40	Lutron Part #s RMJS-8T-DV-B PJ2-3BRL-GWH-L01 pico-wbx-adapt LRF2-OCR2B-P-WH	
34	3	2	PAN22-30WLED-U-40	Lutron Part #s RMJS-8T-DV-B PJ2-3BRL-GWH-L01 pico-wbx-adapt LRF2-OCR2B-P-WH	
35	3	2	PAN22-30WLED-U-40	Lutron Part #s RMJS-8T-DV-B PJ2-3BRL-GWH-L01 pico-wbx-adapt LRF2-OCR2B-P-WH	
36	2		PAN22-20WLED-U-40	N/A	
Mens RR 37	1	1	VS4-25WLED-U-40-FRAL	N/A	
Womens RR 38	1	1	VS4-25WLED-U-40-FRAL	N/A	
Boys RR 39	2	2	VS4-25WLED-U-40-FRAL	N/A	
Girls RR 40	3	3	VS4-25WLED-U-40-FRAL	N/A	
41	1	1	VS4-25WLED-U-40-FRAL	N/A	
42	2	2	VS4-25WLED-U-40-FRAL	N/A	
Boys RR 43	3	3	VS4-25WLED-U-40-FRAL	N/A	

Girls RR 44	3	3	VS4-25WLED-U-40-FRAL	N/A	
Exterior Wall Packs	2	2	WMPO-70-UNIV-40	N/A	
Exterior Eve Fixtures	29	29	UFO-28WLED-UNIV-40-WHT	N/A	

BID SHEET
2022 LIGHTING REPLACEMENT

Date: _____

Board of Trustees
School District No. 25
3115 Pole Line Road
Pocatello, ID 83201

We, the undersigned, propose to furnish all labor, materials, tools, and equipment and complete all work called for by these specifications in connection with Jefferson Lighting Replacement, under the supervision of the School Plant Coordinator and the Director of Business Operations, for the sum of:

PROJECT

AMOUNT

Jefferson Lighting Replacement. \$ _____

We further acknowledge Addendum(s) received. No. _____, dated _____.

Work can begin June 6, 2022 and must be completed by August 5, 2022.

The Board of Trustees reserves the right to reject any/or all bids or to waive any informalities, or to accept the bid or bids deemed best for School District No. 25, Bannock County, Pocatello, Idaho.

Respectfully submitted,

- Attached, if applicable, is a listing of subcontractors names and addresses for this project.
- Attached is our Affidavit of Alcohol and Drug-Free Worksite, as pursuant to Idaho Code 72-1717.
- Attached is Bidder Certification Form.

Company Name

Authorized Signature / Date

Address

Title

City, State, Zip

Public Works License Number

Phone / Fax Number

Worker's Comp & Liability Insurance Exp. Date

Email if applicable

CONTRACTOR'S AFFIDAVIT
CONCERNING ALCOHOL AND DRUG-FREE WORKPLACE

STATE OF _____

COUNTY OF _____

Pursuant to the Idaho Code, Section 72-1717, I, the undersigned, being duly sworn, depose and certify that named contractor is in compliance with the provisions of Idaho Code section 72-1717; that named contractor provides a drug-free workplace program that complies with the provisions of Idaho Code, title 72, chapter 17 and will maintain such program throughout the life of a state construction contract and that named contractor shall subcontract work only to subcontractors meeting the requirements of Idaho Code, section 72-1717(1)(a).

Name of Contractor

Address

City and State

By: _____
(Signature)

Subscribed and sworn to before me this _____ day of _____, 2022.

Commission expires:

NOTARY PUBLIC, residing at



BIDDER CERTIFICATION FORM

- 1. Debarment and Suspension - In submitting this bid proposal, we hereby certify that we have not been suspended or in any way excluded from Federal procurement actions by any Federal Agency.
2. Anti-Collusion - In submitting this bid proposal, we hereby certify this proposal was developed and prepared without any collusion with any competing bidder or District employee.
3. Anti-Lobbying - In submitting this bid proposal, we hereby certify that to the best of our knowledge and belief, no appropriated Federal funds have been paid or will be paid by or on behalf of person associated with this proposal to any person for influencing or attempting to influence and officer or employee of any agency, a member of Congress, an office or employee of Congress or an employee of a member of Congress in connection with the awarding of any Federal contract, the making of any Federal grant, the making of any Federal loan, the entering into of any cooperative agreement and the extension, continuation, renewal, amendment or modification of any Federal contract, grant, loan or cooperative agreement.
4. National Sexual Offender Registry - In submitting this bid proposal, you certify to the District that your company will prohibit any persons in your employ who are registered or required to register under the Idaho Sex Offender Registration Act from participation in company business with the District if such participation would require them to be present on school property. You certify further that you have cross checked such employees against the National Sex Offender Registry found at the following web link: http://www.nsopr.gov/

Signed: _____ Date: _____

Name & Title: _____

Company: _____ Phone: _____

Address: _____

City/State/Zip: _____

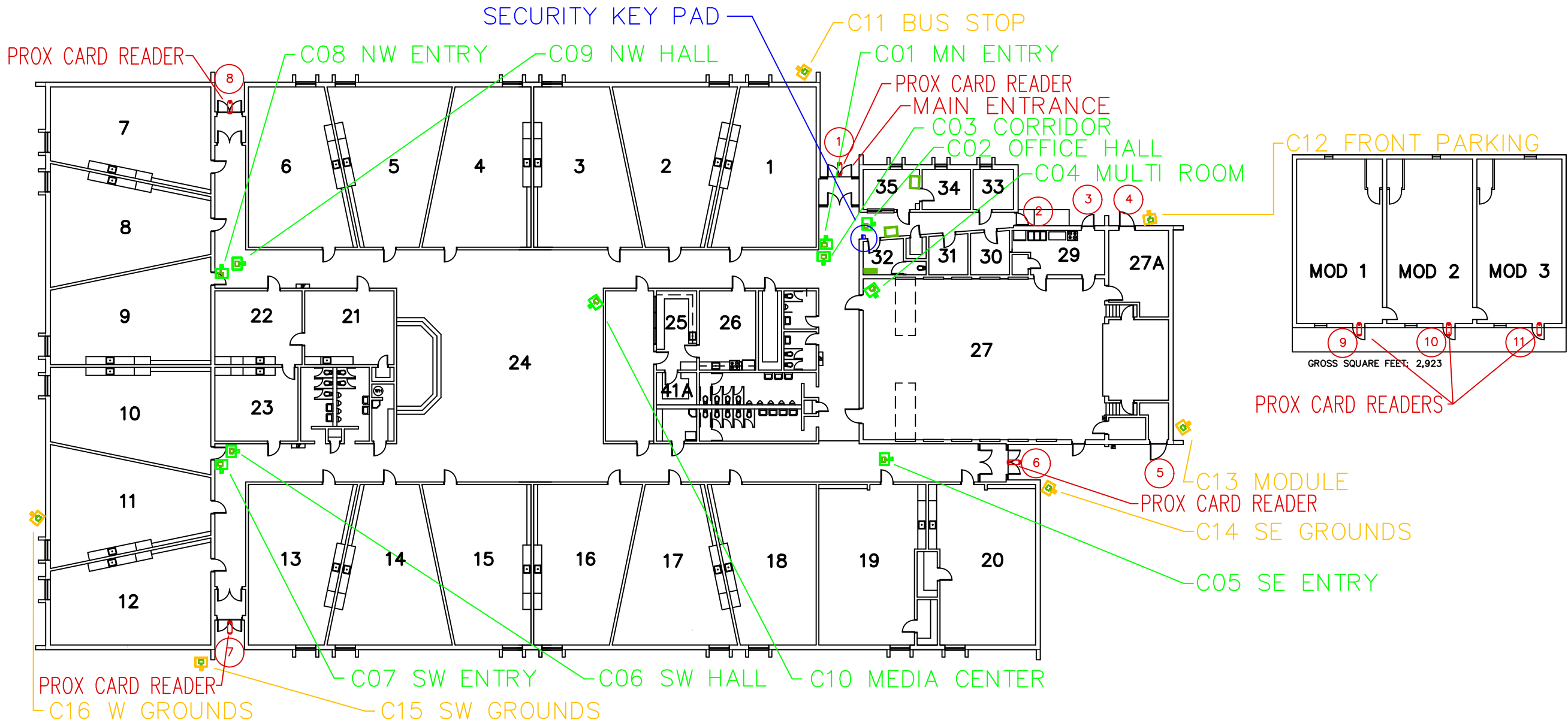

JEFFERSON ELEMENTARY SCHOOL
SCHOOL DISTRICT 25



MAIN FLOOR PLAN

SCALE: 1/16" = 1'-0"

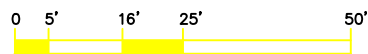

CCTV / ALARM	LEGEND
CAMERA	ROOM NAME
HEAD END EQUIPMENT	DISTRICT ROOM NUMBER
MONITOR	SCHOOL ROOM NUMBER
SECURITY SYSTEM KEY PAD	ROOM/ AREA SQUARE FOOTAGE
PROX CARD READER	DOOR #



PAN

EDGE-LIT FLAT PANEL



PAN

EDGE-LIT FLAT PANEL

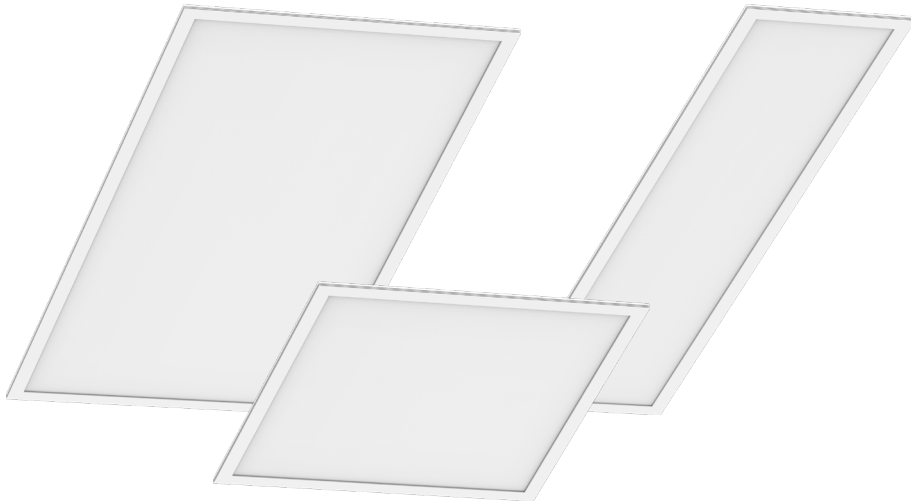

Highly Efficient, Versatile, Dependable

PAN offers a sleek, modern, low profile design with a seamless frame providing a polished appearance. Utilizing an edge-lit technology, PAN gives edge to edge illumination and a soothing appeal. With an exceptional efficacy, long lifetime rating and variety of mounting options, PAN is designed to meet the application requirements.

Features

- High efficacy – Up to 130 lm/W
- 1x4, 2x2, 2x4 sizes
- 2,400–7,500 lumen packages
- 3500K & 4000K CCT
- L90 = 50,000 hrs, L80 = 100,000 hrs
- 3x life of most competition
- Impact & Scratch Resistant Frosted Lens
- PMMA LGP Material—Non-Yellowing Lens
- 0-10V Dimmable Driver (100%–10%)
- Universal Driver (120-277V)
- IC Rated for insulated ceilings
- UL Listed for dry/damp location

Suitable Applications

- Education
- Commercial Offices
- Convenience Store
- Food Prep & Storage
- Healthcare
- Retail
- Commercial Kitchen

NSF Listed

PAN offers an NSF Listed option ideal for food prep, storage, and commercial kitchens for use in non-splash zone applications. This option ensures the highest lighting safety standards are met when required most, protecting the health and safety of end users.

No Yellowing or Cracking of the Lens

Typically offered by competing manufacturers, MS and PS lens material tends to crack and yellow after 500 hours of operation. ILP's PAN series is built to last, utilizing a high quality PMMA light guide plate and lens to resist yellowing and cracking over the life of the product.



Competition

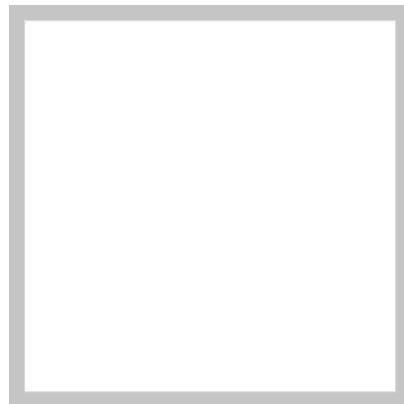

ILP's PAN

Options

- Factory Installed Whips
- Factory Installed Battery Backups
 - 5W – 12W
 - CEC Title 20 Compliant Options

Controls Ready Options

- BLD Bi-level Dimming Module
- DR DALI Ready Module
- SR Sensor Ready Module

Advanced Grouping Controls Partners



Mounting Options

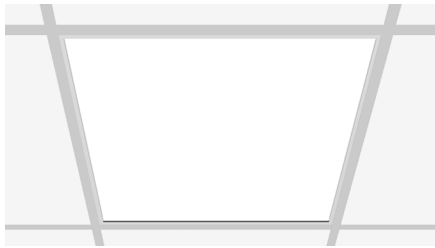

Grid Recessed



Flange Kit Mount



Skylight Mount

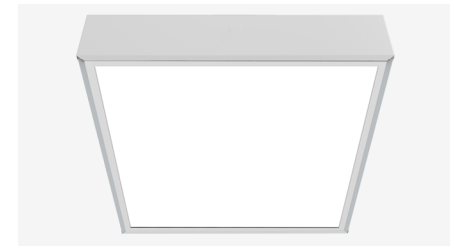

Surface Mount

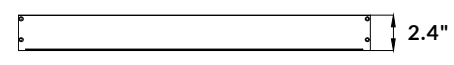

LED SYSTEMS INFO ¹	3500K		4000K		Watts ²	DLC Listing	Ambient Temp Range	Replaces
	Lumens	Efficacy	Lumens	Efficacy				
PAN14-20WLED	2,389 lm	127 lm/W	2,419 lm	128 lm/W	19W	Premium	-4°F - 104°F	2T8
PAN14-30WLED	3,842 lm	126 lm/W	3,894 lm	126 lm/W	31W	Premium	-4°F - 104°F	2T8
PAN22-20WLED	2,617 lm	128 lm/W	2,619 lm	128 lm/W	21W	Premium	-4°F - 104°F	2T8
PAN22-30WLED	3,915 lm	127 lm/W	3,941 lm	127 lm/W	31W	Premium	-4°F - 104°F	3T8
PAN24-30WLED	3,997 lm	126 lm/W	3,999 lm	127 lm/W	32W	Premium	-4°F - 104°F	2T8
PAN24-36WLED	4,519 lm	126 lm/W	4,553 lm	127 lm/W	36W	Premium	-4°F - 104°F	3T8
PAN24-50WLED	6,026 lm	125 lm/W	6,051 lm	126 lm/W	50W	Premium	-4°F - 95°F	4T8
PAN24-60WLED	7,268 lm	130 lm/W	7,491 lm	132 lm/W	60W	Premium	-4°F - 95°F	5T8

¹Values are nominal, see IES file for more detail

²Electrical data at 25C (77F). Actual wattage may differ by +/-10%.

PAN

EDGE-LIT FLAT PANEL



407-478-3759
WWW.ILP-INC.COM

An ILLUMUS Brand

Caséta® Wireless In-Wall Switch

The Caséta® Wireless In-Wall Switch provides switching of multiple load types and, when paired with Pico® remote controls, allows wireless control from anywhere in the space.

The Caséta® Wireless In-Wall Switch uses Lutron® patented Clear Connect® RF Technology which enables wireless communication with Pico® remote controls and the Lutron® Smart Bridge and Smart Bridge PRO.

Caséta® Wireless In-Wall Switch

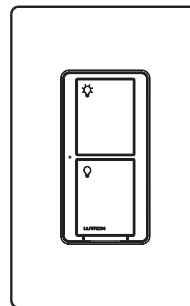

Pico® Remote Control

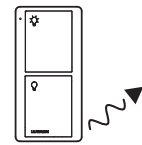

Lutron® Smart Bridge and Smart Bridge PRO

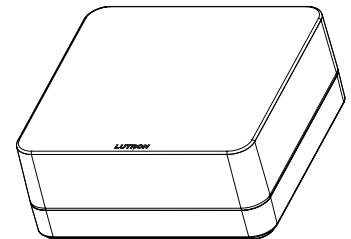

Feature	PD-5WS-DV	PD-6ANS
Works with Pico® remote controls	√	√
Works with the Lutron® App (via a Smart Bridge or Smart Bridge PRO)*	√	√
Lutron® patented Clear Connect® RF Technology works through walls and floors	√	√
Includes Front Accessible Service Switch (FASS™) for safe lamp replacement	√	√
Works with Lutron® Radio Powr Savr™ Occupancy and Vacancy Sensors in standalone applications (sensors do not work with Smart Bridge or Smart Bridge PRO)	√	√
Dual voltage (120 V~ and 277 V~)	√	
Simple two-wire installation (no neutral wire required)	√	
Installation requires neutral wire		√
May need LUT-MLC for load compatibility	√	
Switching capacity	5 A	6 A
Best load type compatibility (no LUT-MLC required)		√
Low minimum load requirement		√

* The Lutron® App is required for setup and use with the Smart Bridge and Smart Bridge PRO. The Lutron® App is compatible with iOS® devices version 6.0 or later and Android™ devices 4.0 or later. iOS is a registered trademark of Cisco in the U.S. and other countries and is used under license. Android is a trademark of Google Inc.

Job Name:	Model Numbers:
Job Number:	

Load Type and Capacity

Model Number	Description	Voltage	Load Type	Minimum Load	Maximum Load ⁴		
					Not Ganged	End of Gang	Middle of Gang
PD-5WS-DV-XX ^{1, 2}	Two-wire switch	120 V~	Incandescent/ Halogen	25 W	600 W	450 W	350 W
		277 V~	Incandescent/ Halogen	25 W	1350 W	1100 W	800 W
		120 V~	MLV	25 W	600 VA/475 W	450 VA/350 W	350 VA/275 W
		277 V~	MLV	25 W	1350 VA/1075 W	1100 VA/875 W	800 VA/625 W
		120 V~	General Purpose Fan	0.4 A	3 A	3 A	3 A
		120/277 V~	LED	Use LUT-MLC ³	5 A	4 A	3 A
		120/277 V~	Fluorescent	Use LUT-MLC ³	5 A	4 A	3 A
		120 V~	ELV	Use LUT-MLC ³	600 W	450 W	350 W
PD-6ANS-XX ^{2, 5}	Neutral-wire switch	120 V~	Incandescent/ Halogen	10 W	720 W	720 W	600 W
			MLV	10 W	720 VA	720 VA	600 VA
			Fan	0.1 A	3.6 A	3.6 A	3.6 A
			LED	1 bulb	6 A	6 A	5 A
			Fluorescent	1 ballast	6 A	6 A	5 A
			ELV	10 W	720 VA	720 VA	600 VA

¹ No Neutral Required.

² "XX" in the model number represents color/finish code.

³ To ensure proper operation of the switch with LED, fluorescent, and ELV loads, a LUT-MLC may be required, especially at lower wattages. If the status LED on the switch is flashing or solid red in color, a LUT-MLC must be installed. To guarantee best performance, installing a LUT-MLC with these load types regardless of wattage is recommended. Rarely, some load types may still flicker or glow in the off state even with the LUT-MLC installed, in which case a different load may be required.

⁴ See "Ganging and Derating" section.

⁵ Neutral required.

Job Name:	Model Numbers:
Job Number:	

Specifications

Regulatory Approvals

- cULus Listed
- NOM Certified
- FCC Approved. Complies with the limits for a Class B digital device, pursuant to Part 15 of the FCC Rules
- Industry Canada Certified
- IFTEL Certified
- NEMA 410

Power

Operating voltage:

- PD-5WS-DV: 120/277 V \sim 50/60 Hz
- PD-6ANS: 120 V \sim 50/60 Hz

Key Design Features

- Tested to withstand electrostatic discharge without damage or memory loss, in accordance with IEC 61000-4-2.
- Tested to withstand surge voltages without damage or loss of operation, in accordance with IEEE C62.41-1991 Recommended Practice on Surge Voltages in Low-Voltage AC Power Circuits.
- Switches always operate locally and do not require system control.
- Power failure memory: should power be interrupted, the control will return to its previously set level prior to the interruption when power is restored.
- Uses conventional 3-way wiring.
- Uses Lutron® Claro® wallplates or designer-style wallplates from other manufacturers. Wallplates are sold separately.
- Lutron® Claro® wallplates snap on with no visible means of attachment.
- Requires a 1-gang U.S. wallbox. 3½ in (89 mm) depth recommended, 2¼ in (57 mm) depth minimum.
- Green status LED.

System Communications and Capacity

- The Caséta® Wireless In-Wall Switch communicates with Pico® remote controls and the Lutron® Smart Bridge/Smart Bridge PRO through radio frequency (RF).
- The Caséta® Wireless In-Wall Switch communicates with Lutron® Radio Powr Savr™ Occupancy and Vacancy Sensors in a standalone application. Sensors do not work with Smart Bridge or Smart Bridge PRO.
- The Caséta® Wireless In-Wall Switch must be located within 60 ft (18 m) line-of-sight or 30 ft (9 m) through walls, of Pico® remote controls and Lutron® Smart Bridge devices.

Device limits

- Pico® remote controls and Radio Powr Savr™ occupancy sensors: up to 10 devices (total) may be paired to each Caséta® Wireless In-Wall Switch (with no Smart Bridge installed)
- Smart Bridge or Smart Bridge PRO system: up to 50 total wireless devices (Caséta® Wireless dimmers/switches, Pico® remote controls) are supported per system. Smart Bridge or Smart Bridge PRO counts as one device.

Environment

- Ambient operating temperature: 32 °F to 104 °F (0 °C to 40 °C), 0%–90% humidity, non-condensing. Indoor use only.

<p>Job Name:</p> <p>Job Number:</p>	<p>Model Numbers:</p>
--	------------------------------

Operation

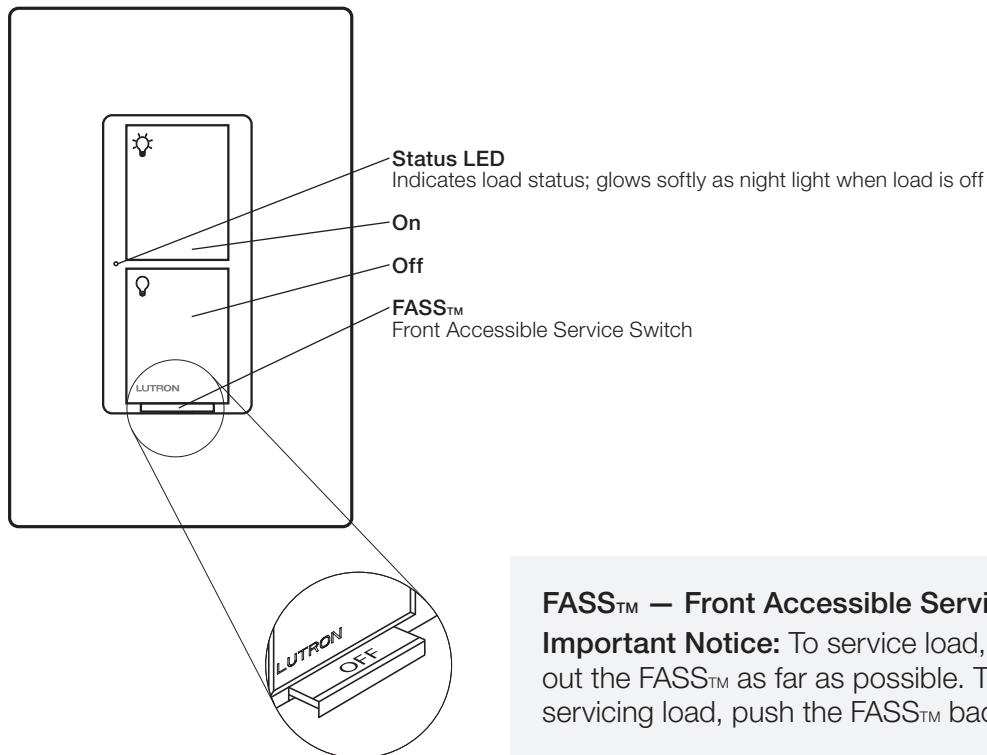

Mounting

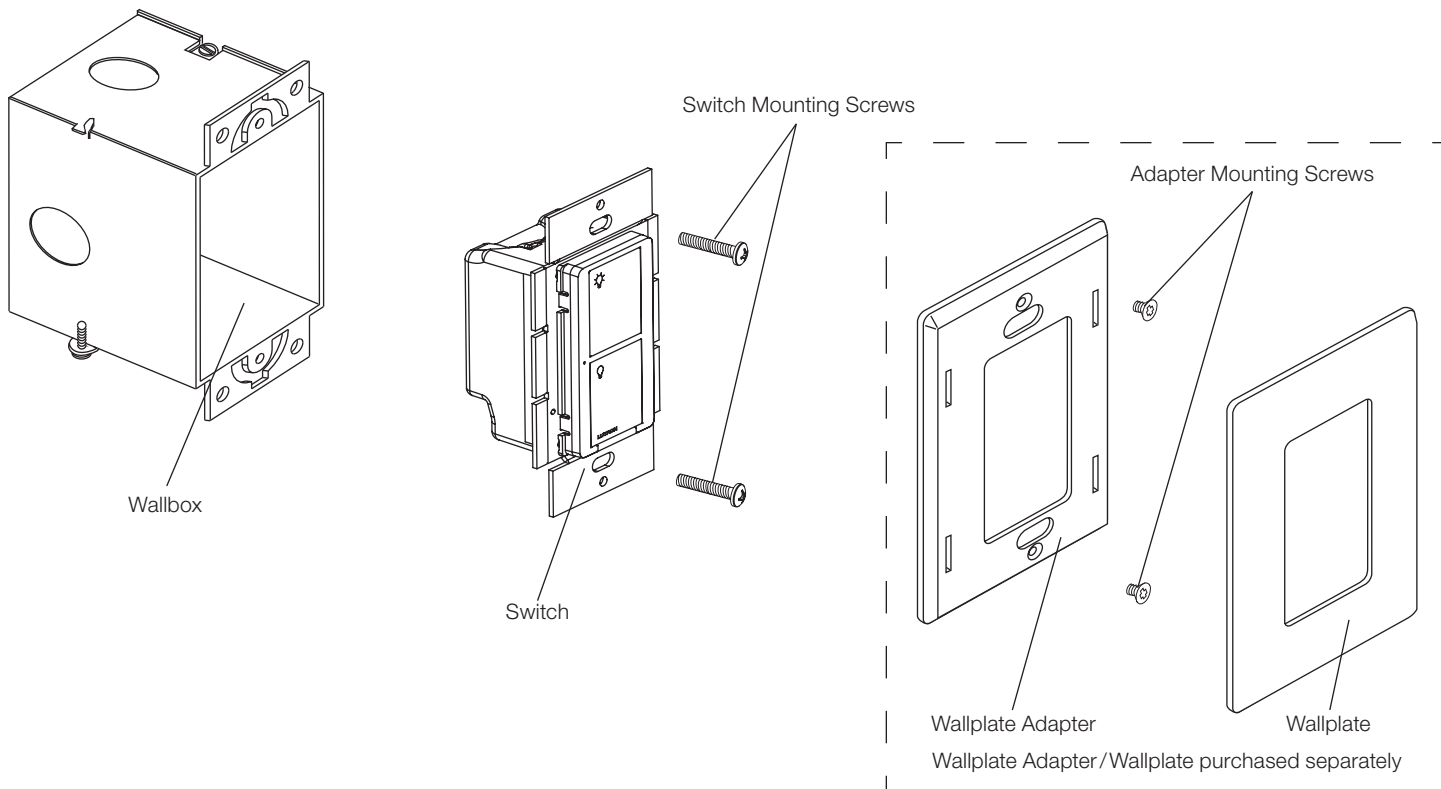

Job Name:	Model Numbers:
Job Number:	

Dimensions

Front View

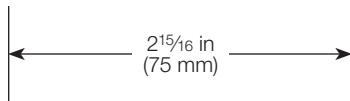
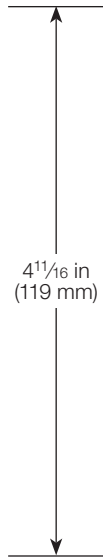
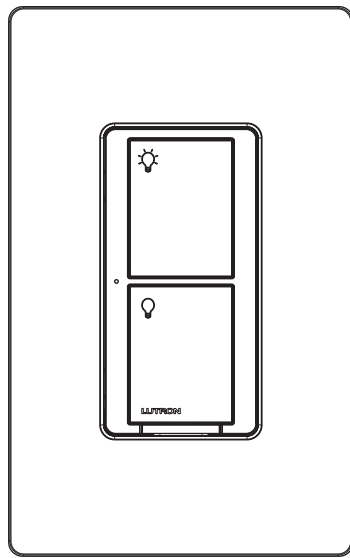

Side View

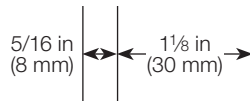
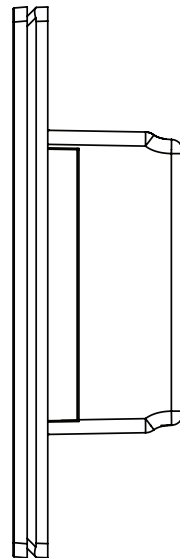

Ganging and Derating

When ganging with other switches in the same wallbox, derating is required. See “Load Type and Capacity” chart.

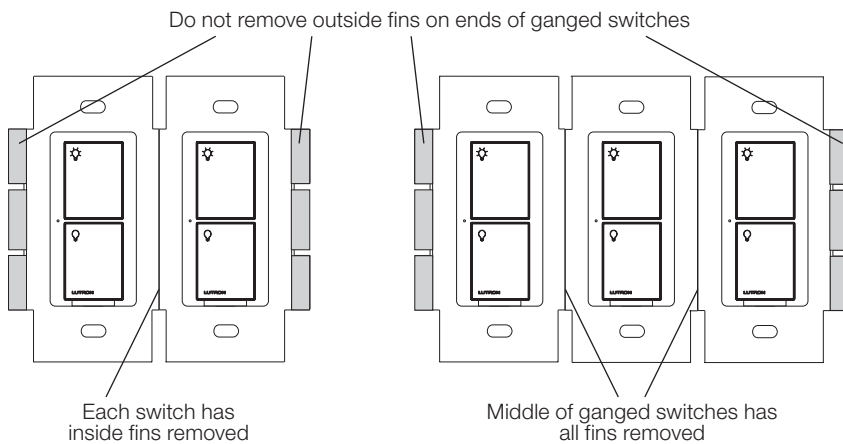

Job Name:	Model Numbers:
Job Number:	

Wiring Diagrams

Single Location Installation

PD-5WS-DV

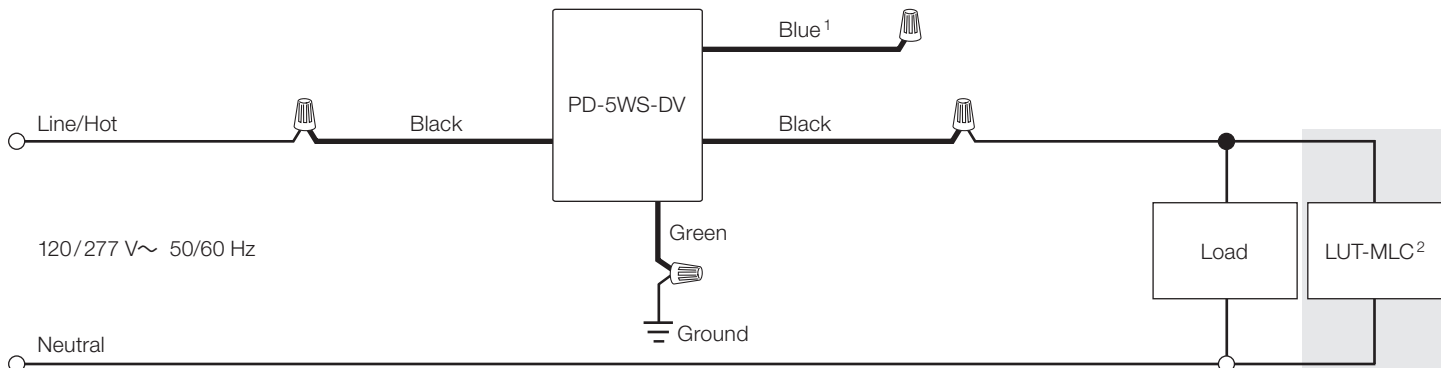

PD-6ANS

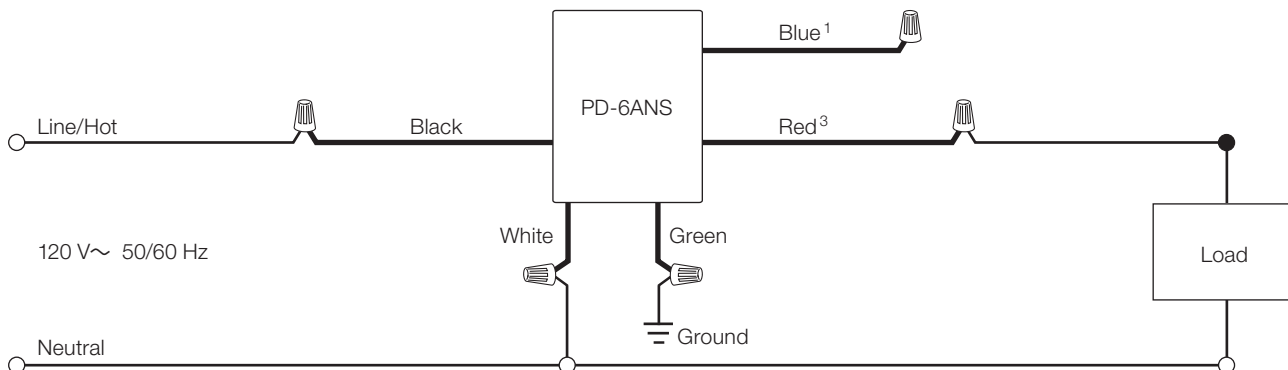

- ¹ When using controls without a mechanical 3-way switch, cap the blue terminal. **Do not** connect the blue wire to any other wiring or to ground.
- ² A LUT-MLC ensures proper function when LED, fluorescent, or ELV loads are used. Install the LUT-MLC inside a load fixture or in a separate junction box within the circuit.
- ³ The red wire must be connected to the load and the black wire must be connected to Line/Hot. The switch will not work if the wires are reversed.

(continued on next page...)

Job Name:	Model Numbers:
Job Number:	

Wiring Diagrams (continued)

3-Way Installation

Option 1: With mechanical switch

PD-5WS-DV

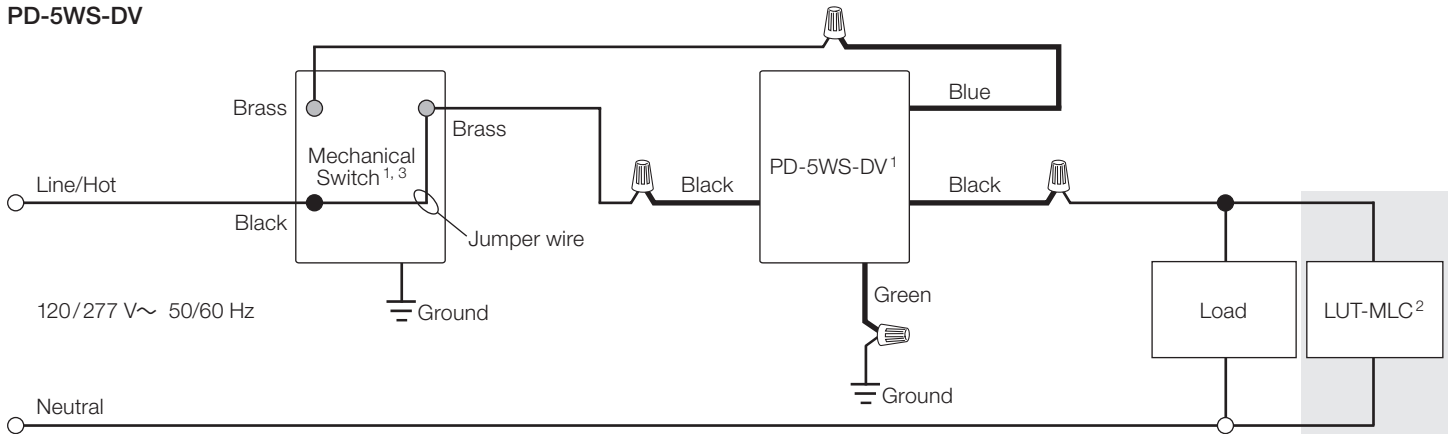

PD-6ANS (Load-side)

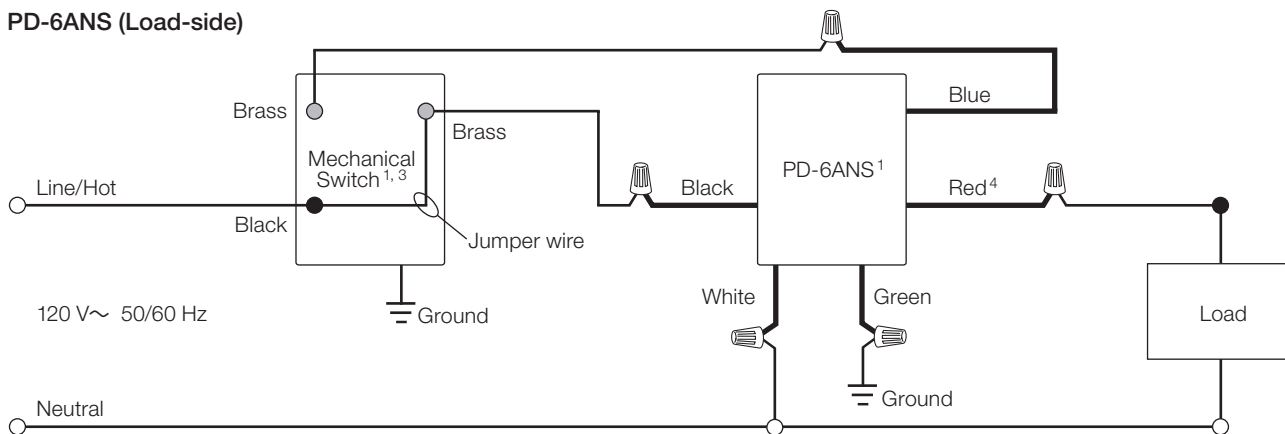

PD-6ANS (Line-side)

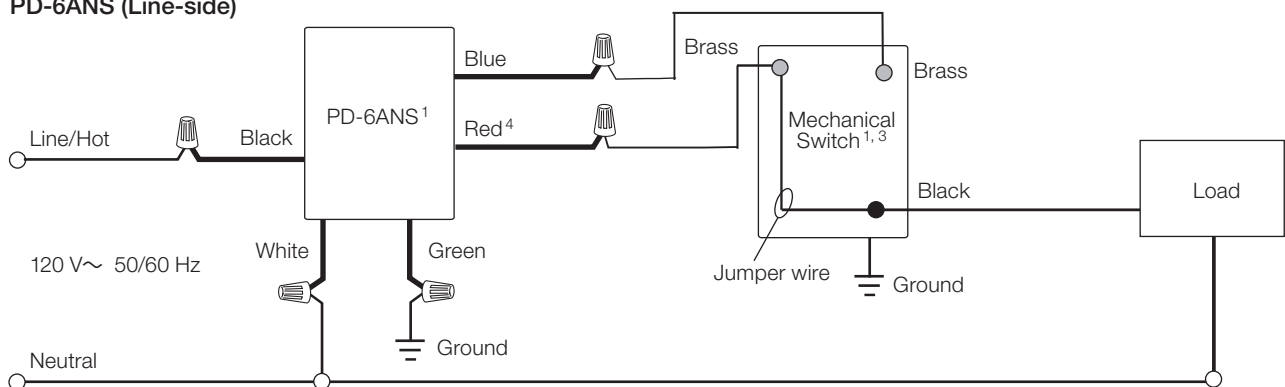

1 Location of Caséta® Wireless In-Wall Switch and mechanical switch may be reversed.

2 A LUT-MLC ensures proper function when LED, fluorescent, or ELV loads are used. Install the LUT-MLC inside a load fixture or in a separate junction box within the circuit.

3 A second location requires rewiring.

4 The red wire must be connected to the load and the black wire must be connected to Line/Hot. The switch will not work if the wires are reversed.

(continued on next page...)

<p>Job Name:</p>	<p>Model Numbers:</p>
<p>Job Number:</p>	

Wiring Diagrams (continued)

3-Way Installation

Option 2: With Pico® remote controls (PJ2-2B-xx) and wallbox mounting adapters (PICO-WBX-ADAPT)

PD-5WS-DV

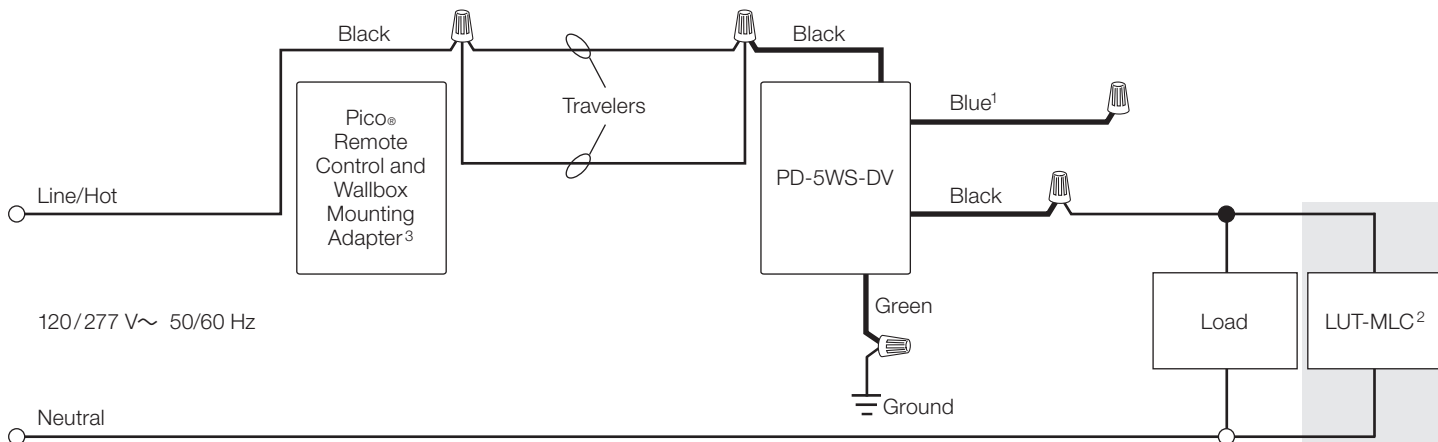

PD-6ANS

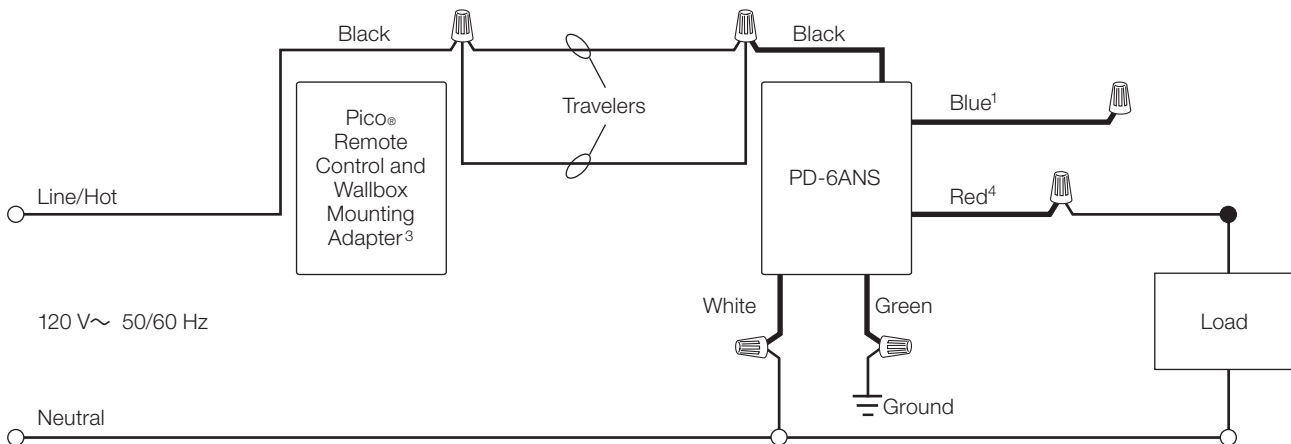

- ¹ When using controls without mechanical 3-way switch, cap the blue terminal. **Do not** connect the blue wire to any other wiring or to ground.
- ² A LUT-MLC ensures proper function when LED, fluorescent, or ELV loads are used. Install the LUT-MLC inside a load fixture or in a separate junction box within the circuit.
- ³ A second location requires rewiring.
- ⁴ The red wire must be connected to the load and the black wire must be connected to Line/Hot. The switch will not work if the wires are reversed.

(continued on next page...)

Job Name:	Model Numbers:
Job Number:	

Wiring Diagrams (continued)

Multi-location Installation (for installations where 3 or more switches control the load)
 With Pico® remote controls (PJ2-2B-xx) and wallbox mounting adapters (PICO-WBX-ADAPT)

PD-5WS-DV

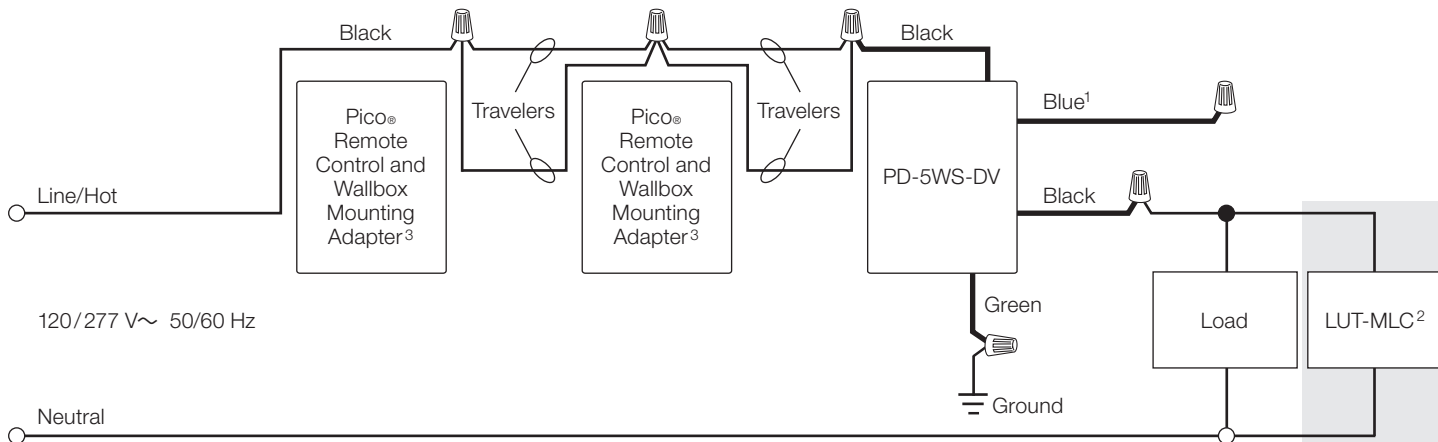

PD-6ANS

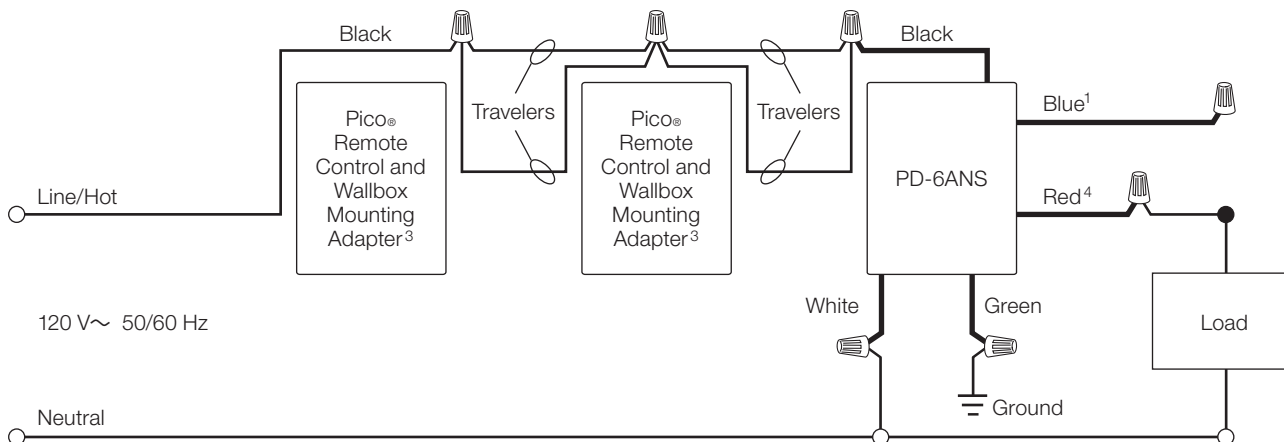

- ¹ When using controls without mechanical 3-way switch, cap the blue terminal. **Do not** connect the blue wire to any other wiring or to ground.
- ² A LUT-MLC ensures proper function when LED, fluorescent, or ELV loads are used. Install the LUT-MLC inside a load fixture or in a separate junction box within the circuit.
- ³ Each location requires rewiring.
- ⁴ The red wire must be connected to the load and the black wire must be connected to Line/Hot. The switch will not work if the wires are reversed.

Job Name:	Model Numbers:
Job Number:	

Colors and Finishes

Gloss Finishes

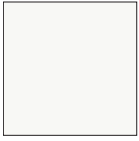

White
WH



Black
BL



Ivory
IV



Light Almond
LA

Due to printing limitations, colors and finishes shown cannot be guaranteed to perfectly match actual product colors.

Job Name: Job Number:	Model Numbers:
------------------------------	----------------

Project Name:

Part Number:

Type:



VS Value Strip



407-478-3759
www.ilp-inc.com

FEATURES

- Architectural design LED Strip fixture
- Steel housing with white powdercoat finish
- 2ft, 4ft & 8ft lengths available
- Multiple dimming & sensor options to fully control occupied & unoccupied light levels
- Round frosted acrylic lens
- Ceiling, wall, or suspension mounting options
- Junction box cover included
- 3500K, 4000K & 5000K CCT
- >80 Color Rendering Index (CRI)
- Calculated L70 > 100,000 hrs
- 0-10V Dimmable Driver (100%-10%)
- 120-277V Universal Voltage
- -4°F to 122°F Ambient Temperature Range
- 5 Year Warranty
- UL Listed for Damp Location
- DesignLights Consortium® Premium Qualified Luminaire

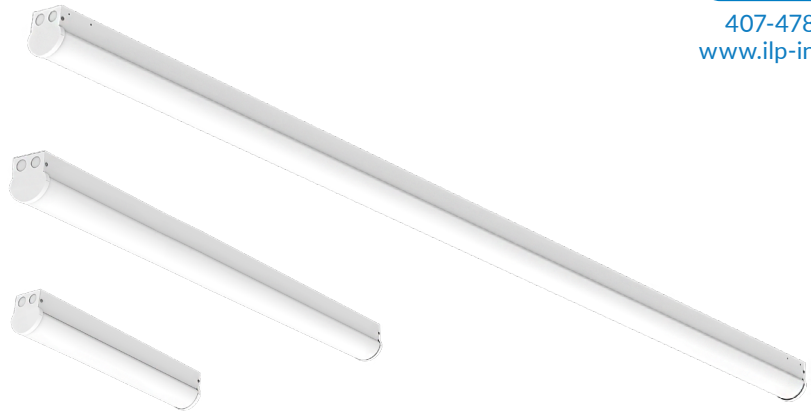

SUITABLE APPLICATIONS

- Education
- Healthcare
- Commercial Office
- Storage Facility
- Grocery Store
- Residential
- Industrial

ORDERING GUIDE:

SERIES	WATTS	DRIVER	CCT	LENS
VS2 Value Strip 2ft	20WLED	U 120-277V	50 40 35	<input checked="" type="checkbox"/> FRAL Frosted Acrylic Lens
VS4 Value Strip 4ft	25WLED 35WLED 46WLED			
VS8 Value Strip 8ft	46WLED 65WLED 90WLED			

OPTIONS		CONTROLS OPTIONS	
Factory Installed		Basic	
SD347 ^{1,2}	347V Step Down Transformer	FIOS ³	On/Off Occupancy Sensor
SD480 ^{1,2}	480V Step Down Transformer	USB ³	User Selectable Bi-Level Dim Sensor
FI/ILBCP07 ²	Factory Installed 7W LED Battery Backup	BDxx ³	Preset Bi-Level Dim Sensor (xx=%eg.20,30)
FI/ILBCP07/HE ^{2,8}	Factory Installed 7W LED Battery Backup	BDxxPC ³	Preset Bi-Level Dim Sensor w/ Photocell
FI/ILBCP10 ²	Factory Installed 10W LED Battery Backup	DHPC ³	Daylight Harvesting
FI/ILBCP10/HE ^{2,8}	Factory Installed 10W LED Battery Backup		
EM10 ¹⁰	Factory Installed 10W LED Battery Backup		
CORDx	Cord (x = ft)		
CORD/6FT/4WIRE ⁹	6ft 4 wire cord with 3 leads to power, 1 lead to battery backup		
CORD/6FT/5WIRE	6ft 5 Wire cord with 3 leads to power and 2 leads to dimming		
CORD/6FT/6WIRE	6ft 6 Wire cord with 3 leads to power, 2 leads to dimming and 1 lead to battery backup		
CORD/6F/L7-15P	Cord 6ft with 277V Twist Lock Plug		
RACEWAY/3WIRE ⁹	3 wire raceway harness for continuous wiring through fixture		
RACEWAY/5WIRE	5 wire raceway harness for continuous wiring through fixture, with dimming leads attached		
Ship With Accessories			
FMB ^{4,6}	Fixture Mounting Box		
HUB 3/4 ^{5,6}	¾" Conduit Hub		
HB-XX-18Y-PAD	Y-Toggle Hanging Cable System (xx = in)		
ALBR ⁷	Alignment Bracket		
WC ¹	Wire Cage		

¹ Does not qualify for DLC
² Not available on VS2

³ End Fixture Mounted
⁴ Use with HUB for single point mounting

⁵ Must be used with FMB
⁶ One per 4ft section

⁷ Used to align fixtures mounted in continuous rows
⁸ CEC Title 20 Compliant

⁹ Non-dimming function
¹⁰ Available with VS2 only

VS

Value Strip

QUICK SHIP ITEMS:

SERIES	WATTS	DRIVER	CCT	LENS
VS2 Value Strip 2ft	20WLED	U 120-277V	50 40 35	<input checked="" type="checkbox"/> FRAL Frosted Acrylic Lens
VS4 Value Strip 4ft	25WLED 35WLED 46WLED			
VS8 Value Strip 8ft	46WLED 65WLED 90WLED			

LED SYSTEMS INFORMATION ¹	3500K		4000K		5000K		Watts ²	CRI	DLC Listing	Replaces
	Part Numbers	Lumens	Efficacy	Lumens	Efficacy	Lumens				
VS2-20WLED-U-XX-FRAL	2,580 lm	129 lm/W	2,600 lm	130 lm/W	2,620 lm	131 lm/W	20 W	>80	Premium	1T8
VS4-25WLED-U-XX-FRAL	3,232 lm	132 lm/W	3,325 lm	133 lm/W	3,350 lm	134 lm/W	25 W	>80	Premium	2T8
VS4-35WLED-U-XX-FRAL	4,405 lm	129 lm/W	4,620 lm	132 lm/W	4,690 lm	134 lm/W	35 W	>80	Premium	1T5HO
VS4-46WLED-U-XX-FRAL	5,638 lm	127 lm/W	5,980 lm	130 lm/W	6,026 lm	131 lm/W	46 W	>80	Premium	3T8
VS8-46WLED-U-XX-FRAL	5,688 lm	127 lm/W	5,980 lm	130 lm/W	6,026 lm	131 lm/W	46 W	>80	Premium	1T12HO
VS8-65WLED-U-XX-FRAL	8,139 lm	132 lm/W	8,580 lm	132 lm/W	8,645 lm	133 lm/W	65 W	>80	Premium	2T5HO
VS8-90WLED-U-XX-FRAL	11,520 lm	128 lm/W	11,700 lm	130 lm/W	11,790 lm	131 lm/W	90 W	>80	Premium	4T8

¹LED Chips are frequently updated therefore values are nominal
²Electrical data at 25C (77F). Actual wattage may differ by +/-10%.

LINE DRAWINGS

VS2:

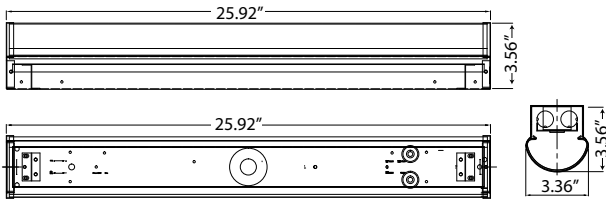

VS4:

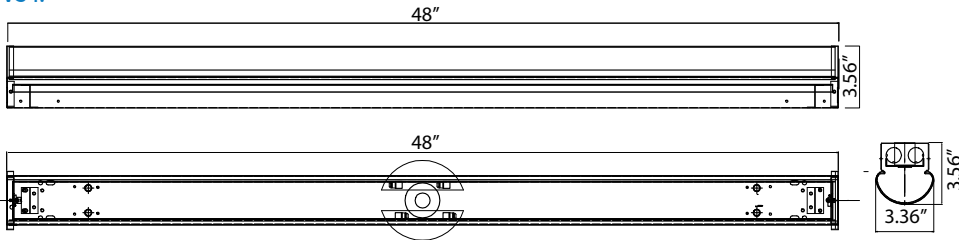

VS8:

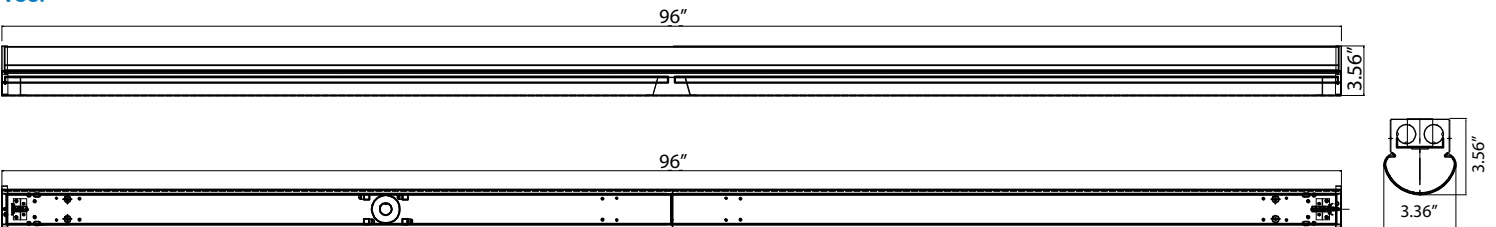

VS

Value Strip

MOUNTING OPTIONS

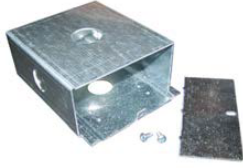

FMB
 Fixture Mounting Box
 Requires HUB. One per 4ft section



HUB 3/4
 3/4" Conduit Hub
 Use with FMB for single point mounting. One per 4ft section.



HB-XX-18Y-PAD
 Y-Toggle Cable System (xx = in)

PHOTOMETRIC REPORTS

Photometric values based upon tests performed in compliance with LM-79. IES files can be downloaded at www.ilp-inc.com

LUMINAIRE DATA	
Part Number	VS2-20WLED-U-40-FRAL
Description	2ft Value Strip, 2,600lm, with a frosted acrylic lens at 4000K
Fixture Lumens (lm)	2,600 lm
Wattage (W)	20 W
Efficacy (lm/W)	130 lm/W
Mounting	Surface
Spacing Criteria	0° = 1.18, 90° = 1.28

ZONAL LUMEN SUMMARY		
Zone	Lumens (lm)	% Fixture
0° - 40°	877	35%
0° - 60°	1,557	63%
0° - 90°	2,189	88%
90° - 180°	297	12%
0° - 180°	2,600	100%

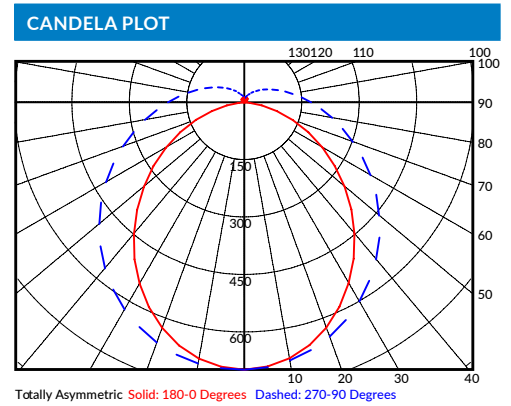

LUMINAIRE DATA	
Part Number	VS4-35WLED-U-40-FRAL
Description	4ft Value Strip, 4,600lm, with a frosted acrylic lens at 4000K
Fixture Lumens (lm)	4,620 lm
Wattage (W)	35 W
Efficacy (lm/W)	132 lm/W
Mounting	Surface
Spacing Criteria	0° = 1.20, 90° = 1.30

ZONAL LUMEN SUMMARY		
Zone	Lumens (lm)	% Fixture
0° - 40°	1,604	35%
0° - 60°	2,851	62%
0° - 90°	4,040	88%
90° - 180°	539	12%
0° - 180°	4,620	100%

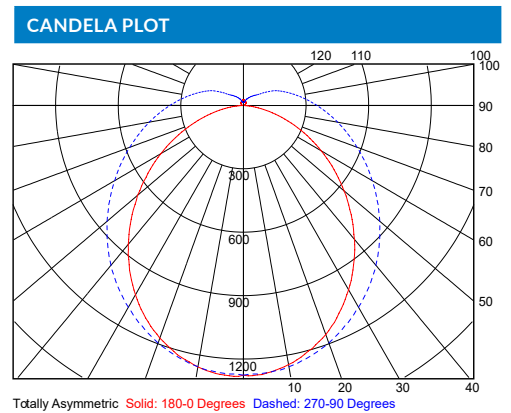

LUMINAIRE DATA	
Part Number	VS8-65WLED-U-40-FRAL
Description	8ft Value Strip, 8,500lm, with a frosted acrylic lens at 4000K
Fixture Lumens (lm)	8,580 lm
Wattage (W)	65 W
Efficacy (lm/W)	132 lm/W
Mounting	Surface
Spacing Criteria	0° = 1.20, 90° = 1.30

ZONAL LUMEN SUMMARY		
Zone	Lumens (lm)	% Fixture
0° - 40°	3,207	35%
0° - 60°	5,702	62%
0° - 90°	8,079	88%
90° - 180°	1,078	12%
0° - 180°	8,580	100%

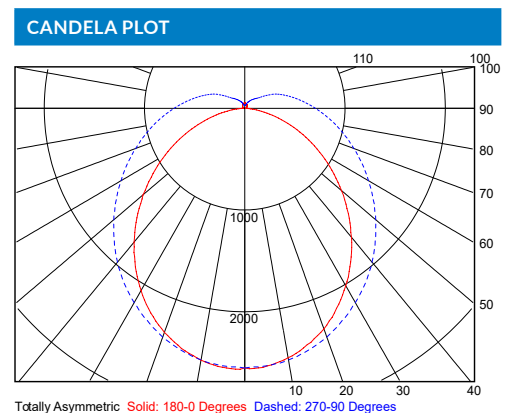

Pico® Wireless Control (for North, Central, and South America)

The Pico® wireless control is a flexible and easy to use device that allows the user to control Lutron® wireless load-control devices from anywhere in the space. This battery-operated control requires no external power or communication wiring.

Features

- Provides control for the following:
 - Caséta™ Wireless controls
 - Energi Savr Node™ and Quantum® systems, through the use of a QS sensor module (QSM)
 - GRAFIK Eye® QS wireless systems
 - HomeWorks® QS wireless systems
 - Maestro Wireless® controls
 - PowPak® modules
 - RadioRA® 2 systems
 - Serena® RF remote control shades
 - Sivoia® QS wireless systems
- Control available in a variety of button marking options.
- Easy reconfiguration for use as:
 - Handheld remote
 - Wall-mount control (with or without faceplate; faceplate adapter kit sold separately)
 - Car visor control (car visor clip sold separately)
 - A table top control (table top pedestal sold separately).
- Battery-powered. Requires no wiring.
- 10 year battery life (one CR2032 battery included).
- Can provide control of blinds, curtains, or lighting devices within a range of 30 ft (9 m) through walls and 60 ft (18 m) line-of-sight.
- BAA-compliant model numbers available. Add a “U” prefix to the model number.

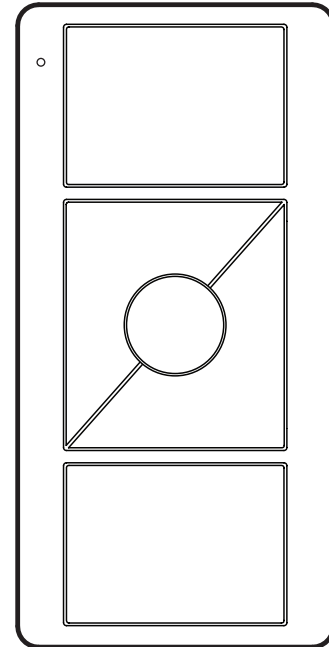

Pico® wireless control

Job Name:	Model Numbers:
Job Number:	

Specifications

Regulatory Approvals

- Lutron® Quality Systems registered to ISO 9001:2008.
- FCC Certified (U.S.A.)
- IC Certified (Canada)
- COFETEL Certified (Mexico)
- SUTEL Certified (Costa Rica)
- Anatel Certified (Brazil)

Power

- Operating Voltage 3 V_{DC}
- (1) CR2032 Battery (included)

System Communication and Capacity

- Communicates using Radio Frequency (RF) at 431 MHz to 437 MHz.
- Thousands of system addresses prevent interference between systems.
- Can be assigned to control blinds, curtains or lighting devices that are within a 30 ft (9 m) range.
- Can be configured as a scene or zone control in GRAFIK Eye® QS wireless applications.

Mounting Considerations

- Mounting of any RF devices on or in close proximity to a metal surface will drastically reduce the effective range of radio signal transmission or reception.
- All RF devices must be mounted on non-conductive materials to ensure proper performance.

Environment

- Ambient operating temperature: 32 °F to 140 °F (0 °C to 60 °C)
- Maximum 90% non-condensing relative humidity
- Indoor use only

Warranty

- 1 Year Limited Warranty
For additional Warranty information, please visit www.lutron.com/TechnicalDocumentLibrary/369-119_Wallbox_Warranty.pdf

Job Name:	Model Numbers:
Job Number:	

Model Number

For order quantities of 96 pieces or greater of the same model number, bulk packaging may be available. Mounting hardware is not included with bulk packaging. Please contact Lutron® Customer Service for availability at 1.888.LUTRON1 (1.888.588.7661).

PJ2-XXXX-GXX-XXX

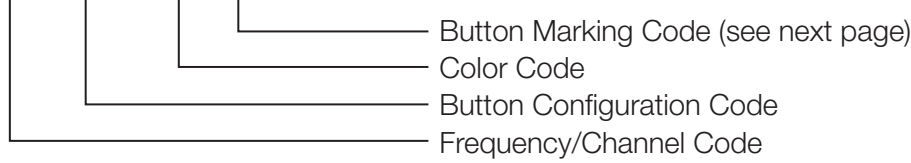

Frequency/Channel Codes:

Code

J — 431.0 - 437.0 MHz

Button Configuration Codes:

<u>Button Configuration</u>	<u>Code</u>
2 Button	2B
2 Button with Raise/Lower	2BRL
3 Button	3B
3 Button with Raise/Lower	3BRL

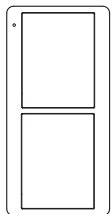

2 Button
(2B)

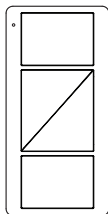

2 Button with
Raise/Lower
(2BRL)

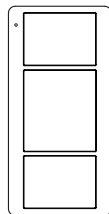

3 Button
(3B)

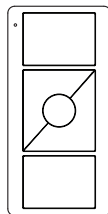

3 Button with
Raise/Lower
(3BRL)

Color Codes:

<u>Gloss Color</u>	<u>Code</u>
White	WH
Black	BL
Ivory	IV
Light Almond	LA
White/Gray	WG (Top and Raise buttons are White; Preset, Lower, and Bottom buttons are Gray)

Continued on next page...

Job Name:	Model Numbers:
Job Number:	

Model Number (continued)

PJ2-XXXX-GXX-XXX

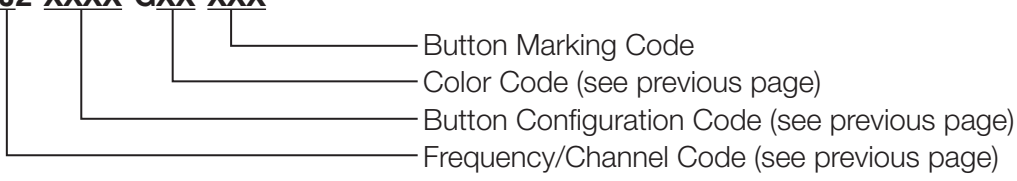

Button Marking Codes:

2 Button

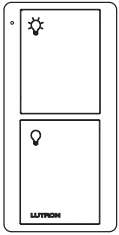

Light (L01)

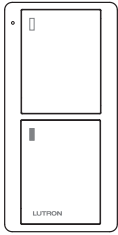

Appliance (L02)

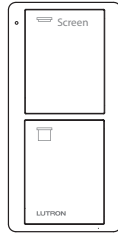

Screen (S08)

2 Button with Raise/Lower

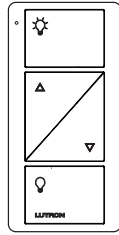

Light (L01)

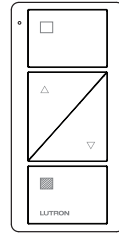

Shade (icons) (S01)

3 Button

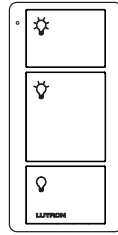

Light (L01)

3 Button with Raise/Lower

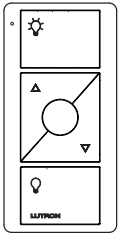

Light (L01)

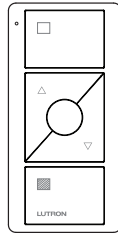

Shade (icons) (S01)

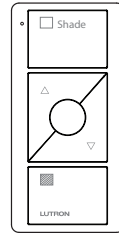

Shade (text) (S02)

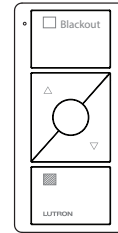

Blackout (S03)

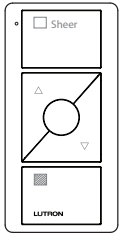

Sheer (S04)

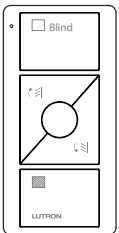

Blind (S05)

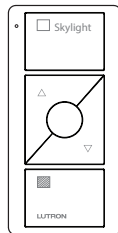

Skylight (S06)

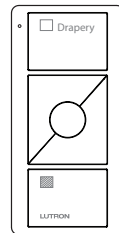

Drapery (S07)

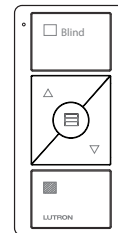

Blind (S09)

Job Name: Job Number:	Model Numbers:
--	-----------------------

Operation

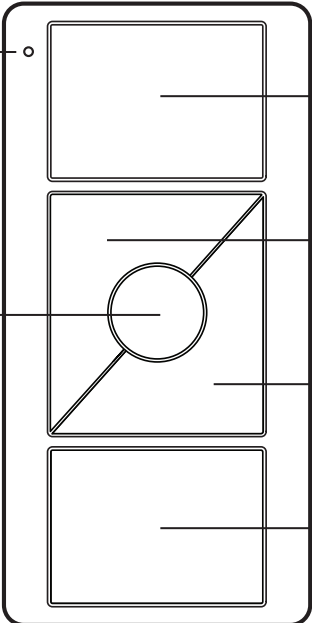

Indicator LED
Flashes to indicate a button press or when unit is in programming mode.

Preset Button (3B & 3BRL models only)
Tap once:
Devices go to preset levels/positions. Activates scene 16 when used in scene mode with GRAFIK Eye® QS wireless applications.
Press and hold:
To save new preset level or position, press and hold for 6 seconds.

Top Button
Lights brighten to full intensity and shades/ draperies go to open limit. Activates scene 1 when used in scene mode with GRAFIK Eye® QS wireless applications.

Raise Button (2BRL & 3BRL models only)
Lights increase in intensity and shades/ draperies move towards open limit.

Lower Button (2BRL & 3BRL models only)
Lights decrease in intensity and shades/ draperies move towards close limit.

Bottom Button
Lights dim to off and shades/ draperies go to close limit. Activates "OFF" scene when used in scene mode with GRAFIK Eye® QS wireless applications.

Dimensions

Measurements shown as: in (mm)

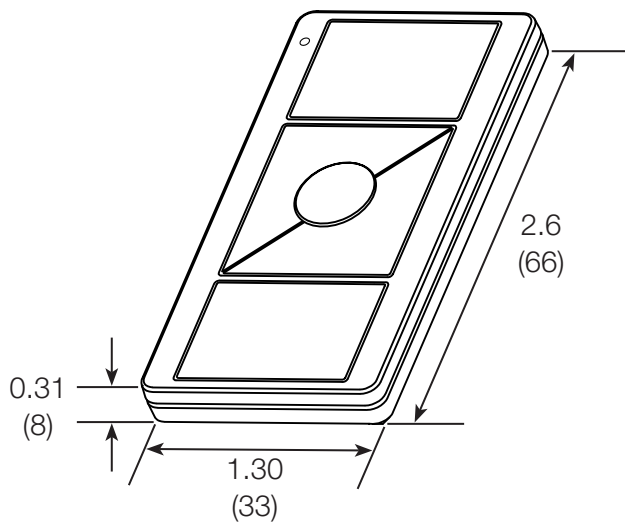

<p>Job Name:</p> <p>Job Number:</p>	<p>Model Numbers:</p>
--	-----------------------

Pico® Pedestal Model Number

Pedestals sold separately. Available in gloss finish only.

L-PEDX-XX

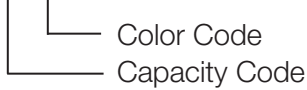

Capacity Codes:

Capacity	Code
Single	1
Double	2
Triple	3
Quadruple	4

Color Codes:

Gloss Color	Code
White	WH
Black	BL

Dimensions

Measurements shown as: in (mm)

Single Pedestal

Pedestals sold separately.

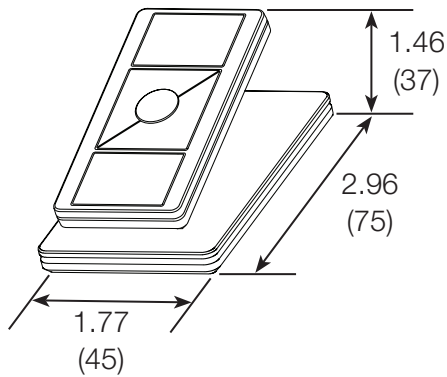

Double Pedestal

Pedestals sold separately.

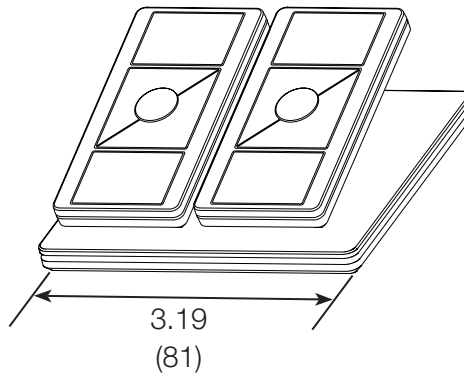

Triple Pedestal

Pedestals sold separately.

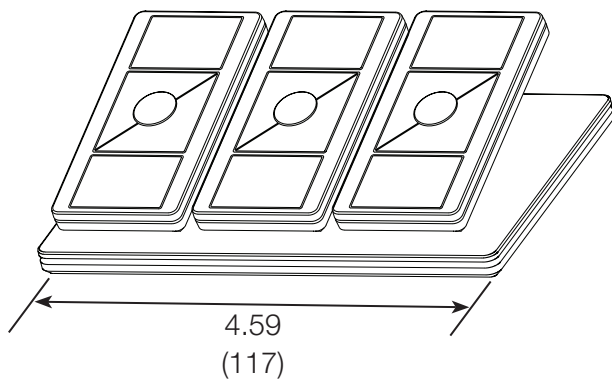

Quadruple Pedestal

Pedestals sold separately.

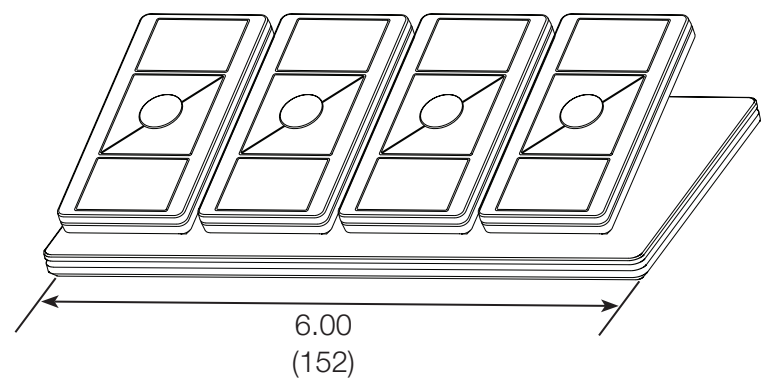

Job Name:	Model Numbers:
Job Number:	

Mounting Options

Stand Alone Mounting

Adhesive-Mount
(included with Pico® wireless control)

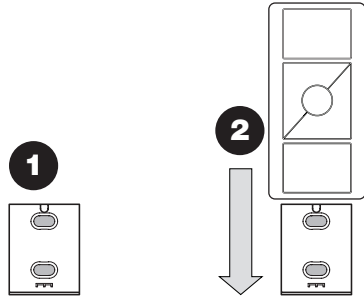

Screw-Mount (sold separately)
Model PICO-SM-KIT

Note: Kit includes special screws to be used for more permanent mounting and/or for non-smooth surfaces.

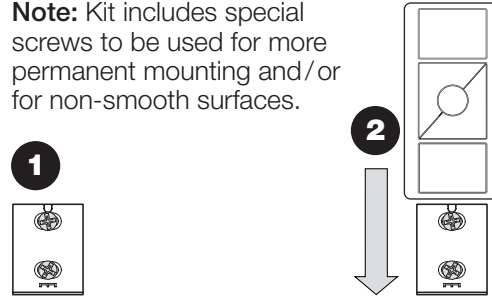

Wallbox Adapter

Model PICO-WBX-ADAPT
(sold separately)

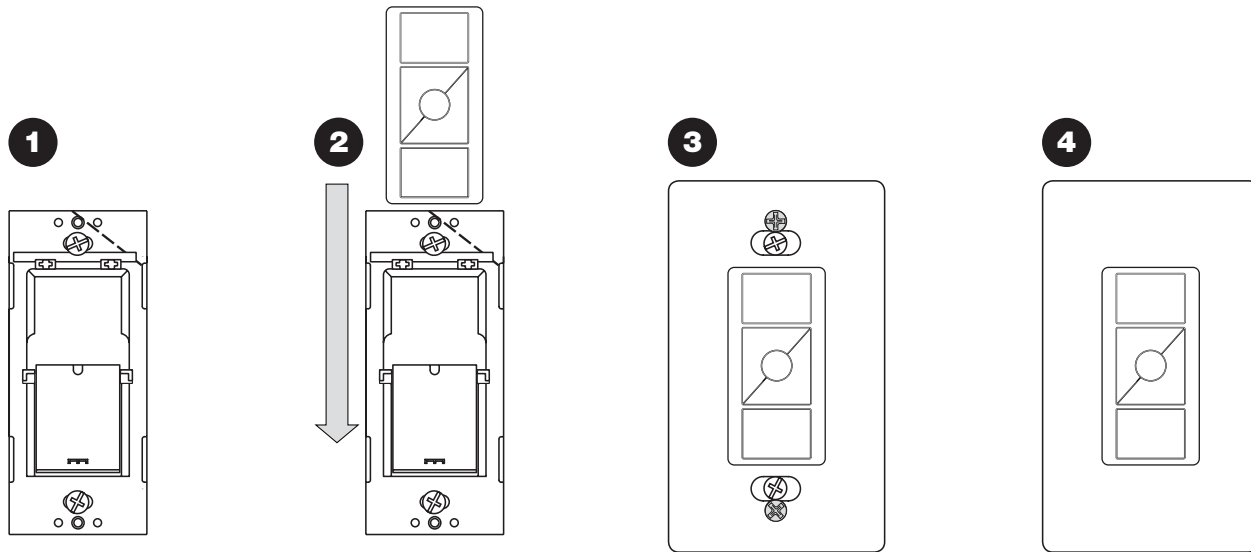

*Wallplate adapter / wallplate sold separately

Continued on next page...

Job Name:	Model Numbers:
Job Number:	

Mounting Options *(continued)*

Wall-Mounting Kit

Model PJ2-WALL-WH-L01R
(sold separately)

Kit includes:

- Pico® wireless control
- Claro® wallplate (with wallplate adapter)
- Wallbox adapter

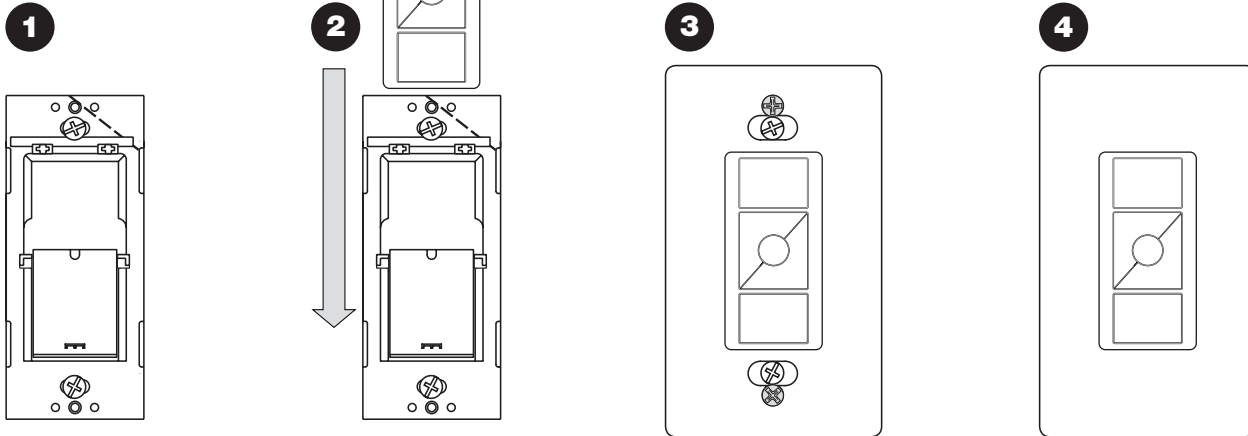

Mounting to Metal Surfaces

Coming Soon (sold separately)

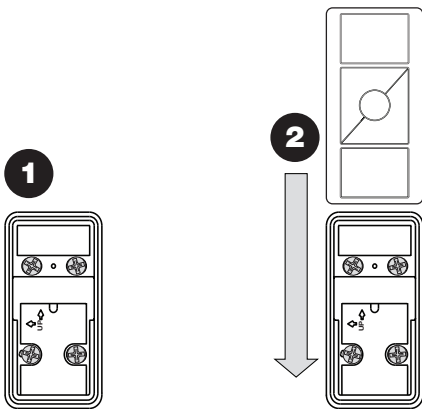

Car Visor

Model PICO-CARVISOR-CL (sold separately)

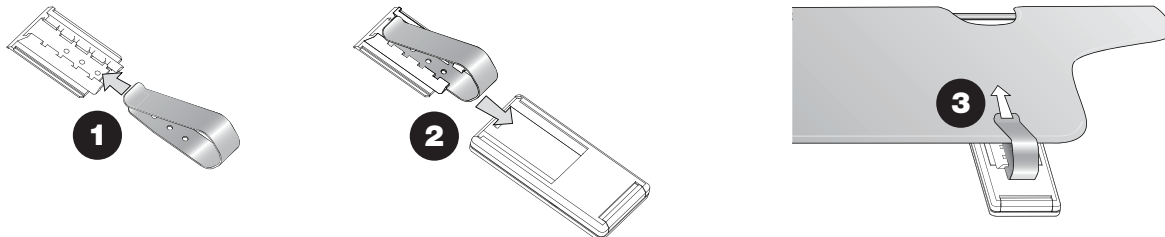

Job Name:	Model Numbers:
Job Number:	

Vive PowPak Dimming Module with 0–10 V_{ac} Control

The PowPak Dimming Module with 0–10 V_{ac} Control is a radio frequency (RF) control that operates 0–10 V_{ac} controlled fluorescent ballasts or LED drivers based on input from Pico remote controls and Radio Powr Savr sensors. The Dimming Module with 0–10 V_{ac} Control is ideal for small areas (e.g., classrooms, conference rooms, private offices). Communication with RF input devices (e.g., Pico remote controls, Radio Powr Savr sensors) is accomplished by using Lutron Clear Connect RF Technology.

These products are also compatible with the Vive hub which enables a simple setup process using a standard web browser on any Wi-Fi enabled phone, tablet or computer. It also enables control and monitoring of all Vive devices. The Vive hub can be added at any time. System reprogramming will be required. For a complete list of features supported with the Vive hub, see specification submittal 369902.

Note for Replacement: RMJS/URMJS - the “S” model can replace the non-”S” model.

Features

- Controls up to 60 mA of 0–10 V_{ac} controlled fixtures together
- Switches up to 8 A total
- 0–10 V_{ac} control link automatically sources or sinks to the third party fixtures
- Configurable high- and low-end trim
- Various operating voltages available; refer to model number chart below for details on voltage requirements
- Receives wireless inputs from up to 10 Pico remote controls, 10 Radio Powr Savr occupancy/vacancy sensors, and 1 Radio Powr Savr daylight sensor
- Utilizes Lutron Clear Connect RF Technology; refer to model number chart below for frequency band data
- Mounts to a US-style junction box through a standard-size knockout

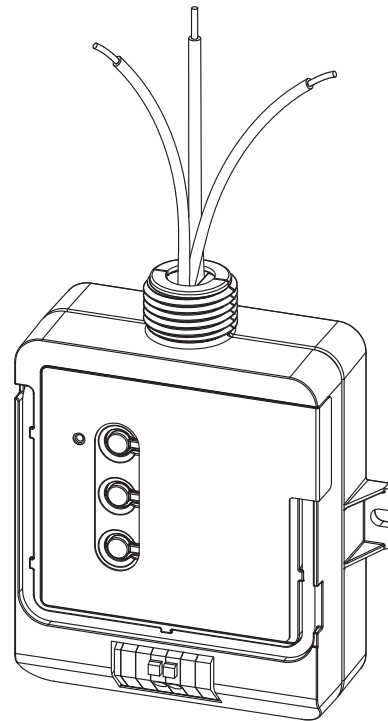

Job Name:	Model Numbers:
Job Number:	

Models

Model Number	Region	Operating Voltage	Frequency Band
RMJS-8T-DV-B	U.S.A., Canada, Mexico	120/277 V~	431.0–437.0 MHz
URMJS-8T-DV-B	U.S.A. (BAA Compliant)	120/277 V~	431.0–437.0 MHz

NOTE: Contact Lutron for frequency band compatibility for your geographic region if it is not indicated above.

Job Name:	Model Numbers:
Job Number:	

Specifications

Regulatory Approvals

RMJS- and URMJS- models

- UL Listed
- FCC approved. Complies with the limits for a Class B device, pursuant to Part 15 of the FCC rules
- Complies with requirements for use in other spaces used for environmental air (plenums) per NEC 2014 300.22(C)(3)
- Listed in accordance to CAN/ULC S102.2-2010 with a Flame Spread Rating of 0 and a Smoke Developed Classification of 40, with a minimum spacing of 6 ft (1.83 m) off center
- cUL and IC (Canada) (RMJS- only)
- COFETEL (Mexico) (RMJS- only)
- NOM (Mexico) (RMJS- only)

Power

- Operating voltage
 - **RMJS- and URMJS- models:** 120/277 V \sim 50/60 Hz

Output Ratings

- Switch rating of 8 A. Rated for resistive or capacitive loads as defined by IEC/EN 60669-2-1
- 0–10 V \equiv control link for 60 mA maximum output, source or sink automatically configures

Other Power Specifications

- Standby power:
 - 240–277 V \sim 610 mW
 - 120 V \sim 550 mW
- BTU/hour when fully loaded: 9
- Works with all ballasts and drivers that provide a current source that is compliant to IEC 60629 Annex E.2, and whose inrush current does not exceed NEMA410 standards for electronic ballast/driver

System Communication

- Operates using Clear Connect RF Technology for reliable wireless communication; refer to model number chart on page 1 for frequency band details
- RF range is 30 ft (9 m)
- Wireless sensors and controls must be located within 60 ft (18 m) line of sight, or 30 ft (9 m), through walls, of the associated control module. The 60 ft (18 m) range is not reduced by a ceiling tile obstruction.

Environment

- Ambient operating temperature: 32 °F to 104 °F (0 °C to 40 °C)
- 0% to 90% humidity, non-condensing
- For indoor use only
- All drivers and ballasts used with Vive wireless controls must comply with the limits for a Class A device pursuant to Part 15 of the FCC Rules

0–10 V \equiv Control Link

- Communicates with up to 60 mA of fixtures
- Control link is IEC SELV/NEC Class 2
- 0–10 V \equiv control can be installed using NEC Class 1 or Class 2 wiring methods. Alternately, it can be wired to basic or double-insulated devices
- Terminals accept one 18 AWG to 16 AWG (0.75 mm² to 1.5 mm²) solid wire
- Always consult local wiring codes
- Compatible with ANSI E1.3 2001 (R2006), IEC 60929 Annex E

Job Name: Job Number:	Model Numbers:
------------------------------	----------------

Specifications *(continued)*

Default Operation

- Associated wireless input devices control all connected fixtures together
- Occupancy Sensors:
 - Occupied: 100%; Unoccupied: 0% (OFF)
- Pico Remote Controls:
 - On: 100%; Favorite Level: 50%; Off: 0% (OFF)
- Daylight Sensor: Decreases electric light in response to additional available daylight

Key Design Features

- LED status indicator shows load status and provides programming feedback
- Configurable high-end and low-end trim
- Power failure memory: If power is interrupted, connected loads will return to the previous level prior to interruption
- 0–10 V_{DC} control mis-wire protection up to 30 V_{DC}

Advanced Configurations

Pico Remote Controls

- Up to 10 Pico remote controls
- Favorite levels can be set for each Pico remote control

Radio Powr Savr Daylight Sensor

- The Radio Powr Savr daylight sensor will affect all connected ballast and LED drivers equally
- For multiple rows of daylighting, a separate PowPak Dimming Module with 0–10 V_{DC} must be used for each daylighting row

Minimum Light Level Setting (optional)

- Certain applications, such as hallways, may require that the lights never turn off. For these areas, select the minimum light level option and the load will lower to programmed low-end level. Default operation lowers to OFF.

High- and Low-End Trim

- High-end and low-end trim affect all connected fixtures equally, and can be configured from the PowPak Dimming Module.
- Adjustable low-end trim (0%–45%). Trimmable low-end can ensure a stable light level. Some fixtures will flicker or drop out if trimmed too low.
- The maximum light output of connected fixtures can be decreased down to 55% for energy savings in over-lit spaces.

Note: The perceived light output of low-end trim may vary between fixture manufacturers and model numbers. For best results, do not mix different ballasts or drivers on the same 0–10 V_{DC} circuit.

Radio Powr Savr Occupancy Sensors

- Radio Powr Savr occupancy and vacancy sensors control all connected ballasts or drivers.
- Pico remote controls can be used to adjust the Occupied levels of fixtures that they control from 1% to 100% (of output signal) or can make them unaffected by Occupancy events.
- Vacancy events (area becomes unoccupied) turn all ballasts and driver models off or to minimum light level.

Job Name:	Model Numbers:
Job Number:	

System Diagram (RMJS- and URMJS- models)

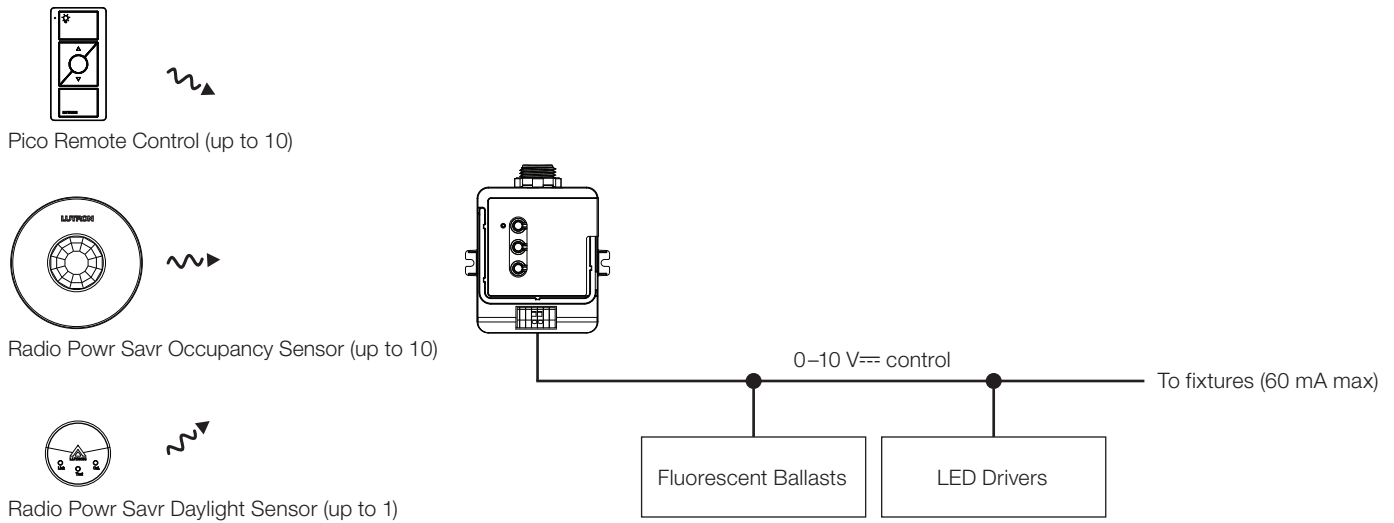

Wiring Schematic (RMJS- and URMJS- models)

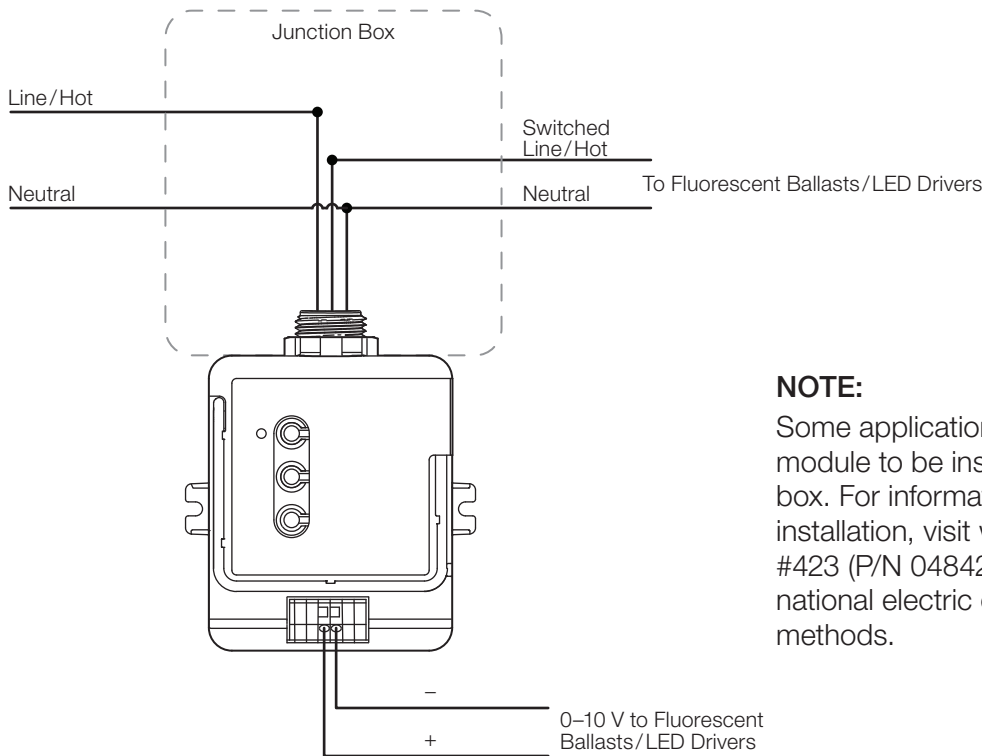

NOTE:

Some applications (in the U.S.A.) require the PowPak module to be installed inside an additional junction box. For information about how to perform this installation, visit www.lutron.com, Application Note #423 (P/N 048423). Please consult all local and national electric codes for proper installation methods.

Job Name:	Model Numbers:
Job Number:	

Dimensions

Dimensions are shown as: in (mm)

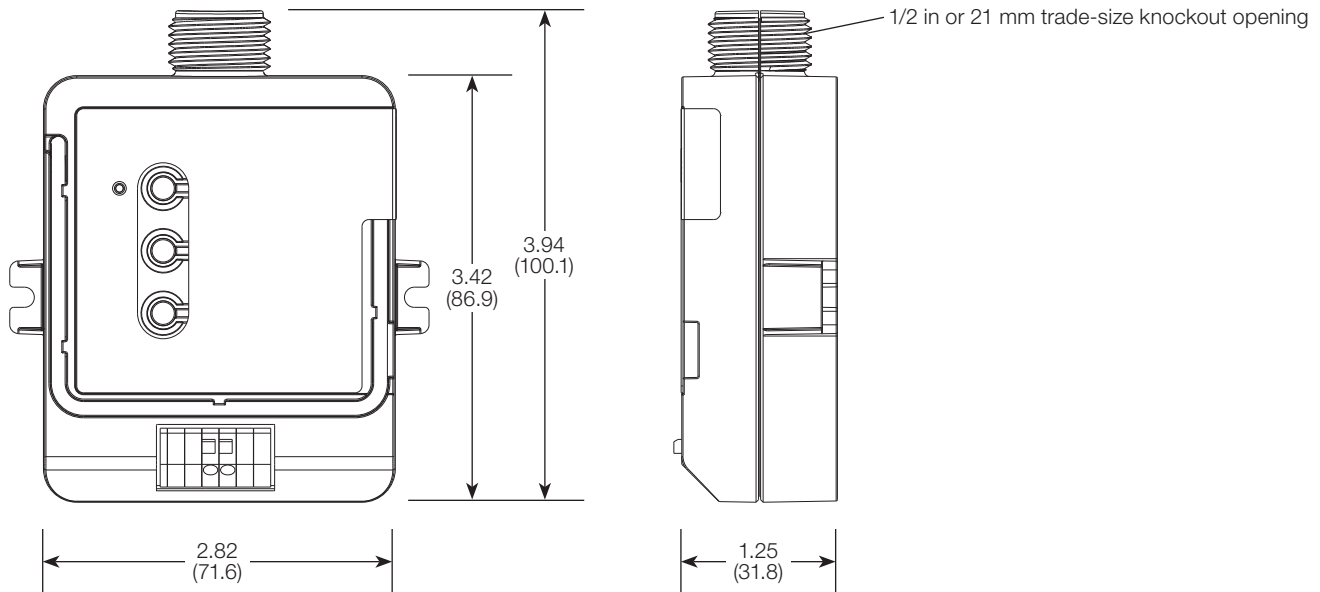

Range Diagram

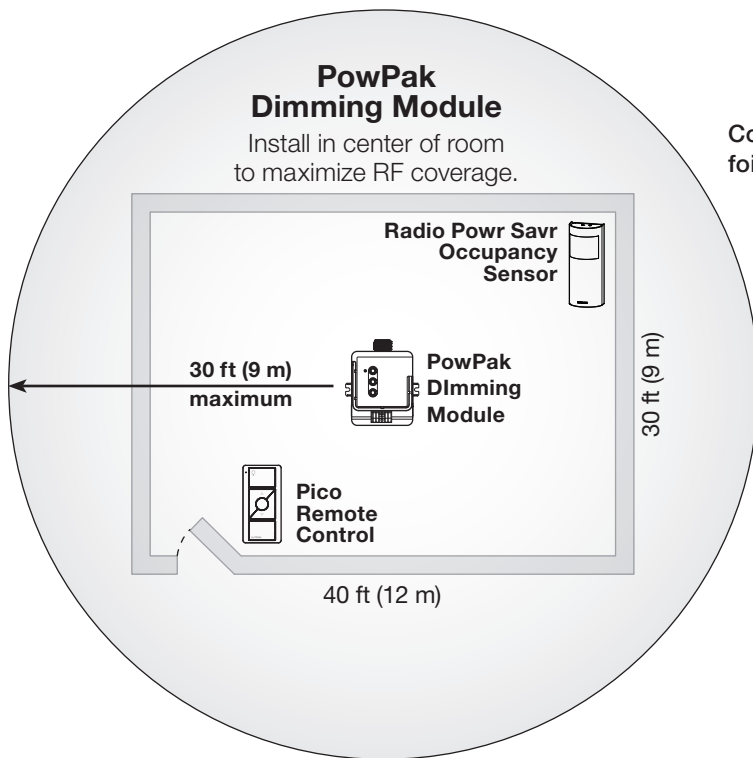

Contact Lutron first for applications using foil-backed or metallic ceiling tiles.

NOTE: Wireless sensors and controls must be located within 60 ft (18 m) line of sight, or 30 ft (9 m), through walls, of the associated control module. The 60 ft (18 m) range is not reduced by a ceiling tile obstruction.

Lutron, Lutron, PowPak, Clear Connect, and Pico are trademarks of Lutron Electronics Co., Inc. registered in the U.S. and other countries. Radio Powr Savr and Vive are trademarks of Lutron Electronics Co., Inc.

Job Name:	Model Numbers:
Job Number:	

Mounting Options

Standalone Mounting: Adhesive-Mount

Included with Pico® wireless remote

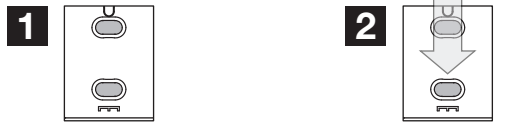

Standalone Mounting: Screw-Mount

Model PICO-SM-KIT (sold separately)

Kit includes special screws to be used for more permanent mounting and/or for non-smooth surfaces.



Wallbox Adapter

Model PICO-WBX-ADAPT

(sold separately)

Wallplate adapter/wallplate sold separately.

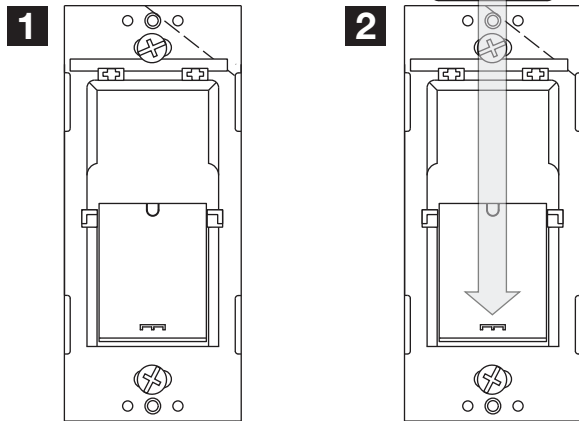

Mounting to a Car Visor

Model PICO-CARVISOR-CL (sold separately)

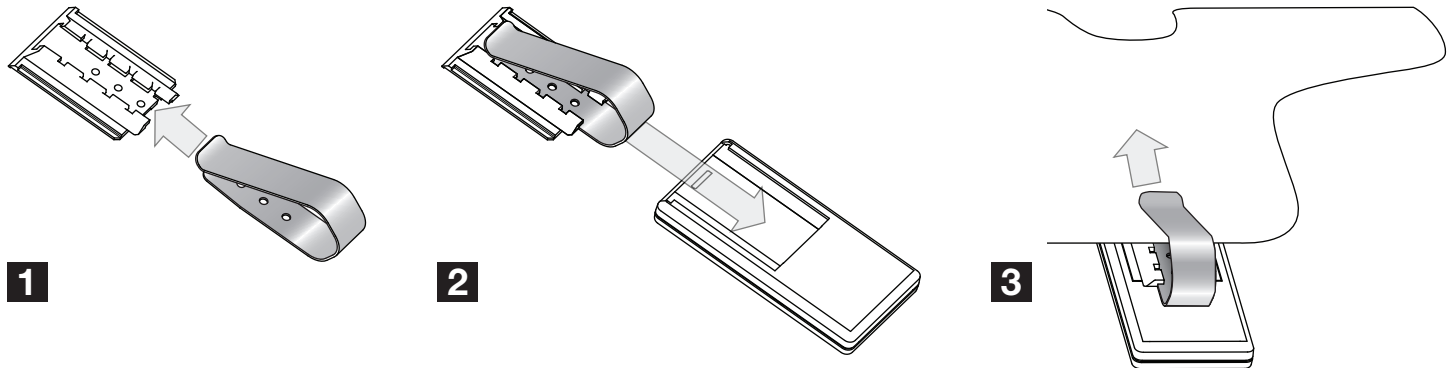

Job Name:	Model Numbers:	
<input type="text"/>	<input type="text"/>	<input type="text"/>
Job Number:	<input type="text"/>	<input type="text"/>

Wireless Ceiling Mount Sensor

Lutron’s ceiling-mounted occupancy/vacancy sensors are wireless, battery-powered passive infrared (PIR) sensors that automatically control lights via RF communication to compatible dimming and switching devices. These sensors detect the heat from people (IR radiation of 9.5 μm) moving within an area to determine when the space is occupied. The sensors then wirelessly transmit the appropriate commands to the associated dimming and switching devices to turn the lights on or off automatically. They combine both convenience and exceptional energy savings potential along with ease of installation.

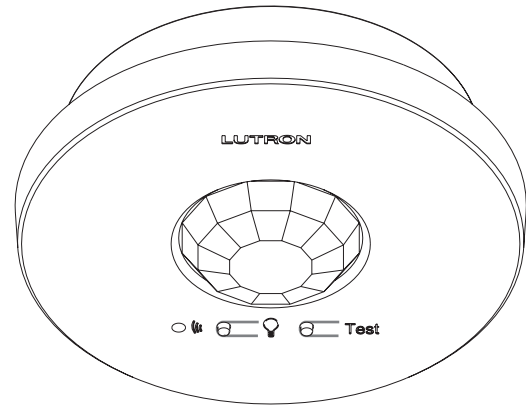

Features

- Wireless occupancy sensor has 3 settings available: Auto-On/Auto-Off, Auto-On Low-Light/Auto-Off, and Manual-On/Auto-Off
- Auto-On Low-Light feature will only turn lights on automatically if there is less than approximately 10 Lux (1 fc) of ambient light
- Vacancy only model available to meet California (U.S.A.) Title 24 requirements
- Uses Clear Connect™ technology
- Passive infrared motion detection with exclusive Lutron XCT™ Technology for fine motion detection
- 360° coverage ranges from 324 sq ft (98 sq m) to 676 sq ft (206 sq m), depending on mounting height
- Simple and intuitive adjustments available for Timeout, Auto-On, and Activity settings
- Supports advanced occupancy features, such as dependent occupancy groups and customizable occupied/unoccupied presets in some systems
- Multiple sensors can be added for extended coverage—refer to product specification submittal of receiving device to determine system limits
- Lens illuminates during test mode to verify ideal locations
- Multiple ceiling-mount methods available for different ceiling materials
- Front accessible test buttons make setup easy
- 10-year battery life design
- RoHS compliant

Models Available

- **LRFX-OCR2B-P-WH**
 - Color Code
 - Frequency/Channel Code
- LRF2-VCR2B-P-WH
 - Available for Vacancy Only Sensor
 - Channel Code 2 Only

Frequency/Channel Codes

- 2 = 431.0 – 437.0 MHz (US, Canada, Mexico, Brazil)
- 3 = 868.125 – 869.850 MHz (Europe and UAE)
- 4 = 868.125 – 868.475 MHz (China and Singapore)
- 5 = 865.5 – 866.5 MHz (India)
- 6 = 312.3 – 314.8 MHz (Japan)
- 7 = 433.05 – 434.79 MHz (Hong Kong)

Color Code

WH = White

Compatible RF Devices

- For use with Lutron® products only
 - Communicates to various wireless Lutron® systems*
- * Contact Lutron® Customer Service at www.lutron.com for frequency/channel code compatibility with your particular geographic region, and for integrating with other Lutron® lighting and shading products.

Job Name:	Model Numbers:
Job Number:	

Specifications

Regulatory

- Lutron® Quality Systems Registered to ISO 9001:2008

Standards

LRF2-

- FCC certified
- IC certified
- COFETEL certified
- ANATEL certified
- SUTEL certified
- Meets CA (U.S.A.) Energy Commission Title 24 requirements

LRF3-

- CE Marked (European Union) [expected Q4 2011]
- TRA Type Approved (United Arab Emirates) [expected Q4 2011]

LRF4-

- SRRC Type Approved (Mainland China) [expected Q4 2011]
- iDA Registered (Singapore) [expected Q4 2011]

LRF5-

- WPC Type Approved (India)

LRF6-

-  007YUUL0689

LRF7-

- FCC certified

Power/Performance

- Operating voltage: 3 V_{DC}
- Operating current: 14 µA nominal
- Requires one CR 123 lithium battery
- 10-year battery life design
- Non-volatile memory (saved changes are stored during power loss)

Environment

- Temperature: 32 °F to 104 °F (0 °C to 40 °C)
- For indoor use only

Range

• LRF2, LRF3, LRF4, LRF5, LRF7

Local load controls must be located within 60 ft (18 m) line of sight, or 30 ft (9 m), through walls, of a sensor.

• LRF6

Local load controls must be located within 40 ft (12.2 m) line of sight or 23 ft (7 m), through walls, of a sensor.

Sensor Coverage Test

- Front accessible test button
- Lens illuminates orange in response to motion during test mode and is visible from 60 ft (18 m)

Wireless Communication Test

- Front accessible test button
- Turn associated loads on and off

Timeout Options

- 1 minute *
- 5 minutes
- 15 minutes – default setting
- 30 minutes

Auto-On Options (Occupancy Versions Only)

- “Enabled” * – Sensor turns lights ON and OFF automatically – default setting.
- “Low Light” – Sensor turns lights ON automatically only in low ambient light conditions. Sensor turns lights OFF automatically.
- “Disabled” ** – Lights must be turned ON manually from dimming or switching device. Sensor turns lights OFF automatically.

Activity Options

- Low Activity (Ⓕ) – default setting
- Medium Activity (Ⓖ)
- High Activity (Ⓗ)

* Intended for use in high-activity, briefly occupied areas only

** There is a 15-second grace period that begins when the lights are automatically turned off, during which the lights will automatically turn back on in response to motion. This grace period is provided as a safety and convenience feature in the event the lights turn off while the room is still occupied, so that the user does not need to manually turn the lights back on. After 15 seconds, the grace period expires and the lights must be manually turned on.

Job Name:	Model Numbers:
Job Number:	

Dimensions

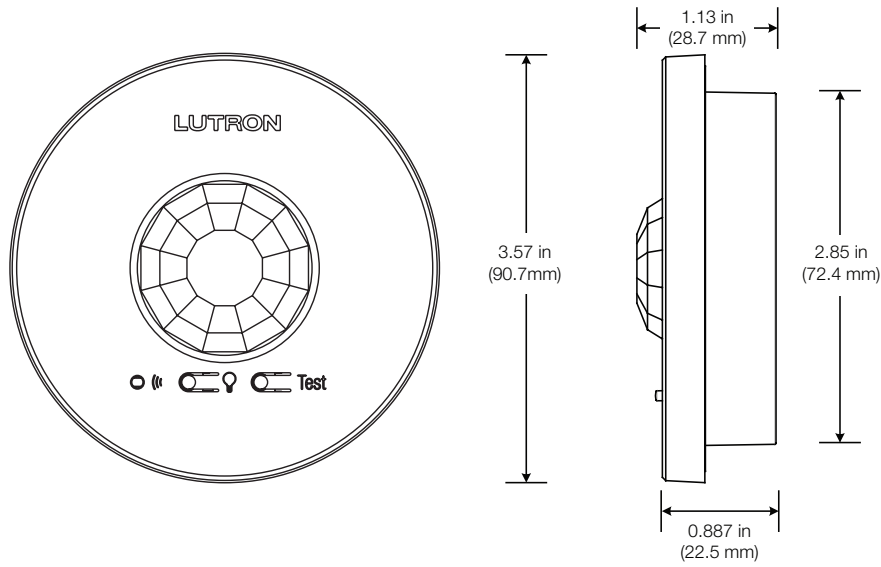

Job Name:	Model Numbers:
Job Number:	

Range Diagrams

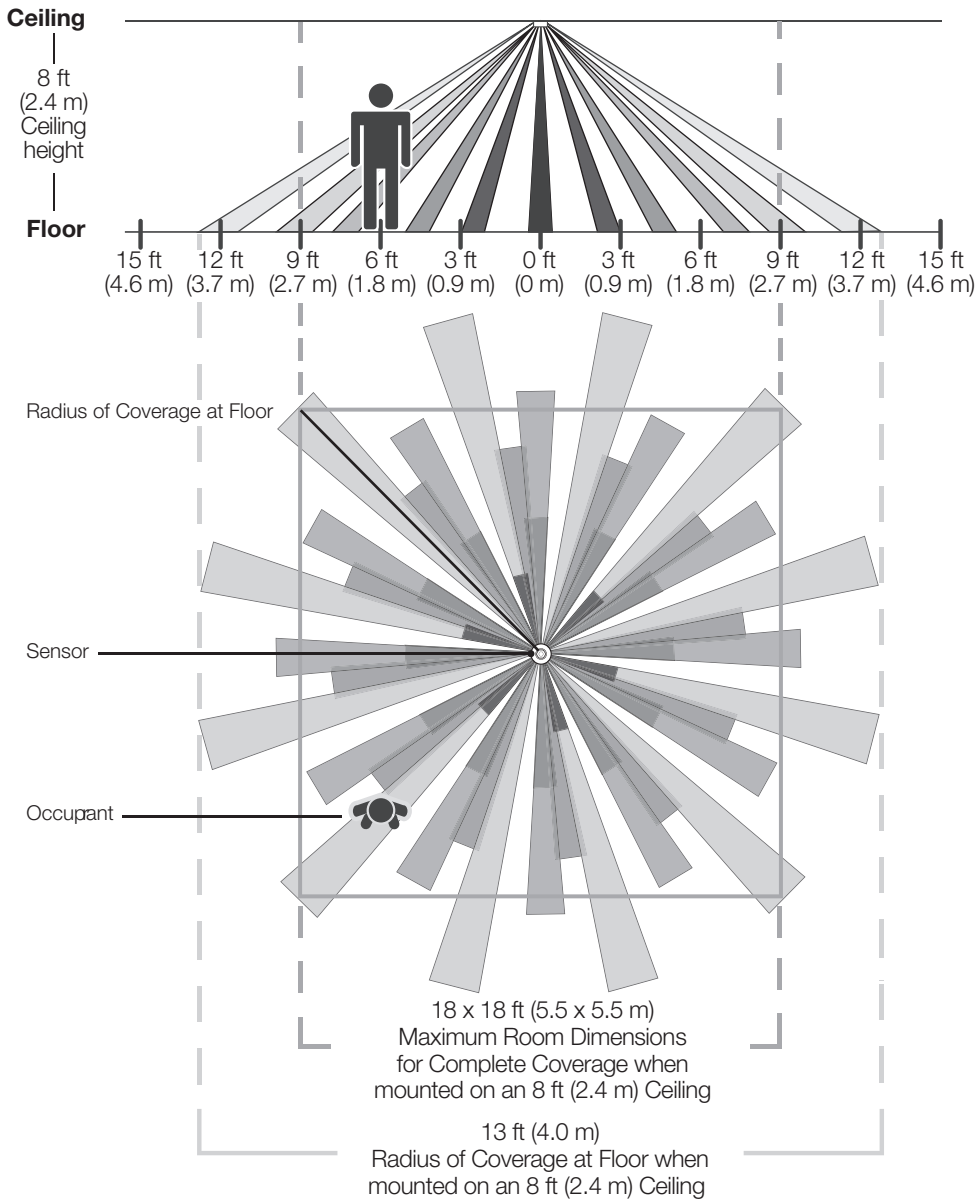

Sensor Coverage Chart (for sensor mounted in center of room)

Ceiling height	Maximum room dimensions for complete floor coverage*	
8 ft (2.4 m)	18 ft x 18 ft (5.5 m x 5.5 m)	324 ft ² (30.2 m ²)
9 ft (2.7 m)	20 ft x 20 ft (6.1 m x 6.1 m)	400 ft ² (37.2 m ²)
10 ft (3.0 m)	22 ft x 22 ft (6.7 m x 6.7 m)	484 ft ² (44.9 m ²)
12 ft (3.7 m)	26 ft x 26 ft (7.9 m x 7.9 m)	676 ft ² (62.4 m ²)

* 12 ft (3.7 m) is the recommended maximum mounting height

Job Name:	Model Numbers:
Job Number:	

Installation Overview

Sensor Placement

- The sensor's ability to detect motion requires line of sight of room occupants. The sensor must have an unobstructed view of the room. **DO NOT** mount behind or near tall cabinets, shelves, hanging fixtures, ceiling fans, etc. The sensor cannot see through glass objects such as patio or shower doors.
- Hot objects and moving air currents can affect the sensor's performance. To ensure proper operation, the sensor should be mounted at least 4 ft (1.2 m) away from HVAC vents and light bulbs that are below the ceiling line.
- The sensor's performance depends on a temperature differential between the ambient room temperature and that of room occupants. Warmer rooms may reduce the sensor's ability to detect occupants.
- **LRF2, LRF3, LRF4, LRF5, LRF7:** The sensor should be mounted within 60 ft (18 m) line of sight or 30 ft (9 m) through walls of the associated dimming and switching receiving devices.
- **LRF6:** The sensor should be mounted within 40 ft (12.2 m) line of sight or 23 ft (7 m) through walls, of the associated dimming and switching receiving devices.

Mounting

- Temporary mounting is optional to test sensor coverage and wireless communication before permanently installing the sensor.

Drop Ceiling (Compressed Fiber Ceiling Tile)

- The ceiling tile mounting wire is provided for both temporary and permanent mounting of the sensor to ceiling tiles. It is designed to allow temporary mounting, testing, and repositioning (if necessary) of the sensor without damaging a ceiling tile. Once the sensor's final position has been chosen, the mounting wire should be twisted to lock the sensor in place permanently.

Solid Ceiling (Drywall, Plaster, Concrete, or Wood)

- Temporary mounting: Ten (10) temporary mounting strips can be purchased in the kit L-CMDPIRKIT for temporarily mounting and testing the sensor.
- Permanent mounting: Screws and anchors (for drywall or plaster) provided to mount sensor.

Recess Mount

- Do not recess mount ceiling sensor in a metal surface.
- Ceiling mount clamps internally to ceiling. Sensor twist-locks into mount, sits flush with ceiling (as shown below).
- Opening is 3 in (76.2 mm) in diameter.
- Purchased as a separate kit: L-CRMK-WH.

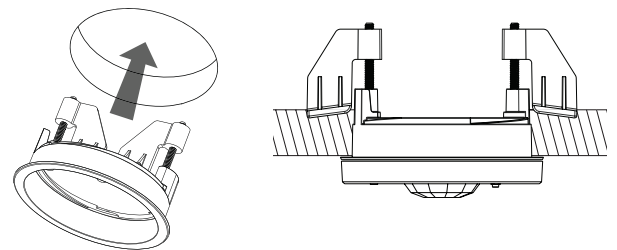

Job Name:	Model Numbers:
Job Number:	

Lens Masking

Whenever possible, the sensor should be installed in a location where it cannot easily see into areas outside the intended space, such as hallways or adjacent rooms. If this situation cannot be avoided, portions of the lens may be masked to block the sensor's view of the undesired areas. Ten (10) PIR Lens Masks can be purchased in the kit L-CMDPIRKIT.

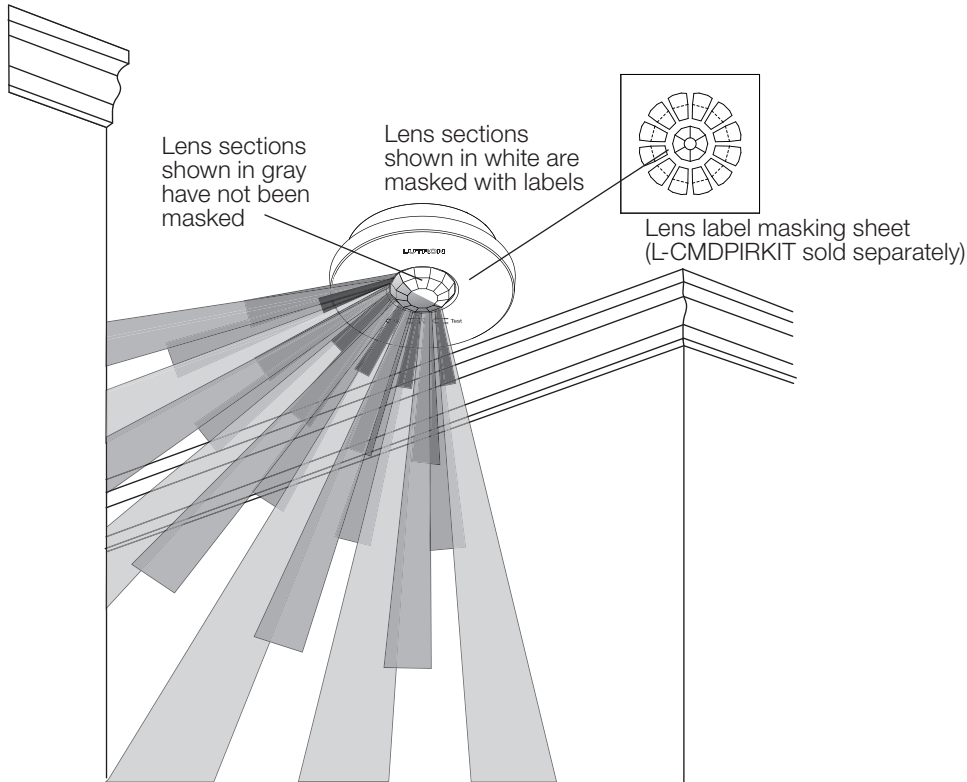

Job Name:	Model Numbers:
Job Number:	

Project Name:

Part Number:

Type:



OPEN FACE WALL PACK

OUTDOOR



407-478-3759
www.ilp-inc.com

FEATURES

- Rugged die-cast aluminum housing
- Bronze polyester powder coat finish (std.)
- Custom and factory select colors available¹
- Non-Cutoff Type IV distribution
- Optional Hood for semi-cutoff Type IV distribution
- Impact resistant frosted low glare prismatic polycarbonate lens with UV stabilizers
- Silicone lens gasket and rubber housing gasket provide secure watertight seal
- Built in base bubble level for easy installation
- ½" coin plugs with o-rings for conduit or optional photocell
- 120-277V Universal Voltage
- 0-10V Dimmable Driver (std.)
- Battery backup & cold weather battery options available
- PIR Occupancy, Photocell, & Bi-Level Dimming sensors available
- 4000K & 5000K CCT
- >70 Color Rendering Index (CRI)
- Calculated L70 >75,000 Hours @ 25°C per TM-21-11
- IP65 Rated Luminaire
- 5 Year Warranty
- ETL Listed for Wet Locations
- DesignLights Consortium® Qualified Luminaire



¹Contact factory for pricing and availability



SUITABLE APPLICATIONS

- Schools
- Warehouses
- Shopping Center
- General Area Lighting

ORDERING GUIDE:

SERIES	WATTS	DRIVER	CCT
WPSO Small Open Face Wall Pack	30W	UNIV 120-277V	50 40
WPMO Medium Open Face Wall Pack	45W 70W		
WPLO Large Open Face Wall Pack	90W 135W		

OPTIONS		CONTROLS OPTIONS ¹	
Factory Installed		Basic—Ship with Accessories	
SP1⁵	10kA Max Univolt Surge Protector	PCU	Photocell Universal Voltage (120-277V)
SP2⁵	22kA Max Univolt Surge Protector	PC120	Electronic UNIV Photocell 120V
SP480V02	20kA Max 480V Surge Protector	PC277	Electronic UNIV Photocell 277V
FUSE/SXXX	Single-line Voltage Fuse (120, 277, 347)		
FUSE/DXXX	Single-line Voltage Fuse (208, 240, 480)		
FI/ILBCP05⁴	5W LED Factory Installed Battery Backup		
FI/ILBCP05/HE⁴	5W LED Factory Installed Battery Backup-CEC Title 20 Compliant		
FI/ILBCP07^{3,4}	7W LED Factory Installed Battery Backup		
FI/ILBCP07/HE^{3,4}	7W LED Factory Installed Battery Backup-CEC Title 20 Compliant		
FI/ILBCP10^{3,4}	10W LED Factory Installed Battery Backup		
FI/ILBCP10/HE^{3,4}	10W LED Factory Installed Battery Backup-CEC Title 20 Compliant		
FI/ILBCP12^{3,4}	12W LED Factory Installed Battery Backup		
LEDBBCT⁴	20W UNIV CT Battery backup (-4°F-80°F)		
LEDBBCT10^{3,4}	10W UNIV CT Battery backup (-4°F-80°F)		
SMLxxxx	Specified Lumen Output (xxxx=lumen)		
SD480	480V Step Down Transformer		
SD347	347V Step Down Transformer		
Ship With Accessories		Basic—Factory Installed	
FSIR-100	Remote Programming Tool for FSP-211 Sensor	WLOS	On/Off Occupancy Sensor
HD/WPMO	Medium Hood/Glare Shield - Field Installed	USBD²	User Select Bi-Level Dim Occ. Sensor
HD/WPLO	Large Hood/Glare Shield - Field Installed	BDxx	Preset Bi-Level Dim Sensor (xx=% eg. 20,30)
		BDxxPC	Preset Bi-Level Dim Sensor w/ Photocell (xx=% eg. 20,30)

¹ Only 1 selection allotted for controls options

² Requires (1) FSIR/100 remote configuration tool to program sensor

³ WPLO series model only

⁴ Not available with SD347 or SD480 Options

⁵ SP1/SP2 specified in combination with Battery Backups, separate surge protectors are required per electrical line

OPEN FACE WALL PACK

OUTDOOR



QUICK SHIP ITEMS:

SERIES	WATTS	DRIVER	COLOR
WPSO Small Open Face Wall Pack	30W	U 120-277V	50 40
WPMO Medium Open Face Wall Pack	45W		
WPMO Medium Open Face Wall Pack	70W		
WPLO Large Open Face Wall Pack	90W 135W		

LED SYSTEMS INFORMATION ¹	4000K		5000K		Watts ²	DLC Listing	Replaces
	Part Numbers	Lumens	Efficacy	Lumens			
WPSO-30W	4,097 lm	130 lm/W	4,203 lm	134 lm/W	31 W	Premium	100W MH
WPMO-45W	5,049 lm	113 lm/W	4,950 lm	110 lm/W	45 W	Standard	175W MH
WPMO-70W	7,770 lm	112 lm/W	7,900 lm	113 lm/W	70W	Standard	250W MH
WPLO-90W	10,414 lm	116 lm/W	9,950 lm	111 lm/W	90 W	Standard	320W MH
WPLO-135W	15,340 lm	114 lm/W	15,550 lm	115 lm/W	135W	Standard	400W MH

¹LED Chips are frequently updated therefore values are nominal
²Electrical data at 25C (77F). Actual wattage may differ by +/-10%.

LINE DRAWINGS

WPSO:

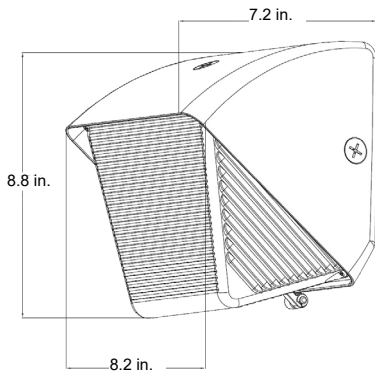

WPMO:

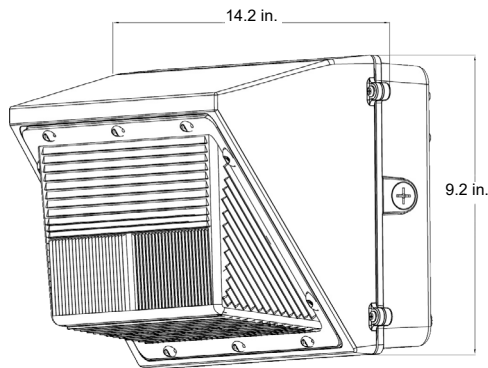

WPLO:

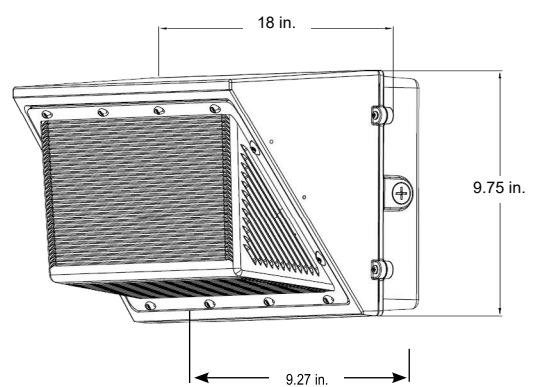

OPTIONS

HD/WPMO Medium Hood/Glare Shield - Field Installed

HD/WPLO Large Hood/Glare Shield - Field Installed

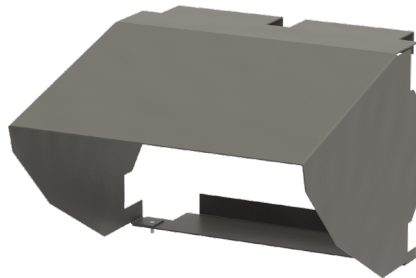

HD/WPMO

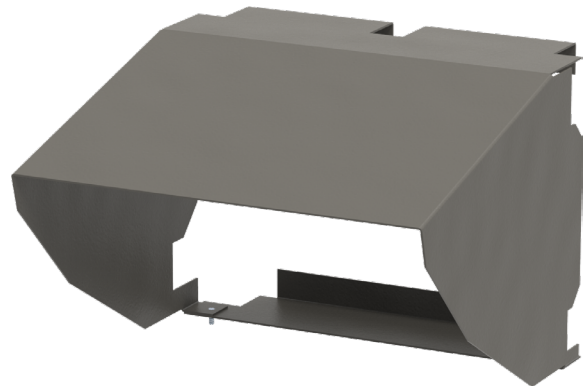

HD/WPLO

OPEN FACE WALL PACK

OUTDOOR

FACTORY SELECT COLOR GUIDE

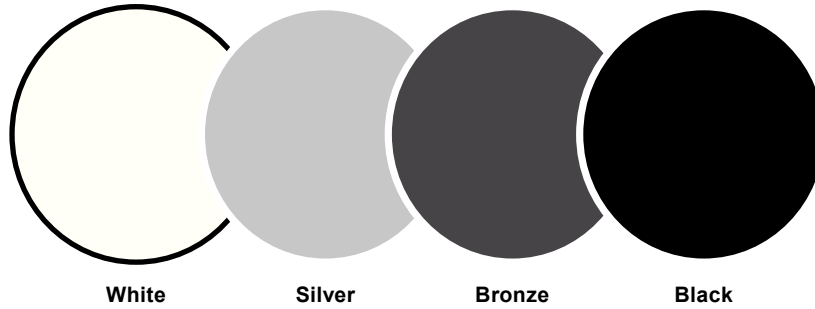

COLOR NAME AND DESCRIPTION		SHEEN	PRICING
WHT	- ILP White	SEMI GLOSS	Consult Factory
SLV	- ILP Silver - Ultrasonic Chrome	GLOSS	Consult Factory
BRZ	- ILP Bronze	SEMI GLOSS	Standard
BLK	- ILP Black	SEMI GLOSS	Consult Factory

COLORS SHOWN ABOVE ARE TO BE USED AS REFERENCE, NOT EXACT MATCH. PLEASE REQUEST PAINT CHIPS FOR EXACT MATCH.

PHOTOMETRIC DATA

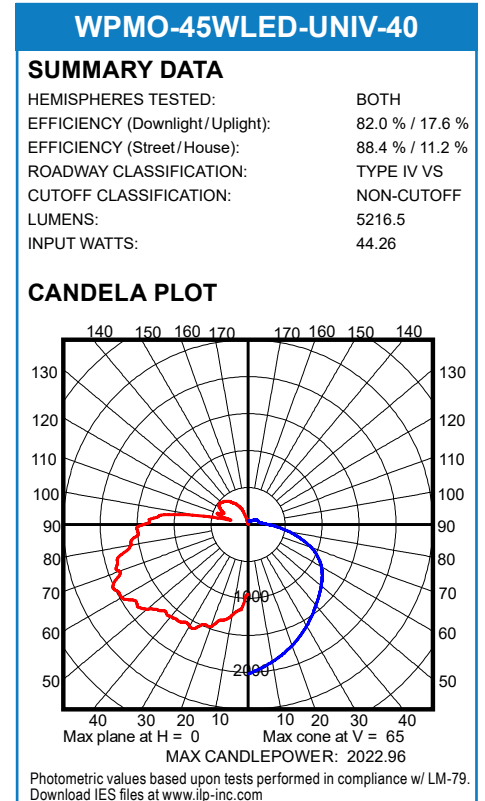
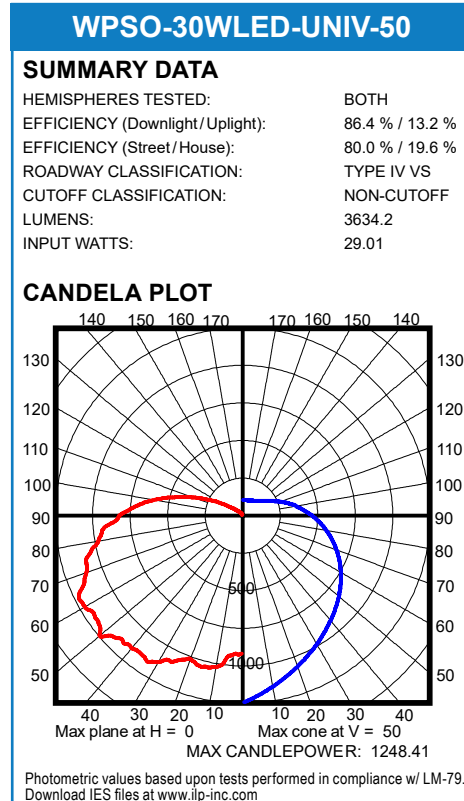
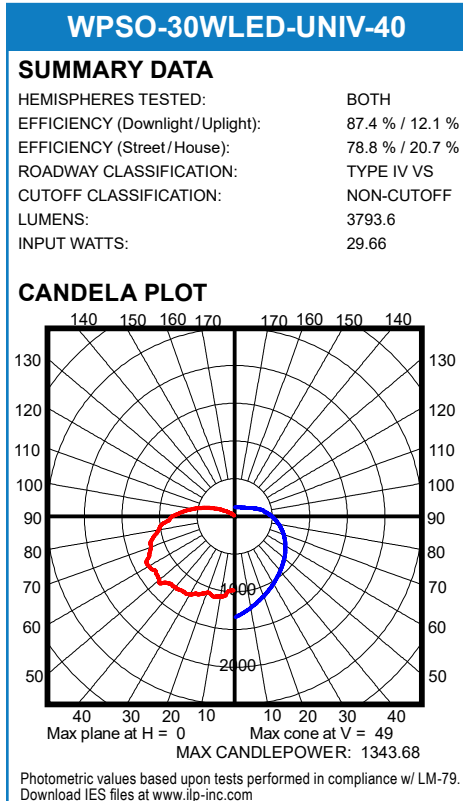

OPEN FACE WALL PACK

OUTDOOR

PHOTOMETRIC DATA

WPMO-45WLED-UNIV-50

SUMMARY DATA

HEMISPHERES TESTED:	BOTH
EFFICIENCY (Downlight/Uplight):	79.1 % / 20.3 %
EFFICIENCY (Street/House):	87.6 % / 11.7 %
ROADWAY CLASSIFICATION:	TYPE IV VS
CUTOFF CLASSIFICATION:	NON-CUTOFF
LUMENS:	5223.3
INPUT WATTS:	44.02

CANDELA PLOT

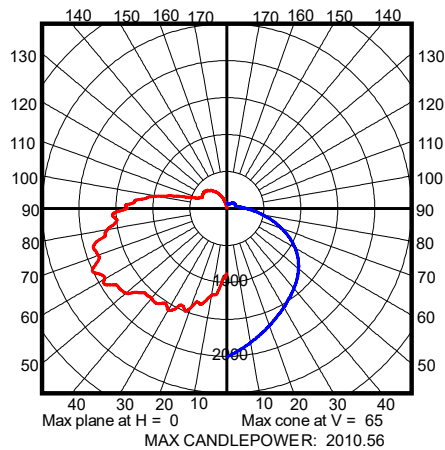

Photometric values based upon tests performed in compliance w/ LM-79.
Download IES files at www.ilp-inc.com

WPMO-70WLED-UNIV-40

SUMMARY DATA

HEMISPHERES TESTED:	BOTH
EFFICIENCY (Downlight/Uplight):	82.2 % / 17.4 %
EFFICIENCY (Street/House):	88.2 % / 11.4 %
ROADWAY CLASSIFICATION:	TYPE IV VS
CUTOFF CLASSIFICATION:	NON-CUTOFF
LUMENS:	7976.9
INPUT WATTS:	66.73

CANDELA PLOT

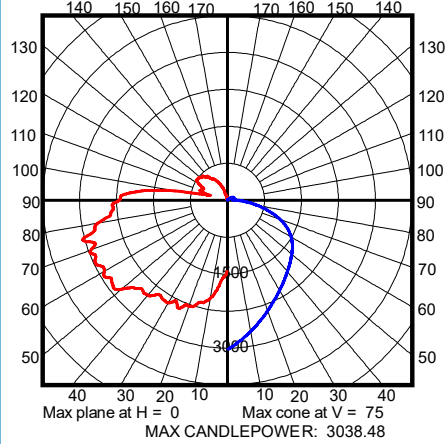

Photometric values based upon tests performed in compliance w/ LM-79.
Download IES files at www.ilp-inc.com

WPMO-70WLED-UNIV-50

SUMMARY DATA

HEMISPHERES TESTED:	BOTH
EFFICIENCY (Downlight/Uplight):	79.9 % / 19.3 %
EFFICIENCY (Street/House):	87.1 % / 12.1 %
ROADWAY CLASSIFICATION:	TYPE IV VS
CUTOFF CLASSIFICATION:	NON-CUTOFF
LUMENS:	7773.3
INPUT WATTS:	67.9

CANDELA PLOT

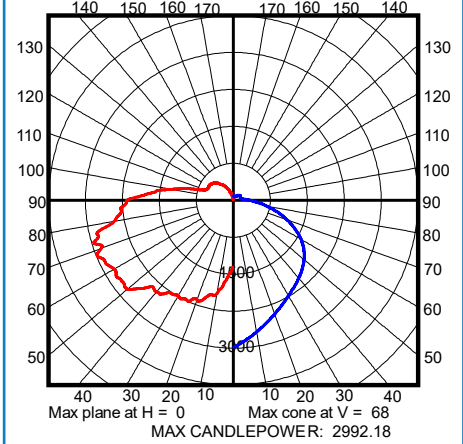

Photometric values based upon tests performed in compliance w/ LM-79.
Download IES files at www.ilp-inc.com

WPLO-90WLED-UNIV-40

SUMMARY DATA

HEMISPHERES TESTED:	BOTH
EFFICIENCY (Downlight/Uplight):	87.3 % / 12.5 %
EFFICIENCY (Street/House):	80.6 % / 19.2 %
ROADWAY CLASSIFICATION:	TYPE IV VS
CUTOFF CLASSIFICATION:	NON-CUTOFF
LUMENS:	10935
INPUT WATTS:	88.12

CANDELA PLOT

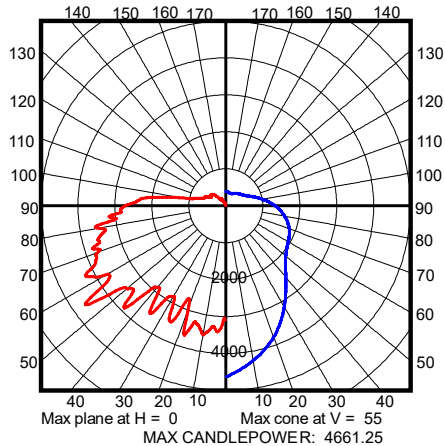

Photometric values based upon tests performed in compliance w/ LM-79.
Download IES files at www.ilp-inc.com

WPLO-90WLED-UNIV-50

SUMMARY DATA

HEMISPHERES TESTED:	BOTH
EFFICIENCY (Downlight/Uplight):	72.2 % / 17.3 %
EFFICIENCY (Street/House):	76.1 % / 13.5 %
ROADWAY CLASSIFICATION:	TYPE IV VS
CUTOFF CLASSIFICATION:	NON-CUTOFF
LUMENS:	10159.6
INPUT WATTS:	86.93

CANDELA PLOT

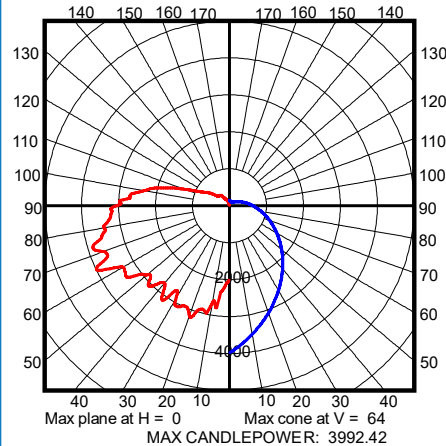

Photometric values based upon tests performed in compliance w/ LM-79.
Download IES files at www.ilp-inc.com

WPLO-135WLED-UNIV-40

SUMMARY DATA

HEMISPHERES TESTED:	BOTH
EFFICIENCY (Downlight/Uplight):	86.7 % / 13.1 %
EFFICIENCY (Street/House):	81.5 % / 18.3 %
ROADWAY CLASSIFICATION:	TYPE IV VS
CUTOFF CLASSIFICATION:	NON-CUTOFF
LUMENS:	15693
INPUT WATTS:	130.81

CANDELA PLOT

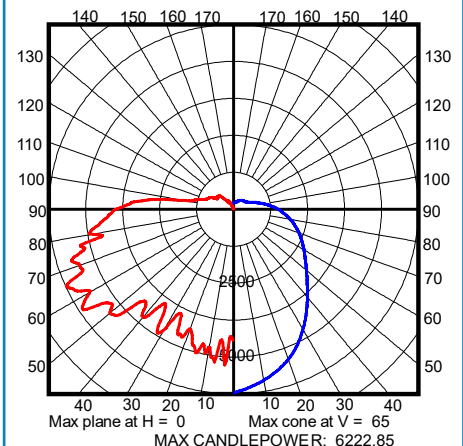

Photometric values based upon tests performed in compliance w/ LM-79.
Download IES files at www.ilp-inc.com

OPEN FACE WALL PACK

OUTDOOR

PHOTOMETRIC DATA

WPLO-135WLED-UNIV-50

SUMMARY DATA

HEMISPHERES TESTED:	BOTH
EFFICIENCY (Downlight / Uplight):	84.3 % / 15.0 %
EFFICIENCY (Street / House):	80.9 % / 18.4 %
ROADWAY CLASSIFICATION:	TYPE IV VS
CUTOFF CLASSIFICATION:	NON-CUTOFF
LUMENS:	15654.4
INPUT WATTS:	132.19

CANDELA PLOT

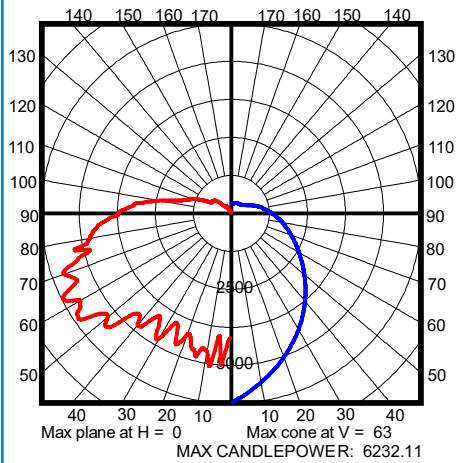

Photometric values based upon tests performed in compliance w/ LM-79.
Download IES files at www.ilp-inc.com

Project Name:	Part Number:	Type:
---------------	--------------	-------

UFO PARKING GARAGE

OUTDOOR



407-478-3759
www.ilp-inc.com

FEATURES

- Low profile die-cast aluminum housing
- Factory Select Finishes: Bronze (BRZ), Black (BLK), Silver (SLV), and White (WHT)
- Custom colors finishes available¹
- Frosted Polycarbonate Lens (std.)
- T5 Wide distribution standard; Optional T5 narrow lowbay optic (LB) (concentrated distribution for atrium or exit/egress applications)
- Up to 10% uplight standard eliminates cave effect
- Mounting: Quick surface mount bracket (std.), 1/2" pendant (std.), or optional trunnion mount bracket
- Four 1/2" coin plugs on sides for conduit or photocell
- 120-277V Universal Voltage or 347-480V High Voltage
- 0-10V Dimmable Driver (std.)
- Battery backup & cold weather battery options available
- PIR Occupancy, Photocell & Bi-Level Dimming sensors available
- Wireless control integrated luminaire
- 3000K, 4000K & 5000K CCT
- >80 Color Rendering Index (CRI)
- Calculated L70 >100,000 hrs @ 25°C per TM-21-11
- IP66 Rated Luminaire
- 5 Year Warranty (std); 10 Year Warranty Optional
- ETL Listed for Wet Locations
- DesignLights Consortium® Premium Qualified Luminaire



¹Contact factory for pricing and availability



SUITABLE APPLICATIONS

- Parking Garages
- Low Bay
- Canopies
- Entrance Way

ORDERING GUIDE:

SERIES	WATTS	DRIVER	CCT	DISTRIBUTION	MOUNTING	FINISH ⁴
UFO UFO Parking Garage	28WLED	UNIV 120-277V	50	BLANK - Wide	BLANK ³ Surface Mount	BLANK Bronze
	40WLED	HV ^{1,2,9} 347-480V	40	LB - Narrow	PEN ^{5,8} 60" leads for Pendant Mounting	BLK Black
	58WLED		30		SCON ³ Side Conduit	SLV Silver
	75WLED					WHT White
BLANK	5 year					CC Custom Color
10YR ^{13,14}	10 year					

OPTIONS	CONTROLS
Factory Installed	BASIC - Factory Installed
DIM ⁵ DIM Leads pulled from unit for external signal	USBD ¹¹ Bluetooth User Select Bi-Level Dim Occ. Sensor
CORD/6FT 6ft 3-Conductor Cord without plug (120-277V)	BDXX Preset Bi-Level Dim Sensor (xx=% ex: 20,30)
CORD/10FT 10ft 3-Conductor Cord without plug (120-277V)	BDXXPC Preset Bi-Level Dim Sensor w/ photocell (xx=% ex: 20,30)
SP1 ^{6,7} 10KA Max Univolt Surge Protector	WLOS PIR Occupancy Sensor
SP2 ^{6,7} 22KA Max Univolt Surge Protector	
SP480V2 ^{2,7} 20kA Max 347-480V Surge Protector	
FUSE/SXXX Single-line Voltage Fuse (120, 277 or 347V)	ADVANCED - Factory Installed
FUSE/DXXX Dual-line Voltage Fuse (208, 240 or 480V)	SU/5S/LR/IL ^{2,6} Enlighted 5S Individual Lighting (IL) Sensor with Control Unit
FI/ILBCP05 ^{2,6} 5W LED (32°F-104°F)	SU/5S/LR/CL ^{2,6} Enlighted 5S Connected Lighting (CL) Sensor with Control Unit
FI/ILBCP05/HE ^{2,6} 5W 120-277V LED High Efficacy CEC Title 20 Battery Backup (32°F-104°F)	SU/5S/LR/IOT ^{2,6} Enlighted 5S Internet of Things (IOT) Sensor with Control Unit
LEDBB ^{2,6} 16W 120-277V LED Battery Backup (32°-104°F)	LPL/INT ^{2,6} Limelight by Lutron Wireless Control System w/ Sensor (8-15ft)
LEDBBCT ^{2,6} 14W UNIV CT Battery backup (-4°F-104°F)	LPM/INT ^{2,6} Limelight by Lutron Wireless Control System w/ Sensor (15-30ft)
LEDBBCT7 ^{2,6} 10W UNIV CT Battery backup (-4°F-104°F)	IRTEC/W/B ^{2,6,12} IR-TEC OS-NET Wireless Control System w/ Sensor
SMLxxxx Specified Lumen Output (xxxx = lumen output)	
SD347 ^{1,6,9} 347V Step Down Transformer	
SD480 ^{1,6,9} 480V Step Down Transformer	
Ship with Accessories	Ship with Accessories
SRP/281 IR-TEC OS-NET Remote Sensor Configuration Tool	PCU ^{2,6} Electronic UNIV Photocell (120-277V)
BCS Bird Cone Shield (Pendant Mount Only)	
TB Trunnion Mount Bracket	

¹ Does not qualify for DLC

² Not available with SD347 or SD480 options

³ 3 conductors provided, for 5 conductors for external signal select "DIM" option

⁴ Bronze, Black, Silver & White finishes are standard.

Consult factory for pricing & availability of other finishes; subject to longer lead times

⁵ Equivalent length of power leads

⁶ Not available with HV option

⁷ SP1/SP2 specified in combination w/ battery backups,

separate surge protectors are required per electrical line

⁸ Pendant provided by others

⁹ Not available in 28WLED Model

¹¹ Requires bluetooth enabled device for programming (provided by others)

¹² Requires SRP/281 to program

¹³ Contact Factory for more details

¹⁴ Requires additional surge protection (SP1, SP2, SP480V2); For additional details see general terms and conditions

UFO PARKING GARAGE

OUTDOOR

LED SYSTEMS INFORMATION ¹		3000K			4000K			5000K			Max Ambient	Watts ²	Replaces
Part Numbers	Distribution	Lumens	Efficacy	DLC ³	Lumens	Efficacy	DLC ³	Lumens	Efficacy	DLC ³			
UFO-28WLED	Wide	3,245 lm	117 lm/W	PRM	3,450 lm	124 lm/W	PRM	3,462 lm	126 lm/W	PRM	125° F	27 W	150W MH
	LB	3,584 lm	135 lm/W	PRM	3,819 lm	144 lm/W	PRM	3,864 lm	146 lm/W	PRM	145° F		
UFO-40WLED	Wide	4,702 lm	112 lm/W	STD	4,985 lm	118 lm/W	STD	5,014 lm	119 lm/W	STD	110° F	40 W	150W MH
	LB	5,250 lm	131 lm/W	STD	5,567 lm	139 lm/W	STD	5,610 lm	140 lm/W	STD	125° F		
UFO-58WLED	Wide	7,210 lm	125 lm/W	PRM	7,135 lm	125 lm/W	PRM	7,171 lm	126 lm/W	PRM	130° F	57 W	175W MH
	LB	7,288 lm	127 lm/W	PRM	7,260 lm	126 lm/W	PRM	7,297 lm	127 lm/W	PRM	130° F		
UFO-75WLED	Wide	9,310 lm	121 lm/W	STD	9,266 lm	121 lm/W	STD	9,275 lm	123 lm/W	STD	125° F	76 W	250W MH
	LB	9,546 lm	125 lm/W	STD	9,482 lm	124 lm/W	STD	9,640 lm	126 lm/W	STD	125° F		

¹Values are nominal, see IES file for more detail

²Electrical data at 25C (77F). Actual wattage may differ by +/-10%.

³Please be sure to check DLC website for updates and current listing

SPECIFICATIONS

CONSTRUCTION

The UFO Parking Garage and Canopy luminaire features a rugged low-profile die-cast aluminum housing with a durable Bronze or White polyester powder coat finish to withstand extreme weather changes without cracking or peeling. Alternate standard or custom finishes are wet painted over the bronze powder coat (Consult Factory). The UV stabilized and impact resistant diffuse polycarbonate lenses are designed to provide maximum rigidity and optical transmissions up to 92%. The lenses seal to the housing with a one-piece gasket creating an IP66 rating for maximum ingress protection. An integral galvanized hinged quick surface mount bracket is provided for ease of installation.

ELECTRICAL

High-performance driver features over-voltage, under-voltage, short circuit and over temperature protection. 0-10V dimming (10% - 100%) standard. Standard Universal Voltage (120-277 Vac) Input 50/60 Hz or optional High Voltage (347-480 Vac). L70 >100,000 hrs. in accordance of IESNA TM-21-11 Projected values at 25°C Ambient temperature. Total harmonic distortion: <20%. Power factor: >0.90. Input power stays constant over life. Minimum 6kV surge rating meets a minimum Category C Low operation (per ANSI/IEEE C62.41.2). Additional protection is available in 10kV and 20kV options. Optional 120-277V standard, CEC Title 20 compliant, and Cold Temp Battery backups are available. The 90-minute batteries provide constant power to the LED system, ensuring code compliance and a test switch/indicator button is installed on the housing for ease of maintenance.

INSTALLATION

The UFO features an integral quick surface mount bracket, eliminating the need to open the luminaire during installation to the Junction box or ceiling surface resulting in IP66 ingress protection that is effortless and secure. Four ½" conduit entry points allow for surface-conduit wiring. The UFO can be pendant mounted with ½" pendant stems (provided by others). Trunnion mounting available with 14"-22" adjustability. For surface mount applications the 12" 3-conductor fixture leads exit the back of the casting through a water-tight connector. For pendant applications 60" 3-conductor leads are provided unless otherwise specified. For Trunnion mount a 3-conductor 60" outdoor cable is provided with cord grip. For 5-conductor leads for control via external signal "DIM" must be specified.

WARRANTY

5 Year Warranty Standard; 10 Year Warranty Optional ([Terms and Conditions apply](#)).

OPTICS

The UFO ships standard with a diffuse polycarbonate lens that virtually eliminates glare and optimizes the delivered light for maximum visual comfort and uniformity. While its curved LED board with densely populated mid-power LEDs, eliminates pixilation and provides up to 10% uplight (Std.) to eliminate cave effect. The UFO is available with a T5 wide distribution or Optional T5 narrow lowbay optic (LB) (concentrated distribution for atrium, lowbay, or exit/egress applications. Available in 3000K, 4000K or 5000K color temperature (CCT) per ANSI C78.377. Consult factory for availability of alternate CCTs.

THERMAL

The UFO features an array of High-efficacy mid-power LED's on a curved LED board that is mounted directly to a cast aluminum housing with heat dissipating fins to provide excellent thermal performance extending the life of electronic components. Operating Ambient Temperature: See table on page 2.

CONTROLS

Standalone Controls: Four ½" NPT apertures allow for field installed 120-277V universal electronic pencil photocells. Optional PIR sensors available installed directly in the center of the housing door. Sensors provide optional on/off control, photocell capability, bi-level dimming, and bluetooth configuration allows for onsite modifications.

Wireless Control Systems: The UFO is wireless mesh controls ready with IR-TEC, Enlighted, and Lutron Limelight wireless control platforms. Available with and without PIR sensors. Inquire with factory for more information or for additional controls options, including customer supplied items.

CERTIFICATIONS

UL Listed for wet locations. DesignLights Consortium® (DLC) Premium qualified product and DLC qualified product. Not all versions of this product may be DLC Premium qualified or DLC qualified. Please check the DLC Qualified Products List at www.designlights.org/QPL to confirm which versions are qualified. Title 24 Compliant with select options; see local ordinance for qualification information.

UFO PARKING GARAGE

OUTDOOR

LINE DRAWINGS

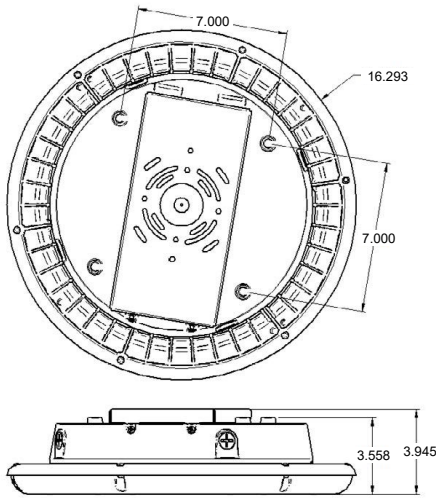

Bird Cone Shield

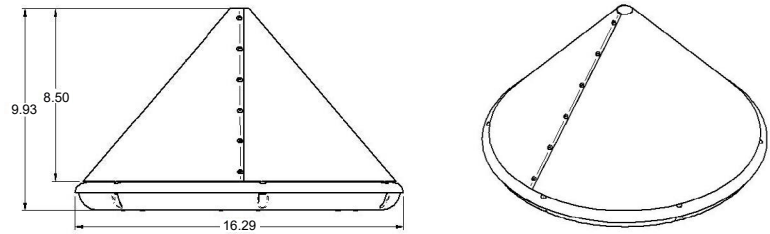

MOUNTING OPTIONS

- **Quick Mount Bracket** - Standard base of installation when surface mounting to either the ceiling or junction box
- **Pendant** - 1/2" threaded pendant can be mounted through 1/2" coin plug on top of fixture (Supplied by other)
- **TB** - Trunnion Mount Bracket

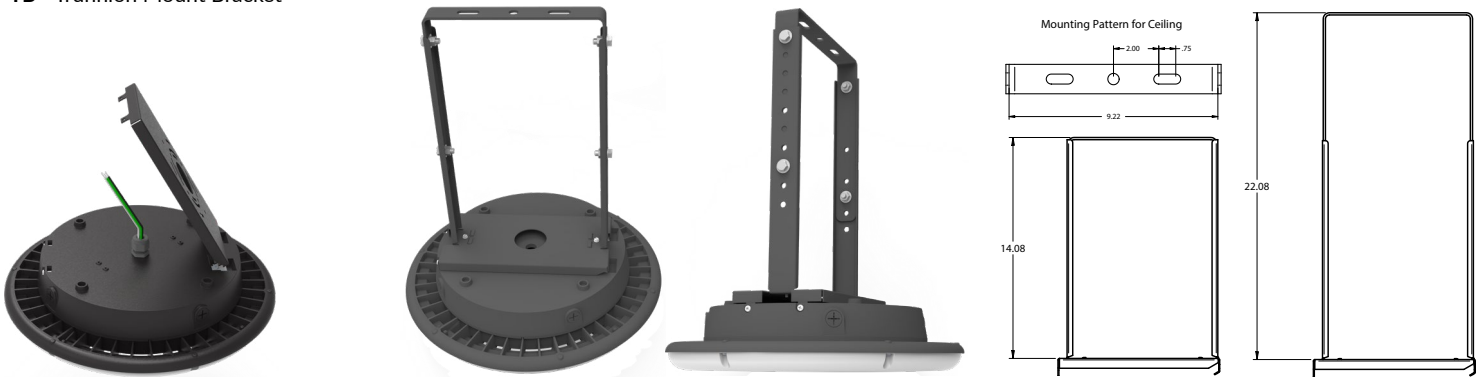

Quick Mount Bracket

Trunnion Mount Bracket

FACTORY SELECT FINISH GUIDE

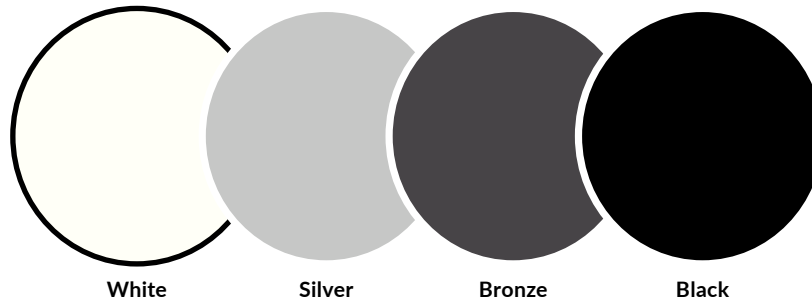

White

Silver

Bronze

Black

COLOR NAME AND DESCRIPTION		SHEEN	PRICING
WHT	- ILP White	SEMI GLOSS	Standard
SLV	- ILP Silver - Ultrasonic Chrome	GLOSS	Standard
BRZ	- ILP Bronze	SEMI GLOSS	Standard
BLK	- ILP Black	SEMI GLOSS	Standard

COLORS SHOWN ABOVE ARE TO BE USED AS REFERENCE, NOT EXACT MATCH. PLEASE REQUEST PAINT CHIPS FOR EXACT MATCH.

UFO PARKING GARAGE

OUTDOOR

PHOTOMETRIC REPORT

40W

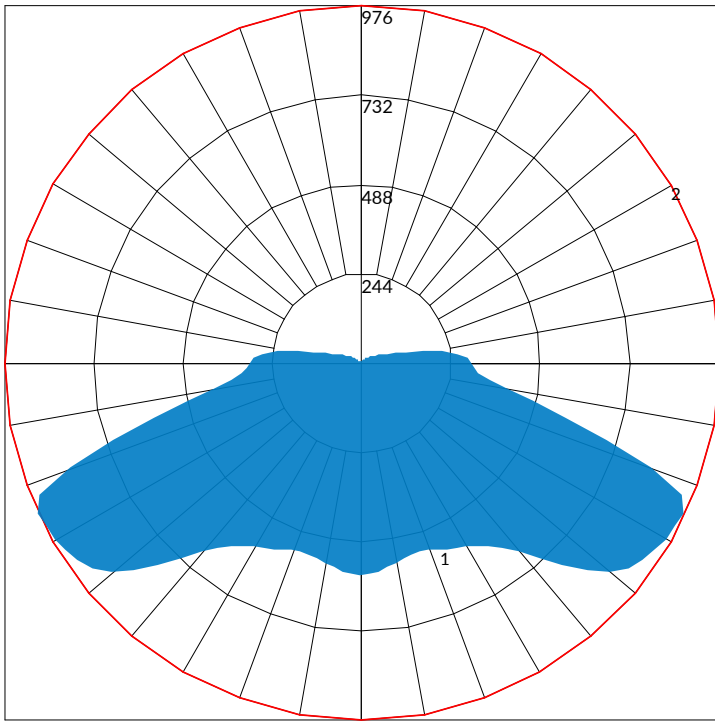

Maximum Candela = 976.3 Located At Horizontal Angle = 0, Vertical Angle = 65
 # 1 - Vertical Plane Through Horizontal Angles (0 - 180) (Through Max. Cd.)
 # 2 - Horizontal Cone Through Vertical Angle (65) (Through Max. Cd.)

40W LB

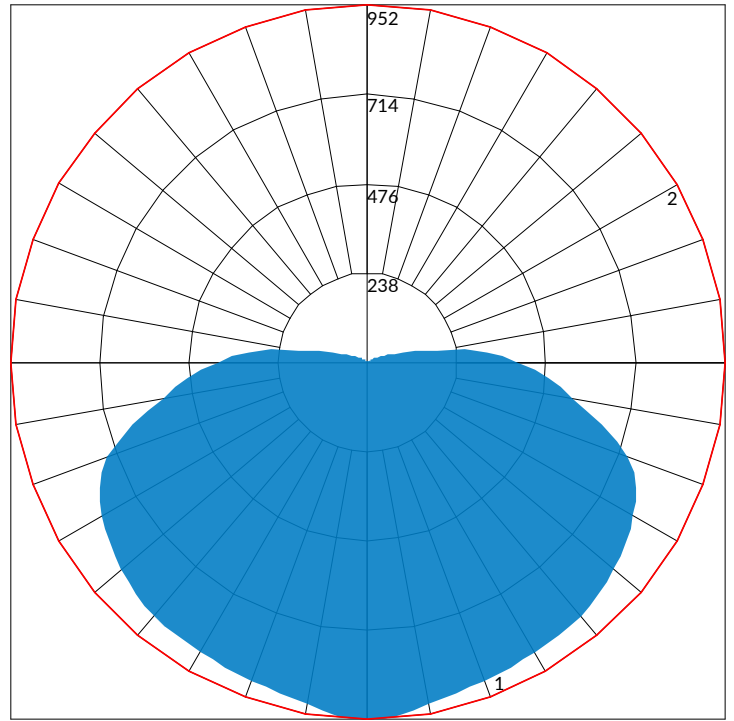

Maximum Candela = 951.9 Located At Horizontal Angle = 0, Vertical Angle = 0
 # 1 - Vertical Plane Through Horizontal Angles (0 - 180) (Through Max. Cd.)
 # 2 - Horizontal Cone Through Vertical Angle (0) (Through Max. Cd.)

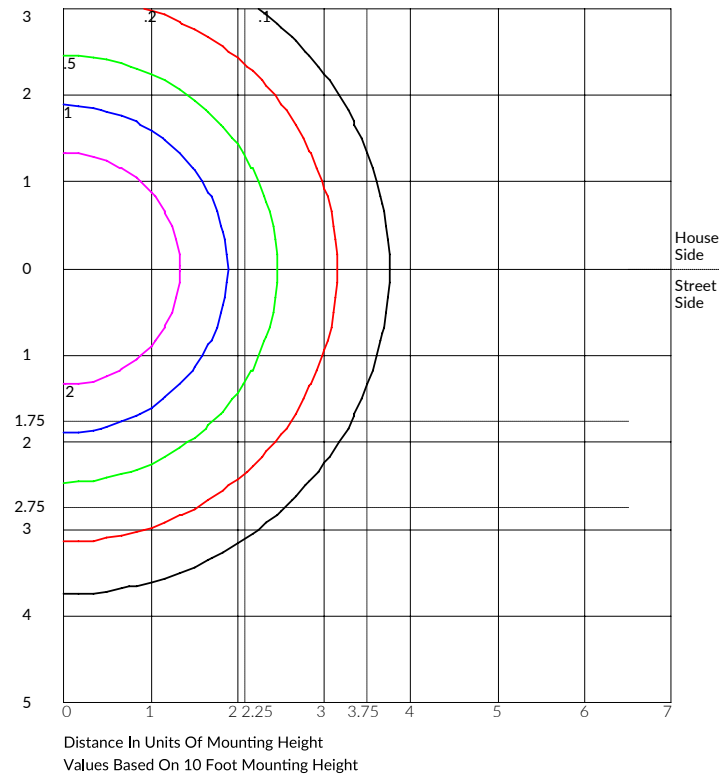

Distance In Units Of Mounting Height
 Values Based On 10 Foot Mounting Height

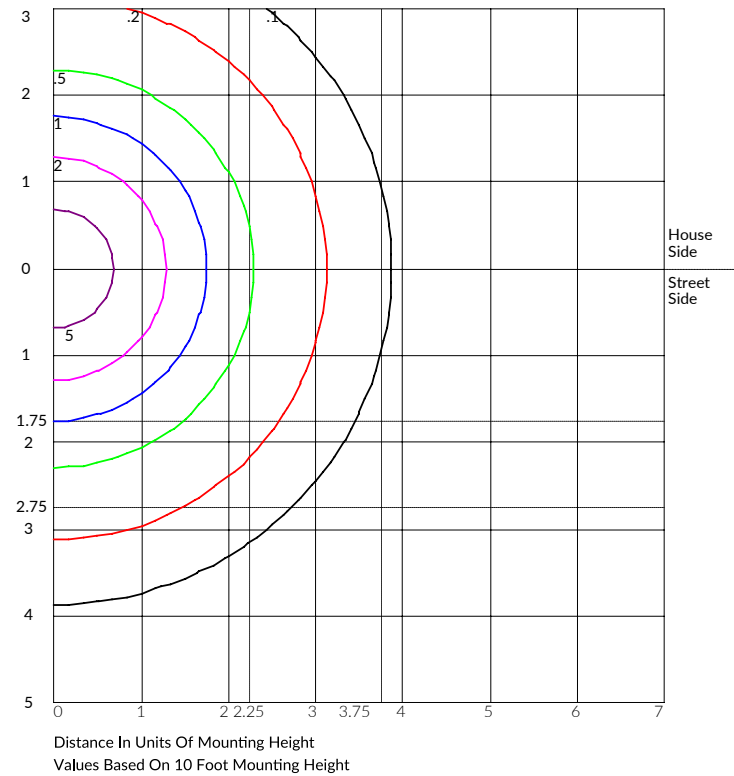

Distance In Units Of Mounting Height
 Values Based On 10 Foot Mounting Height