



McAuliffe Middle School

A National Blue Ribbon School
A California Distinguished School
A California Gold Ribbon School

4112 Cerritos Avenue
Los Alamitos, California 90720
School Office: (714) 816-3320
Absence Line: (714) 816-3352
FAX: (714) 816-3362

CONNECT WITH US

		
ONLINE losal.org/mcauliffe	TWITTER @McAuliffe_Eagle	INSTAGRAM @mcauliffe_middle_school

“Be yourself, try your best, and never be afraid to dream.”

Sharon Christa McAuliffe

Student Handbook 2021-2022

This planner belongs to:

Name: _____

Address: _____

City: _____ **Zip:** _____

Telephone: _____

Find Your Locker

Athletic Fields

Basketball Courts

Basketball Courts

Tennis Courts

Locker Number			
By Building	A	B	C
1001-1126	2001-2209	4001-4167	
2210-2471	4168-4253		
	4254-4447		
	4448-4547		

53	52 - Outpost Sign-In/Out
Enter	Enter
<<<<<<	<<<<<<
>>>>>>	>>>>>>
Exit	Exit

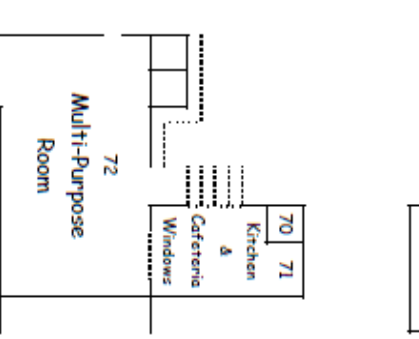
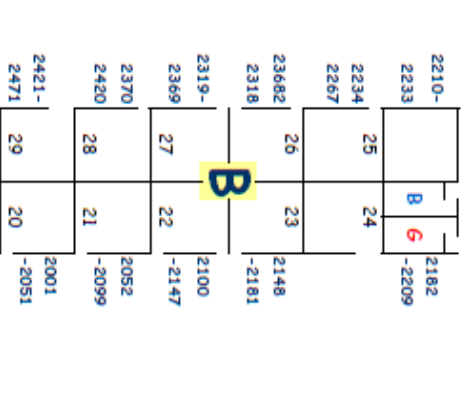
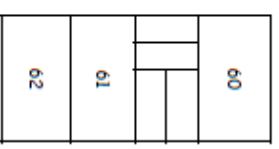
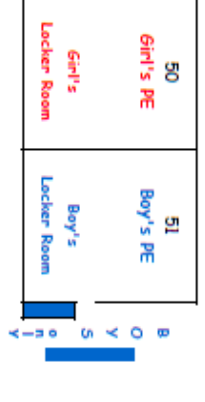
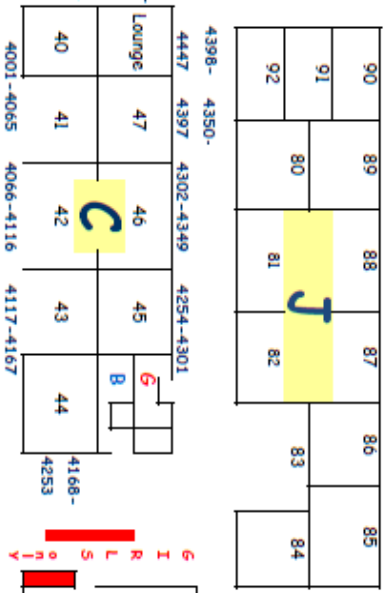
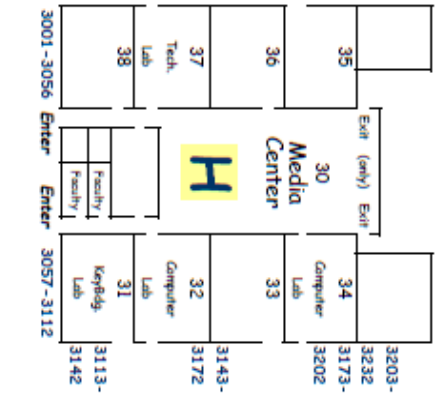

McAuliffe Middle School
 4112 Cerritos Avenue
 Los Alamitos, CA 90720
 714-816-3320

C E R R I T O S A V E N U E

S T R E E T



Exit >>>>> Exit



Enter <<<<<< Enter

McAuliffe Middle School Eagles

The vision for McAuliffe is to educate all students intellectually, socially, and physically in a safe nurturing environment, to produce citizens with an appreciation and respect for learning and democratic ideals, and to cultivate citizens who will celebrate the diversity of all cultures.

Table of Contents

WELCOME TO MCAULIFFE		Hall Passes.....	7
Visitor's Pass	1	Student Personal Property.....	7
ATTENDANCE	1	Cellphones.....	7
Traveling To and From School	1	Library / Media Center.....	7
Attendance	1	SCHOOL RULES AND DISCIPLINE (cont.)	
Tardy Policy.....	1	Care of Textbook.....	7
Truancy.....	1	Lunch / Cafeteria Rules	7
Homework Requests	1	Food/Food Allergies	7/8
Leaving School.....	2	Gum.....	8
HEALTH / EMERGENCY INFORMATION	2	Candy	8
Health Office.....	2	Dress Code.....	8
Medication/Lice.....	2	Familiarity	8
Illness At School.....	3	Profanity	8
Office Telephone Use.....	3	Gambling	9
Emergency Cards.....	3	Cheating.....	9
Accidents.....	3	Care of Property	9
Drills.....	4	Harassment	9
Fire/Earthquake/Major Disaster/Lockdown.....	4	Bullying.....	9
Intruder Protocol.....	4	Detention.....	9
ID Cards.....	4	Saturday School	9
STUDENT MATERIALS	4	Suspension / Expulsion	9
GRADES AND CITIZENSHIP	4	Expulsion on the 1 st Offense.....	10
Report Cards	4	Bicycles / Bike Helmets	10
Failing Grades / Retention	4	Skateboards, etc.....	10
Promotion to Ninth Grade.....	5	Bus Regulations	10
Citizenship Expectations	5	Deliveries.....	10
Activities.....	5	Lockers.....	10
STUDENT ACTIVITIES	5	Locker Problems.....	10
Bulletin.....	5	Locker Rules.....	10
Intramural Sports	5	Lost and Found.....	11
Assemblies	5	Parent Involvement.....	11
Student Government	5	State Assessments.....	11
STUDENT RECOGNITION	6	Demerit System	11
Eagle Express Cards	6	Academic Honesty Code.....	11
Citizenship Club.....	6	Cheating.....	11
Honor Roll.....	6	You Are Cheating If	12
Principal's Honor Roll	6	PARKING	12
Student of the Month	6	BELL SCHEDULES	13
Eighth-Grade Award Night.....	6	IMPORTANT DATES	14
Birthdays.....	6	SCHOOL STAFF	15
SCHOOL RULES AND DISCIPLINE	6		
Discipline Philosophy and Policy	6		
General School Rules.....	6		
Clean Campus.....	6		
Conduct To and From School.....	6		
Drug Detection Canine	6		
Voluntary Drug Testing.....	6		



WELCOME TO MCAULIFFE

Welcome to McAuliffe! McAuliffe is your school and we want you to enjoy your time here! Enclosed in this handbook are the guidelines that will help you be successful!

VISITOR'S PASS

Parents or guardians of our students are encouraged to visit our school and observe our educational program. **ALL VISITORS MUST CHECK IN AT THE MAIN OFFICE. Please arrange all visitations in advance with administration. We do not allow students from other schools to visit us during the school day or during various activities.**

ATTENDANCE

TRAVELING TO AND FROM SCHOOL

Students are to go directly to and from school without loitering. Once a student is on our campus, he/she is not to leave. Students dropped off by parents are to immediately enter through the gates and may not leave.

Appropriate conduct, before and after school, while waiting for parents, or at the bus stop is expected. Students are accountable for their behavior as they travel to and from school.

ATTENDANCE

Regular attendance is essential to successful school performance. Please make every effort to attend school every day unless your student is ill.

When students are absent from school, the parent/guardian is **required** to call the Attendance Office within 3 days of absence at (714) 816-3352. (This telephone number is an answering machine and operates 24 hours a day, 7 days a week.) If no call is made, a note verifying the absence IS REQUIRED and should be brought to the Attendance Office BEFORE SCHOOL BEGINS ON THE FIRST DAY BACK FROM THE ABSENCE. If a student is absent more than 3 consecutive days, a doctor's note is mandatory to return to school. Absences will be considered unexcused if they have not been cleared within three school days.

The ONLY excused absences are those resulting from illness, medical/dental appointment, or death in the immediate family. ALL OTHER ABSENCES ARE CONSIDERED UNEXCUSED. Teachers are not required to provide homework, extend deadlines, or allow makeup work for students with unexcused absences.

TARDY POLICY

Students are expected to be on time to school. If a student is more than 5 minutes late to school, he/she **MUST SIGN IN AT THE ATTENDANCE OFFICE.** Students who are late fewer than 5 minutes may go directly to class and will be marked tardy by teacher.

Tardiness is excused for illness and for medical/dental appointments. **Oversleeping, missing the bus, traffic and completing homework are not considered valid reasons for excused tardies.** Tardiness applies before school, between classes, and after lunch. Tardies not verified or tardies without a valid reason are cause for student detention.

TRUANCY

According to the Education Code of the State of California, any pupil who is absent from school without valid excuse, or tardy in excess of 30 minutes on each of more than three days in one school year, is truant and shall be reported to the administration. Students who are truant are assigned detention or Saturday School. The following are considered trancies:

- Being absent from school without the knowledge and consent of the parent.
- Leaving the school grounds during the day without permission.
- Staying out of class without permission.

HOMEWORK REQUESTS

Students are given the opportunity to make up schoolwork missed because of excused absences. Full credit is given if the work is returned promptly to the teacher. Students are allowed one day of make-up time for every day that the student was absent from school due to illness. It is the responsibility of the student to get make-up work from his/her teachers upon returning to school, or a parent may request homework on the fourth day of absence by calling the Attendance Office before 9:00 a.m. If absent less than three days, the student may keep up with assignments by calling a "Homework Buddy" or checking with our online service (ABI). If you need assistance with our online service, please contact the registrar in main office.

LEAVING SCHOOL

Off-Campus Procedures:

Bring a note to the attendance office before school.

1. Parent to sign student out in the attendance office at time of leaving.
2. Student will be called from class with a release slip.
3. Check in with the attendance with release slip office upon returning. *If you want your student in the office at a designated time prior to your arrival, please be sure the attendance office has a note with the student's name, reason for leaving and time needed to meet you in the office PRIOR to school starting. We cannot guarantee that a student can be pulled from class prior to your arrival unless you send the note prior to the start of the school day. *A phone call prior to pick up doesn't guarantee student will be waiting for parent pick up in office.*

Don't forget to bring a note to the attendance office before Period 1 (8:45 a.m.) to get your off-campus permit.

Students may not be released to anyone other than those indicated on the ONLINE Emergency Contacts. This is for the protection of the students and contacts need to be added in the AERIES portal by parent.

HEALTH AND EMERGENCY INFORMATION

HEALTH OFFICE

The Health Office is located in the Main Office building. If a student becomes ill during school hours, he/she is to ask his/her current teacher for a Hall Pass to the Health Office. If an injury occurs after a student arrives at school, he/she is to contact an adult for assistance.

HEALTH – Students who appear ill or have a rash should not be sent to school. If a child has had a fever, they should be kept home for at least 24 hours after the temperature has returned to normal. Students who become ill or injured at school will be isolated from others as soon as the accident or illness is noted. Your child will be sent home from school if they have a fever while at school. In case of accident or illness at school, a qualified person will administer first aid and the parents will be notified. Except for first aid at the time of a school injury, the health office staff cannot treat chronic or severe injuries. If it is necessary for a student to go home because of an illness or injury, it will be the responsibility of the parent or guardian to pick up the child from school as soon as possible. In the case of long-term medical problems, a credentialed school nurse (CSN) is available to coordinate the support of students with chronic or long-term health issues. The CSN also arranges for hearing and vision screening necessary for the health of all children. These state mandated screenings are scheduled periodically throughout the year for designated grade levels. The credentialed school nurse also serves as a consultant to parents, teachers and administrators in regards to the health needs of the children

MEDICATION – The following information related to the administration of medication in the Los Alamitos Unified School District in accordance with California Education Code (Sec. 49423).

Medical treatment is the responsibility of the parent and the physician. Medications are rarely given in school. The only exceptions involve special or serious problems where it is deemed absolutely necessary to give the medication during school hours, and where it is not possible for the parent to administer it to their child. Consequently, the parent is urged, with the help of the physician, to work out a schedule of giving medication outside school hours. The school nurse serves all the district schools and is not available every day to administer medication to every child who must receive it. Therefore, the school office staff (clerks, secretary, or principal) might be the person to administer it. They cannot be expected to assume this responsibility unless it is necessary.

*****All medications must be kept in the Health Office. This includes over-the-counter medication such as aspirin and cough drops. No medication will be dispensed without proper release forms that can be obtained from the office.**

In order for school staff to administer any medication (prescription or over-the-counter) to any student, specific orders must be written and signed by your child's physician on the "Physician's Request for Administration of Medication" form which is available at the school or on-line. This request must clearly specify the name of the medication, the reason for the medication, dose to be given, and the time it is to be administered. Whenever the medication, the dosage, or the time to administer is changed, a new form is required. Additionally, a signed agreement from the parent section (at the top of the page) is also required.

You are strongly advised to teach your child to assume responsibility for coming to the health office to receive the medication at the appropriate time. Medication should be delivered to the school and taken home by the parent or responsible adult. Medication must be in an original prescription container, properly labeled by the pharmacist with the child's name, doctor's name, name of the medication, dosage, time or administration, and route (such as oral, topical or other site for administration). You may request two containers from the pharmacist, one for school and one for home. If a child gets more than one type of medication, each type must be in a separately labeled container. We cannot accept envelopes, zip-lock bags or other types of containers. The parent is responsible for cutting pills in half. Children may not carry their own medications on campus. Please do not send pills, cough syrup, or any other medicine in your child's lunch.

LICE – Head lice do not transmit disease, but they are a nuisance. Parents can find it upsetting to learn that their child or a classmate has become infested with lice, but having head lice is a fairly common problem and has nothing to do with hygiene or good parenting. In fact, good health and hygiene habits or a clean house or school, have nothing to do with getting head lice. If you or your child has head lice, it is important to treat right away. If you discover that your child has head lice, please notify the school health office. If your child has live lice, please do not send them to school. Treat their hair with a pediculicide (products like RID, NIX or Ovide) and notify the school. Your student may attend school after being treated. Ongoing daily nit removal at

home is expected. Home treatment guidelines and resources can be obtained on the California Department of Public Health website :<https://www.cdph.ca.gov/> or from your school health office. Please call the health office if you have any questions or concerns. The Health office will discretely monitor students with a recent case for 1-2 weeks following and until occurrence has cleared.

ILLNESS AT SCHOOL – Any student feeling ill should inform the teacher and ask for a pass to the office. Students feeling weak or faint will be accompanied to the office. If it appears that students are going to require longer than a 15-minute rest, the parents will be contacted and asked to come and pick up their child so they can receive proper care at home under adult supervision. No student will be allowed to remain in school with a fever or any contagious disease. If your student shows symptoms of illness during the night, please keep him/her home from school. Students who stay home at the onset of illness recuperate faster and miss fewer days of school overall. When the body is trying to fight an illness, it is more likely to pick up other germs and remain sick for a longer period of time. Everyone enjoys better health when the number of sick people that others are exposed to is reduced. Throughout the year, students are frequently exposed to upper respiratory infections and other illnesses. Your child should not be sent to school or will be sent home if the following are present:

1. A temperature of 100° or above (orally) or 99° or above (under the arm) within the last 24 hours.
2. Vomiting (2 or more times in a 24-hour period, or with associated fever and illness).
3. Diarrhea when unable to contain watery stools in the toilet until condition resolves. If child wears a diaper must not be in school with watery stools, increased frequency and when associated with fever and behavior changes that indicate illness.
4. Red eyes with purulent (whitish/yellow mucus) eye drainage. A child may return to school when the eyes are clear and/or there is a note from the doctor indicating that the condition is non-infectious or that treatment has begun.
5. A rash. A child may return to school when the rash has cleared or there is a note from the doctor indicating that the condition is not contagious or that appropriate treatment has begun. Some rashes will need to be covered at school even after treatment.
6. Head lice. Request [“Parent Guidelines for Treating Head Lice”](#) from the office . Parents are expected to treat their child’s head the same day, and students will be checked the following day and monitored for 1-2 weeks following or until occurrence has cleared.

If your child complains of feeling ill or seems “not themselves,” please keep them home. You can observe your child and contact your family physician if the symptoms do not subside.

COMMUNICABLE DISEASE CONTROL – Parents are urged to adhere to the California Health and Safety Codes. **IT IS THE RESPONSIBILITY OF THE PARENT TO NOTIFY THE SCHOOL IMMEDIATELY WHEN A COMMUNICABLE DISEASE IS SUSPECTED OR DIAGNOSED.**

This is an important step in the control of disease. Examples of infectious conditions, which should be reported immediately, are head lice, chicken pox, measles, mumps, pertussis and impetigo.

READMISSION FOLLOWING COMMUNICABLE ILLNESS –The school office must clear children before being allowed to re-enter the classroom.

HEALTH SERVICES – The Health Services Department for the Los Alamitos Unified School District consists of two credentialed school nurses (CSN) who share responsibility for all students in the district, and part-time school-based licensed and unlicensed health office staff members. The CSNs oversee the operation of the Health Offices at each school site and work to standardize health practices in the district. They serve as consultants to parents, teachers and administrators concerning the health needs of all students and coordinate state mandated screenings of Hearing and Vision. The screenings are scheduled periodically throughout the year for designated grade levels.

Health office clerks and LVNs maintain current training in CPR and first aid. They take care of health records, medication administration and minor injuries that may occur during school hours. In case of an accident or illness at school, a qualified person, such as the health clerk or the front office staff, will administer first aid and the parents will be notified. Except for first aid at the time of a school injury, the health clerk cannot treat, diagnose or provide on-going medical care for chronic or severe injuries or conditions. Please seek the advice of a medical doctor for this.

If it is necessary for a student to go home because of an illness or injury, it will be the responsibility of the parent or guardian to pick the child up from school as soon as possible.

OFFICE TELEPHONE USE

Students may use a telephone in the office on an as-needed basis.

EMERGENCY CARDS

Every student must have an emergency card filed in the office. If your address or telephone number has changed, please contact the school Registrar in the main office to update the current information. The proper corrections will be made on-line in your student Aeries account by the school Registrar. If a parent or guardian should be out of town, the school must be informed of the temporary guardian. Only those listed on the Emergency contact list may pick up a student from school.

ACCIDENTS

INJURY OR ACCIDENT AT SCHOOL – Every effort is made to provide for your child’s safety and comfort at school. If your child should have an accident or injury at school, first aid will be given

immediately to make the child as comfortable as possible. If an injury is more serious than a simple bruise or scrape, parents will be called. It is, therefore, extremely important that current Emergency Contact phone numbers are up-to-date in Aeries and/or on file in the school office. Please update the school office if this information changes mid-school year. If parents are unavailable in the event of an emergency paramedics will be called.

Every accident in a school building, on the school grounds, at practice sessions, or at any athletic event sponsored by the school must be reported immediately to the person in charge and to the school office.

DRILLS

Drills at regular intervals are required by law and are an important safety precaution. It is essential that when the first signal is given, everyone obeys orders promptly. The teacher in each classroom will give instructions to the students.

FIRE / EARTHQUAKE / MAJOR DISASTER/LOCKDOWN

Stay calm and follow your teacher's instructions. **DO NOT RUSH** outside. When the emergency is over, the teacher will decide when it is safe to evacuate.

Follow instructions. If OUTSIDE, stay in the open. Move away from buildings, trees and wires. **DO NOT RUN**. Correct emergency building exiting procedures are listed near each exit door. Remember, STAY CALM, FOLLOW DIRECTIONS. Should the fire drill, earthquake, or emergency occur before school, between periods, at lunch, or after school, proceed directly to the designated teacher's basketball backtop area:

Before School:	Go to 1 st period teacher's area
Passing Period:	Go to previous teacher's area
Lunch:	Go to previous teacher's area
After School:	If not already on the way home, proceed to backtop area for further instructions

If you are out of class for some reason when such an emergency takes place, report to the teacher whose class you are in at the time. During a drill, there should be no talking, running, or pushing. The last person out should close the door.

LOCKDOWN

Level One: Instruction continues as usual with doors locked. All students moved inside. Attendance reported to the office.

Level Two: Instruction continues. Movement is discouraged and highly supervised. All doors locked. All students moved inside. Attendance reported to the office.

Level Three: All students inside. Doors locked. Lights off. Students are hidden from view. Attendance reported to the office.

INTRUDER PROTOCOL

Evade: Evacuate the premises, assist others, leave belongings behind.

Barricade: Restrict access to your room with furniture and other means, stay out of sight.

Engage: A last resort only when the violent intruder is in your immediate vicinity.

ID CARDS

All students are issued an ID card at the time Fall pictures are taken. Students should always have their ID. It is used as a lunch ticket, bus pass, and is required when using the Internet. Students who misplace their ID are allowed only **3 temporary bus passes**. They then need to purchase a replacement ID which can be purchased for \$5.00 at the Attendance Office.

STUDENT MATERIALS

All middle school students should have the following items with them at school EVERY DAY:

Textbooks – Textbooks will be loaned to students for their use during the school year. They are to be brought to class every day. **Parents should be aware that they are responsible for textbooks given to their students, and will be required to pay for books that are lost or damaged.**

Minder Binder – Each student will be given a Minder Binder. It must be in the student's notebook. A donation of \$10 will be gladly accepted. Replacement cost is \$10.00. Students are expected to use the Minder Binder daily.

GRADES AND CITIZENSHIP

REPORT CARDS

You will receive one report card every semester. All report cards will be generated online through your Aeries portal account at the end of each semester. You may view, download or print your report card after each grading period.

Progress reports are generated every six weeks and will be available through the Aeries portal.

FAILING GRADES / RETENTION

The LAUSD Board of Education has adopted a student promotion/retention policy, as mandated by the State legislature (AB1626 / AB1639). The intent of legislation is to ensure that students meet essential grade level standards before being promoted to the next grade. Students must progress through the grade levels by demonstrating growth in learning and meeting grade-level standards of expected student achievement.

At the end of the first semester, students who have earned an "F" grade in one or more core academic classes (Reading, Language Arts, Social Science, Math, and Science) will be recommended for

intervention. The plan will require that the student clear the F grade through enrollment in before and/or after school intervention classes, or through completion of remediation work. At the end of the 2nd semester, students must clear F grades through completion of summer school classes. No remediation packets will be assigned.

In addition, students who earn 'F' grades in any class will be monitored by administrative staff, and will not be allowed to participate in end of year activities.

PROMOTION TO NINTH GRADE

Grade 8 students who earn 'F' grades in one or more core academic classes may not participate in end of year activities, including the promotion ceremony. Exclusion to the events will also apply for students with excessive attendance and behavior infractions.

CITIZENSHIP EXPECTATIONS

The following are guidelines created by McAuliffe staff and considered when assigning citizenship marks.

Outstanding – “O”

- Student consistently listens, follows directions, and obeys rules.
- Student is kind, courteous, and respectful towards others.
- Student consistently demonstrates personal responsibility and adheres to the Academic Honesty Code.
- Student participates and adds to the class in a positive and constructive manner.
- Student exhibits a positive attitude.

Satisfactory – “S”

- Student usually listens, follows directions, and obeys rules.
- Student is kind, courteous, and respectful towards others.
- Student usually demonstrates personal responsibility and adheres to the Academic Honesty Code.
- Student participates appropriately in class and seldom needs correction by the teacher.
- Student usually exhibits a positive attitude.

Needs Improvement – “N” (2 demerits earned for each “N” mark)

- Student regularly needs reminders to listen, follow directions, and obey rules.
- Student often requires reminders to be kind, courteous, and respectful towards others.
- Student has difficulty demonstrating personal responsibility and/or violates the Academic Honesty Code.
- Student frequently interrupts class with disruptive behavior and interrupts other students' right to learn.
- Student may display a negative attitude.

Unsatisfactory – “U” (4 demerits earned for each “U” mark)

- Student does not listen, follow directions, or obey rules.
- Student is disrespectful towards the teacher and/or other students, and makes little attempt to change behavior.
- Student fails to take personal responsibility.
- Student consistently disrupts class and interrupts other students' right to learn.

- Student exhibits a negative attitude.

STUDENT ACTIVITIES

ACTIVITIES

During your time at McAuliffe, you will have a chance to participate in a variety of school activities. Listen to the daily announcements and check your weekly emails for upcoming events. Weekly bulletins are posted in every classroom and sent electronically.

BULLETIN

Information concerning school activities and upcoming events is presented in the bulletin, which is read in the student's first period class. Special announcements are also read over the P.A. system. If you have questions concerning bulletin items, ask your first period teacher or look for the bulletin posted in each classroom, or visit the McAuliffe website at www.losal.org.

INTRAMURAL SPORTS

Each quarter, teams will compete in Intramural Sports. Sports will include football, volleyball, volley-tennis, soccer, basketball, softball, track and field, and others.

Athletes are to practice good citizenship and sportsmanlike conduct. Students unable to display proper sportsmanship may be excluded from Intramurals.

During Intramurals, school rules are in effect. **Students with medical excuses in PE may not participate in Intramurals.**

ASSEMBLIES

Please be courteous and responsible at assemblies. Talking, whispering, whistling, stomping of feet and booing are discourteous.

1. Students will enter assemblies in an orderly manner and sit with their classes.
2. When the speaker of the assembly asks for your attention, please give it to him/her immediately.
3. Be courteous to the performers and to your neighbor.
4. Applause should be generous, courteous, and in keeping with the occasion.
5. Students will be dismissed in an orderly fashion by the person in charge.

The purpose of the rules is to maintain an orderly atmosphere that will enable students to enjoy themselves in safe and pleasant surroundings, and to assure appropriate behavior. School policy is to have more social events when student behavior is good and to cut back or cancel events if behavior is inappropriate.

STUDENT GOVERNMENT

The business of the study body is conducted by the Student Body Officers. The ASB is comprised of 6th, 7th, and 8th grade students.

To be eligible for an ASB position, a student must have at least a 2.5 grade point average and maintain satisfactory citizenship.

STUDENT RECOGNITION

The McAuliffe staff is proud to recognize our students. Below is a sample of the ways in which our students can be recognized for their achievements, efforts, and citizenship.

EAGLE EXPRESS CARDS

Staff members may reward students demonstrating excellent behavior or effort with an Eagle Express Card. Eagle Express Cards may be redeemed to get to the front of the lunch line and for price drawings quarterly.

HONOR ROLL

3.0-3.49 GPA with no N's or U's in Citizenship. The Honor Roll students are celebrated in various ways during the year.

PRINCIPAL'S HONOR ROLL

3.5 GPA or higher with no N's or U's in Citizenship. The Principal's Honor Roll students are celebrated in various ways during the year.

STUDENT OF THE MONTH AWARDS

A program that recognizes students who have demonstrated outstanding performance. Teachers select students monthly and those students are issued a certificate.

EIGHTH-GRADE AWARD NIGHT

An end of year event that recognizes exemplary academic performance. In addition, students may earn a **Community Service Award** for completion of 100+ hours of volunteer work each year during grades 6-8. Students are responsible for keeping track of and verifying hours. Forms are available at the ASB desk.

Class of 2022: 300 minimum hours earned

8th Grade students who earn a 4.0 for all 3 years will receive an Academic Excellence Award instead of Principal's Honor Roll at Awards' Night.

BIRTHDAYS

Please DO NOT bring flowers, balloons, or decorated posters for your students and/or friends. These are a distraction in the classroom and should not be brought to school.

Students may be celebrated by having their name appear on the school marquee through our Make-A-Wish club program. Go to the school website for more details and how to sign up.

SCHOOL RULES AND DISCIPLINE

DISCIPLINE PHILOSOPHY AND POLICY

Everyone benefits from good discipline in their school. Students learn more and develop a feeling of pride because they are part of a positive environment. Instruction is more effective because teachers are able to spend time and effort helping students instead of dealing with behavior problems. Social events are more fun because they are not spoiled by unpleasant disruptions and unruly people. Properly administered discipline enables the students to work, play and live in a pleasant, safe atmosphere where they enjoy greater personal freedom without intimidation or fear.

Every student will be made aware of how he/she should behave while attending McAuliffe, and then be held accountable for his/her actions. Discipline will be firm, fair and strictly enforced.

GENERAL SCHOOL RULES

Students are to follow the directions of all school staff. This includes teachers, administrators, custodians, clerks, aides, secretaries and district personnel. Disrespect toward any staff member will not be tolerated.

CLEAN CAMPUS

We ask each student to do his/her part in keeping the corridors and grounds clean. With as many students as we have on campus, it is a full time job for everyone. Those responsible for littering will be expected to clean up other persons' litter as well as their own.

CONDUCT TO AND FROM SCHOOL

As a student of McAuliffe you are expected to behave in a responsible manner on the way to and from school. You are expected to report directly to school after leaving home in the morning. You are to report home after school is dismissed, unless you are participating in approved after school activities. School rules and behavioral guidelines apply to you on your way to school as well as on your way home.

Loitering (hanging out) on campus, on the outskirts of campus, in the street, or in surrounding neighborhoods is not allowed. Students must leave campus immediately following dismissal unless participating in a school approved activity.

DRUG DETECTION CANINE

The Board of Education established a Substance Abuse Task Force in 2007 to ensure the health and safety of all students. The task force made a number of recommendations, one being the use of canine searches on all secondary school campuses. McAuliffe's campus and grounds will be randomly inspected during the school year. The detection canines are very friendly, non-aggressive retriever breeds and will not be used to search students.

VOLUNTARY DRUG TESTING

Drugs and alcohol among adolescents are a major concern for both educators and parents. The use of illegal substances can lead to harmful and even disastrous results for everyone involved.

It is, therefore, important to empower students and parents to avoid the pitfalls associated with drug and alcohol use. To achieve this goal, McAuliffe Middle School has implemented a Voluntary Drug Testing Program. The program is free of charge, confidential and non-punitive. Students who participate may, on a random basis, be selected to undergo a voluntary drug test. The tests will be administered on the McAuliffe campus during the school day in a private and secure location. All tests will be conducted by trained professionals. Information regarding the test results is confidential and will only be released to parents/guardians. No results, positive or negative, will be given to McAuliffe. If a test is positive, the testing company will provide referrals to appropriate counseling and rehabilitative services. The goal of the McAuliffe Middle School Voluntary Drug Testing Program is to enlist the assistance and support of parents to help our adolescents combat and win the fight against drug and alcohol use.

HALL PASSES

No student is to be out of any class without a pass. In cases where it is essential for a student to be out, the proper pass must be obtained from the teacher. If a student leaves any classroom without permission from the teacher and/or a pass, the student will be considered truant.

STUDENT PERSONAL PROPERTY

Students may not bring personal items such as: toy objects, air pods, slime, cameras, large amounts of money, etc. to school. Personal property brought to school for a class assignment must be taken to the appropriate class before school and left there until the end of the school day.

CELLULAR PHONES/SMART WATCHES

Students may possess cell phones and smart watches, at school **BUT** their use, including text messages, **is prohibited once students arrive on campus.** Student's must turn off their devices while on school grounds. It is recommended that they store cell phones in their lockers during school hours. Students may not use their cell phones to take photographs or videos. These devices are brought to school at your own risk and the school is not responsible for anything that is lost or stolen.

If personal property is brought to school, the item will be confiscated by a staff member and given to the Assistant Principal. The item will be held in the office and must be picked up by a parent or guardian and a consequence/detention will be issued.

Consequences for violating the Personal Property Policy including cell/watch phone violations are as follows:

- 1st Offense:** Detention
- 2nd Offense:** Double Detention
- 3rd Offense:** 2-hour Saturday School

LIBRARY / MEDIA CENTER

The Media Center at McAuliffe provides resources and instructional assistance in all areas of the curriculum at all grade levels. Students

who live in an information society need access to a media-rich environment. The library/media program has the potential to implement, enrich, vitalize, and humanize the educational program. McAuliffe has two part-time staff members. Students are encouraged to use the Media Center for research work, recreational reading, and computer projects. Hours are Mon., Tues., and Thurs., 8:15 a.m. to 3:35 p.m.; Wed., 8:15 a.m. to 2:35 p.m.; and Friday, 8:15 a.m. to 3:25 p.m.

Students are responsible for books checked out in their name. At the end of the year if there are any outstanding books or fines and if the student purchased a yearbook, the yearbook may be held until all books are returned and the fines are paid.

CARE OF TEXTBOOKS

Textbooks are issued free of charge to all students, who then will be held responsible for their care. All textbooks must be covered with a book cover. The pupil's name must be written in ink in the proper space provided in each book. **Students will be required to pay for all lost books or books that are damaged and not returned in good condition.** Yearbooks and report cards will be held until books are returned or paid for. If a book that has been paid for is found, the money will be refunded.



BREAKFAST/LUNCH CAFETERIA RULES

Breakfast/Lunch is a time of eating, relaxing and enjoying friendships. In order for lunch to be a positive experience for all, the following guidelines have been established:

1. Orderly conduct is expected. No running, shouting, throwing food, sitting or standing on top of tables.
2. Littering is prohibited. Do not throw trash at other students. Put all lunch refuse in the trash containers as you leave your table.
3. **NO cuts in line.**
4. Stay in designated areas during lunch time.
5. Have good table manners. Sit down during lunch and don't annoy others.
6. No food or drink is to leave the boundaries of the lunch area. This includes the basketball courts and student restrooms.
7. Noon aides have the right to enforce all of the above rules. Consequences will be assigned for improper behavior in the lunch area.

The school office does not loan money for lunches. Therefore, in the event that a student forgets lunch money, he/she may telephone a parent or contact a school cafeteria employee who will provide a lunch.

On minimum day schedule, students may pre-order a lunch for the end of the day. Orders are taken in the morning at the cafeteria.

FOOD

Food is to be consumed in the lunch area only. All food and beverages are to be consumed and containers properly disposed of in the trash can. Students are not to take lunches or food into

classrooms. In addition, shelled seeds and nuts are not allowed on campus.

FOOD ALLERGIES – Please be aware there are students with life-threatening food allergies. We have peanut and fish free tables in the lunch areas. Students bringing any peanut or nut products are encouraged to use hand wipes after eating. Parents may not bring treats to classrooms. We appreciate your cooperation in our endeavor to keep all students safe.

Students with special diets requiring accommodations in the cafeteria due to life threatening medical conditions are required to submit a Medical Statement. For more information, please call (562) 799-4592 x81115.

GUM

Gum chewing is not allowed anywhere on campus before, during, or after school.

CANDY

1. No student should ever be in possession of large quantities of candy.
2. Candy sold for personal profit or for fundraising is not allowed.

DRESS CODE

The McAuliffe Middle School Standards of Dress and Grooming have been created to provide students with the opportunity to choose clothing that helps support a positive learning environment. The goal of the dress standards is to offer students choice of dress, as well as make sure students wear clothing that is appropriate, functional, and does not cause a distraction.

Clothing:

1. Pants or shorts that are excessively large at the waist, hang down far enough to cause a hazard while walking or running, are split, frayed or are excessively baggy should not be worn to school. Pants and other clothing must be worn at a level that avoids the exposing of undergarments or skin. Clothing that is skin-tight, sheer or revealing is not appropriate for students to wear at school.
2. Pants and shorts must stay up without a belt and must fit at the waist without alteration. **All shorts/skirts must have a minimum of a 3-inch inseam.**
3. Blouses and shirts must cover a student's stomach and should not expose the back or midriff section. Students are not allowed to wear low cut blouses, tube tops, sleeveless t-shirts, and tank tops. **Outer garments must conceal undergarments.**
4. Spaghetti strap garments are not allowed.
5. Dresses, skirts, and shorts must be of an appropriate length to avoid exposing undergarments or creating a distraction.
6. Clothing that has the appearance of being lingerie (undergarments) or pajamas are not appropriate school wear. Appropriate undergarments must be worn.

7. Overalls that are oversized, do not fit at the waist or have the tops/straps hanging down are not permitted. Bondage-type pants may not have straps hanging down.
8. No clothing may be worn with inappropriate words or designs.
9. Any type of clothing or accessory that is deemed unsafe, disrupts the learning environment, advertises or advocates alcohol, smoking, drugs, gangs, profanity, weapons, violence, illegal activities, degrades cultures, genders, races, religions, or ethnic values, may not be worn to school at any time.
10. Excessively torn and/or shredded clothing may not be worn.

Shoes:

Backless sandals and platform or high heeled shoes over three inches are unsafe footwear due to the inherent safety problems. Shoes should be secured to the foot and must have a heel strap. No heeels (skate shoes) or bedroom slippers.

Accessories:

1. Belts that are excessively long, as well as large belt buckles, are not appropriate for school. They can pose a safety hazard to students and therefore should not be worn at school.
2. Wallet chains, large bracelets, spiked jewelry, large chains, and other such jewelry can pose a safety hazard to students and are not to be worn at school.
3. Body piercing, tongue studs/rings, eyebrow studs/rings, lip studs/rings, nose studs/rings may not be worn.

Makeup and Hair Styles:

Extreme hair styles or make-up are not appropriate for school. Students who use make-up or consider changing the natural color of their hair need to insure that the change will not in any way disrupt the teaching or learning process.

Violations of dress code can result in the following, students are expected to change into school loaners and:

- | | |
|--------------------------------|------------------------|
| 1st Offense: | Detention |
| 2nd Offense: | Double Detention |
| 3rd Offense: | 2-hour Saturday School |

FAMILIARITY

Students must refrain from familiar contact at school, such as kissing, hugging, etc. Parents will be notified in cases where students violate this rule.

PROFANITY

Profanity is not permitted. Any use of inappropriate language will result in a referral, detention and possible suspension.

GAMBLING

Gambling/card playing on school grounds, including lagging, coin flipping, etc., are not allowed and may be cause for suspension from school.

CHEATING

It is important for every student to develop a sense of honor and integrity, and to get the most possible out of school. Cheating is considered academic dishonesty and will result in an "N" on the report card and/or receive no credit on the assignment or test.

CARE OF SCHOOL PROPERTY

Any student who willfully cuts, defaces or otherwise damages personal property or other property belonging to the school district is liable for suspension or expulsion and the parent or guardian shall be liable for all damages so caused by such pupil. Students are not to bring marking pens to school except as requested by teachers for special projects. Permanent markers should never be brought to school.

HARASSMENT

Harassment is defined as conduct sufficiently severe or pervasive enough to have a negative impact upon the victim's academic performance or to create an intimidating, hostile or offensive educational environment. Some examples of harassment may include but not be limited to:

1. Unwelcome leering, flirtations, or propositions.
2. Unwelcome slurs, threats, derogatory comments, or degrading descriptions.
3. Unwelcome jokes, stories, drawings, pictures, or gestures.
4. Touching an individual's body or clothes in an inappropriate manner.
5. Purposely limiting a student's access to educational tools.
6. Retaliating against an individual who reports a violation.

Any complaint regarding harassment should be reported to the Principal or Assistant Principal immediately.

BULLYING

Students at McAuliffe Middle School are expected to treat each other with respect. If you are being bothered or bullied by someone, report the incident to a school staff member immediately. Remember that words have a life of their own – think before you speak.

DETENTION

After school detention or lunch detention may be assigned. Failure to serve detention may result in a double detention, Saturday School, or suspension.

SATURDAY SCHOOL

Truancies, excessive tardies, excessive detentions, or serious misbehavior may result in assignment to Saturday School. Saturday School is held from 8 a.m. to 12 p.m. on designated Saturdays.

SUSPENSION / EXPULSION

Suspension is the removal of a student from ongoing classroom instruction for a specified number of days. Suspensions may be served on campus or at home at the discretion of the administrator. Expulsion is the removal of a student from the Los Alamitos Unified School District.

SUSPENSION / EXPULSION (continued)

The following excerpts from the Education Code Section 48900 list the grounds for suspension or expulsion of students from school:

1. Caused, attempted to cause, or threatened to cause physical injury to another person.
2. Willfully used force or violence upon another, except in self-defense.
3. Possessed, sold, or otherwise furnished any firearm, knife, explosive, or other dangerous object.
4. Unlawfully possessed, used, sold, or otherwise furnished, or been under the influence of, any controlled substance.
5. Unlawfully offered, arranged, or negotiated to sell any controlled substance (drug), an alcoholic beverage, or intoxicant of any kind, and then either sold, delivered, or furnished another liquid, substance, or material and represented it as a controlled substance (drug), alcoholic beverage, or intoxicant.
6. Committed or attempted to commit robbery or extortion.
7. Caused or attempted to cause damage to school property or private property.
8. Stole or attempted to steal school property or private property.
9. Possessed or used tobacco or any products containing tobacco or nicotine products.
10. Committed an obscene act or engaged in habitual profanity or vulgarity.
11. Had unlawful possession of, or unlawfully offered, arranged, or negotiated to sell any drug paraphernalia.
12. Disrupted school activities or willfully defied school authority.
13. Knowingly received stolen school property or private property.
14. Possessed an imitation firearm.
15. Committed or attempted to commit a sexual assault or committed a sexual battery.
16. Harassed, threatened or intimidated a student who is a complaining witness in a school disciplinary proceeding.
17. Engaged in, or attempted to engage in, hazing. For purposes of this subdivision, "hazing" means a method of initiation or pre-initiation into a pupil organization or body, whether or not the organization or body is officially recognized by an educational institution, which is likely to cause serious bodily injury or personal degradation or disgrace resulting in physical or mental harm to a former, current, or prospective pupil. For purposes of this subdivision, "hazing" does not include athletic events or school-sanctioned events. Ed. Code 48900(q).
18. Engaged in an act of bullying, including, but not limited to, bullying committed by means of an electronic act, as defined in subdivisions (f) and (g) of Section 32261, directed

specifically toward a pupil or school personnel. Ed. Code 48900(r).

19. Committed sexual harassment. Ed. Code 212.5 and 48900.2 (Grades 4-12 only).
20. Caused or attempted to cause, threatened to cause or participated in any act of hate violence. Ed. Code 48900.3 (Grades 4-12 only).
21. Intentionally engaged in harassment, threats of intimidation against school district personnel or students by creating an intimidating or hostile educational environment. Ed. Code 48900.4 (Grades 4-12 only).
22. Made terrorist threats against school official and/or school property. Ed. Code 48900.7.

EXPULSION ON THE 1ST OFFENSE

- Students found to be **possessing, selling, or furnishing any firearm** will be subject to expulsion from the district on the first offense.
- Students found to be **selling any controlled substance** will be subject to expulsion from the district on the first offense.
- Students found to be **brandishing a knife at another person** will be subject to expulsion from the district on the first offense.
- Students found to be **committing or attempting to commit a sexual assault or committing a sexual battery** will be subject to expulsion from the district on the first offense.

BICYCLES / SKATEBOARD/ BIKE HELMETS

Students who ride bicycles/skateboards to school must observe these rules:

1. Students must stay on designated bike paths.
2. Students may not ride their bikes/skateboards on campus.
3. Students must have their own locks.
4. Students must wear their helmets.
5. Students must lock their bike helmets to their bikes or place them in their backpacks or lockers.
6. Students must put their bike/skateboards in designated racks and must lock items.
7. Students may not lock their bikes to other bikes.
8. The bike racks are secured from 9:00 a.m. to 3:10 p.m.

BUS REGULATIONS

- Be considerate of the property near the loading area.
- Line up in an orderly manner on the curb in preparation for boarding the bus.
- Present bus pass to the driver. **Passes are not transferable.**
- Take seats quietly. (Three students to a seat may be necessary.)
- Keep all parts of your body inside the bus.
- No food or drinks allowed on the bus.
- Talk quietly and in an orderly manner.
- Keep hands, feet, and objects to self.
- Do not tamper with bus seats or equipment.
- Leave bus quietly and carefully. Keep away from the side of the bus as it departs.

Students and parents sign an agreement regarding the bus rules of conduct (included in the registration packet). Violation of any of the above rules may result in immediate loss of bus riding privileges as outlined below:

- 1-5 days of riding privilege
- 20-60 days of riding privilege
- Remainder of the year

Students who forget or lose their student ID bus pass will be allowed to ride to school in the morning. It will be the student's responsibility to obtain a temporary bus pass from the attendance clerk before school or during lunch. (See "ID Cards")

DELIVERIES

It is the student's responsibility to remember all books, lunches, and assignments and not to ask parents to bring missing supplies to school. However, in an emergency, parents may leave items in the office for delivery to students. A Personal Property Delivery Form must be completed and attached to items for delivery. Remember, every delivery interrupts classes, stops instruction, and takes office personnel away from their tasks. Additionally, items such as balloons and flowers will remain in the office until the student picks them up at the end of the school day.

LOCKERS

All students will be issued a locker and a combination lock. Grade 7 and Grade 8 students may use their locks from the previous year. **STUDENTS MUST USE A MCAULIFFE-ISSUED LOCK.** Lockers are issued to students as a convenience by the school. **Lockers are subject to inspection at any time.** It is very important for parents to realize that the street lockers are attached to the outside structure of our buildings and are therefore vulnerable, especially outside the school day hours and on weekends. **Because of their location, we are sorry that the school cannot be responsible for damaged or stolen locks or property contained in these lockers. When books are issued, they become the responsibility of students and parents. We encourage students to take books home on weekends and particularly over long holidays.**

LOCKER PROBLEMS

If a student is unable to open their locker during passing period, they must report to class before the tardy bell rings and inform their teacher. A jammed locker is not an excuse for being tardy to class!

LOCKER RULES

Your locker is for "your" use only.

- Stickers, contact paper, paint, wallpaper, deodorizing sticks, etc., are not permitted in lockers.
- Magnetized mirrors and non-permanent organizers are acceptable.
- Do not try to put more than one backpack in a locker.
- Make sure all backpack straps and clothing are safely inside the locker before closing.
- All students are responsible for items left in lockers.

- Do not share your locker or locker combination with any other students.

LOST AND FOUND

Students are to assume responsibility for loss or damage to their personal property. School personnel attempt to provide for the protection of property, but the school is not responsible for the replacement of locks and personal items. Students are encouraged to write their names on all personal belongings. Students are asked to return items they find to the office.

A lost and found rack is located in the breezeway by the main office. Note: Items not claimed from lost and found at the end of each quarter will be donated.

PARENT INVOLVEMENT

Several parent organizations and committees, such as PTA and School Site Council, provide valuable volunteer time, financial support, and advice for the overall improvement of our school. School effectiveness is positively impacted by frequent parent participation. Meetings are publicized regularly in the newsletters, school web pages, and the auto dialer system.

Parents are welcome at school. Visits must be planned in advance with the office. This will assist in providing minimal interruption to the instructional program. To ensure the safety of our students, all visitors are required to check in through the office before proceeding to a classroom.

Teachers communicate with parents about student progress in a variety of ways. These include individual parent conferences, telephone calls, notes, websites, Aeries, Remind App, etc. and progress reports. In addition, parents are encouraged to inform school personnel about significant changes in the home environment that may affect the student's school performance.

STATE ASSESSMENTS

McAuliffe Middle School students participate in California State Assessments in the spring of their 3rd, 4th, 5th, 6th, 7th, 8th, and 11th grade year. These assessments demonstrate student achievement and are tools that teachers use to customize and modify instruction to best meet the needs of all students. Parents may opt out of a state assessment by submitting a request in writing to the school. In California, assessment results are linked to high school graduation, college access, and career readiness.

DERMERIT SYSTEM

This program assigns students demerits for unsatisfactory behavior as evidenced by:

<u>Consequence</u>	<u>Demerit</u>
1. Referral to Office	1
2. Detention	1
3. Citizenship "N"	2
4. Citizenship "U"	4
5. Saturday School	1 per hr.

6. Suspension

3-5

Students with **10 or more demerits per semester** are not able to participate in lunchtime privileges, assemblies, intramurals, clubs, field trips, special activities, etc., for the semester in which the demerits were earned. Students who receive any 1st semester F's will not be allowed to participate in the end of the year track meet and activities.

Students are unable to work off demerits. At the start of each new semester, all demerits will be erased. Second semester demerits will affect participation in end of the year activities and assemblies.

Eighth grade students with 10 or more demerits at the end of the year are excluded from participation in all eighth-grade activities, excluding promotion, providing the student has successfully passed his/her classes.

An inter-district student with 10 or more demerits during any semester is placed on probation until the end of the next semester. To be removed from probation, the student must:

1. Finish probationary semester with no citizenship 'N's' or 'U's'.
2. Refrain from earning 5 or more demerits during the probationary semester.
3. Earn passing grades in all classes.

If at the end of the probation period, the student has not satisfactorily met all probationary conditions, the inter-district transfer may be revoked.

ACADEMIC HONESTY CODE

McAuliffe Middle School requires all students to demonstrate honesty and to abide by ethical standards in preparing and presenting materials, as well as in testing situations. Grades should reflect the student's own work in the fairest possible way. It involves any attempt of a student to substitute the product of another, in whole or in part, as his or her own work. It also includes theft, possession, or unauthorized use of any answer keys or model answers.

Violation of the McAuliffe Middle School Academic Honesty Code will be subject to disciplinary action up to and including:

- 'N' on your report card
- Detention
- Saturday School
- Suspension
- Dismissal from student offices and all intramurals and extracurricular activities
- Involuntary transfer and expulsion

This policy covers all school related tests, quizzes, reports, class assignments, and projects, both in and out of class.

CHEATING includes but is not necessarily limited to:

Copy/Sharing Assignments –

Copying or giving an assignment to a student to be duplicated, unless specifically permitted or required by the teacher.

Cheating on Exams or Major Projects –

- Use of unauthorized materials including textbooks, notes, calculators, or computer programs during an examination or on a major project
- Supplying or communicating in any way unauthorized material including textbooks, notes, calculators, or computer programs during an examination or on a major project

Forgery/Stealing –

- Unauthorized access to an exam or answers to exam
- Alteration of computer and/or grade book records or forgery of signatures
- Sabotaging or destroying the work of others

Plagiarism –

- “Plagiarism” is the “act of appropriating the literary composition of another, or parts or passages of his writings, or the ideas or language of the same, and passing them off as the product of one’s own mind”. It involves “the use of any outside source without proper acknowledgment”. In the academic setting, an “outside source” includes “any work, published or unpublished, by any person other than the student”.

YOU ARE CHEATING IF YOU:

- Copy, fax, duplicate, or transmit using technology, assignments that will each be turned in as “original work”
- Exchange assignments by printout, disk/drive, modem, or other electronic or recorded means, then submit it as “original” work
- Write formulas, codes, and/or key words on your personal objects or yourself for use in a test
- Use hidden reference sheets during a test
- Use programmed material in watches, calculators, or computer programs when prohibited
- Exchange answers with others (either give or receive answers)
- Submit someone else’s assignment as your own, in whole or part
- Submit material (written or designed by someone else) without giving the author/artist name and/or source (e.g., plagiarizing, or submitting work done by family, friends, or tutors)
- Take credit for group work, when little contribution was made
- Do not follow additional specific guidelines on cheating as established by a department, class, or teacher
- Steal tests, answers, or materials, or have unauthorized possession of such materials
- Sabotage or destroy the work of others

PARKING TIPS AT MCAULIFFE MIDDLE SCHOOL

Parking at every school is a challenge. At McAuliffe, we are constantly seeking to ensure safe egress and regress for every student. After a study in the Spring of 2019, the following are our rules for parking and traffic at McAuliffe Middle School. There are no exceptions to these rules, as we seek to ensure the safety of every child.

Bloomfield Parking Lot

1. This lot is for loading and unloading of students from 8:00-9:00 and from 2:00-3:00. We ask that parents do not park in the stalls, unless they are coming onto campus for school business.
2. Vehicles must pull all the way forward toward the amphitheatre before unloading students, please do not stop at the gate near the bike rack.
3. Please do not park in the aisle ways between parking stalls, this is for the immediate loading and unloading of passengers only.

Cerritos Lot

1. This parking lot is reserved for our school buses between 8:15 and 9:00 and again from 2:45-3:10, we cannot allow the loading and unloading of students during this timeframe.
2. Visitor parking spots are available for parent parking.
3. Parents may pull into the loading zone between 9:00 and 2:45 for the immediate loading and unloading of students and for brief office visits.

Cerritos Avenue

1. The white zone on Cerritos Avenue is for passenger loading and unloading.



2021-22 School Year

BELL SCHEDULES

Regular Bell Schedule

'0' Period	7:45 – 8:40
Period 1	8:45 – 9:34
Period 2	9:39 – 10:25
Period 3	10:30 – 11:16
Period 4	11:21 – 12:07
LUNCH 1 (6th grade)	12:07 – 12:37
Period 5 (6 th grade)	12:42 – 1:28
Period 5 (7 th /8 th grade)	12:12 – 12:58
LUNCH 2 (7th/8th grades)	12:58 – 1:28
Period 6	1:33 – 2:19
Period 7	2:24 – 3:10
Detention/Study Hall	3:15 – 3:55

Early Release WEDNESDAY Bell Schedule

'0' Period	7:45 – 8:40
Period 1	8:45 – 9:23
Period 2	9:28 – 10:05
Period 3	10:10 – 10:47
Period 4	10:52 – 11:29
LUNCH 1 (6th grade)	11:29 – 11:59
Period 5 (6 th grade)	12:04 – 12:41
Period 5 (7 th /8 th grades)	11:34 – 12:11
LUNCH 2 (7th/8th grades)	12:11 – 12:41
Period 6	12:46 – 1:23
Period 7	1:28 – 2:05
<u>NO DETENTION</u>	

MINIMUM DAY Bell Schedule

'0' Period	7:45 – 8:40
Period 1	8:45 – 9:10
Period 2	9:15 – 9:40
Period 3	9:45 – 10:10
Period 4	10:15 – 10:40
Period 5	10:45 – 11:10
Period 6	11:15 – 11:40
Period 7	11:45 – 12:10
<u>NO DETENTION / NO STUDY HALL</u>	

IMPORTANT DATES 2021-2022

AUGUST

16 Semester Begins
26 Student Fall Pictures

SEPTEMBER

6 No School-Holiday
9 Club Rush Day
9 6th grade Parent Ed Night
14 PTA Meeting
16 Fall Make Up Picture Day
24 6 Week Progress Reports

OCTOBER

8 Non-Student Day-No School
12 PTA Meeting
15/16 Choir Concert-Sound Check
20/21 Drama Black Box Performance
21 Great American Shake Out Drill
25 Red Ribbon Week
26 Fall Conference-Minimum Day
27 7/8 Dance
28/29 Fall Conference-Minimum Day

NOVEMBER

3-5 Choir Musical
5 12 Week
9 PTA Meeting
11-12 Holiday-Non-Student Day
15 12 Week Progress Report
22-26 Thanksgiving Break Begins (1 Week)

DECEMBER

8 Band Winter Performance
14 PTA Meeting
22 18 Week progress report
23 Winter Break Begins (2 Weeks)

JANUARY

10 Non-Student Day/Teacher Planning
11 Student Return-3rd Quarter Begins
11 PTA Meeting
17 No School-Martin Luther King Day

FEBRUARY

1 PE Testing Opens
8 PTA Meeting
9 6th Grade Dance
10 8th Grade Panoramic Pictures
12 JR Thespian Ceremony
16-17 Choir Concert
18 6 Week Progress Report
21-25 President Holiday Begins (1 Week)

MARCH

2 Film Festival
7 All District Choir Performance
8 PTA Meeting
9 McAuliffe Band Spring Concert
14 All District Choral Festival
24 Spring Pictures
29 Spring Conference-Minimum Day
30 7/8th Dance
31 Spring Conference-Minimum Day

APRIL

1 Spring Conference-Minimum Day
4 Abilities Week
9 District Jazz Festival
12 PTA Meeting
13-14 Drama Spring Performance
15 12 Week Progress Report
28 Open House

MAY

2 Teacher Appreciation Week
25 Spring Concert Choir
30 No School-Memorial Day Observance

JUNE

1 MCA vs Oak Track Meet
2 8th Grade Awards Night
4 Band Performance
7 8th Grade Promotion*
8 8th Grade Promotion Party*
9 8th Grade Knott's Field Trip/Field Day*
10 Last Day of School-Yearbook Distribution
10 2nd Semester Ends

**Dates Subject to Change*

MCAULIFFE STAFF

Office Staff

Principal	Dr. Weiss-Wright
Asst. Principal	Mrs. Vienna
Counselor	Mrs. Olmstead
Psychologist	Mrs. Bergeron
School Office Coordinator	Mrs. McCulloch
Registrar	Ms. Wood
Attendance Clerk	Mrs. Johnson
ASB Clerk	Mrs. Treasure
District Nurse	Mrs. Lawrence
School Nurse	TBD
Speech Pathologist	Mrs. Johnson
Speech Pathologist	

Custodial Staff

Mr. Hammond
Mrs. Bettencourt
Mr. Mims

Cafeteria Staff

Mrs. Kaltenthaler
Mrs. Breedlove
Mr. Crepeau
Mrs. Gupta
Ms. Velasquez

Media Center Staff

Media Center Aide	Mrs. Foremski
Media Center Aide	Mrs. Becerra

TEACHING STAFF

Mrs. Acuna	aacuna@losal.org	Ms. Manly	nmanly@losal.org
Mrs. Amundson	bamundson@losal.org	Mrs. Martin, C.	cmartin@losal.org
Mrs. Armstrong	aarmstrong@losal.org	Ms. McGovney	dmcgovney@losal.org
Mr. D. Arnold	darnold@losal.org	Ms. Miller	vmiller@losal.org
Mrs. M. Arnold	marnonld@losal.org	Mr. Pagett	kpagett@losal.org
Mrs. Avalos	lavalos@losal.org	Mrs. Pagett	jpagett@losal.org
Mrs. H. Barnett	hbarnett@losal.org	Ms. Petrick	dpetrick@losal.org
Mr. Bay	pbay@losal.org	Ms. Phillips	dphillips@losal.org
Ms. Bellendir	jbellendir@losal.org	Mrs. Ravelo	kravelo@losal.org
Ms. Callaway	ccallaway@losal.org	Ms. Redden	kredden@losal.org
Mrs. Cathey	icathey@losal.org	Mr. Robinson	srobinson@losal.org
Ms. Copeland	tcopeland@losal.org	Mr. Rose	mrose@losal.org
Mr. Danforth	jdandforth@losal.org	Swihart	kswihart@losal.org
Mrs. Desbrow	ddebrow@losal.org	Mr. Thomson	jthomson@losal.org
Ms. Hwang	jhwang@losal.org	Mr. Tsuji	ktsuji@losal.org
Ms. Edwards	eedwards@losal.org	Mrs. Vanden Berg	jvandenberq@losal.org
Mrs. Fluck	mfluck@losal.org	Mrs. Wallace	swallace@losal.org
Mrs. Stewart	sstewart@losal.org		
Mr. Fontaine	ffontaine@losal.org		
Mr. Happoldt	chappoldt@losal.org		
Mrs. Hearn	whearn@losal.org		
Mrs. LeTourneau	jiletourneau@losal.org		
Mr. Lynes	plynes@losal.org		
Mr. Maffett	amaffett@losal.org		

Revised 6/22/21