

Name:
Period:

Review for Final 2021
Geometry CP

Note to student: *This packet should be used as practice for the Geometry CP Final Exam. This should not be the only tool that you use to prepare yourself for the exam. You must go through your notes, re-do homework problems, class work problems, formative assessment problems, and questions from your tests and quizzes throughout the year thus far.*

Section 1

1) Classify each statement as true or false, and explain your reasoning in each false case.

a) Two planes intersect in only one point. _____

b) A ray starts at one point on a line and goes on forever. _____

c) The intersection of 2 planes is one line _____

d) Any four points are collinear. _____

2) Use the figure below for #6-14. Note that \overleftrightarrow{RN} pierces the plane at N . It is not coplanar with V .

a) Name two segments shown in the figure.

b) What is the intersection of \overleftrightarrow{CM} and \overleftrightarrow{RN} ?

c) Name three collinear points.

d) What are two other ways to name plane V ?

e) Are points R , N , M , and X coplanar?

f) Name two rays shown in the figure.

g) Name the pair of opposite rays with endpoint N .

h) \overleftrightarrow{AN} is the same as \overleftrightarrow{NA} . True or False?

i) ANX names a plane. True or False?

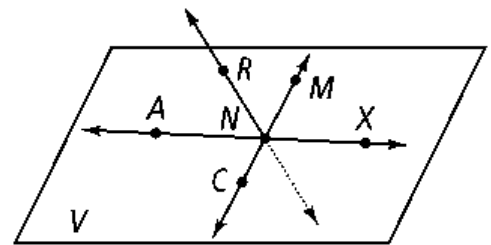

3) Below each figure write the name of the kind of rigid transformation shown.

a.

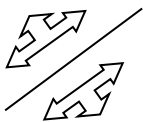

b.

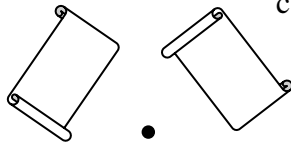

c.

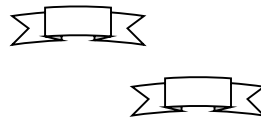

Section 2

Complete the following statements:

1) $\angle ABC$ and $\angle BCD$ are complementary. $m\angle ABC = 6x^\circ$ and $m\angle BCD = 12x^\circ$. Find x .

2) $\angle ABC$ and $\angle BCD$ are supplementary. $m\angle ABC = 40x^\circ$ and $m\angle BCD = 20^\circ$. Find x .

3) $AB = 2x + 1$, $BC = 16$ inches, $AC = 5x - 4$. Use the diagram to solve for x :

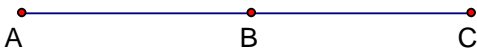

4) Solve for y : $m\angle DGF = 12y - 5$, $m\angle EGF = 24^\circ$, $m\angle DGE = 5y + 6$

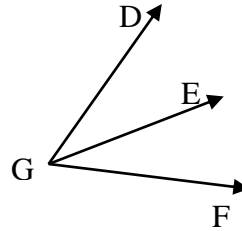

5) \overrightarrow{WS} bisects $\angle BWV$. $m\angle BWS = 32^\circ$. What is $m\angle BWV$?

6) Determine the value of x :

a)

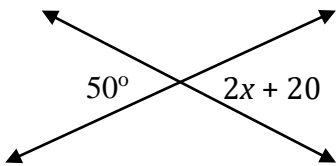

b)

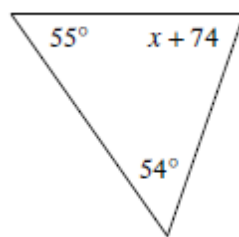

c)

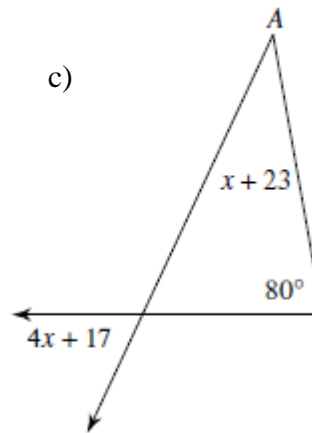

d)

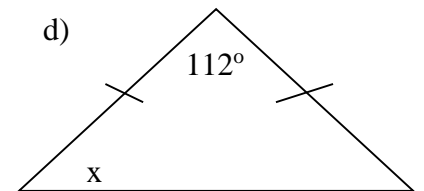

7) Use the following steps to determine whether the given statement is a definition.

Linear pairs are supplementary, adjacent angles.

a) Conditional statement

b) Converse

c) Biconditional statement

d) Decide whether the statement is a definition. Explain your reasoning.

8) Write the conditional statement that corresponds to the Venn diagram below:

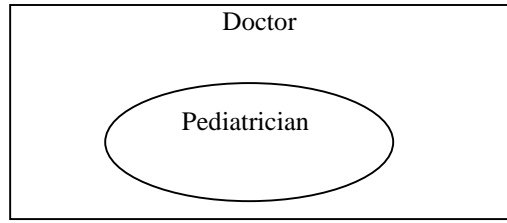

Section 3

1) For the following exercises, refer to the diagram below. Lines m and n are parallel. Name all angles congruent to the given angle and give the theorems or postulates that justify your answer.

- a) $\angle 6$ _____
- b) $\angle 8$ _____
- c) $\angle 5$ _____
- d) $\angle 7$ _____

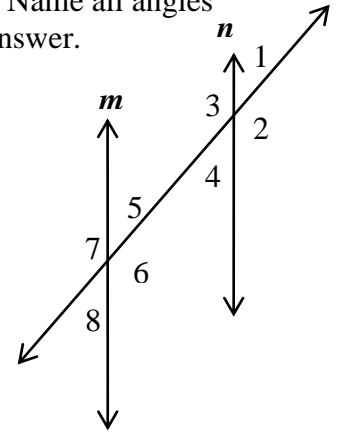

2) For the figure to the right $m\angle BCD = 160 - 3x^\circ$, and

$m\angle CFH = 35^\circ$. What is x ?

What Theorem or Postulate supports your answer?

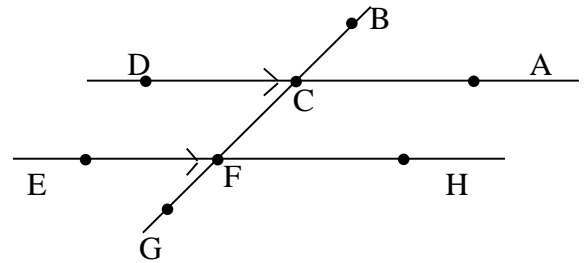

3) For the figure to the right $m\angle BCA = 68^\circ$, and $m\angle CFH = 92 - 8x^\circ$. What value of x makes $\overleftrightarrow{AD} \parallel \overleftrightarrow{EH}$?

What Theorem or Postulate supports your answer?

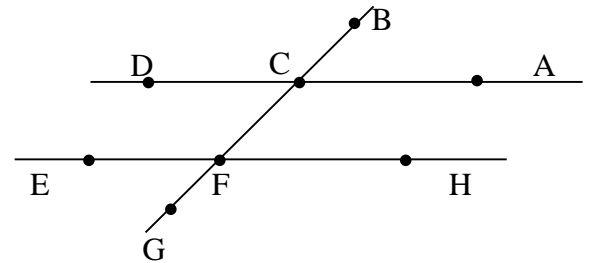

4) Fill in the blanks so that the sentences are true.

- a) The sum of angles in any quadrilateral is _____.
- b) In a parallelogram diagonals _____ and opposite angles are _____.
- c) _____.
- d) A _____ and a _____ have perpendicular diagonals.
- e) A _____ is a quadrilateral with only one pair of parallel sides.
- f) A square is a quadrilateral with _____ congruent sides and _____ right angles.
- g) A rhombus is a _____ with four _____ sides.
- h) A _____ is a quadrilateral with 2 pairs of parallel sides.
- i) Any four-sided polygon is a _____.
- j) A rectangle is a quadrilateral with _____.

5) Polygon DEFG is a parallelogram. $GF = 3$ in, $DG = 2$ in, $m\angle GDE = 110^\circ$

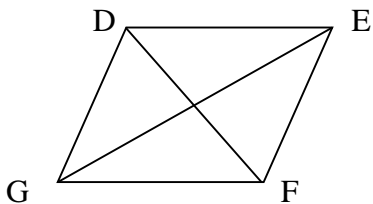

a) $m\angle DGF =$ _____

c) $\overline{EF} =$ _____

b) $m\angle GFE =$ _____

d) $\overline{DE} =$ _____

6) $MNOP$ is a rhombus. If $m\angle MNO = 88^\circ$, find each of the following:

a) $m\angle NOP =$ _____

b) $m\angle OPG =$ _____

c) $m\angle OGN =$ _____

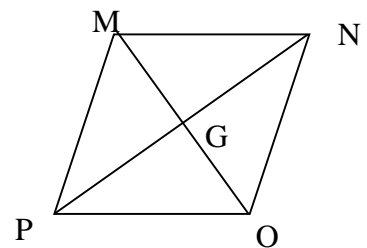

7) Parallelogram $RUST$

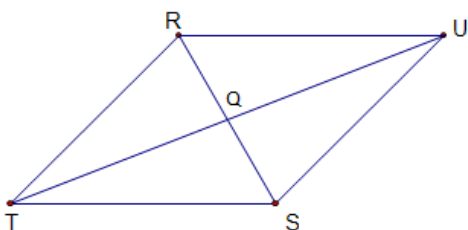

$m\angle RUS =$ 58° $RU =$ 30cm $RQ =$ 9cm

$m\angle UST =$ _____ $US =$ 28cm $QS =$ _____

$m\angle STR =$ _____ $ST =$ _____ $TQ =$ _____

$m\angle TRU =$ _____ $TR =$ _____ $QU =$ _____

$RS =$ _____ $UT =$ 50cm

8) Polygon $ABCD$ is a rhombus. $AB = 4x + 2$ and $AD = 30$. What is x ? Give a reason for your equation.

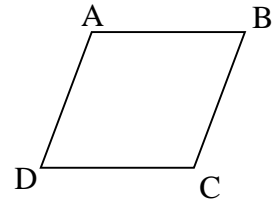

9) Polygon $ABCD$ is a rectangle. \overline{AC} and \overline{BD} intersect to E . $AE = 12 \text{ ft}$. What is BD ?

10) Use trapezoid $TRAP$ to the right to answer the following:

If $m\angle T = 60^\circ$ find the measures of the other angles.

$m\angle R =$ _____ $m\angle A =$ _____ $m\angle P =$ _____

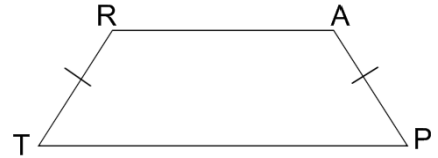

11) Find the following.

a) $NM =$ _____

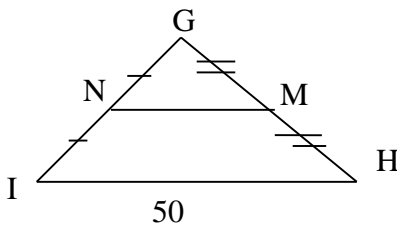

b) $x =$ _____

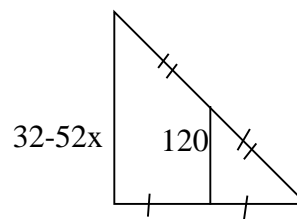

c) What is \overline{NM} called? _____

12) Find the **slope, midpoint, and length** of each of the following segments whose endpoints are given.

a) $(-1, 4)$ and $(4, 10)$

b) $(8, 0)$ and $(10, 6)$

13) Lines that are parallel have _____ slopes and lines that are perpendicular have _____ slopes.

14) Triangle TRI has vertices $T(15,6)$, $R(5,1)$, and $I(5,11)$. Use coordinate geometry to determine if triangle TRI is scalene, isosceles, or equilateral.

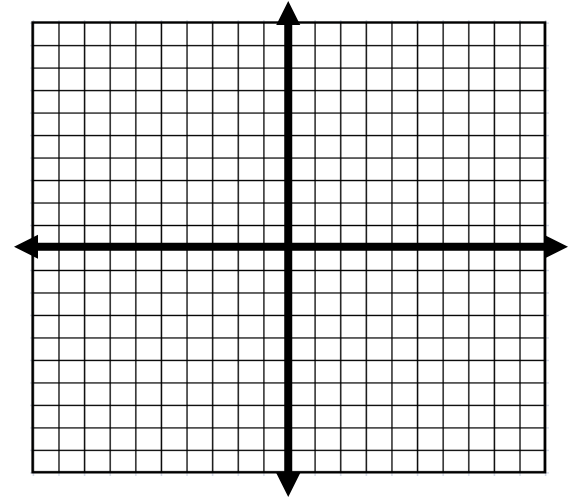

Section 4

1) Write a congruency statement for the following polygons. Why are they congruent?

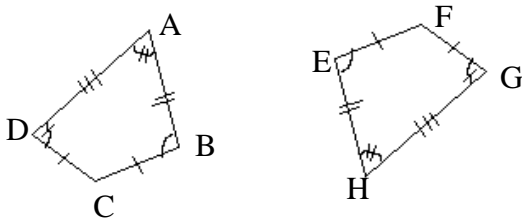

2) Determine whether each pair of triangles can be proven **congruent** by using the SSS, SAS, ASA or AAS congruence postulates. If so, identify what postulate is used.

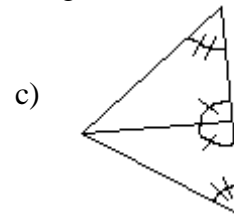
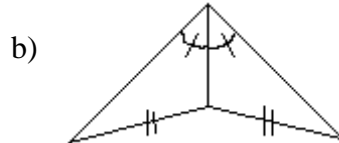
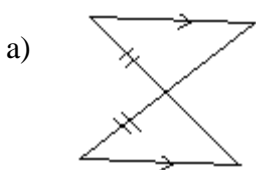

3) Determine whether each pair of triangles can be proven congruent by using the SSS, SAS, ASA, AAS or HL congruence postulates. If so, identify what postulate is used and write a congruency statement.

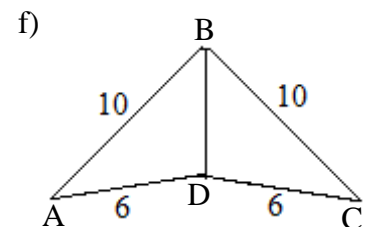
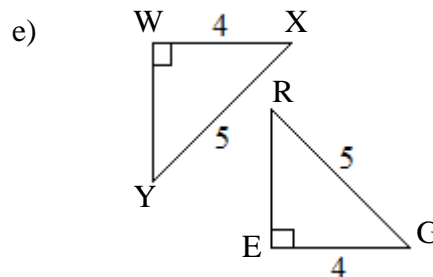
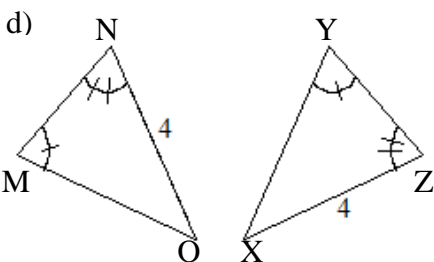
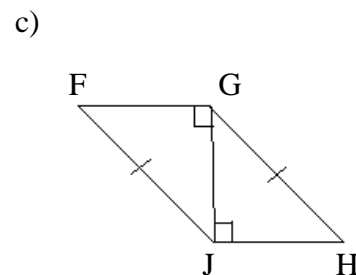
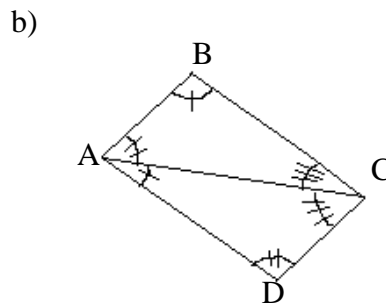
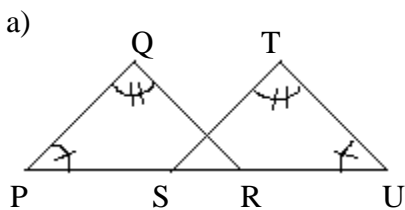

4) Label and state what additional information is required in order to know that the triangles are **congruent** for the reason given.

a) ASA

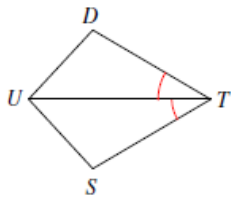

b) ASA

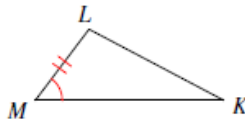

c) SAS

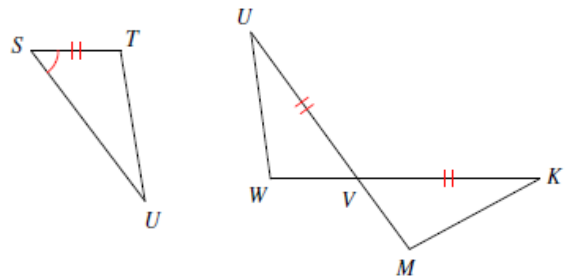

5) Determine whether or not the triangles below are **similar** (you may need to do a little work to figure it out) by AA, SSS, or SAS, or none of them. If they are similar, complete the similarity statement.

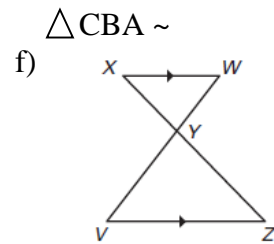
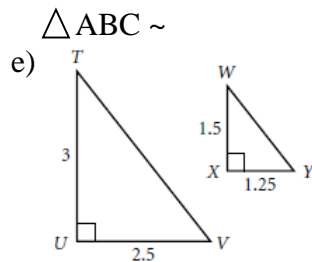
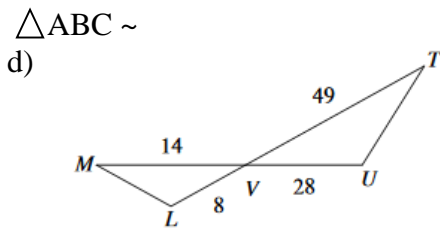
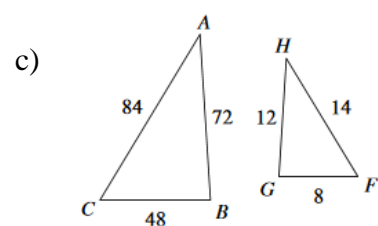
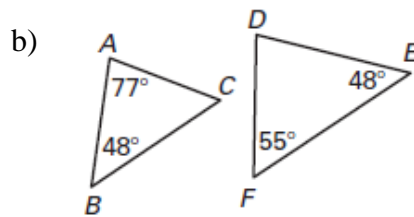
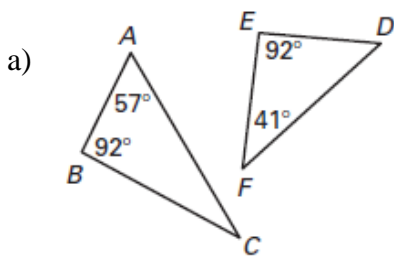

$\triangle LVM \sim$

$\triangle TUV \sim$

$\triangle WXY \sim$

6) Determine whether the polygons are **similar**, **not similar**, or **not enough information** given. If they are similar, determine the scale factor comparing the first to second figure.

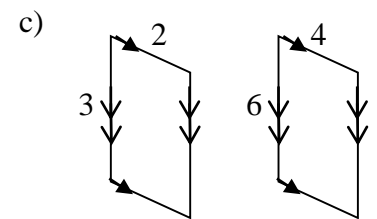
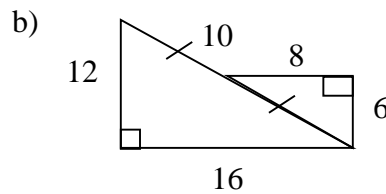
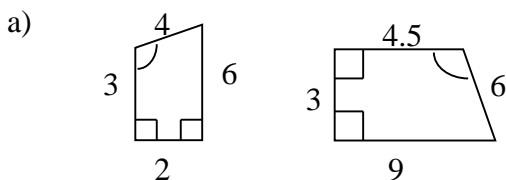

7) The following polygons are similar; find x and y.

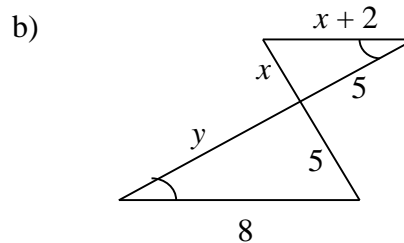
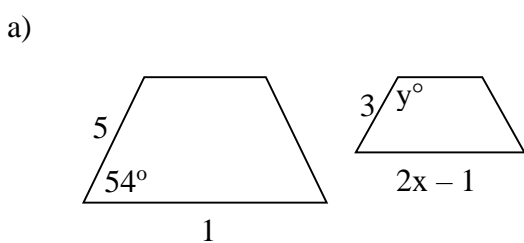

8) $\triangle AFN \sim \triangle DPG$, $AF = 2$ cm., $FN = 3$ cm., $DG = 10$ cm., and $PD = 8$ cm. Find AN . If $m\angle A = 36^\circ$, what is $m\angle D$?

9) Use the following image to explain why the two triangles are similar, then estimate the length of the lake.

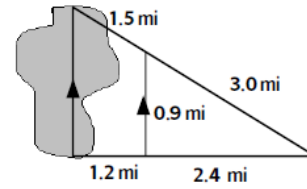

10) Solve for x .

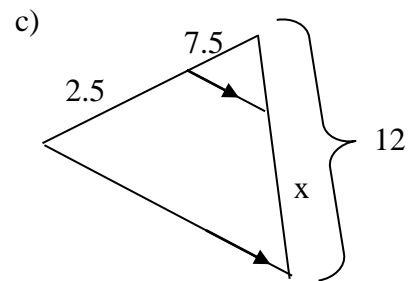
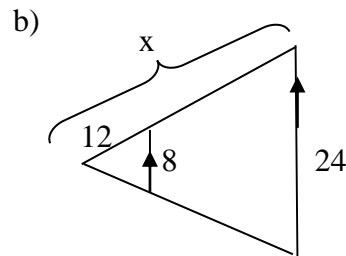
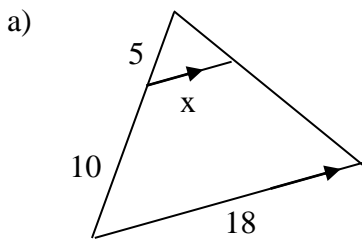

11) Use the diagram to find the height of each building.

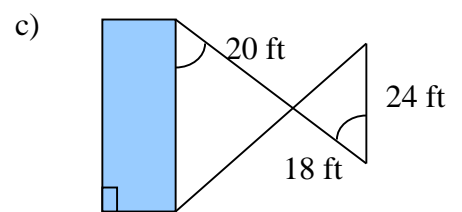
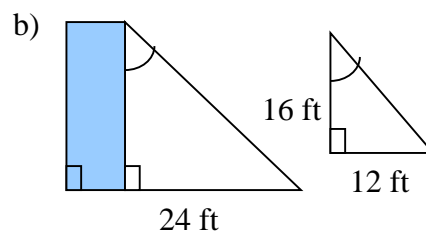
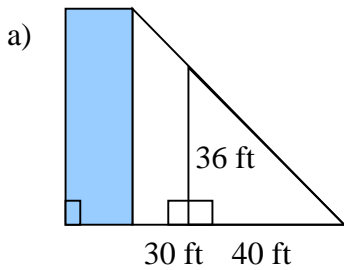

Section 5

1) For # 1-3 two lengths of the right triangle are given. Find the missing length.

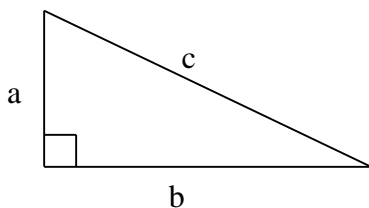

a) $a = 13$ $b = \underline{\hspace{2cm}}$ $c = 14$

b) $a = 12$ $b = 16$ $c = \underline{\hspace{2cm}}$

c) $a = \underline{\hspace{2cm}}$ $b = 7$ $c = 13$

2) A triangle has side lengths given below. Determine what type of triangle each set is (acute, obtuse, or right). Show work to support your answer.

a. 24, 40, and 32

b. 30, 24, and 19

c. 6, 14, and 11

3) Find the missing side lengths. Leave your answers in radical form.

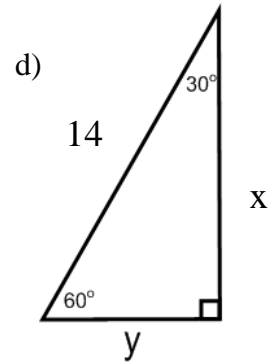
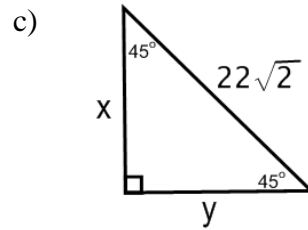
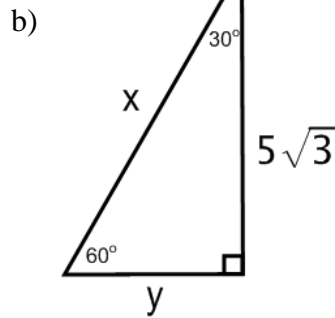
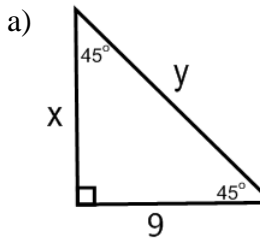

4) For the following, ΔPQR , $m\angle PQR = 90^\circ$, $PQ = 6$, $m\angle QPS = 60^\circ$, and $PR = 12$. Give exact answers.

(HINT: Use special right triangles to solve in radical form!)

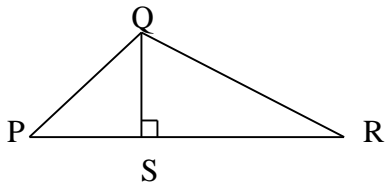

a) Find $QR =$ _____

b) Find $QS =$ _____

c) Find $SR =$ _____

d) Find the area of $\Delta PQR =$ _____

5) Find the area of each figure. Round your answers to the nearest tenth.

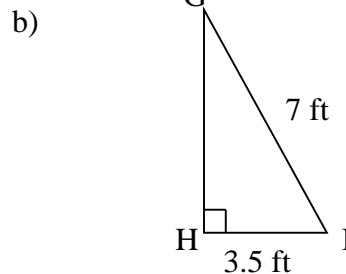
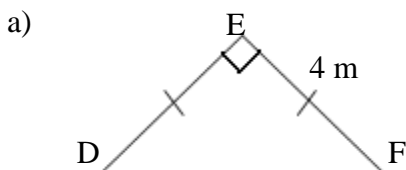

6) Find the area of the following figures.

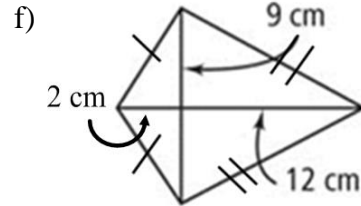
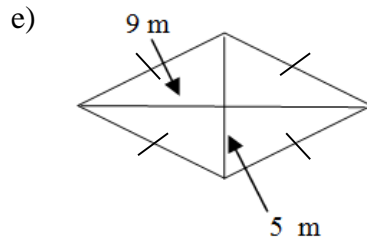
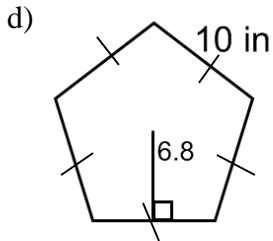
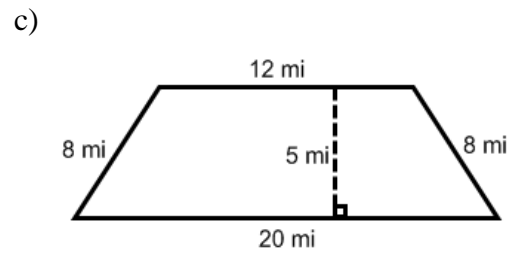
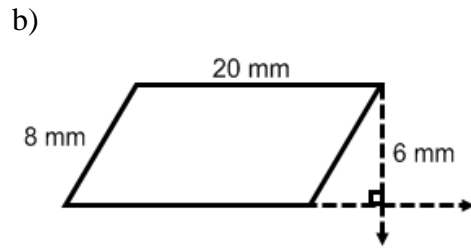
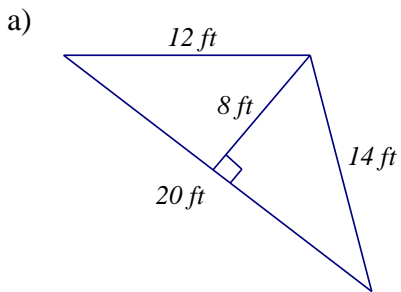

7) Find the circumference AND area of each figure. Leave your answer in terms of π .

a) $r = 8 \text{ mm}$

b) $d = 26 \text{ cm}$

c)

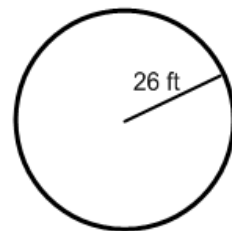

8) Round your answers to 7a) to the nearest hundredth.

C = _____

A = _____

9) Find the radius of each circle from the given information. Round to the nearest tenth if necessary.

a) Area = $256\pi \text{ in}^2$

b) Circumference = 120 ft

r = _____

r = _____

10) If the area of a parallelogram is 100 cm^2 and the length of the base is 25 cm, what is the height?

11) If the area of a parallelogram is 45 ft^2 and the height is 3 ft, what is the length of the base?

12) If the area of a trapezoid is 250 in^2 , the lengths of the bases are 23 in and 27 in, what is the height?

13) If the area of a triangle is $343 u^2$ and the height is $14 u$, what is the length of the base?

14) Find the area of the shaded region.

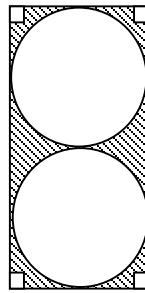

20

15) Find the area of the composite figures below.

a)

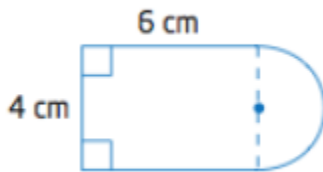

b)

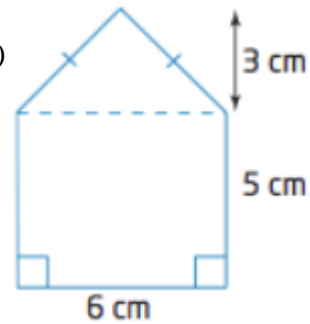

Section 6

1) For the following, refer to the solid below.

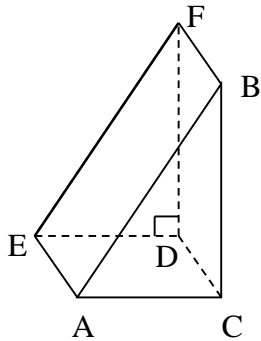

- a) Name the solid. _____
- b) Name a pair of parallel planes. _____
- c) Name two segments skew to \overline{BF} _____
- d) Name two segments \perp to plane BFD. _____
- e) What is the volume of the solid if $BC = 4$, $AC = 3$, and $DC = 2$.

2) What is the slant height of a right cone with a radius of 8 in. and a height of 14 in. _____

Find the Surface Area and Volume of each right prism. Round to the hundredth if necessary.

3) Find the Surface Area, ~~Lateral Area~~, and Volume for the following solids. Give an exact answer.

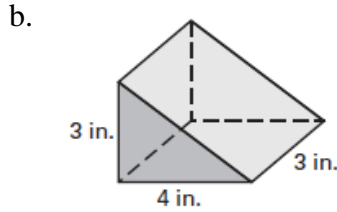
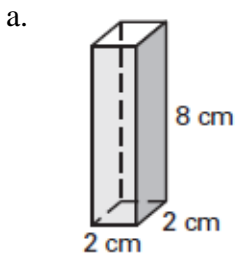

c. $BC = 12$, $CH = 5$, *apothem* = 6.2

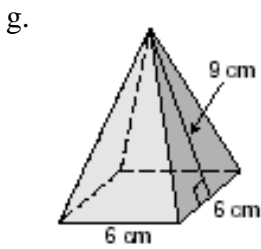
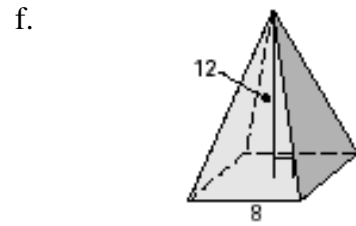
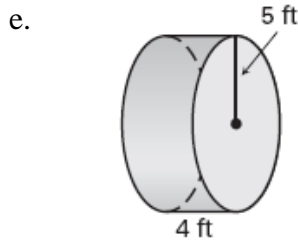
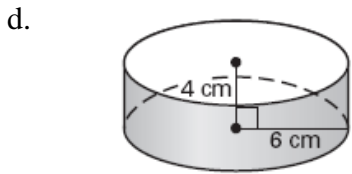
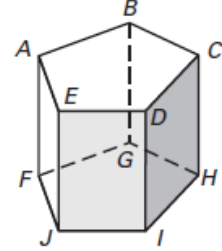

h. *apothem* = 5.2 cm

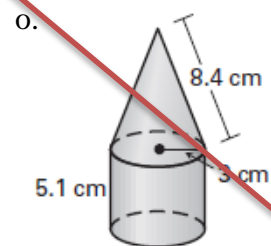
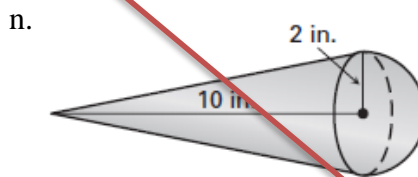
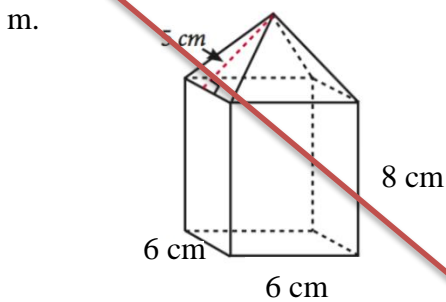
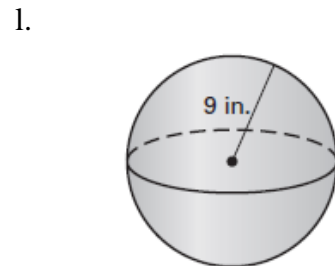
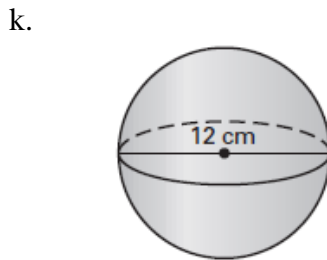
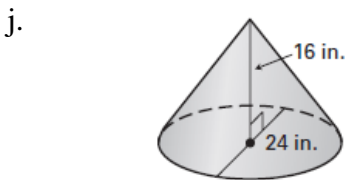
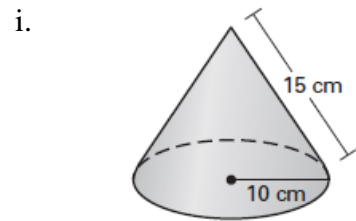
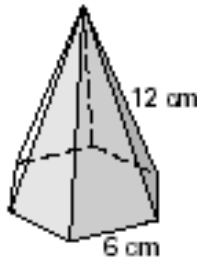

- 4) The surface area of a square pyramid is given by 540 cm^2 and the side of the square is 10 cm. Find the slant height of the square pyramid.
- 5) The volume of a cylinder is 960π cubic inches. The height of the cylinder is 15 inches. Find the radius.
- 6) If a cylinder has surface area of 128π sq ft, and the height of the cylinder is 12 feet, find the radius and the volume.
- 7) The volume of a spherical ball is $5,000\pi \text{ cm}^3$. What is the radius of the ball?

Section 7

- 1) Find the degree measures of each arc or angle by using the central angle measures given in $\odot M$

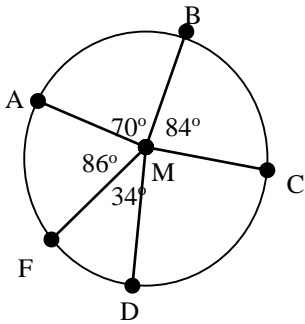

- a) $m\widehat{AC}$ _____
- b) $m\widehat{FA}$ _____
- c) $m\widehat{CBF}$ _____
- d) $m\widehat{DB}$ _____
- e) $m\widehat{ADC}$ _____
- f) $m\widehat{DCA}$ _____
- g) $m\angle DMC$ _____

- 2) Determine arc with length L of a circle with radius 8.5 in and degree measure 240° .

- 3) Each polygon circumscribes a circle. What is the perimeter of each polygon?

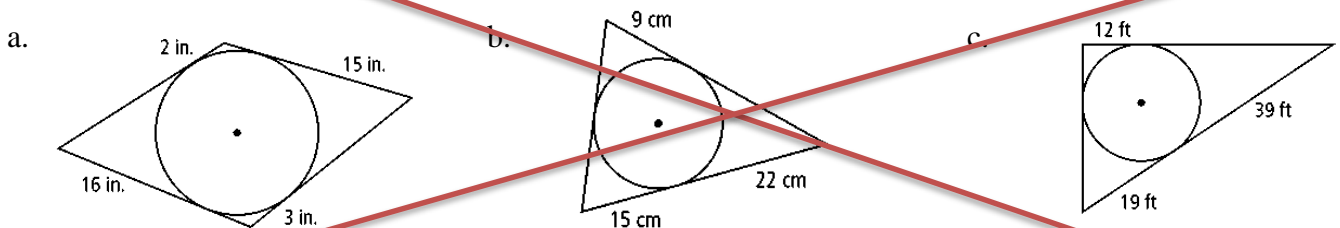

4) Using circle O below, name the following:

- a. Diameter
- b. Central Angle
- c. Minor Arc
- d. Major Arc
- e. Semicircle
- f. Radius
- g. Tangent
- h. Point of Tangency

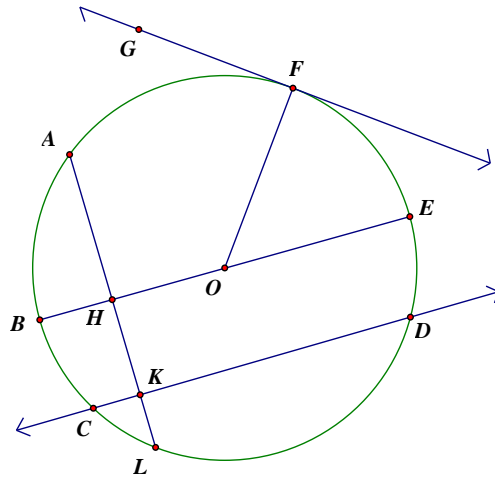

5) For the following, in $\odot M$, \overline{AC} is the diameter, \overrightarrow{DC} is tangent to the circle at point C , and $m\widehat{BC} = 78^\circ$.

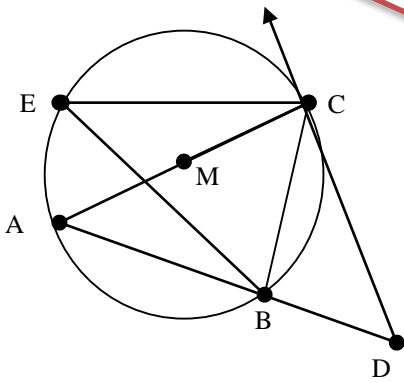

- a) $m\angle BAC$ _____
- b) $m\angle BEC$ _____
- c) $m\widehat{AB}$ _____
- d) $m\angle ACB$ _____
- e) $m\angle ABC$ _____
- f) $m\angle ACD$ _____
- g) _____ is a minor arc, _____ is a major arc
- h) _____ is a radius, \overline{AC} is a _____.
- i) \overrightarrow{CD} is a _____

Find the measure of the arc or angle in $\odot M$.

- 7. $m\angle QMP$
- 8. $m\angle NMO$
- 9. $m\angle PNO$
- 10. $m\angle QNP$
- 11. $m\widehat{QO}$
- 12. $m\widehat{NOP}$
- 13. $m\widehat{PQ}$
- 14. $m\widehat{OQN}$

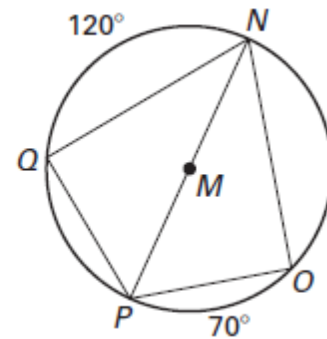

15) What is the value of x ? Lines that appear to be tangent are tangent. Round to the nearest hundredth if necessary.

- a)
- b)
- c)
- d)

16) Write the equation for the circle with center (2, 4) and radius = 7 in

17) Write the equation for the circle with center (-3, 1) and diameter = 18 in

18) Find the center and radius of the circle: $(x-7)^2 + (y+12)^2 = 144$

19) Find the center and radius of the circle: $(x+5)^2 + (y+8)^2 = 225$

20) Graph the circle on the coordinate plane.

a. $(x+2)^2 + (y-4)^2 = 16$

b. $(x-7)^2 + (y-8)^2 = 1$

c. $(x-2)^2 + (y+3)^2 = 36$

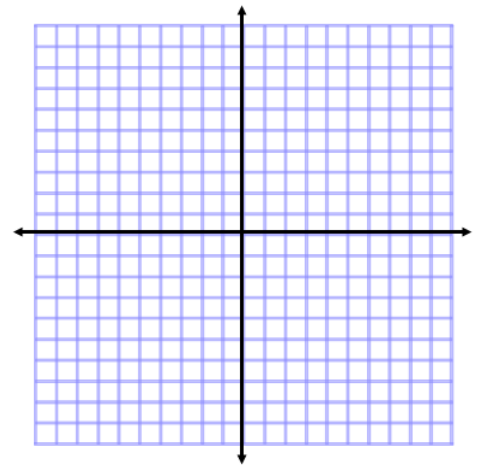
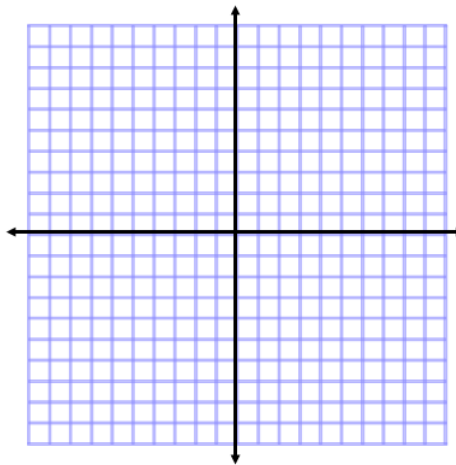
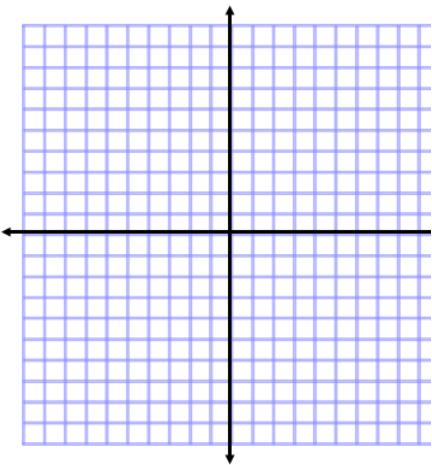

Find the center and radius of the following equations by completing the square:

$y^2 + 4x - 20 - 2y = -x^2$

$16 + x^2 + y^2 - 8x - 6y = 0$

Section 8

1) Using the triangles below, determine the trigonometric ratio. Leave your answers as simplified fractions.

a) $\tan B =$ _____ b) $\cos A =$ _____

c) $\sin F =$ _____ d) $\tan G =$ _____

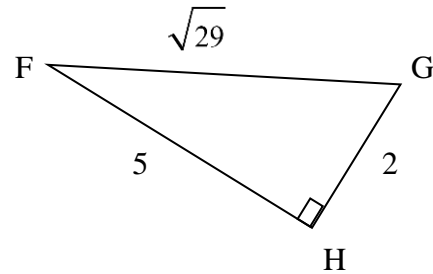
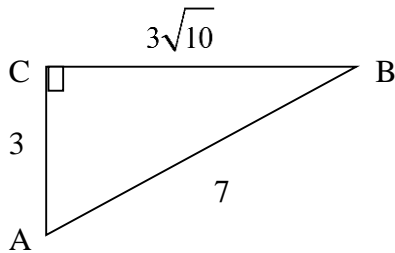

2) Find the marked side of each of the following triangles.

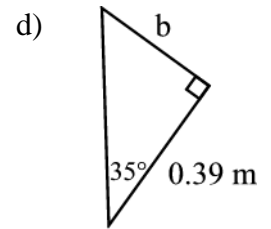
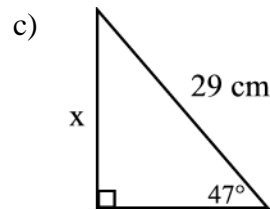
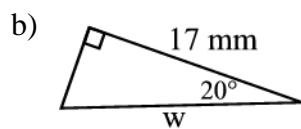
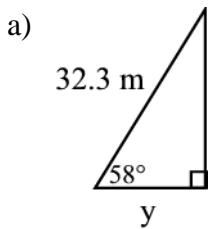

3) Find the value for each of the marked angles.

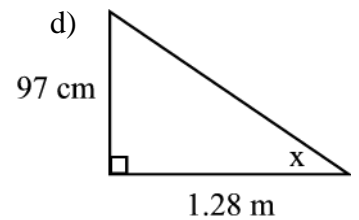
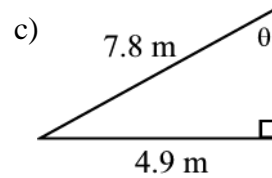
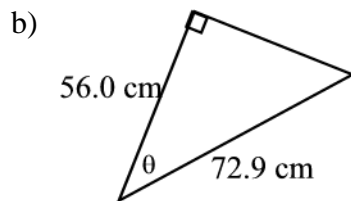
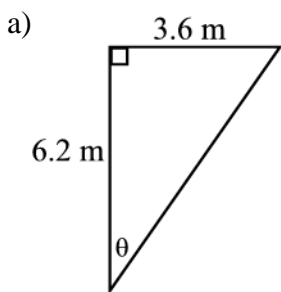

4) A skateboarding ramp is 12 in. high and rises at an angle of 17° . How long is the base of the ramp? What is the length of the ramp? Round your answer to the nearest inch.

5) Joey is walking home from the library. He can walk for 1 mile along the street, then turn right and walk 1.5 miles along another street; or he can cut across a large field straight to his house. At what angle, θ , should he head off from the library, and how far, d , should he cut across the field?

$\theta =$ _____

$d =$ _____

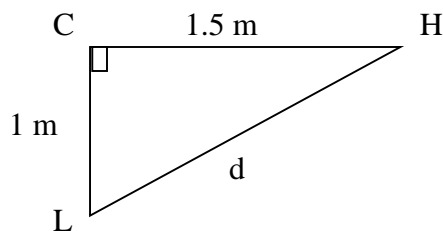

Proofs

- 1) Given: $\angle B$ and $\angle D$ are right angles, $\overline{AB} \cong \overline{CD}$
Prove: $\angle DAC \cong \angle BCA$

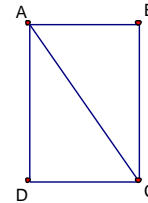

- Given: $\overline{AC} \cong \overline{EC}$, $\overline{BC} \cong \overline{DC}$
Prove: $\angle CBA \cong \angle CDE$

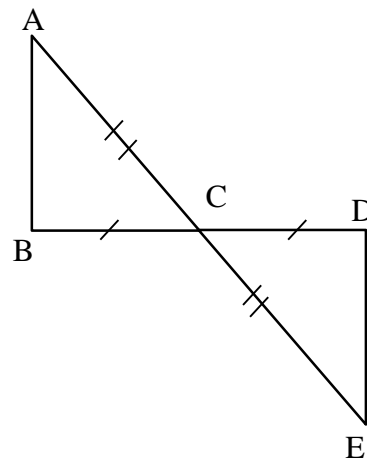

- Given: Q is the midpoint of \overline{PR} , $\square P \cong \square QRT$
Prove: $\triangle SQP \cong \triangle TQR$

