



Lemont High School

800 Porter Street
Lemont, IL 60439
Phone - (630) 257-5838
Fax - (630) 257-7603
Web - www.lhs210.net

Dr. Mary Ticknor, Superintendent
Eric Michaelsen, Principal



Exemplary High Performing School • 2017 National Blue Ribbon Schools Program

Lemont High School Students and Parents/Guardians,

Though the 2019-2020 school year has completed, we know the last few months have not been easy on anyone. During the suspension of in-person instruction, Lemont High School teachers adjusted the curriculum in math courses with a goal of creating the best opportunity for students to achieve success during remote learning. Similarly, we have put together this packet in an effort to provide support for students and parents/guardians during the summer.

Because of the sequential nature of mathematics, Lemont High School's Mathematics Department annually makes supplemental practice available to students in the summer. The concepts included are from prior years of school, and this resource is a tool for students to strengthen readiness for the next school year.

The completion of this packet is not required work for the upcoming school year. However, we believe it is important for students to maintain their skills over the summer, and this never has been more important than now. We recognize students have different motivations for working through this packet:

- Some students acknowledge the need for continued practice through the summer months.
- Some students know additional work during the summer will prepare them for success in the fall.
- Some students seek to challenge the learning of mathematics during the summer to best prepare for the upcoming school year.

Regardless of the motivation, we want to ensure resources are available to support our students. The packet includes a review of basic mathematics, mathematical concepts, and applications of these concepts. Students should use external resources if they are not familiar with some of the concepts included in this packet. Many of the answers for this packet will be available on the school's website by June.

We expect to move forward with instruction as usual in the fall. Therefore, it is our goal for students to be ready for their next courses, and completing this packet will help students with their preparation.

Please contact me at either kyoung@lhs210.net or at (630) 243-3263 with any questions. The Mathematics Department wants to continue to provide tools to practice and strengthen the mastery of mathematics.

Sincerely,

Kathryn A. Young
Mathematics Department Chair

Math II Summer Packet Skills List

1. Identifying components of terms: Constant, Coefficient, Base, Exponents, etc.
2. Exponent Rules
3. Perfect Squares
4. Operations with rational numbers
5. Distributive Property: expressions and equations
6. Determining Factors a number
7. Graphing Linear and Exponential Functions from a table or given $f(x)$ with key features
8. Comparing rate of change between functions
9. Determine function values
10. Transformation of linear and exponential functions using functions notation
11. Linear Regression
12. Solving systems algebraically and graphically
13. Solving systems inequalities algebraically and graphically
14. Describing elements of a two-way table
15. Interpreting two-way tables
16. Pythagorean Theorem
17. Triangles: Congruence, Properties
18. Parallel Properties and Perpendicularity
19. Finding measures of angles
20. Transformations: Translations, Rotations, Reflections
21. Perimeter and Area of Triangles, Circles, Parallelograms
22. Volume of Cylinders and Prisms

1. Identify the terms, coefficients, constants, and factors of $10x^2 - 2x + 4x^2 + 3x - 12$.

2. Explain why the expression $2 \cdot 3^x$ is not equivalent to the expression 6^x .

3. The sum of 4, a , and b is represented by the expression $4 + a + b$. If the sum is negative, which of the following statements must be true?

- a. $a + b$ is greater than 0.
- b. $a + b$ must equal 0.
- c. $a + b$ is less than negative 4.
- d. $a + b$ is greater than 4.

4. Determine whether each expression is a monomial. Write yes or no. Explain your reasoning.

a. 10 : _____

b. $5x + 3$: _____

c. $\frac{7}{x^2}$: _____

d. $6x^2 - x + 9$: _____

e. $24xy^2$: _____

f. j : _____

5. What value can be placed in each box to create a true statement?

a. $(b^{\square})^5 = b^{15}$

b. $g^{\square} \cdot g^6 = g^{11}$

c. $(a^2 \cdot a^{\square})^3 = a^{18}$

6. Given the area of a circle is πr^2 , express the area of the circle with radius $2xy^2$ as a monomial.

7. Express the area of a square with sides of length $3xy^2$ as a monomial.

8. The set of natural numbers are $\{0,1,2,3,\dots\}$. Which of these radicals have natural number solutions?

a. $\sqrt{50}$

b. $\sqrt{25}$

c. $\sqrt{9} + \sqrt{4}$

d. $\sqrt{6}$

9. What must be true about a for the statement $\sqrt{7a} \cdot \sqrt{36} = 7 \cdot 6 = 42$ to be true?

#10 – 15 should be done without a calculator.

10. Which fraction is larger?

$$\frac{2}{3} \quad \text{or} \quad \frac{7}{18}$$

11. Circle any values that are equivalent:

$$\frac{2}{5}, \frac{6}{8}, \frac{6}{15}, \frac{9}{30}, \frac{14}{35}, \frac{20}{50}$$

12. Evaluate: $\frac{1}{3} \cdot \frac{3}{7} \cdot \frac{8}{2}$

13. Evaluate: $\frac{2}{5} + \frac{4}{5}$

14. Evaluate: $\frac{2}{3} - \frac{7}{4}$

15. Convert to an improper fraction: $6\frac{3}{4}$

16. Rebecca, Anna, and Jenna tried to solve the equation $40 - 4(x + 3) = 7x - 5$. They got three different results. Who has the correct result? What mistakes did each of the others make?

<p>Rebecca</p> $40 - 4(x + 3) = 7x - 5$ $40 - 4x + 12 = 7x - 5$ $52 - 4x = 7x - 5$ $52 - 4x + 5 = 7x - 5 + 5$ $57 - 4x = 7x$ $57 - 4x + 4x = 7x + 4x$ $57 = 11x$ $\frac{57}{11} = x$	<p>Anna</p> $40 - 4(x + 3) = 7x - 5$ $40 - 4x + 3 = 7x - 5$ $43 - 4x = 7x - 5$ $39x = 7x - 5$ $39x - 7x = 7x - 5 - 7x$ $32x = -5$ $x = \frac{5}{32}$
<p>Jenna</p> $40 - 4(x + 3) = 7x - 5$ $40 - 4x - 12 = 7x - 5$ $28 - 4x = 7x - 5$ $28 - 4x + 4x = 7x - 5 + 4x$ $28 = 11x - 5$ $28 + 5 = 11x - 5 + 5$ $33 = 11x$ $3 = x$	

17. Simplify the following expressions:

a. $11(a + 5b - 3c)$

b. $7 - 5(y - 11)$

c. $2(3z + 1) - (z - 6)$

18. The factors of $1176 = 2 \cdot 2 \cdot 2 \cdot 3 \cdot 7 \cdot 7 = 2^3 \cdot 3 \cdot 7^2$. Find the factors of the following:

a. 98

b. 810

c. 72

19. Since $64 = 2^6 = 2 \cdot 2 \cdot 2 \cdot 2 \cdot 2 \cdot 2$, paired factors of the number 64 are as follows:

$$1 \cdot 64 = 2^6$$

$$2 \cdot 32 = 2^1 \cdot 2^5$$

$$4 \cdot 16 = 2^2 \cdot 2^4$$

$$8 \cdot 8 = 2^3 \cdot 2^3$$

Find the paired factors of the following numbers that meet the criteria given.

- Two numbers that multiply to 36 whose sum is 15.
- Two numbers that multiply to -21 whose sum is -4 .
- Two numbers that multiply to 60 whose sum is -17 .

20. On the axes to the right, graph each of the following:

$f(x)$ is exponential with an asymptote at $y = 5$

$g(x)$ is linear with a negative slope

$f(x) = g(x)$ at an x -value of $x = 1$

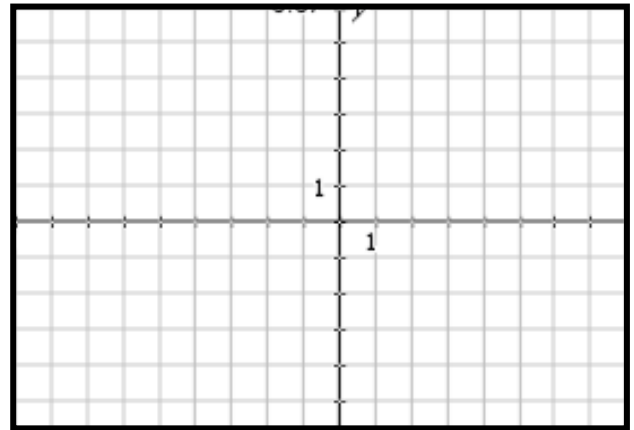

21. Which of the following statements is true about the functions $f(x)$ and $g(x)$?

$$f(x) = 3(2)^x$$

$$g(x) =$$

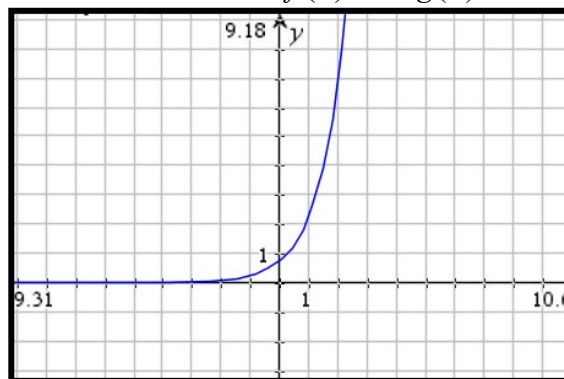

- The y -intercept of function $f(x)$ is less than the y -intercept of the function $g(x)$.
- The y -intercept of function $f(x)$ is greater than the y -intercept of the function $g(x)$.
- The y -intercept of function $f(x)$ is equal to the y -intercept of the function $g(x)$.
- The y -intercepts cannot be determined.

22. Which of the following could be the equation of the line graphed? Circle all that apply.

- a. $f(x) = \frac{1}{2}x + 3$
- b. $f(x) = -400x + 520$
- c. $f(x) = \frac{4}{7}x - 15$
- d. $23x + 16y = 200$
- e. $47y - 27x = 110$
- f. $60x + 81y = -90$

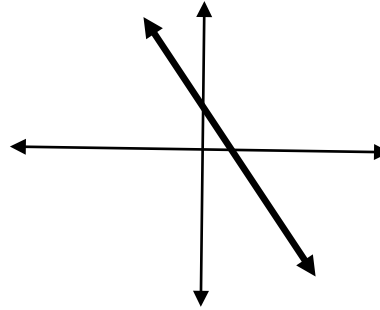

23. If the given table represents a linear function, which of the following is true? Circle all that apply.

- a. The y-intercept of the graph is negative.
- b. The function is decreasing.
- c. The graph of the function has an asymptote at $y = -13$.
- d. $f(2) = -1$

x	$f(x)$
-6	-13
-4	-10
2	-1
4	2

24. Given the table and the graph below, which of the following statements is true about the linear functions $f(x)$ and $g(x)$?

x	$f(x)$
-9	-10
-6	-6
-3	-2
0	2

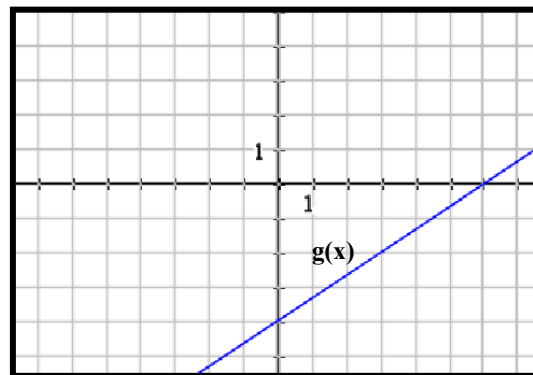

- a. The function $f(x)$ has a greater rate of change than the function $g(x)$.
- b. The function $g(x)$ has a greater rate of change than the function $f(x)$.
- c. The rates of change for both $g(x)$ and $f(x)$ are equal.
- d. The rates of change cannot be determined.

25. Given that $f(x)$ is linear, and $g(x)$ is exponential, which has a greater rate of change in the domain $[1,5]$?

$$g(x) = 2(3)^x$$

x	1	2	3	4	5
$f(x)$	7	12	17	22	27

26. Nicholas and Jacob were having an argument about who could run more miles in one week. On the first day, they both ran one mile. Every day thereafter, Nicholas will run 7 miles per day, and Jacob will double the amount of miles he runs from one day to the next.

a. Create functions for each of these scenarios

b. Which function increases faster for the first few days?

c. Which function has a greater rate of change over this week long time period?

d. If the men planned on running for 1 week, who would run more miles?

27. What is the rate of change for the function $f(x) = 2(3)^{\frac{x}{7}}$ over the interval $[14,35]$?

28. If $f(x) = -3x + 2$ and the domain of f is $\{3,4,5\}$, what is the range of $f(x)$?

29. Answer the following questions for the graph of $f(x)$ and $g(x)$ to the below:

a. What is the values of $f(2)$, $g(3)$, and $g(-6)$?

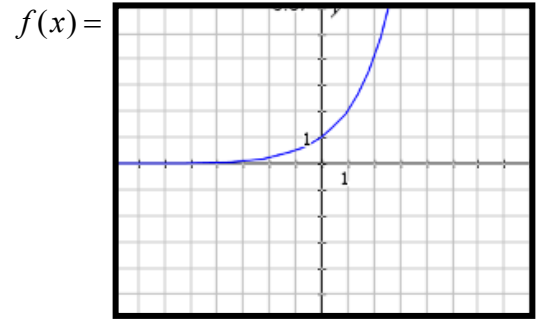

b. What does the point $(0,1)$ represent?

c. Create a scenario for both $f(x)$ and $g(x)$.

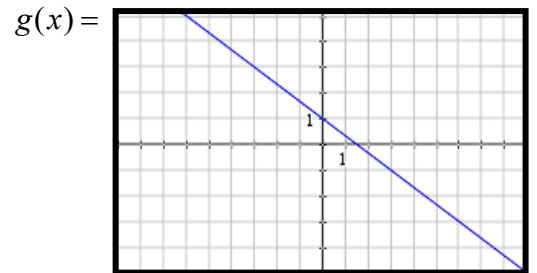

d. Create a function that has a greater rate of change than $g(x)$. Create a scenario for this new function.

e. True or False: $f(-1) > g(3)$

f. True or False: $f(-2)$ is positive.

30. Given the graph of $f(x)$, create $g(x) = f(x) + 3$.

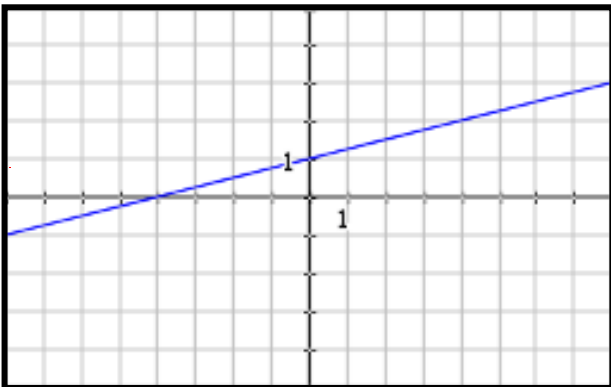

31. Describe the transformation that occurs from $f(x)$ to $g(x)$ in function notation.

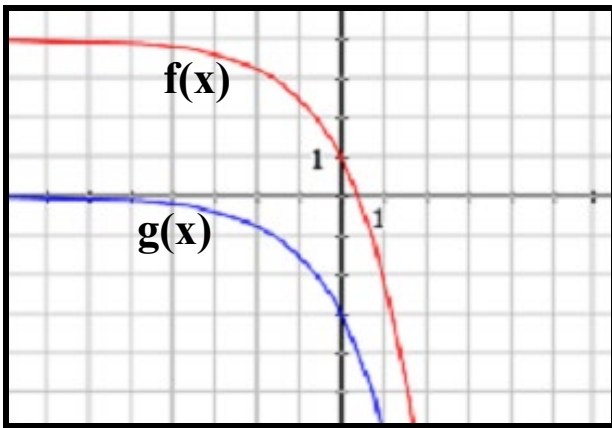

32. The table below shows the study times and test scores for a number of students.

Study Time in minutes	27	22	38	24	12	42	15	34
Test Score	70	65	77	70	58	73	64	71

- Find the line of best fit. _____
- Write a sentence describing the slope. _____
- Find the correlation coefficient. _____ What does this value show about the data?
- If a student studies for an hour, what should her score be? _____
- If a student doesn't study at all, what should his score be? _____

33. Using a graph, find the solution(s) to the following system of equations:

$$y = 3^{x-1}$$

$$y = 2x + 4$$

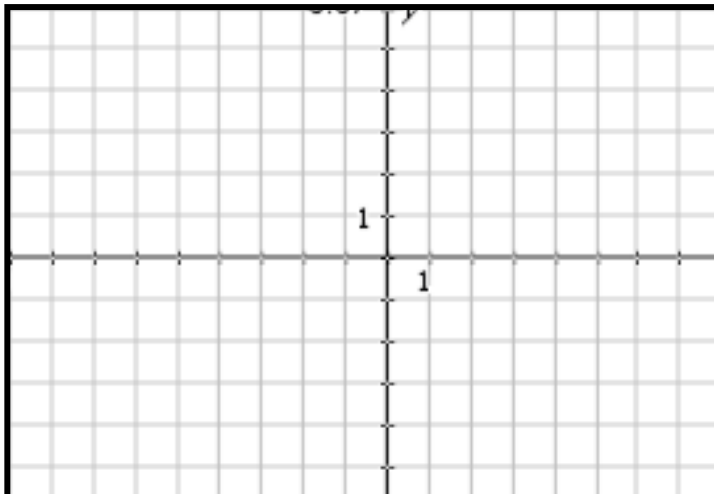

34. Jeff and his friends are planning a trip to a paintball park. Find the cost of lunch and the cost of each paintball. What would be the cost for 400 paintballs and lunch?

Paintball in the park:

- \$25 for 500 paintballs
- \$16 for 200 paintballs
- Lunch is included!

35. A total of \$25,000 is invested in two funds paying 8% and 8.5% simple interest. If the yearly interest earned is \$2060, how much of the \$25,000 is invested at the 8% rate?

36. You find that you have a clogged drain and need to have a plumber come out to fix it. You check with two different companies and find that Perfect Plumbing charges \$50 for a visit, plus \$10 per hour. Drain Demons charges \$25 for a visit, plus \$20 per hour.

- a. After how many hours would it not matter which company you chose?
- b. If you estimate that it will take 2 hours to fix, which company should you go with?

37. Given the inequality $y > -2x + 1$ and $y \leq x + 3$, the point $(-2, 1)$ is _____. Explain your answer.

- a. A solution to both inequalities, _____
- b. A solution to $y > -2x + 1$ only, _____
- c. A solution to $y \leq x + 3$ only, _____
- d. Not a solution of either inequalities, _____

38. Which region (A, B, C, or D) would be shaded to represent the correct solution to the system of linear inequalities

$$\begin{cases} 7y + x \leq -14 \\ 4x - y \leq -4 \end{cases}$$

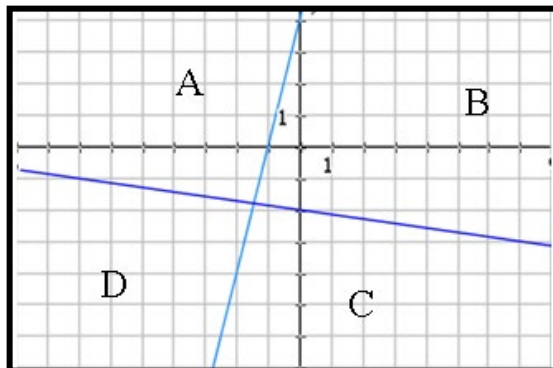

39. To apply for a scholarship, you must have a minimum of 20 hours of community service and a grade-point average of at least 3.75. Another scholarship requires at least 40 hours of community service and a minimum grade-point average of 3.0.

a. Write a system of inequalities to represent the credentials you must have to apply for both scholarships.

b. Graph the system of inequalities.

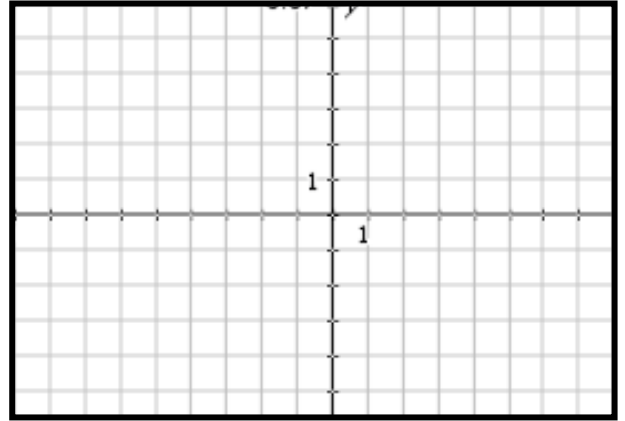

c. If you are eligible for both scholarships, give one possible solution.

40. Angela asked 100 adults which type of music they enjoyed. They could choose Jazz, Rock, Classical or Folk music. The two-way table shows some information about their answers.

	Jazz	Rock	Classical	Folk	Total
Men	12		19	4	52
Women		23			
Total	21			11	100

a. Complete the two-way table.

b. How many did not choose Classical music?

41. A soda company conducted a taste test for three different kinds of soda that it makes. It surveyed 200 people in each age group about their favorite flavor and the results are shown in the table below.

Age	Soda A	Soda B	Soda C
Under 20	30	44	126
20 to 39	67	75	58
40 to 59	88	78	34
60 and over	141	49	10

a. How many people in all were surveyed for the taste test?

b. How many participants chose Soda A?

c. How many participants chose Soda C who were also 20 years or older?

42. An airline wants to determine if passengers not checking luggage is related to people being on business trips. Data for 1000 random passengers at an airport was collected and summarized in the table below.

	Checked Baggage	No Checked Baggage
Traveling for business	103	387
Not traveling for business	216	294

- How many passengers travelled for business?
- How many passengers traveling did not check baggage?
- Of the passengers traveling for business, how many did not check baggage?

43. If a right triangle has legs of 4 in and 5 in, use the Pythagorean Theorem to find the length of the hypotenuse.

44. A tent is supported by a guy rope tied to a stake, as shown in the diagram. What is the length of the rope?

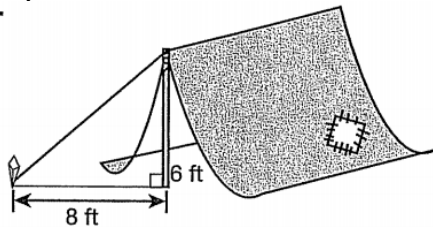

45. Julie is planning a right triangular garden. She marked two sides that measure 24 feet and 25 feet. What is the length of side labelled n ?

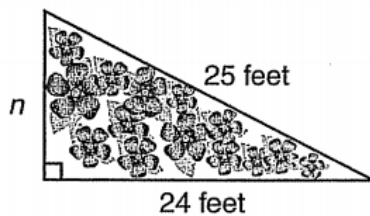

46. An inclined ramp rises 4 meters over a horizontal distance of 9 meters. How long is the ramp?

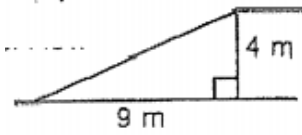

47. In each of the figures below, write a congruence statement for the figures AND the postulate that proves that the triangles are congruent.

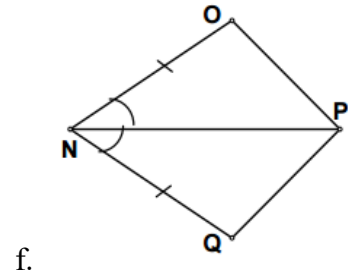
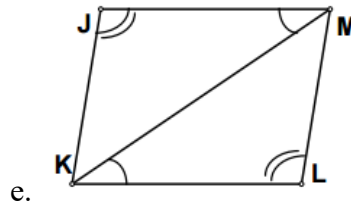
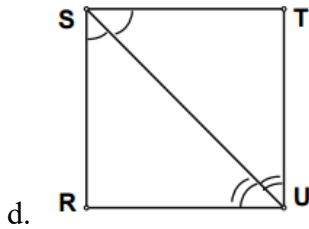
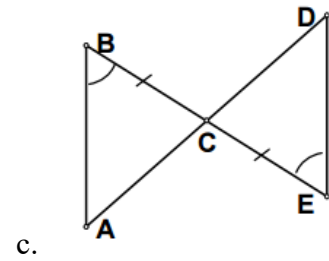
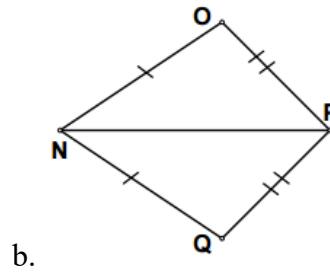
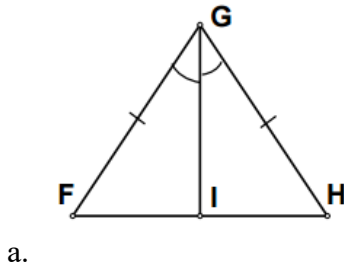

48. Use the following diagram to make conjectures when given the following:

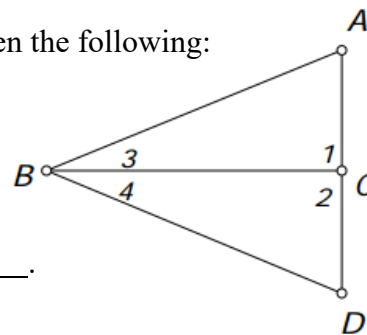

- If $BC \perp AD$, then _____.
- If \overline{BC} bisects $\angle ABD$, then _____.
- If C is the midpoint of \overline{AD} , then _____.

49. Given the information stated in each exercise, you are to prove $\triangle ABC \cong \triangle DBC$. Without doing the proof, state the method you would use to prove them congruent. (SSS, SAS, ASA).

- a. Given: $AB = BD$; $AC = CD$ _____
- b. Given: $\angle ABC \cong \angle DBC$; $AB = BD$ _____
- c. Given: $\angle 1$ & $\angle 2$ are right angles; $\angle 3 \cong \angle 4$ _____

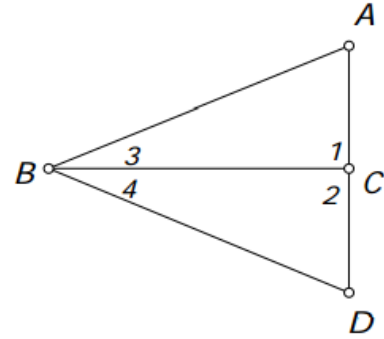

50. In a triangle, one angle measures 46° while another measures 108° . What is the measure of the remaining angle?

51. Is it possible for a triangle to have angle measures of 1° , 2° , and 177° ? Explain why or why not.

52. Solve for x in each figure below:

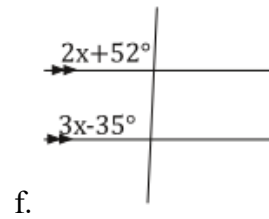
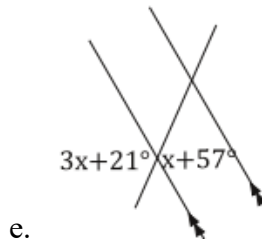
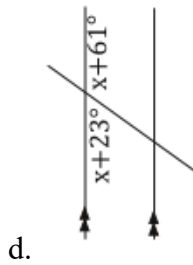
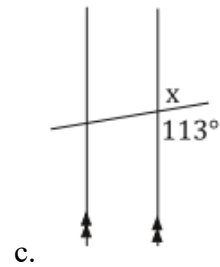
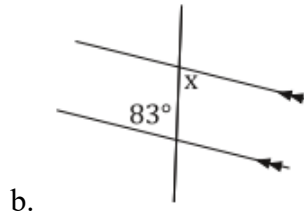
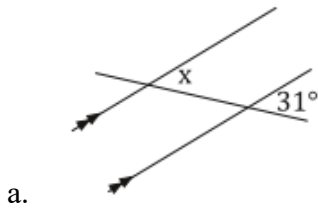

53. In the following diagram, $m\angle BCD = (x + 26)^\circ$ and $m\angle BFG = (2x + 24)^\circ$. Find $m\angle BFG$.

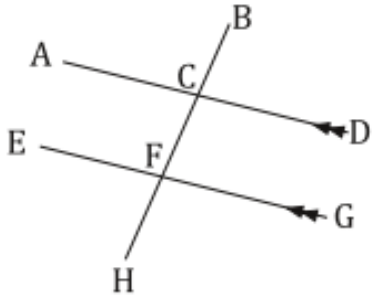

54. Find the equations of the linear function that is perpendicular to $f(x) = \frac{2}{3}x + 5$ and passing through the point $(3, 2)$.

55. Find the equations of the linear function that is parallel to $2x - 3y = 6$ and passing through the point $(0, 3)$.

56. Find the equations of the linear function that is perpendicular to $f(x) = -7$ and passing through the point $(-2, 5)$.

57. Find the equations of the perpendicular bisector through the segment with endpoints $(-10, -1)$ and $(5, 9)$.

58. Use what you know about the sum of the angles in a triangle together with the properties of supplementary angles to calculate the missing angles in the figure below.

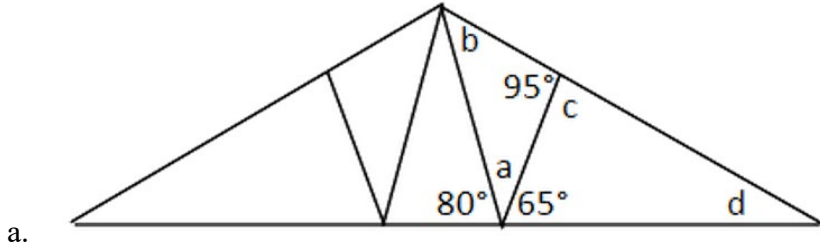

59. Use what you know about the sum of the angles in a triangle together with the properties of supplementary angles to calculate the SUM of angles b , c , and e in the figures below.

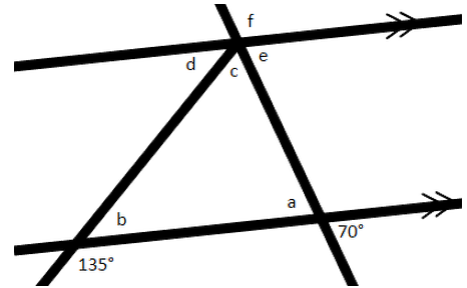

60. Draw a reflection of the figure shown over the x -axis.

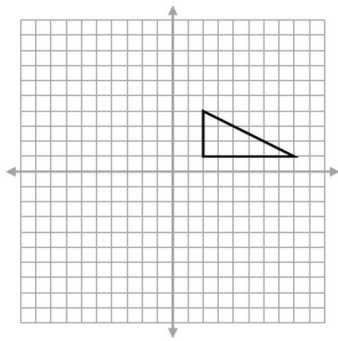

61. Draw a reflection of the figure shown over the y -axis.

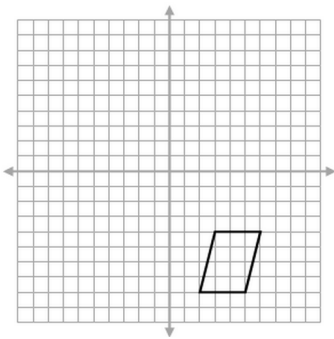

62. Draw a rotation of 90° clockwise about the origin of the figure shown.

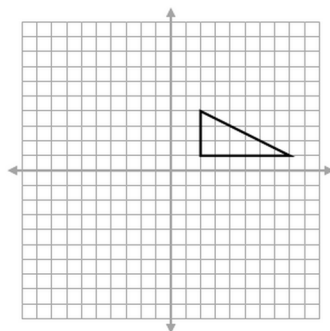

63. The coordinates of rectangle ABCD are $(2, -2)$ $(8, -2)$ $(8, -5)$ $(2, -5)$. What are the coordinates of rectangle A'B'C'D' after a translation of $(-6, 7)$.

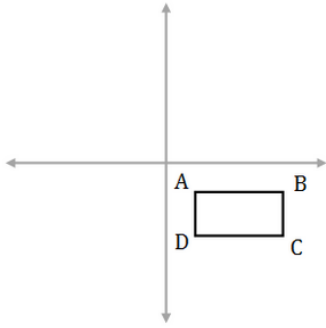

64. The coordinates of $\triangle EFG$ are $(-3, 2)$ $(3, 11)$ $(11, 2)$. What are the coordinates of rectangle $\triangle E'F'G'$ after a horizontal reflection?

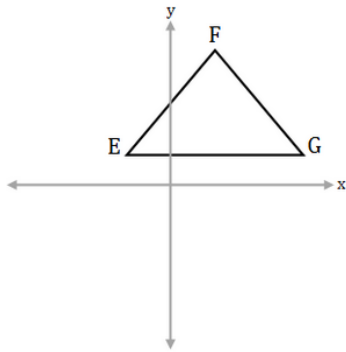

65. Describe the sequence of transformations from ABC to A'B'C'.

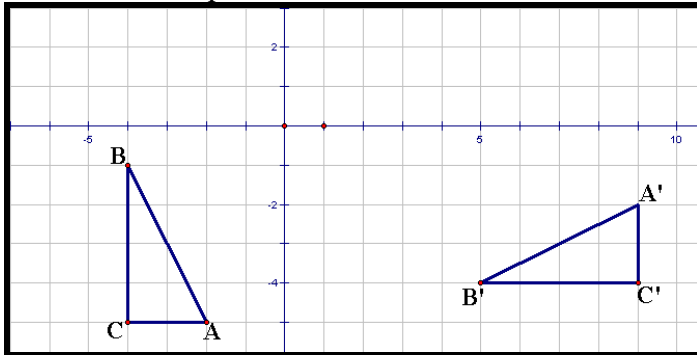

66. Find the perimeter of a square with each side measuring 9 meters.

67. Find the length of one side of a square whose perimeter is 52 feet.

68. Find the length of the missing side of the shape below.

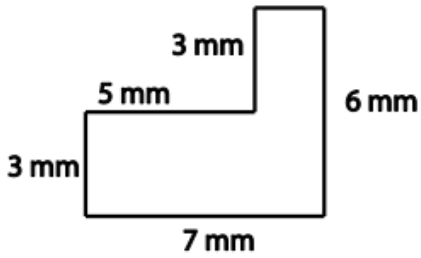

69. A yoga mat is rectangular and measures 72 inches by 24 inches. Find the area of the mat.

70. Maddison calculates the area of a rectangle to be 56 meters. What is wrong with her answer?

71. The perimeter of a rectangle is 66. The length is twice the width. Find the length and width of the rectangle.

72. Find the perimeter of the shape shown below.

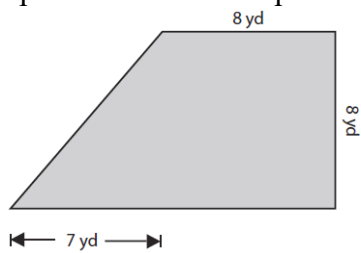

73. Find the perimeter of the shape shown below.

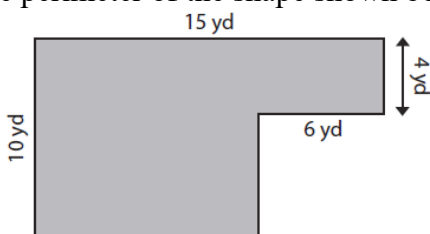

74. Find the area of the shaded region.

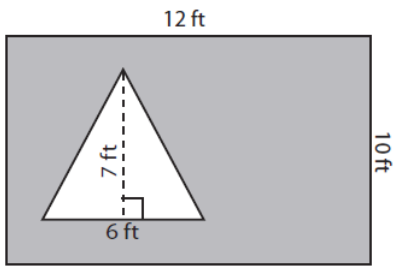

75. Find the area of the shape shown below.

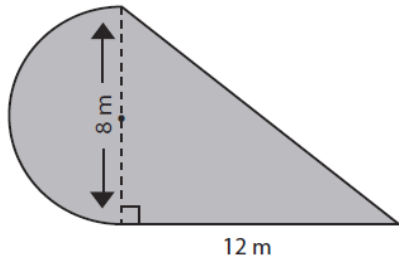

76. Copy the measurements given onto the net of the solid.

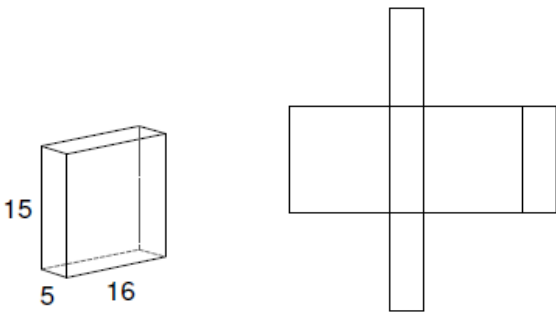

77. Copy the measurements given onto the net of the solid.

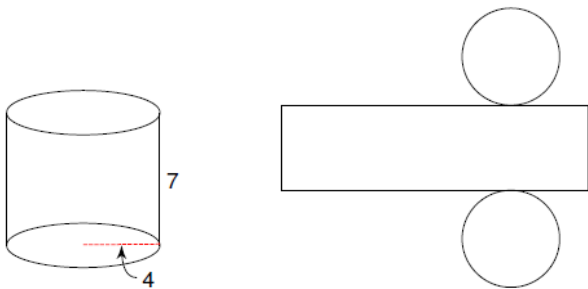

78. Find the volume of each figure shown below:

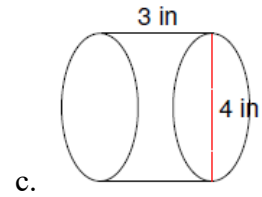
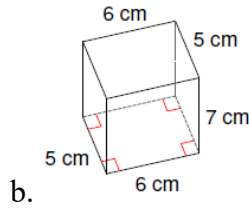
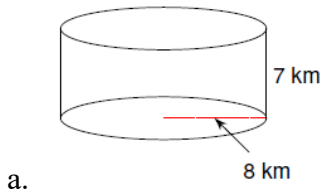

79. This set of stairs is positioned on a garage floor, against a wall.

- a. The stairs are to be painted. Find the area that needs to be painted.

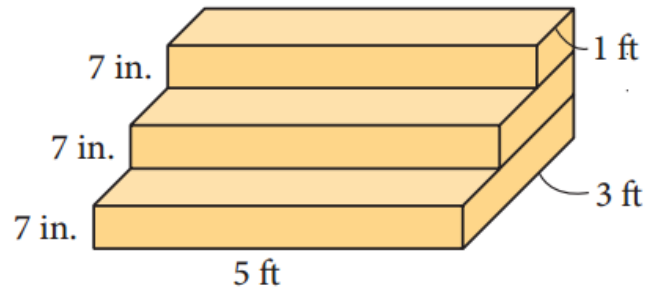

- b. If 1L of paint covers 11.2ft^2 , how many liters of paint are needed to paint the stairs?

80. The exterior walls of a barn are to be painted. The barn is in the shape of a rectangular prism with an isosceles triangular prism for a roof.

- a. Find the total area to be painted.

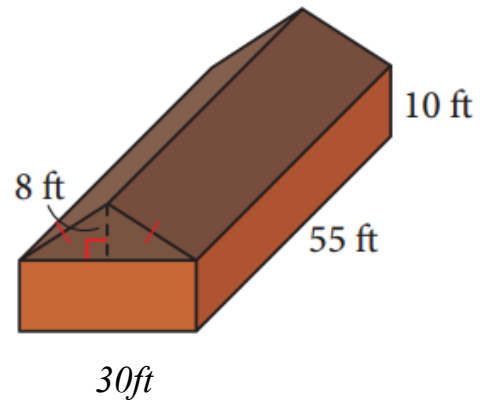

- b. The paint is sold in 1 gallon cans. On the first coat of paint, a gallon of paint will cover an area of 400ft^2 . How many gallons of paint are needed for the first coat?