

Greetings **Pre-Calculus** Students! We hope you are safe and well with your families!
Here is the lesson plan for this week:

Goals for this week

Learning Objectives:

Students will be able to:

- Identify and apply trigonometric ratios in a right triangle
- Solve for a side in a right triangle using trigonometric ratios
- Solve for an angle in a right triangle using trigonometric ratios
- Solve right triangle word problems involving angles of elevation and depression

MA Secondary Prerequisite Content Standards: G-SRT.C

Literacy Objectives:

Students will be able to:

1. to compute, interpret and explain numbers
2. to read, break down, and solve a word problem

<https://www.bpsma.org/schools/brockton-high-school/about-us/mission-literacy-charts>

This assignment is for the week, use your time wisely. You do not have to complete this in one sitting.

Step 1: Log on to CLEVER, then use the link to access Khan Academy. See detailed login instructions below.

Once you have logged in to Khan Academy through CLEVER, copy and paste the link below on your browser to access this week's material. Course: **Trigonometry**: Lesson: **Trigonometry with Right Triangles** (first 4 topics).

Link to lesson: <https://www.khanacademy.org/math/trigonometry/trigonometry-right-triangles#trig-solve-for-a-side>

Complete the practice problems associated with each topic. Watch the accompanying videos for guidance within each topic.

Topic 1: Introduction to the Trigonometric Ratios:

Topic 2: Solving for a Side in a Right Triangle Using the Trigonometric Ratios:

Topic 3: Solving for an Angle in a Right Triangle Using the Trigonometric Ratios:

Topic 4: Modeling With Right Triangles

Log-in Information

1. Log-in to Clever
Username: 6-digit BHS school ID # @bpsma.org
Password: Date of birth bps 1920
Example: Student (Michael) with ID #:123456
Date of birth: January 1st, 2000
Username: 123456@bpsma.org
Password: 01012000bps1920



Once you have logged in to CLEVER, click on the Khan Academy icon to log in to your Khan Academy account. You will find this icon on your math teacher's page, or under Enrichment. If you do not have a Khan Academy account, you can create one here.

Additional Support

Email:

- Please email your math teacher with specific questions.

Office Hours:

- Here is a list of math teachers' office hours. Your teacher is available to help you during their scheduled office hours.
[BHS Math Department Office Hours](#)

Printable Resources (Optional)

Lippman, D., & Rasmussen, M. (2017). *Precalculus: An Investigation of Functions*. Minneapolis, MN: Open Textbook Library.

Section 5.5 Right Triangle Trigonometry

In section 5.3 we were introduced to the sine and cosine function as ratios of the sides of a triangle drawn inside a circle, and spent the rest of that section discussing the role of those functions in finding points on the circle. In this section, we return to the triangle, and explore the applications of the trigonometric functions to right triangles where circles may not be involved.

Recall that we defined sine and cosine as

$$\sin(\theta) = \frac{y}{r}$$

$$\cos(\theta) = \frac{x}{r}$$

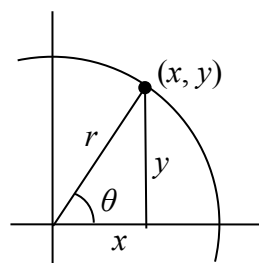

Separating the triangle from the circle, we can make equivalent but more general definitions of the sine, cosine, and tangent on a right triangle. On the right triangle, we will label the hypotenuse as well as the side opposite the angle and the side adjacent (next to) the angle.

Right Triangle Relationships

Given a right triangle with an angle of θ

$$\sin(\theta) = \frac{\text{opposite}}{\text{hypotenuse}}$$

$$\cos(\theta) = \frac{\text{adjacent}}{\text{hypotenuse}}$$

$$\tan(\theta) = \frac{\text{opposite}}{\text{adjacent}}$$

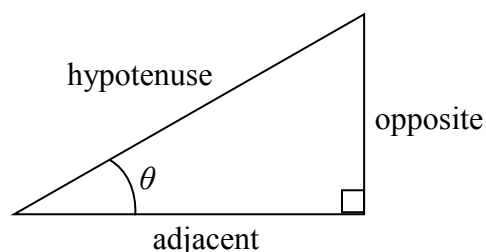

A common mnemonic for remembering these relationships is SohCahToa, formed from the first letters of “Sine is opposite over hypotenuse, Cosine is adjacent over hypotenuse, Tangent is opposite over adjacent.”

Example 1

Given the triangle shown, find the value for $\cos(\alpha)$.

The side adjacent to the angle is 15, and the hypotenuse of the triangle is 17, so

$$\cos(\alpha) = \frac{\text{adjacent}}{\text{hypotenuse}} = \frac{15}{17}$$

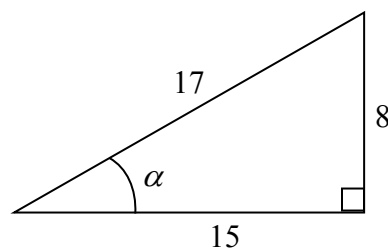

When working with general right triangles, the same rules apply regardless of the orientation of the triangle. In fact, we can evaluate the sine and cosine of either of the two acute angles in the triangle.

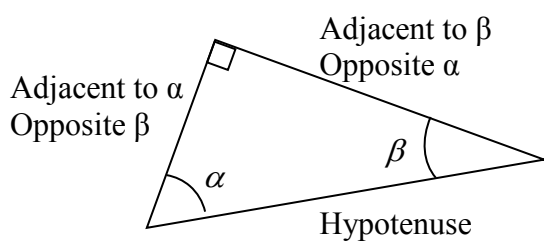

Example 2

Using the triangle shown, evaluate $\cos(\alpha)$, $\sin(\alpha)$, $\cos(\beta)$, and $\sin(\beta)$.

$$\cos(\alpha) = \frac{\text{adjacent to } \alpha}{\text{hypotenuse}} = \frac{3}{5}$$

$$\sin(\alpha) = \frac{\text{opposite } \alpha}{\text{hypotenuse}} = \frac{4}{5}$$

$$\cos(\beta) = \frac{\text{adjacent to } \beta}{\text{hypotenuse}} = \frac{4}{5}$$

$$\sin(\beta) = \frac{\text{opposite } \beta}{\text{hypotenuse}} = \frac{3}{5}$$

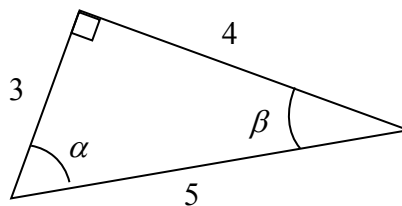

Try it Now

1. A right triangle is drawn with angle α opposite a side with length 33, angle β opposite a side with length 56, and hypotenuse 65. Find the sine and cosine of α and β .

You may have noticed that in the above example that $\cos(\alpha) = \sin(\beta)$ and $\cos(\beta) = \sin(\alpha)$. This makes sense since the side opposite α is also adjacent to β . Since the three angles in a triangle need to add to π , or 180 degrees, then the other two angles must add to $\frac{\pi}{2}$, or 90 degrees, so $\beta = \frac{\pi}{2} - \alpha$, and $\alpha = \frac{\pi}{2} - \beta$. Since $\cos(\alpha) = \sin(\beta)$, then $\cos(\alpha) = \sin\left(\frac{\pi}{2} - \alpha\right)$.

Cofunction Identities

The **cofunction identities** for sine and cosine are:

$$\cos(\theta) = \sin\left(\frac{\pi}{2} - \theta\right) \qquad \sin(\theta) = \cos\left(\frac{\pi}{2} - \theta\right)$$

In the previous examples, we evaluated the sine and cosine on triangles where we knew all three sides of the triangle. Right triangle trigonometry becomes powerful when we start looking at triangles in which we know an angle but don't know all the sides.

Example 3

Find the unknown sides of the triangle pictured here.

$$\text{Since } \sin(\theta) = \frac{\text{opposite}}{\text{hypotenuse}}, \quad \sin(30^\circ) = \frac{7}{b}.$$

From this, we can solve for the side b .

$$b \sin(30^\circ) = 7$$

$$b = \frac{7}{\sin(30^\circ)}$$

To obtain a value, we can evaluate the sine and simplify

$$b = \frac{7}{\frac{1}{2}} = 14$$

To find the value for side a , we could use the cosine, or simply apply the Pythagorean Theorem:

$$a^2 + 7^2 = b^2$$

$$a^2 + 7^2 = 14^2$$

$$a = \sqrt{147}$$

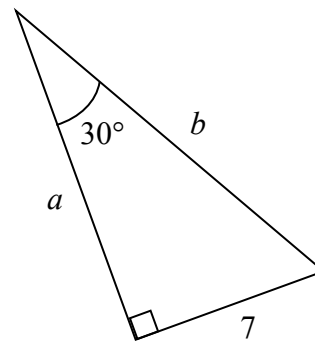

Notice that if we know at least one of the non-right angles of a right triangle and one side, we can find the rest of the sides and angles.

Try it Now

2. A right triangle has one angle of $\frac{\pi}{3}$ and a hypotenuse of 20. Find the unknown sides and angles of the triangle.
-
-

Example 4

To find the height of a tree, a person walks to a point 30 feet from the base of the tree, and measures the angle from the ground to the top of the tree to be 57 degrees. Find the height of the tree.

We can introduce a variable, h , to represent the height of the tree. The two sides of the triangle that are most important to us are the side opposite the angle, the height of the tree we are looking for, and the adjacent side, the side we are told is 30 feet long.

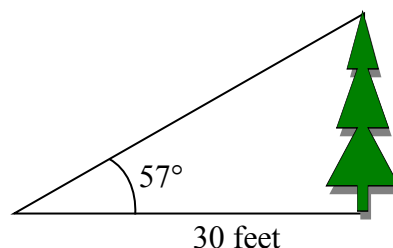

The trigonometric function which relates the side opposite of the angle and the side adjacent to the angle is the tangent.

$$\tan(57^\circ) = \frac{\text{opposite}}{\text{adjacent}} = \frac{h}{30}$$

Solving for h ,

$$h = 30 \tan(57^\circ)$$

Using technology, we can approximate a value

$$h = 30 \tan(57^\circ) \approx 46.2 \text{ feet}$$

The tree is approximately 46 feet tall.

Example 5

A person standing on the roof of a 100 foot tall building is looking towards a skyscraper a few blocks away, wondering how tall it is. She measures the angle of declination from the roof of the building to the base of the skyscraper to be 20 degrees and the angle of inclination to the top of the skyscraper to be 42 degrees.

To approach this problem, it would be good to start with a picture. Although we are interested in the height, h , of the skyscraper, it can be helpful to also label other unknown quantities in the picture – in this case the horizontal distance x between the buildings and a , the height of the skyscraper above the person.

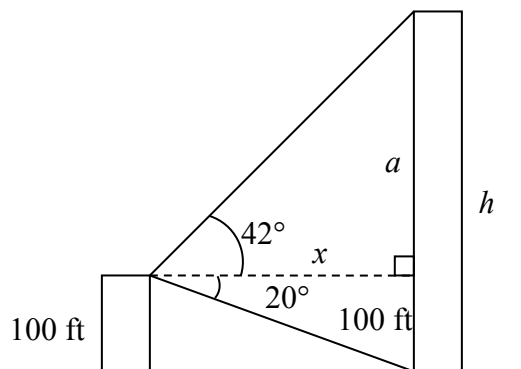

To start solving this problem, notice we have two right triangles. In the top triangle, we know one angle is 42 degrees, but we don't know any of the sides of the triangle, so we don't yet know enough to work with this triangle.

In the lower right triangle, we know one angle is 20 degrees, and we know the vertical height measurement of 100 ft. Since we know these two pieces of information, we can solve for the unknown distance x .

$$\tan(20^\circ) = \frac{\text{opposite}}{\text{adjacent}} = \frac{100}{x} \quad \text{Solving for } x$$

$$x \tan(20^\circ) = 100$$

$$x = \frac{100}{\tan(20^\circ)}$$

Now that we have found the distance x , we know enough information to solve the top right triangle.

$$\tan(42^\circ) = \frac{\text{opposite}}{\text{adjacent}} = \frac{a}{x} = \frac{a}{100 / \tan(20^\circ)}$$

$$\tan(42^\circ) = \frac{a \tan(20^\circ)}{100}$$

$$100 \tan(42^\circ) = a \tan(20^\circ)$$

$$\frac{100 \tan(42^\circ)}{\tan(20^\circ)} = a$$

Approximating a value,

$$a = \frac{100 \tan(42^\circ)}{\tan(20^\circ)} \approx 247.4 \text{ feet}$$

Adding the height of the first building, we determine that the skyscraper is about 347 feet tall.

Important Topics of This Section

SOH CAH TOA

Cofunction identities

Applications with right triangles

Try it Now Answers

$$1. \sin(\alpha) = \frac{33}{65} \quad \cos(\alpha) = \frac{56}{65} \quad \sin(\beta) = \frac{56}{65} \quad \cos(\beta) = \frac{33}{65}$$

$$2. \cos\left(\frac{\pi}{3}\right) = \frac{\text{adjacent}}{\text{hypoteuse}} = \frac{\text{Adj}}{20} \quad \text{so, adjacent} = 20 \cos\left(\frac{\pi}{3}\right) = 20\left(\frac{1}{2}\right) = 10$$

$$\sin\left(\frac{\pi}{3}\right) = \frac{\text{Opposite}}{\text{hypoteuse}} = \frac{\text{Opp}}{20} \quad \text{so, opposite} = 20 \sin\left(\frac{\pi}{3}\right) = 20\left(\frac{\sqrt{3}}{2}\right) = 10\sqrt{3}$$

Missing angle = $180 - 90 - 60 = 30$ degrees or $\frac{\pi}{6}$.

Section 5.5 Exercises

Note: pictures may not be drawn to scale.

In each of the triangles below, find $\sin(A)$, $\cos(A)$, $\tan(A)$, $\sec(A)$, $\csc(A)$, $\cot(A)$.

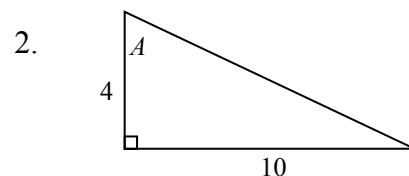
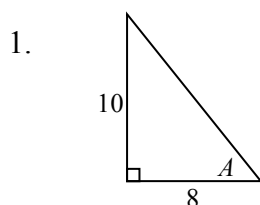

In each of the following triangles, solve for the unknown sides and angles.

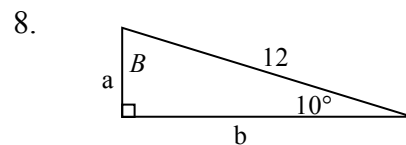
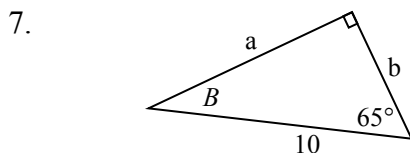
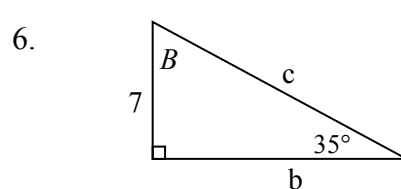
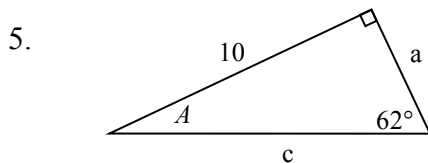
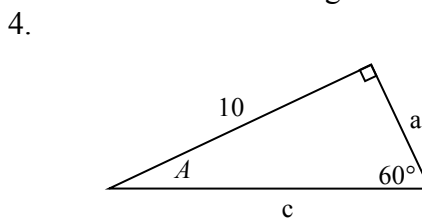
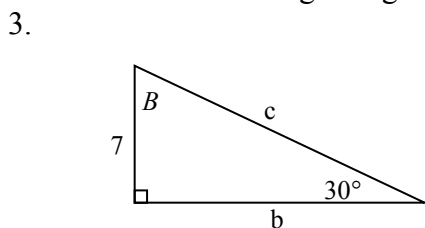

9. A 33-ft ladder leans against a building so that the angle between the ground and the ladder is 80° . How high does the ladder reach up the side of the building?

10. A 23-ft ladder leans against a building so that the angle between the ground and the ladder is 80° . How high does the ladder reach up the side of the building?

11. The angle of elevation to the top of a building in New York is found to be 9° from the ground at a distance of 1 mile from the base of the building. Using this information, find the height of the building.
12. The angle of elevation to the top of a building in Seattle is found to be 2° from the ground at a distance of 2 miles from the base of the building. Using this information, find the height of the building.
13. A radio tower is located 400 feet from a building. From a window in the building, a person determines that the angle of elevation to the top of the tower is 36° and that the angle of depression to the bottom of the tower is 23° . How tall is the tower?
14. A radio tower is located 325 feet from a building. From a window in the building, a person determines that the angle of elevation to the top of the tower is 43° and that the angle of depression to the bottom of the tower is 31° . How tall is the tower?
15. A 200 foot tall monument is located in the distance. From a window in a building, a person determines that the angle of elevation to the top of the monument is 15° and that the angle of depression to the bottom of the tower is 2° . How far is the person from the monument?
16. A 400 foot tall monument is located in the distance. From a window in a building, a person determines that the angle of elevation to the top of the monument is 18° and that the angle of depression to the bottom of the tower is 3° . How far is the person from the monument?
17. There is an antenna on the top of a building. From a location 300 feet from the base of the building, the angle of elevation to the top of the building is measured to be 40° . From the same location, the angle of elevation to the top of the antenna is measured to be 43° . Find the height of the antenna.
18. There is lightning rod on the top of a building. From a location 500 feet from the base of the building, the angle of elevation to the top of the building is measured to be 36° . From the same location, the angle of elevation to the top of the lightning rod is measured to be 38° . Find the height of the lightning rod.
19. Find the length x .
20. Find the length x .

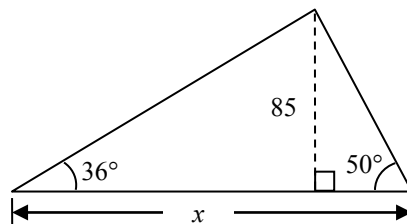
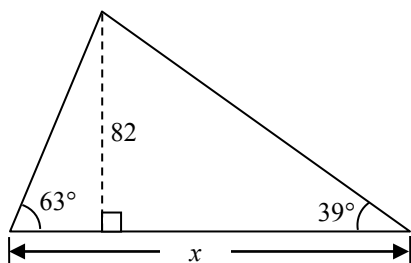

21. Find the length x .

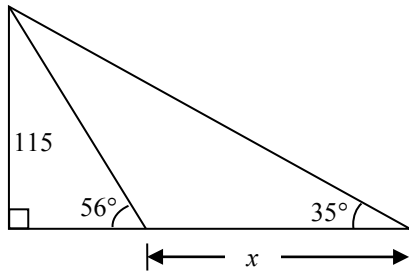

22. Find the length x .

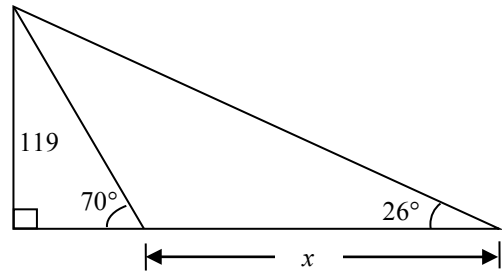

23. A plane is flying 2000 feet above sea level toward a mountain. The pilot observes the top of the mountain to be 18° above the horizontal, then immediately flies the plane at an angle of 20° above horizontal. The airspeed of the plane is 100 mph. After 5 minutes, the plane is directly above the top of the mountain. How high is the plane above the top of the mountain (when it passes over)? What is the height of the mountain? [UW]

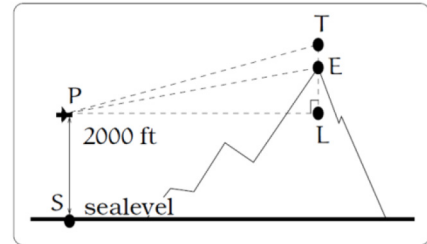

24. Three airplanes depart SeaTac Airport. A United flight is heading in a direction 50° counterclockwise from east, an Alaska flight is heading 115° counterclockwise from east and a Delta flight is heading 20° clockwise from east. [UW]

- Find the location of the United flight when it is 20 miles north of SeaTac.
- Find the location of the Alaska flight when it is 50 miles west of SeaTac.
- Find the location of the Delta flight when it is 30 miles east of SeaTac.

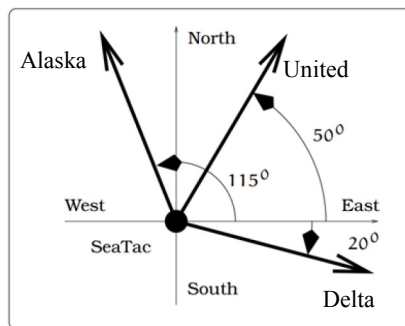

(a) The flight paths of three airplanes

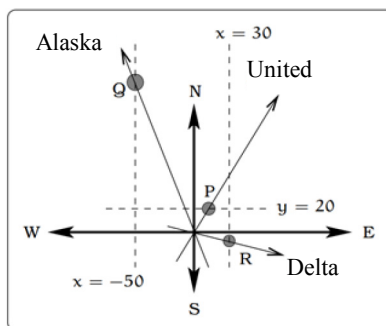

(b) Modeling the paths of each flight

25. The crew of a helicopter needs to land temporarily in a forest and spot a flat piece of ground (a clearing in the forest) as a potential landing site, but are uncertain whether it is wide enough. They make two measurements from A (see picture) finding $\alpha = 25^\circ$ and $\beta = 54^\circ$. They rise vertically 100 feet to B and measure $\gamma = 47^\circ$. Determine the width of the clearing to the nearest foot. [UW]

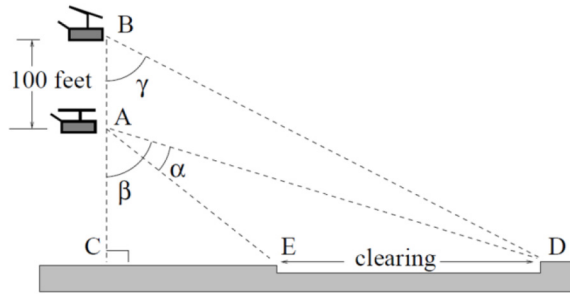

26. A Forest Service helicopter needs to determine the width of a deep canyon. While hovering, they measure the angle $\gamma = 48^\circ$ at position B (see picture), then descend 400 feet to position A and make two measurements: $\alpha = 13^\circ$ (the measure of $\angle EAD$), $\beta = 53^\circ$ (the measure of $\angle CAD$). Determine the width of the canyon to the nearest foot. [UW]

