

Distance Learning Packet

Week 2&3

Name:

(First and Last Name)

Teacher: _____

KINDERGARTEN

(

(

(

Kindergarten

Distance Learning Packet

Weeks 2 & 3

Dear grown-up,

Please help your child complete these pages. Do not hesitate to reach out to us if you have questions or we can help support you in any way through this challenging time.

Sincerely,

Miss Smith and Mrs Wilkinson

()

()

()

Name _____

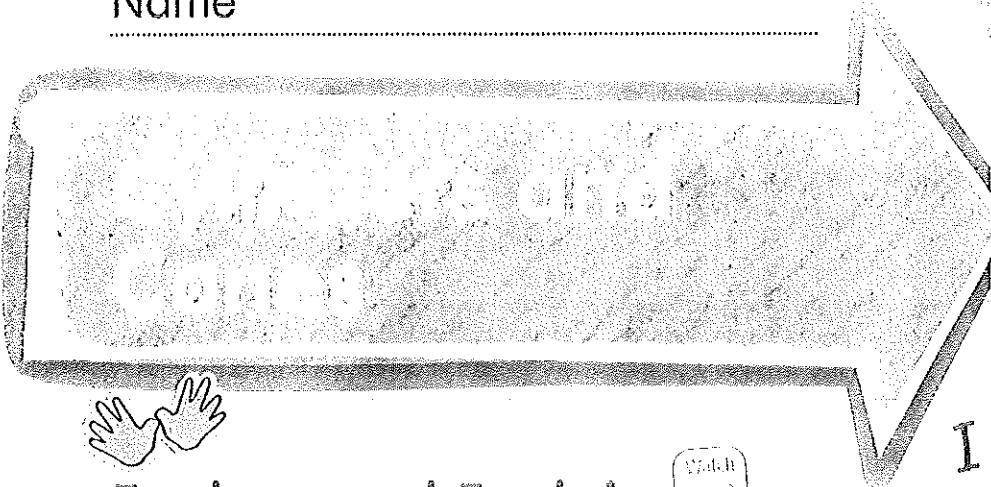

Lesson 2

ESSENTIAL QUESTION

How do I identify and compare three-dimensional shapes?



Explore and Explain



I like cones!

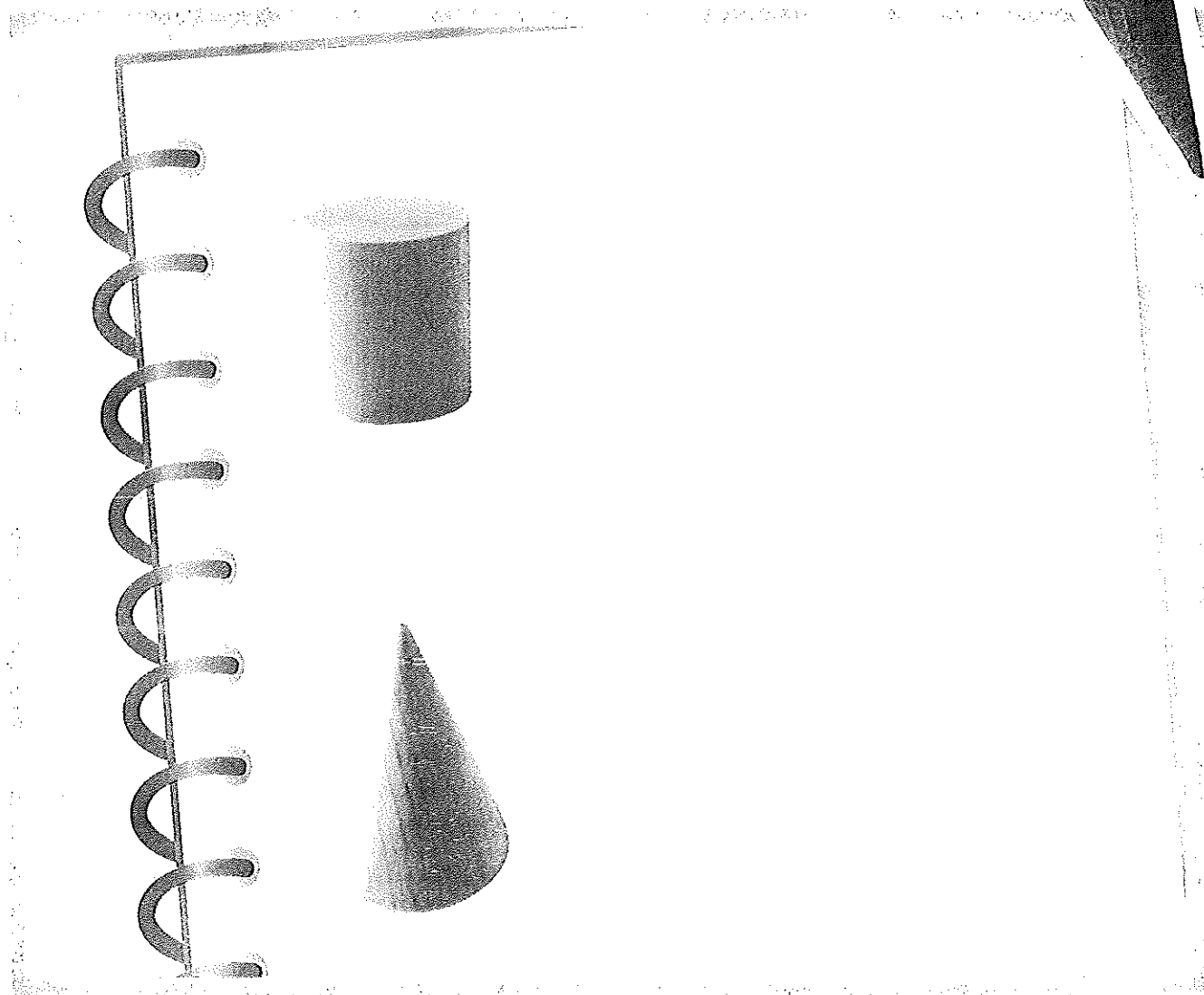

Copyright © The McGraw-Hill Companies, Inc. (t) Photodisc/PunchStock; (c, b) The McGraw-Hill Companies



Teacher Directions: Go on a three-dimensional shape walk around the classroom. Identify objects that are shaped like cylinders and cones. Draw a picture of one of the objects beside the matching shape. Tell whether the objects are solid or flat.

See and Show

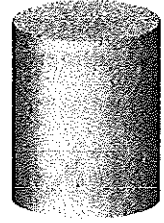
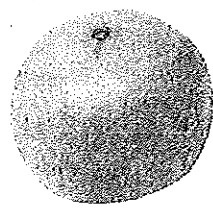
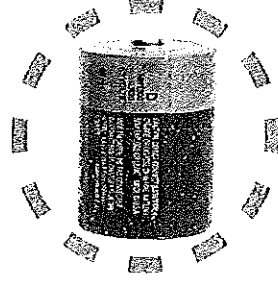

1 cylinder

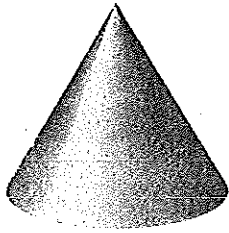
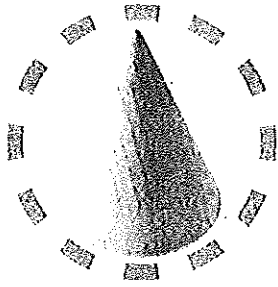
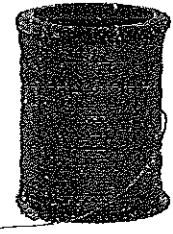

2 cone

3

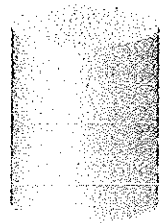
4

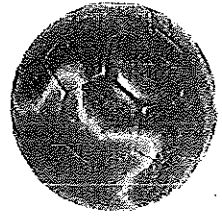

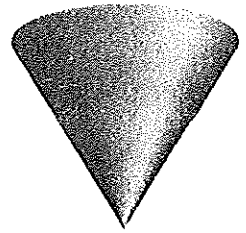
Directions: 1–2. Name the shape above the objects. Describe it. Compare it to the shapes of the objects below it. Trace the circle around the matching shape. 3–4. Name the first shape in the row. Describe it. Compare it to the shapes of the objects in the row. Circle the matching shape.

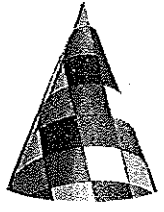
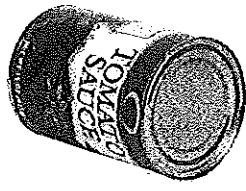
Copyright © The McGraw-Hill Companies, Inc. (1 to r, t to b) (2) Mark Steinmetz/The McGraw-Hill Companies, Inc.; (3) The McGraw-Hill Companies; (4, 5, 6, 7) Mark Steinmetz/The McGraw-Hill Companies, Inc.; (8) The McGraw-Hill Companies, Inc./Ken Cavanagh Photographer; (9) Comstock/PunchStock; (10) Mark Steinmetz/The McGraw-Hill Companies, Inc.

Name _____

On My Own

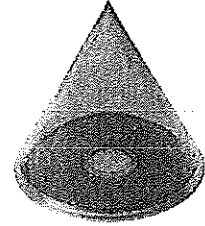
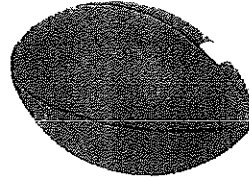
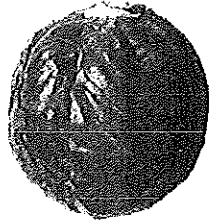
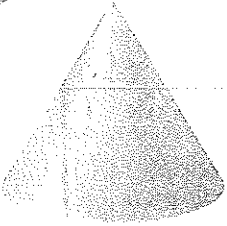
5



6

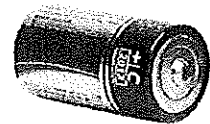
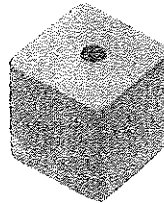
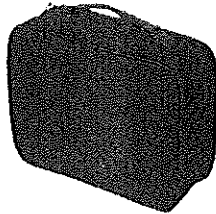
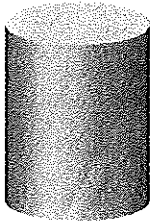

7

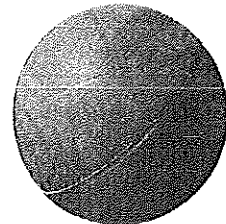
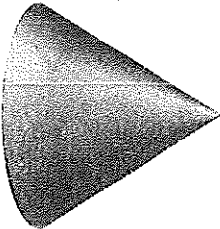

8

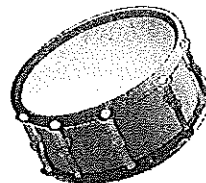
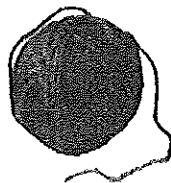
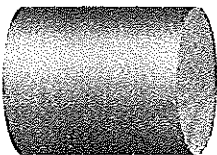

Copyright © The McGraw-Hill Companies, Inc. (1 to 4) Stock/Photo/Photo; (2, 3) Mark Steinmetz/The McGraw-Hill Companies, Inc.; (4) Mark Steinmetz; (5, 6, 7, 8) Mark Steinmetz/The McGraw-Hill Companies, Inc.; (9) Royalty-Free/CORBIS; (10) Ken Cavatagli/The McGraw-Hill Companies; (11) Mark Steinmetz/The McGraw-Hill Companies, Inc.



Directions: 5–8. Name the first shape in the row. Describe it. Compare it to the shapes of the objects in the row. Circle the matching shape.



Problem Solving



Mathematical
PRACTICE

9

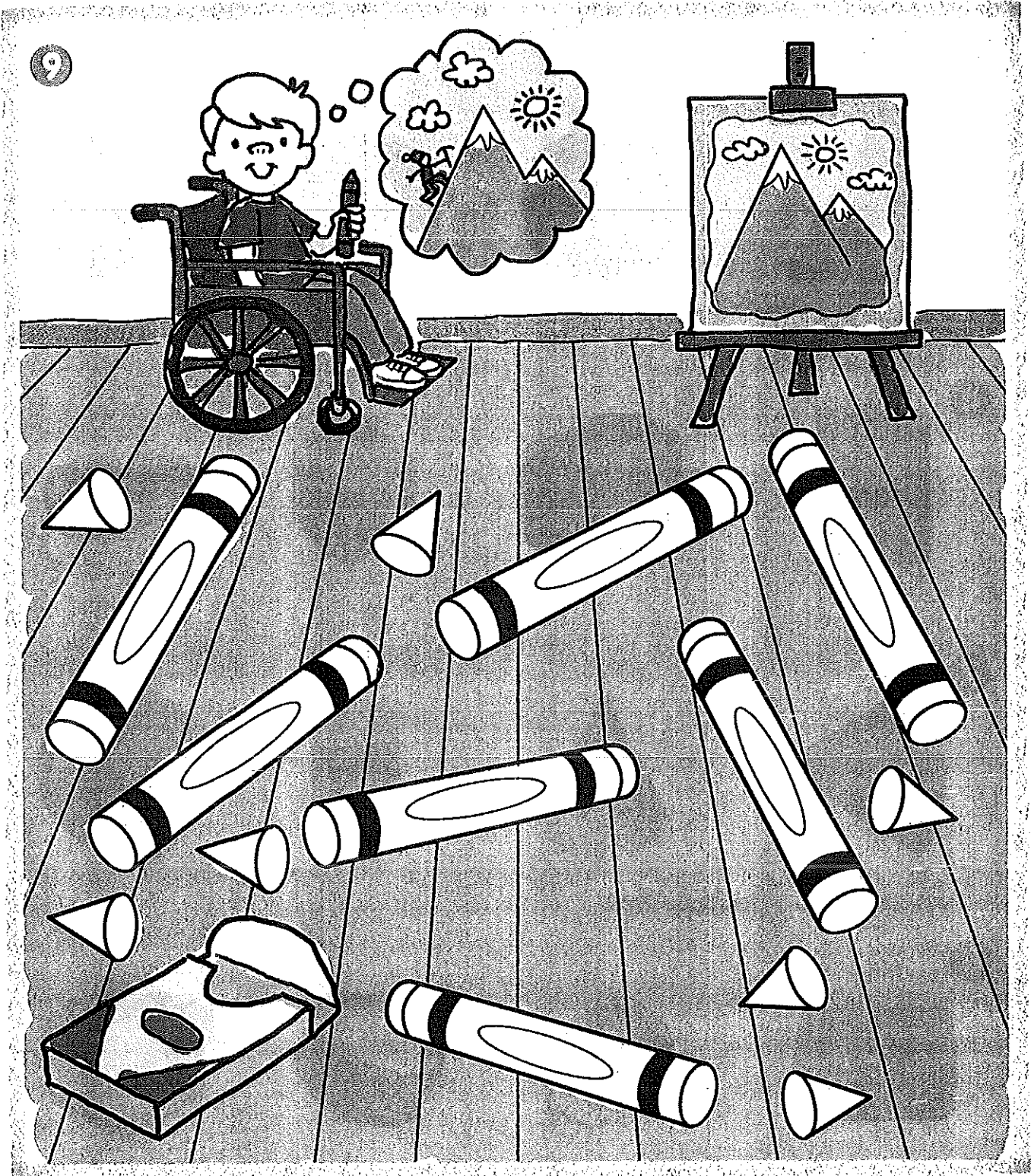

Directions: 9. Point to the broken pieces of crayons. Name the shape of each piece. Identify each shape by coloring the cones blue and the cylinders red.

Name

My Homework

Lesson 2

Cylinders and Cones

Homework Helper



Need help? connectED.mcgraw-hill.com

1

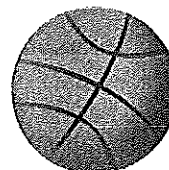
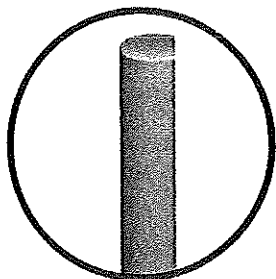
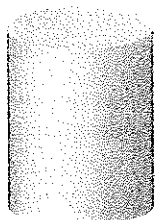

2

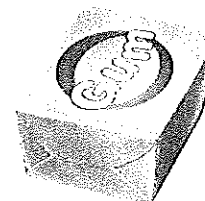
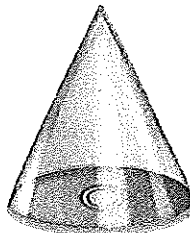
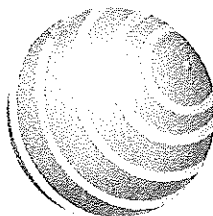
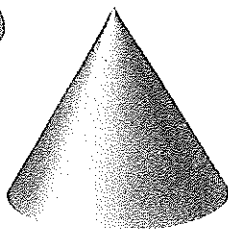

3

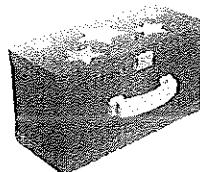
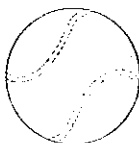
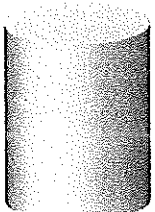

4

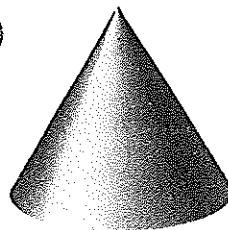

Directions: 1–4. Name the first shape in the row. Describe it. Compare it to the shapes of the objects in the row. Circle the matching shape.

5

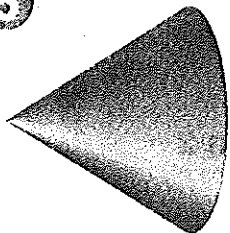

6

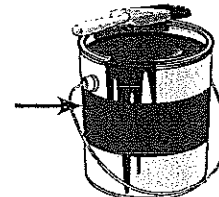
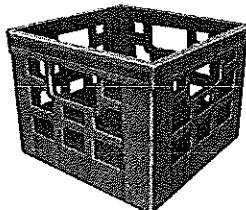
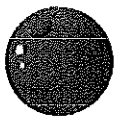
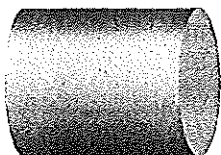

Vocabulary Check



7

cylinder

8

cone



Directions: 5–6. Name the first shape in the row. Describe it. Compare it to the shapes of the objects in the row. Circle the matching shape. 7. Draw an object that is shaped like a cylinder. Tell what you drew. 8. Draw an object that is shaped like a cone. Tell what you drew.

Math at Home Have your child find objects in your home shaped like cylinders and cones.

Directions: Write a sentence. Remember to write a capital letter at the beginning and leave space between your words. Draw a picture to go with your sentence.

The page contains five sets of handwriting practice lines. Each set consists of three horizontal lines: a solid top line, a dashed middle line, and a solid bottom line. These lines are spaced evenly down the page to provide a guide for letter height and placement.

WEEKLY ACTIVITY SHEET

Week #31 Please return to school on Wednesday April

Sight Word(s) of the Week

Read, trace and write the sight word(s).

Math Zone

good good _____	18 is _____ ten and _____ more.
good good _____	12 is _____ ten and _____ more.
who who _____	14 is _____ ten and _____ more.
who who _____	16 is _____ ten and _____ more.
Who is a good reader?	20 is _____ ten and _____ more.

Wonders Unit 10 Week 1

RCD Math Unit 7 (Wk 4:4)

Reading Log

Please read with your child at least 1 book a day, every day. Record the title of the book on the line.

Wed:
Thurs:
Fri:
Sat:
Sun:
Mon:
Tue:

Write the word on the line

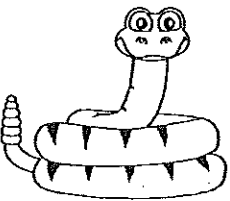
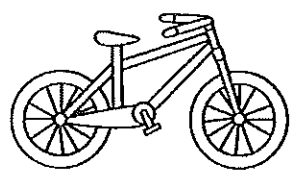
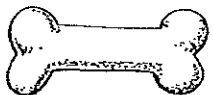
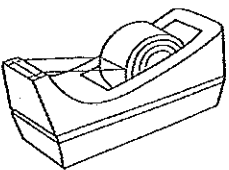
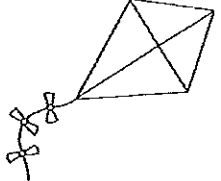
				
_____	_____	_____	_____	_____
_____	_____	_____	_____	_____
_____	_____	_____	_____	_____

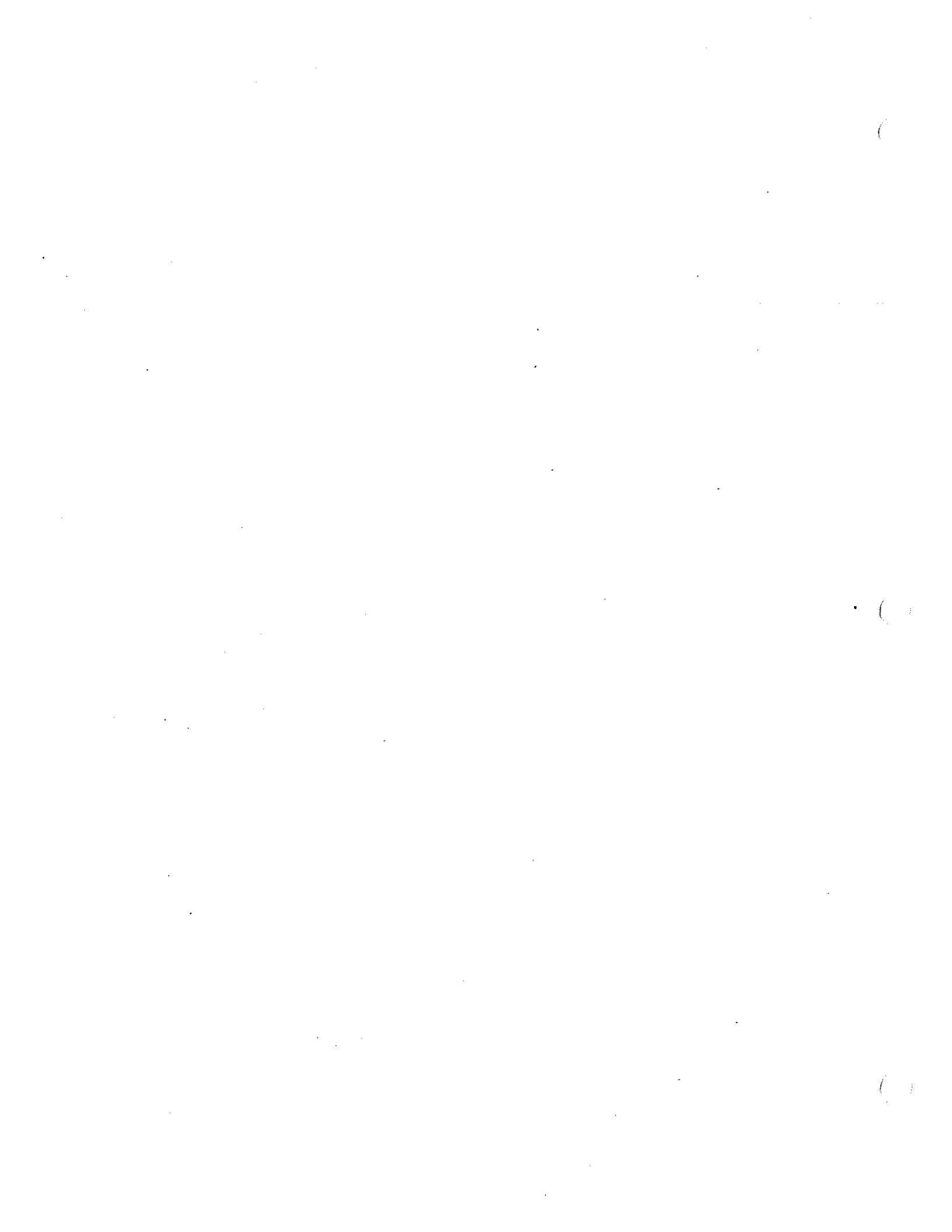

Please have your child practice writing their first and last name correctly on the lines below.

Please practice these skills with your child *daily*.

- high frequency words (reading and writing)
- Writing words by sounding them out
- counting to 100 by 1's and 10's
- Writing and recognizing the numbers 0-20
- Adding and subtracting numbers up to 10
- recognizing 3D shapes (cone, cube, cylinder and sphere)

On the lines below, have your child write at least 1 sentence. Let them sound out the words and write down the sounds they hear even if they spell them incorrectly. You may help them sound out words, but please do not tell them how to spell a word. Remind them to start their sentence with a capital letter, leave space between their words and put a punctuation mark at the end of their sentence. Have them draw a picture to go with their sentence. Have them read to you what they wrote.

()

()

()

Name _____

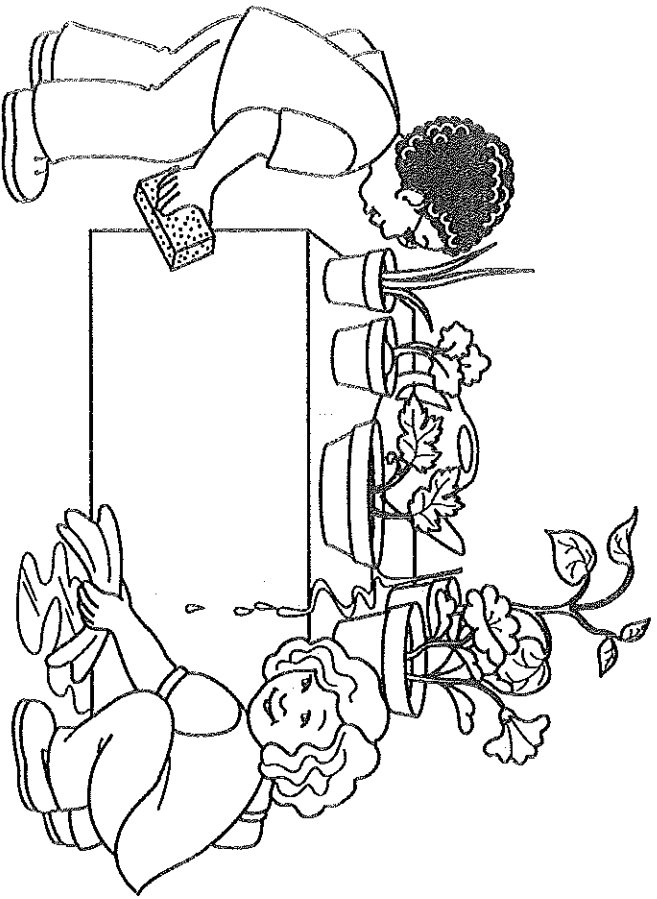

Sam is good at this.

He can help mop.

Copyright © McGraw-Hill Education

High Frequency Words: *who, good*
Read the book aloud to a partner. Reread for fluency.

Who Can Help?

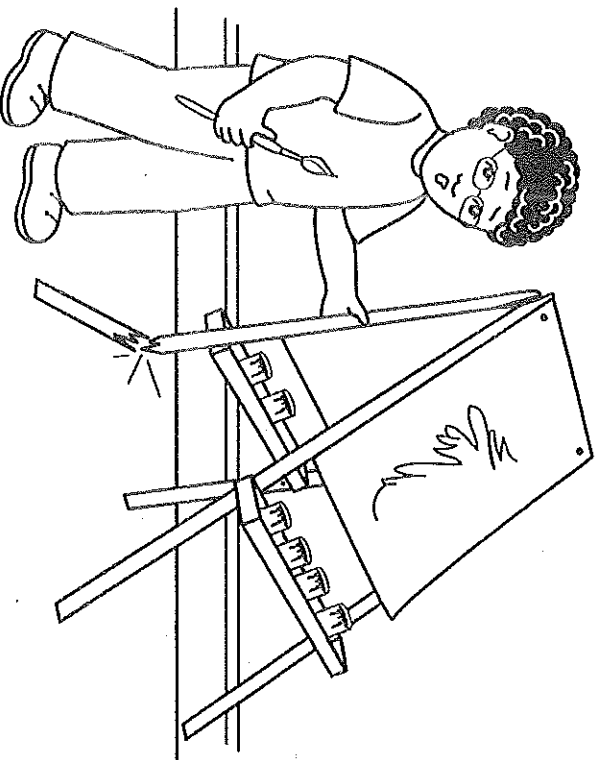

This is not good!

Who can I get to help?

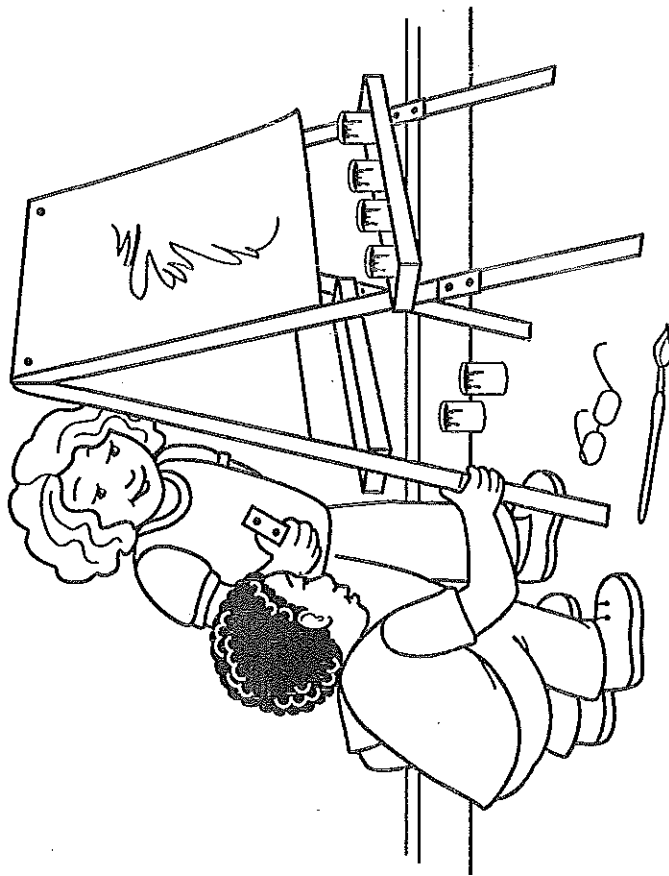



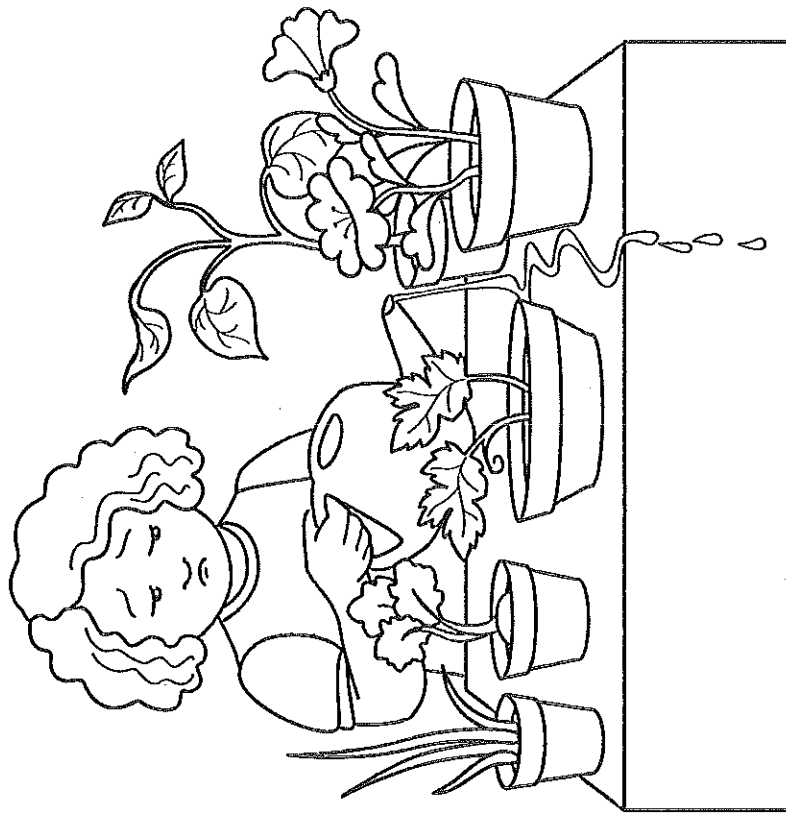









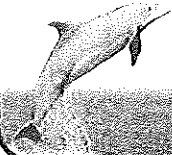







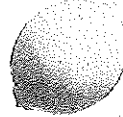

Deb can help me fix it.
She is good at this.

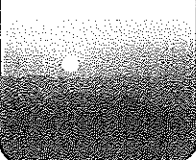

This is not good.
Who can help mop?

Name _____

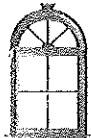
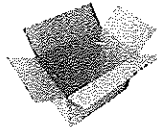
The Alphabet

Aa 	Bb 	Cc 	Dd 	Ee 	Ff 
Gg 	Hh 	Ii 	Jj 	Kk 	Ll 
Mm 	Nn 	Oo 	Pp 	Qq 	Rr 
Ss 	Tt 	Uu 	Vv 	Ww 	Xx 
Yy 	Zz 				

Handwriting Models

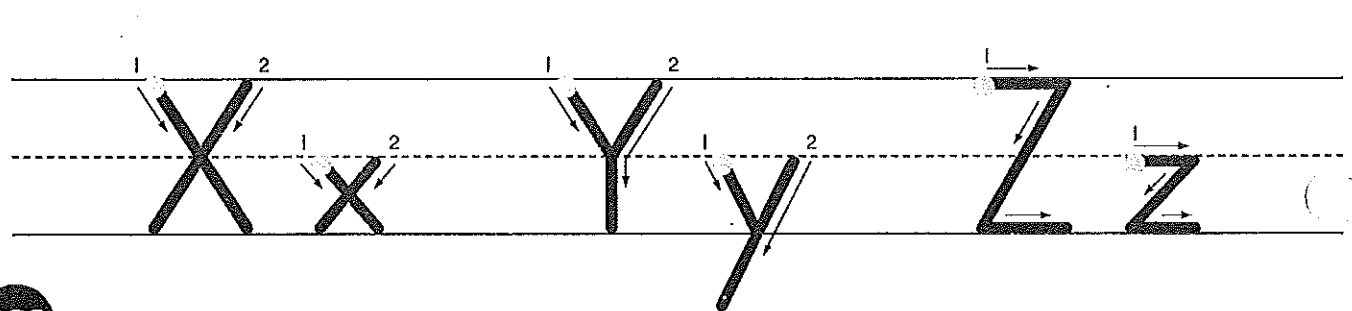
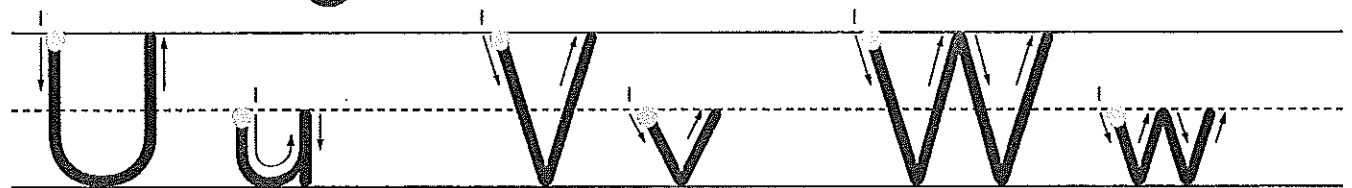
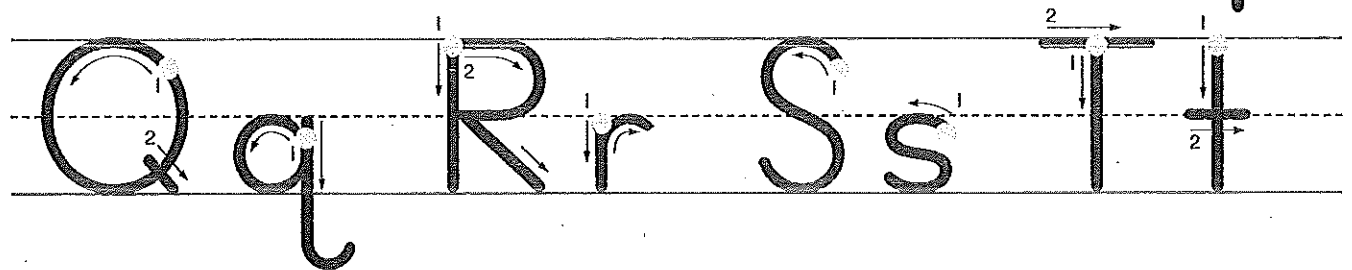
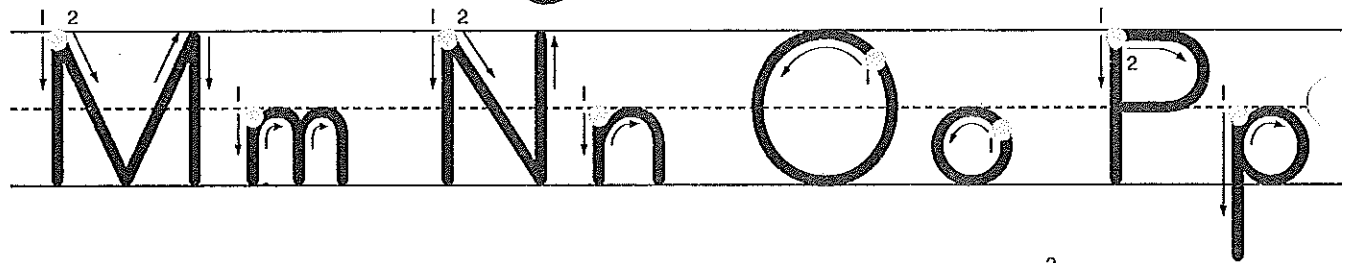
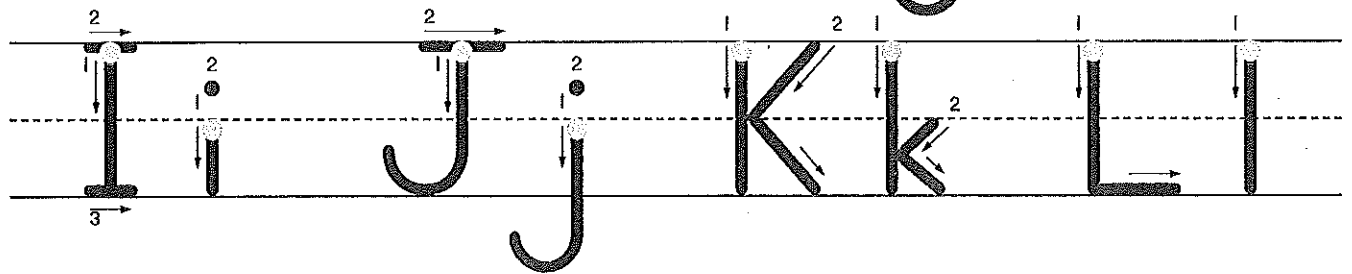
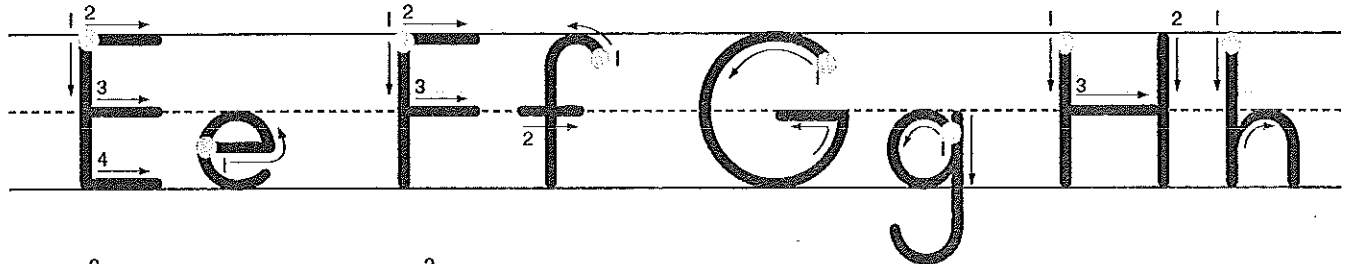
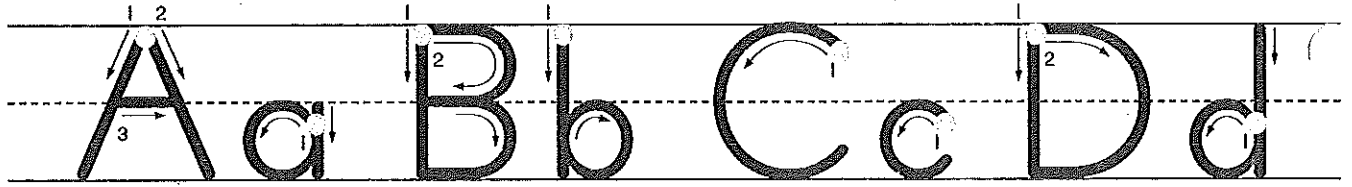

Name _____

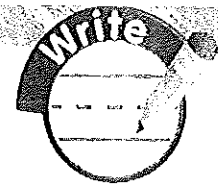
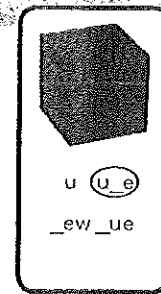

1.

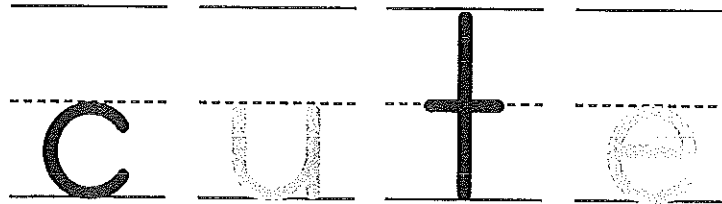

2.

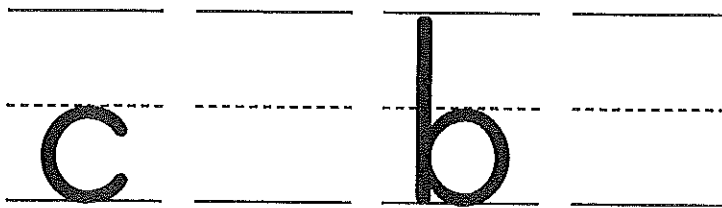
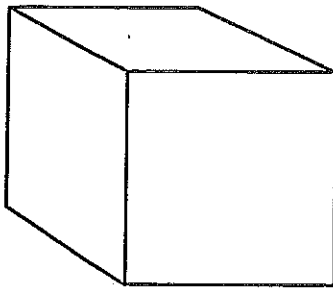

3.

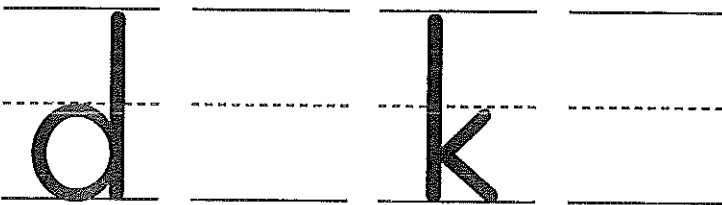
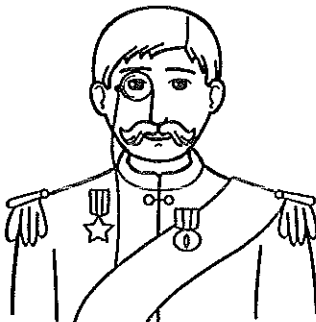

4.

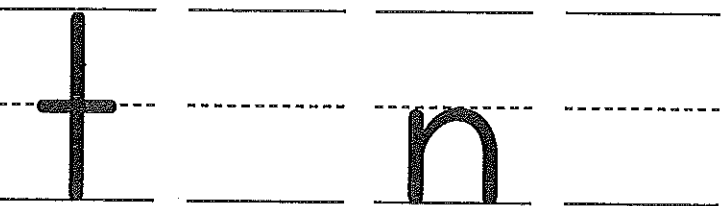

Phonics: /ū/u_e

Write the letters that stand for long *u* in each picture name.



Name _____

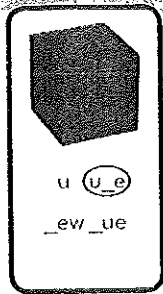

JUNE						
S	M	T	W	T	F	S
		1	2	3	4	5
6	7	8	9	10	11	12
13	14	15	16	17	18	19
20	21	22	23	24	25	26
27	28	29	30			

1. It is June.

2. _____



3. Play a tune!

4. _____

Copyright © McGraw-Hill Education

Handwriting: Sentences with /ū/u_e
Say each word as you trace it and write it. Then read each sentence to a partner.

Match and write it.

sat

nap

wag

~~bag~~

mat

Pam

gas

tag



bag

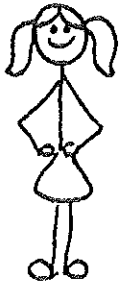

()

()

()

Match and write it.

pig

win

wig

~~lip~~

mitt

fin

sit

pin



lip



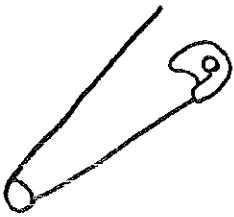

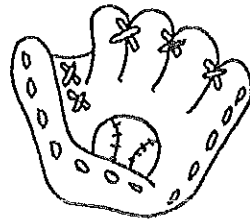



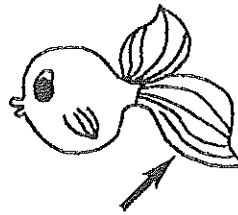





()

()

()

Name _____

Compare Solid Shapes

Lesson 3

ESSENTIAL QUESTION
How do I identify and compare three-dimensional shapes?





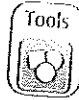

Explore and Explain

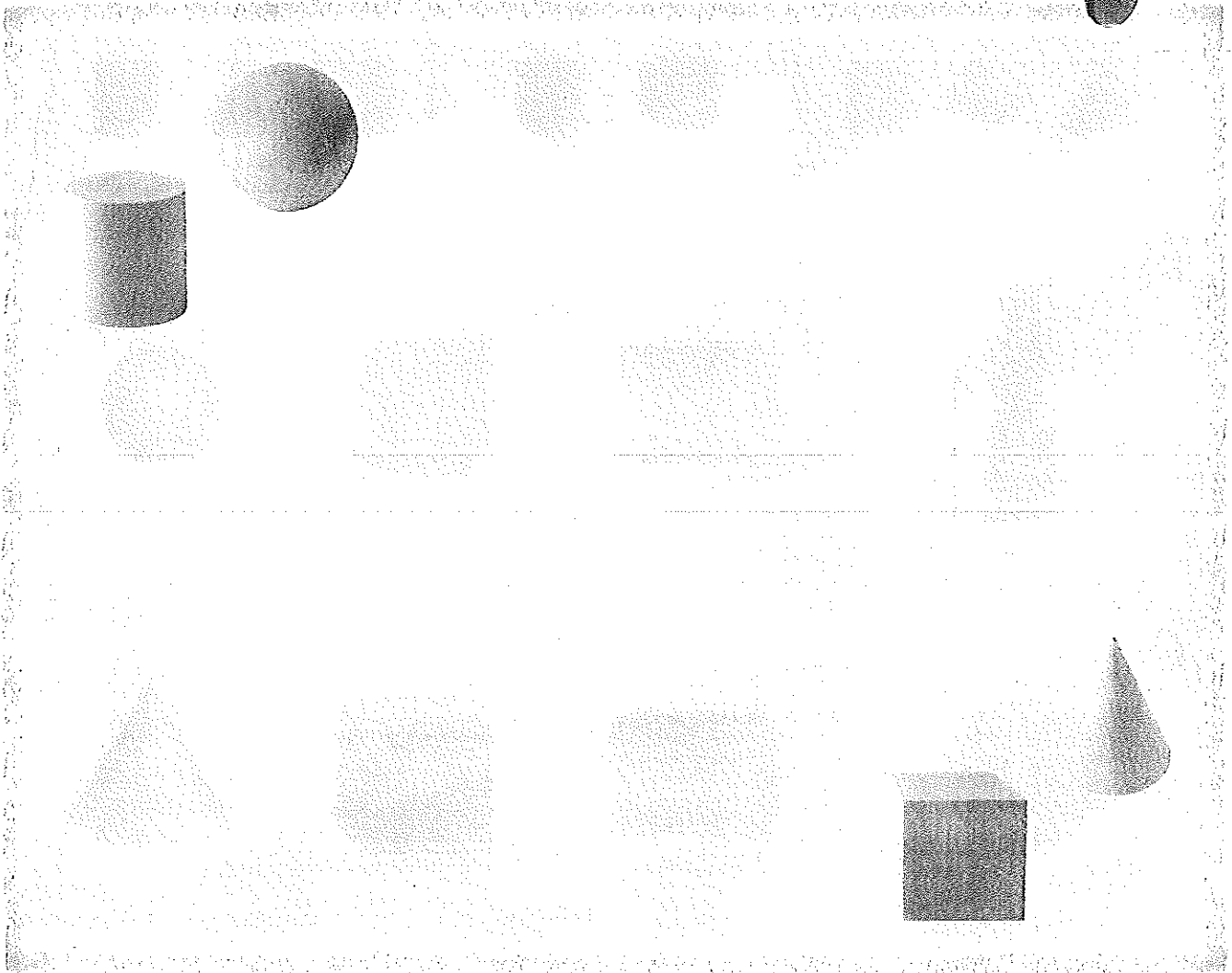
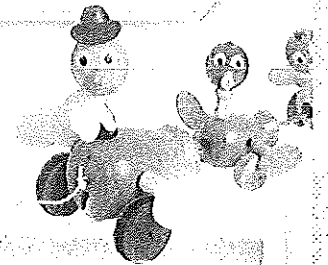

Let's roll!



Teacher Directions: Use , , , and  to identify and compare solid shapes. Show which shapes roll, slide, and can have another shape stacked on it. Name an object in the classroom that rolls, slides, or stacks the same as one of the solid shapes. Draw the object. Tell how you know.



See and Show

1 roll

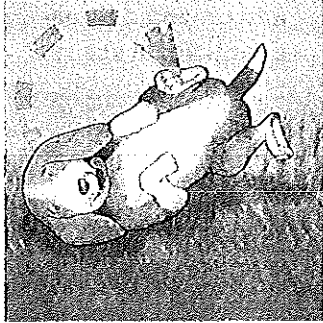

2 stack



3 slide



4

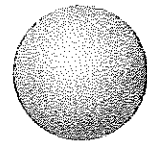
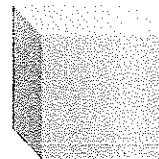
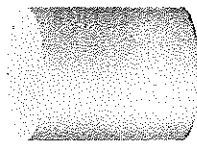

5

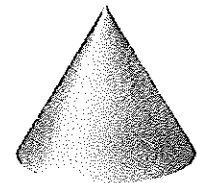
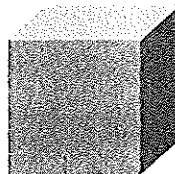
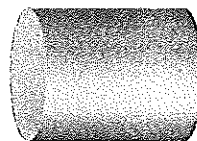
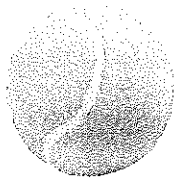

Directions: 1–3. Trace the arrows to show roll, stack, and slide. Name the shapes shown that roll, stack, and slide. 4. Identify the shape of the first objects in the row. Describe it. Circle the other shape(s) in the row that stack in the same way. 5. Identify the shape of the first object in the row. Describe it. Circle the other shape(s) in the row that roll.

Name _____

I slide,
too!



On My Own

6

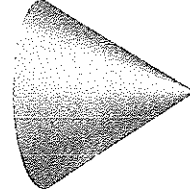
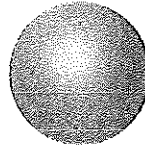
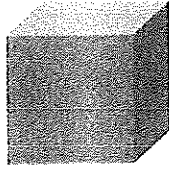
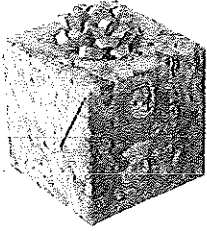

7

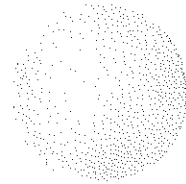
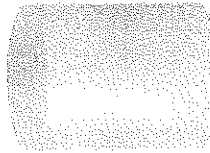
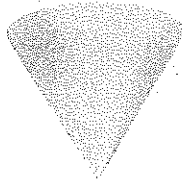
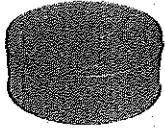

8

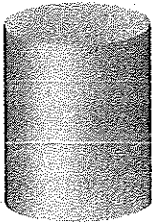

9

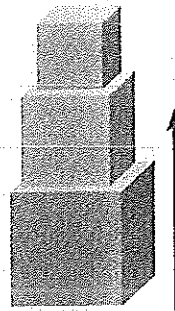

Directions: 6. Identify the shape of the first object in the row. Describe it. Circle the other shape(s) in the row that slide. 7. Identify the shape of the first object in the row. Describe it. Circle the other shape(s) in the row that roll. 8. Draw an object that would roll as a cylinder. 9. Draw an object that would stack as the cubes are stacked.



10

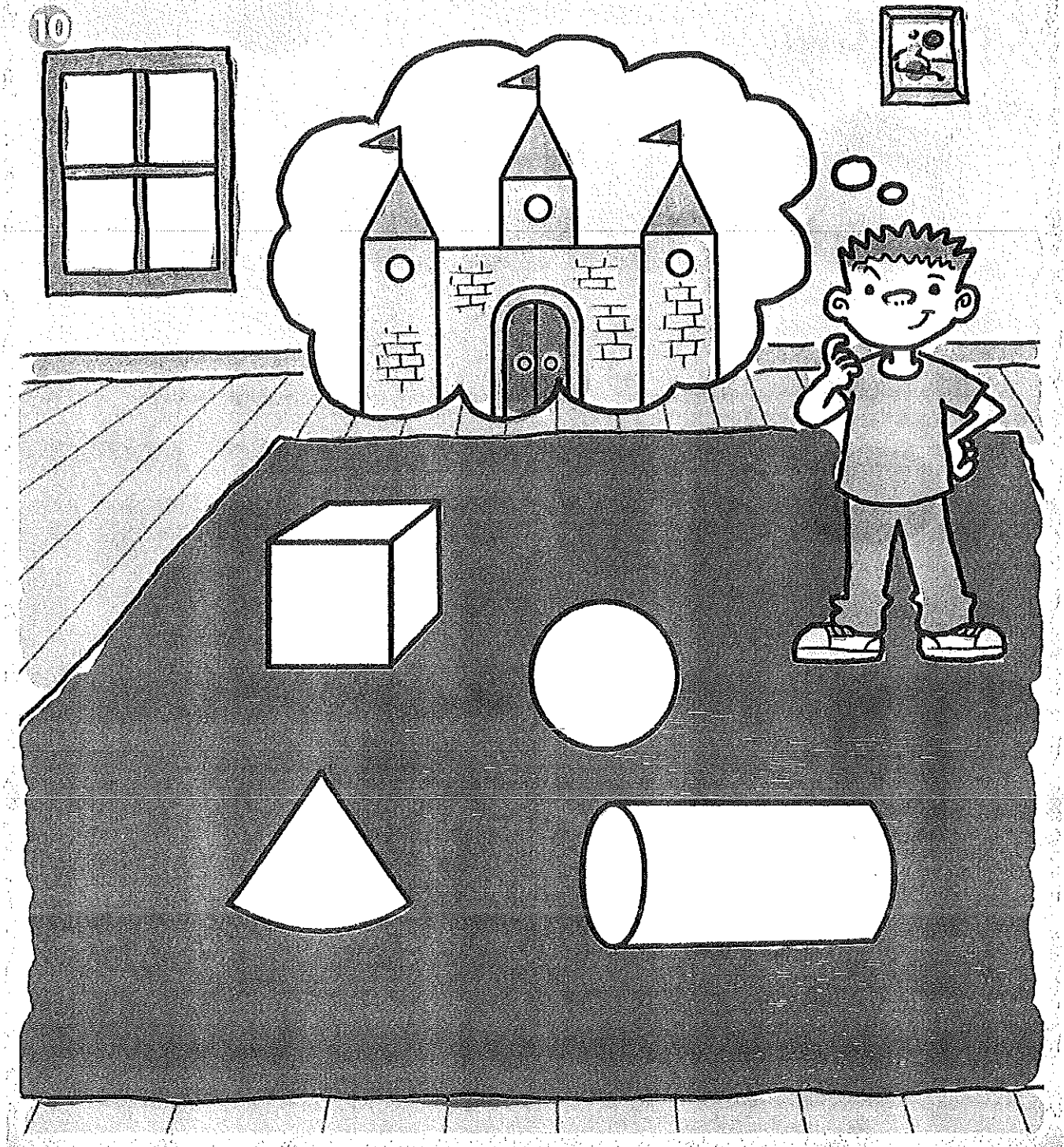

Directions: 10. Look at the shapes on the carpet. Find a shape that rolls, stacks, and slides. Color it orange. Find a shape that only slides and rolls and cannot have a shape stacked on it. Color it purple. Find a shape that only slides and stacks. Color it yellow. Find a shape that only rolls. Color it blue.

Name

My Homework

Lesson 3

Compare Solid Shapes

Homework Helper



Need help? connectED.mcgraw-hill.com

1

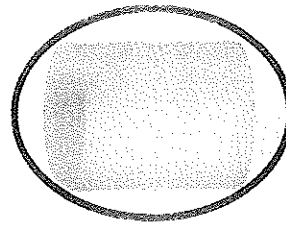
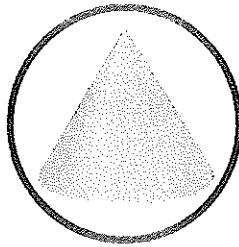

2

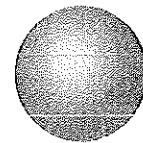
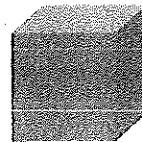
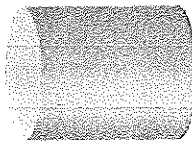

3

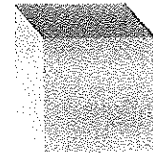
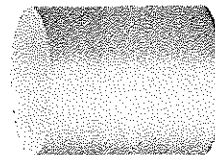
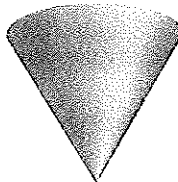
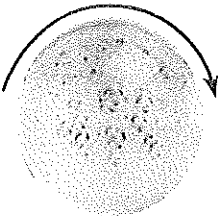

Directions: 1. Identify the shape of the first object in the row. Describe it. Circle the other shape(s) in the row that slide. 2. Identify the shape of the first objects in the row. Describe it. Circle the other shape(s) in the row that stack in the same way. 3. Identify the shape of the first object in the row. Describe it. Circle the other shape(s) in the row that roll.

4

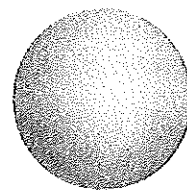
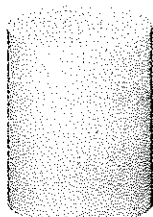
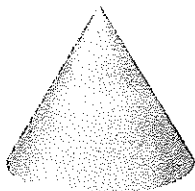
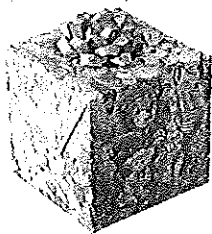

Vocabulary Check



5

roll

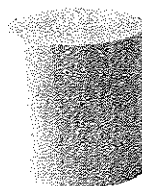
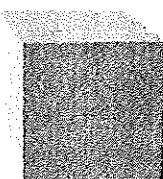
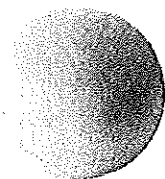

6

stack

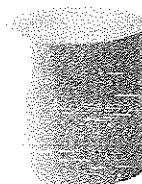
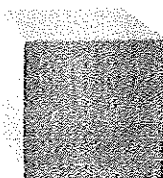
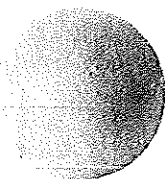

7

slide

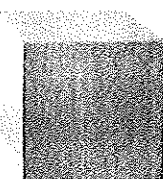
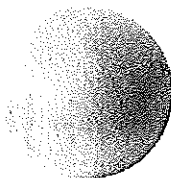

Directions: 4. Identify the shape of the first shape in the row. Describe it. Circle the other shape(s) in the row that slide. 5. Identify the shapes. Circle the shapes that roll. 6. Identify the shapes. Circle the shapes that can have another shape stacked on it. 7. Identify the shapes. Circle the shapes that slide.

Math at Home Have your child name the solid shapes on the My Homework pages that roll, stack, and slide. Have your child imitate these movements.

Name _____

Check My Progress

Vocabulary Check



1 sphere

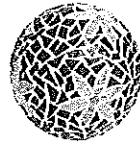
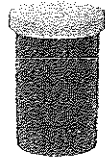

2 cylinder

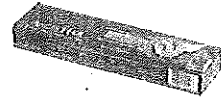

Concept Check

3

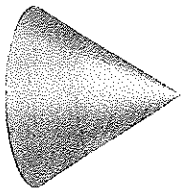

Directions: 1. Draw an X on the objects that are not shaped like a sphere. 2. Draw an X on the objects that are not shaped like a cylinder. 3. Name the first shape in the row. Compare it to the shapes of the objects in the row. Circle the matching shape.

4

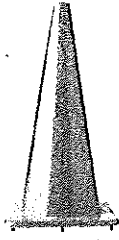
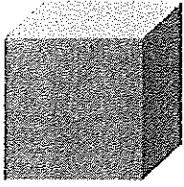

5

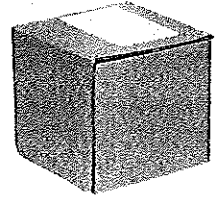
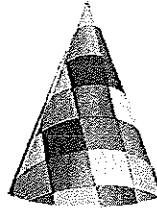
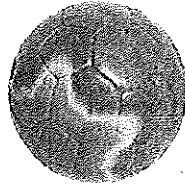

6

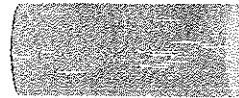
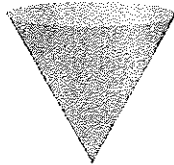
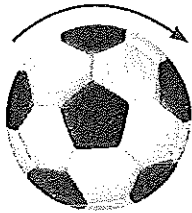

7

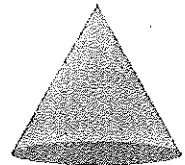
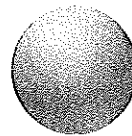
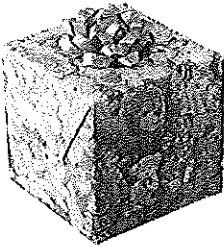

Directions: 4. Name the first shape in the row. Compare it to the shapes of the objects in the row. Circle the matching shape. 5. Identify the first objects in the row. Describe them. Circle the other shape(s) in the row that stack in the same way. 6. Identify the first object in the row. Describe it. Circle the other shape(s) in the row that roll. 7. Identify the first object in the row. Describe it. Circle the other shape(s) in the row that slide.

Directions: Write a sentence. Remember to write a capital letter at the beginning and leave space between your words. Draw a picture to go with your sentence.

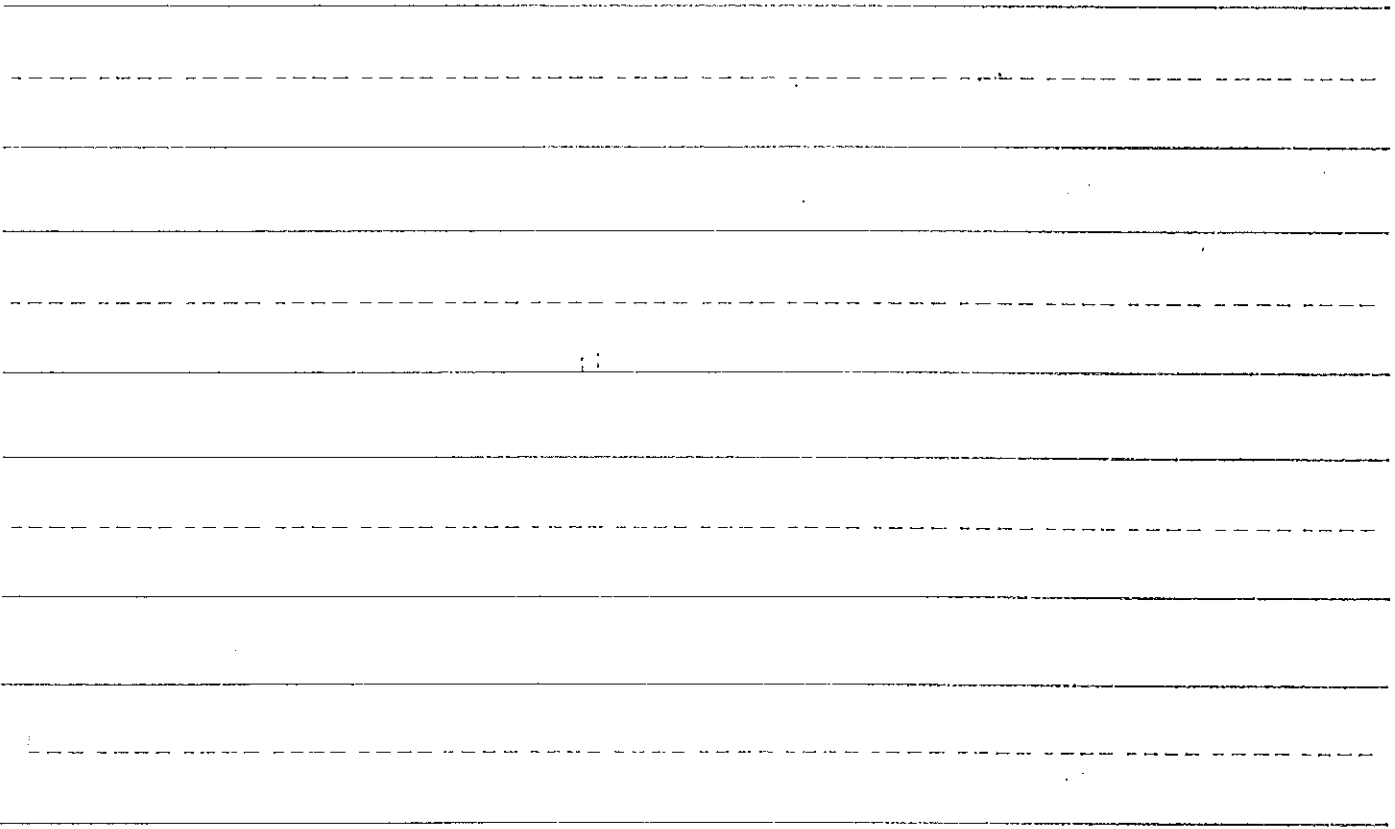

The page contains five sets of handwriting practice lines. Each set consists of three horizontal lines: a solid top line, a dashed middle line, and a solid bottom line. These lines are spaced evenly down the page to provide a guide for letter height and placement.

(

(

(

WEEKLY ACTIVITY SHEET

Week #32 Please return to school on Wednesday April

Sight Word(s) of the Week

Read, trace and write the sight word(s).

Math Zone

Practice naming these 3-D shapes. Find them around the house.

come	come	_____
come	come	_____
does	does	_____
does	does	_____
Does the hat come in red?		

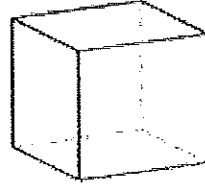

cube

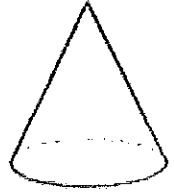

cone

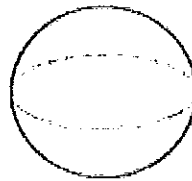

sphere

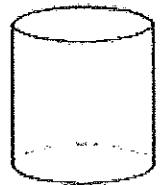

cylinder

Wonders Unit 10 Week 2

RCD Math Unit 8 (Wk 1:4)

Reading Log

Please read with your child at least 1 book a day, every day. Record the title of the book on the line.

Wed:

Thurs:

Fri:

Sat:

Sun:

Mon:

Tue:

Write the word on the line

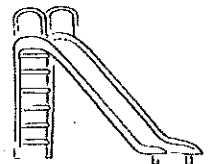
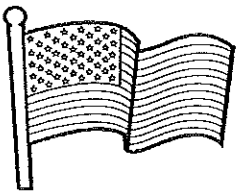

_____	_____	_____	_____	_____
_____	_____	_____	_____	_____
_____	_____	_____	_____	_____



Please have your child practice writing their first and last name correctly on the lines below.

Please practice these skills with your child *daily*.

- high frequency words (reading and writing)
- Writing words by sounding them out
- counting to 100 by 1's and 10's
- Writing and recognizing the numbers 0-20
- Adding and subtracting numbers up to 10
- recognizing 3D shapes (cone, cube, cylinder and sphere)

On the lines below, have your child write at least 1 sentence. Let them sound out the words and write down the sounds they hear even if they spell them incorrectly. You may help them sound out words, but please do not tell them how to spell a word. Remind them to start their sentence with a capital letter, leave space between their words and put a punctuation mark at the end of their sentence. Have them draw a picture to go with their sentence. Have them read to you what they wrote.

Blank handwriting lines for writing a sentence and drawing a picture.

Name _____

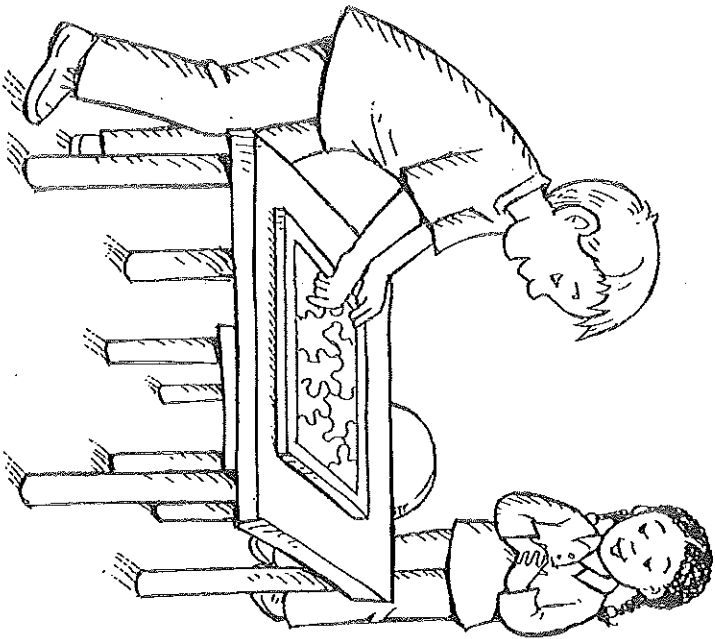

If does fit in here!

Come and see!

Copyright © McGraw-Hill Education

Come and See

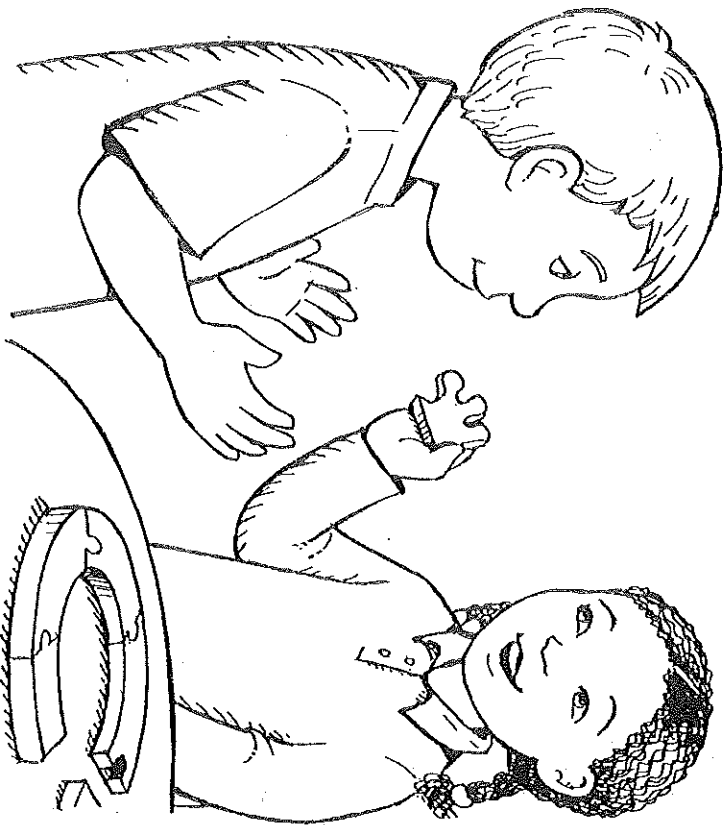

Can you help me?

Where does it go?

High Frequency Words: *come, does*
Read the book aloud to a partner. Reread for fluency.

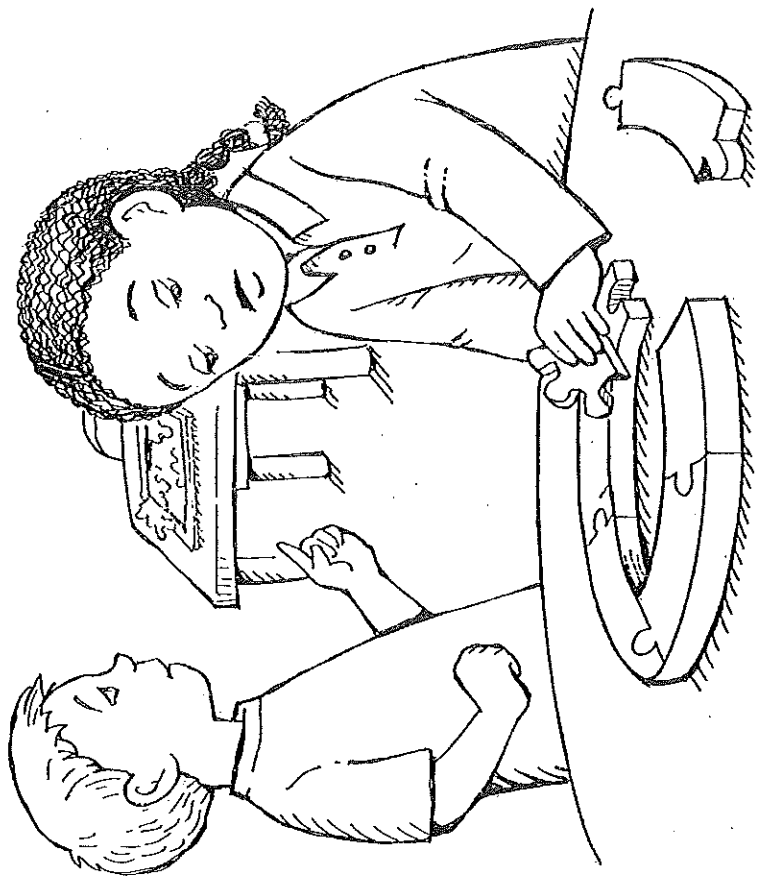

Copyright © McGraw-Hill Education

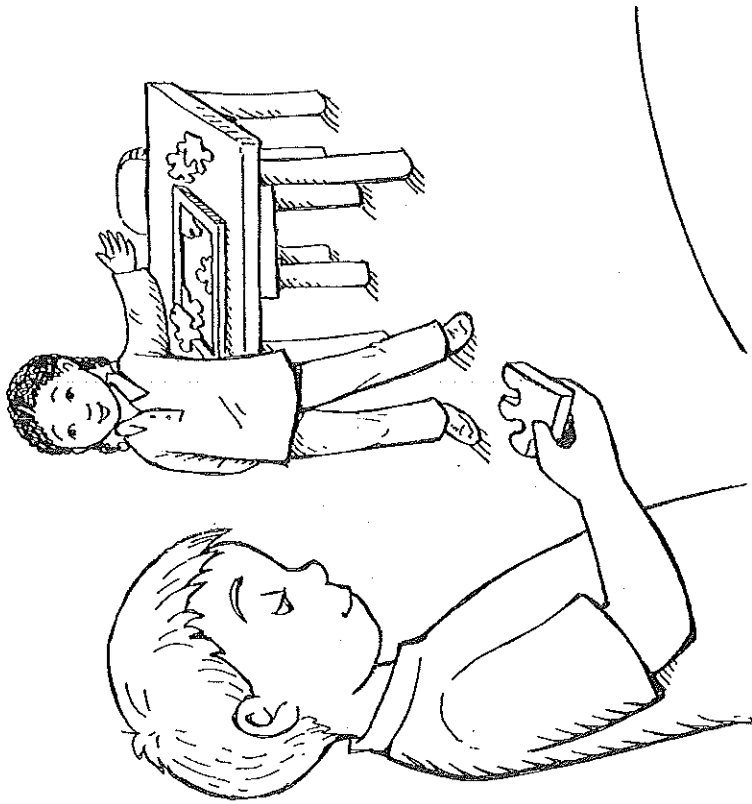

Does it fit here?











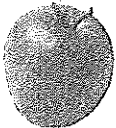



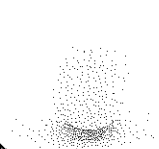

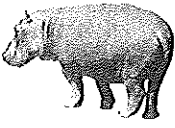



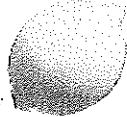

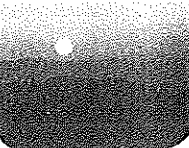

No, it does not fit.

Come and see this!

Does it go in here?

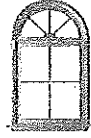
Name _____

The Alphabet

Aa 	Bb 	Cc 	Dd 	Ee 	Ff 
Gg 	Hh 	Ii 	Jj 	Kk 	Ll 
Mm 	Nn 	Oo 	Pp 	Qq 	Rr 
Ss 	Tt 	Uu 	Vv 	Ww 	Xx 
Yy 	Zz 				

Handwriting Models

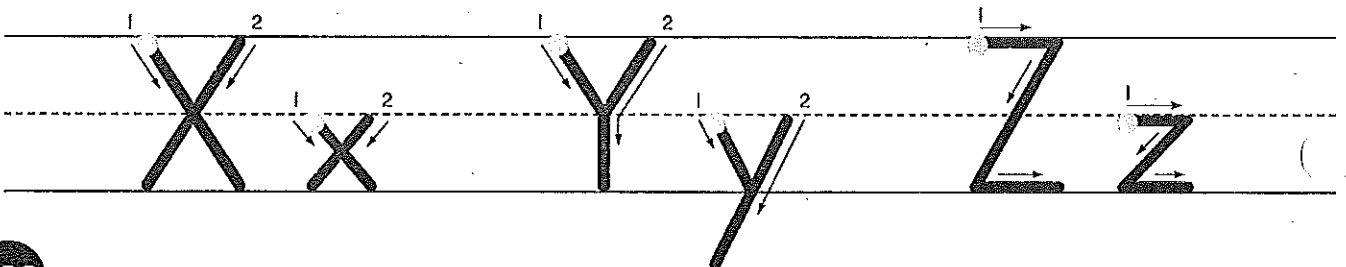
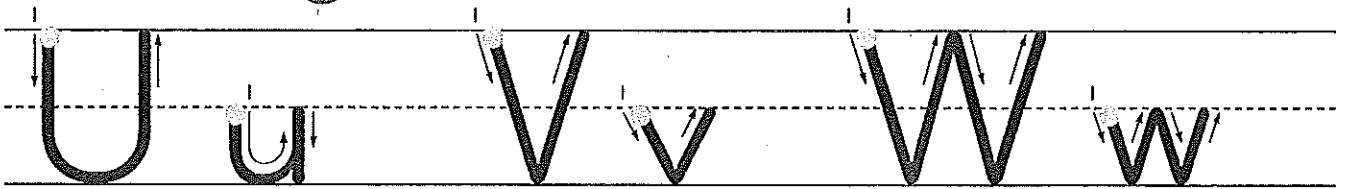
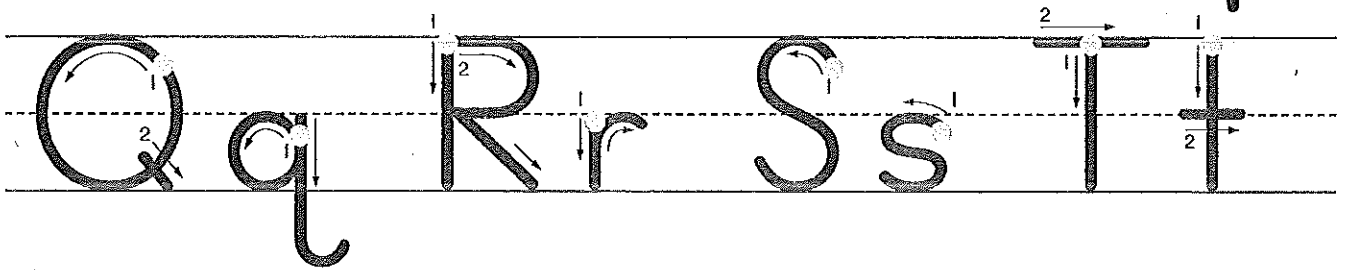
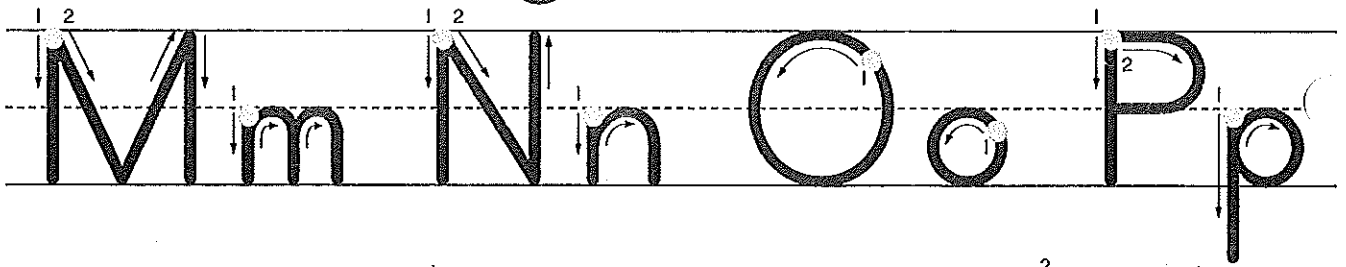
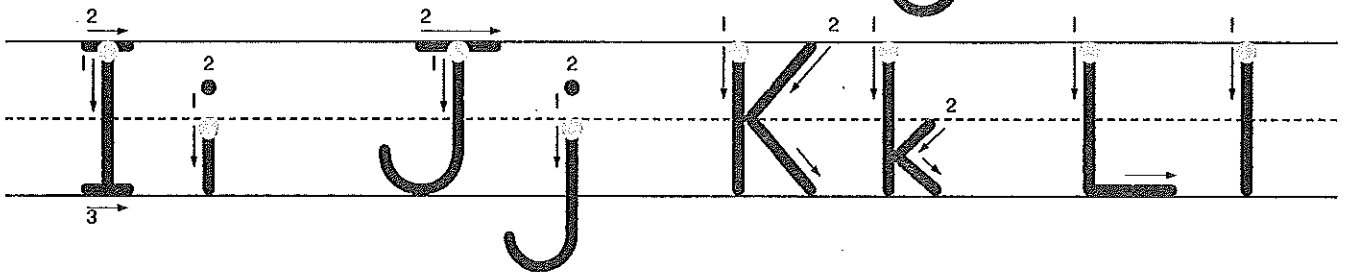
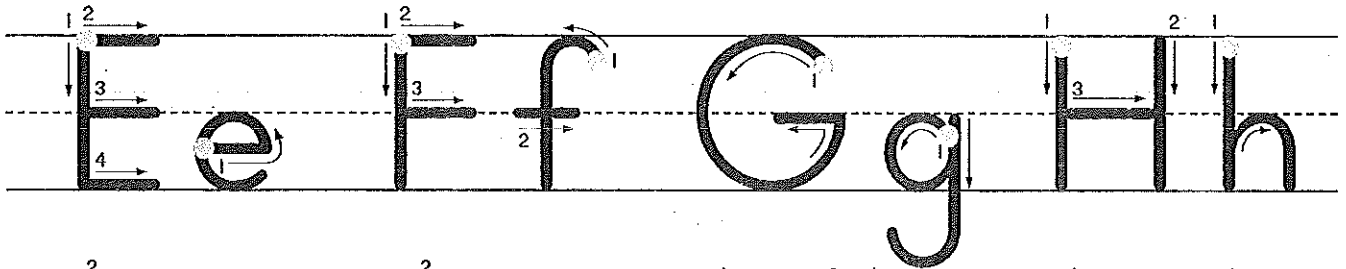
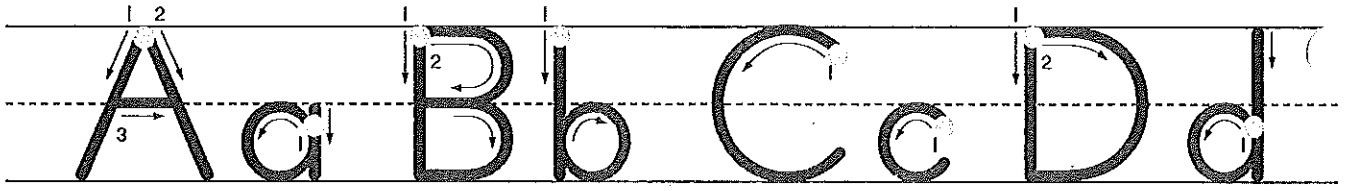

Name _____

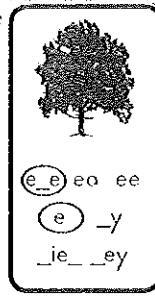

1.

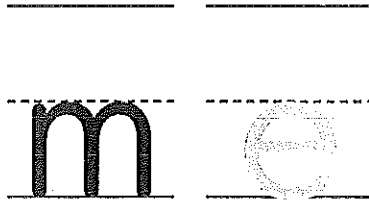
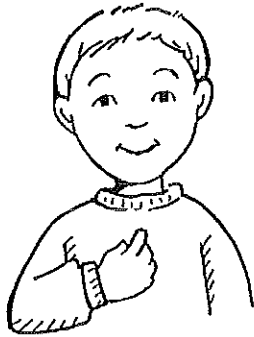

2.

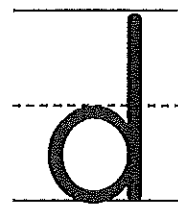
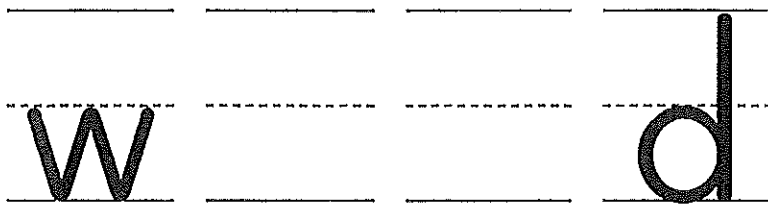
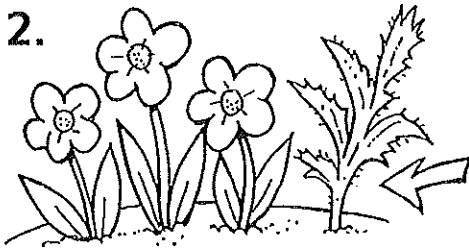

3.

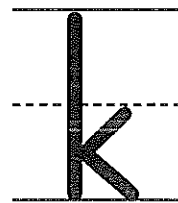
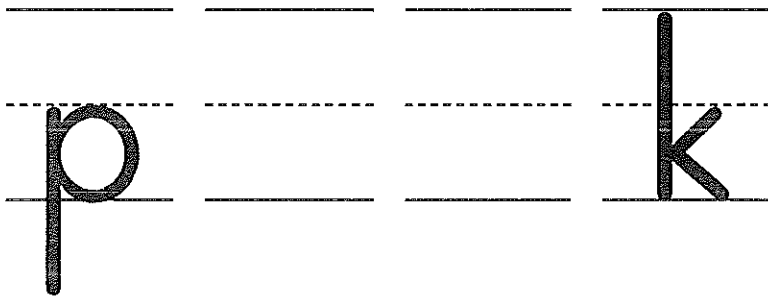
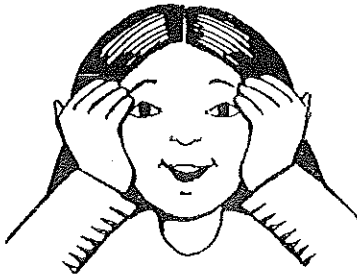

4.

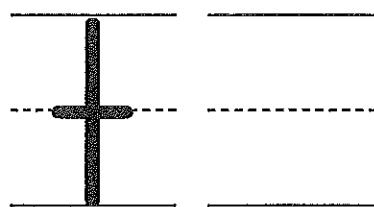
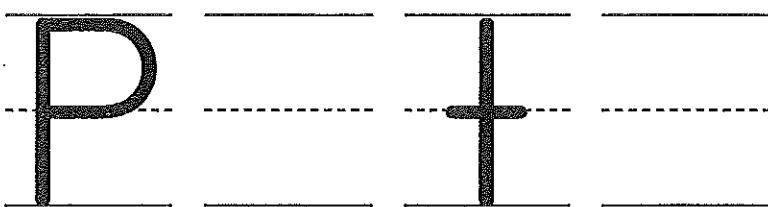

Phonics: /ē/e_e, ee, e
Write the name of each picture. Then write the letters that stand for long e in each picture name.



Name _____

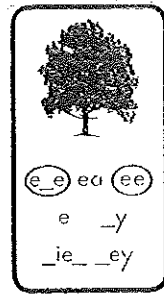

1. I see a bee.

2. _____



3. I see Eve.

4. _____

Copyright © McGraw-Hill Education

Handwriting: Sentences with /ē/e_e, ee
Say each word as you trace it and write it. Then read each sentence to a partner.

Match and write it.

rug

~~hug~~

sun

gum

bus

bug

run

cup



hug

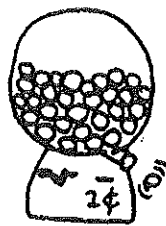

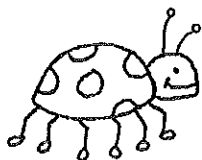

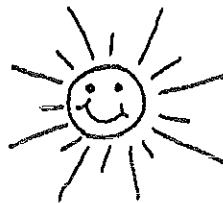

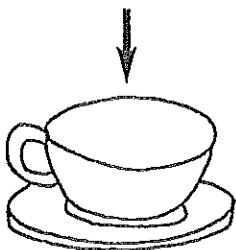

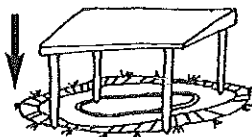





()

()

()

Match and write it.

six

fill

cut

Dan

mix

duck

~~nut~~

fix

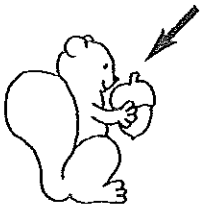

nut



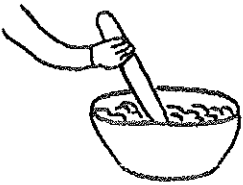

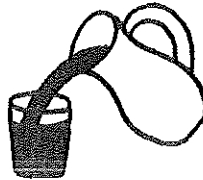

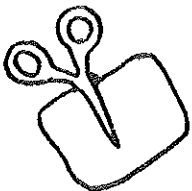

6



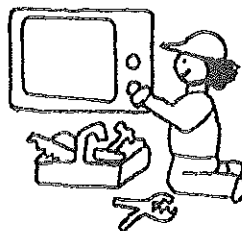

(

(

(