

2019

Summer Math Packet

The Wyndcroft School

This packet is for students entering 7th grade in the fall.

This packet will be collected during the first week of school next year.

Please write answers on packet and attach all math work.

Name: _____

Section 1: Decimal Operations:

*Directions: Evaluate the expressions. ***For expressions with division: Round to nearest hundredth if needed.*

1). $373.8 + 3.29 + 165.23$	2). $2041.56 - 202.8$	3). 87.86×1.04	4). $105.6 \div 5.5$
5). $68.7 + 1.47$	6). $216.52 - 97.921$	7). 9.1×5.3	8). $44.2 \div 0.68$

Section 2: Order of Operations:

Directions: Evaluate the expression.

1). $18 + 1(12) \div 6$	2). $4^3 \div (16 - 12) \times 3$	3). $5^2 - 4 \times 6 \div 3$
4). $\frac{36}{3^2 - 3}$	5). $4 - 3 + 7(12 - 2^2)$	6). $\frac{8 + 2(4 - 1)}{3^2 - 2}$

Section 3: Algebraic Expressions:

Directions: Evaluate each expression if $w=2$, $x=6$, $y=4$, and $z=5$.

1). $3z - 2w$	2). $\frac{wz^2}{y + 6}$	3). $2(xy - 9) \div z$
------------------	-----------------------------	---------------------------

Section 4: Integers:

Directions: Evaluate the following expressions. Note "(parenthesis)" used to help denote negatives.

1). $-47 - 26$	2). $41 + (-19)$	3). $96 \div (-4)$
4). $\frac{-117}{13}$	5). $18.037 + (-27.3) + 12.471$	6). $(-17)(-3)$
7). $-71 - (-35)$	8). $(-5)(3)(-8)$	9). $\frac{-48}{-16}$
10). $(-58 + 45)(-2^2)$	11). $\frac{97 - 125}{-7}$	12). $(65 \div 5) + (-12) \times 2$
13). $\frac{ -66 + (-46) }{-7}$	14). $[-8 \div (-4) - 4] \times (-25)$	15). $(-2^3)(-3^2)$

Section 5: Writing Expressions and Equations:

Directions: Write each verbal phrase as an expression or equation.

- 1). Six divided by a number is twenty-seven: _____
- 2). Negative nine times the quantity of fifty-five less than a number: _____
- 3). Ten plus a number divided by negative six is sixteen: _____

Section 6: Equations:

Directions: Solve the equations. Note some "(parenthesis)" used to help denote negatives.

1). $z - 90 = (-35)$	2). $\frac{x}{-8} = (-8.5)$
3). $-6 = 49 - j$	4). $17 + k + (-8) = (-2)$
5). $\frac{y}{-4} = (-45 + -15)$	6). $-93 = (-3d)$

Section 7: Algebraic Expressions:

Directions: Evaluate the following expressions.

$h = -4 \quad y = 1 \quad a = 3 \quad s = -2$	
1). $(h + a)y - s^3$	2). $\frac{(s + h)}{(y - a)}$
3). $(s - y)a + h(a - s)$	4). $s(h + y)^2$

Section 8: Fraction Operations:

Directions: Evaluate each expression. Write each mixed number or fraction in simplest form.

1). $\frac{4}{15} \times \frac{5}{12}$	2). $-\frac{1}{3} - \frac{1}{6}$	3). $\frac{3}{4} + -9$
4). $\frac{5}{8} + \frac{1}{6}$	5). $-\frac{3}{4} \times \frac{4}{5}$	6). $\frac{4}{15} + \frac{13}{15}$
7). $\frac{7}{8} \times \frac{1}{3}$	8). $\frac{3}{5} - \frac{2}{3}$	9). $3\frac{1}{3} \div -4$
10). $4\frac{1}{4} + 6\frac{3}{4}$	11). $-3\frac{2}{3} \times -3\frac{1}{2}$	12). $-8\frac{1}{2} + 1\frac{2}{3}$
13). $\frac{10}{21} \times -\frac{7}{8}$	14). $1\frac{1}{4} - \frac{5}{6}$	15). $\frac{5}{9} \div \frac{20}{27}$

Section 9: Equations with Rational Numbers:

Directions: Solve the equation.

1). $-10.5 = \frac{b}{-7.5}$	2). $q - \frac{1}{5} = \frac{2}{3}$
3). $3.5z = -\frac{7}{8}$	4). $-5\frac{3}{4} = -2\frac{1}{2}g$
5). $n - 0.64 = -5.44$	6). $\frac{k}{1.2} = -6$

Section 10: Square Roots:

Directions: Find each square root.

1). $\sqrt{4900}$	2). $-\sqrt{225}$	3). $\sqrt{\frac{36}{121}}$	4). $\sqrt{1.69}$
----------------------	----------------------	--------------------------------	----------------------

Section 11: Square Roots: Solving Equations:

Directions: Solve each equation.

1). $x^2 = 64$	2). $900 = y^2$	3). $z^2 = 0.81$
-------------------	--------------------	---------------------

Section 11: Rational Numbers: Part 1: Fractions to Decimals:

Directions: Write each fraction or mixed number as a decimal.

1). $\frac{2}{8}$	2). $-\frac{4}{5}$	3). $4\frac{9}{25}$
----------------------	-----------------------	------------------------

Section 12: Rational Numbers: Part 2: Decimals to Fractions:

Directions: Write each decimal as a fraction or mixed number in simplest form.

1). 0.75	2). 0.44	3). -5.05
4). $-6.\bar{7}$	5). $0.\bar{38}$	

Section 13: Pythagorean Theorem: Diagrams:

Directions: Determine the value for the variable in each figure. Round to the nearest tenth if necessary.

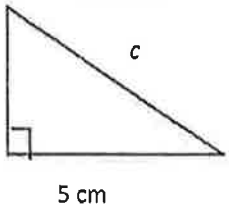
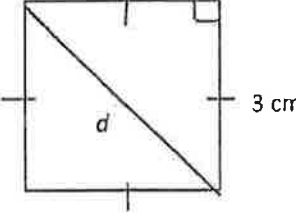
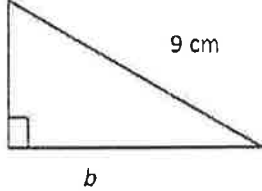
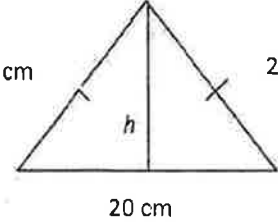
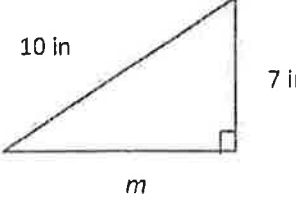
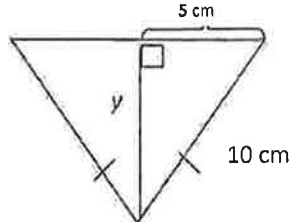
1). 	2). 	3). 
4). 	5). 	6). 

Section 14: Comparing Rational Numbers:

Directions: Write $<$, $>$, or $=$ to make a true sentence.

1). $\frac{3}{8}$ 0.375	2). -0.233 $-0.\bar{23}$
----------------------------	-----------------------------

Section 15: Ordering Rational Numbers:

Directions: Write number from least to greatest.

1). $0.\bar{3}$, 0.3, $0.3\bar{4}$, $0.\bar{34}$, 0.33	2). $-\frac{2}{3}$, $-\frac{7}{12}$, -0.66, $-\frac{5}{6}$
--------------------------------------------------------------	-----------------------------------------------------------------

Section 16: Coordinate Plane: Part 1 and 2: Identify:

Part 1: Directions: On the line before each word write the letter that represents it in the graph on the right. Letters may be used more than one and some may never be used. (each blank-1 point)

1. _____ Quadrant 3
2. _____ Quadrant 2
3. _____ Y-axis
4. _____ Origin
5. _____ Horizontal Axis
6. _____ Vertical Axis

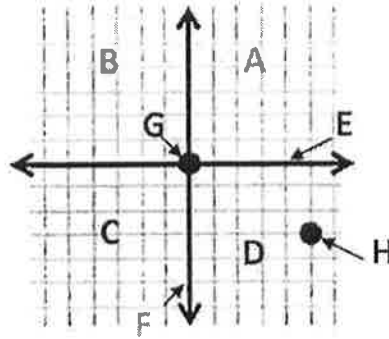

Part 2: Directions: Complete each statement by filling in the most correct word from the word bank below. (each blank-1 point)

7. The first term in an ordered pair is called the _____ coordinate.
8. The second term in an ordered pair is called the _____ coordinate.
9. All the points in Quadrant 3 are _____.
10. All the points in Quadrant 1 are _____.

Word Bank:						
Graph Paper	Abscissa	Flat	Change in x	Ordinate	Negative	y
Change in y	Vary	Cartesian Plane	Positive	Quadrants	z	x

Section 17: Plotting Points:

Directions: In Table 1 write the coordinates of each point. In Table 2 label the points on the coordinate plane by using the given coordinates.

Table 1		Table 2
A: _____ B: _____ C: _____ D: _____		E: (-5, -3) F: (-3, 7) G: (3, 2) H: (-8, 0)

Section 18: Rates:

Directions: Express each rate as a unit rate. Write the rate in a statement. Round to nearest tenth if needed.

1). 48 miles in 5 hours. _____

2). \$10.50 for 15 pounds. _____

3). 100 meters in 12.2 seconds. _____

4). 11,025 tickets sold at 9 theaters. _____

Section 19: Slope from a Graph:

Directions: Find the slope of the lines.

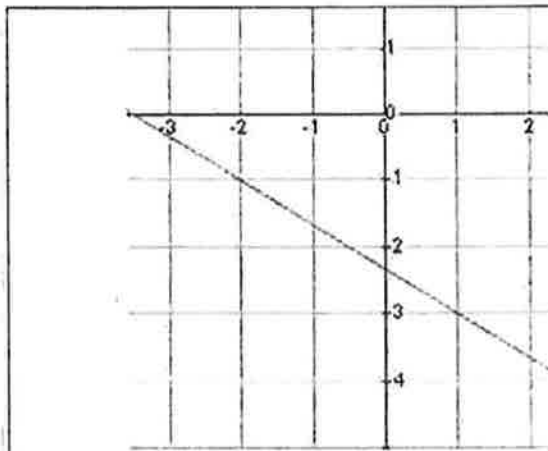

Slope: _____

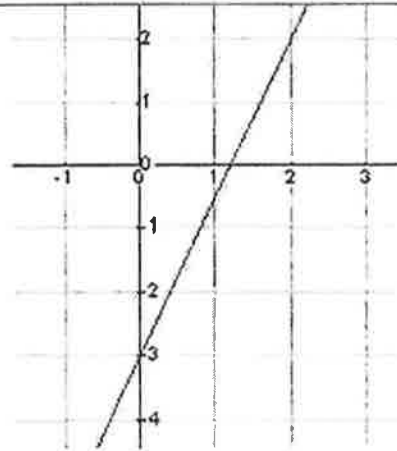

Slope: _____

Section 20: Slope from a Table:

Directions: Find the slope given by the tables.

X	Y
-5	-6
10	0
25	6

Slope: _____

X	Y
5	-1
-3	-7
-11	-13

Slope: _____

Section 21: Ratios to Percents:

Directions: Write each ratio or fraction as a percent.

1) 3 out of 5	2) $\frac{9}{20}$	3) 11:25	4) 7 out of 10
------------------	----------------------	-------------	-------------------

Section 22: Percents to Fractions:

Directions: Write each percent as a fraction in simplest form.

1) 30%	2) 32%	3) 82%	4) 45%
-----------	-----------	-----------	-----------

Section 23: Percents to Decimals:

Directions: Write each percent as a decimal.

1) 29%	2) 6.2%	3) 23.7%
-----------	------------	-------------

Section 24: Decimals to Percents: 2 pts. each.

Directions: Write each decimal as a percent.

1) 0.9	2) 6.21	3) 0.036
-----------	------------	-------------

Section 25: Scale Drawings:

Directions: Use the following given information to solve the following problems.

The scale on a set of architectural drawings for a house is 0.5 inch = 3 feet. Find the actual length of each room.

	Room	Drawing Length	Actual Length
1).	Living Room	3 inches	
2).	Kitchen	1.4 inches	
3).	Master Bedroom	$2\frac{1}{4}$ inches	

Section 26: Similar Polygons:

Directions: Find the missing values in the similar polygons.

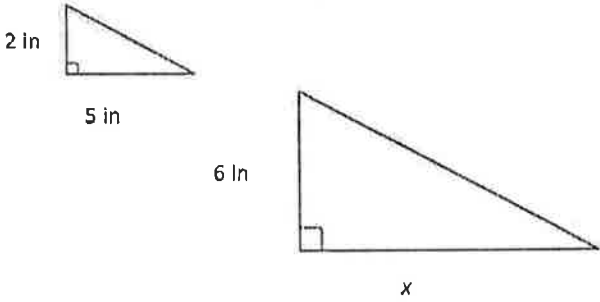
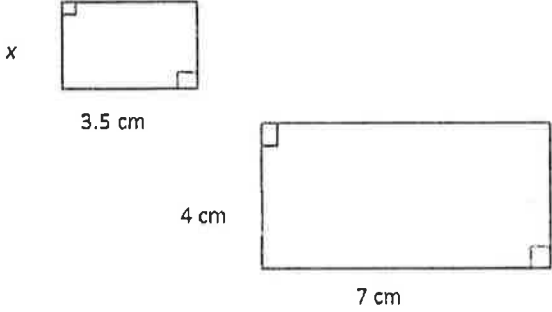
<p>1).</p> 	<p>2).</p> 
-----------------------------------------------------------------------------------------------	------------------------------------------------------------------------------------------------

Section 27: The Percent Proportion/Equation:

Directions: Solve

<p>1).</p> <p>What is 15% of 15?</p>	<p>2).</p> <p>17 is what percent of 25?</p>
<p>3).</p> <p>152 is 2% of what number?</p>	<p>4).</p> <p>What is 12% of 62.5?</p>
<p>5).</p> <p>What percent of 675 is 150?</p>	<p>6).</p> <p>What number is 130% of 52?</p>