

REQUEST FOR QUOTATION	TROY SCHOOL DISTRICT 1140 RANKIN, TROY, MICHIGAN 48083 248-823-4027 FAX: 248-823-4077	REQUISITION
No. 9749		
DUE DATE 12/17/2012 NO LATER THAN 3:00 p.m.		DATE 12/3/12

REQUEST FOR QUOTE – NOT AN ORDER

THIS FORM MUST BE UTILIZED WHEN RESPONDING TO THIS REQUEST
 BID ENVELOPE ENCLOSED

THE RFQ NUMBER MUST APPEAR ON ALL QUOTATIONS AND RELATED CORRESPONDENCE, THIS IS NOT AN ORDER

Quantity	DESCRIPTION	UNIT PRICE	AMOUNT
	<p>Please supply us with your bid to furnish the Troy School District with INSTALLATION OF ADA COMPLIANT POOL LIFTS.</p> <p style="text-align: center;"> Copies of the bid are available at: www.troy.k12.mi.us/purchasing/items_out_for_bid.htm </p> <p style="text-align: center;"> Bid recaps will be available at: troy.k12.mi.us/purchasing/index.htm </p> <p style="text-align: center;"><u>FACSIMILE BID IS NOT ACCEPTABLE</u></p> <p>Bids will not be accepted if submitted after the deadline specified (local time) in the advertisement to bid or in the information to bidders. The late submission of a bid makes the bid nonrepsonsive and is a material defect which shall not be waived by the Board of Education. Delays in the mail will not be considered. All Late bids in the mail will be returned to the bidder unopened.</p> <p>Proposal for the submission of alternatives by vendors will be accepted and reviewed. However, if any substitution or departure is not clearly noted and described, it will be understood that the bid intends to exactly meet the specifications.</p> <p>The Board of Education shall be the sole judge as to whether the proposed goods are "equal" or "approved". Quotations must be mailed or delivered to the Purchasing Office, 1140 Rankin, Troy, MI 48083 no later than 3:00 p.m. on the date shown above. Michigan State Sales and Use Taxes and Federal Excise Taxes do not apply unless otherwise indicated. Exemption certificates will be furnished when necessary. This request imposes no obligations on the buyer. The Board of Education reserves the right to accept or reject any or all bids or to split awards by items or to accept bids, which will best serve the Board of Education.</p>		

THIS AREA MUST BE FILLED IN

DELIVERY TIME	PRICES FIRM FOR	NAME OF COMPANY	TELEPHONE NO.
TERMS		NO. & STREET	FAX #
FOB DELIVERED	ALL DELIVERY CHARGES MUST BE INCLUDED IN PRICES SHOWN	CITY, STATE & ZIP CODE	E-MAIL
CONTACT PERSON (PLEASE PRINT)		SIGNATURE	DATE

AFFIDAVIT OF BIDDER

The undersigned, the owner or authorized officer of _____
(the "Bidder), pursuant to the familial disclosure requirement provided in the _____
_____ (the "School District") advertisement for construction bids, hereby represent and warrant
except as provided below, that no familial relationships exist between the owner(s) or any
employee of _____ and any member of the Board of Education of
the School District or the Superintendent of the School District.

List any Familial Relationships:

BIDDER:

By: _____

Its: _____

STATE OF MICHIGAN)
)ss.
COUNTY OF _____)

This instrument was acknowledged before me on the _____ day of _____, 2012,
by _____.

, Notary Public

_____ County, Michigan

My Commission Expires: _____

Acting in the County of: _____

TROY SCHOOL DISTRICT
Installation of ADA Compliant Pool Lifts
Bid #9749

Specifications

Part 1 – General

1.01 WORK SCOPE

- A. Provide new pool lifts and install in complaints with all ADA Pool Lift Laws.

1.02 SCHEDULING

- A. The completion date for the project is **31 January 2013**.

Part 2 – Service

2.01 SERVICE SCOPE

- A. Install new ADA Compliant Pool Lifts at the following locations:
 - Athens High School
4333 John R Road
Troy, Michigan 48085

 - Troy High School
4777 Northfield Parkway
Troy, Michigan 48098
- B. Provide a detail list of the materials that will be required to complete this project.
- C. Repair any and all areas damaged during the installation of the lifts. Make sure to take every precaution to ensure that no humans or surrounding environment is harmed. Any damage to structures, floors, wall, etc will be repaired with like materials at the contractor's expense.
- D. All debris must be removed and the area cleaned up at the end of each work day.

2.02 MATERIALS

- A. See attached document for the Pro Pool-XR Pool Lift. **Note:** The District will except alternate pool lifts systems if they are equal to the specifications provided and are 100% in compliant with ADA laws and regulations.

Part 3 – Execution

3.01 INSPECTION

- A. All work will be performed to the satisfaction of the Executive Director – Kenneth D. Miller or his representative. If during any and/or all inspections the work is found to be unsatisfactory, the discrepancy noted will be corrected at the contractor's sole expense and at no cost to the Troy School District within 10 days from the date of notice. The decision of the Executive Director or his representative will be final.
- B. Once the project is completed the company rep will be required to walk the project with the Executive Director for final approval.

3.02 SAFETY GUIDELINES

- A. During normal school hours all workers will be require to check in with the main office before entering school district property.
- B. Must maintain a safety zone around areas being serviced at all times.
- C. You will be required to check with the Executive Director prior to the start of this project for approval to store or create a staging area for equipment, gang-boxes, trailers and materials.
- D. The contractor will be solely responsible and abide by all federal, state, and local laws pertaining to the safety of all employees and observers and will maintain workers compensation as required.

3.03 QUALITY ASSURANCE

- A. Work areas must be kept safe, clean and organized at all times.
- B. Contractor will be responsible for any and all damage caused during the removal, installation and/or staging process.
- C. Hours of work will require prior approval from the Executive Director and are based on the City of Troy local code guidelines. The contractor will also be required to adjust their work schedule so it does not interfere with school activities or events.
- D.

NAME OF BIDDER: _____

ADDRESS: _____

TELEPHONE: _____

SIGNATURE: _____

THE PRO POOL™-XR POOL LIFT

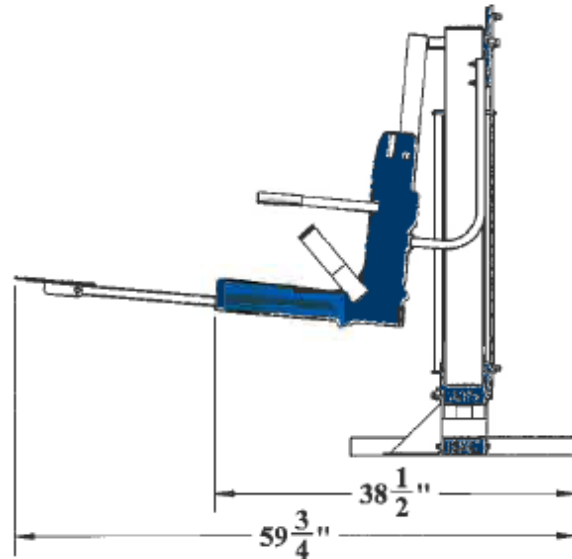
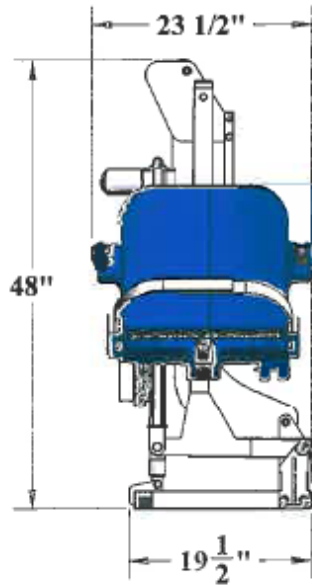
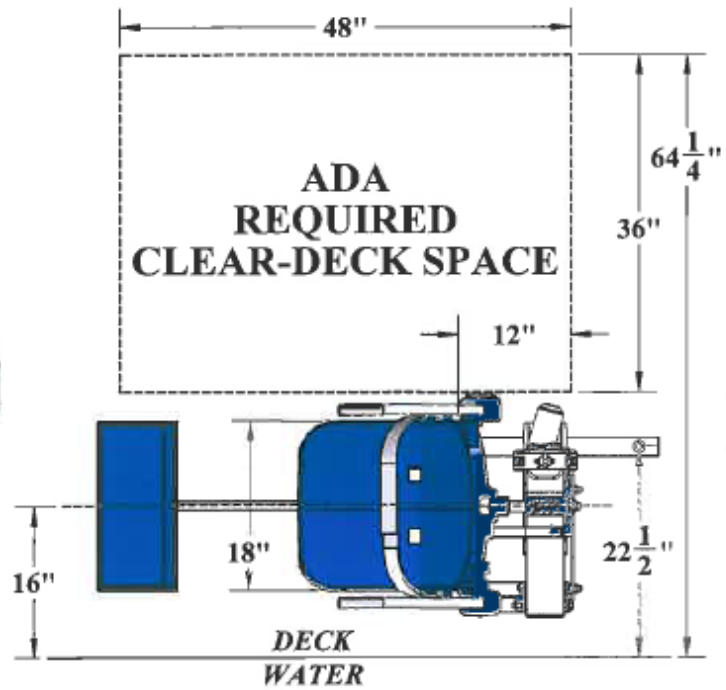
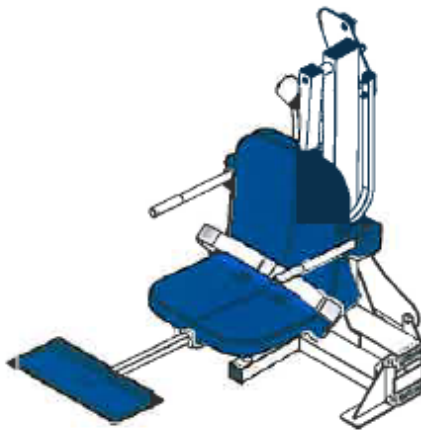

Aqua Creek Products
The Total Solution for Pool and Spa Access

9889 GARRYMORE LANE
MISSOULA, MT 59808
(406) 549-0769
FAX (406) 549-2602

NOT TO SCALE
*DIMENSIONS ARE SUBJECT TO MANUFACTURING TOLERANCES

PRODUCT:	F-004PLB-XR	
DWG. NO.:	F-004PLB-XR-1	
SCALE:	1:18	DATE: 10/1/12
DRAWN BY:	DS	REVISION: A

THE PRO POOL™-XR POOL LIFT

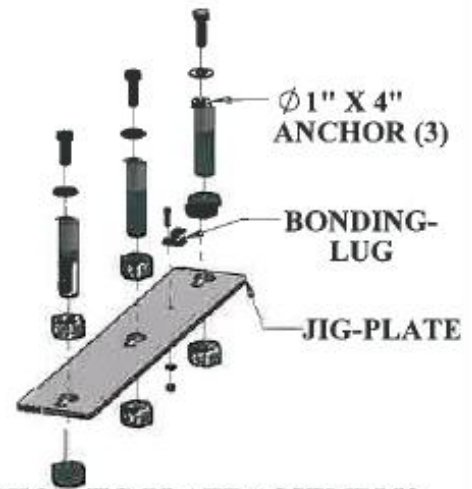
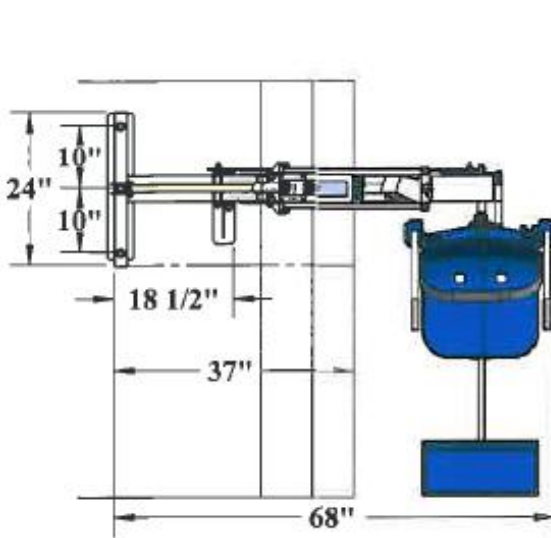

ANCHOR JIG-PLATE ASSEMBLY
(PART NUMBER: F-910SAJP)

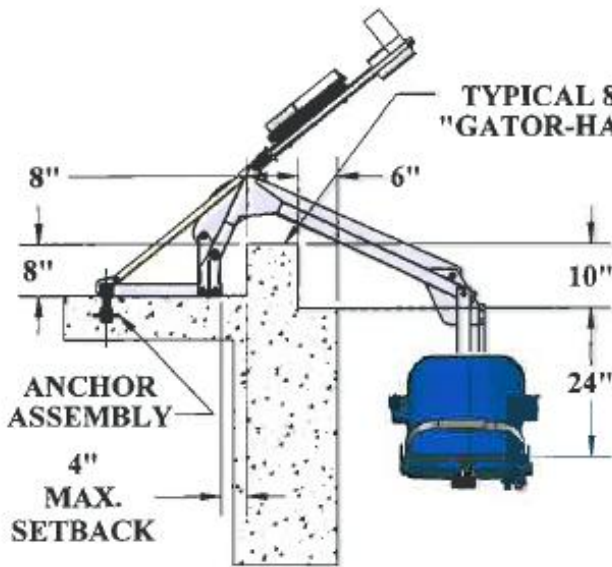

PRO POOL-XR ON "HAUNCH"

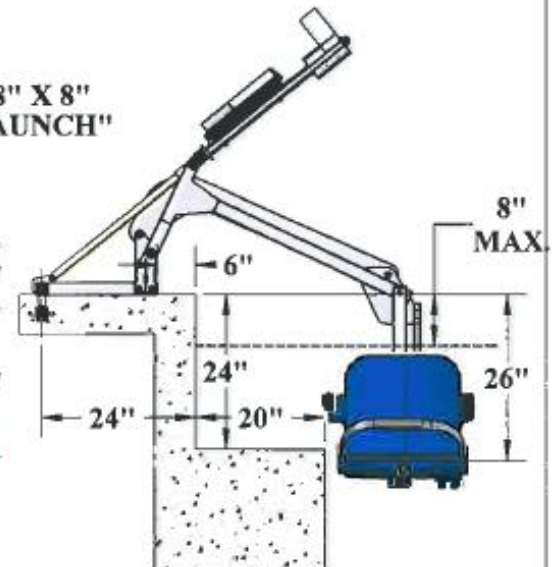

PRO POOL-XR ON SPA BENCH

Aqua Creek Products
The Total Solution for Pool and Spa Access

9889 GARRYMORE LANE
MISSOULA, MT 59808
(406) 549-0769
FAX (406) 549-2602

NOTES:
SPECIFICATIONS ARE SUBJECT TO CHANGE WITHOUT NOTICE

PRODUCT:	F-004PLB-XR	
ENC#:	F-004PLB-XR-2	
SCALE:	1:18	DATE: 10/1/12
DRAWN BY:	DS	REVISION: A

THE PRO POOL™-XR POOL LIFT

SPECIFICATIONS:

LIFTING CAPACITY: 350 lbs [159 kg]
STATIC LOAD CAPACITY: 525 lbs [238 kg]

MAX. DRAFT (DECK TO WATER): 8.0" [203mm]
MAX. SETBACK (ANCHOR ϕ TO WATER): 38" [965mm]

OVERALL HEIGHT (MAX): 48" [1219mm]
MAX. WIDTH (DEPLOYED): 59-3/4" [1517.7mm]
MAX. LENGTH (DEPLOYED): 68" [1727mm]
STOWED LENGTH (MAX): 23-1/2" [597mm]
STOWED WIDTH (NO LEGREST): 38-1/2" [978mm]

WEIGHT: 145lbs [65.8kg]

MATERIALS:

LIFT FRAME: TYPE 304 STAINLESS STEEL
BASEPLATE: TYPE 304 STAINLESS STEEL
CHAIR & FOOTREST: LLDPE POLYETHYLENE
SAFETY BELT: HEAVY-DUTY POLYESTER STRAP, HOOK & LOOP FASTENER
POWDER COATING: OFF-WHITE EPOXY

STANDARD EQUIPMENT:

DUAL FLIP-UP ARMRESTS
FLIP-DOWN LEGREST
SAFETY BELT
24VDC BATTERY & CHARGER
WATERPROOF HANDSET-REMOTE
3-PT ANCHOR KIT

AVAILABLE OPTIONS:

PRO POOL-XR LIFT NO ANCHOR (PN: F-004PLB-XRNA)
ANCHOR JIG ASSEMBLY (PN: F-910SAJP)
HEADREST ASSEMBLY (PN: F-422PLH)
PULLOUT LEGREST (PN: F-105LAR)
COVER, POLYESTER (PN: F-422PPC)



9889 GARRYMORE LANE
MISSOULA, MT 59808
(406) 549-0769
FAX (406) 549-2602

NOTE:
*SELECTIVE USE ONLY SUBJECT TO OWNERS RETENTION RIGHTS

PRODUCT:	F-004PLB-XR	
DWG#:	F-004PLB-XR-3	
SCALE:	NA	DATE: 10/1/12
DRAWN BY:	DS	REVISION: A